



---

ROYAL BOTANIC GARDENS,  
KEW.  
GARDEN LIBRARY.

---



0062633

ROYAL BOTANIC GARDENS  
KEW



1.2/121



Digitized by the Internet Archive  
in 2018 with funding from  
BHL-SIL-FEDLINK

<https://archive.org/details/journalofhorticu3151hogg>













THE

# JOURNAL OF HORTICULTURE,

## COTTAGE GARDENER,

AND

## HOME FARMER.

A CHRONICLE OF COUNTRY PURSUITS AND COUNTRY LIFE, INCLUDING BEE-KEEPING.

CONDUCTED BY

ROBERT HOGG, LL.D., F.L.S.

Established



in 1848.

VOLUME XV. THIRD SERIES.

JULY—DECEMBER, 1887.

LONDON

PUBLISHED FOR THE PROPRIETOR, 171, FLEET STREET.

LONDON:  
PRINTED AT THE JOURNAL OF HORTICULTURE OFFICE,  
171, FLEET STREET.

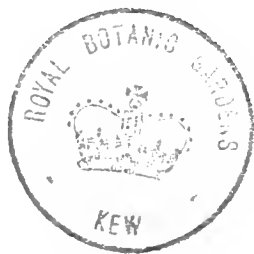

## TO OUR READERS.

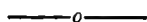

THE contents of the Index for binding with the half-yearly volume closing with the end of the year 1887 will show the varied nature of the subjects treated therein. We trust the several articles were serviceable and interesting as they appeared, and that in the collected form they will fairly represent the horticulture of the period. We may also hope that the volume will not be unworthy of the long series preceding, the whole forming an encyclopædia of practical and ornamental gardening creditable to the many pens and many minds that have shared in its production.

Looking over the pages of the PAST, sad and pleasant memories are intertwined. Our fellow helpers who have gone before we cannot forget, and we shall always find it hard to part with old associates; but the loss is tempered by the thought and the knowledge that they strove, and not unsuccessfully, to do their duty and leave the world better than they found it.

For the PRESENT we have to express our thankfulness and satisfaction in that we have still with us so many friends whose efforts do not flag, and whose enlarged experience enables them to teach sound doctrine. To the old and the young these remarks apply, for both gather wisdom yearly by study and by practice.

To the FUTURE we look forward with confidence. We have the same co-helpers who will not fail, so long as health is given them, to disseminate the knowledge they have acquired, and which is sought for by others in increasing numbers. We have also young men of promise pressing steadily on—men who are acquiring knowledge by their commendable efforts to impart it; and we have earnest inquirers who, in seeking instruction, stimulate to research.

Our greetings, therefore, are conveyed to old and young writers, readers, and inquirers—indeed to all who aid in the realisation of the desire for pleasant and fruitful gardens, and a long period of horticultural prosperity.

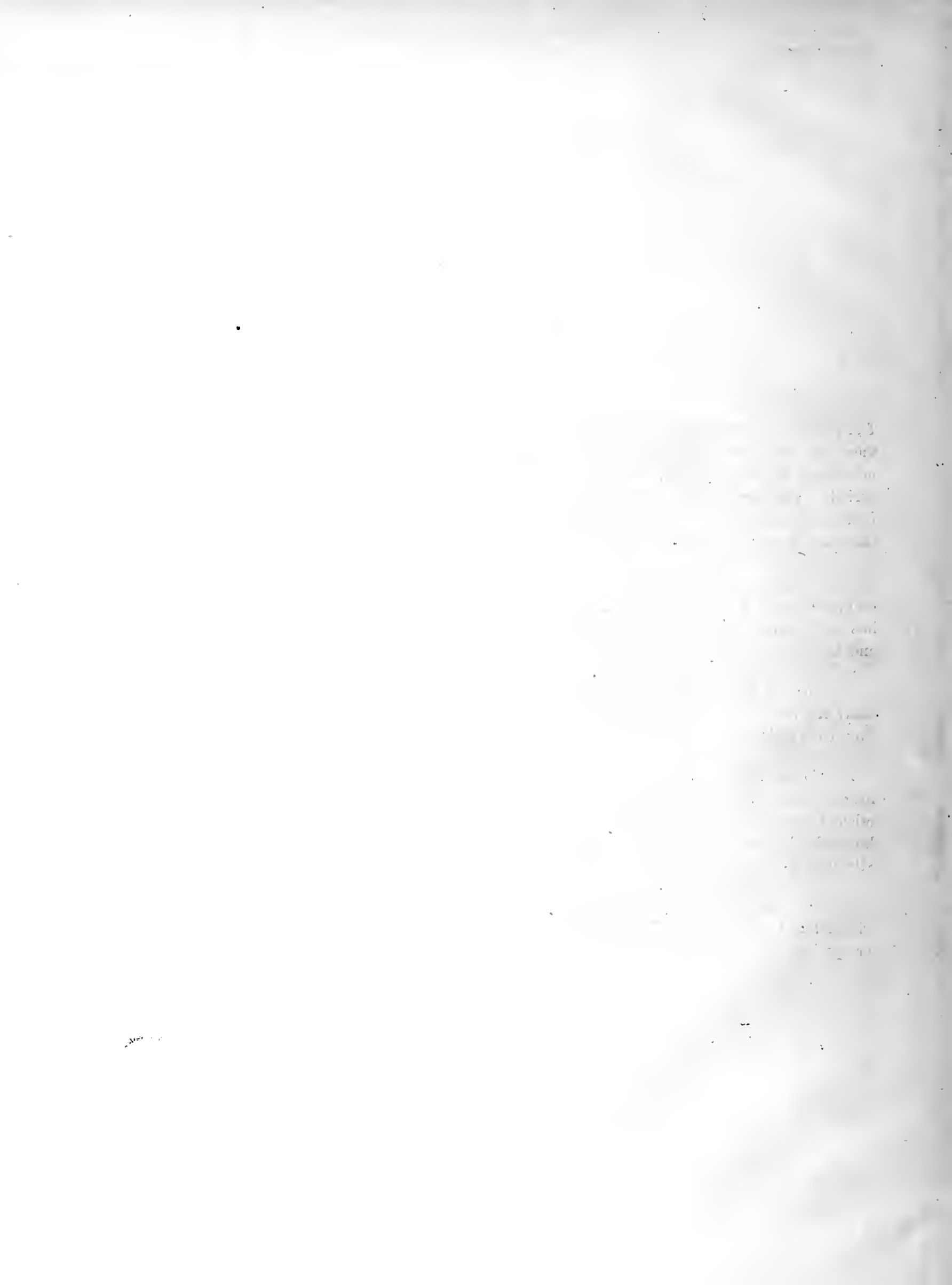



INDEX.

**ABBERLEY HALL**, 318  
**Aberaman House**, 322  
**Acalypha tricolor** for decorative purposes, 340  
**Achmenes**, 282  
**Adiantums**, 111; *cuneatum* and *Pacotti*, 126; *dolabriforme*, 225; *Legrandi*, 235; *reginae*, 518; *cuneatum*, 525  
**Agathaea coelestis**, 516  
**Agriculture**, tropical, 272  
**Alantus glandulosa**, 292  
**Allamandas**, 216, 549; *A. Hendersoni* (*Wardleana*), 341  
**Alwicks Castle**, 295  
**Amaryllises**, 303; culture of, 193; at rest, 360; *reticulata*, 468  
**Amateur**, what's an? 478  
**Amateur's viney** in autumn, 244  
**Amberboa moschata**, 516  
**American plants**, 124  
**Anderston's**, a dinner at, 533, 566  
**Anemone Pannini**, 337  
**Annals of Botany**, 116  
**Annuals** for spring flowering, 101  
**Anthrium Veitchi**, 560  
**Antirrhinums**, spotted, 360  
**Antwerp**, shows at in 1888, 469  
**Apples—spurs**, thinning, 42; crop in Canada, 91; *Cooling's Beauty*, 120; tree leaves spotted, 128; cold storage of, 139; in Yorkshire, 163; leaves blotched, 218; *Comt Pendu Plat*, 227; late, 281; for orchard, 284; selections of for Great Britain, 271; and Pears, stocks for, 369; *Bismarck* and *Gascogne's Seedling*, 325; *Pear grafted* on, 320; *Bramley's Seedling*, 416; *Nottinghamshire*, 444; *Nutmeg Pippin*, 482; and *Plums* for market, 482; *Potts' Seedling*, 505; notes on the, 541  
**Apple trees**, scale on, 438; enemies, 493  
**Apple and Pear Congress** at Edinburg, 271  
**Arbicultural (English) Society**, 156  
**Armstrong Park**, 186  
**Artichokes**, Glohe, 215  
**Ashton Court**, notes from, 468  
**Ashburne House**, Sunderland, 275  
**Asparagus** culture, 92, 268, 271, 291; varieties, raising plants, 154; transplanting, and manures for, 191; thinning seedling, 219; notes on culture, 223; beds, salting, 328; the cultivation of the, 312; beds, 372; forcing, 435, 548; *plumosus*, 525; manuring, 64  
**Aspleniums**, 110  
**Attlee**, death of Mrs., 494  
**Auriculas**, descriptions of, 70; descriptions of, green-edged, 91; grey-edged, descriptions of, 123; descriptions of, 142; descriptions of selfs, 209; *Page's Champion*, 540, 561  
**Auricula (National) and Primula Society**, suggestions, 356  
**Auriculas (Scottish) Society's Meeting**, 494  
**Autumn work**, 553  
**Avondale**, Bath, 278  
**Azaleas**, 18, 303; dividing, 284; hardy, 392, 425

**ADMITTON, NOTES FROM**, 383  
**Ballast-burning**, 356  
**Barnsley**, Annual Meeting of the Yorkshire Association of Horticultural Societies at, 112  
**Bath**, jottings from, 276  
**Bath Show**, 234

**Beans**, Kidney, 391, 215; preserving, 42  
**Beaulieu**, Mr. Gray's garden at, 183  
**Bedding plants—**for spring, 18; propagating, 149  
**Bedford (Chrysanthemum Society)**, 335  
**Bedford Show**, 57  
**Bees—practical bee-keeping**, 19, 79, 149, 194, 233, 282, 376, 370, 415, 458, 526, 572; apian notes, single case hives—bee-keeping queries, 41; notes on swarming, foundation, wintering, sections, 64; notes on the weather, the heather, disease of bees, honey fairs, 102; notes on, 126, 261; Hants and Isle of Wight Bee-keepers' Show, 103; Cyprian and Carniolian bees, 103; a heavy honey yield, 103; crowding bees in winter, 126; the best hive in creation, standard hives, foreign bees, Syrian bees, 127; gathering honey from Wheat, 127; Cyprian and other foreign varieties, 172; at the moors, meal, visiting flowers, 195; hints to beginners, 216, 347, 550; hives, 216; robber bees, drone, 217; North of Scotland Apian Society, 217; May sickness, 249; swarming, queens de-throned, 281; in a box, weather and honey, heather season, preparations for winter, suspending sections, 394; tenner of bees, Cyprians, 305; preparing for next summer, 347; large swarms, 347; swarming v. non-swarming, 349; comb foundation, 348; the past honey season, 348; odorless foul brood, 371; term of a bee's life, number of eggs laid by a queen, 349; honey strainer, the weather, Syrian bees, 393; the distance bees fly, 393; *Bacchus minor*, 416; in and in breeding, 437; drones in November, 437; distance of flying, 459; curing foul brood, 480; fertile workers, odorless foul brood, 431; wearing out at the heather, 593; distance of flying, re-swallowing honey, gathering honey, 504; odorless foul brood, 527; placing bees at the heather, 527; wintering bees, 550; queen rearing stand and feeder, 551; distance from heather, 573  
**Beetroot**, storing, 345  
**Bezonias—**tuberous, 3, 28, 101, 216 495; at Forest Hill, 3, 223; new, 32; unhealthy, 42; *Claribel* and *Rosa compala*, 53; *Edelweiss*, Major Lendy, Shirley Herbert, 76; at Yeovil, 272; 345; John Heal, 360; Adonis, 402, 408  
**Belgian horticulturists**, meeting of, 31, 250, 539  
**Bella Donna Lilies**, 273  
**Benefit and Provident Society**, United Horticultural, 323  
**Beta maritima**, a substitute for Spinach, 333  
**Bilston**, new park at, 8  
**Birmingham**, lectures on gardening at, 336  
**Blackberries**, American, 305  
**Black Hamburgh Grapes**, late, 239  
**Blits** in gardens, 177  
**Boeonia cordata**, 227  
**Bolophyllum barbigera**, 6  
**Bones**, dissolving, 42  
**Bone flour**, steamed, 552  
**Book**, review of: Mr. A. F. Barron's *Vine and Vine culture*, 342  
**Borecole**, Jellico's Hearting, 494

**Botanic (Royal) Society's Evening Fête**, 26; dates of shows in 1888, 517  
**Bougainvillea glabra**, 216, 549; *splendens*, 241  
**Bouquets**, exhibiting and judging, 468, 483, 545, 445, 563  
**Bouvardias**, 230; President Cleveland, 350, 367; at Roehampton, 425; the culture of, 538, 553, 572  
**Briars** from seed and cuttings, 350  
**Brighton and Sussex Floricultural Society**, 116  
**Brighton Show**, 233  
**Broccoli**, 548  
**Bulbs** how to grow, 9; the Dutch trade in, 54; notes on, 69; replanting, 160; peeling and storing, 241; beds, 333  
**Bullfinches** and fruit trees, 424  
**Burton-in-Lonsdale Floral and Horticultural Society**, 204  
**CABBAGE AND CELERY SHOW**, 251  
**Cabbages**, autumn-sown, 125, 259; blindness in, 218  
**Calanthes**, 39, 178, 456; at Ewell, 223; *Halli*, 408; in baskets, 493; at Raby, 516; *sanguinaria*, 518  
**Calceolarias**, raising, 65; 303, 359, 572  
**Calcedonian (Royal) Society's Show**, 59  
**Callas**, 259; leaves spotted, 262  
**Camellias**, 18, 303; in mid-winter, 536; notes on the, 531  
**Canker** in fruit trees, 424  
**Cannas**, new, 162; 525  
**Canwick Hall**, Orchids at, 331  
**Cape Gooseberry** culture, 196  
**Cardiff and its gardens**, 579  
**Cardiff Castle**, 494  
**Carnation and Picotee Shows**, 71, 121  
**Carnations—***Alice Ayres*, 76; tree, 101; layering, 101; Mrs. Reynolds Hole, 139; *Souvenir de la Malmaison*, 162; 303; *Pride of Penshurst*, 447, 470, 434; *Paul Engleheart*, 470; Mrs. C. Hawtreay, 434 447; for winter, 529; 518  
**Carpet** bed, a Jubilee, 248  
**Carler's Provident Sick Fund**, 425  
**Castle Coch**, 405; Vineyard, 427  
**Catasetum Bungeorhi**, 120  
**Caterpillars**, destructive, 350  
**Cattleya Gaskelliana**, 89; *Ameisiana*, 134; 436; *Lawrenciana rosea superba*, 418; and *Laelias*, 472; *sororia*, 516; *eltrina*, culture of, 564  
**Cauliflower Dean's Snowball**, 8, 31; 70, 259; *Veitch's Autumn Giant*, 345  
**Cedar of Lebanon**, 251  
**Celery**, earthing, 302; at Kalmagoo, 361  
**Celery Show** at Kendal, 293  
**Celosias**, 18, 346  
**Cereus grandiflorus**, 91  
**Chatsworth**, notes from, 467  
**Cheadle Show**, 153  
**Chelidonium odora**, 174  
**Chelsea**, a day at, 564  
**Chemistry of vegetation**, 293  
**Cherries—Morelo**, 21; *Reine Hortense*, 103; *Emperor Francis*, 120; under glass, 303; leaves blistered, 372  
**Cherry House**, 101, 525; work in, 479  
**Chertsey Show**, 33  
**Che-lnuts**, Gunnersbury, 470  
**Chinchonas**, introduction of to the Nigiris, 339  
**Chionodoxa Lucifera**, 416

**Chiswick**, a critique of trials at, 45; vegetable trials at, 161  
**Chiswick Show**, 58  
**Chiswick Gardeners' Mutual Improvement Association**, 470, 551  
**Carnation and Picotee Society (National)**, Northern Section, Christmas in Canada, 561; Christmas Roses (*Helebores*) 559  
**Church decorating**, 535  
**Chrysanthemums—***Madame Desgranges*, 31, 294; 41; dwarf, 123; eaten, 128; bug, 159; growers at Swanley, 164; notes, 238; prospects of the season in the north, 249; topping plants, early bloom, challenge plate at Hull, 311; *L'Africaine*, J. W. Cobbett, 325; insets on, 328; at the Inner Temple, 333; *Fashiony Park*, 333; list of shows, 333; protection for, 314; shows, certificating, at Camberwell and Putney, 332; *Edouard Audinier*, 361; at Morden Park, the Hull challenge cup, 334; Mrs. J. Wright and Mary Ouvray certificated, 337; leaf miner, 572; Mr. Gunnar, 331; Mrs. J. Wright, 334; size of stand for, 394; notes—Mr. Mease and the Hull Challenge Cup, 387; new varieties, 387; at Chelsea, 337; at Roehampton, Warren House, Finsbury Park, and Hackney, 338; Mr. A. Suber's varieties, 338; northern shows, 359; measuring blooms, 389; notes, at Swanley, 339; Forest Hill, Chilwell, 449; northern and southern growers, 491; the Hull Vase controversy, 491, 423; early varieties, saving seed, 415; measuring, 443; stands for, 351; a review of the past season, 464; challenge cups, 471; sports, Mrs. Norman Davis, Charles Gibson, 471; an old in France, judging, 471; the science of judging, 485; in America, 491; at Woodcote, Downham and Walton Lea, equal prizes, Mrs. N. Davis, Amy Furze, Hull cup, 499; new, 505; 511; beds, Edinburg, Paris, and Perry Hill, 509; judging by ballot, 509; *Hans Niemand*, 517; *Lord Eversley*, 518; leaf-mining insect (*Trypeta artemisiae*), 528; shows, Hull, 523; house at Chilwell, 519; judging, 524; class, a representative, 522; class cards, 522; challenge vases, 522, 524; *Eccles* and *Ainwick* shows, 523; Amy Furze, 523; at Ashton Hall, 523; new, 541; Amy Furze challenge vases, 549; a representative Chrysanthemum class, 547; rival shows, 547; useful varieties, 567; judging, early varieties, new varieties, 568; Amy Furze, 568  
**Chrysanthemum Shows—***Coro Exchange* London, Southampton, 339; *Crystal Palace*, 498; Havant, Kingston, 469; Highgate, 419; Exeter, Brighton, 411; National Chrysanthemum Society, 412; *Croydon*, 419; *Huddersfield*, 426; *Portsmouth*, 423; *Brixton*, *Lewisham*, 430; *Bath*, 431; *Weston-super-Mare*, 432; *Ascot*, 434; *Stret*, *Newport*, *Walton*, 433; *Putney*, *Twickenham*, *Sheffield*, 434; *Leamwich*, 435; *Falmouth*, *Devizes*, 448; *Walls*, *Chomel*, *Walford*, 448; *Winchester*, *Cuckfield*, 450; *Lincen*, 451; *Braunton*, 452; *Rye*, *Rugby*, *York*,

**CHRYSANTHEMUM SHOWS—***continued—*  
**Chiswick**, Colchester, 453; *Wimbledon*, *Barnsley*, *Salisbury*, 454; *Hull*, 455; *Reading*, *Wokingham*, *Sheffield*, 456; *Bolton*, 471; *Faversham*, 472; *St. Albans*, 473; *Buckingham*, *Beverley*, *Bristol*, 474; *Bedford*, 475; *Fareham*, *Chichester*, and *Pontefract*, 476; *Wellington* and *Liverpool*, 477  
**Chrysanthemum Society (National)**, 235, 368, 469; *Floral Committee*, 521, 447, 495, 336; *General Committee Meeting*, 381; annual dinner, 522  
**Cigars**, home-made, 1-5  
**Cinerarias**, leaves disfigured, 20; 339  
**Cladosporium fulvum** on Tomatoes, 429  
**Clerodendron Balfourianum**, 216, 549  
**Clovenfords**, the Grapes at, 223  
**Cologyna corrugata**, 173; *crisata*, 437  
**Coffee leaf disease**, 88  
**Cottagers and amateurs exhibiting**, 574  
**Crazeus**, Rothbury, 251  
**Crimsons**, notes on, 397, 496, 407  
**Crotoms**, propagating, 143  
**Croydon Flower Show**, 9  
**Crystal Palace Fruit and Dahlia Show**, 210; judging at, 295, 221, 228, 251, 277; *Fruit Show*, 317  
**Cucumbers** in July, 18; notes on, 28; plans, clubbing at the roots, 42; in a cold frame, 218; in America, 272; 282; late fruiting plants, 323; in winter, 438, 549  
**Cultivation**, deep versus shallow, 199; deep, 339  
**Cycas** fruits, 123  
**Cyclamens**, 18, 346; insects on, 32  
**Cypripis alternifolius**, 471  
**Cypripedium insignis**, 39; *orphanum*, 120, 134; *presans*, 179; *Harrisianum superbum*, 323; 515

**DAFFODILS FOR POTS**, 159; 257  
**Dahlia**, *Cretas* and decorative, 241; certificated, 278  
**Dahlia Show (National)**, 211  
**Dahlia**, analyses of at the National Show, 313  
**Dansons**, the *Fairleigh*, 238  
**Davalias**, 110; *tennifolia Veitchiana*, 111  
**Delphiniums**, 109  
**Dendrobiums**, 437, 532; *Stratotes*, 238; *formosum gigantum*, 517; *noBILE*, 517  
**Deudrochium filiforme**, 223  
**Deutzias**, 332  
**Digging and trenching**, 501; notes on, 333  
**Dipladenias**, 249  
**Disa grandiflora**, 159  
**Dracenas**, 10  
**Dravton Manor Gardens**, 357  
**Drought**, the recent, 83; at *Cardiff*, 116; and its lessons; 131; and its effects, 300, 334  
**Deep v. shallow working**, 311  
**Dry weather**, notes for, 1  
**Dunmore Show**, 165

**EAGLE HOUSE, DOWNHAM**  
**Grapes** at, 467  
**Ealing Show**, 33  
**Earwigs** and fruit, 191  
**Eastcliffe House**, Orchids at, 333



PLANTS CERTIFICATED—continued—

Mrs. D. Saunders, Bridesmaid, 495  
*Primula sinensis* Bridesmaid, 518; Emperor, 448; *Pteris claphamensis*, 518.—*Rhododendron Thetis*, 236. Rose Paul's single White Perpetual, 121.—*Saccolabum Heathi*, 120. *Streptocarpus Kewensis*, Watsoni, 76.—*Viola Lucy Ashton*, 120  
*Pleurothallis lamprophylla*, 541  
*Plumbago capensis alba*, 413  
 Pinns—Green Gage, 21; useful varieties of, 249; *Mirabelle Petite*, 284, 292, 350; under glass, 288; house for, 479; origin of Greengage, 505; pruning, 524; tree gumming, 552  
*Polemonium flavum*, 494  
*Polygonum Brunonis*, 252  
*Polystichum proliferum*, 148  
 Pomegranate, double-flowered, 162  
 Pope's Villa, 118  
 Poplar leaves, insects on, 305  
 Poppies, 10  
 Portmadoe Show, 162  
 Potatoes—Lemon Kidney, 42; in Yorkshire, 163; trials, 201; digging, 215; King of the Russets, 320; late, 345; spher-bering, 509; at Wakefield, 516; statistics, 539  
 Poulett Lodge, Twickenham, 118  
 Power, Mr. F., 516  
*Primulas*—Reidi, 52, 321; ob-coica, seeding and growing, 184; *sinensis* out of doors, 273; *Sapphirina*, 321; *erosa*, 425; *sinensis* Bridesmaid, 518; the history and progress of *P. sinensis*, 568  
 Primula Conference, report of the, 203  
 Privet, golden-edged, 463  
 Prizes, winning and losing, 419  
 Propagating, late, 216  
*Pterises*, 111; *serrulata*, 126; *claphamensis*, 518  
*Pyrethrums*, 109

QUALITY, QUANTITY, DEPRES-sion, 487

RABY CASTLE, 166  
 Railway rates and producers, 91  
 Ramsbottom Floral Society, 116  
 Rain in London, 138  
*Ranunculuses*, culture of, 482  
 Raspberries—and dry weather, 28; Lord Beaconsfield, 116; in autumn, 336

Reading, notes at, 255; show at, 188  
 Red spider and mildew, remedy against, 91; destroying, 174  
 Review of book—Veitch's Or-chidaceous Plants, part 2, 473  
*Rhododendrons*, greenhouse, 564  
 Richmond Horticultural So-ciety, annual meeting of, 549  
 Rockwork, making, 5.6  
*Rogeras*, 269  
 Roots for winter, 391  
 Roots, excrescences on, 505  
 Rosemary, 574  
 Rose gardea, Dr. Budd's, 277  
 Roses—in summer, 3; growing for beginners, 7; watering, 29; 42; enfeebled, 42; sports, insects, 56; at Edinburgh, Scottish growers, 67; Earl of Dunferlin and Sir Rowland Hill, 68; aot opening, 81; sporting, 80; *Maréchal Niel*, house for, 194; in pots, culture of, 114; *Maréchal Niel*, 129; best for forcing, 151; Duchess of Albany, 227; mildew on, 228; at the National Rose So-ciety's Metropolitan Show, 18-7, 245; *Roses Gloire de Dijon*, Tea-scented, 273; *Gloire de Dijon*, 293; season of 1887, 331; heps, 359; mildew on, 337, 376; in pots, 359; plant-ing, 360; on a wall, 394; *Rose Maréchal Niel*, 438; at Alder-minster Lodge, 421; Review, 441; pruning when planted, 523; garden, selections of, 549; "Roses for Amateurs," 494; for tree and arches, 505; for ex-hibition, 505  
 Rose Shows—National Rose Society's Metropolitan Show, 12; Canterbury, 14; East Gloucestershire, Eltham, 15; Twickenham, 16; Crystal Pa-lace, 34; Bath, 35; Ports-mouth, Reigate, 36; Farning-ham, Maidstone, Sutton, 37; Edinburgh (the National), 47; Oxford, 49; Hitchin, 50; Birmingham, 50; Hereford, 51; Brockham, 51; Alexan-dra Palace, 53; Carlton, 72; Christleton and Wirral, 73; Leek and New Brighton, 74; in Dublin, proposed, 515  
 Rose Society (National) Annual Meeting of, 520  
 Rothschild, Baron Nathaniel and his gardener, 227  
*Rubus rosafolius*, 560  
 Rux ey Lodge Gardens, 143

SACCHAROMETER, 373  
 St. Neots (Hunts) Show, 98  
 Salisbury show, 188  
 Salting walks, 81  
 Samphire, 305  
*Saxifraga oppositifolia*, 262  
*Schubertia grandiflora*, 236, 497  
 Scottish Arboricultural Society excursion to Balmoral, 116

*Scutellaria Mocciniana*, 293  
 Seakale, 435  
 Season and crops in East Lothian, 184  
 Seedlings, ralslag, 528  
 Seeds from Sikkim, 204  
 Seed staads at Islington, 57  
 Seed trade, English, and Sun-day labour, 8  
 Shading and air glving, 46, 29  
 Sheffield and West Riding Chrysanthemum Society, 115, 539  
 Showing and judging, 221, 232  
 Shrewsbury show, 167  
 Slugs in the Orchid house, 479  
 Smoke injuring p ants, damages for, 139  
 Snow in London, 320; on plants, 574  
*Sobralia macrantha*, culture of, 179  
 Soil—improving, 81, 333; Mr. Gilmour's lecture on, 426, 444  
*Solanums*, 269; *corniculatum*, 429  
*Sophracotylea Batemanniana*, 472  
 Southampton Show, 93  
 Southampton, 258  
 South Shields Parks, 274  
 Spinaeh for dry weather, 333  
 Stable manure, 294, 421  
*Statice Suworowi*, 337  
*Staphanotis floribunda*, 216, 549  
*Streptocarpus Watsoni* and *Kewensis*, 76  
*Styrax japonica*, 29  
 Strawberries—Palatine, 8; Lox-ford Halt Seeding, 27; *Fère* at Chiswick, 31; at Bath, 31; in pots, 33, 215, 281, 326, 414, 479, 525; early, 61; Laxton's Noble, 71; old *versus* young plants, 77; flavour of, 76; for forcing, 86, 133, 269, 459, 559; main crop and late, 99; selection of, 100; beds, old, 109; in 1887, 108; runners (last year's) 133; "rusted," 151; planting, 155, 182; effects of drought on, varieties, 157; alpinas, 174; preparing for forcing, crowns splitting, 269; plantations, mutching 4.1  
*Streptocarpus hybrids*, 89  
 Sud brooke Holme, Orchids at 382  
 Sutton Show, 147  
 Sunderland Parks, 274  
 Swanmore Park, 253

TABLE DECORATIONS AT RICH-moud, 8  
 Taunton Show, 145  
 Tea plant, the, 561  
 Tennis lawn, size of, 430  
 Tennis grounds, makin, 438  
*Tentredo adumbrata*, 194  
 Thames Ditton House, 169  
 Thomson's Vruc manure, 574  
 Thoughts on current topics, 6, 181; random, 512  
 Thrips, destroying, 219

Tobacco culture—in Kent, 236; conference on, 497  
 Tomatoes, 42; growing 123; without ventilation, 103; notes on, 135; the "Tree," 133; at Chiswick, 161; Earliest of All, 163 fine crops out of doors, 184; Carters' *Perfection* out of doors, 259; out of doors, 251; Chiswick trials of, 276; certificated, 278; Ham Green Favourite, 334; ripening late, 345; from cuttings, 345; di-seased, 350; fungus, 429; for the market, 441; Cardinal, 527; notes on, 569; the Peach and Puritan, 561  
 Tomato house, heating a, 219  
 Transplanting vegetables, 215  
 Trees in Loudou, 181; for the seaside, 284; on walls, regu-lating, 325  
 Trees and shrubs, late planting, 295; ornamental, 313  
 Tree Ferns, sale at Chiswick, 469  
 Treuching, effects of, 182  
*Tropæolum Mrs. Ellice*, 116  
 Trowbridge show, 167  
*Tryptera artemisia*, 523  
 Tulips for forcing, 234  
 Tuli, Tree, 424  
 Tweed Vineyards, Clovenfords, 323  
 Twickenham Gardens, 118  
 Twickenham Show, 16

UNDER GARDENERS AND PRIZES 495

VAN HOUTTE MEMORIAL prizes, 53  
*Vallota purpurea*, culture of, 432  
 Vegetables removing waste, 177; coarse, 354; competition at South Kensington, 367  
 Veitch Memorial medals, 567  
*Vicia Denesiana*, 494  
 Vines—horders and unorthodox pruning, 4, 52, 87, 133; summer treatment of, 27; seasonable notes on, 73; borders, wet, 123; the "Mauresa," 139; Hitting, 150, 193, 215, 328; insects of, 143; borders and Vine-pruning, 183; manure, Thomson's, 203; leaves withering, 218; methods of pruning, 230; in autumn, 259; shoots, more room for, 290; horder, compost for, 303; early forced, 302; methods of pruning, 317; and insects, 322; flowers, erect and deflexed stamens, 343; forcing, 345; rearing, unsatisfactory, 373; in pots, 336; a large, 425; borders, dresslag for, 469; rearing, 461; forcing, 473; planting, 432; pruning, 482; and mealy bug, 492; at

VINES—continued—  
 Garston, 527; horders, 517; pruning, early & late, 519; forcing, 571, 525; for late vinery, 552; fruiting in a year, 558  
 Vine of Kinaell, the great, 459  
 Vineries, ventilating, 241  
 Vinery, an amateur's, 259  
 Violas—bedding, lists of varie-ties, 199; 243, 270, 323, 422; notes on, 293, 337, 492, 443; the classification of, 377  
 Violets—cultivation, 292, 320; in winter, 49

WADDON HOUSE, 490  
 Wakefield Paxton Society, 8, 116, 259, 272; meeting of, 204, 516  
 Walkley Amateur Floral and Horticultural Society, 259  
 Walnuts, keeping, 233  
 Walnut trees coming into bear-ing, 395  
 Walks for a kitchen garden, 535, 422  
 Wallflowers, 574  
 Wall trees, winter dressing for, 571  
 Walls, fruit trees for, 512  
 Wasps—varieties of, 133; and fru t, destroying, 182, 204  
 Water, scarcity of, tanks, 131; and watering, 182; soft for gardens, 448  
 Watercress beds, 89  
 Watering plants in hot weather 104  
 Weather—in Notts, 139; notes on the, 336; the, in December, 539; chart, a, 539; at Christ-mas, 560  
 Weeds, 259  
 Weeping tree, a real, 337  
 Welsh Shows, 169  
 Wentworth Castle, 164  
 Weston-super Mare Show, 145  
 Wimbledon Show, 3  
 Wimbledon Horticultural So-ciety, annual meeting, 549  
 Wine, making from unripe Grapes, 375  
 Winning and losing prizes, 419  
 Winter—Greens, 53; *Aconite*, 272; in Scotland, 320, 515  
 Wood, 328  
 Woodwardsia, 110  
 Worms in soil, 123; in pots, ex-peeling, 432  
 Wylam, 315

YEAR, NOTES ON THE CLOS-ing, 557  
 Ye vs, Golden for hedges, 180  
 York Chrysanthemum Show, 2-4  
 York florists, annual dinner of the, 540  
*Yucca aloifolia variegata*, 294



## WOODCUTS.

	PAGE		PAGE		PAGE
Abberley Hall—Rockery and Tower .. .. .	319	Davallia tennifolia Veitchiana.. .. .	111	Odontoglossum Harryanum .. .. .	87
Adiantum dolabriforme .. .. .	225	Erica ampullacea .. .. .	95	"    Schroederianum .. .. .	257
Alnwick Castle .. .. .	297	"    mundula .. .. .	438	Oncidium dasystyle, Dr. Woodforde's variety .. .. .	493
Apple, Potts' Seedling .. .. .	505	"    Shannoniana .. .. .	94	Oxalis brasiliensis .. .. .	170
Ashburne House, Sunderland .. .. .	275	Foxglove, a peculiar .. .. .	5	Pæonia albiflora .. .. .	31
Carpet bed, a Jubilee .. .. .	249	Gelasine azurea .. .. .	357	"    officinalis lobata.. .. .	517
Castle Coch Vine .. .. .	428	Group, a challenge cup .. .. .	75	Peach, the Nectarine .. .. .	806
Cattleya citrina .. .. .	565	Hessian Fly .. .. .	176	Pear tree slug .. .. .	104
"    labiata Dowiana .. .. .	473	Holcyn Hall, Wylam .. .. .	341	Pope's Villa, Twickenham .. .. .	119
"    Lawrenciana rosea superba .. .. .	451	Holly bed at Alnwick Castle .. .. .	296	Primula Reidi .. .. .	52
Cecidomyia destructor .. .. .	176	Hull challenge plates .. .. .	311	Raby Castle .. .. .	157
Chrysanthemums at Chilwell .. .. .	519	Hydrangea stellata flore pleno.. .. .	203	Schubertia grandiflora .. .. .	497
Chrysanthemum blooms, contrivance for measuring..	389	Inula glandulosa .. .. .	274	Sophracattieya Batemanniana.. .. .	472
"    Edouard Audiguier .. .. .	363	Jesmond Dene, Newcastle-on-Tyne .. .. .	187	Strawberry Laxton's Noble .. .. .	71
"    Edwin Molyneux .. .. .	542	Læla Batemanniana .. .. .	55	Styrax japonica .. .. .	29
"    Mr. H. Cannell .. .. .	543	Lambton Castle Gardens.. .. .	208	Tenthredo adumbrata (larva and perfect insect) .. .. .	104
"    Mrs. J. Wright .. .. .	385	Lilac Marie Lequay .. .. .	11	Trees and shrubs, appliances for transplanting .. .. .	266
Cragside, Rothbury .. .. .	253	Manresa Vine .. .. .	140	Vine, the Manresa.. .. .	140
Crinum Hildebrandti .. .. .	406	Microsperma bartonioides .. .. .	562	"    flowers of the .. .. .	343
"    Kirki.. .. .	407	Mina lobata .. .. .	335	Vine at Castle Coch .. .. .	428
Cypripedium orphanum .. .. .	135	Newton Hall .. .. .	344	Wentworth Castle Flower Garden .. .. .	165
"    præstans .. .. .	179	Oatlands Lodge .. .. .	33		





## COMING EVENTS

7	TH	Bath, Farnham, Farningham, Ipswich, Malvern, Reigate, and Winchester
8	F	Hitchin and Maidstone Shows.
9	S	Crystal Palace Show. [Rose Shows.]
10	SUN	5TH SUNDAY AFTER TRINITY.
11	M	
12	To	Royal Horticultural Society. Committees at 11 A.M.
13	W	Edinburgh Rose Show (N.R.S.).

## NOTES FOR DRY WEATHER.

**W**HAT is best to be done in weather such as we have experienced up to the present time is somewhat puzzling to determine with satisfaction to ourselves and with benefit to the objects of our charge. The thermometer gives daily indications of higher temperatures than have been known for many years. On one day in the walled garden over 90° in the shade was indicated, and the general daily range is either 80° or over it. A soft breeze somewhat tempers the heat, so that animals are less heavily burdened than might have been. But alas! for the flowers. The surface of the soil is a layer of heated dust, and the breeze, so grateful to man and beast, is only another item which goes to break up the life of the plant.

It is a rule with the inexperienced to fly to the watering pot in seasons of drought, and there is no gainsaying the utility of the application of water. Given heat and abundance of water, with manurial agents in due proportion, we secure an abundant growth. Therefore the rule is a good one. But in a large garden with pot plants, fruit houses, flower gardens, shrubberies, &c., each calling for attention, with a supply of labour power and of water itself inadequate to the requirements of the place, there must be some modification of the rule.

It may therefore be of service to look at what must be watered, and the best method of supporting plants in very dry weather, and as a means of helping them to pass through a period of drought with as little damage as possible. It goes without saying that all plants in pots and in borders must be watered, but although that is a patent fact there are methods of management which help to save both labour and water. Though apparently paradoxical, a good way to save water is to apply it to plants before the soil turns to dryness. I found out this truth through experience in the dry seasons which occurred before and after 1870. Many of the plants in large pots required water three times a day, the water had to be conveyed a good distance by manual labour, and consequently the easiest method was in favour. I do not wish it to be inferred that the reason for watering before dryness was apparent was because it saved labour. It was thought to be better for the well-being of the plants to keep them constantly moist, and it was only found out in a secondary way that less water was required to do this than when the soil was allowed to become dry before watering. Experience since then has repeatedly proved this to be the case. It is much better for plants no matter whether in pots or in borders, outdoors or in, and better for all kinds of things requiring to be watered—even shrubs—to give it

before dryness, and in all cases it takes less water and therefore less labour.

Shade from direct sunshine is also of importance. In such strong heat as has come upon us plants do not suffer from the direct rays of the sun being denied them, perhaps the opposite; at any rate they do with less water. Then the pots of plants which are exposed should be protected. This is doubtless most efficiently secured by plunging in earth or other material. I have also found it of benefit to mulch the surface of pots with some light open material. With regard to borders, no approach to dryness should be allowed, and by all means they ought to be mulched. Flower beds or borders requiring water should in each case be treated on their merits. Where plants are large and closely set together water the whole of the ground. If the plants are not very deeply rooted give about 1 to 1½ inch. If down to a good depth as much as 3 inches will be none too much. When half-dried the ground must be hoed slightly over the surface. There are slightly over 6 gallons of water in a cubic foot. An inch of water is therefore provided by applying 1 gallon to every 2 feet by 1 foot of surface; but in the case of smaller plants, and where it would be wasteful to soak the ground, the best method is either to draw drills by removing the dry surface soil and pouring the water therein, or the dry soil may be removed from round each plant, a basin formed, and the water poured in. The dry soil in both cases is drawn over the watered portion, and thus in some measure forms a mulching.

It may be noted that of the commoner bedding plants those that it is most necessary to water are Calceolarias, Violas, Lobelias, Ageratums, Golden Feather, Iresines, and Alternantheras. When once started into growth, Pelargoniums, Königa, Marguerites, Grasses, and succulents do fairly well without watering. It is of the greatest benefit to all flowering plants to remove regularly flowers which are beginning to decay. Soil which has been well firmed where at all inclined to be naturally open is less liable to get dry, and retains water longer than if left loose.

With regard to shrubs, it is doubtful if there is a more neglected class in times of drought, and certainly none suffer more permanently where neglected. There are some soils where shrubs thrive so well that it is only necessary to plant and they will grow through all changes of weather. We are not fortunate in a kind soil of that nature. In the best qualities water is found to act most beneficially, and in the worst—mostly pure sand or gravel—we find it necessary to water shrubs for a few years during times of drought. Some species require more water than others. For instance, Coniferæ once started fairly may be left to take care of themselves. Portugal Laurels are worse to establish than any others of the family. Yews generally take a large amount of attention, Irish Yews being the least easy to manage. With Rhododendrons it is very much a question of soil. We have those that have become strong healthy plants without requiring any water other than rain, and others which have needed looking to for several seasons. Again, in watering shrubs it is essential that the condition of the roots be well known, for a plant with a ball of healthy roots requires more at a time, but less often than another does with a poor ball, or none at all, and few roots. A well-planted shrub should have had the soil surrounding its roots well broken, and this as well as the ball must be moistened. In light soils, they should be planted a little below the level, and a basin left for watering. A little



loose soil drawn over that which has been moistened is of great help. The soil should in no case be allowed to become dry, much less water being required to moisten in the one case than in the other, and the plants can be sooner left to themselves. The quantity we give to each varies according to size, &c. Most plants 3 feet high need at least 2 to 3 gallons at a time. Large-balled specimens have as much as from 40 to 60. Very sandy soil may need water twice a week, soil of better quality from once a week to once a fortnight.

With regard to vegetables, deep trenching and the employment of plenty of good fresh manure is of the greatest help in tiding over a period of drought. It is also of importance that vegetables, especially in light soils, should be deeply planted or sown. All our Peas, as an instance in point, are sown in trenches. The roots are down out of reach of dryness, as shown by the robust growth made by those from every sowing. In hot weather, however, it is well to help the plants by cutting off the tops when sufficient flowers are opened for a full crop. A soaking of water is also advantageous when the pods are swelling. Broccolis, Cauliflowers, Brussels Sprouts, Lettuces, Leeks, &c., never get more than one watering, and that to establish them when planted, but the precaution is taken of drawing aside the loose dry soil when planting, so that the roots get well into the moist stratum below, and when finished the dry soil is drawn back as a mulching.

Seed-sowing in dry weather is rendered quite a satisfactory process if the drills are well watered before sowing and the seeds covered at once. Mats laid over beds help wonderfully in causing a good seed to braird. In the case of Spinach we find it of advantage to give a good dressing of Mushroom bed refuse underneath the place where the rows are to be. This, well moistened before sowing, causes a good leafage.

Fruit trees we do not as a rule need to water, but those who employ rough turf should see to it that plenty of water is given, as this material has a tendency to become very dry.—B.

### THE GARDENERS' ORPHAN FUND.

WHEN Mr. Charles Penny, of Sandringham, made a proposition in our columns for the establishment of a Gardeners' Orphanage, commemorative of the fiftieth year of Her Majesty's reign, we gave a welcome to the proposition as one good in itself, but in that particular form impracticable; and suggested that much more good could be done in a manner that could be devised by a central committee, with the contributions of the well disposed, without expending them on a necessarily costly building. No one was more ready than Mr. Penny to place the matter in the hands of a committee and to acquiesce in whatever decision might be arrived at.

On the appointment of a provisional committee it was first determined to test the feeling of gardeners on the subject of raising a fund for the succour of children that might be left helpless, and the response, though it did not equal the anticipations of some members, exceeded that of others, yet on the whole was regarded as sufficiently encouraging to justify further action in the matter with a view to establishing the movement on a sound basis.

On full consideration of the whole subject, the building project was abandoned, and attention concentrated on the establishment of a fund that should be entirely devoted to relieving the necessities of the orphans of gardeners; and on this basis a sub-committee was appointed for framing rules to be submitted to a general meeting that is to be held on the 12th inst. at South Kensington, for the management of the fund. In this important work the committee had the advantage of a chairman of great industry and business capacity, Mr. G. Deal (of the firm of Messrs. John Weeks & Co.), and after several meetings the rules in question were formulated.

As it is thought desirable that those rules at least that bear directly on the collection and distribution of the moneys composing the fund, be made known to the great body of gardeners and

sympathisers with the object, we have had placed at our disposal an advance copy for bringing them before the public prior to their presentation to the general meeting alluded to.

Rule I. is merely descriptive of the title of the fund.

II.—OBJECTS.—The objects of the fund shall be to make allowances or grants of money (in accordance with Rules 13 and 14), to aid in the maintenance of the orphans of gardeners, foremen in gardens, and the managers or departmental foremen in nursery and seed establishments.

III.—MEMBERSHIP.—Any person contributing 5s. or more per annum shall be a "subscriber;" and a donor of £5 or more shall be a "life subscriber." Local associations or corporate bodies contributing to the fund £5 or more shall, for a period of fifteen years, exercise the same right of voting as a life subscriber. Annual subscriptions to be paid in advance, and shall be due on the first day of January.

IV.—MANAGEMENT.—At the first general meeting of the subscribers to the fund, a governing body shall be elected, to consist of a president, vice-presidents, three trustees, a treasurer, secretary, two auditors, and an executive committee of twenty-four subscribers, with power to add to their number, five to form a quorum. The president, trustees, treasurer, secretary, and the secretaries of local committees, shall be *ex officio* members of the executive committee; and the treasurer and secretary shall continue in office for one year, and shall be eligible for re-election at the annual general meeting. One-third of the members elected on the executive committee and one of the auditors shall retire in rotation each year, and the vacancies so occasioned shall be filled at the annual general meeting. The retiring members shall be eligible for re-election. The executive committee shall have power to fill any vacancy that may occur during the current year.

V.—FUNDS.—No part of the general funds shall be used for the purpose of erecting any building of whatever kind; but should the fund at any future time assume such proportions as to render it desirable to erect or purchase a building, special arrangements can then be made for the purpose. All donations and legacies, and such proportion of the annual subscriptions as shall be sanctioned by the executive committee, shall be invested in the names of the trustees, on the authority of the committee, endorsed by the signature of the treasurer. The trustees and treasurer shall at all times, when requested by the executive committee, give such information concerning the funds in their hands as the committee may require.

\* \* \* \* \*

XI.—QUALIFICATIONS OF CANDIDATES.—All candidates must be (1) orphans of persons who have been gardeners, foremen in gardens, or managers or departmental foremen in nursery or seed establishments; and (2) must be nominated by two subscribers to the fund, who shall furnish to the executive committee such information respecting their nominee as the committee may require. The committee shall decide upon the definition of the words "gardener," "foreman," "manager," &c., and shall also decide generally upon the validity of the qualification of candidates.

XII.—MODE OF ELECTION.—Candidates shall be elected by the votes of the subscribers at the annual general meeting. Subscribers of 5s. per annum shall be entitled to one vote at each election; subscribers of 10s. to two votes; of £1 to four votes; of £2 to eight votes, and so on in like proportion. Life subscriptions of £5 shall entitle the donors to one vote at every election; of £10 to two votes; of £20 to four votes, and so on in proportion. Any person or persons contributing special donations or payments other than annual subscriptions to the amount of £60, may place, without election, one orphan on the fund for an allowance of 5s. per week for a period of six years. The votes recorded in favour of unsuccessful candidates shall be carried forward to their credit in succeeding elections; and in the event of the death of a candidate after the publication of the voting papers, and before the date of election, the votes given to the deceased candidate shall be credited to a brother or sister, if eligible. Before the annual general meeting the executive committee shall examine the claims and qualifications of candidates, and prepare an approved list of those eligible, and from this list the election shall be made. A copy of the list and voting papers shall be sent to each person entitled to vote at least fourteen days before the day of the election.

XIII.—ALLOWANCES.—The allowances shall consist of any sum not exceeding 5s. per week to children under the age of fourteen years who, within the knowledge of the executive committee, may be placed with relatives or other responsible persons acting as guardians. Allowances shall be paid quarterly, in advance, except when the committee may consider it desirable to make other arrangements. No child shall receive annual support after having attained the age of fourteen years; but the executive committee, at their discretion, shall have power to grant a sum, not exceeding £10, towards apprenticing, or otherwise promoting the start in life of any orphan on whose behalf application shall have been made to the committee. The committee shall also have power to grant, on application, a sum not exceeding £2 to any orphan who may have ceased to be chargeable to the fund, and who shall have given evidence of his or her satisfactory conduct during the subsequent twelve months. The

executive committee shall have power to suspend allowances where the circumstances of candidates have been misrepresented, or have since altered so as to render further assistance unnecessary. Arrangements may be made by the executive committee for placing the children elected to the benefits of the fund, either with carefully selected foster parents as cottage-boarders, or with the master or mistress of a school or institution, who shall be required to furnish satisfactory security for the proper discharge of their duties. The duties shall be to board, lodge, clothe, educate (finding all books), to do the washing, mending, and all that is necessary for maintaining and educating (including medical attendance and medicine) such child or children as may be placed in their care for the term of years agreed upon. The committee shall have power to remove such child, or children, at any time should circumstances arise which would render it desirable to do so, and such foster-parent, or master, or mistress shall not be allowed to relinquish the charge of any child or children under their care unless by special permission of the executive committee. The provisions and clothing shall be thoroughly good in quality, and samples shall be produced for the inspection of the committee when required.

XIV.—SPECIAL GRANTS.—The executive committee may, if they see fit, make special grants in cases of extreme urgency to orphans not elected to the fund, but such grants shall in no case exceed the sum of 2s. 6d. per week for one year.

Rules VI., VII., VIII., IX., and X. are of a routine character, and refer to the investment of moneys, the duties of trustees, treasurer, secretary, auditing of accounts, and the holding of the annual general meetings.

It will be seen that the Gardeners' Orphan Fund will shortly be an established fact and will take its place amongst other good institutions in the country. The benefits it will confer must obviously be controlled by the support that is accorded, and this it is hoped will be great, and that young as well as gardeners of long experience will regard it as worthy of their support.

We may add that persons who have had wide experience in the founding of benevolent societies express the opinion that the Gardeners' Orphan Fund will commence its career under conditions decidedly more favourable than pertained to the founding of many existing institutions that have secured a strongly established position and dispense assistance to persons who are entitled to share in their benefits.

The Gardeners' Orphan Fund is not an opponent of, but an ally to, other agencies that grant aid in the time of adversity; and we believe the active Secretary of the Gardeners' Royal Benevolent Institution, which affords the means of support to aged gardeners and widows of gardeners, is a contributor to the younger fund that is intended to minister to the wants of gardeners' children who may be left, as many are left, without the means of subsistence.

The co-operation of gardeners of all grades, and of persons who are engaged in trades and industries connected with horticulture, is desired for this excellent object, and it is believed that the fund being established their support will not be looked for in vain. Already good friends and substantial helpers are enrolled, and a favourable report is expected to be submitted to the general meeting by the chairmen of the provisional and sub-committees that have endeavoured to place the matter on a business footing. The secretaries and members of these committees having finished the preliminary work they were appointed to do will then resign their positions, but we believe they are willing to give their services to the fund if elected by the subscribers present at the meeting in question.

At this meeting Sir Julian Goldsmid, Bart., M.P., the nominated President of the fund, is expected to preside, and all subscribers and intending subscribers to the fund are cordially invited to attend. The exact time of the meeting has not yet been fixed, but it will probably be soon after the Fruit and Floral Committees rise, which is usually before one o'clock.

### TUBEROUS BEGONIAS AT FOREST HILL.

AN astonishing example of the progress made in the improvement of Tuberous Begonias can now be seen in the houses of Messrs. J. Laing and Co.'s Stanstead Park Nursery, Forest Hill, and all those who are interested in, these handsome plants would do well to take a journey thither. We cannot point to any group of plants in which such a wonderful development has been effected within the same short period, for Tuberous Begonias have now become almost indispensable in thousands of gardens where they were unknown a few years since. When Messrs. Laing & Co. issued their first coloured illustration of their best varieties nine or ten years ago, the incredulous thought the artist had given full scope to his imagination, and some even ventured to say that one of the best formed flowers was an impossibility. The doubters have long since been silenced, and now, so great has been the advance, those varieties would not be tolerated in a fourth class garden, and even those engaged in the work had no conception at the time what grand results they would ultimately secure. No better instance could be given to show the effects produced by a continuous, intelligent, persevering

course of crossing and selection with a limited number of forms to start with than is found in the Tuberous Begonias of the present time. Year by year it has seemed that the limits of improvement had been reached, the finest varieties only were distinguished by names, and each season the selection of those to be so honoured was more rigorous. This season still further progress is evident, and the raisers are almost disposed to give up naming as regards the single varieties, for the difficulty of making a selection where all are of such nearly equal merit is too great.

Having attained so large a measure of success with the single varieties, Messrs. Laing & Co. turned their attention specially to the double forms, and now a corresponding advance is being made with them. Charming symmetrical blooms are seen in profusion, which for their regularity of forms and richness of colours are entitled to rank amongst the best of florists' flowers. For placing on elevated stages in pots suspended from the roof, or in baskets, most of these varieties are admirably adapted, owing to their flowers drooping gracefully from the stems. When arranged on a low level stage the plants are not seen to the best advantage, and at a first glance it might be supposed that the colours were not nearly so bright as they really are, because the back part of the flowers only is seen. The shades are in fact as varied, delicate, bright, or rich as in the majority of the single forms, and there is a neatness about the better forms that is particularly pleasing. Another good point is that the flowers are excellent for cutting, standing remarkably well when placed in water, and in some cases they bear carriage better than the others. One sturdy compact variety has been secured which holds its blooms very firmly and more erect than the others; it will make a useful decorative plant, and will probably be largely propagated for another season. From a host of varieties a dozen "Jubilee double Begonias" have been selected for distribution this season, named as follows:—Alba fimbriata, a beautiful white variety, very full, symmetrical, with petals fringed like the well-known Camellia of the same name, of which it might be considered a reproduction on a smaller scale. Alba magna is another handsome double white variety of great size and excellent form; Alba rosea is pretty and very distinct, bright rose with a white centre; Jubilee has large, deep, rosy crimson flowers, very full; Lady Lennox is one of the best of the double yellows, bright in colour and capital in form and substance; Lillie, a charmingly symmetrical flower, like a diminutive Camellia, rosy salmon with a white centre; Little Beauty, also remarkable for its beautiful form, pale rose with lighter centre; Lord Loughborough, a grand variety, brilliant scarlet; Lord Randolph, crimson, full and beautiful; Marchioness of Stafford, a fine flower, creamy white; Marquis of Stafford, rich crimson, very effective; Mrs. Amy Adcock, reddish salmon, white centre, very distinct and handsome.

For another season a group of novelties is being formed amongst the double varieties in which the petals are beautifully undulated, imparting a crisped appearance to the blooms that is quite unique. Several of these have not yet been named, but they will be certain to become general favourites. Of the recent double varieties, many of which have been honoured with two and three certificates each, the following deserve notice:—Blanche Duval, creamy white; Clemence Denizard, rich rose; Comtesse Horace de Choiseul, white and rose; Formosa, rich crimson, white centre, large drooping flowers, one of the best for a basket; Goliath, crimson, large and full; Lord Mayor, rich rose, another fine basket variety; Madame Arnoult, rosy salmon, very beautiful; Mrs. Howe, salmon mauve, white centre; Prince Albert Victor, bright crimson; Prince of Wales, a grand crimson variety, which has been awarded three first-class certificates; Robin Adair, brilliant crimson, excellent form and free. As a curiosity a variety named viridiflora deserves a line or two of description. The axis of the flower has elongated and some of the petals are wholly or partially transformed into miniature leaves, in some cases the lower portion retaining the colour and texture of the petals, the upper that of the true leaves. In another form of the same type, in which there is a combination of rose and green in a similar way, the effect is peculiar and even pleasing. Those interested in abnormal forms of this character would find a subject worth their attention in these varieties.

A larger span-roofed house is appropriated to the single Begonias, 100 feet long and 25 feet wide, with a central and two side stages. In this structure a most brilliant effect is produced, dazzling to the beholder, especially on a bright sunny day. The flowers are of remarkable size, 5 to 7 inches in diameter, with hundreds 6 inches across, the petals broad, rounded, massive, 3½ inches in diameter. The colours comprise varied shades of scarlet, orange, yellow, and cream to white, with dark and light crimson, rose, pink, and blush. Extremely elegant are those in which the petals are margined with rose more or less deeply, with the centre white; in some the colour is confined to a narrow picotee-like edge, in others extends to half the depth of the petal, but all are attractive. One remarkable variety suspended in a basket from the roof of this house is very conspicuous. The flowers are 6 inches in diameter, very open, of a deep rose, and borne in spikes of eight to ten, which, drooping round the plant, give a magnificent appearance. The "Royal" Begonias represent the cream of the single varieties both in shape, size, and colours. They are as follows:—Queen Victoria, rich rose, very large; Prince of Wales, scarlet-crimson; Princess of Wales, rich rose; Prince Albert Victor, scarlet with orange; Princess Louise, pure white, excellent shape; Princess Victoria, rosy crimson margin and light centre; Duke of Edinburgh, maroon, one of the darkest flowers yet obtained; Duchess of Edinburgh, yellow shaded with orange.

As already stated the unnamed plants comprise some excellent addi-

tions to those already obtained. They are all seedlings raised in January, 1886, were planted out in the beds which produced such a grand display last summer, carefully selected and assorted, and potted for exhibition and stock this season. Another series of seedlings early raised this year have been just planted in the beds for the present season's outdoor display, and as 100,000 have been so accommodated, it can be imagined that there will be something to be seen in a few weeks' time. The main portion of the ground near the road contains 50,000 plants, the beds being at right angles with the road instead of parallel as last year, with a few plants of the variegated Maize in the centre to relieve the colours and improve the general effect.

Messrs. J. Laing & Co. have done valuable work in several departments, but they conferred a boon on cultivators when they took the Tuberosus Begonia in hand.—VISITOR.

### VINE BORDERS AND UNORTHODOX PRUNING.

I AM indebted to Mr. Abbey for another review, not so elaborate as the former one that I had the pleasure to acknowledge, nor, perhaps, so perspicuous; but he has no doubt done his best to prove me wrong in my advocacy of long-pruning Vines under certain specified conditions; and not only so, but for my frankly giving whatever credit there might be due to border influences in improving the Grapes referred to. I take that as a compliment, and have not the slightest objection to being made a victim in such a case.

Mr. Abbey is a very clever man. He evidently knows more about Vines he has never seen than I do who have examined them as carefully and critically as my eyesight and mental state permitted; and perhaps I may add, the examination was made in broad daylight. If ever I envied a man it must be Mr. Abbey. I have been inspecting Vines, studying Vines, working amongst Vines for I scarcely know how many years, and trying in every way to understand them, not only generally but the individual peculiarities of peculiar Vines, and yet here I am humbled to the dust by my incapacity. It is a misfortune that I must bear as well as I can. Of one thing I have no hope, and that is of understanding more about anything I have never seen than of what I have examined. I am no match for Mr. Abbey in that respect, and quietly take a back seat.

As my signature indicates, in what I write now and then I simply give the teachings of experience. I record results, and as far as is ascertainable, the practice that led to them. If I find barren Vines made fruitful by a small departure from professional routine, I am apt—it may be presumptuous—to think the orthodox methods of orthodox men may possibly be a little faulty. Mr. Abbey is very orthodox, even severely so, judging from his critique; theoretical and scientific too—that seems apparent. I have met several scientific men in my time, who were great in theory and all theologies. I always hoped they were happy, but when I have found them labouring to prove that something that actually is could not be, I have preferred the experience that was productive to the philosophy that was barren.

Mr. Abbey will perhaps allow me to express my suspicion of his having a scientific bee in his bonnet on this question of Vine-pruning. It seems to me tolerably clear that he lacks some experience on the process to which I have directed attention—experience that some good Grape-growers have profited by. Has Mr. Abbey ever heard of Mr. Henderson of Cole Orton Hall? I daresay he has. Has he seen the medals won for Grapes by that fine old gardener? Perhaps not. I have. It was a wonderful display, possibly unequalled. I have seen the Vines, too, that produced the Grapes that won the medals. Possibly Mr. Abbey has not. I hope at least he did not inspect them after pruning, or his nervous system might have received a great shock, for, sad to say, from his point of view, they were pruned on the unorthodox system that I have had the audacity to advocate and which Mr. Abbey condemns. "Oh," but our friend says, "such pruning is contrary to science, the extension making loose bunches, badly set, stoneless berries, Grapes deficient in colour, not finished and shanked." That is his verdict on Vines pruned in the free manner described. But against that dictum are the medals, including the only £20 one I believe ever offered and won for Grapes. I am an old-fashioned believer in success, and take it to be more expressive of good treatment than philosophical argument with nothing tangible at the end of it except a good signature.

Mr. Abbey is great in big words. They are enough to frighten a young and timid man; but luckily I do not happen to be either very young or nervously timid, so can look at them calmly in all their imposing array—assimilation and alimentation, and elaboration, and solidification, and nitrogenisation, and organisation, and mineralisation—all in one article. I have altered the terminals a little of some of them for the sake of euphony, but they are all there on page 526. They are almost ponderous enough to shake the fruit off Vines that were not pruned on the orthodox system. But they were not uttered when Mr. Henderson was winning prizes against all comers with Grapes that ought to have been loose, irregular, badly coloured, and shanked, according to the erudite deductions of Mr. Abbey. I am quite sure he wanted me to "review" his review, and I am trying to oblige him as well as I can.

Since writing the above I have found a reference in the Journal to the Cole Orton Grapes which is perhaps worth quoting:—

"Entering the walled garden, which is about two acres, we see the vinerics on the south wall, and could not resist the involuntary mental inquiry, Are these the structures which for a quarter of a century produced the Grapes which won so many prizes and medals at the Royal

Horticultural, Royal Botanic, and other Societies' shows? The houses are neither large, lengthy, nor lofty, but just such commonplace erections as were placed in ordinary gardens half a century ago, and the Vines are certainly as old-fashioned as the houses. Their gaunt stems rise from the ground, and their branches are trained 'any way,' one Vine covering a roof and the shoots disposed according to the one governing condition that the foliage can have light. They are pruned, too, on 'no principle,' as some might call it, yet on the principle of selecting and cutting to the best eyes, let them be situated where they may. That is how, so far as regards training and pruning, Mr. Henderson has 'swept the boards' on so many occasions by the splendid quality and superb finish of his Grapes. It may be urged that this mode of culture is without 'system,' but rather should it be regarded as the fruit-producing and prize-winning system of which Mrs. Henderson, with just and commendable pride, did what the veteran did not care to do—gave abundant proof by such a display of gold medals as have probably never been won by one man. Mr. Henderson showed until he was tired of showing, and won until he was tired of winning, but he grows good Grapes by his old 'no system' mode of culture, and on the same old Vines.

But also in worse than these old houses, or at least in a structure still more unlikely and uninviting, have some of the conquering Grapes been produced. And now I am going to state something wonderful, almost incredible, yet true. At the end of the vinerics is an old brick pit. It was once a Pine pit heated by dung, the bottom being arched forming a chamber beneath in which to place manure. Thirty years ago Mr. Henderson converted this brick frame (for that is what it is) into a vinery by placing in it a little more than a foot of soil and planting with Vines, the canes being trained near the glass. The pit is now heated by a hot-water-pipe (no bottom heat), the lights push up and down—there are twelve of them—and the bed in which the Vines (seven) are planted is 7 feet wide. It is from this homely pit that the aristocratic Grapes have come. And now for the marvel—this twelve-light pit has produced Grapes which have won prizes of the value of £300. Is not this an achievement unparalleled in the annals of Grape culture? Eleven pounds of fruit to the square yard of glass is the annual produce of this pit. The canes are trained 'any way,' and pruned as before to the 'best eyes.' The wood is stout and exceedingly short-jointed, and the foliage in October possessed the thick leathery texture of that of the Fig. It is hardly necessary to say that these Vines have been top-dressed and fed with the right food, and in right quantity, and at the right time."

Seize on that word "top dressing," Mr. Abbey, and make the best of it. Every sensible man does the best he can for the Vines in his charge; but the great fact remains that the unorthodox pruning did not prevent the finest crops of the best Grapes being produced; and Mr. Henderson told me he was quite certain that he could not have produced such a weight of fine fruit if pruning had been conducted on the rule-of-thumb system that is called scientific, whereas in instances innumerable where close pruning is rigidly adhered to regardless of the condition of the Vines it is exactly the reverse, for it is thoughtless, foolish, wasteful, and barbarous.

If Mr. Sanders was wrong in his method of pruning old Vines at The Firs, the change resulting in such marked improvement in the estimation of all who saw them, Mr. Henderson must have been wrong also; but I am fully convinced both were right. Mr. Sanders in my opinion acted very wisely in doing what he could in dressing the border, and also in not closely spurring his Vines; and here let me remind Mr. Abbey that he is totally at fault in the assumption that the top-dressing on the outside six-foot border influenced the rooting of the Vines from the "collar," for there is a wall between the stems and the lime dressing. It is sometimes better to see after all than to found an argument on a guess, and that a wrong one.

Mr. Abbey has conveniently overlooked a statement in the article he criticises that demonstrates the advantages of long over close spur-pruning much more conclusively than the Vines do that he concludes have been "rejuvenated." It is true they have been greatly improved, and mainly by the change in pruning; but we will pass to a small house with no outside border to improve, and the roof covered with an old Muscat Vine. On some parts of that Vine close pruning was adhered to, but not all, and where it was not there the best Grapes hang unmistakably. But Mr. Abbey had perhaps better not go and see them, for fear he should witness the breakdown of his argument; still if he would like to run the risk, I shall be glad to accompany him if we can arrange for an outing together. I forget, though, it does not appear to be necessary for him to inspect the Vines, he knows all about them without going to that trouble; but I wonder why he so complacently ignored a statement of fact showing that the improvement of the crop on the Vine in question was the result of a change in pruning, and in pruning alone.

I have stated as clearly as I am able to state anything, that when Vines root freely near the surface of a good border, and the growths are trained thinly and the foliage kept clean, that they bear admirably on the close pruning system, and I have been particular to advise an adherence to the method that is satisfactory. It is only where there are no results, or bad results, from the existing rule-of-thumb routine that a change is advocated—a change that cannot do harm, and which I know in many cases has doubled, and much more than doubled, the previous crop of Grapes the first season, nothing whatever having been done to the roots of the Vines. With the roots under control and not neglected I have pruned Vines as closely as they could be pruned for years, and had Grapes that no one grumbled at; but at another time I have had Vines under my charge where border renovation was positively



prohibited, and to have pruned the Vines on the orthodox system would have been orthodox nonsense. They would not bear on the close spur, and the owner of the Vines wanted Grapes. He did not pay me for cutting off the laterals as close as it could be done, and if I had foolishly persisted in following that plan I should have had to adopt the extension system by extending myself off the premises.

If Mr. Abbey does not know there are dozens of vineries in which the Vines cannot have fresh soil and new borders, no matter for what reason, he is in blissful ignorance of circumstances with which many readers of this "defence" are familiar. His lot has been cast in pleasant places. Trusted, as I am sure he deserves to be, to do what he deems best, he has not known what it is to labour under difficulties. He steps from place to place with a little enjoyable rest between, and enters on fresh duties like a giant refreshed. I hope he will always have scope for his abilities, and will teach sound doctrine; but he will have to shake the bee out of his bonnet on Vine pruning before he can meet the wants of workers under difficulties—the very persons who are in need of guidance from which they can derive substantial benefit.

It would not be difficult to adduce more evidence of a departure from the system of closely spurring Vines proving highly satisfactory, and to refer to one authority that I believe even Mr. Abbey cannot ignore; but a consciousness of incurring a literary castigation for this my temerity renders it prudent to reserve something to counteract its effect, therefore at present I only add two words more—EXPERIENTIA DOCET.

### ROSES IN SUMMER.

So far, the present season has not been in favour of Roses in South Wales; the winter was long, the spring cold, the summer until now excessively hot and dry. In some parts, notably at Swansea, there is a water famine, and although some may recommend watering Roses, it is, under such circumstances, no easy matter to accomplish. Indeed I fear that Roses cultivated in a general way, and without any special appliances, will be very inferior in many parts this year, and cultivators will do well to treat them in such a way as to secure autumn blooms, and improve the plants, if possible, for next year.

No Roses will succeed in light or poor soil. They may appear fresh and green in early summer, but as soon as a slight drought occurs in June or July they shrink, and cease to grow or open their buds. Where the soil is light, and little or nothing can be done to make it heavy, extra manuring ought to be applied. A large quantity of rich manure should be dug into the soil near the roots early in the year, and when the hot dry weather begins, mulch heavily on the surface. Some object to mulching, as it gives the beds and borders an untidy appearance, but that is nothing if good blooms, and plenty of them, can be secured. It matters not what kind of soil recently planted Roses are growing in, they should all be well mulched at the present time. If liberal supplies of water can be given them excellent results will follow, but mulching saves watering to a great extent. Good manure is excellent for mulching when it can be watered, but when this cannot be done any light material, such as lawn mowings, will answer the purpose, as the main object is to prevent the roots being dried too much. Unless Roses make considerable wood in May and the fore part of June they will never bloom well at this time, and unless strong shoots are produced from now until the middle of August or later, autumn blooms will be deficient. Where the blooms are very poor now, and the returns altogether disappointing, the best way will be to pick off the buds and blooms, mulch and water heavily, and encourage the production of strong growths to bloom in autumn. It will be found that these will expand, gaining size, colour, and fragrance, which cannot be secured on poor plants at the present time. Red spider is very apt to damage the foliage of Roses, and its presence is indicated by the leaves becoming pale in colour and of an unhealthy appearance. Shoots badly infested will not make much progress, and they ought to be cleaned, if possible, by a frequent use of the syringe. The evening is the best time to syringe at this season, as the foliage retains the moisture throughout the night.

Many Roses throw up suckers from their stocks at this time. The shoots of these are always liable to be infested with insects, and worse than this, they rob the plant of much substance; in fact they are worse than useless, and every one should be cut off as soon as they appear. Old blooms and seed pods are not beneficial to the plants, and they should be removed once or twice weekly. We find *Maréchal Niel* bloom very much better when confined to forming a number of very strong shoots than when allowed to make a host of small twigs, and if those who do not succeed with it well would cut away the majority of the small shoots, and encourage the growth of a number of very strong ones, they would find them produce many grand blooms in the spring. This applies to *Maréchal Niel* in the open air and under glass, but it is important that the shoots form early, as they must be well ripened in the autumn.

All Roses which have a tendency to bloom best on long strong shoots should be treated in this way when they are making their growth. Climbing *Devoniensis* is a splendid white Rose when properly grown, but it does not flower freely if restricted, and the best way is to allow it plenty of headway. There is a plant of it growing against Margam Church, which borders the pleasure grounds here. It has grown up 20 feet or more, and of late it has been producing armfuls of charming blooms.

As a cottage or villa Rose in June, or indeed from May until October, none surpasses *Gloire de Dijon*. The fronts of some of the small houses about here have lately been covered with its massive buff blossoms, and let the weather be what it may, they never fail or disappoint. I should like to see *Cheshunt Hybrid* planted as a companion to it everywhere, as it is almost as free in growth, quite as free in blooming, and its large bright flowers are charming in colour and exceedingly fragrant. When it comes to a question of cut



Fig 1.—A peculiar Foxglove.

Roses, it is a difficult matter to secure large, perfectly formed, and coloured blooms in the glare of the sun, but if half-expanded blooms are cut about 7 A.M., and placed in water in the shade, they open beautifully.—J. MUIR, *Margam Park, South Wales*.

### A PECULIAR FOXGLOVE.

ABNORMAL floral forms occasionally occur in the common Foxglove, *Digitalis purpurea*, as in other plants with irregular monopetalous corollas, and the tendency is commonly towards a regularity of form, as in *Linaria vulgaris* var. *Peloria*. In the Foxglove represented in the woodcut (fig. 1), the corolla has become greatly enlarged and split up into spreading segments, beautifully spotted and very handsome. Mr. E. M. Holmes, F.L.S., curator of the Pharmaceutical Society's Museum, has kindly brought this specimen to our notice and submits the following description.

"This *Digitalis* was grown in a garden at Bush Hill Park Farm, Kent.

There are more than fifty stems of *Digitalis* in the garden, but no other inclining to this formation. This plant has one central stem, and four more slender (growing from the ground) offshoots, which have fewer flowers. Each of these five stems terminates in a monstrous flower, which is circular campanulate, more or less regular, with a capsule formed of about ten carpels (the stigmas having an opening in their centre), and being five or ten celled. In every case of these five terminal flowers it is the first instead of the last to open, so that the inflorescence is determinate as respects the terminal flower, whilst the other flowers, and they are fewer than usual, are developed normally, and show no indication of monstrosity. The terminal flower of the central stem is surrounded by a circular involucre of bracts or sepals (scarcely distinguishable from each other) of about twenty-one or more leaves in three whorls, or rather crowded spirals, reminding one of involucre of the *Compositæ*. The corolla is  $3\frac{1}{4}$  inches across, and is plaited and lobed, the petals forming it being more or less separated at their terminations, and one being attached outside by its sub-tubular base to the base of the corolla.

"The corolla has twenty-four lobes, with five petaline stamens growing upon it, eighteen perfect stamens—one abortive. The terminal flowers on the other stems are of the same kind, but formed of fewer parts and less plaited than the above, one being imperfectly united on two sides of the corolla."

We have seen similar instances before, but this is so well marked that it is worth depicting. We have also seen a variety in which the tube is greatly enlarged and somewhat like a *Gloxinia*.

#### MADRESFIELD COURT GRAPES.

Of black Grapes no more delicate variety can be grown than this, the risk being either at stoning or when swelling preparatory to colouring. Knowing its peculiarities, no Grape with me has such close attention. In the case stated by "A Hampshire Gardener," I am inclined to think that while fumigation did it no good, other causes were at work to produce the calamity. Foliage is no criterion just now, as this may be good and yet the Grapes be faulty. Had syringing been mentioned this might have put me on the track; still, if the house had been closed, and sun shining through on to the Grapes after fumigating, the evil would be done at once. Again, should the vinery be closed so that any condensed moisture settled on the berries with smoke the mischief would be done quickly. The skin of this variety is very susceptible to injury, as sun will affect this when all other varieties are safe in the same house. Late ventilating in bright weather would cause the injury. I have made front ventilation so that a little air is admitted constantly. Not having fumigated a vinery for some years I am unable to speak personally of its effects.—STEPHEN CASTLE, *West Lynn*.



#### ODONTOGLOSSUM CRISPUM.

THOUGH such large numbers of the *Odontoglossum* have been imported of recent years, and it might be expected that succeeding consignments would begin to contain a greater proportion of poor varieties, this does not seem to be the case, and the fact is the collectors have to push their way into fresh districts to obtain anything worth sending home. Some places have been thoroughly ransacked for years, and as each traveller has been anxious to obtain varieties distinguished by their size, good form, or rich markings, those who go in search of such plants now necessarily have to look very closely for them and extend their journeys. At first less care was exercised in the selection, there was a demand for all, and the better forms had not acquired such a distinctive value as they have now, consequently nearly every importation contained a large proportion of inferior varieties which would scarcely be allowed house room at the present time. Of course they are not all treasures now that are brought over for sale, as many, no doubt, are collected when not in flower. But some collectors have become noted for the high quality of their consignments with much advantage to the firms that have employed them. The best varieties of this favourite Orchid command high prices, but there are thousands of plants grown of good varieties, the flowers of which find their way to Covent Garden and the leading florists' shops in considerable quantities. We have recently seen a variety bought as a plant that had not flowered, and certainly if the dealer had seen it he would

not have parted with it for the very moderate sum demanded. The sepals and petals were broad, well proportioned; the latter slightly fringed at the margin and pure white, the upper sepal with a median line of purplish crimson and one central brown spot, the two lower sepals deeply stained with crimson, each with one central brown blotch. The lip was particularly neat, broad, slightly but evenly fringed, the crest bright yellow, a rich reddish-brown centre, a white margin dotted pale purple. Varieties like this have a very distinct appearance; they are more pleasing than the heavily spotted forms, and more effective than the pure white varieties. For buttonholes, one flower of a fine *Odontoglossum crispum* with a small *Adiantum* frond behind it is admirable.

#### ORCHID FLOWERS.

Mr. J. Cypher, Cheltenham, sends fresh bright flowers of the following—*Cattleya gigas Sanderiana*, one of the richest coloured forms we have seen, and there are many handsome *Cattleyas* of this time now in cultivation; the sepals and petals were deeply suffused with crimson, the lip of a marvellous rich magenta hue; *Cattleya Warneri*, very beautiful, a capital variety; *Odontoglossum crispum*, fine spotted variety, the flowers well formed; a good variety of *O. Pescatorei* and *Cattleya Gaskelliana*, from a plant with six fine white flowers.

#### BOLBOPHYLLUM BARBIGERUM.

The Burford Lodge Orchids at South Kensington last week formed a beautiful and much admired group, as not only were several of the plants valuable varieties or interesting curiosities, but they were all notable for their healthy condition, proving that they appreciate the treatment accorded them by Mr. Bickerstaffe. One of the most peculiar of what would be termed the botanical curiosities was *Bolbophyllum barbigerum*, which is illustrated in my treatise on Orchids, and specially described in the chapter devoted to a consideration of the characteristics of the labellum. Dr. Lindley has noticed the plant in the following manner:—"The lip is one of the most extraordinary organs known, even amongst orchidaceous plants. It is a long, narrow, flexuose, sharp-pointed body, closely covered with a yellow felt; just within its point is a deep purple beard of exceedingly fine hairs; on the under side, at a little distance from the point of the lip, is another such beard; and besides these there is, at the end of the lip, a brush, consisting of very long purple threads, so exceedingly delicate that the slightest disturbance of the air sets them in motion, when they wave gently to and fro, like a tuft of threads cut from a spider's web. Some are of the same thickness throughout, others terminate in an oblong club, so that when the hairs are waving in the air (and I do not know that they are ever entirely at rest) a part floats gracefully and slowly, while others are compelled by the weight of the glandular extremities to a more rapid oscillation. Nor is this all. The lip itself is articulated with the column by such a very slight joint that to breathe upon it is sufficient to produce a rocking movement so conspicuous and protracted that one is really tempted to believe that there must be something of an animal nature infused into this most unplant-like production."—L. C.

#### THOUGHTS ON CURRENT TOPICS.

It has been almost too hot to think lately, and as to writing I can scarcely understand anyone indulging in it as a pleasurable operation with the temperature between 80° and 90° in the shade. Even reading is irksome to the indolent, of which I fear I am one, and such individuals are apt to merely glance over the pages before them and wonder how it has been possible to fill them; still, the fact that they are filled shows that all men are not lazy, and all the more credit to those who labour when so many are naturally inclined to rest. And beyond doubt rest is well won by many whose lot is to toil the livelong day under a tropical sun, and then commence the tiring work of watering till the shades of evening invite them to repose.

I AM inclined to think there is no class of men who work so many hours' overtime as gardeners do—not for what they gain by it, for hundreds are never paid for this extra labour, nor do they expect a cash return. They are content if they can win success and approval, with a holiday now and then pleasantly granted at a convenient time. In my experience it is not those men who, in their probationary days, have rebelled against a little extra labour when circumstances demanded it, who have made the best headway in the world; and also I am equally convinced that those employers of men who are unreasonably exacting do not get the best served. During such weather as we have lately experienced many gardeners have had to work long and wearily, both before and after the stereotyped hours, and is it too much to hope and expect that consideration will be extended them when the strain is over, and that their wages may not be "stopped" during a few days' or a week's cessation from labour when this can be indulged without prejudice to the contents of the gardens in their charge? There are few things I like better to see and to think about



than gardeners winning by their zeal a claim to rest, and those for whom they labour recognising that zeal and claim, and granting facilities for the compensating holiday. Many do so, but not all; nor do all make good their claim for consideration.

WHEN I commence a series of erratic notes I never know where my thoughts will lead. They led me to say that writing was not tempting to the tired or the lazy, and reading somewhat of a task rather than a recreation in broiling summer weather; but I did read with attention and enjoyment the "Reminiscences of Fifty Years Ago," in the opening article of the issue of the 23rd ult. Not many persons could have evolved from their memory that most interesting historical review. It seems to have attracted attention beyond the community of gardeners, for I find in a daily paper a paragraph that was evidently inspired by the article in question. Very clever are expert newspaper paragraphists in garnishing ideas and placing them temptingly before the public, and the example referred to is worthy of reproduction. Here it is.

"EVOLUTION and advertising are two very incongruous subjects, but they come readily together in a retrospect of the last fifty years as regards horticulture. Fifty years is but an hour or a second in connection with evolution; but what marvellous changes have been effected by the skill of the horticulturist in that comparatively short time! The flowers we have now would scarcely be recognised by the old gardeners, so much have they been improved or altered. What, then, must be the result of fifty centuries of cultivation and trying what can be done? Fifty years ago the old firms of seedsmen and horticulturists considered it *inf a dig*. to advertise; but more enterprising rivals arose, took another course, and, by persistently telling the public what they had to sell, they gradually drove the old firms out of the market. We believe only one of the pre-Victorian 'large firms' in the seed trade still exists as a leading house; though some of those which have since risen to the top of the tree had an existence in a small way fifty years ago. Certain it is that the present leading firms have accomplished their elevation primarily by persistent advertising, and secondarily by supplying good articles; for it is no use keeping the latter unless you let the public know that you do keep them and can supply them. Fifty years, after all, tells much in favour of the evolution theory, and a great deal more about the advantages of advertising."

THAT paragraph was evidently founded on the article in question, and I have only one objection to it. I do not believe that any firm could become strong and really and lastingly great who made the supplying of good articles a "secondary" matter. An ephemeral success may be attained by "puffing," but public confidence can only be won by making the superiority of the article sold the first consideration; but it is palpable that the mere possession of such articles does not suffice to make a prosperous trade. The public must know of their existence and disposal, or they simply represent dead capital. And farther, experience proves that advertising to be profitable must be persistent and systematic. A full succession of crops can only be had in the garden by regular successional sowings of seed.

ANOTHER thought now arises. It has sprung spontaneously from the subject and was in no sense premeditated. It is that some would-be advertisers do not pay a great compliment to the discernment of readers to whom they appeal; and I am not quite sure that the editors of papers are to be altogether congratulated in encouraging a system, that appears to be growing, of vendors extolling their own wares under the guise of "news," for disguise it how they may the public can see the underlying motive, and a feeling of revulsion, rather than approval, is engendered. There is nothing like fair and square legitimate advertising in a genuine business manner for winning confidence, and it is by acting on that principle that every really great firm in the kingdom has made itself what it is to-day.

BUT I must go back to the "Reminiscences" mentioned, or rather to the comment on them by an "Old Gardener," on page 523. I claim to be an oldish member of the craft, but feel to be nowhere as regards long experience with the author of the historical review, which is the most complete of its kind of any I have seen. It is possible, too, that I may be younger than the "Old Gardener," who so ably supplements the notes in question, and may consequently appear a little presumptuous in venturing to dissent from one observation in the comment. With nearly everything said by an "Old Gardener" I agree, only my memory will not take me back for much more than forty years; and I believe we had quite as good Potatoes, Cauliflowers, Cabbages, Onions, Parsnips, Carrots, and Celery then as we have now. I gathered Peas forty years ago quite as early in the season as I have done since, but we have finer later sorts now.

In the far past time we had, apart from the Early May, the Charltons, Seimetar, Bedman's Imperial, and the best of all the lates, the British Queen; and it is not bad yet. But we had no Champion of England, Ne Plus Ultra, Veitch's Perfection, Telegraph, Telephone, and a number of others now in cultivation, therefore I am bound to conclude a great advance has been made in Peas. We had Ashleaf Potatoes just as good then as we have now, and just as good now as we had then; but I am not certain that the same can be said in respect to any other variety. But I had, perhaps, better not dwell on that subject, or friends Iggulden and Abbey may—well, not give me their generous support.

THE remark of "An Old Gardener," in which I cannot quite coincide, or rather with two words in it, is this—"There is not much gain in the quality of fruits, if any." The qualifying words "if any" implies there has been no gain. I think, on the contrary, the gain has been very decided, but am open to correction. I have no time to hunt up records on the point, and may possibly be led a little astray by faulty memory, and we have it on a great polemical authority that this is excusable.

IN considering old and new fruits let us take Grapes. The two best in existence, the Black Hamburg and Muscat of Alexandria, were grown half a century ago; so were the Frontignans, but these latter delicious little Grapes appear to have gone out of fashion. But previous to Her Majesty's reign we had, I think, no Black Alicantes, no Gros Guillaumes, no Foster's Seedlings, no Mrs. Pince's, no Madresfield Courts, no Duke of Buccleuchs, no Gros Marocs, no Gros Colmans, and others might be indicated that were not known in 1837, but sufficient are named to show that there has been advance in Grapes, and I cannot help thinking a very great advance.

Now let us go outside. Apples.—I know we had good sorts over forty years ago; indeed, I never remember better than the red-checked "Summerings," the old Ribstons, the Wyken Pippins, and some others; but possibly their quality was enhanced by the circumstances of the case, for we often incurred some risk in gathering them, for the simple reason they were not exactly our own property before they were in possession; but I remember no Cox's Orange Pippins or Pomonas, no Lord Suffields, no Duchess of Oldenburgs, no Prince Alberts, no Ecklinvilles, no Stirling Castles, no Lord Derbys, no Lady Hennikers, no Lord Grosvenors, no Mr. Gladstones, unless the old "Summering" was identical, for we know that "grand old" sorts do sometimes get new names. But the subject as regards Apples need not be pursued, as I think enough has been said, if no mistake has been made, to show that there has been a little gain in this important fruit.

PEARS.—Names crowd on me which I had not seen forty years ago. Here are a few—The Royal Pears of Mr. Huyshe, Prince Consort, Prince of Wales, Princess of Wales and Victoria. Beurrés Giffard, Harly, de l'Assomption, Superfin; Doyenné du Comice, Souvenir du Congrès, Marechal de Cour, Marie Benoist, Madame Treyve, and Ollivier de Serres. We have thus the additions of early and late Pears, and all of the best. Numbers might possibly be enumerated that have been brought into cultivation during the past fifty years if anyone were disposed to search into the matter.

PLUMS.—I think there has been a useful gain in Plums during the period in question. The most generally productive and servicable of all Plums, Denyer's Victoria, whenever and wherever it may have been raised, has certainly come into cultivation during Victoria's reign. The season of Plums has been extended too by the Messrs. Rivers, father and son, the former giving us the Early Prolific, the latter the Grand Duke. From the same source also comes the Czar, that has met with much acceptance by growers of fruit for market, and the demand for trees is, I believe, constantly increasing; indeed, I think that is the case with all the varieties named, so that there seems to have been a gain in Plums.

So there has in Cherries, Peaches, and Nectarines; but a long time elapses before new fruits get widely circulated and generally known. Early Rivers, Governor Wood, Monstreuse de Mezel, Reine Hortense, Bigarrean Noir de Schmidt have been added to Cherries in my time—at least I think so, but may be wrong as regards Governor Wood. Peaches have increased in numbers and in varieties that cultivators would not like to be without, especially the early American and Sawbridgworthcans—of the former Alexander, Waterloo, and Hale's Early; of the latter Early Rivers, Alfred, Beatrice, and Louise; then of late sorts we have Goshawk, Sea Eagle, Magdala, and Gladstone, some or all of which have probably a long future before them. As to Nectarines, it will not be far from the truth to say that Rivers has revolutionised them. When Her Majesty ascended the throne there was no such large and rich fruits as are now produced under the names of Pineapple, Rivers' Orange, Lord Napier, Victoria, Stanwick Elruge, Albert Victor, Humboldt, Milton, Newton, and Spencer. The "gain" is enormous, as I am sure must be admitted on reflection.

IN small fruits additions have been made that are worthy of recognition. In Strawberries I have no recollection of gathering Vicomtesse Hericart de Thury, Dr. Hogg, President, Sir Joseph Paxton, Marguerite, or Empress Eugenie even thirty years ago; and I suspect that no half-dozen that were grown in 1837 can be found to equal those named. In Raspberries we have gains in Prolific and Prince of Wales; in Black Currants, Lee's Prolific; in Reds, Victoria; in Gooseberries—well the additions are so numerous that I had perhaps better let them alone, or the Editor will be playing old gooseberry with me, on the ground that he has more than enough at once of the jottings of—A THINKER.

#### ROSE-GROWING FOR BEGINNERS.

MR. GILMOUR has now, I presume, completed his useful and interesting articles on "Rose-Growing for Beginners." Now please allow him to collect them into a neat little volume, and command him pre-emptorily to publish it, when I feel sure it will meet with a ready sale.

As soon as Bank Holiday in August is past, and Rose shows over,

all rosarians will be purchasing it next season, mixing compost, chopping turf, and making new borders where needed to be planted in October and November.

No book would be more useful for a beginner, and every old hand at Rose growing and showing might find advice and hints to improve his method of culture. Though I have been at Rose-growing near forty years I will promise to take a copy, and advise all my friends to do the same, simply because I am in the matter of Rose growing, Rose showing, Rose loving—FANATICUS EGO.

[We grant the allowance; a "command", perhaps may not be necessary.]



We have received a printed protest signed by twelve seed firms against some statements respecting the ENGLISH RETAIL SEED TRADE AND SUNDAY POSTAL LABOUR, which Mr. Martin J. Sutton was reported by the *Times* to have recently made before the Select Committee of the House of Commons. It is right to state that Mr. Sutton was the first to point out to us the inaccuracy of that report, which did not appear in our columns. The note we published on page 513 was inserted as a correct version of Mr. Sutton's evidence, to which the protest referred to has obviously no application. We may add, however, that the firms who desire to state they do not receive letters and despatch goods on Sundays are Messrs. Barr & Son, London; James Carter & Co., London; Drummond & Son, Dublin; Drummond & Son, Stirling; Daniels Bros., Norwich; Charles Fidler, Reading; Harrison & Son, Leicester; Hooper & Co., London; Kent & Brydon, Darlington; Lamoureux & Co., Plymouth; Little and Ballantyne, Carlisle; Oakshott & Millard, Reading.

— BEGONIAS AND ANNUALS AT SOUTH KENSINGTON.—We understand that Messrs. John Laing & Co., Stanstead Park Nurseries, Forest Hill, intend making a large display of double and single flowering Begonias at the Royal Horticultural Society's meeting on July 12th; and Messrs. Carter & Co., High Holborn, a large display of annuals in pots.

— A VERY LIGHT SHOWER fell in the neighbourhood of the metropolis early on Tuesday morning, but it was scarcely sufficient to lay the dust. It is the first rain that has fallen since June 3rd, and a heavy downpour is much needed by languishing crops. The air, however, is cooler, and in that respect the change is highly acceptable.

— THE NEWCASTLE-UNDER-LYME ROSE AND HORTICULTURAL SOCIETY will hold their third Exhibition in the Stubbs Walks, Newcastle (Staffs) on Monday, August 8th, this year. Fifty-five classes are enumerated in the schedule, sixteen being devoted to Roses, the prizes ranging from £3 to 1s. First, second, and third, and in some cases fourth prizes are offered. The other classes are for plants, fruit, and vegetables, the prizes mostly of small amount. The Hon. Secretary is Mr. W. H. Ramm, Sutherland Chambers, Newcastle.

— THE fifteenth annual exhibition of the WIMBLEDON ROYAL HORTICULTURAL SOCIETY'S SHOW, held on the 6th inst., was one of the best the Society has had. The entries were very numerous, competition brisk in many classes, and produce good. We are not able to insert a report of the Show this week.

— STRAWBERRY FETE AT CHISWICK.—In answer to our inquiry on the subject we are authorised to state that Fellows of the Royal Horticultural Society have the privilege of introducing eight friends by written order on that occasion, or any ordinary day. As has been previously intimated, the Fête takes place on Saturday next.

— MR. J. C. ARNALL, Headington Hall, Oxford, writes:—"I shall feel much obliged if any of your readers will kindly inform me where I can get a small packet of seed of *Digitalis Mariana* (the Sierra Morena Foxglove), and *Digitalis Thapsi* (the Mullein-like Foxglove). I only want about six plants of each for hybridising."

— LAST Thursday (June 30th) was a grand day at the CRYSTAL PALACE, SYDENHAM, when it was visited by the Prince and Princess of Wales, with the Crown Prince and Princess of Germany and a large party of distinguished persons. The floral decorations in the Royal

dining-room were simple but tasteful, consisting chiefly of *Maréchal Niel* and *Safrano* Roses placed with their own foliage and Fern fronds on the cloth. In the centre were small vases filled with *Odontoglossum vexillarium* and *O. crispum*, the former having a most delicate appearance. The decoration of the Royal boxes was conducted by Mr. W. G. Head, and an excellent effect was produced by narrow marginal borders of Roses in variety, *Anthurium Schertzerianum*, *Gloxinias*, and Ferns; the divisional lines on the staircases being formed of Ferns, Palms, and *Caladiums*. Two bouquets were prepared for presentation to the Princesses, and consisted in one case of light and dark Roses, *Bouvardia longiflora*, *Odontoglossum crispum*, and *Cattleyas*, in the other of yellow and pink Roses with *Stephanotis*. In the evening the grounds were illuminated in an exceptionally beautiful manner by some thousands of the Vauxhall lamps.

— MAHONIA AQUIFOLIUM.—A correspondent, "Curious," desires to ask if any reader of this Journal could oblige him with a receipt for making wine from the fruit of *Mahonia Aquifolium*.

— NEW PUBLIC PARK, BILSTON.—Mr. William Hall of Bilston, having generously presented the town with 22 acres of ground within ten minutes' walk of the Bilston Town Hall as a Jubilee gift for a public park, it was decided to offer two prizes of twenty and ten guineas for the best design for laying out the same. The first prize has been awarded to Messrs. W. Birron & Son of Elvaston Nurseries, Borrowash, Derby, and the second to Mr. W. Milner, Crystal Palace School of Landscape Gardening, Sydenham.

— "X." sends the following note:—"At the Richmond Show (Surrey) last week the TABLE DECORATIONS were not quite so good as usual, but considerable discussion was caused by what was generally regarded as a strange error of judgment on the part of the censors in that class. Mr. J. R. Chard, Stoke Newington, and Mr. Goodwin, Twickenham, were the principal exhibitors, and though Mr. Chard was placed second, his table was preferred by many persons. In the first prize table Iceland Poppies were freely employed, but they were arranged with other flowers too thickly, and constituted an almost impenetrable screen for persons facing the vases. The fruit also were very formally arranged. Mr. Chard's arrangement was in his customary light graceful style, perhaps not finished with so much care as generally characterises his work, but admittedly superior in most points to that placed first. The Judges spent considerable time over the class, and had ultimately to call in a referee, but it was a case that would have well deserved the attention of the Committee, if it were not for their rule that the Judge's decision is final. The undue interference of committees with the judges' awards or the encouragement of protests is not desirable, but instances like this sometimes occur, when a further appeal would be advantageous."

— GARDENING APPOINTMENT.—Mr. William Suart, late foreman at Hartsholme Hall, near Lincoln, has been appointed head gardener to Lord Monson, Burton Hall, near Lincoln.

— "AMATEUR" writes:—"I have a row of PAULINE STRAWBERRY this year, which in several points is giving me much satisfaction. It is early, productive, and the fruits come of a good size, their distinct appearance rendering them attractive as a dish on the table. In flavour it is not quite so good as might be desired, but this may be owing in some degree to the unusually dry weather, as several other varieties are not up to their usual standard this season."

— A MEETING of the members of the WAKFIELD PAXTON SOCIETY was recently held at Councillor Lupton's, the Saw Hotel. Councillor Milnes presided, and Mr. H. Oxley was in the vice-chair. Some of the members of the party who visited Studley Royal, the seat of the Marquis of Ripon, gave an interesting report with regard to their excursion. On the motion of Mr. Herbert Chapman, seconded by Mr. John Fletcher, a hearty vote of thanks was accorded to Mr. Tom Mason, of Fountains Hall, steward to the Marquis, and also to Mr. Clarke, the head gardener, for their kindness and courtesy to the visitors, who were permitted to visit the gardens and to look over the house, museum, &c. There was no essay read at the meeting last Saturday evening, but a long and interesting discussion took place on the *Pyrethrum*, the *Pansy*, the *Viola*, and other early summer flowers, of which there was an exceedingly good display on view. Mr. T. Garnett, head gardener to Miss Edith G. Mackie, opened the discussion with some very interesting details with regard to the growth of *Pyrethrums* and *Pansies*. Alderman

W. H. Lee proposed a vote of thanks to Mr. Garnett for opening the interesting discussion, and to the exhibitors of flowers. Mr. T. Senior seconded the motion, and said they were much indebted to Mr. Garnett for the great interest he had taken in the Society since its formation, and for the ability he displayed in reference to all horticultural matters. Mr. T. R. Preston supported the motion, as did also Mr. H. Oxley. The last named gentleman remarked that formerly market gardening was extensively carried on at the Adel Reformatory, but on visiting it that day he found that the cultivation of flowers had taken the place of growing vegetables, and he saw no less than 7000 Rose trees and large beds of flowers of various kinds, for which there was a great demand. He had no doubt that the present great love for flowers had been brought about in some measure through the influence of such societies as the Paxton Society.

— THE GRASSHOPPER PLAGUE is giving serious trouble in Algeria this year. The efforts made to destroy the eggs have proved useless. In one district 50,000 gallons have been collected and burned. This represents the destruction of 7,250,000,000 insects.

— WE are informed by MESSRS. SUTTON & SONS of Reading, that the statement which appeared in our columns last week, to the effect that they "provided a substantial repast for 2000 aged persons," is incorrect. They only placed two of their large rooms at the disposal of the Jubilee Committee, who provided the dinner.

— MESSRS. STORRIE & STORRIE, of Dundee send us samples of a new LABEL REST. It is an ingenious yet simple arrangement of galvanised wire, in which a label horizontally placed is tightly gripped and held at an angle convenient for reading, the wire being twisted below the label and made to form two legs for inserting in the ground. These labels, we are informed, have been in use for two years by the patentees, and have given such great satisfaction as to justify them in offering them to the public. They are durable, portable, and useful for flowers and trees in gardens.

— CROYDON FLOWER SHOW.—A correspondent informs us that a very successful and largely attended show was held at Croydon last week. The most successful winners in the plant classes were Mr. W. King, gardener to P. Crowley, Esq., and Mr. T. N. Penfold, gardener to Rev. Canon Bridges. The last named exhibitor also staged fruit and Roses successfully, and Mr. Jupp, gardener to Cuthbert Johnson, Esq., secured the Society's and Messrs. Sutton's prizes for excellent vegetables. There was a great display of Roses, but the blooms were rather small. Messrs. B. R. Caut, F. Cant, G. Bunyard, G. W. Piper, and Cheal & Sons were prizewinners, as also were, in other classes, Revs. R. C. Hales and Alan Cheales, with Mrs. Waterlow and Messrs. T. B. Heywood, A. Slaughter, E. R. Linsdell, J. Macdonald Smith, E. Mawley, W. J. Dart, W. E. West, and M. Hodgson. The National Rose Society's medal offered for the best Rose in the Show was won by Miss Baker with Catherine Mermet. Messrs. J. R. Box, J. Laing & Co., and J. Cheal and Sons contributed to the attractiveness of the Show by their special exhibits.

— MR. ROBERT SYDENHAM of Birmingham, in describing in a small manual how he came to GROW BULBS, states:—"When I first went specially to Holland to see why the Dutchmen were able to grow bulbs better than they can be grown in any other country, I quite realised when there the secret of their success. The land is all perfectly flat, the soil is nothing but fine sand, such as seen by the seaside, which is always about one even moistness, for about 18 to 24 inches under the surface is always water, consequently, however dry the weather is, the moisture drawn up from the water always keeps the bulbs in one even state of moisture, as the soil is never dry 3 inches under the surface. As a proof of this, I am told the Dutch can plant young Lettuce out in the hottest weather, and the plants will hardly feel the shift after the first night. Should heavy rain ever fall it drains through the sand immediately. The Dutch always cover their bulb beds over during the winter with straw or reeds about 4 inches thick to keep out the frost, and they tell me the great secret of success is to keep the bulbs in an even temperature and away from the frost. The land where the bulbs are grown is very richly manured with cow manure every second or third year, the ground being covered with manure 6 or 8 inches thick. There is such a demand for cow manure in the bulb districts that it is brought from all parts of Holland, and constitutes quite a trade; in fact, many dairymen make nearly as much out of their cows' manure as they do

out of the milk. Hyacinths are only grown in the same ground once in three years, then a crop of Tulips or Crocus, the third year often standing idle."

## DOUBLE FLOWERED IVY-LEAF PELARGONIUMS.

THIS section of the Pelargonium has been improved very much during the last few years by Mr. Cannell and others. They can be grown into any shape and to a great size within a space of twelve or fifteen months. I lately saw several well flowered plants at Northerwood, Lord Londesborough's beautiful place near Lyndhurst. They were trained to a pyramidal-shaped trellis, about 5 feet high, and 3 feet through at the pot. These Pelargoniums are also very useful for draping a pillar or a wall in the conservatory or greenhouse. Small plants grown in 32-size pots, having five thin sticks round the edge of the pots, with an inclination to the centre of the ball, and the tops brought together and tied to a short stick placed upright in the centre of the pot and the shoots trained loosely thereto, make very useful and effective plants for standing in vases on the dinner table and for other decorative purposes.

Veritable pyramids of dark scarlet, pink, rose, white, &c., from 5 to 6 feet high, and from 3 to 4 feet through at the base, may be grown in a 12 or 16-inch pot within a period of two or three years from cuttings, provided the plants are potted in a compost consisting of three parts of sound fibry loam and one of pulverised horse droppings and sweet leaf mould, with a liberal sprinkling of coarse sand added. Any young plants which are destined to be grown into large specimens should not be placed on a trellis until they are shifted into their flowering pots, as many of the shoots would be sure to get broken in the process of uncoiling, but, instead, support the shoots by tying them to upright sticks in the meantime. Strong galvanised wire, painted green, is the best material to make the trellises with for ordinary sized specimens, but for large specimens the framework of the trellis should consist of quarter-inch thick iron, with rings of stout galvanised wire.

In training the plants, commencing, as a matter of course, at the bottom, coiling the shoots round the trellis until the top is reached, and the whole is completely covered with short-jointed shoots. If the object be to secure large specimens in as short a time as possible all flowers should be picked off as soon as they appear, and alternate waterings of weak liquid manure and clear water be given at the roots when considered necessary.

The double-flowered Ivy-leaf Pelargonium is also a capital basket plant, the flowering shoots hanging gracefully over the edge of wire baskets suspended from the roof of greenhouse or conservatory being very effective. Small flowering plants in 48 pots are good for drooping over the edge of the side and central stages in greenhouse and conservatory. It is also a first-rate plant for planting in rustic vases in the pleasure grounds, in which, likewise, large pyramids of the various distinct flowered varieties may be formed during summer by the use of enriched loam, moss, and small plants. The interior of the pyramids may be formed by the mould, working the moss round the outside, and putting in a plant here and there as the work proceeds, giving sufficient water through a rose to settle the soil about the roots, and the moss several times during the progress of the pyramids, on the completion of which the Pelargonium shoots should be pegged loosely into the moss. In the absence of rain the floral pyramids should be watered through a moderately fine rose every afternoon. As the above remarks are in reference to rooted plants, I may here say that cuttings of the most approved varieties taken at once, or, indeed, any time between February and October, and inserted in 3-inch pots filled with sandy soil in a close moist frame or propagating house, will soon root. They should then be potted singly, watered, and grown near the glass; afterwards shift the plants into larger pots as they require more room at the roots, using the loam in a rougher state at each potting. The plants, I find, make satisfactory progress and flower freely during the winter and spring months in a light house and in a temperature ranging between 45° and 50° at night and between 50° and 60° in the daytime.

In the following list are included a few of the best varieties to grow for any of the purposes indicated:—Madame Thibaut, deep pink; Isadore Feral, flowers large and very double, of a most pleasing shade of light rose colour; Louis Thibaut, deep red, of fine shape; Jeanne d'Arc, one of the best varieties, white, suffused with light lavender; Comtesse Horace de Choiseul, beautiful satiny rose, shaded towards the edge of petals white; Abel Carrière, of a beautiful soft magenta colour, feathered margin in upper petals; A. F. Barron, lilac rose flowers, large and very full; De Brazza, lively salmon, full pips of perfect shape, short jointed and free; Gloire d'Orleans, rich crimson magenta, produced in great abundance, trusses and flowers medium size, of dwarf habit, consequently not



suitable for growing into large specimens; Candeur, flowers very double, pure white, vigorous habit, and very free; Congo, of fine form and substance, light lilac, shot deeper, centre rose, edges silvery white; Hanoi, reddish salmon, of a pleasing colour, fine pips and trusses; and La Florifère, soft rose pink, a most suitable variety for baskets and vases.—H. W. WARD, Longford Castle.

### LILACS.

IN shrubberies Lilaes are invaluable, while few plants are so common or so generally appreciated in suburban gardens as the ordinary forms of *Syringa vulgaris* and *S. persica*. Quite a large trade has also sprung up in forced flowers early in the year, and small plants in pots are also much valued for decorative purposes, grouping either in the conservatory, rooms or corridors. Small standards are most useful for such purposes, and the variety Charles X. is especially adapted for them, with clear stems 1 to 2 feet high, and neat bushy heads. The variety named is compact in growth, flowers freely and early, and therefore forces well. For culture in pots several varieties have been introduced of recent years, mainly from the continent, but for general planting out of doors few have paid much attention to any but the ordinary old forms that have been grown for so many years. One handsome variety of recent introduction was brought to our notice a few weeks since by Messrs. Wm. Paul & Son, Cheshunt—namely, Marie Lequay, of which two trusses are shown of their natural size in fig. 2. The flowers are pure white, of great size and substance, the lobes long and oval in form, the panicles dense compact conical trusses, and the fragrance powerful. It is one of the *S. vulgaris* varieties, and would make a grand addition to any shrubbery.

A selection of the best from a continental collection of sixty varieties was given some time ago in these pages and comprised the following:—Dr. Lindley, massive trusses of purplish lilac flowers; Alba grandiflora, splendid spikes of pure waxy blooms; Gloire de Moulins, very free, dark, and effective; Goliath, immense trusses of dark lilac flowers; Due d'Orleans, soft rose colour, late, distinct, and attractive; Sehweelavina, silvery blush; Verschaffelti, pale lilac, bold trusses; Rubra insignis, dark lilac, massive heads; Gloire de Coureelles, very large, medium colour, late; Madame Briot, lilac deepening to violet, the darkest of all; Hyacinthiflora, a distinct and beautiful variety with fine spikes and symmetrical double flowers; and azurea plena, double, free and effective.

### CHOICE HARDY PLANTS IN FLOWER.

AT this season of the year choice hardy flowering perennials are somewhat numerous, and as it is a good time for making selections for future planting, I will briefly note some of the most useful from a large and representative collection.

#### SPANISH IRISES.

For the middle of June to the middle of July it would be difficult to conceive a group more lovely and so extremely varied as the Spanish Irises. Though somewhat late this season, they are not devoid of any of the charms which always attend their flowering. So characteristic of Orchid beauty are they in general aspect, that they would command far greater attention were they the inhabitants of some tropical clime. Quite recently in conversation with an Orchid fancier I pointed to the beauty and purity of that unequalled English Iris, Mont Blanc, as white as driven snow, and as he looked upon it with admiration he wondered whether "he was more fond of Orchids than the genus Iris." If the Spanish Irises were more generally known who could fail to admire them? and I am sure a far greater number would grow them than now. It is not strange that many Orchid growers are much in love with this family, for in them they see much of that extreme beauty and grace which marks the flowers of their choice, and but for these Irises would hold a unique position in the floricultural world. These Irises are extremely hardy, are easily established, and increase with remarkable freedom. They are at home in the herbaceous or rockery border, and prefer a dry and rather sunny position. A moderately rich soil will suit them well, and once planted they will annually increase in beauty, and may be left at least five or six years undisturbed. September and October are the best months for planting them, and not more than 4 inches below the surface, using plenty of sharp sandy grit about the bulbs. In point of colour they are very much varied, and in a good collection pure whites, creams, and shades of sulphur, lemon, canary, and rich golden and orange yellows, celestial and lavender blues, together with golden and bronzy hues interspersed, will all be found, as well as many intermediate and varying shades of each. For cutting they are simply unique, and will vie with the choicest floral gems of the day, while not the least important particular respecting them is their lovely and welcome fragrance. Such, then, is a brief, though very inadequate, idea of one of the most useful groups among hardy bulbs.

### LILIUMS.

The season of Liliams has now commenced, and many fine species and forms are in full beauty. First on the list comes *L. pyrenaicum*, a yellow Turk's-cap, very hardy and free flowering. It is freely spotted with black; it attains 3 feet high when established, and increases readily without assistance. *L. pyrenaicum rubrum* grows somewhat taller, and has flowers of a bright orange red; it is a most pleasing and effective Lily. It is sometimes erroneously sold as pomponium, from which it is distinct. The true *L. pomponium* is also splendidly in flower; it is quite distinct in foliage from the preceding, and besides has fiery scarlet flowers. A noble Lily at this period, and one which cannot be too extensively employed. It grows 3 feet high or more, and succeeds well in ordinary well enriched soil. It is a native of southern Europe, and always admired when seen in flower. When fully established it forms one of the most striking objects in the whole of this extensive and exceedingly rich genus of plants. But by far the most noble and princely among early Liliams is that known as *L. monadelphum Szovitzianum*, for it stands without a rival. It is a Lily of great beauty, possessing much of the grandeur so characteristic of its race, while its fragrant handsome flowers tell their own tale. The cultural requirements are very simple, a rich loamy and rather sandy soil being all that it needs. In this, if left undisturbed, it will thrive for years, all that is requisite being occasional waterings with weak liquid manure during hot weather. No plant more noble or imposing can possibly adorn the higher portions of the rock garden in a partially shaded position in a deep rich soil than this; in fact, it improves by being lifted up slightly on account of its lovely pendent blossoms. These, it may be remarked, are more or less spotted with black, and vary in colour from pale primrose to deep golden, scarcely any two bulbs producing flowers of a similar shade. The flowers are recurved in a remarkable manner, and are borne on stout stems about 4 feet high. It is not unusual for large well established clumps of this magnificent Lily to produce spikes of eighteen to twenty of its lovely flowers.

Another Lily which has become a rarity of late years is *L. Martagon album*; it is still somewhat scarce, and is only another instance of the riches of this genus. It is a very distinct plant, producing quite a pyramid of its pure white wax-like flowers. It is perfectly at home in sandy loam, a soil which by the way suits so many Lilies, and even those which are reputedly peat lovers will, with care and discretion, succeed in it. I find cow manure on our light soils suit the majority of this genus, for even *pardalinum* and *superbum*, both recognised peat and moisture-loving plants, quite surpassed my expectations both as regards the height they attained and also the progress they had made below when lifted last season; in fact, I regarded it as highly successful, considering our very dry summer, and the fact that the plants were fully exposed to the sun. The other Lilies in the month of June are the forms of *L. Davuricum*, among which *L. D. erectum* is conspicuous. But I must not omit the lovely little *L. tenuifolium*, with its fiery scarlet flowers; these are very similar to pomponium in point of colour, of which it may also be regarded as a miniature. It grows a foot to 18 inches high, and delights in moist sandy peat. Its general aspect is fragile, and it should be regarded as one of the most slender gems of this valuable group of plants.

#### THE DOUBLE SCARLET GEUM.

*Geum coccineum fl.-pl.*—This is one of the most profuse of early summer flowering perennials, the colour vivid scarlet on spikes nearly 2 feet high; it is a most serviceable border plant.

#### POPPIES.

*Papaver orientale* and varieties.—For producing a dazzling display of brilliant crimson, scarlet, and orange flowers nothing can equal these Eastern Poppies. Perfect giants in their way, having gorgeously coloured flowers nearly equal in size to an ordinary dinner plate, and which in the case of many have a huge black blotch at the base of each petal, these plants are suited for large gardens when they may be viewed at a little distance, for it is not too much to say of them that they are overwhelming when seen in quantity and close to the eye. Some of the varieties grow to 4 feet in height, while there are others which only attain to about half that height. Very distinct indeed from them are the forms of *Papaver nudicaule* in their simple beauty and only a foot high, with their varying colours of white, orange, and yellow. Perfect gems for the rockwork are these, where they flower in great profusion for a considerable time.—J. H. E.

#### PROPAGATING DRACÆNAS.

SUCH useful and effective varieties as *D. gracilis*, *D. Goldiana*, *D. Lindenii*, and others of similar habit that have become too tall for ordinary decorative purposes, may have their tops taken off and rooted. This can be accomplished without the loss of a single leaf, provided they are cut where the wood is not too hard. When cut through where the wood is moderately firm only they root quickly and retain the whole of their foliage, which is not the case when the base of the cutting is hard. Each head if large should be inserted in a 5-inch pot, properly drained, and filled with a compost of loam and peat in equal proportions, with a liberal dash of sand added. Place a good pinch of sand in the centre for the base of the head to rest upon. Give a good watering, and plunge the pots in cocoa-nut fibre or other material, covering the rim of the pot and surface of the soil, and then keep them close under large bell-glasses or handlights. Shade from the sun. Other varieties, such as

*D. Cooperi* and *D. terminalis*, do not root so certainly without losing their leaves when the heads are cut and inserted. If these are taken they should not be confined in the propagating frame or under hand-lights unless the lights are tilted to prevent the foliage damping, an evil

slower, but no less certain method of ringing them and binding the stem above with moss. If the stem is well cut in the first instance, the plant shaded afterwards, and the moss kept moist, roots at this period of the year will be quickly emitted from the stem, when more moss or lumps of



FIG. 2.—LILAC MARIE LEQUAY.

which is very apt to occur. The greatest success can be attained by inserting them, and then plunging the pots in a shaded house where the atmosphere is close and moist; the leaves do not damp under these conditions. Those unfamiliar with the process of cutting the heads and rooting them according to the directions given may follow the older,

peat may be added, and finally the top taken. When they are first taken off the heads should be treated for ten days or a fortnight the same as advised above for rooting heads, by which time they will be established in their pots, and may occupy a position with the general stock. Pot young plants as they need more root space. *Dracenas* grow rapidly: if



shaded from the sun and given a high moist temperature. Be careful not to overwater these plants after they are first potted. More plants are brought into a stunted condition through this than any other cause.—B. W.

## ROSE SHOWS.

### NATIONAL ROSE SOCIETY.

METROPOLITAN SHOW.—JULY 5TH.

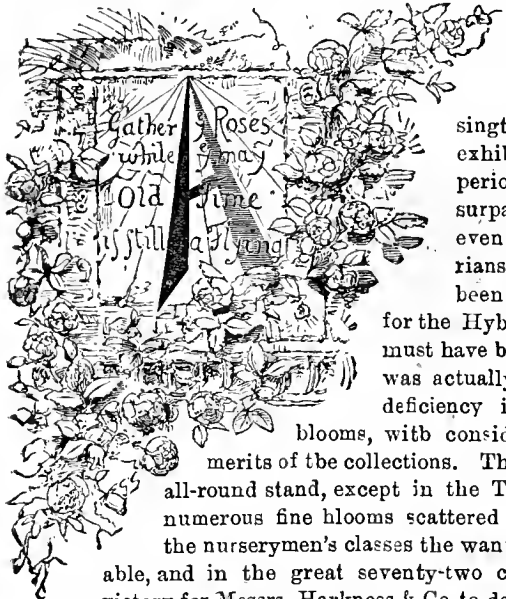

GAIN the great annual tournament of Roses has been held at South Kensington, and though intending exhibitors have had an anxious period lately the gathering far surpassed the expectations of even the most sanguine rosarians. The season has, however, been an exceptionally trying one for the Hybrid Perpetuals, so that all must have been prepared to find, what was actually the case—namely, much deficiency in size and substance of blooms, with considerable irregularity in the merits of the collections. There was scarcely one good all-round stand, except in the Tea classes, but there were numerous fine blooms scattered throughout the Show. In the nurserymen's classes the want of size was most noticeable, and in the great seventy-two class it was a remarkable victory for Messrs. Harkness & Co. to defeat the champion southern trade grower at the leading southern show. Yorkshire rosarians have reason to be proud of their representative. Most of the winning stands were, however, below the standard of previous years, except the Teas, which were in grand force, fresh, fine, and beautiful, quite refreshing in their purity, and amply proving how much they enjoy a tropical summer.

It was somewhat curious that the same Hybrid Perpetual and Tea varieties should gain the silver medals in the nurserymen's and amateurs' classes, Ulrich Brunner being selected amongst the former, and Comtesse de Nadaillac amongst the latter, both varieties being shown capitally in a number of other stands. There was nothing special amongst new Roses, and there was no entry for the gold medal, but the classes provided for old garden Roses, buttonhole and Moss Roses were very interesting, and attracted much admiration from the visitors.

In the conservatory there were four rows of boxes, the whole length on central and side tables, while a great portion of the eastern quadrant was occupied with the classes from 20 to 38. All the arrangements were well made, the judging was expeditiously performed, and the prize cards promptly affixed, but there was not a very large attendance of visitors.

#### NURSEYMEN'S CLASSES.

Class 1, for seventy-two varieties. A beautifully fresh collection from Messrs. Harkness & Sons, Bedale, Yorks, secured the premier award in this important class. In size they were wanting, but for freshness and clearness of hue they were excellent. The varieties were as follows:—Reynolds Hole, very fine; Madame Willermoz, M. Alfred Dumesnil, Madame Gabriel Luizet, Général Jacqueminot, Princess Beatrice, Anguste Rigotard, Captain Christy, Ulrich Brunner, Madame Therese Levet, Dr. Sewell, Marquise de Castellane, Jean Ducher, François Michelin, Horace Vernet, M. Noman, La France, Constantin Fretiakoff, Queen of Queens, Etienne Levet (beautiful), Lady Mary Fitzwilliam, Duke of Edinburgh, Heinrich Schultheis, La Rosière, Reine du Midi (?), Rosieriste Jacobs, Madame de Watteville, Sir G. Wolsley, Comtesse de Nadaillac, Duke of Connaught, Marie Van Houtte, Comtesse d'Oxford, Violette Bouyer, Star of Waltham, Catherine Mermet, Marie Banmann, fine; Pride of Waltham, Beauty of Waltham, good; Madame Montel, Antoine Ducher, Therese Levet, Merveille de Lyon, Le Havre, Niphotos, Dupuy Jamain, Souvenir d'Elise Vardon, A. K. Williams, Duchesse de Vallombrosa, Charles Lefebvre, Edith Giffard, May Quennell, M. E. Y. Teas, Madame Cusin, grand; Innocente Pirola, Sultan of Zanzibar, fine; Souvenir d'un Ami, Hippolyte Jamain, Duchesse de Morny, Maréchal Niel, Prince Arthur, Princess of Wales, Alfred Colomb, Royal Standard, Souvenir de Paul Neyron, Magna Charta, William Warden, Duke of Teck, Marie Finger, Fisher Holmes, Gloire de Dijon, and Madame E. Verdier. Mr. B. R. Cant of Colchester had a good stand, his blooms being of fair size and many in fine condition; some, however, lacked freshness, Her Majesty was very good, as were Madame Hippolyte Jamain, Madame Ducher, and Dupuy Jamain. The third prize went to Mr. Frank Cant, Colchester; and the fourth to Messrs. Paul & Son, The Old Nurseries, Cheshunt. Five collections were staged.

Class 2, forty-eight distinct varieties, three trusses of each. There were three stands in competition in this class, Mr. B. R. Cant improving on his previous essay by securing the first prize. He showed the following varieties:—Merveille de Lyon, Nardy Frères, Baronne de Rothschild, Madame Cusin, Maréchal Niel, Annie Laxton, Niphotos, François Michelin, Madame Lacharme, Marie Baumann, M. Noman, Duchesse de Vallombrosa, Marguerite de St. Amand, Madame Ducher, Madame Caroline Kuster,

Alfred Colomb, Souvenir d'un Ami, Souvenir de M. Boll, Madame Eugene Verdier, Marchioness of Exeter, Her Majesty, Ulrich Brunner, Madame Gabriel Luizet, Dupuy Jamain, Madame Prosper Laugier, Comtesse de Nadaillac, Madame Marie Verdier, Souvenir d'Elise Vardon, Etienne Levet, Madame de Watteville, Xavier Olibo, Catherine Mermet, Star of Waltham, Etoile de Lyon, Maurice Bernardin, Edouard Morren, Duke of Wellington, Madame Willermoz, Dr. Andry, Mdle. Marie Cointet, A. K. Williams, La Boule d'Or, Edouard Hervé, Madame Hippolyte Jamain, Duke of Edinburgh, Innocente Pirola, Hippolyte Jamain, and Marie Finger. This was a surprisingly good collection. The second prize went to Messrs. Paul & Son, Cheshunt, who showed exceedingly well, and the third to Mr. Charles Turner, Royal Nurseries, Slough, in whose boxes Madame Gabriel Luizet was conspicuously good.

Class 3, forty-eight varieties. Messrs. J. Brunell & Co., How House Nurseries, Cambridge, here secured the first prize, staging the following varieties:—Ulrich Brunner, M. Noman, Beauty of Waltham, Maréchal Niel, Madame Prosper Laugier, Baronne de Rothschild, Etoile de Lyon, Madame Gabriel Luizet, François Michelin, La Boule d'Or, Duke of Teck, Marie Rady, Innocente Pirola, Duke of Edinburgh, Madame Eugene Verdier, Princess of Wales, Merveille de Lyon (excellent bloom), Hippolyte Jamain, Madame de Watteville, Marie Baumann, Marie Verdier, Jean Ducher, Duchesse de Vallombrosa, Fisher Holmes, La France, Etienne Levet, Horace Vernet, Madame Montet, M. Boncenne, Souvenir de Gabriel Drevet, Xavier Olibo, Constantin Fretiakoff, S. Reynolds Hole, Catherine Mermet, Abel Carrière, Pride of Waltham, Violette Bouyer, Dupuy Jamain, Maurice Bernardin (excellent), Madame Hippolyte Jamain, Prince Arthur, Madame A. Jacquier, Her Majesty, Louis Van Houtte, Comtesse de Nadaillac (very fine), Madame Cusin, Lady Mary Fitzwilliam, and Le Havre. This was a very even and fresh collection. The second prize went to Messrs. Curtis, Sanford, and Co., Torquay, their stand including noteworthy blooms of Madame Gabriel Luizet, Baronne de Rothschild, and Marguerite de St. Amand. The third prize fell to Messrs. John Cranston & Co., King's Acre, Hereford, for a little inferior collection, Her Majesty, Marie Rady, and M. Alfred Dumesnil being good. Fourth prize was awarded to Messrs. Jefferies & Son, Cirencester. Seven collections were staged in all.

Class 4, twenty-four distinct varieties. Mr. H. Merryweather, Southwell, was the most successful exhibitor in this class, his first prize stand being moderately good, but somewhat marred by a lack of freshness in some varieties. The following composed his stand:—Ulrich Brunner, Madame Lacharme, Etienne Levet, Lady Mary Fitzwilliam, Marie Rady, La France, Pride of Reigate, Madame Gabriel Luizet, Mdle. Marie Cointet, Madame Prosper Laugier, Madame de Watteville, Prince Arthur, Catherine Mermet, Charles Lefebvre, Marguerite de St. Amand, Comte de Raimbaud, Countess of Rosebery, Niphotos, François Levet, Madame Catherine Sompert, A. K. Williams, M. Noman, Madame Cusin, and Duchesse de Vallombrosa. The first-named bloom, it may be noted, received the silver medal as being considered the best Hybrid Perpetual in the show. It was a fine substantial bloom. Mr. J. Mattock, New Headington Nursery, Oxford, received the second prize, his flowers being fresh, and the third and fourth prizes went to Messrs. G. Mount, Rose Nurseries, Cantbury, and Messrs. G. Cooling and Son, Bath, respectively. Six stands were shown in all.

Class 5, twenty-four varieties, three trusses of each. Messrs. J. Jefferies and Co. secured a highly creditable victory in this class, their blooms being in excellent condition. The varieties were as follows:—Marquise de Castellane, Duchesse de Vallombrosa, Ulrich Brunner, Marie Cointet, Comtesse d'Oxford, Madame Gabriel Luizet, Madame Marie Verdier, Cannes La Coquette, Annie Laxton, Lady Mary Fitzwilliam, Rosieriste Jacob, Madame Montet, Maréchal Niel, Marchioness of Exeter, Merveille de Lyon, Marie Rady, Comtesse de Serenye, Etienne Levet, Niphotos, Louis Van Houtte, Marie Finger, Mrs. Charles Wood, Marguerite de St. Amand, and American Beauty. Messrs. John Cranston followed, their stand including several good blooms; and the third and fourth prizes went to Messrs. Cooling & Son and G. Mount, in the order named. Eight collections were in competition.

#### AMATEURS' CLASSES.

The competition was keen in the chief amateurs' class, and nine collections of forty-eight distinct single trusses were staged. The challenge trophy was won by W. J. Grant, Esq., Hope End Farm, Ledbury, Hereford, with an admirable stand of blooms, comprising some capital specimens for the season. The varieties were Sir Garnet Wolsley, Mems. Noman, Alfred Colomb, Merveille de Lyon, Annie Wood, Madame Welch, Duchess of Bedford, Souvenir d'Elise Vardon, Madame Crapelet, Her Majesty, Marie Rady, Marie Van Houtte, Le Havre, Catherine Mermet, Star of Waltham, Maréchal Niel, Général Jacqueminot, Anna Olivier, Ulrich Brunner, Belle Lyonnaise, Constantin Fretiakoff, Madame Gabriel Luizet, A. K. Williams, Louis Van Houtte, Marie Baumann, Duchesse de Vallombrosa, Camille Bernardin, Lady Mary Fitzwilliam, Charles Lefebvre, Comtesse de Nadaillac, Thomas Mills, Marquise de Castellane, Abel Carrière, Mdle. Eugénie Verdier, Lord Macanlay, Caroline Kuster, Xavier Olibo, Niphotos, Etienne Levet, La France, Duke of Wellington, Souvenir d'un Ami, Duke of Edinburgh, François Michelin, Charles Darwin, Heinrich Schultheis, La Rosière, and Countess of Oxford; the Rev. J. H. Pemberton, Havering, Romford, was a very good second with handsome blooms, amongst which was the premier Hybrid Perpetual in the amateurs' classes, Ulrich Brunner, very large, and handsome in colour, a magnificent bloom. Fine examples of Charles Lefebvre, Catherine Mermet, Souvenir d'Elise Vardon, and Horace Vernet were also shown. T. B. Hall, Esq., Rockfeiry, was third, and H. Slaughter, Esq., Juvis Villa, Steyning, fourth, both having creditable collections.

Class 7, twenty-four varieties, three trusses each. W. J. Grant, Esq., Ledbury, Hereford, secured the honours in this class with a creditable collection, the blooms mostly of moderate size but including a good proportion of well-formed samples, very clean and fresh in colour. The varieties represented were—Marie Rady, Duchesse de Vallombrosa, Charles Lefebvre, Madame Gabriel Luizet, Abel Carrière, Lady Mary Fitzwilliam, Caroline Kuster, Xavier Olibo, Niphotos, Le Havre, Catherine Mermet, Charles Darwin, Ulrich Brunner, Merveille de Lyon, Sir Garnet Wolsley, La France, François Michelin, Camille de Rohan, Alba Rosea, A. K. Williams, Marie Cointet, Louis Van Houtte, Souvenir d'un Ami, and Marquise de Castellane. The second place was adjudged to T. W. Girdlestone, Esq., Sunningdale,

Berks, some of his best blooms being Madame Bravy, François Michelin, and A. K. Williams. Mr. S. P. Budd, 8, Gay Street, Bath, was third with bright blooms, but several rather weak. There were three entries.

For the best thirty-six single trusses, E. B. Lindsell, Esq., Bearton, Hitchin, was accorded premier honours for an excellent collection of good blooms, comprising the premier Tea in the amateurs' classes, Comtesse de Nadaillac, of good size, grand form, and altogether a grand bloom. The others were—Lady Mary Fitzwilliam, Alphonse Souper, Souvenir d'Elise Vardon, Louis Van Houtte, La France, Marie Cointet, Alfred Colomb, Xavier Olibo, Charles Lefebvre, Madame Lacharme, A. K. Williams, Catherine Mermet, Her Majesty, Dr. Sewell, Violette Bouyer, Beauty of Waltham; Innocente Pirola; Abel Carrière, Madame G. Luizet, Horace Vernet, Madame Cusin, Le Havre, Mons. Noman, La Rosière, Maréchal Niel, Marie Baumann, Madame de Watteville, Duchesse de Morry, Niphotos, Marie Rady, Comte Raimbaud, Merveillé de Lyon, Ulrich Brunner, Captain Christy, and Marquise de Castellane. Mrs. Waterlow, Great Doods, Reigate (gardener, Mr. J. Brown) was second, noteworthy blooms in the stand being Eugène Furst, Pierre Notting, Marie Rady, Abel Carrière, Reynolds Hole, and Etienne Levet. W. H. Wakeley, Esq., Macklands, Rainham, was placed third, bright examples of A. K. Williams, Thomas Mills, Marie Rady, and Prince Arthur being observable. The Rev. A. Foster Melliar, Ipswich, was fourth, Alfred Colomb, Souvenir d'Elise Vardon, and Dupuy Jamain being his best blooms. There were seven exhibitors.

In Class 9 Mr. C. J. Day, Rowton, Chester, took the lead with twenty-four single trusses, showing bright fresh blooms of La France, A. K. Williams, Lady Mary Fitzwilliam, Dr. Sewell, Princess Mary of Cambridge, Prince Arthur, Madame Gabriel Luizet, Marie Rady, Cannes La Coquette, Lou's Van Houtte, Merveillé de Lyon, Barthelemy Joubert, Duchesse de Vallombrosa, Rosieriste Jacobs, Niphotos, Marquise de Castellane, Marie Cointet, Marie Baumann, Abel Carrière, Sénateur Vaisse, Catherine Mermet, François Michelin, Le Havre, and Camille Bernardin. G. Christy, Esq., Buckhurst Lodge, Westerham, was second. Earl Stanhope, Chivening, Sevenoaks (gardener, Mr. Gray), was third, and Rev. W. H. Jackson, Bedford, fourth. Six competitors entered.

With twelve tripets W. H. Wakeley, Esq., took the lead with Marie Rady, Marquise de Castellane, Madame Gabriel Luizet, Henri Lecéchaux, Violette Bouyer, Abel Carrière, Louis Van Houtte, Maréchal Niel, Baroness Rothschild, Camille Bernardin, François Michelin, and Mons. Noman. E. B. Lindsell, Esq., was a good second, Mrs. Waterlow third, and the Rev. W. H. Jackson fourth, with two other exhibitors.

Class 11, eighteen single trusses. The Rev. L. Garnett, Christleton, Chester, won the first prize with fresh, bright, and moderate-sized blooms of Madame Gabriel Luizet, Louis Van Houtte, Marquise de Castellane, Marie Cointet, Abel Carrière, Beauty of Waltham, Duchess of Bedford, La France, Emily Fortaise, Innocente Pirola, A. K. Williams, Madame Cusin, Horace Vernet, Catherine Mermet, Duke of Wellington, Ulrich Brunner, and Caroline Kuster. The second place was gained by Edward Mawley, Esq., Rosebank, Berkhamstead, with a good stand, of which the following were noteworthy:—Dupuy Jamain, Comtesse de Nadaillac, Marie Finger, Merveillé de Lyon, Lady Mary Fitzwilliam, and Marie Cointet. Miss Baker, Holmfels, Reigate (gardener, Mr. J. Budgen), was third, and Mr. W. Narrows, Headington Quarry, Oxford, fourth. There were eight exhibitors.

Class 12, twelve single trusses. Amongst the nine exhibitors the Rev. Alan Cheales, Brockham Vicarage, Surrey, won first honours with clean blooms of Captain Christy, Maréchal Niel, Marie Baumann, Madame Gabriel Luizet, Charles Lefebvre, François Michelin, Lady Mary Fitzwilliam, Countess of Rosebery, Star of Waltham, Mons. Noman, Etienne Levet, and Madame Lambard. Mr. H. Wallace, Breutwood, followed, his examples of Madame Gabriel Luizet, Catherine Mermet, and Souvenir d'Elise Vardon being very notable. Mr. H. Shoesmith, gardener, Saltwood Rectory, Hythe, was third, and Mr. H. H. Hayward, Ealing, fourth.

Class 13, nine single trusses. J. Bateman, Esq., 72, Twisden Road, Highgate Road, took the lead in a class of nine competitors with Ulrich Brunner, Madame Gabriel Luizet, Le Havre, Lady Mary Fitzwilliam, François Michelin, Marquis de Castellane, Camille Bernardin, Baroness Rothschild, and Marie Rady. Mr. E. Wilkins, Lyndhurst, Sutton, Surrey, was second with several good blooms in an even stand. Julius Sladden, Esq., Badsey, Evesham, was third, and Mr. C. E. Cuthell, Chapel Croft, Dorking, fourth.

Class 14, six distinct single trusses. Seven exhibitors entered in this class. T. T. Burnaby Atkins, Esq., Halstead Place, Sevenoaks (gardener, Mr. A. Gibson), was adjudged first honours for Ulrich Brunner, Baroness Rothschild, Comtesse de Nadaillac, Marie Baumann, Madame Gabriel Luizet, and Madame Bravy. O. G. Orpen, Esq., Hillside, Colchester, was second, showing a fine bloom of Avocat Dubivier. Mr. H. Foster, High Street, Ashford, Kent, third, having Xavier Olibo very neat and rich, and Rev. F. S. Taylor, Littleton Vicarage, Evesham, fourth.

#### EXTRA CLASSES.

Class 15, six single trusses, open only to amateurs who have never won a prize at an exhibition of the National Rose Society. Only four stands were shown in this class. O. G. Orpen, Esq., leading with Innocente Pirola, Princess of Wales, Caroline Kuster, Madame Cusin, Maréchal Niel, and Souvenir d'un Ami; W. D. Freshfield, Esq., Parkside, Reigate, second; Mr. W. W. Northover, Haslemere, Wimbledon, third, and O. T. Hodges, Esq., Lachine, Chislehurst, fourth, with small blooms.

Class 16, six single trusses of Roses grown within eight miles of Charing Cross. J. Bateman, Esq., was first for Ulrich Brunner, Madame Gabriel Luizet, Duchesse de Vallombrosa, Countess of Rosebery, Etienne Levet, and Le Havre. Mr. W. Northover was awarded the second prize.

Class 17, six new Roses offered for the first time in English nurserymen's lists in 1884. Mr. H. Shoesmith, was first with Benoit Comte, Her Majesty, Clara Cochét, Dr. Dor, Madame de Watteville, and Souvenir de Gabrielle Drevet.

Class 18, six single trusses of any Hybrid Perpetual Rose. There was a keen competition in this class, twenty exhibitors staging blooms, and the majority were good. J. Gurney Fowler, Esq., Glebelands, Woodford, Essex, secured leading honours with magnificent blooms of Ulrich Brunner, large, bright, fresh, and of good substance; W. J. Graut, Esq., Hope End Farm, Ledbury, Hereford, was second with the same variety but smaller blooms;

T. B. Hall, Esq., was third with La France; Rev. J. H. Pemberton, Havering, Romford, was fourth with A. K. Williams of medium size, fairly good shape and colour.

Twelve stands of six Teas or Noisettes were staged, the Rev. Alan Cheales gaining the first place with Maréchal Niel, very handsome, large, substantial richly coloured blooms. The Rev. H. A. Berners followed closely with Comtesse de Nadaillac, charming blooms of excellent form. W. J. Grant, Esq., was third for the same variety, and E. Mitchell, Esq., Romford, fourth for Madame Margottin.

#### TEA AND NOISETTE CLASSES.

NURSERYMEN'S CLASSES.—The Tea and Noisette Roses were grandly shown in all the classes devoted to them, and they constituted the leading feature of the exhibition. Five handsome collections of twenty-four Tea and Noisette Roses were shown in class 20, equal first prizes being awarded to Mr. B. R. Cant, Colchester, and Mr. G. Prince, Oxford. Mr. Cant's varieties were Madame Hippolyte Jamain, Souvenir d'un Ami, Madame Angèle Jacquier, Etoile de Lyon, Catherine Mermet, Maréchal Niel, Innocente Pirola, Souvenir d'Elise Vardon, Marie Van Houtte, Madame Welch, La Boule d'Or, Comtesse de Nadaillac, Jules Finger, Moiré, Niphotos, Madame Margottin, Princess of Wales, Hon. Edith Giffard, Madame Caroline Kuster, Madame de Watteville, Devoniensis, Claudius Levet, Anna Ollivier, and Madame Willermoz. Mr. Prince's blooms comprised the following:—Maréchal Niel, Catherine Mermet, Anna Ollivier, Souvenir d'un Ami, Souvenir de Paul Neyron, Princess of Wales, Innocente Pirola, Comtesse de Nadaillac, Homère, Hon. Edith Giffard, Madame Hippolyte Jamain, Niphotos, Souvenir d'Elise Vardon, Perle des Jardins, Marcelin Rhoda, Marquis de Sannina, Marie Van Houtte, Mlle. M. Arnaud, La Princess Vera, Jean Ducher, Etoile de Lyon, Madame A. Jacquier, La Boule d'Or, and Madame Willermoz. Mr. F. Cant was third, and Mr. G. W. Piper, Uckfield, fourth, with good stands.

In class 21, for eighteen Teas or Noisettes, there were eight strong exhibitors, all the blooms being remarkably clean and bright. Premier honours were accorded to Messrs. J. Burrell & Co., Cambridge, for very handsome blooms of La Boule d'Or, Madame Margottin, Jean Ducher, Catherine Mermet, Marie Gnillet, Souvenir de Madame Pernet, Etoile de Lyon, Innocente Pirola, Madame Bravy, Madame Cusin, Madame Angèle Jacquier, Niphotos, Madame de Watteville, Rubens, Francis Kruger, Devoniensis, Comtesse de Nadaillac, and Maréchal Niel. Messrs. Harness and Sons were second with small, neat blooms; Mr. G. Mount, Canterbury, third, and Mr. J. Mattock, Oxford, fourth.

For twelve trusses of any Tea or Noisette Rose, Maréchal Niel excepted, Mr. Frank Cant, Colchester, was first with remarkably beautiful even blooms of Souvenir d'Elise; Mr. G. Prince followed with Comtesse de Nadaillac; Messrs. Paul & Son, Cheshnut, third with Niphotos; and Mr. B. R. Cant fourth for Catherine Mermet, neat, clean blooms. There were five competitors.

Mr. B. R. Cant was awarded the first prize for eighteen Teas or Noisettes, three blooms of each, and exhibited the following varieties:—Niphotos, Madame Caroline Kuster, Souvenir d'un Ami, Marie Van Houtte, Innocente Pirola, Comtesse de Nadaillac, Catherine Mermet, Madame Margottin, Rubens, Hon. Edith Giffard, Maréchal Niel, Madame de Watteville, Souvenir d'Elise, La Boule d'Or, Etoile de Lyon, Madame Cusin, Madame Welch, and Devoniensis; Mr. F. Cant took the second place, Mr. G. Prince the third, showing the premier Tea Rose in the nurserymen's class, Comtesse de Nadaillac, very handsome, substantial bloom; Messrs. Paul & Son were fourth.

AMATEURS' CLASSES.—In these competition was brisk, and some of the most noteworthy flowers in the Show were included in the amateurs' stands. The Rev. J. Page Roberts, The Rectory, Scole, Norfolk, secured the premier award for eighteen Tea or Noisette varieties, his charming stand comprising beautiful blooms of Maréchal Niel, Comtesse de Nadaillac, Alba Rosea, and Madame Hippolyte Jamain, amongst others. Mr. Harris, gardener to E. M. Bethune, Esq., Deane Park, Hortham, was a creditable second. W. J. Grant, Esq., Hope End Farm, Ledbury, Hereford, third; and the Rev. E. G. King, Madingley Vicarage, Cambridge, fourth; an extra prize being awarded to the Rev. J. R. Burnside, Chipping Campden. There were eight collections in all, and they formed a very attractive class. A similar remark applies to the succeeding class—that for twelve Teas or Noisettes, ten stands being in competition. Mr. Brown, gardener to Mrs. Waterlow, Great Doods, Reigate, secured a well-deserved victory, a beautiful bloom of Souvenir d'Elise, an equally meritorious one of Princess of Wales, with charming examples of Comtesse de Nadaillac and Catherine Mermet, forming features of a fine stand. G. Christy, Esq., Buckhurst Lodge, Westerham, was a fair second, showing Niphotos and Alba Rosea well. The Rev. A. Foster Melliar, Ipswich, was third, and W. H. Wakeley, Esq., Macklands, Rainham, fourth.

There were six contestants in the class for nine Tea or Noisette varieties, victory resting with the Rev. L. Garnett, Christleton, Chester. Madame Cusin, Comtesse de Nadaillac, and Souvenir d'un Ami were best shown, but all were bright and fresh. The second prize flowers of Alfred Slaughter, Esq., Steyning, were fresh and clear, but small, and very little in advance of the third prize stand, sent by Mr. Budgen, gardener to Miss Barker, Holmfels, Reigate. The fourth prize went to Mr. H. Shoesmith, Saltwood Rectory, Hythe. Lieut.-Colonel Standish-Hore, Roschill, St. Asaph, was first amongst eleven competitors in the class for six Teas or Noisettes. A grand bloom of Souvenir d'Elise Vardon was the most conspicuous flower in this stand. E. Horne, Esq., Park House, Reigate, was a close second; the Rev. Alan Cheales, Brockham Vicarage, Surrey, a good third; and the Rev. F. S. Taylor, Littleton Vicarage, Evesham, fourth.

For twelve Teas or Noisettes, three trusses of each, Mr. Eldout, gardener to T. B. Hayward, Esq., Woodhatch Lodge, Reigate, was first with a fine stand, Catherine Mermet being particularly good, and Innocente Pirola noteworthy. The Rev. F. Burnside was second, his flowers being somewhat small, but in capital condition. The Rev. W. H. Jackson, Bedford, was third, and the Rev. F. Page Roberts, fourth. Six collections were staged.

#### OPEN CLASSES.

A very interesting class was that for garden Roses, in which there was an unusual number of entries, seven exhibitors contributing good stands.



Julius Sladden, Esq., Badsey, Evesham, Worcester, secured first honours for a collection that attracted much attention, and which comprised the following—La Ville de Bruxelles (Damask), the real York and Lancaster (Damask), Reine Marie Henriette (Hybrid China), Belle Maconnaise (Tea), Rosa Mundi (French), The Garland (Hybrid Climbing), Aimée Vibert (Noisette), Austrian Briar, Alba Felicité, Crimson China, Hybrid Provence, Hypatia, Triomphe de Bayeux, Polyantha, Fabvier (China), Moss Princess Royal, Old Blush (China), Narcisse (Noisette), Fellenberg (Noisette), Double Margined Hip (Hybrid China), Queen (Bourbon), Homer (Tea), rugosa rubra, Bongère (Tea), and Alba La Séduisante. Messrs. John Cranston and Co., King's Acre, Hereford, were awarded the second prize, also for an interesting collection of old Roses; the Rev. J. H. Pemberton being third, and Mr. John Walker, Thame, fourth.

With twelve bunches of Moss and Provence Roses, Messrs. Paul & Son were first, their best varieties being Lanei, White Bath, Blanche Moreau, Cristata and Perpetual White Moss, all being pretty. Messrs. G. Bunyard and Co., Maidstone, were second, Little Gem, Reine Blanche, and Blanche Moreau being very notable amongst the Moss Roses. Mr. J. House, Peterborough, was third.

Eight beautiful stands of buttonhole Roses were exhibited, Mr. J. Mattock, Oxford, securing first honours with a charming collection, comprising the following—W. F. Bennett, Rubens, Comtesse de Nadaillac, Jean Pernet, Madame Falcot, W. A. Richardson, Marie Van Houtte, W. F. Bennett, Souvenir de Paul Neyron, Homère, Niphotos, and Devoniensis.

Messrs. Harkness & Sons, Bedale, were second, their best varieties being La Rosière, Madame Lambert, Madame Willermoz, Marie Van Houtte, Souvenir d'un Ami, Aloa Rosea, and Catherine Mermet. Messrs. G. Bunyard and Co. were third with a good collection, comprising most of the preceding varieties, with some others, David Pradel of the Madame Cusin type being notable.

For twelve new Roses first offered in English lists in 1884, Messrs. Curtis, Sanford & Co., Torquay, were first with Her Majesty, Madame Banlot, Comtesse de Frignense, General Appert, Madame Norman Neruda, Souvenir de Victor Hugo, Baroness Nathaniel de Rothschild, Victor Hugo, The Bride, Laurent de Rille, Princess Amelia d'Orleans, and Roul Guillard. Messrs. Paul & Son were second with several of the preceding, together with Pride of Reigate, Clara Cochet, Mary Bennett, Marshal P. Wilder, and Ella Gordon. Mr. B. R. Cant was third.

In class 33, for twelve single trusses of any new Rose first offered in English lists in 1884, there was a good display. Mr. B. R. Cant took the lead with grand blooms of the Tea Madame de Watteville, white tinged rose, charming. Messrs. G. Cooling & Son, Bath, were second with good blooms of Her Majesty. Mr. H. Bennett, Shepperton, was third with Princess Beatrice, the pedigree seedling Tea, which has already been certificated several times, and Messrs. Curtis, Sanford & Co. fourth with Her Majesty, this variety also being shown by another exhibitor. J. Bateman, Esq., was second, showing Madame de Wellenstein, Grace Darling, Gloire Lyonnaise, Mr. G. Dickson, Madame de Watteville, and Her Majesty. T. W. Girdlestone, Esq., was third.

Maréchal Niel was strongly in evidence in the class for twelve trusses of any yellow Rose. Seven stands were in competition, Mr. B. R. Cant taking first place with the variety named in fair condition, Mr. G. W. Piper, Uckfield, the second, and Mr. Frank Cant the third, both with the Maréchal. Mr. W. J. Grant was fourth with Madame Caroline Kuster. Eleven growers were represented in the succeeding class—that for a similar number of white Roses, Merveille de Lyon being the variety selected in seven cases. A magnificent stand of this variety from Mr. B. R. Cant easily took the first prize, Mr. Piper secured the second with a charming lot of Niphotos: T. W. Girdlestone, Esq., Sunningdale, Berks, the third with Duchesse de Vallombrosa; and Mr. S. P. Budd the fourth with Merveille de Lyon.

There were four stands to divide the four prizes for twelve crimson flowers. Messrs. Curtis, Sanford & Co., Torquay, were first with neat blooms of Marie Rady; Mr. R. E. West, Firth Dene, Reigate, second, with Ulrich Brunner in excellent condition; Messrs. G. Bunyard & Co., Old Nurseries, Maidstone, third with the same variety, and Messrs. G. Cooling and Sons, fourth with A. K. Williams. Messrs. J. Cranston & Co., Curtis and Sanford, and B. R. Cant were the only competitors with twelve blooms of a dark velvety crimson variety, and the first, second, and third prizes went to them in the order their names are placed, the first and second prize lots being composed of Abel Carrière, and the third of Reynolds Hole.

For twelve single trusses of any Rose there were twelve competitors, the first prize going to Mr. H. Bennett, Shepperton, Middlesex, for neat blooms of Lady Mary Fitzwilliam, the second to Mr. Grant for fine blooms of Ulrich Brunner, the third to Mr. Frank Cant for Madame G. Luizet, and the fourth to Messrs. Curtis, Sanford & Co. for Ulrich Brunner.

#### CANTERBURY AND EAST KENT.

ALTHOUGH there are other Societies who are earlier in the field—Torquay, Ryde, Croydon, and Bagshot—yet Canterbury is generally the one, if not always so, at which I commence my annual circuit. I looked forward to it with no small degree of interest, not only because the old city is very dear to me and I have many good friends there, but especially was I anxious this year, as I wanted to find out how far my anticipations had been realised with regard to the season. To an exhibitor I look upon this as a perfect season, provided he has a good supply of water. It is anything but a perfect season to my good friend Mr. Biron on the top of Lympne Cliff, where, as he once said, he might as well attempt to give them real champagne as to supply them with water, and where, moreover, his Roses attract so much attention and excite the interest of his neighbours so much, that they occasionally send half a score of sheep and lambs to inspect them; but to the exhibitor who has plenty of water the weather is superb. The temperature is modified by the north-east wind, and so the high-coloured Roses do not get scorched, while the light Roses which so rejoice in rainless skies are not splashed or dirtied by bad weather. There is at present no high wind, and as far as my poor judgment goes amateurs are having a good time of it. Nurserymen are not able to give perhaps so much attention to watering, owing to their large stock, but even for them the time is a good one. These notions which I have entertained about the season are fully borne out by the Roses which were exhibited at

Canterbury. They were good in colour, true to character, and very clear; and that this was not confined to one or two persons may be seen from the fact that in nearly all the classes the stands ran so closely that it became necessary to go through the blooms by points, and in most instances the contest was very close.

The stand of eighteen varieties with which Mr. W. H. Wakley of Rainham won the prize and also the National Rose Society's silver medal for the best box in the show contained some very perfect Roses, and indeed the whole stand was one of rare excellence. The sorts were Dr. Sewell, a grand bloom; Ferdinand de Lesseps, Comtesse de Nadaillac, very fine; Alphons Souper, A. K. Williams, Innocente Pirola, Jules Finger Rosieriste Jacobs, Maréchal Niel, Beauty of Waltham, Dr. André, Gloire de Bourg la Reine, without doubt the finest bloom I have seen of this very high coloured flower; Eugène Fürst, Mons. Noman, Prince Arthur, very fine; Duke of Edinburgh. The second prize was gained by Mr. F. Warde of East Farleigh with a stand containing fine blooms of Royal Standard, Louis Van Houtte, Maréchal Niel, Duke of Edinburgh, Catherine Souper, Charles Lefebvre, a grand bloom, to which fell the prize for the best Rose in the show; Sénateur Vaisse, Belle Lyonnaise, Marie Rady, Annie Laxton, Reynolds Hole, La France, Duke of Teck, Constantine Fretiakoff, A. K. Williams, Marguerite de St. Amand, Beauty of Waltham, and Jules Finger. In another class Mr. Warde secured the first place with Dupuy Jamain, Xavier Olibo, Prince Arthur, Belle Lyonnaise, Charles Lefebvre, La France, Maréchal Niel, Gabriel Luizet, Duke of Edinburgh, Comtesse de Nadaillac. The second was taken by a veteran grower, Mr. J. Hollingworth of Maidstone, his box containing Ernest Boncenne, Madame Hippolyte Jamain, La France, Marie Baumann, Moss. Boncenne, Maréchal Niel, Alfred Colomb, Eugène Verdier, Dr. André, Comtesse Pamise, and Madame Gabriel Luizet.

In class 3, for twelve Teas or Noisettes, Mr. Wakley was first with a fine box of Caroline Kuster, Innocente Pirola, Jean Ducher, Souvenir d'un Ami, Maréchal Niel, Princess of Wales, Perle des Jardins, Marie Van Houtte, Souvenir de Thérèse Levet, Madame Bravy, Niphotos, and Catherine Mermet. The second was taken by Mr. F. Warde with Etoile de Lyon, Comtesse de Nadaillac, Bongère, Madame Hippolyte Jamain, Innocente Pirola, Catherine Mermet, Maréchal Niel, Madame Lambert, and Souvenir d'un Ami. In class 4, for six varieties, three trusses of each, Mr. Wakley was again first with Maréchal Niel, Henri Lédéchaux, Mad. G. Luizet, A. K. Williams, Edith Giffard, and Duke of Wellington. Mr. E. K. West of Reigate was second with La France, Marie Baumann, Captain Christy, Madame Gabriel Luizet, and Xavier Olibo. In class 5, nine varieties, Mr. G. Packham was first with Maréchal Niel, La France, Louis Van Houtte, Etienne Levet, A. K. Williams, Marquise de Castellane, Charles Lefebvre, and Captain Christy. Mrs. Wachter was second. In class 6, for six Teas or Noisettes, Miss Hawksworth was first with fine blooms of Anna Ollivier, Souvenir de Thérèse Levet, Rubens, Souvenir d'un Ami, Catherine Mermet, and Etoile de Lyon. In class 7, for three varieties, three trusses of each, the first prize was taken by Mr. Dean with A. K. Williams, Maréchal Niel, and La France. In class 8, for six varieties, Mr. S. Hill Deau, the Treasurer of the Society, took first with Souvenir d'un Ami, Duchess of Bedford, Louis Van Houtte (a very fine bloom), Jules Finger, Prince Arthur, Madame Cusin. In class 9, three varieties, Mr. Dean was also first with Prince Arthur, Anna Ollivier, and Niphotos. Mr. B. Tassell was second. In class 10, three Teas or Noisettes, Mr. Dean was again first with Souvenir de Paul Neyron, Madame Berard, and Niphotos. In class 11, for those who have never taken a first prize at this Society's shows, Mr. H. Foster of Ashford had first with Mrs. Baker, Marie Van Houtte, Jean Luzin, Ferdinand de Lesseps, Marquise de Castellane; and in class 12, six trusses of any Rose, Mr. F. Warde was first with Maréchal Niel, and Mr. E. G. Pentham second with A. K. Williams.

There were two classes open to all England, and in one of these both nurserymen and amateurs can compete. There was a very spirited contest indeed, the first place being eventually secured by Mr. Wakley. The class is for twelve Teas and Noisettes. The winning stand had fine examples of Madame Welch, Souvenir de Thérèse Levet, Niphotos, Marie Van Houtte, Souvenir de Madame Pernet, Madame Bravy, Maréchal Niel, Innocente Pirola, Laurette, a very pretty Homère-like flower; Hon. Edith Giffard, Madame Margottin, and Caroline Kuster. Messrs. Paul & Son, Mr. Geo. Paul, and Mr. Geo. Mount ran so closely that they were awarded equal seconds. Messrs. Paul & Son's flowers were Souvenir d'un Ami, Niphotos, Francisca Kruger, Gloire de Dijon, Maréchal Niel, Duchess of Edinburgh (the best bloom of this Rose I ever saw), Devoniensis, President, Madame de Watteville, Comtesse de Nadaillac, and Jean Ducher. Mr. George Mount's were Madame de Watteville, Innocente Pirola, Marie Van Houtte, Anna Ollivier, Maréchal Niel, Souvenir d'Elise Vardon, Adam, Souvenir d'un Ami, Souvenir de Paul Neyron, Madame Cusin, and Catherine Mermet.

In the class for thirty-six varieties Messrs. Paul & Son were first with Comte Raimbaud, Madame Hippolyte Jamain, Alfred Dumesnil, Baroness de Rothschild, Abel Carrière, Alphonse Souper, Prince Arthur, Abel Grand, Sultan of Zanzibar, Lady Mary Fitzwilliam, Ulrich Brunner, Souvenir d'un Ami, Centifolia Rosea, Duke of Edinburgh, Niphotos, Beauty of Waltham, Etienne Levet, Marie Baumann, Madame Eugénie Verdier, Maurice Bernardin, Comtesse de Morny, Lady Alice (new, a sport from Lady Mary Fitzwilliam), A. K. Williams, Dr. André, Madame Gabriel Luizet, Marshal P. Wilder (a promising American Rose), Duchesse de Vallombrosa, Prince Camille de Rohan, Annie Laxton, Marie Rady, Madame de Watteville, Victor Hugo, Marie Cointet, Camille Bernardin, and M. Isaac Pereire. Mr. Geo. Mount's were Captain Christy, John Hopper, Annie Laxton, Madame Eugénie Verdier, Ulrich Brunner, Abel Carrière, Her Majesty, Général Jacqueminot, Anna Ollivier, Marie Baumann, Madame Gabriel Luizet, Horace Vernet, Prince Arthur, Henrich Schultheis, Catherine Mermet, Madame Nachury, E. Y. Teas, La France, Duke of Wellington, Dupuy Jamain, Jules Finger, Lady Mary Fitzwilliam, Hippolyte Jamain, Sénateur Vaisse, Innocente Pirola, Louis Van Houtte, Baroness Rothschild, La Rosière, Marie Van Houtte, Violette Bouyer, Eugène Fürst, Maréchal Niel, Duke of Teck, Etienne Levet, and Madame Willermoz.

The excellence of the blooms staged to-day augurs well for the success of the Rose season, and I should imagine that the display at the National



on Tuesday will be one of the best the Society has ever brought together.—*D., Deal.*

#### EAST GLOUCESTERSHIRE (MORETON-IN-MARSH).—JUNE 30TH.

THE annual Exhibition of this Society was held in the large cricket field adjacent to the railway station. Two large marquees had been erected, and more than ample space was available for all the growers who competed, some of whom came from distances as far as Bath, Colchester, Canterbury, Cirencester, Oxford, and Ledbury. The President's special prize of £10, supplemented by the Society with three others for twenty-four varieties, open to all, excited keen competition, and what was especially notable was the increased proportion of the Teas in the two first divisions, and the uniformly high quality of the blooms staged of them throughout.

In the first division for nurserymen, class 1, for thirty-six varieties, the premier position was taken by Mr. B. R. Cant, Colchester, who staged remarkably fine blooms, amongst them being Mons. A. Dumesnil, Fisher Holmes, Marie Baumann, Duke of Edinburgh, Sultan of Zanzibar, very vivid; Reynolds Hole, Alfred Colomb, Dr. Sewell, A. K. Williams, Ulrich Brunner, Mons. Noman, Baroness Rothschild, Magna Charta, Madame Clemence Joigneaux, Duchesse de Vallombrosa, Marguerite de St. Amand, Etienne Levet, Ville de Lyon, Merveille de Lyon, Lady Mary Fitzwilliam, superb; Madame de Watteville, Innocente Pirola, Souvenir d'Elise Vardon, very fine; Catherine Mermet, Madame Cusin, Maréchal Niel, Niphetos, and Souvenir d'un Ami. The second prize was likewise hailed from Colchester, and was staged by Mr. Frank Cant, notable flowers in this exhibit being Dupuy Jamain, Duke of Teck, Le Havre, Marie Baumann, Alfred Colomb, Countess of Rosebery, very bright; Her Majesty, Mdlle. Marie Cointet, Marie Finger, Catherine Mermet, fine; Jean Ducher, Madame Bravy, Maréchal Niel, Marie Van Houtte, Souvenir d'un Ami, Souvenir d'Elise Vardon, exquisite; and Souvenir de Paul Neyron. Messrs. Geo. Cooling & Sons, Bath, were third, a few of their most noteworthy flowers being Merveille de Lyon, Countess of Pembroke, Lady Mary Fitzwilliam, Princess of Wales, and Etoile de Lyon.

In class 2, for twelve Roses of one variety (dark), Mr. B. R. Cant was first with large highly coloured blooms of Duke of Edinburgh; Mr. Geo. Mount, Canterbury, taking the second prize with Fisher Holmes, and Messrs. Geo. Cooling & Son the third with A. K. Williams. In class 3, for twelve Roses of one variety (light), Mr. B. R. Cant was again first with a very fine stand of Lady Mary Fitzwilliam. Mr. George Prince, Oxford, was second with a charming stand of Souvenir d'Elise Vardon, and Messrs. Jefferies & Son, Cirencester, were third with Lady Mary Fitzwilliam. The competition in this class was keen, and the appearance of the exhibits occasioned general expressions of admiration. For the guidance of exhibitors in the two latter classes it was specified in the Society's schedule of prizes that in the former they should not be of a lighter colour than Général Jacqueminot, and in that of the other they should not be darker than Eugénie Verdier.

In the division for amateurs of all England, in class 4, for twenty-four varieties, Mr. W. J. Grant, Ledbury, succeeded in taking first honours, in his stand being very fine blooms of Marie Baumann, Horace Vernet, Ulrich Brunner, Auguste Rigotard, Duchesse de Vallombrosa, La Duchesse de Morny, La France, Louis Van Houtte, Souvenir d'Elise Vardon, Jean Ducher, and Comtesse de Nadaillac; the second prize was awarded to Mr. S. P. Budd, Bath, who staged fine examples of Alfred Colomb, Countess of Pembroke, Mons. Noman, Louis de Savoie, Ulrich Brunner, and Souvenir d'un Ami.

In class 5, for eighteen varieties, from which exhibitors in the last one were excluded, the premier position was taken by Miss Watson Taylor, Headington, Oxford, and it was from this stand that the Judges selected the best Tea or Noisette exhibited—namely, Maréchal Niel, for the distinction of being awarded the National Rose Society's silver medal. Of the other most noteworthy blooms in this exhibit may be mentioned those of Charles Lefebvre, Marie Baumann, St. George, A. K. Williams, Dupuy Jamain, Baron Adolph de Rothschild, Magna Charta, La France, Alba Rosea, Devoniansis, David Pradel, Catherine Mermet, Comtesse de Nadaillac, Jean Ducher, and La Boule d'Or. The second prize was taken by Mr. A. Evans, Marston, Oxford, in whose stand were very fine blooms of Belle Lyonnaise, Catherine Mermet, La France, Mons. Noman, Marie Baumann, and Harrison Weir. The third prize was awarded to Mr. Wm. Narroway, Headington Quarry, Oxford. So, as will be seen, the Oxford growers in this class swept the board.

In class 6, for twelve varieties, the first prize was secured by Mr. J. S'adden, Badsey, Evesham, who staged superb blooms of Belle Lyonnaise, Maréchal Niel, Souvenir d'Elise Vardon, and A. K. Williams. The second prize was won by the Rev. F. R. Burnside, Chipping Campden, whose most noteworthy blooms were those of Countess of Rosebery, Madame Angele Jacquier, and Jean Ducher.

In class 7, for six varieties, the first prize was awarded to the Rev. F. S. Taylor, Littleton Vicarage, Evesham, who staged very fine blooms of Belle Lyonnaise, Souvenir d'un Ami, Maréchal Niel, Marie Baumann, Thomas Mills, and Madame Gabriel Luizet. The second prize was taken by Mr. J. R. Neave, Chipping Campden, and the third by Mr. C. E. Morris of the same place. In class 8, for six Roses, one variety, Miss Watson Taylor was first with a fine stand of La France; the Rev. F. R. Burnside second with Maréchal Niel, and the Rev. F. S. Taylor third with the same variety. In class 9, for twelve varieties, three trusses of each, Mr. W. J. Grant exhibited an excellent stand and secured the first prize; Miss Watson Taylor being second, and Mr. S. P. Budd third. This class proved a very attractive one; the varieties of Teas already mentioned being exceedingly well shown.

The special prize of £10 presented by the President of the Society, A. B. Freeman-Mitford, Esq., C.B., Batsford Park, for the best twenty-four varieties in class 10, was awarded to Mr. W. J. Grant, who likewise won the National Rose Society's silver medal for the best H.P. Rose, his Xavier Olibo in this stand being selected for this honour. This stand of Roses was deservedly the admiration of all, and must be considered as a decidedly well-deserved amateur's triumph. The second prize was taken by Mr. B. R. Cant, the third by Mr. Frank Cant, and the fourth by Mr. George Prince, Oxford.

In class 11, the Tea and Noisette division for nurserymen, for twenty-four varieties Mr. B. R. Cant was first, Mr. George Prince second, and Mr. Frank

Cant third. In class 12, for eighteen varieties, Mr. B. R. Cant was first, Mr. George Prince second, and Messrs. Jefferies third. In class 13, for twelve varieties, Mr. B. R. Cant was again first, Mr. Frank Cant second, and Mr. George Prince third.

In class 14, Tea and Noisette division for amateurs, for eighteen varieties the Rev. F. R. Burnside was first, Mr. W. J. Grant second, and Miss Watson Taylor third. In class 15, for twelve varieties, Mr. S. P. Budd was first, Mr. J. Sladden second, and Mr. Wm. Narroway third. In class 16, for six varieties, the Rev. F. J. Taylor was first, and the Rev. J. A. Williams second. In class 17, a special prize given in kind by Mr. B. R. Cant, Miss Watson Taylor was first, the Rev. F. R. Burnside second, and Mr. W. J. Grant third.

In the class restricted to ladies, for hand bouquets, the Moreton ladies secured the prizes, the Misses Snowdon being placed first, Miss Ina Moore second, and Miss Allen third. For the prizes offered to cottagers for three varieties of Roses, three competitors only were represented, and the exhibits suggested that the growers of them might profit by a little instruction in the matter of staging.

Two more classes have to be noticed, and they are certainly not the least interesting—the one open to Moreton school children for a basket of wild flowers, given by A. B. Winterbottom, Esq., M.P., and that for a collection of Grasses and wild flowers. These two classes attracted no less than sixty-six competitors, and the exhibit that gained first honours in the former class was as well finished and elegant an arrangement of wild flowers as a child even of a larger growth could well conceive.

Extra productions were staged by Messrs. R. Smith & Co., Worcester, and Mr. George Prince, Oxford, the former sending boxes of flowers of herbaceous and bulbous plants, Clematis, &c., and the latter a beautiful stand of Tea Roses, Comtesse de Nadaillac.

#### ELTHAM.

I HAVE more than once alluded to the very delightful quaintness and Old-World air there is about this pretty village, only within eight miles of Charing Cross, and the very pleasing little Rose Show which is annually held here on the first Saturday in July. This year the Show, which was held in the pretty grounds of H. M. Gordon, Esq., was considerably improved by the fact that the Crystal Palace Show, which is generally held on the same day, had been postponed for a week; and thus Messrs. Paul and Son, Cant, West, Rumsey, Pemberton, and others were enabled to compete, and in the classes for twenty-fours and twelves ran a very close race. As usual, amongst the amateurs Mrs. Fuller was far ahead of her competitors; while the Jubilee class, one of those demoralising prizes which I think are not really conducive to the best interests of Rose-showing, brought a good competition. It was only for six Roses, confined to growers in the parish of Eltham. There was only one prize—a piece of plate valued £13—more than is usually given for seventy-two Roses! As showing how little one can speculate on weather, the observations I made on this subject about Canterbury are totally inapplicable now. The thermometer has gone into the 80's, and the season promises to be a very short one.

In the class for eighteen Roses Mrs. Fuller was easily first with a good stand of well-coloured flowers of the following varieties:—Dr. André, Captain Christy, Violette Bouyer, Dupuy Jamain, Louis Van Houtte, Abel Carrière, Comtesse d'Oxford, Alfred Colomb, Marquise de Castellane, Prince Arthur, Etienne Levet, Xavier Olibo, Ferdinand de Lesseps, and Marguerite de St. Amand. This box also obtained the National Rose Society's silver medal for the best box in the Show, and the bloom of Etienne Levet obtained the prize for the best Rose in the Show. Mrs. Fuller also obtained the prize for four trebles with La France, Camille Bernardin, Madame Gabriel Luizet, and Charles Lefebvre. In the class for six Teas Mr. Ongley was first with Jean Ducher, Caroline Kuster, Catherine Mermet, Souvenir de Paul Neyron, Comtesse de Nadaillac, and Madame Berard. In the Jubilee class the contest was very close with Mr. Ongley and Mr. R. Bloxam, and was ultimately awarded to the former, while a silver medal was recommended for the latter. Mr. Ongley's flowers were Souvenir d'Elise, Gabriel Luizet, Mons. Noman, A. K. Williams, Marquise de Castellane, and Caroline Kuster. Mr. Bloxam's flowers were Duke of Connaught, Belle Lyonnaise, Henri Ledechaux, Bouquet d'Or, Xavier Olibo, and Lady Mary Fitzwilliam.

In the open classes (open to nurserymen and amateurs alike) there was a strong competition in the class for twenty-fours, as will be seen when I mention that Messrs. Paul & Son, B. R. Cant, Rumsey, West, and the Rev. J. H. Pemberton entered into the contest. The first prize was awarded after a very close competition to Messrs. Paul & Son for the following:—Baronne de Rothschild, Magna Charta, Madame Gabriel Luizet, Duke of Edinburgh, Comtesse F. de Bollinger (new), Merveille de Lyon, Marie Baumann, François Michelon, Lady Mary Fitzwilliam, Camille Bernardin, Niphetos, Xavier Olibo, Her Majesty, Baron Donstettin, Etienne Levet, Charles Darwin, F. Levet, Dupuy Jamain, Lady Alice (a sport with a yellowish tinge from Lady Mary Fitzwilliam), Reynolds Hole, Etoile de Lyon, Maurice Bernardin, Marie Cointet, Boieldieu, and Alphonse Dumesnil. Mr. R. E. West, who gained the second prize, had Ulrich Brunner, Victor Verdier, Captain Christy, Marquise de Castellane, François Michelon, Mad. Gabriel Luizet, Etienne Levet, Baronne de Rothschild, Comtesse d'Oxford, Duke of Edinburgh, Souvenir d'Elise, Eugène Fürst, Alfred Colomb, La France, Violette Bouyer, Xavier Olibo, Catherine Mermet, Henri Ledechaux, Merveille de Lyon, A. K. Williams, Marie Van Houtte, and Le Havre. In the class for twelve Mr. R. E. West was first with Victor Verdier, Madame Gabriel Luizet, Barthelemy Joubert, Her Majesty, Alfred Colomb, Etienne Levet, Ulrich Brunner, Marie Van Houtte, Jules Finger, A. K. Williams, La France, and Baronne de Rothschild. Mr. B. R. Cant was second with Lady Mary Fitzwilliam, Alphonse Dumesnil, Alphonse Souperet, Marguerite de St. Amand, Xavier Olibo, Mons. Noman, Marie Baumann, Gabriel Luizet, Duchesse de Vallombrosa, Reynolds Hole, Ulrich Brunner, and Duke of Edinburgh. The competition for twelve Teas was a very close one, and ultimately it was decided to place Mr. B. R. Cant and Messrs. Paul & Son equal firsts. Mr. Cant's flowers were Souvenir d'Elise, Madame Lambard, Hon. E. Giffard, Niphetos, Bouquet d'Or, Catherine Mermet, Devoniansis, Madame de Watteville, Madame Cusin, Madame Bravy, Souvenir d'un Ami, and Maréchal Niel. Messrs. Paul & Son's flowers were Alba Rosea, Sunset, Souvenir d'Elise, Jean

Ducher, Madame Cusin, Etoile de Lyon, Niphotos, Maréchal Niel, Madame de Watteville, Comtesse de Nadaillac, Hon. Edith Giffard, and Francisca Kruger.

The day was a brilliant one, and the tent very destructive to the staying powers of the Roses.—D., Deal.

#### TWICKENHAM.—JULY 6TH.

FEW of the districts around London can equal Twickenham in its historical interest, not on account of the great events that have there occurred, but from the number of celebrities who have resided in its vicinity. Pleasantly situated on the right bank of the Thames a short distance above Richmond, it long ago became famous as an agreeable retreat for the wealthy and literary, but in recent years it has undergone considerable changes; the builder has been busy, and many of the old landmarks have disappeared, though it still retains some of its former charms. Perhaps one of the most noted places was Pope's Villa, which during the life of the poet Alexander Pope was the resort of the most distinguished people of his age. The villa itself has long since disappeared, and the grotto if it still exists, but has lost all that characterised it in the time of its designer. There are some remains of the garden in which the poet took so much pride, but his Willow has been lost, and little remains in the way of mementos. Another riverside mansion, near by which, a hundred years ago, was the residence of Earl Poulett, and still bears the title of Poulett Lodge, is more interesting for its present history than the past. It is now occupied by Mrs. Meek, and the gardens during the life of the late J. E. Meek, Esq., and under the management of Mr. Bates, gained more than local fame, the products, both plants, fruits, and vegetables, having won honours at many exhibitions during recent years. Nearly opposite to this was a garden which early in the present century was well known to horticulturists and botanists as the Twickenham Botanic Garden. It was the residence of Isaac Swainson, Esq., who amassed a considerable fortune by the sale of Develno's Veg table Syrup. He was the brother of William Swainson, an eminent naturalist, and devoted his garden mainly to a collection of hardy plants, which became one of the largest in cultivation, under the charge of Mr. Robert Castle, and is repeatedly mentioned in the early volumes of "London's Gardeners' Magazine," several plants from it being also depicted in the "Botanical Magazine" during the time that work was edited by Dr. John Sims. The whole collection was swept away many years ago, and the place is unknown except to a few veterans who can carry their memory back for half a century. Strawberry Hill, the residence of Horace Walpole, a short distance from there, is full of historical interest, to do justice to which a volume would be required. The residence of Mr. Twining, in another portion of the town, was at one time celebrated for the museum of economic products it contained, but which was totally destroyed by fire, the loss being estimated at £10,000. Cambridge House is of some historical interest, and, while occupied by the late Lady Chichester, the gardens, under the care of Mr. Munro, became well known to horticulturists in this and neighbouring districts. Marble Hill is another celebrated establishment, formerly the residence of the Countess of Suffolk. Orleans House was for a number of years the residence of Louis Philippe and other members of the Orleans family; subsequently it passed into the occupation of the Orleans Club, and is now the property of W. Cunard, Esq.

The Twickenham Horticultural Society held their eighteenth exhibition in the delightful grounds of the last-named establishment on Wednesday last, when four large marquees were devoted to the competing and non-competing exhibits. The quality was very satisfactory throughout, the arrangements were well conducted, and the Committee, with their Hon. Sec., J. J. G. Pugh, Esq., may be congratulated on their success; Mr. Bates deserving especial praise for his energy in superintendence.

In the specimen plant classes there was not a large competition. Messrs. Jackson & Son and Mr. Parsons led with stove and greenhouse plants. Tuberos Begonias from Mr. Little and Gloxinias from Mr. Parsons were good. Messrs. Hooper & Co., Twickenham, had the only group in the chief class, gaining the leading honours with a charming arrangement. Mr. Fellsell was first with a group of plants arranged for effect, followed by Messrs. Parsons, Buckland, and J. Street. For a stand of flowers, Mr. A. Ayres, Sandycombe Road, East Twickenham, was first with a light tasteful arrangement, followed by Mr. T. W. Alexander. Mrs. Stevens had the best button-holes, followed by Miss Little. Miss Laming, Miss G. Gardner, Miss Poupert, Mrs. Griffiths and Miss Lolian Cobbett also showed well in other classes. Stands of flowers, baskets of Roses, bouquets, &c., were well shown; cut Roses being also fresh and good, especially those from J. P. Kitchin, Esq. (gardener, Mr. C. Warwick).

With black Grapes, Messrs. W. & E. Wells (gardener, Mr. G. Thompson), Sir H. Thompson (gardener, Mr. G. H. Hookings), and T. Twining, Esq. (gardener, Mr. Parsons), were the prizetakers in that order; Mr. Hookings leading with white Grapes, good examples of Foster's Seedling; Messrs. Thompson and Hookings showing Peaches, and the latter had the best Melon Longleaf Perfection. Six fine Melons from Sir Henry Thompson were highly commended, as also were some magnificent Sir Joseph Paxton Strawberries from Mr. R. Clarke, Pope's Grove. Strawberries were also well represented in the class for one dish.

Of the non-competing exhibits, especially fine were the groups of plants, a good collection of Orchids from H. Little, Esq., Twickenham (gardener, Mr. F. Hill), being highly commended, and cultural certificate awarded. Fine groups were also contributed by Mr. Laing, Twickenham. A superb group from Messrs. Jackson & Son, Kingston, was highly commended. Mr. H. Little had a group of Pelargoniums, and Mr. W. Gordon a group of Lilies and Orchids. Messrs. J. Veitch & Sons, Chelsea, had six boxes of handsome Rose blooms (very highly commended).

A group of Cockscombs from Mrs. Meek, Poulett Lodge, Twickenham (gardener, Mr. W. Bates), comprised some well-grown plants with large richly coloured heads; they were highly commended. Mr. Ponpart had a collection of vegetables, and Mr. W. Taylor Roses and fruits, which were similarly recognised. There were many other meritorious exhibits which cannot be noticed now, especially table plants, with foliage plants from Messrs. Hooper & Co., who contributed well to the attraction of the Show, Mr. Little also assisting materially from his collections. The Judges were Mr. W. Smythe, Basing Park Gardens, Alton, Hants, and Mr. Lewis Castle.

#### PEACHES AND NECTARINES OUT OF DOORS.

ACCORDING to my ideas of good culture, most of the operations connected with Peach culture should be completed now. How can success be expected if the trees are left smothered with unnecessary growth until a late period? and how can anyone expect well-ripened wood if such be the case? One of the most important practices, however, is the pinching in due time of gross shoots. This can scarcely be done too early: they need not be more than 4 inches in length when this is performed. This practice is equally applicable to young trees or those in full bearing. Some persons have affirmed that there is no need for pinching when the trees bear well; but this is not correct. Of course we do not expect much gross wood from trees performing hard duty; nevertheless they are still, if healthy, liable to produce such, and should be handled accordingly. Indeed, in the latter case the practice has a double effect, which is scarcely the case in young trees; it concerns the fruit of the present year quite as much as the welfare of the trees in future years.

As I consider it indispensable that every amateur gardener should well understand the mode in which this practice influences the trees I will endeavour to explain it. Young Peach trees are very apt to produce unequal wood; one or more riotous shoots not infrequently threaten to destroy the balance of the whole tree. Of course it will be here understood that what befits the Peach applies equally to the Nectarine. Now, the pinching back gross shoots in this case simply tends to throw part of the overweening power of these robbers—or rather monopolisers—into the inferior shoots, or those which do not assume so much consequence. This gardeners term equalising the sap, or, in other words, sustaining a due proportion between the various members of which the tree above ground is composed.

In the case of pinching, as applied to trees in bearing, we have an extra feature to record and explain. Those who are in the least conversant with the habits of the Peach and Nectarine will have frequently observed that very commonly a tendency exists in the tree to produce coarse "breast shoots"—shoots springing with more luxuriance half-way up the branches than at the extremities. This carries a very anomalous appearance to those who have not spent much time, or exercised much close observation as to the mode in which Nature works. The fact is that under such circumstances one or more causes may be adduced to account for it. The chief, however, seems to be that the upper portion or extremity in trees of any age and bearing habits becomes much robbed of its sap by certain demands consequent on bearing. As a necessary consequence of the parts becoming drier, a sort of contraction or shrinking of the vessels takes place, and thus less facility in receiving the ascending fluids, and, indeed, of reciprocating with the root and other portions of the tree. But the root having acquired power will not long be baffled; absorption proceeds, and the hitherto untaxed portions of the lower parts of the tree receive more life; those which were inferior speedily evince a desire to take a lower position, and hence the sudden, impulsive, and somewhat unexpected movement which occurs as to the matter in hand.

It so happens that in such cases, whatever tends to arrest the ascending sap before it can reach freely the extremities of the branches, tends in a like degree to rob the fruit at the extreme portion of their proper share of nourishment, and also to lower the energies of the branches in that quarter; hence the reason for so often "cutting back" in Peaches—sometimes whole branches.

Here I must observe, that in this, as in most other matters, a certain amount of caution is necessary. There are cases in which it is desirable to cover naked walls as speedily as possible. Here the pinching must be modified according to circumstances, having regard to the extent of walling to be covered. In such cases the luxuriant shoots may be left until about a foot in length before they are pinched. This will bring them to the end of June; and if pinched about that time, two pairs of side or lateral shoots may be counted on from the side of each gross shoot. These may be suffered to ramble until 9 inches in length, when their heads should be pinched, and they will ripen tolerably well, and may, in the succeeding training season, be laid in as permanent wood. I do not think that under any circumstances it is expedient to attempt to gain more than this in one season; but it may be here observed, that the gross shoot will produce another leader besides the two pairs at the sides; this may be allowed to ramble another foot, and then be pinched. Thus it will be seen that one gross shoot, properly handled, may be made to cover a considerable amount of wall in one season.

The disbudding, as it is termed, will have been looked well to, doubtless, by this time; and I recommend that a final handling of this kind be carried out in the end of June or early in July. My practice is to remove every shoot not required for the ensuing year. Of course, it is difficult to determine on every one; but I approach this principle as near as I can. Whenever any doubt exists in the mind of the operator as to whether a certain shoot or shoots should be removed, such may at once be retained, simply pinching off the point. At that period, when the fruit commences the last swelling towards ripening, say the last week in July, I commence pinching the wood in general. But this is not everybody's practice. Be that as it may, I have found immense benefit from it; indeed, how could it be otherwise? This pinching is best done at thrice; and if we say the first at the end of July, the second in the middle of August, and the third in the first week of September, we shall be as near the point, according to my idea of principles, as possible. I go over first and pinch all the very strongest shoots, be they where they may; those, of course, are not what I before



termed the gross shoots; they were pinched or disbudded long before; they are the next in order as to strength. The second operation takes hold of a second series, and the third is of a similar character, only it may be noted that the second is a much lighter duty than the first, and the third much lighter than the second. One thing must here be observed; I never pinch any shoots that are considered too weak, especially those in an inferior position towards the bottom of the trees; these are allowed to ramble to the end of the season unmolested.—N. E. R.

### TREES IN PARIS.

TREES in London are by no means so plentiful as they should be and it is only within the last year or two that any steps have been taken to plant the various spaces with suitable trees and shrubs. In Paris, however, says a correspondent of a daily paper, the trees have long been the pride and delight of natives and the wonder and admiration of foreigners and provincials. In no other city in the world is there to be seen such a display of arboreal verdure. It meets the eye in every direction, and in some parts of the city even lingers long after autumn has begun to leave the traces of its fiery fingers on the foliage of the year. In the more opulent portions of the city the tree foliage has a full fresh look, even in midsummer, and on the outer boulevards, where inferior growths are used, there is a wealth of greenness which often compensates for grimy surroundings. The cause of the freshness of the Paris trees is not far to seek. Around the base of the most stunted plant there is always a circular pit, not very deep, and covered with iron bars, which look like the spokes of a wheel. By means of this pit the trees receive refreshing moisture, and their roots have what may be termed stretching-room. But independently of these precautions the trees are well looked after by the city authorities, whose gardeners watch and tend them with jealous care. One of these horticultural caretakers gives an interesting account of arboriculture in the metropolis. There were comparatively few trees in Paris before the Exhibition of 1855, and it was only at that period that the ædiles began seriously to think of planning those shady nooks and corners which now relieve the stucco, and the general monotony of metropolitan buildings. Nurseries were established in various places. In the Bois de Boulogne, near the Longchamps racecourse, was located a kind of hospital for sick trees. In the sandy soil near Auteuil were planted Pines and resinous shrubs; at Vincennes, and also at Passy, were cultivated ornamental or blossoming trees: while at Petit Bry, on the banks of the Marne, there was a special establishment devoted to the raising of trees intended to decorate the great highways which had been designed by the architectural invention of Baron Haussmann and the political exigencies of Napoleon III. The number of trees reared for the boulevards exceeds 100,000. They are usually Planes, Chestnuts, Elms, Poplars, and Sycamores, and their transplantation to Paris costs about £5 for each tree. The pearl of all the gardens in Paris is, of course, the Parc Monceau, with its wealth of Palms and Eucalyptus trees, its Banana from Abyssinia, and its tasteful parterres.

### ROSE SHOW FIXTURES.

July 7th, *Bath, *Farnham, *Farnham, *Ipswich, Malvern, *Reigate, and *Winchester.	July 15th, *Helsburgh, *Hereford, and Hull.
„ 8th, *Hitchin and *Maidstone	„ 16th, *New Brighton.
„ 9th, Crystal Palace.	„ 18th, *Christleton.
„ 12th, *Brockham, *Diss, and *Oxford.	„ 19th, *Leek.
„ 13th, *Edinburgh (N.R.S.).	„ 20th, *Birkenhead.
„ 14th, Alexandra Palace, Birmingham and Harleston.	„ 21st, Carlton - in - Lindricks (Notts) and Salterhebble (Yorks).
	„ 22nd, Manchester
	„ 23rd, *Ulverstone.

Those exhibitions which are held by the National Rose Society, or by Societies affiliated with it, are distinguished by an asterisk. In the above list there is one show extending over three days at the Alexandra Palace. In each of these cases the date of the first day's exhibition only is given. No less than six fixtures have been altered since my last list appeared at the end of March—viz., Brockham, Crystal Palace, Hereford, Hitchin, Christleton, and Reigate.

The clashing of fixtures is much to be regretted, but still more serious is, I think, the practice of altering fixtures which have been once definitely decided upon and made generally known.—EDWARD MAWLEY, *Rosebank, Berkhamsted, Herts.*



### HARDY FRUIT GARDEN.

THE APPLE CROP.—There is every prospect of an exceptionally good crop of Apples being obtained, though in many districts the trees already give signs of suffering from drought. Observant cultivators will have already noted that trees which bore heavily last year are in many instances very thinly cropped this season. They flowered as freely as the rest, but the blooms were weakly, and have all, or nearly all, fallen

This points plainly to the need of severe thinning in the case of all restricted trees, and the sooner this is done the better. Only the very finest fruit will fetch good prices, and if the thinning is done in no half-hearted manner, not only will much finer fruit be secured, but the trees will not have been unduly exhausted in the vain attempt to perfect all that set. Clusters of fruit afford good harbour for maggots, and all that are accessible ought, therefore, to be reduced to a single fruit. Cordon, espalier, bush, and pyramidal trained trees should also have all lateral growths not required for furnishing the trees shortened back to the fourth or fifth joint, preventing the waste of vigour, and admitting more light and air to the trees. Any well placed shoots may well be left untouched both now and at the winter pruning, and these will most probably be covered with fruit spurs in less than two years. Some seasons well ripened and unpruned young growths will flower the following season. We have plenty such fruiting this summer. Fruit trees on heavy land are gradually recovering their original profitable state, hot and dry weather really suiting them.

SUMMER-PRUNING WALL TREES.—If the lateral growth of these was not duly thinned out and stopped when it could be done with the finger and thumb, it ought to be done at once, and with the knife. All shoots not needed for furnishing vacant wall space ought to be thinned, and those left cut back to within 4 inches of the old wood. The leading growths are now sufficiently matured to be safely nailed or tied in, and if left much longer some will break rather than fit closely to the walls. The strong central growth of the espalier or horizontally trained trees will now in early localities be fit for shortening back to about 12 inches of its base. From the breaks resulting select the three best placed, one for continuing the lead, and the others for side branches, in this manner securing two tiers of branches in one season. Only in the case of vigorous trees in a sunny position should this plan be adopted. Vigorous Peach and Apricot trees stopped early will soon require fresh attention, otherwise the increased number of young shoots will quite smother the fruit. Peaches are extra plentiful. In very few instances will they be sufficiently thinned out, and overcropped trees will make but little growth requiring removal; in fact, unless plenty of water and liquid manure be given the trees, they will come to a standstill as far as wood growth is concerned.

INSECT PESTS.—A few weeks ago these were not so plentiful as usual, but the case is very different now, thrips, aphides of sorts, and red spider being most abundant. Nor are they easily exterminated. The first proceeding should be to prune and nail the trees as just advised, this removing much of the green and black fly from the Cherries and Plums, and rendering it much easier to clean the rest of the tree. Clear water applied forcibly, and rather often, with a garden engine, if available, usually effectively clears the trees of nearly all the insects named, and if this fails, try a weak dose of tobacco water or a solution of quassia chips and softsoap. Tobacco water can either be purchased from the vendors of horticultural requisites, or be made from shag tobacco or tobacco paper. About 4 ozs. of the former, or a pound of the paper or rag soaked in a gallon of hot water, in which has been dissolved 4 ozs. of softsoap, will make a powerful insecticide, and which may be diluted with soft water according to its tested strength. The quassia chips, at the rate of 6 ozs. to the gallon of water, should be boiled for half an hour, 6 ozs. of softsoap being added at the last. This solution, after being strained from the chips, may be stored and used at the rate of a 5-inch potful to three gallons of syringing water. In this and other cases it is best to test the strength or efficacy of the insecticides, and mix accordingly. The fruit being well advanced, it is advisable to freely syringe or engine the trees on the mornings following the evening application of insecticides. Red spider will not be much disturbed by any kind of insecticide, a coating of sulphur only checking it, and as this ought not to be applied till the fruit is off the trees, plenty of moisture at the roots and frequent syringings will keep the trees in good health.

### FRUIT FORCING.

PINES.—Preparations should be made for starting the suckers, which will soon be fit to be taken from the plants which formed the early section of summer fruiterers, the necessary provision being made at once, so that the plants may have the benefit of the undiminished solar heat in developing growth for as long a time as possible. The means essential are a fermenting bed in a low damp house or pit, and the heat of it in a steady state of about 90° at 6 inches from the surface, but a few degrees higher, or 95°, may be allowed at the start, care being taken that it is not exceeded. The plants or suckers should be taken from the parent plants and then placed directly into 5 or 7-inch pots according to the size of the plants or suckers, and be watered once in order to settle the soil about them. Good fibrous loam torn up by hand without any admixture is the most suitable compost, which should be firmly embedded in the pot, which will tend to cause speedier root-action and sturdier and more satisfactory growth in the plants. For a week or ten days the house or pit should be kept rather close and moist; shade effectually and give but little air, sprinkling through a fine syringe once or twice a day according to external influences. As soon as growth takes place more ventilation with less shade is desirable, which must be proceeded with gradually until the growth is well decided and the plants are inured to the sun, when ordinary treatment should be given. Once the plants are started they must not be allowed to become root-bound, but the growth accelerated as far as is consistent with a sturdy growth; consequently there must not be any delay in shifting into the largest pots immediately the roots have taken firm hold of the soil and before they become matted together at the sides of the pots, which for Queens and Black Jamaica may be 10-inch, and for other sorts 11 or 12-inch, using

fibrous loam, but more lumpy than for suckers, adding a sprinkling of half-inch bones, and to prevent worms entering the pots a handful of soot or wood ashes may be sprinkled over the drainage.

**CUCUMBERS.**—A few seeds may now be sown for late summer and early autumn fruiting. They will germinate, and the seedlings be fit to plant out in about a month. Attention must be given to plants in bearing, thinning the exhausted growths and foliage, laying in young bearing wood, stopping one joint beyond the fruit, and earthing the roots periodically. Copious supplies of liquid manure will be required about twice a week, or as may be necessary, but avoid applying it too strong, syringing at closing time, and maintaining a good moisture all day by sprinkling every available surface as necessary, but more frequently in hot weather than when dull. Do not overcrop young plants, and do not allow the fruits to hang too long, as upon attention to this depends in a measure a good and continuous supply.

**FIGS.**—The first crop in the early house is gathered, and more moisture in the atmosphere will be desirable, therefore resume syringing the trees twice daily, and sprinkling the house as advised before the fruit commences colouring. Thinning the fruit, if plentiful, must be free, reserving those which are nearest the base of the shoots. Tie in the growths to the trellis as they advance, stopping or removing such as are not required, regulating those retained, so that they may receive the beneficial effects of light and air to mature them perfectly. Do not allow the trees to suffer by want of water; those in pots or planted out in borders of limited extent will require water frequently, affording on every occasion some stimulating food—such as guano or other manure. Where crops are ripening constantly maintain a free circulation of dry warm air, which is essential to the Figs ripening perfectly. Trees in pots required for early forcing must not be neglected in syringing occasionally, attending with regularity to the watering, supplying liquid manure.

**MELONS.**—It is important that the late plants be planted out without delay, especially where the means of affording artificial heat is confined to fermenting materials. Whether grown in pits or frames a sufficiency of fermenting materials should be used to raise a bottom heat of about 90°, so as to start the plants quickly. In houses as the crops are cleared, the plants, if exhausted, should be removed, and preparations made for a fresh start at the earliest opportunity; but if the plants are in good health it is folly to root them out, as they will come into bearing again much sooner than young plants, and are in every way more tractable; indeed if the plants are not overcropped, do not suffer for water at the roots, and if the foliage is kept healthy they will continue bearing as late as it is desirable. When the crop is cut the plants should be divested of most of the old or damaged leaves, fresh growths being encouraged in the place of any exhausted, which should be cut away. The surface of the bed should be loosened, and the loose surface soil removed, applying a couple of inches in depth of fresh loam, giving a good watering, and when growth is taking place afford a free application of liquid manure, and treat as for former crops. When Melons are grown upon the continuous system it is well to note that the laterals will grow freely and show fruit abundantly after a few joints of growth. The flowers after being fertilised will set and the fruits will swell freely, so that sufficient moisture only need be accorded to maintain the plants in continuous bearing. Attend to stopping, thinning, tying, or otherwise regulating the shoots, not allowing pressure of work in other departments to interfere with this, or the results will be detrimental. Successional plants should be earthed up as soon as the roots show at the sides of the hillocks, making the soil firm, being careful that the plants do not suffer by want of water, and, on the other hand, are not too wet. To plants swelling their fruits supply liquid manure, but be careful not to give too much. Maintain a bottom heat of 80° to 85°, and afford a moist atmosphere to growing crops, syringing freely, excepting when the fruit is setting or ripening, being careful not to allow one or two fruit to take the lead, but have them all as nearly as possible of one size on a plant.

#### PLANT HOUSES.

**Ericas.**—When these plants are used during their flowering season in the conservatory, be careful not to crowd other plants about them. Serious damage is frequently done to hardwood varieties during the time they occupy such places; crowding so as to exclude light from their foliage means destruction in a very short time. First the leaves turn brown and eventually fall, which not only gives a severe check to the roots, but renders the plants unsightly. Light and air are essential features in the culture of these plants. After flowering nothing is gained by any attempt to push them into growth. After the fading flowers have been removed the plants should have cool airy treatment, gradually exposing them to full light and air stood on ashes in an open aspect outside. The full force of the sun shining on their branches will not injure them, but the pots must be protected, or the silk-like roots of the plants will be severely injured. Varieties that it is necessary to retard may be kept in a northern aspect where they can be kept perfectly cool. Young stock that it is intended to grow on as rapidly as possible may have any shoots that are taking the lead pinched so as to induce the formation of a duly proportioned plant. If well rooted in the pots in which they were placed in February last, they may be transferred into others 2 inches larger. Use a compost of fibry peat to which is added a liberal dash of sand. In potting, drain well and liberally, be careful not to disturb the old ball, and press the new soil firmly about the roots. The collar of the plant must not be buried deeper than has been previously the case. Plenty of room should be left in the pots to hold sufficient water to soak the whole ball. Water

carefully, but do not allow them to become dust dry or suffer in the least by an insufficient supply, or serious injury will certainly result.

**Softwooded Ericas.**—These are much better outside fully exposed to the sun than crowded closely together in frames. The same provision should be made for the protection of their pots, or if the plants are in from 5 to 7 inch pots the outer rows may be plunged, or partially so, and these, if arranged in beds not too far apart, will afford ample shade to the pots in which the inner rows of plants are growing. Syringe liberally twice daily, and be careful that the ashes or other material upon which they stand is kept moist. Epacris that have made good growth may be placed outside to harden and ripen; in fact, the treatment advised for softwooded Heaths will suit them well. Later plants may still be encouraged in cold frames.

**Azaleas.**—Early varieties will by this time have set their flower buds. Plants in this condition cannot be retained under glass during the remainder of the season, or they will flower early in September when they are not wanted. Gradually harden them and remove them to cool outside quarters. If exposed suddenly to the full force of the sun their foliage will be very much browned, but if stood in a light partially shaded place they will have ample time to thoroughly ripen their wood, and at the same time their flower buds will be retarded. Give all the air possible day and night to those that have completed their growth and about to form flower buds. This must be done gradually at first if the plants have been subjected to a close moist atmosphere. Until it is certain that flower buds are forming maintain a slightly drier atmosphere, but do not diminish the supply of water at their roots. Watch carefully for thrips, for if any exist in the house they are certain to attack the plants during the time the syringe is withheld. Water freely, and syringe liberally those that are in active growth. Shade them from the sun, and close the house early in the afternoon while the sun is upon it.

**Celosias.**—Those intended for winter decoration should now be well established in 3-inch pots; they must not be allowed to become root-bound before they are placed into 5 and 6-inch pots. Place a stake to each plant, then grow under cool airy treatment after they are once rooting freely in the new soil. When these plants are required for winter decoration they must be developed under hardier conditions than when required for the summer. Plants that are in a backward state and require pushing forward under close treatment, more especially in their later stages, are very liable to damp off during the dull days of winter. To avoid such consequences press the soil firmly into the pots, and induce the plants by giving air abundantly to make a dwarf sturdy growth.

**Cyclamens.**—The earliest plants should now be placed in 6-inch pots and arranged on ashes in cold frames or in low light houses. Use for a compost good fibry loam three parts, and one part leaf mould and sand; one-seventh of cow manure may also be added. Keep the frame or house close for ten days or a fortnight, and then give plenty of air and only sufficient shade to break the strong rays of the sun. If over-shaded the foliage is drawn weakly and the plants are quickly ruined. Water carefully at first, but never allow them to become dry; syringe them heavily twice daily, and keep the material upon which they are standing moist. Give to later plants the same treatment until they are ready for their largest pots. Seed may now be sown in a pan in a warm house for the earliest supply of plants for another year.

**Camellias.**—Plants that were assisted early in the season to make their growth under the influence of heat and a close atmosphere will have completed it by this time. The main object to be attained is to prevent the plants starting into fresh growth, as, if they do, flowers will not be forthcoming. In order to avoid this maintain drier atmospheric conditions about the plants, at the same time do not allow them to suffer by insufficient water at their roots. Give air abundantly and admit more light to them. This will harden and ripen the wood, and the formation of flower buds will be certain. Without brown, hard well matured wood a good crop of fine flowers cannot be expected. As soon as the flower buds are visible the syringe may on all bright days be freely used, and a moister atmosphere given to the plants. Feeding with weak stimulants may also be resorted to, for in no stage do Camellias need assistance more in this matter than during the development of their flower buds. Directly the buds commence swelling syringe the plants thoroughly with petroleum and water, 1 oz. of the former to each gallon of the latter. This in addition to proving a stimulant will destroy any insect pests that are upon the plants, and cleanse the foliage from dirt; in fact, it imparts to the foliage a dark green glossy appearance, as if they had all been thoroughly sponged.

#### THE FLOWER GARDEN AND PLEASURE GROUND.

**Spring Bedding Plants.**—These during June usually experience rather rough treatment, nor is this greatly to be wondered at, seeing how much labour has, this season especially, to be expended on refilling the beds with their summer occupants. They must not long be laid in by the heels or neglected in any way, or many may not be available for next winter. All must have plenty of water, particularly those evergreens and Conifers that have small balls and roots. The latter if once allowed to become very dry can only be moistened and kept alive by soaking them in a tub or pail of water prior to replanting them in good light soil, or where they are to remain till wanted again. When it is necessary to lift Crocuses, Snowdrops, Hyacinths, Tulips, Narcissi, and Scillas, they ought for a time to be laid in the ground, and when the foliage is well ripened the bulbs may be taken up and stored in boxes of sand. A dry cool shed is the best place for keeping the bulbs, but they must be

protected from mice. All, however, are best left in the ground. Anemones ought not to be disturbed more than can possibly be avoided, but if they must be taken up, store them in boxes of sand directly after they are ripened. Ranunculuses are apt to either keep badly or to start prematurely when left in the ground. After the leaves have turned yellow the roots may safely be lifted, dried, and stored on dry shelves.

The various perennials used in the beds during the winter ought now to be attended to and largely increased, young plants in nearly every case being preferable to old and exhausted stock. *Ajuga reptans rubra*, an easily grown useful plant for the carpet beds, divides readily, and may be dibbled out at once in a cool place till wanted. *Alyssum saxatile* and varieties may frequently be split up, each division having a few roots attached, and dibbled out on a partially shaded border. Small pieces of healthy, sturdy growth may be pulled off with a heel and dibbled in thickly in a handlight or at the foot of a north wall. Any light sandy soil suits them, and they should be watered in and shaded from bright sunshine where necessary. Arabises to be pulled to pieces, and each division with or without roots be dibbled out firmly in good garden soil, watered in, and lightly shaded with branches of trees for a time. *Aubrietias* require exactly the same treatment. Daisies are often spoilt through being planted during the summer in a hot and dry position. A cool north border is the proper place for them, and now is the time to pull old plants to pieces and replant. *Euonymus radicans variegata*, a plant useful alike for winter and summer bedding, is propagated by means of cuttings in summer. They should be taken off about 4 inches in length, dibbled closely into a bed of fine sandy soil, and covered with handlights. Shade from bright sunshine, and give water whenever the soil is at all dry. Gentians ought not to be disturbed frequently, or they will flower indifferently. Always move them with a good ball of soil about the roots and divide the strongest clumps only. Plant in a good sunny position. *Hepaticas* transplant readily, and may also be freely divided. Replant firmly in good light ground, and keep them well supplied with water in dry weather. *Iberises* may be treated in every respect similar to the *Alyssum*. They are of somewhat slow growth, and good sized plants are most effective, being available for several seasons. *Myosotises* as a rule are raised from seed, this being sown early, or not later than the middle of June. The white and blue varieties of *Myosotis dissitiflora* are the most beautiful, and capital plants can be had by division of old stock, or small pieces may be pulled off and dibbled into handlights stood in a somewhat cool place. *Primulas* are quickly increased by division, it being possible to separate nearly every crown with roots to each. These divisions should be dibbled out at the foot of a north wall or other cool shady position, a rather rich or moisture-holding soil suiting them. *Saxifrages granulata flore-pleno*, *pyramidalis*, and *umbrosa* are as easily propagated as *Primulas*. The first-named is increased by division of its grain-like roots, and the others by dividing the crowns. Plant out in rows on good ground. *Violas* and *Pansies* that have been lifted, trimmed in, and laid in by the heels in good ground are now pushing up numerous young shoots, and may be freely divided. Plant out these divisions on well-manured ground, and when the growths are well advanced, or say early in August, take off a number of cuttings and insert either under handlights or at the foot of a cool wall.

## THE BEE-KEEPER.

### PRACTICAL BEE-KEEPING.

No. 14.

It is comparatively easy to work an apiary upon the swarming system of management, because when once a swarm has been located in its new home successfully only gross neglect will cause it to send out a swarm that season; while the old stock, after it has sent forth a cast, and that cast has been returned on the evening of the day it issued, will also give no further trouble that year. When once a stock has been allowed to gratify the swarming desire no anxiety need be again entertained about either stock or swarm, except to watch for and return the cast which is sure to issue on or about the ninth day from the issue of the swarm, unless supering arrangements are most culpably neglected.

Taking into consideration the length of the honey season it has been determined, let us say, to adopt the swarming system. This determination having been arrived at, great attention must be paid to one point of management. This point is to discover, if possible, about what time the Clover will begin to bloom in the district, because by this all our efforts must be guided. When this date has been ascertained every effort must be made to have

both swarms and stocks ready to work in supers by the time that the honey flow commences. The success or failure which attends these efforts will be the measure of success or failure to which we shall attain in our management.

In the majority of English counties the Clover will begin to bloom during the first week of June, I think, and therefore we may take the 7th of June as a day when every colony should be ready for supering, whatever the system of management may be. If it were possible to insure that both the swarm and the stock would be strong enough to work in supers during the first week in June, a greater result would ensue than when no increase is allowed, except for one heavy drawback in the fact that during the short honey glut not only would the bees have to collect the honey, but they would also have to build the comb and cells in which to store it, which, when a hive is managed on the non-swarming system, are always ready to receive the honey which the bees may be expected to gather during the height of the season; but where there is no honey to be collected in the month of May the bees cannot work in supers even in drawing out comb. Therefore I say it is more profitable in such a case to take an increase, feed the swarm, and, if necessary, the stock, gently, and have two colonies ready to do what they are able while the Clover is in bloom. If, however, combs can by any means be given to the stock and swarm the result will be far in excess of that obtained from a stock not allowed to swarm. When, therefore, an extractor is used, and there are at hand four or five tiers of frames filled with comb—not foundation—the swarming system is the one which should be adopted. These frames of comb can be used year after year for the same purpose, and it is therefore profitable to make a special effort to obtain them in the manner to be afterwards pointed out. If honey in the comb is required increase must be prevented in order to obtain supers of comb by the time when the great honey flow sets in, but these supers of comb can only be obtained when there is a fair supply of honey to be collected in May. I may be permitted to say here that I have read Mr. Simmins' "Original Non-Swarming System" with some interest, but fail to see many signs of originality in it, except perhaps in some trifling details. His system is simply a scarcely veiled return to eking and supering, a system carried out with success years ago. The whole question, then, of choosing between these systems depends upon the simple fact whether we are able to obtain frames of comb and supers of new white comb. If these can be obtained in an easy practical way the swarming system must be adopted. Frames of comb can generally be raised, supers of comb are obtained with difficulty. When extracted honey is required the swarming system may generally be adopted. When comb honey is required the non-swarming system must be adopted, unless the May honey flow is so small as to give no chance of the bees having an opportunity of drawing out comb ready for the June flow, when the swarming system should be the one followed, because the bees may be kept in health and vigour, and will be ready for supering if properly managed by the 7th of June, even when one swarm has been taken from every stock. If no stock has empty combs to fill, a swarm and the stock from which it has issued will collect more honey and seal it than an old stock from which no increase has been taken. In addition to this, when honey is scarce bees are very anxious to swarm, and it is difficult to restrain them.

By the 7th of June every swarm and stock must be



ready for supering, therefore every swarm should have issued not later than the 15th of May. A swarm hived on the 15th and assisted with a little syrup will be ready to work in supers on the 6th or 7th of June at the latest if the weather has been at all favourable and the swarm strong; while the old stock will, after sending out a cast, and this cast having been returned, be ready also to work in supers about ten days after the issue of the swarm, thus having a week or more to prepare for the great glut which we annually expect and often receive. As a matter of fact very few stocks are ready to yield a swarm on the 15th day of May. If a stock is ready to work in supers on the 1st May it will not swarm, generally speaking, before the 20th of that month, and such a swarm will miss the earliest days of the Clover honey flow. Here is the crux—The honey glut is so short, and the weather so precarious, that it is absolutely necessary to be prepared to take advantage of every fine day. What, then, are the conditions which make the swarming system sometimes more profitable than the non-swarming system? They are three:—

1. Where there is little honey in May.
2. When there is a Heather harvest expected.
3. When swarms can be obtained before the 15th May.

Again, in any case and under all circumstances the swarming system is most profitable when there is

1. A supply of frames filled with comb.
2. A supply of supers filled with new white comb.

The Heather harvest has not been considered at length because it will really not necessitate any great change in our arrangements, except under conditions which shall be fully explained at some future time. Now, it will be self-evident that if the honey glut begins later than the 7th of June the swarm may be allowed to issue later in proportion; if the glut commences earlier the swarm must also issue earlier too. It need hardly be added that in those districts where the harvest is principally from fruit bloom, &c., in May, and no Clover honey is expected, no increase must be allowed—at any rate, until after the honey season is at an end; when, if a Heather harvest is expected, the time between the two flows may be utilised in increasing the number of stocks.

For the success of the swarming system a careful autumn preparation is absolutely necessary, and any neglect in the preceding year will be the forerunner of failure in the succeeding spring. It may also be said that it is more natural to allow a stock to swarm, but great stress need not be laid upon this point, although it is not wise—unless there is a benefit to be gained—to thwart Nature gratuitously. More than one swarm should never be taken from any stock that is afterwards expected to yield a honey harvest; but every cast should be returned on the evening of the day of issue.

Three special advantages result from allowing swarms to issue. These are

1. The number of stocks is doubled at least.
2. Young queens are raised under the swarming impulse.
3. If permanent increase in the number of stocks is not desired, any stock can be strengthened by the addition of the bees of its swarm in autumn.

To some the first point would be a consideration; to others, however, who do not require such a permanent increase, and who are unable to sell their surplus stocks, it would offer no temptation of itself: but, as pointed out, the bees of these swarms can be utilised in autumn for strengthening the permanent stocks, and are thus a great advantage, and save the cost otherwise often incurred by

purchasing driven bees for the purpose. Young queens raised under the swarming impulse are very valuable, and this point is of considerable weight; unless the practice of giving young fertile queens, and thereby “lifting” the stocks, is adopted, when this advantage will be to some extent lost.

When, then, there is only a little flow of honey in May, or when there is a good flow of honey in May, if super bodies of frames filled with comb or supers filled with virgin comb can be obtained the swarming system should be adopted. In the former case it will give better results than the opposing system, because if neither has a supply of empty comb the stock and the swarm will do more work than the stock alone: in the latter case because, if sufficient empty comb can be obtained without keeping the bees busy working it in May, a stock and swarm will fill and seal more combs than a stock from which no swarm has been allowed to issue. When there is a good flow of honey in May, and there are no empty combs at hand, then it will be more profitable and more practical to prevent increase and to compel the stock to work out tier upon tier of comb ready to hold the surplus, which may confidently be expected about the 7th of June. These are my conclusions. I have endeavoured to state my reasons for arriving at such conclusions as concisely and clearly as possible. The subject is, however, intricate and difficult, but those who are aware of the many considerations to be kept in view in such a discussion of two opposing systems will be able to understand how hard it is to explain everything clearly, so that all may grasp the chief points to be considered without being biased in favour of or against either system by the personal predilections of the writer. No hard-and-fast rule can possibly be laid down as to the merits of the one system or the other; each one must endeavour to understand the salient points in both, take into consideration his peculiar circumstances, and then decide which system will most probably give the best results in his individual case.—FELIX.



All correspondence should be directed either to “THE EDITOR” or to “THE PUBLISHER.” Letters addressed to Dr. Hogg or members of the staff often remain unopened unavoidably. We request that no one will write privately to any of our correspondents, as doing so subjects them to unjustifiable trouble and expense.

Correspondents should not mix up on the same sheet questions relating to Gardening and those on Bee subjects, and should never send more than two or three questions at once. All articles intended for insertion should be written on one side of the paper only. We cannot reply to questions through the post, and we do not undertake to return rejected communications.

**LATE INQUIRIES.**—It is necessary to again remind correspondents that letters arriving on WEDNESDAY MORNING cannot be answered in the “next issue,” which is then far advanced for press.

**Cinerarias (A. B.).**—The leaf sent is tunneled with a small maggot—a leaf miner. It is similar in its action to the Celery fly, and hatches from eggs deposited in the l-aves by a small fly. When the maggots take possession of the leaves we know of no remedy for their extirpation without injuring the plants. If any of our readers can send us the particulars of any method that has proved effectual in banishing the pest we will readily publish them.

**Gloxinia Leaves Disfigured (F. J.).**—The leaves are spotted and discoloured on the margin, evidently scorched by the sun acting powerfully

upon them whilst wet. They have also evidently suffered from a deficiency of nutriment both at the roots and in the atmosphere. The remedy for the former is to feed with liquid manure, and to maintain a moister and more genial condition of the atmosphere by damping available surfaces at least twice a day, and admitting air moderately so as not to dry the air too suddenly and so cripple the foliage. Get the plants into better health, and they will then have finer foliage and flowers. Your letter was insufficiently stamped, and it is a wonder it was taken in by our receiving clerk; perhaps you would like to send him the penny he paid as extra postage.

**Pruning Passion Flower (R. W.).**—You may cut back the laterals that have flowered, and it is possible, if the plant is strong and its position in the conservatory light, that fresh growths would push that might flower later in the season, but not in six weeks. The shortening of those growths would, moreover, admit light and air the more freely to the growths not cut back, and these would ripen the better. Overcrowding should be avoided, and any parts of the plant may be removed to prevent a close thicket of growth, that being neither agreeable in appearance nor good for the plant; but a general system of close pruning must not be carried out till late in the autumn.

**Morello Cherries not Stoning (M. L. G.).**—The tree is over-luxuriant, so much so that the wood does not ripen, the buds not being thoroughly perfected in embryo. We advise your taking out a trench in early autumn or in late summer, when the growth is complete and the wood becoming rather firm, at a distance from the stem of one-half the radius the branches extend, and down so as to detach all roots outside the radius, and fill in the trench after mixing a fourth of old mortar rubbish with the soil, making it quite firm. The operation is best done in cloudy weather, for if bright the detaching of the roots may cause the foliage to flag, in which case shade lightly from powerful sun, and syringe in the evening and early morning. Unless the soil becomes very dry no water should be given, but the foliage must not suffer by the want of it. Early in November remove the surface soil down to the roots, and some of it from amongst them, add a fourth of lime rubbish, and return, covering the roots 3 or 4 inches deep. Mulch with 2 or 3 inches thickness of short litter about 1 foot further than the roots extend.

**The Green Gage Plum (G. O. F.).**—There is no doubt that this is a very old Plum. We have nothing to add to the history of it as given in the "Fruit Manual":—"This universally known and highly esteemed fruit has been longer in this country than is generally supposed. It is said to have been introduced at the beginning of the last century by Sir Thomas Gage of Hengrave Hall, near Bury St. Edmunds, who procured it from his brother, the Rev. John Gage, a Roman Catholic priest, then resident in Paris. In course of time it became known as the Green Gage Plum. In France, although it has many names, that by which it is best known is Grosse Reine Claude, to distinguish it from a smaller and much inferior Plum called Reine Claude Petite. The Green Gage is supposed to be a native of Greece, and to have been introduced at an early period into Italy, where it is called Verdochia. From Italy it passed into France, during the reign of Francis I., and was named in honour of his consort Queen Claude; but it does not appear to have been much known or extensively cultivated for a considerable period subsequent to this, for neither Champier, Olivier de Serres, Vantier, nor any of the early French writers on husbandry and gardening, seem to have been acquainted with it. Probably, about the same time that it was introduced into France, or shortly afterwards, it found its way into England, where it became more rapidly known, and the name under which it was received was not the new appellation which it obtained in France, but its original Italian name of Verdochia, from which we may infer that it was brought direct from Italy. It is mentioned by Parkinson, in 1629, under the name of Verdoch, and, from the way he speaks of it, seems to have been not at all new, nor even rare. It is also enumerated by Leonard Meager in the 'list of fruit which I had of my very loving friend, Captain Gurle, dwelling at the Great Nursery between Spitalfields and Whitechappel,' and is there called Verdocha. Even so late as the middle of the last century, after it had been re-introduced, and extensively grown under the name of Green Gage, it continued to bear its original title, and to be regarded as a distinct sort from the Green Gage. Hitt tries to describe the distinction; but as he tries also to show that the Reine Claude is also distinct from the Green Gage, his authority cannot be taken for more than it is worth; a remark which may safely be applied to all our pomologists of the last century. Miller also laboured under the same misapprehension as Hitt, for in his Dictionary he says, speaking of the Grosse Reine Claude, 'this Plum is confounded by most people in England by the name of Green Gage.' We have seen, therefore, that the generally received opinion that this valuable Plum was first introduced to this country by the Gage family is incorrect, but that it must have existed for considerably upwards of a century, at least, before the period which is generally given as the date of its introduction."

**Names of Plants.**—We only undertake to name species of plants, not varieties that have originated from seed and termed florists' flowers. Flowering specimens are necessary of flowering plants, and Fern fronds should bear spores. Specimens should arrive in a fresh state in firm boxes: Slightly damp moss or soft green leaves form the best packing, dry cotton wool the worst. Not more than six specimens can be named at once. (A. R. C., Liverpool).—Epidendrum tovarense. The variety of Cattleya Mendelii is an excellent one. (J. J. Woolton).—It is a very handsome variety of Odontoglossum crispum. We have seen some similar in several large collections, but not named; such well-formed flowers are always much prized. (W. B. S.).—The specimens arrived in such bad condition that it is impossible to recognise them. Correspondents who wish their plants named should take especial care in packing them at this time of year, and not simply enclose them in an envelope. (E. S.).—It is perhaps Lilium umbellatum, but we do not undertake to name plants from a single petal and an imperfect leaf.

**COVENT GARDEN MARKET.—JULY 6TH.**

THE bulk of the outdoor Strawberries now reaching us prices of all sorts of indoor fruit are lower, Grapes especially being affected. Business quieter.

**VEGETABLES.**

	s. d.	s. d.		s. d.	s. d.
Artichokes, dozen ..	1 0	2 0	Lettuce, dozen ..	0 3	0 0
Asparagus, bundle ..	1 6	4 0	Mushrooms, punnet ..	0 6	1 0
Beans, Kidney, per lb. ..	1 3	0 0	Mustard and Cress, punt.	0 2	0 6
Beet, Red, dozen ..	1 0	2 0	Onions, bunch ..	0 3	0 6
Broccoli, bundle ..	0 0	0 0	Parsley, dozen bunches ..	2 0	3 0
Brussels Sprouts, 1/2 sieve	0 0	0 0	Parsnips, dozen ..	1 0	0 0
Cabbage, dozen ..	1 6	0 0	Potatoes, per cwt. ..	4 0	5 0
Capsicums, per 100 ..	1 6	2 0	" Kidney, per cwt.	4 0	0 0
Carrots, bunch ..	0 4	0 0	Rhubarb, bundle ..	0 2	0 0
Cauliflowers, dozen ..	3 0	4 0	Salsify, bundle ..	1 0	1 6
Celery, bundle ..	1 6	2 0	Scorzoneria, bundle ..	1 6	0 0
Coleworts, doz. bunches ..	2 0	4 0	Seakale, basket ..	0 0	0 0
Cucumbers, each ..	0 4	0 6	Sballots, per lb. ..	0 5	0 0
Endive, dozen ..	1 0	2 0	Spinach, bushel ..	3 0	4 0
Herbs, bunch ..	0 2	0 0	Tomatoes, per lb. ..	0 6	0 3
Leeks, bunch ..	0 3	0 4	Turnips, bunch ..	0 4	0 6

**FRUIT.**

	s. d.	s. d.		s. d.	s. d.
Apples, 1/2 sieve ..	0 0	0 0	Oranges, per 100 ..	6 0	12 0
Nova Scotia and			Peaches, dozen ..	4 0	12 0
Canada barre 10	0 13	0	Pears, dozen ..	0 0	0 0
Cherries, 1/2 sieve ..	5 0	6 0	Pine Apples, English,		
C. bs, 100 lbs. ..	0 0	0 0	per lb. ..	1 6	0 0
Figs, dozen ..	3 0	6 0	Plums, 1/2 sieve ..	0 0	0 0
Grapes, per lb. ..	1 6	2 6	St. Michael Pine, each	3 0	5 0
Lemons, case ..	10 0	15 0	Strawberries, per lb. ..	0 3	0 10
Melon, each ..	2 0	3 0			

**PLANTS IN POTS.**

	s. d.	s. d.		s. d.	s. d.
Aralia Sieboldi, dozen ..	6 0	12 0	Fuchsia, dozen ..	4 0	9 0
Arbutus (golden) dozen	6 0	9 0	Genista, dozen ..	0 0	0 0
" (common), dozen ..	0 0	0 0	Geranium (Ivy), dozen ..	4 0	6 0
Azalea, dozen ..	0 0	0 0	" Tricolor, dozen ..	3 0	6 0
Begonias, dozen ..	4 0	9 0	Hydrangea, dozen ..	9 0	12 0
Calceolaria, dozen ..	4 0	9 0	Lilies Valley, dozen ..	0 0	0 0
Cineraria, dozen ..	0 0	0 0	Lilium longiflorum, doz.	18 0	30 0
Creeping Jenny, dozen ..	3 0	4 0	Lobelia, dozen ..	3 0	5 0
Dracena terminalis, doz.	30 0	60 0	Marguerite Daisy, dozen	6 0	12 0
" viridis, dozen ..	12 0	24 0	Mignonne, dozen ..	4 0	9 0
Erica, various, dozen ..	18 0	30 0	Musk, dozen ..	2 0	6 0
Euonymus, in var., dozen	6 0	18 0	Myrtles, dozen ..	6 0	12 0
Evergreens, in var., dozen	6 0	24 0	Palms, in var., each ..	2 6	21 0
Ferns, in variety, dozen	4 0	18 0	Pelargoniums, dozen ..	6 0	15 0
Ficus elastica, each ..	1 6	7 0	" scarlet, doz.	3 0	9 0
Foliage Plants, var., each	2 0	10 0	Spiraea, dozen ..	6 0	12 0

**CUT FLOWERS.**

	s. d.	s. d.		s. d.	s. d.
Abutilons, 12 bunches ..	2 0	4 0	Marguerites, 12 bunches	2 0	6 0
Azucenas, 12 bunches ..	2 0	4 0	Mignonne, 12 bunches	2 0	4 0
Arm Lilies, 12 blooms ..	3 0	6 0	Myosotis, 12 bunches ..	2 0	3 0
Azalea, 12 sprays ..	0 0	0 0	Narciss, 12 bunches ..	0 0	0 0
Bells, 12 bunches ..	0 0	0 0	" White, English, bch.	0 0	0 0
Bouvardias, bunch ..	0 6	1 0	Pansy, 12 bunches ..	2 0	4 0
Camellias, blooms ..	0 0	0 0	Peas, Sweet, 12 bunches ..	3 0	6 0
Carnations, 12 blooms ..	1 0	2 0	Pelargoniums, 12 trusses	0 9	1 0
" 12 bunches ..	0 0	0 0	" scarlet, 12 trusses	0 4	0 6
Cornflower, 12 bunches ..	2 0	4 0	Pinks, White, 12 bunches	1 0	4 0
Daisies, 12 bunches ..	2 0	4 0	" various, 12 bunch	2 0	4 0
Day Lilies ..	5 0	7 0	Peony, 12 bunches ..	6 0	9 0
Eucharis, dozen ..	4 0	6 0	Primula, 12 blooms ..	0 0	0 0
Gardenias, 12 blooms ..	1 6	3 0	Primula (single), bunch ..	0 0	0 0
Hyacinths, Roman, 12			" (double), bunch ..	0 9	1 0
sprays ..	0 0	0 0	Polyanthus, 12 bunches ..	2 0	4 0
Iris, 12 bunches ..	2 0	9 0	Ranunculus, 12 bunches	2 0	3 0
Ixia, 12 bunches ..	2 0	4 0	Roses, 12 bunches ..	4 0	9 0
Lapageria, white, 12			" (ladoor), dozen ..	0 9	1 0
blooms ..	0 0	0 0	" Tea, dozen ..	1 6	3 0
Lilium longiflorum, 12			" red dozen ..	0 0	0 0
blooms ..	3 0	6 0	" de Moiss, 12 bunches	3 0	6 0
Lilac (white), French,			Stephanotis, 12 sprays ..	1 6	8 0
bunch ..	0 0	0 0	Tropaeolum, 12 bunches	1 0	2 0
Lily of Valley, 12 sprays	0 0	0 0	Tuberose, 12 blooms ..	0 9	1 0
" 12 bunches	0 0	0 0	Tulips, dozen blooms ..	0 0	0 0



**FORAGE CROPS.**

THAT the trials of Mr. Martin Sutton of different manures upon the permanent and temporary pastures at Dyson's Wood will be productive of good there can be no doubt. The point to which general attention will be given is the important and satisfactory fact that most of the results show a margin of profit upon expenditure of sufficient magnitude to compare favourably with that of any other kind of farm produce. So regarded, these trials assume an importance that cannot be ignored, and we have no doubt they will lead to the laying down of much corn land to permanent pasture.

In East Anglia especially the iron hand of the agricultural depression has laid hold of many a good man and true with a grip of such power that it has brought

him to poverty. Bred to corn-growing almost to the exclusion of other branches of farming, the man of ordinary ability was totally unfit to cope with difficulties arising simply from a great and apparently permanent reduction in the price of corn. Even in corn-growing his practice was but too often that which had been handed down from one generation to another. To plough, sow, and reap; a long fallow about every fourth year, followed by a dressing of farmyard manure, about summed up his routine of farming. Cause and effect, if they had attention from him, were seldom, if ever, grasped in such a manner as to lead to real improvement. In proof of the general ignorance of other branches of agriculture we may point to Mr. Sutton's experiments, for they are a tacit acknowledgment of it. If the culture of pasture, either temporary or permanent, had been understood, we may be very certain that he would not now be engaged in what are plainly termed experiments, and which, too, are so clearly intended for the general enlightenment. If further proof were required, we have it in the outspoken objections to laying down land either temporarily or permanently. Positive assertion generally springs from ignorance, and it certainly does so in this instance.

The cultivation of all forage crops is worthy of careful attention and inquiry. We must know all about the requirements of the crops we cultivate in order to obtain the greatest possible bulk per acre, and also, if necessary, be able to continue the culture of any given crop year after year upon the same field. To do this in the best way we must know all about the food required for its full growth and development, and how it obtains such food—what from the soil, what from the air. Clover-sick land arises from the simple fact of the last crop of Clover having absorbed certain manurial constituents from the soil, which must be replaced in sufficient quantity before a full crop of Clover can again be had from it. Yet what do we find many farmers doing by way of a remedy for land so exhausted? Why, they just make over the land to Nature for a time, and say they must withhold Clover from it for so many years. There is no doubt that Clover is a very exhaustive crop. Take, for example, the manurial constituents in decimals of an average crop of Clover upon an imperial acre of land, and we have of potash 73 parts, of soluble phosphate 69, and of nitrogen 140, which shows unmistakably that, though potash is undoubtedly indispensable for Clover, yet we also require heavy dressings of nitrogenous manure if we would have a full crop.

Great caution must be observed in our conclusions about the proportions of different manures to be used for pasture. The mixture we have hitherto recommended has answered so admirably upon every pasture we have tried or seen it tried upon, that it is with considerable reluctance we make any change in it. Regard must, however, be had to cost as well as efficiency, and it must be owned that nitrate of potash is very expensive, and in taking muriate of potash as a substitute we but follow the lead of Ville and other chemists. That a mixed dressing is best we proved long ago, not only as supplying all the immediate wants of the crop, but also in providing food to sustain the plant in full vigour after the first growth is removed, either as hay or by grazing. For permanent pasture formation and development we should much prefer beginning with clean, well-drained, fertile soil, sown with the best possible mixture of Grasses and Clovers, and sustained in full vigour by the timely application of manures; but old pastures may be brought into flourishing condition by judicious treatment, and we

certainly do not advise breaking them up simply because they do not contain all the best Grasses.

#### WORK ON THE HOME FARM.

Heat and drought have told upon pasture, spring corn, and root crops, especially upon light land farms. No roots, a short corn crop, bare pastures, falling prices for both lambs and sheep; these are the special troubles of light land farmers just now. There is time enough and to spare, however, for a crop of white Turnips if we do but get some rain, and so far as we have been able to ascertain early sown Mangolds are a good crop, well established in the ridges, and growing freely. The roots will probably be small, and we have in view of this had them left closer together in the rows than usual. Never was the importance of sowing early more apparent, especially among Swedes. We know some fields of Swedes now with a full plant quite as vigorous and flourishing as the best Mangold, simply because they were sown while the soil was moist and the weather showery. Often have we heard it given as a reason for the late sowing of Swedes that an early sown crop is liable to suffer from mildew. True it is that occasional patches of mildew-stricken plants may be found in a field of early Swedes, but then the greater bulk of the sound roots more than atones for such failures. The chief thing is always to be alert to seize an opportunity for getting in the seed when it has a fair chance of quick germination followed by free growth. Late sown Swedes are generally a failure this year, and silage will probably be made in larger quantities than usual, especially where Maize has been sown freely.

The nourishing properties of silage have now become clearly recognised by every unprejudiced farmer, and with the risk of failure in root crops from drought it is surely well to provide a store of forage by every known means. True it is that we are making some splendid hay and stover now, and we shall certainly do well to add to our store for next winter and spring by turning as much Maize or other herbage into silage as can be spared. No matter how it is done, whether in pits or stacks, each plan is equally good in its way. Coarse rank herbage from a bog has under pressure been converted into wholesome food as savoury and palatable as the best meadow hay. To any who question this statement, we say a visit to a well-managed stack of it must convince the most sceptical of its truth.

#### PERMANENT OR TEMPORARY PASTURES.

In a letter advocating the laying down of temporary pastures, Mr. J. H. Millard adduces the following testimony of Monsieur H. Joulie, and read before the Société des Agriculteurs de France:—

"Of all the various methods for producing hay, the best, without doubt, is that of temporary lays, composed either of Graminaceæ alone, or of a mixture of Graminaceæ and Leguminosæ, according to the nature of the soil. Are not fields of Leguminosæ, such as Clovers, Sainfoin, Lucerne, which are of such service in well directed farming, simply temporary grass lands? The merits which have so long been recognised in them belong equally to temporary occupation by Graminaceæ, and these have, moreover, the advantage of being serviceable as pastures, which is only seldom the case with fields of artificial leguminous Grasses.

"The practical application of this principle is, that the temporary occupation of the land by a grass ley for two or three years, which takes its turn in the rotation of crops, should be preferred to temporary occupation by grass. We thus secure the improvement of the soil obtainable from the cultivation of Clover, Lucerne, Vetches, &c. But as this class of plant will not succeed on every soil, temporary leys with graminaceous herbage ought to give, where leguminous plants do not succeed, analogous if not equally good results, and so assist us materially in solving the problem of producing cereal, root, and other crops with increasing economy."

#### METEOROLOGICAL OBSERVATIONS.

CAMDEN SQUARE, LONDON.

Lat. 51° 33' 40" N.; Long. 0° 8' 0" W.; Altitude, 111 feet.

DATE.	9 A.M.					IN THE DAY.				Rain
	Baromet. ter at 32° and Sea Level.	Hygromet- er.		Direction of Wind.	Temp. of soil at 1 foot.	Shade Tem- perature.		Radiation Temperature.		
		Dry.	Wet.			Max.	Min.	In sun.	On grass.	
1887.										
June and July.										
Sunday .....	30.272	55.4	52.8	N.E.	62.0	62.6	48.2	76.5	47.4	—
Monday .....	30.227	59.3	54.4	E.	60.8	64.2	43.0	121.5	38.2	—
Tuesday .....	30.240	64.3	58.9	E.	62.2	75.3	53.9	118.6	50.1	—
Wednesday .....	30.425	66.2	59.6	N.E.	62.6	78.2	58.2	125.5	58.2	—
Thursday .....	30.451	61.7	57.0	N.E.	62.3	71.1	53.3	108.8	48.7	—
Friday .....	30.371	64.7	58.6	N.E.	62.2	82.3	49.1	130.8	44.8	—
Saturday .....	30.263	74.1	63.8	N.W.	61.8	81.9	54.8	116.8	50.2	—
	30.323	61.2	57.9		61.2	76.5	51.5	114.1	48.2	—

#### REMARKS.

26th.—Dull and cold, but close all day.  
27th.—Close hazy morning; bright hot afternoon.  
28th.—Cloudy and cooler in the morning; warm, with a good deal of sun in afternoon.  
29th.—Fine but close.  
30th.—Cloudy morning, afternoon fine, and generally bright.  
1st.—Warm and fine, but at times cloudy.  
2nd.—Fine and warm.  
The third consecutive rainless week and a hot one, the fourth considerably above the average.—G. J. SIMONS.





## COMING EVENTS

14	TH	Alexandra Palace Rose Show (three days).	Birmingham, Harleston,
15	F	Helenburgh and Hereford Shows.	[and Chiswick Shows.]
16	S	New Brighton Show.	
17	SUN	6TH SUNDAY AFTER TRINITY.	
18	M	Christleton Show.	
19	Tu	Leek Show.	
20	W	Birkenhead Show.	

## PACKING FRUIT.

**P**ERHAPS of all indoor and outdoor fruits Grapes are the most difficult to pack for a long railway journey without injury. Those who grow for home consumption only, and can dish up their fruit directly it is cut from the Vines, may consider themselves fortunate in comparison with those who have to pack the bulk of the produce they grow. Full credit is not always accorded to the latter cultivators. Not long ago I heard the remark, "What an excellent bloom there is on your Grapes! Ours are not so tempting, for they are often very badly rubbed." No allowance being made in the case of the one who had to pack his fruit for a journey of nearly 300 miles, to be then unpacked by persons who would not handle the fruit with the same care as the producer. The Grapes with the fine bloom had only to travel from the vinery to the house.

It may be contended that Grapes can be packed to travel any distance without injury to the bloom, and this I admit, for hundreds of examples can be seen at our great fruit shows from all parts of the kingdom without the slightest blemish. If gardeners could follow the same plan for the conveyance of fruit from the vinery to the table as is the case when staged in the exhibition tent, then all fear of the appearance being injured would be removed. This system would not be tolerated except on special occasions, for the cost in conveyance would amount to more than the fruit was worth. Economy has to be too closely considered in the management of gardens at the present day to think of attempting any such practice. I think that it is almost impossible to pack Grapes in an ordinary way without the bloom being damaged. I have examined hundreds of examples that have been packed both for the market and private use, and have always observed that those that had been well packed were slightly rubbed. Grapes can, however, be packed in various ways to arrive in good condition without their appearance being injured to any serious extent.

Whether Grapes arrive in good condition or the reverse depends almost entirely upon whether the fruit is overripe, the bunches firm and compact, or the reverse. Those that are overripe—take Black Hamburgs for instance—are very difficult to pack to insure their giving satisfaction when they reach their journey's end. With the least pressure or knocking about the berries fall from the footstalks. Grapes in this condition are seldom packed for the market; most varieties, even if kept for months after they are ripe, adhere to the footstalks much more firmly than is the case with the variety named, and the berries are far less liable to burst. When the fruit is in this condition large quantities must never be packed

in the same box or basket for fear of the whole being spoiled. Pack each bunch separately, so that the risk of destruction can be limited. Large bunches are as bad to pack satisfactorily as Grapes that are overripe; they are certain to be rubbed to a much greater extent than those of moderate size, which are the best for travelling. Varieties that have long tapering bunches and are moderately wide across the top are perhaps the most difficult of all to pack well. Loose bunches are much more liable to rub one another when packed together in quantity than those that are firm and compact.

Packing Grapes for the market and for private use are two totally different matters. For the former they are generally packed in larger quantities than are needed by private establishments. For instance, a basket or box, or a number of each, is sent away at one time according to circumstances, while on the other hand a regular supply has to be maintained in most cases, and two, four, six, or more bunches may have to be packed at intervals of a few days along with other fruits and garden produce. In cases of this description the quantity to be sent is insufficient to fill a box or basket unless very small, and if these were provided they would invariably upset other arrangements where boxes, trays, or tins are so arranged to fit in one large box or hamper.

For some years we have been in the habit of sending small quantities of Grapes a long distance during the greater portion of the year two or three times a week, and found the best method of packing was to place each bunch separately. The paper used was moderately stiff and highly glazed on one side. These were prepared as if for sugar, and tapered from the top to the point according to the size and width of the bunch, the point being doubled up before inserting the bunch, and the top carefully folded over the stalk. These were then packed in tins upright, or laid on their side, whichever way they would fit best, a little cotton wool being placed between them, and to fill the tin, so that they could not shake about. The paper used must be sufficiently stiff to remain straight and as smooth as possible inside, then few berries will be rubbed. Some years ago to test this principle I had two bunches sent a long distance, then returned, with scarcely any perceptible damage to the bloom. I may say, if the paper is not highly glazed the whole of the bloom will be removed from the berries that touch it. Care is necessary in placing the bunches into these papers and in folding them and taking them out again. The papers are easily pressed straight, and can be used several times.

When numbers of bunches are required to be packed these may be placed closely together in baskets or boxes with but little material. The basket or box used must be full, then but little rubbing will take place. If baskets are used they can either be square, oblong, round, or oval. If of the latter two they are all the better if they taper gradually from the base upwards, then the bottom portion of the basket is certain to be filled. If we had large quantities to pack at one time for market oval baskets with a handle across them, tapering as described, would be preferred. In square baskets the difficulty is to fill the bottom where the bunches taper as well as the top. With a little care this can be done. For instance, a layer of moss, cotton wool, or paper shavings should be spread over the bottom, then a layer of tissue paper, and the same up the sides of the basket. At the end where it is intended to commence placing the bunches the same material as used for the base may be sloped gradually

from the base to the top, so that the first bunches practically lie in a sloping direction instead of being upright. The bunches may afterwards be placed close together, and when there is room only for the last row of bunches the basket may have a sharp tap on the end where the first bunches were laid. It can now be ascertained what vacant space will be left at the bottom after the last row of bunches is placed in, and this should be filled behind the paper with packing material, so that the point of the bunches will fit tightly. Any corner or vacant space in the basket where the Grapes do not fill it exactly should be made good with packing material, so that no movement can take place when the lid is closed. A sheet of paper over the top will be all that is needed, provided the basket is full; if not, over the paper place cotton wool or any other material at hand. If the baskets have only to be conveyed a short distance all this care is not needed, but for a long journey too much attention cannot be paid to filling the basket, so that no movement of the fruit can take place.

Peaches are more easily packed than Grapes. For market purposes they should be gathered just before they are ripe. For private use they have to be gathered in most cases when fit to be placed on the table, and under these circumstances packing has to be done even more carefully. Perhaps the worst Peach of all to pack is *Noblesse*. If gathered before it is ripe for the market it never possesses that beautiful golden colour that it attains if left on the tree until it is ripe. When ripe it is almost impossible to pack the fruits without their being damaged; in fact, it is a difficult matter to gather them from the tree without bruising them. It is one of the most delicious Peaches that can be grown for home consumption if gathered from the tree and placed on the table at once, but for packing purposes it is unsuitable. Amongst Nectarines *Lord Napier* is difficult to remove from the tree if allowed to remain until it is ripe. It clings even when thoroughly ripe closer than any Peach or Nectarine known to me. When needed for packing it should be gathered before it is ripe, and placed in the full sun for a few hours before removal to the fruit room. It can then be packed without injury, but the great difficulty is to remove them from the tree. For these fruits boxes or tins should be provided 3 to 4 inches deep—boxes of both depths are advisable. A layer of cotton wool should be placed at the base, then a sheet of tissue paper for the fruit to rest upon. In the case of Peaches we take a strip of cotton wool and place it in tissue paper, and bind it once round each fruit and place them closely together. The tissue paper is not needed in the case of Nectarines, for the wool will not give trouble by sticking to them as is the case with the rough skin of the Peach. The small corners between the fruit can be filled with cotton wool, but this is not needed if the fruit is packed closely together. Over the fruit place a sheet of tissue paper, and then one of cotton wool, to ensure the box being full when the lid is placed on. If this is attended to the fruits will never move, and will be found in as good condition when removed as when they were placed in the box.

Figs are rather bad to pack, especially if they are allowed to hang until they are thoroughly ripe. These should be placed in shallow boxes 2 or 3 inches deep, according to the size of the fruit. A layer of wool should be placed at the base, then tissue paper, and each fruit in a soft Vine leaf with the stalk of the leaf uppermost. If placed firmly together, a few Vine leaves over the top to fill the box will ensure their travelling safely.

Melons are amongst the easiest of fruits to pack, and may be placed in baskets or boxes. Each of the fruits should be rolled singly in cotton wool and then placed closely together amongst paper shavings, nothing is better. Dry moss or even hay can be used and will answer the same purpose. The only caution needed is to preserve the stalk and fill the box or basket containing them so that they cannot move.

Plums and Cherries are not difficult to pack to ensure their travelling well and arriving in good condition. For dessert purposes they can be laid closely together with a thin layer of cotton wool at the base, covered with a few soft Vine leaves. The stacks of the latter may be left about 1 inch long and the box made full the same as advised for other fruits. Two layers of these fruits may with safety be packed in the same box by placing between the layers a few soft leaves. For cooking or market purposes small hampers can be packed full without any injury, provided the fruit has not been allowed to become too ripe.

To ensure Strawberries arriving in a fresh condition, as if only just removed from the plants, requires considerable care. The flesh is soft and easily bruised, although some travel much better than others. No fruit arrives in the market in a worse condition than these. I allude especially to those gathered out of doors. Hundreds of tons find their way into the market with anything but an inviting appearance. It may not pay to spend more time and care in packing the fruit, but I cannot help thinking that a better price could be obtained for perfectly fresh unbruised fruits than for that which has the appearance of having been partially made into jam. To insure good travelling varieties, such as *Sir Joseph Paxton*, arriving in good condition not more than two or three layers at the most should be packed in each box with leaves between the layers. We have recently been packing on this principle, and were informed that the fruit came out in excellent condition. With forced fruits greater care certainly is taken, not only for private use, but with those sent to the market. Our plan for years has been to place one layer in shallow trays or boxes with cotton wool at the base, then a layer of leaves, each fruit being placed in a soft Strawberry or Lime leaf, the latter we prefer when they can be had; the box is then filled in the same way. We have packed them with the stalks down and with them up, and although the fruits travel equally well either way, we are inclined to prefer the latter, for the fruit is more readily removed when wanted. For years we packed in shallow tins that held several pounds of fruit, but prefer small narrow boxes that will hold from 1 or 2 lbs. Boxes that hold about 1 lb. are much preferred early in the season when the fruit is sent to the market. This season we have packed a quantity of fruit in small shallow boxes without placing each one in a single leaf for travelling any distance; this method is not advisable, but for short distances they can be packed much more quickly—which is a consideration when growing for market—and without injury to the fruit, especially all those varieties that have moderately firm flesh.—WM. BARDNEY.

## THE GARDENERS' ORPHAN FUND.

### GENERAL MEETING.

THIS Fund is now established, the rules, subject to a few small alterations, having been adopted, and the various officers elected at the first general meeting held at South Kensington on Tuesday last. It was in every way a most successful meeting, and it was the unanimous opinion of those present that in *Sir Julian Goldsmid, Bart., M.P.*, the Orphan Fund has secured a President of marked ability, great business aptitude, and in strong sympathy with the object of its promoters. Amongst the supporters pre-

sent at the meeting were:—Sir Julian Goldsmid, M.P., who presided; Dr. Hogg (representing the Council of the Royal Horticultural Society); Dr. Masters; Messrs. G. Deal, H. J. Veitch, Penny, Wynne, R. Dean, Shirley Hibberd, Noble, Fraser, Laing, J. Fromow, D. T. Fish, W. Richards, Herbert, Roberts, Wright, Udale, A. F. Barron, &c.

Mr. DEAL read the report of the Provisional Committee:—

[TO THE DONORS AND SUBSCRIBERS TO THE GARDENERS' ORPHAN FUND.

LADIES AND GENTLEMEN,—

We, the members of the Provisional Committee, nominated to conduct the initiatory proceedings in connection with this Fund, have now the pleasure to present our report, which is, in fact, an epitomised statement of our labours, and will show how the idea of the "Gardeners' Orphan Fund" originated, developed, and step by step reached its present proportions.

Early in March last Mr. Penny, gardener to His Royal Highness the Prince of Wales, Sandringham; Mr. Clayton of Grimston Hall, Tadcaster; and Mr. Udale, Elford Hall, Tamworth, suggested in the horticultural papers that the most fitting way for the gardening community to commemorate Her Majesty's Jubilee would be to establish a Gardeners' Orphanage or Fund for the benefit of orphan children of gardeners. The idea met with approval, and a meeting was held March 24th in the Conservatory of the Royal Horticultural Society, South Kensington, to take into consideration the suggestion and the best means of furthering it. The subject having been fully discussed, a resolution was passed to the effect that it was desirable to establish such a Fund, but that it was not desirable to purchase or erect any building as an Orphanage. It was further resolved to appoint a Provisional Committee to prepare a scheme for carrying out the objects of the meeting, and the following gentlemen were nominated:—Dr. Masters (*Gardeners' Chronicle*), Mr. Shirley Hibberd (*Gardeners' Magazine*), Mr. Deal (Weeks & Co, Chelsea), Mr. James Douglas, Great Geables, Ilford, Mr. C. Penny, Sandringham, Mr. C. H. Sharma (James Carter & Co., Holborn), Mr. J. H. Veitch, Chelsea; Mr. J. Roberts, Gunnersbury Park; Mr. J. Woodbridge, Syon House; Mr. A. F. Barron, Chiswick; Mr. R. Dean, Ealing; Mr. J. Matthews, Weston-super-Mare; Mr. J. Wright (*Journal of Horticulture*); Mr. B. S. Williams, Holloway; Mr. W. Richards (*Gardeners' Chronicle*), and Mr. B. Wynne (*Gardening World*).

This Committee held its first meeting on March 25th, and again met on April 12th, when the members present (after first agreeing to defray preliminary expenses should the scheme fail to mature), discussed the lines upon which the Fund should be organised and conducted. A circular letter was drawn up and widely circulated, with a view of testing the feeling of gardeners respecting the proposals. The result was highly gratifying, inasmuch as in a short time promises of support were received in the form of donations and subscriptions to the amount of £400. By May 21st the amount had reached nearly £600, and now exceeded £930.

At a meeting of the Committee held on the last mentioned date, the progress made was considered sufficiently satisfactory to warrant the calling of a public meeting to establish the Fund. It was therefore resolved to convene such a meeting for July 12th, and a sub-committee was appointed to make the necessary arrangements, also to draw up rules and regulations for the general management of the Fund.

This sub-committee, consisting of Messrs. Barron, Deal, Dean, Roupell, Woodbridge, Wright, and Wynne, at once proceeded to consider and revise the draft rules submitted by the Chairman, which, after much anxious consideration, were agreed to, and are now recommended to the subscribers for adoption.

The Committee have been much encouraged in their labours by the fact that so distinguished a friend to horticulture as Sir Julian Goldsmid, Bart., M.P., &c., has kindly consented to accept the office of President, and trust that the donors and subscribers will cordially endorse this selection, and approve the initiatory proceedings in general.

In conclusion, the Committee beg to offer their best thanks to the subscribers and all who have so kindly given them their assistance and support.

The CHAIRMAN: It becomes my duty as Chairman of the meeting to-day to move the adoption of the report and of the rules which are recommended to you by the Provisional Committee. I have just looked at their minute book, and I see that they have held nine meetings, and consequently it is obvious that they have carefully considered the various questions which they have had to deal with, because, as they are all business men, and know the value of time, I am sure they would have been unwilling to spend time over nine meetings unless it had been necessary to mature the proposal they put before you. The proposal is one which recommends itself to everyone who has an eye to nature. I think that we shall all agree that the gardeners of to-day offer us beautiful objects to look at, which in former days were almost unknown. I was looking, for instance, just now at that wonderful collection of Begonias downstairs. When I was a boy I think many of these were not known at all, and consequently our forefathers lost the advantage and beauty of those splendid objects. So, in the same way, all through the different classes of plants you will find that wonderful improvements have been made by the able gardeners of to-day. I am quite sure that the gardeners who look after these things which are so beautiful, ought also to look after themselves and their families. (Hear, hear.) Now, every one of us is liable to sickness, and of course now and then the head of the family is removed, and his children are left to battle with an eager and a greedy world. Just as it is the duty of those in other trades and occupations of life to endeavour to provide for their poorer neighbours and for the orphans of those removed from them in an untimely manner, so I believe those who originated this idea were right in saying that it is in the same way the duty of gardeners to provide for those connected with them who are placed in similar unhappy circumstances. We all know that there is an excellent Society called the Gardeners' Benevolent Society, which looks after gardeners when they are broken down and cease to be able to take their share in their work; but there has hitherto been no organisation to provide for the children of those who were suddenly removed by death; and it is to fill up this gap, to avoid in future the risks and the difficulties that the children of gardeners who die are naturally exposed to, that it has been decided to establish the Gardeners' Orphan Fund. It is in promotion of this organisation that the Provisional Committee have called you here to-day. I have much pleasure in presiding at this meeting, and am glad to be able to ask you to adopt this report and to accept the rules which are recommended to you. Of course, I do not say that the rules now proposed to you are the most ideally perfect that can be prepared, but I do say that in every institution it is desirable to have rules. These have been carefully considered. If in the course of a few years' experience it is found by the Committee which manages this Institution that any modification is desirable, I am sure they will be prepared to recommend them to the subscribers. At the same time, I think we cannot do better than adopt the rules which they recommend to us, for they have very carefully prepared them, after having considered the various points brought before them by their Chairman and others. Consequently I have much pleasure in moving the adoption of the report and the rules. (Cheers.)

Mr. PENNY seconded the motion, and said he thought that they would all feel that they were now placed in a much different position to what they were on the 25th March, when they met in the conservatory, without any rules and without any money. Since then the object for which they met had, to a great extent, been achieved, and he expressed the hope that the Institution would go on and prosper, and make as much progress in the future as it was already making. In endeavouring to further the interests of the Institution he had met with a wonderful amount of kindness. With reference to the rules, the Committee had worked very hard in order to make them what they were. He wished, however, to state that if anyone who heard him or might read what he said, had any suggestion to make, if he would write to the Secretary those suggestions would receive proper consideration. He hoped those who did not join the Society would not find fault with them, but if anyone had a suggestion to make for the improvement of the organisation, he had no doubt that those suggestions would be well considered. (Cheers.)

Mr. SHIRLEY HIBBERD said he wished to make an observation in reference to rules 9 and 10, and what he had to say would not be likely to divide the meeting. The smallest thing was of importance in an affair of this sort. In rule 9 it was provided that a charge of one shilling should be charged for a copy of the annual report, balance sheet, and list of subscribers. It had occurred to him that a penny would be a more reasonable charge. That was a small matter, but the next thing was from his point of view of considerable importance. It was provided that the annual meeting was to be held in February. That seemed to him to be fatal to its success. Meetings in February in London did not succeed as one could wish. Men of years did not attend them wherever they might live. Men who lived in the country would not attend them, for it was not a time for travelling. He therefore suggested that they should fix the price of reports at a penny, and that the annual meeting should be held in May instead of February.

Mr. ROPELL was very sorry to have to disagree with Mr. Hibberd. He had found in practice that no objection was made to paying for the report and list of subscribers. Anyone who applied for a copy with some business-like object would not object to pay a shilling for it; and he had never found any complaints made on the part of such applicants because they had to pay for the report. As to the time of meeting, that of course was a subject for consideration. Many of the charities held meetings in the beginning of the year, and generally they got a good attendance. He did not know any better place to meet in than London, in the month of February.

Mr. D. T. FISH objected to the mode of election provided by rule 12 in the case of candidates for the benefit of the Institution. The system, he knew prevailed in other similar institutions, including the Gardeners' Benevolent Institution, and he had had some experience of this mode of election by the votes of subscribers. He thought that the system led to a great deal of abuse in the administration of such charities. He saw a statement made the other day by a society that was trying to abolish this mode of election, that at least one-third of the benefits were paid in postage and canvassing. He thought that in establishing this new Institution, the promotion of which reflected great credit upon those who initiated it, they should consider whether it was not practicable to abolish this mode of election and allow the Committee to elect the candidates. According to the rule the Committee were to select a list of candidates, and he thought the selection by the Committee would be the same as if they had actually elected the candidates. (No, no.) As they had gone so far in giving the Committee that power, he did not see that they should not go a step further, because he had no doubt that the Committee who would administer the fund would be highly influential and thoroughly representative. His experience in three institutions with which he was connected was that the result of canvassing and bartering and higgling about the votes was that the most deserving candidates were not elected. He would far rather trust to such a body as he knew would be elected by this Institution than to the votes of subscribers. He had heard it said that a good many subscribers would not subscribe if they had not the power of voting. All he could say was that it would be a great relief to him if he were not pestered with applications in reference to his votes.

Mr. DEAL said perhaps as Chairman of the Provisional Committee he might be expected to say a word or two upon the rules. He would take Mr. Shirley Hibberd's objection first, with reference to paying one shilling for the report and list of subscribers. He thought it was very well known that whenever an application was made for the rules and list of subscribers of any institution it was generally for the purpose of getting the list of subscribers and not so much for the rules. The Committee had wished as far as possible to check any undue expense which might be thrown upon the fund in printing these rules. They must bear in mind that even the first issue would be at a considerable cost. They had 700 names to put into the book; they had the report, the list of officers, and the report of the meeting, and to issue all that for the nominal sum of a penny would be throwing a considerable cost upon the Fund. He was quite prepared, if it were thought advisable, to agree to presenting reports to a certain number of the leading subscribers, but he assured them that they would be considerable losers by the transaction if they charged only a penny for a copy. The matter had been thoroughly threshed out by the Committee, and he hoped the meeting would adhere to the one shilling. With regard to holding the annual meeting in February, he was willing to agree to the alteration suggested by Mr. Hibberd, and to hold the meeting in May. With regard to the mode of election, that had received the serious consideration of the Committee. It had been thoroughly discussed, and arguments had been advanced *pro* and *con*. Other charities had been consulted on the matter, and he might now say in the briefest manner that, without exception, every person who had had practical experience in promoting the welfare of such institutions, had one and all told him—and he thought he had the support of the Committee in what he was saying—that, if they took away the voting from subscribers, they would take away the interest, and if they took away the interest they would get no money. He was afraid that if they abolished the rule it might give rise to the impression that the whole Institution was the property of the Committee, and that subscribers who lived at Carlisle or Newcastle would have very little to say in the matter. He was for spreading the power of voting throughout the length and breadth of the land. He was therefore against abolishing the rule, and was decidedly in its favour.



The CHAIRMAN: I should just like to say a word or two upon the matters mentioned. The point with regard to the charge for the annual report, balance sheet, and list of subscribers is, I think, an important one in this sense, that if you do not make some charge you may have to print a very large number, and as it is hoped that all the gardeners of England will ultimately belong to this Society, you will find that to get up a book of subscribers will be a very expensive affair. Consequently you will diminish the fund which you are establishing for the benefit of the orphans. I therefore think it would be better to charge one shilling, or some sum which will amply cover the cost of the book. With regard to the second proposal, on the whole I agree with the gentleman who said that February is not a good month, as some later month for an annual meeting. There is this to be remembered, that the Committee hope gardeners will come from all parts of England to attend this meeting. As you know the month of February this year was very disagreeable, and the weather was very bad, and many people would hesitate before they took the journey up to London. Gentlemen who live in the country would not be very anxious to come here even to attend the annual meeting of such a useful institution as this. What I suggest to the Committee is, that they might put in the word "Spring," which will leave a little margin to the Committee to fix the exact rate of the meeting. It does not signify very much whether it is held in April or May. (Hear, hear.) With regard to the mode of election, I very much sympathise with what Mr. Fish has said. Belonging, I think, to about forty institutions. I get applications without number to vote for various candidates, and if I had not a very excellent Secretary, who is good enough to keep lists of all these institutions, and the persons to whom I have promised my votes, I should be in very great difficulty. At the same time we must look at the practical side of the question. Theoretically it would be a good thing if the Committee could select the most deserving candidates, but you must remember that everybody is not so high-minded and generous as Mr. Fish; and consequently some people like to have what they call full value for their money, and to many people full value for their money even when given in the form of a subscription is the vote. I have tried over and over again in other institutions to persuade the subscribers that they would relieve themselves of great trouble by dispensing with their voting power, and they have replied, "It is not trouble, but a pleasure." Therefore, what are you to do? On the whole, I think the Provisional Committee have struck a very capital road between these two opposing powers. If you look at the latter part of the clause, they say that "before the annual general meeting, the Executive Committee shall examine the claims and qualifications of candidates, and prepare and approve a list of those eligible, and from this list the election shall be made." That indicates that the Committee will strike out any candidates whom they do not consider to be deserving candidates. In that respect they exercise a certain amount of selection. Having chosen the eligible and deserving candidates, they say to those who subscribe, "Out of those you choose whom you like." I think, therefore, it is a good middle road between the two opposing powers, and on the whole, though sympathising very much in what Mr. Fish has said, I should advise the meeting to adopt the plan suggested in the proposed rules.

Mr. GREEN said that the month of May was a busy time with gardeners, and would be an inconvenient time for the annual meeting. He suggested that it should be held in August or September—(No, no)—or, at all events, at a less busy time of the year. He would also suggest that at the same time there should be some other attractions for gardeners, such, for instance, as the show like that which was being held. (Hear, hear.)

Mr. VEITCH proposed that the annual meeting should be held in July. This was agreed to.

The motion for the adoption of the report was then carried.

Mr. VEITCH proposed that Sir Julian Goldsmid be elected President of the Gardeners' Orphan Fund. He felt that in selecting him they would have the right gentleman in the right place. Sir Julian had already told them that he was connected with forty institutions. He (the speaker) was thankful to say that theirs was the forty-first with which he had associated himself. He was quite sure that the experience which Sir Julian Goldsmid had gained in connection with other institutions would be for the advantage of the Gardeners' Orphan Fund. Sir Julian was in great sympathy with the gardeners of England, and the interest which he took in their occupation was shown by the beautiful place which he had at Tunbridge Wells, and the beautiful gardening which he carried out, by means of an English gardener, in the south of France. He might mention, as another evidence of the interest which the Chairman took in this movement, the fact that he had given £100 towards the Fund. He thought they would agree with him that they could have no more excellent President than Sir Julian Goldsmid. (Cheers.)

Dr. MASTERS seconded the motion, which was unanimously adopted.

The CHAIRMAN in acknowledging his appointment said: I am very much obliged for the kind observations which my friend, Mr. Veitch, has made. Of course we all know that he stands at the head of that enterprising profession to which he does so much honour. I am quite sure that in the interest that can be taken in the progress of gardening I can equal anyone, because I know that more is to be gained by the observation of the beauties of Nature than almost any other kind of intellectual work, and I am satisfied that you who spend your lives in producing beautiful things are devoted to a profession that does you great honour. I have to thank you for the honour you have done me, and I have great pleasure in accepting the post of President.

Mr. DEAL proposed that Messrs. H. J. Adams, E. J. Beale, W. Bull, Shirley Hibberd, Dr. Hogg, Dr. Masters, J. McIntosh, H. M. Pollett, Baron Schroder, Messrs. A. W. Sutton, H. J. Veitch, and F. G. Tautz be elected Vice-Presidents of the Gardeners' Orphan Fund. He explained that this was only the list made up to the present time, and that under the rules the Committee would have power to add to their number.

Mr. WYNNE seconded the motion, which was carried.

On the motion of Mr. FRASER, seconded by Mr. NOBLE, Messrs. S. Courtauld, J. T. D. Llewelyn, and A. H. Smee were appointed Trustees of the Fund.

Mr. SHIRLEY HIBBERD moved the election of Mr. T. B. Haywood as Treasurer, and said many of them knew Mr. Haywood was Treasurer of the National Rose Society, and in various ways was interested in horticulture.

The important point was as to the custody of their money. The opinion appeared to be that it would be perfectly safe in Mr. Haywood's hands. (Laughter and hear, hear). He would take this opportunity of saying in reference to the suggestion which had been made, that holding the annual meeting in July would afford them an admirable opportunity of increasing the burdens on the Treasurer's shoulders. (Laughter.) A gentleman had suggested that on the occasion of the annual meeting, or in connection with it, they should have some kind of floral jollification. (Laughter.) If that could be carried out in a large way there was no doubt whatever that it would conduce to the prosperity of the Institution. They might have some outdoor festival in which gardeners and horticulturists generally might take an interest. He would mildly suggest a comfortable meeting, in which the ladies might be associated with them, and where something to eat and drink be provided; or they might have a Strawberry feast or what they liked. An outdoor festival for the benefit of the orphans would have a certain domestic character, and he was sure would be calculated to enlarge the labours of their worthy Treasurer. (Laughter and cheers.)

Mr. LAING seconded the motion, and it was carried.

Mr. DEAN proposed the election of Mr. A. F. Barron as Secretary of the Fund. He said that in asking Mr. Barron to accept the post they were selecting a gentleman who was known to all of them. There were three reasons why they should appoint Mr. Barron to the secretaryship. The first was that he was the best known man in the horticultural community. (Hear, hear.) In the second place he was greatly esteemed for his high personal character and business capacity. In the third place, from the very inception of the Fund, Mr. Barron had taken an important part in bringing the scheme up to its present point of success. (Cheers.)

Mr. ROBERTS seconded the motion, and it was unanimously adopted.

Mr. WRIGHT moved the appointment of Messrs. J. Fraser and W. Sharp as auditors, remarking that both those gentlemen were well and widely known—the former as a horticulturist, the latter as being specially identified with work of the nature indicated—and he did not think that two more suitable for the position could be chosen.

The motion was seconded by Mr. Richards and carried.

On the proposition of Mr. Fish, seconded by Mr. Udale, the following gentlemen were appointed an executive, with power to add to their number:—Messrs. P. Barr, W. Bates, H. Canneil, R. Dean, G. Deal, J. Douglas, W. Goldring, W. Head, H. Herbst, W. Holmes, W. Ingram, J. Laing, G. Nicholson, C. Penny, W. Richards, J. Roberts, W. Roupell, C. H. Suarman, J. Smith, H. Turner, H. Williams, J. Woodbridge, J. Wright, B. Wynne.

Mr. DEAL, in reference to a wish expressed that country members should be represented on the Committee, explained that the rules provided that the Secretaries of Local Committees were to be ex-officio members of the Committee, and as it was the intention of the Committee to establish a large number of Local Secretaries, the country would be largely represented.

On the motion of Mr. Wright, seconded by Mr. Deal, a cordial vote of thanks was accorded to the Royal Horticultural Society for the use of their room for this meeting.

On the proposition of Dr. Masters, seconded by Dr. Hogg, the Chairman was cordially thanked for his kindness in taking the chair, and Sir Julian Goldsmid briefly acknowledged the compliment.

Mr. BULL proposed, and Mr. Herbst seconded, a vote of thanks, which was passed, to the Horticultural Press for their interest and assistance in reference to the Institution.

The compliment was acknowledged by Mr. Wynne.

The proceedings then terminated.

## FLORAL DECORATIONS.

THE Royal Botanic Society's Evening Fête, in their beautiful gardens at Regent's Park, is one of the events of the season which is always looked forward to with considerable pleasure, and it invariably attracts a large number of distinguished visitors. The Fête and show of the floral decorations on Thursday last would compare favourably in all respects with any of the productions of preceding years; the gathering was also favoured by exceptionally fine weather, which assisted greatly in rendering it highly successful. The Society, with their Secretary, Mr. William Sowerby, and Curator, Mr. Coomber, have every reason to be satisfied with all their exhibitions of the present year, which well maintained the fame the Regent's Park shows have so long enjoyed.

The spacious marquee, together with the approaches and corridor appropriated to the two summer shows, was as usual devoted to the floral decorations, for which prizes were offered by the Society, and in several cases the competition was extremely keen. As is customary at shows of this character, much diversity of taste was displayed in the arrangements submitted to the Judges, and in some instances the latter functionaries bestowed their commendation upon efforts that, in the opinion of many experienced and disinterested decorators, rather merited condemnation. Differences of opinion always exist respecting matters of taste, but there are limits within which we may expect such divergences to be confined, though some seem to endeavour to indicate the independence of their judgment by defying all rules. These remarks do not apply to the winning exhibits in the majority of the classes, which were carefully selected, and to which exception could only be taken in two or three instances, but to the additional recognition accorded to some of the unsuccessful competitors. Twelve classes were provided, but we can only refer to a few of the leading features, and the floral decorations for a dinner table, 10 feet by 5 feet, were the most largely represented, some sixteen competitors entering. Messrs. G. & J. Lane, St. Mary's Cray, won first honours for an extremely light, graceful, and bright arrangement, with a single central trunk stand, the base filled with white Water Lilies, double scarlet Tuberosus Begonias, Grasses, Ferns, and Asparagus plumosus, the top containing Grasses, Asparagus, single and double Begonias, and a few leaves of Caladium

argyrites. Small corner and other glasses each contained a few bright effective flowers and a little elegant foliage. Mrs. Chard, Brunswick Nursery, Stoke Newington, was a capital second with a charming arrangement, simple in design, but effective and tasteful. In the two central stands white and pink Rhodanthes, with Aquilegia chrysantha and Brizas, furnished the upper part, the base containing Cattleya Mossiæ flowers, Liliun longiflorum, and Gladiolus Colvilli albus, with sprays of Lygodium scandens round the stems. The side stands were filled with Roses and yellow Carnations, the ten small glasses containing a single flower each of a pink Rose. Mr. W. Gardiner, 127, Queen's Road, Bayswater, was third with a very elaborate arrangement of white Water Lilies, mauve English Irises, and yellow Sweet Sultans, with Grasses and Typhas, on a large central mirror, but it had too heavy an appearance to please many persons. A certificate of merit was awarded to Miss Paget, 34, High Street, Clapham, for a peculiar contribution, consisting of two huge cushions 2 feet in diameter and 1 foot high, composed of white Pinks, with three dark crimson Roses at the top, and a central crown also of white Pinks, Miss Jolliffe Carnations, dark crimson Roses, and Myosotis. This exhibitor evidently possesses considerable floral taste as displayed in another class, but much time was wasted in the production of the exhibit in question, and we consider, in common with many others who saw it, that the Judges passed several far more meritorious exhibits in according this an official recognition. The table decorated with seaweed by Mrs. Smout of Hastings was exquisitely delicate. Mr. Arthur Parmley, 19, Park Side, Albert Gate, had an effective and simple design, consisting of wreaths of La France Roses with foliage, the only fault in which was that rather too much material was employed, an evil which could have been easily rectified. Mr. J. E. Anderson, Belsize and Eton Road, Hampstead, had some graceful baskets of double pink Pelargoniums with Ferns and Japanese Maples, the centre of Liliun speciosum rubrum, and several others could be named both original and pretty.

In Class 2 the prizes were offered for table decorations under the same conditions as the other, but dressed ready for use. There were eight exhibitors, Messrs. Hooper & Co., Pineapple Nursery, Maida Vale, winning the chief honours for a handsome and novel arrangement. In the centre of the table was a large cut-glass bowl supported on a gilt stand, filled with Cattleya Mossiæ, Odontoglossum crispum, and Ferns, ten other glasses of various sizes much smaller than the central one being filled with Brizas, Agrostis, and other graceful Grasses, and a few Miss Jolliffe Carnations. Messrs. Cullum & Sharpus, 13, Piccadilly, were second with a varied and tasteful display in central trumpet stands and side dishes, the third prize being awarded to Dick Radclyffe & Co., High Holborn, for an arrangement in green and variegated foliage, which had a rather heavy, dull appearance at night. A certificate of merit was awarded to Miss Paget, this time amply deserved, for a graceful combination of flowers and foliage.

Class 3 was for three groups of floral decorations for a dinner table, only one kind of flower to be used in each group, a condition with which several of the exhibitors failed to comply. Messrs. G. & J. Lane were first, their central stand comprising white Water Lilies, Carex, Purple Beech, and Ferns, the side stands containing crimson and yellow Roses, with arches of Asparagus. Mr. A. F. Youens, Leigham Court, Streatham, was adjudged the second prize for a neat central basket of crimson Roses, and side dishes of pink and common Roses, with a few light sprays of Polyantha Roses. This was very pleasing for its simple, graceful, yet effective appearance. Mr. E. Sperling, 140, Southampton Row, was third, yellow and purple Irises and white Water Lilies being the chief features.

Only two prizes were awarded in the class for an arrangement of foliage and flowers suitable for a side-board, Mr. C. Handley, The Elms, Stoke Newington, having the best contribution, consisting of an arch of Loniceera areca reticulata with two dishes of yellow Sultans and light-coloured English Irises, very pretty and distinct; Mrs. Bengafield, Wandsworth Road, followed, having Liliun speciosum and Gladiolus Colvilli albus with foliage. In several other classes for groups of plants for tables or recesses, Mr. Walter Wood, Mr. J. Prewett, Mrs. Sperling, and Messrs. Dick Radclyffe & Co. were the prizetakers, but their efforts do not call for special notice. Mr. A. Parmley was awarded chief honours for a standing basket, in high foliage plants were gracefully arranged; while for a hanging basket Mr. Chard was an easy first, followed by Mr. J. Anderson and Mr. C. Handley. In the bouquet classes, Mrs. White, 403, Strand, won the chief prizes for both bridal and ball-room bouquets, but we considered Messrs. Perkins & Son's second prize bouquet in the latter class superior to the first.

Miscellaneous exhibits comprised two extensive and handsome groups of Roses from Messrs. Wm. Paul & Son, Waltham Cross (large silver-gilt medal); a magnificent group of flowering and foliage plants from Mr. B. S. Williams, Upper Holloway (large silver medal); and an excellent collection of annuals in pots from Messrs. J. Carter & Co. (silver medal).

#### LOXFORD HALL SEEDLING AND OTHER STRAWBERRIES.

I HAVE this year grown Loxford Hall Seedling for the first time, and am very much disappointed in it. With me it has produced a heavy crop of large fruit, handsome but hollow, and as tasteless as James Veitch. I doubt whether it would do for a market Strawberry, as no one would try it a second time. Dr. Hogg and Filbert Pine are—though carrying a light crop—as usual first rate; I know none to equal them

as mid-season and late varieties. I wish I knew of an early one fit to plant with them. Keen's Seedling is too small, and Marguerite is as tasteless as Loxford Hall. I do not know Sir Harry or Reeve's Eclipse, are they good? Vicomtesse Hericart de Thury bears so freely that the berries come very small. Pioneer is no good in dry weather, and generally fails its second season.—J. E.

#### DOUBLE IVY-LEAF PELARGONIUMS.

MR. WARD'S list of these does not include one of the most lovely and perfect of these attractive flowers. I refer to Fürsten Josephine von Hohenzollern, a pip of which I enclose. As this variety is certain to become a standard sort, I would venture to suggest that its name, however sweet to German ears, might be contracted and anglicised to Princess Josephine. M. Lemoine, of Nancy, has this year distributed a series of novelties. Of these I have flowered Galilée, Laplace, and Gay Lussac. The colours are distinct, habit of plants good, and pips generally very large—some of them over 2½ inches across.

We have some handsome plants of Congo, Mons. Thibaut, &c., grown in 8-inch pots, which measure 3 feet or more across, and full of bloom. These have been kept pinched. Unfortunately cut trusses of these carry badly, but in time, and no doubt shortly, this fault will be remedied.

It is only fair to say that most of the sorts in cultivation have originated on the Continent.—B.

[The blooms sent are extremely fine, nearly 2 inches in diameter, and symmetrical in form, with imbricated petals. The variety is evidently meritorious.]

#### SUMMER TREATMENT OF VINE BORDERS.

It is frequently asserted that it is almost impossible to give Grape Vines too much water or too much liquid manure at the roots, and under certain conditions this may be correct. It is, however, misleading, as I shall endeavour to prove. When the Vines have been several years in undisturbed possession of the borders they will have exhausted whatever fertilising property it originally contained, and stand in great need of external assistance. More often than not, however, old borders are poisoned with manure, and rendered congenial to the roots, these finding their way to better feeding ground. When this happens all or nearly all that is expended on the border in the shape of rich mulchings, of solid manure, dressings of bone and artificial manures, and frequent drenchings of water are thrown away, and only serve to render the soil still more sour and inert. Where this state of affairs prevails no amount of lime or other remedies are of much avail, and nothing short of breaking-up the greater portion of the old border and relaying the roots in a fresh and more wholesome compost will restore the Vines to a healthy profitable state. The more these comparatively useless borders are fed and watered the greater the certainty of the crops ripening imperfectly, shanking wholesale, and keeping badly. If plenty of roots cannot be found near the surface of outside borders the chances are no water is needed, the roots running deeply, having few or no fibres, and having more moisture than is good for them within reach. All that can be done in such a case at present is to crop lightly and to avoid sharp forcing. Let the crops ripen slowly, and reserve the fire heat for the autumn, when its ripening influence will greatly benefit the wood.

If there are no roots on or near the surface of an inside border, in all probability they have struck downwards in search of food that should have been at their disposal on the surface. Inside borders of long standing are not often poisoned with manure; on the contrary, they usually fare badly, hence the rush of the roots for the outside borders that are frequently connected with those inside. Cultivators with a fairly good water supply, and who are fully aware that it must be judiciously applied to the borders, may well have their Vines rooting wholly or partially inside the house; but those who have a poor water supply, or who are either careless in the matter or who imagine two or three soakings in the year are ample, ought to plant in outside borders only. It is true in the latter case, a greater difficulty is experienced in keeping the Grapes after they are ripe owing to there being too much water in the border, but a little extra fire heat and a good circulation of air will go a long way towards dissipating this surplus moisture taken up by the Vines thereby, and checking a rapid decay of the berries.

Newly formed borders, or those which have been partially renewed with fresh compost, are the most liable to be injured by either too much water or too much liquid manure. To treat these similarly to old well-occupied borders, or in accordance with the theory that it is impossible to give them too much moisture or manure, is, to say the least, a most reckless proceeding. It is a very little food that the Vine roots are capable of assimilating, and that little almost any kind of turfy loam contains. To add a quantity of rich solid manure, or a heavy addition of any kind of special manure, only serves to render it more unsuitable as a rooting medium. Unlimited supplies of strong liquid manure serve to make matters worse. It poisons the

soil and kills the roots wholesale. I have seen young Vines refuse to make any progress in quite a new border on which, during the winter, several rows of Cinerarias were grown. The latter we were ambitious to bring to perfection, and, as might be expected, used liquid manure from the farmyard varied with artificial manure very freely. We had a fine display of Cinerarias and ruined the border for the time being. A bank of Show Chrysanthemums once proved quite as injurious to a nearly new inside border, and I could point to a border rendered most unsuitable for Vines by clear water principally, this being applied to Azaleas and various other plants stood on it during the winter. A large well-constructed border needs little besides clear soft water for at least four years, and my experiments tend to convince me that at no time do the roots take up much other than water. They certainly require a little manure, which ought always to be within their reach, but directly we commence giving them extra strong doses the work of poisoning the border is begun, and a healthy root action checked. Follow it up, and shanking and other evils are the almost sure consequence.

Doubtless a Vine's decadence may sometimes be traced to the poverty of the border, but in very many cases the mischief has been brought by the very opposite conditions. Those great Vines at Longleat were built up with the assistance of very little manure, nor was the loam of good quality. A freer use of manure might have pushed them along more rapidly, but would they have lasted in such splendid health so long? They certainly get more manure now, and they respond to the more liberal treatment, Mr. Pratt being in a position to point to a still better lot all through than previously. With better loam and with the experience gained Mr. Taylor is building up his Muscat of Alexandria and other Grapes more rapidly at Bath than at Longleat, and remarkable Vines they are likely to prove. Now, I think I may safely assert they have not received much if any manure, and it is very certain the border has not been poisoned with manure supplied to pot plants stood on the surface. I am well aware that the market growers round London, at Worthing, and elsewhere give large quantities of manure to their Vine borders, and they succeed in growing enormous crops on quite young Vines, but I am told very little other than common garden soil is used, certainly not much good turfy loam. They go in for a short life and a merry one—in other words, they crop so heavily as to soon cripple the Vines (and that too in spite of the abundance of water and manure) when out they come and in go a fresh lot. Private gardeners cannot follow their example, but most go to work slowly but surely.

When would you supply water? some may reasonably inquire, and I will anticipate their query. I would never let either an inside or outside border become really dry, but during the winter and up to the time the roots are active we may easily give them too much. Why, even pot Vines may be ruined by having too much water before the young roots are forming, this being especially the case with those receiving a fresh shift either in the autumn or early in the year. Too much water sours the fresh soil before the roots are in possession, and the consequence is the loss of these as well as the older ones, and the change of the foliage to a yellowish green. If well-drained pot plants suffer we may reasonably assume still worse consequences may follow overwatering a new border. A Vine border ought to be frequently examined, and when approaching dryness be watered. No harm is done by probing to a good depth, and it does not require an expert to decide if the soil is in a fit state to receive water. If it binds in the hand when pressed none is required, but if it crumbles readily it may be given. If applied before it becomes dust dry a very moderate amount suffices to moisten it thoroughly, but if it is delayed till the soil is dust dry, then large quantities, or the thousands of gallons we sometimes read about being necessary, is required. When the borders are very narrow or shallow, or are being formed piecemeal, they need much more water, and if the soil is not fresh liquid manure of some kind frequently. Any under glass that have been formed several years and now well filled with roots also require abundance of water as well as some manure, nothing being better than a surfacing of good loam, burnt garden refuse, and partially decayed farmyard manure. Jensen's fish-bone manure and Thomson's Vine manure are both very valuable for surface dressing or for mixing with the compost. Only a little at a time should be used, as the roots that both manures seem capable of attracting to the surface are easily injured by them. The borders being duly mulched with straw manure do not so quickly become dry, and fortnightly waterings are, as a rule, quite often enough, no matter how hot the weather may be. We have drains to our borders, but it is not often much water passes through them, for the simple reason that by anticipating dryness not much water or liquid manure is needed to moisten it sufficiently.

Outside borders as yet have needed but little water, ours receiving a soaking close to a dry wall only. We treat them exactly the same as those inside. When found to be dry they are watered, and they also receive a little of Jensen's manure, as well as a mulching of

straw manure. Heavy and repeated doses of water and liquid manure would cause the berries to shank badly, and on the other hand, if allowed to get too dry, the berries would colour badly, and other evils also result.—W. JGGULDEN.

### CUCUMBERS—ARTIFICIAL MANURES.

I HAVE been growing the following varieties of Cucumbers this summer, and I now send the result of my experience with them.

Rollisson's Telegraph stands first in my estimation for quality, cropping, and general usefulness, but everyone knows it so well that I need only say it pays me best, for I have cut double the quantity of good sized fruits from Rollisson's than of any other variety.

Gilbert's Burghley Pet stands next as a paying Cucumber, all the fruits being of good length and of exceptional thickness. The neck is short, the skin dark, and the quality all that could be wished. I have got a better price for the fruits than for Rollisson's, but the latter is the better cropper.

Sutton's Improved Telegraph I found slow in coming into bearing, and not nearly such a good cropper as Rollisson's. It is, however, a handsome fruit and large.

Cardiff Castle I saw so highly praised that I determined to try it, but I am not very pleased with it. It is certainly a good cropper, and the colour is dark and the fruits handsome, but they are too short, and I find they do not sell nearly so well in a profitable sense as Rollisson's and Burghley Pet.

A friend sent me two packets of seed, one marked "Telegraph," and the other "Ward's Telegraph." The former I found of the Telegraph type, but not equal to the true Rollisson's, and the latter I never wish to see again. It is a most peculiar fruit, quite one-third of it being neck, and a very thin neck too. I at first thought the first two fruits were grown out of form, but every succeeding fruit has been the same.

I may add that I have succeeded far better with Cucumbers this year than I have before, and I ascribe the better cropping and finer fruits to the use of Jensen's Fish Potash Guano. I bought some of this manure to apply to my land for a crop of Oats, and I may here say that they look remarkably well, and the farmer who had the land last year is surprised to see such a good piece of Oats. Having some quantity of the manure left I have frequently used it as a top-dressing to my Cucumbers mixed with soil, and have also watered it in. Previously I have always used liquid manure, preferably that made with sheep droppings, but in future I shall content myself with the Fish Potash Guano, which is less troublesome to prepare and use. I have also applied this manure to Gloxinias, and *Lilium auratum*, also to Tomatoes and Peas, and I have seen the beneficial effect on them.—H. S. EASTY.

### TUBEROUS BEGONIAS.

I SHOULD much like to have the experience of others who have gone largely into the culture of the above. I have had them bedded out eight years; first the common ones, then many named sorts from Messrs. Laing & Co., grown one year in conservatory; and since then I have placed out many good varieties in beds. Many of my tubers are five, six and seven years old. Last season I noticed considerable deterioration in all, not being anything like so floriferous as in preceding seasons. Each year I consider I have had them both in beds and conservatory rather better in every way, as far as culture goes, than the first two or three years. I remark a deterioration in flowering of some of the best sorts, such as Dr. Masters, Prince of Wales, Empress of India, Madame Crousse, Comtesse H. de Choiseul, and other high-priced ones of this class. Last season, in the tropical heat of June and July, the leaves of those bedded out were attacked for the first time by some insect of the weevil tribe, and I had before August to cut off all the eaten large leaves. When rain came the plants recovered their foliage, and bloomed fairly well all the late autumn. Two or three plants were attacked in a vinery.

I have always been very successful in keeping all sorts through the winter, rarely losing more than one or two. This last spring I found six of those seven or eight-year-old corms did not start like all the others, laying on their sides in pots under boards at the back wall of the vinery. No damp was near them, but on examination I found them decayed but dry. I have never lost any kept in boxes, packed in wine cases in layers of cocoa-nut fibre refuse. I should like to hear from some amateur growers how long they consider Begonias last before showing deterioration in blooming, all things being done perfectly from the first flowering of the seedling. I have come to one conclusion, that Begonias, like most plants, deteriorate after their third season of flowering, no matter how well they are done, winter, spring and summer.—SAXORING.

RASPBERRIES AND THE DRY WEATHER.—The long drought has quickly left its mark on the Raspberries, and the fruit, though very



plentiful, promise to be exceptionally small. Very heavy rains would be needed to well moisten the ground, and in any case we advise good waterings being given for two nights in succession. A mulching of either strawy manure or lawn grass ought to be given, unless this has been already done. A marked improvement in the quality of the crop will soon follow this treatment. It is advisable to also freely thin out the young canes, leaving as many only as are needed for fruiting next season.

### WATERING ROSES.

ALARMED by the extraordinary drought of last month I made efforts to afford my Roses, a small number in a small space, regular supplies of water—hard only—but always well tempered by long standing in the sun. At least three times a week the Roses were liberally supplied at the roots with sufficient quantities of water, without interfering with the delicate roots. Wide channels were made, which were patiently and continuously filled and re-filled till the ground was well and deeply soaked. At the same time, or just after, each tree was carefully watered over the foliage also with tempered water, and when the sun was off. The result has surpassed my expectations; my Roses are better, cleaner, finer in bloom and foliage than I have ever seen them, and have won high encomiums from others, as well as from their gratified attendant—A. M. B.

### PACKING FRUIT FOR TRAVELLING.

A CORRESPONDENT having desired us to publish the "instructions that were issued several years ago by the Pomological Society," we have, after some trouble, discovered them, and comply with the request:—

"Fruit should be protected against injury from pressure, by being packed in boxes or stout baskets; very light baskets, and frail, are frequently used, and damage more or less is invariably the result.

"Against injury from shaking, or turning over, it should be guarded—Firstly, by using cases of moderate dimensions in every direction, or larger cases with partitions in them, that there may not be too great a hulk to move about within the package; secondly, by laying the separate articles so closely and compactly together that they shall just keep each other steady without crushing. This last is, perhaps, the most important matter of all—no fruit suffers so much as that which is loosely packed. Common sense, of course, dictates, that in packing soft and solid fruits in the same case the latter should be laid in the bottom; if, however, the box is turned upside down on its journey, this arrangement becomes valueless; and, to guard against such casualties, horizontal partitions of thin deal should be dropped into the box between layers of soft and solid fruit, and secured in their position by nailing or otherwise.

"Fruit is also frequently damaged in flavour by being packed in moss, brown paper, straw, or hay chaff, or other substances which impart their aroma and flavour to all delicate and absorbent fruits which are surrounded by them. If such materials are used, the fruit should be separately enclosed in tissue, cap, or writing paper, cotton wool, leaves, or other scentless material.

"The bloom of certain fruits is best preserved if they are packed in young Nettle-tops, partially dried. Stout cartridge paper is also excellent for the purpose, as it keeps them steady, without pressure upon more than a small portion of their surface, and its stiffness prevents crushing.

"Pine Apples travel with least injury to the crown if folded up in a piece of stout cartridge paper, and firmly but not tightly secured by matting.

"Grapes carry best if tied down to the bottom of a shallow box, in the manner first used by Mr. Fleming, of Trentham, at the London exhibitions. The next best method is to enclose each bunch separately in a piece of stout cartridge paper—folding it somewhat like a grocer's pound package of sugar—and placing them as close together in a box as they will lie without crushing.

"Melons should be enclosed in cap paper, placed in a box, and surrounded by chaff, bran, or dry sawdust.

"Peaches, Nectarines, and Apricots should be carefully enclosed in a piece of tissue paper, and kept separate from each other by cotton wool. The two former when sent to be named should always be accompanied by leaves; and information should be sent as to the size of the flowers, whether large or small.

"Plums, when the bloom is important, should be rolled up, six or eight together, in a piece of cartridge paper, and tied round with matting. When the bloom is not important, they may be packed in Strawberry or similar leaves. The first should always be accompanied by leaves and wood.

"Cherries, Gooseberries, and Currants travel very well under general circumstances if laid together in small shallow baskets or punnets, covered with leaves, and tied over with paper.

"Strawberries, Raspberries, and Mulberries should be packed in shallow boxes or punnets, each fruit being separately surrounded by one or two Strawberry leaves."

### STYRAX JAPONICA.

SEVERAL varieties of the officinal Storax, *Styrax officinalis*, have been known in gardens for many years, and are ornamental in no ordinary degree where they succeed, generally producing their white

flowers freely against walls or in warm sheltered positions. The Snow-drop or Silver Bell Tree, *Halesia tetraptera*, is a near relative of these plants, and the species—*Styrax japonica*—represented in the woodcut (fig. 3), is as much entitled to the two former popular names as the *Halesia*. The pure white, bell-shaped, drooping flowers are very suggestive of Snowdrops both in size and substance, and have a charming appearance. Messrs. J. Veitch & Sons, Chelsea, exhibited specimens of *Styrax japonica* at a recent meeting of the Royal Horticultural Society at South Kensington, when a first-class certificate was awarded for it. The tree thrives well at the Coombe Wood nurseries, where it has proved hardly near a wall, and has attained a height of 12 feet. It seems



Fig. 3.—*Styrax japonica*.

rather quicker and more free in growth than *Styrax officinalis*, which is extremely slow, even in favourable situations.

### SHADING AND AIR-GIVING.

HAVING received several examples of scalded Grapes and scorched foliage of late, with requests to point out the cause of the injury and methods of prevention, we print the following article that was prepared by a gardener of great experience, and who has treated the subject more fully than we could do in the form of replies to inquirers:—

Few things are more bewildering to young beginners in exotic plant cultivation than shading; and to amateurs, whose chief physical engagement is connected with attention to their plants only on mornings and evenings, there are few matters more marked by perplexing and uncheering disappointments. Gardeners, in large places, and men of business, with their pet single house, have often alike to complain of want of thought in the case of their, no doubt, well-meaning coadjutors. Neglect of giving air early enough, and then a burst of it, after the house has been steamed up with sun heat and vapour ever so high, will produce results, less or more analogous to pouring among pot plants a blast of hot air from a furnace, just in proportion to the difference in temperature and moisture inside and outside of the house. One of the best known and most successful gardeners of the day, told me recently

of a splendid house of Grapes, the greater part of the bunches of which had been completely scorched from this cause alone. Air was neglected in a very bright day, and then a sudden rush admitted. He aptly said—if the house had been shaded, plenty of moisture thrown about on paths, stages, &c., and then only a very little air given, when the house began to cool, the mischief would have been avoided. As a preventive remedy for all cases, and especially applicable to gentlemen who are absent from home during the day, and cannot depend thoroughly upon shading, nothing is so effectual as never taking the whole of the air away, night or day; or, if for the sake of heat, it is removed at night, to be sure to give air at the back of the pit or house early in the morning. The heat of the house, from the power of the sun, thus increases gradually; there is no sudden accumulation of scalding vapour, and the strong constitution, from the low temperature at night, enables the plant to regale itself in a temperature at mid-day without any shade, which would be destructive to one coddled up in a high temperature at night, or with air given at breakfast time, after the sun had been playing on the glass for hours.

This early or continuous air-giving, is, therefore, to a great extent, a substitute for all the bother and litter of shading. We thus, likewise, in most cases, place the plants in the circumstances they would realise in their natural climates. This is a matter of importance to all who follow gardening in large towns. The night and morning air is ever the freest from sooty exhalations. The more given then, the less will be required during the day. Instead of a difference of some 5° or 10° between the temperature of night and day, many of the plants we cultivate, enjoy, in their natural wilds, a difference of 30° or 40°.

I fully acted on this principle when I gardened in London many years ago. Even then I could do no great things with Pelargoniums, Epacris, &c., without shading from very bright sun, and a very free application from the syringe at all times, just saving the bloom as much as possible. But I found little difficulty, except my comparative ignorance, with any plants requiring heat—such as stove plants, Cucumbers, Melons, Pines, Vines, &c.; and these had seldom shading, except during sudden changes from dull to bright weather. During early spring, even in bright days, the air was not vastly increased, because it brought so much soot with it, but additional moisture was given to the atmosphere, and air was either left on all night, or given early in the morning. After shutting up early in an afternoon, I have often given a little air to the tops of all my sashes at bedtime, and increased that but little during the day, until the atmosphere of summer came. In a vinery, for instance, it was no uncommon thing to have a difference of 40° between the house at midnight, or an hour or two after, and the same house, with a bright sun, in March or April, at noon—the temperature ranging from 50° to 55° in the one case, and from 85° to 95° in the other. The fertility and luxuriance proved the treatment to be right. Such a difference taking place suddenly would have been ruinous with such a small amount of air and no shading: the air at night, or early in the morning, caused the temperature to increase gradually. The expanding and assimilating powers acted, therefore, in unison. No little money was also saved in fuel and shading-cloths.

These remarks will meet the case of several recent inquiries. In most towns of moderate extent any plants may be cultivated in summer, unless there are pestiferous fumes emitted from some neighbouring manufactory. But in the centre of such Babylons as London, or even of Manchester, Glasgow, &c., a vast deal of labour in washing, &c., will be requisite to keep during the year the denizens of the greenhouse. No one likes to cut away their own standing ground, and yet honesty compels me to say, that the plants that mostly come under my department of labour cannot be maintained in vigorous health, in such circumstances, without a great amount of care and labour, and hardly even then. The thick smoky fogs in winter, unless great care is taken in watering, will fill the stems with watery juices, the precursors of hosts of insects. If you open the sashes the plants will get a saline sooty incrustation. If you keep them shut, and shade in a bright day, the plants become weakly and drawn. Your chief remedies are—thin bunting, a fine gauze wire over the air apertures, to help to sift out the soot, and a free application of the sponge and syringe to the foliage. Where this labour is deemed too much, with the exception of Pelargoniums, Fuchsias, succulents, and a few others, which remain at rest during the winter, it will be the most satisfactory to have the place fresh furnished, or partly so, every spring.

This last mode, however, would lessen the pleasure of having plants of one's own growing. For these there are two classes of plants peculiarly applicable. The first of these are hardy plants, chiefly of an herbaceous character, and requiring in winter similar protection as that afforded to alpins—namely, protection such as a covering of snow would render, which is well imitated by thick

glass cases on the top of a house even, and, in severe weather, the benefit of a tarpaulin. For months during the cold season, no further care would be necessary than a little air in fine weather, to keep the atmosphere sweet, and prevent moulding and damping. If the pots are plunged, little of the water-can will be required from November to March. After that period more air would have to be given, and then, in April and May, the whole lot may be turned out of doors, unless there are a few very delicate and rare. The other class would suit those who can afford all the paraphernalia of a well-arranged plant stove.

(To be continued.)

### DESCRIPTIONS OF AURICULAS.

IN our issue of the 9th ult. (page 459) an esteemed correspondent, the Rev. F. D. Horner, suggested the publication in this Journal of the Rev. George Jeans' vivid and concise descriptions of Auriculas twenty-five years ago, and kindly offered to lend the volumes of "Gossip of the Garden" containing them for the purpose. Other correspondents having expressed a similar desire, and Mr. Horner obligingly furnishing references to Mr. Jeans' notes, we find the volumes in which they lie entombed in our library, and have pleasure in acting in compliance with the desires of old and new growers of the Auricula.

We print in slightly abridged form Mr. Jeans' introduction to his descriptions as follows:—

I HAVE a disadvantage as an Auricula grower as compared with the Lancashire patrons of the flower, that so far as I know I stand alone in my county as yet, though there are some springing up around me from whose collections I may some day glean instruction and pleasure. At present I am obliged to swell my list to an inconvenient number, and consequently to increase my labour and expense proportionally, in order to compare varieties and estimate excellencies. Even now I have above 100 sorts, from which I cannot discard many; and several that were heretofore weeded or lost must be replaced, as well as new ones added. But owing to this I find myself gradually acquiring a better knowledge of the peculiarities both of the flower generally and of each variety in particular. No two people probably altogether agree in taste. It is discernment I am speaking of; and with reference to that, the disadvantage I allude to is of service to me as a means of improvement. I have been called to account by several writers, nor can I expect to be always right; but as I have advanced nothing but what has passed under my own eye in the actual culture of each variety, and with a pretty large assortment too under my care, I am sure that I have made no mistake in the facts from which the conclusions were drawn, for locality makes a considerable change in many flowers; but this I know that my descriptions were taken from the close observation of not one day or two, corrected from time to time as changes took place, or as my eye became more familiar with them. And I have commenced a series of short descriptions of all I possess, which are at your service if you think them worth printing. The form resembles that adopted by botanists, to give in order a short account of each point of difference whereby the subject differs from other kindred subjects.

I never had, nor have I elsewhere seen, such a bloom as I had this year (1860). And as some sorts that do not commonly rank particularly high rose to the first degree of excellence I will subjoin a list, in the order of their superiority, of those out of which in each class my selection for exhibition would have been made.

#### GREEN EDGED.

- 1, Heady's Conductor.
- 2, Olliver's Lady Ann Wilbraham.
- 3, Smith's Lyncurgus.
- 4, Lightbody's Star of Bethlehem.
- 5, Dickson's Matilda.
- 6, Hudson's Apollo.

#### GREY EDGED.

- 1, Chapman's Maria.
- 2, Maclean's Unique.
- 3, Wilmer's Squire Chilman.
- 4, Waterhouse's Conqueror of Europe.
- 5, Lancashire.
- 6, Grime's Privateer.
- 7, Lightbody's Sir C. Napier.

#### WHITE EDGED.

- 1, Heap's Smiling Beauty.
- 2, Taylor's Glory.
- 3, Taylor's Favourite.
- 4, Taylor's Incomparable.
- 5, Hughes' Pillar of Beauty.
- 6, Popplewell's Conqueror.

#### SELFS.

- 1, Martin's Mrs. Sturrock.
- 2, Sims' Vulcan.
- 3, Spalding's Blackbird.
- 4, Faulkner's Hannibal.
- 5, Lightbody's Meteor Flag.
- 6, Martin's Eclipse.
- 7, Smith's Mrs. Smith.

These, as may well be supposed, are not all the sorts that were fit for the exhibition table, nor could I at any one time have shown all these together as one lot. What I mean is that they were the best of the year, and in that order of excellence. Those which stand first respectively in each class were such as to justify a little of our proverbial enthusiasm.

#### GREEN EDGED.

*Ashton's Prince of Wales.*—A moderate second-rate flower. Pip slightly undersized, flat, starry; edge impure, otherwise good; colour chestnut, narrow, angular; paste medium quality, fair breadth, angular; eye somewhat full, orange; anthers even with surface; fair trusser; foliage abundant, light green, serrated.

*Beeston's Apollo.*—A good second-rate flower while it lasts, but both in foliage and bloom it is flimsy (mouse-eared) though of good constitution. Pip circular but angular, flat; edge pure, vivid grass green; colour

violet, of proper breadth; paste good, circular; eye pale yellow, which bleaches soon; anthers hidden; carries a well-shaped truss of nine. Foliage light green, of thin substance, but shapely and handsome. An immoderate breeder.

**Booth's Freedom.**—Of tender constitution and very impatient of any neglect or mistake. Where number of pips are not regarded, or where sufficient may be obtained, and it seems that they may be obtained, this must still be admitted to be the best green-edged flower. Pip circular, sufficiently flat; edge the purest and best of all the greens, contrasting strikingly with the intensely black body-colour which is of sufficient breadth and boldness; eye of proper size, greenish yellow, closed with the stamens (not the anthers), has a weak small stem, and rarely produces more than four pips. Foliage veined, deep green, curled, not serrated.

**Buckley's Jolly Tar.**—Pip full sized, broad petalled, tolerably flat, pointed; edge vivid green, pure; colour dark mulberry, much too narrow; paste circular, of good substance, whiter than most, almost in excess; eye too large, orange, anthers above surface. Truss good. Foliage light green, handsome. May be admitted into the second-rates.

**Campbell's Lord Palmerston.**—One of the immoderate breeders, with smooth glossy foliage of medium tint of green, and robust health. Pip flat and round but slightly pointed, and with petals too small; edge apple-green, beaded; colour nearly black, of sufficient breadth; paste even, well defined, too narrow; eye lemon, large, round, closed by the stamens not anthers. A pretty second-rate flower, not unlike a bad Booth's Freedom.

(To be continued.)



AT a general meeting of the ROYAL HORTICULTURAL SOCIETY, held July 12th, in the Conservatory, South Kensington, Maxwell T. Masters, M.D., F.R.S., in the chair, the following candidates were elected Fellows—viz., Duncan Gilmour, jun., Mrs. Lewis, Fred. John Potter.

AT the meeting of the ROYAL AGRICULTURAL AND BOTANICAL SOCIETY OF GHENT, held on the 20th of June last, Dr. Hogg was elected an honorary member of the Society; "in recognition of the services he has rendered and still continues to render to botanical science." Last year His Majesty the King of the Belgians conferred the honour of the Cross of the Order of Leopold on Dr. Hogg, but coming through the British Embassy at Brussels, he was prohibited from accepting it by regulations of the Foreign Office.

THERE was a considerable attendance at the STRAWBERRY FETE AT CHISWICK last Saturday afternoon, and the day being hot the demand for fruit was so great as to almost over-tax the "pickers." A large marquee was erected for the comfort of visitors, and the boys' band from the Duke of York's school gave general satisfaction. The evening was enjoyably spent by those present, and Strawberries were getting scarce after seven o'clock. Sir Joseph Paxton, President, and Sir Charles Napier were the leading varieties, the first named being the finest in appearance, the last the best in quality. Among the newer varieties on trial, Countess is perhaps one of the richest in flavour, the fruit being of good size and deep crimson in colour. We may expect, however, that a report of the Strawberries will be prepared for publication at some time, and it would be useful.

AT the OXFORD ROSE SOCIETY'S SHOW on Tuesday, the 12th inst., the National Rose Society's gold medal for the best stand of Roses exhibited in the open classes was awarded to Mr. W. J. Grant, Ledbury, and the silver-gilt medal competed for by amateur members of the Society was won by Mr. Wm. Narroway, Headington Quarry, Oxford. The silver medals for the best H.P. and the best Tea or Noisette blooms were awarded for the former to Mr. H. Evans, Marston, Oxford, for Mdle. Marie Rady, and for the latter to R. Ramsden, Esq., Chadwick Manor, Knowle, for Maréchal Niel. The two first-mentioned medals being given by the President of the Society, G. Herbert, Esq., Headington Hill Hall, Oxford.

STRAWBERRIES AT BATH.—Prizes are offered for Strawberries in connection with the Bath Rose Show, but outsiders would not have been surprised if these had not been so keenly competed for as usual. As it happened there were more staged than usual, the competition being

good in every class, and many of the dishes were very fine indeed. Several varieties, new and old, were shown, but all were eclipsed by the good old Sir Joseph Paxton, this being extra large and good, and no other variety much surpasses it either for firmness, travelling properties, or flavour. President and Sir C. Napier were also very good, and Eleanor, Newton Seedling, and Clipper were fairly well represented. The principal prizewinners were Messrs. T. Evrey, M. Tiley, W. Scott, W. G. Tilec, E. T. Hill, and E. Fisher.

THE best Cauliflower in the Chiswick trials recently was DEAN'S SNOWBALL from home-grown seed. It is a carefully selected form of the Early Erfurt, and showed to great advantage by the side of a plantation from imported seed. The heads appeared as if resting on the ground, and the plants as uniform as if cast in a mould.

MESSRS. W. LOVELL & SON, Strawberry Growers, Driffield, send us a box of STRAWBERRIES. They consist of Sir Joseph Paxton, Filbert Pine, President, and Dr. Hogg. We are told they were gathered from one-year-old plants put out on a bed after Potatoes, and which, in spite of the very dry weather, have yielded an abundant crop. The fruit is very fine indeed, particularly so under the circumstances.

DEATH OF MR. T. HASTIE.—A Lanarkshire correspondent sends the following—"It is with deep regret I have to announce the death of an old friend, florist, and bee-keeper, THOMAS HASTIE OF CRAIGMILL, STRATHAVEN, which occurred on Monday the 4th current in his seventy-ninth year. For nearly seventy years he has been a keen florist, Pinks being his first fancy when a boy at school, and Auriculas were his favourites in his mature years. Mr. Hastie was a Justice of the Peace for a long period, was highly respected, and widely known. He read all the popular papers on horticulture, and encouraged all with whom he was acquainted, particularly youths, to fill up spare time by reading. In his early years he was associated with the late Mr. Pettigrew's father. He leaves a widow to mourn his loss, but no family."

"D." writes that "LOBELIA DUCHESS OF SUTHERLAND is by far the best white Lobelia of the Erinus section I have seen. Messrs. John Laing & Co. have it planted out at their Forest Hill Nurseries, and it is just as free and good as the best strain of speciosa, and with snow-white flowers."

MR. R. P. BROTHERSTON sends us from Tynninghame a shoot of CHRYSANTHEMUM MADAME DESGRANGES, which has been in flower since May, and observes:—"We have had good bushes, and the bunches of bloom have been very serviceable for sending to London. These plants bloomed late last year out of doors, then after lifted and grown under glass, and now after flowering will be treated so as to furnish another crop at the ordinary season." The stem had seven large pure white flowers, equal to those produced in the autumn, and the foliage was similarly fresh and healthy. They were packed in green Fern fronds, the common Braeken, and arrived as fresh as if just severed from the plant.

AT a recent meeting of the BELGIAN HORTICULTURISTS IN GHENT the following members were present: MM. Jules Hye, Ern Delaruye, Baudu, L. De Smet-Duvivier, Fr. Desbois, A. Rosseel, C. Spae, Raphael De Smet, Jules de Cock, and Em. De Cock, with M. Alexis Dalliére in the chair, and M. Victor Cuvelier as Secretary. Certificates of merit were awarded for *Cypripedium Schroeckerae*, from M. James Bray; *Begonia* Mr. Hardy, from MM. Fr. Desbois & Co.; *Cypripedium Sedeni candidulum*, and *Cypripedium Schroeckerae*, from M. Jules Hye; *Coleus Monsieur Lemoinier*, and *Spiraea astilboïdes*, from MM. F. Desbois and Co.; *Odontoglossum vexillarium album*, from M. L. De Smet-Duvivier; *Odontoglossum (Miltonia) vexillarium var.*, from MM. Vervae & Co.; *Odontoglossum crispum*, *Cypripedium selligerum majus*, and *Oncidium maeranthum hastiferum*, from MM. Vervae & Co. A cultural certificate was awarded for *Adiantum dolabriforme*, from M. Aug. Van Geert; and honourable mention for *Metrosideros floribundum rubescens*, from M. B. Spae; *Aralia Chabrieri*, from M. le Comte Paul de Hempinne; *Polygala Dalmatisiana*, from M. Aug. Cornelis; *Cypripedium Stonei*, from M. Arth. De Smet; *Restrepia pardina*, from M. Jules Hye; *Cypripedium Ræbelini*, *Tillandsia Sieboldiana*, from M. le Comte P. de Hempinne; *Tuberous Begonia*, from MM. Smeding & Van Exter; *Cypripedium selligerum*, *Odontoglossum lyroglossum*, *Cattleya Mossiae*, from MM. Vervae & Co.; and *Genista racemosa*, from M. Auguste Cornelis.



— We are informed that the FLORAL DECORATIONS at the recent ceremony at South Kensington, when the Queen laid the foundation stone of the Imperial Institute, were executed by Messrs. Wills and Segar, Onslow Crescent. Large numbers of flowering and foliage plants were employed, and the effect produced was highly imposing. The same firm has also carried out the decorations at Arcadia (Agricultural Hall), Islington, where a picturesque effect has been produced by forming beds of foliage and flowering plants, with sloping walks, terraces, &c.

— In the note on LILAC MARIE LEQUAY last week it should have been stated that the trusses figured were received from Messrs. Wm. Paul & Son, Waltham Cross.

— GARDENING APPOINTMENT.—Mr. J. T. Ashlee (late foreman to Mr. J. Lessels, deceased), has been appointed head gardener to Sir T. F. Boughay, Bart., of Aqualate Hall, Newport, Salop.

— THE following summary of METEOROLOGICAL OBSERVATIONS AT HODSOCK PRIORY, WORKSOP, NOTTS, for June, 1887, has been sent to us by Mr. Joseph Mallender:—Mean temperature of month, 59.1°. Maximum on the 27th, 83.5°; minimum on the 21st, 36.3°. Maximum in the sun on the 12th, 139.6°; minimum on the grass on the 21st, 28.0°. Mean temperature of air at 9 A.M., 61.2°. Mean temperature of soil 1 foot deep, 58.8°. Nights below 32°, in shade 0, on grass two. Total duration of sunshine in month 219 hours, or 44 per cent. of possible duration. Maximum in one day on 23rd, 14.7 hours, or 88 per cent. of possible duration. We had one sunless day. Total fall rainfall 0.22 inch. Maximum fall in twenty-four hours on the 2nd, 0.09. Rain fell on three days. Approximate averages for June—Mean temperature 57.1°; rainfall, 2.36 inches. Sunshine (six years) 152 hours. The month was warmer, drier, and brighter than any June during recent years. No rain whatever fell after the 3rd. In the May report the maximum should read 71.3 on the 8th.

## ROYAL HORTICULTURAL SOCIETY.

JULY 12TH.

A VARIED and interesting display was provided in the conservatory on Tuesday last, hardy plants, annuals, Tuberosus Begonias, and miscellaneous plants with Peas and Strawberries being well represented.

FRUIT COMMITTEE.—Present: Dr. Robert Hogg in the chair, and Messrs. T. Francis Rivers, G. T. Miles, Alfred H. Pearson, Arthur W. Sutton, Harry J. Veitch, James Smith, T. B. Haywood, C. Ross, Phillip Crowley, Sidney Ford, G. Bunyard.

Mr. W. Allan, Gunton Park Gardens, Norwich, exhibited seven boxes of fine Strawberries, representing fourteen varieties, including the following—Auguste Nicaise, Mr. Radclyffe, Auguste Boisselot, The Countess, President, Dr. Hogg, John Powell, Amateur, Unser Fritz, James Veitch, Sir J. Paxton, British Queen, Sir Charles Napier, and Crimson Queen. A bronze Banksian medal was awarded for this handsome collection. Messrs. James Veitch & Sons, Chelsea, sent several dishes of the large dark coloured Strawberry Waterloo, which were greatly admired, the fruits being large and of good flavour. Stewart Hodgson, Esq., Lythe, Haslemere, showed two fine Pine Apples, fruited in sixteen months from the time the suckers were taken. Mr. C. Ross and W. F. Hume Dick, Esq., Thames Ditton House, sent seedling Melons. Mr. Maher, Yattendon Court Gardens, Newbury, showed a seedling Peach named General Gordon, and two Melons, named Cloth of Gold and Lord of the Manor. Mr. Forman, Louth, Lincolnshire, had several dishes of Strawberries, including Gloria Mundi, Forman's Luda, Victoria, and Recherché.

SPECIAL PRIZES FOR PEAS.—Messrs. J. Carter & Co.'s prizes for four varieties of Peas brought a number of competitors, who had good samples for the season. Mr. H. Marriott, sen., Skirbeck, Boston, was first with capital pods of Telephone, Pride of the Market, Stratagem, and Anticipation. Mr. Marriott, jun., Prospect House, Boston, was second, and Mr. T. A. Beckett, Amersham, third, with the same varieties. There were nine competitors.

Messrs. Sutton & Sons' prizes for two varieties of Peas brought eight exhibitors. Mr. T. A. Beckett, won first honours for Duke of Albany and Royal Jubilee. Mr. R. Timms, Penn, Amersham was second; Mr. C. J. Waite, Glenhurst Gardens, Esher, was third; and Mr. H. Marriott fourth with the same varieties. The same firm's prizes for Magnum Bonum Cauliflowers were awarded to Mr. C. J. Waite, who was first, and Mr. T. A. Beckett third.

Messrs. Webb & Son, Wordsley, Stourbridge, offered prizes for twenty-four pods of Wordsley Wonder Peas, for which seven competitors entered. Mr. H. Marriott, sen., was first, Mr. H. Marriott, jun., second, and Mr. E. G. Wiles third.

FLORAL COMMITTEE.—Present, G. F. Wilson, Esq. (in the chair), Messrs. Shirley Hibberd, W. Wilks, J. Fraser, H. Herbst, Dr. Lowe, G. Duffield, B. Wynne, R. Dean, C. Noble, H. Ballantine, J. Dominy, Major Lendy, T. Baines, J. O'Brien, E. Hill, H. Turner, W. Holmes, and W. Goldring.

Mr. H. Eckford, gardener to Dr. Sankey, Boreatton Park, Baschureh, near Shrewsbury, had a collection of seedling Sweet Peas, comprising

some exceedingly pretty varieties, three of which were certificated. Other pretty varieties were Empress of India, rose and white; Purple King, deep purple; Eliza Eckford, white; and Boreatton, dark crimson and purple. Messrs. H. Cannell & Sons, Swanley, exhibited two beautiful Tuberosus Begonias—Mrs. Lewis Castle, double, and Prince of Orange, single, which were certificated. Mr. Ross, The Gardens, Pendell Court, Bletchingley, was awarded a cultural commendation for six trusses of Lagerstroemia indica, loaded with bright pink flowers. Mr. H. B. May, Upper Edmonton, sent three flowers of Croton Etna, a bold variety, the leaves veined with yellow and red on green. Messrs. Collins Bros. & Gabriel, 39, Waterloo Road, showed a plant of a large variety of Ox-eye Daisy, named Imperialis. Mr. W. Gordon, Twickenham, exhibited flowers of Lilium Krameri, tinged with rose, and several good varieties of Iris Kämpferi. Mr. C. Turner, Slough, had a group of Carnations, the yellow free variety Amber, and the pink Souvenir de la Malmaison, both of which were certificated. F. G. Tautz, Esq., Studley House, Hammersmith (gardener, Mr. C. Cowley), showed plants of Epidendrum atropurpureum var. Randi, Cypripedium tonsum, C. Curtisii (vote of thanks), and C. selligerum majus.

Messrs. John Laing & Co., Forest Hill, were awarded a silver-gilt Banksian medal for a magnificent group of single and double Tuberosus Begonias, comprising a large number of superb varieties, several of which were certificated and are described at the end of this report. The other varieties were the same as those recently noticed in our report of the Begonias at Forest Hill. Messrs. J. Carter & Co., High Holborn, were awarded a bronze Banksian medal for large beautiful groups of annuals, early Gladiolus, varieties of the G. Colvilli type. Very handsome amongst the latter were G. Brilliant, scarlet, with white blotches in the three lower petals; General Grant, pale pink, crimson spots; Blushing Bride, white, with crimson spots; Duke of Albany, scarlet, white spots; and Fire King, scarlet, pale crimson spots, darker margin. The annuals and other plants were very numerous and most tastefully arranged. Some of the most notable plants were Phlox Drummondii varieties, Balsams, Stocks, Tropæolums, Petunias, Godetias, Gaillardias, Poppies, ornamental Grasses, and Eucharidium eocinnium.

Messrs. J. Veitch & Sons, Chelsea, had a group of new and interesting plants, together with several stands of Iris Kämpferi varieties, very rich and diverse in colour. Amongst them the following were noteworthy:—Minnie Palmer, white, veined with mauve, yellow central blotches; Thomas Manning, richly veined with violet purple; Refulgens, intensely deep crimson; Charles Maries, dark rose, veined white; La Grandesse, pure white; Striata superba, delicate mauve, finely veined purple; Lord R. Churehill, rosy crimson; Viceroy, veined and suffused crimson purple; Mikado, violet purple; Christine, veined and tinged purple on a light ground; Harlequin, flaked purple on a mauve ground. Several other good varieties were certificated. They also had plants of the handsome Nephrolepis rufescens bipinnatifida, Anthurium Rothschildianum, the handsome Miconia Hookeriana, a variegated Impatiens Sultani, an elegant variety of Adiantum Capillus-Veneris named Mariesi, the white bell-flowered Andromeda speciosa cassinæfolia, Escallonia philippiana, the peculiar little pink papilionaceous Notospartium Carmichaeliana from New Zealand, and the bright red Clematis coccinea.

Mr. T. S. Ware, Tottenham, was adjudged a silver-gilt Banksian medal for an extensive and handsome collection of hardy flowers, which for diversity of colours and taste in arrangement was one of the best shown this season. Very notable were the groups of Lilies, comprising the creamy buff Lilium testaceum, the bright scarlet L. chalcedonicum, the white L. longiflorum, and the old L. candidum; the long tubed, white with purplish exterior, L. Browni; the intensely dark maroon, L. Martagon dalmaticum; the graceful scarlet L. tenuifolium; the bright yellow, neat, L. Parryi; the rich orange, dotted, L. croceum; the small orange, spotted, L. Columbianum lueidum; L. pardalinum Burgei; L. Humboldti, L. pulchellum, and L. elegans alutaceum were all very fine. Gaillardias were very bright and rich, especially Maxima and Brilliant with miscellaneous seedlings. A basket of the dark purplish blue Tritelia laxa Murrayana attracted much attention, reminding one of Campanula glomerata dahurica. The pure white Malva moschata alba, the yellow Pride of Penhurst Carnation, Papaver nudicaule varieties, Delphiniums, Erigeron speciosus superbum, Eryngiums, and other plants made up a most interesting group.

## CERTIFICATED PLANTS.

*Tuberosus Begonia Prince of Orange* (H. Cannell & Sons).—A brilliant scarlet single variety, petals broad and rounded. Very handsome.

*Tuberosus Begonia Mrs. Lewis Castle* (H. Cannell & Sons).—A handsome double variety, flowers of great size and good form, of a soft salmon tint; the petals broad and symmetrically arranged.

*Tuberosus Begonias* (J. Laing & Co.).—*Alba magna*, pure white, double, very fine form. *Jupiter*, brilliant scarlet, double, very handsome. *Snowball*, pure white, full, neat. *Jubilee*, rosy crimson, double, extremely full and distinct. *Perfection*, scarlet, double, capital shape, handsome flower. *Adonis*, rich salmon, double, undulated petals, very pretty. *Lustre*, scarlet, double, brilliant colour.

*Iris Kämpferi Eclipse* (W. Gordon).—A pretty variety, dark crimson veined with white, yellow at the base.

*Iris Kämpferi Exquisite* (W. Gordon).—Flowers of medium size, lilac blue, yellow centre.

*Iris Kämpferi Acquisition* (J. Veitch & Sons).—A beautiful delicately coloured variety, flowers large, white, veined with crimson purple, stigmas purple, yellow central blotches.

*Iris Kämpferi Unique* (J. Veitch & Sons).—A medium sized flower, veined purple on a light ground, yellow central blotches.

*Iris Kämpferi Criterion* (J. Veitch & Sons).—A grand variety, flowers large, inner and outer divisions broad, rounded, nearly equal in size, richly veined with violet crimson, yellow central blotches.

*Berberis aristata integripetala* (J. Veitch & Sons).—An ornamental shrub with ovate green leaves edged with red, and long racemes of pale yellow flowers on red peduncles.

*Scolopendrium vulgare*, var. *Vallaisi* (J. Veitch & Sons).—A distinct variety, the apices of the fronds much cut and tufted.

*Carnation Amber* (C. Turner).—A bright clear yellow variety, flowers neat in form and very freely produced.

*Carnation Souvenir de la Malmaison*, pink variety (C. Turner).—Exactly the same as the well-known Souvenir de la Malmaison, except the flowers are deeply tinged with pink.

*Sweet Peas* (H. Eckford).—*Mauve Queer*, pale mauve, delicate, large flower. *Splendour*, deep rose, very rich and handsome. *Primrose*, pale buff yellow.

*Laelia Batemanniana* (Baron Schroeder, The Dell, Egham).—This interesting plant was shown with five flowers, 3 inches in diameter, sepals and petals rosy crimson, suggestive of *Impatiens Sultani*; lid small, white in the centre; wings and central lobe crimson. This Orchid is a hybrid between *Cattleya intermedia* and *Sophranitis grandiflora*, and was fully described in this Journal, page 127, vol. 13, August 12th, 1886.

is an irregular edifice, consisting of three chambers of the most elaborate execution, leading by passages into each other. The walls and vaulting of the passages and chambers are inlaid in various devices with minute pieces of spar, minerals, and shells; the lower parts united with wonderful skill. The upper chamber has a dome ceiling, from which artificial stalactites formed of satin spar of a large size are suspended with great art and elegance." It is unquestionably a wonderful piece of work, and Sir William Drake kindly permits visitors to inspect it on application to the gardener, Mr. J. Gubbins.

But to the Show. Though of very great excellence in every department it can only be briefly reported. One marquee was entirely filled with charming groups. In the large group class, 14 feet by 7 feet, the first prize was won by Mr. J. Reeves, gardener to W. Hewett, Esq., Oatlands Park, with choice healthy plants most tastefully arranged, brightness and grace being combined with good quality. Mr. J. Gubbins was a very close second with an extremely cheerful arrangement, and Mr. Reed, gardener to E. Pettit, Esq., third with a group that would have been first at not a few shows we have visited. In the smaller group class the prize given by the President, G. F. Wilson, Esq., F.R.S., was won by Mr. Millican, gardener to H. Cobbett, Esq., Walton, with a charming arrangement, in which several plants of *Campanula persicifolia* played an important part. Mr. G. Carpenter, gardener to C. J. Abbott, Esq., followed very closely indeed with a bright display; Mr. C. Gardner, gardener to R. A. Turner, Esq., well winning the remaining prize. Specimen stove and greenhouse plants, including *Ferus*

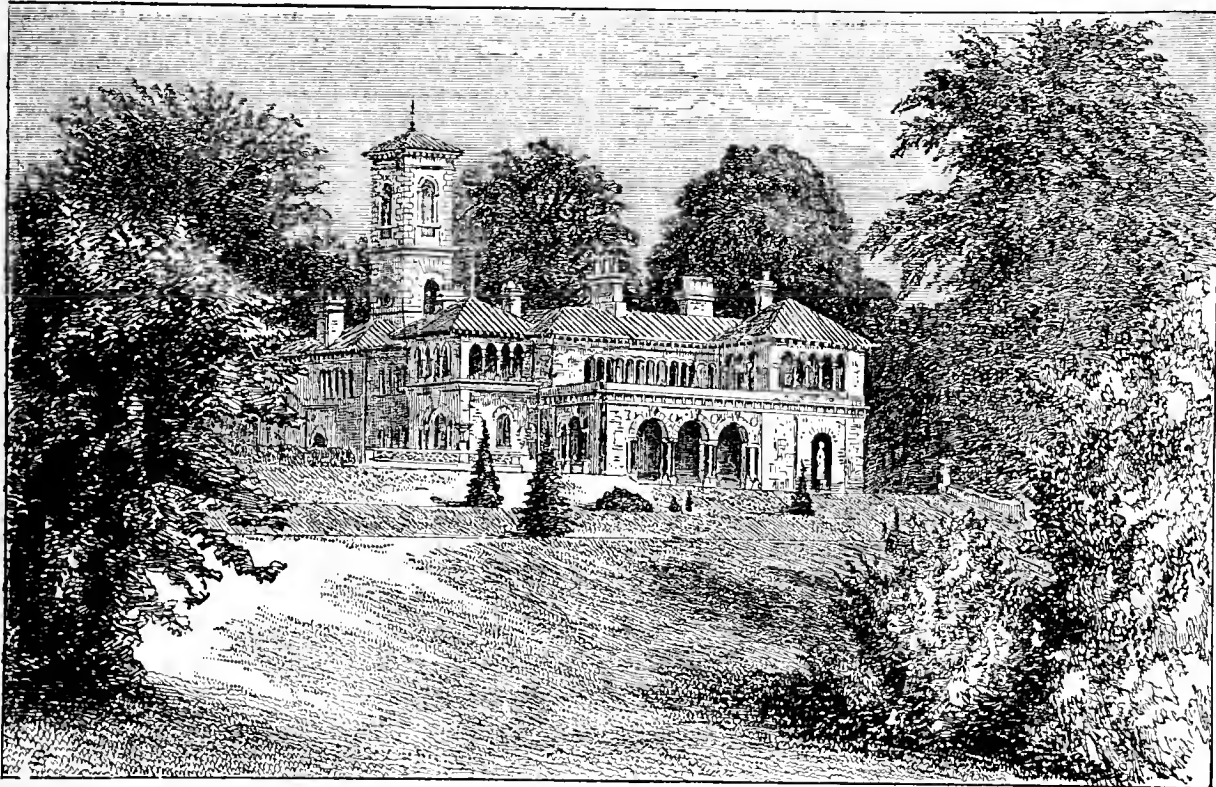

Fig. 4.—OATLANDS LODGE.

*Epidendrum Parkinsonianum* (H. M. Pollett, Esq.).—A species with long fleshy leaves and large flowers, the lip three-lobed, white, the sepals and petals narrow and yellowish.

*Odontoglossum Vuytstekianum maculatum* (Sir Trevor Lawrence, Bart., M.P.).—An interesting variety, sepals and petals pale yellow, white centre, spotted brown, lip pale with a few central brown spots.

#### THE CHERTSEY AND DISTRICT HORTICULTURAL SOCIETY.

As has been intimated in previous years, the exhibitions of this Society are moveable, and are held in the grounds of gentlemen residing in Chertsey, Weybridge, or Walton—a district noted for many charming suburban residences, also for good gardening. The twenty-second annual Show was held on the 7th inst. in the grounds of Oatlands Lodge, the residence of Sir William Drake, and it would be difficult to imagine any site better suited for the purpose, the grounds being gently undulated and well wooded with splendid trees. The Secretary of the Society, Mr. T. J. Rawlings, Chertsey, in his attractive and entertaining "Handbook of West Surrey," gives an illustration of Oatlands Lodge, which he has placed at our disposal. As will be seen, it is in the Italian style of architecture—not an extensive but a handsome building situated in beautiful grounds. The great feature of these grounds is a wonderful grotto, of which it would be difficult if not impossible to find its equal elsewhere. In North's "Views of Walton and Neighbourhood" (J. North, Oatlands Park) it is stated "This magnificent structure of shell work was constructed about 1747 by the first Earl of Lincoln, who afterwards succeeded to the Dukedom of Newcastle, at a cost of above £40,000. It

Fuchsias, Gloxinias, Caladiums, and Begonias, were remarkably good. Messrs. Reed, Reeves, Plowman, Millican, Child, Thorne, and Sutton winning prizes and giving the most satisfactory evidence of their skill as cultivators.

Roses were represented by many excellent stands, Messrs. G. Jackson & Sons, J. Thorne, gardener to A. G. Flood, Esq., being placed first in their respective classes, followed by Messrs. Sparrow, Gubbins, Davis and Millican.

Black Hamburgh Grapes were splendidly staged by Mr. S. Osman, gardener to L. J. Baker, Esq., Ottershaw Park; Messrs. Gardner and Sutton taking the remaining prizes. In the white class Messrs. Gardner and Osman were first and second with superior examples of Buckland Sweetwater, Mr. Reed following with Muscats not quite ripe.

Vegetables were remarkably fine, Mr. Waite staging grand examples in one class, and Mr. Reed winning chief honours with sixteen dishes in another; Messrs. Bennett and Hopkins being also prizetakers with highly creditable collections. The entire show reflected credit on officials and exhibitors; and Mr. Gubbins must be congratulated on the flower gardening and carpet bedding that was in keeping with the terrace on which it is displayed.

#### THE EALING, ACTON, AND HANWELL HORTICULTURAL SOCIETY.

The annual Exhibition of the Society was held on the 6th inst. in the grounds of the Royal Indian Asylum, kindly placed at the disposal of the Committee by Dr. Christie. Five large tents were used for the purposes



of the Exhibition, one of them for epergnes, bouquets, baskets of flowers, and table decorations—a charming tent; another for fruit and cut flowers only; one tent for cottagers' productions, which, owing to the adverse seasons, were not up to the usual standard generally, although numerous, and to nearly 400 bunches of wild and garden flowers exhibited by children. The other tents were devoted to plants and the gardeners' vegetables, &c.

In the principal tent was a very handsome display; at the entrance a superb group of Pelargoniums, exhibited by Mr. C. Turner, Royal Nurseries, Slough, were staged by the veteran Geranium grower of the Slough Nurseries, Mr. Frost, and these plants were most deservedly admired; five of them, including Chief Secretary, and Mandarin, and a lovely fancy "Ambassadress," obtaining first class certificates. At the other end of the tent Messrs. Charles Lee & Son staged a large and beautiful group of Roses in pots, suitable for conservatory decoration, showing how easily good well-flowered plants can be grown in small pots; and handsome gold and other coloured Ivies in pots were intermixed with them. Close by this eminent firm of nurserymen had set up a large group of rare variegated and other ornamental trees and shrubs in pots, a beautiful specimen of the variegated Maidenhair Tree occupying a central position. These groups are always most interesting to our older horticulturists. In this tent Mr. Roberts of Gunnersbury Park contributed, not for competition, a very large handsome group of Palms, flowering and fine-foliaged plants, in which were some very fine Gloxinias, superbly grown Souvenir de la Malmaison Carnations, and several admirably grown specimens of Impatiens Sultani grown from seed. This admirably put up group was one of the most striking feature of the Exhibition. In the larger groups for competition, Mr. Hudson, gardener to H. J. Atkinson, Esq., Gunnersbury House, was first with a beautiful group; Mr. Chadwick, gardener to E. M. Nelson, Esq., being second with a capital group. In stove and greenhouse plants there was a great falling off, Mr. Chadwick being the chief exhibitor, and exhibits in the classes for Ferns and ornamental plants fell short. Mr. Wright, gardener to G. R. Springfield, Esq., Hanwell, deserves much praise for his four fine Fuchsias, which took the first prize, as well as for his single specimen, which not only took the first prize, but also was awarded Messrs. Wood & Sons' Jubilee medal for the best flowered plant in the Exhibition. Some good Pelargoniums and Zonals were staged. In the next tent, Messrs. Fromow & Sons, the well known nurserymen, occupied the front place with a well set up large group of plants, in which were several Orchids, and their exhibit was another feature of the Exhibition. In the smaller groups in this tent Mr. Sutton, gardener to Mrs. Wilkinson, Ealing, was placed first, four other groups also being set up.

The very heavy entry of exhibits of wild and garden flowers by the school children gave the Judges a heavy morning's work. The large fruit and flower tent was an exhibition in itself, and a most attractive one. In the competing classes for Roses in the large open classes Mr. C. Turner, Messrs. Paul & Son, and Mr. Rumsey took the honours in the order of their names. In the other classes there was a keen competition amongst the amateurs. The Rose portion was considerably augmented by very large collections of fine blooms sent by Messrs. James Veitch and Sons, and Messrs. C. Lee & Son, the latter firm also contributing a fine display of cut herbaceous blooms. The other cut flower portion of the Exhibition was well filled. There was not a large display of fruit, but Mr. Daw of Castle Bar took the first prize for a good collection. In black Grapes two medium-sized well-finished bunches of Madresfield Court was first, some excellent Black Hamburgs being placed second. The weather was fine, a large company attended, the ground was most pleasant and most suitable for a horticultural exhibition.

There is one thing which crops up at these exhibitions which should be remedied as far as possible. Exhibitors enter in various classes some time beforehand, but fail to fill many of these classes on the morning of the exhibition. At Ealing Mr. Richard Dean and his coadjutors mark out spaces for each collection entered, and a card with the classes and exhibitor's name is placed in each, so as to facilitate the work of the exhibitors and the Superintendent, and get everything in order for the Judges at an early hour. The arrangements in these respects are perfect at Ealing, and if exhibitors would only let the Secretary know on the morning preceding the Show what they cannot exhibit spaces would not be allotted, and much unnecessary work and annoyance would be spared the executive. It is simply a duty on the part of exhibitors that they should do this, and these remarks apply to the exhibitors connected with every exhibition in the kingdom.

### WIMBLEDON SHOW.

As was briefly intimated last week, the fiftieth annual Exhibition of the Wimbledon Horticultural Society, held on the 6th inst., was one of the best of the series, and decidedly an improvement on some of the shows of recent years. The park-like grounds of Woodhays, the suburban residence of Laundry Walters, Esq., were kindly placed at the disposal of the Committee, and the site was admirably adapted to the worthy object of displaying the horticultural produce of the district. It is gratifying to observe that much active interest is taken in the work of the Committee, no less than seventy special prizes being given, apart from those offered by the Society—a number not often equalled and very rarely excelled.

The marquee that was provided for cut flowers was well filled, and the boxes of Roses, stands of herbaceous flowers, great display of buttonhole bouquets, Gloxinias, collections of Grasses, and other objects,

proved highly attractive to the visitors. Roses were not large, but, as a rule, fresh, and the display on the whole was satisfactory. In the special class for twenty-four Roses there was good competition, Mr. C. Gibson, gardener to J. Wormald, Esq., Morden Park, securing the premier place with fresh good blooms, admirably arranged. W. F. Faulkner, Esq.; Fairholm, Wimbledon, was a rather close second; and Mr. G. Walsh, gardener to S. Wilson, Esq., the Old Rectory, Wimbledon, third.

Several good stands of twelve blooms were staged, the Society's prizes being won by Mr. H. Alderman, gardener to G. Hatfield, Esq., Morden Hall; Mr. F. Ware, gardener to F. Fox, Esq., Hill House; and Mr. Smith, gardener to J. MacFarlan, Esq., in the order named, the first prize stand especially containing excellent blooms. Sir F. Saunders' prizes for the same number of blooms were awarded to Mr. C. Gibson, W. Northover, Esq., and Mr. Smith respectively, the second running the first prize blooms closely, Mr. Northover being evidently a good grower and exhibitor. Dr. Hughes' prizes for three blooms in four varieties were won by T. Conway, Esq., and Mr. E. Gibson, the former staging fresh and good Teas, Anna Ollivier, Madame Falcot, Caroline Kuster, and Innocente Pirola. Mr. W. B. Faulkner gave prizes for six blooms of any variety, and won the first himself with Merveille de Lyon, Mr. Northover following very closely indeed with Marquise de Castellane. Mr. W. S. Thomson, nurseryman, staged very fine Roses not for competition, and contributed materially to the general display. Hardy flowers were well represented, Messrs. Hunt, Southean, and Caswell securing the prizes, Mr. Thomson staging an excellent non-competitive collection.

The plant tent was well furnished, several groups arranged round the sides contributing to the effect. In the 100 square feet arrangements, Mr. D. Bridger, gardener to Laundry Walters, Esq., secured the first position with a free, fresh, and bright assortment of healthy plants. Mr. J. Law, gardener to R. Deau, Esq., was a close second, his arrangement being more formal, and Mr. Bentley, gardener to Sir T. Gabriel, Bart., Edgcombe Hall, third. In the smaller group classes the prizes were awarded to Messrs. Ware, Smith, Carter, and Methven. In the specimen plant classes, Messrs. Methven, Bentley, H. Alderman, Law, and Newell, were the prizetakers, the whole staging good examples of culture. Ferns, Fuchsias, Achimenes, Coleuses, Caladiums, Pelargoniums, and Begonias were well represented, the chief prizewinners being Messrs. Bentley, Law, Colc, Newell, Thornton, Methven, and Smith. Messrs. J. Laing & Co. contributed very fine Begonias, and Messrs. Jas. Veitch & Sons an excellent group of Roses in pots.

Fruit was well represented. In the class for black Grapes the first prize was well won by Mr. J. Fenn, gardener to T. Single, Esq., with very fine Black Hamburgs, and he was first also in the white class with good Muscats, the other prizes falling to Messrs. Caswell, Methven, and Bentley. Mr. H. Alderman staged the best Peaches and Strawberries, Mr. Methven the best Melon, Hero of Lockinge.

Vegetables were wonderfully fine, especially those with which Mr. C. Waite, gardener to Hon. W. P. Talbot, won the Society's and Messrs. Sutton & Sons' prizes, Messrs. H. Alderman, W. Harris, and R. Real also securing prizes for excellent produce. Mr. A. Newell won the chief prize for salads, also for Cucumbers, staging a handsome pair named Jubilee.

Two excellent Secretaries, Dr. George Walker and Mr. J. Lyne, represent a combination of science and practice that cannot fail to be of great advantage to the Society.

### ROSE SHOWS.

CRYSTAL PALACE, SYDENHAM.—JULY 2ND.

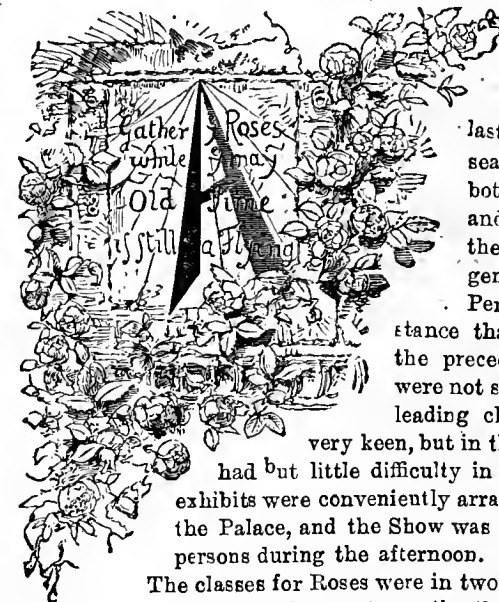

**SATISFACTORY** Show was held at "the Palace" on Saturday last, though the effects of the season were clearly evident both in the number of exhibits and in the quality of many of the Roses shown. Taking them generally, however, the Hybrid Perpetuals were of better substance than at South Kensington on the preceding Tuesday, but the Teas were not so numerous. In some of the leading classes the competition was very keen, but in the smaller classes the Judges had but little difficulty in making their awards. The exhibits were conveniently arranged on tables in the nave of the Palace, and the Show was visited by a large number of persons during the afternoon.

The classes for Roses were in two sections, Classes 1 to 22 open classes, 24 to 28 for amateurs, the three concluding classes being for Picotees, Carnations, and Pinks.

The principal open class was for seventy-two distinct, single trusses. Mr. B. R. Cant, Colchester, was awarded first honours in a class of four exhibitors with capital blooms, more even and of better substance than at South Kensington recently. The varieties were Mrs. Baker, Madame Hip-



polyte Jamain, Reynolds Hole, Madame de Watteville, Charles Lefebvre, Gloire de Vitry, Dupuy Jamain, Marguerite de St. Amand, Etoile de Lyon, Mrs. George Paul, Madame Bravy, Duchesse de Caylus, Queen of Queens, Sultan of Zanzibar, Hon. Miss Edith Giffard, Prince Arthur, Prince Camille de Rohan, Jean Ducher, Mary Bennett, Duchess of Connaught, Beauty of Waltham, Marie Van Houtte, Madame Cusin, Alfred Colomb, Madame Charles Wood, Emily Laxton, Dr. Sewell, Merveille de Lyon, Marie Baumann, Comtesse de Serenye, Countess of Oxford, Madame Gabriel Luizet, Lady Mary Fitzwilliam, Général Jacqueminot, Louis Peyronny, Ferdinand de Lesseps, John Hopper, Madame Caroline Kuster, Black Prince, Lord Frederick Cavendish, Madame Margottin, Harrison Weir, Comtesse de Nadaillac, Star of Waltham, La Boule d'Or, La Duchesse de Morny, Madame Lacharme, A. K. Williams, Duchesse de Vallombrosa, Etienne Levet, Innocente Pirola, Madame Prosper Laugier, Madame Eugene Verdier, Ulrich Brunner, Her Majesty, Madame Marie Cointet, Madame Alfred Dumesnil, Maréchal Niel, Marie Rady, François Michelon, Xavier Olibo, Catherine Mermet, Le Havre, Madame Hippolyte Jamain, Mons. Noman, Eugène Fürst, Baroness Rothschild, Abel Carrière, Souvenir d'Elise, Duke of Wellington, and Duke of Teck. Mr. F. Cant, Colchester, was second with a bright, fresh collection; Messrs. Paul & Son being third with neat blooms.

In the next class, which was for forty-eight varieties, distinct, three trusses of each, Messrs. Paul & Son secured first honours with the following—Marie Rady, Marquis de Castellane, Merveille de Lyon, Abel Carrière, Comtesse d'Oxford, Maréchal Niel, Queen of Queens, Alfred Colomb, Etienne Levet, La France, Charles Lefebvre, Her Majesty, Marshal P. Wilder, Dr. Andry, Souvenir d'Elise Vardon, Edouard André, Madame Prosper Laugier, Catherine Mermet, Innocente Pirola, Prince Arthur, Xavier Olibo, Etoile de Lyon, Lady Mary Fitzwilliam, Madame Norman Neruda, Grandeur of Cheshunt, Victor Verdier, Madame Gabriel Luizet, Maurice Bernardin, Beauty of Waltham, Henrich Schultheis, Jean Ducher, Fisher Holmes, Horace Vernet, Marguerite de St. Amand, Niphotos, Beauty of Waltham, Reynolds Hole, Pride of Waltham, Boieldieu, Duchesse de Caylus, Alphonse Soupert, Sénateur Vaisse, Madame de Watteville, La Duchesse de Morny, Marie Baumann, Souvenir de la Malmaison, Comtesse F. de Bellanger, Marie Louise Pernet. Mr. B. R. Cant was a close second, these two being the only competitors.

For twenty-four varieties, three trusses of each, Mr. C. Turner, Slough, was placed first amongst nine exhibitors with fresh handsome blooms of a good selection of varieties; Messrs. Keynes, Williams & Co., Salisbury, were second, and Messrs. W. Balchin & Son, Hassocks Gate, Sussex, third.

Class 4 was provided for twenty-four varieties, distinct, single trusses, and the competition was remarkably keen, no less than sixteen stands being entered, and though the quality was not high numbers of fresh bright blooms were shown. Messrs. Keynes, Williams & Co., Salisbury, were first with Ulrich Brunner, Merveille de Lyon, A. K. Williams, Duchesse de Vallombrosa, Xavier Olibo, Baroness Rothschild, Reynolds Hole, Madame Eugene Verdier, Niphotos, Star of Waltham, Catherine Mermet, Mdlle. Marie Rady, Maréchal Niel, Penelope Mayo, Madame Gabriel Luizet, Alfred Colomb, François Michelon, Madame Sertot, Msdame Charles Wood, Peach Blossom, Rosieriste Jacobs, Souvenir d'Elise, Horace Vernet, and Her Majesty. Mr. G. W. Piper, Uckfield, was second, and Mr. G. House, Peterborough, third.

Seven exhibitors staged collections of eighteen Tea and Noisette Roses. Mr. B. R. Cant was adjudged the first prize for capital blooms of Souvenir d'un Ami, Innocente Pirola, Devoniansis, La Boule d'Or, Jean Ducher, Madame Cusin (grand b'ooms), Niphotos, Comtesse de Nadaillac, Maréchal Niel, Madame Bravy, Madame de Watteville, Catherine Mermet, Etoile de Lyon, Hon. Miss E. Giffard, Souvenir d'Elise, Rubens, Madame Caroline Kuster, and Madame H. Jamain. Mr. F. Cant followed in the second and third places respectively with fresh blooms.

The open classes for collections of Roses in particular colours, and for specified varieties or others similar to them in colour, formed an interesting feature of the exhibition, most of the blooms being of good quality. For a collection of yellow Roses, three trusses of each, Mr. B. R. Cant took the lead with Maréchal Niel, Jean Ducher, Marie Van Houtte, Madame Caroline Kuster, Etoile de Lyon, Madame Margottin, La Boule d'Or, and Comtesse de Nadaillac, excellent. Mr. Prince followed with smaller blooms, and Mr. G. Mount was third.

Mr. B. R. Cant led with white Roses, Merveille de Lyon, Innocente Pirola, Devoniansis, Niphotos, Madame Lacharme, and Madame Bravy being the best represent d. Mr. G. Frince was second, having Alba Rosea, Merveille de Lyon, and Innocente Pirola very fine. Messrs. J. Burrell and Co., Cambridge, were third. Mr. F. Cant had the best collection of pink Roses, comprising Mons. Noman, Baroness Rothschild, Souvenir d'un Ami, Madame de Watteville, Pride of Waltham, Her Majesty, Catherine Mermet, Mons. Cointet, Madame G. Luizet, Marie Finger, and La France. Mr. B. R. Cant and Messrs. W. Balchin & Sons were the other prizetakers in the class in the order named. With crimson Roses, Messrs. W. Balchin and Sons were the chief winners, staging good blooms of A. K. Williams, Rosieriste Jacobs, Alfred Colomb, Duke of Marlborough, Earl of Pembroke, Mons. E. Y. Teas, Charles Lefebvre, Comte Raimbaud, and Fisher Holmes, Messrs. Paul & Son and B. R. Cant following closely. Messrs. W. Balchin and Sons were also first with velvety crimson Roses, having satisfactory examples of Fisher Holmes, Eugène Fürst, Abel Carrière, Reynolds Hole, Victor Hugo, and Louis Van Houtte. Second, Mr. B. R. Cant; third, Messrs. Paul & Son.

Maréchal Niel was shown by Mr. B. R. Cant, who was first with moderately good blooms, Mr. G. W. Piper and Mr. F. Cant, who were second and third. For eighteen trusses of any Tea or Noisette Rose Mr. B. R. Cant was first with Innocente Pirola, Mr. F. Cant second with La Boule d'Or, and Mr. Piper third with Jean Ducher. In the Marie Baumann class Mr. B. R. Cant led with handsome blooms of Ulrich Brunner, Mr. G. Pricue and Messrs. W. Balchin & Son being second and third with Marie Baumann. Prince Camille de Rohan was not shown in the class devoted to it, but the prizes went first to Messrs. J. Cranston & Co. for Abel Carrière, second to Mr. B. R. Cant for Reynolds Hole, and third to Mr. G. Mount for Abel Carrière. In the François Michelon class Messrs. Paul & Son were first with Ulrich Brunner in capital condition, Mr. B. R. Cant was second with François Michelon, and Messrs. Balchin & Son third for Boieldieu. The Lady Mary

Fitzwilliam class was a good one, nine competitors entering, and all the prizetakers showed Her Majesty, Mr. H. Bennett, Shepperton, leading with good blooms. Mr. B. R. Cant was second, and Mr. G. Prince third. Five fairly good stands of A. K. Williams were exhibited, Mr. B. R. Cant winning first honours, followed by Messrs. Low & Co., Clapton, and Messrs. Paul and Son. The best blooms of William Allen Richardson came from Messrs. J. Cranston & Co., Hereford; Mr. John House and Messrs. Bunyard & Co. also exhibiting well for the second and third places. Niphotos was shown by Messrs. G. W. Piper, Paul & Son, and Keynes, Williams & Co., Rosa polyantha varieties being contributed by Messrs. C. Turner, G. Prince, and Paul and Son, who were awarded the prizes in that order.

The principal class devoted to amateurs was that for forty-eight varieties, distinct, single trusses, in which Mr. W. J. Grant, Hope End Farm, Ledbury, gained first honours with fresh, bright blooms of Annie Wood, Baroness Rothschild, Alfred Colomb, Madame Sophie Fropot, Ulrich Brunner, La France, Comtesse d'Oxford, Mdlle. Eugénie Verdier; an unnamed Rose much like Caroline Kuster, but thought to be Madame Margottin, Dupuy Jamain, Alba Rosea, Marie Baumann, Caroline Kuster, Horace Vernet, A. K. Williams, Rubens, Mrs. Jowitt, Catherine Mermet, La Rosière, Innocente Pirola, Louis Van Houtte, Madame Lambard, Fisher Holmes, Madame Hippolyte Jamain, Etienne Levet, Merveille de Lyon, Star of Waltham, Madame Eugénie Verdier, Mrs. Baker, Marguerite de St. Amand, Marie Verdier, Etoile de Lyon, Anna Ollivier, Général Jacqueminot, Duchesse de Morny, Dr. Andry, Madame Gabriel Luizet, Duke of Edinburgh, Pride of Waltham, Abel Carrière, Le Havre, Captain Christy, Marie Rady, Devoniansis, Madame Crapelet, Souvenir d'un Ami, Prince Arthur, and Mrs. Rodoconache. The Rev. J. H. Pemberton, Havering, Essex, was second, having handsome blooms of Marie Rady, Xavier Olibo, Ulrich Brunner, Horace Vernet, and A. K. Williams. S. P. Budd, Esq., 8, Tay Street, Bath (gardener, Mr. G. Campbell), was awarded the third prize for a fresh collection of small blooms. There were five exhibitors.

Mr. E. B. Lindsell Bearton, Hitchin, took the lead with twenty-four varieties, single trusses, showing flowers remarkable for their fresh bright colours rather than for their size. The varieties were Ulrich Brunner, Abel Carrière, Marie Cointet, Madame G. Luizet, Horace Vernet, Lord Macaulay, Marie Rady, Duchesse de Vallombrosa, Dr. Sewell, Charles Lefebvre, Louis Van Houtte, Monsieur Noman, Beauty of Waltham, Marie Finger, Prince Arthur, Marquis de Castellane, A. K. Williams, Merveille de Lyon, Dr. Andry, Duke of Wellington, Alfred Colomb, Duchesse de Morny, La France, and François Michelon. G. Christy, Esq., Backharst Lodge, Westerham, was second, and R. West, Esq., Reigate, third.

There were seven entries with twenty-four triplets, Mr. E. B. Lindsell being again first with a grand collection, comprising Baroness Rothschild, Fisher Holmes, La France, Madame G. Luizet, Marie Baumann, Etoile de Lyon, Merveille de Lyon, Dr. Sewell (very fine), Caroline Kuster, Mons. Noman, Duke of Wellington, Marie Cointet, Comtesse de Nadaillac, Marie Finger, Etoile de Lyon, Ulrich Brunner, Niphotos, Innocente Pirola, Souvenir d'Elise Vardon, Abel Carrière, Catherine Mermet, Louis Van Houtte, Maréchal Niel, and Comte Raimbaud. Mr. James Brown, gardener to Mrs. Waterlow, Great Doods, Reigate, and the Rev. J. H. Pemberton secured the other prizes. The best collection of twelve varieties (H. P.) was shown by Mr. H. Shoemith, Saltwood Rectory Gardens, Hythe, Kent; T. F. B. Atkins, Esq., and Messrs. Ashurst & Tucker following in that order.

The Rev. E. G. King, Madingley Vicarage, Cambridge, was first with substantial blooms of twelve Tea and Noisette Roses, but badly staged. The best were Souvenir de Paul Neyron, Souvenir d'Elise Vardon, Jean Ducher, Souvenir d'un Ami, Madame Bravy, Caroline Kuster, Madame Cusin, Comtesse de Nadaillac. E. M. Bethune, Esq., Denne Park, Horsham (gardener, Mr. Harris), was second with fresh neat blooms. The Rev. Hugh Berners, Ipswich, and the Rev. J. H. Pemberton were placed equal thirds. There were seven entries.

The prizes for Picotees, Carnations, and Pinks were awarded to Mr. J. Douglas, Ilford; Mr. C. Turner, Slough; Mr. F. Hooper, Bath; and Mr. H. Catley, Bath. The miscellaneous exhibits, for which special prizes were awarded, were as follows:—A large collection of hardy flowers from Mr. T. S. Ware, Messrs. Barr & Son, and Hooper & Co.; Messrs. H. Cannell and Sons showing a handsome collection of double Tuberosa Bezoniæ; and Mr. J. House, Peterborough, had plants of a Strawberry named Victoria, said to be a cross between President and British Queen, very prolific, one plant having 125 fruits, bright red, and of conical form. Certificates were awarded to Mr. C. Turner for Carnation Amber; to Mr. Douglas for Picotee Agnes Chambers; and to Mr. T. S. Ware for Gaillardia maxima.

#### BATH.—JULY 7TH.

ALTHOUGH unfortunately clashing with several other fixtures, and also taking into consideration how very injurious the long spell of excessively hot and dry weather has been to the Roses, this popular Exhibition must yet be considered a decided success. There were certainly fewer exhibitors, notably in the open classes, than usual, many entries being withdrawn at the last moment, but thanks to the efforts of several competitors who put up their surplus blooms no appreciable falling off, as far as quantity was concerned, was noticeable. As will be seen by the prize lists, many well-known exhibitors from far and near were represented, though only in but few instances were their exhibits up to their usual excellence, more especially as regards the size of the blooms. The Show was held in the Sydney Gardens and was well attended.

In the nurserymen's class for seventy-two distinct varieties, single trusses, Messrs. Harkness & Sons, Bedale, were easily first, their blooms generally being larger than those staged by other competitors, and were fresh and bright in colour. The most noteworthy blooms were of Alba rosea, Princess Beatrice, Mons. Alfred Dumesnil, Madame Montet, Prince Arthur, Duke of Teck, Alfred Colomb, François Michelon, Countess of Oxford, Louis Van Houtte, Comtesse de Nadaillac, Violet Bonyer, Duke of Edinburgh, Général Jacqueminot, Auguste Rigotard, Captain Christy, Mons. Noman, Constantin Petriakoff, Lady Mary Fitzwilliam, E. Y. Teas, Thérèse Levet, Marie Baumann, Etienne Levet (very fine), Sultan of Zanzibar, Duke of Wellington, Dupuy Jamain, and La Duchesse de Morny. Messrs. Paul & Son, Cheshunt, were second, among theirs being good blooms of Horace Vernet, Madame de Watteville, Camille Bernardin, Louis Van Houtte, Le Havre, Jean Ducher, and Sultan of Zanzibar. Messrs. G. Cooling & Sons, Bath, were a creditable

third, such sorts as Her Majesty, Duke of Albany, Duc de Rohan, and Maréchal Niel being especially good in their stands. Messrs. Paul & Son were first for thirty-two distinct varieties, triplets, and Messrs. G. Cooling and Son second, each having a good selection. There was stronger competition with eighteen triplets, distinct, and here Messrs. Curtis, Sanford, and Co., Torjay, were placed first, although many of their blooms were too far advanced. They had good Niphotos, Dr. Andry, Maréchal Niel, Marie Baumann, Mrs. C. Wood, Merveille de Lyon, Charles Darwin, Charles Lefebvre, and Baroness de Rothschild. The second prize was well won by Messrs. Keynes, Williams & Co., Salisbury, who had a much fresher lot, among which the best were Marie Baumann, Ulrich Brunner, Reynolds Hole, Niphotos, A. K. Williams, Star of Waltham, Catherine Mermet, and Marie Rady. Messrs. John Jefferies & Son, Oxford, were third. The last named were well first for thirty-six varieties distinct, single, among which were good Marie Baumann, Etienne Levet, Duke of Teck, Dr. Andry, M. E. Y. Teas, Louis Van Houtte, and Lady Mary Fitzwilliam; Messrs. Curtis, Sanford and Co. were second, and Mr. George Prince, Oxford, third. There were several good stands of eighteen Teas or Noisettes in competition, Mr. Prince, however, being well first with, among others, fresh and beautiful blooms of Reine de Portugal, Comtesse de Nadaillac, Maréchal Niel (awarded the medal offered for best Tea in the Show), Catherine Mermet, Souvenir d'un Ami, Boule d'Or, Madame Hippolyte Jamain, Madame de Watteville, Alba rosea, Hon. Edith Giffard, Princess of Wales, Madame C. Kuster, and The Bride. Messrs. Paul & Son were second, Madame de Watteville, Jean Ducher, and Innocente Pirola being extra good; and Mr. J. Mattock, Cirencester, third.

Among the amateurs' exhibits were some of the freshest, if not quite the largest, blooms in the Show. Particularly good were those shown by Mr. T. B. Hall, Birkenhead, in the class for thirty-six distinct varieties, single trusses, and which were awarded the first prize. The best of these were Julius Finger, Marquise de Castellane, Louis Van Houtte, Duchess of Bedford, Marie Rady, Madame Cusin, La Havre, Rosieriste Jacobs, Sir Garnet Wolseley, Prince Arthur, Merveille de Lyon, Général Jacqueminot, Ulrich Brunner, Hon. Edith Giffard, Captain Christy, Dr. André, and Louis Van Houtte. Mr. S. P. Budd, Bath, was a good second, his best being Xavier Olibo, Duchess of Bedford, M. Benoit Comte, Dupuy Jamain, Charles Darwin, and Lou's Van Houtte. Mr. W. J. Grant, Hereford, followed, his stands including François Michelon, Duke of Edinburgh, Star of Waltham, John Bright, A. Colomb, and Countess of Oxford in good condition, the last named being awarded the silver medal of the National Rose Society offered for the best Hybrid Perpetual in the Show, but which in our estimation should have gone to the Etienne Levet in Messrs. Harkness' exhibit previously noted. Mr. T. B. Hall was again first for eighteen triplets, distinct, Mr. W. J. Grant being second, and Mr. S. P. Budd third, all having many good blooms of well-known sorts. The best twelve Teas or Noisettes, distinct, were staged by Mr. W. J. Grant, who had Madame Hippolyte Jamain, Souvenir d'Elise Vardon, La Boule d'Or, Madame Bavy, Carline Kuster, and Jean Ducher, fresh and good. Mr. S. P. Budd second. In the next three classes amateurs exhibiting in the three preceding classes were debarred from entering. Mr. A. Evans, Marston, was well first for twenty-four distinct varieties, single trusses, Mr. W. Narrowway, Oxford, being second, and Mr. T. Hobbs, Bristol, third, all having creditable stands. With twelve triplets Mr. Narrowway was first, his best being Duchess of Bedford, Comtesse de Nadaillac, and Marie Rady. Mr. T. Grubb, Warminster, was a good second, and Mr. A. Evans third; an extra prize being awarded to Mr. W. Chapman, Warminster. Mr. Narrowway was first for six Teas or Noisettes, Mr. J. Smith, Warminster, second, and Mr. T. Hobbs third.

Several classes were provided for local amateurs, several of whom showed fairly well. The National Society's gold medal and a money prize offered for twenty-four single trusses, distinct, was easily won by Mr. S. P. Budd, who had good examples of Comtesse de Paris, Duchess of Bedford, Benoit Comte, Horace Vernet, Camille Bernardin, Star of Waltham, Ulrich Brunner, Xavier Olibo, Comtesse de Serenyi, Baroness de Rothschild, M. Noman, and Bois dieu; Mr. F. J. Walker was second, and Mr. A. Hodges third. Other successful local exhibitors were Mr. E. B. Cater, Mr. H. James, the Rev. G. E. Gardiner, Mr. T. W. Dunn, Mr. F. J. Walker, and Mr. T. Jolly.

There was a great falling-off in the competition for various prizes open to all exhibitors. In the class for twelve single trusses of any Rose Messrs. Keynes, Williams & Co. were first for the richly coloured Reynolds Hole in fairly good condition, Messrs. Curtis, Sanford & Co. being second for a good stand of Merveille de Lyon, and Mr. Hobbs third with Baroness de Rothschild. Mr. J. Smith was the only exhibitor of twelve blooms of any yellow Rose, and was awarded the first prize for a fine stand of Maréchal Niel. For any crimson variety Messrs. Curtis, Sanford & Co. were first with Marie Rady, fresh and good, Messrs. Keynes, Williams & Co. being second with A. K. Williams, and Mr. S. P. Budd third with Ulrich Brunner. The prizewinners for La France were Messrs. Curtis, Sanford & Co., and Mr. S. P. Budd. In the class for six trusses of any new Rose, 1885 and 6, Messrs. Paul & Son were first with Her Majesty, of good size and quite fresh, Messrs. Cooling & Sons being a close second with the same variety, and Mr. G. Prince third with The Bride. Messrs. Cooling & Son were first for twelve bunches of Teas suitable for buttonholes, another exhibitor being disqualified owing to having included Noisette W. A. Richardson. Messrs. Cooling & Son were well first with a lovely basket of Roses on a stand, Mr. Mattock being second, and Mr. A. A. Walters third. For twelve bouquets of Roses Mr. Mattock was first and Messrs. Cooling & Son second, both having beautiful exhibits. Mr. W. Narrowway was first for six bouquets, Mr. S. Brown second, and Mr. W. Chapman third.

#### PORTSMOUTH.—JULY 5TH.

For the last four years summer shows have been held in this town in connection with a fancy bazaar, without offering prizes in any form, the proceeds being devoted to local charities, and right well have they been carried out, judging from the amount handed over to these institutions. In no town do we know where horticultural exhibitions are more largely attended by the working classes, owing, no doubt, in a measure to the fact that popular prices are charged for admission, high charges not being tolerated; as low a rate of one penny each is the admission on the evening of the last day. This year a new departure was taken with a view to improve the quality of the exhibition—viz., that of offering substantial

prizes for a representative show in all branches of horticulture, which had the effect of inducing such giants as Mr. J. Cypher of Cheltenham to enter the lists. Roses, too, were a strong feature of the Show, but fruit and vegetables were thinly shown. The arrangements were, as they always are at Portsmouth, under the direction of the courteous Hon. Secretary, Mr. F. Power, of the best class, the tents being arranged near the band stand in the Victoria Park, which is located quite in the centre of the town, easily accessible both by train and tram. The floral arrangements in the Park, in spite of such a continual spell of dry weather, reflected great credit upon Mr. Hatch, the Superintendent.

For eight stove and greenhouse plants, distinct varieties, not less than four in bloom, the substantial sums of £10, £7, and £4 were offered as prizes. Mr. Cypher easily beat his two opponents, staging *Lantana borbonica*, *Dasyliion acrotrichum*, *Erica Parmenteriana*, *E. tricolor elegans*, *Ixoras Wiliamsi* and *regina*, all freely flowered and fresh. Mr. C. Penford, gardener to Sir F. Fitz-Wygram, Leigh Park, Havant, was second; *Cycas circinalis* was represented by a capital plant, as was also *Cycas revoluta*; a freely flowered specimen, globular in shape, of *Polygala Dalmaisiana* was effective. Mr. W. Hawkins, gardener to Mrs. Bishop, Swanwick, took third honours with smaller plants. For a miscellaneous collection of plants arranged in a half circle, 10 feet by 8 feet, Mr. M. Hider, gardener to Dr. E. K. Parson, Emsworth, occupied the first place amongst five others with a bright group, composed of plants suitable for the purpose, and neatly margined with Maidenhair Ferns and *Isolepis gracilis*. Mr. F. D. Short, Castle Road, Southsea, was second, the back of whose group was much too thin, in consequence exposing the pots too freely; Mr. Penford third, while an extra prize was awarded to Mr. Hawkins. Prizes were offered for three specimen Palms, not less than 6 feet in height; these being arranged down the centre of a large marquee, had quite a noble appearance. Mr. Cypher took first honours with vigorous specimens of *Kentias Canterburyana* and *Fosteriana*; Mr. Penford second; Mr. J. Short third, all showing well. Mr. Hider and Mr. Penford staged the best Ferns in the order named, while Mr. Cypher was successful with single specimen stove or greenhouse plant in bloom, and also for specimen foliage plant, the latter an excellent specimen *Cycas revoluta*, and the former *Ixora Pilgrimi*, followed by Mr. Short with a good *Rhynchospermum* in the flowering, and by Messrs. Legge & Son in the foliage class. For single specimen Palm, Mr. Cypher had to be content with second place, Mr. Legge beating him with *Chamaerops excelsa*. *Palar-goniums*, Show and Zonal, *Petunias*, *Fuchsias*, and *Gloxinias* were staged in goodly numbers, but call for no special comment, being freely flowered although small, the principal prizetakers being Mr. Hawkins and Mr. Penford. Prizes were offered also in the various plant classes for those persons residing in Portsea Island only, which brought forth good competition.

Cut Roses were staged in considerable numbers, and were fairly good considering the season being so dry and all against even good quality. For forty-eight distinct, single trusses, Messrs. Keynes, Williams & Co., Salisbury, occupied the first position with flowers small but neat in form; Marie Baumann, Niphotos, Camille Bernardin, Souvenir d'Elise, Mdle. Marie Rady, and Pride of Reigate were the most conspicuous blooms in the stand. M. N. ville, gardener to Mr. F. W. Flight, Cornstiles, Twyford, Winchester, was second with a stand rather uneven in size, *Etoile de Lyon*, A. K. Williams, and Ulrich Brunner being some of the best. For twenty-four distinct, three trusses, the places were occupied by the same exhibitors and in the same order. Mr. Neville led the way for twelve Tea varieties, distinct, single trusses, with a box of clean good blooms—Innocente Pirola, *Etoile de Lyon*, Comtesse de Nadaillac, Anna Olivier, and Princess of Wales; Messrs. Keynes was second with smaller and coarser blooms; Messrs. Ewing, Sea View Nurseries, Havant, was third. For twelve dark Hybrid Perpetual and the same number of light Hybrid Perpetual blooms Messrs. Keynes was first in both classes.

Fruit was staged in small quantity. The best black Grapes in three bunches were from Mr. E. Smith, Rockville, and were of moderate quality. The best white Grapes, some number of bunches were from Mr. Hawkins, the variety, Foster's Seedling, requiring a little more time to finish them properly. Mr. C. H. Kingswell, gardener to Admiral Hopkins, Portsmouth, put up the best green flesh Melon, a fine fruit of Sir G. Wolseley, and for an equally good fruit of Blenheim Orange he was awarded premier prize for scarlet colour. Mr. Penford was second in both classes. This latter exhibitor staged the best dish of Nectarines, a fairly good one of Elruge.

#### REIGATE ROSE ASSOCIATION.—JULY 7TH.

DISCOUNTING the adverse atmospheric influences, the Reigate Show quite sustained its high reputation for specimens of the highest class of Rose cultivation. There were magnificent blooms distributed throughout the different classes of exhibits, but those in division A were particularly fine. Below we will give the names in detail of those in the winning box of thirty-six. Quite a feature of the Show was a new Rose, named there Margaret Haywood, grown by the genial Treasurer of the National Rose Society, and President of the Reigate Association. Unless we are much mistaken Rose growers and Rose lovers will become better acquainted with this fine flower. It has an unusual depth of petal, and its habit is quite luxuriously free without being at all loose, and its colour is quite different from any present favourite.

Mrs. Waterlow and Mrs. Haywood carried the highest honours of the Show, but Miss Baker had an excellent box of twenty-four. The Rev. A. Caeles took the gold medal with other prizes, and Mr. Mawley, the able Secretary of the National, took a silver and bronze medal and another prize. The prize list appended will afford fuller information.

OPEN CLASSES.—Class 1.—First, thirty-six varieties, distinct, Mr. T. B. Haywood. Second, Mrs. A. J. Waterlow. Class 2.—First, twenty-four varieties, distinct, Miss Baker, who exhibited a very good box for the season. Second, Mr. T. B. Haywood. Class 3.—First, twelve trebles, Mrs. A. J. Waterlow; the best Roses were Lord F. Cavendish, Abel Carrière, and Merveille de Lyon. Second, Mr. T. B. Haywood, who followed very closely with a good box. Class 4.—First, eighteen Teas, distinct, Mr. A. J. Waterlow, who showed a fair collection. Second, Mr. T. B. Haywood.

MEMBERS' PRIZES.—Class 5.—First, Rev. Allan Cheales, for a very good stand, Messrs. Tryo and West being respectively second and third. Class 6.—First, Mr. Mawley, and medal, for Jean Liabaud, Mr. Slaughter and Mr.



Cheales taking second and third prizes. Class 7.—First, Mr. Mawley; second, Mr. Cu hill; third, M. s. Freshfield. Class 8.—First, Mr. Cuthill; second, Mr. Cheales; third, Mr. Bethune. Class 9.—First, Mr. Bethune; second, Mr. Cheales; third, Mr. Horne. Class 10.—First, Mr. Bethune; second, Mr. Bernard; third, Mr. Horne. Class 11.—First, Mr. Cheales; second, Mr. Tryo; third, Mr. Slaughter.

TABLE DECORATIONS.—Class 12.—First, Miss Waterlow, for a very tastefully arranged exhibit. Second, Miss Steel. Class 13.—First, Miss Thornton; second, Miss Waterlow. Class 14.—First, Miss Steel; second, Miss Waterlow. Class 15.—First, Miss Baker; second, Miss A. Harding. Best Hybrid, Mr. Haywood (for Margaret Haywood). Best Teas, Miss Baker (for Hon. E. Giffard).

The following are the names of the Rosses exhibited in Mr. T. B. Haywood's stand. Class 1, Division A:—Ville de Lyon, La France, Anguste Rigotard, Beauty of Waltham, Mdlle. G. Luizet, Duc de Rohan, Marie Verdier, Ulrich Brunner, Margaret Haywood, Merveille de Lyon, François Michelin, Louis Van Houtte, Lord F. Cavendish, Horace Vernet, Marquise de Castellane, Baroness Rothschild, Duchess of Bedford, Dupuy Jamain, Duchesse de Vallombrosa, Countess of Oxford, Marie Rady, Camille Bernardin, Alfred Colomb, A. K. Williams, Jean Liabaud, Xavier Olibo, Duchesse de Caylus, Pride of Reigate, Eclair, Royal Standard, Le Havre, Victor Hugo, Madame Lacharme, Duke of Wellington, Charles Lefebvre, Annie Wood.

A few of the best in twelve varieties, three trusses of each, Class 3:—Xavier Olibo, three fine trusses; Marie Rady, very fine; Duc de Rohan, bright; Mrs. Laxton, very good.

#### FARNINGHAM.

THE pleasantly situated village of Farningham, so well known to most London disciples of Isaak Walton, was all alive again on Thursday, when the annual Show of the Farningham Rose and Horticultural Society was held (not Horticultural and Rose, for the queen of flowers holds her place here), with all that could enhance its success, a lovely day, bright sun (too bright for the Roses), a delicious breeze, and with its usual surroundings of umbrageous trees, and the clear shiny Darent flowing right through the Show grounds, made up a total that could not fail to satisfy the most exacting; and when to this was added an admirable show of Roses, little room was left for complaint. The weather, it is true, was broiling, and the poor Roses felt its effect, for, as the day drew on and the company thronged the tents, they could not stand being so gazed at and succumbed.

In extent the Show was not so good as in some former years, and, as a whole, I believe the flowers were not so large or of such substance as in former years, with the exception of Teas, which were very grand; indeed everywhere they have taken Rose growers by storm, and many are thinking seriously of abandoning H.P.s. for them. This would be a grand mistake, although one would never object to the increased growth of this beautiful class. Although there were other things exhibited, and table decorations were here, as they always are, a great feature, yet, as in duty and loyalty bound, I shall confine my report to the Rose show.

In the first class for thirty-six (nurserymen) the first prize was awarded to Mr. Geo. Mount of Canterbury, beating Mr. B. R. Cant and others, thus confirming the opinion I have always formed of him, that he would one day come to the front, and when we get a dripping season, such as will suit his soil, I think that he will occupy a still more prominent place. His blooms were clean and bright, consisting of Ulrich Brunner, Prince Arthur, Mrs. Jowitz, Countess of Rosebery, Fisher Holmes, Devonensis, Duke of Teck, Baroness Rothschild, Maréchal Niel, Marie Verdier, Marie Rady, Marie-Baumann, Madame Gabriel Luizet, Dr. André, Moiré, Catherine Mermet, Duke of Edinburgh, Her Majesty, a very good bloom; Alfred Colomb, Merveille de Lyon, Dr. Sewell, Madame Eugénie Verdier, Louis Van Houtte, Eugène First, Mons. E. Y. Teas, Belle Lyonnaise, La Rosière, Madame Cusin, Abel Carrière, Etoile de Lyon, Duke of Wellington, Innocente Pirola, Camille Bernardin, Marie Van Houtte, and Xavier Olibo. Mr. Cant was second. In class 2, for twelve Teas, Mr. Frank Cant, Colchester, was first with a beautiful dozen, consisting of Madame de Watteville, Souvenir d'Elise, Maréchal Niel, Madame Caroline Kuster, Madame Margottin, Catherine Mermet, Innocente Pirola, Jean Ducher, Niphotos, Madame Angèle Jacquier, La Bonle d'Or, and Madame Hippolyte Jamain. Mr. Geo. Mount was second with an excellent box consisting of Devonensis, Maréchal Niel, Jean Ducher, Innocente Pirola, Madame Hippolyte Jamain, Souvenir d'un Ami, Etoile de Lyon, Catherine Mermet, Comtesse de Nadaillac, Madame Caroline Kuster, Niphotos, Souvenir de Paul Neyron.

In class 3, for the best twenty-four (amateurs), Mr. W. H. Wakley staged a very fine box containing the following flowers:—Eugène First, Madame Gabrielle Luizet, Etienne Levet, Lord Beaconsfield, Baroness Rothschild, A. K. Williams, Princess of Wales, François Kruger, Merveille de Lyon, Camille Bernardin, Mons. Noman, Marie Rady, Maréchal Niel, Louis Van Houtte, Marie Banmann, Duke of Connaught, John Hopper, Baron de Bonstettin, Fisher Holmes, Jules Margottin, Reynolds Hole, Mabel Morrison, and Charles Lefebvre. In class 4, for the best twelve, distinct, the first prize was awarded to Mr. E. R. West of Reigate for La France, Marie Baumann, Madame Gabriel Luizet, Violette Bouyer, Alfred Colomb, François Michelin, Prince Arthur, Ulrich Brunner, Marie Finger, Reynolds Hole, Marquise de Castellane, and Duchesse de Vallombrosa. In class 5, for nine Teas, there was a sharp contest between Mr. W. H. Wakeley and the Rev. F. Burnside, the latter winning with excellent blooms of Souvenir d'Elise, Maréchal Niel, Niphotos, Madame Cusin, Catherine Mermet, Madame de Watteville, Madame Bravy, Comtesse de Nadaillac, and Innocente Pirola. In class 6, for the six best blooms of any dark Rose, the first prize was taken by Mr. W. H. Wakeley with Louis Van Houtte, and the second by Earl Stanhope with Ulrich Brunner. In class 7, for the best six blooms of any light Rose, the prize fell to Mrs. Fuller for Madame Gabriel Luizet, and the second to Dr. Ashurst for Baroness Rothschild. In class 8, for the best twelve Roses, Mrs. Fuller was again first with Camille Bernardin, Baroness Rothschild, Charles Lefebvre, Marquise de Castellane, Merveille de Lyon, Ulrich Brunner, Madame Gabriel Luizet, Prince Arthur, Abel Carrière, Marie Finger, Etienne Levet, and Reynolds Hole; this was a beautifully fresh and even box of blooms. Dr. Ashurst was a good second. In class 9, for nine blooms, Mr. A. Sinter was first with Madame Lacharme, Prince Camille de Rohan, Edouard

Morren, Alfred Colomb, Madame Gabriel Luizet, Lord Frederick Cavendish, Marquise de Castellane, Prince Arthur, and Duchesse de Caylus. In class 10, for six blooms, Dr. Tucker was first with good blooms of Countess of Rosebery, Captain Christy, Comtesse de Nadaillac, Catherine Mermet, Madame Gabriel Luizet, and Beauty of Waltham. In class 11 the first prize was taken by Dr. Tucker with Innocente Pirola, Maréchal Niel, Belle Lyonnaise, Catherine Mermet, Madame Willermoz, and Etoile de Lyon. In the Jubilee class for nine Teas, three blooms of each, there was a sharp contest between Mr. W. H. Wakley and the Rev. F. A. Burnside with two stands of excellent flowers, Mr. Wakley securing the first prize with Madame Caroline Kuster, Princess of Wales, Maréchal Niel, Marie Van Houtte, Innocente Pirola, Souvenir d'un Ami, Comtesse de Nadaillac, Madame Bravy, and Laurette. Mr. Burnside's flowers were Comtesse de Nadaillac, Hon. Edith Giffard, Jules Finger, Maréchal Niel, Madame Bravy, Catherine Mermet, Madame de Watteville, Madame Caroline Kuster, and Madame Cusin. In class 43, Jubilee class, the prize was taken by Dr. Tucker with Ulrich Brunner, Marie Rady, Madame Eugène Verdier, Maréchal Niel, Baron de Bonstettin, Camille Bernardin, Anne Laxton, Madame Marie Cointet, and Madame Annie Wool. In class 44, also a Jubilee class, the prize was taken by Dr. Ashurst with Baroness Rothschild, Abel Carrière, Madame Gabriel Luizet, Prince Camille de Rohan, Madame Sophie Fropot, and Madame Victor Verdier.

There were, as usual at Farningham, a number of very beautiful table decorations, and when such able and experienced hands as Mrs. Seale, Miss Dalton, &c., enter into competition it may be taken for granted that good taste will be the prevailing feature, and so no doubt it was; but I must not linger on these nor on the very excellent examples of vegetables sent in for competition by the cottagers who cultivate the allotments on Sir Wm. Hart Dyke's property. But I cannot end these notes without saying how much indebted the Judges and exhibitors are to the indefatigable Secretary, Mr. Hodsell, and to the thoroughly hardworking and practical Committee, who do all they can to insure success, and who must be gratified at the manner in which their efforts are appreciated.—D., Deal.

#### MAIDSTONE.

THE Maidstone Society held its Show on Friday last in the Concert Hall, a terribly trying place for Roses, and in consequence they presented a sorry appearance in the afternoon. Mr. Wakely added to his many triumphs this year by winning the Mayor's cup for twenty-four (twelve H.P. and twelve Teas). In his box was a Mons. Noman of special excellence. Mr. Warde was second, and Mr. Hollingworth third. For eighteen varieties, any kind, Mr. Hollingworth was first, showing a lovely bloom of Her Majesty. Second, Mr. Foster, with a sport from Anna Ollivier, approaching in colour that of W. A. Richardson. Third, Mr. Wardle. With twelve Teas, Messrs. Shoemith, Warie, and Wakely were the prizetakers. For eight triplets Mr. Hollingworth was first with a wonderful Edouard Morren; second, Mr. Wakely, with a very fine Eugène First. With nine, any kind, first, the Rev. H. Biron; second and third, Messrs. Ongley and Fuller. A very good class. For six Teas, first, Rev. F. Burnside, with very bright and beautiful blooms of Madame Cusin, Souvenir d'Elise Vardon, Etoile de Lyon, Madame de Watteville, all excellent; second, Rev. H. Biron, containing a fine solid specimen of The Bride, but more like Madame Bravy than its parent, Catherine Mermet; third Mr. Ongley. For six varieties, triplets, any kind, the Rev. H. Biron was first, Caroline Kuster and Marie Rady being very fine in his stand; second, Rev. Fuller, showing Marie Banmann in capital condition. With six Teas, triplets, Messrs. Wardle and Burnside were first and second; these had the finest boxes in the Show. The third had three under-sized Maréchal Niels. Six of the same kind: Ten entered in this class, and it was most difficult to compare Teas and H.P.'s. First, Mr. Warde with fine Maréchal Niels; second, Mr. Ongley with Edouard Morren; third, Mr. Shoemith, with Gabriel Luizet.

The Decoration Prize was taken by Miss Bensted; the shoulder-knot by Mrs. Birm, with a long spray of W. A. Richardson. The Judges were T. D. Power, Esq., Rev. A. an Cheales, with Mrs. Fuller added for Decorations.—A. C.

#### SUTTON.

It has been sometimes said that it is a good thing to have deserved success even if you have not obtained it. It may be so; but it is far better to have both deserved and obtained it, and this has been the case with the founders and upholders of this excellently managed Society, which not only collects £130 subscriptions, but endeavours by every means in its power to foster the growth of the Rose, and in which it has succeeded to a remarkable degree. Each year shows an improvement in the local classes, both in the flowers exhibited and in the manner in which they are staged, while the zeal displayed by those who manage the Society does not diminish. I dropped in the evening before on the Honorary Secretary as he was completing his work for the following day. There were three others with him working away as diligently as if they were paid so much a minute for their labour—to say nothing of his energetic helpmate, who was rendering most valuable service. It is by such means that success is achieved, and not by sitting down and mourning over the want of spirit displayed by one's neighbours, or like the carter sitting down and crying on Jupiter to help them.

The Show was held this year in the grounds of the Sutton Waterworks Company, a place admirably suited for it, a large open expanse of grass where the tents were pitched, and giving abundance of room for promenading, and with a number of trees for shade. The day was a brilliant one—rather too much so for the Roses—but still one in which the managers of the Show could not but rejoice as likely to bring a number of visitors. The hot weather had told here, as elsewhere, severely on the smaller growers, but I think most people were surprised at the freshness of the flowers and the general excellence of their quality. Colours were good, brilliant, and pure, the greatest injury done by the excessive heat being the diminishing the size of the flower, and to some extent their substance.

As Sutton is essentially an amateurs' Society I must take them first. In class 1, for twenty-four distinct, single trusses, Mr. E. B. Lindsell of Hitchin was first with a very grand stand of flowers, consisting of Horace Vernet, Niphotos, Xavier Olibo, Merveille de Lyon, Ulrich Brunner, Lady Mary Fitzwilliam, Louis Van Houtte, Madame Gabriel Luizet, Comtesse



de Nadaillac (a splendid bloom), Duke of Edinburgh, Etienne Levet, Earl of Pembroke, Marie Cointet, Le Havre, Innocente Pirola, A. K. Williams, Comte Raimbaud, Maréchal Niel, Charles Lefebvre, Duchesse de Vallombrosa, Marie Rady, Marquise de Castellane, and Baronne de Rothschild. In class 2, for twelve single trusses, Mr. A. Slaughter was first with François Michelin, Dr. Baillon, Marquise de Castellane, Charles Lefebvre, Madame Gabriel Luizet, Duke of Teck, La France, Marie Rady, Ulrich Brunner, Dupuy Jamain, Duchesse de Vallombrosa, and Duke of Wellington. In class 3, for eight trebles, Mr. E. B. Lindsell was again first with a magnificent box, consisting of grand blooms of Ulrich Brunner, A. K. Williams, Merveille de Lyon, Marie Rady, Abel Carrière, Maréchal Niel, Xavier Olibo, and Gabriel Luizet. In class 4, for twelve Teas or Noisettes, Mr. T. W. Girdlestone of Suuvingdale was first with a box of beautiful blooms, consisting of Catherine Mermet, Maréchal Niel, Anna Ollivier, Madame Hippolyte Jamain, Hon. Edith Giffard, Souvenir d'un Ami, Madame de Watteville, Souvenir de Paul Neyron, Madame Caroline Kuster, Bougère, Comtesse de Nadaillac, and Innocente Pirola. In class 5, for nine distinct trusses, the Rev. Alan Cheales of Brockham Vicarage was first with a very beautiful set of blooms, consisting of Madame Gabriel Luizet, A. K. Williams, Mons. E. Y. Teas, Ulrich Brunner, Dr. Hogg, Mons. Noman, Maréchal Niel, François Michelin, and Marie Baumann. In class 6, for six blooms, Mr. Cheales was again first with Merveille de Lyon, Baronne de Rothschild, A. K. Williams, Alfred Colomb, Prince Arthur, and Maréchal Niel. In class 7, the Rev. W. Wilks of Shirley, Croydon, was first with good triplets of Xavier Olibo, Marquise de Castellane, La France, and Ulrich Brunner. In class 8, for six Teas, the Rev. A. Cheales was first with Maréchal Niel, Catherine Mermet, Souvenir de Thérèse Levet, Souvenir d'Elise, &c. In class 10 (local class) the first prize was awarded for Duchesse de Vallombrosa, François Michelin, Merveille de Lyon, Star of Waltham, Marie Rady, Baronne de Rothschild, Jean Liabaud, Madame Gabriel Luizet, Comtesse de Serenye, Edouard Morren, Madame Lacharme and Général Jacquemiouot. In class 11, for nine distinct, single trusses, the first prize was awarded for Madame Georges Schwartz, Marie Rady, Madame Eugène Verdier, Marquise de Castellane, and Countess of Rosebery. In class 15, for the ladies' challenge cup, the award was made to Mr. R. W. Miller for a good box of Charles Lefebvre, Louis Van Houtte, Marie Finger, Duke of Teck, Marie Baumann, and La France.

In the class open to all England for nurserymen only there were some good stauds exhibited, Mr. B. R. Cant of Colchester being first with Marie Cointet, Ulrich Brunner, Marguerite de St. Amand, Baronne de Rothschild, François Michelin, Dr. Sewell, A. K. Williams, Madame Lacharme, Boieldieu, Duke of Wellington, Innocente Pirola, Victor Verdier, Souvenir d'Elise, Maurice Beruardu, Heinrich Schultheis, Xavier Olibo, Antoine Ducher, Marie Baumann, Her Majesty, La Rosière, Mons. Noman, Prince Arthur, Lady Mary Fitzwilliam, Mrs. Baker, Duchesse de Vallombrosa, Star of Waltham, Princess of Wales, Le Havre, Maréchal Niel, Marie Rady, Madame Charles Wood, Sultan of Zanzibar, Madame Prosper Laugier, Marquise de Castellane, and Dupuy Jamain. Messrs. Burch of Peterborough were second, and Messrs. Paul & Son third. In the class for twelve Teas Mr. B. R. Cant was first with a beautiful box of the following—Innocente Pirola, Etoile de Lyon, Madame Cusin, Maréchal Niel, Devoniensis, Catherine Mermet, Madame de Watteville, Niphotos, Hon. Edith Giffard, Comtesse de Nadaillac, Souvenir d'Elise, and La Boule d'Or. Messrs. Pope & Son were second. Messrs. Burch third. The National Rose Society's silver medal for the best H.P. in the amateurs' classes was awarded to the Rev. Alan Cheales for the best bloom of A. K. Williams I have as yet seen this year. A similar award was made to Mr. E. B. Lindsell for the best Tea or Noisette in the Show, a bloom of Comtesse de Nadaillac.

The bouquets, hanging baskets, basket of Roses, and breast sprays, which always form a feature of this Show, were as abundant and as good as usual, and there is no place where I see the difficulty that the Rose always presents for such purposes better surmounted than they are. Mrs. E. Wilkins, Miss Gutteridge, Mrs. Dart, Miss Hughes and others were the successful competitors.

The arrangements were good, and carried out effectively by the Committee and the indefatigable Secretary, and I hope that the success which has attended their efforts will be an encouragement to press on while others are standing still, and indeed in some cases retrograding.—D., Deal.

### ROSE SHOW FIXTURES.

July 14th, Alexandra Palace, Birmingham and Harleston.	July 20th, * Birkenhead.
" 15th, * Helensburgh, * Hereford.	" 21st, Carlton - in - Lindricks (Notts) and Salterhebble (Yorks).
" 16th, * New Brighton.	" 22nd, Manchester
" 18th, * Christleton.	" 23rd, * Ulverstone.
" 19th, * Leek.	" 29th and 30th, Hull.

Those exhibitions which are held by the National Rose Society, or by Societies affiliated with it, are distinguished by an asterisk.—EDWARD MAWLEY, *Rosebank, Berkhamsted, Herts.*



### KITCHEN GARDEN.

**THE WEATHER AND THE CROPS.**—We have experienced another fortnight of unusually dry weather, but there are signs of rain, and it

is much needed, as we are getting short of water not only for the kitchen garden crops, but for indoor plants as well. Our supply is drawn from a 10 acre pond, but the mountain streams which feed it have fallen so low that the supply is less than we have ever seen it, and as this state of matters is rather general the shortcomings of garden water supplies should be noted and rectified if possible before another summer comes. Our Peas are not well in until they are over or too old for use. Spinach has come to a standstill, we have some quarters of it that are absolutely useless. Lettuces are running to seed prematurely, and wherever water and time will allow they should all be drenched once or twice weekly. Onions are succeeding, but the spring-sown ones are behind what we have had in some seasons. Four years ago we lifted a number of spring-sown Onion bulbs which measured 13 inches in circumference at the middle of July, and at the same date this year our best only measure 7 inches, thus indicating the state of the season.

**CAULIFLOWERS.**—The heads are forming fast, indeed faster than we can use them, and as this is a common occurrence some of them should be cut and stored in a cool place before they are too large. Of all Cauliflowers those that are green are the worst. They are produced by being too much exposed to the sun, and they are not valued in the kitchen or for exhibition; they should, therefore, be cut before they become green or too large, and when the heads are not well protected with leaves from the first, break some of the outer ones half through and turn them down over the heads. Where caterpillars are destroying the heads pick them off with the hand, or shake a sprinkling of salt over the soil. If planting the latest Veitch's Autumn Giant has been retarded place them out as soon as possible.

**BROCCOLI.**—We had placed various kinds of Broccoli out before the weather became so dry, and they have progressed fairly well, but we have still some thousands of plants for permanent quarters, and as many growers have still to plant out the bulk of their crops no opportunity should be lost of doing so. July-planted Broccoli succeed well as a rule, but August-planted Broccoli are rather late, and planting in that month is not recommended. All Broccoli growers should include Veitch's self-protecting autumn variety, as it is excellent in November, and December.

**TURNIPS.**—Our late Swedes and some other varieties sown three weeks ago have been hardly treated by the scorching sun; many of the young plants have failed, and the crop as it stands will not suit. Immediately rain falls the blanks in the rows will be opened with a drag hoe, a little seed will be sown, and at the same time some will be sown in another quarter, as we cannot afford to be without Turnips in winter. All Turnips sown before July is out will form useful crops by October or a little later.

**PARSLEY.**—The whole of our 1886 plants have gone to seed, and most of them have been drawn up and thrown away. Our supply is now derived from seed sown in March, as it germinated freely and has produced some good rows, but these would not remain good all winter, and another sowing should be made. This may be done as soon as possible, placing it in ground free from worms and rather rich. After the soil is well saturated with rain, draw up a number of plants from the spring-sown rows, and dibble them in elsewhere. This will give them a severe check; the large leaves they now bear will droop and die, but fresh ones will push up, and these will form compact plants for late autumn use.

**SAVOYS.**—The early-planted Savoys, are making progress, and many of them will be ready before the Savoy season has well set in, and a good number should be planted to come in later. Those planted now will form heads in November and December where the stems of Potatoes have become ripe; but if the crop is yet undug dibble the Savoys in between the rows, as the lifting of the Potatoes will not interfere with the Savoys, and they may have gained considerable size before the Potatoes are taken up. This planting between the rows saves ground and time.

**VEGETABLE MARROWS.**—We are now cutting tender fruits of Pen-y-byd from plants on a south border. This variety is of good quality and very prolific, but no Vegetable Marrow will fruit freely if allowed to bear a superabundance of roots and leaves, and care should be taken that these are constantly well thinned. Many flowers open under the shade of the large leaves, and fail to form fruits. It is generally about this time that complaints are heard of Vegetable Marrows failing, or if the fruit forms it falls before gaining a useful size; and the remedy for this is to thin the shoots in good time. Never allow the plant to make much growth, and reduce it by the armpit on one day, and see that they have sufficient water at the roots. In many cases Vegetable Marrows are planted on mounds. They then require much more water than if planted on the level ground, but this fact is often forgotten by those who grow them.

**DRYING HERBS.**—The best time to cut and dry herbs is before they come into flower. Sage, Mint, and Thyme are the principal herbs we dry. The best of the shoots are cut from them, spread out on the floor of a cool shed or room for a time, and then tied together in bundles and hung up. If dried in the sun the leaves become brittle and fall off. Dried herbs are always useful in the winter time.

### FRUIT FORCING.

**STRAWBERRIES IN POTS.**—With more than a month of dry weather, a broiling sun, and not over-abundant supplies of water and means for its application, mulching in many cases being out of the question—these circumstances, with a cold spring and late summer, have been

against securing a sufficient supply of strong early runners for layering in pots for forcing. Our best supply of runners has been furnished by the young plants that were planted out last year. There is a difference of opinion as to the most serviceable plan of layering the runners—viz., whether it is best to do so in small pots, and when they are well rooted detach and shift into the fruiting pots, or layer at once into the pots the plants are to be fruited in. Both plans are good. In either case it is essential that the first runners, which give the best plantlets, should be selected, and that they be induced by attentive watering to fill the pots with roots, so that by after judicious attention they may develop into good plants and form well-developed crowns. If layered into the fruiting pots they need not be detached until they have become thoroughly established. Those layered in 3-inch pots should, so soon as they have filled the pots with roots, and before they become much matted around the sides, be detached and stood in a shady place for a few days preparatory to shifting them into the fruiting pots. These should be 5-inch for early forcing, and 6 inches for succession, whilst 7-inch may be employed for plants that may not be required for starting before February for affording late crops of larger fruit. For early forcing we find La Grosse Sucrée and Vicomtesse Hericart de Thury capital setters, swellers, and finishers; for succession, Sir Harry or Empress Eugénie, President, and Sir Joseph Paxton, good croppers, and of excellent quality; whilst for later supplies, Sir Charles Napier, Marshal MacMahon, and Auguste Nicaise are superb. British Queen, Dr. Hogg, and Cockscorb are indispensable for late supplies. The fruiting pots must be clean, have a large crock in each, about three or four of lesser size, and over those some half-inch bones—the drainage altogether about an inch or a little more. Turfy loam, rather strong, should form the staple of the compost, being laid up sufficiently long only to destroy the herbage, tearing or chopping up, adding a quart each of soot, dissolved bone, and wood ashes to every bushel of the loam, thoroughly incorporating. The compost should be moderately dry when used, for if wet it will shrink after potting, leaving the sides of the pot. Place the rougher parts of the compost at the bottom first, and ram it hard, potting firmly, and so that the base of the crown is about half an inch below the rim. Stand the pots on a hard base in an open sunny situation, with sufficient space between them to allow for the full exposure of the foliage. Water as required, and sprinkle the foliage a few days after potting. When the roots are working freely in the fresh soil, copious supplies of water will be needed, not allowing the foliage to flag. Remove all runners as they appear.

**VINES.—Mixed Houses.**—In forcing Vines early it is hardly possible to escape attacks of red spider; more especially is this the case when the Grapes are kept for any length of time upon the Vines after being ripe. On account of this liability to red spider we do not advise large houses with a motley assemblage of Vines for forcing, but houses only of such size as will admit of a supply of Grapes for the establishment for a period of not more than six to eight weeks. This admits of the foliage being cleansed with the syringe or engine, but with a house having Frontignans, Sweetwater, and Hamburgh Grapes ripe in May, Muscats in June, and late sorts in July, the dry warm air essential to the ripening of early kinds will cause red spider to increase upon the foliage of the Muscats and other late sorts before they are ripe. This is most disastrous to present and future crops of Grapes. Instead of having a mixed collection—that started in December to the new year will afford fruit from May to August—we would divide the house into two or three compartments, so that the respective kinds may have secured to them their proper treatment. In case of an attack of red spider paint the hot-water pipes with sulphur, heating them to over 160°. Be careful not to overdo this, or it will spoil the tender-skinned kinds, as Muscats, it often causing brown spots upon the skin of those and Frontignan Grapes; sulphur, therefore, applied to heated surfaces must be done with great care.

**Scalding.**—This is a source of no little anxiety, and is common to some kinds, notably Lady Downe's, and in lesser degree Muscats. Various causes have been assigned to it, but the remedy is very decided—viz., to admit air rather freely, especially in the early part of the day and through the day, with a little at night, and a genial warmth in the pipes, so as to maintain a temperature of about 70° artificially. It is most prevalent towards the close of the stoning period, just before (a fortnight to three weeks) Grapes change colour for ripening. A slight shade is advantageous at this period and during the early stages of ripening, when the weather is very bright a double thickness of herring nets drawn over the roof lights being of great benefit in breaking the fierce rays of the sun from middle June to past the dog days, or mid-July.

**Muscats Ripening.**—These require time and assistance from fire heat so as to insure a night temperature of 70° to 75°, 85° to 90° by day, with abundance of air. They require a rather dry warm air, for under no other conditions will they attain to that golden hue characteristic of their inapproachable rich vinous flavour. Muscats also of all Grapes require very plentiful supplies of water when swelling their fruit. They can hardly be overdone with water at the roots after the leaves are full sized until the Grapes are well advanced in ripening, the border having thorough drainage, therefore attend well to the watering of inside borders, and outside also in dry weather. Too much atmospheric moisture, however, is fatal to Muscats when ripening, causing them to spot; therefore seek by a gentle warmth in the pipes and a little air constantly to prevent the deposition of moisture on the berries, surfacing the borders inside, after a final watering, with a few inches thickness of dry material.

**Shanking.**—This often causes great trouble through deterioration of crop. It is chiefly caused by suspended root-action at the critical period of the Grapes ripening, which may result from various errors. The first of these is deficiency of ventilation in the early stages of growth, combined with too much moisture, inducing long-jointed growth and thin foliage, or it may be the roots are deep in favourable rooting medium. To avoid shanking we must have properly made borders and well managed Vines, being careful to fully expose the foliage it forms to light and air, allowing no more than can have those essentials, not seeking to encourage root-action by a thicket of growth which must sooner or later be removed in quantity, and give a check accelerating the failure of supplies when most needed, but contrariwise keeping as much foliage as can have due exposure, and no more, in a healthy state, so that the supplies of nutriment may be steadily maintained. Shanking is strictly cultural, and as such avoidable by judicious treatment. Vines prone to shank should be given time, also avoid sudden fluctuations of temperature, particular attention being given to the ventilation, thereby securing a constant supply of nutriment, not only for the formation of starch, but that still further process of ripening, and by which it is converted into sugar. Regulate the young growths, adopting the extension rather than the restrictive system where there is room for it without crowding, keeping all gross laterals stopped so as to cause an equal flow of sap throughout the Vines, and this will do much to prevent the liability to shank.

**Young Vines.**—Those of this season's planting should, provided the light is not too much obstructed, be allowed to grow unchecked, it being presumed that they will be cut back to the bottom of the trellis, or to three or four eyes, at the winter dressing. Any super-numeraries intended for next year's fruiting should be regularly stopped at a length of 7 or 8 feet, removing the laterals from the buds intended to give fruit next year, preserving the old leaves, and as the wood will require thorough ripening, a free circulation of air will be necessary, with fire heat if the weather be cold and wet. The border should be well mulched and duly watered right up to the neck or collar, with a view to obtain and encourage the growth of adventitious roots, which are highly favourable to a strong break the following season.

**Vines in Pots.**—Those intended for fruiting next season should by this time have completed their growth, especially those required for early forcing, which should have no more water than will prevent the foliage from becoming limp, and they should be exposed to all the light and sun possible, so as to thoroughly ripen the wood and the buds. Keep the Vines free from insects, as it is very important that the leaves perform their functions. After the wood becomes brown and hard the Vines may be stood in front of a wall with a south aspect, securing the canes to the wall to prevent the foliage being damaged by wind.

## PLANT HOUSES.

**Calanthes.**—Where large pseudo-bulbs were placed to start them into moderately small pots they may, without further delay, be placed into the size in which they are intended to flower. This should always be done before the first pots become unduly crowded with roots, or the new compost will not prove of much benefit to the plants. Large pots for these useful plants are not desirable, for they do not require a large mass of soil in which to root. Plenty of room should be left in the pots, so that liberal supplies of water can be given. When the pots in which they are growing become full of roots feed them with weak stimulants every time they need water. The plants should be arranged close to the glass, and a close moist atmosphere maintained about them. Be careful to shade the foliage from the sun, but admit every ray of light possible to solidify the growth as it is developed. Any plants in a backward state must be pushed forward, so that their growth can be thoroughly ripened before the short sunless days of autumn. The immature ripening of the pseudo-bulbs means weak growth another year.

**Cypripedium insigne.**—Plants that have been assisted after flowering to make their growth, by introducing them for several years in succession into vineries and other warm structures, will by this time have developed their growth. Plants that have been trained to flower early, and now in this condition, need very careful treatment, or their flower spathes will soon be visible and the plants in full flower in October. They are much more useful from the end of November, and will then last in perfection in the conservatory during December and January, the two worst months in the year for flowers. Remove the plants into cold frames with a northern aspect, which will retard them wonderfully; in fact, their growth under these conditions will appear stationary and no injury to the plants will result. Syringe the foliage, and water the plants at their roots liberally while in this position. *C. villosum*, *C. Sedeni*, and other strong varieties will be growing freely, and if their pots or pans are full of roots they will be benefited by a little stimulant. It must be applied in a weak state and perfectly clear. That made from cow manure is excellent, but all the solid matter should be allowed to settle at the bottom of the tub or tank in which it is prepared, or failing this it should be strained by passing it through some close tiffany or canvas.

**Dendrobium.**—Such species as *D. nobile*, *D. Wardianum*, and others that start early into growth will have fully lengthened their new pseudo-bulbs by this time. Remove all in this condition to the lightest end of the house, or to a slightly cooler structure, where they can be gradually

but thoroughly ripened. Maintain about them slightly drier conditions. It is a mistake to hurry them in this stage, for they are apt to start again into growth, which would have but little chance of maturing before winter. Soft, unripened growths are almost certain to damp off during the resting period. A lower and drier atmosphere will prevent a second growth and give the pseudo-bulbs every chance of ripening thoroughly, which is the secret of their flowering well from every joint. All still growing should be encouraged as much as possible, to prevent the too-frequent practice of trying to ripen them when they should be enjoying a period of complete rest. More Dendrobiums after they have been imported a few years dwindle and die because they are not thoroughly ripened and rested than from any other cause. By the achievement of these ends there is every prospect of the plants increasing annually in strength and vigour.

*Thunias*.—The majority will have flowered unless they have been started late or retarded. Every endeavour should now be made to ripen well their new pseudo-bulbs. Well ripened growths are certain to pass the winter safely and grow and flower well the following season, while those drawn up soft and weakly and retained in a close, moist, shaded atmosphere will fail to flower another year if they do not rot during the winter. The early plants will have every opportunity in a light position to ripen, while the later ones must be well cared for to enable them to do so.

*Odontoglossums*.—Of late it has been difficult to keep the temperature in this department sufficiently low for the well-being of these plants; that is, where the structures are exposed either on one side or the other to the sun. A good quantity of air should be left on all night and increased early in the morning. The blinds should be drawn down at the same time, by these means only can the temperature be kept moderately low. The greatest difficulty in most structures when freely ventilated during hot dry weather is to maintain about the plants the requisite amount of moisture. Every care must be exercised in this matter, or the plants will suffer worse from dry atmospheric conditions than from the temperature rising high. If plenty of moisture has been supplied the moss will have grown luxuriantly, and may now be clipped round with a pair of shears. That removed may be utilised for top-dressing those upon which the moss has failed to grow well. Cattleyas that were not mossed when potted in spring can be done now, or any other Orchids in any of the departments that require doing. Any that have been previously mossed should have the dead and decaying moss removed before that in a living state is placed on the surface of the pots.

## THE BEE-KEEPER.

### APIARIAN NOTES AND HINTS TO INQUIRERS. ALBINO BEES.

A CORRESPONDENT and reader of this Journal asks my opinion of albino bees. I have no experience whatever of these bees; but from descriptions and what bees I had sent me about the same time from Italy that the American discovered the albino bee, mine answering the description of the American ones, I am of the opinion that the albino is a cross with a variety of the eastern races of bees.

When any of the coloured bees are once crossed and then bred back to the original they are commonly lighter in colour. That, and the reputed good working qualities which they appear to possess, tally with my own experience that they have either Cyprian or Syrian blood in them.

### INFORMATION FOR BEGINNERS.

The same and other correspondents, novices in bee-keeping, ask many queries which are difficult to answer privately, and as some of them are interesting, I thought it better to give the information wanted through the pages of the Journal. I will therefore as introductory give

### NOTES FROM MY OWN APIARY.

The heat since the 14th June has been excessive—rather too much so for abundant honey gathering, although on the morning of the 21st June the thermometer stood at 30° Fahrenheit, after which we have had a night temperature of from 40° to 50° and a day temperature of from 75° to 87° in the shade, taxing all resources to prevent swarming and supply the bees with sufficient super room, as by the 27th June every super was occupied,

and I was not in a fit state to make others, and unwilling to buy. Owing to this some of my best hives swarmed, and what a trouble this warm season with so many stray swarms and stranger bees flying about. Many queens were killed by these bees, while other swarms, owing to the queens being encased, abandoned their hives after being placed in them. I have only lost one queen by this, but my near neighbour out of a dozen swarms has only one spared, and every bee-keeper about here has experienced loss and annoyance. A Carniolian swarm occupied me for six hours before it settled, and after I had it secured the queen left three or four times; she was encased, and I suppose terror caused her to fly for safety. Before I had her secured the first time she flew about from twig to twig after the fashion of a bird in the bright sunshine, and travelled a long distance from the apiary. During her flight my neighbour had two or three swarms: the queens were all killed, the bees flying about and attempting an entrance to other hives. When I had fears of queen-encasement I closed the entrance for a little, and slipped in a carbolicised paper where the queen was likely to be. This puts the bees into confusion, and they become excited. When long enough in this state, and before suffocation commences, I open the ventilator, then when calmed down open the doorway.

### AMOUNT OF HONEY GATHERED.

Your Notts correspondent was anxious to know the amount of honey gathered by foreign bees. July is commonly our honey-gathering month. I am recording the doings in June only. Honey-gathering began on the 14th, but owing to the excessive heat the honey was neither so plentiful as it would have been had it been cooler, nor if we were situated in a more salubrious and lower lying pasture. My best stock of crossed Cyprians rose from 134 lbs. on the 18th June to 200 lbs. or more on the 30th. As our steelyard weighs that only I am not exaggerating the weight. A friend to whom I gave one has a stock much heavier.

Carniolians are also making great weight and doing well, especially so the nuclei with so few bees during winter that I made mention of before. One of these gave the first swarm, and one that occupied one Stewarton box only the last day of May is now occupying three body boxes and three supers sealed ready for the fourth and fifth, while I observe much honey in the bottom box. I have hitherto been of the opinion that three body boxes were nearly the right number, but judging from others occupying at least space equal to four I am of opinion that to prevent swarming and keep the bees at work they will require 5000 cubic inches of body space. This may seem too large, but when we take into account the prolificness of foreign bees, together with their honey-gathering qualities, as well as the room they require for breathing space, it will not in my opinion be a bit too large. Nine-tenths of the hives in use are not only too small, but they are in many cases not half large enough. We all know how slow bee-keepers were to advance from the old-fashioned bell-shaped straw hive of about 1500 cubic inches internal capacity, and the same stubbornness still exists amongst many bee-keepers regarding foreign bees and the size of hive they require in a good season, and adopting what would benefit both themselves and their bees. So prolific are some of these foreign bees that two swarms of Syrian first crosses that went together weighed 18 lbs. I do not remember seeing so large a number of bees in one swarm, and, judging from the weight of it since it was hived, it is rising in weight as rapidly as the crossed Cyprians are



doing. A crossed Syrian gave me the first sealed super after the crossed Cyprian, and a pure Syrian swarm will give me the first supers from swarms of this year.

#### SINGLE-CASED HIVES.

These are dryer in winter and cooler in summer than double-cased ones. Archangel mats hung loosely around the former make a capital shade, and when the hive is large enough and the ventilator in the floor opened the bees keep steadily at work, and do not swarm so readily as do those in double-cased hives of small dimensions and without any means of ventilating.

I have just overhauled a Syrian stock, and had to deprive it of some honey. Those who have seen my hives and those who read and believe this will have no difficulty in recognising the superiority of foreign bees and the system of management, and the urgency to adopt both. I could say a great deal more on behalf of foreign bees, but the object at present is to give such information as will put the beginner on equal terms to the most advanced.

For cheapness, simplicity, and effectiveness nothing can surpass the single-cased hive with its ventilating floor, iron cover, and a slight covering on sides, with ample on top of some non-conductive material. A step in advance is the "rig and fur" outside case, which may be plain or as ornate as desired. These cases keep the hives dry and airy at all times.

The floor (perhaps the most important part of a hive) admits of improvement. The plan of "F. M., Dumfriesshire," of using peat is a decided improvement for absorbing damp and preventing it ascending and again entering the hive. Turf for covering hives is unequalled. Hives ought to be provided with a stand, but fixed legs are a mistake. The stand and ventilating floor in one gives every advantage, and to have that perfect the inner sides of stand and false bottom or shutter ought also to be lined with zinc, having a tap at lower and back of floor to draw off the condensed moisture, which in strong hives even during summer is great and astonishing.

With but few exceptions all my hives at the present time are as strong in bees as the 18 lb. lot, and by the end of July my stock will have increased to two-thirds more than I require for another season. How am I get rid of the surplus to join such enormous stocks? Either to risk the sending to the Heather or at the fall would be simply folly; and all the more so when we take into consideration the fact that while mere nuclei of a few thousands of bees have lived through winter, consuming little food, and are now the weightiest hives, or as weighty as those strong ones that were always strong but have consumed much more meat, and now with not more surplus. Who will solve the problem how to get rid of the surplus stock in a profitable point of view as well as a humane one, without that sensational nonsense of "saving condemned bees?" If I had youth on my side I might try the experiment at home, or if it were not for the expense would join at the moors; but who could handle such hives if the season was a favourable one? Others beside myself are in want of information how to get rid of what we sometimes term too much of a good thing.

The beginner, however, may weigh the foregoing well in his mind, and as the year advances I will give practical advice how to make the best and most of the industrious and willing working bees.—A LANARKSHIRE BEE-KEEPER.

#### BEE-KEEPING QUERIES.

1. IN removing supers, before lifting them off the hive, if a piece of brown paper saturated with a carbolic solution is pushed down from top

between combs, will the bees move down to the hive—the bees all leaving the super?

2. If, before manipulating bees, the face and hands are washed with carbolic solution, will it prevent stinging?

3. Hints as to putting on and removing supers would be acceptable.

4. Should all supers be removed end of July till Heather is in bloom?  
—NOM DE PLUME.

[1. Crude carbolic acid should be painted slightly on stiffish brown paper, and if these be pushed between combs, sections, supers, or frames the bees will retreat from them instantly.

2. Carbolic acid on any part of the body does not prevent their stinging, as the body cannot bear being so frequently carbolicised. Warm weather, when the bees are full of honey, is the best time to manipulate, and when bees are not inclined to sting; but with the aid of carbolic acid, judiciously used, we can manipulate at any time without getting stung. It is desirable to wear a veil, and the German mask as sold by G. Neighbour & Sons is the best. Heavy netting, or dyed cloth of any kind, as well as loose garments dangling near the bees, irritates them much, stinging the cloth, leaving their stings behind, which aggravates the case and makes the bees furious. Gloves have the same effect. A feather kept in the hand or in a convenient place saturated with the acid, to be ready during all manipulations, to be applied at the proper time and place, has more effect than anything yet known in pacifying bees.

3. We intend giving some practical hints from our own apiary at an early date, which will cover this query better than a direct answer to it. Strong hives and successful supering go together. By keeping bees in non-swarving hives with little drone comb and a young queen are the first requirements, giving room in advance of the wants of the bees. A crowded hive never works satisfactorily. Ventilate below during hot weather as well as to shade. Fresh cut grass or wet cloths placed upon, and an occasional syringing over the hive, all tend to keep the bees cool and at work. As a rule, it is better to put empty supers uppermost, but this year has been favourable to the opposite. As you use small supers, the better way to manage them is to put on one cover and, immediately the combs are well begun, lift the two front ones and place them on the top of the back ones, and then put empty ones in the place of those removed. By following this course, the first finished supers are easily removed; and there is nothing better to prevent swarming than depriving the bees of honey. When hives are kept on the non-swarving principle, there are mostly plenty of swarms for the requirements of the bee-keeper and apiary—such as giving advantages for raising young queens and removing old combs.

4. It depends altogether on the weather. Sometimes supers are filled on till the Heather is in bloom, and sometimes there is an interval of some weeks. All half-filled Clover supers should be removed so as to have a pure sample of Heather honey.—A. L. B.]



## TO CORRESPONDENTS

\* \* \* All correspondence should be directed either to "THE EDITOR" or to "THE PUBLISHER." Letters addressed to Dr. Hogg or members of the staff often remain unopened unavoidably. We request that no one will write privately to any of our correspondents, as doing so subjects them to unjustifiable trouble and expense.

Correspondents should not mix up on the same sheet questions relating to Gardening and those on Bee subjects, and should never send more than two or three questions at once. All articles intended for insertion should be written on one side of the paper only. We cannot reply to questions through the post, and we do not undertake to return rejected communications.

**LATE INQUIRIES.**—It is necessary to again remind correspondents that letters arriving on WEDNESDAY MORNING cannot be answered in the "next issue," which is then far advanced for press.

**Black Currants Unhealthy** (*Old Subscriber*).—We regret to say your bushes are attacked with the Currant bud mite (*Phytophthora Ribis*), which affects the buds in the manner represented in the engraving on page 391 of our issue of May 19th of the present year. Hundreds of Black Currant bushes have been ruined by the mite, and, so far as we know, no remedy has been discovered for its extirpation.

**Campanulate Foxglove** (*Miss Mainwaring*).—We have seen several flowers similar to the one you enclose, though they can scarcely be said to be common. You would see a rather striking example of the same kind figured on page 5, last week. We remember seeing about twenty plants in one garden bearing a terminal campanulate flower, but in subsequent years the flowers in the same garden were of the normal type.

**Lemon Kidney Potatoes (F. J.).**—Your letter is really an advertisement, and it is not the rule to publish requests for articles unless they are rare and not wanted for commercial purposes. As you have grown the variety for many years, and have it true, you cannot do better than increase your stock. We know that Potatoes have been distributed under the name of Lemon Kidneys that were not true, though the senders of them thought them to be so. We know the variety very well, and esteem it an excellent selection of the Ashleaf Kidney. We think it is grown about Morecambe in Lancashire.

**Cropping Peach Trees (F. A.).**—Healthy vigorous trees will carry a fruit to each square foot of wall surface, and assuming that your trees grow freely, and are supplied with liquid manure, mulching them to encourage roots near the surface roots, the crop you name is permissible; still, if you perceive the strain on the trees is so great as to unduly check the growth of the trees you must remove the pressure by taking off some of the fruits from the weaker parts of the tree. Exercise good judgment in that respect, keeping the leaves clean, and all will be well.

**Thinning Apple Spurs (F. J.).**—It is a good plan to thin out the spurs where too thick, as by so doing the leaves on those retained have more space for assimilating the sap through the greater advantages of light and air; in fact, it very often makes all the difference between the spurs forming fruit buds or not. It, however, requires to be done with judgment, as too free thinning of the spurs on free-growing trees may force the buds on the spurs retained into growth, besides a reservation should be made of spur buds other than those wanted to form fruit buds in the current year, so as to maintain a succession of crops.

**Chrysanthemums (F. S.).**—If you top the plants now you will increase the number of growths, but diminish the size and impair the quality of the blooms. If you prefer few and fine blooms do not top the plants, but pinch out the axillary growths that push from the stems, taking care that the plants do not suffer by want of water at any time. An exposed sunny position is suitable. If plunged in ashes twist the pots round often to prevent a great extension of roots through the drainage. The less they root into the ashes the better. Very few of the "great growers" plunge the pots, but stand them on a thick firm layer of ashes impervious to worms. We presume you do not possess Mr. Molyneux's book. You would find it very useful on the question of setting the buds.

**Roses (Norice).**—Thin out small wiry looking growths now, cut back to about half their length any rather strong growths that have not flowered, also cut back those that have flowered to buds that appear starting, or bold buds on the stems, giving water copiously to the roots, and liquid manure if needed, then by keeping the shoots and foliage perfectly free from insects a second crop of flowers is produced by many varieties. Free growth is essential, and this can only be produced by healthy plants well supported with liquid food. We think it not unlikely that Mr. Gilmour may publish his practical articles to which you refer in pamphlet form. There appears to be a desire that he should do so. We agree with you that such a manual would be useful, and think it would meet with acceptance.

**Dissolving Bones (J. M.).**—About half the weight of the bones is required of sulphuric acid for their dissolving. The bones should be dry. Take of them 5 cwt., place on an earthen floor, and surround with a rim of fine dry ashes. Pour on the bones as much water as they will suck up without any standing, and then pour on it 2 cwt. of sulphuric acid. It will boil somewhat violently for a while. When this has subsided it will get tolerably solid, and the whole may be mixed together, ashes and all, and will be fit for use in a few days. If the superphosphate is required pure, then, of course, the ashes must not be mixed therewith. It is not necessary to break the bones. It is a very valuable manure. It is necessary that it be kept dry.

**Tomatoes (S. F.).**—Do not top the plants as you propose above the truss of flowers and take up a second shoot to be treated similarly, or you will lose much time in producing a good crop of fruit; but let them grow as long as they have head room—of course, inducing sturdy growth by assigning the plants a light position and taking care they have plenty of air. All you have to do then is to take out the axillary growths when they are an inch long or so, not pinching them back to a leaf, but removing them entirely, leaving only the fruit and foliage on the main stem. Plants treated in that way have produced stems 15 feet long, with clusters of fruit their entire length; and we have had others similarly treated as regards pinching the side growths bear heavily when topped at a height of 4 or 5 feet, this being necessary because there was not room for further extension.

**Preserving Kidney Beans (J. F.).**—We have not preserved the small-podded Dwarf Kidney Beans, but have preserved the stout fleshy pods of Scarlet Runner Beans in salt. They are gathered when still crisp and dry, placed in layers 2 inches thick or so in stone jars, the first layer resting on salt, and each layer just covered with it as the packing proceeds. Previous to use in winter the pods are soaked for several hours, or a night, then placing them in fresh water for a hour or two before cooking. We think there would be a possibility of the smaller Beans getting too salt by remaining in the jars a long time—that is, if salted down now and left till the winter. The pods of Scarlet Runners, besides being much more fleshy, have not to remain in the jars so long, as they are only packed in them in late autumn, and properly prepared and cooked they are very good till late in the following spring.

**Cucumber Plants Clubbing at the Roots (T. S.).**—The plants have the root disease, which is due to, in most cases, an excess of organic matter in the soil, especially vegetable or animal matter, generating humus, with its attendant nematoid germs. The corrective for this is to char the soil before use so as to destroy the nematoid germs, and also reduce the excess of organic matter over the inorganic, by which a more healthful plant is secured, safeguarding against disease; or, in the case of soil not full of vegetable matter or fibre, therefore not likely to contain the germ of disease, manures of a kind calculated to strengthen the plant in proportion to its vigour should be employed, as superphosphate (dissolved bones), soot, and wood ashes, so that lime, potash, &c. will be available for building up the plant's structure, which, with due regard to other cultural requirements, are

the only preventive measures that avail, remedial ones being of questionable efficacy through the disease being internal, and to reach it requires measures destructive of the plants. The only advice we can give is to root out the plants and soil, making a fresh start with healthy plants, fresh and sweet soil, observing cleanly culture.

**Enfeebled Roses (M. A. Bemham).**—Judging by the leaves sent the Roses must be in a very exhausted state, and they have been nearly devoured by insects. They have not been syringed half freely and often enough, and the "periodical manure waterings" have not been nearly adequate to sustain healthy growth. Being near a wall the soil is quite dry a foot or more below the surface, and poor. Nothing less than 2 gallons of water to each square foot of surface, followed the next day with the same quantity of liquid manure, can be of real benefit to your Roses, following while the ground is wet with a covering of 4 inches of manure for retaining the moisture and curbing the surface. The Roses should also be violently syringed every evening. By carrying out the practice indicated there is reason to hope that improvement would follow. The ground must be made moist right down to the subsoil and kept moist and that can only be done by very heavy waterings indeed, and mulchings. If the water will not enter the ground, drive stakes down here and there, making deep cavities, and fill these with water, and over again till the ground is saturated.

**Liquorice Culture (Seer).**—We have grown Liquorice satisfactorily according to the method described in Thompson's "Gardener's Assistant." It succeeds best in deep, rich, and rather sandy soils, or in an alluvial one. The ground should be heavily manured the year previous to planting, in order that the manure may be completely decomposed; and it should either be trenched 3 feet deep in autumn, laid in ridges, and allowed to remain in that state till spring, or it may be trenched immediately before planting. The former method is the preferable one. Liquorice is propagated by portions of the creeping stem, commonly termed the creeping root, from 4 to 6 inches in length, each having two or three buds. These having been prepared, should be planted in February or early in March, in rows 3 feet apart, and 11 inches from each other in the row, covering with earth to the depth of 2 or 3 inches. Every year in November, when the sap has gone down, and the leaves have turned yellow, the old stems should be cut down with a pruning knife to the level of the ground. At this time also the creeping stems ought to be forked up and cut off close to the main stems, and preserved in sand or in heaps covered with straw and earth for future plantations. The ground between the rows should be forked occasionally, and be kept free of weeds. The roots will be ready for taking up three years after planting. This should be done in winter after the descent of the sap. A trench about 3 feet deep must then be cast out, and a rope being fastened round the top the roots should be pulled up, after which they may be stored in sand for use; or if there is a large quantity they may be kept in pits like Potatoes.

**Begonias Unhealthy (Savoring).**—In the first place we may inform you that we have had good Begonias six years old, bushes 4 feet high and as much in diameter, bearing, say, 500 flowers, but we have also had the tubers of other varieties canker before they have exceeded half that age. All the varieties are not equally vigorous; and some of the doubles less so than the singles. We have examined the leaves you have sent very carefully and can find no insects on them, and we do not imagine the pigeons that you have seen pecking the plants were attracted there by insects. We are of opinion that the root action of your plants is defective. This may have been caused by aged or impaired tubers, allowing the soil to get too dry at some time, causing some of the roots to shrivel, or too wet, causing them to decay. The effect on the plants would be the same, in all cases—namely, the evaporation of moisture from the leaves in bright weather would be in excess of the absorption by the comparatively inactive roots, with the inevitable result of portions of the leaves shrinking, eventually drying up near the edges, or in blotches, just as is the case with Vines under similar conditions that are "scorched." If your plant that is so badly affected in the outdoor vase has not been long there, or, in other words, if it was approaching the flowering stage when put out, we have small doubt that we have indicated the cause of the injury. The dry air of your drawing room would also excite rapid transpiration, and the plants in theinery would be much more liable to suffer in the same way on dry stages than on a close and rather damp base. The best and healthiest of plants we have seen are either stood on a close base or partially plunged in ashes from which moisture steadily rises, currents of dry air passing upwards and in contact with the under side of the leaves being as injurious to Begonias as to Cinerarias and Calceolarias. We have, as you will admit, given particular attention to your case, though we shall not be surprised to learn that our views are not in complete accord with your own. We are sorry your plants are in such an unfortunate state, and should only be too glad if we could point out a remedy. We think we could have prevented the evil, unless the tubers were enfeebled, but we fear it is now so aggravated that a cure is practically impossible. Try the effect of standing some of the plants on the north side of a wall, never letting the roots get dry before water is given, and keep the ashes damp on which the pots stand. The double flowers sent are very small indeed, and indicate that they have not had the requisite support. If the tubers are not sound, strong healthy plants could not be expected. The most extensive and successful cultivators of Begonias are constantly raising fresh plants from seed, these being more vigorous than plants raised from cuttings, and, as a rule, the most vigorous plants and finest blooms are the produce of tubers two or three years old, and only a few very robust sorts continue healthy seven or eight years.

**Names of Plants.**—We only undertake to name species of plants, not varieties that have originated from seed and termed florists' flowers. Flowering specimens are necessary of flowering plants, and Fern fronds should bear spores. Specimens should arrive in a fresh state in firm boxes. Slightly damp moss or soft green leaves form the best packing, dry cotton wool the worst. Not more than six specimens can be named at once. (*Tree*).—2, *Spiræa Filipendula flore-pleno*; 5, *Monarda didyma*; 6, *Agrostemma flos-Jovis*; 13, *Polemonium cœruleum*; 23, *Hemerocallis fulva*. (*W. W.*).—The name of the Orchid with the long leaf was given on page 475; it is *Scuticaria Hadweni*. The other is a very fine variety

of *Oncidium dasystyle*. (A. D.)—3, *Platycodon grandiflorum*; 4, *Campanula carpatica*; 5, *Campanula rapunculoides*; 6, *Campanula glomerata*; 7, *Astrantia major*; 8, *Stachys Betonica fl.-albo*. (B. C.)—1, *Lastrea spinulosa*; 2, *Lastrea Filix-mas*; 3, *Lastrea dilatata*; 4, *Athyrium Filix-femina*; 5, Appears to be a stunted form of *Lastrea oreopteris*; 6, *Polystichum aculeatum*.

COVENT GARDEN MARKET.—JULY 13TH.

No alteration, large supplies reaching us. Trade as last week.

FRUIT.

	s.	d.	s.	d.		s.	d.	s.	d.
Apples, 1/2 sieve .. ..	0	0	0	0	Oranges, per 100 .. ..	6	0	12	0
Nova Scotia and Canada barre	10	0	13	0	Peaches, dozen .. ..	4	0	10	0
Cherries, 1/2 sieve .. ..	5	0	6	0	Pears, dozen .. ..	0	0	0	0
Cobs, 100 lbs. .. ..	0	0	0	0	Pine Apples, English, per lb. .. ..	1	6	0	0
Fig, dozen .. ..	3	0	4	0	Plums, 1/2 sieve .. ..	0	0	0	0
Grapes, per lb. .. ..	1	6	2	6	St. Michael Pine, each	3	0	6	0
Lemon, case .. ..	10	0	15	0	Strawberries, per lb. ..	0	3	0	10
Melon, each .. ..	2	0	3	0					

VEGETABLES.

	s.	d.	s.	d.		s.	d.	s.	d.	
Artichoke, dozen .. ..	1	0	2	0	Lettuce, dozen .. ..	0	9	to	12	0
Asparagus, bundle .. ..	1	6	4	0	Mushrooms, punnet .. ..	0	6	1	0	0
Beans, Kidney, per lb. ..	1	3	0	0	Mustard and Cress, punt.	0	2	0	6	0
Beet, Red, dozen .. ..	1	0	2	0	Onions, bunch .. ..	0	3	0	6	0
Broccoli, bundle .. ..	0	0	0	0	Parsley, dozen bunches	2	0	5	0	0
Brussels Sprouts, 1/2 sieve	0	0	0	0	Parsnips, dozen .. ..	1	0	0	0	0
Cabbage, dozen .. ..	1	6	0	0	Potatoes, per cwt. .. ..	4	0	5	0	0
Capicum, per 100 .. ..	1	6	2	0	Kidney, per cwt.	4	0	0	0	0
Carrots, bunch .. ..	0	4	0	0	Rhubarb, bundle .. ..	0	2	0	0	0
Cauliflowers, dozen .. ..	3	0	4	0	Salsafy, bundle .. ..	1	0	1	6	0
Celery, bundle .. ..	1	6	2	0	Scorzouera, bundle .. ..	1	6	0	0	0
Coleworts, doz. bunches	2	0	4	0	Scakale, basket .. ..	0	0	0	0	0
Cucumbers, each .. ..	0	4	0	6	Shallots, per lb. .. ..	0	3	0	0	0
Endive, dozen .. ..	1	0	2	0	Spinach, bushel .. ..	3	0	4	0	0
Herbs, bunch .. ..	0	2	0	0	Tomatoes, per lb. .. ..	0	6	0	9	0
Leeks, bunch .. ..	0	3	0	4	Turnips, bunch .. ..	0	4	0	6	0

PLANTS IN POTS.

	s.	d.	s.	d.		s.	d.	s.	d.	
Aralia Sieboldi, dozen ..	6	0	12	0	Fuchsia, dozen .. ..	3	0	to	9	0
Arbor vitae (golden) dozen	6	0	9	0	Geranium (Ivy), dozen ..	4	0	6	0	0
(common), dozen ..	0	0	0	0	Tricolor, dozen .. ..	3	0	6	0	0
Azalea, dozen .. ..	0	0	0	0	Hydrangea, dozen .. ..	9	0	12	0	0
Begonia, dozen .. ..	4	0	9	0	Lilies Valley, dozen .. ..	0	0	0	0	0
Calceolaria, dozen .. ..	3	6	8	0	Lilium lancifolium, doz. 12	0	0	18	0	0
Cineraria, dozen .. ..	0	0	0	0	longiflorum, doz. 18	0	0	30	0	0
Creeping Jenny, dozen ..	3	0	4	0	Lobelia, dozen .. ..	3	0	5	0	0
Dracena terminalis, doz. 30	0	60	0	0	Marguerite Daisy, dozen	6	0	12	0	0
viridis, dozen .. ..	12	0	24	0	Musk, dozen .. ..	2	0	4	0	0
Erica, various, dozen ..	13	0	24	0	Myrtles, dozen .. ..	6	0	12	0	0
Euonymus, in var., dozen	6	0	18	0	Palms, in var., each .. ..	2	6	21	0	0
Evergreens, in var., dozen	6	0	24	0	Pelargoniums, dozen .. ..	6	0	15	0	0
Ferns, in variety, dozen	4	0	18	0	scarlet, doz. .. ..	3	0	9	0	0
Ficus elastica, each ..	1	6	7	0	Spiraea, dozen .. ..	6	0	12	0	0
Foliage Plants, var., each	2	0	10	0						

CUT FLOWERS.

	s.	d.	s.	d.		s.	d.	s.	d.		
Abutilons, 12 bunches ..	2	0	to	4	0	Margnerites, 12 bunches	2	0	to	6	0
Anemones, 12 bunches ..	0	0	0	0	Mignonette, 12 bunches	2	0	4	0	0	
Arm Lilies, 12 blooms ..	3	0	6	0	Myosotis, 12 bunches ..	2	0	3	0	0	
Azalea, 12 sprays .. ..	0	0	0	0	Narciss, 12 bunches .. ..	0	0	0	0	0	
Bluebells, 12 bunches ..	0	0	0	0	White, English, bch.	0	0	0	0	0	
Bouvardias, bunch .. ..	0	6	1	0	Pansies, 12 bunches .. ..	2	0	4	0	0	
Camellias, blooms .. ..	0	0	0	0	Peas, Sweet, 12 bunches ..	3	0	6	0	0	
Carnations, 12 blooms ..	1	0	2	0	Pelargoniums, 12 trusses	0	9	1	0	0	
12 bunches .. ..	4	0	6	0	scarlet, 12 trusses	0	4	0	6	0	
Cornflower, 12 bunches ..	1	6	3	0	Pinks, White, 12 bunches	1	0	4	0	0	
Daisies, 12 bunches .. ..	2	0	4	0	various, 12 bunch	2	0	4	0	0	
Encharis, dozen .. ..	4	0	6	0	Paeony, 12 bunches .. ..	0	0	0	0	0	
Gardenias, 12 blooms ..	1	6	5	0	Poinsettia, 12 blooms ..	0	0	0	0	0	
Hyacinths, Roman, 12					Primula (single), bunch ..	0	0	0	0	0	
sprays .. ..	0	0	0	0	(double), bunch .. ..	0	9	1	0	0	
Iris, 12 bunches .. ..	2	0	9	0	Polyanthus, 12 bunches ..	0	0	0	0	0	
Lspageria, white, 12					Ranunculus, 12 bunches ..	0	0	0	0	0	
blooms .. ..	0	0	0	0	Roses, 12 bunches .. ..	2	0	6	0	0	
Lilium longiflorum, 12					(ladour), dozen .. ..	0	9	1	0	0	
blooms .. ..	3	0	6	0	Tea, dozen .. ..	1	6	3	0	0	
Lilac (white), French,					red dozen .. ..	0	0	0	0	0	
bunch .. ..	0	0	0	0	de Mois, 12 hanches	0	0	0	0	0	
Lilies, White, 12 bunches	12	0	24	0	Stephanotis, 12 sprays ..	1	6	8	0	0	
Orange, 12 bunches	9	0	12	0	Tropaeolum, 12 bunches	1	0	2	0	0	
Lily of Valley, 12 spray	0	0	0	0	Tuberose, 12 blooms ..	0	6	1	0	0	
"    "    12 bunches	0	0	0	0	Tulips, dozen blooms ..	0	0	0	0	0	

expressions of congratulation and thanks have reached us—not from one locality, but from several. We mention this in proof of the high value for general use of home-mixed chemical manures. It is said, and rightly so, that to use the same mixture in given quantities for every farm involves some—often much—waste, yet by a few experiments any farmer may see in a single season how best to arrange the proportions of the mixture for his particular farm. No doubt chemical analysis is useful, but it is very seldom called for if a farmer will but apply the test to his soil in the way we suggest. He may go farther and try other manures, not unfrequently with benefit to himself. For example, we have repeatedly made mention of nitrate of potash, nitrate of soda, mineral superphosphate, and steamed bone flour as being when mixed an excellent manure for pasture. Undoubtedly it is so, for we have used it for several years upon many farms with remarkable success. This year it was used by an amateur farmer in February upon a new piece of permanent pasture laid down last year. The result has been so extraordinary, the growth of the young pasture so abundant, that he is disgusted with the comparatively bare aspect of his old pasture, and has asked our advice as to whether he ought not to break it up and sow it with a carefully selected mixture of the best sorts of Grass and Clover. Instead of doing so we recommend him to retain the old pasture intact, and to apply a dressing of the chemical manure to it next February, for it is only in exceptional cases that we ever should destroy old pasture.

In our own practice this year upon grass land we have used muriate of potash instead of nitrate of potash, and have reason to adopt this change altogether in future, as it enables us to insure an abundant crop at a much less cost than when we used the nitrate of potash. We shall probably still farther modify our original recipe, and discard mineral superphosphate if we are able to procure a pure sample of steamed bone flour. If we cannot do so, and have to use ordinary bone flour, then a certain quantity of mineral superphosphate would be mixed with the bone flour a few days before using it, in order that the sulphuric acid with which the coprolite is saturated may act upon the bone dust, and render it soluble much sooner than it would otherwise be.

To new readers of the Journal we may explain that although mention is made of chemical manures now, they are not used upon pasture at this season of the year, but in February or early in spring. It is to results that we call attention now while they are before us, so that we may be able to see if any improvement in practice is possible for another year. But though we do not use chemical manures now, sheep-folding may be said to go on throughout the year. Very much of the redundant growth of the forage crops now in the process of being made into hay is solely the outcome of sheep-folding last year, and so far as is practical the sheep are always kept in folds to enrich the soil in a thorough and systematic manner. Of forage crops on arable land there is none more useful or profitable than Perennial Rye Grass; sown with a corn crop it affords us an admirable supply of green food early in the following spring, and which is available for sheep-folding, for cattle and horses, and for hay. In deep fertile land it yields a wonderful bulk of crops per acre, the second growth often being as abundant as the first. As hay it is very useful; one special purpose to which we apply it is for chaffing for the ewes' consumption both before and after lambing. It is either used alone or mixed with Oat or Barley straw chaff for them according to the condition of the ewes. So



FORAGE CROPS.

As the season for the work comes round, year after year have we for some time now called the particular attention of our readers to the use of chemical manures for the improvement of permanent pasture. Gladly do we record the fact that the intelligent application of our advice to practice has led to results so satisfactory that



useful is it that we would have a few acres of it upon every farm both for grazing and for hay; and all possible care should be taken to have the land in high condition for the culture of a crop so worthy of our best care. It forms an admirable successional crop to Rye in spring, and is of especial use for dairy cows then.

Local custom affects the way in which Rye Grass is sown. In East Anglia, where the climate is so favourable for the development and harvesting of Clover seed, the Rye Grass is sown alone, and upon some farms is still regarded as an annual, and is, like Red Clover, only retained for the two growths of the year after sowing, and is then ploughed in. The true perennial character of *Lolium perenne* is, however, getting better known, and the layers are gradually being left for a few years. For a heavy bulk of excellent forage the general plan of sowing it with Clover and *Trifolium* is altogether best.

WORK ON THE HOME FARM.

All sound lambs and sheep have been dipped in Cooper's dressing, which not only destroys all such parasites as ticks and lice, but, for a time, renders them less liable to suffer from attacks of fly. In hot, dry, summer weather, they should—even when so dressed—be examined at least once daily for fly, and if maggots are found in the fleece, a little of Cuff's dressing, poured and rubbed in, brings out and destroys every maggot. There is, undoubtedly, much negligence and brutality on the part of some shepherds, evidence of which is afforded in foul sores denuded of wool, lameness, and debility. If only one or two cases of fly-striking are discovered, the entire flock is carefully examined twice daily, and this is best done by connecting two small folds by means of a passage of hurdles, through which the sheep are made to pass as quietly as possible. The practical eye will then quickly discover symptoms of fly-striking in any sheep, and no doubtful case is passed over. The master's eye should very frequently overlook this process, and it should not be left to a shepherd's discretion till there is a feeling of certainty that he is really capable and trustworthy. We lay considerable stress upon this matter from the promptings of dear-bought experience. In point of fact, we have recently had to discharge a respectable, sober, steady man, whose conceit and obstinacy had led to such serious losses that we were reluctantly compelled to part with him.

Immediately after the lambs were weaned the whole of the ewes were carefully examined; barren ewes, forward in condition, were at once sold, and all others with any blemish were withdrawn from the flock to be fattened in folds as crones and gradually sold. Of such we took sixty from the home flock, which contains ewes of various ages, and we shall replace them with two-shear sheep selected with care from good flocks. It is wrong to retain a faulty ewe, for there is much risk of the loss of animals or their lambs next season. In dipping sheep care is taken to exclude any having sore udders or unhealed wounds caused in shearing. Every effort should now be made to eradicate foot-rot, and when this is done, be on the alert to discover and treat any fresh symptoms of it at once.

ROYAL AGRICULTURAL SHOW, NEWCASTLE-ON-TYNE.

The above Show opened on the 11th, and continued to the 15th inst., but we cannot do more than describe briefly the imposing seed stands arranged by the principal growers in England. They are of easy access, being disposed right and left near the entrance of the Show.

The first stand to the left is that of Messrs. Webb & Sons of Wordsley, Stourbridge. This splendid stand is 150 feet long, the various contents being most artistically displayed, showing to the observer what can be done by ingenuity and skill. Messrs. Webb & Sons show great quantities of seed from their Kinver Seed Farm. Amongst Potatoes we observed Wordsley Pride, Discovery, Renown, Red King, and others. Lawn Grasses are prominent, being shown in a growing state. Forage Grasses are also represented in a very complete manner, and all named botanically, hence the display is instructive. Seeds for foreign exportation are also shown, Messrs. Webb & Sons having a large branch establishment at New Zealand. The firm show case and tins of their own invention, which effectively protect the vitality of seeds when exported.

Messrs. Dickson, Brown, & Tait, Manchester, show an interesting collection of agricultural seeds, especially Grasses for permanent pasture. These are so arranged that the observer can see them in all stages, from the first growth to the development of the ripened seed.

The next stand is that of Messrs. Wm. Fell & Co., Hexham, local nurserymen, who also show a varied stand of agricultural and garden seeds. Grasses are shown in their natural state as collected from the woods around Hexham. This firm also exhibited a new *Lobelia* named Jubilee, which is very fine, resembling *pumila* in the growth, Brighton Blue in the flower. It may be added that Messrs. Fell were entrusted with the decorations of the pavilion where the Prince of Wales dined. The front of the verandah is covered with Vines in pots and variegated Ivies, producing a striking appearance, being relieved with *Pelargonium*, *Kalosanthes*, &c., and other greenhouse flowers.

Messrs. Robert Bell & Son, Newcastle, show a stand of purely agricultural seeds and manures.

Messrs. Dickson & Son, Manchester, show a very interesting collection of Grasses suitable for permanent pasture and alternate husbandry.

Going back to the entrance again, we come to the magnificent stand of Messrs. Sutton & Sons, Reading, Berks, which is seen to advantage from all parts of the Show. The stand is about 150 feet in length, roomy offices being provided at each end. There is a winding staircase which leads up to a balcony, this forming an agreeable promenade for the convenience of customers. Grass and lawn seeds are shown in varieties to suit all kinds of land, also for lawns and foreign exportation. Forage Grasses for silos form a prominent feature. Potatoes are shown, embracing all Sutton's recent introductions—such as *Magnum Bonum*, Sutton's Reading Hero, Sutton's Early Regent, and many others. Tobacco grown by themselves is represented in twelve varieties, recommended as suitable for growth in this country, but English Tobacco is not expected to equal the best foreign brands. A lawn sown with this year's seeds was very fine. All Sutton's recent introductions of vegetables are represented; the entire display being very interesting.

The next stand is that of Messrs. F. & A. Dickson & Sons, Chester; it is most interesting and varied, containing permanent Grasses and Clover of guaranteed excellence, also Grasses that are often injurious in pastures. Seed-cleaning is practically illustrating by machinery, so that the visitor has every advantage of leaving this stand with valuable information.

Messrs. Finney & Son, Newcastle, provide the next stand. This firm is a local one and a very old one, having commenced in 1749, Mr. R. G. Fort being now the proprietor. It includes new Winter Barley, which is sown in the autumn and eaten off with grass by the sheep in the spring. This Barley is represented as possessing capital malting qualities and ripens early in August in the north. The firm shows fine examples of Swedes grown in their trial grounds, being quite fresh and sound; also specimens of Tobacco grown in Durham.

Messrs. Oakshot & Millard, Reading, have a large and interesting stand. They show 200 varieties of Grass and Clover seeds; their lawn is very fine, sown with a mixture at the rate of 60 lbs. per acre. Grasses that are regarded as weeds are represented, and the entire exhibit is instructive to the initiated.

Messrs. James Carter & Co., High Holborn, London, have a most important stand, 130 feet long, showing their new Peas Anticipation, Electric Light, also Telephone and Stratagem. Onions very fine. There are also forty varieties of Tobacco, and some fine specimens of *Nasturtium* in pots render the stand very bright. *Agrostis pulchella* and *Hordeum jubatum* are shown in this stand as weeds, the former is very pretty and much appreciated for ladies' hair. This firm also exhibit Peas preserved in a natural state by Carter's process, which is now patented. All kinds of agricultural crops are also admirably represented, and the display in its entirety is excellent.

Messrs. James Dickson, 108, Eastgate Street, Chester, show a fine collection of seeds in great variety, as also do Messrs. Little and Ballantyne, Carlisle, their stand being decorated with fine plants of *Abies Alcoquiana*, *Biota elegantissima*, *Abies inverta*, *Arthrotaxus selaginoides*, *Abies Engelmani*, and other Conifers.

The seed stands form a most interesting feature in the Society's exhibits, and were crowded by well-known northern farmers and experts in agriculture. Messrs. Richardson & Co., Darlington, also Foster and Pearson, Chilwell, exhibit excellent glass structures.—B. C.

METEOROLOGICAL OBSERVATIONS.

CAMDEN SQUARE, LONDON.

Lat. 51° 32' 40" N.; Long. 0° 8' 0" W.; Altitude, 111 feet.

DATE.	9 A.M.					IN THE DAY.				Rain
	Barome- ter at Sea and Level.	Hygrome- ter.		Direction of Wind.	Temp. of soil at 1 foot.	Shade Tem- perature.		Radiation Temperature		
		Dry.	Wet.			Max.	Min.	In sun.	On grass	
1887.										
July.										
Sunday .....	30.217	73.8	62.7	S.E.	63.1	88.8	55.1	125.9	50.8	—
Monday .....	29.991	77.2	63.3	S.E.	64.3	85.3	58.9	133.4	52.4	0.037
Tuesday .....	29.926	62.8	56.0	N.W.	65.8	70.9	58.2	114.2	49.9	—
Wednesday .....	30.153	59.9	52.3	E.	64.7	75.6	51.3	122.6	45.1	—
Thursday .....	30.140	70.4	63.1	W.	64.5	81.9	57.8	128.6	52.7	—
Friday .....	30.069	74.7	62.1	S.	64.8	86.9	53.2	133.4	49.2	—
Saturday .....	29.926	65.6	60.2	N.E.	65.7	79.0	63.0	123.2	58.7	—
	30.060	69.2	60.7		64.7	81.6	56.8	126.3	51.3	0.037

REMARKS.

3rd.—Very hot and bright.  
 4th.—Very hot, particularly in the sun.  
 5th.—A little rain in the small hours, cold pleasant day, shady at times.  
 6th.—Bright and pleasant.  
 7th.—Fine, and generally bright, but rather close and oppressive.  
 8th.—Bright and hot.  
 9th.—Overcast early; frequently cloudy during morning; bright hot afternoon.  
 A very fine and hot week, although 9° was not reached in the shade, the average maximum, 81.6°, was higher than in any week for several years. The nearest approach was in the week ending August 16th, 1884, which gave the following values:—

	9 A.M.		Temp.	Shade.		Radiation.		
	Dry.	Wet.	At 1 foot.	Max.	Min.	Sun.	Grass.	Rain.
1884, August ..	69.1	62.4	66.9	81.2	58.5	118.9	53.8	0.040
1887, July ..	69.2	60.7	64.7	81.6	56.8	126.3	51.3	0.037
Difference ..	+ 0.1	- 1.7	- 2.2	+ 0.4	- 1.7	+ 7.4	- 2.5	- 0.003

Therefore this week has been rather hotter by day and rather cooler by night than the one quoted, but on the whole very similar. The sun temperatures last week were exceptionally high.—G. J. SYMONS.



## COMING EVENTS

21	TH	Highgate Show.
22	F	Quekett Club at 8 P.M.
23	S	Royal Botanic Society at 3.45 P.M.
24	SUN	7TH SUNDAY AFTER TRINITY.
25	M	Show at the People's Palace.
26	TU	Royal Horticultural Society—Fruit and Floral Committee at 11 A.M.
27	W	[National Carnation and Picnic Society's Show.]

### TRIALS OF PLANTS AND CROPS AT CHISWICK.

**A** NOTE in the Journal of last week referring to the Strawberries grown in the Royal Horticultural Society's Gardens induces me to bring the subject of the "trials" there conducted to the notice of the public generally, and the Council of the Society particularly.

A sentence in the note referred to on page 31 expresses exactly my own hope, desire, and views, and no doubt those of many others. It is the breathing of expectancy and the foreshadowing of utility in these words: "We may expect that a report of the Strawberries will be prepared for publication at some time, and it would be useful."

Unquestionably a carefully prepared official report would be useful, and it seems to me that authoritative "reports" of all trials that are conducted in the Gardens should be published as soon as possible after the results of the different varieties have been determined. We may expect the Strawberry report will be published at "some time;" but when? This policy of expectancy has, I respectfully submit, been pursued long enough, and we want more promptitude in action. As one of the several supporters of the Royal Horticultural Society who can seldom visit the Gardens, I cannot remain satisfied with the existing state of things. Trials of plants and crops have been held year by year, but of what benefit are they to those who cannot inspect them? It is presumed that systematic reports of all experiments are prepared and stored in the Society's archives pending the issue of some "Journal" or official medium for their publication and distribution, but we see none of these reports, the "expected" information does not appear. If I am in error in assuming that a careful digest of the trials is prepared by the committees, superintendent, secretary, or whoever may be the authorised compilers, and if nothing of the kind is done, then I am of opinion the Council of the Society cannot be entirely exonerated of laxity in what we may fairly consider the performance of their duties, for it is naturally expected the instructions issued by that distinguished body are carried out as far as is practicable. It is useless suggesting that an official should do this or that; no official is responsible for the conduct of the Society's affairs, but the Council, and to them belongs whatever of glory or the reverse that attaches to the position as measured by results.

The gardens at Chiswick are established for experimental purposes in the interests of horticulture and for the benefit of the Fellows who support them, and the general public; but what return do absentee supporters of the Society get if no information is placed

within their reach? At present, and for some time past, we have heard little or nothing about the proceedings in the Gardens in question beyond a scratch note from some casual visitor. Nothing official or authoritative is published, and so far as regards the great general public of horticulturists and persons interested in the pursuit which it is the first duty of the Royal Horticultural Society to promote, the Gardens might almost as well be closed if the proceedings in them are sealed from the great body of their supporters.

Is it too much to expect that the character of everything sent to Chiswick for trial should be estimated and recorded, and these records published on the responsibility of the respective committees in their capacity of juries? We want not the particulars alone of the few varieties to which honours are awarded, but of those that escape, it may be by a solitary vote, admission into the charmed circle. It may possibly be urged that preparing systematic descriptions of every variety included in the trials would be a work of such magnitude that it could not well be accomplished by the staff, but it has been done in the past, and most valuable the reports have been. Admitting, however, the force of the objection under present circumstances, is not the remedy in the hands of the Council? Cannot they limit the number of varieties sent by individuals so as to reduce the whole trials within reasonable, and, to coin a term, "workable" limits? It is surely better to do well than which may be undertaken than to incur liabilities that can only be discharged in a slipshod manner.

But apart from that, it can scarcely be considered satisfactory to allow any person to send as many varieties as he likes for trial in the Gardens, especially if only descriptions of those that may be certificated are published, for it is conceivable that nothing more would be heard of the others, and in that case the person contributing would alone benefit; indeed, the Society would be devoting space and incurring cost in the labour of cultivation which it has no right to bear. If there is no limit in respect to the number of Peas, Potatoes, or whatever may be on trial, the Society is liable to be placed in the not very dignified position of doing the work that raisers and introducers of novelties ought to do themselves, as they are the sole beneficiaries when the demerits as well as the merits of what they send are not published to the world. And the objection to the present state of things becomes intensified when varieties are tried and adjudicated upon under numbers. I am not able to refer to the rules of the Society, but have an impression that everything submitted to the Society's censors for examination must be named. That certainly would seem to be a reasonable provision; but is it not a fact that certificates have been granted to Potatoes and other things under numbers, and these numbers published in the gardening press? Of what possible use is that to the public? It is worse than useless, for it is tantalising. But whether the numbers are published or not, awards ought not to be made to any unnamed variety whatever, and nothing ought to be grown on trial in the Gardens without its name being attached from beginning to end.

When Fellows of the Society or their friends visit the Gardens they do so for purposes of instruction, and the first thing they look for is the names of the different varieties of flowers or vegetables that are included in the trials. I was in the Gardens a few weeks ago and looked in vain for the names of several new Peas that were advancing to maturity, and I have heard others complain

of this blind method of procedure. If it is right there must be some occult reason for it that is not apparent to ordinary visitors, and on this point perhaps the Council might vouchsafe a little information.

I am not writing to praise or to blame anyone whether in an individual or corporate capacity. There has been perhaps more than enough of that sort of thing, but I wish to have the whole system brought under review, for at present it appears to be in some respects faulty, not to say loose; and the opinion is gaining ground that the non-publication of complete systematic reports of the Chiswick trials is a mistake from whatever point of view the omission is regarded.

Wherever the head of the Royal Horticultural Society may be, Chiswick is its heart; and I am one of those who think it is a small matter as to whether the offices of the Society remain at South Kensington or not, in comparison with making the most and the best of the Gardens at Chiswick—doing all that can be done there as far as the Society's resources allow, and making the public acquainted with the proceedings in an official manner and without avoidable delay. This would do more than anything else to strengthen the Society and gain for it public sympathy and confidence, as records of the doings in the Gardens would afford proof that the Society is actively engaged in the work it was established to perform. A good deal is no doubt done in the gardens now, but what avails that if the great body of cultivators know nothing about it except what is casually gleaned from the observations of some visitor who happens to record his impressions in one or more of the gardening Journals?

That the Council of a Royal Society should be content with that haphazard method of placing its work before the public is a little surprising, and to say the least it betrays a lack of real active interest on the part of that body, and an absence of a genuine horticultural spirit that should animate every member and form the basis of his action in the conduct of the Society's affairs. It should be, and it can be, popularised, and in no way so well as in developing the resources of Chiswick, and placing the work that is being done there before the public as often and as quickly as the materials can be provided, and this would be much more frequently and promptly than has been the case during recent years. Official inactivity is largely interpreted as apathy, and can only represent a society in an enfeebled state.—A FELLOW.

## SHADING AND AIR-GIVING.

(Continued from page 30.)

A COOL temperature at night, and early air-giving, will minimise shading, and so far as growing and ripening are concerned, would render the process next to unnecessary, could we depend upon regular courses of weather. But in all shallow structures, such as pits and frames, shading is often required, when, after several days of dull, cloudy weather, one with bright sunshine suddenly comes. We see even hardy plants flag for several hours under such circumstances, and unless the preventives of early air-giving, and additional moisture in the atmosphere, have been attended to, the danger of scalding and burning would have been imminent, without shading, in all such structures.

A good syringing, or an hour's shading, will often habituate the plants to the change, and no crumpling or scalding of leaves will be the result. But this shading should never remain a moment longer than is necessary. It is nothing uncommon to meet with people that can only have one prominent idea at one time. They will never do great things in gardening, unless they are fixed to one department, and hardly even then. It is nothing uncommon to see a man careful in shading; but go hours after the sun has been clouded, and there is still the shading. The necessity of removing, as well as putting on, is a sort of double idea, and that was too

much for thorough attention. One of the cleverest men I ever knew never held a situation long from this very cause. Whatever he was doing was done well, because it received his undivided attention. There was no room for anything else, and the general results may be guessed at. There was praiseworthy attention to one object, but for all other things demanding equal care and thought, they might as well not have existed. Every minute's shading more than is necessary renders the plant more enervated, and just requiring more and more of future shading and coddling.

Having said sufficient of the principle to be kept in view in shading, let me now say a few words as to the modes and material. For though the hints thrown out would reduce shading to a minimum when growth and maturation were concerned, it becomes less or more indispensable when we wish to preserve plants in bloom as long as possible.

For this purpose nothing is better for houses than thin calico or open bunting, fixed by one side to the ridge of a house, and at the front side of the house to a round roller of wood, from 1½ to 2½ inches in diameter. In houses about 30 feet in length, a cord twice the width of the house, wrapped round a grooved wheel on the end of the roller, will be sufficient to let the roller up and down. As you pull the string, the resistance given will cause the roller to revolve and mount the roof, and by means of a pin in front it may be fixed at any elevation.

But even at the above length, or a little more, there will be a tendency in the roller and blind to drag at one end, and, therefore, in the cases of blinds over long houses, it is better to have two or three pulleys instead of one. The mode of working is quite as easy, but different. Each pulley will require to be from three to five times the width of the houses. Fix the blind on the apex of the roof and to the roller, respectively, as stated above. Then, supposing you are to have three pulleys, one near each end, and one in the middle, fix your pulley lines firmly in these places to the apex of the roof, then bring down the cord on the glass, underneath the shade, passing it over the wooden roller, and taking it back again to the apex, and passing it there through a pulley wheel, and bringing the end of the line down over the roof again, so that you can easily catch it by the hand. Do the end ones the same way, only in addition carry the cord from the pulley wheel along the apex of the roof, to another pulley wheel close to the centre, and bring down the cord over the roof in the same way as the first. You can thus take all three cords in your hand at once, by pulling which the blind will rise regularly from end to end, and you can fasten it at the top or any intermediate distance, by twisting the ropes round a post with a peg through it. When unloosed the weight of the roller will bring the blind down. On the same principle you may bring all the strings to one end, instead of the middle, and you may have as many pulley-strings as you like. Three would be quite ample for a length of 70 or 80 feet.

For pits, a similar plan may be used. Any mode, almost, is better than the littery mats we often use. I saw, the other day, a very simple and effectual mode in operation. Thin bleached calico was used. Each piece covers from four to eight or ten lights, according to the size of the pit. Each end is fastened to a rod of wood about half an inch in diameter, and a foot or two longer than the covering. On one of these the covering is rolled up when not wanted. When used, one rod is fixed at the end of the pit or frame. You stand at the front of the pit, hold the lower end of the other rod in your hands, and, placing the other end on the apex of the back of the pit, you turn it round, walking briskly along, and leaving the cloth on the glass as you proceed; the rod is then fixed at the other end. From having the rods longer than the pit you thus easily shade and unshade, without the rods ever touching the glass. On the cloth, opposite the handles of each light, there are strings sewed on, which, when tied to the handles, prevents any wind but a hurricane from moving it. The rods, besides being thus useful, are a great saving to the shade, as when not wanted, or in wet weather, they can easily be transported to a waterproofed shed. Any other cheap thin material, such as Nottingham netting, may be used in a similar manner.

Many, however, will object to the trouble even of these shades, and would prefer something that would give a mild continuous shade during summer. The other day I saw a house thickly encrusted with lime. The objection to this is, that if used at all in a quick state it will injure both paint and putty. Whiting is better. The objection to both is, that the first shower will wash them off. Hence I recommend double size, with the smallest amount of whiting—say the size of a walnut to more than a quart. I saw many of what had been fine blinds lying in a nursery, fast going to decay, lately, and the houses had been sized and whitened instead. The proprietor told me that it answered far better, and saved an immense number of mishaps and bother in mistakes about shading. He had, however, put his on on the inside of the glass, instead of



the outside, stating that when on the outside the rains washed it off. This, I believe, must have been owing to some mistake in the process. Besides, the moisture inside, especially when much of the syringe was used, would be apt to bring the material about the plants, and render them unsightly. In my own practice, I do not get rid of it until after the rains of autumn, when placed on the outside. Of course, a little whiting water, put on in a moment with the syringe, is washed off with the first shower. I may, therefore, repeat the essentials necessary for sizing the outside of the glass. Double or jelly size is used; that is heated nearly to boiling point, without any water being put with it. When the glass is thoroughly dry, and the sun not shining strong, it is put on the glass in the hot state, by means of a brush pulled briskly along it. This will give a roof resembling thin rough sheet. When a little more shade is wanted, the size of a marble of whiting is dissolved in the size, and when still more shade, the size of a walnut of that material. This sticks so fast, when so put on, that I have frequently had to use a little soda, in water just warmed, to remove it entirely when the dull days of autumn came.

From trying various experiments, I can recommend another mixture, chiefly the invention of a respectable young painter. The mixture is as follows:—One quart of water, one pound of size, the jelly kind, one pint of turpentine, the size of a walnut of whiting, and half a tablespoonful of oil, all blended together, well stirred, and put on with a brush when hot. I am just now looking into a small greenhouse with a west aspect so done. For the glass of the roof, the brush was dipped in the mixture and then pulled quickly along it. For the upright front sashes, the squares were thus painted, and then quickly daubed with the points of a dry brush, which gave it a slightly mottled appearance. When standing at a short distance, you cannot perceive that anything has been done to the glass, and yet in the strongest afternoon suns, the shade has been quite effectual, and secured a luxuriant blossom, in the case of Pelargoniums, Fuchsias, Cactus, &c. There seems no likelihood of rains washing it off. A damp from the syringe, and a rub with a cloth or brush, easily removes it. I think that the bloom is better coloured, and longer preserved, than by any other mode of continuous shading. A little goes a great way. The turpentine and oil prevent all danger to the paint. In dull weather you can scarcely perceive that the house is shaded. No cloth of any kind could do it so finely, and then all the trouble is saved. I do not think that more light will be wanted until the end of October.

## ROSE SHOWS.

### THE EDINBURGH SHOW OF THE NATIONAL ROSE SOCIETY.

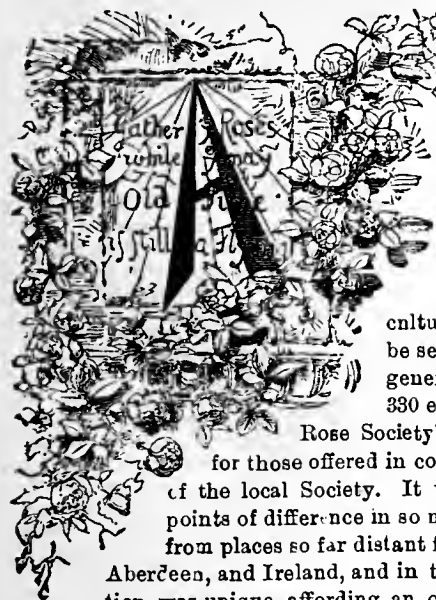

AFTER holding a number of provincial shows in England, for the first time in its history the National Rose Society ventured across the Tweed and held its provincial Show on Wednesday, the 13th inst., at Edinburgh, in connection with the summer Show of the Royal Caledonian Horticultural Society. The classes, as will be seen by the prize list following, were generally well filled. Something like 330 entries were made for the National Rose Society's prizes, and about another fifty for those offered in connection with the legitimate Show of the local Society. It was very interesting to note the points of difference in so many Roses, brought as they were from places so far distant from each other as Wales, Essex, Aberdeen, and Ireland, and in this feature, no doubt, the Exhibition was unique, affording an opportunity of comparison which has never occurred before. The English blooms were characterised by compactness of build, brilliancy of colour, and general high finish, wanting in the Irish and Scottish flowers, more particularly as referring to the darker coloured varieties. The blooms of the northern growers were fuller, looser, larger in petal, but in the case of the dark sorts altogether deficient in the richness of hue which gave the southern flowers so much of their charm. Owing to the rapidity of access from the south by means of the night trains, the English growers, though generally farther distant, had the advantage of their northern *confrères*, who in most cases would find it necessary to reach Edinburgh the evening previous to the Show. The blooms were staged and ready for the Judges in good time, the prize cards were placed on the boxes without unnecessary delay, and it goes without

saying that the Auld Reekie folks were delighted with the treat afforded them, and took advantage of it so fully as to render access to the tables a matter of some difficulty. It is regrettable that, owing mainly to the indiscretion of some of the exhibitors, the close of the Show was rendered somewhat unruly, visitors snatching the blooms out of the boxes and making matters uncomfortable for those who wished to save their blooms.

Undernoted is the prize list:—

#### NURSEYMEN'S CLASSES.

**Jubilee Class.** Thirty-six, distinct, single trusses, open to all nurserymen, the winner of the first prize will hold for the year a challenge trophy, value £50, and £3; second £3; third £2; fourth £1. For this valuable prize there were nine entries, the trophy being well won by Messrs. Harkness & Son, Bedale, Yorkshire, with blooms which, though not large, were very bright and fresh. The varieties staged were Etienne Levet, Pierre Notting, Alfred Colomb, Lady Mary Fitzwilliam, Star of Waltham, La France, Charles Lefebvre, Captain Christy, Louis Van Houtte, Merveille de Lyon, Duchesse de Morny, Beauty of Waltham, Madame Gabriel Luizet, Abel Carrière, Innocente Pirola (very fine), Duke of Connaught, Ulrich Brunner, Penelope Mayo, Maréchal Niel, Madame Hausmann, Comtesse de Nadaillac, Duc de Rohan, Queen of Queens, Dr. Andry, Jean Ducher, Marie Verdier, Catherine Mermet, Charles Darwin, Marie Finger, Marie Baumann, Baroness Rothschild, Harrison Weir, Annie Wood, Reynolds Hole, and Auguste Rigotard. Messrs. R. Mack & Son, Catterick Bridge, Yorkshire, were second with fresh buds, but smaller than the first prize; third Mr. B. R. Cant, Colchester; and fourth Mr. John Cranston, King's Acre, Hereford.

**Division A.**—Seventy-two, distinct, single trusses. First prize is a piece of plate presented by some amateur members of the Royal Caledonian Horticultural Society, with £4 added by the National Rose Society; second £5; third £3. There were six entries for the seventy two's, Messrs. Harkness & Sons repeating their victory. Many of the blooms were very large and fine, and the colours fresh. The sorts were François Michelin, fine; Star of Waltham, fine; Baroness Rothschild, Duke of Edinburgh, Madame Eugene Verdier, John Brunner, Captain Christy, Charles Lefebvre, Countess of Rosebery, Marie Verdier, E. Y. Teas, Comtesse de Nadaillac, Gloire de Bourg la Reine, Catherine Mermet, Dr. Sewell, Magna Charta, Dupuy Jamain, Thérèse Levet, Niphetos, Duke of Teck, Madame Cusin, Prince Arthur, La Boule d'Or, Harrison Weir, Paul Neron, Mrs. C. Swait's, Marie Hausmann, Souvenir d'un Ami, Alfred Colomb, Henrich Schultheis, Rosieriste Jacobs, Auguste Rigotard, Prince Camille de Rohan, Madame H. Jamain, Penelope Mayo, Jean Ducher, Marie Rady, fine; Marie Finger, Fisher Holmes, Royal Standard, A. K. Williams, Souvenir de Paul Neyron, Marquise de Castellane, Madame Gabriel Luizet, Sir Garnet Wolseley, Madame Hippolyte Jamain, Antoine Ducher, Violette Bouyer. Mr. B. R. Cant was second with a stand in which were some good blooms. Notably so were Her Majesty, Merveille de Lyon, Queen of Queens, and Madame de Watteville. Messrs. Paul & Son, Cheshunt, Herts, third, with small but remarkably fresh blooms and of fine colour.

Thirty-six, distinct, three trusses of each. First £5, second £4, third £2.—Only three exhibitors staged for these prizes, the first going to Mr. B. R. Cant. The blooms being rather unequal in quality, some being rather passed though large, and others being rather small. The sorts were Pride of Waltham, Camille Bernardin, Merveille de Lyon, Abel Carrière, Souvenir d'un Ami, Star of Waltham, Madame Hippolyte Jamain, Abel Carrière, Ulrich Brunner, Comtesse de Nadaillac, Duke of Edinburgh, Queen of Queens, A. K. Williams, Madame de Watteville, La Boule d'Or, Prince Arthur, Maréchal Niel, Mons. E. Y. Teas, Lady Mary Fitzwilliam, Marie Van Houtte, Duke of Wellington, Her Majesty, Dr. Sewell, Souvenir d'Elise, Marie Rady, Comtesse Serenye, Madame Cusin, Madame Hippolyte Jamain, Innocente Pirola, Madame Charles Wood, Madame Caroline Kuster, Marie Baumann, Marguerite de St. Amand, and Fisher Holmes. Messrs. Paul and Son, Cheshunt, were a very close second, and Mr. Hugh Dickson, Belfast, third, with large blooms, rather lacking in colour and finish.

Twenty-four, distinct, single trusses, open only to nurserymen resident in Scotland. First prize a piece of plate, with £2 added, second £3, third £2.—Six of the Scottish nurserymen staged, and staged well in this class. The blooms were mostly large and full petalled, but wanting in the finish apparent in the English blooms. Messrs. James Cocker & Sons, Aberdeen, had the first prize awarded to their Rose, the whole of the blooms being fine and of a large and even size. The varieties included Magna Charta, Charles Lefebvre, Constantine Pretiakoff, François Michelin, Her Majesty, Comtesse d'Oxford, Baroness Rothschild, Alphonse Souper, Merveille de Lyon, Exposition de Brie, Madame Gabriel Luizet, Sénateur Vaisse, Lælia, Baron Hausmann, La France, Prince Camille de Rohan, Etienne Levet, Madame Victor Verdier, A. K. Williams, Marguerite de St. Amand, Marquise de Castellane, Duke of Edinburgh, Madame Hippolyte Jamain, and Mons. E. Y. Teas. Mr. W. Montgomery, The Glen Nursery, Cardross, second, with a lot scarcely inferior to the first, and third Mr. D. Robertsor, Mossend, Helensburgh, also good.

**Division B.**—The classes in this division were open only to the trade growers who did not compete in the corresponding classes in Division A. Class 4, thirty-six, distinct, single trusses, first £4, second £3, third £2.—Only three exhibitors staged for these prizes, and to Mr. John House, Eastgate Nursery, Peterborough, the first prize was awarded. The buds were rather small, but fresh, the most notable kinds represented being Francisca Kruger, Maréchal Niel, Catherine Mermet, and Niphetos. Messrs. J. Cranston & Co., Hereford, were second; and Mr. Frettingham, Beeston, Notts, third.

Class 5, eighteen, distinct, three trusses of each, first £3, second £2, third £1.—There were again three entries for these, Mr. House again being first, Merveille de Lyon, Catherine Mermet, and Jean Ducher being his most noteworthy blooms. Mr. Frettingham was second in this class, and Messrs. J. Cranston & Sons third.

#### TEA AND NOISETTE DIVISION.

The Teas, to judge by the limited number of exhibitors, one of the classes being without entries and the other only poorly filled, were not in good condition at time of show. The quality of the blooms shown left

further probability to this, as they were mostly small in size, though beautifully fresh and sweet.

Nurserymen.—Eighteen Teas or Noisettes, distinct, single trusses, first £2, second £1 10s., third £1.—Mr. Geo. Prince, Oxford, was in this class awarded the first prize, the blooms in his stand being rather heavier than those in the others. The sorts were—Cornelia Koch, Comtesse de Nadaillac, Etoile de Lyon, Catherine Mermet, Marie Guillot, Maréchal Niel, Hon. Edith Giffard, Souvenir d'un Ami, Souvenir d'Elise Vardon, The Bride, Princess of Wales, La Princesse Vera, Francisca Kruger, Innocente Pirola, Madame Cusin, Madame Margottin, Niphotos, and Marie Van Houtte. Second, Mr. B. R. Cant, with very fresh though small buds. Third, Messrs. Paul & Son, Cheshunt, Herts. There were six entries. No blooms were shown in the class for twelve sorts.

Amateurs.—Twelve Teas or Noisettes, distinct, single trusses, first £2, second £1 10s., third £1; first prize presented by Mr. George Prince, Oxford.—There were four entries for these, Mr. Thos. B. Hall, Rock Ferry, Cheshire, being first with not large but very fresh examples of Hon. Edith Giffard, Etoile de Lyon, Madame Cusin, Alba Rosa, Comtesse de Nadaillac, Anna Ollivier, Madame Margottin, Jean Ducher, Marcellin Rhoda, Francisca Kruger, Innocente Pirola, and Caroline Kuster. Second, Rev. J. H. Pemberton, Havering, Essex; and third, Mr. Thos. Farquharson, Broughty Ferry.

Six Teas or Noisettes, distinct, single trusses, first £1 10s., second £1, third 10s.—Six boxes were opened for the above, Lieut.-Col. F. S. Hore, St. Asaph, North Wales, being first with neat buds of Caroline Kuster, Hon. Edith Giffard, Jean Ducher, Madame Hippolyte Jamain, Madame Angèle Jacquier, and Comtesse de Nadaillac. Second, Mr. L. Garnett, Christleton Rectory, Chester; Mr. E. Mawley, Rosebank, Berkhamstead, being third.

Six Teas or Noisettes, distinct, single trusses, open only to amateurs resident in Scotland.—These were lacking in size as compared with the buds from England, Mr. Farquharson being first, Mr. Parlane second; and third, Rev. J. A. Paton, Castle Kennedy.

Twelve Teas or Noisettes, three trusses of each.—Rev. J. H. Pemberton was the only exhibitor of these, which were in many cases small, though perfectly fr. sb. The first prize was awarded for them.

#### AMATEURS' CLASSES.

The several classes in the division devoted to amateur growers were very well contested, and though many of the boxes were filled with blooms of inferior quality, the leading prizetakers and some others showed blooms good in size, of fine quality, and well up to the standard of the trade growers.

In the Jubilee class, twenty-four distinct, single trusses, open to all amateurs, the winner of the first prize to hold for the year a challenge trophy, value fifty guineas, and £3 in money; second, £3; third, £2; fourth, £1. The winner was T. B. Hall, Esq., Rock Ferry, Cheshire, who well won the trophy with fine blooms of John Stuart Mill, Lord Macaulay, A. K. Williams, Charles Lefebvre, Duc de Rohan, Madame Hippolyte Jamain, Mons. E. Y. Teas, Baroness Rothschild, Marie Rady, Alfred Colomb, Lord Bacon, Lady Mary Fitzwilliam, Julius Finger, Etienne Levet, Louis Van Houtte, Le Havre, Captain Christy, Thos. Mills, Marie Verdier, Fisher Holmes, Merveille de Lyon, Mrs. Laxton, Henri Ledechaux, and Comtesse de Camondo. Mr. E. R. Whitwell, Boston Hall, Darlington, was a very close second; third, Rev. J. H. Pemberton, Havering, Essex; and fourth, Mr. J. E. Backhouse, Croft, Darlington.

Division C.—Thirty-six distinct, single trusses. First prize a piece of plate presented by some amateur members of the Royal Caledonian Horticultural Society, with £4 added by the National Rose Society; second, £5; third, £3; fourth, £1. First, Rev. J. H. Pemberton, Havering, Essex, with Catherine Mermet, Alfred Colomb, Merveille de Lyon, Exposition de Brie, Innocente Pirola, Rosieriste Jacobs, Louis Van Houtte, Countess of Rosebery, Niphotos, Etienne Levet, Duke of Wellington, Captain Christy, Etoile de Lyon, Marie Baumann, Duchess of Bedford, Marie Finger, François Michelon, A. K. Williams, Camille Bernardin, Dr. Andry, Grandeur of Cheshunt, Caroline Kuster, Magna Charta, Abel Carrière, Harrison Weir, Lady Sheffield, Duke of Edinburgh, Souvenir de Paul Neyron, Eclair, La France, Pierre Notting, Pride of Waltham, Horace Vernet, Jean Ducher, Earl of Pembroke, and Ulrich Brunner. Second, Mr. C. R. Whitwell, and Mr. Hall third. These were the only exhibitors.

Twelve distinct, three trusses of each.—Prizes, first, £3; second, £2; third, £1. First, Mr. Hall, with Alfred Colomb, Etienne Levet, Duchesse de Caylins, Fisher Holmes, Baroness Rothschild, Merveille de Lyon, Duchesse de Vallombrosa, John Stuart Mill, Captain Christy, Marie Rady, La France, and Ulrich Brunner. The other prizes going to Mr. Whitwell and Rev. J. H. Pemberton in the order named.

Division D.—Exhibitors in this division were debarred from competing in that foregoing. In Class 8, twenty-four distinct, single trusses, £5, £4, £2, and £1. First Rev. L. Garnett, Christleton Rectory, Chester, with fine specimens of François Michelon, Heinrich Schultheis, Duke of Bedford, Mme. E. Verdier, Beauty of Waltham, Marie Verdier, Marquise de Castellane, Baroness Rothschild, Annie Wood, Charles Darwin, Emily Laxton, Captain Christy, Her Majesty, A. K. Williams, Prince Arthur, Duke of Wellington, Merveille de Lyon, Mdllc. Marie Rady, John Stuart Mill, Madame Prosper Laugier, Ulrich Brunner, Mrs. Laxton, Etienne Levet, and Madame Gabriel Luizet. Mr. W. Boys was the only other exhibitor, and to his Roses the second prize was awarded.

In Class 9, twelve distinct, single trusses, prizes £3, £2, £1, and 10s., seven exhibitors. First Mr. James E. Backhouse, Croft, Darlington, with Duke of Teck, Her Majesty, Marie Rady, Julia Dymonier, Marquise de Castellane, Madame Hippolyte Jamain, Madame Lacharme, Comtesse de Serenye, Dr. Andry, Madame Gabriel Luizet, Louis Van Houtte, and La France. Second Mr. Arthur Whitton, Askew, Bedale. Third Lieut.-Col. Hore.

In Class 10, six distinct, single trusses, four exhibitors. First, E. Mawley, Esq., Rose Bank, Berkhamstead, with Ulrich Brunner, Niphotos, Comtesse d'Oxford, Etienne Levet, Captain Christy, and Horace Vernet.

Division E, open only to amateurs resident in Scotland.—The Roses in the following classes were very decidedly inferior to those from the growers hailing from south the Tyne, the amateurs of Scotland in this respect falling much behind the Scottish nurserymen.

In Class 11, eighteen distinct, single trusses, the first prize, a piece of plate, value 7 guineas, presented by Messrs. Paul & Son, Cheshunt, Herts; second, £3; third, £2; eight exhibits. First Mr. A. Kirk, gardener to J. F. Paton, Esq., Norwood, Alloa, with Jean Liabaud, François Michelon, Charles Lefebvre, Beauty of Waltham, Alfred Colomb, Baroness Rothschild, Duke of Edinburgh, Madame E. Verdier, Marie Baumann, Comtesse d'Oxford, Marquise de Castellane, Mons. E. Y. Teas, La France, Sir Garnet Wolseley, Pride of Waltham, Xavier Olibo, and Etienne Levet. Second Mr. W. Parlane, Golfhill, and third Mr. T. Hogg, Cathcart.

In Class 12, twelve distinct, single trusses, twelve exhibits. First Mr. Thos. M'Corrie, Burnbrae Cottage, Kilbarchan, with Louis Van Houtte, Madame Gabriel Luizet, Senateur Vaisse, Pride of Waltham, Marie Baumann, Merveille de Lyon, Prosper Laugier, Madame Marie Verdier, A. K. Williams, Lady Mary Fitzwilliam, Charles Lefebvre, and Baroness Rothschild. Rev. J. A. Paton second, and Mr. John Kidd, Rothesay, third.

Class 13, six distinct, single trusses.—In this class Mr. John Thomson, Carron Flats, Grangemouth, was first with a nice lot of blooms, and Mr. G. Robertson, Naworth, Kelso, second.

Extra class, open to exhibitors in divisions C, D, and E, six new Roses, distinct, single trusses, for Roses offered for the first time in English nurserymen's lists in the spring of 1884 and subsequently. Mr. Wm. Boyes, Milford, Derby, was the only exhibitor in this class, showing medium flowers of Directeur Alpbard, Souvenir de Léon Gambetta, Gloire Lyonnaise, Grace Darling, Madame Dellavaux, and Eclair.

Open classes, the prizes in each case, £1, 15s., 10s. Class 21, twelve new Roses, distinct, single trusses. Messrs. Paul & Son, Cheshunt, Herts, were first with good blooms, comprising Princess de Beau, Comtesse F. de Bellay, Marshal P. Wilder, Her Majesty, Ella Gordon, Eclair, Madame Massieaut, Madame Miossett, Mary Benuett, Alphonse Souper, and General Appert. Second, Mr. B. R. Cant, the only other exhibitor.

Twelve single trusses of any yellow Rose. Mr. B. R. Cant was first with fairly good Maréchal Niels. Messrs. McGready & Son, Portadown, Ireland, second with same variety; and Mr. Hugh Dickson, Belfast, third, also with Maréchal Niel.

Twelve single trusses of any white Rose. Eleven competitors entered for this prize, Mr. Thos. Stranraer, receiving first with a very fine lot of Merveille de Lyon, large in size and spotless in purity. Mr. Hugh Dickson, a good second with same variety, and Mr. Cant, Colchester, third.

Twelve single trusses of any crimson Rose. First, Messrs. John Cranston & Co., King's Acre Nursery, Hereford, with A. K. Williams. Second, Mr. John House, Peterborough, with Fisher Holmes, and Messrs. Mack and Son with Marie Rady.

Twelve single trusses of any dark velvety crimson Rose. First, Mr. Hugh Dickson, with a good box of Horace Vernet. Second, Paul & Son, Cheshunt, Herts, with Abel Carrière, and third Mr. Cant with Reynolds Hole.

Twelve single trusses of any Rose. This was a strongly contested class, twelve exhibitors staging, and Messrs. Alex. Dickson & Sons, Newtonwards, Ireland, being first with very fine blooms of the Earl of Dufferin, large and good; Mr. James E. Backhouse, Croft, Darlington, second with Duchesse de Vallombrosa; and Mr. J. House, Eastgate Nursery, Peterborough, a good third with Queen of Queens.

Three trusses of any new seedling Rose, or distinct sport (not yet in commerce; a growing plant of the variety to be also shown), gold medal of the National Rose Society. This was awarded to Messrs. Robert Mack and Sons, Darlington, for Sir Rowland Hill, a velvety deep maroon variety somewhat shaded, and of a moderately full build. The habit of the plant is strong and healthy with good foliage. The silver medal for best Hybrid Perpetual was awarded to T. B. Halls, Esq., for a fine bloom of Louis Van Houtte; and Madame Willermoz shown by Mr. J. C. Day, Rowton, Cheshire, gained the medal for the best Tea Rose.

#### ROYAL CALEDONIAN SOCIETY'S CLASSES.

In connection with the ordinary summer Show of the Royal Caledonian Horticultural Society the following Jubilee prizes for Roses grown by gardeners and amateurs only, were offered—thirty-six Hybrid Perpetual Rose-blooms, not less than eighteen distinct varieties—a silver cup or piece of plate, presented by Mr. James Alexander, of Messrs. Dicksons & Co., nurserymen, Edinburgh, value £10 10s., for Scottish growers only. For this prize there were six entries, one or two of the lots being very good, Mr. A. Kirk, Norwood, Alloa, being fortunate in obtaining the cup with fresh blooms of the following varieties—viz., Etienne Levet, La France, Richard Wallace, Baroness Rothschild, Alfred Colomb, Mons. E. Y. Teas, Charles Lefebvre, Edouard Morren, Louis Van Houtte, Miss Ingram, Marguerite de St. Amand, Madame C. Joigneaux, François Michelon, George Dickson, Xavier Olibo, A. K. Williams, Marie Baumann, Emilie Hausburg, Ulrich Brunner, Miss Hassard, Jules Margottin, and Madame Laurent.

Thirty-six Rose blooms, distinct varieties—Prize presented by Messrs. John Lamont & Sons, nurserymen, Edinburgh, £3 3s.—In this class only two competitors came forward, the first prize going to Mr. James Walker, Clarendon, Lanlithgow, for the following varieties—Duchesse de Vallombrosa, François Michelon, Countess of Rosebery, Baroness Rothschild, Merveille de Lyon, Paul Neyron, Magna Charta, Madame Lacharme, Madame Gabriel Luizet, Etienne Levet, Marie Baumann, John Bright, La France, Ulrich Brunner, Countess of Oxford, Madame Eugene Verdier, Fisher Holmes, Souvenir d'Elise, Henry Pages, Duc de Montpensier, François Fontaine, Elie Morel, Madame Willermoz, Comtesse de Paris, Alfred Colomb, Helen Paul, Général Jacqueminot, Emilie Hausburg, Senateur Vaisse, White Baroness, Marquise de Castellane, Queen of Queens, Ulrich Brunner, Antoine Ducher, and Madame George Paul.

Twenty-four Rose blooms, distinct varieties—First and second prizes presented by Messrs. James Cocker & Sons, nurserymen, Aberdeen. First, £2 2s., second £1 1s., for Scottish growers only. In this class there was a keen competition, no fewer than eleven competitors staging. The general quality of the blooms was excellent. Mr. G. L. Hunter, Lauriston Castle, Midlothian, was first, and Mr. Parlane, Golfhill, a good second. The first prize lot contained the following kinds—Madame Nachury, Duchesse de Rambriaux, François Michelon, Etienne Levet, Senateur Vaisse, Alfred Colomb, Marquise de Castellane, Albert Pages, La France, Madame Gha-



Crapelet, Baroness Rothschild, Marie Rady, Marie Baumann, Maréchal Vaillant, John Hopper, Charles Lefehvre, Général Jacqueminot, Madame Thérèse Levet, La France, and Madame Hippolyte Jamain.

Twenty-four Rose blooms, distinct varieties—First and second prizes presented by Mr. Hugh Dickson, nurseryman, Belmont, Belfast. First £2 2s., second £1 1s., English growers excluded.—There was six entries in this class, Mr. A. R. Henderson, gardener to Mr. Macfie, Cleimiston, Corstorphine, being first, and Mr. W. Parlane second. Amongst the first prize lot were good blooms of Annie Laxton, François Michelin, Marie Finger, Magna Charta, Ulrich Brunner, Countess of Oxford, Thomas Mills, Marquise de Castellane, Princess Mary of Cambridge, Victor Verdier, A. K. Williams, Baroness Rothschild, Madame Isaac Periere, Pride of Waltham, Maréchal Vaillant, Lælia, Alfred Colomb, Madame Nachury, Xavier Oliho, Star of Waltham, Dupuy Jamain, La France, Sénateur Vaisse, and Marquise de Mortemart.

Twelve Roses, distinct varieties, three blooms of each. First and second prizes presented by Mr. Thomas Smith, nurseryman, Stranraer. First prize, £2 2s.; second prize, £1 1s., for Scottish growers only. Three competitors staged. Mr. Henderson was placed first with very fresh blooms, and Mr. P. McTavish, Airthry Castle, Stirling, second. The first lot comprised the following sorts—viz., Louis Van Houtte, Baroness Rothschild, Victor Verdier, Peach Blossom, Annie Laxton, Comte de Raimbaud, Madame Hippolyte Jamain, François Michelin, Xavier Oliho, Etienne Levet, and La France.

Twelve Tea, and twelve Hybrid Perpetual Rose blooms, distinct varieties. Prize presented by Messrs. R. B. Laird & Sons, nurserymen, Edinburgh. For this prize there was only one entry, Mr. Parlane staging fresh blooms of the following varieties—Clara Cochet, Gloire de Dijon, Souvenir d'un Ami, Perle des Jardins, Catherine Mermet, Alba Rosea, Niphetos, Rubens, Marie Van Houtte, Baroness Rothschild, Edouard Morren, La France, A. K. Williams, Duchesse de Vallambrosa, Alfred Colomb, and Hippolyte Jamain, Horace Vernet, Captain Christy, Marie Baumann, Reine du Midi, and Beauty of Waltham.

Twelve blooms of the old Cabbage Rose. A flower stand presented by Mr. A. Jenkinson, merchant, 10, Princes Street, Edinburgh, value £1 5s. There were four entries for this prize, Mr. W. Chapman, Grangemouth, being first with fairly good blooms.

Three bouquets of Roses. First prize presented by Mr. John Grieve, of Midfield, Waterloo Hotel, Edinburgh, £2 2s. Second prize presented by Mr. David Mitchell, Comely Bank, Edinburgh, £1 1s. Of these the only ones that were really noteworthy were those set up by Miss Watson, 56, Albert Street, and to which the first prize was awarded. One was composed of yellow buds neatly and lightly arranged; another of white and light blush sorts, and the third of maroon and yellow Roses. These were really beautiful examples of bouquet making. Mr. Bald, Canada Lane, second.

Messrs. W. Paul & Son, Waltham Cross, N., exhibited twenty-four boxes and twenty-four baskets of Teas and H.P.'s in varieties, each containing about fifty blooms. Mr. Jas. Bryson, Helensburgh, put up a hamper full of blooms of old fashioned and "other" Roses, among which were the York and Lancaster, Aimée Vibert, Charles Lawson, Madame Plantier, Madame Hardy, and other varieties which are not nearly so much grown as their merit entitles them to be.

#### OXFORD.—JULY 12TH.

No more pleasant site in or around Oxford could well be suggested for holding this Society's Exhibition than the gardens of Worcester College, and it would be difficult to name one more suited to the convenience of everyone concerned. Situated near the railway stations at the west end of Beaumont Street, and readily accessible from all parts of the city, the gardens have acquired the fame of being amongst those of the most beautiful in Oxford. The mention of Beaumont Street recalls to mind the palace that formerly existed bearing the same name, the residence of Edward II., who frequently visited the city, and in which the lion-hearted Richard I. and John were born, the latter of whom executed the famous deed at Runnymede, the title of which distinguishes one of the most highly esteemed H.P. Roses that in recent years has graced both our gardens and exhibition stands.

Approaching from the piazza and passing through the large quadrangle, the west side of which is festooned from one end to the other with *Wistaria sinensis*, a short, arched passage leads to the garden in which this Society is holding its thirty-sixth Exhibition. So well was "future effect" studied when this garden was originally planted that its extent from any one spot cannot now be judged. On the central lawn, more especially, there are some fine trees that are deserving of notice. Three exceedingly fine *Ailantus glandulosa* bearing myriads of flower buds occupy what may be represented as the angles of an unequal sided triangle, on the shortest side of which there is a picturesque group of trees filling an oval of somewhat irregular outline, surrounded by a marginal line of Willow-weed, &c., which is more or less overhung with old fashioned Roses, flowering Thorns and Currants, Syringas, Laburnums, and large tree Box; above these rise large specimen Pines and lofty Lomhardy Poplars. Within this arrangement, or nearly so, are fine trees of Purple Beech, Silver Birch, an aged Mulberry with branches extending over a space of nearly 40 feet, an Acacia, Tulip Tree, Spanish Chestnuts and Walnuts. There are many other noteworthy trees here, the largest of them being English Elms and Horse Chestnuts, and it is under the shade of some of these a marquee, 140 feet long and 40 feet wide, had been erected to stage one of this Society's most satisfactory displays of the Queen of Flowers. The lake at the lower end is a feature of the garden, and if evidence were wanted of what here so much impresses one with a sense of sweet seclusion, it is there in the nearest Chestnut tree, in the shape of a wood pigeon sitting on her nest. But while these notes were being jotted down the rosarians were busily engaged arranging their stands, and their achievements have to be chronicled in the Journal.

In the division open to all England, in class 1, for forty-eight varieties, three trusses of each, there were four entries, and the leading position was taken by Mr. Charles Turner, Slough, with a well-arranged stand of fresh-looking blooms, the most noteworthy of them being Alfred Colomb, Lord Macanlay, Marie Baumann, Abel Carrière, Mons. E. Y. Teas, Duke of Connaught, Charles Darwin, Penelope Mayo, Devienne Lamy, Madame Victor

Verdier, Harrison Weir, Avocat Duvivier, Reynolds Hole, Pierre Notting, Xavier Oliho, Star of Waltham, Ulrich Brunner, Etienne Levet, François Michelin, Georges Moreau, Pride of Waltham, Royal Standard, Magna Charta, Baroness Rothschild, Her Majesty, Mdlle. Marguerite Dombrain, Madame Marie Verdier, Elie Morel, La Duchesse de Morny, Captain Christy, Comtesse de Serenye, Lady Mary Fitzwilliam, Sunset, The Bride, Caroline Kuster, Innocente Pirola, and Madame Margottin. The second prize was won by Mr. John Mattock, New Headington, Oxford, with a fine stand of blooms, hut smaller than those of the above, the finest of them being Dr. Andry, Mdlle. Marie Rady, Abel Carrière, Duke of Edinburgh, Alfred Colomb, Marie Baumann, Star of Waltham, Ulrich Brunner, Queen of Queens, Madame Sophie Fropot, Marquise de Castellane, Mdlle. Marie Cointet, Elie Morel, Comtesse de Serenye, Lady Mary Keith, Merveille de Lyon, Madame de Watteville, Niphetos, Bellefleur d'Anjou, Madame Hippolyte Jamain, Innocente Pirola, Marie Van Houtte, Bouquet d'Or, and Souvenir d'un Ami. The third prize was taken by Messrs. Geo. Cooling & Son, Bath.

In class 2, for forty-eight single trusses, Mr. Charles Turner again secured the premier position, many of his most noteworthy blooms being those of the varieties mentioned in the former class, but there were in addition good examples of Louis Van Houtte, Madame Eugénie Verdier, John Hopper, Longfellow, Horace Vernet, Auguste Rigotard, and Comtesse de Nadaillac. Messrs. George Cooling & Son were second and Mr. John Mattock third. In class 3, for thirty-six varieties, Mr. John Mattock was placed first with an excellent stand; omitting mention of the kinds enumerated in his exhibit in class 1, there were those of Duchess of Bedford, Madame Victor Verdier, Pierre Notting, Charles Lefehvre, Jean Liahaut, Madame Ducher, Mdlle. Annie Wood, Sénateur Vaisse, Mons. Alfred Dumesnil, Etienne Levet, Captain Christy, Madame Gabriel Luizet, Madame Eugénie Verdier, Baroness Rothschild, Her Majesty, Etoile de Lyon, Maréchal Niel, and Jean Ducher. The second and third prizes were taken by Mr. C. Turner and Mr. William Rumsey, Waltham Cross, in the order named.

In class 4, for twenty-four varieties, Mr. John Walker, Thame, secured the first position in the face of keen competition, the undermentioned blooms in this stand being particularly fine—namely, Auguste Mie, Reynolds Hole, Mons. E. Y. Teas, Marie Baumann, A. K. Williams, Charles Lefehvre, Duke of Wellington, Duchesse de Caylus, Edouard Morren, Dupuy Jamain, Auguste Rigotard, Merveille de Lyon, and Maréchal Niel. The second and third prizes were awarded exactly as in the previous class. In class 5, for twelve trusses of one variety, dark H.P., Mr. W. J. Grant, Ledbury, gained first honours with a beautiful stand of Abel Carrière; Messrs. George Cooling & Son were second with A. K. Williams, and S. P. Budd, Esq., Bath, was third with Marie Baumann. In class 6, for the same number of a light variety, only two stands were staged, both of them Merveille de Lyon, Mr. William Rumsey being placed first, and Mr. A. Evans, Marston, Oxford, second.

In class 7, for twelve varieties, Tea or Noisette, Mr. John Mattock, staged a charming stand, taking the premier position with Bougère, Catherine Mermet, Etoile de Lyon, Innocente Pirola, Jean Ducher, Madame de Watteville, Madame Cusin, Madame Hippolyte Jamain, Marie Van Houtte, Perle des Jardins, Pauline Labountz, and a superb bloom of Souvenir d'un Ami. Mr. George Humphrys, Kingston Langley, Chippenham, was second, and Mr. William Rumsey was third.

In the division open to all, except growers for sale, in class 8, for thirty-six varieties, Mr. W. J. Grant was first with a superb stand of blooms which, in addition, won the National Rose Society's gold medal for the best stand of Roses exhibited in the open classes. It is unnecessary to recapitulate the names of the blooms, the whole of them maintaining the high order of merit of those exhibited by this successful rosarian at kindred meetings during the present season. The other prize-winning stands, too, contained some exceptionally good flowers, and were staged by S. P. Budd, Esq., and T. W. Girdlestone, Esq., Sunningdale, who were placed in the order named. In class 9, for twenty-four varieties, E. B. Lindsell Esq., Bearton, Hitchin, was to the fore with a very fresh-looking, well-arranged stand, all of which have already been mentioned in other exhibits, but those of Lady Mary Fitzwilliam, Comtesse de Nadaillac, Ulrich Brunner, and Her Majesty were especially noteworthy. The second prize fell to T. W. Girdlestone, Esq., whose stand contained a highly coloured Maréchal Niel, and beautiful blooms of Etoile de Lyon and Souvenir d'Elise Vardon, W. J. Grant, Esq., being third. In Class 10, for twelve varieties, J. B. Ward, Esq., M.D., Warnetord Asylum, Oxford, was awarded the first prize for a good stand of blooms, but there was no other competitor. In class 11, for twelve varieties, Tea or Noisette, W. J. Grant, Esq., was first; T. W. Girdlestone, Esq., second; and E. B. Lindsell, Esq., third.

In the division for amateurs (members of the society only), in class 12, for eighteen varieties, an excellent stand from Mr. Wm. Narrowway secured both the premier position and the silver gilt medal of the National Rose Society for the best stand in this division. The second prize was taken by Mr. A. Evans, Marston, Oxford, from whose stand the Judges selected the best H.P. bloom (Mdlle. Marie Rady), for the distinction of being awarded the silver medal of the aforementioned Society. The third prize went to Mr. Charles Taylor, Headington. In class 13, for twelve varieties, R. E. West, Esq., Wray Park, Reigate, in whose stand dark Roses predominated, amongst them being a very fine bloom of Xavier Oliho, easily secured the first award; Mr. Arthur Stow, Headington, was second; Mr. James Colcutt, Oxford, third, and R. Ramsden, Esq., fourth. In class 14, for nine varieties, Mr. A. Stow was first, Mr. F. Freeman, Oxford, second, Mr. J. Colcutt third, and the Rev. H. A. Pickard, Oxford, fourth. In class 15, for twelve triplets, the first prize went to Mr. A. Evans, and the second to the Rev. C. Eddy, Bramley, Basingstoke. In class 16, for six triplets, R. Ramsden, Esq., Chadwick Manor, Knowle, and Mr. Hy. Poulter, Oxford, were respectively placed first and second. In class 17, for six trusses of one H.P. variety, R. E. West, Esq., was first with Alfred Colomb; Mr. Wm. Narrowway, second with Mdlle. Marie Rady, and Mr. A. Evans with Baroness Rothschild. In class 18, for six Tea or Noisette blooms, R. Ramsden, Esq., was first, and it was a specimen of Maréchal Niel in this exhibit that gained the silver medal of the National Rose Society. Mr. A. Evans was second, and the Rev. H. A. Pickard, third. For a single bloom, H.P., Mr. Narrowway was first with Mdlle. Marie Rady; Mr. A. Evans second with Hippolyte Jamain, and Mr. H. Stow third. For a single bloom of Tea



or Noisette, Mr. A. Evans was first with Etoile de Lyon, the Rev. R. G. Downes second with Maréchal Niel, and Mr. Wm. Narroway third. The two first medals that have been mentioned were presented by the President of the Society, G. Herbert Morrell, Esq.

#### HITCHIN.

If the "stars in their courses" did not fight against the promoters and well-wishers of this Show the sun in his strength did, and, as many of its supporters are small growers, the hot weather told more severely upon them than upon large growers, who can probably put their plants in various positions, and so manage to secure blooms in one place or the other; this same reason doubtless hindered several of the larger growers for sale from competing, and thus the extent of the Show was lessened.

The Exhibition was held in a tent in the grounds of J. Delmé Ratcliffe, Esq., a place very well adapted for the purpose close to the town, and with pleasant surroundings of trees and water, and there was much energy and courtesy displayed by our excellent friend the Rev. F. H. Gall and the members of the Committee, while as it was held at Hitchin it was but natural to suppose that Mr. E. B. Lindsell, who has exhibited in such good form this year, would show some excellent flowers, and in truth it would be hard to excel even in the most favourable season the stand of twenty-four with which he gained the first prize. Mr. Gall, too, showed better than I have seen him exhibit before.

In the nurserymen's class for forty-eight blooms, distinct, the first prize was awarded to Mr. Merryweather of Southwell for Captain Christy, Dr. Andry, Madame Marie Finger, Marie Baumann, Catherine Soupert, Charles Lefebvre, Hon. Edith Giffard, Marie Verdier, Niphetos, Comte Raimbaud, A. K. Williams, Mary Bennett, Madame de Watteville, Le Havre, Madame Lacharme, Prince Arthur, Reynolds Hole, La France, Général Jacqueminot, Crown Prince, Egeria, Princess Mary of Cambridge, Etienne Levet, François Michelin, Madame Charles Wood, Lady Mary Fitzwilliam, Marie Rady, Victor Verdier, Ulrich Brunner, Violette Bouyer, Catherine Mermet, Duke of Wellington, Marquise de Castellane, Her Majesty, Fisher Holmes, Marguerite de St. Amand, Madame Clemeuce Joigneaux, Madame Hippolyte Jamain, Madame Eugène Verdier, Baroness Rothschild, Sultan of Zanzibar, Annie Laxton, Camille Bernardin, Madame Gabriel Luizet, and Louis Van Houtte. Messrs. Burrell & Co. were second with good blooms, La France being especially fine, and Messrs. Burch & Sons of Colchester third.

In the class for eighteen Teas (open) Messrs. Burrell & Co. of Cambridge, were first with Madame de Watteville, Maréchal Niel, Niphetos, Princess of Wales, La Boule d'Or, Madame Bravy, Madame Angèle Jacquier, Catherine Mermet, Rubens, Innocente Pirola, Comtesse de Nadaillac, Madame Margottin, Madame Lambard, Jean Ducher, The Bride, Francisca Kruger, David Pradel, and Madame Welch. The Rev. W. H. Jackson of Stagsden Vicarage, Bedford, was second.

In the class for amateurs, twenty-four varieties, Mr. E. B. Lindsell was a long way first with a beautiful box of blooms of Xavier Olibo, Ulrich Brunner, Duchess of Vallambrosa, Marie Rady, Abel Carrière, Lady Mary Fitzwilliam, this very fine flower gained the National Rose Society's Silver medal for the best H.P. in the Show; Prince Arthur, François Michelin, Dr. Andry, Madame Gabriel Luizet, Charles Lefebvre, Innocente Pirola, Merveille de Lyon, Horace Vernet, Maréchal Niel, Marie Baumann, Marie Cointet, Sultan of Zanzibar, La France, Victor Hugo, Mons. Noman, Comtesse de Nadaillac, this bloom gained the National Rose Society's silver medal for the best Tea or Noisette in the amateurs' classes; Dr. Sewell, and Baroness Rothschild. The Rev. W. H. Jackson was again second in the class for twelve trebles. Mr. Lindsell was again first with a box of beautifully finished blooms, consisting of Captain Christy, Abel Carrière, Marie Baumann, Mons. Noman, Madame Gabriel Luizet, A. K. Williams, Horace Vernet, Merveille de Lyon, Ulrich Brunner, Maréchal Niel, Innocente Pirola, and La France. In class 5, for twelve distinct, Mr. G. Moules, Hitchin, was first, Ulrich Brunner, Baroness Rothschild, Senateur Vaisee, Lady Mary Fitzwilliam, Madame G. Luizet, Camille Bernardin, Devoniensis, Marquise de Castellane, Reynolds Hole, Niphetos, Marie Rady, and Anna Ollivier. Mr. R. E. West of Reigate was second, and the Rev. F. H. Gall third. In the class for four trebles Mr. R. E. West was first with Abel Carrière, Baroness Rothschild, Ulrich Brunner, and Captain Christy. The Rev. F. H. Gall was second with very good blooms, and the Rev. Fox Lambert third. In classes for nine distinct trusses, Miss A. M. Lucas was first with Marguerite Brassac, La France, Duke of Wellington, Duchess of Bedford, Marie Finger, Etienne Levet, Captain Christy, and Marie Baumann. Mrs. Tomes was an equal first with La France, Captain Christy, Duke of Edinburgh, Caroline Kuster, Madame G. Luizet, Madame Lacharme, Mons. Noman, and Mrs. Baker. In class 9, for twelve Teas and Noisettes, E. B. Lindsell, Esq., was first with Innocente Pirola, Maréchal Niel, Niphetos, Comtesse de Nadaillac, Jean Ducher, Souvenir d'un Ami, Etoile de Lyon, Madame Cusin, Caroline Kuster, Madame Angèle Jacquier, Catherine Mermet, and Hon. Edith Giffard. The Rev. W. H. Jackson was second. In Class 10, six Teas or Noisettes, the Rev. F. Lambert was first with Maréchal Niel, Hon. E. Giffard, Madame Lambard, Innocente Pirola, Marie Van Houtte, and Caroline Kuster. In Class 11, six trebles, Teas or Noisettes, E. B. Lindsell was first with Maréchal Niel, Niphetos, Catherine Mermet, Madame Willermoz, Caroline Kuster, and Innocente Pirola. In the Jubilee class for eighteen blooms, twelve H.P.'s and six Teas, not necessarily distinct, Mr. B. Lindsell was again first with Merveille de Lyon, Ulrich Brunner, Innocente Pirola, and Comtesse de Nadaillac.

The Rev. F. H. Gall, who has taken so deep an interest in the Hitchin Show, entertained the Judges and exhibitors at luncheon at the "Sun Hotel," in his usual spirit of kind and genial hospitality, to which also Mr. Atherton sent some of his most excellent Strawberry All Round, the finest fruits I had seen this year.—D., Deal.

#### BIRMINGHAM.

For a number of years the Birmingham Rose Show took its place amongst the foremost of our Rose gatherings, but it is now several years since that the Society held its last meeting in the Town Hall. Efforts have been made to revive these gatherings at various places about Birmingham; but it was not until the meeting of the National Rose Society in the Botanical Gardens last year that a good Rose show was again seen in the Midlands. This year the Council of the Botanical Society deter-

mined on holding an exhibition of Roses on their own account, and this took place on the 14th and 15th inst. The claims upon our great growers in the Rose season render it impossible for many to attend every exhibition, and the rigid rule of the National Society against two-day exhibitions must not be overlooked, and then there was the intensely hot dry weather throughout July, all of which tended to reduce the number of exhibitors, and consequently the display. Notwithstanding these drawbacks there was a good display of blooms.

In the open class for nurserymen Messrs. Harkness & Sons of Bedale won the leading honours, and even with greater competition would have been able to hold their position, although they had one formidable opponent in Mr. Merryweather of Southwell, both growers showing in exceedingly good form. In the class for forty-eight blooms, singles, first Messrs. Harkness & Son with Marie Finger, Dr. Andry, Paul Neyron, Antoine Ducher (fine), Merveille de Lyon, and Etienne Levet (both fine blooms), Marie Verdier, Star of Waltham, Madame Sophie Fropot, A. K. Williams, Lord Beaconsfield, Mons. Noman, E. Y. Teas, Marquise de Castellane, Princess Beatrice, François Michelin. Second row: Henrich Schultheis, Duchesse de Vallombrosa, Charles Lefebvre, Duchesse de Morny, Captain Christy, Sir Garnet Wolseley, Magna Charta, Madame Hausmann, Duke of Edinburgh, Edouard Morren, Alfred Colomb, Baronne de Rothschild, Ulrich Brunner, Queen of Queens, Marie Rady. Third row: Dr. Hogg, Catherine Mermet, a fine bloom of Harrison Weir, La Boule d'Or, Madame Cusin, Marie Baumann, La France, Reynolds Hole (a grand bloom with a beautiful bright velvety tint upon it), Caroline Kuster, Le Havre, Prince Arthur, Niphetos, Henri Ledechaux, Violette Bouyer, Pierre Notting, and Tea Madame de Watteville. Second Messrs. Perkins & Son, Coventry, having Duchess of Bedford, A. K. Williams, Pride of Waltham, and Duchesse de Rohau, very good.

In the class for twenty-four trebles Messrs. Harkness & Son were first with excellent blooms of Madame Hausmann, Baroness Rothschild, Horace Vernet, Queen of Queens, E. Y. Teas, Duchesse de Vallambrosa, Etienne Levet, La France, Fisher Holmes, Madame Gabriel Luizet, Ulrich Brunner, La Boule d'Or, Innocente Pirola, Marie Rady, Souvenir d'un Ami, François Michelin, Niphetos, Marquise de Castellane, Violette Bouyer, A. K. Williams, Lady Mary Fitzwilliam, Alfred Colomb, Merveille de Lyon, and Le Havre. Mr. Merryweather, Southwell, with an excellent second, including very fine blooms of Comtesse de Nadaillac, Capt. Christy, Her Majesty, very fine indeed; and Maréchal Niel, well coloured. Third, Messrs. Perkins & Sons, Coventry.

In the class for twenty-four singles Mr. Merryweather was first with Marie Baumann, Her Majesty, A. K. Williams, Baroness Rothschild, Mrs. Charles Wood, Madame Gabriel Luizet, Countess of Oxford, Helen Paul, very fine indeed; Lady Mary Fitzwilliam, Marie Rady, Marquise de Castellane, Star of Waltham, a grand richly coloured Maréchal Niel (also exhibited at Bedford the day previous), Fisher Holmes, very fine; Elie Morel, and Madame Eugénie Verdier, Duchess of Bedford, Violette Bouyer, Camille Bernardin, Marquise de St. Amand, Dupuy Jamain, Prince of Wales, Harrison Weir, very bright; and Egerie. Second, Messrs. Harkness & Sons; Ulrich Brunner, Horace Vernet, E. Y. Teas, and A. K. Williams being very fine. Third, Messrs. Perkins & Sons. In the class for twelve Tea and Noisettes (open), first, Messrs. Harkness & Sons with Caroline Kuster, Thérèse Levet, Hippolyte Jamain, Souvenir de Paul Neyron, Madame de Watteville, Innocente Pirola, Souvenir d'un Ami, Madame Berard, Niphetos, La Boule d'Or, Comtesse de Nadaillac, and Madame Cusin. Second, Mr. Merryweather.

The following classes were for amateurs and gentlemen's gardeners: For thirty-six Roses, singles, distinct, first, the Veitch Memorial prize of £5 and medal, W. J. Grant, Esq., Hope End Farm, Ledbury, with Louis Van Houtte (a splendid bloom), Etienne Levet, Prince Arthur, Captain Christy, Star of Waltham, La France, Horace Vernet, Marie Baumann, Sir Garnet Wolseley, Alfred Colomb, Marquise de St. Amand, Pride of Waltham, Mons. Wolfeld, Duke of Teck, Souvenir d'Elise Vardon (fine), A. K. Williams, Merveille de Lyon, Reynolds Hole (very fine), Souvenir d'un Ami, Charles Darwin (very fine), Comtesse de Nadaillac. Dr. Andry, Marie Verdier, Ulrich Brunner, Marie Rady, Marie Van Houtte, Lady Sheffield (fine), Innocente Pirola, Madame Charles Crapelet, Catherine Mermet, La Rosière, Niphetos, Abel Carrière, Fanny Olivier, a beautiful bloom of Pierre Notting, and Francisca Kruger, one of our finest Teas. Second William Boyes, Esq., Milford, Derby.

For twenty-four single blooms, distinct, first Mr. W. J. Grant with Star of Waltham, La France, Prince Camille de Rohan, Merveille de Lyon, Horace Vernet, Captain Christy, Alfred Colomb, Pride of Waltham, Marie Verdier and Charles Darwin (both fine), Maréchal Niel, A. K. Williams; Catherine Mermet, Dr. Andry, Etoile de Lyon (fine in its yellow colour); Madame Victor Verdier, Duke of Teck, Marguerite de St. Amand, Fisher Holmes, Tea Rubens, Thomas Mills, Comtesse de Nadaillac (a beautiful bloom), Abel Carrière, and Marie Van Houtte—a fine stand. Second A. H. Griffiths, Esq., Edgbaston (Mr. Booker, gardener), with a good stand, which included fine blooms of Star of Waltham, Paul Neyron, Marguerite Brassac, and François Michelin. Third Mr. Whittle, Belgrave, Leicester.

In the class for twelve trebles Mr. Grant was again first with La Boule d'Or, Madame Victor Verdier, Souvenir d'un Ami, Charles Lefebvre, Captain Christy, Marie Baumann, E. Y. Teas, Etienne Levet, Pierre Notting, La France, Général Jacqueminot, and Madame Hippolyte Jamain. There were no other exhibitors in this class. For twelve single blooms, distinct, first Mr. W. J. Grant with Charles Darwin, Madame Gabriel Luizet, Marie Rady, Souvenir d'Elise Vardon, Marie Verdier, A. K. Williams, La Boule d'Or, Horace Vernet, Prince Arthur, Caroline Kuster, Abel Carrière, and Alfred Colomb. Second, Mr. Wm. Boyes. Third, Rev. Dr. Watson, Birkswell, near Coventry. For twelve Teas or Noisettes, distinct, first Mr. W. J. Grant, with Catherine Mermet, Caroline Kuster, Princess of Wales (fine), Perle de Lyon, Innocente Pirola, Miss Edith Giffard, Madame Margottin, a grand bloom of La Boule d'Or in form, but with colour gone; Madame Cusin, Francisca Kruger, Souvenir de Paul Neyron, and Marie Van Houtte. Second Mr. William Boyes; third R. Ramsden, Esq., Knowle, near Birmingham.

The classes for twenty-four Roses, single blooms, and twelve for twelve single blooms were confined to amateurs and gentlemen's gardeners residing within four miles of the Birmingham Town Hall, and in those two

classes were several good exhibits, the winning stands especially. For twenty-four Mr. A. H. Griffiths was first with Star of Waltham, Duchesse de Vallambrosa, Marie Baumann, Merveille de Lyon, Horace Vernet, Mad. Hippolyte Jamain, Mrs. Laxton, Comtesse de Serenye, Paul Neyron Miss Hassard, Abel Carrière, Marquise de Castellane, Marie Verdier, Charles Lefebvre, François Michelin, Louis Peyronny, Alfred Colomb, Ulrich Brunner, Duke of Teck, Madame Gabriel Luizet, Magna Charta, A. K. Williams, Queen of Queens, and Pierre Notting. Second, W. C. B. Cane, Esq., Harborne, with good blooms. Third, J. E. Wilson, Esq., Wyddrington, Birmingham. For twelve blooms Mr. Griffiths was again first with bright even blooms, and J. Richards, Esq., Edgbaston, second. Third, G. H. Kenrick, Esq. In the class for twelve white Roses, any sort, Merveille de Lyon took the lead. Messrs. Harkness & Son first, Messrs. Perkins & Son second and Mr. Whittle third. For twelve crimson, any one sort, first Mr. Griffiths, with a fine stand of Star of Waltham. Second, Messrs. Perkins & Son with Charles Lefebvre. Third, Messrs. Harkness and Sons.

Amongst miscellaneous exhibits Messrs. John Laing & Co., Forest Hill Nurseries, obtained a first-class certificate for fine cut blooms of double and single Tuberos Begonias. Messrs. Hans Niemand & Co., the same honour for a handsome group of plants, and Mr. R. H. Vertegans for cut herbaceous blooms and alpine plants, and first-class certificates for two charming seedling varieties of Campanula trachelium, named Chad Valley Gem and Distinction. Messrs. Perkins & Sons, Coventry, took the first prize for a very handsome bouquet of Roses, and Mr. Latham, Curator of the Botanic Gardens, added to the beauty of the Rose Show by using Palms, Ferns, &c. Messrs. Williams, Brothers, Birmingham, were awarded certificates for a combined syringe and tank with india-rubber hose, a boon to amateurs; also for a simple but excellent flower support with spring clasp, suitable for Pinks, Carnations, and Picotees, Auriculas, Hyacinths, and many things, a very welcome acquisition to our garden sundries.

#### HEREFORD AND WEST OF ENGLAND.

THE twenty-first annual Exhibition of Roses at Hereford was held in the Shire Hall on Friday, 15th inst., and although the fixture was unavoidably a late one for Hereford, the Show was a marked success as far as the quantity and quality of Roses staged could insure success.

The nurserymen's classes were all well contested by Messrs. Harkness Bros., B. R. Cant, Geo. Paul & Son, Keynes, Williams & Co., Cooling & Son, Cranston & Co., &c., and much interest was evinced as to whether the now famous young firm from Yorkshire would maintain the success they had already achieved this season at South Kensington, Bath, Edinburgh, and Birmingham, as it was at Hereford last year that they gained their first seventy-two. The contest between the northern growers and Mr. B. R. Cant was a sharp one, both showing in excellent style; Messrs. Harkness Bros., however, were first with one of the brightest and best seventy-tvos we have seen this season, their flowers were much larger than those exhibited by them at South Kensington, and were remarkable for their quality and brilliant colour, consisting of the following varieties—Marie Finger, Marie Baumann, Captain Christy, Madame E. Verdier, Ulrich Brunner (very fine), Mrs. Caroline Swailes, Lord Macaulay, Magna Charta, Madame Victor Verdier, Merveille de Lyon, Maurice Bernardin, Lady Mary Fitzwilliam, May Quennel, Marie Verdier, Marie Rady, Mons. Noman, Etienne Levet (grand), Marquise de Castellane, Madame Hausmann, Baroness Rothschild, Horace Vernet, Queen of Queens, François Michelin, Alfred Colomb, Duke of Albany, La France, Antoine Ducher, Dupuy Jamain, Jean Ducher, John Bright, La Duchesse de Morny, Hippolyte Jamain, Comtesse de Serenye, Général Jacqueminot, Marie Van Houtte, Dr. Andry (very beautiful), Catherine Mermet, E. Y. Teas, Niphotos, Abel Carrière, Louis Van Houtte, Lady Sheffield, La Rosière, Madame Lacharme, Reynolds Hole, Violette Bouyer, Beauty of Waltham, Prince Arthur, Comtesse de Nadaillac, Gloire de Bourg la Reine, Duke of Teck, Fisher Holmes, Chas. Darwin, Innocente Pirola, Sultan of Zanzibar, Emilie Hausberg, Duchess of Bedford, Auguste Rigotard, Jean Liabaud. Mr. B. R. Cant was second with excellent blooms, amongst which we noticed a large number of fine Teas, Madame Cusin, Madame A. Jacquier, and Maréchal Niel being particularly good. Messrs. George Paul & Son third. An extra prize was awarded to Messrs. Keynes, Williams & Co., Salisbury. Five entries in this class.

For thirty-six varieties, three trusses each, Messrs. B. R. Cant, Paul, Keynes, Williams & Co. were the prizewinners in the order named. In Mr. Cant's triplets we noticed Madame de Watteville, Lady Mary Fitzwilliam, Madame Cusin, Maréchal Niel, Pierre Notting, A. K. Williams, Innocente Pirola, Auguste Rigotard in very fine condition. The premier place for forty-eight single trusses, distinct, was taken by Messrs. Cranston & Co., Hereford, with magnificent blooms of good colour and fine form, Countess of Oxford, Barthelemy Joubert, Duke of Albany, Abel Grand, Innocente Pirola, and Marie Cointet being the most remarkable; Messrs. Cooling & Son of Bath were a good second; Mr. Whiting, Hereford, third. In the class for twenty-four varieties, three trusses each, Messrs. Cooling were well ahead with a very even fresh lot of compact blooms; Messrs. Cranston second; Messrs. Griffiths & Son, Tillington Nursery, Hereford, third. Twenty-four varieties, single trusses, is always a popular class at Hereford, and on this occasion there was no exception to the general rule, all the exhibitors staging in fine condition. Messrs. Cranston again took the lead, followed by Messrs. Griffiths & Son and Mr. C. Whiting, all of them showing well.

In the amateurs' division B, open to the United Kingdom, the competition lay between Mr. W. J. Grant, Hope End Farm, Ledbury, and Mr. Budd, Bath. The award for thirty-six distinct varieties, single trusses, with the silver medal of the National Rose Society, was made in favour of Mr. Grant, who staged large well-finished fresh blooms of Charles Lefebvre, Marie Verdier, Souvenir de Thérèse Levet, Comtesse d'Oxford, Marie Baumann, Etienne Levet, Star of Waltham, Souvenir d'un Ami, Xavier Oibo, Souvenir d'Elise, Horace Vernet, La Boule d'Or, Alfred Colomb, Souvenir de Paul Neyron, Charles Darwin, Pierre Notting, La Rosière, sort from Marie Van Houtte, Benoit Comte, Catherine Mermet, Fisher Holmes, La France, Prince Arthur, La Duchesse de Morny, Duke of Teck, Madame Margottin, Général Jacqueminot, Madame G. Luizet, Louis Van Houtte (fine), Marguerite de St. Amand, Madame Victor Verdier, Emilie Hausberg, Anni Wood, Ulrich Brunner, Sénateur Vaisse, Dr. Andry. In this stand were

awarded the special prizes presented by J. G. Woodhouse, Esq., for the best H.P. and Tea or Noisette exhibited in the amateur classes. Mr. Budd, 8, Gay Street, Bath, was a good second with slightly smaller fresh blooms, amongst which Comte Raimbaud and Maréchal Vaillant were shown in fine condition. For eighteen varieties, three trusses of each, Mr. Grant's was the only entry, for which he was awarded a first prize. For twenty-four varieties, single trusses, Mr. Grant was again first with large fresh blooms of good form and substance, Mr. Budd following closely with slightly smaller but well-coloured fresh blooms. In the remaining class in this division for twelve single trusses, Mr. Grant was also first with a good stand; Mr. Bailey, gardener to W. A. H. Martin, Esq., Upper Hall, Ledbury, being second.

In division C, open to amateurs not exhibiting in division B, there was plenty of competition, especially for the special prizes given by Mr. Rankin, M.P., and Mr. Cranston, the former open to amateurs residing in Herefordshire only, and not exhibiting in division B, both classes being for twenty-four varieties, distinct, single trusses. Mr. Rankin's first prize was awarded to Mr. C. Williams, The Gardens, Lower Eaton, Hereford, for large well developed blooms; second Mrs. Graham, Lugwas Court, Hereford (Mr. Marrard, gardener); Mr. Cranston's prizes going to Mrs. Graham, Lugwas Court, and Mr. Nash, gardener to J. Rankin, Esq., M.P. For twelve varieties, distinct, Miss Bulmer and Mr. Merrick were first and second, the prize for twelve triplets going to Mr. Nash, and Mr. Williams in the order named.

Class D, open to all amateurs, for twelve Tea or Noisettes, the special prizes given by Mr. B. R. Cant were awarded to Mr. W. J. Grant and the Rev. H. Arkwright, Bodenham Vicarage. For twelve new Roses the awards were made in favour of Messrs. George Paul & Son, Cranston & Co., and Cooling, there being nothing particularly distinct amongst the varieties shown. Twelve trusses of any new Rose not in commerce previous to 1884 was represented by a box of Her Majesty, shown in fine condition by Mr. Cant, who was also first for twelve Teas or Noisettes, followed by Messrs. Cranston and W. J. Grant. Eighteen trusses of any one Rose brought six entries, Messrs. Cooling being first with a really splendid box of A. K. Williams, certainly the finest examples of this variety we have seen this year. One bloom in this box was surpassingly beautiful. Messrs. Harkness were second with Alfred Colomb and Messrs. Keynes, Williams & Co. third with Reynolds Hole.

Table decorations and bouquets were shown well as usual by lady amateurs, and also by Messrs. Perkins of Coventry and Cypher of Cheltenham.

#### BROCKHAM.

WHETHER or no Rose growers have had just cause to complain of the weather, members of committees of Rose associations have had no just cause. It has been perfect weather for every kind of out-of-door festivities, and treasurers of Rose shows have, no doubt, been in good spirits. The twenty-second Show of the Brockham Rose Association was held in the beautiful grounds of Mr. and Mrs. Gordon Clark at Mickleham Hall on Tuesday, July 12th. Owing to the Review at Aldershot on Saturday the 9th, the Show was of necessity postponed, but there was certainly no apparent disadvantage on account of the change of day. Mrs. Gordon Clark had asked 250 of her friends to a garden party, and the sight of the very large gathering in the grounds and the adjoining field was very brilliant and attractive. The gardens are well adapted for such gatherings. They abound in large well-grown trees planted with great judgment, and the visitors were distributed in clusters everywhere. The band of the Westminster Volunteers played at one end of the garden under an awning, and the selection of music was in excellent taste and admirably carried out. As usual, on every occasion of a Brockham Rose Show, hospitality and courtesy were extended to everyone connected with the Show. Mr. and Mrs. Gordon Clark not only entertained the Committee and the Judges at luncheon, but from first to last did their utmost to forward the interests of the Association. The grounds of Mickleham Hall do not possess any features that call for special mention in a horticultural view, but a large bed formed of trimmed Copper Beech and Acer Negundo var. in the centre, was a novelty, and very striking. The whole of the gardens under the care of Mr. Avis, who has been twenty-five years in Mr. Gordon Clark's service, were in admirable order, and the conservatory attached to the house with scarlet Tacsonia and double Hibiscus, and Tradescantia var. growing luxuriantly, was very well worth seeing.

The Rose Show was held in a large tent in the adjoining field, and the ventilation was so good that most of the Roses stood up as well at the end as at the beginning. It was a capital Show, and a great improvement on some of its predecessors. Attention had evidently been paid to defects previously noticed, and as a result the flowers generally were well staged. There were a very few unworthy blooms, the names of the Roses were fairly correct. There were exhibitors in every class, and there was not a single box without moss. Out of sixty-one members (the number is limited to seventy) there were eighteen exhibitors—viz., Rev. A. Cheales in four classes, Mr. C. E. Cuthell in eight classes, Mrs. Hatch, Lady Laura Hampton, Mrs. A. Tritton, Mrs. Benecke, Mrs. Mortimer in five classes, Mr. A. F. Perkins in five classes, Capt. Lang, Mrs. Gordon Clark, Miss Barclay, Mrs. Leopold Seymour, Hon. H. D. Ryder, Mrs. Blake, Mrs. Cockburn, Mr. F. T. Wollaston, Lady Moon in four classes, and Mrs. Thompson.

In the Class 1, for twenty-four distinct trusses, there were three exhibitors. Mr. Cuthell took first prize for Etienne Levet, Marquise de Castellane, Maréchal Niel, Rich. Wallace, Marie Rady, Gabriel Luizet, Ferdinand de Lesseps, Edouard Morren, Duke of Wellington, Duchesse de Vallambrosa, Alfred Colomb, Baroness Rothschild, Dupuy Jamain, Magna Charta, Duke of Bedford, La France, Royal Standard, Captain Christy, Baron Bonstettin, Hippolyte Jamain, Souvenir d'un Ami, Abel Carrière, Madame Lambert, Comtesse d'Oxford. Rev. Alan Cheales took second prize for Marie Ridy, Perle de Lyon, Mrs. Baker, Alfred Colomb, Charles Lefebvre, Maréchal Niel, Star of Waltham, Gabriel Luizet, Duke of Edinburgh, Gloire de Bordeaux, Souvenir d'Elise Vardon, Queen of Queens, Captain Christy, Sultan of Zanzibar, Duchess of Edinburgh, A. K. Williams (best H.P. in the Show), Madame Raimbaud, Etoile de Lyon, Comtesse de Serenye, Duke of Wellington, E. Y. Teas, Grace Darling, Marie Baumann, Catherine Mermet. Mrs. Mortimer had in her box, notably Reynolds Hole, Marie Baumann, and Marie Rady.



There were only five exhibitors in Class 2 for twelves. Mr. Wollaston won for a fine box the first prize, these were the Roses—Alfred Colomb, Jean Liabaud, Marie Baumann, La France, Baroness, Marie Rady, Comtesse de Serenyi, Charles Darwin, Harrisou Weir (a grand bloom), Louis Van Houtte, E. Morren, and Duke of Connaught. The Hon. H. D. Ryder took second prize for Lord Beaconsfield, E. Morren, Magna Charta, Alfred Colomb, Comtesse de Serenyi, Annie Wood, Catherino Mermet, Souvenir de James Gould, A. K. Williams, Belle Lyonnaise, C. Darwin, Etieune Levet. The third prize was won by Mr. A. F. Perkins for a good box.

In Class 3, for six separate Roses, there were four exhibitors. Mrs. Leopold Seymour won first prize for E. Morren, Lord Beaconsfield, Marie Baumann, Marie Sisley, Mrs. Welch, and A. K. Williams. Mrs. Hatch took second place for The Sultan of Zanzibar, Baroness, Marie Rady, Fisher Holmes, Madame V. Verdier, and Duchesse de Caylus.

The triplets in Class 4 were pleasing, but they should be in triangles, not in lines. Mr. Wollaston won first prize for Marie Rady, Alfred Colomb, Captain Christy, Baroness. Mrs. Mortimer took second prize for Reynolds Hole, Baroness, Marie Baumann, and Madame G. Luizet. The third prize fell to the Rev. A. Cheales—François Michelin, Alfred Colomb, Maréchal Niel, and Marie Rady. There were two other exhibitors.

In the six Teas, all alike, (Class 5), Mr. Cheales had it all his own way for a gleaming box of Maréchal Niel, Mr. Cuthell came next for other Maréchal Niels, and Mr. Perkins for six small Comtesse de Nadailles won third prize. The gold medal was ruled to lie between the best boxes in Classes 5 and 6. Mr. Cheales and Mr. Cuthell, through winning the medal previously, were not qualified. Consequently, as the medal could not go for a third prize, it was not awarded. The rule of the Committee requires alteration.

For six blooms of any other one sort, Mr. Cuthell got first for Marie Rady, and Mr. Thompson second for the same Rose. Mrs. Leopold Seymour won third prize for six blooms of Her Majesty. When it has been said that they were enormous little more is left to be said. Two of the blooms were each as big as saucers, and amazingly flat. This box received much attention, if not respect. There were four other exhibitors in this class.

For twelve Teas, Mr. Cuthell won first prize for Jules Finger, Maréchal Niel, Souvenir d'un Ami, Madame Berard, Madame Lamhard, Sunset, Marie Van Houtte, Elise Vardon, Perle des Jardins, Alba Rosea, Innocente Pirola, Réve d'Or. Mr. Cheales came next for a good twelve, containing G. de Bordeaux (? a Tea), Niphotos, Hon. E. Giffard, Grace Darling, and The Bride. Mrs. Mortimer took third prize. There were no other exhibitors.

For six Teas, Class 8, Mrs. Leo. Seymour took first, and Miss Barelay second prize. There were four other competitors.

In Class 9, open to all previous non-winners, Lady Laura Hampton took the prize. There was one other exhibitor. Mrs. Seymour took the silver medal for Maréchal Niel, the best Tea, and Mr. Cheales the same for A. K. Williams, the best H.P.

For the decorations there was keen and good competition. Mrs. Cuthell took first prize for a high dinner decoration of Tea Roses and Ferns, very elegant. Mrs. Benecke for a copper bowl, with Beech, Ribbon Grass, and Roses, took second. Mrs. Blake won first prize for drawing-room decorations of Eucharis, Purple Beech, and Fern. Miss Ede, second prize, for a vase of Honeysuckle. Miss Gordon Clark, third, for an elegant basket of Roses and Fern. Mrs. Hatch won the prize for a hand bouquet (only one exhibited). There were forty-two buttonhole bouquets shown, many were much too large. The Judges were well abused by the ladies for their judgment; but, oddly enough, no two ladies who gave their opinion agreed together. Miss Cuthell took first for buds and Orchids; Mrs. Hatch, second, for buds of Forget-me-nots; and Mr. Thomson third for dark buds and William Allen Richardson.

Mr. T. W. Girdlestone, of Sunningdale, showed a box of new Roses—Mary Bennett, Madame Musset, Comtesse de Paris, Rosieriste Chauvy, Clara Cochet, Benoit Comte, Annette Murat, Souvenir de Victor Hugo, American Beauty, The Bride, Madame Caroline Swails; and also a box of Teas, amongst which were Berberidifolia Hardyi (a gem), Rosa macrantha, and Rosa indica (var.), Princess Vera (T.), Marcellin Rhoda, Souvenir de Thérèse Levet, and Triomphe de Milan.

Mr. H. Appleby of Boxhill Nurseries, decorated the tent with choice flowering plants, and also showed two very fine boxes of H.P.'s and Teas, and several brace bouquets arranged by Mr. Appleby.

Mr. Mawley was not able to act as Judge, being called to Edinburgh. His place was ably filled by Mr. Bensted, Hon. Sec. of the Maidstone Rose Association, and so it was that the Judges consisted of Mr. Girdlestone, Mr. H. Appleby, Mr. Bensted, and the writer of this account.—A. B. ALEXANDER, *Shedfield Vicarage.*

### VINE BORDERS AND UNORTHODOX PRUNING.

As our friend, "A Thinker," states at page 6, it is almost too hot to think and write, and especially so after a hard day's work, such as the weather necessitates; but "Experientia docet" has set the ball rolling on a worthy subject, and readers may dwell with interest on those pithy remarks concerning the grand old Vines at Cole Orton Hall—I mean those in the old brick pit. Does it not show what a mistake it is to have such large borders as are usually seen? and I have been wondering lately what will be the fate of many a house of Grapes six weeks or two months hence, where the roots are rambling away far out of the original border. The present season so far is one of the driest on record, and the languishing state of many Vines, where the roots are not under control, will plainly show that they are suffering through the drought. Those in charge will water the border; this will help them a little, but the bulk of the feeders being away out of the border none of the water will reach them. I have a vivid recollection of two instances where the Vines are in brick pits, and the gardener in charge, knowing the small size of the border, gave unlimited supplies of liquid manure, besides rich top-dressings, and the Grapes were much better both in quality and finish than others in large and deep borders. At the present time we have Vines of Muscat of Alexandria in 11-inch pots bearing two 4 lbs. bunches on each Vine; the berries are very large and of perfect finish.

They have been kept well top-dressed and well supplied with liquid manure. This plainly shows that, the roots being under control, they receive the benefit of whatever is applied.

My advice to those in charge of large and deep borders is, after the Grapes are cut make a trench about 6 or 8 feet from the main stem, and carefully work the soil from the roots, taking particular care that they do not become dry in the operation. If the drainage is not in good order it should be rectified and the roots relaid in fresh compost. A thorough watering with tepid water and a mulehing of fresh stable litter will complete the operation. If the borders are inside and out, one could be done one season and the other the next. I have lifted and relaid the roots of Vines in seven houses in my time, and I have also pruned Vines in six houses on what is called "unorthodox pruning," and with very pleasant results. "Red" Hamburg even turned into Black Hamburg, and shanked and shrivelled Muscats into what my late employer called grand Muscats. I have a letter by me now in which he speaks of the Grapes in the highest praise. We have a house of Muscats here which have been in an unsatisfactory condition for several years. Last October we lifted the roots in the inside border, and pruned them on the long-spur system, and they have very much improved. I do not say they are perfect, but they are in advance of what they were last season. We know it is pleasant to see straight and trim rods, but when you have Vines placed under your charge from ten to thirty years old, not in good condition, and good Grapes expected, we must make a move out of the orthodox groove. Well ripened Vines in pots never throw straggling bunches, and it is the same with old Vines.—A. YOUNG, *Abberley Hall Gardens, Stourport.*

### PRIMULA REIDI.

THE plant represented by the illustration (fig. 5) is a new introduction from the Himalayas. It was discovered on wet rocks near the Ralan Glacier, Kumoan, by Dr. Duthie of Saharunpore, who sent over a large quantity of seed, and which was widely distributed. Although



Fig. 5.—Primula Reidi.

we have heard of a few failures, the majority of growers seem to have raised it in large quantities, so that there will be no fear of its being lost if it ripens seed anything like the other Primroses from that country. It has been reported as not having much horticultural merit, but this we think is due more to the anxiety displayed in being the first to get a certificate than anything else. The plants exhibited at Kensington were very small, carrying only about three flowers, and these small and badly coloured, while strong plants grown on with us this year have borne a head of from six to nine flowers larger than *P. involucrata*, and pure white or cream colour, and delightfully fragrant. Small plants have also a disadvantage in not opening their flowers fully, while in the more robust plants they open quite flat, and when grouped make a grand show. The leaves are ovate, obtuse, rough or wrinkled on both surfaces, covered with long white hairs, and do not attain a very large size. As far as our experience goes about the hardiness of *P. Reidi* we should say that it is quite equal to *P. rosea*, not requiring such a damp situation as that species, but well protected and grown in shady places with us it has stood the last severe winter where fully exposed, and this



spring the fine healthy appearance and large flower heads proved beyond doubt its capability to stand the rigour of even our most severe winters. As a pot plant it does admirably. Our compost is good stiff loam, leaf soil, and plenty of sand, the tiny seedlings being placed between small pieces of sandstone, which retains sufficient moisture near the roots for their requirements. There can be little doubt when this plant becomes better known it will take a place equal to *P. rosea*. Our plants are small as yet, only a year old, but what we have already seen speaks well for its future. The drawing was taken from plants that flowered at the Royal Gardens, Kew, this spring.—M. S.

[The Rev. H. H. D'Ombraïn has also favoured us with flowers of this charming little *Primula*, and he speaks very favourably of it.]

### WINTER GREENS.

JUST now vegetables are plentiful in all gardens. Cultivators who plant the garden from beginning to end during one of the spring months, and then await results without further exertion, may now be in possession of a full supply of vegetables. As soon as the summer ceases and the winter comes on these growers find their garden entirely destitute of vegetables, and in many cases there is none worth speaking about to be found in gardens from November until the following May. This is a state of matters I can remember seeing in gardens twenty-five years ago, and discreditable as it was then, it is still more so now, as teaching on gardening is more common than it ever has been. That empty gardens are frequently seen in winter and spring no one can deny, and although the majority of these may be small, many large ones are also very deficient in this way.

This is wholly the result of neglect and the want of thought. I know scores of small garden owners near here who ten years ago were under the impression that it was quite the correct thing to have their gardens empty in winter that now have them as full at that season as they are at midsummer, and they wonder that they had not always been so. Local societies set them the example, and once begun, the results were so good that no inducement was necessary to make them give as much attention to their winter crops as their summer ones.

Allowing the time of planting to slip by, or not taking the trouble to put the crops in, are faults which invariably lead to insufficient supplies in winter, and it is not until vegetables are wanted that the great mistake is discovered, for Broccoli, Brussels Sprouts, Savoys, Kale, Leeks, &c., are just as valuable in January, February, March, and other months as Peas, Kidney Beans, and such like are at the present time. There is no use in anyone being advised or advising themselves that they have no room to plant Winter Greens in their gardens in summer, or so long as the planting season lasts, as vacancies are being made in almost every garden daily. Now and by August many of the early Potato, Pea Cauliflower, and other quarters will be cleared, and it is by planting these up weekly from July until the end of August that a good supply of Winter Greens is insured. I know some growers who have only a small garden that plant Winter Greens between their Potato rows so soon as the Potato stems begin to die, and as they raise their own plants from seed in little beds close by they are constantly filling the vacant spaces, no matter how small they may be, and the result is that there is not a day in the whole year but some vegetable is forthcoming from the garden. They have an all-the-year-round supply, and to secure this ought to be the leading desire of every garden holder. Some are inclined to think that Curly Greens and Leeks are too common, but if they will revert to March last they may remember how valuable every vegetable was at that time, and this may induce them to plant some of the more hardy Greens, Swedish and Yellow Turnips, and Prikly Spinach should also be included amongst Winter Greens, as they fill an important gap in the supply of winter vegetables, and the absence of Turnips in winter is more felt than many think at the present time.—J. MUIR.

### CERTIFICATED PLANTS.

ATTENTION was directed some time ago to an alleged circumstance of a number of members of the Floral Committee of the Royal Horticultural Society refraining from voting either for or against plants placed before them for certificates, and no account being taken of these abstentions in making the awards. It was pointed out that under that extraordinary system plants might be honoured with certificates for which the great majority of the Committee refused to vote, the honour (?) being granted by a minority. If I am correctly informed that has been the case somewhat recently, for it is stated that not many weeks ago a plant was certificated on the votes of two members of the Committee, one voting against it and the majority abstaining. It is difficult to believe in the accuracy of that allegation, but it is so freely mentioned by persons who cannot be ignored that publicity is given to the rumour in order that it may be contradicted if not well founded. If it be true, and a practice so utterly loose is officially sanctioned, the public will soon cease to attach any value to the decisions of the Committees, and the Society must inevitably suffer. Here, if there is no mistake in the matter, is a plant franked with the highest mark of merit that can be bestowed—the first-class certificate of the Royal Horticultural Society of England—that was not considered good enough for an award by an overwhelming majority of the Floral Committee, and yet this negatively condemned

plant goes to the world as of equal merit with another that may have been accorded an unanimous mark of approval. If this is not deceiving the public as to the real value of a plant (for which a higher price will be charged in virtue of the honour (?) accorded), it would be interesting to know what is. All abstentions should be regarded as negative votes counting against a plant, or certificating will become a solemn farce.—ANTI-HUMBUG.



ROSE SHOW REPORTS.—We desire to express our obligation, to all who have assisted in the preparation of the complete reports of Rose shows that have been furnished to us. We have had pleasure in affording space for them, though the publication of some practical and interesting articles has been in consequence postponed.

— THUNDER SHOWERS visited the metropolitan district last Friday and Saturday, the weight of rain falling varying considerably in different localities. It was the first "good rain" that had fallen for six weeks, and was of the greatest possible benefit to vegetation. The air has also been cooler and more pleasant since the showers.

— SHOW AT THE PEOPLE'S PALACE, LONDON.—We learn that a large flower show will be opened by H.R.I.H. the Crown Princess of Germany at the People Palace, Mile End, on Monday, 25th inst., and will continue open until July 26th. Many leading London nurserymen will make extensive displays of plants and flowers. It is under the management of Mr. William Earley.

— ON Tuesday next, July 26th, the NATIONAL CARNATION AND PICOTEE SOCIETY will hold their annual Show in the Conservatory, South Kensington, on which day the usual Scientific, Fruit, and Floral Committees will be held. The price of admission to the public will, we are informed, be 2s. 6d.

— VAN HOUTTE MEMORIAL PRIZES.—We are informed that the Committee of the English subscribers have determined to offer two prizes of the value of £10 each, to be competed for at the next quinquennial International Exhibition to be held in April, 1888, at Ghent, under the auspices of the "Société Royale d'Agriculture et de Botanique," one prize for the best new varieties of *Azalea indica* obtained since 1880, and one prize for the best collection of hardy trees and shrubs. The Conseil d'Administration of the Society have intimated their acceptance of these prizes.

— ON the occasion of the Queen's Visit to Hatfield on the 13th inst. the daughter of the Marquis of Salisbury's head gardener, Mr. Norman, had the honour of presenting Her Majesty with a bouquet of Orchids.

— AT the ROYAL HORTICULTURAL SOCIETY'S MEETING, South Kensington, last week Messrs. J. Laing & Co., Forest Hill, received first-class certificates for the two following TUBEROUS BEGONIAS, in addition to those noted in our report:—Claribel, bright rose, white centre; *Rosea compacta*, very dwarf, free flowering, single. Both were handsome varieties, the total number of varieties from the same firm certificated on that occasion being nine.

— THE ROSE SHOW AT THE ALEXANDRA PALACE last Thursday, Friday, and Saturday was far from being as satisfactory as some exhibitions held there in past years. Some had anticipated an extensive Show, but their hopes were not realised, partly perhaps owing to the season, and partly to some defects in the management. The principal exhibitors were Messrs. Paul & Son, C. Turner, W. Rumsey, G. & W. H. Burch, J. Burrell & Co., H. Low & Co., G. W. Piper, E. B. Lindsell, Rev. Alan Cheales, and J. Bateman. Messrs. Wood & Sons' Jubilee medal for the best single bloom in the Show was awarded to Mr. G. W. Piper for a good example of Her Majesty. Mr. T. S. Ware, Tottenham, had a large and beautiful group of hardy flowers; and Messrs. W. Paul & Son, Waltham Cross, contributed an extensive collection of eut Roses.

— MR. HENRY MARRIOTT sends us from Skirbeck a pod of WEBB'S WORDSLEY WONDER PEA, containing twelve full-sized seeds,

and observes there are many other pods containing the same number of peas. Mr. Marriott desires to know whether it is a rare or an ordinary occurrence to find twelve full-sized peas in a pod. We suspect it is not common to find such a yield, but we have seen a pod containing thirteen peas. If any other pods are sent containing twelve or more peas we will record the circumstance as representing a bountiful yield.

— GARDENING APPOINTMENT.—Mr. James Wilkie, for the last five years at Cardiff Castle Gardens, has been appointed gardener to Lord Oranmore, Castle Macgarrett, Claremorris, Ireland.

— MR. ROBERT OWEN sends us flowers of his "last and best" IVY-LEAVED PELARGONIUM ROBERT OWEN. It equals in size, form, and symmetry the flower sent to us last week, and referred to on page 27, but has slightly broader petals. It is a splendid variety, rosy scarlet in colour, the "Princess Josephine" being deep carmine. We have not seen two better double Ivy-leaved Pelargoniums than these.

— WE have received the schedule of the HUDDERSFIELD CHRYSANTHEMUM SHOW. The chief prizes in the open classes for cut blooms were £10, £7, and £4 for twenty-four Japanese, and the same number of incurved, distinct, and £5, £3, and £2 for twenty-four varieties, twelve in each section. The Show is to be held on November 11th and 12th in the Town Hall, Huddersfield.

— "D." writes that in the report of the FARNINGHAM SHOW it should have been Mr. F. Cant, not Mr. B. R. Cant, who was the exhibitor and second prizetaker in the nurserymen's class for thirty-six blooms.

— ROSES AT THE AMERICAN EXHIBITION.—Messrs. W. Paul and Son, Waltham Cross, have a tent at the American Exhibition, Kensington, devoted exclusively to Roses, which are arranged in boxes and baskets on sloping banks at the sides, with a broad path down the centre. About 2000 blooms are exhibited each day, fresh supplies being obtained every morning from the Waltham Cross Nurseries. All the best of the standard exhibition and garden varieties are represented, including selections of the new varieties, such as Grand Mogul, of superb colour; the pretty American Rose, Sunset, and others. Some stands of old garden Roses have been very attractive, the graceful Polyantha varieties also being well shown. These are arranged in baskets suspended from the upper part of the tent, and have a charming appearance. The tent altogether is a very pleasing addition to the Exhibition, and the gardens attached are now very attractive.

— THE WAKEFIELD PAXTON SOCIETY.—The subject for discussion at the ORDINARY WEEKLY MEETING of this Society, held at the "Saw Inn" was "The Pelargonium," and it was introduced by Mr. T. Marsden of Sheffield. In the absence of the Vice-presidents Mr. W. J. Ireland, head gardener to Baron St. Oswald of Nostell Priory was called upon to preside, and the vice chair was occupied by Mr. W. L. Skinner of Silcoates Nurseries. There was a good show of blooms, particularly of the Zonal and Regal varieties. Some discussion took place on the paper, and a series of questions were put to the essayist. On the motion of Mr. Hale, gardener at Woodthorpe, seconded by Mr. E. Fenner, gardener to Mr. Jo. Shaw of Woodlands, Sandal, and supported by Messrs. Skinner & Garnett, a vote of thanks was accorded to the essayist.

— MR. PATRICK MCKENZIE MCKIE of Teddington sends us flowers of a DOUBLE SEEDLING PETUNIA possessing considerable merit. The flowers are large, full, well formed, the colour being a bright rosy mauve, very effective and pleasing. It somewhat resembles a variety which has become a favourite for arranging in groups of miscellaneous plants, but is lighter in colour.

— THE DUTCH BULB TRADE.—We are informed that the Royal General Union for the Cultivation of Flower Roots at Haarlem held an extraordinary general meeting recently, which was attended by a large number of its members, among whom are the principal growers of bulbs and the members of the bulb trade. At this meeting it was stated that the unusual cold weather of this spring has caused all growing crops to be very backward, and in consequence the flower roots, more particularly the Hyacinths, will not come to full maturity at the usual time, so that exportations will be effected at a somewhat later period than usual.

— THE same Society as that above mentioned also call attention to the following matter—"The exportation in cut flowers from Holland

to foreign countries, and especially to England, increased last spring in such an extraordinary manner that it is expected that the trade in flower roots will be much damaged. The foreign markets were during the flowering period of Hyacinths, Tulips, and other bulbous plants so overstocked by the flowers of these plants, that their value was greatly reduced. The growers of and dealers in bulbs are generally of opinion that such transactions must be stopped for the future, and in consequence the Royal General Union for the Cultivation of Flower Roots at Haarlem has passed a resolution to do everything possible to engage all growers of bulbs to contract not to sell or to send out any cut flowers of Hyacinths, Tulips, Narcissus, Ranunculus, and Anemones, except for exhibition purposes, or for small samples under three kilograms. Besides, there are other measures in preparation in view of making this trade in cut flowers impossible for the future."

— No. 7 of the KEW BULLETIN, the issue for July of the present year, contains an article on the Annatto, Bixa Orellana, and some farther correspondence relative to botanical stations in the West Indies. The Annatto is chiefly valued for the colouring matter obtained from the seeds, but the supplies have hitherto been obtained from trees in a wild state in tropical America, the uncertain demand and low prices having rendered its culture unremunerative. There appears to have been some advance in the trade recently, and the authorities at Kew have accordingly prepared some particulars as to its mode of culture, cost of production, market value, &c.



#### LÆLIA BATEMANNIANA.

BARON SCHRODER, The Dell, Egham, submitted to the attention of the Floral Committee and orchidists present at the Royal Horticultural Society's meeting on July 12th a plant of one of the most remarkably interesting hybrid Orchids yet obtained by Messrs. J. Veitch & Sons, Chelsea—namely, *Lælia Batemanniana*. There is quite a little history connected with this plant, apart from its structural peculiarities and strange origin. At the Orchid Conference in 1885 Mr. James Bateman proposed a vote of thanks to Mr. Harry J. Veitch for the paper he read on that occasion, and in doing so made the following remarks:—

"I have particular pleasure in proposing a vote of thanks to Mr. Veitch for his admirable paper. I am sure that he, and Mr. Dominy also, will know and appreciate the effort it costs me to make this proposal, for I have been brought up with the very strongest abhorrence of hybridisers. I fell into evil hands early in life. My first Orchid-growing friend was Mr. Huntly. When I paid Mr. Huntly a visit at his snug rectory in Huntingdonshire he pointed out to me his Cacti and his Orchids, and said, 'I like those plants, in fact they are the only plants I grow, because those fiends (meaning the hybridisers) cannot touch them.' You must make a little allowance for a botanist, for hybridisers do give botanists a lot of trouble; but, however strong my prejudices were, I must confess that when I saw such plants as the *Cattleya* downstairs, if I was not converted, I was at all events, what comes to the same thing, shut up. I have the greatest pleasure in moving this vote of thanks to Mr. Veitch."

In acknowledging the compliment Mr. Veitch observed that "Mr. Bateman is such a kind-hearted genial gentleman that many a time I have asked myself why, when he came into my houses, he used to act in such an extraordinary manner when he saw a hybrid. Now I have found it out; it was this friend of his whom he has mentioned who set him the bad example. However, I am very glad to find that Mr. Bateman has lived sufficiently long to get rid of his prejudices against the hybrids, and I hope I shall before long be able to name one after him."

The hope was soon fulfilled, for this hybrid flowered the following year, and was at once selected as well fitted for honouring Mr. Bateman as suggested, for it is a really beautiful as well as a remarkable Orchid.

My first descriptive note concerning this plant appeared in an article on Bigeneric Orchids, published in this Journal on August 12th, 1886, and it may be here introduced.

An exceedingly important addition has been made to these

bigeneric hybrids by a cross between *Sophronitis grandiflora* and *Cattleya intermedia*, and though when the statement was first made that plants had been raised from crosses between *Cattleya* and *Sophronitis* it was received rather incredulously by some, yet the matter is now satisfactorily proved by a plant that has just flowered in Messrs. Veitch & Sons' Chelsea Nursery. This is one of the Sedenian experiments, the *Sophronitis* having been fertilised with pollinia from *Cattleya intermedia*, and the seed resulting from this cross was sown five years ago. Several plants have been showing flowers for some weeks, and on one of these the long-expected flower opened a few days ago and revealed the fact that a satisfactory bigeneric cross had been accomplished. The plants are as yet small, and the one which has flowered is the weakest, so that a fair estimate can scarcely be formed of the real merits of the hybrid.

have of *Sophronitis grandiflora* appears under the name of *Cattleya coccinea* with a figure of *Cattleya intermedia pallida* in the "Botanical Register" for 1836, and of the former Lindley says, "Stems 2 or 3 inches high; flowers bright scarlet, 3 inches across, a most remarkable and beautiful species." Subsequent examination of other specimens, however, and the introduction of living plants, determined the reference of "*Cattleya coccinea*" to the genus *Sophronitis*, and it has been accepted as distinct by succeeding authorities. It would be rather strange if after all the original name should be found to be an appropriate one, and the fact that a cross has been obtained with the *Cattleya* would seem to indicate that the relationship is nearer than has been supposed. The late Mr. G. Bentham classed both genera in the tribe *Epidendreae*, sub-tribe *Laeliæ*, the chief characters of the latter residing in the



Fig. 6.—LÆLIA BATEMANNIANA.

The growths are slender, 2 to 3 inches high, with oval leaves 1 to 1½ inch long. The flowers 2¼ inches in diameter, like the *Sophronitis* in general outline, the sepals elliptical rather acute, the petals oblanceolate, and both of a light rosy purple tint—a rather curious shade, and having somewhat the appearance of an underlying tint, probably the effect of the *Sophronitis* colour, though it is strange that such a distinctive hue is not more strongly marked. The lip is like that of a small *Cattleya intermedia* with the wings curving over the column, white, and the central lobe, which is much more rounded than in the *Sophronitis*, is of an intensely rich crimson, and very finely edged with white, as is often seen in the *Cattleya* named. The column is white faintly margined with crimson, and is very pretty resting in the white throat of the lip. With stronger plants we may expect to see the characters more nearly resemble *C. intermedia* in robustness, for, of course, at present the difference in this respect is very notable, though there is ample indication of the share the *Cattleya* has had in the parentage.

It is somewhat peculiar that the first published description we

pollen-masses, which are either four in one series or eight in two series. *Lælia*, *Schomburghkia*, and *Sophronitis* are associated together as instances of those with the two series of four pollen-masses each, equal or nearly so. In a paper contributed to the Linnæan Society's Transactions the same author observes that "*Lælia* is so closely allied in every respect to *Cattleya* that one has great hesitation in accepting the technical distinction of the eight pollen-masses in two series instead of the single series of four (as in *Cattleya*), especially as hybrids are so readily produced in cultivation in which the number of pollen-masses is variable." The relationship of *Sophronitis* through *Lælia* to the *Cattleyas* is therefore apparently rather close, and it will be interesting to learn in what way the pollinia characters of the hybrid have been affected, which Professor Reichenbach, to whom the plant has been referred, will no doubt dilate upon.

Upon a careful examination it was found that there were eight pollinia in the flowers, and it was in consequence referred to the genus *Lælia*, the peculiar result being that hybridising a *Cattleya*



with a *Sophronitis* had produced a *Lælia*. Some doubt has been expressed whether the pollinia characters will remain constant, and whether they are all fertile, but the flowers borne by the plant exhibited from The Dell Gardens seemed identical with those previously produced, except that they were finer and of richer colour. It has evidently thriven under Mr. Ballantine's charge, for it had two racemes of three and two flowers each, the sepals and petals possessing a peculiar rosy satin-like lustre or crystalline appearance closely resembling that seen in *Impatiens Sultani*, with the faintest violet tinge occasionally perceptible in a favourable light.

#### ONCIDIUM DASYSTYLE, DR. WOODFORDE'S VARIETY.

MANY Orchid growers are familiar with the graceful and peculiar little *Oncidium dasystyle*, as the dark crest at the base of the yellowish lip much resembles the body of a bee. The plant was imported by Mr. B. S. Williams from the Organ Mountains, Brazil, and was figured in the "Botanical Magazine," May, 1880 (T. 6494), and the form there depicted has been that generally seen in collections until quite recently. Dr. W. T. G. Woodforde, Oakbank, Spencer's Wood, Reading, has, however, forwarded a flower of a variety in his collection that is greatly superior to the ordinary type, considerably larger, brighter, and more delicate in colouring and markings. In the type first figured the flowers were  $1\frac{1}{4}$  inch in diameter, in this they are  $1\frac{3}{4}$  inch from tip to tip of the petals. The sepals and petals are three-eighths of an inch broad at the base, pale yellow, heavily and clearly spotted with purplish brown, especially at the base. The lip is of a delicate creamy yellow tint, is 1 inch in diameter, five-eighths of an inch across the centre from the base to the margin, slightly indented at the apex, uniform, contracted at the base into a narrow claw, with a dark purplish black rounded projecting crest, which has a curious effect in contrast with the pale tint of the other portion of the lip. The column has two rounded wing-like projections near the top, spotted at the inner surface with pale purple.

Dr. Woodforde has favoured me with the following particulars:—"I received it direct from Brazil (Rio Janeiro) two years ago, it being one of a parcel of some fifty Orchids brought home for me by my son, Dr. Sidney Woodforde. I was fortunate enough to have hardly any losses in starting them, and since then they have, without a single exception, thriven and done well in a cool 'general utility' house, size 30 feet by 10 feet (glazed on the non-puttying system and amply ventilated). They have had to put up with ordinary treatment, as the house also contains some young Vines and climbing greenhouse plants, as well as the usual contents of such a house in their various seasons. They have grown vigorously and flowered, some last year, while others which had not then sufficiently established themselves have now done so, and promise well for bloom. In managing my Orchids I have been guided mainly by your admirable little book, with occasional references to Williams and other writers on them, and I need hardly say that they are a source of continual and daily interest to me. Last summer some plants of *O. dasystyle* of the ordinary type bloomed with me and are now flowering again or showing for bloom. The variety of which I sent you a flower has a spike some 22 inches in length, bearing eight blooms on the upper 8 inches. There is some little difference in the leaf of this and the ordinary kind."

I am informed that Sir Trevor Lawrence, Bart., M.P., Burford Lodge, has a variety resembling this, which was purchased last year at one of the sale rooms. H. M. Pollett, Esq., Bickley, also has a handsome variety, but differing from this in several points.—LEWIS CASTLE.

#### AMONG THE ORCHIDS.

UNTIL very recently, says the *Bradford Observer* of July 8th, we were unaware that the importation of Orchids had become an adjunct to the staple trade of Bradford, but a visit to Heaton clearly testified to the fact, for upon the slopes of Heaton Reservoir Mr. Joseph Charlesworth, wool merchant, has established an emporium for receiving these floral treasures from all parts of the globe where Orchids are met with.

It is only comparatively recently that Orchids have been cultivated to the extent that they now are, their great value and the difficulty formerly found in growing them operating considerably in restricting their cultivation. Orchid-growing is, however, no longer exclusively the privilege of the few, although the rarer varieties can only find their abode with such as are able to pay high prices for them. Of the *Cattleyas* Mr. Charlesworth has in stock about fifty distinct varieties. The *Odontoglossums* are pre-eminently among the most prized of the Orchids, and they are very strongly represented at Heaton. There are not fewer than thirty varieties, and of *Odontoglossum Alexandræ* or *crispum* over 15,000 plants. The latter Orchid is a charming addition, and one which affords many variations, ranging from pure white to yellow or rose, and including various highly spotted forms. Some of the latter have been sold by auction in London for 160 guineas. Of this species, as

indeed may be said of other Orchids, scarcely two flowers will be found to be exactly alike. The demand for these plants has become very great, and it is not to be wondered at, for they are lovely, and can be grown in a cool house at less expense than the more stately Brazilian and East Indian Orchids.

*Cypripediums* form a remarkably distinct genus of the Orchid family, consisting partly of terrestrial and partly of epiphytal species. They are generally known as the Lady's Slipper Orchid, the form of the flower somewhat resembling a Turkish slipper. Many of the species have beautiful foliage as well as flowers. In Mr. Charlesworth's nursery there are about seventy-five varieties from the East Indies, South America, &c. The *Oncidium*s are among the oldest importations to this country, some 250 varieties having been recorded. They are all evergreen, and make fine plants both for exhibition and decorative purposes. The collection at Heaton comprises twenty-two varieties. It would be undesirable to name in detail all the many varieties of Orchids to be found in this notable collection. The following are among the chief sorts—viz., *Ada aurantiaca*, *Aerides* (various species), *Angraecum*, *Calanthe*, *Cœlogyne*, *Cymbidium Lowianum*, *Dendrobium* (thirty varieties), *Epidendrum*, *Lælia* (twelve varieties), *Masdevallia* (twenty varieties), *Phalænopsis*, *Saccolabium*, *Vanda*, *Zygopetalum*, growing on the stem of a Tree Fern (*Alsophila ferox*), from Brazil.

Like many other species of great rarity, some of the Orchid family are far from being prolific in bloom. The process of raising new varieties is even more tedious work still. We saw seedlings fifteen months old not the size of a finger nail, and two years must elapse from the time of sowing before any real sign of progress is made. This tardiness is, however, all forgotten when the flowers appear. It is then that Nature, in her most compensating mood, makes up for any apparent defect in the construction of the plant. There are three suitable structures at Heaton, one 150 feet in length for the tropical specimens, and two cool houses, each 100 feet in length, besides accessory buildings. These erections are completely stocked with Orchids, ranging from half a guinea to 50 guineas each. Mr. Eichel, the manager, has an extensive knowledge of Orchid culture, and an evident pride in the large collection in his charge.

#### ROYAL HORTICULTURAL SOCIETY.

JULY 12TH.

SCIENTIFIC COMMITTEE.—Present—Dr. Lowe, in the chair; Messrs. O'Brien, Wilson, W. G. Smith, Boulger, and Dr. Masters.

The meeting was but thinly attended, and the objects brought before it on this occasion were not numerous.

*Hay Fever*.—Mr. O'Brien made some comments on a paragraph recently published in the columns of the *Gardeners' Chronicle*, and detailed his own experience with reference to the flowers of Golden Feather, *Artemisia* insect-powder (*Pyrethrum*), *Hibbertia volubilis*, *Patchouli*, *Lilium auratum*, and other plants, by the perfume of which he was to a greater or less degree affected. Other cases of a similar kind were mentioned by members of the Committee, the general inference from the varied nature of the plants, being that the real causes of the symptoms must also be varied, and that the pollen alone cannot be credited with the mischief.

*York and Lancaster Rose*.—The Chairman showed a specimen of a Rose which this year had produced on the same stalk a red Rose and a white Rose. Dr. Lowe stated, on the authority of the late Rev. H. Ellacombe, that the Damask Rose with striped petals, now commonly called the York and Lancaster Rose, is not rightly so called. Dr. Masters alluded to other instances of dimorphism in Roses, attributable to the sudden dissociation of previously combined hybrid characters.

*Celestial Rose*.—Dr. Lowe exhibited a specimen of this old Rose, remarkable for its very glaucous foliage, its elegant light rose flowers, and delicious perfume.

*Double Campanulas, &c.*—Rev. C. Wolley Dod sent a curious form, which seems to have a regular place in the history of that very variable species, *Campanula rotundifolia*. The form with the corolla cleft into narrow segments is generally produced in greater or less proportion from the seed of the form with the double corolla. I have never found either of these two forms wild, but the one with double corolla, known in nurseries as var. *soldaniliflora*, is not uncommon in gardens; and the other, of which I send both double and single flowers, seems to follow it in natural sequence. I enclose also the single form produced among seedlings with the other two.

*Hybrid Lychmis*.—Dr. Masters called attention to the interesting hybrid between *L. coronaria* and *L. Flos-Jovis* sent him by A. O. Walker, Esq.

#### ROSE SPORTS—INSECTS.

LAST evening I found a bloom of Baroness Rothschild upon a plant of *Merveille de Lyon*. There is no doubt whatever about it. It is a singular proof of the breeding-back theory. I presume I am correct in the idea that the latter Rose is a seedling from Baroness Rothschild.

Have any of your readers, I wonder, been troubled this year with

a nimble little bright green insect, which eats the very young leaves at the tips of the fresh growing shoots? It is most destructive in my garden this year. I remember some years ago the same enemy causing great annoyance to Mr. S. Mount of Harbledown.—HENRY B. BIRON, *Lympe Vicarage*.

### PINKS—THE DOUBLE LYCHNIS VISCARIA.

AMONGST our hardy plants what can surpass the exquisite fragrance of the Pinks? The old white fimbriata is still a good plant, and happily the occupant of nearly every garden, hence a general favourite. It lacks the size of Mrs. Sinkins certainly, but the unfortunate drawback in the latter plant is the matter which its pods—*i.e.*, calyx, burst ere the flowers expand. I doubt not but that this will have to give way presently to still better forms, for it is much below the standard of perfection which our florists claim as right. *Lychnis Viscaria splendens plena* is one of those choice border plants which should find a place in many gardens from which it is now excluded. The colour is a rich magenta, and stands almost, if not quite, alone in this respect. It will grow in almost any situation or soil, possesses the sterling qualities of free flowering, perfect hardiness, with easy means of propagation—*viz.*, by dividing the root-stock. Those unacquainted with it I would ask to imagine a tufted cushion of leaves similar to some Thrifts, from which issue numerous flower stems to a height of 18 inches, closely packed with bright magenta flowers, very useful for cutting. Its extreme beauty is in the embellishment of the hardy plant border or rock garden, where the flowers retain to the last that brilliant hue of colour which renders it so conspicuous at this time. Planted in patches it has a most effective appearance.—J. H. E.

## HORTICULTURAL SHOWS.

### BEDFORD AND BEDFORDSHIRE HORTICULTURAL SOCIETY.

THE fourth annual Show of this Society, competition for which is mainly confined to the county, was held on Wednesday, July 13th, in an admirably adapted and centrally situated ground on the Goldington Road, Bedford. The Committee is to be congratulated on the success that attended their well-directed efforts, notwithstanding the severe drawback caused by the long-continued drought, the effects of which have been especially marked in this district, and were patent in the display of outdoor products at this Show, which, with the general exception of Roses, were in most of the classes deficient in size and appearance. For Roses and herbaceous plants there are open classes, and in those for Roses the competition was not only strong in all the classes, both open and local, but the blooms were quite up to the average.

In the open class for forty-eight cut blooms, distinct, Messrs. J. Burrell and Co., Howe House Nurseries, Cambridge, took the lead with a fine even stand containing good blooms of François Michelon, Pride of Waltham, Reynolds Hole, Countess of Rosebery, Horace Vernet, Mdle. Montet (after the style of Mdle. G. Luizet), Duchesse de Morny, Francisca Kruger, Alfred Colomb, Dr. Andry, Niphotos, M. Vaillant, Her Majesty, Madame Cusin, and Duchess of Bedford. Mr. H. Merryweather, Southwell, Notts, was second, showing some very fine blooms, but less even in size than the first. Jean Soupert was especially striking in this stand, Pride of Reigate and Etienne Levet also good. For third place Messrs. J. & W. H. Burch, Rose-growers, Peterborough, were successful, showing Her Majesty, Eclair (very bright), Xavier Olibo, A. K. Williams, Maréchal Niel, and Comtesse de Nadailac in good style. Mr. F. Cant, Colchester, and Mr. J. C. Sheppard, Bedford, also showed creditably in this class.

In the open competition for eighteen Teas, Messrs. J. Burrell & Co. were again first with a splendid lot, the stand scarcely containing a defective bloom. Cornelia Koch (a very striking flower), Madame de Watteville, Madame Cusin, David Pradel, Madame Angèle Jacquier, Marie Guillot (in best form), Marie Van Houtte, Innocente Pirola, and Souvenir d'un Ami being all here well represented. Mr. F. Cant secured second place, and the Rev. W. H. Jackson of Stagsden Vicarage was third.

For twenty-four cut blooms, open to all amateurs, E. B. Lindsell, Esq., Bearton, Hitchin, well maintained his reputation, and secured first position, his finest flowers being Merveille de Lyon, Charles Lefebvre, Ulrich Brunner, Madame Victor Verdier, Maréchal Niel, François Michelon, Her Majesty, Abel Carrière, and Innocente Pirola. Mr. Lindsell's boxes were refreshingly cooled with ice. The Rev. W. H. Jackson was a formidable competitor, and came in close as second, his bloom of Baroness Rothschild comparing favourably with any bloom of Her Majesty in the Show. The latter, however, is by no means a despicable occupant of the Rose stage, but probably will be in finer form another year. The Rev. W. Langley, Narborough, was third in this class.

For twelve Teas and Noisettes, open to all amateurs, Dr. King, Madingley Vicarage, Cambridge, was first, having Madame Margottin, Etoile de Lyon, Princess of Wales, Souvenir d'Elise, Jeau Ducher, Madame de Watteville, and The Bride in fine form; the latter, however, as shown has a rather strongly tinted outline. Mr. Lindsell was second, and Mr. Jackson third. For twelve cut Roses, distinct, in the open class for amateurs, Mr. G. Moules of Hitchin was first; the Rev. W. H. Gall, Hitchin, second; and Mr. J. T. Green, Bletsoe, third.

In the open class for thirty-six bunches of hardy herbaceous or bulbous flowers Messrs. J. Burrell & Co. were first with a fine and well set-up collection, containing several of the best Liliams, including testaceum, pardalinum, Humboldti, and chalcedonicum; also the lovely Campanula pelviformis, and Pyrethrum Parthenium, "White Queen," a useful white flower. Mr. J. Sheppard was second, and Mrs. Horton third. Messrs. Burch also showed a very attractive stand of Rose W. A. Richardson not for competition. Amongst the successful exhibitors of Roses in the local classes the Rev. W. H. Jackson was first for twenty-four and twelve

blooms; and for nine flowers Mr. Quarry and Mr. Johnson, Bedford, were each first in separate classes.

Plants are not usually a strong feature at the Bedford Show, the prizes offered being small. Mr. G. Robinson, gardener to Frederick Howard, Esq., Abbey Close, Bedford, however, showed some well-grown specimens, securing first honours for a group; also for six foliage plants, six exotic and six hardy Ferns, and six well-grown Fuchsias. Mr. G. Vyne, gardener to C. Franklin, Esq., Bedford, coming first for very fine Coleus and Liliams. Mr. Galloway, gardener to Miss Rice Trevor, Bromhall Hall, led in Begonias, &c.; Mr. Musgrove, gardener to A. D. Chapman, Esq., Milton Ernest, came first for twelve plants for table decoration; and J. W. D. Harrison, Esq., Bedford, for six Pelargouiums.

Fruit was not strongly represented in competition. Mr. G. Allis, gardener to Major Shuttleworth, Old Warden Park, Beds, however, was first for six varieties, Pines excluded, showing some remarkably fine Buckland Sweetwater and Hamburgh Grapes, Melon, Peaches, Nectarines, and Strawberries; Mr. Galloway coming in a creditable and close second. For two bunches of black Grapes Mr. Allis was again first, and Mr. Galloway second, both with Black Hamburghs. For two bunches of white Grapes Mr. Allis was first with Buckland Sweetwater very fine in berry and bunch but wanting in finish. Mr. Robinson was second with smaller but well-ripened fruit of the same variety. For three dishes of Strawberries Mr. Allis was first; and Mr. Waller, gardener to Jas. Howard, Esq., Clapham Park, Bedford, was second. For a single dish of Strawberries Mr. G. Dyer, gardener to G. W. Repton, Esq., Odell Castle, came to the fore with fine fruit of Sir J. Paxton.

Messrs. Thomas Rivers & Son, Sawbridgeworth, showed, not for competition, a collection of fruit which was a source of much attraction, the Cherries looking especially captivating; Early Rivers, Black Hawk, Ludwig Bigarreau, and Monstrueuse de Mezel were the varieties shown, and in the finest condition; Dr. Hogg, Magdala, Princess of Wales, and Crimsou Galande Peaches; Newton, Goldoni (new and striking), Pique Apple, and Rivers' Orange Nectarines; Early Transparent Plums and English Oranges were also all worthily represented. This collection deservedly received the high commendation of the Judges.

Vegetables were in most of the classes well competed for, and, with the exception of Potatoes and roots, generally good. Peas were especially fine and well shown by Mr. Waller, gardener to James Howard, Esq. For a collection of twelve varieties of vegetables open to all amateurs in the county Mr. Waller was first, showing very good Peas, Mushrooms, Artichokes, Carrots, Tomatoes, French Beans, and Marrows. Mr. Robierson was second, Mr. Vyne third, and Mr. Musgrove fourth. In competition for the prizes offered in this class by Messrs. Sutton & Sons, the Royal Berkshire Seed Establishment, Reading, for six varieties of vegetables, Mr. Waller was again first, Mr. Musgrove second, and Mr. Robierson third. For collections and single dishes of Potatoes Mr. Waller was also first, as also for a very fine collection of Peas, including Duke of Albany, Laxton's Walton Hero, and a seedling, Progress, and Sutton's Reading Giant, in fine condition. For the single dish of twenty-four pods Mr. Waller took the lead, and was well first with wonderfully fine examples of a new seedling of Mr. Laxton's (since named Victorious). For the collection of six varieties of vegetables in competition for prizes offered by Messrs. Webb & Sons, Royal Seed Establishment, Wordsley, Stourbridge, Mr. Waller was also first, and Mr. Vyne second. Wild flowers and Grasses were largely shown, and in most instances carefully named and classed both in the fresh and dried states; and the judges at these shows have generally a heavy assize, the large number of children educated at Bedford usually providing ample competition; and although the season has been adverse, their duties on this occasion were by no means light.

A simple appliance for training plants was shown by Messrs. W. Day and Sons, Ironmongers, Bedford, and used by J. W. D. Harrison, Esq., of Bedford, on plants exhibited by him. Looped or indented rings made of copper wire of good strength were fixed around the pot under the rim, and to these the branches were tied down, and they seemed to answer their purpose admirably.

The continued success of this Show is largely due to the able efforts of Mr. H. Tebbs, the Honorary Secretary, who is a well-known adept at organisation in Bedford; and it is to be hoped that a financial loss will not be sustained by the Society, although the attendance was hardly equal to that of last year. The weather was, however, all that could be desired.

### HAWKHURST.—JULY 13TH.

THERE are few prettier spots than Hawkhurst in the highly favoured county of Kent, and very few better all-round displays of garden produce are brought together at its annual Show. The Society embraces a rather large district, is remarkably well managed, and receives good support from all classes in the neighbourhood. In spite of a generally bad season, the cottagers were yet able to stage excellent vegetables, in some instances even surpassing the exhibits of professional gardeners. One large tent was devoted to arts and manufactures, and local talent had various opportunities of asserting itself. This feature is well worthy of imitation by other societies in want of novel and attractive addition to their programme, and if they meet with success at all equal to that enjoyed at Hawkhurst they will have good cause to congratulate themselves upon the innovation.

Stove and greenhouse plants, considered as a local display, were highly creditable, and some of them would have taken good prizes at more pretentious exhibitions. For six flowering plants Mr. C. Nicholls, gardener to Mrs. Fisher, Hawkhurst, was well first, having good specimens of *Statiche profusa*, *Allamanda Hendersoni*, *Stephanotis floribunda*, *Kalosanthes coccinea*, *Bougainvillea glabra*, and *Erica Thompsoni*. Mr. J. Gilmour, gardener to the Right Hon. G. J. Goschen, Seacoxe Heath, Hawkhurst, was a good second. Mr. G. Rummery, gardener to Sir E. J. Hardinge, Bart., Fowler's Park, Hawkhurst, followed. For six plants of any description Mr. C. Nicholls was first, having well flowered *Anthurium Schertzerianum*, *Erica Aitoniana turgida*, *Kalosanthes coccinea*, and *Statiche*, fresh and good. Mr. J. Knapp, gardener to H. Maynard, Esq., Oakfield Lodge, Hawkhurst, was awarded the second prize. Mr. G. Rummery was a creditable third. Mr. Knapp received a first prize for four plants, *Cissus discolor*, *Bougainvillea glabra*, and *Vinca rosea* being most worthy of note.

There was quite a fine display of Fuchsias. Mr. J. Gilmour was easily



first for four plants, having fine pyramids, fresh and well flowered, of Rose of Castille, Arabella Improved, Lustre, and Wave of Life. They were two-year-old plants, the tallest being about 8 feet high and unusually proportionate. Mr. Nicholls had Lucy Mills, Lustre, and other sorts in good condition, and received the second prize, Mr. Rummy taking the third. Balsams were fairly well shown by several growers, Mr. Gilmour having the first prize for the most freely bloomed plants; Mr. L. Barnes, gardener to Col. Herschell, Collingwood, Hawkhurst, was a good second, and Mr. J. Knapp third. The last named had grandly flowered Gloxinias, and was awarded the first prize; and Mr. Gilmour was first and Mr. Barnes second for Cockscombs. Mr. Knapp was first for Zonal Pelargoniums, and also for Achimenes, the latter being capitally flowered, the other prizes going to Messrs. Gilmour and Nicholls.

Fine-foliage plants were not extensively shown. Mr. J. Gilmour was easily first for six specimens, these consisting of a fine *Phormium tenax variegatum*, *Acalypha musaica*, *Phoenix dactylifera*, *Chamerops australis*, *Lantana borbonica*, and *Pandanus Veitchi*. Mr. Nicholls was second, his collection including a prettily coloured plant of the now rarely seen *Hibiscus Cooperi*. Mr. Gilmour was first for six *Caladiums*, and Mr. Knapp second, such sorts as *Louis Duplessis*, *Prince of Teck*, *Belleymeri bicolor splendens*, and *Alfred Bleu* being very fine. Mr. Gilmour was also first for six very handsome pyramidal *Coleuses*, these consisting of *Pompador*, a pretty golden sport from the same, *The Queen*, *Pride of the Market*, *Mrs. Sherriff*, and *Mrs. Steddall*; Mr. Knapp was second. Mr. F. Dean, gardener to W. T. Neve, Esq., Osborne House, Cranbrook, was first for six Ferns, these including *Lygodium scandens*, *Gymnogramma chrysophylla*, *Davallia Mooreana*, and *Adiantum cuneatum* in a very healthy condition; Mr. Gilmour, who had *Adiantum Williamsi*, *Davallia Mooreana*, and other well-known kinds, very fresh and good, was a close second. Two groups of miscellaneous plants were in competition, Mr. Gilmour being well first for a very effective and tasteful arrangement, in which excellent *Celosias*, *Amaryllises*, feathery Palms, *Caladiums*, including the pretty little *argyrites* in quantity, *Clerodendron fallax* and *Gladioli The Bride* were effectively employed; Mr. C. Nicholls was second, he also having a light arrangement.

Fairly liberal prizes were offered for cut Roses, but these for the first time failed to attract growers from a distance. The best twenty-four blooms were shown by Mr. Gilmour, these including good *Duke of Edinburgh*, *Sultan of Zanzibar*, *Perle de Lyon*, *La France*, and *John Stuart Mill*; Mr. Nicholls was second, and Mr. John Collins, Hawkhurst, third. The best twelve varieties were staged by Captain H. S. Swiney, *The Limes*, *Hawkhurst*, the best of these being *Sir G. Wolseley*, *Duke of Edinburgh*, *Jean Ducher*, and *La France*. Mr. Barnes was second. There were two collections of twenty-four varieties of cut flowers, and both were very choice and beautiful. That staged by Mr. Nicholls, and which was awarded the first prize, contained several *Ericas*, *Oncidiums*, *Stanhopeas*, and other beautiful flowers. Mr. Gilmour was a close second, his stands being really the most attractive. Mr. W. Butler was first for twelve varieties of cut flowers, and Captain Swiney second. Mr. Gilmour was first for a beautiful collection of annuals, and also for Carnations.

Much less fruit was shown than usual. Mr. L. Barnes was easily first for black Grapes, having small but well-finished *Black Hamburg*, and Mr. W. Avis, Faircrouch, Wadhurst, was second with the same variety. Mr. L. Barnes had beautifully ripened *Buckland Sweetwater*, and was first in the class for white Grapes, Mr. Avis being second with the same variety. A special prize was awarded to Mr. L. Barnes for a collection of seven varieties of Grapes, these consisting of *Mrs. Pince*, *Golden Champion*, *Black Prince*, *Foster's Seedling*, *Black Hamburg*, *Buckland Sweetwater*, and *Mnscat*, all in good condition, the last-named being especially good. The same exhibitor was first for ten dishes of fruit; and with eight dishes Mr. J. Iggulden, gardener to the Rev. Canon Jeffreys, Hawkhurst, was well first, *Eleanor Strawberry* being his most noteworthy dish. Several good Melons were shown, Mr. Gilmour taking first for a scarlet-flesh sort, and was a very close second for a green-flesh, Mr. Avis being first in this case. Mr. J. Iggulden was third in each instance. Very fine *Negro Largo Figs* and good *Pine Apple Nectarines* were shown by Mr. Avis. Collections of vegetables were fairly numerous, and in two instances all the exhibits were nearly of equal merit. Mr. Knapp was first for ten varieties, having excellent *Tomatoes*, *Potatoes*, *Peas*, *Marrows*, &c.; Mr. Gilmour was second; and Mr. Barnes third, these also having fine vegetables. The best collection of eight dishes was staged by Mr. H. Oxford, Rolvenden, Mr. J. Iggulden being a creditable second. Messrs. Sutton & Sons offered prizes for six varieties of vegetables, and for these Mr. Rummy was first, and Mr. W. Butler second. There was better competition for Messrs. Carter & Co.'s prizes, these attracting some of the best vegetables in the Show. Mr. L. Barnes was easily first, having very fine *White Elephant Onions*, *Mont Blanc Cauliflowers*, *Nantes Horn Carrots*, *Stratagem Peas*, *Ashleaf Potatoes*, and *Dedham Favourite Tomatoes*; Mr. Gilmour was second, and Mr. H. Fincham third. A good brace of *Sir Garnet Wolseley* won Mr. Gilmour the first prize for Cucumbers; Mr. J. Barton being second, and Mr. Barnes third. All other kinds of vegetables in season were also extensively and well shown, were more plentiful and more superior in quality than might have been expected after so long a drought.

#### CHISWICK.—JULY 14TH.

THE Royal Horticultural Society's Garden at Chiswick presented an unusually gay appearance last Thursday, when, by permission of the Council, the Chiswick, Turnham Green, and District Horticultural Society held their annual exhibition there. The weather was most favourable, the entries numerous, and the quality of the exhibits highly satisfactory, constituting a show that for general merit is not surpassed by any in the suburbs of London. Ample proof has been afforded by the exhibitions held by the Society, that there is a great capacity for improvement in the district, as the advance each season has been very notable. A better site could not be obtained, and all that is needed is a larger attendance of visitors, with more liberal contributions to the subscription list, to render the Society an unqualified success. The Committee, with their energetic courteous Secretary, Mr. J. Fromow, deserve every encouragement, and they have good reason to be satisfied with the result of their efforts up to the present time.

Three large marquees were appropriated to the exhibits, one to groups of plants, a second to floral decorations, a third to cottagers' productions, and, in addition to these, the large vinery was filled with plants, vegetables, and fruit. The chief interest of the Show centred in the groups of plants competing for the Jubilee challenge cup, value 26 guineas. This valuable prize is presented by Mrs. S. A. Lee, and must be won three times, not necessarily in succession, the winner each time to have possession of the cup for the year, and is responsible for it during that time. It was offered for a group of plants arranged for effect in a space not exceeding 100 square feet, money prizes of £4, £3, £2, and £1 being also offered for the first, second, third, and fourth exhibitors. There were three competitors, all having good groups, but two were extremely meritorious, and so nearly equal that judging was not an enviable task. Ultimately, however, Mr. W. Brown, St. Mary's Grove Nursery, Richmond, won the great prize with a remarkably effective and tasteful group, comprising graceful Palms, *Draenas*, a few well coloured *Crotons*, a groundwork of *Caladium argyrites* and other varieties, with *Eulalia japonica variegata*, *Adiantums*, and an exquisitely neat margin of *Onychium japonicum*, *Panicum variegatum*, *Fittonia argyryneura*, and *Caladium argyrites*. The flowering plants were scarlet *Gladiolus*, at the back, *Lilium candidum*, *L. auratum*, *L. speciosum*, *L. longiflorum*, Carnations, *Tuberoses*, *Tuberous Begonias*, *Gloxinias*, *Odontoglossum vexillarium*, *O. crispum*, *Cyrtopodium barbatum*, a few blue English Irises, and *Clerodendron fallax*. There was a charming brightness and lightness about this group which won many admirers, and the margin was a perfect finish.

Messrs. Hooper & Co., Twickenham, were second also with an admirably arranged group, and these two contributions required very careful judging. It was quieter and more refined in tone than the first, but not quite so telling. *Tuberoses*, Carnations, Lilies, Orchids, *Gloxinias*, with *Begonias* and foliage plants were freely used, the margin consisting of *Panicum variegatum* alternate with *Isolepis gracilis* and *Cyrtopodium fulgida*. A large plant of *Lilium Martagon dalmaticum* in the centre had a rather unpleasant effect, and there was a slight suspicion of crowding at the sides that is rarely seen in the groups with which Mr. Bruckhaus has so frequently and deservedly won high honours. Messrs. W. Fromow & Sons, Sutton Court Nursery, were third with a bright contribution, in which *Crotons* were conspicuous, Orchids, *Gloxinias*, and other flowering plants being numerous.

Another silver cup, value 7 guineas, also presented by Mrs. S. A. Lee, was offered for a group of twenty-five plants in flower, in pots not exceeding 8 inches, arranged with Palms and Ferns, the second prize being the Royal Horticultural Society's silver medal. Mr. J. Prewett, Swiss Nursery, Hammersmith, was first, showing small plants of Orchids, and a central *Ixora* in a bed of *Adiantum cuneatum* and *gracillimum*, very simple and pleasing. E. H. Watts, Esq., Devonhurst (gardener, Mr. A. Wright), was second, his plants, being similarly arranged, but consisted of Lilies, *Begonias*, Orchids, *Gloxinias*, and *Hydrangeas*. For a group in a space of 60 feet Mr. A. Wright was also first with a bright and neat collection.

In the miscellaneous plant classes the following were the principal exhibitors:—Messrs. H. Little and F. G. Tautz were the prizetakers for six Orchids, both having good plants. With six flowering plants Mr. W. Bates, gardener to Mrs. Meek, Poulett Lodge, Twickenham, was first with grand specimens; Mr. Chadwick was second; and Mr. A. Wright third. Mr. Chadwick had the best six Ferns, and was also first with six foliage plants, followed by Mr. H. Davis, Fairlawn House Gardens, Chiswick. For six table plants shown, Mr. C. Waite was first; Mr. W. Bates was second; and Mr. Hudson was third; eight entries. *Pelargoniums*, *Tuberous Begonias*, *Cockscombs* (very fine from Mr. W. Bates), *Achimenes*, *Gloxinias*, *Caladiums*, and other plants, added both to the extent and beauty of the Show. The Royal Horticultural Society's silver Bankian medal for the best single specimen plant in the Show was awarded to Mr. Little for *Cattleya Gaskelliana* in excellent condition.

Floral decorations formed an interesting feature. With three bouquets Mr. R. Chard, Stoke Newington, was first with charming contributions, comprising a few *Pancretiums*, *Eucharis*, *Stephanotis*, *Gardenias*, white *Roses*, pale yellow Carnations, and three *Cattleya Mossia* flowers in two of them. The simple freedom of these bouquets gained the honours. Messrs. Perkins & Sons, Coventry, were second with three grand bouquets, perhaps a trifle too formal, chiefly composed of *Pancretium fragrans*, *Dendrobium Jamesianum*, *Odontoglossum crispum*, a few *Ixora* flowers, white *Lapagrias*, *Stephanotis*, *Hoyas*, *Caladium argyrites* leaves, pink *Rhododendrons*, *Ericas*, yellow and white *Roses*. Mr. W. Gardner, 127, Queen's Road, Baywater, was third, Miss Jolliffe Carnations, white Lilies, *Stephanotis*, white Lilies, Carnations, &c. For a stand of flowers Mrs. Chard was first, an elegant glass tube with three arms being filled with *Grasses*, *Marguerites*, *Coreopsis*, *Rhodanthes*, *Aquilegia chrysantha*, and white *Bouvardias*; the base consisting of golden *Aquilegia*, white Lilies, *Cattleyas*, white Lilies, a few *Coleus* leaves and Fern. Mrs. Hudson, Gunnerbury House Gardens, Acton, was second with a graceful stand in which *Humea* flowers were employed at the tops with *Rhodanthes*, and the base was formed of white *Water Lilies*, *Streptocarpus*, *Begonias*, &c. Miss S. A. Fromow was third with a bright and pretty stand. Mr. Hudson was first with buttonholes, followed by Mr. H. S. Hopkins, Chiswick, and Mr. H. Harling, gardener to W. E. Tautz, Esq., Sutton Lodge. Mr. C. Cowley, gardener to F. G. Tautz, Esq., Studley House, Hammersmith, was first with a pretty bouquet, composed of *Odontoglossum*, *Stephanotis*, *Epidendrum vitellinum*, and *Agapanthus* flowers. Mr. Chadwick, gardener to E. M. Nelson, Esq., was second; and Mr. Hopkins third.

For three stands of flowers Mr. J. R. Chard won the Duke of Devonshire's prize with light graceful stands, in which *Cattleyas*, *Lilium longiflorum*, *Aquilegia chrysantha*, and *Marguerites*. The tops were filled with *Aquilegia*, *Rhodanthes*, and *Grasses*. Mrs. Hudson was second with an effective tasteful arrangement, and Mr. J. Prewett was third. Cut flowers were also well shown by several exhibitors.

The prize offered by J. R. Starling, Esq., for the best hand-painted china or terra cotta vase, tile, or plate, the subject being flowers, fruit, or foliage, brought several competitors, but the honours were accorded to Mrs. Harry Turner, Langley, Bucks, for a terra-cot plate depicting a plant of *Odontoglossum crispum*.

Fruit was represented by several good exhibits. The first prize offered by Leopold de Rothschild, Esq., for a collection of six fruits, distinct kinds,



was well won by Mr. W. Bates, who had good white and black Grapes, Peaches, Nectarines, a capital Pine Apple, and a Melon. Mr. C. J. Waite, Esher, and Mr. Chadwick followed. With black Grapes, Mr. T. Osman, Ottershaw Park Gardens, Chertsey, was first with two capital bunches of Black Hamburgh, Mr. Milsom was second and Mr. A. Wright third. Mr. Osman was again first with white Grapes, good examples of Buckland Sweetwater, closely followed by Mr. W. Bates with Foster's Seedling, and Mr. J. Coombs for Muscat of Alexandria. Mr. Palmer was first with an excellent Melon, Hero of Lockinge, well netted and of good flavour; Mr. Hudson leading with two fine dishes of Cherries, Bigarreau Napoleon and Black Tartarian. Gooseberries, Currants, and other small fruits were shown in several classes.

Vegetables were shown in good numbers and fine condition. In the class for Messrs. Sutton & Sons' prizes for six varieties of vegetables, Mr. C. J. Waite, Glenhurst Gardens, Esher, took the lead with white Leviathan Onions, King of the Cauliflowers, Snowdrop Potatoes, Duke of Albany Peas, Early Gem Carrots, and good Tomatoes. Mr. C. G. rrod, gardener to J. K. Tindale, Esq., Oxford Lodge, Twickenham, was second; Mr. W. Palmer, gardener to W. F. Hume Dick, Esq., Thames Ditton, was third; and Mr. Chadwick fourth.

In Messrs. Carter and Co.'s class for six varieties of vegetables, Mr. C. J. Waite was again first with Sukreta Potatoes, Mont Blanc Cauliflowers, white Emperor Onions, Carter's Horn Carrots, Perfection Tomatoes, and Stratagem Peas. Mr. J. Stroud, Twickenham, was second, and Mr. J. Coombs, Mortlake, was third. In the Society's class the prizewinners were Mr. C. J. Waite, Mr. J. Coombs, and Mr. C. Garrod, in the order named. In the Potato class Mr. C. J. Waite was first with Sutton's Seedling, Beauty of Hebron, and Woodstock Kidney. Mr. Waite was also first with Peas, and Mr. Palmer with Tomatoes. Lady George Hamilton offered three prizes for the best collection of garden produce, which formed an interesting class. Mr. Chadwick won first honours with an excellent collection, followed by Messrs. A. Wright and Davis.

Non-competing exhibits were numerous. Mr. J. Roberts, Gunnerbury Park Gardens, had a basket of very fine Gloxinias edged with Panicum. Mr. J. Roberts also had an imposing group of flowers and fine-foliage plants. Mr. May, gardener to the Marquis of Bute, Chiswick House, showed large group of flowering and fine-foliage plants (highly commended). H. Little, Esq., The Barons, Twickenham (gardener, Mr. F. J. Hill), contributed a group of Orchids, not for competition, which comprised grand plants of *Cypripedium Lawrencianum* and *lambatum*, with *C. superciliosum*, *C. Day-anum*, *C. superbiens*, *Cattleyas*, *Laelia purpurata*, and *Brassavola Digbyana*. Messrs. C. Lee & Son, Hammersmith, contributed a large group of ornamental, foliage, and variegated shrubs (highly commended). The same firm had seven boxes of fine Rose blooms (highly commended). Mr. T. S. Ware, Tottenham, had a collection of hardy flowers (highly commended). Messrs. J. Veitch & Sons, Chelsea, had eight boxes of handsome Rose blooms (highly commended). Messrs. Hooper & Co. had a collection of fine Gloxinia blooms (highly commended). Messrs. J. Carter & Co., High Holborn, showed a large group of annuals (highly commended).

#### EAST MOULSEY.

EAST MOULSEY is the centre of a populous and fertile district in the neighbourhood of Hampton Court, and supports a horticultural society that has done much good among all classes in the neighbourhood who delight in the cultivation of flowers, fruit, and vegetables. The Society's Exhibition was held on the 13th inst. in the well-wooded grounds of Moulsey Court, the residence of F. Francis, Esq. As there are not many large specimen plant-growing establishments in the neighbourhood, the Committee wisely gave the best prizes for groups. The competition was good and the arrangements creditable to the exhibitors. In the large group class, Mr. Turner, gardener to F. Francis, Esq., was placed first with a cheerful association of healthy plants, amongst which double Petunias, Lilliums, and Gloxinias were well represented, with a fine central Palm. Mr. G. Masters, Walton Road, Moulsey, followed very closely indeed with a more generally artistic group, but a little light in the centre. Mr. G. Bailey was third, his plants being a little too closely packed. In the small group class the awards went respectively to Mr. Berridge, gardener to T. Andrews, Esq., for a very chaste arrangement; Mr. Peters, gardener to A. Keating, Esq., and Mr. Giles, gardener to O. Keene, Esq., for attractive collections. A class was provided for nine plants, the first prize being well won by Mr. Hunt, gardener to Sir Robert Carden, who staged a very fine *Cyathea medullaris*, also a good *Cycas* and *Bougainvillea*; he was followed by Messrs. Haskett, gardener to C. O'Hagan, Esq., and Turner. Mr. Hunt was first also for ornamental foliaged plants, Ferns, and Begonias. Gloxinias were very good indeed, the first prize falling to Mr. Hookings, gardener to Sir Henry Thompson, Messrs. Hunt and Turner closely following. Mr. Yeo, gardener to Miss Fitzroy, secured the leading prize for Zonal Pelargoniums with dwarf healthy floriferous plants, Mr. Vile being second, and Mr. Gower third with larger examples. Fuchsias were fresh, healthy, and well grown by Messrs. Peters, Gower, and Berridge, who were awarded the prizes in the order named. Mr. H. Long exhibited well in the amateurs' class, a white Oleander being specially admired.

Roses were on the whole rather small but fresh and bright, though the whole of the collections were not well staged. Messrs. Yeo, Sumpter, Bonine, and Goodhall were the successful exhibitors. Mr. Will Taylor staged good stands not for competition. Collections of hardy flowers for which Messrs. Yeo, Davis, and Hunt received prizes, were very good, and table decorations excellent.

Fruit was very well represented. Messrs. Hookings and Hunt taking the prizes for black Grapes, their positions being reversed with whites, the former Black Hamburghs, the latter Foster's Seedling, and all good. The only superior Melon staged was Hero of Lockinge by Mr. Turner. Small fruits, such as Currants, Raspberries, Gooseberries, Cherries, and Strawberries, were admirably shown both by gardeners and amateurs.

Vegetables were excellent, the prizes for eight dishes being won by Messrs. Hookings, Turner, and Davis with first-rate produce, and not less meritorious were the collections of six dishes with which Messrs. Yeo, Hunt, and Beaver were the successful exhibitors. Mr. Hookings had also a special and fine exhibit of Peas and Beans. The Duke of Albany was perhaps the finest Pea in the Show. Mr. Yeo staged the best six dishes of Potatoes we

have seen this year, the varieties being Lord Rosebery, red round; Snowdrop, Vicar of Laleham, Prime Minister, Prizetaker, and Reading Perfection. These won and well deserved the highest award, Messrs. Hookings and Turner following. Mr. Masters' prizes for vegetables were won by Messrs. Hunt, Beaver, and Gower. Mr. Hookings staging the best Cucumbers, Carter's Model.

The Show was well managed by Mr. H. Andrews, the Honorary Secretary, and Mr. G. Masters, and the Society is greatly indebted to the esteemed Vicar of the parish, the Rev. W. F. Reynolds, for his active co-operation in promoting its prosperity.

#### FAREHAM.

THE twenty-second annual Exhibition of the Fareham and South Hants Horticultural Society was held on the 13th inst. in a field adjoining the cricket ground, and was a success in quality. The plants were better than in past years, but there was a falling off in the fruit and vegetable classes, particularly amongst the cottagers, but the long-continued drought affects these exhibitors more than any others. The arrangements were excellent, and were as usual under the guidance of Mr. Harry Smith, the energetic Secretary. The principal plant class was that for eight stove and greenhouse specimens. Here Mr. E. Molyneux, gardener to W. H. Myers, Esq., Swanmore Park, was an easy first, his plants being large and clean, while his Crotons were magnificent in colour, the best being variegatus, 6 feet in diameter; Queen Victoria, a large plant, highly coloured. *Lantana horbonica*, a large fresh specimen; *Arca lutescens*, *Scaevola elegans*, and a freely flowered globular-shaped plant of *Bougainvillea glabra* were some of the most noteworthy.

Mr. W. Hawkins, gardener to W. Bishop, Esq., Swanwick, occupied the second place with much smaller specimens, but they were characterised by good health, the best being *Lantana horbonica*, *Cycas revoluta*, *Bougainvillea glabra*, and *Clerodendron Balfourianum*. Mr. Hawkins was first prizewinner for twelve specimens in flower and six foliage plants. In the former class *Anthurium Schertzerianum*, *Vinca rosea*, and *Oncidium sphacelatum* were the best, while in the latter class *Anthurium regale* was the most noteworthy. W. H. Deane, Esq., Fairfield took second prize. Equal first prizes were awarded to Mr. Hawkins and C. T. Thornton, Esq., for a group of miscellaneous plants arranged for effect, both having suitable material and good taste in arranging them. For a single specimen Mr. Molyneux staged a finely coloured *Croton angustifolius*, which gained the first prize, while a medium-sized *Lantana horbonica* took second honours for W. H. Deane, Esq. Mr. Hawkins had the best six Ferns, clear vigorous examples of good kinds.

Pelargoniums and Zonal Pelargoniums were best shown by Mr. Hawkins, while Mrs. Boyd had the best Coleus. For two bunches of black Grapes Mr. Molyneux was easily first, showing Black Hamburgh, medium-sized bunches, with large berries and well finished. Mr. Hawkins was second with larger bunches not quite so well coloured, while this latter exhibitor took first for two bunches of white Grapes with Foster's Seedling, rather green. Mr. Boyd second with much smaller bunches, but larger berries and better colour. Mr. C. J. Thornton staged splendid Cherries. Mr. Molyneux was the only exhibitor of one Melon, staging William Tillery in capital condition.

Major Ramsay, Ivery House, Fareham, was the only exhibitor of Roses, he staged a capital box of eighteen varieties and another of nine varieties, being fresh and of good form, A. K. Williams, Marie Baumann, Etienne Levet, Jean Ducher, Etoile de Lyon, Marie Rady, and Mrs. Laxton being the best, while in the nurserymen's class Messrs. Ewing & Co., Havant, were the only exhibitors of twenty-four varieties, which were in capital condition if not large; Pride of Waltham, Duke of Wellington, Sunset, Marquise de Castellane, Marechal Niel, and Countess of Oxford were the best, while the same firm staged a quantity not for competition, arranging them in threes. Merveille de Lyon, Reynolds Hole, Ulrich Brunner, and Comtesse d'Oxford were the most conspicuous.

For a box of cut flowers 3 feet by 2 feet Mrs. Boyd was the prizetaker with a choice assortment of both hot-house and hardy kinds. For twelve kinds of vegetables three exhibitors staged. Mr. Molyneux was an easy first with White Leviathan Onions, Nantes Horn Carrots, Globe Artichokes, Duke of Albany Peas, Trophy Tomatoes, and Long White Vegetable Marrows; the Rev. E. S. Prideaux, Brune, was second with a clean lot. Mr. Hawkins had the best dish of Tomatoes, a very fine one of Carter's Ruby. Messrs. Hawkins & Son, Fareham, staged a capital collection of small plants in a miscellaneous class.

#### ROYAL CALEDONIAN SOCIETY'S SUMMER SHOW.

HELD in conjunction with the Provincial Show of the National Rose Society, of which a detailed report appears above, this Exhibition was mainly noteworthy for the quantity and quality of the fruit and vegetables, both being largely in excess of what has been brought together at previous shows held at this date. The plants were few in number considering the large amount of floor space there is to cover in the Waverley Market, nor as a rule were they remarkable for size. Cut flowers were very poorly represented, setting the Roses aside of course.

An unfortunate *contretemps* occurred in the morning. The market gardeners, who only last year obtained in the highest Court of Appeal a decision favourable to their view that the Market had been built in the first place for their convenience, had not been consulted about the Show being held in their market, and they pushed their rights to the utmost extremity, refusing to leave the Market until at ten in the forenoon the market for the day was over.

Coming now to the prize list the more noteworthy features are noted below.

#### GARDENERS' AND AMATEURS' CLASSES.—PLANTS.

Class 1, table of plants, 20 feet by 5 feet, for effect. Three very pretty and effective groups were staged. The first prize was awarded to Mr. Grossart, Canaan Lane, Edinburgh, for a very light and pleasing arrangement. Mr. R. Cockburn, gardener to H. H. Norris, Esq., Colthridge Hall, second with an arrangement specially rich in Orchids, but sadly wanting in that lightness which is so effective; and third Mr. J. Donaldson, gardener to H. E. Moss, Esq., Murrayfield.

For six stove or greenhouse plants, in flower, distinct, Mr. J. Patterson,

Millbank, was easily first, having among other plants a good *Dracophyllum gracile*, *Erica Paxtoniana*, and *Clerodendron Balfourianum*; second, Mr. Ball, Canaan House, Edinburgh. With foliage plants, distinct species, there were three entries in this class, Mr. Grossart obtaining first, a good *Kentia Forsteriana*, *Croton Evansianus*, being the most noteworthy plants; Mr. W. Bennett, Hanley Lodge, Corstorphine, second. Mr. McKinnon, gardener to Viscount Melville, Melville Castle, took first for three foliage plants, a good *Dasyliion* being worthy of note; Mr. Grieve, gardener to Miss Falconer, Falcon Hall, showing the best *Cycas*.

There was nothing very remarkable among the Orchids. For four Orchids, distinct species, there were two entries, Mr. Grossart being first with two *Cattleyas*, *Cypripedium Lawrencianum* and *Phalenopsis amabilis*. Mr. A. Findlay, gardener to Jas. McKelvie, Esq., 14, Osborne Terrace, second with *Vanda suavis*, *V. limbata*, *Dendrobium suavisissimum*, and *Epidendrum vitellinum*. For two Orchids, distinct species, Mr. John Patterson, Millbank, was first, and for one Orchid, Mr. McIntyre, The Glen, Innerleithen, was first with a good piece of *Odontoglossum vexillarium*, Mr. R. Cockburn being second with a good plant of *Cattleya Mossiae*. Of four Cape Heaths, distinct varieties, Mr. John Patterson was the only exhibitor of these, and he took first prize with good examples of *Ericas tricolor* *Wilsoni*, *Vernoni*, *Aitoniana*, and *jubata rubra*. The same exhibitor was first for one Heath, Mr. McKinnon being second.

Ferns were not numerous, but what there were were good. For four exotic Ferns, distinct species, exclusive of *Adiantums* and *Gleichenias*, Mr. Grossart was first, staging a very large example of *Microlepia hirta cristata*, *Phlebodium aureum*, *Davallia Fijiensis plumosa*, and *Davallia Mooreana*. Mr. J. Forbes, gardener to P. Neil Fraser, Esq., Murrayfield, was a very good second, his plants being equally fresh and well grown, but of a smaller size; Mr. McKinnon, Melville Castle, third. Mr. Grossart also was first for three *Adiantums*. For eight British Ferns some remarkable specimens were exhibited by Mr. John Cumming, gardener to Dr. Caton, St. Rogue; especially beautiful and well grown were the examples of *Athyrium Filix-fœmina Victoriae*, *A. todeoides* a most lovely species, and *A. pulcherrimum*. Mr. John Leyden, White Hill, in the second prize lot had also some good examples. In the ten dwarf species, for which Mr. Anderson, Pilrig Buildings, Edinburgh, was awarded the first prize, were healthy little plants of *Asplenium septentrionale*, *A. germanicum*, and *Blechnum*. Mr. John Cumming had the best *Pelargoniums* of the decorative section, the best *Zonals* being staged by Miss Dickson, Morelands, Mr. Patterson the finest *Caladiums*, Mr. Grossart the best *Crotons* and *Dracenas*.

#### NURSERYMEN'S CLASSES.

PLANTS.—The chief prize offered to nurserymen was for a table of plants, 40 feet by 10 feet, for effect. In this class there was only one entry. A very fine table of plants was put up by Messrs. R. B. Laird & Sons, to which the first prize was awarded. The principal plants were well coloured *Crotons* and *Dracenas*, the groundwork being made up of Maidenhair Ferns, with an edging of *Ficus repens*, *Panicum*, *Caladium argyrites*, and other varieties with small leaves. The prizes for twelve *Coniferae* were divided between the Lawson Company, and Messrs. Dicksons & Sons, Edinburgh, the former receiving the first, and the latter the second prize. Messrs. R. B. Laird & Sons had the best Tree Ferns, Palms, six *Dracenas*, twelve table plants, and also table plants in flower. For a collection of alpine and herbaceous plants in flower, not less than fifty distinct species, Mr. Robertson, Munro, Portobello, was the only exhibitor, and obtained the first prize for a very large collection of the newer and older sorts. Among the many things exhibited was a plant of a double *Matricaria*, named Snowflake, a decided improvement on the commoner form, a plant of which was also staged. Messrs. R. B. Laird & Sons were the sole entrants for a collection of cut flowers of stove and greenhouse plants, and were awarded first prize for a meritorious stand. Mr. A. Irvine, Tighnabnich, was first, and Mr. Sutherland second respectively for twenty-four Show and twenty-four Fancy Pansies, the blooms being in each case fresh and large. Messrs. R. B. Laird & Sons had the best *Violas* in bunches, and Messrs. J. Cocker and Sons, Aberdeen, the bunch of Pansies.

CLASS 3.—FRUIT (OPEN TO ALL).—For a collection of eight dishes of fruit, two dishes of Grapes, and one dish of each other kind, first £4, second £2, and third £1, were offered as prizes. There were five collections staged, the first and second prize lots being very good. The first prize was awarded to Mr. McIndoe, Hutton Hall, Guisborough, who showed very fine full bunches of Black Hamburg Grapes, Duchess of Buccleuch Grape, Smooth-leaved Cayenne Pine Apple, Negro Largo Figs, Best of All Melon, Royal George Peaches, Pitmaston Orange Nectarine, and Jefferson Plums. Mr. A. Young, gardener to the Marquis of Breadalbane, Taymouth Castle, was a good second, showing fine Alicante Grapes, James Veitch Strawberries of enormous size, and very good Peaches and Strawberries; Mr. McIntyre, gardener to Sir Charles Tennant, The Glen, Peebleshire, third with fairly good Grapes, very good Pine Apples, &c. Mr. McKelvie, Broxmouth Park, Dunbar, showed good clusters of Muscat of Alexandria in the collection he staged. Five Pine Apples were shown, the best being an extra fine Queen from Mr. McIntyre; Mr. McIndoe second with a good example of Charlotte Rothschild; and Mr. Morrison, Archerfield, Drem, third. In the class for four bunches Grapes, two black and two white, there were five exhibitors. Mr. McHattie, gardener to the Marquis of Lothian, Newhattle Abbey, Dalkeith, was first with fairly well ripened clusters of Muscat of Alexandria, and large and fine Black Hamburg of 4 to 6 lbs. each; Mr. McIndoe second, and Mr. James Hogarth, Stranraer, third. Mr. McHattie was again first for two bunches Black Hamburg Grapes in a well filled class of ten competitors. The bunches were well finished, large in berry, and of about 3 lbs. weight each. Mr. McKinnon Melville Castle, second, and Mr. Hogarth third. For two bunches of a black variety, Mr. McIndoe was first with good Madresfield Court in fine condition; Mr. McIntyre, Woodside, Darlington, second with Alnwick Seedling, and Mr. McKinnon third with Madresfield Court. Two, white, any variety.—First, J. W. Machattie, Newbattle, with very fine Muscat of Alexandria; second, Mr. W. Wilson, Galashiels, with fairly good Buckland Sweetwater; and third, Mr. P. McTavish, Airthrey Castle, Stirling, with Muscat of Alexandria. For six Peaches, eleven lots shown, Mr. McKinnon was first with large and fine Royal George; Mr. McHattie second with nearly as fine Early York. There were eight dishes of Nectarines, Mr.

McHattie having extra finely coloured and large examples of Lord Napier, and Mr. Young smaller but fine Elruge. Mr. McIntyre with fine Brown Turkey Figs had first for these, Mr. McIndoe second with good Negro Largo. The best Melon in a class of ten fruits was Best of All from Mr. Melville, Elliston Gardens, St. Boswells; Mr. McIndoe second with same sort. The best basket of Strawberries were President, from Mr. P. Melville, Fullerton House, Ayrshire; James Veitch the variety to which the second prize was awarded. Mr. Dow, Newbyth, Prestonkirk, for four dishes Strawberries took first place with fairly good fruit of President and Marguerite, and large Duke of Edinburgh and Garibaldi.

CLASS 4.—VEGETABLES (OPEN TO ALL).—There was an extra large number of vegetables shown, and considering the nature of the season through which gardeners have passed, the quality was certainly of a generally high order. For the collection of vegetables, six distinct kinds, four prizes presented by Messrs. Sutton & Sons, Reading and London, there were ten entries. Mr. McIndoe secured the first prize with a capital collection, in which Prodigy Peas, Veitch's Early Pink Celery, Hackwood Park Prolific Tomato were very good, Onions, Cauliflowers, and Vegetable Marrows being the other sorts. Mr. McKelvie, Broxmouth Park, Dunbar, was second, and Mr. King, Dalzell House, Motherwell, third. Mr. McIndoe was also first in the class for a dish of twelve Tomatoes, showing very fine Hackwood Park Prolific. In a class where ten exhibitors staged, Mr. Bowman, Pittendreich, Lasswade, had the best Cucumber, a fresh brace of Telegraph. The other more noteworthy examples of vegetable culture were to be found in the classes devoted to Cauliflowers, Peas, Potatoes, Lettuces, and Early Horn Carrots, all of which were largely and well shown.

Among the miscellaneous exhibits the undernoted were the more noteworthy:—Messrs. Ireland & Thomson, Craigleith Nurseries, Edinburgh, contributed a small table of fine-foliage plants, Orchids, &c. Their seedling *Crotons* were especially noticeable, one named Sunray, with long arching foliage, bold habit, and of a yellowish orange colour, and Newmanni, with medium sized twisted foliage and of a light orange-red tint being especially fine. Messrs. J. Methven & Sons, Leith Walk Nurseries, Edinburgh, filled one of the large central groups with a mixed group of fine-foliage and flowering plants, consisting mainly of graceful Palms, well coloured *Crotons*, and decorative *Pelargoniums*. From the Lawson Seed and Nursery Company came a group of *Coniferous* plants and shrubs; Messrs. Dickson and Co., Hanover Street, contributing a group of the same class of plants. Messrs. Thomson & Sons, Clovenfords, Galashiels, exhibited a curious form of *Cattleya Gaskelliana*, to which they have given the specific name of *Striata*, from the two lower sepals having the identical appearance of the lip halved up the centre. Messrs. Dobbie & Co., Rothesay, exhibited examples of their specialities, African Marigolds being large and fine in quality. Several dozen blooms of Pansies were also shown, and some blooms of new fancy *Violas* not yet in commerce. Of these we can highly recommend Dawn of Day, Queen of Scots, Goldfinch, and Admiration, especially the two latter, as being most interesting novelties. Mr. Irvine, nurseryman, Jedburgh, staged very fine *Delphinium* varieties of his own raising. Of these John Duff, Joseph Smith, Nellie Irvine, A. Brownlee, R. Cairns, Annie Duff, The Marquis, and Samuel Bigham were the most distinct and good. Mrs. Brodie Sherriff, Portobello, showed a group of pottery, including some handsome garden vases and flower pots, the latter of fine workmanship and apparently much harder than the pots usually produced in potteries in the east of Scotland.

It only remains to be noted that the Council of the Royal Caledonian Horticultural Society entertained at dinner the officials, Judges, and some exhibitors of the two societies, at which Lord Provost Clark presided.

#### NOTES ON BULBS.

WHEN notions become firmly established it is very difficult to remove them, or convince cultivators that they are wrong, even by facts that are the outcome of practical experience. Perhaps no erroneous idea is more prevalent than the one that Dutch Hyacinths and other bulbous plants used for flowering in pots during the spring are not worth the labour and trouble of planting after they have done duty indoors. It would be difficult to trace the origin of such an idea, or the reason that has led to such a general opinion, but it is easy to prove that it has no foundation in fact, and is more than likely due to inexperience in the culture of bulbs. In a few soils Hyacinths, Tulips, Narcissus, and others may degenerate year by year, but in the majority they increase in numbers, size, and strength until they will yield flowers that cannot be surpassed by the second-class roots imported annually, or what may be known as first-class bedding roots. To attempt to plant out Roman Hyacinths, Duc Van Thol Tulips, Paper White, and Double Roman Narcissus that can be purchased at such a cheap rate would be a waste of time and labour. If they could be planted out direct from the forcing house such a step might be taken, but the necessary preservation needed to develop their growth and harden it to withstand the trying weather of early spring would prove a severe tax upon those with limited house or frame room at disposal for plant cultivation. With very early forced bulbs our experience has led us to the conclusion that the best course to pursue with them is to convey them to the rubbish heap directly they have flowered.

There are, however, tens of thousands of bulbs that are not forced, as they are allowed to come forward gradually and naturally in windows, greenhouses, cold frames, and similar positions. The majority of growers have bulbs of one sort or another in this condition, and if they are preserved after flowering as will be detailed they will with certainty increase in numbers and yield very fine spikes. The greenhouse is frequently robbed to ornament the dinner table and dwelling-room when the flowers could be gathered from outside beds and borders if care and a little forethought were exercised.

When the bulbs have been brought into flower under moderately cool conditions, a few days, or a week at most, in a cold frame is ample to harden them sufficiently to stand in a sheltered corner outside. From



this point two courses are open—that is, either to retain them in pots until the foliage dies, or to plant them out in the position they are intended to occupy. Wherever they are planted they should be left undisturbed for some years; when they will pay abundantly for the first trouble bestowed upon them. If the first plan is adopted they entail considerable labour in keeping them liberally supplied with water, or instead of thorough development their growth is prematurely brought to a standstill. This method is very frequently followed, so as to enable the cultivator, after the growth has ripened off naturally, to shake away the soil from the bulbs, and spread them out in the sun to dry and harden. It is contended that such measures are necessary, but the least labour and trouble is occasioned by the last method, and we have found that the bulbs do as well, if not better, the following season than when subjected to the artificial drying process. The better plan decidedly is to plant them out directly they have been well hardened, and then they complete their growth, and the foliage is ripened under natural conditions.

Failure may in many instances be traced to planting the bulbs in shrubby and other borders in soil that has become exhausted by the roots of other trees. Hyacinths, Tulips, Narcissus and other bulbs can no more be expected to thrive in unfertile soil than any other plant or tree, and yet such positions are frequently accorded them. Well developed growth and fine spikes of bloom cannot be produced from such positions, and under such circumstances we should not be surprised at them degenerating rapidly. They will do, however, on borders overshadowed by forest trees, provided the ground is liberally supplied with food. We have a border planted three or four years ago, and although the spikes are large enough for cutting purposes—in fact they are more useful than the larger ones—they will not compare with those grown in open positions and in good soil away from the roots of large trees.

The ground should be well dug and liberally manured as the work of planting proceeds; if this is done they will need no further care for two or three years, without Mignonette or other plants are grown on the border during the summer. In this case—and plants of this description will do no harm after the plants are cleared off in autumn—the borders should receive a dressing of short manure in a fresh state. This should be forked into the surface, so that rains will wash the juices down to the roots ready for them when they commence activity. The bulbs will soon show their appreciation of such treatment.

The first season they may prove somewhat disappointing, and here no doubt is one reason why they have been regarded as useless after the first season. The nearer perfection the bulbs have been produced previous to importation the more certain are they to come small, for they frequently divide into a number of small bulbs, while many of the bedding ones will grow for a season before they do so to any extent. After the bulbs divide into a number, which they do rapidly when planted out without any artificial treatment, the same as practised in Holland, and attain their full development, that fine spikes are produced. A bed planted with bulbs that have flowered in pots, especially of Hyacinths, are certain to produce spikes of nearly every size. Ten years ago we planted out a bulb of Grand Lilas; for two years it remained a single bulb and produced one spike only each year; it has now increased to thirteen, and eight of them have flowered, some of the spikes being unsurpassed by any of the bedding Hyacinths we purchased last autumn. When Hyacinths are grown three or four in a pot they should be planted out without division, for any attempt to divide them before their growth has been matured is certain to check them severely by the wholesale destruction of their roots. In planting be careful to place the bulbs at least 2 inches below the surface of the soil, or a little more, then the fork can be used without fear of damaging them.

Although we grow none in glasses we are certain that they also will repay for the trouble of planting in outside borders. A lady who only grows Hyacinths in glasses in the windows of her house was advised to plant them out after flowering, and her little flower beds are gay every year with the old bulbs that thousands would have thrown away as useless. When old bulbs are preserved they are often kept out of the ground too long, and I would rather plant them in July or August than leave them till November or December.—W. B.



#### HARDY FRUIT GARDEN.

**EARLY STRAWBERRIES.**—Where space can be afforded on the sheltered wall borders it is there the earliest Strawberries should be grown. Young or one-year-old plants are the best, these invariably producing the earliest and usually the finest fruit, without unduly robbing the fruit borders. Being cleared of fruit early, plenty of strong runners soon follow, and the required number for planting, both on the warm borders and also on the open ground, ought at once to be layered into 3-inch pots. If properly attended to the runners will soon fill the pots with roots, and before they are badly root-bound ought to be finally planted out. Supposing they are put out in succession to early Potatoes,

Cauliflowers, or Peas, for all of which the ground was well manured, it is yet advisable to fork in, not too deeply, another dressing of solid manure. There is not much danger of the plants forming too much foliage in these hot positions, especially if the precaution of well trampling the ground is taken. If planted in succession to Tripoli Onions we neither apply manure nor dig the ground, but merely draw drills, saturate these with liquid manure, and plant as soon as the ground can be worked. It being unwise, for several reasons, to leave the plants on the ground for a second season, they may be planted in rows 18 inches apart and 15 inches apart in the rows. They ought to be in a moist state when put out, be well and firmly planted, and receive good attention subsequently. Thus treated they will form large crowns and yield very profitable early crops the following season. Many proprietors of gardens prefer to gather the fruit for themselves, in which case a long row ought to be planted alongside the principal sunny walks. They succeed admirably in such positions, especially if there are no Box edgings to interfere with them, and the fruit is of easy access, there being then no need to trample on and spoil one half to get at the other half of the crop. Black Prince is yet the earliest sort we have, and on some soils produces extra heavy crops of fair-sized fruit. Another good old variety, Keens' Seedling, still holds its own in numerous gardens, and is gradually finding its way back into gardens from which it has been banished for a time. Vicomtesse Hericart de Thury, although excellent in pots, is not so profitable in the open, being neither early nor of a taking size. Both King of the Earlies and Pauline may well be given a trial, and room should certainly be found for the invaluable Sir Joseph Paxton. These warm border plants are also the best for furnishing a good supply of strong runners for forcing.

#### FRUIT FORCING.

**PEACHES AND NECTARINES.**—*Early-forced Trees.*—Those which were started from early December to the new year will, whether the varieties are very early, as Alexander, Waterloo, and Early Beatrice, or such as Hale's Early, Early Alfred, A Bee, and Royal George, for some time have been cleared of their fruit. They have had the wood on which the fruit was borne removed, if not extension, also any superfluous growths, so that those retained can have light and air, the foliage being fully exposed to the influences essential to forming and perfecting the fruit buds and the thorough maturity of the wood, which is encouraged by clean foliage and proper supplies of nutriment. The trees, therefore, must be syringed—cleansed of insects, if necessary, by the prompt application of an approved insecticide, and supplied with water, or in the case of weakly trees liquid manure at the roots. Mulehng will also tend to keep the roots active at the surface, and prevent the premature ripening of the foliage. The buds will be sufficiently plumped and the wood sufficiently matured to allow the roof lights being removed, which should not be further delayed, if not already done. This is a commendable practice, not the least of its advantages being the thorough moistening of the border by the autumn rains.

*Succession Houses.*—Trees that were started in February have the fruit ripe, and some are still ripening, the fruit being later than usual on account of the cold that prevailed in the early summer months, but it has been well worth waiting for—we never remember having finer, particularly of Royal George, its freer and finer form Stirling Castle being superb, and Grosse Mignonne, whilst Lord Napier Nectarine and Elruge deserve special note. It is clear that the improvement, both in size and quality, is due to their having had more time than they would have had if the early summer months had been warmer and sunnier, but we attribute much of the increased value of the crop to having fed the trees with the drainings of the house. Ours is a large tank, and receives the whole waste of a large establishment. We give it undiluted, and the smell is anything but unpleasant. As the fruit is cleared off the trees cut out the wood that has borne fruit, and thin the growths where too close, or where they are so close that the foliage cannot have exposure to light and air; cleanse the foliage by means of the syringe or engine with water of dust and red spider or other insect pests, if necessary using an insecticide. Keep the borders thoroughly moist, feeding if the trees have carried heavy crops, are at all weakly, or do not plump the bloom buds. Stop all laterals to one joint, or allow a little lateral extension if the trees have the buds in an advanced state, preventing premature ripening of the foliage by continuing the root action with at the same time growth on which to expend it without danger of forcing the principal buds into growth. When the buds are well formed, the fruit having been cleared from the trees, remove the roof lights. The exposure to rains and dew has an invigorating effect.

*Trees Swelling their Fruit.*—This is the case with those started in the middle of March. The fruit has stowed satisfactorily, as it will when three conditions are observed—viz., to have a border composed of rather strong loam with some clay or marl in it, so as to afford potash, old mortar rubbish or chalk to supply calcareous matter, good drainage, neither too wide nor too deep borders—2 feet is plenty as regards depth, and half the width the trees have of trellis, duly watered and fed from the surface; the shoots thinly trained; no overcropping or neglect of thinning in the early stages, and a genial atmosphere so as to insure steady progressive growth. The leaves should be drawn aside, and the fruit raised by means of laths across the trees, so that the apex will be to the light. Water the border both inside and outside with liquid manure, and keep the surface mulehed with rather lumpy manure. Avoid a close fine surface likely to form a soapy mass and exclude air. Ventilate early, in fact leave a little air on all night, syringing by 7 A.M., and through the early part of the day ventilate freely. When the sun



loses power in the afternoon begin to reduce the ventilation and raise the temperature to 85° or 90° about 4 P.M., with a good syringing and damping of surfaces, but it must be done with judgment, for when the water hangs for any length of time on the fruit during the last swelling it is liable to damage the skin, causing it to crack, or, if not that, it may give the fruit a musty flavour, therefore have the fruit dry before night-fall, and when the day is likely to be dull omit the morning syringing. Directly the fruit commences ripening cease syringing, but afford air moisture by damping available surfaces, especially the border whenever it becomes dry, ventilating rather freely, enough being left at night to insure a circulation of air.

**Late Houses.**—The fruit in these has stood well, but it is later than usual, in fact there will be little need to retard the fruit by having recourse to very abundant night ventilation. In order to assist the swelling observe the conditions laid down in the preceding paragraph. If wanted to accelerate the ripening ventilate rather freely in the early part of the day and up to one o'clock, then keep the heat obtained by reducing the ventilation so as to secure 80° to 85°, and at about 4 P.M. close, syringing well, and no harm will come if the temperature rise to 90° or 95°, ventilating a little about six o'clock so as to let the pent up moisture escape, and the temperature gradually cool down. Keep the shoots tied down as they advance, allowing no more than are necessary for next year's fruiting, or for furnishing the trees, let all have space for development—the full exposure of the foliage to light and air. Keep laterals stopped to one leaf, also retain growth to attract the sap to the fruit. If there are any gross shoots which push laterals from the leaf buds out them back to where the buds remain intact, or, if likely to disarrange the equilibrium of the trees—the equalisation of the sap—cut them out altogether. They only tend to promote gumming, imperfect setting, and certain casting of the fruit in stoning. Draw the leaves away from the fruit, raise it from the under side of the trellis, let it have as much light and air as possible, the sun acting directly on the apex. Peaches are no good unless coloured, the flavour corresponding thereto, other conditions being favourable.

**Unheated Houses or Cases.**—Our trees have the fruit stoning and taking the last swelling. The border is supplied with liquid from the tank receiving the house drainings, it being run directly from the liquid manure cart on the border by means of hose and wood troughs. The foliage assumes a dark glossy hue, and the fruit swells kindly, it being disposed so that it has light and air from all points as far as practicable by drawing the leaves aside, and raising it by means of laths across and secured to the trellis to the front. Secure the growths to the trellis as they advance, being careful to allow space in the trees for the swelling of the fruit. Keep the growths thin, every shoot having space for full exposure to light and air. Syringe about 7 P.M.; the house having a little ventilation constantly, increase the ventilation with the advancing temperature, contriving to have it full at 75°, or if it is wanted to accelerate the ripening keep through the day at 80° to 85°, but always with ventilation, and close sufficiently early to maintain that temperature, but not to raise it above 90°. Syringe again in the afternoon about 5 P.M. We have not a trace of red spider or insects of any kind, which we attribute to the use of the house sewage and syringing. Timely thinning increases the size of the fruits retained, therefore thin finally as soon as the stoning is completed. One Peach to every square foot is ample, also for the large Nectarines. The reason Nectarines usually are smaller than Peaches is because they are left much closer. In small fruit we have twice the weight of stone at a great sacrifice of flesh, and in appearance and quality there is no comparison of the two fruits.

**FIGS.—Second Crops.**—The fruit of trees started about the new year or before will have the second crop in an advanced state, and it must be thinned if not already done, reserving that at the base of the growths, which as a rule swells and finishes better than that at the points. This crop must not tax the energies of the trees too severely if they are expected to afford early fruit next season. Attend regularly to training and stopping the shoots. Train thinly, and allow plenty of space in the ties for the shoots to swell, stopping side growths at about the fifth leaf, but do not seek these spur growths to an extent likely to cause crowding. Afford water copiously through a good surface mulching of short manure. We have tried many sorts, but find none surpasses horse droppings. They are light, let in air, and contain nutriment that is given out for the benefit of the foliage and for washing into the soil. Water or liquid manure will be required according to the extent of the rooting area. The trees in narrow borders may need it every day, those of larger area corresponding thereto. They can hardly have too much water in hot weather, always provided the border is formed of sound material and the roots are active so as to lay hold of it, and there is drainage to carry off superfluity beyond the soil's retentive power. Syringe twice a day forcibly to dislodge red spider, but with proper feeding and attention there will be little need for insecticides, only nothing seems to prevent scale, therefore remove it with a brush and a soapy solution. Figs like abundance of air, they also delight in heat and light. Admit a little air constantly, increase it early, close early with plenty of moisture, and the fruit will swell to a good size, then a circulation of air constantly will enable the cultivator to produce Figs in perfection. Considering that Figs are so wholesome and nutritious it is remarkable they are not more generally grown.

**Fig Trees in Pots for Early Forcing.**—Syringe at least once a day, in hot weather twice, affording liquid manure at the roots and pinching to induce a neat habit in young plants with fruitfulness. Stopping must be regulated by the vigour of the plants and varieties. Vigorous growers

will need to be more closely pinched than those of moderate growth. It is important that the trees have plenty of light, are not crowded, and are well ventilated, to solidify the growth as it is made.

#### PLANT HOUSES.

**Mignonette.**—The whole stock intended to be trained on standard and pyramidal trellises should be placed in their largest pots. At the same time each plant should be given the trellis upon which it is to be trained. In the case of pyramids secure the shoots at the base, in order to furnish it thoroughly, for the uppermost portion of the trellis can be readily filled. If the plants have been purposely prepared according to previous directions, they will have plenty of shoots to reach the trellis in various directions, not only at the base, but more than half way up. Those intended for standards should have the branches evenly disposed over the trellis, training them towards the outer edge until they reach that position. Grow the plants under glass where they can be given light shade from the burning rays of the sun, plenty of air, and a moist bottom for the pots to stand upon. Hot dry atmospheric conditions must be avoided, or the shoots assume a woody appearance and fail to grow strongly. To insure well-furnished plants that will produce large spikes of bloom, they must be kept growing luxuriantly, but not forced out weakly by shading. Plenty of moisture should be maintained about the plants by frequently damping the floor and stage. The plants may with advantage have their foliage syringed twice daily. Water carefully after potting until the roots are working freely, but never allow the plants to suffer by an insufficient supply. A number of 5-inch pots may now be filled with three parts fibry loam to one of leaf mould, manure, and sand. Sow the seed evenly on the surface and cover it lightly. Give a good watering, and stand the pots in a cold frame and shaded from the sun until germination has taken place. They should then be gradually exposed until they gain strength, and are then grown in a light position outside, where they can be partially shaded from strong sunshine.

**Rhodanthes.**—Those grown outside in pots must be freely watered and liberally syringed, for if neglected in these respects they are liable to be attacked at this season by red spider, which quickly plays sad havoc with their foliage, and spoils them for decorative purposes. Another supply of plants may be raised by sowing seed in a few 5-inch pots filled with rich soil. Press the soil moderately firm to insure a dwarf compact growth, and only just cover the seed. Place the pots in a cold frame until the seed has germinated, then stand or plunge them outside. Plants raised now will prove invaluable for the conservatory after the middle of October.

**Heliotropes.**—Plants that have been grown to form standards or pyramids may now be plunged outside if they have been thoroughly hardened. All flowers must be removed and the shoots pinched freely, so that the heads, in the case of standards, are compact and well furnished instead of being straggling and loose, which is the result of negligence. The framework of pyramids must also be well furnished with sturdy growths, so that a mass of flowers may be expected. If covered with a few long shoots the plants cannot produce half the flowers, or produce the same beautiful effect as those covered with shoots about 2 inches in length when housed in autumn. Dwarf bushy plants in 2 and 3-inch pots with three or four shoots may now be placed in 5-inch pots and plunged outside. Pinch any shoots that take the lead, so that these plants will be dwarf, bushy, and well ripened when they are housed in September. Plants prepared on this principle will flower profusely during November and the following month if they are kept in a temperature of 55° to 60°.

**Chrysanthemums.**—A number should now be rooted in 3 and 5-inch pots. Insert all the large-flowering kinds singly in the former, and free-flowering Pompon kinds in the latter; these should be inserted five or six in each pot. Place the pots in a cold frame and shade them from the sun until the cuttings are rooted, and then grow the latter in a sunny position outside.

**Stocks.**—Sow seed in boxes of Ten Weeks and Intermediate Stocks for flowering in pots inside. Princess Alice is an early flowering white variety, invaluable for this purpose. Sow the seed in boxes, and place them in a cold frame until germination has taken place, when the boxes can be stood outside until the plants are large enough for placing singly in 2-inch pots, to be finally transferred into 5-inch pots when the small ones are full of roots. The plants are better outside than in cold frames after the seed has germinated until they are housed in autumn.

**Hydrangeas.**—The prevailing idea that the flower buds should be formed in the shoots of these before they are rooted in small pots for flowering another year is a great mistake. Cuttings rooted after the flower buds are set never produce such fine heads of bloom as those rooted earlier in the season before flower buds are visible. Good sturdy cuttings should be rooted now from plants growing outside fully exposed to the sun. The cuttings should be as short as possible, with a pair of large leaves left at the base. Fill 2 or 3-inch pots firmly with sandy loam and one-seventh of decayed manure. Place a little sand in the centre for the base of the cuttings to rest upon. Give a good watering, and stand the pots in handlights, shaded from the sun, in the Cucumber or Melon house, where they will root quickly. Directly they are rooted gradually expose them, and then remove to a cold frame and harden them. They should then be grown cool and fully exposed to the sun. The small pots soon become crowded with roots, and the growth is much more certain to be brought to a standstill, thoroughly ripened, and the formation of flower buds will take place sooner than when growing plants outside with unlimited root room. This is a certain method of preparing plants for producing large heads in 5 and 6-inch pots next season than attempting to strike them after buds are formed. They

root quicker and casier, and do not produce deformed heads, as is often the case when propagated later in the year.

**THE FLOWER GARDEN AND PLEASURE GROUND.**

**Budding Roses.**—It was useless to attempt budding while the extremely hot and dry weather lasted, but the welcome change ought to have been taken advantage of, as the buds unite with the wood much more surely during showery or dull weather. In many districts insufficient rain has fallen to well soak the ground about the stocks, and in this case it is advisable to water them freely one or two days prior to budding. This causes the sap to rise, and renders it a much easier matter to open the bark. If there is no moisture under the bark it not only opens badly, but there is nothing to support the newly inserted bud. A similar difficulty is experienced with the buds, as unless these "run" or part from the wood freely it is almost impossible to avoid damaging them, and it is useless to insert bruised bark. Water the plants, and the buds will soon be much more easily taken. The Manetti stock may be lightly trimmed, and be budded on the main stem about 2 inches below the surface of the ground. The soil necessarily drawn away from the stems must not be returned till such times as the buds have developed into strong shoots. The reserved shoots on the Briar stocks may also be freely shortened back, or say to within 12 inches of the stem, and the buds be inserted as near the stem as possible, where they more readily become united strongly with the stem. Either matting or worsted may be used for binding the bark over the buds, and which ought not to have been allowed to get dry before they were inserted. In hot weather it is advisable to temporarily shade the buds either with Cabbage or portions of Rhubarb leaves.

**Roses from Cuttings.**—We prefer to have as many as possible of our Roses frost-resisting, and find that we must rely principally upon dwarf bushes on their own roots. Considerable numbers are struck Gooseberry fashion every winter, and we are fairly successful with July and August cuttings. The latter are rather the longest in attaining a useful size, but are the best for potting. Any medium sized healthy growth that has perfected one or more blooms is suitable. They are best taken off with a heel and shortened to about 4 inches in length. They must be furnished with healthy leaves, the buds being dormant, and they ought to be inserted directly they are taken, as if once allowed to get dry or to flag at all failure is certain. They may be struck either in handlights or bottomless boxes covered with glass, and these should be disposed at the foot of a north wall. About 3 inches of very gritty soil, plenty of road drift being very suitable, is needed, and the cuttings should be dibbled in to half their depth and firmly, and well clear of each other. Water them in, keep them closely covered with glass, and if necessary shade before the sun reaches them. They ought to be well rooted in less than six weeks, and may then have plenty of air given them.

**Carnations and Picotees.**—Seedlings are much the most floriferous, but unfortunately they so exhaust themselves as to be quite useless for a second season. A fresh stock must therefore be raised every season, and if our advice has been taken the seedlings raised this year ought now to be fit for the borders. Being pricked off thinly in boxes they will transplant readily with a good ball of soil about the roots. A fairly rich well-worked soil suits them, and they may well be disposed 15 inches apart each way. In cold damp positions, or where the soil is naturally of a retentive character, it is advisable to plant on raised beds. If dry, hot weather follow planting, an occasional watering should be given, and all going on well they should cover the ground with flower stems by this time next year. Named sorts, or any that are extra good among the seedlings, may be increased by cuttings taken off at the present time. The small side shoots or pipings are best, and these may be slipped off and put in without further trouble being taken with them. They strike the most readily when dibbled in boxes of sandy or gritty soil in a close shaded frame over a nearly spent hotbed.

**THE BEE-KEEPER.**

**INFORMATION FOR BEGINNERS.**

In a good honey season such as the present it is remarkable how accurate the information tendered by "A Renfrewshire Bee-keeper" was in all that applies to profitable bee husbandry, while the Stewarton hive he so ably advocated is still the best hive where large supers are not objectionable. Where bees are kept for the owner's use only no hives can excel it, either in quantity or quality, while the slides so much objected to by some are the very means by which the bee-keeper can control the purity of supers. One writer told us they had "brains" to pass over the Stewarton; the same writer with the same brains now adopts the system as the best. Others I have no doubt will soon follow, and whether octagon or square are Stewarton hives, and should not be known by any other name.

**SWARMING VERSUS NON-SWARMING.**

The question of swarming or non-swarming has often been discussed. Swarms always work the better of the two, but the large yield of honey must be looked for in the non-swarming hive, if the term may be allowed, because non-swarming in the proper sense can scarcely be allowed. We can retard or delay swarming for a time, and often for a season, but if it was long enough no contrivance or plan on our part will prevent bees swarming when the queen during fine weather becomes exhausted, nor even before that if the combs are irregular, having an excess of drone cells. Swarming takes place often with hives not more than two-thirds full of comb. With everything right and in a normal state, by giving room in advance of their wants and plenty of it, will often have the desired effect for the season, but no queen should be kept for the next year that has done good service the present one. Endeavour to have all the combs for the stock or body of the hive made this season by bees having a young fertile queen and drone comb will be scant. Where that cannot be done give full sheets of foundation in the subsequent year.

**COMB FOUNDATION.**

This plays so important a part in modern bee-keeping that a few words about it may be useful, as I have made it extensively for upwards of a quarter of a century. There are many kinds of machines and ways of fixing it. In order to keep the top bar strong there is no plan yet surpasses the groove. I have had experience with five different machines and six sorts of foundation. Root's natural based cell with high side walls and thin midrib pleases the bees best both in supers and the body of the hive, while the rapidity with which the bees take to it and draw it out puts the bee-keeper in the best of humour. A few pounds spent on one of Root's foundation machines by any bee-keeper with but half a dozen hives will be money well spent, while by so doing a double advantage is gained by the bee-keeper getting foundation made from wax made by his own bees, which requires no wire nor other contrivance beyond fixing properly in the top bar with melted wax. Foundation made from sound native wax does not sag like those made from foreign wax.

**HIVES.**

The best hive for producing marketable or small samples is the square tiering hive already described, easily made by any amateur at an outlay of about 2s. 6d. only when new timber is used, and at about 1s. when old boxes are used.

**SECTIONS.**

These are not favourites of mine nor with the bees when the ordinary sort are used. The bees dislike the bottom rail. Some of the members of the B. B. K. A. advocated the use of frames minus the bottom rail, but why they denounced a rail in the frame and advocated sections having a broad bottom rail I do not know. I prefer sections wrought either in iron frames or in crates, which allow the bees to any number of sections without bottom rails and in one compartment. The latter is the only kind I use, and like most of my bee gear is easily made. The sections are in three pieces, top and ends, 1 3/4 inch broad and fully 3/8 thick. They may be either nailed or dovetailed. The crates are of the same size as hives, and divided into spaces, the size of the sections wanted. The sides of the crate have little trenches cut to receive the number of moveable bearers 3/8 thick, reaching about half way down, so as to allow the bees full scope. These thin pieces are rabbeted like the front and back of the crate to allow the sections to rest in flush with the upper

edge. The sections are kept apart the proper distance from each other by tacks driven in the end pieces, while little loose slips of wood close the openings on the top. The bees take to these sections readily, and as they hang by the top bar travel with safety, and if the packing case is glazed on the bottom have a prettier appearance than sections of the ordinary type, while they are easier manipulated on the hive. Although this season has been more favourable to lifting the first and nearly filled super, and putting the empty one beneath, in nine cases out of ten it will prove a failure. The little supers holding from 3 lbs. to 8 lbs. are more easily managed than others, and by judicious lifting partly filled ones on the top of others and placing empty ones in the place of the partly filled ones the bees are kept better at work than when crowded. Crowded hives are a great mistake. Some time since the Germans announced that a medium swarm wrought better than an extra strong one, and many of the English bee-keepers supported that statement, but it is untenable. Doubtless if 100,000 bees are crowded into a space suitable for half that number the results will be very unsatisfactory; but give them the necessary space and grand results will follow. Much error in teaching bee husbandry has arisen through people not grasping the question of profitable bee-keeping and using hives not half the size they should be.

#### LARGE SWARMS.

Not only are these the most profitable, but they work more in proportion to their numbers than weak ones. I noticed in my last article the two swarms weighing 18 lbs. Now, according to the theory that large hives did not work well, this one would not have done well, and being the first cross Syrian would have done less, but this is not the case. In fourteen days from the time it swarmed it rose in weight more than 100 lbs., and at the end of that term it gave 50 lbs. of sealed supers. So much for foreign bees and large swarms, but remember they must not be crowded into little space, nor on to a few sheets of foundation as is commonly advised.

#### WINTERING BEES.

Naturalists and bee-keepers have long studied this. I have never had much difficulty in wintering my bees successfully, but the narrower the hive the better both for that purpose and supering. If fine seasons like the present one are likely to be experienced in the future the bee-keeper should have an extra breeding box, and it can be turned to good account for that purpose. By taking the frames of three body boxes and placing them into the four boxes with the honey at the top it will never be affected by frost, and the bees will remain healthy and never suffer from want while honey lasts during the most severe winter weather. Dividing boards the whole depth may be used. That space outside the combs with the additional space between the hive and outside case will thoroughly prevent frost injuring either honey or pollen, and all damp will pass downwards through the ventilating floor. When the hive in this state becomes crowded in May the frames may be arranged properly.

The first half of July has not been so favourable for honey gathering as June was, and the great number of queens flying about has given much trouble by regicidal attacks. The late Mr. T. W. Woodbury was puzzled at these seemingly unnatural occurrences. They are all caused either by stronger bees or queens entering hives, and works much mischief, rendering the hives they take possession of very often worthless. One interesting case I had this season is worth recording as substantiating the

opinion I gave to Mr. Woodbury on the subject. A hive I had rendered queenless, and started raising pure queens, suddenly ceased raising royal cells. I observed a swarm attempting to enter, but only a few bees did so, though evidently a queen had, for the day after I gave it a royal cell that was detached from all combs, and which I found lying loose on the floor of a hive I was utilising queen cells from, which hatched immediately and was well received. Next morning I was surprised to see a queen being turned out, which I examined and dissected, and found her fertilised just as Woodbury found his, which puzzled him to know the cause. This queen had been fertilised the day previous, and the young queen was victor. Other singular facts I shall have to mention again, but it will be acting wisely if all hives are examined at the end of this month, so as to make certain a young fertile queen is at the head of every stock, or otherwise disappointment may follow.—A LANARKSHIRE BEE-KEEPER.



\* \* All correspondence should be directed either to "THE EDITOR" or to "THE PUBLISHER." Letters addressed to Dr. Hogg or members of the staff often remain unopened unavoidably. We request that no one will write privately to any of our correspondents, as doing so subjects them to unjustifiable trouble and expense. Correspondents should not mix up on the same sheet questions relating to Gardening and those on Bee subjects, and should never send more than two or three questions at once. All articles intended for insertion should be written on one side of the paper only. We cannot reply to questions through the post, and we do not undertake to return rejected communications.

**LATE INQUIRIES.**—It is necessary to again remind correspondents that letters arriving on WEDNESDAY MORNING cannot be answered in the "next issue," which is then far advanced for press.

**Strawberries at the Chertsey District Show (Visitor).**—You are quite right, some very good dishes of fruit were staged, but it is quite impossible to give the details of all classes in reporting shows at a time when the pressure is so great on our space. We think the first prize for Strawberries at the show in question was won by Mr. D. Hopkins, gardener to J. Wodderspoon, Esq., The Chestnuts, Walton-on-Thames, with a very fine dish of President; Mr. Waite following with James Veitch; and Mr. Sharpe of Knowle Hill, Virginia Water, exhibited splendid fruits of British Queen, not for competition. Mr. Sharpe's Strawberry garden has been described in the Journal, and must be regarded as one of the most remarkable in the kingdom, the plants apparently growing in a sand bed, and without any manure. We are obliged by your letter.

**Peach Trees Unsatisfactory (W. R.).**—The trees, from which you have sent shoots, require lifting. The wood of last year was not ripened, and this year's growth is much too succulent. More fibrous roots nearer the surface in firm calcareous loam are requisite for inducing firm fruitful wood. As soon as the leaves show signs of changing take up the trees carefully, shading them in the meantime, and not letting the roots get dry replanting quickly in a firm border 18 inches deep, covering the roots 4 inches, and mulching to prevent the soil drying. To twelve barrowfuls of good turfy loam add two of lime rubbish and one of wood ashes, making the soil firm. Syringe and shade the trees to keep the leaves fresh as long as possible, and fresh roots will form at once. Any long straight fibreless roots may be shortened. You may lift the trees sooner if you can keep the foliage fresh for inducing fresh root-action.

**Forget-me-nots (E. Legget).**—It is not too soon, but, on the contrary, rather too late for sowing seeds of Forget-me-nots for raising fine plants for flowering next year. We sow early in June and have sturdy plants 3 or 4 inches in diameter in the autumn. By sowing at once thinly in light soil kept continually moist the plants raised will flower next year, but must be planted closely together in the beds for producing a good effect. Strong slips of *Myosotis dissitiflora* inserted now, or as soon as they can be obtained, in moist rich soil and a shaded position make fine plants for flowering in the spring.

**Asparagus (G. D.).**—You cannot expect fine Asparagus if you allow the beds to be impoverished by weeds. There is no greater mistake than to suppose that negligence in cleaning the beds in summer can be compensated for by salting and manuring the beds in the winter. Salting in winter does little good, and may do harm in strong wet ground. We salt our beds in



spring and summer, just giving sufficient to prevent the growth of weeds, or to destroy any that may spring up the moment they are seen. Hand-weed your beds at once, then give them a good salting, 3 or 4 ozs. to each square yard not being too much, and a thorough soaking of liquid manure once a week will do your Asparagus more good than anything, provided weeds are not permitted to appropriate the virtues of the manure. We know of nothing more expensive in culture than manuring land liberally, then allowing weeds to grow luxuriantly. It is by such practice that much land has been practically ruined, and according to your letter you appear to be acting on the lines we are bound to denounce.

**Muscad Grapes (Subscriber).**—The Grapes sent, though not exactly "shanked," are very much in the condition indicated by that term. Instead of the footstalks of the berries shrinking the shrinkage occurs close to the fruit, and in nearly every case the footstalks are contracted, two showing distinct signs of gangrene. It is certain the crop is not receiving adequate support for perfecting the fruit, and a remark in your letter suggests that the border is faulty. Soil so strong that "a handful when pressed sticks like a ball" is not suitable for Muscads. Though the Vine may appear healthy in growth it is really not so, and the size of the leaves indicates an attempt to elaborate the crude sap and assimilate the nutrient matter derivable therefrom, or, in other words, as this cannot be accomplished by a reasonable expanse of foliage, a greater surface is produced in an effort to supply the deficiency, and therefore what appears an expression of health is evidence of weakness. The border may also be deficient in lime and potash, but whether that is the case or not the soil is much too close and heavy for Muscads. You must either remove the Vine and occupy its space with a rod from one of the others, or make the soil very much more porous by a liberal addition of lime rubbish, wood ashes or charcoal, and sand. The Vine should be taken up and replanted on a station of fresh soil, and the earlier that is done in the autumn the better. You have done right in guarding against giving an excess of water to soil of such a tenacious character. You had better point with great care an abundance of lime rubbish and gritty matter into the border generally, giving a top-dressing of the same, then by keeping this moist with a mulching of manure an abundance of surface roots will be induced and your Vines be kept in a good bearing state. We should do this now, and we think if something of the kind is not done there is a danger of the other Vines failing before very long.

**Raising Calceolarias (E. H.).**—Herbaceous Calceolaria seed may be sown now onwards till September, according as large or medium-sized plants are desired. The chief difficulty when sowing early in hot weather is to find a place cool and damp enough. Select a piece of ground in a shady corner, and there place a handlight. Strew the ground on which the handlight is to rest, and a space round it, with salt. On this place a couple of inches of rough coal ashes, and when the glass is put down place 2 or 3 more inches of the ashes inside. These are precautions against worms and slugs. Then take one or several 6-inch pots; fill them half full with drainage, then an inch of somewhat rough soil, filling up to within half an inch of the rim with fine light sandy loam, containing a little fine-sifted leaf mould. Press the surface, afterwards water the pots well, and allow them to drain for a day; then place a very little fine tolerably dry soil on the surface, press gently down to make smooth, and sow the seeds; then scatter over them the smallest quantity of fine sand. Press level again, place a square of glass over the pot, and set it underneath the handlight. If this is kept close, and the ashes inside moist, water will seldom be needed until the seedlings appear. When fairly up, lift the top of the handlight a little; as they grow a little larger edge up the square of glass over the pot, first at night, and then during the day. When a little larger, move the square of glass altogether, and give more air by the top of the handlight. By this time the tiny plants will have a few leaves, though it would be difficult, as yet, to handle them singly. To prevent their damping at the surface lift patches of several plants together, and prick out these patches an inch or so apart, in pots prepared as if for cuttings, or in shallow pans. If before this, notwithstanding the dampness of the ashes, the surface of the soil should be dry, soak it well, not by a rose over the plants, but by flooding the soil by pouring the water on a piece of tile close to the edge of the pot. Many young seedlings, if small, are destroyed by watering overhead; they rot off just at the surface of the soil. When thus pricked out, and thus watered, place under handlights again, and keep close for a few days. In two or three weeks it will be necessary to prick out the plants separately, leaving about 1 inch or so between each two. As the autumn advances, the strongest, to bloom in April and May, may have each a 4-inch pot, and be shifted to a larger one before the end of October; by the smaller supply may be pricked out into shallow pans a couple of inches apart, or four may be placed round the sides of a 5-inch pot. If there are more than are wanted, rather prefer the smaller and weaker-growing plants. They will soon acquire strength. Moisture, if not stagnant, will do little injury to them in winter. They may be grown with the protection of a cold frame in winter, paying great attention to air, and just securing them from frost. They are easily kept from frost in a greenhouse heated by a fire or hot-water pipes; but a close, warm, dry atmosphere is their bane. They will do well in a temperature ranging from 35° to 45°, with air and moisture in proportion. In greenhouses they will be much benefited if set or partly plunged in damp moss. They will grow rapidly even in winter, at 45° to 55°, standing in damp ashes or moss, and having plenty of air. Whenever the pots are full of roots the plants will be inclined to throw up their flower-stems, and therefore they must be shifted to prevent the roots matting, when large specimens are required.

**Names of Plants.**—We only undertake to name species of plants, not varieties that have originated from seed and termed florists' flowers. Flowering specimens are necessary of flowering plants, and Fern fronds should bear spores. Specimens should arrive in a fresh state in firm boxes. Slightly damp moss or soft green leaves form the best packing, dry cotton wool the worst. Not more than six specimens can be named at once. (J. D.).—1, *Whitlavia grandiflora*; 2, *Lycium europæum*; 3, *Epilobium angustifolium*; 4, Unrecognisable.

**Large Bees (W. B. G.).**—The bees to which you refer are drones belonging to the hive; you cannot do better than leave them to their destiny, the workers will dispose of them in due time.

COVENT GARDEN MARKET.—JULY 20TH.

HEAVY supplies to hand, with trade brisk at lower prices.

FRUIT.

	s. d.	s. d.		s. d.	s. d.
Apples, ½ sieve .. ..	0	0	to	0	0
Nova Scotia and					
Canada barrel	0	0	0	0	0
Cherries, ½ sieve .. ..	3	0	6	0	
Cobs, 100 lbs. .. ..	0	0	0	0	0
Figs, dozen .. ..	3	0	4	0	
Grapes, per lb. .. ..	1	6	2	6	
Lemons, case .. ..	10	0	15	0	
Melon, each .. ..	2	0	3	0	
Oranges, per 100 .. ..	6	0	to	12	0
Peaches, dozen .. ..	4	0	10	0	
Pears, dozen .. ..	0	0	0	0	0
Pine Apples, English,					
per lb. .. ..	1	6	0	0	0
Plums, ½ sieve .. ..	0	0	0	0	0
St. Michael Pine, each	3	0	5	0	
Strawberries, per lb. ..	0	3	0	10	

VEGETABLES.

	s. d.	s. d.		s. d.	s. d.
Artichokes, dozen .. ..	1	0	to	2	0
Asparagus, bundle .. ..	0	0	0	0	0
Beans, Kidney, per lb. ..	1	3	0	0	
Beet, Red, dozen .. ..	1	0	2	0	
Broccoli, bundle .. ..	0	0	0	0	0
Brussels Sprouts, ½ sieve	0	0	0	0	0
Cabbage, dozen .. ..	1	6	0	0	
Capsicum, per 100 .. ..	1	6	2	0	
Carrots, bunch .. ..	0	4	0	0	0
Cauliflowers, dozen .. ..	3	0	4	0	
Celery, bundle .. ..	1	6	2	0	
Coleworts, doz. bunches	2	0	4	0	
Cucumbers, each .. ..	0	4	0	6	
Endive, dozen .. ..	1	0	2	0	
Herbs, bunch .. ..	0	2	0	0	0
Leeks, bunch .. ..	0	3	0	4	
Lettuce, dozen .. ..	0	9	to	0	0
Musbrooms, punnet .. ..	0	6	1	0	
Mustard and Cress, punt.	0	2	0	6	
Onions, bunch .. ..	0	3	0	6	
Parsley, dozen bunches	2	0	3	0	
Parsnips, dozen .. ..	1	0	0	0	0
Potatoes, per cwt. .. ..	4	0	5	0	
Kidney, per cwt. ..	4	0	0	0	
Rhubarb, bundle .. ..	0	2	0	0	
Salsafy, bundle .. ..	1	0	1	6	
Scorzoneria, bundle .. ..	1	6	0	0	
Seakale, basket .. ..	0	0	0	0	0
Shallots, per lb. .. ..	0	3	0	0	
Spinach, busbel .. ..	0	8	0	4	0
Tomatoes, per lb. .. ..	0	4	0	6	
Turnips, bunch .. ..	0	4	0	6	

PLANTS IN POTS.

	s. d.	s. d.		s. d.	s. d.
Aralia Sieboldi, dozen ..	6	0	to	12	0
Arbor vitæ (golden) dozen	6	0	9	0	
(common), dozen ..	0	0	0	0	0
Azalea, dozen .. ..	0	0	0	0	0
Begonias, dozen .. ..	4	0	9	0	
Calceolaria, dozen .. ..	3	6	8	0	
Cineraria, dozen .. ..	0	0	0	0	0
Creeping Jenny, dozen ..	3	0	4	0	
Dracæna terminalis, doz.	30	0	60	0	
viridis, dozen .. ..	12	0	24	0	
Erica, various, dozen ..	12	0	24	0	
Euonymus, in var., dozen	6	0	18	0	
Evergreens, in var., dozen	6	0	24	0	
Ferns, in variety, dozen	4	0	18	0	
Ficus elastica, each ..	1	6	7	0	
Foliage Plants, var., each	2	0	10	0	
Fuchsia, dozen .. ..	3	0	to	9	0
Geranium (Ivy), dozen ..	4	0	6	0	
Tricolor, dozen ..	3	0	6	0	
Hydrangea, dozen .. ..	9	0	12	0	
Lilies Valley, dozen ..	0	0	0	0	0
Lilium lancifolium, doz.	12	0	18	0	
longiflorum, doz. 18	0	30	0		
Lobelia, dozen .. ..	3	0	5	0	
Marguerite Daisy, dozen	6	0	12	0	
Mignonette, dozen .. ..	3	0	6	0	
Musk, dozen .. ..	2	0	4	0	
Myrtles, dozen .. ..	6	0	12	0	
Palms, in var., each ..	2	6	21	0	
Pelargoniums, dozen ..	6	0	15	0	
scarlet, doz. .. ..	3	0	9	0	
Spiræa, dozen .. ..	6	0	12	0	

CUT FLOWERS.

	s. d.	s. d.		s. d.	s. d.
Ahutilons, 12 bunches ..	2	0	to	4	0
Anemones, 12 bunches ..	0	0	0	0	0
Arm Lilies, 12 blooms ..	3	0	6	0	
Azalea, 12 sprays .. ..	0	0	0	0	0
Bluebells, 12 bunches ..	0	0	0	0	0
Bonvardias, bunch .. ..	0	6	1	0	
Camellias, blooms .. ..	0	0	0	0	0
Carnations, 12 blooms ..	1	0	2	0	
12 bunches .. ..	4	0	6	0	
Cornflower, 12 bunches ..	1	6	3	0	
Daisies, 12 bunches .. ..	2	0	4	0	
Encharis, dozen .. ..	4	0	6	0	
Gardenias, 12 blooms ..	1	6	3	0	
Hyacinths, Roman, 12					
sprays .. ..	0	0	0	0	0
Iris, 12 bunches .. ..	2	0	9	0	
Lapageria, white, 12					
blooms .. ..	0	0	0	0	0
Lilium longiflorum, 12					
blooms .. ..	8	0	6	0	
Lilac (white), French,					
bunch .. ..	0	0	0	0	0
Lilies, White, 12 bunches	12	0	24	0	
Orange, 12 bunches	9	0	12	0	
Lily of Valley, 12 sprays	0	0	0	0	0
12 bunches .. ..	0	0	0	0	0
Marguerites, 12 bunches	2	0	to	6	0
Mignonette, 12 bunches	2	0	4	0	
Myosotis, 12 bunches ..	2	0	3	0	
Narciss, 12 bunches ..	0	0	0	0	0
White, English, hch.	0	0	0	0	0
Pansies, 12 bunches ..	2	0	4	0	
Peas, Sweet, 12 bunches ..	3	0	6	0	
Pelargoniums, 12 trusses	0	9	1	0	
scarlet, 12 trusses	0	4	0	6	
Pinks, White, 12 bunches	1	0	4	0	
various, 12 bunch	2	0	4	0	
Paeony, 12 bunches ..	0	0	0	0	0
Poinsettia, 12 blooms ..	0	0	0	0	0
Primula (single), bunch ..	0	0	0	0	0
(double), bunch ..	0	9	1	0	
Polyanthus, 12 bunches ..	0	0	0	0	0
Ranunculus, 12 bunches	0	0	0	0	0
Roses, 12 bunches .. ..	2	0	6	0	
(indoor), dozen ..	0	9	1	0	
Tea, dozen .. ..	1	6	3	0	
red dozen .. ..	0	0	0	0	0
de Moiss, 12 bunches	0	0	0	0	0
Stephanotis, 12 sprays ..	1	6	3	0	
Tropeolum, 12 bunches ..	1	0	2	0	
Tuberose, 12 blooms ..	0	6	1	0	
Tulips, dozen blooms ..	0	0	0	0	0



THE DROUGHT.

THAT many a light land farmer will be ruined by the drought we have been told over and over again. Certainly we have ample reason to think it must be so, for in our travels we have been over much light thin land, and a sadder sight we never saw. Much, or rather most, of the spring corn was so parched by drought that growth ceased in many a field just as the ears were visible upon the stunted stems, and the crop is a total failure. In one case we heard of a farmer who had so lost 200 acres of corn. Well might he exclaim, "This is the climax of our

misfortunes. It was bad enough to sell good corn for the low prices of last year; this year we shall have none to sell." Expressions of sympathy come readily enough to the lips when we meet with such a case—and they are common enough in certain districts this summer—but practical help is what is wanted, and that, alas! is impossible. A black year indeed will the Jubilee year be for many a light land farmer; and what makes it all the harder for him is the splendid appearance of the crops upon good mixed soil farms. We have such a farm in hand which at the present time is in a more satisfactory condition than we have ever had it before. Not only is the Wheat a fine full crop in every field, but other crops are equally good; Barley, Oats, Winter Beans, and Peas all give fair promise of an abundant yield. Peas especially are remarkably vigorous, the haulm being long, stout, and well podded. There is a capital piece of White Clover for seed on this farm, both the hay and stover are a full crop well saved, Mangolds are a full strong plant, and Swedes have grown out of all risk of harm from insects.

Repeatedly have we advised our readers to meet the agricultural depression with a full hand, with crops so abundant that a profit should still be possible. Acting upon this conviction we have striven year by year by drainage, by keeping down weeds, by sheep folding, by a judicious application of chemical manures, and by sowing pure seed of the best sorts, so to improve both the quantity and quality of our farm crops that we might make them answer while we have them in hand, and be let to good tenants in such good order that they too might still find farming both a pleasant and profitable calling. We may take it for granted that high profits arising from old prices in the good times will never again become possible, and we must therefore be content with what is often termed a living profit.

The farm to which we have called attention for the excellence of the crops upon it this year is only one of several which we have in hand, and we are glad to say that the others all show unmistakeable signs of improvement. One farm, however, cannot answer so well as the others this year. This is a large heavy land farm upon which we have expended considerable sums of money for improvements; there will, however, be from forty to fifty acres of inferior corn there this year owing in a great measure to a want of drains. The wet land may now be compared to a huge honeycomb, for it has a network of cracks all over it, which cause the crops to become parched and stunted. We greatly regret this, but with several hundred acres of land to drain it is just a question of having enough means to do all or a part only of the land. So far as we have gone the draining has been well done, and its beneficial effect upon soil and crops may now be seen clearly, for there no exception can be taken to any of the crops. Wheat and winter Oats especially are quite equal to any we have elsewhere. Winter Beans, too, and Peas are a good crop. The lesson taught by the drought here is the great importance of drainage whether the season of growth proves wet or dry. In the present summer when evaporation must be excessive the sour crude wet soil contracts so much that it is intersected in every direction by deep wide cracks, which give free admission to the hot dry air, parching the roots of spring corn and spoiling the crop. Well drained land, on the contrary, becomes so mellow and friable by the free circulation of air in it that it loses much of its original tendency to extreme cohesion, its particles do not unite like those of the undrained soil, and therefore there is little if any cracking

upon the surface. Strongly do we advise landlords to aid the tenant so far as they can to underdrain every acre of wet land. Help in such a matter is really better for the interests of both than heavy reductions of rent.

#### WORK ON THE HOME FARM.

A full crop of grass upon most pastures, a bright sky, and an exceptionally hot temperature day after day, good and willing workmen well handled, sound useful implements, plentiful relays of quick stepping Suffolk horses enabled us to bring our haymaking practically to an end a week ago. By working late for once on Saturday night we managed to clear up all the hay except a few acres which was so forward as to enable us to put the whole of it in cocks so to remain over Sunday, and then we felt safe, for a falling barometer and cloudy sky warned us to do all that was possible to get the hay together in as close quarters as we could. To do this well some half-dozen of the regular workmen were taken off from hoeing among roots to make the haycocks, and glad were we as the evening fell that we had done so, for a dozen of the extra men struck work at 7 P.M. A few minutes' thought enabled us to decide to pay them off and tell them they would not be wanted again. This done they hastened off to swallow in drink the few extra shillings paid them for overtime, while the other men cheerfully loaded up the remainder of the hay that was ready for the stack, and we took care to reward them for doing so.

We cannot conclude our "work" note this week without reference to the excellence of the Hornsby grass mower. We have had four of them at work, but one on the home farm cut 170 acres of grass without a hitch of any kind, and much of the pasture was in a rough state, unlevel, and with numerous molehills thrown up among the grass after it had become tall enough to conceal them. It is true that we had a good driver, but to go on for seventeen working days at the rate of ten acres a day is a piece of downright good work that is worthy of record. We had four sets of knives in use for this mower, and a handy man was employed the whole of the time in sharpening and putting on fresh knives as any became broken or worn. We must own that the mower was examined and put in thorough order before the haymaking began, yet even with such precaution we have known inferior implements break down repeatedly.

#### THE HESSIAN FLY.

IN my capacity as Chairman of the Seeds and Plants Diseases Committee of the Royal Agricultural Society, I have just received official information from Miss Ormerod, the consulting entomologist, of the discovery of the larvæ and puparia—pupa-cases—of the Hessian fly upon growing Barley plants in Perthshire and Cambridgeshire. This afternoon I heard from Mr. Palmer, of Revell's Hall, Hertford, that puparia can be found to a great extent all over the Barley and Wheat fields of his farm, upon which, it may be remembered, the attack was first noticed last year. It is much to be feared that the presence of this destructive insect will be found to be very general this season; and as it will be most useful and interesting to get some definite ideas of its range, I would, if you allow me, ask farmers to carefully examine their Wheat and Barley crops, and to report to Miss Ormerod, or to myself, if they find larvæ or puparia of the Hessian fly upon them. In the present circumstances no remedies can be suggested, but I hope that we may be able to recommend methods of prevention, and general measures of precaution, in due season.—CHARLES WHITEHEAD, *Barming House, Maidstone.*

#### METEOROLOGICAL OBSERVATIONS.

CAMDEN SQUARE, LONDON.

Lat. 51° 33' 40" N.; Long. 0° 8' 0" W.; Altitude, 111 feet.

DATE.	9 A.M.					IN THE DAY.				Rain	
	Barometer at 33° and Sea Level.	Hygrometer.		Direction of Wind.	Temp. of soil at 1 foot.	Shade Temperature.		Radiation Temperature.			
		Dry.	Wet.			Max.	Min.	In sun.	On grass.		
1887.											
July.											
Sunday .....	10	Inches.	deg.	deg.		deg.	deg.	deg.	deg.	In.	
Monday .....	11	29.754	69.2	64.0	N.W.	68.0	77.8	57.0	127.7	57.4	0.072
Tuesday .....	12	29.906	68.2	62.9	S.	65.8	78.2	59.2	124.2	55.9	0.124
Wednesday .....	13	30.615	69.3	62.8	S.W.	65.4	78.9	60.8	128.4	56.9	—
Thursday .....	14	29.738	75.8	68.2	S.E.	66.2	82.9	60.3	126.2	56.8	—
Friday .....	15	30.011	66.7	60.1	S.	66.3	75.6	59.8	116.8	57.1	—
Saturday .....	16	30.133	65.1	58.1	S.E.	66.2	80.3	56.0	126.2	51.7	0.264
		30.194	64.8	58.0	N.W.	65.6	78.1	55.0	122.9	54.7	0.053
		29.972	63.3	62.0		65.9	78.4	58.3	123.9	55.4	0.513

#### REMARKS.

- 10th.—Cloudy early, and occasionally during the day, with a heavy shower about 5.45 P.M., otherwise fine and bright.  
 11th.—Variable, with showers.  
 12th.—Fine and pleasant.  
 13th.—Bright and hot till about 4.30 P.M., then a slight shower, followed by a cool evening.  
 14th.—Fine and pleasant, though frequently cloudy.  
 15th.—Cloudy and cool in morning, then bright for a time; cloudy again by 4 P.M.; thunder at 4.20, followed by heavy rain and two or three flashes of lightning, very vivid at 4.31 and 4.40; showery, with lightning, in evening.  
 16th.—Fine, bright, warm day, with heavy shower and lightning in evening.  
 Another warm week, the sixth in succession, and the first of them in which any material quantity of rain has fallen. In fact from June 3rd to July 9th (thirty-six days) no rain fell except the insignificant amounts of 0.052 in. on June 8th and 0.037 in. on July 4th.—G. J. SYMONS.



29	TH	
29	F	
30	S	
31	SUN	Southampton and Liverpool Shows (two days).
1	M	8TH SUNDAY AFTER TRINITY.
2	TU	BANK HOLIDAY.
3	W	

## THE EDINBURGH SHOW OF THE NATIONAL ROSE SOCIETY.

**T**HIS Exhibition deserves, I think, a little notice beyond the ample report that you have already given of it, as there were about it some features of peculiar interest. It was the first Show that the Society has ever held beyond the border, and was calculated to bring out both the successes and the failures of Rose-growing north of the Tweed; and as one who has had a fair acquaintance with Rose showing and growing in Scotland I may claim to some little knowledge on the subject.

It was the first time that the Society has in its fullest sense proved itself national, for all parts of the kingdom were represented. Ireland was represented by the Dicksons and others, Wales by Col. Hore, Scotland of course largely, while some of our best growers from the north and south of England entered the lists. Of course the Exhibition was not what it might have been had we experienced a different season, but the drought and intense heat had proved utterly fatal to many small growers and seriously interfered with the quality of the blooms. Thus it happened that there were many blanks, and that the stands generally were not of that superior quality one would have desired to show our Scotch friends. Still, I think that they were not a little astonished at the display brought before them, especially amongst the Teas, which are but little grown in Scotland, the climate being doubtless against them in many parts, although I do not see why in the south-western districts, such as Ayrshire, Wigtonshire, and Dumfriesshire, they should not be well grown. My anticipations with regard to the Scotch Roses were exactly fulfilled. I knew that if they had a chance such growers as Smith of Stranraer, Cocker of Aberdeen, and others would show Roses that would be creditable to any exhibitor, but I doubted much of the Scotch amateur element. In truth amateurs such as we have in England hardly if at all exist in Scotland. You might search the whole country through and you would not find anywhere such growers as Messrs. Whitwell, Hall, Pemberton, Grant, Budd, Wakeley, and others one might name—growers, that is, who cultivate from eight hundred to two or three thousand Roses, and who make it their special hobby. A Scotch private grower thinks that if he has a couple of hundred plants he is doing very well. Now and then one meets with a private gentleman whose gardener takes some interest in Roses and perhaps induces his employer to increase his stock, but such growers as I have named above are an unknown race in Scotland. I remember once at a Scotch show a gentleman whose

gardener was successful (as he generally is) in carrying off the prize, being so delighted as to say, turning to his *caro sposa*, "We must have some more Roses: I think, my dear, we had better give an order to Mr. — for—two dozen!" and I have no doubt he had a considerable argument with his conscience as to whether he ought to have been so extravagant; and thus it was that the Scotch Roses as a rule were "pair bodies," and that their setting up was, save in a few instances, bad as bad could be. I know truth is unpalatable at times, but there is no use in shutting their ears and refusing to accept things because they are unpalatable. This opinion has been expressed by other writers, and I must say that until some such amateurs arise we cannot look hopefully for the future of Rose growing and showing in Scotland. So long as a grower thinks that with a hundred or two of plants he is going to enter the lists successfully in large classes he will be disappointed. Then, again, how absurd it is in these days still to permit foliage to be added, and to actually not only not insist vigorously on naming, but to offer a prize (not at Edinburgh) for a stand of Roses, with this proviso "need not be named." As to difficulties of climate being a bar to the cultivation of the Rose in Scotland, I can hardly think that those who have such examples as the nurserymen I have named above there is anything in the statement. In some places it would be impossible, as it is in some places in England, but that there are districts in which both climate and soil would equal anything in England I am quite convinced. I have received a bundle of Roses at Christmas, Hybrids and Teas cut from the open from Forres, which beat anything I had in my own garden. I have written of this at some length, for the observation was frequently made to me at the Show, "How is it the Scotch growers show so indifferently?"

But if we have thus to criticise the productions of our Scotch friends, what shall we say to their reception of us as members of the National? It was the unanimous opinion of all of us, Sassenachs though we were, that never have we experienced greater courtesy or been the recipients of greater hospitality than at the northern capital. The extreme courtesy with which we were treated, and the excellence of the arrangements made for exhibitors, were beyond all praise. The falling out of so many exhibitors owing to the weather tried these qualities very much, but did not overstrain them; and all who attended the Exhibition, I am sure, left Edinburgh with pleasant memories of Scotch hospitality and kindness.

Amongst the most noticeable features of the Exhibition was the remarkable success of the Yorkshire firm—Messrs. Harkness & Son. Not only did they carry off the very handsome Jubilee Challenge Trophy valued at fifty guineas, but also the first prize of a valuable piece of plate for seventy-two blooms. They have thus secured the two trophies north and south, and have established themselves as the champion growers of the year. Without at all lessening the credit due to them for what are the results of careful cultivation, I suppose the cooler weather of the north has told greatly in their favour. This would more especially hold good with the southern Show, where they were enabled to compete successfully against the most experienced Rose-growers in England. They have a wonderful record of success this year, which I rather fancy they will keep up to the close of the season. It is a matter of congratulation to a very ardent and thoroughly popular rosarian, Mr. T. B. Hall, that he secured the challenge trophy for amateurs, for one would have, in-



dependently of any other reason, not liked it to have gone south. It is in good hands, and will nowhere ever be more highly valued than by its present possessor.

Another feature in the Edinburgh Show which will cause it to be remembered by those who were present at it was the exhibition of new Roses; notably two—Earl of Dufferin and Sir Rowland Hill, both of them, I believe, most valuable additions, and so let me give to those who were not present some idea of them. Earl of Dufferin was raised at Newtonards in the county of Down in Ireland, and is the result of careful hybridising. It is of most vigorous growth, with fine well-developed foliage. The colour is a deep shaded crimson; the form is cupped, high centre, and the perfume very strong. It had been awarded several certificates last season, and had been sent out by Messrs. Dickson, so that it could not compete for the gold medal for a Rose not yet in commerce; but a committee of all the Judges, consisting amongst others of Messrs. Hall, Whitwell, Pemberton, George Paul, Cant, House, Harkness, and the two Secretaries of the National Rose Society, awarded it a first-class certificate, and I believe that it will prove a valuable addition to our dark show Roses.

“Ah!” someone will say, “did we not always tell you that to carefully hybridise was the only way to get good Roses?” I am reminded of a story of two brothers who were brought up as witnesses in a case. They were both hale men of some fourscore years. One brother gave his testimony, and the Judge, addressing him as a fine fellow, said, “I have no doubt you have been a temperate man all your life.” “Yes,” was his reply; “I have never for forty years drank any strong drink.” “Ah! I thought so,” was the rejoinder. The second brother was a ditto of the first, and the Judge addressed him in the same way. A titter ran through the Court, for the man was well known. “Well, to tell the truth, your lordship, I very seldom goes to bed sober.” For the next Rose, and one which also secured the gold medal of the National Rose Society, was a chance seedling, and not the result of any artificial hybridising.

Sir Rowland Hill was raised by Mack & Son of Catterick Bridge, and is a most distinct variety. It bears a very great resemblance to an old Rose which was of a lovely colour, but too small ever to be of use as an exhibition flower—Souvenir de Dr. Jamain. Sir Rowland Hill is of the same shade of colour, a beautiful dark ruby claret, which does not fade into a dirty magenta colour as so many of the red Roses do. It is of good size and build, and in all respects will be a valuable addition. It is also said to be a good autumnal bloomer. Messrs. Dickson and Son, the raisers of Earl of Dufferin, also exhibited some other seedlings, amongst them one which has some elements of promise in it—Countess of Dufferin. It is of a light colour, very full, very vigorous, and good in habit. Of the new French Roses there is not much to report. The American Bride has proved itself to be a good Rose, but I apprehend that the honours of the year for new Roses will be awarded to those I have described above.

Where our next provincial Show will be held is unknown, but nowhere will there be more pleasant memories than those connected with Edinburgh.—D., *Deal*.

## THE ROYAL HORTICULTURAL SOCIETY.

### A RE-ORGANISATION SCHEME.

THE following outline of a scheme for re-organising or re-modelling the Royal Horticultural Society has been addressed in the form of a letter by Professor Michael Foster to the President, Sir Trevor Lawrence, Bart., M.P.; for consideration and publication.

The general plan is excellent, and the suggestions are valuable, though a few of the details would probably require some modification. It merits the earnest consideration of all who wish to see the Society placed on a more substantial basis.

DEAR SIR TREVOR,—The resolution adopted by the meeting of Fellows on Tuesday, July 12th, was, in reality, a decision not only as to the home, but also as to the policy of the Society. By the resolution the Fellows indirectly expressed their intention that the Society should devote itself to the advancement of horticulture, and should undertake nothing that was not distinctly calculated to advance horticulture. I may now, therefore, venture to do, what previous to that decision would have been useless, to put down on paper some suggestions as to the organisation of the Society best calculated to secure its object, the advance of horticulture. I will divide my remarks into heads.

I. THE FELLOWS OR MEMBERS OF THE SOCIETY.—These naturally fall into two categories:—1, Those who pursue horticulture as a profession, “the trade,” as it is sometimes called, and gardeners receiving salaries; and 2, Those, like yourself and myself, who garden as an amusement and relaxation, the “amateurs,” as we are called. Both these, as far as the Society is concerned, have identical interests; they will both be benefited by its prosperity, and by its being managed so as to advance horticulture. It seems to me useless and mischievous to raise the question which class is the more important to the Society. I myself think the first body is the more important, but I refuse to raise the question. It is enough that they are both, though in different ways, essential to the Society. It follows that they should both take part in the management of it.

In the few brief remarks which I made at the meeting I insisted, following Mr. Shirley Hibberd, on the necessity that the Society should be national, not local, not even metropolitan. It is necessary that the organisation should be such as to allow provincial members to have due influence.

II. THE FUNCTIONS OF THE SOCIETY.—These may be sub-divided.

A. JUDICIAL.—The forming and making known of authoritative judgments on the names proper to be applied to, and on the horticultural value of new plants (I throughout use the word “plant” as short for flowers, fruit, shrubs, &c.), and on the value of cultural specimens, of horticultural appliances, and the like. Much valuable work in this direction has been and is being done by our several Committees, but there is, I venture to think, still room for improvement, especially in two directions.

In the first place the bestowal of medals is ridiculously superabundant; being showered down as they are, they have lost all distinctive value.

In the second place some means are needed for the verification of names. No plant ought to receive the Society’s medal, prize, or certificate without the name under which the plant has been shown having been verified by competent authorities; this will cause some additional trouble in the way of making arrangements that the plant shall be submitted to competent authorities, but the award of the Society ought to be of sufficient importance to justify the trouble being taken. In the case of a new plant exhibited for the first time, and receiving an award as a new plant, still more trouble ought to be taken. I do not myself see how such awards can be safely made without some careful system of reference. A plant submitted for a certificate of being a new plant ought to be referred to competent referees, who should send in a written report, and no certificate should be given except upon such a report. These reports, with descriptions of the plants, and, if possible, drawings, and dried or otherwise prepared specimens, if preserved by the Society, would be of immense value. This of course means a more complete organisation of the Committees than we have at present, but to this I will return.

B. EXPOSITORY OR PROPAGANDIST.

(a.) Shows.—It is unnecessary to urge that shows of the nature of our fortnightly shows must continue to be a prominent feature of the Society. These are shows to show plants, to instruct the public as to what is being done in horticulture, not to furnish a gala entertainment. Hence, though arrangements of plants may be made at these shows to illustrate their aesthetic value, the great object must always be to call attention to individual plants.

I share with many the view that, at all events, during certain parts of the year, it is desirable that there should be intermediate shows in the intervening weeks; or, rather, I would go further, and say that when we possess adequate accommodation we might, I believe, without very much trouble, by proper arrangement, provide a continuous show, open always, so that any horticulturists visiting London would always find some objects of interest to see. Everyone must be aware how much we lose by plants not happening to be in bloom on the days of the fortnightly shows. It seems, moreover, not impossible to adopt a plan, by which notice should be given of the plants likely to be on view at such and such a time.

From what I hear, I am also inclined to think that the day of the week and the time of day fixed for the fortnightly shows may fitly be reconsidered.

In spite of the disaster at Liverpool, I am still of opinion that provincial shows and meetings ought to be held, if not annually, then every two, three, or four years. This seems only just to the provinces, if the provincial horticulturists are to belong to the Society. But it ought to be understood that such a provincial show or meeting is really a *visit of the Society* to the town or city where the show is held, for the

purpose of promoting horticulture there, and should be carried out accordingly.

(b.) *Meetings.*—In the old times the meetings of the Society, when plants were commented on and discussions took place before the Fellows generally, were of great interest, and might with benefit be revived, under precautions that they do not become too formal. At present the Scientific Committee within the Society, and the Horticultural Club outside the Society, supply this want; but to neither of these are the Fellows as such admitted. The evening meetings, which the late Mr. Mangles and myself got up some years ago, were undoubtedly successful, though carried out on too ambitious a scale; and I cannot but think that some such meetings, held either in the afternoon or evening, or sometimes in the afternoon and sometimes in the evening, would be attractive to the Fellows, and most useful.

But still more useful than such meetings, which must be more or less formal, would be the informal meetings of horticulturists which would take place did the Society occupy adequate premises in a central position. The rooms of the Society ought to be the "House of Call" for all interested in horticulture, or to speak more plainly, the Society ought to contain within itself a Horticultural Club. If the Lindley Library were properly housed, with suitable reading, writing, and conversation rooms; with the possibility of obtaining refreshments, and especially with the added attraction of the small continuous show spoken of above, we should, I venture to think, secure a very large support from provincial horticulturists.

C. *PUBLICATIONS.*—Although it is perfectly true that the gardening papers furnish on their own account excellent reports of what is going on in the Society, and the necessity for an independent publication by the Society is not so urgent as it was in the early days of the Society, still there seems to me to be ample reasons why the Society should issue as a Journal an authoritative account of the work of the Society. Such a journal, issued to all the Fellows, fortnightly or monthly, would not really clash with the gardening papers, and every Fellow would then be able to learn what the Society was doing.

There seems to be also a distinct want of some channel for the publication of horticultural communications which are too long for the gardening papers; for such papers as these and for such matters as the frost report, the old Transactions might be revived as a second means of publication, keeping the journal for the more simple record of the business of the Society.

D. *INVESTIGATIONS.*—In the old time the Society sent out explorers to investigate the flora of distant countries, to the great profit of science and of horticulture, and to the great profit of the Society. Perhaps it is vain to hope that anything of the kind can ever be done again; but at all events the Society might and ought to institute or support horticultural investigations at home, at Chiswick, or elsewhere, in a more systematic manner and with a greater scope than at present, valuable as is the work of the kind still carried on at Chiswick.

E. *EDUCATION.*—In the bye-laws of the Society, as they at present stand, are regulations for a Committee of Education; and indeed in old times the furtherance of horticultural education was laid down as one of the important duties of the Society. There is at the present time every reason why the Society should at once seriously take up this most important though most difficult task.

Such it seems to me are in brief the chief functions of the Society. To attempt to carry them out is to a large extent to go back to the old lines on which the Society was founded, and on which it was once so successful.

### III.—THE ORGANISATION OF THE SOCIETY.

A. *THE COUNCIL.*—There can be no doubt that the Council is not in touch, as it should be, with the horticulturists of the kingdom, in spite of its being a more active and industrious body; it is indeed the most hard-working Council with which I am acquainted. But I do not share the views of those who look for improvement in a more popular mode of election. I imagine that everyone with experience in such matters will admit that to leave the selection of new members of Council to the accidents of a general meeting of Fellows is the way least likely to result in a good Council. The real fault is that the Council is too small a body and undertakes too much work; it attempts to do everything itself, instead of relegating some of its duties to other bodies of Fellows.

An increase in the Council cannot be made without a change in the Charter, and I am myself inclined to believe that a new charter is almost essential to any real prosperity of the Society. If the Council consisted of twenty-five members, that is of twenty-one members in addition to the President, Treasurer, Hon. Secretary, and Chairman of General Committee (see below) of which twenty-one, one third (seven) were ineligible for election each year, the Council would be a very different body from what it is now, and would be much more truly representative of horticulturists even though the new members of Council were elected on the present system.

But, without having recourse to a new charter, with the number of Council remaining as at present, much might be done by the Council remitting some of its functions to other bodies of Fellows. This would necessitate a change in the organisation of—

B. *THE COMMITTEES.*—My experience of the British Association for the Advancement of Science leads me to believe that much might be effected by the institution of a GENERAL COMMITTEE, who might do much that is now done by the Council, a sort of "Lower House" in fact, to be organised somewhat as follows:—

1. The nucleus of the General Committee to be nominated in the first instance by the Council. Subsequent elections to the Committee to be made by the Committee itself, the Council perhaps reserving the right of veto, but not more.

2. Every candidate for election into Committee shall be a Fellow of the Society. We may, as heretofore, utilise the help of botanists and others who are not Fellows, and may give them in return certain privileges, but not that of belonging to the General Committee, which as will be seen, will be in reality a governing body.

3. The qualification for admission to the Committee shall be evidence not only of the desire, but also of the ability to promote horticulture; that is to say the candidate must be a person of horticultural reputation, and likely to be a useful member of the Committee.

4. Every candidate shall be duly proposed at one meeting of the Committee, with a written certificate stating his claims, and shall be voted for at some subsequent meeting. That is to say, the election shall be of a definite, formal character.

5. Anyone elected a member of the General Committee shall remain on the Committee during his life, or as long as he pleases, subject to removal for special reasons, in a manner to be specially provided.

6. The number of the Committee shall not be limited.

7. Such members of the Committee as may from time to time be elected to serve on the Council shall, while serving on Council, continue to exercise their functions as members of the Committee.

8. The Committee so constituted shall, each year, form, out of their own numbers—

- a. A Fruit Committee,
- b. A Floral Committee,
- c. A "Nomenclature" or "Name" Committee,
- d. A Scientific Committee,
- e. A Chiswick Committee,
- f. A Publication Committee;

and any other Special Committee which they may see fit; provided always,

That a certain proportion of each Committee (one in ten for instance) be members of Council for the time being; and

That the Council have the power of veto over any name selected as member of any Committee, but not of substituting any other name, the General Committee in the case of such a veto proposing a new name until the Council and Committee are agreed.

9. The General Committee and the Special Committees shall have executive powers, including that of spending such sums of money as have been granted by Council, annually or otherwise, but any expenditure beyond such grants must be previously sanctioned by Council, and in general, the conduct of the General and Special Committees shall be governed by regulations approved of by Council.

10. The Chairman of the General Committee shall be re-eligible for election, and shall be a permanent member of Council.

In other words the Council will retain its hold upon the finances, and upon the general policy and conduct of the Society, but many of the administrative details will devolve on the Committees.

Many details of course require to be filled in, as to the meetings of the General Committee, the relations of the Fruit and Floral Committees to the Nomenclature Committee, instituted to insure correct nomenclature, the duties of the Chiswick Committee, and the like, but these may be left for the present.

Thus a system of regulations would have to be drawn up for the conduct of the general and Special Committees, and had better perhaps be incorporated in the bye-laws of the Society.

At the beginning of the year the Committees would be appointed, and the Council would apportion grants of the funds of the Society to the several Committees to enable them to carry on their annual work. The General Committee would probably meet, say, quarterly, and report quarterly to the Council, who would issue the reports to the Fellows.

Within the limits of their regulations, and at an expenditure not exceeding the sum allotted to them, the Committees would have power to act independently of the Council, and there would be no necessity for the Council to revise the acts of the Committees, such as the granting of medals, &c., but all action leading to extra expenditure and all matters beyond the regulations would have to be referred to the Council.

C. *THE SECRETARY.*—Though I do not share the views of those who desire to have a paid Secretary to manage the Society, and so eventually to become the master of the Society, but think that the Fellows ought to manage their affairs themselves, I have always been of opinion that a paid Secretary is necessary, that the secretarial labours ought to be so great as to require the whole time of some one man; if the foregoing plan were adopted, and the Society flourished, it might become a question whether we did not need two paid officers, one a horticultural or internal Secretary, and the other a business or external Secretary; but this may be left for the present.

IV. *SUBSCRIPTIONS.*—There is no doubt whatever in my own mind that we ought to have £1 1s. subscribers as well as £2 2s. and £4 4s. subscribers. I see no difficulty in making most of the privileges (votes, admission, &c.) of the £2 2s. subscribers double, and those of the £4 4s. subscribers fourfold those of the £1 1s. subscribers. We might, with advantage, also revive the associates, that is to say, grant to suitable persons the privilege of fellowship (except the right of voting)

upon the payment of a very small subscription, or without any payment at all.

On the whole it does not seem to me desirable to make any distinction, as regards subscriptions, between provincial and metropolitan Fellows. We ought to make it worth the while of horticulturists in the provinces to join the Society, but leave it to each one to determine for himself or herself what subscription he or she shall pay.

If we obtained a new charter, it might be worth while to discuss the question whether it would be desirable to make a distinction between Fellows and Members, reserving the former title for those who served on the General Committee.

#### V. ACCOMMODATION.

According to the above scheme we should want :—

- 1, Offices, with Secretary's room, &c., &c.
- 2, A room large enough for the fortnightly shows, with power, if possible, to use the room between the fortnightly shows.
- 3, Committee rooms, at least three, one large enough to be used for meetings of Fellows.
- 4, Library and reading rooms, with arrangements for the housing of the records of the Society, Drawings, Herbarium, &c.
- 5, Conversation and refreshment rooms.

This accommodation, in my opinion, had *much better, in the first instance*, be of a *temporary* nature; we should then have time to find out what we really wanted.

Such, dear Sir Trevor, is a brief sketch of my notions of what we want and what we ought to aim at.—Yours truly, M. FOSTER.

*Shelford, Cambs, July 6th, 1887.*

### LILIUM HARRISI.

GIVEN certain treatment, this fine Lily is perhaps the most useful to either amateurs or growers in quantity of cut flowers in the whole genus; certainly it is the best by far of the long-flowered or trumpet section to which it belongs. Some two or three years since when this Lily first made its appearance, I, for one, opposed it as a genuine introduction, or what will be more strictly correct, I refused to recognise, in the specimens shown me, anything distinct from *L. longiflorum eximium*. But the true *L. Harrisii* is very distinct, and I have since grown it in quantity. The bulb itself is inclined to be somewhat long and conical, the scales narrower and less imbricate, and in these respects more nearly allied to that well-marked form of *L. longiflorum* known as *Wilsoni*; indeed I believe *L. Harrisii* is but a selection from this, for its length of trumpet, its height, and general aspect all agree with *Wilsoni*. But the great distinction with *Harrisii* is that two or three successional flowerings may be had from it in one year, the which cannot be said of another of this family. I flowered plants early in the present year, and the same are flowering again without potting (in fact they flower best when root-bound) or without any special culture more than supplies of weak liquid manure and soot water combined occasionally. Later plants which only recently flowered are now pushing new growths from the base to produce flowers.

As a hardy plant for the border this Lily is never likely to become popular, for many districts at least. For the south coast of France or the favoured parts of Devon it may do to a certain extent, but generally it will not succeed much in this way under the usual treatment for this section out of doors. I have beds of it side by side with typical *longiflorum* and the variety *eximium*, all of which were planted the same time and given the same treatment exactly, the soil being a fine fibrous loam and plenty of it overlying gravel. In an almost incredibly short time *L. Harrisii* appeared above ground, sooner, in fact, than I wanted it, for as the whole of these were planted in autumn, I did not expect to see them pushing through the soil till the bad weather had passed. *L. Harrisii*, however, could not content itself below, and ere frost arrived it was about 2 inches through the soil. It battled very bravely with the long-continued and severe frost of last winter, and with the protection of a few boughs I fancied it was all right; but it has done no good, and only one or two made any attempt to flower, while the remaining two, which never appeared till frost had gone, are now finely in flower and bud. If I remember rightly, your correspondent, Mr. Murphy, Clonmel, some time since sought information as to the hardiness of *L. Harrisii* for border culture, and he may, if this meets his eye, get the required information. No doubt the failure of my plants was due to premature growth, and this just on the eve of winter. But it must be remembered that permanently planted bulbs are open to similar evils, and as this Lily commences its new growth when the flowers are expanding, it is not unlikely that these, in our climate at least, would soon feel the effects of frost and cold, as the growth would be more advanced. These checks, however, do not appear to stop the

increase of the bulbs, which goes on at a brisk pace below, since a batch which I had last year in the open produced a number of small and medium-sized bulbs, most of which will develop into flowering bulbs this season. Apropos of its ever-growing capabilities, I may mention a parcel of injured bulbs (imported ones) which had made new growth in transit. These came to hand in all sorts of contorted ways, so much so that it would be impossible to plant them without breaking them, so taking its free growth into consideration, I cut them all off to within 2 inches of the apex of the bulb. They soon made a new side growth, and I expect all will flower, though somewhat later than usual.—J. H. E.

### CAULIFLOWERS.

HAVING seen your note anent the trials of Cauliflowers at Chiswick, I send you a brace of Dean's Snowball Cauliflower, which are a fair sample of what we have been cutting since 20th June. They were sown in the greenhouse on the 24th of February last. I find better results by so doing than if they were subjected to a higher temperature. Those sent are not quite so good as I have had them in previous years. Our soil being shallow, light, and very poor, they were never watered, but were well supplied with wood ashes at the roots. As I described last year in an article in your Journal, in 1885 I sowed on 24th February, and cut the first heads on 16th June; the stems were about 6 inches long, the heads appearing to lie on a bed of leaves.—JOHN SWAN, *Gardener, Kilmalcolm.*

[The Cauliflowers are very close, white, solid, and altogether good. We have seen few equal to them in the south during the present very hot and dry season.]

### PACKING FRUIT.

MANY thanks to Mr. W. Bardney for his excellent paper on the above subject. I have read it with the greatest interest, and though I have not much to add or alter, I would like to have a few lines. I have tried many ways of packing Grapes for travelling long distances, by rail and also parcels post, but the latter is a failure. I was glad to see that Mr. Bardney advises that paper be used instead of wadding. This is required in some cases perhaps at the bottom and the top, but in no case should wadding touch the Grapes. In my opinion packing mixed hampers or boxes is a mistake, yet necessary sometimes on the score of convenience or carriage charges. If put in a box or basket, the Grapes being securely tied, they should travel well. Generally, however, these large packages are sent by goods train, then it is folly to expect either Grapes or any other fruit to arrive in good condition. It is not always the fault of railway servants at either end in loading or unloading, but it is the shunting. You have only to watch this operation from time to time, and the wonder is, not that the goods reach their destination, but that they travel so well. I have looked into a composite goods truck on arrival, and see packages labelled "This side up, with care," the label side unfortunately being at the bottom instead of the top. No packer can meet this. Having, when packing for market, to pack in small quantities to oblige the salesman, I well know there is no safer mode of sending than doing on my plan, small handed baskets in which from 2 to 12 lbs. can be packed. Special Grapes are packed in flats, and these flats are slipped into hampers. Whatever plan is adopted, a good under packing is required for the Grapes to lie on. Then every bunch must be tied, to prevent moving, and a sheet of white cap or tea paper, is the best protection for the top.

My packing, after delivery, allows of each bunch being so dished that in nine cases out of ten I would defy any ordinary observer to know the difference between them and Grapes cut direct from the Vines. Again, a friend of mine, on the score of economy in boxes and carriage, stages his Grapes for exhibition from these handled baskets, setting them up on portable boards. After, however, we have done our best in packing, and they are delivered right, we are simply at the mercy of those who can make or mar the effects, not only of the packer, but the grower also. The steward, housekeeper, cook, or whoever unpacks and dishes the Grapes is, after all, either our best friend or enemy, as the case may be. I have in competition sent in both kinds of baskets, and though the handled one took first prize the third day after leaving my hands, I thought the Grapes in one quite as perfect as those in the other, and Buckland Sweetwater was packed in the flat.—STEPHEN CASTLE, *West Lynn.*

### A GARDEN PEST.

WE are nearly at our wit's end; the enemy that spoiled our bulbs is now spoiling our Chrysanthemums, fine healthy plants all at once without the slightest warning flag right down. On searching we can find the soil full of little thread-like worms from an eighth of an inch long to an inch. They are also doing the same by our Souvenir de la Malmaison Carnations. What to do with them I cannot imagine. We are trying lime water to-day; gas water of sufficient strength to kill the insects we find also kills the plants. It seems to me there is nothing they will not destroy; the list at present is Lilliums, Hyacinths, Crocus, Geraniums, Amaryllis, Chrysanthemums, and Carnations. I never felt so completely done in my life. Will you please mention



this in the Journal this week if you can? perhaps someone may suggest a remedy.—W. B. R.

[We shall be glad if any of our readers can suggest a remedy for the benefit of our correspondent and others whose plants may be similarly attacked.]

### LAXTON'S NOBLE STRAWBERRY.

THE accompanying engraving, from a photograph, has been placed at our disposal, and as will be admitted represents a truly noble fruit. Plants will be distributed during the autumn with approving testimony of competent judges. Laxton's Noble Strawberry was certificated at the Provincial Show of the Royal Horticultural Society last year, and a gardener of great experience sent us the following as his estimate of his fruit.

"It is a magnificent variety; as early as Black Prince and larger than any variety with which we are acquainted. The fruits are well formed, beautifully coloured, and highly attractive. A large dish of fruits was shown at Liverpool, as well as a trayful of clusters as cut from the plants to show the free-fruited character of the variety, and in both instances nothing could be more satisfactory. It thoroughly de-

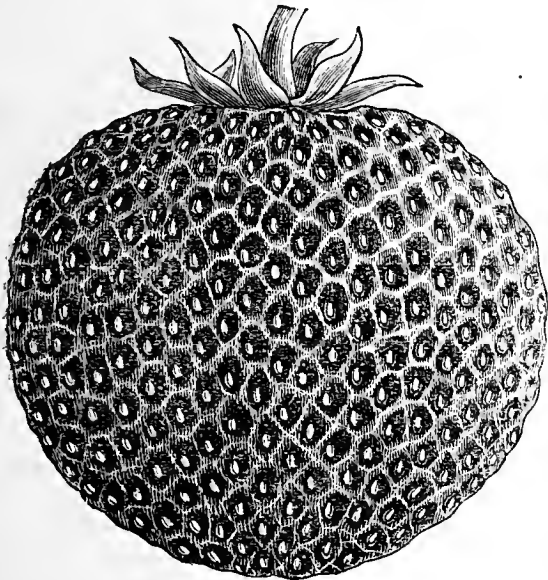

Fig. 7.—Laxton's Noble Strawberry.

served the certificate awarded, and we congratulate Mr. Laxton on its production."

### NATIONAL CARNATION AND PICOTEE SOCIETY. SOUTHERN SECTION.

THE annual gathering of Carnation and Picotee growers took place in the Conservatory at South Kensington on Tuesday last, and proved much more satisfactory than might have been expected in such a season. There was, however, abundant evidence that those who grow small collections had experienced some difficulty in making up their stands, and there was perhaps more than usual difference between the first and the following prizewinners in the respective classes. Mr. Turner was especially strong, the Slough blooms comprising some admirable specimens, and they gained many honours. There were several fresh exhibitors, and the entries were fairly numerous.

The premier Carnation was Alisemond, a scarlet flake seedling raised by Mr. Douglas, and shown by Mr. Henwood. The premier Picotee was Liddington's Favourite, a red light-edged variety shown by Mr. J. Douglas in his first prize stand of twelve blooms.

Certificates were awarded for the following:—

*Carnation Purple Emperor* (C. Turner).—A large rich purple crimson self flower, petals broad, and bloom full. A handsome showy variety.

*Carnation Will Threlfall* (C. Turner).—A bright clear yellow self variety, very handsome.

#### CARNATIONS.

In Class A for twenty-four varieties, Mr. C. Turner, Slough, won first honours with bright handsome blooms of the following varieties:—Back row—Robert Lord, H. K. Mayer, Mars, Jas. Taylor, Robert Lord, Jas. Taylor, George, and Jessica. Second row—Rob Roy, Squire Llewelyn, John Ball, Capt. Preston, John Keat, Outsider, Mrs. Bridgewater, and Sporting Lass. Front row—Sporting Lass, Wm. Skirving, Sarah Payne, Matador, Jas. Mackintosh, Sarah Payne, Jas. Mackintosh, and Rob Roy. Mr. J. Douglas, gardener to F. Whitbourne, Esq., Great Gearies, Ilford, was a close second with neat blooms. Mr. H. Catley, 16, Cloverton Buildings, Bath, was third; and Mr. F. Hooper, Widcombe Hill, Bath, was fourth. There were six competitors.

In Class B for twelve blooms Mr. J. Douglas won first honours with a beautiful stand, very bright and clean specimens. Back row—Jas. Douglas, Robert Lord, Thalia, seedling. Second row—Miss Gorton, Rob Roy, seedling, Alisemond. Front row—Three seedlings and Squire Llewelyn. Mr. J. Lakin was second; Mr. W. L. Walker, Earley, Reading, third; Mr. Huson Morris fourth, and Mr. Buxton fifth.

Mr. M. Rowan had the best six Carnations, good blooms of John S. Hedderley, G. Melville, Matador, Mrs. Gyles, Rob Roy, and Admiral Curzon. Mr. Austen, Mr. C. Phillips, Mr. H. Startup, Bromley, Kent, and Mr. G. Morris followed in that order, there being ten competitors.

*Single Specimens*.—These were not quite so numerous in some previous years, but about seventy were staged.

*Scarlet Bizarres*.—First and fourth, Mr. C. Turner with Robert Lord and George; second, Mr. Rowan with Admiral Curzon; third and fifth, Mr. Douglas with Robert Lord.

*Crimson Bizarres*.—First, second, and fifth, Mr. Turner with Sarah Payne and Wm. Skirving; third and fourth, Mr. Douglas with Miss Gorton.

*Purple Flakes*.—First, second, and third, Mr. Douglas, with James Douglas; fourth, and fifth, Mr. C. Turner, with Squire Llewelyn.

*Scarlet Flakes*.—First and third, Mr. Turner, with John Ball and Matador; second and fourth, Mr. Douglas, with Matador; fifth, Mr. Walker, with Clipper.

*Rose Flakes*.—First and second, Mr. Douglas, with Thalia; third, Mr. Rowan, with Jessica; fourth, Mr. Turner, with S. Newman; and fifth, Mr. Austin, with Mrs. May.

#### PICOTEES.

In Class E, for twenty-four Picotees, Mr. C. Turner took the lead amongst four exhibitors, showing very clear symmetrical blooms. Back row—Favourite, Jessie, Orlando, Dr. Abercrombie, Orlando, J. B. Bryant, Juliet, and Favourite. Second row—Mrs. Gorton, J. B. Bryant, Mrs. A. Chancellor, Lucy, Wm. Summers, Lucy, Princess of Wales, and Baroness Burdett Coutts. Front row—Zerlina, Mrs. Payne, Mrs. Gorton, John Smith, Zerlina, Lord Valentia, Mrs. Payne, and Lord Valentia. Mr. J. Douglas followed in the second place. Mr. F. Hooper was third, and Mr. H. Catley fourth.

In Class F, for twelve blooms, Mr. J. Douglas was awarded the chief prize for a neat and excellent collection, comprising in the back row—Brunette, Liddington Favourite, Constance Heron, and Mrs. Gorton. Second row—Seedling, Her Majesty, and two seedlings. Front row—two seedlings, Mrs. Williams, and Mrs. Sharpe. Mr. M. Rowan, 36, Manor Street, Clapham, was second. Mr. J. Lakin, Temple Cowley, Oxon, third; and Miss Buxton, 27, Manor Street, Clapham, fourth.

For six Picotees Mr. Huson Morris, The Nest, Hayes, Kent (gardener, Mr. G. Wynne), was first for fresh blooms of Clara Penson, Princess of Wales, Constance Heron, Nymph, Liddington Favourite, and Lucy. Mr. C. Austin, Brill, was second; Mr. W. Meddick, 7, Hampton Row, Bath, third; Mr. C. Phillips, Hamilton Road, Reading, fourth; and Mr. J. Rebbeck, 5, Bivas Terrace, Southampton, fifth. There were nine entries.

*Single Specimens*.—The single specimens of Picotees were numerous and good.

*Heavy-edged Red*.—First and fourth Mr. Douglas with Brunette, and second and third Mr. Turner with J. B. Bryant and Lord Valentia. Fifth Mr. Rowan with J. B. Bryant.

*Red, Light-edged*.—First and second Mr. C. Turner, with Thos. William and Mrs. Gorton. Third, Mr. Rowan, with Thomas William. Fourth, Mr. Douglas with Dr. Horner; and fifth, Mr. Headland, with a seedling.

*Purple, Heavy-edged*.—First and fourth, Mr. Douglas, with a seedling and Muriel. Second and third, Mr. Turner, with Muriel. Fifth, Mr. Rowan, with Alliance.

*Purple, Light-edged*.—First and fourth, Mr. Headland, with Pride of Leyton and a seedling. Second and third, Mr. Turner, with Baroness Burdett Coutts and Mary. Fifth, Mr. Douglas with Baroness Burdett-Coutts.

*Rose or Scarlet, Heavy-edged*.—First, Mr. Rowan, with Edith D'Ombrain. Second and fourth, Mr. C. Turner, with Mrs. Payne. Third and fifth, Mr. Douglas, with a seedling, and Mrs. Sharpe.

*Rose or Scarlet, Light-edged*.—First and second, Mr. Douglas, with Liddington's Favourite. Third and fifth, Mr. Turner, with Liddington's Favourite and Ethel. Fourth, Mr. Rowan, with Nellie.

*Yellow Grounds*.—First and second, Mr. Douglas, with Agnes Chambers. Third and fourth, Mr. C. Turner, with Prince of Orange.

In the seedling class, Mr. Douglas was awarded the first prize for a purple heavy-edged variety, very rich and clear. Mr. Headland was first with a purpled light-edged variety, named Pride of Leyton, and Mr. Douglas second with a seedling.

#### SELFS, FANCIES, AND YELLOW GROUNDS.

In Class 3, with twenty-four blooms, Mr. C. Turner, Slough, was first with grand blooms of the following—Back row—Guardian, The Governor, Purple Emperor, Florence, Rose Celestial, and Purple Emperor. Second row—Florence, Squire Llewelyn, Will Threlfall, seedling, The Governor, and Will Threlfall. Third row—Jessica, Lady Rose Molyneux, Arthur Medhurst, Rosa Bonheur, Janira, and Mrs. Champneys. Front row—Robert Lord, Thos. Page, Scarlet Gem, George, The Bride, and Scarlet Gem. Mr. J. Douglas was second with fresh clear blooms; Mr. F. Hooper third; Mr. H. Catley, Bath, fourth; and Mr. J. Serle, Bath, fifth.

Class K, for twelve self or fancy blooms, was an interesting one, no less than eleven competitors entering. Mr. Lakin was placed first with Marchioness, Duchess Teck, Ella Morris, seedlings, Pride of Penhurst, John Sloper, Sir F. Roberts, Marshal Niel, Sparkler, and Alice Ann Mary. Mr. M. Rowan, Mr. H. Morris, Mr. A. Spurling, and Mr. C. Phillips were the other prizetakers. With yellow ground Picotees Mr. J. Douglas, Mr. C. Turner, Mr. F. Hooper, and Mr. A. Spurling were the prizewinners in the order named. In the class for nine plants in pots Mr. Douglas was first and Mr. Turner second.

The Turner Memorial prize for six Carnations and six Picotees brought eight competitors, the leading position being gained by Mr. M. Rowan with the following well-represented Picotees—Edith D'Ombrain, Countess of Wilton, Favourite, Mrs. Gorton, Constance Heron, and Alliance; Carnations, Mrs. Skirving, Jessica, John Whittham, G. Melville, Master Fred, and Robert Lord. The second place was taken by Mr. Lakin, the third by Mr. Henwood, and the fourth by Mr. Phillips.

*MISCELLANEOUS*.—Messrs. J. Veitch & Sons, Chelsea, exhibited six stands of Carnations and Picotees, comprising about 240 blooms, including

all the best varieties both for borders and exhibition. Ernest Benary Erfurt, Germany, sent flowers of a yellow self Carnation named Ernest Benary, which were highly commended. Mr. J. Douglas had some glass stands and buttonholes of Carnations and Picotees, which were very highly commended.



IN consequence of the demands on our space by Rose shows and other reports the publication of the index to the half-yearly volume ending June 30th has been deferred to the present issue of the Journal.

— WE are informed that the Right Hon. Joseph Chamberlain, M.P., has consented to take the chair at the forty-fifth anniversary festival of the GARDENERS' ROYAL BENEVOLENT INSTITUTION to be held in the summer of 1888. The consent of Mr. Chamberlain was obtained through the influence of Baron Ferdinand de Rothschild and Sir Robert Peel.

— THE PRINCE CONSORT'S ASSOCIATION SHOW AT WINDSOR was held on July 19th, and in the large tent adjoining the Royal enclosure was a fine exhibit from Messrs. Sutton & Sons, the Queen's seedsmen, Reading, which included a capital collection of their superb strain of Gloxinia, six boxes in distinct colours of seedling Hollyhocks with flowers remarkably double; white, red, and golden Mignonette, white Lilies, annual Chrysanthemums, Calendulas, Larkspurs, and many other varieties of annuals, biennials, and perennials, which were admired by the Princess Christian.

— THE LATE THOMAS MOORE.—A memorial stone has been erected in Brompton Cemetery to the memory of this indefatigable worker in and for horticulture. It is of marble, with an appropriate device of Ferns and Stangeria. The inscription runs thus;—"To the memory of Thomas Moore, F.L.S., for thirty-eight years Curator of the Botanic Gardens of the Society of Apothecaries at Chelsea, who died January 1st, 1887, aged sixty-five years. In testimony of their appreciation of a career unselfishly devoted to the promotion of botany and horticulture, especially to the investigation and classification of Ferns as well as in grateful remembrance of his sterling qualities as a friend and a colleague, this memorial has been erected by a few of his fellow-workers." Those friends of Mr. Moore who have not yet sent their contributions are requested to do so without delay, either to Mr. Harry J. Veitch, King's Road, Chelsea; or to Dr. Masters at the office of the *Gardener's Chronicle*, 41, Wellington Street, Covent Garden, London.

— STRAWBERRY FARMING.—A correspondent, "G. B. H.," desires to know, "1, What would be considered an average season's crop of Strawberries from one acre of ground planted in beds 4 feet wide with paths 1 foot wide between them? The answer to be given in tons. 2, What is an average price per ton the boilers give to the growers for delivery free?" We will readily publish any replies that may be sent to us by persons who are able to impart the desired information.

— FLOWER SHOW AT THE PEOPLE'S PALACE.—On Monday and Tuesday last (July 25th and 26th) a Flower Show was held at The People's Palace, Mile End, which was visited by H.R. and I.H. the Crown Princess of Germany. The chief portion of the Show was formed of non-competing exhibits, but a few classes were provided in which the Beaumont Trustees offered prizes for plants grown in the East End. The principal exhibits were the following:—A large and handsome group of stove and greenhouse flowering and fine-foliage plants from Mr. B. S. Williams, Upper Holloway; a grand group of Tuberos Begonias from Messrs. Laing & Co., Forest Hill; an extensive collection of fresh and beautiful Roses from Mr. William Rumsey, Waltham Cross; a handsome group of annuals from Messrs. J. Carter & Co., High Holborn; a charming collection of Ferns and fine-foliage plants from Mr. H. B. May, Edmonton; an extremely large and varied collection of hardy flowers from Mr. T. S. Ware, Tottenham, and Messrs. Barr & Son, Covent Garden. Mr. E. Rivers, gardener to W. B. Bryan, Esq., Waterworks, Old Ford, was the leading prizetaker in the classes, but these exhibits were not very numerous. A large number of persons visited the Show, the charge

for a mission being 1d. and 2d. The Show was well arranged by Mr. William Earley.

— MR. R. H. VERTEGANS, Chad Valley Nursery, Birmingham, sends us flowers of two varieties of *Campanula carpatica* named Distinction, with dark blue flowers, and Chad Valley Gem, with pale blue flowers. He informs us "they were exhibited at the Rose Show in Birmingham last week and received first-class certificates. The habit of growth is decidedly that of *C. carpatica*, but in stature they are intermediate between that species and *C. turbinata*. They were both raised from home-saved seed. The flattened flowers, too, of the lighter variety are very marked when in growth."

— WE understand that the NATIONAL CARNATION AND PICOTEE SHOW (Northern Section) will be held at Manchester on August 5th.

— MESSRS. JOHN LAING & Co.'s (Forest Hill) employees, numbering about eighty, went for their annual outing on Friday last, 22nd, to Ramsgate by the South-Eastern Railway. The dinner, well served at "Grant's Hotel," was presided over by Mr. Laing, supported by his two sons and the heads of the various departments. Afterwards a most enjoyable afternoon was spent by all. The party returned home in the evening by express train, all highly delighted with the day's enjoyment.

— THE GARDENERS' ORPHAN FUND.—The first meeting of the Committee of this recently established Fund was held on Monday evening last at 126, King's Road, Chelsea. There was a large attendance. The subscriptions and donations now amount to £1020. Mr. G. Deal was unanimously elected Chairman of the Committee, and letters were read from gentlemen in acceptance of the position of Vice-Presidents. The rules were finally revised and ordered to be printed, and bankers (the London and County) appointed. A sub-Committee, comprising Messrs. Dean, Roberts, Roupell, H. Williams, Woodbridge, Wright, and Wynne, was formed to nominate local secretaries and prepare methods of procedure, to be submitted to a meeting to be held at South Kensington on August 9th. A confident tone pervaded the meeting, and the Committee were relieved from any anxiety as to the disbursement of the fund by an application on behalf of the family of a gardener who died suddenly in Sussex. This first appeal was filed for consideration when the time arrives for distributing the benefits that may be at the disposal of the Committee. All contributions and communications respecting the Fund should be addressed to Mr. A. F. Barron, Royal Horticultural Society's Gardens, Chiswick, London.

— WE are informed that the NATIONAL DAHLIA SHOW will be held at the Crystal Palace on September 2nd and 3rd, and subscriptions are desired from persons who are interested in the culture of the Dahlia to meet the necessary expenditure. Mr. Henry Glasscock, Rye Street, Bishops Stortford, is the Honorary Secretary and Treasurer, and to whom communications should be addressed.

— WE are requested to state that Mrs. Hornby and her gardener, Wm. Smith, have removed from Alvastou House to The Hawthorns, Welsh Row, Nantwich.

— CARLTON-IN-LINDRICK (NOTTS) ROSE SHOW.—A correspondent writes that—"The second annual Show was held on Thursday, 21st inst., in the schoolroom in the village. Taking into account the very dry season, the exhibits were good, and some fair boxes were staged. The principal awards were as follows:—Twenty-four blooms: First, Mr. Frettingham; second, Mr. Mallinder, gardener to Mrs. Mellish, Hodsock Priory. The best H.P. and best Tea in the class, Mr. Frettingham. Twelve blooms, amateurs: First, Mr. Fisher, Seawby, Brigg. This box was decidedly the brightest and best in the Show. Second, Mr. Mallinder. Six Teas: First, Mr. Mallinder. Best Rose in the class, Mr. Fisher. Six Roses grown with Beeson's manure: First, Mr. Mallinder. The competition in the cottagers' and local classes was keen, although the staging of the blooms left something to be desired. Mr. Duncan Gilmour, jun., and Mr. Wilson of Handsworth gave satisfaction as Judges. Mr. Gilmour had a beautiful box of Teas, and some splendid examples of Her Majesty, which were much admired. Mr. Machen of Gateford Hall sent a box of the Maiden's Blush Rose and Messrs. Fisher & Co. of Handsworth also sent Roses."

— THE proceedings at the usual weekly meeting of the members of the WAKEFIELD PAXTON SOCIETY held at the Saw Inn were unusually interesting. It was the date fixed for the annual Rose Show.

and a grand display of the queen of flowers was made both as regards quantity and quality. The flowers were shown by nurserymen, gentlemen's gardeners, and noted rosarians. Messrs. Calam of Heath Nursery, who are extensive and successful Rose growers and exhibitors, showed a stand of twenty-four magnificent Roses, and they were greatly admired. The flowers staged by some of the amateurs were remarkably fine, particularly a collection shown by Mr. George Bott, schoolmaster, Walton, who has for the past quarter of a century devoted considerable attention to the cultivation of this favourite flower. Mr. H. Oxley, one of the Vice-Presidents, occupied the chair, and Mr. Bott acted as Vice-Chairman. There was a large attendance of the members, together with the President and several of the members of the Morley Paxton Society, and Mr. S. Ballinger, of Elmhirst, Barnsley, Honorary Secretary to the Yorkshire Association of Horticultural Societies. A long and most interesting discussion then took place on "The Rose." The discussion was opened, by request, by Mr. Ireland, head gardener to Baron St. Oswald, of Nostell Priory, and he gave some valuable advice as to how to grow Roses in beds for exhibition purposes. A large number of questions were put to Mr. Ireland with respect to pruning and budding Roses, &c., dealing with mildew, fly, all of which he promptly, fully, and clearly answered. At the close of the discussion, in which Messrs. Simpson (Walton), Fenner (Sandal), Garnett, and others took part, the President of the Morley Society expressed their thanks to the Wakefield Society for the assistance and advice they at Morley had received, and he also said they had been pleased with the grand display and the interesting discussion that evening. On the motion of Mr. B. Whiteley, seconded by Mr. Hugo Green, a very hearty vote of thanks was given to Mr. Ireland for opening the discussion and answering questions, and to the exhibitors for the beautiful display of Roses.

## ROSE SHOWS.

CHRISTLETON.—JULY 18TH.

In the grounds attached to the charming rectory of Christleton, which the Rev. Lionel Garnett threw open for the use of the Rose Society, the annual Show of this Society was held under the most favourable auspices. The weather was all that could have been desired, the rain of the previous day had cooled the air and refreshed the ground, a nice breeze tended still further to the comfort of those who frequented the Show, while the Exhibition itself, although not extensive, contained some really excellent blooms, and to many of us an additional feature of great interest was added in the prizes offered for hardy cut flowers. The rectory garden is well known for its valuable collection of herbaceous plants, and in the neighbourhood generally there is an evident healthy taste in this direction, as no less than nine collections were set up by amateurs in the classes for thirty-six, twenty-four, and twelve varieties.

Like many other exhibitions, Christleton felt the effects of this most disappointing Rose season. It has been a great difficulty, for small growers especially, to get blooms fit for exhibition owing to the intense heat and the very rapid manner in which flowers developed, the bud of the morning being fully expanded and gone by night; nevertheless, as I have said, some very excellent stands were shown. In the nurserymen's class Messrs. Mack and Son of Catterick Bridge, and the two firms of Dicksons of Chester competed in the class for thirty-six distinct, single trusses, the first prize being awarded to Messrs. Mack & Son for a good stand consisting of the following flowers:—Duc de Rohan, Etienne Levet, Pierre Notting (a fine bloom), La France, François Lacharme, Duc de Wellington, Pride of Waltham, Cha les Lefebvre, Comtesse de Serenye, Alfred Colomb, Baroness Rothschild, Countess of Rosebery, Dr. Andry, François Louvat, Benoit Comte, Niphotos, John Stuart Mill, François Fontaine, Horace Vernet, Duchesse de Vallombrosa, Prince Humbert, Marie Verdier, Barthelemy Joubert, Marie Rady, Le Havre, Merveille de Lyon, Madame Gabriel Luizet, A. K. Williams, Emilie Hausburg (very fine), Louis Van Houtte, Exposition de Brie, Lady Sheffield, Marie Banmann, Earl of Pembroke, Lord Macaulay, and Catherine Mermet. This was the only class open to nurserymen.

In the amateurs' classes the first prize for twenty-four single blooms, distinct, was taken by T. B. Hall, Esq., Rockferry, Birkenhead, with a very good collection of flowers of the following varieties:—Innocente Pirola, Alfred Colomb, A. K. Williams, Baroness Rothschild, Beauty of Waltham, Captain Christy, Charles Darwin, Comtesse de Camando (a very fine flower), Comtesse de Serenye, Duke of Edinburgh, Duchess of Bedford, Emilie Hausburg, Etienne Levet, Fisher Holmes, Horace Vernet, John Stuart Mill, Julius Finger, Madame Charles Crapelet, Madame Gabriel Luizet, Marie Rady, Merveille de Lyon, Paul Neyron, Prince Arthur, and Star of Waltham. These were some of the best flowers I have ever seen. Mr. Hall stage, and it is remarkable how some of the flowers have come to the front this year. Comtesse de Camando, Prince Arthur, and Emilie Hausburg have especially, wherever shown, been very fine, and I have no doubt these varieties will be looked up for another year. Mr. C. J. Day was a good second, and the Rev. Lionel Garnett third. In the class for twelve distinct the first prize was taken by Colonel Standish Hore of St. Asaph with good blooms of Alfred Colomb, Etienne Levet, Fisher Holmes, Baroness Rothschild, Marie Rady, Eugene Verdier, Princess of Wales, Star of Waltham, and Francisca Kruger. In the class for six blooms Colonel Hore was again first with Abel Carrière, Alfred Colomb, Charles Darwin, Beauty of Waltham, Hon. Edith Giffard, and Louis Van Houtte. In the class for twelve blooms of any one Rose the first prize was won by C. J. Day, Esq., with Innocente Pirola. In the class for twelve Teas or Noisettes Mr. Day also won the first prize with fresh but not large blooms of Madame de

Watteville, Innocente Pirola, Maréchal Niel, Niphotos, Caroline Knster, Souvenir d'un Ami, Rubens, Catherine Mermet, Madame Lambert, Comtesse de Nadaillac, Madame Bravy, and a pretty bloom of Sunset. In the class for six distinct Teas or Noisettes, the first prize fell to the Rev. Lionel Garnett for Francisca Kruger, Catherine Mermet, Souvenir de Thérèse Levet, Hon. Edith Giffard, Marie Van Houtte, and Comtesse de Nadaillac.

The division allotted to cut flowers of hardy perennials was a very interesting one, and many of the flowers shown manifested a high class of cultivation, as well as being in themselves beautiful. The first prize in the collection for not more than thirty-six varieties was awarded to the Rev. Lionel Garnett for a very beautiful stand, consisting of the following varieties:—Lilium testaceum, Lilium croceum, Lilium pardalinum, Lilium longiflorum, Galea officinalis, Pentstemon barbatus, Pentstemon Cobœa, Potentilla Dr. Andry, Coreopsis lanceolata, Phlox Lady Napier, Gladiolus cardinalis, Gladiolus Colvillei (The Bride), Gladiolus insignis, Eryngium amethystinum, Centaurea macrocephala, Campanula persicifolia fl.-pl., Doronicum plantagineum exce'sior (or Harpur Crewe), Iris Kämpferi, Alstrœmeria chilensis, Lychnis Hægeana, Campanula Hendersoni, Gaillardia grandiflora, Catananche cœrulea, Chrysanthemum maximum, Campanula sarmatica, Delphinium sinense, Scabiosa caucasica, finer than I ever recollect seeing it; Gaillardia aristata, Platycodon grandiflorum, Bupthalmum salicifolium, and a very beautiful light blue seedling Delphinium, Crinum capense. The second prize was awarded to J. Garnett, Esq., Wyre Ride, Lancaster, and the third to Mrs. Townsend Ince. In the class for twenty-four, the first prize was awarded to Mrs. T. Ince for a very good stand containing Delphinium Mons. de Bihan, Delphinium grandiflorum plenum, Delphinium Cantab, Achillea ptarmica fl.-pl., Iris Kämpferi Rutherford Alcock, Lilium testaceum, Lilium candidum, Pentstemon Hartwegi coccinea, Spirœa Filipendula, Phlox Mrs. McKeller, Lychnis chalcœdonica, Lilium auratum, Campanula persicifolia alba, Coreopsis lanceolata, Lathyrus Sibthorpi, very pretty and sweet-scented; Pink Mrs. Sinkins, Gladiolus insignis, Spirœa palmata elegans, Gladiolus Queen Victoria, Alstrœmeria chilensis, Geranium pratense fl.-pl., Gnothera Youngi, and Lathyrus latifolius albus. In the collection for twelve, annuals were admitted, and three pretty groups were staged.

Messrs. Mack & Son exhibited a box of a new seedling Rose called Duchess of Leeds, a cross between La France and Prince Camille de Rohan, retaining, however, no trace of the latter parent. It is something of the colour of Marie Finger, not large, very floriferous, and sweet-scented. It will probably make a good bright garden Rose, but I doubt its coming into the list of exhibition Roses. They also showed some blooms of their new seedling Sir Rowland Hill, but not in as good form as it was shown at Edinburgh.

There was a necessity for the Show being held on Monday, and this doubtless prevented several from a distance from coming, and thus, with the very trying season, made the entries less numerous than usual; but in a neighbourhood like this, where there are good growers such as the Messrs. Jas. Dickson and Messrs. F. and A. Dickson & Sons, and such amateurs as the Rev. Lionel Garnett and Mr. Day, the love of the Rose is sure to be kept alive, and I hardly know a more attractive little show than this of Christleton, or one which is so thoroughly well carried out.—D., Deal.

WIRRAL.—JULY 20TH.

SINCE the day, some years ago, when I put the geographical puzzle before the readers of the Journal as to the locality where the Show was to be held it has passed through many vicissitudes. It has changed its name more than once; it has held shows where the collections of Roses were numerous, and where the most celebrated growers, both amateur and professional, have exhibited, but where the flowers far outnumbered the visitors. It has had a tolerably good experience of what a rainy day can do to damage the best laid plans; it has had often to tell of funds falling short and of exhibitors being disheartened, but still it has held on its way, and probably in one sense, and that a very important one, it has never had a greater financial success than in the show of the present year. It must, however, be frankly confessed that the competition fell far short of what was anticipated and hoped for. Like all other Rose shows, the influence of the very hot weather we have experienced told heavily on many who have always put in an appearance, and when I say that amongst nurserymen neither Paul, B. R. Cant, F. Cant, Cranston, or Prince were represented, and that there was only one exhibitor in the classes for seventy-two singles and eighteen triplets, it will be readily seen how much it suffered. Amateurs were better represented, although there was also a falling off here: still I think that it was a surprise to many, especially to those who grow Roses themselves, that such excellent blooms should have been staged.

The Exhibition was held in Hamilton Square, Birkenhead, where it has been held for the last two years, and is unquestionably the most suitable place for it of any that have been made use of. The surroundings perhaps are not so pretty as those of Birkenhead Park, but it is more manageable, not interfered with by other things, and near to the railway station and the ferry for Liverpool. The arrangements were well carried out, and the comfort and convenience of visitors well provided for.

In the larger classes for nurserymen Messrs. Harkness & Sons, the champion growers of the year, were the only exhibitors; their blooms were wonderfully fresh and good, and consisted of the following flowers, those marked with an \* being especially fine:—Marie Baumann, \*Dr. Sewell, Paul Neyron, Countess of Rosebery, Princess Beatrice, Prince Camille de Rohan, Madame Thérèse Levet, Ulrich Brunner, Alfred Duménil, Dr. Andry, François Michelin, Le Havre, Merveille de Lyon, Auguste Rigotard, Baroness Rothschild, Madame Hausmann, Queen of Queens, Abel Carrière, Duchesse de Morny, Alfred Colomb, Heinrich Schultheis, Comtesse de Serenye, Etienne Levet, Magna Charta, Charles Darwin, Madame de Watteville, Horace Vernet, Jean Ducher, Duc de Rohan, Maréchal Niel, Duc de Wellington, \*Emilie Hausburg, Prince Arthur, Souvenir d'un Ami, Dupuy Jamain, Marie Finger, Devienne Lamy, Madame Eugène Verdier, Madame Victor Verdier, Mons. E. Y. Teas, Marie Verdier, Madame Bravy, Marie Rady, Dr. Sewell, Captain Christy, Charles Lefebvre, Caroline Swales, La France, \*Fisher Holmes, Pride of Waltham, \*Lord Macaulay, Duchess of Edinburgh, \*Duke of Connaught, Madame Gabriel Luizet, Lady Sheffield, Lady Mary Fitzwilliam, Gloire de Bourg la Reine, Penelope



Mayo, Rosieriste Jacobs, John Hopper, Ann'e Wood, Duchesse de Vallambrosa, Thomas Mills, Her Majesty, Louis Van Houtte, Duke of Albany, Marquise de Castellane, Duchess of Bedford, Mrs. Jowitt, Reynolds Ho'e, and A. K. Williams.

In the class for thirty-six trebles Messrs. Harkness & Sons were again the only exhibitors. They had a fine stand, consisting of Devienne Lamy, Louis Van Houtte, Magna Charta, Dr. Andry, Marquise de Castellane, Etienne Levet, Dupuy Jamain, Charles Lefebvre, Antoine Ducher, Alfred Colomb, Emilie Hausburg, H. Vernet, Merveill de Lyon, Marie Baumann, Comtesse de Serenye, Countess of Rosebery, Prince Arthur, and Auguste Rigotard, Lord Beaconsfield, La France, Madame Lacharme, Mdlle Therese Levet, Fisher Holmes, Charles Darwin, Marie Finger, Mons. E. Y. Teas, Pierre Notting, Baroness Rothschild, Marie Rady, Souvenir d'un Ami, Prince Arthur, Queen of Queens, Dnke of Wellington, Niphetos, A. K. Williams, and Marie Baumann.

In the class for thirty-six blooms, single trusses, the competitors were Messrs. James Dickson & Sons, Messrs. F. & A. Dickson & Sons, and Mr. W. H. Burch of Co'chester, and the prizes were awarded in the order named. Messrs. James Dickson & Sons' flowers were Madame Eugenie Verdier, Madame Ducher, Comtesse de Serenye, Camille Bernardin, Pride of Waltham, Pierre Notting, François Michelon, Prince Camille de Rohan, Baroness Rothschild, Marie Baumann, Comtesse d'Oxford, A. K. Williams, Alfred Colomb, Dupuy Jamain, Duchess of Bedford, Niphetos, Madame Victor Verdier, Mrs. Baker, Charles Darwin, Marie Finger, Comtesse de Camando, Merveille de Lyon, Charles Lefebvre, Star of Waltham, Captain Christy, Abel Carrière, Nardy Frères, Horace Vernet, Paul Neyron, Xavier Olibo, Emilie Hausburg, Sénateur Vaisse, Catherine Mermet, Duc de Rohan, Gabriel Luizet, and Duc de Wellington. In the class for eighteen trebles the same competitors entered, and Messrs. James Dickson & Sons were again first with Alfred Colomb, Pride of Waltham, Pierre Notting, Comtesse de Serenye, Marie Baumann, Comtesse d'Oxford, Sénateur Vaisse, Madame Eugenie Verdier, Earl of Pembroke, Magna Charta, Rosieriste Jacobs, Baroness Rothschild, Charles Darwin, Madame Victor Verdier, Mons. E. Y. Teas, Madame Gabriel Luizet, Horace Vernet, Merveille de Lyon.

In the amateurs' classes, the Rev. J. H. Pemberton of Havering-atte-Bower was first with Comtesse d'Oxford, Marie Finger, Mons. E. Y. Teas, La France, Duchess of Bedford, Countess of Rosebery, Pride of Waltham, Beauty of Waltham, Madame Eugenie Verdier, Horace Vernet, Auguste Rigotard, Comtesse de Camando, Dr. Andry, Madame Caroline Kuster, Pierre Notting, Souvenir d'un Ami, Earl of Pembroke, Comtesse de Nadaillac, Annie Laxton, Madame Alfred Vigneron, François Michelon, John Stuart Mill, Etienne Levet, Charles Lefebvre, Louis Van Houtte, Etoile de Lyon, A. K. Williams, Captain Christy. Baron Nathaniel de Rothschild, Ulrich Brunner, Helen Paul, Alfred Colomb, Abel Carrière, Devienne Lamy, Niphetos, and Harrison Weir. Mr. T. B. Hall, of Lambwood, was a good second. In the class for twenty-four distinct Mr. Byes, of Derby, was well first with clean and fresh blooms of Pierre Notting, Maréchal Vaillant, Comtesse d'Oxford, Sir Garnet Wolseley, Baroness Rothschild, Star of Waltham, Marie Baumann, Magna Charta, Devienne Lamy, Baron de Bonstettin, Mrs. Charles Wood, Comtesse de Serenye, Duke of Wellington, La France, Duke of Connaught, Dr. Andry, A. K. Williams, Le Havre, Souvenir d'Elise Vardon, Paul Jamain, Prince Camille de Rohan, Camille Bernardin, Madame Gabriel Luizet, and Dingé Conard. Mr. J. Backhouse was second, and Mr. W. J. Grant third. In the class for twelve trebles, Mr. Pemberton was again first with Duchess of Bedford, Niphetos, Captain Christy, Alfred Colomb, Caroline Kuster, John Stuart Mill, Beauty of Waltham, Marie Finger, Horace Vernet, Etoile de Lyon, Magna Charta, and A. K. Williams. Mr. T. B. Hall was a good second, and amongst his flowers was a beautiful triplet of Duchess of Bedford. In the class for twelve Teas, the Rev. J. H. Pemberton was again first with Catherine Mermet, Etoile de Lyon, Souvenir d'un Ami, Niphetos, Maréchal Niel, Innocente Pirola, Caroline Kuster, Madame de Watteville, Madame Hippolyte Jamain, Comtesse de Nadaillac, and Souvenir de Thérèse Levet. Mr. T. B. Hall was second, and the Rev. Lionel Garnett third. In the class for twelve blooms of any light Rose, the prize fell to T. B. Hall, Esq., for Captain Christy.

The local classes always excite a good deal of interest at Wirral, and it was especially so in the class for twenty-four for amateurs, in which the gold medal of the National Rose Society was awarded. This was won by A. Tate, Esq., with a very good box of the following flowers—Marie Baumann, Dr. Andry, John Stuart Mill, Paul Neyron, Comtesse d'Oxford, Madame Sophie Fropot, François Michelon, Merveille de Lyon, Annie Wood, Général Jacqueminot, Baroness Rothschild, Louis Van Houtte, Madame Victor Verdier, Alfred Colomb, Victor Verdier, Madame Lacharme, Sir Garnet Wolseley, Etienne Levet, Comtesse de Serenye, Xavier Olibo, Captain Christy, and Rosieriste Jacobs. In the class for twelve, a cup presented by T. B. Hall, Esq., was won by S. Desborough Walford, Esq., with Victor Verdier, Marie Baumann, Captain Christy, Ulrich Brunner, Marie Rady, Hippolyte Jamain, Paul Neyron, Pierre La France, François Michelon, Sultan of Zanzibar, and Baroness Rothschild. The box was unfortunately covered with velvet, and as the dry wore on the Roses, missing the cool freshness of the moss, succumbed very quickly. Dr. Bell was a good second, and his Roses improved as the day went on. This was to be won by an exhibitor who had never gained the gold or silver medal of the National Rose Society. In the class for six the prize was awarded to Miss Squary for neat blooms of Merveille de Lyon, Dr. Andry, Duchess of Bedford, Etienne Levet, and Annie Wood. The second was awarded to Mr. C. R. Hall. In the class for twelve Mr. E. Claxton was first with Madame de Watteville, Princess of Wales, Souvenir d'un Ami, Madame Cusin, Niphetos, Francisca Kruger, Madame Lambard, Madame Villermoz, Marie Van Houtte, Madame Hippolyte Jamain, Souvenir de Thérèse Levet, and Alba Rosea. Mr. T. B. Hall was second. In the class for six Teas, Canon Fielder, Bebington Rectory, was awarded the first prize for a very good box of Maréchal Niel, Jean Ducher, Comtesse de Nadaillac, Niphetos, Catherine Mermet, and Mdlle. Lambard. The bronze medal of the National Rose Society was awarded to a bloom of Maréchal Niel in this stand, and another to Mr. T. B. Hall for a grand bloom of Camille Bernardin.

Messrs. Johnson and Henderson exhibited two very excellent groups of miscellaneous plants, and also some plants for the latter; these added to the general effect, and were much admired. The officers of the Society did their

utmost to make everything agreeable to the exhibitors, and all passed off exceedingly well and with good financial results.—D., Deal.

#### LEEK.—JULY 19TH.

ON Tuesday the fourteenth Exhibition of the Leek Rose Society was held in the Town Hall under National rules. Owing, however, to the terrible weather we have had during the last two months, the Show was—to say the very least—very disappointing, the flowers lacking not only the number but the size and substance of previous years. It is only fair to state that under the exceptional circumstances no other result was possible. Still, the Show resembled to only a very limited extent the preceding ones. The entries numbered fifty, and the competitors were only two less than last year, the absentees preferring the profit of sending their blooms to market to the honour of winning prizes at Leek. It was additionally disappointing to find that the famous Highfield plants, which have hitherto done so much to make the Show a success, were entirely absent; and it is to be regretted that the Exhibition at Kildgrove should have been preferred before that of Leek. The plants, however, from Westwood were exceedingly well grown and finely flowered, amongst them being Allamanda cathartica, Clerodendron Balfourianum, a grand Baron James Rothschild Croton, Bougainvillea glabra with its wealth of mauve flowers, and Allamanda Hendersoni with its bright yellow blooms. The eight which took the second prize came from Mr. Round's conservatory, Cheddleton, but were of a far less pretentious character than those we have mentioned, including among their best a large Maidenhair Fern and a well-flowered Hydrangea. The Ferns were exceedingly fine, as were also the Fuchsias from Westwood; indeed, their condition and beauty were so admirable that we give their names—Venus de Medici, Maid of Honour, Sir Colin Campbell, Symbol, Wave of Life, and Alton.

Coming to the Roses, we found in Mr. J. Gilman's winning stand of twenty fours excellent blooms of Merveille de Lyon, A. K. Williams, Duc de Rohan, Beauty of Waltham, Charles Lefebvre, Alfred Colomb, and Marie Rady. In addition to the money prize Mr. Gilman takes the National Society's silver medal. Mr. Sheldon's flowers, too, were good, clean, and well set up, and included François Michelon, Star of Waltham, Baron Bonstettin, Marquis de Castellane, Louis Van Houtte, and Madame Hippolyte Jamain. Mr. Nixon's were small but good, especially Louis Van Houtte, Baroness Rothschild, and La Rosière. In eighteens Mr. Gilman's collection again won easily, the chief blooms being La France, Louis Van Houtte, Mons. E. Y. Teas, Mdlle. Marie Rady, and Etienne Levet. Mr. Cosgrove was second with a very satisfactory exhibit, in which the Judge found the premier Rose in the Show, and awarded to it the National Society's bronze medal. This bloom was Mrs. Jowitt, and appropriately enough it is a Staffordshire-bred variety, having been raised by a Mr. Bailey of Newcastle-under-Lyme, and sent out some years ago by Messrs. Cranston of Hereford. In the stand, too, were Merveille de Lyon, Sénateur Vaisse, Marie Baumann, and Star of Waltham. In apportioning the above prizes the Judge had little or no difficulty, but in twelve the competition was stronger and the task proportionately more difficult. Mr. J. Brunt, however, was clearly first, his stand including a grand specimen of that shy bloomer Captain Christy, Brightness of Cheshunt, and Marie Baumann, the latter running Mrs. Jowitt very close for the premiership. Mr. Capewell came second, showing good blooms of Baroness Rothschild, Etienne Levet, and Charles Lefebvre; Mr. S. Bratt was third with Camille Bernardin, E. Y. Teas, and Avocat Duvivier; and Mr. Holden fourth with Marie Rady, Duke of Edinburgh, and others. The sixes, dark and light, produced good contests, some of the stands being remarkably even in merit. For the more miscellaneous prizes there was not much struggling, the prizes in most cases exceeding the exhibits. As a whole, the Show was well arranged, and did credit to Mr. H. W. Nixon and the Committee, and the executive are to be congratulated upon the way in which they surmounted difficulties which would have overcome persons less indefatigable and determined. Mr. Mason, curator of Prince's Park, Liverpool, was the Judge, and the following is the

LIST OF PRIZES.—Roses.—Twenty-four distinct varieties (National Rose Society's silver medal). 1, James Gilman; 2, Paul Sheldon; 3, H. W. Nixon. Eighteen distinct varieties, 1, James Gilman, 2, Thomas Cosgrove. Twelve distinct varieties, 1, J. Brunt; 2, W. Capewell; 3, S. Bratt; 4, A. Holden. Six distinct varieties (H.P.), 1, S. Bratt; 2, A. Holden; 3, Joseph Brunt. Three distinct varieties, 1, James Bratt. Six distinct dark varieties (H.P.), 1, J. Garner, 2, J. Gilman; 3, P. Sheldon. Six distinct light varieties (H.P.), 1, J. Garner; 2, P. Sheldon; 3, J. Gilman. Twelve single blooms, 1, J. Gilman (Alfred Colomb). Six single blooms, 1, J. Gilman; 2, A. Holden. Premier bloom, 1, J. Cosgrove (Mrs. Jowitt). Four button-hole bouquets made of Roses, 1, P. Sheldon; 2, A. Holden. Basket of Roses, 1, P. Sheldon; 2, A. Holden. Bouquet of Roses, 1, P. Sheldon. Six Roses in pots, 1, J. Brunt.

Stove and Greenhouse Plants, &c.—Group of ten flowered or foliage, 1, A. Holden; W. Gildart, gardener to Mr. Round, Cheddleton. Six Ferns, 1, A. Holden; 2, W. Gildart. Six Fuchsias, 1, A. Holden. Centrepiece composed of Roses, 1, A. Holden; 2, W. Gildart. Hand bouquet, 1, A. Holden; 2, W. Gildart. Twenty-four Pansies, 1, A. Holden. Six button-hole bouquets, 1, W. Gildart; 2, A. Holden.

The Show was fairly well attended in the afternoon, and in the evening a large number of persons were present. Mr. T. Knight's band played selections of music at intervals in a highly creditable manner.—(Leek Times.)

#### NEW BRIGHTON ROSE SHOW.—JULY 16TH.

THERE is a unique feature about this Show that it is got up for the benefit of a local charity. A large-hearted doctor who has some very pretty grounds every year opens them for this purpose, takes the affair into his hands, entertains his friends, gives much encouragement to the people of the neighbourhood to come and see the Roses, witness a lawn tennis tournament, and listen to a good band. The result is that generally he contrives to raise a nice little sum for the purpose, and so St. George's Mount, Mr. Bell's residence, is well known to all Rose growers in this part of England. On last Saturday, favoured with a fine day and brilliant sunshine, a very pretty little Show was held and some really excellent blooms staged, despite the scorching and forcing heat of the weather of the previous week.

Nurserymen were invited to compete, and the invitation brought Messrs. Harkness & Son from Bedale, and the two firms of Dicksons from Chester, the former firm, as has been usual with them this season, taking the first prize. They had a very excellent stand, consisting of the following flowers:—Auguste Rigotard, Marie Rady (a grand bloom), Marie Verdier, A. K. Williams, Lady Mary Fitzwilliam, Star of Waltham, Louis Van Houtte, Ulrich Brunner, Alfred Colomb, Marquise de Castellane, Duke of Edinburg, Etienne Levet, Baroness Rothschild, Madame Haemann, Magna Charta, Charles Lefebvre, Lord Macaulay, Merveille de Lyon, Duke of Connaught (a large and grand bloom), Jean Ducher, Horace Vernet, Madame H. Jamain, Dr. Andry, Princess Beatrice, Marie Baumann (very fine bloom), Prince Arthur, Madame Gabriel Luizet, Général Jacqueminot, Sultan of Zanzibar, Alfred Dumesnil, Madame Victor Verdier, Duchesse de Morny, Duke of Teck, Beauty of Waltham, Captain Christy, Avocat Duvivier, Souvenir d'un Ami, Dr. Sewell, Innocente Pirola, Dr. Hooker, Charles Darwin (a grand bloom), Hippolyte Jamain, Fisher Holmes, Comtesse de Serenye (clean and good), Madame Willermoz, Penelope Mayo, Queen of Queens, and Duchess of Bedford.

The amateurs' classes contained some excellent blooms, the stand of

de Lyon, Marie Baumann, Alfred Colomb, Captain Christy and Charles Darwin.—D., Deal.

### GROUPS OF PLANTS AT SHOWS.

IN recent years a most important feature has been developed in the leading provincial and many local shows—namely, the groups of plants arranged for effect. They constitute classes of much interest both to horticultural visitors and the general public, besides giving many gardeners an opportunity of exhibiting who could not enter the classes devoted to specimen plants. It is not an unusual circumstance to find at provincial shows that a large tent is required to contain the competing groups, and where there is much local interest in this portion of the show it is found convenient to have two or more classes, so as to include as many would-be exhibitors as possible.

Remarkable as the progress has been in the past ten years, there is still room to encourage the group department of exhibitions to a greater

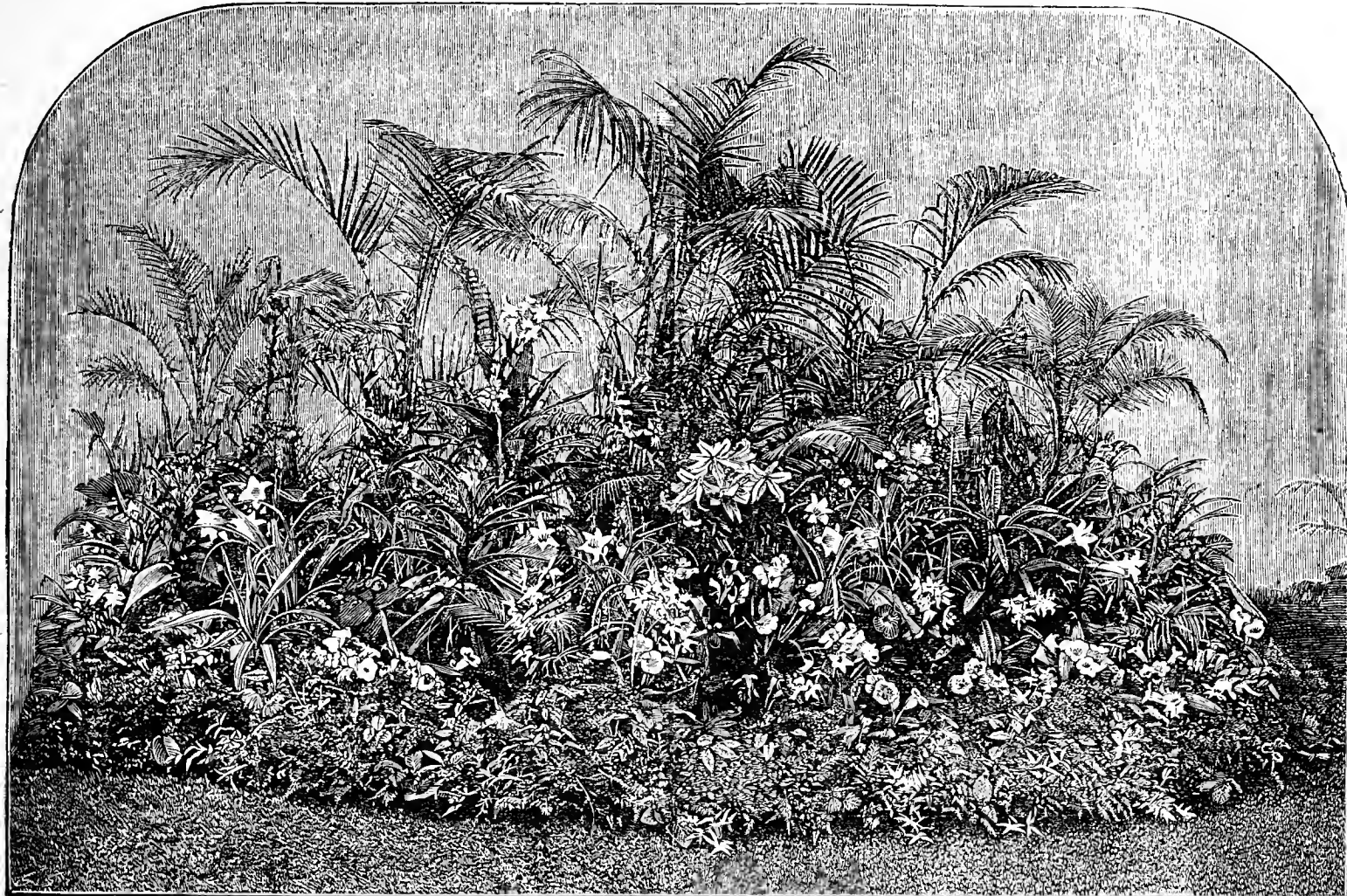

Fig. 8.—THE CHALLENGE CUP GROUP AT CHISWICK.

twenty-four exhibited by T. B. Hall, Esq., of Larkwood, Rockferry, having some of the freshest and best blooms I have seen this year, reminding me of those exhibited by E. B. Lindsell, Esq., at Hitchin; for this the gold medal was awarded. The flowers were Dupuy Jamain, Madame Hippolyte Jamain, Ulrich Brunner, Prince Arthur, Baroness Rothschild, Marie Rady, Alfred Colomb, Fisher Holmes, Comtesse de Camando, a grand bloom of a Rose that deserves to be more grown; A. K. Williams, Captain Christy, François Michelin, Charles Lefebvre, Marie Finger, Countess of Rosebery, Mrs. Laxton, Merveille de Lyon, Duc de Rohan, Marie Baumann, Duchesse de Vallombrosa, Emilie Hansburg, Camille de Rohan, Queen and Star of Waltham. The Rev. Lionel Garnett was second. In the class for eighteen Mr. Hall was again first with Captain Christy, Hippolyte Jamain, Dupuy Jamain, Duchesse de Caylus, François Michelin, Merveille de Lyon, Comtesse de Camando, very fine; Baroness Rothschild, Marie Baumann, Innocente Pirola, John Stuart Mill, Star of Waltham, Marie Rady, E. Y. Teas, Emilie Haushurg, Fisher Holmes, Comtesse de Serenye, and Duke of Connaught.

Mr. Hall was also first for twelve Teas, Souvenir d'Élise, Étoile de Lyon, Innocente Pirola, Marie Van Houtte, President, Jean Ducher, Perle des Jardins, Edith Giffard, Comtesse de Nadailac, Madame de Watteville, Anna Ollivier, and Francisca Kruger.

In the class for twelve, Mr. W. C. Hall was first with Marie Finger, Alfred Colomb, Captain Christy, Rosieriste Jacobs, Prince Arthur, Madame Hippolyte Jamain, Camille Boardin, François Michelin, Louis Van Houtte, Jules Finger, and Dr. Andry; in the class for six with Marie Baumann, Annie Wood, Dr. Andry, Alfred Colomb, Marie Finger, and La France. In the open class for six Mr. C. E. Hall was first with Etienne Levet, Merveille

de Lyon, and recognising this the Chiswick Horticultural Society, with the assistance of an earnest supporter, were enabled this year to offer a prize of exceptional value. Mrs. S. A. Lee, with most commendable generosity, offered a Jubilee challenge cup of handsome design, value twenty-six guineas, for the best group of plants arranged for effect in a space of 100 square feet, the winner to retain the cup for the year, but before it becomes the property of any exhibitor it must be won three times, not necessarily consecutively. In addition sums of £4, £3, £2, and £1 were contributed by the Society as first, second, third and fourth prizes. It might have been expected that such a class as this would have brought a large number of competitors, but whether it was not sufficiently known, or exhibitors suddenly became troubled with an unusual timidity, we cannot say, but only three groups were staged, a number that we hope to see doubled or trebled next year.

The first honours, the challenge cup and £4 prize, were, after a careful consideration of the respective merits of the groups entered, awarded to Mr. W. Brown, St. Mary's Grove Nursery, Richmond, who is well known in the district, and has repeatedly shown his skill in arrangements at the Richmond Exhibition. An illustration of this group (fig. 8), prepared from a photograph, gives some idea of the general style, but it is impossible in black and white to do full justice to such a bright and effective production. Mr. Brown owed his success mainly to the even balance of foliage and flowers in his collection, the



careful avoidance of all formality in arrangement, and the extremely neat finish imparted by the pleasing margin. In the background were a few Palms and Dracaenas, several well-coloured Crotons, and a groundwork of *Caladium argyrites* and *Adiantum cuneatum*, from which arose graceful plants of *Eulalia japonica variegata*, the edge being formed of *Panicum variegatum*, *Fittonias*, *Caladium argyrites*, and the elegant Fern *Onychium japonicum*, which was turned out of its pots and placed flat on the turf between the other plants. Colour was imparted by the following flowering plants:—*Gloxinias*, a few scarlet *Gladiolus* at the back, *Carnations*, *Tuberous Begonias*, blue English *Iris*s, and the bright red *Clerodendron fallax*. Other flowering plants of lighter tints were *Lilium candidum*, *L. auratum*, *L. speciosum*, *L. longiflorum*, *Odontoglossum vexillarium*, *O. crispum*, and *Cypripediums*. These were disposed in a free and graceful manner, and though Mr. Brown had a formidable opponent in the winner of the second prize, he clearly merited the honours accorded him. It may be expected that the competition next year will be even more interesting, and it is not likely that the present winner will be allowed to retain the prize without a considerable struggle.

### FLAVOUR OF STRAWBERRIES IN 1887.

WHEN I planted Loxford Hall Seedling two years ago I did it in doubt. I was afraid my land was too heavy for it. However, the plants grew well, and last year, as I stated, the fruit gave great satisfaction, so I planted another quarter with the same variety instead of British Queen. Then I noted that, good as the old British Queen was, this Loxford Hall was superior, it could be eaten after British Queen. The habit of Loxford Hall is sturdy, leaves only of medium size and round; the fruit is exposed to the sun much more than any other Strawberry I grow. The fruit trusses are of medium size, yet push beyond the foliage. I am particular in noting this, for reasons to be stated presently. This is a late variety, even later than British Queen. They showed well for fruit again this season, and I anticipated a treat, but the fruits never swelled. They are only about half the size they should be, and are scalded. It is not a question of ripening, they will be no better. Some fruit I have marked for a fortnight, and they still remain in poor condition. Then the flavour is gone, they are quite tasteless and sour. To make sure of these being good I was not content with once top-dressing, I mulched them twice. Certainly the heat and drought have spoilt the fruit, but I did not suppose it would take all flavour away. I shall try them another year, and if I can obtain runners I shall plant a few in the shady places and note the result. British Queen, while not quite so much scalded, growing side by side under the same conditions, is uneatable. What appears strange to me is that President, though quite half the plants look dead, and the fruits are miserably small, has its flavour good. Sir Joseph Paxton has done the best of all; foliage here, without doubt, has done good, but I might say that the first gathered fruits especially, though the weather being so very hot, failed to colour at the points. Flavour is very fair.

For fine flavour this season I have none to equal *Vicomtesse Hericart de Thury*. These are grown in a shady position. They have no midday sun, and the rows are closer together than in my other varieties. The fruit is small, but with a powerful scent and flavour. I should suppose for preserving there is nothing to equal it. It would be interesting if "J. E." page 27, would try Loxford Hall Seedling another season. I am sure it is the season that is to blame, though this is the first time I ever knew abundance of sun and heat to be detrimental to flavour. The query is, Why should it affect the flavour of these two varieties in particular? I grow the bulk of my Strawberries for a late supply, and British Queen is at home here, the crop being very good, the fruit of good size. Loxford Hall seems equally at home. I enclose a few berries of each. You will see they are scalded quite as much on the under side as at the top, and the refreshing showers we have had apparently make no difference to swelling up of younger fruit. A row of *Pauline* sent me by a friend grew well and gave great promise, but though the plants are very vigorous, not one fruit has ripened. The Captain was the same. King of the Earlys is a very weak grower here, I did not hope for fruit; next year shall look forward to it doing well.—S. C.

[The fruits sent were just as described by our correspondent—inferior in appearance and quality.]

### ROYAL HORTICULTURAL SOCIETY.

JULY 26TH.

THE exhibits before the Fruit and Floral Committees, the competing collection for the special prizes with the *Carnations* and *Picotees* constituted an excellent show in the conservatory, which was nearly filled.

**FRUIT COMMITTEE.**—T. F. Rivers, Esq., in the chair. Present: Messrs. Warren, Veitch, Willard, Norman, Heywood, Saltmarsh, Woodbridge, Blackmore, Pitt, and Dr. Hogg. Mr. C. W. Cook, Rendcomb Park Gardens, sent a seedling Melon, called Cook's Perfection, but it was not of sufficient merit. Messrs. James Carter & Co. of High Holborn, exhibited two varieties of Tomatoes, one called *Blenheim Orange*, which is of a yellowish colour tinged with red, and the other *Sandwich Islands*, round, smooth, and deep red. Neither of them was considered superior to existing varieties.

Messrs. James Veitch & Sons exhibited a collection of fruit, consisting of Strawberry *Quatre Saisons*, Raspberry *Superlative*, Pears *Mlle. Solange*, Citron *des Carmes* and *Doyenné d'Été*, Peach *Alexandra*, and White *Joaneting Apple*. They also sent three Peach trees in pots of the variety

Alexander, grown as pyramids, one bearing over a dozen good fruits; also dishes of the following fruits—*Governor Wood*, *Cleveland Bigarreau*, *Imperatrice Eugénie*, *Elton*, and *Mammoth Cherries*, for all of which a vote of thanks was awarded. From the gardens of the Royal Horticultural Society came a dish of *Roseberry Gooseberry*, *Variiegated Black Currants*, and *Gloire de Sablons Currant*, to which a vote of thanks was awarded. Mr. Norman, The Gardens, Hatfield House, sent dishes of remarkably fine fruit of *Royal George Peach* and *Elrnce Nectarine*, to which a cultural commendation was awarded. Messrs. Paul & Son of Cheshunt, exhibited a collection of fifty dishes of *Gooseberries*, to which a vote of thanks was awarded. Mr. G. Clowes, Blackbrook, Newcastle, Staffs, sent a dish of green fruited variety of *Black Currant*, which he supposed to be a seedling, but which is a very old and worthless variety.

Messrs. Rivers & Son, of Savbridgeworth, sent a very interesting collection of thirteen dishes of *Peaches* and *Nectarines*, containing fine specimens of *Sea Eagle*, *Lord Palmerston*, *Nectarine Peach*, *Prince of Wales*, *Early Batrice*, and *Victoria Nectarine*, to which a vote of thanks was awarded. Mr. Rivers also exhibited a dish of *Early Rivers Cherry*, which had been ripe and hanging on the tree since the second week in June. Mr. T. F. Rivers also exhibited a seedling Peach and a seedling *Nectarine*, both of which were raised from the *Nectarine Peach*. Both had the singular shape of the parent, being quite conical, terminating in a long beak. The Peach is yellow fleshed, and the *Nectarine* is pale greenish yellow like *Victoria*, and both possessed good flavour. Mr. Marriott, of Skirbeck, Boston, sent a *Pea* called *Boston Hero*, which was passed.

**FLORAL COMMITTEE.**—Present: G. F. Wilson, Esq., F.R.S., in the chair, and Messrs. G. Duffield, H. Bennett, H. Herbst, J. Walker, W. Goldring, C. Noble, C. Pilcher, J. Dominy, H. Ballantine, H. M. Pollett, Thomas Baines, A. J. Lendy, J. O'Brien, E. Hill, G. Paul, J. Hodson, J. Fraser, R. Dean, Amos Perry, J. Douglas, Shirley Hibberd, and Dr. M. T. Masters.

An interesting group of plants was contributed from the Royal Gardens, Kew, comprising a large plant of *Phaius bicolor* with three spikes of flowers, the dark-coloured *Anguloa Ruckeri* var. *sanguinea*, the bright yellow stove climber *Adenocalymna nitidum*, several choice Ferns, *Mesembryanthemums*, *Stative Suworowi*, and some hybrid *Streptocarpus*, which were certificated. Messrs. H. Cannell & Sons, Swanley, had a large group of double *Tuberous Begonias*, all raised from seed this year, and comprising a number of very handsome varieties, which were mostly named after the members of the Floral Committee. Several of the varieties were selected for certificates, and a cultural commendation was awarded for the whole group. Mr. T. S. Ware, Tottenham, contributed a choice collection of hardy flowers, comprising *Poppies*, *Lilies*, *Japanese Iris*s, *Spiraea palmata*, *Gaillardias*, and numerous examples of bright and varied border *Carnations* (silver Banksian medal). Messrs. J. Carter & Co., High Holborn, exhibited a plant of the pretty yellow *Lily*, *Lilium Hansonii*. G. F. Wilson, Esq., F.R.S., Weybridge and Wisley, showed examples of *Eryngium giganteum*, which Mr. Wilson states is frequented by bees more than any other plant in his garden. Mr. Robertson Munro, Abercorn Nurseries, Edinburgh, sent flowers of *Matricaria inodora* fl. pl., together with an improved form named *Snowflake*. Mr. J. Blundell, Dulwich, was awarded a vote of thanks for a handsome collection of double *Hollyhocks*, representing many varieties. Mr. F. T. Smith, West Dulwich, showed four boxes of double *Hollyhocks*, rich and delicate in colour. The Rev. H. H. D'Ombra, Westwell Vicarage, Ashford, showed a flower of a hardy *Amaryllis* named *Bayard* (Souchet) from a plant which has been growing in the open ground for eight years unprotected, and has two scapes of four flowers each. Mr. Norman, The Gardens, Hatfield House, Herts, exhibited a grand plant of *Saccolabium Blumei* with four expanded spikes of flowers 12 to 16 inches long, and one spike undeveloped (cultural commendation).

Messrs. J. Veitch & Sons, Chelsea, showed flowers of their *Rhododendron* hybrids, also of several new forms, and a large flowered rich rosy-red *Begonia* named *Bismarcki*. Mr. W. Gordon, Twickenham, sent a plant of *Cypripedium Laurencianum*, in which the dorsal sepal was split into two lobes, only one petal was present, erect in the centre, taking the place of the dorsal sepal. R. J. Measures, Esq., Cambridge Lodge, Camberwell (gardener, Mr. Simpkins) exhibited plants of *Cypripedium javanico-superbium*, an interesting and valuable hybrid, a richly coloured variety of *Vanda tricolor*, *Cattleya Acklandiae*, *C. Schilleriana*, and a flower of *Cypripedium concolor*, with two lips. Messrs. James Dickson & Son, Chester, showed flowers of a distinct orange-buff coloured *Carnation*. Mr. R. Spinks, Horley, was awarded a vote of thanks for a *Carnation* *Pride of Horley*, a white variety with a few crimson streaks. Messrs. F. Sander & Co., St. Albans, showed plants of *Odontoglossum Harryanum*, the sepals and petals brownish, the lip beautifully veined with purple at the base and white at the top. Messrs. Paul & Son, Cheshunt, contributed a large collection of hardy flowers, including numerous *Pentstemons*, *Gaillardias*, *Everlasting Peas*, *Phloxes*, *Erigérons*, *Epilobiums*, *Lilies*, &c. Messrs. Hooper & Co., Covent Garden, were awarded a vote of thanks for a handsome collection of *Gloxinia* blooms, very bright in colours. Messrs. J. Green & Nephew, Victoria Street, had a collection of ornamental glasses and stands for flowers.

### PLANTS CERTIFICATED.

*Streptocarpus Watsoni* (Royal Gardens, Kew).—A hybrid between the large-leaved *S. Dunni* and *S. parviflorus*, raised at Kew in 1886. A pretty form, with small flowers produced in great numbers of a rosy purple colour. The leaves are very large, about 18 inches long and 8 inches broad.

*Streptocarpus Kewensis* (Royal Gardens, Kew).—A hybrid between *S. Dunni* and *S. Rexii*, the flowers resembling the latter parent in form and colour, but much more numerous; the leaves very large, like those in *S. Watsoni*.

*Tuberous Begonia Edelweiss* (H. Cannell & Sons).—A double variety, with solid handsome pure white flowers.

*Tuberous Begonia Major Lendy* (H. Cannell & Sons).—A double variety; flowers of good shape, of a soft salmon rose tint.

*Tuberous Begonia Shirley Hibberd* (H. Cannell & Sons).—A handsome double variety, with large full flowers of a soft blush tint.

*Carnation Alice Ayres* (T. S. Ware).—A border variety with white flowers, streaked with bright red. Very free and good.



**Carnation Gravetye Gem** (Mrs. Hole).—(Messrs. J. Dickson & Son, Chester). A showy variety, with orange buff flowers, very distinct and useful. This has been already named Mrs. Hole at Manchester.

**Odontoglossum Harryanum** (F. Sander & Co., St. Albans).—A very distinct and beautiful species, with long broad sepals and petals undulated at the margin, heavily blotched with dark brown; the lip is very large, expanded, yellow in the centre, richly veined with purple at the sides, and pure white at the upper part.

**SPECIAL PRIZES.**—Messrs. Sutton & Sons' prizes for three varieties of Peas brought seven competitors. Mr. H. Marriott, sen., Skirbeck, Boston, Lincolnshire, was first with Satisfaction, Royal Jubilee, and Duke of Albany, all very fine. Mr. E. G. Wiles, Edgcote Gardens, Banbury, was second; Mr. H. Marriott, jun., third; and Mr. C. J. Waite, Glenhurst Gardens, Esher, fourth. Messrs. Suttons' prizes for twelve pots of Mammoth Longpod Beans were won by Mr. Waite, Mr. G. Beckett, Amersham, and Mr. A. J. Sanders, Bookham Lodge, Cotham. For two Cabbages, Sutton's Allheart and Little Gem, the prizes were gained by J. Downey, Esq., The Shrubbery, Enfield, Mr. Beckett, and Mr. J. Waite. There were four entries.

Messrs. J. Carter & Co.'s prizes for the Heartwell Cabbage were gained by Mr. H. Marriott, Mr. C. J. Waite, and Mr. F. A. Beckett; the same firm's prizes for Leviathan Beans being won by Messrs. Waite, Beckett, and Timms.

Messrs. Webb & Sons' prizes for Emperor Cabbages were awarded to Messrs. Marriott and E. G. Wiles, and for a dish of Chancellor Peas to Messrs. Marriott, sen. and jun., and G. Burden, Birmingham.

### OLD v. YOUNG STRAWBERRY PLANTS.

THE present season has shown what a mistake it is to rely upon old Strawberry plants for producing a crop of fruit, for even where water has been abundant the crop has not been a tithe of what it should have been, whilst on plants which have not been planted much longer than ten months the crop has been much larger, and the fruit very fine for the season, and without artificial watering too. Old plants were seriously crippled during the past winter, and the dry weather has made them worthless. In "Notes and Gleanings," in last week's Journal, I notice that Messrs. Lovel & Son, the celebrated Strawberry growers, bear out the above in a striking manner. I have recommended the planting of young Strawberries during the summer for several years past, the reason being that I have always seen excellent results by so doing. Mr. Douglas, when at Loxford Hall, and now at Great Gearies, always carried out the practice, as by no other way could he obtain such fine crops of fruit. I have heard gardeners question the policy, but they might just as well question the policy of layering the runners in July, and gathering the crop from March until May, as is done when grown for forcing. Young Strawberry plants are always vigorous. At page 27, in last week's Journal, "J. E." condemns Loxford Hall Seedling; with us it is a fortnight later than Dr. Hogg, and of good flavour. James Veitch with us is also of good flavour, although not quite equal to Dr. Hogg, but it is earlier, which makes it valuable. The past tropical weather has been trying to the flavour of many Strawberries, as it brought them on too fast.—A YOUNG, *Abberley Hall Gardens, Stourport.*

### HORTICULTURAL SHOWS.

#### HIGHGATE.

THE Baroness Burdett Coutts, with her customary liberality, again placed her beautiful garden at Holly Lodge at the disposal of the Highgate Horticultural Society for their annual Exhibition, which took place on Thursday last, July 21st. It would be difficult to estimate the indebtedness of the Society for this privilege, but there is no doubt that a large majority of the visitors were as much attracted by the gardens as by the Show. Holly Lodge is situated on the slope of the elevated ridge extending from Highgate to Hampstead and opposite to Parliament Hill, which is to be transferred to the public. There are about fifty acres, but so well has the space been utilised, every advantage being taken of the position to render it as undulated and varied as possible, that it appears much larger than it really is. Trees, both evergreen and deciduous, have been freely planted to form bold clumps or shady avenues, shrubs are abundant, the lawns are well kept, and, notwithstanding the tropical heat experienced, are unusually fresh and green. Flower beds brighten several parts of the garden, a few of the conventional summer type, and numbers filled with old garden favourites, borders of herbaceous plants, Roses, and everything that can be desired either in foliage or flowers. The kitchen garden is well cropped, the vegetables, with liberal attention, are enduring the season's trial satisfactorily, and hardy fruits are abundant; indeed the excellent condition of the garden in all departments indicates the energy and skill devoted by Mr. Willard to its superintendence.

From several walks in the garden fine views are obtained across the great metropolis, and even from the meadow devoted to the show tents an extensive prospect is commanded, especially at the upper part. As already stated, the gardens, with the bands, constituted the chief attraction. The Exhibition itself was not so good as the district is capable of producing. There appears to be an absence of vitality that must be mainly due to an ill-judged narrow-spirited system of management, the forerunner of failure in most affairs. The Society, as the result of its last season's efforts, had a deficit of £50, and the bare spaces too noticeable on the stages in one tent may be considered chiefly due to this, and the encouraging statement in the schedule that, "Providing the Society is not in a position to pay the full amount of the prizes, a per-centage will be taken off sufficient to meet the deficiency." In such a state of things this Society should encourage the non-competing exhibitors as much as possible, as the contributions from these form an interesting portion of many important shows; but the disposition seems to be to discourage this, for at least one exhibitor was refused

permission to stage a small box of flowers, though there were yards of unoccupied space. Much of the success of local shows depends upon the societies possessing practical committees, and secretaries whose hearts are in their work, and upon the adoption of a progressive policy; those that wish to stand still soon find they are getting behind the times.

Two large tents were filled with the exhibits, one being devoted to gardeners' productions, the other to amateurs and cottagers. The gardeners' tent contained foliage and flowering plants, groups, cut flowers, fruit, and vegetables; the cottagers' exhibits consisting mainly of vegetables, model gardens, &c., which were capitally represented. Large non-competing groups of plants from Mr. B. S. Williams, Upper Holloway, and Messrs. Ontbush & Sons, Highgate, formed the most conspicuous portion of the large tent near the entrance. Zonal Pelargoniums, Caladiums, fine-foliage plants, Ferns were shown by several competitors, the principal prizes in the plant classes being won by Mr. J. Brooks, gardener to W. Reynolds, Esq., The Grove, Highgate; Mr. Calvert, gardener to G. Kent, Esq., Southwood, Highgate; Mr. Brittain, gardener to F. Reckitt, Esq.; and Mr. Shephert, gardener to S. S. Duval, Esq., South Grove House, Highgate. Mr. Brooks secured the majority of the first prizes. Mr. W. Brise, gardener to J. H. Lermitte, Esq., Knightons, Finchley, was first with six Orchids, neat plants of Masdevallias and Odontoglossums. In the stands of flowers Allamandas were employed with extraordinary freedom, and in some cases with very bad taste.

Fruit was fairly represented, Messrs. Brise and Calvert leading with black and white Grapes, the Baroness Burdett Coutts' special prize for a collection of hardy fruits being won by Mr. G. Agate, gardener to A. Taylor, Esq., Priory House, Southgate, who had eighteen dishes; Melons from Messrs. Agate, Brise, and Clarke; Peaches from Mr. Brittain, and a collection from Mr. Brise were also noteworthy. The best vegetables were staged by Messrs. Agate and Clarke.

#### LEWISHAM.

THE second annual summer Show of the Lewisham and District Floral Society was held on Wednesday and Thursday, July 20th and 21st, in the grounds of Riverdale, High Street, Lewisham, by permission of J. Wallis, Esq. This young Society was started by a few amateurs and enthusiastic florist friends, and is making some progress, though there is ample room for further development. Riverdale is a picturesque little garden, the river Ravensbourn passing through the grounds and expanding into a miniature lake, with a water-wheel and mill adjoining. Very notable on the bank of the river is a handsome Tulip Tree of noble proportions. The tents devoted to the exhibits were placed in a meadow at the lower portion of the garden, and it was found that three were required to hold the entries, two small ones for cut flowers, bouquets, &c., and the other of good size for plants. At one end of the latter was a large group of annuals and other plants in pots from Messrs. J. Carter & Co., High Holborn, tastefully arranged and effective. Messrs. Barr & Son, King Street, Covent Garden, also had an extensive and handsome collection of hardy flowers. Messrs. J. Laing and Co., Forest Hill, had a bright group of Tuberous Begonias, Dracenas, Caladiums, and Crotons. Amongst the competing exhibits we can only mention a few of the most noteworthy. Dr. Duke, The Glen, Lewisham, won first honours with a group of Orchids, comprising Odontoglossums, Cattleyas, Cypripediums, Barkerias, Oncidium, Brassias, &c., with Rivinas, Ferns, Caladiums, and Palms. Zonal Pelargoniums, Tuberous Begonias, Gloxinias, and Fuchsias were represented by several exhibitors. Mr. J. Balcombe, gardener to J. S. Rivolta, Esq., Blackheath Park; Mr. F. Hudd, gardener to F. Prior, Esq., Gordon House, Blackheath Park; Mr. C. Nunn, gardener to J. Soames, Esq., J.P., Greenwich Park; and Mr. H. A. Needs, Catford, were prizetakers in most of these classes. Mr. Balcombe had the best group, followed by Mr. W. Jeffery, gardener to W. J. Young, Esq., and Mr. Hudd. Roses were not first-rate, Mr. W. Rumsey had much the best stand. Bouquets, vegetables, and fruit do not call for any special comment.



#### KITCHEN GARDEN.

THE WEATHER AND THE CROPS.—We may again write of these. Since our previous notes appeared in this column rain has fallen, but the soil has by no means received a thorough soaking; and although it enabled us to plant out many of our Winter Greens, crops generally have not benefited very much, as it is almost as hot and dry as before the rain came, and the worst of it is our water supply has not yet increased. This is the greatest of all our troubles, and we are now devising means to remedy it. Pumps, as a rule, are not enough employed about vegetable gardens. In many cases the water has to be carried from a long distance, but by sinking a well here and there a copious supply can generally be secured in the very centre of the vegetable quarter. It pays as well to water vegetables as anything else. We have watered our August Peas very freely during July, and the result is a splendid promise. Others who have not done so have none, and two or three different sowings are coming in together, as the later ones are maturing prematurely.

CARROTS.—Large quantities of Early Horns have been used from a south border. The main crop of Intermediate Carrots has stood better than we anticipated. They are not very large as yet, but the tops are green and healthy, and the roots will grow large by degrees with such tops. It is when the tops cease growing and become yellow that the roots fail to swell satisfactory; and if they are in this state now take

the first opportunity of sowing more. Carrots sown about this time or early in August gain a useful size before winter, and wherever there is a deficiency from any cause a sowing should be made. As spring crops are maturing so rapidly now there is no scarcity of ground for Carrots or any other crop.

**AUTUMN-SOWN ONIONS.**—These are one of our finest crops this season. They have neither been watered nor fed, but the heat suited them capitally, and when examining the bulbs the other day they were so fine that we were induced to consult our book as to the time they were sown, and the date was "August 23th, 1886." The large bulbs must be watched. As long as it keeps dry they are not liable to go wrong, but in rainy weather the large ones are very apt to bulge out on one side at the bottom or divide into two at the top, and this spoils their appearance for exhibition and some other purposes. To avoid this the finest should be drawn up and taken under cover, where it is quite dry. This will prevent their splitting, and it is better to have them a little less in size and perfect than large and going to pieces. The very thick-necked ones need not be reserved, as they will never become of any special value. Last year we watered one quarter of these Onions; another piece was not watered. The latter were equally as good as the former, and this year we have dispensed with the watering.

**TOMATOES.**—It is a grand season for Tomatoes. Plants in the open air are not making too much wood. They are very short-jointed, and many fruits are formed; indeed, some of the early ones are well advanced, and will be ripe early in August. Do not allow the plants to suffer from insufficient water. As soon as plenty of fruit is formed give abundance of liquid manure, but do not use this before the fruits appear, as it has a tendency to make them form much wood, and this is against their fruiting heavily. The liquid will induce them to form side shoots, and these must be pinched off frequently. The best crop we have at the present time is in a cool pit. We are happy in our selection of a variety. The fruits are smooth, large, and abundant; and as those are only the one sort in the house the crop is very even. Tomato trials are interesting, but they do not pay for market. We know a large house of Tomatoes planted last spring with a great number of sorts, some not worth growing, and the crop throughout is very disappointing. The owner intended marketing fruit by the "hundredweight," but by the "pound" is the only length he has reached. When plants are bearing a heavy crop under glass it is astonishing how few leaves are required to keep the plants going, and thinning the foliage is almost as beneficial as thinning the shoots. This applies to the foliage on the main stem, which is the largest and most shady. Where plants have nearly ceased to bear throw them away and introduce a coming crop of something else.

**LATE PEAS.**—Those sown a fortnight or three weeks ago are above the ground, but care must be taken that they do not receive a check from the drought, and it is a good plan to place a little manure along each side of the row, and earth them up over this. The soil prevents the manure drying, and the manure in its turn keeps the roots of the plants cool and moist.

#### FRUIT FORCING.

**VINES.**—*Earliest House.*—The Vines will now require a dry atmosphere to thoroughly ripen the wood, but it will not be necessary to employ artificial heat. All laterals and late growths must be kept stopped and complete rest afforded by having the border cool and moderately dry. The borders inside may require water, but if they have been mulched it may not be necessary, whilst the outside borders may need covering with dry draw or bracken in order to throw off heavy rains. This is absolutely essential to insure the complete rest so necessary for Vines long subjected to forcing, a too moist condition of the soil tending to late growth; but there should be sufficient moisture to maintain growth in the laterals in order to prevent the premature ripening of the foliage. In most cases it will be sufficient to allow a moderate extension of the laterals, and where the Vines are in an unsatisfactory condition prepare for lifting at an early date, getting fresh loam and clean drainage, so that the work can be done quickly when started. There is no danger of losing a crop; only operate upon a part of the border at once—say the inside border one year and the outside the following. It is desirable to lift the roots and lay them in fresh soil nearer the surface whilst there is foliage on the Vines; therefore work of this character ought not to be delayed in the case of Vines that are to be started early in December, which will need pruning by the middle of September, or in the case of lifted Vines a little later.

*Houses not Regularly Subjected to Early Forcing.*—Vines that are not started early will need, as soon as the crop is off, to be thoroughly cleaned by syringing or the application of an insecticide, and if there is any doubt about the ripeness of the wood or the plumpness of the eyes it will be necessary to keep the house rather close by day, but with sufficient ventilation to cause evaporation and allow the moisture to escape. Give no more water to the border than will prevent the foliage becoming limp. If the weather prove moist employ fire heat in the daytime to maintain a temperature of 70° to 75° with moderate ventilation, and turn the heat off at night to allow the pipes to cool, increasing the ventilation so as to cause a thorough draught, and this will soon cause the wood to harden and the buds to plump, inducing rest, which for Vines that are to be started in December should be complete from the middle to the end of September. When the Vines have the wood ripe ventilate fully day and night.

*Vines in Pots for Early Forcing.*—Those that are to be started in November should now have the wood thoroughly ripe and the buds lump. If not, and they are later this year than usual, keep the house

rather warmer by day, 80° to 85°, closing early so as to raise the temperature to 90° or 95°, and throw the house open at night. Afford water (or liquid manure will help the Vines to plump the buds) in sufficient quantity to prevent the foliage flagging, and the latter cannot have too much light. Keep lateral growths well in check, leaving no more than are absolutely necessary to appropriate any excess of nutriment, and so prevent the principal eyes starting. When sufficiently ripened, as they are when the wood is brown and hard and the buds are prominent, they should be removed to a situation outdoors, standing on slates or boards in front of a south wall or fence, securing the canes to the face of the wall, only giving water to prevent the foliage falling prematurely, and having some waterproof material to throw the rain from the pots. In this position they will have some rest even if the leaves are not actually shed. When the leaves turn yellow—give indications of falling—commence reducing the laterals, and when the leaves are all off prune, the laterals being cut off close, and the canes cut back to the length required, they being placed in any airy, cool, dry place until required for forcing. Keep them dry at the roots, and yet they must not be allowed to become dust dry, placing some dry protective material about the pots to save the roots from frost in case it should gain access to the structure.

*Vines Freed of their Crops.*—Cleanse the foliage by means of the syringe or engine, and if need be apply an insecticide. If there be any mealy bug or scale promptly use petroleum, a wineglassful to 4 gallons of water, in which 8 ozs. of softsoap and an ounce of soda has been dissolved, keeping the mixture thoroughly agitated by stirring briskly with a broom handle whilst being applied to the Vines, which must be done thoroughly, wetting every part. It is best done on a dull calm afternoon, and should be repeated two or three times at intervals of a few days. If there be any plants they must be removed, and if the roots of the Vines are near the surface, cover the border with dry short material to absorb the waste. Keep the laterals fairly in hand, not closely pinched, unless the Vines are very vigorous and are not ripening the wood kindly, when keeping the house rather dry at night, with all the ventilation possible, and somewhat warm and close by day, will tend to the maturity of the wood and buds. In stopping vigorous Vines regard must be had to the principal buds, not stopping so close as to jeopardise the starting into growth through an excess of sap. Such Vines should also be kept without water until the young leaves are a little limp. Vines that, on the other hand, are not strong, having been enfeebled by continued cropping or other cause, should be encouraged to make growth by applying liquid manure to the border; but whatever extraneous foliage is made must not be allowed to interfere in any way with the free access of light and air to the principal leaves, which must be kept healthy, so that they may appropriate some of the extra food, and store it in the buds and adjacent wood. Ventilate freely day and night.

*Grapes Colouring.*—Admit air constantly, enough with a gentle warmth in the pipes to insure a circulation. Whilst ripening many, indeed most Grapes, swell considerably, therefore there must not be any deficiency of moisture in the border. Give, if necessary, a good supply, and in the early part of the day, so that superfluous moisture may be dissipated before night. If the Vines are heavily cropped afford liquid manure, but not strong, and allow them plenty of time, otherwise if there be any hastening of the ripening and a deficiency of nutriment, it is likely the fruit will be defective in colour. A good rest at night in a temperature of 60° to 65°, with air, is a great help to Vines taxed to the utmost by weight of Grapes. A moderate amount of air moisture also is essential to the health of the Vines, sprinkling available surfaces occasionally, and if possible, allow the laterals to extend; but over-taxed Vines rarely can cater for more than the principal leaves and Grapes.

**CUCUMBERS.**—Any frames that are at liberty may yet be planted with Cucumbers upon a bed of fermenting materials, which will give a supply of fruit in September, and continue up to near Christmas if due regard be paid to lining the beds and to protecting the plants by mats over the lights at night after the weather sets in cold. Let plants in frames or houses be thinned at least twice a week, removing exhausted growths to make room for young bearing shoots. Keep the shoots well stopped to one joint beyond the fruit, or at the fruit if the plants are vigorous and showing no signs of exhaustion. Always allow weakly plants more extension, and crop such lightly. Maintain a steady root-action by necessary bottom heat, and due attention in watering two or three times a week. The bottom heat should be 80° to 85°, top heat 70° at night, 75° by day, 80° to 85° with sun, closing early to increase to 90° or 95°. Syringe in the afternoons of hot days, but avoid late syringing, for the foliage should be dry by sunset, and commence ventilating early, it being important that the foliage be dry before the sun acts powerfully upon it. The autumn fruiters should now or soon be planted on hillocks or ridges moderately firm, maintaining a moist and genial atmosphere, and they will grow freely and show fruit in plenty shortly.

#### PLANT HOUSES.

*Stephanotis floribunda.*—Plants that have been trained upon trellises and have ceased flowering may be taken off and thoroughly cleaned. This work can be done in a shady place outside at this season of the year. If the plants are infested with mealy bug they can be readily cleaned when the branches are untied and laid on mats if liberally syringed with petroleum and water. One ounce of the former should be used to each gallon of the latter. The following day examine the plant carefully, and destroy any insects that may have found hiding places out of the reach of the syringe. If the branches are secured to four or five

stakes inserted round the pot and subjected to this treatment two or three times at intervals of a fortnight, the bug may be completely eradicated and the plant kept clean afterwards if grown in a house in which bug does not exist. The branches should be trained under the roof, so as to give the wood every chance of ripening. After the oil has been evaporated expose the plant to the sun and a cooler, drier, atmosphere.

**Gardenias.**—Provide for the earliest plants a slightly drier and cooler atmosphere, so that growth will be brought to a standstill and well ripened; the formation of flower buds will then take place. Those intended for winter and spring flowering should not have the branches pinched after this date, but be encouraged to grow freely for some weeks. Give abundance of water both to the roots and over their foliage through the syringe. Supply with weak stimulants any plants in active growth that have their pots full of roots; or, better still, apply a little artificial manure to the surface of the soil at intervals of a fortnight or three weeks. If bug or scale appear syringe the plants thoroughly where they stand in the frame or house with the solution advised above, lightly shade the plants for a few days from the sun.

**Ixoras.**—Plants that have flowered may be partially pruned, thoroughly cleaned, and started again into growth. If placed in a close moist atmosphere they will soon start and flower profusely in autumn. When pruning, any shoots that failed to flower should be cut back, and the young growing ends inserted singly in 2-inch pots. These, if pinched once or twice after they are rooted, will make grand decorative plants for flowering early next season in 5 and 6-inch pots. These small plants should be grown more largely for decoration, as they are very beautiful in the stove in early summer, and may be used with advantage for the decoration of rooms. For this purpose cuttings may be rooted during this and the following month, but those rooted last must not be pinched, but allowed to grow upright until they produce a truss. These can be flowered in 3 and 4-inch pots, and again in the autumn in 6-inch pots, carrying four or six trusses each, if well pruned after flowering and potted after they have commenced growth.

**Winter-flowering Plants.**—Such plants as Poinsettias, Euphorbias, Plumbagos and others that are well established and growing freely must now have abundance of light and air. A close, moist confined atmosphere will ruin these plants during the latter stages of growth. To give the greatest satisfaction, firm sturdy growth that is certain to be well ripened must be the principal aim in their culture. This can be accomplished by throwing the lights off during the day, and leaving a liberal quantity of air on all night. If gradually hardened to this treatment the plants will bear full exposure. They should, however, be gradually prepared, which will take two or three weeks. Be careful that they do not suffer by an insufficient supply of water at their roots, or their lower leaves will turn yellow and fall—in fact the whole of the foliage will assume a sickly appearance instead of possessing a dark green luxuriant hue. Plants that have filled their pots with roots may be given soot water in a clear state, and a little artificial manure every two or three weeks.

**Pinks.**—These may be either raised from seed or from cuttings, as in the case of Carnations. They require less space than Carnations, and do not so soon exhaust themselves. Mrs. Sinkins and Lady Blanche, another beautiful white sort, we at one time increased largely by cuttings, but since the stock has become quite large enough we merely plant fresh beds in the autumn, with strong pieces obtained by splitting up the old clumps. Carnations, notably the old Clove, may be propagated in the same way. Even long rootless pieces will strike if only they are dibbled in up to the healthy leaves.

## THE BEE-KEEPER.

### PRACTICAL BEE-KEEPING.—No. 16.

Now that the main features of these three systems have been discussed, it is necessary before proceeding for every bee-keeper to ascertain with what accuracy he can estimate the honey capabilities of his district. By inquiry a very good idea may be formed of the time of the honey flow, even if the bee-keeper has no personal knowledge of the locality. To assist those who perhaps hardly know the great staple flowers and plants upon which we must depend for our honey in this country, I will briefly describe what may be called the main sources of supply. The flowers of the garden Mignonette, Borage, Lobelia, and Wallflowers supply some little honey, but except in very favoured places the quantity derived from such plants is so small that it is unnecessary for practical purposes to dilate at all upon what may be considered these ornamental honey plants. In the early months of the year the Snowdrop and Crocus open their petals of varied hue, and invite the eager bee to collect the pollen which they yield so freely;

but by far the most valuable source of supply in the early months of the year are the catkins of the Hazels and Willows, which yield an abundance of pollen, and are eagerly sought by the bees. This Willow bears a yellow flower, upon which the bees are never tired of working. Gorse, again, is a good useful plant, but until the month of April comes it can hardly be said that honey in any appreciable quantity can be collected by even the strongest stocks. In the month of "sunshine and showers" various plants and trees yield an ever-increasing supply of rich honey when the season is mild. At this period the Ribes sanguinea—the Red Flowering Currant—is crowded with eager workers, and by the great booming "humble bees." "From early morn to dewy eve" the happy hum is heard on every side. The Gooseberry, too, yields honey of a greenish hue, very rich in taste and luscious; the early Pears and Plums, and the drooping threads of Currant blossom and the Raspberry yield lasting supplies until the later Pears and Apples lend their aid. Then, again, the shapely Sycamore begins to expand its Grape-like bunches of blossom bedewed with honey of fine quality and flavour, but rather dark in colour. The Sycamore soon gives place to the rich fragrant fields of Bean, which scent the very air with their excess of nectar, and then are seen the first early blooms of Clover—the Alsike and the White—both precious honey plants, and lovely to the eye of all, while the Yellow Weeds raise their ambitious heads above the growing corn. The dying Clover and the last few struggling heads of Ketlock herald in the Limes, which yield a honey of a bright golden hue, and in their turn the Lime bells fade and die, and in their stead the purple Heather clothes the wild barren moorland wastes with rich fragrant blooms. Such are the principal sources of supply in a bee-keeper's paradise, but in very few districts is there such a long-sustained harvest. For practical purposes there may be said to be three several harvests:—

1. The harvest from fruit blossom, Sycamore, Beans, and Ketlock.
2. The Clover harvest.
3. The Heather harvest.

Many districts have two of these harvests, but few have three. When a bee-keeper has within an easy distance of his stocks fruit orchards, Sycamore, Beans, Yellow Weed, and Clover, he has all that can be expected; and if there is Heather also in the vicinity he is "thrice blessed," and ought to be able to produce honey at a very small cost and therefore at a large profit. Some bee-keepers may not be aware that Yellow Weed, Ketlock, Skellock, Ranches, and Wild Mustard are all one plant. It is well to always remember these various names, because in one county the word is called Ketlock and in the next Yellow Weed, and the bee-keeper may therefore be considerably puzzled by an old plant dressed in a new name. Where there is no Clover harvest great yields can hardly be expected unless there is purple-clad moorland within two miles of the apiary. Of two districts, the one that has fields of Clover in the vicinity is far to be preferred—other things being equal—to one where there is much fruit blossom but little or no Clover. Alsike Clover is being more used by the farmer every year; it is fast superseding the Red, which I believe is absolutely useless to the common bees. Every acre sown with Alsike instead of Red Clover means an extra acre of honey supply.

In ascertaining, then, upon what plants and trees he has to depend, the bee-keeper need only to notice the number of orchard trees in his neighbourhood, to look round and see if the compact round heads of the Sycamore give promise of blossom in due season; to ask the labourer whether White Clover abounds in the fields



and by the roadside, and whether the delicate Alsike has usurped the place of the Red in the meadows destined for the scythe. To look again if the tall cool Limes are to be seen bending their heads gracefully before the breeze, and then it will surely not require much consideration to discover whether Heather is near enough and in sufficient quantity to afford the third harvest. These points must all be carefully considered immediately upon deciding to keep a few stocks of bees, because upon a proper appreciation of the time and value of the harvest the system of management must to a very great extent depend. A word may be said for the Brassica tribe, which are all useful honey and pollen-producing plants, at a time when their supplies are useful; but it is neither necessary nor useful to describe the countless other plants which yield honey in greater or less quantity throughout the spring and summer months, because the quantity under cultivation or growing in a wild state is so small as to rank merely as an assistance, and not as a supply upon which dependance can be placed for yielding a large surplus even in the best of good seasons.

Mr. Pettigrew used to say that it was believed in his day that "a 20-acre field of grass well sprinkled with White Clover yielded every fine day 100 lbs. of honey; and that 20 acres of Heather yielded 200 lbs. of honey each day." This is, I believe, by no means an over-estimate; in fact it has always appeared to me probable that in fine warm weather such an acreage of Clover would yield at least half as much again. This is, however, simply a matter of conjecture on my part. In some seasons the honey is almost ruined by the black aphides' fluid which bees sometimes persist in collecting even when flower honey abounds. A very little of this dark compound will spoil the finest honey and make it unfit for market. Beekeepers can do nothing to prevent this evil, and it is therefore doubly hard to see our bees collecting honeydew while we are powerless to direct their labours to a more legitimate supply. Oaks and Sycamore and Limes are often covered with it; the whole tree sometimes resounding with the glad hum of busy bees wasting their energy and precious time in collecting honey useless to man and unwholesome for winter consumption in the hive. In conclusion it may be said that unless there is a good supply of honey-yielding plants within two miles of the apiary not all the Clover and Heather in the kingdom will be of much use to the bees if at a greater distance. Occasionally bees do travel even longer distances than two miles, but for practical purposes I believe with many other beekeepers that any source of supply more than two miles distant from the bees is practically worthless.—FELIX.

#### CYPRIAN BEES—CROWDING BEES.

I READ with much interest the remarks of "A Lanarkshire Beekeeper," and hope he will continue describing his experience. But when we read of the extraordinary result of the Cyprian's it makes us wish we could have them. There are, no doubt, many working men that would like to have what others have too much of. I hope the day will come when I shall be able to add them to my apiary. I was in hopes someone would have advertised the best hive in creation, but have been disappointed. I should like information on taking bars from hives after the honey season, and crowding the bees on as few as possible for the winter, then adding more in spring. There is a small bee-keeper a little distance from here that practises the above, but he cannot give any reason for so doing. Is it a good plan, or is it better to let them alone?—R. C., Kent.

#### TRADE CATALOGUES RECEIVED.

Chr. Lorenz, Erfurt, Germany.—*List of Bulbs, Flower, and Vegetable Seeds (illustrated).*

James Dickson & Sons, 108, Eastgate, Chester.—*Catalogues of Bulbs, Pæonies, Narcissi, and Strawberries.*

W. Cutbush & Sons, Highgate.—*Catalogue of Bulbs.*



## TO CORRESPONDENTS

All correspondence should be directed either to "THE EDITOR" or to "THE PUBLISHER." Letters addressed to Dr. Hogg or members of the staff often remain unopened unavoidably. We request that no one will write privately to any of our correspondents, as doing so subjects them to unjustifiable trouble and expense.

Correspondents should not mix up on the same sheet questions relating to Gardening and those on Bee subjects, and should never send more than two or three questions at once. All articles intended for insertion should be written on one side of the paper only. We cannot reply to questions through the post, and we do not undertake to return rejected communications.

**LATE INQUIRIES.**—It is necessary to again remind correspondents that letters arriving on WEDNESDAY MORNING cannot be answered in the "next issue," which is then far advanced for press.

**Chrysanthemums (C. H. R.)**—You may take two shoots from the break, and after the buds are safe and swelling freely remove one of them if you desire to produce the finest blooms the plants are capable of developing. If you only have one shoot an accident might occur in setting the bud, and it is advisable to provide for contingencies.

**Rose Sporting (Mrs. Townshend Mainwaring)**—The stem you send bearing a yellow and a pink bloom affords clear evidence of sporting. It is not a common occurrence, though is occasionally seen, and we think distinct varieties have been established by propagating from sports by budding or grafting. Most of the new incurved Chrysanthemums are produced in the same accidental way.

**Rose Buds Starting (C. F.)**—It is not unusual for Rose buds that are inserted early to start into growth almost immediately, and when they grow thus early in the season there is a fair chance of the wood maturing before winter. Cut back the stems on which the buds are inserted with the view of encouraging the Roses to grow and ripen their wood. We have often known the buds to grow and flower the same year. It is when the buds spring in September and October that they are so liable to be destroyed in the winter.

**Pea (E. B.)**—It is next to impossible to form a clear and definite opinion as to the distinctness of a variety from an examination of half a dozen pods. We can only say that those before us resemble in size, shape, and fulness the variety sold as House's Perfect Marrow, the new Pea Sir F. Milbank (Sharpe's) being of the same character. They are productive and excellent of the Ne Plus Ultra type, and to this fine old Pea the pods before us are not very dissimilar. We have no doubt it is a good Pea and worth growing, but doubt if it is sufficiently distinct to possess any special commercial value.

**Large Onions (O. E. S.)**—It does not follow, as you seem to think, that if you sow your winter Onions much sooner than usual that they will necessarily be larger; on the contrary, they may be smaller, as if sown too early they are apt to produce flower stems in the spring, and in that case the bulbs seldom attain a good size or shape. As a rule the end of the first week in August is early enough, though localities and seasons exert an influence on the plants. We have seen no finer Onions this year than those exhibited by Mr. C. J. Waite in his prize collections of vegetables, and we believe they were grown from seed sown about August 10th. Deep, rich soil, with plenty of water and surface mulchings in hot weather, induce free, unchecked growth that results in large handsome bulbs.

**Grapes Mildewed (Constant Reader)**—The cause of mildew is variably attributed, but it mostly arises from a variable atmosphere, periods when the air is close and moist, followed by a sudden change to cold and dry. Happily it is easily destroyed, the parts infested being dusted with sulphur, which, taken in hand when the pest first appears and persisted in, is an effectual remedy. Your case, however, is a bad one, and we should advise you employing sulphide of potassium, following the instructions of the vendors. Messrs. Philip Harris & Co., Bull Ring, Birmingham, prepare it specially for horticultural purposes, and have advertised it in this Journal. You ought to have applied for a remedy sooner, for though you may destroy the mildew on the Grapes you cannot now expect well-finished fruit.

**Watercress (Water)**—This can be grown in the midlands and northern counties with the ordinary water of the district. We have seen it growing luxuriantly on a small scale in Staffordshire, Notts, Lincolnshire, Durham, and Northumberland, and it would grow equally well if cultivated on a large scale in those districts. If you wish to enter into Watercress culture for commercial purposes we strongly advise you to inspect some beds, and you will gain more information in half an hour than you could gather from columns of print. It is impossible to give an estimate of cost, that obviously depending on the extent of culture and other circumstances. You may plant in the autumn or very early in spring. Near Hackbridge station on the L.B. & S.C. Railway you may see Watercress growing in beds supplied with Croydon sewage, and others in pure water. You are not very far from London, and Hackbridge is only about half an hour's journey from Victoria.

**Roses not Opening (Kittie)**—The buds you have sent are small, hard,

and, as you say, "stained." The wood is also weak, and the leaves thin and pale in colour. Some of the shoots appear as if they had been cut from plants that were not closely pruned in the winter or early spring, and the roots have not been able to gather and supply adequate support for the development of the blooms during the exhausting weather that has so long prevailed. The moisture has been extracted from the buds and leaves in excess of the supply from the roots, hence the withering and staining or decay of the petals. Heavy applications of liquid manure, with thick mulchings, would have done good, for the plants are evidently in an enfeebled state, and we suspect that some of them at least would have been better if closer pruning had been resorted to. Pick off the hard, stubborn, discoloured buds, and thin out the others freely, then the flowers may possibly expand if you give thorough drenchings of liquid manure to the roots.

**Old Strawberry Ground (F. J.).**—Since Strawberries have been grown on the land for several years it is no doubt to a great extent impoverished, hence their deterioration. We should trench them in and not crop the land this year. Next year by preparing sets of Early Ashleaf or Myatt's Prolific Potatoes and planting as soon as the weather permits, spreading a handful of kainite and superphosphate of lime along every six or seven yards of drill with the sets, you ought to have a profitable crop of Potatoes that would be cleared in time for planting Strawberries afterwards, stout well-rooted runners being requisite for the purpose. The Potatoes, when above ground, may be further dressed with from one to two ounces of sulphate of ammonia per square yard applied on a showery day before hoeing between the rows. If you have any other garden refuse, decayed leaves, or wood ashes, trench every particle into the land with the old Strawberry plants, and lime applied at the same time would also do good. After a course of treatment of the nature indicated, we think good Strawberries may again be grown, mulching well with good manure. If you can saturate the ground with strong liquid manure or undiluted sewage its fertility would be greatly increased.

**Salting Walks (J. Sunley).**—It is quite a mistake to suppose that salt can be more economically and effectively applied to walks in the form of a solution for destroying weeds than spread on them in a dry state. We have tried both methods, and if you spread some salt on a portion of a walk in dry weather, so that it rests on the surface for a few days, and use the same quantity dissolved in water and distributed over an equal extent of surface, you will find that though the weeds may be destroyed in both cases, others will spring up much sooner on the part to which the salt was applied in solution than where spread on in a dry state. It is much more effective applied in hot dry weather than on showery days. The common agricultural salt answers quite well. It is not usual to use rock salt for the purpose in question, though if ground or crushed into small particles, which would increase the cost, it would no doubt answer. We have seen many miles of walks salted, and have no hesitation in saying where one ton of rock salt is used a hundred tons of the common agricultural salt are applied for the destruction of weeds. If there are Dandelions, Docks, or similarly deep-rooting weeds in the walks, a few drops of sulphuric acid should be applied to the heart of each plant. Dry salting will destroy grass and all surface-rooting weeds, but if the salt is dissolved much of it passes from the weeds quickly into the subsoil, and they escape, so to say, its full strength. The longer the salt rests on the surface the more powerful is its action on weeds of the nature indicated.

**Poor Soil (F. W., Devizes).**—The sample of soil is poor and rather light. We should not rough dig and manure such soil in the autumn, but dig in abundance of short rich manure in the spring, cow manure preferably, a few weeks only before sowing and planting; and in summer we should mulch between the crops heavily with good manure if possible; failing that, with short grass, spent hops, or anything that would lie closely on the soil. Of the samples of crushed bone you have sent the coarser would be the more endurable in its effects, the latter more immediate in action but not so lasting. For quick-growing crops to be soon cleared off the ground the fine dust would possibly give you the most satisfaction; for Strawberries and permanent crops the other is more suitable. Dig the ground as deeply as possible without bringing up the green sand. We doubt if gas lime would be of any material benefit; but bones would do good, especially if the ground can be kept moist by thick mulchings in early summer. Use all the short manure possible, cow manure being much better than that from horse stables for such light thin land. A heavy dressing of clay would be of great benefit, but perhaps you have none to apply; and sowing salt at the rate of 4 cwt. per acre, or nearly 2 ozs. to the square yard, in March, would possibly be advantageous. Some of the bone dust mixed with the soil would improve it considerably for casing Mushroom beds. We have seen good crops produced when soil has been used quite as light as yours, indeed lighter. The great point is to keep such soil moist by sufficiently thick coverings for arresting evaporation. You had better use all your spent hops in the form of mulching, not mixing them with manure for any purpose.

**Names of Fruits.**—The names and addresses of senders of fruit to be named must in all cases be enclosed with the specimens, whether letters referring to the fruit are sent by post or not. The names are not necessarily required for publication, initials sufficing for that. Only six specimens can be named at once, and beyond that number cannot be preserved. (J. S. A.).—The Strawberries were crushed into pulp when they reached this office; they evidently were not packed firmly enough. (C. B. B.).—We know of no Peach so nearly combining the characters you name as Lord Palmerston, and this the specimen you have sent somewhat resembles; but there are slight variations in the shape and colour of Peaches gathered from the same tree.

**Names of Plants.**—We only undertake to name species of plants, not varieties that have originated from seed and termed florists' flowers. Flowering specimens are necessary of flowering plants, and Fern fronds should bear spores. Specimens should arrive in a fresh state in firm boxes. Slightly damp moss or soft green leaves form the best packing, dry cotton wool the worst. Not more than six specimens can be named at once. (G. L. C.).—Agrostemma coronaria, the Rose Campion. (J. S., Aberdeen).—The flowers are all good, but No. 3 is more like the ordinary Cattlea Gaskelliana. No. 2 is much the best in colour, but is like a medium-size, highly coloured C. Mossiae. No. 1 is a pale form, rather delicate and pretty.

(R. W.).—The Lily is *Lilium testaceum*, and is by no means rare, and it is one of the best for town gardens. It is frequently shown in London by the nurserymen who make hardy flowers a speciality, and has an excellent effect in the groups with bright coloured Lilies like *L. pomponium*, and dark ones like *L. martagon dalmaticum*. As you remark, its distinct colour and fragrance render it attractive, but the colour is rather too powerful for some persons. (J. F. C., Leeds).—The plant is *Sisymbrium millefolium*, and has been recommended for table decoration. It is graceful, but soon loses its leaves in a hot room. \* \* \* We have received boxes of flowers, but no letters referring to them, therefore it were obviously futile to publish the names of specimens if they were sent for that purpose.

COVENT GARDEN MARKET.—JULY 27TH.

HEAVY supplies to hand, with trade brisk at lower prices.

FRUIT.

	s. d.	s. d.		s. d.	s. d.
Apples, ½ sieve .. ..	0 0	0 0	Oranges, per 100 .. ..	6 0	to 12 0
Nova Scotia and			Peaches, dozen .. ..	4 0	10 0
Canada barrel .. ..	0 0	0 0	Pears, dozen .. ..	0 0	0 0
Cherries, ½ sieve .. ..	3 0	6 0	Pine Apples, English,		
Cobs, 100 lbs. .. ..	0 0	0 0	per lb. .. ..	1 6	0 0
Figs, dozen .. ..	3 0	4 0	Plums, ½ sieve .. ..	0 0	0 0
Grapes, per lb. .. ..	1 6	2 6	St. Michael Pines, each	3 0	5 0
Lemons, case .. ..	10 0	15 0	Strawberries, per lb. ..	0 3	0 10
Melon, each .. ..	2 0	3 0			

VEGETABLES.

	s. d.	s. d.		s. d.	s. d.
Artichokes, dozen .. ..	1 0	to 2 0	Lettuce, dozen .. ..	0 9	to 0 0
Asparagus, bundle .. ..	0 0	0 0	Mushrooms, punnet ..	0 6	1 0
Beans, Kidney, per lb. ..	1 3	0 0	Mustard and Cress, punt.	0 2	0 6
Beet, Red, dozen .. ..	1 0	2 0	Onions, bunch .. ..	0 3	0 6
Broccoli, bundle .. ..	0 0	0 0	Parsley, dozen bunches	2 0	3 0
Brussels Sprouts, ½ sieve	0 0	0 0	Parsnips, dozen .. ..	1 0	0 0
Cabbage, dozen .. ..	1 6	0 0	Potatoes, per cwt. .. ..	4 0	5 0
Capiscum, per 100 .. ..	1 6	2 0	Kidney, per cwt. ..	4 0	0 0
Carrots, bunch .. ..	0 4	0 0	Rhubarb, bundle .. ..	0 2	0 0
Cauliflowers, dozen .. ..	3 0	4 0	Salsafy, bundle .. ..	1 0	1 6
Celery, bundle .. ..	1 6	2 0	Scorzoneria, bundle ..	1 6	0 0
Coleworts, doz. bunches	2 0	4 0	Seakale, basket .. ..	0 0	0 0
Cucumbers, each .. ..	0 4	0 6	Shallots, per lb. .. ..	0 3	0 0
Endive, dozen .. ..	1 0	2 0	Spinach, bushel .. ..	3 0	4 0
Herbs, bunch .. ..	0 2	0 0	Tomatoes, per lb. .. ..	0 4	0 6
Leeks, bunch .. ..	0 3	0 4	Turnips, bunch .. ..	0 4	0 6

PLANTS IN POTS.

	s. d.	s. d.		s. d.	s. d.
Aralia Sieboldi, dozen ..	6 0	to 12 0	Fuchsia, dozen .. ..	3 0	to 9 0
Arbor vitae (golden) dozen	6 0	9 0	Geranium (Ivy), dozen ..	4 0	6 0
(common), dozen .. ..	0 0	0 0	Tricolor, dozen .. ..	3 0	6 0
Azalea, dozen .. ..	0 0	0 0	Hydrangea, dozen .. ..	9 0	12 0
Begonia, dozen .. ..	4 0	9 0	Lilies Valley, dozen .. ..	0 0	0 0
Calceolaria, dozen .. ..	3 6	8 0	Lilium longiflorum, doz.	12 0	18 0
Cineraria, dozen .. ..	0 0	0 0	longiflorum, doz.	18 0	30 0
Creeping Jenny, dozen ..	3 0	4 0	Lobelia, dozen .. ..	3 0	5 0
Dracena terminalis, doz.	30 0	60 0	Marguerite Daisy, dozen	6 0	12 0
viridis, dozen .. ..	12 0	24 0	Mignonette, dozen .. ..	3 0	6 0
Erica, various, dozen ..	12 0	24 0	Musk, dozen .. ..	2 0	4 0
Enonymus, in var., dozen	6 0	18 0	Myrtles, dozen .. ..	6 0	12 0
Evergreens, in var., dozen	6 0	24 0	Palms, in var., each ..	2 6	21 0
Ferns, in variety, dozen	4 0	18 0	Pelargoniums, dozen ..	6 0	15 0
Ficus elastica, each ..	1 6	7 0	scarlet, doz. .. ..	3 0	9 0
Foliage Plants, var., each	2 0	10 0	Spiraea, dozen .. ..	6 0	12 0

CUT FLOWERS.

	s. d.	s. d.		s. d.	s. d.
Abutilons, 12 bunches ..	2 0	to 4 0	Marguerites, 12 bunches	2 0	to 6 0
Anemones, 12 bunches ..	0 0	0 0	Mignonette, 12 bunches	2 0	4 0
Arum Lilies, 12 blooms ..	3 0	6 0	Myosotis, 12 bunches ..	2 0	3 0
Azalea, 12 sprays .. ..	0 0	0 0	Narciss, 12 bunches ..	0 0	0 0
Binebells, 12 bunches ..	0 0	0 0	White, English, bch.	0 0	0 0
Bouvardias, bunch .. ..	0 6	1 0	Pansies, 12 bunches ..	2 0	4 0
Camellias, blooms .. ..	0 0	0 0	Peas, Sweet, 12 bunches	3 0	6 0
Carnations, 12 blooms ..	1 0	2 0	Pelargoniums, 12 trusses	0 9	1 0
12 bunches .. ..	4 0	6 0	scarlet, 12 trusses	0 4	0 6
Cornflower, 12 bunches ..	1 6	3 0	Pinks, White, 12 bunches	1 0	4 0
Daisies, 12 bunches .. ..	2 0	4 0	various, 12 bunch	2 0	4 0
Encharis, dozen .. ..	4 0	6 0	Poony, 12 bunches .. ..	0 0	0 0
Gardenias, 12 blooms ..	1 6	3 0	Pointsettia, 12 blooms ..	0 0	0 0
Hyacinths, Roman, 12			Primula (single), bunch	0 0	0 0
sprays .. ..	0 0	0 0	(double), bunch ..	0 9	1 0
Iris, 12 bunches .. ..	2 0	9 0	Polyanthus, 12 bunches ..	0 0	0 0
Lspageria, white, 12			Ranunculus, 12 bunches	0 0	0 0
blooms .. ..	0 0	0 0	Roses, 12 bunches .. ..	2 0	6 0
Lilium longiflorum, 12			(Indoor), dozen .. ..	0 9	1 0
blooms .. ..	3 0	6 0	Tea, dozen .. ..	1 6	3 0
Lilac (white), French,			red dozen .. ..	0 0	0 0
bunch .. ..	0 0	0 0	de Moiss. 12 bunches	0 0	0 0
Lilies, White, 12 bunches	12 0	24 0	Stephanotis, 12 sprays ..	1 6	3 0
Orange, 12 bunches	9 0	12 0	Tropaeolum, 12 bunches	1 0	2 0
Lily of Valley, 12 sprays	0 0	0 0	Tuberose, 12 blooms ..	0 6	1 0
" 12 bunches	0 0	0 0	Tulips, dozen blooms ..	0 0	0 0



CROPPING A FARM.

WILL it answer? is the very natural question asked by a prudent man when he considers and compares one

crop with another, in order to select the best of them both for the land of his farm and the markets open to him for the disposal of his farm produce. The term "answer" is a broad and comprehensive one, bearing as it does not only upon the full development of a crop, but the subsequent profitable use or sale of it. The downward tendency of prices for almost all farm produce often upsets the most careful calculations, the most prudent schemes, yet without a purpose and plan we cannot work with any degree of certainty, and therefore we are bound to make such arrangements as appear best calculated to lead to success.

Local influences must always affect our plans, unless indeed we can obtain a market in some great mercantile centre; but even there we are in competition with the markets of the whole world, for that is undoubtedly what free trade has brought us to. Well, complaints are useless, for are we not the head and centre of a vast empire? Protection may be asked for, but protection against what? Depend upon it, if a scheme of federation is to be carried out there must be no exclusion of colonial enterprise by the mother country. Instead of crying out for impossible measures of State aid, far better would it be to set ourselves earnestly to try and manage our farms so as to make them more profitable. It is ridiculous to suppose that the Government is not intimately acquainted with the difficulties with which the efforts of farmers are now beset. We know as a positive fact that in common with other landlords, the leader of the House of Commons has farms in hand which he would let if he could, and we could point to more than one noble member of the House of Lords whose income is so much reduced that he cannot afford to live upon his property, but has either let his country house or closed it.

Turning now to farmers and their work, it is most important at the outset that they should hire a farm well within the scope of their means. Never was the difference between good and bad farming more apparent than it is now. No doubt the drought has been very trying for spring corn, but we have recently seen Barley fields with only a hedge between them so different in appearance that it seemed hardly possible that the soil was alike on both sides of the hedge. It was naturally of the same staple, yet how different had it become under cultivation! On the one hand the Barley was positively rampant with luxuriance of growth, and fine long ears of corn crowned every stem, the drought notwithstanding. Barley and nothing else was to be seen in the field. On the other hand the Barley, stunted in growth and so parched that its leaves were turning yellow before the meagre little ears had fully appeared, would not afford half a crop, and wild Oats had sprung up so thickly among it that it could only eventually be used as grinding corn. The difference in the crops of the two fields is precisely that of good and bad farming. The good Barley will probably realise from 36s. to 40s. a quarter; the other will be practically unsaleable.

In some soils Barley has a strong tendency to degenerate into a coarse inferior grain such as the buyers of malting Barley do not care for, and as the price given for grinding Barley is invariably less than for malting Barley, the area of land devoted to its culture should be restricted to home requirements. Not lightly would we turn from this part of our subject, for among all farm crops there is none which answers better than a large one of Barley-fed pigs. To grow Barley specially for this purpose is undoubtedly good practice, but there must be careful intelligent management of the pigs, and then the con-

version of Barley into pork will prove a sound and profitable investment.

Pigs have always had a place among farming stock. In the good days of high prices for corn their use was to consume tail corn, and it was never thought desirable to assign them a prominent or leading place in farming economy. But with such low prices for corn that it is by no means an easy matter to cultivate it profitably, it is surely worth while seeing if we cannot turn some of it to account by striving for a share of that pork trade which has for some time put such large sums of money into the pockets of foreign producers and importers. Swine hold a lowly position in the agricultural mind in comparison with that of cattle, but we prefer a clear profit upon swine-rearing to the loss which now attends the fattening of bullocks for market.

(To be continued.)

WORK ON THE HOME FARM.

In such a hot dry season it would appear to be an easy matter to keep down weeds. We certainly have not found it so. In spring and early summer Couch Grass had special attention; since then Charlock, Thistles, and Docks have afforded much work, so much in point of fact that we cannot claim to have done all we wished. It is costly work this endeavour to eradicate weeds from a farm, yet it must be done, and very much of it may be done well and comparatively cheaply by the timely use of corn and root horse hoes. Caution is necessary in using harrows among spring corn to destroy Charlock, for if the weather continues hot and dry afterwards the Barley plant is liable to suffer. The harrows so used ought therefore to be very light, so that the Barley may not be loosened in the soil. This hint is given, by the way, to be turned to account another season. A quiet walk alone through one of our off farms enabled us to learn more of the actual condition of the land than if the bailiff had been with us. We first went across a field of Barley which should have been exceptionally clean, for it was under White Mustard last year, and was ploughed two or three times. To our surprise we found it badly infested with Thistles, as was also an adjoining field of Barley. Now this second field had a fine crop of Mangold upon it last year, and was kept clean; we could therefore only suppose the Thistle seed was sown with the Barley. It might of course be blown upon the land from the hedgerows, but we think not, for the bailiff is a careful man, and we found men employed in cutting down weeds alongside the hedgerows to prevent seeding. In a field of Winter Beans Charlock had come so freely among the Beans that hand-pulling of the weeds was being done. This is a costly process, but a thorough one, which we hope will eradicate Charlock from that field. We found a few patches of Dodder among some Red Clover; each patch of this destructive parasite will be carefully collected and burnt. Winter Oats after Wheat, and Barley after Barley, are good crops on this farm; both fields had a full dressing of home-mixed chemical manures early in spring. It is by the regular annual application of manure that we are able to avoid rotation cropping; we have only to keep the land well supplied with the necessary elements of fertility and we can continue sowing Wheat or other corn upon the same land as long as we please.

METEOROLOGICAL OBSERVATIONS.

CAMDEN SQUARE, LONDON.

Lat. 51° 32' 40" N.; Long. 0° 8' 0" W.; Altitude, 111 feet.

DATE.	9 A.M.					IN THE DAY.				Rain
	Baromet. at sea level.	Hygrometer.		Direction of Wind.	Temp. of soil at 1 foot.	Shade Temperature.		Radiation Temperature.		
		Dry.	Wet.			Max.	Min.	In sun.	On grass.	
1887.										
July.										
Sunday .....	30.251	62.7	55.0	N.	64.8	72.4	51.5	122.7	50.2	0.063
Monday .....	30.257	59.1	51.9	N.	63.3	73.2	45.6	117.8	41.3	—
Tuesday .....	30.262	65.6	56.0	N.E.	63.4	73.4	43.8	124.2	46.7	—
Wednesday ..	30.295	70.4	60.8	N.E.	64.2	82.3	51.9	127.9	50.8	—
Thursday .....	30.269	65.4	53.2	E.	65.2	73.3	55.2	121.5	53.1	—
Friday .....	30.094	61.8	58.6	E.	65.7	81.7	50.1	121.7	45.2	—
Saturday .....	31.172	68.8	59.1	N.W.	65.5	81.3	56.7	126.3	52.0	—
	30.229	61.8	57.2		64.6	73.2	51.1	123.2	43.8	0.063

REMARKS.

- 17th.—Fine morning, then cloudy; heavy shower about 3.30 P.M.; evening fine and cool.
- 18th.—Bright and pleasant.
- 19th.—Fine morning; cloudy at times after.
- 20th.—Fine, bright, and hot.
- 21st.—Bright and fine.
- 22nd.—Hot, and very hazy; close and oppressive.
- 23rd.—Bright and hot.

A fine pleasant week, with only one shower of rain. Temperature nearly 3° lower than that of the preceding week (the nights being much colder), but still above the average.—G. J. SYMONS





## COMING EVENTS

4	TH	
5	F	
6	S	
7	SUN	9TH SUNDAY AFTER TRINITY.
8	M	
9	TU	
10	W	Royal Horticultural Society—Fruit and Floral Committees at 11 A.M.

## PACKING FLOWERS.

**A**MONGST the many duties of a gardener that of packing flowers to travel by rail or through the post is by no means the least important; in fact, in some gardening establishments it is of even greater consideration than packing fruit. The majority of ladies and gentlemen who can afford to "keep up" their gardens, either leave home for the London season, the seaside, or elsewhere for long or short periods, according to circumstances. Flowers then have to be packed two or three times weekly, and in many establishments it is a constant practice when at home to send flowers away to friends. Many young gardeners undertaking these duties for the first time, as well as many amateur readers, may be glad to know how they can accomplish the task satisfactorily.

The first matter to be considered is the train by which they shall travel, or the post by which they shall be despatched, so that they will arrive at the appointed time with as little delay in transit as possible. The shorter the time they are on the journey the fresher the flowers when they are unpacked. A day, or even a few hours, is a great consideration during hot dry weather, and would alter to a large extent all other arrangements, both as regards the condition of the blooms and the time they are cut. It must be remembered that flowers expand even when packed in boxes or other contrivances just in proportion as the weather is hot, or the reverse. In this, as in many other matters connected with gardening, it is difficult to lay down hard-and-fast rules, as many diverse circumstances have to be considered. I shall, therefore, fix a time for the flowers to be sent from the garden, and how to arrange matters for that purpose, and thus leave each individual to judge for himself.

Let us suppose, then, that the flowers have to be packed in time to leave the garden by 6 P.M., so that they will arrive at their destination early the following day. It is always wise, if possible, to arrange matters so that the flowers are travelling at night instead of the day. Some years ago I found the boxes despatched from these gardens by a mid-day train arrived the following day. Complaints were numerous, but after matters were arranged for the garden boxes to travel at night and be delivered early in the morning, we never had a single complaint during a period of nearly ten years.

Perhaps the most difficult matter to be taken into consideration is the time to cut the flowers so that they will arrive in the best condition the following day. At first it might be naturally thought that the nearer the packing time the better and the more certain the flowers would be to last. This is a great mistake, and one that

is too generally practised, as I have proved and hope to clearly demonstrate for the benefit of others. In nearly every instance they should be cut three or four hours before they are packed. Such flowers as double and semi-double Pelargoniums can be cut just before packing, but not so with Roses and many other flowers. All flowers that expand rapidly (take Roses as an example) should be gathered in the morning while the dew is upon them, for if exposed to the sun during the day hundreds that would be suitable for packing would be too fully developed. Roses should be gathered in a bud state, their leaves and stems immersed in water, and then stood in a cool shed; others not sufficiently developed may be gathered at dinner time and treated similarly. It is surprising how well they travel and how fresh they arrive when packed in a suitable manner after their stems have been in water for a few hours. If *Adiantum cuneatum* is cut from the plants and placed at once into the packing boxes—however well it may be grown for the purpose—it will wither directly it is removed; but this will not be its condition if steeped for a few hours in a bucket of water prior to packing. It should be subjected to the same treatment, if only for a short time, directly it arrives, and it is surprising how long it will retain a beautiful fresh appearance.

Hampers or baskets are objectionable in which to pack flowers for travelling a long distance, for the contents are too much exposed to the drying influences of the atmosphere. I have used them, however, with marked success by placing a layer of Rhubarb leaves, Spinach, or other suitable material of a similar nature at the base, then lining the sides in the same way as the process of filling proceeds. The leaves used should be well damped or dipped in water, a few damp leaves being laid between the layers of flowers and also over them. This method is good for short journeys, and may be practised for longer ones if no better packing cases exist for the purpose. The best system of all is to pack the flowers in tin boxes, made to fit inside a larger box; the lid can either be at the top or at the front. Tin boxes are always cool and retain any moisture that falls from the leaves and stems, which would be absorbed if wood is used. The carriage, however, must be considered, and for economy in this matter tin is objectionable, for it is considerably heavier than light boxes made of wood. Although we had suitable tins for this and other purposes they were only used for a short period of the year, when fruit as well as flowers were sent in the same large box. Light boxes were made 4 inches deep; the length and width can be arranged to suit the box in which they have to be packed, but the one must fit closely on the top of the other. Lids therefore are not needed except in the case of the top box, which should be provided with one, especially if the lid of the box in which they are packed opens at the top. This allows of a strip of wood or anything else being placed between the two lids, so that no movement of the boxes can take place. When the boxes are slipped in from the front no lid is needed as long as they are made to fit exactly, a few leaves when hampers are used over the flowers of the top box being ample.

In packing the flowers the use of cotton wool, moss, or Spinach leaves cannot be too strongly condemned; these materials only take up room and waste valuable time in preparation and packing. Cotton wool is one of the worst materials that can be used, for it extracts the moisture from the flowers, and thus assists in their destruction. It may be suggested that it can be used in a

moist state and laid amongst the stems of the flowers, and that moss or Spinach can be employed in a similar way. In many localities moss cannot be had, and in the case of the other two it is a needless expense. If the flowers are prepared as pointed out there is no need for any packing material about their stems, if laid carefully but closely together and the boxes filled.

Cotton wool or any other material is not needed in the case of Orchids, Camellias, Gloxinias, Allamandas, Dipladenias, Eucharis, Lilies of sorts, and other flowers of a like choice and delicate nature that are easily bruised, and amongst the most difficult to pack to insure their arriving fresh and in good condition. Camellias are best packed in shallow boxes, with only a double sheet of tissue paper over the bottom; they can either be tacked to the bottom of the box with small nails, or, what is more convenient, bore two holes nearly together and tie the stems to the bottom with string or thin wire, the latter is advisable, as it can be more readily fastened by twisting at the bottom. This is supposing they are cut with a portion of wood attached. Place no paper or wool over them, the lid of the box being made secure. If sent to any person not in the habit of receiving them packed in this manner, give directions how to take them out. If cut without wood there is no alternative but to place each flower in a portion of cotton wool. One layer of flowers only in this case should be placed in shallow boxes, and every care must be taken that the box is filled with wool so that no movement can take place. Any of the other flowers named can be packed in the ordinary trays or boxes. A single layer of these flowers only should be arranged together, and if they will not fill the boxes place a layer of flowers of a hardier nature at the base, then the Orchids—say Cattleyas or Gloxinias above them, carefully inserting their stems amongst the flowers beneath. The latter should be laid on their side, and also the spikes of Cattleyas; but if single blooms they may be arranged upright. Spikes of Odontoglossums, Oncidium, and others can be laid flat. Over these arrange a good layer of *Adiantum cuneatum* fronds, placing their stems carefully amongst the other flowers at first until the flowers are well covered, when others can be laid on to fill the box. If the boxes are nearly full of any of the delicate flowers that have been mentioned very few fronds are needed to protect any portion of the flower from contact with the bottom of the box that will be placed above them. It will readily be observed that cotton wool is not needed when this method of packing is properly carried out. A spray-distributor placed in a bottle of clean water should be in every shed where flowers have to be packed. As the boxes are filled a fine spray, like dew, should be blown over the surface of the flowers, and when unpacked they have a beautiful fresh appearance as if they had only just been cut.

Wreaths and crosses, or even buttonhole bouquets, should be packed in shallow boxes according to their size. The latter should be secured to the base, the same as advised for Camellias. For the two former two strings should be fastened to the hoop or whatever forms the base, and then passed through two holes in the bottom of the box, and if tied they cannot move or any harm be done to the flowers whichever side the box is turned. Secure bouquets on the same principle, only two strips of wood should be arranged across the box for them to rest upon, or, better still, a false bottom may be made with a good sized circular hole in the centre, through which the stem can be passed. This is the best arrangement, only it is the most trouble, and the other will answer the purpose

very well. The string or wire by which it is to be secured should be fastened to the formation of the bouquet before the arrangement of the flowers commences, then when made it can be hung up, flowers downwards, until ready to place in the box, or before if occasion requires. This string should be passed through the hole in the handle, and is a good assistance in drawing the handle into its proper position. When lifted out of the box all that is needed is to cut off the string level by the base of the holder. In these arrangements every flower is usually wired, and the Fern as well; therefore it is of the utmost importance to dew both thoroughly as soon as they are made, and again if thought necessary, when the lid of the box is nailed down. Recently we inspected about forty wreaths, and the Fern in some of them was completely withered when they arrived, but one subjected to the treatment described was as fresh twenty-four hours after as when placed in the box.

Many boxes suitable for sending through the post have been introduced during recent years, but none that I have seen is exactly what is required. Some of them are admirable for a variety of purposes, but not suitable to pack flowers in that have been prepared according to the method I have pointed out. If the flowers are placed in cardboard boxes perfectly dry or nearly so, the boxes absorb too much water from the flowers. Light tin boxes are much the best, then the flowers can be placed in them thoroughly moist and dewed when full. They will arrive fresh without the least fear of injury to other parcels they come in contact with while in the hands of the postal authorities.

With care, judgment, and intelligence flowers can be packed to arrive after a long journey perfectly fresh during the hottest months of the year.—WM. BARDNEY.

### RIPENING GRAPES.

A FRIEND writes: "There will be plenty of red Hamburgs this year," and as far as my experience goes I should say he is not far out in his calculations. Fortunately, it is possible for Hamburg Grapes to be both red and good to eat. Redness in this case would not be altogether the result either of overcropping or shanking. It is brought about either by poverty at the roots, a bad attack of red spider, or too rapid ripening. Borders that have been formed nobody knows how long, which do not get renewed in any way, and receive little beside clear water, are not capable of supporting a heavy crop of fruit, and judicious cropping and slow ripening are the only means in such cases of securing a fair quantity of both well-coloured yet good-flavoured bunches. Although red Grapes may be nearly or quite as good in quality as those much better "finished," they never attract any admiration from those who have them on their tables, and they are not nearly so valuable for marketing purposes. We sometimes hear it said that the red or reddish Grapes, including Hamburgs, Madresfield Court, and Mrs. Pince, are frequently superior to quite black examples. So they may be if the black bunches are eaten before they are ripe. As before mentioned, Grapes may be red and yet good to eat, and, on the other hand, I maintain they may be blue black and yet quite sour. It is a mistake to imagine that because they are perfectly coloured they must perforce be ready to cut.

During August immense quantities of Grapes will be ripened in unheated and heated late vineries, and the aim of all alike should be to have these both well coloured and well ripened. The better they are grown the greater is the chance of keeping them well after they are ripe. July has been an exceptionally hot and dry month, and the Vines have evaporated an enormous amount of moisture compared with what has taken place about the same time in other years. This, I believe, materially checks root action and unduly hastens the maturity of the crops. It is the modern very highly constructed vineries that have been the most difficult to deal with, the greatest difficulty being experienced in maintaining both a moist atmosphere and a moderately high temperature. Even experts have found it almost impossible to prevent a rapid spread of red spider as well as the loss of much foliage by burning. Bushels of berries just at the stoning period have been either burnt or scalded, or if not burnt or scalded what is it? I shall not attempt to explain or define

the causes of this unusual occurrence, but allude to it in the hopes others may elucidate the mystery. It is a general complaint, especially as regards Madresfield Court, and where many bunches are badly disfigured employers ought not too readily to condemn the gardener in charge.

Where Grape growers are most to blame is in sticking to certain rules; as these, time-honoured though they may be, must be varied according to circumstances. For instance, many gardeners are under the impression it is a great mistake to shade Vines in any way. Such may be the case in very backward localities, but in Somersetshire at any rate we indulge in no such fads. By "we" I mean those who, like myself, are not in the habit of blindly following old notions. My plan directly it is seen very clear weather has set in any time in July or August is to lightly shade the Vines, with the result that if the Grapes are not quite up to Mr. Taylor's high standard they will yet be found hard to surpass. Hamburgs, Muscats, Foster's Seedling, Buckland Sweetwater, Gros Colman, Gros Guillaume, Gros Maroc, Madresfield Court, and Lady Downe's all received a light shading, and all are benefited thereby. A heavy and permanent shading would be injurious, but a little thin limewash or whitening syringed lightly over the roof will usually afford ample shade. A heavy rain will soon remove it, and it can be renewed in a few minutes. Now the Strawberry beds are cleared some of the bird or fish nets will be at liberty, and these loosely trailed over the roof wherever needed are excellent for shading the Vines—much better, in fact, than limewash. It is not yet too late to use either one or the other, the month of August frequently being very hot and bright.

It is generally admitted that black Grapes colour most surely under a canopy of strong leaves, and I venture to assert that the white sorts may also be beautifully coloured under plenty of foliage. If we expose the bunches to the full sunshine they will colour more rapidly, but an observant Grape grower can easily detect these prematurely ripened bunches. They colour wherever the sun shines full on the berries, but unless the bunches are so slung up as to well expose their whole length only the shoulders will be coloured, the remainder, especially at the back of the bunch, being very much longer in finishing. It is not direct sunshine white Grapes require. Give them time, plenty of light, and in the case of Muscats a rather warm temperature with air, and they will colour superbly under the leaves. The light should reach them through the spaces left between the laterals on each rod, or, if these are somewhat crowded, then the laterals ought not to meet each other. Some are under the impression that white varieties are more easily coloured than the black sorts, but this belief is not shared by the experienced growers. Grown and otherwise treated as well as the black varieties they will finish equally well, but if overcropped and treated in a haphazard fashion they will be of a dirty green tinge instead of the rich amber we so much like to see. For instance, Foster's Seedling may be so much overcropped as to be almost unrecognisable. Green Grapes keep badly and are rarely fit to eat.

Although black Grapes colour best in a comparatively low temperature and plenty of front night air, this treatment may be easily overdone, notably in the case of late keepers. Should the weather be dull and cold in August a little fire ought to be turned on, and it is still more necessary in September and October. A good circulation of warm air is necessary for ripening any kind of late Grapes, this being necessary for converting the juices into saccharine matter. If the latter chemical change is not brought about the fruit is not of good quality and will keep badly. Last year many Grapes shrivelled, owing, it was considered, and rightly so I think, to the maintenance of a too dry atmosphere, in September especially. Those who persevered in damping down had little cause to complain of shrivelling, and should September prove as fine and dry as it was last year, it is advisable to freely damp down the late houses at least once a day. We want plump Grapes, not raisins, and we must therefore avoid the conditions that convert one into the other.

Those who wish to colour Gros Colman properly must keep it well supplied with water and liquid manure up to the last. With us it is one of the first to colour in a mixed late house, and it continues to swell and colour nearly up to November. Three months is a long time for a Grape to be colouring, but that is the time it takes with us. Those, then, who find theirs colouring slowly need not despair. At any rate, it is unwise to attempt to unduly hurry it, either by giving less water or by raising the temperature higher than is good for the other occupants of the house.—W. IGGULDEN.

#### ARTIFICIAL MANURES FOR DRY WEATHER.

IN a season so abnormally dry as the present it is well to note every little thing which has a good effect on vegetable life. It is impossible in British gardens to apply water to every crop, and there-

fore it is the more necessary to be prepared for drought when it comes. It is a pretty well known fact that artificial manures applied to crops in dry weather have no good effect whatever. Moisture in all cases is a potent factor in securing the success of these. It is not only potent, it is indispensable, and as a natural consequence artificial manures are in a dry season of generally poor effect. But this remark applies more immediately to the less soluble constituents of good manures, more especially to forms of potash, but also to phosphates. This year I have noticed several cases in which dressings of nitrogenous manures have had an effect of a most marked character. But the manures were not applied late in the season but early, and the earlier the dressing the more marked has been the good effect. Grass for hay surfaced early with nitrate of soda has produced a fairly good crop. Late-dressed or unmanured fields have been very poor indeed. Two adjoining fields of Wheat, the one dressed late in April with the nitrate, the other unmanured, has all through the summer shown a marked difference in favour of the crop that was dressed. In garden crops with Onions, for instance, a dressing of sulphate of ammonia applied in April has secured us a good crop, many of the selected plants being of as good quality as beds which have been regularly watered.

The reason of these results following an early dressing of either of these manures in such a dry season as the present would appear to be, that the plants so treated begin to make a more vigorous growth while plenty of moisture is in the soil. Roots are more freely produced, perhaps as a consequence, possibly as a matter of tops and roots acting the one on the other reciprocally. Doubtless also the other manurial agents of whatever nature contained in the soil is rendered more available to the plants, and certainly both nitrate of soda and sulphate of ammonia have such a strong liking for water that this of itself must be very beneficial. Of course I do not underrate the advantages to be derived from other items going to make up what is called good cultivation, such as a deeply worked soil, mulching, &c., but give these remarks merely in the way of a help when every little thing is needed to make crops grow.—B.

#### GAILLARDIAS.

AMONG choice hardy perennials Gaillardias should always be found. Their average is about 2 feet, though in wet seasons they will attain in some varieties to nearly 3 feet in fact by trenching the ground and manuring freely you may almost tempt them in any season to the latter named height. It was in the spring of 1880 that I planted a bed of these flowers, and among them a fair proportion of *G. grandiflora maxima*, a variety which I note has been certificated quite recently at Kensington, though it has been in nurserymen's lists for years. I did not see the plant which received the certificate, but the variety I grew under the name was at least 4½ inches across, such flowers as these it produced abundantly and profusely. Without a single exception the whole of these attained to about 3 feet high, but I did not admire them on this account, as they needed staking, which the others do not.

Originally Gaillardias were confined to those colours which made them figure so conspicuously among other plants in the herbaceous border—namely, orange, crimson, and gold. Often these three predominant colours may be found in well defined circles in one flower, and who will gainsay that such a combination as this is not calculated to make up a flower of unsurpassed gaiety? It is worthy of note, too, after attending many exhibitions, and having exhibited these flowers among other hardy plants, that I have not the slightest recollection of anyone not appreciating them; in fact they always seem to be foremost among the admired, and I doubt not when the public have become persuaded of their hardiness and strictly perennial character they will be much more largely grown than hitherto. In point of colour Gaillardias are evidently undergoing a change, for now among seedlings we frequently find gold selfs, also flowers made up of orange, and others still merging into canary yellow. This year I have some plants of a soft yellow, an exquisite flower, the general tone and aspect being such as one can admire unceasingly without fear of tiring; besides, being a self-coloured flower, the disc is of the same colour as the florets, which is not usual.

But there is yet an important point to consider in respect to these flowers. As regards their culture I need say but little, for any well-enriched border will grow them to perfection, and given full sun they will form a really sumptuous display in themselves. Then as to getting a stock of them. Well, for the matter of that, they came most freely from seeds, which should be sown in January, and most of the plants will flower during the year, provided they have the requisite attention and are planted out as soon as they are established in their pots, into which they need placing singly when large enough to handle conveniently. They do not, however, show themselves to advantage till the next season, when they spring up into large tufts and are laden with their flowers and buds. We must have other methods of propagating the best varieties—I mean the selected forms from the seedlings. We cannot depend on seeds for these, for there will hardly be two alike, so that we must resort to cuttings, divisions of the rootstock, or root cuttings. The latter is perhaps the best of all. Almost every scrap of root will grow, so that with care and discretion a stock of young plants may soon be obtained, and they are worth atten-



tion in this respect. To a certain extent, but not in the same quantity as root cuttings, they may be increased by division, and for cuttings these must be secured in spring just as growth commences. For propagation by root cuttings, all that is necessary is to cut them into lengths of an inch or thereabouts, and place in a perpendicular position around the interior of some pots or pans in sandy soil, and if a gentle bottom heat, such as that afforded by a dung frame, be at hand this will make a capital place for them. Leave the apex of the root just emerging from the soil, and in a few weeks signs of new growth will be apparent. In large establishments or small—anywhere, in fact, where flowers are in demand in a cut state—these Gaillardias should be largely grown; they continue for a week or ten days in perfection, and this during the recent hot weather, especially so if the flowers are cut in the early morn instead of in the heat of the day.—J. H. E.

### STRAWBERRIES FOR FORCING.

THOSE that are in the habit of relying upon fruiting plantations to yield the supply of runners for next season's plants for forcing in pots will this season experience some difficulty in securing the requisite number. The plants have been subjected to greater hardships than has been the case for many years. The long trying winter, followed by a late cold spring, and then six weeks of very hot dry weather, has affected the plants to such an extent that they have nearly collapsed under the strain of fruit-bearing. Such is the condition of plants on our light sandy soil. They certainly looked well and luxuriant until the fruit was set, and although a fortnight late gave promise of producing good runners; but this hope has not been realised, for as the fruit swelled and the dry weather continued the perfecting of the crop proved too great a strain, and the plants are still practically runnerless; in fact, what there is are poor and weakly, and would, if used for the purpose in view, be long before they attained sufficient strength to grow vigorously.

Where a large stock of plants are required for forcing, the wisdom of planting annually in the early part of September, and the plants retained specially for this purpose by the removal of the flower trusses in spring, will commend itself more forcibly to the majority of cultivators. Many of the largest and best growers have long since recognised the value of this method of culture, whereby earlier and stronger runners can be obtained than can possibly be the case from plants that are exhausted by fruit-bearing. Runners from young plants are in the majority of cases free from red spider and yellow thrips, which in seasons like the present are certain to attack old plants that are carrying a heavy crop of fruit. If these plants become a prey to the insects the runners, if any are produced, are not likely to escape being attacked. If the system advised is practised most of the anxiety in securing good runners for layering will be removed, and valuable autumn and spring crops can be taken from the ground between the rows. For instance, Endive, Leeks, Cabbage, Turnips, or any dwarf-growing Broccoli, such as Osborn's Winter White. In spring the ground can be used for Lettuce, Radishes, early dwarf Cauliflowers, or any such purpose. Any of the autumn crops can be planted at the proper time and the Strawberry plants between them when ready; this is our practice when we want a crop from the ground, which we invariably take both in the autumn and spring.

Young plantations have this year, however, done worse with us than for at least a dozen years; in fact, during my gardening career I do not remember such a scarcity of runners. Many plants failed in spring and many others have not grown well. We have generally had all layered by the middle of July, and all the earliest severed from the parents by the first week in August. It is questionable if we shall have all layered by that date. In the more southern parts of the country growers may be better situated for runners, but in the northern counties there is more to layer than has been layered. The prospect where the land is heavier and more retentive of moisture than ours may not be so gloomy.

If we take into consideration the majority of seasons we have experienced lately, mulching early in the season for the purpose of arresting evaporation and insuring the ground about the plants remaining moist during dry weather might safely be regarded as a waste of time and labour. In many seasons this certainly has been the case, and mulching has not been needed for the purpose indicated. It is, however, a safe practice that should be more generally followed, for if the season proves of the most showery description no harm results to the plants from being mulched, and if the weather proves the reverse then the advantages of the system cannot well be over-estimated. Those that follow a judicious system of mulching have reaped the benefit this season in having stronger plants, better and earlier runners, than those who ignore this method of culture. One half of our fruiting flat had the ground covered early with clean straw, and the other was delayed for at least a fortnight longer until the ground became dry. The result is that there

is a marked difference in the appearance of the plants at the present time, and the size and quality of the fruit has been much better on that portion where the ground was covered while in a moist state.

For years we have been in the habit of layering into the large pots, and we are firmly convinced that no other method can excel this one, for it is the most economical as regards labour, while the results in spring are most satisfactory. The plants grow from the first without any check, which is not the case when layered in small pots, for they are too frequently dried up in their early stages, and invariably checked during the process of transferring them from the small to the fruiting pots. We carefully tested the matter some years ago by raising half our stock of plants on the one principle and half on the other, and the advantages throughout were in favour of those layered into their fruiting pots.

Circumstances alter cases, and this year we foresaw the difficulty we should experience in getting runners, for the young plantation had not been mulched and the plants had not done so well. Previous to gathering fruit we went over the portion of fruiting plants that had been mulched and took every runner that had commenced expanding its leaves. These were potted in small pots, placed in a frame and kept close and shaded: they are now vigorous young plants well rooted; in fact, nearly half of them have been transferred into their fruiting pots and the remainder will be ready in a few days. Having plenty of frame room just now the plants will be given close treatment in frames until they commence rooting freely in their largest pots, when they will be hardened and stood outside. By this method we have secured a thousand good plants, which if they had remained on the parents would have made no progress and many would have been destroyed by gathering the fruit. These made such excellent progress in the small pots that we placed some three hundred fair sized runners into their large pots so as to save the labour of repotting them, and these are doing remarkably well; so well, in fact, that we consider the plan an excellent one, especially for those who have abundance of frame room at liberty and who grow large numbers of plants for market purposes. Economy of labour must be the first consideration of those who grow with this object in view if they hope to be rewarded with satisfactory returns, and this is certainly a less laborious system of any I have yet practised, even than layering in the fruiting pots. I do not wish to convey the impression that growers for market only have to consider the easiest method of production, for in most private establishments at the present time economy of labour is and must be one of the first principles of management.

Directly we observed that runners would not be very abundant a good number of plants in pots that produced the latest supplies of fruit were retained for the purpose of giving runners. They were hardened and stood for a time in a sheltered place to save as far as possible labour in watering. Under these conditions runners were put forth plentifully, and many of them are now sufficiently advanced for layering into pots. Before this is done, however, the plants should be brought to a more sunny position and their pots plunged to the rim, which will prevent the plants drying so rapidly as would otherwise be the case if fully exposed on the surface. A good number of plants plunged in pots in close proximity to the water supply will not entail much labour in keeping them supplied with water. Keeping the plants in their pots until all the runners required has been removed from them is a better practice than planting them out for the same purpose. If placed out they would have become seriously checked in addition to giving much trouble in watering, for the balls of roots of those grown in pots are very firm, and without very great care after planting out they could not be kept soaked with water.

As soon as the stock for forcing in pots has been secured no time should be lost in raising those intended to form new plantations, either for fruiting next year or for affording runners for layering. For this purpose we prefer, because it entails the least labour, to cut off the runners and insert them in small pots and place them in a frame where they can be kept moist and shaded until rooted. If carefully hardened afterwards and planted during showery weather on well-prepared ground they will grow without the least check, and become well established before winter. We have inserted them in boxes and amongst leaf mould in frames, but they generally receive a check when planted out and stand still for a time in consequence. This should be avoided, and can be done, by placing them in small pots when severed from the parent plant.—A NORTHERNER.

### THE RECENT DROUGHT.

ALTHOUGH the recent drought did not commence until the beginning of June, it appears from an examination of the meteorological records that in most parts of the country the whole of the present year has been unusually dry. Up to the end of May the aggregate

rainfall had been 25 per cent. less than the average in the north-west of England, 32 per cent. less in the south, 34 per cent. less in the north-east and east, and as much as 48 per cent. less in the south-western districts. Over England, and especially over the midland and south-eastern counties, heavy falls of rain were experienced on the 3rd and 4th June, after which time no material amount was recorded until the present week. During this long interval there were over England from twenty-five to thirty consecutive days on which not a drop of rain was measured, and, in addition to this, it appears that in most instances the showers which immediately preceded or followed the period of actual drought were so trifling as to be altogether valueless in their effect upon vegetation.

In order to gain a clear and definite idea as to the relatively severe nature of the recent spell of dry weather, a careful examination has been made of the London rainfall values for the whole of the past twenty-three years. In dealing with this vast mass of information some doubt arose as to the standards which should be employed in defining periods of drought, but it was ultimately thought best to pursue the same methods as those recently employed by Mr. G. J. Symons. In a paper on the dry weather of 1884, Mr. Symons suggested that droughts should be divided into two classes—viz., "absolute" droughts or periods of at least fourteen days with no rain at all, and "partial" droughts, or periods of at least twenty-eight days in which the total amount of rain (irrespective of its distribution) is less than a quarter of an inch. On looking over the records for the past twenty-three years it appears that the long period of absolute drought recently experienced in London, lasting as it did for no less than twenty-five days, has not been equalled since the year 1865. In that year there was a total absence of rain from June 3rd to the 28th, a period of twenty-six days. Between that date and the present time there have been nearly forty instances of absolute drought, but only three occasions on which the absence of rain has been felt for a period of three weeks or more. Looking at the recent drought from the second point of view, we find that the period of "partial" drought recently experienced in London lasted from June 4th to July 14th, or no fewer than forty-one days. This was a decidedly longer period than any recorded during the past twenty-three years, the nearest approach to it being in 1874, when there were thirty-eight days with a total rainfall of less than a quarter of an inch. Since 1865 there have only been four periods of drought lasting over five weeks, but in 1870 there were more than four weeks of partial drought between March and April, and nearly five weeks between May and June.

Although the statistics just quoted are for the London district alone, they would probably apply in a general way to nearly all parts of our midland, eastern, and southern counties, where the recent drought has been fully as severe as it has been in the metropolis. During June the aggregate rainfall in Norfolk was only two-tenths of an inch, and in Mid-Devon little more than one-tenth; while in Cornwall and some parts of South Wales it amounted to only a few hundredths of an inch. The effect of so much dry weather has of course had an additional influence on the aggregates for the whole year, and from the weekly report just issued by the Meteorological Office we find that up to July 18th the deficiency of rain since the beginning of January amounted to 37 per cent. over our eastern and southern counties, 40 per cent. in the Midlands, and 45 per cent. in the north-east of England. In the south-west of England, embracing the counties of Somerset, Devon, and Cornwall, with South Wales, the aggregate for the year amounted to only 42 per cent. of the average, or considerably less than half. Under such circumstances the recent complaints from Swansea of a scarcity in the water supply are by no means surprising. The recent dry weather has been due in a great measure to the unusual prevalence of anti-cyclonic conditions, but partially to other causes of which at present very little is known. There can be no doubt that at times a distinct tendency is shown for the weather to be either dry or wet, and in the same way to be either hot or cold. This tendency asserts itself in a manner altogether irrespective of the conditions of barometrical pressure prevailing at the time; and although there is no reason to believe for a moment in the exploded theory of sunspots, or in any other of the quack notions which are from time to time advanced, there can be little doubt that our weather is affected by great cosmical influences, the origin of which remains at present a profound mystery.



### WILLIAMS'S ORCHID ALBUM.

VOLUME VI. of this beautiful work is an admirable addition to those previously issued. It is characterised by the same high quality in printing, paper, and binding, while the plates are most truthful representations of the plants portrayed, the colours being excellently reproduced. The subjects selected for illustration are varied, comprising six *Cattleyas*, five *Laelias*, four *Dendrobiums*, seven *Odontoglossums*, two *Cypripediums*, two *Lycastes*, two *Masdevallias*, three *Oncidium*s, two *Phalænopses*, two *Sobralias*, two *Vandas*, together with representatives of the genera *Aerides*, *Bras-*

*savola*, *Galeandra*, *Habenaria*, *Lissochilus*, *Saccolabium*, *Trichocentrum*, and *Thrixspermum*. In addition there are twenty-nine short articles upon topics of interest to orchidists, including an obituary of the late Mr. Thomas Moore, some of whose latest work is found in this volume. The technical descriptions of the plants figured, together with the general historical and cultural remarks, are most valuable, and the book altogether is a handsome addition to any library.

#### ODONTOGLOSSUM HARRYANUM.

THIS very distinct *Odontoglossum* was introduced a year or two ago by Messrs. Horsman & Co., Colchester, but as the stock subsequently passed into the hands of Messrs. J. Veitch & Sons, Chelsea, it was named in honour of Mr. Harry J. Veitch. At the last meeting of the Royal Horticultural Society Messrs. Sander and Co., St. Albans, showed plants of the species, exhibiting some differences in colouring, but the richest tinted form was selected for a first-class certificate, and a flower of this is shown in the woodcut (fig. 9). It is of the *O. luteo-purpureum* type in habit and form of pseudo-bulbs, but the flowers are very distinct from any other and very handsome. The flower is shown of its natural size in the illustration, the sepals and petals are broad, the former heavily barred with brown, and a few transverse greenish yellow



Fig. 9.—*Odontoglossum Harryanum*.

streaks; the lip is large, expanded, the upper portion white, the broader lower half has a yellow crested centre, the lateral portions richly veined with crimson purple. The flower has a peculiarly bold appearance, due in a great measure to the handsome lip, and it will certainly become a favourite amongst cool house Orchids.

#### VINE BORDERS AND UNORTHODOX PRUNING.

"EXPERIENTIA DOCET" favours me (page 4) with a remarkable, singular, and suggestive defence; remarkable for raising questions of matter not in dispute; singular in parading experience without advancing any in support of his "advocacy of long pruning Vines under certain specified conditions;" and suggestive as to on whom rests the futility of "labouring to prove that something that actually is could not be."

I have examined the article referred to. Is it genuine? That is matter of opinion; all that need be stated of it at present is I at least take it as "unorthodox."

"Inspecting Vines, studying Vines, working amongst Vines, trying to understand them, not only generally but the individual peculiarities of peculiar Vines," "for no one knows how many years," is enough to impress anyone, not excepting those that have "swept the boards" on many occasions, won "gold medals until tired of winning, and prizes of the value of £300." It does not appear that "Experientia docet" has been successful in doing more than meet the requirements of the "owner of the Vines that wanted Grapes." Perhaps your correspondent is not aware that the most crucial test to which Grapes are

subjected, and everything horticultural for that matter, is not the ordeal of the exhibition but the dining table.

In "Experientia doctet's" first communication long pruning and nothing but long pruning was the theme, and so in harmony was it with my feelings—so likely to give fruit abundantly in due season—that I gave him a review, which proved acceptable. Anyhow, it is acknowledged, page 389, May 19th, 1887, in view no doubt of another "review" equally as favourable; but his reviewer had the audacity to question his deductions. Allow me to assure your correspondent that it was with a desire to give his long pruning its place that I replied to his letter. I did not, and do not, think unorthodox pruning entitled to credit for producing better results in Grape-growing under the specified conditions indicated, therefore felt it incumbent to counteract the tendency of such teaching. That I have endeavoured to do as a simple duty, for who could have dreamed of such a treat being in store for the readers of the *Journal of Horticulture* at the beginning of the dog days, as that we are favoured with (page 4) by "Experientia doctet?" When everybody was overwhelmed by heat it came (to me at least) as a refresher. Our friend will perhaps now see the propriety of leaving the back seat and take a front one, as we (the orthodox) are liberty-loving enough to allow him to sit where he pleases, all seats being free.

Now for the practical side of the "advocacy of long-pruning Vines under certain specified conditions," which, as before stated, had no relation whatever to "border influences in improving the Grapes," but now (page 389, May 19th, 1887) credit is given to fresh soil and manure, yet he has the boldness to assert that the Vines at Cole Orton Hall and The Firs owe their bettered state to long pruning. I do not think the Vines at Cole Orton Hall help "Experientia doctet," for, according to his own showing, long pruning is unnecessary when Vines root freely near the surface of a good border, and the growths are trained thinly and the foliage clean. Mr. Henderson, it seems, set to work like a sensible man, pruned on the principle of selecting, and cutting to the best eyes, let them be situated where they may. Yes, Mr. Henderson was a "sensible man"—i.e., first "caught the hare" before giving instructions how it was to be cooked; cut hard back—an orthodox practice, got fresh canes, and rejuvenated the Vines. That, with border renovation, is, as I take it, the cause of Mr. Henderson having "swept the boards" on so many occasions. As to the Vines in the brick frame winning £300 in prizes, the Vines had not only the advantage of a properly made border, but they were "top-dressed, and fed with the right food, and in right quantity, and at the right time." Yet we are asked to note "the fact that the pruning was unorthodox" in the laterals being shortened to the "best eyes." Mr. Henderson is clearly on our side. The old Vines had gone wrong. Refusing to answer to the spur, the rod was brought into play. Mr. Sanders acted no doubt wisely in dressing the border with lime and applying fresh soil and manure. But I am reminded of overlooking the fact that in one instance the results of the long pruning was unmistakable; there were the two systems together—the orthodox and unorthodox—and the latter had the "best Grapes." I fail to see that the roots were beyond control, but they had the benefit of a favourable rooting medium. The Vines, it seems, only wanted a chance, and got it—increased vigour by encouraging growth and maintaining it.

Perhaps "Experientia doctet" will explain what he means by "orthodox nonsense." Tell us of a case where Vines in a cold wet border have been made by long pruning alone to yield satisfactory crops of Grapes. If not able himself, perhaps he may be in a position to refer us to some veteran that has made Vines grow fruitful in a border composed of unsuitable rooting material. Your correspondent's intention is no doubt good, but he forgets there are cases in which no remedy is effectual save a thorough renovation of the borders, and that his remarks on long pruning being a panacea for unfruitful Vines may lead to that extension of the premises he portrays. That is an aspect of the question not to be overlooked, as it is calculated to make victims of orthodox brethren, whilst leading the unorthodox further astray. Return, brother of the spade, to the pathway of the orthodox, in which provision is made for the Vines to take root downward and bear fruit upward, bringing with you the wanderer back to the fold.—G. ABBEY.

## INDIAN EXPERIENCES.

(Continued from page 526, last vol.)

### THE COFFEE LEAF DISEASE.

As stated in my last paper, I returned in 1871 to the Wynaad from the Neilgherries, after an absence of some five years, to find matters relative to Coffee planting greatly altered. As a crowning blow to the hopes and prospects of the planter, leaf disease had taken firm hold of the plantations that had struggled through all the other ills that the Coffee plant is heir to, and was making such rapid and destructive progress as seemed to have paralysed the planter and well nigh caused him to give up in despair. The disease appeared first in Ceylon a year or two previous to the above date, then amongst the Coffee estates of Travancore, the most southern limit of Coffee cultivation in India. From Travancore the malady gradually travelled northwards till it reached Wynaad, Coorg, Mysore, and the most northern limits of the industry. With regard to Ceylon, I believe that at the earlier stages of the leaf disease Dr. Thwaites unhesitatingly recorded his opinion, after close and careful examination of the subject, that the disease would only finish its march of destruction with the death of the last Coffee tree in the island; and although he subsequently modified this opinion, I, for one, am inclined to believe that Dr. Thwaites' first impression was

a correct one. It is at least quite certain that no more formidable enemy, or one more difficult to attack and subdue, has ever appeared on the earth to test the powers of scientists and the patience of any community of cultivators. To accurately describe the ravages of this mysterious fungoid growth on the leaves of the Coffee trees, and the consternation it caused throughout the Coffee districts of Southern India, is no easy task. I had seen the Potato blight in its worst form, as well as other kinds of plant diseases and injury by insects in England, and of course I had come face to face with the wide-spread injury caused to Coffee plantations by bug, horer, drought, &c., but such an affliction as this leaf disease, at once so rapid, devastating, and ruinous in its nature, I had never before seen, nor even dreamt of. It took a stout heart on the part of any planter to boldly face the difficulty, and after the first shock had passed over to begin courageously to battle with the disease and endeavour to eradicate it by a higher system of cultivation than he had previously resorted to. This was done in numerous instances, and large sums of money were again spent in artificial and other manures in order to sustain the vigour of the plant and, as it was supposed, to render it less liable to the attacks of the fungus; but up to the time I left the country in 1877 all this expenditure of energy and money had resulted only in a partial and limited degree of success.

The fungus could be seen more or less on the leaves of the Coffee bushes throughout the whole year, but the time of its greatest appearance was between the ending of the south-west rains—about the middle of September—and the end of crop-gathering—the end of December. At the latter date it was no unusual sight to see plantations denuded of leaves and with quantities of fruit of a greenish yellow colour, which refused to ripen, and which had to be gathered in that state, dried in the cherry, and afterwards pounded out in mortars, yielding Coffee of a very inferior quality. The fungus, or rust as it was sometimes called, first appeared on the leaves in the form of spots of a bright orange-red colour, which gradually merged into each other till the whole of the back of the leaf became covered with a thick coating of the fungus, resembling a red powder, staining the fingers freely when touched. On the first appearance of the fungus in the form of spots alluded to above, each spot contained a small worm about 3-16th of an inch in length, which could be easily seen by the naked eye; but whether this little worm or maggot was the outcome of the growth of the fungus on which it fed, or whether it was the attack of the insect on the leaf which caused the growth of the fungus, no one seemed to be able to say, but the presence of the insect was an undoubted as well as a curious and interesting fact. As the fungoid growth spread on the under side of the leaf the upper surface gradually became yellow, owing no doubt to the tissues of the leaf being destroyed and ending in the leaf falling. The disease was not confined to Coffee under any particular condition as regards culture, but appeared everywhere, on highly cultivated estates, on estates receiving cultivation only in name, on the trees remaining on abandoned plantations, and on trees that had sprung up from stray seeds in the jungle, so that it would appear that the disease was propagated by the spores floating in the atmosphere, detecting a congenial lodging place on the leaves of the Coffee plant, wherever or in whatever condition found.

An idea sprung up in the minds of a number of planters—after it was found that the highest cultivation it was possible to adopt had but a limited effect in checking the disease—that such a deterioration had taken place in the constitution of the ordinary Coffee grown in Southern India from some cause unknown, that it was absolutely necessary to procure "fresh blood" in the form of a distinct species of Coffee, possessing, if possible, a more robust constitution. Just at that time the Liberian Coffee was much spoken of, and an English firm of nurserymen was raising plants from seed procured direct from the West Coast of Africa for export to India or elsewhere to anyone wishing to try the experiment. I was induced amongst others to order a Wardian case of plants to be sent out, which was done very promptly by the firm alluded to. The case contained seventy plants in thumb pots, and so admirably were they packed that every plant reached me in perfect health after a voyage and journey covering some forty days. The case reached me in December. I opened it at once and shifted the plants, which were then only about 3 inches high, into larger pots; they at once started into growth, and by planting-out time had grown into strong, healthy plants of an average height of 1 foot. These I planted out very carefully on a piece of good land on a new plantation I was then engaged in forming. The plants did not make much progress in the open ground during the continuance of the heavy monsoon rains; but as soon as these began to moderate the plants began to grow rapidly, and by the time the dry weather had fairly set in had produced shoots of a very satisfactory growth, and leaves of an enormous size in comparison with the ordinary Coffee of the district. As time went on I found traces of the leaf disease on the young Coffee trees of the ordinary type, of which I had planted some 150,000 at the same time as the Liberian species; but no appearance of disease of any kind on the plants from England.

Matters grew gradually worse with the common species of Coffee on the estate till at last they were utterly divested of every leaf and left to weather the ensuing hot season under bare poles as best as they could. The Liberian plants resisted the disease for such a length of time that I thought they were going to be proof against it; but in this I was mistaken, they caught the contagion at last and perished more rapidly than the plants of the old species of the same age. This was a very disappointing and disheartening experiment to me. It cost the respectable sum of 500r., or £50, which was, of course, thrown to the winds. I may also add that this particular plantation, although formed



under the most favourable circumstances with regard to richness of soil, abundance of water, favourable aspect, &c., had to be abandoned long before the period at which it ought, under ordinary circumstances, to have yielded its first crop, and this solely in consequence of the leaf disease. It would appear from the above experiment that the disease was propagated by atmospheric influences alone, and was not the result of any inherent weakness in the ordinary Coffee of the district produced by raising plants from the same seed for a number of years, as was supposed at one time by many planters.

Estates at high elevations escaped the scourge of leaf disease for a considerable time after it had wrought such havoc on estates at an average elevation of 3000 feet, but eventually it reached them, but hardly with such disastrous results, the colder nature of the climate at these higher elevations helping the plants through their seasons of privation. When an estate suffered to such an extent (I mean on the lower elevations) as to leave it without a single healthy leaf by the end of December—which was often the case—it was usual to prune the trees back severely, the primary shoots coming under this operation, which, under more favourable circumstances, were never touched. Manure was then given to the roots to the greatest extent possible, and with the first rain the trees at once started into growth, and were quickly reclothed in verdure, but of course no hope could be entertained of a crop for the next season, the tree only producing fruit on the one-year-old wood. All would go well up to the bursting of the monsoon, and throughout all the rainy months. When the rains ceased the trees presented generally a very beautiful appearance, covered with long freshly made shoots and glossy leaves, but only, alas! to succumb to the attacks of the fatal fungus as soon as the dry weather again set in, and thus the battle went on till the year I left India; in some instances the planter continuing the unequal contest season after season, while others, not believing that any ultimate good would result from such an expenditure of money, abandoned their properties to the indigenous growths of the country, which quickly obliterated every trace of the Coffee shrub and former cultivation. Many planters are, I am given to understand, even up to the present date, continuing the fight, but with what result I am unable to say; but I know, that notwithstanding all the efforts to counteract this disease, they have not succeeded in driving it from the land.

With one exception I never found the fungus attack any other plant, even in the near neighbourhood of plantations suffering from the disease. This exception was in the case of a large timber tree—*Lagerstrœmia microcarpa*. The leaves of this solitary tree were to all appearance affected by the same kind of fungus, but it did not seem to spread to other trees, and the disease may be said to belong essentially to the Coffee plant, but its origin and gradual dispersion over Ceylon and the Coffee districts of Southern India is enshrouded in mystery.

To make matters still worse for the Coffee planter of the Wynaad, if that could possibly be, the great Madras famine took place during the last two years of my sojourn in India—viz., 1876-77. This dire calamity resulting by some computations in the death of nearly six millions of human beings in the Madras Presidency, affected the Coffee planter in several ways. Labourers came in from the Mysore to the estates in such a wretched condition from a long-continued scarcity of food, that they were wholly unfitted for work, and in hundreds of instances only arrived on the plantations to die, and their bodies in too many cases to go without burial. Hundreds perished by the waysides, their unburied bodies becoming the prey to wild animals of various kinds, the planters and even the representatives of Government itself in this wild district being quite unable to meet the emergency. The sights seen all over the district were appalling and revolting to the last degree, and can never be effaced from my memory. Every effort was made on the part of the planters to mitigate the distress, but under the circumstances they could do but little. Each and every hut on the estates was transformed into an hospital, full of men, women, and children, perishing from hunger and disease, and receiving no response to their piteous cries for help. In the district of Wynaad itself there was no actual failure of crops, as the total failure of the south-west monsoon in that region was never known, but in the Mysore country it was different, and as sufficient grain could not be produced in the Wynaad for the consumption of the imported coolies, and as the famine extended all over the Mysore territory, it followed that when the bands of labourers arrived on the Coffee estates, if in some cases able to work, could find little or no grain to purchase with the wages received. Grain was imported at the instance of proprietors of estates from Bombay, and even Burmah, but only in insufficient quantity to supply the working portion of the estate coolies, and as the district was far from the centres of Government relief arrangements, little could be done for those who were unable to work, and great mortality followed in consequence. It was very remarkable the quiet behaviour of the labourers under these fearful circumstances. No attempt was ever made to loot the small stores of grain on the different estates, although any step in that direction could not have been successfully met by the planters. Seemingly, the natives preferred quietly to suffer starvation and death rather than break the law, and this was characteristic of their conduct, not alone in the Wynaad, but all over the Madras Presidency, during those two dreadful years. Previous to this famine it was the general belief that the eyots of Mysore had enough Raggy and other grain stored in the underground granaries to last out the longest period of any famine, but the fallacy of this belief was soon revealed after the first six months of 1876 had passed. The English nation responded nobly to the urgent call for help, and if I rightly remember, something like £600,000 was sent out for the relief of

the perishing thousands. This sum together with that voted by the Indian Government doubtless saved innumerable lives, but relief could only reach certain centres, such as the town of Madras and other large towns along the lines of railways; the districts and towns remote from these means of communication suffering beyond the belief of all except those resident in the particular districts at the time. Could the terrible evils and consequences of an Indian famine be fully realised by all those engaged in the legislation of the Empire, they would, I imagine, throw fewer obstacles in the way of any scheme of irrigation or other work having for its object the prevention of any such disaster as overtook a large portion of Southern India during 1876-77, resulting in the death of some six millions of the native population.

This closes my remarks on the district of Wynaad. The little I have to add in my concluding papers will be devoted to subjects in connection with the Neilgherry Hills.—PLANTER.

(To be continued.)

## ROYAL HORTICULTURAL SOCIETY.

JULY 26TH.

SCIENTIFIC COMMITTEE.—Present: Dr. M. T. Masters, F.R.S., in the chair; Messrs. Snee, O'Brien, Wilson, MacLachlan, Bennett, Smith, and the Hon. Sec., Rev. G. Henslow.

*Eryngium giganteum*.—Mr. Wilson showed a handsome spray of this plant, remarking that it was extraordinarily attractive to bees, which seemed to prefer it to all other flowers in blossom at the same time. He was not aware of its having been noticed as a "bee-plant," but strongly recommended it.

*Streptoarpus hy.*—An interesting series, raised at Kew, was exhibited, between *S. Dunnii* (male parent) and *S. Rexii* (female); also between *S. Dunnii* and *S. parviflorus*. Dr. Masters called attention to the great interest attaching to these plants, and to their curious habit of producing only one leaf subsequent to the cotyledons.

"Rust" on Plants.—Specimens of *Croton*, *Begonia*, *Bonvardia*, and *Solanum*, supposed to be attacked by rust, were received from Messrs. J. R. Pearson & Sons, Chilwell. They were referred to Mr. W. G. Smith for examination and report.

*Cypripedium Laurencianum Malformed*, received from Mr. Gordon, Twickenham. It was referred to Dr. Masters for examination and report.

*Dilophosphora graminis*.—A specimen of this curious fungus, which attacks ears of Wheat, destroying spikelets and disorganising the stem, was exhibited and described by Mr. Smith. It is local and erratic in its appearance. It occurred in South Bedfordshire.

*Fasciated Stems*.—Mr. Wilson remarked upon the prevalence of fasciated stems in *Lilium anatum*. Professor Church corroborated his observations by mentioning a similar occurrence in Kew Gardens. Mr. O'Brien observed that the habit has become more or less fixed in *L. lancifolium* when raised from bulbs, but nothing is known of this variety, monstrosity being raised from seed. *Appropos* of raising Lilies by seed, Mr. O'Brien remarked that if seeds of Lilies be saved and sown in South Africa they will flower within six months. Also, if English-saved seeds be planted in South Africa they will not bloom under a year; showing the influence of climate upon the development of the plant. The only Lily, Mr. Wilson remarked, which comes up quickly is *L. tenuifolium*.

*Nicotiana affinis*.—Mr. MacLachlan exhibited a blossom in a syanthic state.

*Laurel Leaves Recovering from Frost*.—Mr. Henslow showed a drawing and specimen of Laurel leaves which had been severely injured at their apices and along the margins in early spring, but which had thrown off the injured part and formed a new cuticularised edge in place of it. The serratures were wanting, so that the portions renewed were entire. They were received from F. C. White, Esq., of Ealing.

*Varieties of Wheat*.—Dr. Masters exhibited specimens of Wheat received from Messrs. Carter & Co., showing the extreme variations raised by them on well-known varieties.

*Glazing Bars for Glass Houses*.—A specimen was exhibited and explained by the patentee, Messrs. E. & F. Newton, of Hitchin and Stevenage. The merits of the invention lay in the facilities for allowing the glass to expand and contract under varying temperatures; and the method of conveying away the drip-water; also, in the ventilation, and the important point of price. In all these particulars the Committee were favourably disposed towards the invention. Mr. O'Brien and Mr. Snee undertook to report more fully at the next meeting upon the invention.

*Cattleya Gaskelliana*.—The Hon. and Rev. J. T. Boscawen exhibited splendid sprays of this Orchid, showing various tints. They were from plants imported in the spring of 1886. A vote of thanks was given to him.

*Conclusion of the Session*.—As the present was the last meeting of the summer session, a vote of thanks was passed to the Chairman and Hon. Secretary.

## THE INTERDEPENDENCE OF PLANTS.

At a meeting of the Philadelphia Academy of Natural Sciences some time since, Mr. Thomas Meehan called attention to the well-known fact in geographical botany, that species of plants which once had evidently a wide dispersion now existed only as separate colonies often of a few plants only, the intermediates between these widely separated colonies having evidently disappeared. The cause of these disappearances had not been definitely determined. It was found that the still existing individuals were evidently in good health; they flowered freely, and perfected seeds, but still the plants did not spread. He gave a number of illustrations within his own observation of a few rare plants that had maintained their existence for over a quarter of a century, with about the same number of individuals now as at the beginning of the term. As the seeding was regular and perfect, why was dispersion arrested? There could be but one answer. Something prevented the germination

of the seeds, or of subsequent growth after germination. No doubt there may be other causes, but this one must have a leading influence. It then becomes an interesting branch of study to inquire why these seeds do not germinate, and thus aid the plant to recover the ground lost through destructive agencies?

An observation extending over about six years led him to conclude that there was much in the interdependence of plants. Whatever affected the existence of individuals of one species might lead to the extermination of numerous others, and the successful endeavour of one to establish itself in one locality gave the necessary opportunity to follow and sustain themselves. This observation was as follows:—A wood, chiefly of Chestnut and Oak, of about an acre in extent, was turned into a picnic ground—a place for summer pleasure parties. All the shrubby undergrowth was cut away. The plants which might have grown up were kept tolerably well trodden down by the numerous visitors to the wood, except one solitary Blackberry plant (*Rubus villosus*), which, being thorny, led to its avoidance by human feet. After the second summer some change in railroad arrangements led to the abandonment of the wood for picnic purposes, and plants had a chance to grow up again without disturbance from human beings. The Blackberry plant, by the aid of its creeping roots, now forms a thicket of about 30 feet in diameter. The following list of plants growing among the Blackberries that were not found in any part of the wood, except the last two, which were in small quantities here and there, was made in October of this year:—

*Eupatorium perfoliatum*, *Rubus occidentalis*, *Liriodendron Tulipifera*, *Cornus alternifolia*, *Smilacina racemosa*, *Ambrosia artemisiifolia*, *Laurus Sassafras*, *Polygonum Persicaria*, *Achillea Millefolium*, *Solidago canadensis*, *Mulgedium acuminatum*, *Bidens frondosa*, *Silene verticillata*, *Fragaria virginiana*, *Aster longifolia*, *Eupatorium album*, *Circea lutetiana*, *Geranium maculatum*, *Acer rubrum*, *Phytolacca decandra*, *Muhlenbergia diffusa*, *Potentilla canadensis*, the last two to some extent in the wood.

All the kinds, however, grew in the vicinity of the acre of woodland, though not within its limits, and it was easy to note that they had grown from seeds falling or brought to the Blackberry patch during the last three or four years. Those who are familiar with the seeds of these plants will understand that there is nothing special about them that would easily lead to their being brought there by birds that might rendezvous in the thickets. We must look to the wind as the chief agent in transporting them there. This being the case, we should look for the plants from wind-sown seeds in other portions of the wood, as well as in the Blackberry patch. That they are not in the wood elsewhere permits us to say that the shade, moisture, preservation of decaying leaves, or of some other incident not acceptable to other plants in the wood, but favourable to these strangers, gave them the chance to sprout and grow. They were, in fact, dependent on the Blackberry for their first start in life. This conclusion was further evidenced by the fact that, though some of the annuals had evidently seeded and reproduced plants for several successive seasons, no plants were found spreading out of the protecting area of the Blackberry thicket. Certainly these species were all dependent here on this plant, as this plant would probably be dependent on others in some other instances.

How some plants can exist, grow healthily, produce seed, and not spread, Mr. Meehan illustrated in the case of *Shortia galacifolia*, the original locality of Michaux having a few weeks ago been rediscovered by Professor C. S. Sargent. Though it had maintained itself for the best part of a century, it had existed without spreading. Some circumstance had evidently prevented the seed from germinating, and these circumstances would undoubtedly be controlled by the presence or absence of some friendly plant.



AS will be seen from an announcement in our advertisement columns the NEWCASTLE-ON-TYNE AUTUMN SHOW will be held on August 31st, September 1st and 2nd, instead of commencing on August 30th, as previously arranged. It will be held in the Royal Jubilee Exhibition grounds, and the total amount of prizes is the largest yet offered by the Society, including £50 for collections of fruit. The Secretary is Mr. J. Gillespie, Cross House Chambers, Westgate Road, Newcastle-on-Tyne.

— ADJOINING the Show ground at St. Neots, Hunts, noticed in another column, one of MESSRS. WOOD & INGRAM'S NURSERIES is worth a visit, as although it is of moderate extent, and is employed chiefly for stock plants of Pelargoniums, it is extremely well kept, and the respective merits of the different varieties of the former plants are readily seen in comparative trials. Such valued bedding varieties as Henry

Jacoby, Vesuvius, West Brighton Gem, Lady Bailey, Master Christine, and Madame Vaucher, are grown by thousands—10 to 20,000 each. Of white varieties Huntingdonian looks remarkably well, compact in habit, very free, and pure; White Clipper is also a good bedding variety. Many others of the best Zonals are grown in quantity, and the beds devoted to them have a brilliant appearance. Bronze leaf varieties are similarly tested, and most notable amongst them are Zulu exceedingly dark; Black Douglas, and Beauty of Calderdale. Another specialty at this nursery are the Cucumbers grown for seed. A long span-roof house is now full of fine fruits of an excellent strain of Telegraph. The St. Neots nursery is only one of Messrs. Wood & Ingram's branch establishments, as their principal nurseries are in Huntingdon, where at the present time they have an extensive display of Carnations and Picotees in the best varieties of all sections.

— THE FLOWER GARDEN AT EASTON LODGE, DUNMOW, ESSEX, the residence of Lord and Lady Brooke, is one of the brightest and best filled we have seen this season, for bedding generally has, up to the present, been rather unsatisfactory. Many plants were retained in the houses longer than usual owing to the unfavourable weather, and when placed out they were somewhat tall, and soon lost their lower leaves. Difficulties like these have been avoided at Easton, the plants are all very sturdy and compact, and the majority are flowering very profusely. In the principal flower garden, which was noted in this Journal last year (page 232, Sept. 9th) the leading features are the long broad beds forming the outline of the design, which are filled with Pelargonium Manglesi and Verbena venosa mixed, with a narrow margin of Iresine Lindeni and a broad band of Cerastium tomentosum. These have an admirable effect, as also have some smaller beds filled with the variegated Ivy-leaf Pelargonium, the orange buff *Diplacus glutinosus*, and the blue *Agathæa cærulea*—a pretty combination, the pale pink flowers of the Pelargonium being freely produced. Bold masses of *Ageratum*, Pelargonium Vesuvius, Tuberous Begonias, produce a rich effect, Brighton Gem Lobelias being employed as a margin in most cases with *Echeverias*. In another portion of the garden are scroll beds of Golden Harry Hieover Pelargonium and Lobelias, with circles of *Coleus Verschaffelti* between the bends of the scroll, and small plants of the Golden Arbor-Vitæ in the centre. The Zonal Pelargoniums Henry Jacoby, and a large-trussing variety named Mulberry, are effective in other beds. A simple and distinct carpet bed and several good ribbon borders are similarly showy. The appearance of this garden generally well indicates the care and attention it receives from the gardener, Mr. H. Lister.

— "D., Deal," writes as follows respecting A GARDEN PEST:— "In reply to your correspondent who so mournfully tells of what he is suffering from these thread-like worms, I should like to ask him whether he is quite sure that they are the cause of his losses. He may think this Socratic method of meeting his case rather a heartless one, but I really mean it. What is his compost? What the manure? for it is odd that all these different kinds of plants should suffer at the same time from apparently the same cause; and my reason for asking is this. I have observed the same 'beasties' in those *Gladiolus* corms which had been attacked by disease, but I never believed that they could effect any injury upon the hard horny corm of the *Gladiolus*, and that it was only when it became softened by disease that they attacked it. In turning over heaps of manure (especially cow manure) I have frequently found large quantities of them. It is of course very difficult in all similar cases to say which is the cause and which the effect, but I would strongly advise your correspondent to examine well his compost and see whether there may not be something that disagrees with his plants, and whether it may not be that when they become weak these worms cluster round them. I do not pretend to write scientifically, but *meely* take a practical view of the matter."

— WORKING MEN'S FLOWER SHOW.—We are desired to state that "The Co-operative movement will be represented at South Kensington on August 23rd, on the occasion of the National Co-operative Flower Show, held under the auspices of the Royal Horticultural Society, which will be an exhibition of the products of *bonâ fide* working men's gardens, grown from seed sold in penny packets. The Show cannot help being interesting and instructive, as it will so thoroughly represent the gardening capabilities of small cottagers throughout the length and breadth of the land. Cheap excursions are being organised from all parts of the kingdom, and

Conference is to be held in the afternoon on the 'possibilities of Co-operative Allotments and Associated Gardens.' All persons who would like to attend should communicate with the Hon. Secretary, Mr. W. Broomhall, 1, Norfolk Street, Strand, W.C."

— **ROYAL WARRANT.**—Messrs. Dickson, Brown & Tait, seedsmen, 43 and 45, Corporation Street, Manchester, have received the Royal Warrant, appointing them "seed merchants" to His Royal Highness the Prince of Wales.

— **CEREUS GRANDIFLORUS.**—Mr. G. Goldsmith, Floore Gardens, Weedon, Northamptonshire, writes:—"For some weeks past several varieties of the beautiful Night-blooming Cereus have been flowering in Mr. Loder's garden. On several occasions we have had from six to thirteen flowers open, but on Thursday evening, July 14th, we had twenty-one Cereus grandiflorus, which was a grand sight, the size of the flowers varying from 11 to 14 inches in diameter. The perfume scented nearly the whole garden. The largest flower we have had measured over 15 inches."

— **WE** have received from Mr. Jupp, gardener to Cuthbert N. H. Johnson, Esq., of Croydon, the following effectual **REMEDY AGAINST RED SPIDER AND MILDEW**:—Take 2 lbs. of flowers of sulphur, 2 lbs. of unslaked lime, and 10 gallons of water, to which add two wineglassfuls of petroleum oil. Boil the whole for twenty minutes, but not violently, and when cold bottle and cork it tight. To use it put half a pint to ten gallons of water, to which add two wineglassfuls of petroleum oil, mix all well with the syringe, and apply it *in the evening only*.

— **THE Canadian** correspondent of the "Liverpool Journal of Commerce" says:—"It appears that the **APPLE CROP IN CANADA** promises to be a good one. Ontario has not suffered seriously from the drought which has been so disastrous in the United States, and the crops, as a rule, are in a flourishing condition. All kinds of fruit are generally reported to be abundant in the province, and, with a favourable harvest, the farmers will have little to complain of except low prices."

— **RAILWAY RATES AND PRODUCERS.**—The promoters of the scheme for the carriage of fruit and vegetables from Sandwich to London by water started upon a trial trip recently. A large amount of support was received from numerous growers in the Sandwich district, whose petition for a reduction in the railway tariff was refused. The freightage, consisting of Strawberries, Cherries, Currants, Gooseberries, Peas, and Potatoes, was placed in a barge, which was taken in tow by a steam tug. A somewhat squally sea was encountered off the North Foreland, and the hatches were kept battened down until some progress had been made up the river. London Bridge was reached shortly before midnight, and vehicles from the various salesmen conveyed the fruit and vegetables from the wharf to the different markets. The rates charged, it is stated, are about 35 per cent. lower than those demanded by the railway company.

— **WE** are informed that the "Flora of West Yorkshire," a volume of about 800 pages, by Mr. Frederick Arnold Lees, will be ready this month. It will be published by the Yorkshire Naturalists' Union, by subscription, and will form an extra volume of the Botanical Series of the Transactions of the Union. The work is divided into four sections—(1) Climatology; (2) Lithology; (3) the Botanical Bibliography of the Riding; (4) the Flora proper. With regard to the fourth section, it is claimed that "such a complete flora for any district in the world has never before been published, more than 3000 species being dealt with."

## DESCRIPTIONS OF AURICULAS—GREEN-EDGED.

(Continued from page 31.)

**Clegg's Lady Blucher.**—An attractive flower for a pointed petalled one with deficient ground-colour. Has many points of resemblance to Sir John Moore, and may possibly have had more to do with the parentage of that variety than the raiser thinks. Foliage nearly the same, deeply indented, light coloured, and flabby. Pip of good size, but pointed, and cups in cold weather; edge apple-green, sensitive of cold, which turns it cere; colour light purple, narrow; paste good, more than usually circular; eye deep orange yellow, often too much large; anthers low. Useful and pretty, but not first-rate.

**Dickson's Duke of Wellington.**—This, the pet of London growers, has a robust constitution, foliage light green, smooth, elegant in shape, and easily distinguished; and the flower though small and very faulty has certainly many attractions. Pip pointed, but flat; edge when pure,

which it often is not, light green, much too narrow, beaded; ground-colour rich violet plum, much too broad; paste of good substance and breadth, but scalloped; eye yellow but not deep yellow, bleaches after a few days.

**Dickson's Matilda.**—A plant of curious growth with a beautiful but far from faultless flower. The foliage is broad and dumpy, spreading, light green, healthy, with a curiously small serrated edge, easily distinguished. Pip the most evenly circular of all Auriculas, with broad petals, and opens with the beautiful cupped form of an opening Cowslip. Its edge is rarely light green, frequently grey, sometimes white, good in all forms; but it is most in character when a green edge; colour a beautiful violet purple of sufficient breadth; paste of the best; eye light yellow which soon bleaches, with concealed anthers. Apt to send up more trusses than are wanted, and more pips on each than it knows what to do with, as the footstalks are too short for a well-formed truss to be possible.

**Dickson's Prince Albert.**—One of that raiser's peculiar colour, and about of the average goodness of his flowers. The foliage is full green, symmetrical, keeping its shape equal to that of any Auricula; pip broad petalled, angular, flat; edge apple-green, pure; colour light violet purple; paste white, of good breadth, undefined at the outer edge; eye lemon, and bleaches; anthers on short stamens; fair trusser—keeps long in perfection except the bleaching of the tube.

**Finlayson's John Bright.**—Large coarse-looking plant. Sends up a pretentious truss that when examined has (say) five pips of extra size, that begins to open with great promise not warranted by the result. The green is pure and deep and the edge of sufficient breadth; colour deep clarety violet; paste thin but broad enough; eye lemon with concealed anthers; substance of pip leathery and flabby, and though it opens like Matilda it is angular; cups in cold weather. No acquisition. But it lasts as long as any, except Lovely Ann.

**Franklin's Colonel.**—A pretty rich-coloured and bright flower of no great pretension; not unlike Moore's Jubilee, to which it is greatly superior, or Litton's Imperator, which it may challenge; far more circular at all points than either; pip undersized, but well rounded, flat; edge pure grass green, too much broken into by the colour, which is reddish brown with a tinge of plum; paste circular, too narrow, thin; eye too large, cowslip yellow, which bleaches; short stamens covering the tube, anthers depressed. In general not a good trusser. Foliage deep green, broad, and smooth.

**Headly's Conductor.**—A decided improvement both in plant and flower on Beeston's Apollo. Good trusser; pip fairly round, even, flat; edge good grass green, pure; colour dark clarety plum, of good breadth; paste good, circular, defined; eye deep greenish yellow, low anthers; foliage deep green, ribbed, only partially serrated. To be depended on for exhibition purposes.

**Headly's Excellent.**—Small grower, of foliage intermediate between Conductor and Conqueror of Europe. Pip rounded, with large petals, smooth, and evenly reflexed; edge dark and pure green, like that of Morris's Green Hero, too broad, and more like the green of a leaf than of a flower edge; colour black and too narrow; paste circular, proportional; eye good, of deep greenish yellow. This also is a show flower.

**Heath's Emerald.**—A poor second-rate. Pip broad-petalled, round, flat; edge pure vivid green except the bead round the margin; colour dark maroon nearly black, not broad enough; paste good, broad, sharply defined; eye very small and circular, lemon, low anthers; calyx as large as the flower; moderate trusser; foliage smooth, fleshy, light green.

**Hepworth's Robin Hood.**—Very like Olliver's Lady Ann Wilbraham, but less angular and bold, and not so good a trusser. Pip flat but pointed; edge pure, deep green; colour deep chestnut dashed with plum, sufficiently bold, but not so much so as Lady Ann Wilbraham; paste often purely circular and always good; eye dark yellow and not too large; anthers low. A fine flower.

**Hogg's Waterloo.**—One of the flowers in which colour atones for many defects. Pip large, flat, rounded; edge narrow, light apple green, not always pure; colour bright reddish plum, too broad; paste scalloped, but sufficient; eye cowslip yellow with low anthers; foliage light and smooth, plant healthy; not a great trusser.

**Howara's Lord Nelson.**—A small-growing plant that may occasionally be shown. Pip broad petalled but angular; edge good but not pure, of sufficient breadth if it were continuous; colour dark velvety maroon breaking through the edge in broad irregular cones; paste thin, hardly broad enough; eye orange, of fair proportion; foliage dark green, glossy, smooth in the edge.

**Hudson's Apollo.**—If this were not too small it would be a formidable rival to Page's Champion itself, which it not a little resembles. If in comparison it is deficient in body colour, it is flatter and forms a more even and elegant truss. Pip flat and sufficiently rounded though still angular; edge vivid emerald green, pure; colour dark bright purple, or light mulberry, scarcely broad enough; paste very good in substance and width; eye circular, deep greenish yellow, stands well; anthers beneath the surface; excellent trusser. Plant healthy; foliage light green, veined, slightly serrated, clean looking.

**Lightbody's Fairy Queen.**—Nice second-rate flower. Pip round and flat enough, small; edge impure, apple green; colour reddish plum, streaky; paste round and good; eye orange, anthers low; good trusser. Foliage healthy, broad, even, serrated.

**Lightbody's Sir John Moore.**—A brilliant second-rate, which when it can be shown, and it sometimes can, may challenge almost any. It has



been exhibited in three out of the four classes and taken the prize in two. It is more bold and striking than Lady Blucher, the variety it most resembles, both in foliage and flower. The leaf is more bold, fleshy, flabby, and deeply serrated than that of Lady Blucher. The pip is circular, but has too many petals, tolerably flat, but has a habit of cupping its points; edge when green very light green, impure and beaded, often grey, sometimes white; colour usually a light Bishop's purple, but sometimes deepening to a maroon, occasionally hardly enough of it; paste very good in form and substance; eye always too large, irregular, light greenish yellow, tolerably stable; anthers very visible though not projecting; good trusser.

*Lightbody's Star of Bethlehem.*—Said to be the male parent of Sir John Moore. Pip pointed and too numerous in petals, but flattens as well as that of any Auricula; superb trusser; edge a pure but not very deep green; colour dark plum; paste of sufficient breadth, but undefined at its outer edge; eye lemon, too large, with projecting anthers; plan of average size with healthy foliage, slightly serrated. A singularly rich and flat-looking flower.

*Litton's Imperator.*—A small but free-growing healthy plant with narrow, smooth, recurved foliage, having its outer edges often lighter than the centre; perpetually splitting its heart and so sending up two or more independent trusses on long lanky stems. The flower is very showy. Pip large, angular, flat; edge pure, deep green; colour a rich dark brown, not always broad enough, but always lively from its irregular pencillings; paste circular, of sufficient breadth, but thin, and undefined at its outer edge (a great fault in any Auricula); eye of proper size, yellow, anthers not projecting; good trusser. It is impatient of cold in spring.

*Oliver's Lovely Ann.*—A thin flimsy flower, which nevertheless lasts the longest of all in its perfection, but is never either more nor less than second-rate. Pip pointed though often circular; edge light green, rarely pure, often grey, but its characteristic state is green; colour always too narrow, of a maroon so dark as to be a black; paste even, defined, sufficient; eye good yellow, not deep, but lasting, anthers low. The green edge though light, like that of Morris's Green Hero and Excellent, has the appearance of leaf green rather than as belonging to a flower. Moderately even in its truss. Foliage flimsy, deeply serrated; constitution healthy.

*Oliver's Lady Ann Wilbraham.*—A small plant, but of great value, though of low price. Pip large, full, flat, pointed; edge grass green, pure; colour deep maroon boldly put on, but not too broad; paste angular, defined, of good substance; eye deep yellow, good, with anthers sufficiently low; first-rate trusser. Its angularity prevents refinement or it would be surpassed by none. Foliage broad, veined, darkish green, not abundant.

*Smith's Lycurgus.*—A fine bold flower that trusses well. Pip circular, but not flat; edge deep green, impure, beaded; colour bold, black at first opening, expanding to a rich full brown afterwards, of good breadth; paste circular, of sufficient width, defined; eye good bright cowslip, which stands, circular, with short stamens. Foliage curled, long, much serrated.

*Smith's Lord John Russell.*—A small-growing plant with serrated foliage. Pip pointed, with too many petals, flat; edge tolerably pure, of the light green of Lovely Ann; colour reddish brown; paste fairly even, defined, sufficient; eye much too large, but not "goggle," because it is circular and quite closed by the stamens, so that probably it would hardly seed, lemon coloured; but it is a pretty thing.

*Trail's Mayflower.*—Like Oliver's Lovely Ann, from which it differs in the tint of colour and in the form of its pencillings. Pip medium sized, angular, nearly flat; edge apple green, impure, circular; colour plum, wholly in rays, of fair breadth; paste fair but not perfect; eye too broad, greenish yellow, bleaches; anthers projecting. Foliage thin in substance, much serrated.

*Yate's Morris's Green Hero.*—A late bloomer, with broad, smooth, deep green foliage that is apt to leave a considerable length of stalk naked. There should therefore be left a corresponding space between the surface of the soil and the rim of the pot at potting time. It is a coarse flower, and has never been a favourite, though few are more striking at first sight. Pip large, fairly rounded, flat; edge of the deepest and purest green, but suggesting the idea of a leaf rather than of a flower, much too broad; colour very dark maroon, only half its proper breadth, paste good; eye orange; medium trusser.

(To be continued.)

## ASPARAGUS CULTURE.

HAVING a few chapters to write on Asparagus culture, the matter may be taken in hand now, and the information can be stored for use at a convenient and seasonable time. Delicious, wholesome, and nutritious, Asparagus is the most esteemed of spring and early summer vegetables. It is a well-known cultivated, though not common British plant, its habitat being the sea coast and salty inland fens. Wherever found wild the soil is sandy, or a mixture of mud with sand, an infallible guide to its successful cultivation. However, many plants would be precluded were a strict adherence kept to those for which the soil is suited naturally, but by draining, tillage, and manuring, the soil, whatever it may be, is made capable of growing a variety of useful products. Therefore it is not so much a question as to what the soil is best adapted for, but rather what it can be made capable of producing by cultivation. Apportioning ground to the crops it is most suitable for, good as it is from a commercial point of view, is often, and we may say generally

inapplicable to plots of garden ground devoted to a supply of vegetables for home use. Very often so much is made of the requirements of certain plants as regards soil as to be a stumblingblock in the way of cultivation. Grant Asparagus to be naturally a seaside plant requiring a sandy soil, what is to hinder a sandy and saline soil being prepared for it inland? If the soil be wet—water lodging within 3 feet of the surface—it can be drained; if heavy, it can be made light and porous; if shallow, it can be deepened; and if poor it can be enriched. Any soil can be made to grow Asparagus.

**DRAINING.**—Asparagus being a seaside and fen plant, it may appear unnecessary and against the nature of the plant to drain the soil, but I have no doubt the native Asparagus lies considerably above low-water mark, and though it may be submerged by high water, the ground on which it grows is as long a time out of as under water, the soil being such as to allow the water to drain away freely. Land inundated by tide is very different from ground occasionally or periodically flooded by fresh water, and that is different from ground which has water stagnant in the subsoil. The tidal water is merely a thorough soaking with water twice a day through a sieve-like soil, and is consequently healthful, but the flood and lodging water is stagnating and decomposing—self-poisoning and corrupted. In one Asparagus luxuriates, whilst in the other it does not thrive; therefore it is not a bog plant in any sense, but a free open soil and air-loving plant, free to take in water, and equally free to part with superfluity. This is decided in cultural practice, at least I have never seen Asparagus worth the name in ground with water lodging within 3 feet of the surface. Warps or alluvial soils grow splendid Asparagus. They are liable to inundation, but it is only periodically or for a brief period, and when long continued it is most disastrous to Asparagus from the decay of the crowns, and where the water is stagnant the roots will not enter it, and those that descend into the soil in summer perish with the wet of winter. The soil for Asparagus should be well drained, and if inundation be practised provide means for its passage from the soil deeper than the Asparagus roots.

Soils vary, so must the drainage. There is sandy soil with a thin crust of ameliorated soil, due to decay of the natural vegetation or a long course of cultivation; the subsoil clay or marl, and above this water stagnant, the land giving a plentiful crop of Thistles and Horse-tails. At the depth of drains—viz., 3 to 4 feet, these soils are a quicksand, the drains soon fill unless preventive measures are taken when laying the drains. When the drains are cut a little of the finer parts of ditch brushing or straw should be scattered in the cutting, and the drain tiles, which should be 3 inch, laid upon it with a true fall and solid, and a little of the same placed over the tiles and pressed down. This will still the sand, and the drains will work for many years. I know some down over half a century as good as ever, only attend to the outlets. Being a good drawing soil the drains may be 27 feet apart. Other description of soil may be drained in the ordinary way, and so as to run off all water beyond the soil's retentive power within 3 feet of the surface.

**SOILS.**—These vary considerably, therefore a few observations on some of them may be given, and in preparing the ground for Asparagus we render it capable of supporting every description of vegetable crop, therefore permanently improved.

**Sandy Soil.**—It may be 3 feet or more deep—sand intermixed with loam, with a thin crust of ameliorated soil. Such can be trenched its full depth, but the trenching must be only stirring, not changing the surface soil for the underlying soil, for the top soil must not be put under a foot of poor sand, as would be the case were the soil trenched in the ordinary way, but in turning or loosening some of the top soil will be mixed with that lower down, and *vice versa*, which is an advantage both ways—i.e. the top will be the better of a little of the sand, and the bottom will be richer for the top soil. Any soil that can be had should be added and intermixed, and almost anything will do if only it will be free of the roots of coarse weeds. Likewise a thin soil over gravel—loosen it as deep as the ground soil admits, and the under strata to the extent of breaking up the pan. A good sandy loam with good soil, 18 inches to 2 feet deep, will only need trenching two spits deep, turning the top soil under, and loosening the soil at the bottom of the trenches to the depth of a foot or more, but not bringing it up, for at the surface we must have good soil, and no other to any great extent.

**Friable Loam.**—Beyond trenching as deeply as the good soil warrants nothing is required, and in dealing with these observe the same conditions in respect of loosening the bottom, and bringing up bad soil. Mix the soil as much as liked, but keep the top soil much as it was. Loams inclined to clay will be the better for an admixture of sea sand a 3 inch thickness being mixed with the top spit. In all soils for Asparagus the leaning should be to sand.

**Alluvial.**—In these we have what has been mud mixed with sand, &c. Some of the warps are almost devoid of sand, but they grow splendid Asparagus and Potatoes. If we go down we find sand or silt, and in trenching such bring some of it up and mix with the surface. If the under strata be unfavourable—and the less we have to do with clay the better—only break it up, applying a 3 or 6 inch layer of sand, and mix it with the top foot or 18 inches depth of soil. If the soil be fairly sandy, merely turn it over and it will grow anything.

**Clays.**—These are the worst of all for Asparagus. Perhaps there is only a spit or so of fairly ameliorated soil. The best thing possible is to burn some of the underlying stubborn soil, and spread it on the surface. Stir as deeply on the good soil, allow and loosen as deeply as convenient; but the "pan" must be broken. Failing burning bring on some road sidings, the rubbish from an old building—anything sandy or gritty, and

not bigger than a hen's egg, and use this chiefly for mixing with the loosened material beneath the good surface soil. Ashes also are serviceable.

There are other soils and peats, which only need treating like sandy soil—breaking up the pan, and bringing some of it, but not much, to the surface. Treated in the way indicated, most, if not all, soils will grow Asparagus. What, no manure! That is a first consideration with most persons, but we make it secondary. The soil must have its resources made available by stirring, so as to admit of its deriving the most benefit from the assimilating influences of the atmosphere, becoming a reservoir of warmth, air, and moisture—aliment presented in the form most available as food, and to which the roots of the Asparagus must have free access, so that what encourages the enriching of the soil accelerates the rooting of the Asparagus. With the soil freed of stagnant water, and deeply stirred, rain and air will enter it freely, we obtain a larger rooting area as well as an extended source of plant food. Instead, therefore of burying the manure in the bad soil, which is equally crude, supply it so that it will by access to air and rain be sooner converted into acceptable vegetable subsistence, and any excess be washed down and retained by the soil. In breaking up fresh ground, instead of putting the turf at the bottom of the trench, two spits from daylight only, turn it under so as to admit of the needful loose tilth for cropping, and to prevent trouble by the growth of the herbage, but the under strata must be disturbed all the same, and the deeper the better, so that the liberation of the food from the turf above may be distributed by the air and rain. The aliment should be brought to the plants, and not away from them, so as to cause the roots to descend in quest of it. Be the soil ever so poor it will be enriched by the dressings applied to the surface, but the surface is not enriched by that placed a foot or more from the top, except by what is brought up by worms. Get the soil well mixed and deeply stirred, and it will take any amount of manure to the best advantage to the crops.

If the ground be poor and thin apply a dressing of manure 6 inches thick, and mix it with the top spit; if in fair condition a 3 inch dressing will be sufficient. On a clay soil the refuse of the potting bench and rubbish heap mixed with the top 6 to 9 inches of the soil is capital, especially if it has been turned twice, and some salt added to it. Seaweed to the extent of a 6 inch thickness on light and peaty soil is attended with good results, and dead fish or fish refuse, such as obtains about fishing stations, is highly enriching to the soil, and is best formed into a compost with road scrapings and ashes for heavy soils, allowing it to be a few months before applying, but for light soil it must be dug in at once. Town manure is also an excellent dressing for heavy soil, alike on account of its enriching and mechanical action on the soil. The soil in all cases should be prepared in the winter some little time before being required for sowing or planting with Asparagus, and be forked over in dry weather before those operations, in order to effect a better incorporation of the manurial matter with the soil. Some may consider the preparation beyond their means. Manure is not available to anything like the extent advised, reliance having to be placed for the most part on artificials, and as they grow other vegetable crops fairly well why not Asparagus? Why not? Indeed, any soil of a light friable nature will grow Asparagus, only stir it and feed it at the surface, and adverse soils can be made available by utilising materials usually carted away as rubbish.—G. ABBEY.

(To be continued.)

#### WEST OF SCOTLAND PANSY SOCIETY'S SHOW.

The eighth annual Exhibition of Pansies, Roses, and Pinks was held in the Victoria Hall, Glasgow, on the 27th inst., under the auspices of this Society. The display of Pansies, notwithstanding the very dry season we have had this year, was very fine, the blooms for size, form, colour, and texture were all that could be desired. There was a very fine display of Roses and Pinks.

**PANSIES.**—Nurserymen only.—Twenty-four blooms show Pansies, distinct varieties. The first prize was awarded to Mr. A. Irvine, Tighna-bruaich, for very fine blooms of the following varieties:—D. Malcolm, p.s.; Miss McFarlane, w.g.; J. B. Robertson, y.g.; W. Duncan, d.s.; E. J. Martin, y.g.; Mrs. J. G. Paul, w.g.; W. Dickson, y.g.; Rev. J. Morrison, p.s.; M. E. Sutherland, w.g.; Gomer, y.s.; Mauve Queen, d.s.; Victoria Gem, w.g.; Sir W. Collins, y.g.; Mrs. J. P. B. Robertson, w.s.; W. Robin, y.g.; Annie Dowie, w.s.; D. Dalglish, y.g.; Harry Paul, d.s.; Mrs. Anderson, w.g.; Maggie Thomson, y.s.; and four seedlings. Mr. A. Lister, Rothesay, was second, and Mr. J. Sutherland, Lenzie, third.

Twenty-four blooms, fancy Pansies, distinct varieties.—Mr. A. Lister, Rothesay, was first with a splendid stand of blooms, comprising Pilrig, A. Buchanan, E. Bruce, Lord Rosebery, Endymion, Mr. G. P. Frame, Catherine Agnes, Miss Browell, Miss J. Orkney, N. McKay, G. Cromb, Aye Ready, J. Bryce, and J. Lamont, Isa Alexander, D. McBean, J. Battensby, Princess Beatrice, Craigforth, Arthur Stewart, Mrs. Wm. Dalglish, Mrs. Fulton, and two seedlings. Mr. J. Sutherland, Lenzie, was second; Mr. A. Irvine, third.

**Gardeners' Class.**—The prizetakers in this class were:—Twelve blooms, show Pansies, distinct varieties.—First, Mr. J. Harper, Dregghorn; second, Mr. J. Tinsley, Lennox Castle; and third, Mr. R. Miller, Netherhill. Twelve blooms, fancy Pansies, distinct varieties.—First, J. Tinsley; second, R. Stewart; third, R. Miller.

In the amateurs' class, Messrs. P. Lyle, Kilbarchan; D. Russell, Calder; Wm. Smellie, Neuton Mearns; and W. Buchanan, Balmore, were the principal prizetakers.

In the gardeners' and amateurs' class, Messrs. J. Harper, P. Lyle, W. Storrie (Lenzie), and J. Harper were the successful competitors.

Open to all, twenty-four blooms show Pansies, distinct varieties. Mr.

P. Lyle gained the first prize in this class with a very fine stand of blooms, which were—Pilrig Gem, d.s.; Miss E. D. McLaren, p.s.; Mrs. J. Bolton, w.g.; Mrs. Gladstone, w.s.; Pilrig Model; Mrs. Galloway, w.s.; Countess, w.g.; J. Bolton, y.g.; A. Miller, d.s.; Royal Visit, w.g.; seedling; Miss Barr, w.g.; Gomer, y.g.; Mauve Queen, d.s.; J. Smith, y.s.; Miss Buchanan, w.s.; Captain Crombie, d.s.; Lizzie Bullock, y.s. seedling; W. Crockett, y.s. seedling; Arch Rolland, y.s.; Mrs. Fife. Second, Mr. W. London; third, Mr. G. Harper.

Twenty-four blooms, fancy Pansies, distinct varieties. The first prize was won by Mr. A. Lister, the blooms were—E. Bruce, A. Buchanan, J. G. Paul, Lord Rosebery, J. Bryce, John Gibson, Catherine Agnes, Wm. Dick, Chas. Stamsell, John Shaw, Mrs. Goodwin, J. Lamont, Pilrig, Janet Orkney, Sweet Jessie, P. Beatrice, T. Bell, Miss Dalglish, Mrs. Sutherland, Aye Ready, Miss E. Lawson, Neil McKay, Craigforth, and Mrs. Howard; second, Mr. A. Dalziel; and third, Mr. R. Stewart. Mr. D. Russell was awarded the prize for the best bloom of a show Pansy in Hall, of the variety W. Fulton, d.s. Mr. M. Campbell, High Blantyre, had the best fancy Pansy; it was a seedling named Mrs. J. Ellis, which was submitted to the Judges for their opinion, and they granted it a first-class certificate; its colour is deep blue, edged with white. In the seedling class for show and fancy Pansies, the prizetakers were Messrs. A. Irvine, R. Stewart, J. Milne, S. Russell, and R. Edmondstone.

In the local class, two miles from Glasgow Royal Exchange, Messrs. J. Astie, Albert Gardens, J. McCrossan, and Allan Ashcroft were the prizetakers in the Pansies. For six bunches Violas J. Campbell was first, W. McLaren second.

**VIOLAS** (open to all).—Twelve bunches Violas, distinct varieties.—Mr. J. Baxter, Daldowie Broomhouse, again carried all before him. The varieties he exhibited and gained first prize with were Countess of Hopetown, Ebor, Blue Cloud, Goldfinch, York and Lancaster, Mina Baxter, Countess of Kintore, Bullion, Morning Star, A. Grant, Lucy Ashton, Mrs. Cobham; second Mr. A. Lister, third Mr. George Bainbridge. Six bunches Violas, distinct varieties.—First Mr. J. Baxter, second Mr. J. Stewart, third Mr. A. Lister. Six bunches seedling Violas, three blooms of each.—First Mr. J. Baxter. Best self Viola selected from the above.—First Mr. J. Baxter. Best Fancy Viola selected from above.—Mr. J. Baxter.

In the ladies' competition for best arranged epergne filled with Pansies, Violas, Roses, Pinks, and Ferns, Mrs. W. B. McNeil, Woodlands Road, was successful. Best bouquet of Pansies.—First Mrs. J. G. Paul, Paisley; second Jane P. Stewart, Lenzie; third Edith Sutherland, Lenzie. Best bouquet of Violas.—First Jane P. Stewart; second E. Sutherland; third Mrs. Raeside, Yorkhill. Best basket of cut flowers and Ferns.—First Mrs. McNeil; second Mrs. Paul; third, E. Sutherland.

**Pansies.**—Special prizes open to gardeners and amateurs. Twelve blooms Fancy Pansies.—First, Mr. W. Loudon, second Mr. W. Storrie, third Mr. D. Russell. Twelve blooms Show Pansies.—First Mr. J. Harper, second D. Russell, third A. Wilkie.

**Roses.**—These formed a very fair show, but they were not quite up to former years. The blooms on some of the stands were small. In the nurserymen's class for forty-eight blooms, distinct varieties, Messrs. J. Cocker and Sons, Aberdeen, were first with a very fine stand. The names of the varieties were Mary Pochin, Her Majesty, Alfred Colomb, A. K. Williams, Mons. Noman, Duke of Wellington, Alphonse Soupert, White Baroness, Horace Vernet, John Stuart Mill, Pride of Waltham, Queen of Queens, Annie Wood, Comte Raimbaud, Senateur Vaisse, Duke of Albany, Duc de Rohan, Charles Wood, La France, Antoine Ducher, Marie Baumann, Mdle. Eugenie Verdier, Francois Levet, Lælia, Merveille de Lyon, Madame Eugenie Verdier, Charles Lefebvre, Baron Nathaniel de Rothschild, Marguerite de St. Amand, Madame Hippolyte Jamain, Duchess of Bedford, Earl of Pembroke, Marquise de Castellane, Mons. E. Y. Teas, H i rich Schultheis, Eie Morel, Baroness Rothschild, Francois Michelon, Marie Rady, La Duchesse de Morny, Marie Lonis Pernet, Sir Garnet Wolseley, Madame Gabriel Luiz t, Ulrich Brunner, Comtesse de Serenye, La Duchesse de Morny, and Marie Van Hontte. Second Messrs. A. Dickson and Sons, Newtonards, Ireland; third, Mr. David Robertson, Helensburgh; fourth, Mr. S. McGredy, Portadown. Twenty-four blooms Roses, distinct varieties, Messrs. A. Dickson & Sons were first in this class with Her Majesty, Madame E. Verdier, very fine (this was awarded the prize as being the best bloom in the hall); Alfred Colomb, Madame Nachury, Madame Isaac Periere, Wm. Keile, La France, Earl of Dufferin, Captain Christy, Madame V. Verdier, Etienne Levet, Marguerite de St. Amand, Madame Christine Nilsson, Ulrich Brunner, A. K. Williams, Comtesse de Serenye, Souvenir de Spa, Chas. Lefebvre, Lady Sheffield, Lady Helen Stewart, Sophie Coquerel, Horace Vernet, Madame Finger. James Cocker and Sons second; William Montgomery, Cardross, third. In the gardeners' class Mr. Wm. Parlange, Row, was the principal prizetaker. Open to amateurs only.—Messrs. T. McCrorie, Kilbarchan, J. Kidd, Rothesay, P. McFarquhar, Row, were very successful in this class. Twenty-four blooms, York and Lancaster Roses.—First, Mr. J. Baxter; second, Mr. W. Thorburn; third, Mr. W. Buchanan.

**PINKS** (nurserymen only).—Twenty-four blooms Pinks, distinct varieties.—First J. Cocker & Sons. The varieties were Prince of Wales, John Pattison, Emerald, Olga, Dr. Clark, Boiard, Ne Plus Ultra, Firefly, Wm. Paul, Kate, Empress of India, Clothilda, Brightness, Nellie, Device, Royal Standard, seedling, seedling, Fireman, Wm. Bruce, John Ball, Scarlet Gem, Lena, Harry Hooper; second M. Campbell; third W. Paul and Son. In the gardeners' and amateurs' classes Messrs. W. Storrie, A. Gilchrist, T. McCrorie, and J. Muir, were the principal prizetakers. Open to all.—Twelve blooms, Pinks, varieties.—First J. Cocker & Sons; second William Storrie. Best Pink in the Hall, J. Cocker & Sons. The bloom was "Boiard." The Jubilee prize for Pinks (twenty-four blooms, laced, distinct varieties) was gained by J. Cocker & Sons with a very fine stand of blooms. The varieties on this stand were Boiard, Brightness, Ne Plus Ultra, Emerald, Prince of Wales, W. Paul, seedling, Fireman, Lena, Olga, Attraction, Dr. Clark, D. Saunders, Harry Hooper, seedling, James Minty, Royal Standard, R. H. McShie, Elsie, Emily, John Ball, Godefroy, Com t, Gwendoline; second Messrs. W. Paul & Sons; third Mr. M. Campbell.

Twelve table plants, varieties.—First Mr. J. Sutherland; second Mr. At Raeside; third Mr. J. McCrae, Whiteinch. Twelve coat flowers.—First

Mr. Hugh Miller, Busby; second Mr. W. B. McNeil; third Mr. W. Thorburn. Hand bouquet.—First Mr. W. B. McNeil; second Mr. H. Miller; third Mr. J. Sutherland. Hand bouquet of Roses.—First Mr. W. B. McNeil; second Messrs. A. Pattison & Son; third A. Raeside. Six Exotic Ferns, varieties.—First Mr. A. Raeside; second Mr. J. Campbell. Six British Ferns, varieties.—First Mr. M. Campbell; second Mr. J. Campbell. Six Verbenas, distinct varieties, three trusses each.—First Mr. M. Campbell; second Mr. John Shaw; third Mr. W. Thorburn. Six table plants.—First Mr. G. C. Gordon, second Mr. H. Dixon.

Open to gardeners and amateurs.—Twelve bunches hardy herbaceous border flowers, distinct varieties. The competition in this class was very keen, and the display was fine. The first prize was awarded to J. Tinsley, Lennox Castle, his was made up as follows:—*Campanula coronata*, *Alstromeria grandiflora*, *Gaillardia Admiration* (this was very fine), *Coreopsis lanceolata*, *Linaria Peloria*, *Spirea venusta*, *Erigeron speciosum*, *Anchusa italica*, *Lychnis dioica alba pl.*, and *Aquilegia chrysantha*; second, Mr. J. Stewart; third, Mr. John Meiklem; fourth, Mr. W. Storie. Six bunches hardy herbaceous border flowers.—First, Mr. J. Stewart; second, Mr. A. Adam, Lennoxtown; third, Mr. W. Mason, Bridge of Allan. Mr. Stewart's six bunches were *Campanula coronata*, *Lobelia*, *Gaillardia*, *Coreopsis lanceolata*, *Anchusa italica*, and *Lychnis dioica alba fl. pl.* Six spikes *Phloxes*.—First, Mr. W. Mason; second, Mr. J. Meiklem; third, Mr. W. Thorburn. The Jubilee prize for the best six bunches of hardy herbaceous border flowers, distinct varieties, was won by Mr. J. Tinsley, Lennox Castle, with *Campanula coronata*, *Alstromeria grandiflora*, *Francoa appendiculata*, *Gaillardia Admiration*, *Coreopsis lanceolata*, and *Lychnis dioica alba pl.*

MISCELLANEOUS EXHIBITS.—Mr. M. Campbell, nurseryman, Blantyre, exhibited a splendid collection of Carnations in pots, Begonias, and Verbenas. Among the Begonias the following were fine—Ball of Fire, Pimrose Queen, Annie Laing, Lothair; Verbenas, Ruby, Sunbeam, Lustrous, Lady Brooke. Mr. Campbell also had stands of Fancy Pansies, French Marigolds, Roses, Carnations, and Picotees, which were all well set up. Mr. G. Bainbridge, Eglinton Street, had a very good table of Pelargoniums, pot and cut flowers, also of Ivy-leaved Pelargoniums in flower. The front part of his table was occupied with stands of Pansies, and some very pretty ladies' bouquets. Messrs. Dobbie & Co., Rothesay, had a fine lot of African Marigolds, Pansies, &c. Mr. M. Cuthbertson, Rothesay, exhibited a fine table of Marigolds, Pansies, and florists' flowers. Mr. A. Lister, Rothesay, had some fine Carnations, Picotees, and Pansies. First-class certificates were awarded to the following:—Mr. M. Campbell, Blantyre, for Pansy Mrs. Ellis and for Pansy Miss French; to Mr. A. Lister, Rothesay, for Fancy Pansy J. G. Paul; to Messrs. J. Pattison & Son, Paisley, for Fancy Pansy H. M. Stanley; to Mr. M. Cuthbertson, Rothesay, for *Gaillardia M. Smith*; to Mr. J. Baxter, Broomhouse, one for *Viola J. In Burns*, one for *Viola Miss Burns*, one for *Viola Lucy Ashton*.—ALBERT, Glasgow.

### SUMMER-FLOWERING HEATHS.

IN reply to a correspondent, "G. S. P.," who desires a descriptive list of summer-flowering Heaths, we print the following article by an experienced cultivator who has had a large collection under his charge.

ERICAS are now forming bushy heads, for, although generally looked upon as slow-growing plants, they rapidly assume handsome proportions after about the third year. It will be well to set the plants in the open air now—that is, if they are not already removed from frames or pits, as by this system the growths become thoroughly hardened and vigorous. Care must be taken to water only during early morning or towards evening, as continual watering during the heat of the midday sun is sure to result in death to the plants, and yet we have seen this practice persevered in by men who consider themselves skilful plant growers. When water is given let it be in such quantities that the whole ball of earth becomes saturated, for partial watering, we are assured by practice, is a fertile source of mildew. Again, do not place Heaths under the shade of trees; they do not require it, and often become injured by drip during a few days' continued rain, and their growth only becomes partially ripened. Soft or rain water should be used for watering these plants. If during drought this is not procurable the water to be used in the evening should stand fully exposed to the sun during the whole day. Some recommend the use of weak liquid manure for Ericas, and we have seen it applied beneficially to plants that are not wanted after the blooming season; but it should never be given if the plants are intended to live a number of years. The following will be found a good selection for effect.

*Erica ferruginea superba*.—Leaves arranged in fours, linear obtuse, densely clothed on the edges with long, woolly, rusty hairs. Flowers in spreading whorls from the ends of the principal branches, cylindrical, with a swollen base and contracted mouth; limb rather small, spreading; colour light pink at the base, passing upwards into a reddish purple.

*E. Shannoniana* (fig. 10).—This is a superb large-flowering species, bold in growth, and much branched. Leaves arranged in threes, ascending, three-sided, and acuminate. Flowers produced in large terminal whorls; these are flask-shaped, delicate pink or flesh colour, saving at the contraction of the neck, where the colour is more intense; footstalks and calyx deep red; whole flower glutinous.

*E. hyacinthoides*.—A dwarf-growing, neat, and handsome species, now unfortunately very rare. The last time we saw it was in the gardens of Harrenhausen in Hanover, where so many of these beautiful old species were treasured by the elder Wendland. It scarcely reaches 12 inches in height, much branched, and densely furnished with stout, smooth, and shining dark green linear obtuse leaves. Flowers large and freely produced from the ends of nearly all the branches. They are arranged in fours, flask-shaped, the segments being large and spreading, whilst the colour is a beautiful soft rose throughout.

*E. infundibuliformis*.—A slender-growing beautiful plant. Leaves linear obtuse, smooth, arranged in threes, and light green. Flowers erect, long, and slender, produced in fours upon short footstalks; tubes deep red, the broad spreading limb being white.

*E. verticillata*.—This is an elegant and extremely useful plant for all purposes; it is erect in growth. Leaves arranged in fours, linear acute, destitute of hairs, and dark green. Flowers produced in large pendant whorls towards the ends of the branches; they are about an inch long, cylindrical, somewhat square at the base, and brilliant orange red in colour.

*E. jasminiflora*.—Although somewhat straggling in habit this is, nevertheless, a very desirable species. The leaves are mostly arranged in threes, triangular, spreading, and dark green. Flowers mostly in threes from the ends of the simple branches, about 1½ inch long, cylindrical, with a swollen base, and a large, flat, spreading limb, the segments of which are cordate; tube rosy pink, the segments pure white.

*E. incarnata*.—A species now very seldom seen in collections, yet it is a small and compact grower, and very gay when in flower. It forms a dense much-branched plant some 12 or 18 inches high, the leaves



Fig. 10.—*Erica Shannoniana*.

being linear obtuse, quite smooth, arranged in fours and bright green. The flowers are produced in dense bunches upon the ends of all the branches, they are ovate with a contracted mouth; colour bright reddish pink.

*E. vestita alba*.—A rather tall-growing variety. Branches ascending. Leaves about an inch long, crowded, linear, arranged in sixes, and dark green. Flowers produced in large whorls near the ends of the branches, sometimes in double tiers. Flowers longer than the leaves, pure white, slightly downy.

*E. vestita lutea*.—Similar in habit to the preceding, but the leaves are more robust. Flowers produced in large and dense whorls; they are club-shaped, upwards of an inch long, slightly ribbed, and clear sulphur yellow in colour.

*E. vestita fulgida*.—A very highly coloured variety of robust growth. Branches erect. Leaves long arranged in sixes, linear, smooth, and dark green. Flowers crowded near the apex of the principal shoots, upwards of an inch long, and rich bright red.

*E. vestita incarnata*.—This is scarcely such a strong-growing variety as the preceding. Leaves six to eight in a whorl, linear, erect, and very deep green. Flowers produced many together in crowded whorls near the apex of the main shoots; they are club-shaped; about an inch long; ground colour white suffused towards the apex with bright rose or flesh colour, rendering it a very charming plant.

*E. vestita rosea*.—Erect in growth, with simple branches and dark green leaves, which are linear obtuse, arranged in eights, and shorter than either of those varieties named above. Flowers crowded, an inch in length, and rich deep rosy colour.

*E. vestita carnea*.—A truly beautiful variety. Habit of growth erect as in other kinds. Leaves linear, erect, slender, and pale green in colour.



Flowers produced in crowded whorls towards the upper part of the branches, about an inch in length, and of a delicate flesh colour.

*E. Irbyana*.—The improved form of this species is a most desirable variety. It produces long, simple, erect branches. Leaves somewhat triangular, armed at the point with a stiff bristle, the edges slightly toothed; colour deep green. Flowers in large spreading umbels, upon long footstalks from the ends of the branches; they are upwards of an inch long, much swollen at the base, very sticky; the segments heart-shaped and spreading, white, tinged with flesh colour at the base.

*E. Lindleyana*.—Leaves arranged mostly in fours, linear oblong, mucronate, ciliate on the edges, deep green with a central white stripe on the back of each leaf; whorls large and terminal, tubular, deep crimson passing into white; the throat and limb vivid green.

*E. Jubana*.—A beautiful free-flowering plant, and of compact habit. Leaves in threes, flat on the upper side, keeled below, and dark green. Flowers produced upon very long, erect, red footstalks, in large umbels; they are much swollen at the base, with a contracted mouth and large spreading limb; the latter is white, while the tube is reddish purple.

*E. droseroides*.—An elegant species now but too seldom seen. It is a dwarf much-branched plant. Leaves alternate, linear obtuse, with recurved points, the edges densely furnished with glandular hairs. Flowers



Fig. 11.—*Erica ampullacea*.

produced in large whorls upon the ends of the branches. These are reddish purple in colour, much swollen at the base, with a contracted neck; segments somewhat small, spreading, and deep red; whole flower glutinous.

*E. nitida*.—A free-growing densely branched plant of great beauty. Leaves in threes, short, linear obtuse, and deep green. Flowers somewhat ovate, terminal on all the small branches, in umbels of three to five, forming spikes 9 to 12 inches long; footstalks, calyx, and the whole of the flower beautiful snow white.

*E. Cocentryana*.—This is a compact, low-growing, and much-branched plant. Leaves in fours, linear obtuse, bright green. Flowers stemless, and set in large clusters among the foliage on the ends of the branches; the tube is bright red, the spreading segments of the limb pure white.

*E. ampullacea* (fig 11).—Our figure represents the typical plant, which is very beautiful; the ground colour is white or pale flesh striped throughout with deep rose, the contracted neck being deep purple. There are three varieties—viz., *ampullacea elegans*, *ampullacea obbata*, and *ampullacea rubra*, all of which either in colour or size are great improvements on the type.

*E. metulæflora superba*.—This improved form of the species is much easier to grow than the normal form through not being so liable to mildew. Leaves in fours, linear obtuse, slightly hairy on the edges. Flowers in terminal whorls, wholly deep reddish crimson, saving the circle round the throat, which is deep purple.

*E. tricolor profusa*.—A superb variety. It is very compact in habit, and an abundant bloomer. Leaves arranged in fours, linear obtuse, mucronate, and densely fringed with long hairs at the edges; colour

deep green. Flowers terminate the branches, produced in whorls of great size; they are large and tubular, with a swollen base, colour deep rich rosy carmine passing into white, the contracted neck being encircled with green, whilst the tips of the segments are white.

*E. Fairricana*.—A slender branching species of great beauty. Leaves arranged in fours, linear, mucronate, and fringed with short hairs at the edges, green above, with a central pale band on the under side. Flowers large, in terminal whorls of from eight to twelve, much swollen at the base, where the colour is rosy carmine, passing upwards into pink, the contracted neck deep crimson; limb reflexed, pinkish white.

*F. insignis*.—A bold-growing species and a profuse bloomer. Leaves arranged in fives, oblong obtuse, fringed with hairs on the edges and pale green. Flowers in large terminal whorls, somewhat short, but stout; colour dark rosy carmine at the base, contracted throat, dark purple; segments of the limb white.—T.

## HORTICULTURAL SHOWS.

ESHER.

THE second annual Exhibition of this flourishing Society was held in the charming grounds of Moore Place, Esher, kindly lent for the occasion by the President, Sir Wilford Brett, K.C.M.G., on Thursday, July 28th. Classes were provided for plants in pots, groups, cut flowers, vegetables, and fruit, a division being also reserved for cottagers, whom it is a prime object of the Society to encourage in gardening pursuits. The Show was held in a series of marquees, and may be described as a very successful one, there being plenty of competition, and some exhibits of more than average excellence. The vegetables which won the principal prizes for Mr. C. J. Waite were deserving of special reference. He showed two collections of ten and twelve kinds, all in splendid condition, the Onions, Carrots, Tomatoes, and Peas being particularly good, besides winning four other first prizes—a capital record. The groups were highly effective, and were of very equal merit, Mr. Cawte gaining a narrow victory in the principal class. Particulars of the principal awards are appended:—

There were two entries for Class 1, four stove and greenhouse plants, Mr. R. Cawte, gardener to J. P. Robinson, Esq., being first with good specimens of *Vinca rosea*, *Allamanda Hendersoni*, *Plumbago capensis*, and *Bougainvillea glabra*; and Mr. J. Child, gardener to Mrs. Slade, The Firs, Claygate, second. For two stove and greenhouse plants, Mr. J. Smith, gardener to E. Grey, Esq., Fair Mile, won somewhat easily, having a grand plant of *Hydrangea hortensis*, and a fair specimen of *Eucharis amazonica*. Mr. G. Holden, gardener to Mrs. Izod, was second. For six stove and greenhouse foliage plants, Mr. Cawte was again first, having good specimens of *Cycas revoluta*, *Areca lutescens*, and *Pandanus Veitchii*, and a very fine plant of *Davallia Mooreana* in his group. Mr. J. Smith was second, showing a fine healthy specimen of *Maranta zebrina*; and Mr. W. Sutton, The Gardens, Ashby Park, was third. In a corresponding class for three plants, Mr. C. J. Waite, gardener to Col. Hon. W. P. Talbot, Esher, was awarded the first prize, and was the only exhibitor. Begonias were well shown by Mr. J. Thorne, gardener to A. E. Flood, Esq., The Bush, Walton-on-Thames, who secured the first prize with six healthy well flowered plants in the class for that number. He was followed by Mr. J. Harvey, gardener to Capt. Terry, Hershams, who also showed well, and Mr. Child. Mr. Waite won with three plants, Mr. Holden being second, and Mr. Carpenter, gardener to — Abbott, Esq., Walton-on-Thames, third. Mr. Cawte followed up his previous successes by securing the premier award for six exotic Ferns; he had *Asplenium nidus* in very fine condition, with noteworthy specimens of *Adiantum farleyense* and *Davallia Mooreana*. Mr. J. Smith was second, *Microlepia hirta cristata* being well shown. Messrs. Waite, Holden, and Carpenter took the prizes for three plants. With six Zonal Pelargoniums, Mr. Frith, gardener to F. Bottrell, Esq., secured a meritorious victory, Mr. C. Gardner being second, and Mr. Child third. Mr. Holden received the chief award for three plants, Mr. Palmer, gardener to Hume Dick, Esq., being second. Fuchsias were well shown by Mr. Child and Mr. Holden, who took the first prizes in the two classes, Messrs. Waite, Smith, and Carpenter following. Mr. Waite was first for six Coleuses, Mr. Palmer being second, Messrs. Holden and Carpenter taking the prizes in the smaller class. Table plants were best shown by Mr. C. J. Waite, but the struggle was a very keen one between him and Mr. Holden. Mr. Sutton was third, five lots being shown. In the smaller class the prizes went to Messrs. Palmer, Carpenter, and Thorne. Mr. J. Thorne won with six Gloxinias, showing some beautifully flowered plants, Mr. Holden being a good second.

The groups of plants were, as before noted, excellent. Two classes were provided, Mr. Cawte winning for a semi-circular group, 14 feet by 7 feet. Lilioms, Gladioli, Gloxinias, and Begonias provided the colour, rising from a groundwork of Ferns, and interspersed with fine-foliaged plants. Mr. Sutton was a capital second. For a smaller group (10 feet by 5 feet), Mr. Holden was first, Mr. Waite second, and Mr. Carpenter third, Mr. C. Gardner being highly commended. These were all charming groups and reflected the greatest credit on the exhibitors.

Three prizes were offered for a collection of ten dishes of vegetables, distinct kinds, and the three stands were all of great excellence. Mr. C. J. Waite, who has scored so many victories with vegetables of late, was first, exhibiting White Leviathan Onion, 16 inches in circumference, Sutton's King of Cauliflowers, Egyptian Turnip-rooted Beet, Ne Plus Ultra Beans, Sutton's new Intermediate Carrot, Sutton's new Marrow, Reading Perfection Tomato, Duke of Albany Peas, and Artichokes. Mr. Cawte was a good second, showing Onions and Beet well, and Mr. Palmer was third. Messrs. F. Hopkins, gardener to J. Wodderspoon, Esq., The Chestnuts, Walton-on-Thames, first; Frith, second; and Turner, gardener to — Francis, Esq., third, took the prizes for five dishes. Mr. Hopkins was again first with a brace of Cucumbers, exhibiting a nice brace of Carter's Model. Mr. Waite followed with Tender and True. For fifty pods of Peas Mr. Palmer won with a fine dish of Duke of Albany, Mr. Hopkins following with Sutton's Royal Jubilee. For a similar number of Scarlet Runners or Dwarf French Beans Mr. Waite was an easy first with a very fine dish of

Runners, Mr. Palmer following with a good dish of Canadian Wonder Dwarf French. For twelve Onions, one variety, there was a close fight between Messrs. Waite and Palmer; the former winning with a fine lot of White Leviathan, and Mr. Palmer staging Brown Globe. There were three other dishes. Mr. Cawte received the chief award for nine Carrots, staging the Intermediate; Mr. Waite following closely with Sutton's Intermediate. For six dishes Mr. Waite won with Fiddler's Prolific, Prizetaker, Sutton's Seedling, Vicar of Laleham, Imperator, and Snowdrop; Mr. Cawte was second, and Mr. Palmer third. Mr. Waite also won with twelve Tomatoes, showing Reading Perfection in splendid condition; Mr. Cawte following closely, Mr. Thorne being third. A special prize of two guineas was offered by the Native Guano Company for a collection of twelve vegetables grown with the Company's manure. Mr. Waite was the only exhibitor, and received the prize for a magnificent lot, amongst the best seen this year.

There was not much competition in the fruit classes, but some creditable examples were staged. For a collection of six dishes, Pines excluded, Mr. Waite scored a meritorious victory, showing Ryton Muscat and Madresfield Court Grapes, Elton Pine Strawberries, Grosse Mignonne Peaches, Stanwick Elruge Nectarine, and a seedling Melon; Mr. Sutton was second, and Mr. Gardner third. For three dishes Mr. Palmer was first, Mr. Turner second, and Mr. Carpenter third. Mr. G. Carpenter was first with one Melon, and Mr. Cawte second. For two bunches of black Grapes Mr. Waite was first with Madresfield Court, medium-sized bunches carrying a nice bloom, Mr. Hopkins following with Black Hamburg. For two bunches of white Grapes Mr. Hopkins won with capital examples of Foster's Seedling, Mr. Waite being second with Ryton Muscat. For six Peaches Mr. Palmer won with Dymond, Mr. Sutton being second with Royal George. For six Nectarines Mr. Waite won with Stanwick Elruge, Mr. Gardner being second with Lord Napier. Cut Roses, hand bouquets, and vases were fairly shown, and lent variety to the fruit tent.

The miscellaneous exhibits comprised an attractive mixed group from Messrs. John Laing & Co., Forest Hill, including Begonias in variety, Lilioms, a variety of Orchids, fine-foliage plants, and a box of cut Roses. Another charming group was arranged by Mr. Foster, nurseryman, West End, Esher. The Show was well attended. Mr. Crump was an able and courteous secretary.

#### LIVERPOOL.—JULY 30TH AND AUGUST 1ST.

The eighth summer Show of the Liverpool Horticultural Society opened in Sefton Park on Saturday last, and was in every respect of the most meritorious description. In consequence of the sale of the collection of the late Mr. Neuman some fear was at one time entertained that the absence of the magnificent specimen plants with which Mr. W. Mease won so many honours that the Show would not equal its predecessors; but although his plants were missed there was no hank in the large tent; on the contrary, the competition was greater than usual, and the aggregate display was unquestionably one of the best of the year. Fruit was admirably represented, many of the Grapes being of remarkable excellence; vegetables surpassed those staged at any of the Association's previous exhibitions; hardy herbaceous flowers were, if possible, better than ever, while Roses, considering the season and the date of the Show, were staged in surprising numbers and of generally good quality, so that altogether it is doubtful if the Exhibition has been surpassed by that of any other that has been held during the present season in any part of the kingdom, and the Committee of the Association and exhibitors are to be congratulated accordingly.

**SPECIMEN PLANTS.**—In the class for twelve stove and greenhouse plants the premier position was well won by Mr. C. Roberts, gardener to A. Nicholson, Esq., Highfield Hall, Staffordshire, with *Kentia australis* and *Cycas circinalis*, both magnificent; *Thrinax elegans*, *Croton angustifolius*, very fine; *Cycas revoluta*, and a splendid example of *Croton Baroness James de Rothschild* as foliage plants; the flowering specimens consisting of *Erica jasminiflora alba*, two *Dipladenias*, two *Ixoras*, and a *Clerodendron*, these ranging from 4 to 5 feet in diameter, all fresh, healthy, and well flowered. Mr. James Cypher of Cheltenham was second with plants that would have won the chief prize at most of the shows of the year, third honours being awarded to Mr. A. R. Cox, gardener to W. H. Watts, Esq., Elm Hall, Wavertree. This collection included one of the brightest and most elegant plants of *Croton aigburthensis* ever seen—like a fountain of gold; a splendid specimen of *Ixora coccinea* (to which a prize as the best flowering stove plant in the Show was awarded), and a wonderfully fine *Allamanda*, *Calamus ciliaris*, and a *Latania* representing first-rate culture, also attracted attention by their excellence.

In the local class for eight stove and greenhouse plants Mr. B. Cromwell, gardener to T. S. Timmis, Esq., Cloveley, Allerton, nobly won the first prize; *Croton Queen Victoria* in this collection also being awarded the prize as the best fine-foliaged plant in the Show, it being 8 feet by 8 feet, and in superb condition. *Croton Disraeli* was 6 feet in diameter, an *Ixora* and an *Allamanda* approaching the same size. Mr. A. Crosbie, gardener to B. Hall, Esq., Dudlow House, Wavertree, was second with fresh fine healthy specimens, *Kalosanthes coccinea*, brilliant. In the class for eight fine-foliaged plants Mr. J. Jellico, gardener to F. H. Gossage, Esq., Camp Hill, Woolton, secured the premier position with large well-furnished richly-coloured examples, *Croton Queen Victoria* and *Pritchardia pacifica* being conspicuous by their excellence; Mr. Cypher was second, and Mr. Crosbie third, with grand specimens. In the class for four stove and greenhouse plants Mr. A. R. Cox was first with very creditable examples of *Ixora regina* and *I. coccinea superba*, *Erica Eweriana superba*, and an *Allamanda*, all good.

The first prize for six fine foliaged plants was well won by Mr. Cromwell, *Gleichenia dichotoma* 6 feet across being the leading specimen; Mr. A. R. Cox was second, and Mr. T. Foster, gardener to J. Brancker, Esq., Wavertree, third. Mr. Cypher was first with six flowering specimens, *Erica Dennisoniana*, *Croton regina* and *Fraseri*, a *Clerodendron*, *Stalice*, and *Allamanda*; second Mr. C. Roberts, with highly creditable specimens.

In the class for single specimen greenhouse plants Mr. Evans secured the chief prize with a splendidly grown example of *Bouvardia Alfred Neuner*, 4 feet across, half globular, with deep green foliage, and innumerable trusses of flowers. We failed to observe the second prize plant. Mr. T. Gowan, gardener to J. Cunningham, Esq., Linton Lodge, Mossley Hill, was third with a *Kalosanthes* 4 feet in diameter. In the class for single stove plants in flower Mr. Roberts was placed first with *Dipladenia amabilis*,

very fine; second Mr. A. Lewis, gardener to L. F. Bahr, Esq., with a very fine *Eucharis*; third Mr. P. Barber, gardener to Milnes Barnsby, Esq., St. Michael's, with *Oncidium flexuosum*.

**GROUPS.**—These call for no special notice, for they were considerably behind the average of previous years; in fact, the only neat, well-arranged group was contributed in the open class by Messrs. R. P. Ker & Sons, Aigburth Nursery; the *Crotons* used were all new varieties and particularly striking for their colour. In the amateurs' class, Mr. J. Jellico was first; Mr. A. R. Cox, second; Mr. T. Jones, gardener to W. C. Clark, Esq., Sefton Park, third; an extra being given to Mr. F. Francis, Greenbank, Wavertree.

**ORCHIDS.**—These were not numerous, but the examples staged were in excellent condition. For four plants Mr. Cypher was deservedly placed first with a well-flowered plant of *Epidendrum vitellinum majus*, *Cattleya Gaskelliana* with twenty-one flowers, *Saccolabium Blumei majus* with three fine spikes, and *Cypripedium barbatum superbum*, well flowered and about 2 feet through; Mr. J. Edwards, gardener to H. Tate, Esq., The Beeches, Allerton, second; and Mr. W. Moss, gardener to W. Holland, Esq., Mossley Hill, third. For one plant, Mr. J. Hurst was second, and Mr. W. Moss third, no name having been placed on the first prize plant.

**DRACENAS.**—The competition for the timepiece (value five guineas) offered by Messrs. W. Cottrell & Co., horticultural builders, 152, Canning Street, Liverpool, for eight *Dracenas* in 6-inch pots was very keen. Mr. John Snow, gardener to J. Bruce, Esq., Wadhurst, Sussex, was successful with well-grown plants of *Goldieana*, *Lindeni*, *Madame Heine*, *Berkleyi*, *Renardiae*, *Gladstonei*, and *Madame F. Bergman*.

**TABLE PLANTS.**—These were exceptionally good, being of a small neat size; in fact, they could not have been in better condition, for every collection staged was highly creditable to the exhibitor. For six plants, Mr. C. J. Waite took the highest award with *Dracena Ernesti*, *Geonoma gracilis*, *Cocos Weddeliana*, *Croton Conntess*, *Aralia leptophylla*, *Aralia gracillima*, and a highly coloured *Croton* without a name.

**BEGONIAS.**—These are perhaps nowhere seen in such superb condition as at Liverpool, some of the plants were of an enormous size, fully 5 feet high and 4 feet through, and in every instance represented care and high culture. For six plants, Mr. A. R. Cox was placed first, Mr. J. Hurst second, and Mr. A. Crosbie third. The leading collection was smaller than the other two, but newer kinds and profusely flowered. For three plants the same exhibitor was again first with excellent plants about 2 feet in diameter. Messrs. A. Crosbie and B. Cromwell were second and third respectively. For one plant the same exhibitor again took the lead.

**GLOXINIAS.**—These were excellent, and have never been seen in such admirable condition. Mr. J. Johnston, gardener to Mrs. Watts, Derwent Lodge, Wavertree, was first, followed closely by Mr. T. Gowan and Mr. J. Agnew.

**FERNS.**—Both the hardy and exotic varieties were well represented, and reflected great credit upon the exhibitors in the various classes. For eight exotic plants, Mr. Lewis was placed first with well grown plants, Mr. A. R. Cox second, Mr. J. Jones being the other prizewinner. For four plants, Mr. B. Cromwell was first with *Gleichenia dichotoma*, *Pteris serrulata major*, *Pteris scaberrima*, *Davallia fijiensis*, very good; second, Mr. J. Hurst. For two Filmy Ferns Mr. Moss was first with splendid plants; for one Fern Mr. C. Cropper was first with a large *Davallia Mooreana*. For six hardy kinds Mr. T. Foster secured honours with excellent plants; second, Messrs. R. Fleming & Sons; third, Mr. P. Barber.

Cockscombs on the whole were good. Mr. J. Agnew, gardener to Mrs. Watts, Grassendale, took the lead for six plants; Mr. J. Hurst was first for four pans of *Achimenes*, with good examples of *Admiration*, *Blue Perfection*, and *Mauve Queen*. For six *Selaginellas*, Mr. J. Leather, gardener to H. Nash, Esq., was deservedly first with neat well grown examples; Mr. J. Harrison, gardener to J. Bateson, Esq., New Heys, Allerton, secured the second, and Mr. T. Jones the third award. *Fuchsias*, except the first prize collection for six plants, were of a very ordinary type, Mr. Hughes, gardener to H. McIver, Esq., Elmswood, Allerton, took the lead with large well-flowered examples; for three plants, Mr. A. R. Cox was accorded the second prize. For two pots of *Liliums*, Mr. T. Lunt, Sefton Park, took the lead, and the same exhibitor was also first for one plant. Mr. Hughes gained the premier position for *Coleuses*, and Mr. T. Gowan for six trained *Zonal Pelargoniums*; Mr. T. Jones was a close second, and Mr. D. McKellar third. For three plants Mr. E. Bridge secured the leading place, and Mr. J. Gowan for four double varieties with fresh well-grown plants. Mr. J. Hurst secured honours for six plants of *Petunias*, and Mr. J. Agnew for six doubles. For three hardy plants Mr. J. Hurst was to the front with grand plants of *Campanula pyramidalis* and *C. p. alba*, and a fine pot of *Lilium lancifolium rubrum*.

**CUT FLOWERS.**—Cut flowers have always been well represented at the Society's Show, but on the present occasion the exhibits are more numerous than ever, and the quality of the Roses excellent. For forty-eight Roses, distinct, no less than six collections were staged, and were fresh and in good condition. Messrs. Cocker & Sons, nurserymen, Aberdeen, took the lead with bright fresh flowers of *Her Majesty*, *Duc de Rohan*, *Marie Baumann*, *Queen of Queens*, *Antoine Ducher*, *A. K. Williams*, *Duke of Edinburgh*, *Mons. E. Y. Teas*, *Alfred Colomb*, *Duke of Wellington*, *Hon. E. Giffard*, *Niphetos*, *Mrs. Jowitz*, *Comte Raimhaud*, *Marie Verdier*, and *Rosieriste Jacobs*; T. B. Hall, Esq., Larch Wood, Rock Ferry, was a good second with smaller but strikingly bright fresh flowers; Messrs. James Dickson & Sons, Newton Nurseries, Chester, third; these lacked that brilliancy that marked the two previous collections. For twenty-four blooms Mr. T. B. Hall was well ahead with large full and very fresh flowers, followed by S. P. Budd, Esq., Bath, with smaller but very neat examples; third, Mr. H. Pettress, gardener to A. Tate, Esq., Roseleigh, Woolton, with large but rather loose flowers. For twelve blooms Mr. T. B. Hall was again successful, the dark blooms being fresh and good. Mr. S. P. Budd, Gay Street, Bath, gained the third prize: no name being placed on the second collection. For twelve Tea varieties E. Claxton, Esq., Woolton, was first with beautifully fresh blooms of *Madame Cusin*, *Louis Van Houtte*, *Princess of Wales*, *Anna Ollivier*, *Souvenir d'un Ami*, *Madame Willermoz*, *Madame H. Jamain*, *Jean Ducher*, *Hon. E. Giffard*, *Catherine Mermat*, and *Madame de Watteville* fine. Messrs. J. Cocker & Sons second, and Mr. T. B. Hall third; six collections in this class. For twelve blooms any dark variety Messrs. Cocker & Sons were first with *Alfred Colomb*; Messrs. Harkness & Sons, Bedale, Yorkshire,



second with the same variety; and Messrs. James Dickson & Sons third with bright flowers of Duchess of Bedford; eight stands were staged. In the corresponding class for twelve light varieties the same exhibitor was again first with Merveille de Lyon; Messrs. Harkness & Sons, second with the same variety; and Messrs. R. Mack & Sons, Catterick Bridge, Yorkshire, third with Baroness Rothschild. For a box of Roses tastefully arranged Mr. T. B. Hall was well first with a handsomely arranged box, the groundwork being formed with *Adiantum cuneatum*. The Rose blooms comprised dark varieties, single blooms, while the Teas used were light and arranged in moderate-sized bunches, according to the size of the flowers. Mr. E. Claxton was second with a box of Tea varieties, very delicate and pretty, but less neat and striking than Mr. Hall's. Mr. H. Peatress was third, with too much green in his arrangement.

Stove and greenhouse flowers were, as usual, shown in very fine condition, some of the winning stands being really superb. For eighteen varieties Mr. B. Cromwell was well first, followed by Mr. W. Bustard, gardener to J. Lewis, Esq., being placed second. For twelve varieties Mr. G. Williams, gardener to S. Baerlin, Esq., Didsbury, gained chief honours, followed by Mr. J. Hurst, gardener to W. B. Bowering, Esq., Beechwood, Aigburth, and Mr. J. Warrington, gardener to T. Bright, Esq., Briarley, Aigburth. Herbaceous cut flowers were really excellent, and for twenty-four distinct kinds Mr. G. Eaton was well to the fore, followed by Mr. W. Bustard, who also showed well. In the corresponding class for twelve varieties Mr. J. Warrington was first with good even blooms; Mr. J. Foster, gardener to J. Brancker, Esq., second; and Mr. D. McKellar, gardener to A. J. Steel, Esq., Bank Hill Road, Aigburth, third. Mr. R. Brownhill, Rock Ferry, took the lead for Carnations with a capital stand of flowers. Bouquets were very neat but call for no special remark, for the flowers in some of the exhibits were not fresh. For two Mr. G. Downes took the lead, and Mr. G. Williams for one. For one vase the last-named competitor was successful with a neat light arrangement.

**FRUIT.**—The display in both the collections and Grape classes was equal, if not superior, to those staged during previous years; in fact the fruit throughout was of the highest quality, and the competition in most classes was very keen. For a collection of eight dishes no less than five collections were staged, and those who failed to gain honours would have gained premier positions at the majority of fruit shows. Mr. J. H. Goodacre, gardener to the Earl of Harrington, Elvaston Castle, Derby, was placed first with excellent Black Hamburg and Muscat of Alexandria Grapes, both being large in the bunch and heavy, while the former were superbly finished. The remaining dishes were fine large examples of Longleaf Perfection Melon, Smooth Cayenne Pine, Barrington Peaches, very large; Circassian Cherries, and Loxford Hall Seedling Strawberries. Mr. J. Edmonds, gardener to the Duke of St. Alhans, Bestwood, Notts, was a close second, having particularly good Elruge Nectarines and Early Grosse Mignonne Peaches. The card of the third prizewinner contained no name at the time of our leaving the Exhibition. In the corresponding class for six dishes four collections were staged, and all in splendid condition. Mr. J. Edmonds took the lead with large well finished bunches of Black Hamburg and Muscat of Alexandria Grapes, Best of All Melon, Brown Turkey Figs, Early Grosse Mignonne Peaches, and Elruge Nectarines. Mr. J. Stoney, gardener to Sir Thos. Earle, Bart., Allerton Towers, was a close second with good Grapes, excellent Stirling Castle Strawberries, Downton Nectarines, and Teton de Venus Peaches. Mr. T. Elsworthy, gardener to A. R. Gladstone, Esq., Court Hey, Liverpool, was the remaining prizewinner. Three competitors staged in the class for a basket of fruit arranged for effect. Mr. J. Stoney secured the premier position with a tastefully arranged basket, containing a collection of hardy fruits and some very fine Peaches, Nectarines, Madresfield Court, and Muscat of Alexandria Grapes. Mr. T. Elsworthy was a very close second, and Mr. J. Bounds, gardener to A. L. Jones, Esq., third. For six dishes of hardy fruits the competition was keen, and Mr. J. Lambert, gardener to Col. Wingfield, Onslow Hall, Salop, took the lead with good dishes of Loxford Hall Seedling Strawberries, Red Currants, White Currants, Raspberries, Cherries, and Gooseberries. Mr. J. Goodacre was a good second, and Mr. L. T. Turner third. For one dish of Cherries Mr. Hare, Wellingore, Grantham, was first with fine fruit of Frogmore Late Bigarreau. Mr. J. Lambert second with Black Heart. Mr. J. Stoney took the lead for Strawberries, with large fruit of Stirling Castle.

Pines were better throughout than has been the case for some years at the Society's exhibitions. For two fruits Mr. J. Bennett, gardener to Hon. C. H. Wynne, North Wales, was deservedly first with two large fruits of Prince Albert; Mr. J. Harris, gardener to Sir H. H. Vivian, Bart., M.P., Singleton, Swansea, second, with capital Queens; and Mr. J. Edmonds third with the same variety. For one fruit Mr. J. Harris took the lead with a handsome Queen.

Grapes were considerably above the average, and although we have seen the competition closer the classes were well represented. For four bunches six or seven collections were staged. Mr. G. Middleton was well first with grand well finished bunches of even size with very large berries of Black Hamburg, Buckland Sweetwater, Madresfield Court, and Muscat of Alexandria. Mr. Goodacre second, having a grand bunch of Muscat Hamburg, well finished but rather small in the berry. Mr. J. Stevenson, gardener to Lieut.-Col. Pilkington, Prescot, having an excellent bunch of Black Hamburg with very large berries. For two bunches of Muscat of Alexandria, Mr. G. Middleton again took the lead with examples far ahead of any other competitor, the bunches being of fair size and compact, while the berries were well coloured and large. Mr. J. Stoney was second with splendid examples, but slightly uneven in the berries. Mr. D. Lindsay, gardener to Sir Thomas Edwards Moss, Bart., Otterspool, was placed third with smaller bunches, the berries and colour being all that could be desired. For two bunches, any other white variety (Muscat of Alexandria excluded) five competitors staged. Mr. J. Bennett took the lead with Duke of Buccleuch in good condition for that variety; Mr. J. Lounds, gardener to S. S. Parker, Esq., was second with the same variety; and Mr. G. Middleton third with Buckland Sweetwater. With two Black Hamburgs there were no less than fourteen exhibitors. Mr. J. Parker, gardener to G. Raynes, Esq., Rock Ferry, gained the coveted position with large superbly finished examples. Mr. J. Wilson, gardener to H. Cunningham, Esq., Wavertree, was second, with bunches equally fine, except the

berries, which were slightly smaller. Third, Mr. J. Stevenson, with good Grapes, that had perhaps the largest berries of any in the Exhibition, but the bunches were rather loose and slightly deficient in finish. For two bunches any other black variety, Mr. G. Barker was again first with very large heavily shouldered bunches of Madresfield Court, but rather short of colour. Second, Mr. W. Wilson, with much better finished bunches, but the size of the former secured for them the premier award. Mr. J. Bennett third with remarkably well finished Alwick Seedling.

**PEACHES AND NECTARINES.**—These on the whole were large and highly coloured. For one dish of Peaches Mr. A. Lewis secured the first place with large fruit of Royal George; Mr. N. E. Owens, gardener to the Hon. R. S. Cotton, Combermere, Salop, with Noblesse, highly coloured for that variety; and Mr. A. Crosbie third with good fruit of Early Grosse Mignonne. In the corresponding class for one dish Mr. J. Edmonds took the lead with splendid fruit of Chancellor; Mr. J. Story closely followed with Teton de Venus, and Mr. Elsworthy with Bellegarde. For one dish of Nectarines Mr. J. Edmonds was first with large fruit named Elruge, but short of colour; Mr. C. Copple, gardener to T. S. Rogerson, Esq., second with Imperatrice, and Mr. J. Stoney third. In the corresponding class Mr. J. Harris was placed first with large highly coloured examples of Elruge; Mr. J. Bennett second, and Mr. T. Hare third.

**MELONS** were largely represented, a large number of fruits being staged in the two classes for the prizes offered. For one green-fleshed variety Mr. N. E. Owens was first with a beautiful fruit of Hero of Lockinge; second, Mr. J. Ward, gardener to T. H. Oakes, Esq., Riddings Hall, Alfreton; and Mr. A. R. Cox third, both showing the same kind. For one scarlet-flesh Mr. G. Gilmour, gardener to Rev. J. G. Leigh, Walton Rectory, first with Duke of Edinburgh, Mr. Hare second, and Mr. G. Lyon, gardener to J. H. Kenyon, Esq., Egerton Park, Rock Ferry, third.

First-class certificates were awarded to Messrs. R. P. Ker & Sons, Aigburth Nursery, for Croton Sunrise, a highly coloured variety with foliage nearly the width of Queen Victoria, but double the length; Croton Gordoni, a short foliaged highly attractive form, freely spotted with yellow and deep crimson; *Aristolochia elegans*, flowering freely; *Phyllanthus Chantieri*, a beautiful decorative plant that will become popular when plentiful; *Davallia tennifolia Veitchiana*; *Nephrolepis rufescens*, very beautiful; *Salaginella Emiliana* and *S. Emiliana amœna*. The same firm was also highly commended for a large and handsome collection of plants, containing many Crotons in the highest state of perfection. Messrs. H. Cannell & Sons, Swanley, Kent, a similar award for *Verhenas*, *Begonia*, and *Pelargonium* blooms, also a first-class certificate for *Pelargonium Goldfinder*, a semi-double scarlet variety. Messrs. F. & A. Dickson & Sons, The Upton Nurseries, Chester, highly commended for a large assortment of choice plants, principally Tuberous *Begonias*. The Horticultural Company (John Cowan), Garston, the same award for a group of Tea Roses in pots, and one of foliage stove plants, and an assortment of bouquets, wreaths, and crosses. Messrs. James Dickson & Sons a first-class certificate for a seedling Carnation named *Grav-tye Gem*, which was previously named at Manchester Mrs. Hole. They were also highly commended for a group of plants, and boxes of *Gadioli* and herbaceous cut flowers. A similar award was made to Mr. G. Downes for a small group of decorative plants.

**VEGETABLES.**—It was naturally expected that the dry hot weather of the past few weeks would tell against the display of vegetables, but such was not the case, for they were staged in larger numbers generally, and in better quality than has before been the case at this Society's shows. Five excellent collections were staged in the open class for twelve dishes. Mr. C. J. Waite, gardener to the Hon. W. P. Talbot, Esher, Surrey, was placed first with grand examples staged in his well known style. This collection comprised Snowdrop Potatoes, Egyptian Turnip-rooted Beet, Globe Artichokes, Sutton's New Intermediate Carrots, clean and good; Reading Perfection Tomatoes, large fine fruit; Sutton's New Marrow, Mammoth Long-pod Beans, White Leviathan Onions, large and good; Duke of Albany Peas, fair; and large samples of Jubilee Beans of the Scarlet Runner type nearly a foot in length. Mr. J. Lambert was a close second, having remarkably fine White Tripoli Onions, good Nutting's Beet, Sutton's Seedling Potatoes, very good; Veitch's Model Carrot, and Williams' Matchless Celery. Mr. E. Shepherd, gardener to Miss Louise Bannerman, Wellington, Salop, a close third; an extra prize being given to Mr. J. Oldfield, gardener to R. W. Biddulph, Esq., Chirk Castle, Ruahon, who also staged well. In the local class for twelve dishes the same number of exhibitors competed for the prizes offered. Mr. J. Stoney secured the leading position with splendid examples of Jackson's Favourite Tomato, Giant Rocca Onions, Lyon Leeks, Canadian Wonder Beans, and Early London Cauliflowers. Mr. A. R. Cox and Mr. J. Rainford, Whiston, were good second and third in the order named. For six dishes no less than seven collections were staged, and the whole were first-rate. Mr. J. Bennett took the lead, having good Early Rose Potatoes, Telephone Peas, Canadian Wonder Beans, Hackwood Park Tomatoes, and White Elephant Onions. Mr. W. Murrey, gardener to A. B. Forward, Esq., The Priory, Gateacre, second, and Mr. J. Lounds third. Seven collections were staged in the class for six dishes of Peas. Mr. T. Winkworth, gardener to R. Brocklebank, Esq., Childwall Hall, was placed first with Evolution. Giant Marrow, Ne Plus Ultra, Harrison's Exhibition Marrow, Sturdy, and President Garfield; Messrs. J. Lambert and J. Stoney second and third respectively. For three dishes eleven collections were staged. Mr. J. Watson, gardener to F. Tobin, Esq., The Old Hall, Aigburth, took the lead with Telephone, Duke of Albany, and Duke of Edinburgh; Messrs. N. E. Owens, and J. Lyon, Fire Grove, Prescot, second and third respectively. For two dishes there were nine entries exhibited, and the winners were Messrs. J. Bounds, and J. Almond, Maghull, no name being placed on the second collection. Potatoes were considerably inferior in size and appearance to those contributed in previous years. For six dishes, Mr. J. Oldfield took the lead with International Kidney, Beauty of Hebron, Vicar of Laleham, Blanchard, Schoolmaster, and Chancellor; Mr. J. Stoney was second. For four dishes the winners were Messrs. T. Almond, W. Harker, and J. Bennett. Cucumbers were good, and the successful exhibitors were Mr. J. Stevenson and Mr. N. E. Owens, the former with Prescot Wonder, and the latter with Telegraph.

Tomatoes were particularly fine. For three dishes, Mr. J. Elsworthy was well first with fine large fruit of Excelsior, Trophy, and Dedham Favourite; Mr. J. Glover, The Grange, Gateacre, second, and Mr. Copple



third. For one dish, Mr. J. Almond was first with Trophy; Mr. G. Eaton followed with the same kind, while Mr. C. Waite was third with Reading Perfection. A special prize (a silver cup) was offered by Messrs. F. & J. Mee, Hot-water Engineers, Wood Street, for six Tomatoes in pots. Mr. J. Stoney was successful with excellent examples of culture, having three plants in each pot laden with fruit.

Implements were not so largely represented as has been the case on previous occasions. The following received silver medals:—Mr. Joseph Bramham, Dale Street, for wirework and boilers; Messrs. F. and J. Mee, Wood Street, for a collection of boilers; Messrs. Bennett Bros., for a collection of wirework. Certificates of merit were awarded to Mr. J. Webster for greenhouse and frames, M. J. Palmer for Jubilee post seats, and Messrs. Franklin & Hocking for a small heating apparatus.

#### SOUTHAMPTON SHOW.—JULY 30TH AND AUGUST 1ST.

THE Royal Southampton Horticultural Society held their twenty-fifth annual summer Show in the grounds at Westwood Park Avenue on Saturday and Monday last, and were favoured by extremely fine weather on both days. The exhibits, both in quantity and quality, well maintained the credit of the Society, and in some departments the merit was of an unusual character for the present season. This was especially noticeable in the fruit and vegetable tent, where the competition for the principal prizes was very keen and the produce excellent. The vegetables comprised some of the best and cleanest specimens we have seen this season; and amongst the fruit were some grand examples of Madresfield Court Grapes of quite an exceptional character, Mr. Ward winning high honours for his examples of this handsome Grape. In the plant department the specimen stove and greenhouse and foliage plants with the groups constituted the leading features. Mr. Lock's plants were in admirable condition; it is quite refreshing to see such clean vigorous well coloured specimens, and this grower amply deserves all the fame he has won in recent years. Mr. Molyneux also exhibited well in these classes, his plants being distinguished by their fresh and healthy appearance, while Mr. Wills was foremost amongst local gardeners, and Mr. James sent a good example of tasteful arrangement in the group class. The cut flowers and floral decoration tent formed another interesting portion of the Exhibition, and there Mr. and Mrs. Chard, as usual, competed successfully in several classes, staging tasteful stands, bouquets, baskets, &c.

All the arrangements were conducted in a prompt and satisfactory manner, the Secretary, Mr. C. S. Fudge, earned the thanks of the exhibitors and all officials.

PLANTS.—Two large parallel marquees were devoted to the plant exhibits, the stove and greenhouse specimens occupying the centre of one, the groups and Ferns had a similar position in the other, and around the sides were placed the Pelargoniums, Fuchsias, Cockscombs, Coleuses, Tuberos Begonias, and other small classes, which added much to the brightness of the Exhibition. The leading class was that for twelve stove or greenhouse plants, six foliage and six in flower, and the prizes offered ought to have brought more competitors. The first prize was £18, the second £15, and third £12, but as there were only three exhibitors the second and third prizes were placed together and equally divided. First honours were gained by B. W. Cleave, Esq., Newcombe House, Crediton (gardener, Mr. G. Lock), with grand specimens in perfect health of the following: Clerodendron Balfourianum, Croton Warreni, superbly coloured; Croton Williamsi, similarly finely coloured; a pair of handsome trained plants of *Lapageria rosea* and *alba*, of globular form and flowering freely; *Erica Thompsoni*, excellent; a huge *Latania borbonica*, *Erica æmula*, very handsome; and *Ixora Duffi*, bearing a number of large trusses. Equal second prizes were awarded to Mr. H. James, Norwood, and to Mrs. Pearce, The Firs, Bassett (gardener, Mr. E. Wills), the best plants in the former's collection being *Allamanda grandiflora* and a magnificent specimen of *Erica æmula*. Mr. Wills having a beautiful *Statice profusa*. Another class was provided for the same number of specimens, but confined to gardeners, the prizes being £10, £7, and £1. Some good plants of smaller size were shown in this class, the Hon. Mrs. Eliot Yorke, Hamble Cliff (gardener, Mr. J. Amys) taking the first place, his finest plants being *Allamanda Chelsoni*, *Stephanotis floribunda*, *Cycas revoluta*, and *Allamanda Hendersoni*. Col. the Hon. H. G. S. Crichton, Netley Castle (gardener, Mr. J. Reynolds), followed, showing *Allamanda Hendersoni* and *Ixora Williamsi* in capital condition. With six flowering plants Mr. James, Mr. Wills, and Col. Pepper, Salisbury (gardener, Mr. J. Curry) were the prizetakers, while for six foliage plants Mr. G. Lock was well ahead, his *Croton volutus*, *Croton Chelsoni* being remarkably beautiful. Mr. Wills was a good second.

The class for a collection of nine miscellaneous plants, not less than three to be in flower, brought several good exhibitors, W. H. Myers, Esq., Swanmore Park, Bishop Waltham (gardener, Mr. E. Molyneux), winning the prize presented by the President of the Society, the Right Hon. Lord Montagu, with capital examples of *Crotons angustifolius*, *Johannis*, and *variegatus*, all well coloured, *Areca lutescens*, *Allamanda Hendersoni*, *Statice profusa*, *Latania borbonica*, and the beautiful *Trachelium ceruleum*, which was figured in this Journal last year. Mr. Blandford and Mr. J. W. Peel were respectively second and third, the former having an excellent *Statice profusa*, and the latter a large and vigorous *Davallia Mooreana*. Mr. Molyneux had the best single specimen foliage plant, a huge globular profusely flowered plant of *Bougainvillea glabra*. Mr. Wills was second with good *Clerodendron Balfourianum*, and Mr. James third with *Statice profusa*. Mr. Lock's *Croton Disraeli* gained the first place in the single foliage specimen class, and Mr. Molyneux was second with *Croton Queen Victoria*, both capitally coloured.

In the group class Mr. H. James won premier honours with a tasteful combination of Orchids, Ferns, and Palms, with an edging of *Isolepis* and *Fittonias*. Mr. Wills was an extremely close second with a bright collection; Mr. Reynolds third; Messrs. J. C. & H. Ranson fourth, and Miss Todd fifth. With a smaller group Messrs. F. E. Chamberlain, C. Burch, and G. Chamberlain were the prizetakers. For both indoor and hardy Ferns Mr. G. Lock was first with fresh healthy examples, followed by Mr. Wills and Mr. Amys. Messrs. Peel, Bunday and Reynolds winning the honours for four indoor Ferns, and Messrs. Wills, Burden, and Bushby for *Selaginellas*.

A choice group of Orchids from J. Bnchan, Esq., Wilton House, Southampton (gardener, Mr. T. Osborne), gained the chief prize in the class, and well deserved a more valuable prize. The plants shown were healthy, and comprised good examples of the following—*Dendrobium Dearei*, in fine condition, *D. superbiens* with two long spikes, *Odontoglossum Uro-Skinneri*, *O. coratatum*, *Dendrochilum filiforme*, *Oncidium macranthum*, *Cypripedium Veitchi*, *Cattleya Schofieldiana*, *Peristeria elata*, and *Masdevallias*. Mrs. Haselfoot, Moor Hill, Westend (gardener, Mr. N. Blandford), was second, showing *Peristeria elata* with three spikes, *Angaloa Clowesi* with five fine flowers, *Maxillaria tenuifolia*, and *Brasavola nodosa* with eight spikes. Mr. Osborne had the best single specimen Orchid, a large *Calanthe veratrifolia*, and Mr. H. James was second with *Cypripedium barbatum*: Mr. Osborn having an extra prize for *Spathoglottis Angustorum* flowering well. With a collection of miscellaneous nursery stock, Messrs. Windebank, Kingsbury, and Ransom were awarded the prizes in that order; the principal honours for Cockscombs, Coleuses, Fuchsias, Begonias, and Pelargoniums being secured by Messrs. Amys, West, Bushby, Wills, Osborne, Blandford, and Windebank.

CUT FLOWERS.—Numerous classes were devoted to cut flowers, but the most interesting were those for table decorations, stands of flowers, bouquets, buttonholes, &c. For three stands Mr. J. R. Chard, Brunswick Nursery, Stoke Newington, was first with a very tasteful arrangement, in which the base was formed of *Lilium longiflorum*, *Marguerites*, *Rondeletia*, *Roses*, *Fern* and *Coleus* leaves, the side stands having *Cattleyas*, *Grasses*, *Calliopsis*, and yellow *Oncidium*. Miss B. Flight, Winchester, and Miss Chamberlain followed. Mrs. Chard was also first for a basket of flowers, and Mr. Chard was awarded first honours for table decorations in his best style, the base of the central stand being formed of the scarlet *Lilium chalcidonicum* and *L. longiflorum*, very effective. In the ball bouquet classes Messrs. Perkins and Son, Coventry, were placed second with what many considered much the best of those staged, and the awards in that class seemed to be strangely inverted altogether. Messrs. Perkins & Son were first with buttonhole bouquets, very light and graceful. Mr. Molyneux was first with both single and double Zonal Pelargoniums, and he deserved similar honours for hardy flowers. Messrs. Keynes, Williams & Co., Salisbury, were first for Dahlias, with grand flowers.

FRUIT.—The competition was very keen in the classes devoted to fruit, and the general quality was excellent for the season. The Southampton Tramways Company offered the first prize of £5 for a collection of six dishes of fruit, and this was gained amongst nine exhibitors by Lady Ashburton, Melchet Court, Reading (gardener, Mr. Evans), who had capital bunches of Muscat of Alexandria and Madresfield Court Grapes—the latter with fine berries, but slightly rubbed—Barrington Peaches, Read's Scarlet Flesh Milan, Elrue Nectarines, and Brunswick Figs, all of fine quality. R. B. Sheridan, Esq., Frampton, Dorchester (gardener, Mr. S. Pullman), was second; his best dishes being Buckland Sweetwater and Black Hamburg Grapes, Hero of Lockinge Melon, and Noblesse Peaches. Mr. Ward was third; and Sir J. W. Kelk, Bart., Tedworth, Marlborough (gardener, Mr. G. Inglefield), was fourth. The Grape classes were filled, and the exhibits close in merit. For three bunches of black Grapes Mr. Ward, Salisbury, was first amongst seven competitors with grand examples of Madresfield Court; the bunches compact, the berries large, and colour excellent. Mr. Molyneux followed with capital bunches of Black Hamburg; Capt. Davison, South Stoneham House (gardener, Mr. T. Hall), was third with Madresfield Court; and Mr. Inglefield fourth with Black Hamburg. Mr. Pullman had the best two bunches of black Grapes, well coloured samples of Black Hamburg. Mr. Wm. Sanders followed with Madresfield Court; Mr. W. W. Browning was third, and Mr. Richards fourth, with Black Hamburg. In the class for three bunches of white Grapes, Mr. J. M. Stewart Boldre, Grange Gardens, Lynton, was first with Muscat of Alexandria in admirable condition; Mr. J. Evans was second with smaller bunches of the same variety, but with large well coloured berries. Mr. J. Budd and Mr. J. Hall were second and third; the last having Buckland Sweetwater fairly good. Mr. Richards was first for two bunches of white Grapes; remarkably fine Buckland Sweetwater. Mr. S. Pullman following with the same variety; Mr. S. Browning third, and Mr. Sanders fourth. Twelve single bunches of black Grapes were shown; Mr. Molyneux leading with Madresfield Court, beautifully coloured and compact bunches; Mr. T. Hall followed with Black Hamburg, and Mr. Evans and Mr. Ward with Madresfield Court. There were also ten single bunches of white Grapes: Mr. Richards gaining the first place with Buckland Sweetwater, very handsome; Mr. J. Budd was second; Mr. Stewart third; Mr. Ward fourth, all showing Muscat of Alexandria. Mr. J. Budd had the best six dishes of outdoor fruits, Peaches, Nectarines, and Melons being well shown by Messrs. Curtis, Pullman, and Sanders.

VEGETABLES.—These were remarkably well represented, but we can only allude to them briefly. For a collection of twelve varieties the Earl of Carnarvon, Highclere Court (gardener to Mr. W. Pope), was first with excellent produce; J. East, Esq., Longstock House, Stockbridge (gardener, Mr. Wm. Sanders), was a close second; Mr. Amys, third; and Mr. W. Palmer, Thames Ditton House, fourth. For nine varieties of vegetables Mr. Molyneux was first, showing very fine specimens; Mr. J. Allen, Mr. Busby, and Mr. A. Richards were the other prizetakers.

The miscellaneous exhibits comprised a choice collection of Tuberos Begonia blooms from Messrs. J. Laing & Co., Forest Hill, and several groups of plants from local nurserymen.

#### ST. NEOTS SHOW.—AUGUST 1ST.

THE quiet and quaint little town of St. Neots, on the borders of Huntingdonshire was rendered unusually lively on Monday last by the exhibition of the local horticultural Society, which was held in the Cambridge Paddock. The Society is a flourishing one with plenty of supporters, both amateurs and professionals, whose chief desire is to make their Show as successful as possible, and this year, although it was once feared there would be a serious falling off, especially in the cottagers' department, there were numbers of competitors who contributed freely from the produce of their gardens. The Show is not confined to horticultural exhibits, as classes are devoted to honey, farm produce, poultry, cage birds, and rabbits, so that four or five large tents were required to contain all the exhibits. Two of the largest were appropriated to the horticultural portion of the Exhibition,

plants, flowers, fruits, and vegetables being well represented from gardeners, amateurs, and cottagers. The exhibits were well arranged, and the Society is fortunate in having such an enthusiastic and energetic Secretary as Mr. Ratobelons.

Messrs. Wood & Ingram, Huntingdon, contributed a collection of Carnation and Picotee blooms remarkably fine and fresh, representing some select varieties, including several very meritorious novelties of their own raising, St. Gatien, a light rose-flake Carnation, and Candelmas, a pink and purple bizarre, being very notable.

In the plant classes Mr. W. G. Redman, gardener to J. H. Goodgames, Esq., was the principal exhibitor, and carried off the chief prizes in most of the classes. He had some excellent plants, but his six specimen Fuchsias were especially handsome, fine conical plants, 6 feet high and 3 or 4 in diameter, loaded with flowers. The same exhibitor had the best six stove and greenhouse plants, well grown plants of Anthurium Schertzerianum, *Ixora javanica*, *Bougainvillea glabra*, *Clerodendron fallax*, and *Stephanotis floribunda*. For a single specimen Mr. Redman was first with *Bougainvillea glabra* in very fine condition, and the Duke of Newcastle's (gardener, Mr. T. Colbourn), second with *Oncidium crispum*. Bateman Brown, Esq. (gardener, Mr. Tilbrook), won first honours for four stove and greenhouse Ferns with excellent specimens of *Adiantum concinnum* *latum*, extremely fine; *A. Williamsi*, *A. farleyense*, and *A. Collisi*. Mr. Redman following with *Platycerium alcorni*, *Adiantum farleyense*, *A. gracillimum*, and *A. cuneatum*. Mr. Redman had the best four hardy Ferns, and Mr. Tilbrook was second with smaller plants. The same exhibitors contributed in several other classes. Mr. Tilbrook was first with a single specimen Fern, showing a grand specimen of *Platycerium alcorni*, very large and in wonderful health. Mr. Petfield was first with ten table plants, light, graceful, little specimens.

Cut flowers were numerous, and in that department again Mr. Redman was a prominent exhibitor. Dahlias were capitally shown by A. J. Thornhill, Esq. (gardener, Mr. R. Petfield), who had some extremely fine blooms, for which he won the first prize. Miss Cheere, Papworth Hall (gardener, Mr. Smith), had twelve bunches of hardy flowers, and won the premier prize. E. B. Lindsell, Esq., Hitchen, had a superb stand of twenty-four Rose blooms, fresh and richly coloured, easily winning the premier prizes both for these and in the classes for twelve Teas and twelve Hybrid Perpetuals.

In the fruit classes, Mr. Tilbrook was first with a collection of six dishes, showing two magnificent Smooth Cayenne Pine Apples, quite overpowering the other exhibitors. The Earl of Sandwich (gardener, Mr. Myers) was a good second, showing a Melon, Peaches, Apricots, Cherries, in good condition; Captain Duncombe (gardener, Mr. Carter) being a close third with two fine bunches of Grapes. With one bunch of Black Hamburg Grapes, Mrs. Medland (gardener, Mr. Warboys) was first with a well coloured bunch of good size, Mr. Petfield being second. In the any other black variety class, Mr. J. Topham, Thorney Park, was first. In the Muscat of Alexandria class, Mr. Myers took the lead, followed by Mr. Redman; and for any other white variety, Mrs. Day was first, showing Buckland Sweetwater in good condition, and Mr. Warboys second with the same variety. Mr. Smith had the best flavoured scarlet flesh Melon, and Mr. Carter the best green flesh Melon. Apricots from Mr. Hardwick and Mr. Myers were excellent, several others also showing these fruits well. Apples, Currants, Gooseberries, Tomatoes, and Cherries were all well represented, the winners of the prizes for collections of vegetables being Messrs. Redman and Myers. The Judges were Mr. J. Wood-Ingram and Mr. L. Castle.

## ROSE SHOW.

### WEST OF SCOTLAND (HELENSBURGH).

AFTER an interval of two years I had again this season the pleasure of again seeing the Helensburgh Show, and having a "crack" with many old friends. I found but little change; the place where the Show was held was not the same, it is true, but the method of exhibiting was unaltered. The same familiar faces were happily to be seen, and the same heartiness manifested, but at the same time I am bound to say there was no improvement; there was too much carelessness in many of the amateurs' exhibits, wrong naming and duplicates were not uncommon, and the general style and character might easily be better. True it has been a most trying Rose season, and the later shows have felt it more than the earlier ones. It was late, too, as the season, turned out, for Helensburgh, for it is a mistake to suppose that Roses are so much later in this part of Scotland than in England, and hence there was altogether a falling off both in the quantity and quality of the flowers. Even those from the North of Ireland and Stranraer were not up to their usual excellence, although there were some good flowers amongst them.

In the class for forty-eight blooms, distinct, Mr. Hugh Dickson, Belmont, Belfast, was first with Madame Charles Wood, Comtesse de Serenye, Ulrich Brunner, Abel Gaud, Marguerite de St. Amand, Etienne Levet, Paul Neyron, Marie Baumann, Merveille de Lyon, Mrs. Jowitz, Princess of Wales, Benoitte Comte, Madame Eugene Verdier, Princess Amadie de Broglie, Lælia, Madame Victor Verdier, Alfred Colomb, Madame Gabriel Luizet, Duc de Rohan, Madame Marie Finger, Star of Waltham, Heinrich Schnltheis, Duc de Marlborough, Princess Mary of Cambridge, Louis Van Hontte, Maréchal Niel, Senateur Vaisse, Duchesse de Vallombrosa, Charles Lefebvre, Marquise de Castellane, Horace Vernet, Countess of Rosebery, Her Majesty, Xavier Olibo, White Baroness, Comte Raimbaud, Pride of Waltham, Prosper Laugier, Alphonse Soupert, Elie Morel, Madame Engénie Frény, Mons. E. Y. Teas, La France, Marie Rady, and Lord Bacon. In the class for thirty-six varieties Messrs. A. Dickson & Sons of Newtonards in the County of Down were first with Comte Raimbaud, Madame Marie Verdier, François Courtin, Prince of Wales, William Koelle, Madame Louis Devigne, Brightness of Cheshunt, Lady Sheffield, Annie Wood, Her Majesty, May Queuall, Madame Engénie Verdier, Ulrich Brunner, Merveille de Lyon, Duchesse of Bedford, Lady Mary Fitzwilliam, Ferdinand de Lesseps, François Michelon, Earl of Dufferin (a fine new Rose of Messrs. Dicksons' raising), Emilie Hausberg, Comtesse de Camando, Lælia, E. Y. Teas, Baroness Rothschild, Senateur Vaisse, Star of Waltham, Duke of Albany, Madame Marie Finger, Baron Hausmann, Madame Gabriel Luizet, Princess

Amadie de Broglie, Madame Charles Crapelet, Etienne Levet, Comtesse de Serenye, Louis Van Houtte, and Madame Nachury. In the class for twelve Teas or Noisettes Mr. Thomas Smith of Stranraer was first with Maréchal Niel, Madame Hippolyte Jamain, Madame Willermoz, Paul Neyron, Niphotos, Etoile de Lyon, Perle des Jardins, Madame Denis, Madame Berard, Cornelia Kock, Catherine Mermet, and The Bride.

In the class for gentlemen's gardeners, Mr. William Parlange, gardener to Col. Deconton, was first for thirty-six, with Merveille de Lyon, Paul Neyron, Maréchal Niel, Sir G. Wolseley, Egeria, Alfred Colomb, Lord Macaulay, François Michelon, Captain Christy, Camille Bernardin, Comtesse d'Oxford, Duke of Edinburgh, Gloire de Dijon, A. K. Williams, Edouard Morren, Ulrich Brunner, Madame Clemence Joigneux, Marie Baumann, Comtesse de Serenye, Ahel Carrière, Perle des Jardins, Prince Arthur, Madame Levêque, Baroness Rothschild, Paul Jamain, Hippolyte Jamain, Baron Gonella, Marguerite de St. Amand, E. Y. Teas, Madame Verdier, Eugene Appert, La France, Madame Victor Verdier, Marie Finger, and Pierre Notting.

These were the principal classes, and the smaller ones call for no particular comment. The N.R.S. silver medal for the best Hybrid Perpetual in the Show was taken by Mr. Hugh Dickson with Pride of Waltham, and there was no Tea or Noisette shown sufficiently good to merit the award.

My visit to Helensburgh, besides the Rose Show, afforded me an opportunity of seeing the nursery of Mr. Alex. Campbell of Gourack. It will be remembered that two years ago he very much astonished the frequenters of the Crystal Palace and South Kensington by the magnificent groups of Gladiolus which he set up, especially that which he showed at the latter place in the second week of October. Knowing the moisture of the climate in which he grew them I was very anxious to see his collection, and to hear about his harvesting the corms, for I imagined that a place where the average rainfall is double what it is in Kent, and from whence a collection of spikes could be shown in October, would present some considerable difficulties to a grower. I found Mr. Campbell an intelligent and good gardener, and, like all good gardeners, ready to impart his knowledge to others. Two things particularly struck me—the small number of corms, comparatively speaking, which he cultivates, I do not know the exact number, but there were only a few heds. The second matter which surprised me was the closeness of the corms; they certainly were not more than 4 inches apart, and yet the plants all looked healthy and vigorous. This is very different from the practice of many growers (myself amongst the number), who allow 1 foot between the corms. Mr. Campbell, too, mashes his heds with cocoa-nut fibre, a precaution I should hardly have thought necessary in such a climate as Gourack. He does find a difficulty in harvesting as I imagined he must, and he also experiences a considerable amount of loss. He does not believe either in the degeneration of the corms or exhaustion, but where he loses them believes it to be, as do most Gladiolus growers, the result of disease, probably occasioned by moisture. I have seen a good many Gladioli this year, and I do not recollect any season when they have up to this period looked so well. The foliage is green and strong, there are very few signs of going-off, such as one has had to deplore, and if they continue like this, it will go far to prove that a hot and dry season is what they rejoice in. This might have generally been expected, as they come from Natal, where the hot summers correspond to that which we are now experiencing. It will be seen that Mr. Campbell's method of growing differs considerably from that of Mr. Burrell and myself. To me the closeness at which the corms are planted would seem to be an erroneous practice, especially when it comes to the matter of shading, for it must be very difficult to get the boxes in between the spikes of blooms; however, it is done, and we know with what success.—D., Deal.



### HARDY FRUIT GARDEN.

**MAIN CROP AND LATE STRAWBERRIES.**—Where the plan of forming fresh beds with newly rooted runners is followed these ought really to be now well established in 3-inch pots. Some seasons plenty of well-rooted plants can be lifted with a trowel from among the rows of old plants, but they are far from being plentiful this year, and if not already done no time should be lost in layering a quantity either into small pots or on turves. Select the healthiest, and which are just forming roots, as any that have lost their roots or have been trampled on are useless. Use good loamy soil and make this firm in the pots, and which require no drainage. The runners may be trimmed and then fixed in position with a stone or peg. If kept well supplied with water they soon fill the pots with roots, but they should be cut away from the parent plants and bedded out before they are badly root-bound. We prefer the lifted plants to those layered into pots, the former frequently taking the most readily to their fresh quarters; but either will do well if properly planted and attended to, and should give a crop of fine fruit next season. In the meantime a breadth of ground should have been prepared for them. They cannot be relied upon to always bear well unless they are rooting in freely manured deeply dug ground; but if the soil is both rich and loose, too many leaves and not much fruit will be the result. If the ground is double dug at the present time, some rough manure being added to the bottom and partially rotten manure mixed with the top spit, a little time must be allowed for settling, and in any case it should be heavily trampled prior to planting. We prefer to trench the ground during the winter. It is cropped with early Potatoes, which delight in deeply worked loose ground, and these leave it in excellent condition for the Strawberries. In any case, whether the ground is dug



one or two spits deep, it must be well manured, or the plants will not grow so vigorously as could be wished. If the Onions are cleared off early the ground they occupied would form a capital Strawberry bed, being both rich and firm. All that would be necessary in this instance would be to clear the ground of weeds, and the planting be completed without any further trouble. The rows may well be 30 inches apart, and the plants 24 inches apart in the rows. This may appear more room than is necessary, but crowded plants never bear so well as those given plenty of space, and in wet seasons especially the clusters of fruit must have all the light and air possible or they rot off wholesale. Onions, Lettuces, Spinach, or Beans may be grown between the rows during the season following planting, though if the plants do well they will occupy much of the available space. When the young plants are put out they ought to be in a moist state at the roots, and the soil should be well primed about them with the handle of the trowel. In dry weather they will need occasional waterings, or otherwise they will progress very slow.

**SELECTION OF STRAWBERRIES.**—Allusion was made to early varieties on page 61. To succeed those grown for the earliest supplies the preference may yet be given to Sir J. Paxton, this fine second early sort invariably doing well. President is a little later, and is also still one of the heaviest croppers, the fruit also being of excellent quality. La Grosse Sucrée succeeds well in some places, but we have discarded it. James Veitch is a very fine sort, and worth growing principally on that account. Sir C. Napier, though not very hardy, usually crops heavily, and the quality pleases those who prefer briskly flavoured fruit. Unser Fritz grows freely and yields large crops of very fine fruit, and this again is more remarkable for its appearance than good quality. Auguste Nicaise is good for pot culture, but is of less value for the open ground. Dr. Hogg, if it could be induced to grow vigorously on all soils, would be a general favourite. With us it is of sturdy growth, cropping heavily, and the fruits are large, firm, and good. British Queen, unfortunately, is very fickle, but where it can be induced to do well it is a great favourite. Loxford Hall Seedling is very late and of fairly good quality, but on all sides we hear complaints that it refuses to grow strongly. Eleanor or Oxonian, on the other hand, though not of very high quality, possesses a good constitution, is very late, and produces extra heavy crops of fine fruit. The most reliable, given in their order of ripening, are Sir J. Paxton, President, Sir C. Napier, Dr. Hogg, and Eleanor. It is advisable, however, to try some of the newer sorts, the nature of the soil much affecting the character of the varieties grown on it.

**OLD STRAWBERRY BEDS.**—Three, or at the most four, good crops are all that is worth while to take from a plantation. Every season an old bed should be destroyed and a new one formed, and in this manner only can a first class supply of fruit be maintained. The youngest plants give the earliest and finest fruit, but the second year's crops are usually the most valuable, though a greater number of fruits may be gathered during the third or fourth seasons. Directly the fruit is gathered from an exhausted bed, it should at once be cleared off, both plants and weeds going to the fire heap. Then without any digging the ground ought to be cropped with Broccoli or Savoys, these being extra hardy on firm good ground. The younger plantations give the best runners, and in most instances these are not interfered with till the selected runners are removed. A simple plan of preparing a lot of young plants for forming beds early next season consists of pricking out a number of runners, if with plenty of roots attached so much the better, on a spare border in nursery beds. If these are kept from fruiting next season, they will make fine plants for putting out early, or any time from June till August. After the runners are obtained the plants in the reserved beds should be cleared of all surplus runners and much of the old foliage, and this with the rough litter should be wheeled away and burnt. Any decayed mulching may well be left undisturbed, it is the rubbish and weeds that need removing.

**DRY WEATHER AND THE FRUIT CROPS.**—The long drought is proving very injurious to the fruit crops—notably Apples and Pears, and these are dropping off wholesale. It will be some time before many of the trees get sufficient moisture at the roots, and there is every prospect of the produce being small. It is almost useless to attempt watering the larger trees, but wall trees, pyramids and bushes may, in many instances, be given a good soaking with advantage. Thinning out is yet needed on many small trees that come under our notice. It is not yet too late to do this important work, and strong Grape scissors are very handy for the purpose.

#### FRUIT FORCING.

**MELONS.**—The weather has been splendid for Melons. We have never known them better than they have been this year, especially those in pits and frames that have the benefit of a bed of leaves and dung. Frame Melons seem to always have a firmer, sweeter, and more agreeable flavour than house Melons, indeed they have more of the true Melon flavour. The plants are not so coddled, having, as a rule, much more air, continuous supplies of nutriment, therefore have more highly elaborated juices.

Late crops in frames are setting well, and as the plants usually grow luxuriantly, the foliage should be kept thin, or they may set indifferently and after setting refuse to swell. Some growers object to the use of the knife to the plants whilst the fruit is setting, but we do not hesitate to cut out superfluous growth whenever the necessity arises, and with the best results. Crowding the foliage tends to nothing but disaster. The blossoms do not set well, the fruits swell badly, and, worse still, they have large seed cavities, are hollow, and have neither weight nor quality. Copious supplies of water are necessary about twice a

week to plants swelling their fruit with a sprinkling over the foliage at closing time, those in houses being well syringed both ways in the afternoon, and a good moisture maintained by dampening available surfaces in the morning and noon. Do not neglect to fertilise the flowers daily of plants now in bloom, and to go over them frequently for stopping or removing superfluous growths. Keep the atmosphere dry when the fruit is ripening and setting. Maintain a bottom heat of 80° to 85°, top heat 70° at night and 75° by day; in dull weather admit a little air at that if the day is likely to be fine, allowing the heat to rise to 80°, then admit more air and keep it through the day at 85° to 90°, closing so as to increase to 90° or 95°. A free circulation of rather dry warm air greatly improves the finish and quality of Melons when ripening. If fruit be wanted very late make a last sowing now. Eastnor Castle, Longleat Perfection, and Scarlet Perfection are good free-setting and swelling sorts. The plants for fruiting in October should be planted at once, it being equally important with those raised from seed now that they have a light and well-heated structure.

**FIGS.—Early-forced Trees in Pots.**—As soon as the second crop is gathered examine the trees, for keeping the trees somewhat drier at the roots and the drier condition of the atmosphere consequent on a free circulation of air tend to an increase of red spider and scale. These pests are almost inseparable from Fig culture in heated structures, so that the cultivator requires to be ever on the alert. Still the enemies steal a march upon the grower, especially during the ripening of the fruit; therefore, when that is cleared off the trees, recourse must be had to cleansing, and as the foliage and wood is far advanced in ripening destructive agents may be employed at a strength which would not be safe at an earlier stage. If, therefore, those pests, and especially scale, have made undesirable progress, it will be advisable to syringe the trees with a petroleum solution—a wineglassful to 4 gallons of water in which 8 ozs. softsoap and 1 oz. soda has been dissolved, one person stirring the mixture briskly with a broom handle whilst another applies it with a syringe to the trees, so as to thoroughly wet every part of the trees, the under as well as the upper part of the foliage and all the wood. To prevent the mixture soaking into the soil a little dry moss may be tied around the stem, and then a sort of pyramid of the same placed about the plants. If the wood is badly infested employ a somewhat stiff brush for freeing it of the scale whilst wet. In bad cases repeat this in the course of a day or two, afterwards syringing thoroughly with tepid water. The trees will need very little further attention, only giving water to prevent the foliage becoming limp, ventilating to the fullest extent day and night; but protect the trees from heavy rains, which has a tendency to keep the trees active instead of inducing that rest so desirable for those subjected to early forcing. For those considerations the old practice of placing early-forced pot trees outdoors is now little practised, the trees being continued under glass, complete repose being sought in dryness. If placed outdoors, it must be in a sunny position, and the pots stood on a layer of ashes with similar material about them, and though they must not be allowed to suffer for want of water, material must be at hand to throw off heavy rains in order to prevent the soil becoming sodden. Whether kept under glass or placed outdoors they cannot have too much light or air.

**Early-forced Planted-out Trees.**—The second crop is ripening and will need a circulation of air constantly, more, of course, by day than at night; if dull wet weather prevail a gentle heat in the pipes makes all the difference between well ripened and insipid fruit. Watering at the roots must be diminished, and syringing discontinued, but a moderate air moisture may be allowed for the benefit of the foliage. If red spider is present and there is heat in the pipes coat them thinly with sulphur, or a good syringing may be given after the fruit has been closely picked, choosing a time when there is a prospect of the moisture not remaining long upon the trees. As soon as the fruit is all gathered the trees may have a good washing with the syringe or garden engine to free the foliage of dust and red spider, otherwise a free circulation of dry warm air should be maintained in the house until the foliage begins to fall naturally, and which must not be accelerated by allowing the soil to become dust dry at the roots of the trees.

**Unheated Houses.**—In order to insure a crop of Figs with certainty, glass cases or structures with a south aspect are indispensable. The trees succeed capitally if the roots are restricted to narrow borders (one-third the width or height of the trellis is ample), well drained, and not more than 2 feet deep, composed of good loam of a calcareous nature, or adding a sixth of old mortar rubbish, which contains what Figs require in lime and silica, or a fifth of chalk may be added, and a sixth of road scrapings. If the loam be rather light add a fourth of clay chopped small and intermixed, which requires to be placed together rather firmly to induce a short-jointed sturdy habit. With unobstructed light and provision for free ventilation Figs of the choicest description may be obtained if the usual attention is given in watering through a mulch of partially decayed, rather lumpy manure, and feeding with liquid manure as required. It is also necessary that the growths be thin, acting upon the extension system, but securing by judicious stopping a fair amount of spurs. In no case allow more growth to be made than can have full exposure to light. The fruit is now well advanced in swelling, therefore spare no pains to keep the foliage clean by syringing in the morning and early afternoon. Do not syringe, however, if the day is likely to be dull, or in the afternoon if there is no prospect of the foliage becoming dry before night. Under such circumstances damp the border, especially in the afternoon, with liquid manure. Admit a little air early, increasing it with the sun heat, maintaining through the day at 80° to 85° with free ventilation, closing early



so as to run the temperature up to 90° or 95°, and when the sun's power is declining a little air may be admitted at the top so as to allow the pent-up moisture to escape, the temperature gradually cooling down. Water or liquid manure, according to circumstances, will be required once a week or oftener, in order to keep the soil thoroughly moist. When the fruit begins to ripen lessen the supply of water and discontinue syringing, securing a circulation of air constantly, and freely ventilate when favourable, but sun heat should be husbanded, and will do no harm if the atmosphere is not confined, a little ventilation being given so as to allow of the moisture escaping instead of condensing on the fruit and causing it to crack.

**PINES.**—Clean houses thoroughly as they become vacant before being again occupied with plants. Bottom heat being necessary, the first thing to be seen to is the bed. If bottom heat be afforded by hot-water pipes, the material forming the bed, whether of tan or leaves, should be removed at least once a year, or insects, particularly woodlice, rapidly increase; the old material also harbours other predatory vermin. All brickwork must be scalded and brushed with hot lime, the wood and iron work with soap and water thoroughly cleansed, using a brush, keeping the soapy water as much as possible from the glass, which should be cleaned inside and outside with water only. If necessary the wood and iron work may be painted, the roof being made as watertight as practicable. Beds that are chambered—*i.e.*, the hot-water pipes covered with slate or other material, are very much in advance of those surrounded or passing through beds of rubble. Those composed of the latter should be turned over, and any dirt or small parts removed to allow the heat given off by the pipes to penetrate through the whole uniformly to the bed. Fresh tan should be provided in other cases. If wet turn it occasionally on fine sunny days. With hot-water pipes beneath about 3 feet depth of tan this is ample, more will be needed where such aid is not obtained.

Suckers that were started in June will soon fill their pots with roots, and must be shifted into larger pots before the roots become closely matted together. Queens should have 9 and 10-inch pots, and those of stronger growth 11-inch pots. Water immediately after potting, and plunge in a bed having a temperature of 90° to 95°. There is no greater mistake in growing Pines than crowding young plants. The plants become drawn and weakly instead of having a sturdy base, a condition that should always be aimed at. Attend to the bottom heat of beds that have been recently disturbed or upset by the removal or replacing of plants, not allowing the heat to exceed 95° at the base of the pots without immediately raising them, as too much bottom heat will disastrously affect plants with fruit or those having the pots filled with roots. Examine the plants for watering about twice a week, and maintain a moist, genial, well ventilated atmosphere. The climatic influences are now so favourable, that Pine plants grow luxuriantly, therefore discontinue any shading such as may have been employed for an hour or two at mid-day, when the sun was powerful through the months of May, June, and July, the plants after this having the benefit of every ray of light, admitting air plentifully when the temperature ranges from 85° to 95°, affording to fruiting plants a night temperature of 70° to 75°, and succession 65° to 70° at night. Reserve, if possible, another batch of suckers on the stocks for starting at the commencement of September.

**CHERRY HOUSE.**—The buds are now plump. The leaves, too, will not be capable of much further effort in elaborating sap and storing it up in the buds and adjacent wood, therefore any undue excitement will cause the trees to start into growth, which must be guarded against by exposing the trees to the influence of the atmosphere so far as the house will admit, which is the best means of arresting premature growth, to which the Cherry is liable when forced year after year successively. The border must not be allowed to become parchingly dry, but must have a copious supply of water, and if the trees are weak afford liquid manure. To subdue red spider give an occasional washing with the syringe or garden engine. Black aphides can scarcely keep long off Cherry trees, but the leaves and wood, from their hard texture, are not inviting to them, yet if they appear promptly use tobacco water. Trees in pots must be regularly watered and syringed to maintain the foliage in a healthy condition as long as possible.

#### PLANT HOUSES.

**Tree Carnations.**—All the earliest rooted Carnations are growing rapidly and fast filling their pots with roots. They must have weak stimulants every time they need water, clear soot water, or that made from cow manure being good for them; or, better still, artificial manure applied to the surface of the soil at intervals of two or three weeks. If neglected in this respect growth comes to a standstill, and flower spikes appear before they are wanted. Plants that are allowed to become root-bound early in the season are almost certain to come into flower in early autumn long before they are wanted. We have found it a good plan to place into larger pots any that are likely to become root-bound too early. Every care is needed afterwards for a time in watering until the roots are working freely amongst the fresh soil. Later plants may be placed into their largest size, those 6 inches in diameter being suitable. Such varieties as Gloire de Nancy, Souvenir de la Malmaison, and others that are intended for flowering early indoors in 6-inch pots next season should be rooted at once, either by layering or by taking off the cuttings and inserting them singly in small pots, placing them under handlights

in a cool shady position. The former is the more certain method, and the one we generally adopt, except the plants from which the cuttings are to be obtained are in pots; then they are rooted under handlights. Plants of these varieties that flowered in 6-inch pots and have been well cared for since are now in 8-inch pots, and may be transferred into others 2 inches larger. In this size they will make grand plants and produce six to eight flower stems each, that will prove either useful for cutting or be objects of beauty in the conservatory. If given greenhouse treatment during the winter they will commence producing their flower stems early, and will be in full flower towards the end of April and throughout the following month without unduly forcing them.

**French and Fancy Pelargoniums.**—Young plants raised from cuttings that were pinched and hardened to cool frame treatment directly they were rooted may now be placed in 5-inch pots. The soil, which should consist of good loam and one-seventh of manure, should be pressed firmly into the pots to insure a firm sturdy growth. These plants may be kept close for ten days or a fortnight, and afterwards grown perfectly cool in frames with the lights off. Pinch the shoots when they have made two or three leaves to insure their remaining dwarf. The shoots should be pinched when they need it until the last week in August or the first week of the following month, but not afterwards. By this treatment they will have broken into growth again by the time they are in their winter quarters. Old plants that were pruned back early and started again into growth in a frame may now have the old soil shaken from their roots and the plants repotted in fresh soil, placing them in much smaller pots, repotting them as growth extends. These must be kept close for a time until they are rooting freely in the new soil, when they may be hardened and grown under airy treatment. Prune plants that have been well ripened, and start them in a frame until they break into growth. Those that are now going out of flower must be stood for two or three weeks in a sunny position to ripen them before they are pruned back. Harden all young plants raised from cuttings, and then grow them in a cool house, but fully exposed to the sun. Good cuttings may still be rooted, and for this purpose it is better to top the earliest plants than to insert old flower stems.

**Zonal Pelargoniums.**—Those for autumn and winter flowering need liberal supplies of water at their roots, and liquid manure two or three times weekly, or every time water is needed, according to the condition of their roots. The pots in every case should be well crammed, the wood short-jointed and firm. Decaying leaves and flowers as they appear should be removed. Plants that have grown tall may be cut close back, and a good batch of cuttings inserted for early spring flowering. Double varieties should also be inserted for the same purpose, and for yielding a good supply of trusses for cuttings during next May, June, and July, or longer if needed. Insert them singly into 3-inch pots, in which they will pass the winter safely. Cuttings at this season root well either outside or in a cold frame.

**Silenes.**—In order to have the plants of good size before the winter the seed should be sown at once. They are very effective spring-flowering plants.

#### THE FLOWER GARDEN AND PLEASURE GROUND.

**Layering Carnations.**—Layering is the surest method of securing abundance of strong young plants for flowering next season. The plants to be operated on should be cleared of all old flowers, and after the roughest of the surface soil has been removed a good soaking of water may be given. Next surround them with a good depth of loamy compost with which plenty of road grit or sharp sand has been added. Select the best placed shoots, and not far from the centre cut them half through just under a joint, next cut upwards through the joint, and then peg them down firmly in the soil. If this is properly done, and a little water given occasionally in dry weather, roots soon form on the "tongued" joints, and in due course a well rooted plant can be detached and transplanted or potted up without any check being given. This important work should be done as early in August as possible.

**Annuals for Spring Flowering.**—The second or third week in August is a good time for sowing the seeds of *Saponaria calabrica*, both red and white; and *Gypsophila elegans*, *Alyssum maritimum* and *Candytufts* may be sown at the same time. At the end of the month may be sown the *Nemophilas*, *Virginian Stocks*, *Lasthenia californica*, *Limnanthes Douglassi*, *Collinsia bicolor*, *grandiflora* and *verna*, and *Erysimum Peroffskianum*. The ground for them should be light and good, and if at all dry be moistened prior to sowing the seeds. We prefer to sow broadcast and thinly, covering the seeds with a little fresh soil. Thus treated the seed germinates quickly, and the seedlings grow sturdily, little or no thinning out being needed. In the autumn all will transplant readily and will be much more hardy than those drawn up in crowded rows. The *Silenes* ought to have been sown in July, and the *Forget-me-nots*, *Wallflowers*, *Sweet Williams*, *Campanulas*, *Brompton Stocks*, and other biennials in May, and the seedlings pricked out at the present time.

**Propagating Tuberos Begonias.**—Where plenty of short growths can be obtained either from pot plants or large plants in the open ground these may be dibbled out in fine sandy soil and left to take care of themselves. A sunny spot is necessary, and the cuttings are best pulled off, and not trimmed in any way. They quickly strike root and form little tubers for starting next spring.

# THE BEE-KEEPER.

## NOTES ON BEES.

### THE WEATHER.

JULY has been less favourable for honey gathering than June was. The much-needed refreshing showers that fell during the former month lessened the honey yield, but has done much good to crops and vegetation in general. The temperature of July was high, and it has been altogether a pleasant month in the north, and although it yielded less honey than June much was gathered, and in well managed apiaries there are large quantities of honey of the finest quality.

### THE HEATHER.

The Heather is early and promises well. I took a few Syrian hives to the Lead Hills on Wednesday the 20th ult., and never witnessed bees work better than they did that day, but I regretted to observe that a frost on the morning of the 18th had completely blackened the haulm of the Potatoes in the district. I shall take the main stock of our bees to the Heather by the 27th, giving them one to two covers of supers according to their strength, which, with a week's fine weather, the bees will nearly fill; afterwards, the weather being favourable, I shall attend daily to their wants until the honey flow ceases. All my hives are extra well in numbers, so that it is impracticable to join two or more together, and all must go as they are. The ventilating floor and slight openings between combs prevent smothering or overheating, which causes foul brood, and care in packing and driving the horse will prevent combs collapsing. I shall veil myself before the bees are let loose, so that they will not be irritated, and to prevent a rush when opened I shall hold carbolised feathers or paper close to the entrance, but keep it from the alighting board. A mat or piece of sacking will be hung loosely round the hive, and supers well covered with soft material, over which a galvanised sheet of iron bent and held in place by wire, so as to form a half circle, completes the dressing and protecting of our hives. The nights being colder than in July ventilation will not be so necessary.

### DISEASE OF BEES.

I am obliged to Dr. G. Walker, Wimbledon, for his trouble to ascertain the cause of the death of the bees sent him in May, but the malady had passed away before I had his request for more dead bees. I failed to properly understand Dr. Walker's reply regarding the frosted pollen being the cause of the disease. Will he therefore say whether he meant pollen that had been stored during the previous summer and frosted during winter was the cause of the disease, or was it pollen gathered from flowers that had suffered from frost during May? If he meant the former then I cannot agree with him, because the bees would die earlier in the season and would not appear during May at all, as by that time many hives suffering from the disease end of May had no pollen in their hives that had been gathered in the previous year. If, however, he attributes the disease to the pollen of flowers blooming and frosted in May, then it is reasonable to suppose that frosted pollen injures adult bees.

Then to get at the bottom of the problem we must take into consideration both the time and how the bees die. They leave the hive apparently in good health to forage for honey and pollen. I cannot say how many, if any, die in the fields when in search of provisions, but I have witnessed many die immediately they returned from

the fields with their burdens the moment they alighted on the landing board. They seemed to be attacked at first by paralysis, then two or three convulsive fits ended their lives, and hundreds die in a short time. The only examination or test I ever made was a simple dissection. In every case their intestines were filled with a greenish matter, which I had some fears that the bees had been indulging in something oozing from coppered ships which were lying in the harbour.

I think there is a great deal of misunderstanding amongst bee-keepers respecting what are diseased bees. When many dead bees are around, which sometimes perplexes and vexes the owner, it is imagined that some fatal disease has attacked their hives, when in reality no disease exists, the suspected bees being nothing more nor less than bees of hives in an unsatisfactory state either in some apiary near or may be bees located in the roof or other part of the building whose stores are exhausted or queen gone. At all times of the year in some place or other there are stray swarms which annoy other bees.

There can be no mistake in identifying bees suffering either from that May disease or what I termed chloric dropsical fever; but it is not only a mistake, but misleading, to describe all bees that are found dead as diseased ones, and bee-keepers would do well to examine carefully and minutely all bees found dead in numbers, but not to become alarmed at the occurrence, as many dead bees at a hive is more often a sign of health and strength than disease.

### HONEY FAIRS.

What are bee-keepers thinking of the abundant harvest of honey, and what steps do they intend taking to get it disposed of? Will the Honey Company purchase and pay a fair price in ready money for all the honey, which is enormous this year? Or will they and others concerned give the honey fairs a trial without prejudice, and so help the bee-keepers of Great Britain, which they profess to do, to dispose of their large quantities and fine qualities of this year's honey?

There is the B. H. C. on the one hand, ostensibly for the sole purpose of benefiting bee-keepers, and on the other the B. B. K. U. for the same purpose. Would it not be wise for the promoters of both schemes to shake hands and give the latter a fair trial, which will prove its efficacy? My opinion is that honey fairs conducted in a proper manner would do more good for bee-keepers in one season than all the exhibitions have done during the past decade. I trust that Dr. Walker will take this view of the matter, and take the initiative, along with Mr. Hewitt, before continental bee-keepers get the first opportunity.—  
A LANARKSHIRE BEE-KEEPER.

### HEAVY HONEY YIELD.

I DO not know if the following will interest your readers. I copy it from the *Dumfries and Galloway Standard* of July 23rd, 1887:—“The Reverend Mr. Taylor, Kirk Andrews-on-Esk, one of the best known and extensive apiarists on the Borders, has remarkable experiences to record. From his apiary of over twenty hives he has taken 670 lbs. of honey. The present is the most fruitful season in his whole experience, and the month of June of this year has been the finest of honey gathering he ever remembers. One of his hives, which consists of a swarm put into an empty hive on the 18th of June, has yielded already the extraordinary amount of 84 lbs. of honey, and it has at present a quantity ready to be taken off. During the eight days from June 26th to July 3rd this hive increased 55 lbs., an average of nearly 7 lbs. daily.

Another hive on June 12th weighed 79 lbs.; on the 18th, 100 lbs.; 19th, 106 lbs.; 20th, 109 lbs.; 21st, 116 lbs.; 22nd, 122 lbs.; 23rd, 128 lbs.; 24th, 134 lbs.; 25th, 140 lbs.; 26th, 146 lbs.; 27th, 151 lbs.; 28th, 156 lbs.; 29th, 162 lbs.; 30th, 167 lbs.; July 1st, 173 lbs.; 2nd, 178 lbs.; 3rd, 186 lbs.; 4th and 5th, 185 lbs.; 6th, 189 lbs.; 7th, 197 lbs.; 8th, 204 lbs.; 9th, 206 lbs., being a total increase of 127 lbs., there being a decrease on 4th and 5th of July.—A NORTHERN BEE-KEEPER.

## HANTS AND ISLE OF WIGHT BEE-KEEPERS' ASSOCIATION. EXHIBITION, SOUTHAMPTON, JULY 30TH.

THE annual Exhibition of honey, hives, bees, &c., was held, as usual, in the grounds of Westwood Park in connection with the Royal Southampton Horticultural Society's Summer Show. As might have been expected from such a hot season, and Hampshire being particularly rich in wild flora, the show of honey was very large and of excellent quality, said to be the finest yet brought together. The competition was exceedingly keen, as many as nineteen entries being staged in some classes, thus rendering the task of judging most arduous. At such a Show as this it is a pity that the arrangements both for exhibitors and judges were not a little more complete, the first named certainly ought to be considered a little more. It was as late as 10.30 A.M. before any exhibitor could stage his exhibit owing to the lateness of the arrival on the ground of the Hon. Secretary or his assistants to mark out the places. This is a serious matter for those exhibitors reaching the Show ground early in the morning to stage their exhibits, and wishing to return to their occupation during the day. More confidence, too, would be placed in the awards if judges were appointed for all the classes, not depending upon any chance exhibitor acting in the capacity of judge. We should like to see a better method of arranging the super honey adopted instead of standing the supers singly on the tables one in front of the other, thus causing each one to be lifted separately for examination, as was the case on this occasion in many instances. The general public, too, would have a much better view of the whole exhibit; as it now stands only about two supers out of each exhibit are easily seen—those in the front. It may be that in this case the worst ones are those examined, thus the public form a wrong idea of the quality of the exhibits. The system adopted by a few exhibitors—viz., that of showing one super above another in double tier, enclosing all in a clean glass case, seems to be a step in the right direction, in this manner the whole sections can be seen at once.

Class 1 was for the best 24 lbs. of super honey in sections not exceeding 2 lbs. each, for which a silver medal was offered for the first prize, a bronze one for the second, and a certificate as third. Mr. W. Hunt, Odiham, was placed first with capital samples, Mr. W. Woodley second, and Mr. H. W. West, Swanmore, third. For 12 lbs. of pure extracted honey staged in vessels not exceeding 2 lbs. each, Mr. W. Woodley was placed first, showing honey wonderfully clear in colour and solid; Mr. J. J. Candy, Landport, was second, and Mr. W. Hunt third. The first prize for the best design worked in honeycomb by the bees was awarded to Mr. W. Woodley for a clear design of the letters "V.R." Mr. A. Privett, Bishop's Waltham, was second, whose design, "Jubilee 1837 and 1887," was capital, considering its intricacy, but not so clear as the first prize design; Mr. S. Candy was third. For the best and most complete bar-frame hive, price not to exceed 20s., there was only one entry, to whom the prize was awarded, Mr. J. Tanner, Ringwood. For the most recent invention or inventions calculated to be of use to the bee-keeping industry, the first prize was awarded to Mr. W. Woodley for section racks, the second to Mr. S. Fry, Bishops Waltham, for honey drinks.

The following classes were open to members residing in Hants or within three miles of the boundary lines:—For the best 12 lbs. of sugar honey in sections not exceeding 2 lbs. each, Mr. E. Ainsley, Swanmore, secured the first prize, a silver medal, for a splendid exhibit of 2 lb. supers, quite squarely built, evenly sealed, and of good colour. The Rev. P. Izard, Winchester, was placed second with honey much darker in colour, but squarely built, and of good quality. Mr. C. Richmond, Swanmore, was a close third, he staging capital specimens. For the best 12 lbs. in 1 lb. sections (eleven staged) first honours falling to Mr. Thomas Giles, Salisbury, second Mr. W. Hunt, third Rev. W. E. Medlicott. In the class for 12 lbs. extracted honey in 1 lb. or 2 lb. vessels there were nineteen competitors, making a brave array. The first prize fell to Mr. J. Dauncey, Basingstoke, with a splendid exhibit. Second Mr. J. J. Candy; and Mr. Russ, Winchester, was third. For the same quantity and under the same conditions, open to cottagers only, Mr. A. Stephens, Christchurch, was first, second Mr. G. Holly, third Mr. A. Broom, Newtown. Beeswax was contributed largely, the best, a first-rate sample, coming from Mr. W. Burgess, Christchurch, second Mrs. W. Burgess, third Mr. A. Broom. During the afternoon lectures were given by Rev. W. E. Medlicott, Swanmore, upon the management of bees in general, illustrating the remarks by driving and other manipulations, which proved very interesting.

### CYPRIAN AND CARNIOLIAN BEES.

LIKE Mr. Kent I have read with much interest the remarks of "A Lanarkshire Bee-keeper" on foreign bees. Would "A Lanarkshire Bee-keeper" please tell us how we could procure these bees at the cheapest rate? as there are many cottagers about here that have never seen them, but having heard of the superiority of the foreign bees would like to have them, but the prices of the dealers are so high that working men cannot procure them. Would "A Lanarkshire Bee-keeper" tell us which races of these bees are most suited to the cottager, when to buy them, and how to work them? "A Lanarkshire Bee-keeper" said some time ago that the only fault the Carniolians had was that they swarmed often. How could this be prevented to make them gather surplus honey, as I think they would be useful?—G. REMMER.



## TO CORRESPONDENTS

All correspondence should be directed either to "THE EDITOR" or to "THE PUBLISHER." Letters addressed to Dr. Hogg or members of the staff often remain unopened unavoidably. We request that no one will write privately to any of our correspondents, as doing so subjects them to unjustifiable trouble and expense.

Correspondents should not mix up on the same sheet questions relating to Gardening and those on Bee subjects, and should never send more than two or three questions at once. All articles intended for insertion should be written on one side of the paper only. We cannot reply to questions through the post, and we do not undertake to return rejected communications.

**LATE INQUIRIES.**—It is necessary to again remind correspondents that letters arriving on WEDNESDAY MORNING cannot be answered in the "next issue," which is then far advanced for press.

**Showing Roses (B. P.).**—If there was the required number of varieties in the stand the judges could not disqualify the exhibitor, unless it is expressly stipulated in the schedule that they should be correctly named.

**Tomato Growing Without Ventilation (H. W. G.).**—So far as we know the Prescott Cucumber growers do not grow Tomatoes without ventilation; but we are open to correction upon the point. We have seen many tons of Tomatoes grown under glass, the plants about a yard apart in rows down the floor of the house, and secured to stakes. Some are also trained to trellises as a matter of convenience, especially in low narrow houses.

**Cherry Reine Hortense (W. S.).**—No doubt this is the variety to which you refer. We recently saw some good examples of it in your district. It is thus described in the "Fruit Manual," with quite a host of synonyms:—"Fruit very large, 1 inch and one-twelfth long and an inch wide, oblong, and compressed on the sides. Skin very thin and translucent, at first pale red, but assuming a bright cornelian red, and changing to dark brilliant red the longer it hangs. Stalk very slender, about 2 inches long. Flesh yellow, netted, very tender, and very juicy, with a sweet and agreeably acidulous juice. A very excellent Cherry of first-rate quality. It ripens in the middle and end of July. The tree is a free and vigorous grower and an excellent bearer. It was raised in 1832 by M. Larose, a nurseryman at Neuilly, near Paris, and first produced fruit in 1838."

**Use of Unheated Frames in Winter (H. W. G.).**—The best use that can be made of frames from a marketing point of view is to devote them to protecting and growing salading, such as Endive and Lettuce. The frames that will be at liberty from November to January may be used for protecting Endive, which should be sown in July, and the plants grown in good rich soil in the open ground so as to have strong plants by October, during which month protective material should be at hand for placing over the plants in case of severe frost, which, though only of a temporary character, will impair if not destroy the crop. In November the Endive may be lifted and planted in the frames in moist rich soil. The plants will be as large as desired, and will only require blanching, which should be effected by tying the plants whilst dry from three weeks to a month before required for use. Air should be admitted on all favourable occasions, tilting the lights when the weather is wet but mild, it being important that they be kept dry, whilst in mild dry weather the lights may be drawn off. In cold frosty weather protection in addition to the lights is necessary, but we protect our Endives by a plan that suggested itself on the score of utility, as mats are costly. The plan is so soon as the Endives are tied we fill the spaces between the plants and over them to a depth of about 3 inches with dry Oak or Beech leaves, which aids the blanching, and is effectual as a protective material, and in damp weather absorbs moisture. The Endive come out capitally; only use the lights for throwing off rains, the one essential in having salads in winter is the exclusion of wet. With well-grown plants, and care in excluding wet and frost, first-class Endive can be had from November to January inclusive. The soil we use is moderately light loam and leaf soil or thoroughly decayed manure in about equal parts, and in a thorough state of moisture, but not sodden so as to obviate the need of water. We sow about the middle of July. The varieties are Improved Round-leaved Batavian and Green-curl Improved. For spring use a sowing may be made early in this month. The plants being well attended to will be fit to transfer to the frames in November, and will come into use in February and March. The treatment is the same as for the others, only they must not be tied, and do not attempt blanching until they are sufficiently grown. It is very important that they be safe from frost by the use of sufficient protective material over the lights and against the sides of the frames in severe weather, not removing the material during its prevalence until the setting-in of general thaw. If the frost penetrates the frame and the plants get frozen the protection should not be moved until the plants are thawed. The frames that will be at liberty from November to March may be utilised for Lettuces, which should be raised from seed sown at the end of July or not later than early August, they being duly thinned so as to insure sturdy plants for putting out in early November in the frames. The soil should be rich and moderately firm, so as to promote vigorous growth. Draw the lights off whenever the weather is mild and fair; they may remain on, but tilted, so as to insure a circulation of air whenever the weather is wet, and when frost prevails keep close, covered with mats or other material so long as it remains, and when the plants are frosted allow them to remain covered and in the dark until



thoroughly thawed. The great enemy is damp, therefore ventilate, and after the middle of February growth may be accelerated by moderate ventilation through the day and closing early in the afternoon, so as to husband the sun heat. Water will of course be necessary in the spring, giving it in the morning of a prospective fine day. The best varieties are Veit h's Perfect Gem, Early Paris Market, and All the Year Round. If the season be a late one the Lettuces may not be fit to cut until April, but we have often been driven to the expedient of moving the frames and protecting the Lettuces with mats, having sticks hoop-fashion to keep the mats off the plants, the plants being well hardened previously. We have very often been surprised to find that we had finer and heavier Lettuces in that way than by continuing the lights over the plants. In that way we have had early Cos, and the best of those is Hick's Hardy White and Bath or Brown Black-seeded. The frames may also be employed for affording protection to Cauliflower plants, which will bear exposure after March, or the frames may be used for early Radishes, sowing so soon in the new year as the weather is favourable. The best for this purpose are Extra Early White Forcing Turnip, Extra Early Scarlet Forcing White Turnip, French Breakfast, and Wood's Frame, the two first bringing us the best returns. Radishes require a rich light soil, moderately firm.

**The Pear Tree Slug (*H. L., Dumow*).**—The best remedy for this troublesome pest is to dust the trees frequently with quicklime. In reference to this insect, Curtis—under the head of "*Tenthredo adumbrata*"—says, "Arboriculturists are familiar with a slimy black larva like a little leech which appears as if glued to the leaves of Pear trees, and which is of



Fig. 12.—*Tenthredo adumbrata* (larva state).

very common occurrence in fruit gardens in September and October. From its form and appearance Réaumur called it the slug-worm. At the end of autumn, when it has attained its full size, it somewhat resembles a small tadpole. It has twenty feet, which, however, cannot be seen without dislodging it from the leaf. It does not begin at the edges of the Pear leaf, but gnaws away the parenchyma in the middle, leaving the smallest veins

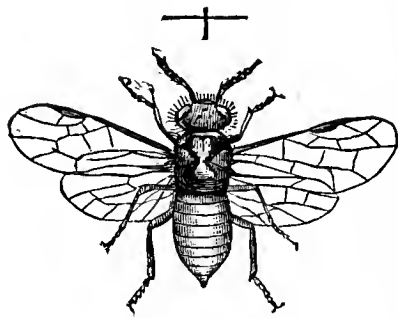

Fig. 13.—*Tenthredo adumbrata* (perfect insect).

and the epidermis of the under side untouched, so that the leaves attacked are left like the finest lace. After four times casting its skin it changes to an orange-yellow colour, comes down from the tree, and forms a cocoon from particles of soil bound together by a few silken threads. The perfect insect, according to Hartig, is  $2\frac{1}{4}$  lines long, smooth, black, and shining, with the horns almost as long as the abdomen; the legs are black, the joints and thighs reddish-brown, the wings obscure." The grub is frequently very destructive to wall trees. It appears on Pear trees when the fruit are from one-half to two-thirds of their full size, and by destroying the parenchyma of the leaves it prevents the elaboration of the sap, brings growth to a standstill, and the Pears, instead of swelling, drop. Some authors consider that the slug worm of Réaumur produces the *Tenthredo Cerasi* of Linnæus; others consider it to belong to the *Tenthredo Æthiops* of Fabricius. The investigations of Gorsky, Westwood, and M. Delacour, have set the question at rest. They have shown that there are several slug like grubs which are developed into insects belonging to distinct species, and that the *T. Cerasi* of Linnæus does not form its cocoon in the ground, but amongst the leaves of the Cherry.

**House for Marechal Niel Rose Cultivation (*S. S.*).**—This superb Rose is grown in a lean-to house at Burghley and other places, and in span-roofs at Ascot and others. A description of the Ascot houses and Roses was published in the Journal on page 21, January 14th, 1886. For early work lean-to houses have an advantage over spans, but that makes little difference when the season is advanced. The width of the house is not material, as we have seen quite as fine Roses in a house 6 feet wide as in one of four times the width; the chief consideration is to allow the growths plenty of space to develop in with full exposure to light, therefore in a narrow house it is a question of having less plants, they having in any case plenty of room. When Marechal Niel Rose does well it will make a growth of 20 feet, and much more in a season, and that extent of run of trellis should be allowed. An 18 feet lean-to is a good width, having front or side lights of about 2 feet 6 inches resting on brickwork just clear of the

ground. The back wall is not much use, and ought not to be less than 15 feet high from the floor line, which may be very well where a wall exists, but where it would have to be built a span-roofed house would be much the best, having it from 20 to 24 feet wide, with side lights of about 2 feet 6 inches in height, but that is not material for boarded sides do just as well, and need not be more than 18 inches high; a board of 9 inches width fixed just beneath the eaves plate with 4-inch butts and opening outwards from the bottom the whole length of the house will give all the needed bottom ventilation. There will also need to be double the extent of top ventilation, and it is best in lantern fashion. The ends of a span should be north and south, and to have a proper pitch should be two thirds the width, or for a house of 24 feet width with 18-inch sides, 9 feet 6 inches in the centre from the floor to the under side of the ridge. Hot-water pipes will be necessary, and we should have two rows—a flow and return 4-inch pipe for a 24 feet wide house, fixed 4 feet from the sides and clear of the soil by 6 inches. The roof may be trellised, the wires 12 inches from the glass, planting the Roses on both sides 3 feet apart. The border should be inside, planting the Roses about 18 inches from the sides. The roots may have the run of outside as well as inside borders. A good sound loam inclined to be heavy rather than light, with a sixth of old lime rubbish, a sprinkling of crushed bones, and a fifth of leaf soil, well incorporated, and laid 2 feet thick on a foot of sound drainage, will with surface mulchings of decomposed manure grow this Rose grandly. Do not force the growth the first season by rich feeding, but let the plants get well hold, and then it will send up shoots 20 or 30 feet long that give blooms from every well-ripened bud, and the feeding can then be of a higher order, using liquid and richer surface dressings. The finer the blooms the better the returns. Most Marechal Niel Roses are ruined by hurrying them in the first year with flowering them too profusely in the second. Let them get hold before they are allowed to carry full crops.

**Watering and Sprinkling Plants in Hot Weather (*W. J. Page*).**—The subject is, as you say, undoubtedly important. One of the best gardeners has stated that the great rule for watering plants in general is to "give enough water to reach every root, and give no more watering until it is required." The continuous drizzle system ruins thousands of pot plants, and is just as injurious, if persevered in, to vegetable and flower beds. A good soaking when wanted, and stirring the surface afterwards to keep the moisture in, or at least to render evaporation of moisture very gradual, would be worth a score of the continuous every day or every evening shower baths. Of course we make an exception as respects newly planted things, where the mere refreshing of the foliage will often be of more importance than deluging the soil with water. We have frequently noticed plants taken from the same place and planted under similar circumstances, and in one case they would be thriving, and in the other case they would be miserable-looking, the crust of the earth being pretty well as hard as pavement, and produced by the great labour of almost continuous surface waterings. Let us try briefly to explain the cause. Sow a seed or get a plant established in well-stirred soil, and however dry the surface, the more powerful the sun, the greater will be the amount of moisture raised from the subsoil beneath the roots of the plants, the roots having the benefit of that moisture as it passes them and is discharged into the atmosphere, to form part of the future showers that will refresh the earth, and which will generally come in dry weather. This would form one reason against frequent indiscriminate rose sprinklings, as being so far not called for; but they are not only useless for established plants, but they are worse than useless, because actually injurious, and from two causes. First, by mere surface sprinklings surface rootlets are encouraged, which are burned up and withered as the surface moisture that encouraged them is dried up; and, secondly, these surface sprinklings confine the evaporation to the surface, and thus break the connecting link of the capillary action which would have brought moisture to the roots from greater depths. The sprinkling does not reach the body of the roots, and it stops the rising even of vapour from depths beneath them, so that the roots are deprived of moisture both from above and beneath, and they fall into much the same state as many a row of early earthed Celery does when done after the general approved fashion, the stems running, and the earth about the roots being as dry as if it had been baked in an oven. Thirdly, the watering of tender plants turned out of doors must be regulated by the other considerations, so long as cold forms an element to be guarded against. Here one of the first elements of success is having the ground warm, and great drenchings, unless with water considerably heated, and the surface stirred and rendered dry, will ever cool the soil by evaporation. In such cases the less water the plants have at the roots, so long as they have enough to keep them growing, the better will it be for them, and the faster they will grow. We have seen bedding plants flooded at an early period, which we should not think of doing had we ever so much water at command. A very little at the roots, that had been well warmed by the sun's rays, would be better in such circumstances than a great quantity, because the greater the quantity the more the ground would be cooled by evaporation. Hence a cold rain in the end of May or the beginning of June, in such circumstances, is only a little better than a severe frost, and is to be guarded against accordingly. Hence, also, when plants are damp enough at the roots, and yet the leaves flag under a powerful sun, it is often better to moisten the foliage by a slight sprinkling, to arrest evaporation, instead of deluging the roots or soaking the surface soil. Even if the sun shines this sprinkling of the foliage will do no harm, and it wonderfully refreshes the foliage, and is quite a different thing from wetting the surface of the ground. The little that may fall on the surface of the ground from such a damping of the foliage is quickly raised about the plants in the shape of a refreshing vapour, a very different effect being produced from what takes place when a bed is sprinkled over regularly from one-eighth to half an inch deep. We know that frequently more good is done in this way by a few pailfuls of water from a syringe or garden engine, than from many given at the roots when they cannot appropriate it. In such cases of transplanting or repotting, sudden changes from dull to bright days demand more in the way of evaporation from the foliage than the roots, though moist enough, can at once supply; and the arresting or modifying of the evaporation, either by sprinkling the foliage, or, better still, where practicable, shading for a time, gives the plants a better chance in all respects than deluging the roots with cold water.

**Names of Plants.**—We only undertake to name species of plants, not varieties that have originated from seed and termed florists' flowers. Flowering specimens are necessary of flow-ring plants, and Fern fronds should bear spores. Specimens should arrive in a fresh state in firm boxes. Slightly damp moss or soft green leaves form the best packing, dry cotton wool the worst. Not more than six specimens can be named at once. (A. C.)—An attenuated variety of *Polystichum angulare*. (*Orchid*).—*Lælia elegans*. (H. C.)—1, *Eryngium amethystinum*; 2, *Lysimachia vulgaris*; 4, *Leycesteria formosa*; 6, *Lythrum Salicaria*; 3 and 4 were not recognisable.

**COVENT GARDEN MARKET.—AUGUST 3RD.**

THE bulk of the soft fruit has now arrived and buyers are getting stocked, prices remaining the same. Trade quieter.

**FRUIT.**

	s. d.	s. d.	s. d.	s. d.
Apples, 1/2 sieve .. ..	0	0	0	0
Nova Scotia and Canada barrel	0	0	0	0
Cherries, 1/2 sieve .. ..	3	0	6	0
Ccbs, 100 lbs. .. ..	0	0	0	0
Figs, dozen .. ..	1	6	2	0
Grapes, per lb. .. ..	1	6	2	6
Lemons, case .. ..	10	0	15	0
Melon, each .. ..	2	0	3	0
Oranges, per 100 .. ..	6	0	12	0
Peaches, dozen .. ..	2	0	6	0
Pears, dozen .. ..	0	0	0	0
Pine Apples, English, per lb. .. ..	1	6	0	0
Plums, 1/2 sieve .. ..	0	0	0	0
St. Michael Pine, each	3	0	5	0
Strawberries, per lb. ..	0	0	0	0

**VEGETABLES.**

	s. d.	s. d.	s. d.	s. d.
Artichoker, dozen .. ..	1	0	2	0
Asparagus, bundle .. ..	0	0	0	0
Beans, Kidney, per lb. ..	1	3	0	0
Beet, Red, dozen .. ..	1	0	2	0
Broccoli, bundle .. ..	0	0	0	0
Brussels Sprouts, 1/2 sieve	0	0	0	0
Cabbage, dozen .. ..	1	6	0	0
Capiscum, per 100 .. ..	1	6	2	0
Carrots, bunch .. ..	0	4	0	0
Cauliflowers, dozen .. ..	3	0	4	0
Celery, bundle .. ..	1	6	2	0
Coleworts, doz. bunches	2	0	4	0
Cucumbers, each .. ..	0	4	0	6
Endive, dozen .. ..	1	0	2	0
Herbs, bunch .. ..	0	2	0	0
Leeks, bunch .. ..	0	3	0	4
Lettuce, dozen .. ..	0	9	0	0
Mushrooms, punnet .. ..	0	6	1	0
Mustard and Cress, punt.	0	2	0	6
Onions, bunch .. ..	0	3	0	6
Parsley, dozen bunches	2	0	3	0
Parsnips, dozen .. ..	1	0	0	0
Potatoes, per cwt. .. ..	4	0	5	0
" Kidney, per cwt. .. ..	4	0	0	0
Rhubarb, bundle .. ..	0	2	0	0
Salsafy, bundle .. ..	1	0	1	6
Scorzoneria, bundle .. ..	1	6	0	0
Seakale, basket .. ..	0	0	0	0
Shallots, per lb. .. ..	0	3	0	0
Spinach, bushel .. ..	3	0	4	0
Tomatoes, per lb. .. ..	0	4	0	6
Turuips, bunch .. ..	0	4	0	6

**PLANTS IN POTS.**

	s. d.	s. d.	s. d.	s. d.
Aralia Sieboldi, dozen ..	6	0	12	0
Arbor vitæ (golden) dozen	6	0	9	0
" (common), dozen .. ..	0	0	0	0
Azalea, dozen .. ..	0	0	0	0
Begonias, dozen .. ..	4	0	9	0
Calceolaria, dozen .. ..	3	6	8	0
Cineraria, dozen .. ..	0	0	0	0
Creeping Jenny, dozen ..	3	0	4	0
Dracæna terminalis, doz.	30	0	60	0
" viridis, dozen .. ..	12	0	24	0
Erica, various, dozen .. ..	12	0	24	0
Euonymus, in var., dozen	6	0	18	0
Evergreens, in var., dozen	6	0	24	0
Ferns, in variety, dozen	4	0	18	0
Ficus elastica, each .. ..	1	6	7	0
Foliage Plants, var., each	2	0	10	0
Fuchsia, dozen .. ..	3	0	9	0
Geranium (Ivy), dozen ..	4	0	6	0
" Tricolor, dozen .. ..	3	0	6	0
Hydrangea, dozen .. ..	9	0	12	0
Lilias Valley, dozen .. ..	0	0	0	0
Lilium lancifolium, doz.	12	0	18	0
" longiflorum, doz. .. ..	18	0	30	0
Lobelia, dozen .. ..	3	0	5	0
Marguerite Daisy, dozen	6	0	12	0
Mignonette, dozen .. ..	3	0	6	0
Musk, dozen .. ..	2	0	4	0
Myrtles, dozen .. ..	6	0	12	0
Palms, in var., each .. ..	2	6	21	0
Pelargoniums, dozen .. ..	6	0	15	0
" scarlet, doz. .. ..	3	0	9	0
Spiræa, dozen .. ..	6	0	12	0

**CUT FLOWERS.**

	s. d.	s. d.	s. d.	s. d.
Abutilons, 12 bunches ..	2	0	4	0
Anemones, 12 bunches ..	0	0	0	0
Arum Lilies, 12 blooms ..	3	0	6	0
Azalea, 12 sprays .. ..	0	0	0	0
Bluebells, 12 bunches ..	0	0	0	0
Bouvardias, bunch .. ..	0	6	1	0
Camellias, blooms .. ..	0	0	0	0
Carnations, 12 blooms ..	1	0	2	0
" 12 bunches .. ..	4	0	6	0
Cornflower, 12 bunches ..	1	6	3	0
Daisies, 12 bunches .. ..	2	0	4	0
Encharis, dozen .. ..	4	0	6	0
Gardenias, 12 blooms ..	1	6	3	0
Hyacinths, Roman, 12 sprays	0	0	0	0
Iris, 12 bunches .. ..	2	0	3	0
Lapageria, white, 12 blooms	0	0	0	0
Lilium longiflorum, 12 blooms	3	0	6	0
Lilao (white), French, bunch	0	0	0	0
Lilies, White, 12 bunches	12	0	24	0
" Orange, 12 bunches ..	9	0	12	0
Lily of Valley, 12 spray	0	0	0	0
" 12 bunches .. ..	0	0	0	0
Marguerites, 12 bunches	2	0	4	0
Mignonette, 12 bunches	2	0	4	0
Myosotis, 12 bunches ..	2	0	3	0
Narciss, 12 bunches .. ..	0	0	0	0
" White English, bch.	0	0	0	0
Pansies, 12 bunches .. ..	2	0	4	0
Peas, Sweet, 12 bunches ..	3	0	6	0
Pelargoniums, 12 trusses	0	9	1	0
" scarlet, 12 trusses	0	4	0	6
Pinks, White, 12 bunches	1	0	4	0
" various, 12 bunch	2	0	4	0
Pocouy, 12 bunches .. ..	0	0	0	0
Poinsettia, 12 blooms ..	0	0	0	0
Primula (single), bunch	0	0	0	0
" (double), bunch .. ..	0	9	1	0
Polyanthus, 12 bunches ..	0	0	0	0
Ranunculus, 12 bunches ..	0	0	0	0
Roses, 12 bunches .. ..	2	0	6	0
" (indoor), dozen .. ..	0	9	1	0
" Tea, dozen .. ..	1	6	3	0
" red dozen .. ..	0	0	0	0
" de Moiss. 12 bunches	0	0	0	0
Stephanotis, 12 sprays ..	1	6	3	0
Tropæolum, 12 bunches ..	1	0	2	0
Tuberose, 12 blooms .. ..	0	6	1	0
Tulips, dozen blooms ..	0	0	0	0

which must be in pasture. Out of six farms which we have to let there was not one answering to that description, for they are all in the great corn-growing district of East Anglia, where in the "good times" nobody ever thought of having much more than a tenth part of a farm in pasture. Such a state of things was all very well then, but now it unquestionably answers best to have a considerable proportion of a farm under pasture either temporary or permanent.

Of all the farms we have in hand the home farm answers best. It is 320 acres in extent, of which 217 acres are laid down to permanent pasture. We have a flock of cross-bred ewes upon it, and we make upwards of 100 tons of hay for sale. The outlay for labour is lower than it is upon any of our other farms, and if corn-growing continues to be such an arduous undertaking we shall very probably lay down much more of the other farms to pasture. The farm which answers next best to the home farm is of precisely the same size, but it has only 80 acres in permanent pasture, but to this we may add extensive layers of Clover. This farm is of an exceptionally good mixed soil, and the crops this year are excellent without exception. Here, too, we keep an ewe flock and a large number of pigs. The corn crops are so heavy, and the corn is generally of such high quality, that we should hesitate very much before laying any more of this land down to pasture, but we might add one or two temporary mixed layers. Wheat, Barley, Oats, Peas, Beans, White and Red Clover for seed, all in due proportions, will continue to be cultivated there profitably even under the present depression, for last year there was a handsome margin of profit after the deduction of £1 an acre for rent and paying tithe, taxes, labour, and all other incidental expenses. This year we hope to do better, for the crops are certainly heavier and the quality of the corn will probably also be higher.

We turn from our best corn farm to a still larger one of some 340 acres; a heavy land farm which we are bound to make answer, but which we own frankly has not done so yet. When we took this farm in hand it had a bad character, owing as we found to the mismanagement of one tenant after another, who when corn was dear were able to make it answer under a bad system of culture, which when prices fell soon led to failure. No light or easy task is it to bring a heavy land farm of that size into good order with the land wet, poor, and foul. Manage as we might, a heavy outlay for drainage, cultivation, and manure must be incurred, and then we were handicapped by low prices for such corn as we were able to produce, so that much of the profits derived from other farms had to be spent upon this one. We intend laying fully half of this farm down to pasture. We have begun doing so this season, and we purpose to continue doing so upon that part of it farthest from the homestead. As a preliminary step the land has been carefully drained; we are also doing all we can to render it clean and fertile, for we hold that no land should be so laid down till this has been well done. We may subsequently have a flock of ewes there, but that is uncertain till we see if the pastures are sound enough in winter to carry sheep. If they prove at all doubtful we shall make as much hay as possible, and purchase crones or forward hoggets to fold on the pasture, and clear them out before the end of the year. There would be no difficulty about the sale of the hay, as the farm is near a good market for all kinds of forage.

The laying down of land either to permanent or temporary pasture enables us to reduce labour expenses, and therefore is worthy of careful attention. What propor-



**CROPPING A FARM.**

A FEW hours before sitting down to write this article we were asked by a prospective tenant for a farm half of

tion of any farm should be under a grass crop must altogether depend upon local circumstances; but in every case it is clear all that is possible must be done to keep down expenses. We have no sympathy with the cry of "the land for the people." Farmers should be keen men of business, only giving employment to just so many labourers as they are obliged to, and doing all they can to render their farms more profitable and to reduce labour in doing so. If by such action we drive labourers off the land to the towns, then let government take them in hand as it is bound to, for certainly farmers cannot afford to regard the labourers' welfare from a sentimental point of view, but it must be placed entirely upon a business footing.

#### WORK ON THE HOME FARM.

Heat and drought have told upon the corn so much that by the time this note is published harvest work will have become general in the southern counties. We began with a piece of Rye, which was followed quickly by a self-sown field of Winter Oats, a fine full crop, which was out and threshed at once, part of the straw being cut into chaff and the remainder put aside for thatching the other corn stacks, in order that Wheat straw may be reserved for sale. The chaffed Oat straw was put into a compact heap in a barn, a little salt being sprinkled among it to induce fermentation, by means of which the chaff becomes as savoury and high flavoured as meadow hay. Peas came next, and Spring Oats and Barley will follow on many farms where the Barley straw is short and the grain has ripened prematurely. As we use Oat straw for thatching the corn stacks, especial care is taken to build them with a high steep slope, so that rain may pass off from the thatch at once, as Oat straw soon becomes saturated if water remains upon it.

Pigs and sheep will go out upon stubbles to consume fallen corn immediately after the clearance of the crop, so that there may be no hindrance to ploughing as soon as possible after harvest. Especial attention should be given to this matter, for if fine weather continues every effort should be made to break up the land for autumn cleaning. If only we can do this really well a considerable saving will be effected upon corn-hoeing next spring, and much Charlock will be destroyed. Where land is badly infested with Charlock it is a mistake to plough deeply immediately after harvest, rather should we break up just enough of the surface to induce seed germination, and when a full plant of weeds is visible then stir or plough a little deeper, so as to induce more weed seed to germinate. No rule can be laid down for this work, rather must each field have the special treatment which it appears to require. Upon light land the use of harrows once or twice will disturb the soil sufficiently to work the seed into it deep enough to induce growth. Upon heavy land light iron ploughs answer best, but where such land has become very hard and dry steam cultivation is required to break it up before it is softened by autumnal rain. Couch Grass, Thistles, Dock, and Charlock are the four pests which we desire to eradicate, no matter how it is done, for to suffer such perennial and annual weeds to remain established in the soil is indeed bad practice.

#### IRON SULPHATE v. PARASITIC FUNGI.

THIS note may prove useful to agriculturists, for it is not unlikely (judging from the present state of the weather in certain parts of the country) that our farm crops may be attacked by parasitic diseases of a fungoid nature.

Having been the exponent for the use of iron sulphate as an antiseptic agent for various diseases which attack our farm crops (see my papers "Transactions Chemical Society" for 1882-3-4-5-6-7), I wish to state briefly that agriculturists will find it a sure and a cheap remedy for destroying most fungoid growths.

The fungi which infest farm crops are all built upon the same plan—viz., they are made up of hyphal filaments, which contain an external wall of a peculiar kind of cellulose, which I have named in a recent scientific memoir micro-parasitic cellulose, to distinguish it from the cellulose which is found in the higher plants. This micro-parasitic cellulose is chemically acted upon by iron sulphate, but not the cellulose of farm crops, hence the reason that the fungoid growths are destroyed by this agent.

In my papers already cited, and in one read before the Royal Society of Edinburgh on May 16th, 1886, I have shown, after a most careful investigation, that iron sulphate is a sure remedy for the Potato disease (*Peronospora infestans*), and the Wheat mildew (*Puccinia graminis*).

As I have said before, all the fungoid growths which attack farm crops are built upon the same plan, and for this reason I wish to draw the attention of agriculturists to what is being done by scientific men of well-known reputation with iron sulphate as an antiseptic on the continent of Europe, which entirely confirms my work.

The Vine is liable to be attacked by some 350 parasitic fungi in addition to the phylloxera! Happily our English farm crops have not such an array of deadly foes as the Vine. The Wheat has its mildew, its smut, its canker, besides such animal foes as the corn weevil, the wire-

worm, the corn moth, and the Hessian fly (*Cecidomyia destructor*), which has really "lauded in force" (according to Miss Ormerod) in these realms. The Potato has its *Peronospora* and its Colorado beetle, &c.

Coming back again to our scientific authorities who have used iron sulphate as an antiseptic, I may mention the following:—

1, Recently Dr. F. von Thümen mentions in his treatise ("Die Phoma-Krankheit der Weinreben verursacht durch die parasitischen Pilze *Phoma vitis* und *Phoma Cookei*") that he has used most successfully a 10 per cent. solution of iron sulphate for the destruction of *Phoma vitis* and *Phoma Cookei*, two fungi which attack the Vines of Austria and Hungary. Dr. Thümen's experiments were conducted at the Imperial Agricultural Station at Klosterneuberg, near Vienna.

2, M. Millardet employs one kilogram of iron sulphate in two litres of water for washing the stocks of Vines a fortnight before the shoots begin to start. Madame Ponsort in Bordelais uses a mixture of four parts of iron sulphate and twenty parts of lime for the same purpose (See Trouessart's "Microbes, Ferments, and Moulds," International Scientific Series, vol. 57, page 38).

3, Dr. H. Müller and others ("Biedermann's Contrablatt für Agricultur-chemie," 1883, page 630), have found a solution of one part of iron sulphate in two parts of water an excellent remedy for destroying *Peronospora viticola*, which attacks the Prussian Vines.

4, M. A. Guillaumont ("Biedermann's Contrablatt für Agricultur-chemie," 1883, page 272), states that a mixture of ten parts of iron sulphate, ten parts of wood ashes, and two parts of coal tar is a good specific for destroying the phylloxera.

5, The celebrated Professor of Botany at Würzburg University, Dr. J. Von Sachs ("Biedermann's Contrablatt für Agricultur-chemie," 1886, page 602), uses iron sulphate for trees and plants generally as a remedy for the disease known as "chlorosis in plants."

6, In my address at the opening of the School of Science and Art, on the 27th September of last year, I alluded to the fact that my friend Professor Conrad, F.C.S., had used iron sulphate successfully for destroying the mildew upon the Vines in the vicinity of Bordeaux. (See *Lincoln Gazette*, October 2nd, 1886.)

In the neighbourhood of Etton, near Peterborough, the crops of winter Beans have been this year a failure. Mr. G. W. Edgson, of Etton, an agriculturist of long experience, has kindly sent me a number of these Bean plants for inspection. They were about 7 inches in length. Mr. Edgson says in his letter:—"The roots of the winter Beans you will find are covered with small boils, which appear to be living upon the plant, and have kept the Bean plants in the stage you now see them. For the last few months the crop in this district has been a failure. Not having seen anything like it before I thought it would be interesting for you to see them." I found upon the roots of the Bean plants tubercular swellings, which are due to the growth of a parasitic fungus with extremely small spores. The mycelium of this Bean root fungus and also its spores are destroyed by iron sulphate. On treating the hyphal filaments of the fungus and its spores with a solution of iron sulphate upon a slide under the microscope one could see the perforation of the cellulose walls of the organism, exactly in the same way as I have so often observed in cases of microscopic fungi generally.

To conclude, Mr. Editor, I hope these notes may be of use to the farmer in helping him to allay the terrible ravages done to his crops by that "unseen mist of organic forms."—A. B. GRIFFITHS, *School of Science, Lincoln.*—(*Lincoln Gazette*.)

#### METEOROLOGICAL OBSERVATIONS.

CAMDEN SQUARE, LONDON.

Lat. 51° 32' 40" N.; Long. 0° 8' 0" W.; Altitude, 111 feet.

DATE.	9 A.M.				IN THE DAY.				Rain		
	Barometer at 33° and Sea Level.	Hygrometer.		Direction of Wind.	Temp. of soil at 1 foot.	Shade Temperature.		Radiation Temperature			
Inches.		Dry.	Wet.			deg.	deg.	deg.	deg.	In sun.	On grass.
1887.											
July.											
Sunday .....	24	29.957	65.9	61.4	S.W.	66.8	79.6	54.3	123.7	49.5	0.239
Monday .....	25	29.842	62.9	60.2	N.E.	65.2	76.1	58.3	113.8	53.2	—
Tuesday .....	26	29.741	65.5	59.7	S.E.	65.3	77.2	56.8	119.2	54.2	0.081
Wednesday .....	27	29.687	67.9	61.6	S.W.	65.5	76.8	62.3	124.8	59.1	—
Thursday .....	28	30.078	67.2	60.9	S.E.	65.2	76.8	56.2	125.0	51.9	—
Friday .....	29	29.977	69.8	63.2	S.W.	65.1	74.6	60.2	111.3	54.8	0.032
Saturday .....	30	31.125	64.6	59.0	N.E.	64.4	76.5	59.9	121.0	51.8	—
		29.917	66.4	60.9		65.4	76.8	57.9	119.8	54.2	0.452

#### REMARKS.

24th.—Fine and bright till about 11 A.M., the rest of the day cloudy.

25th.—Rain in the small hours, and cloudy day.

26th.—Variable morning, fine afternoon, cloudy evening; showers at night.

27th.—Showers early, variable day, fine evening.

28th.—Fine pleasant day, clouding over at times.

29th.—Fine early; overcast morning with slight showers; wet afternoon; fine and bright after 4 P.M.

30th.—Bright warm morning, and fair throughout.

Mean temperature about 5° above the average—a week of warm nights and pleasant days; little rain, except on the 24th.—G. J. SYMONS.





# COMING EVENTS

11	TH	
12	F	
13	S	
14	SUN	10TH SUNDAY AFTER TRINITY.
15	M	
16	TU	
17	W	Shrewsbury Show (two days).

## NOTES IN JERSEY.

**A**NY visitors to Jersey, be they gardeners or others, will meet with a courteous reception at the High View Nurseries by the proprietor, M. J. Le Cornu, and his son, M. Philip Le Cornu; and will find many things both instructive and interesting. High culture and cleanliness are the order of the day in this compact little nursery. Land in Jersey is too valuable for growing weeds upon, and every square foot of ground is profitably cropped. Men who pay £60 or £300 per acre for their land consider it is far too valuable for weed-growing purposes, and consequently keep it thoroughly clean, so that every atom of plant food the land contains may be utilised by those things which are likely to realise the most money. What must strike the most casual observer is the fact that every accessible yard of land that is not, or cannot, be cropped with anything else, is almost sure to be planted with Potatoes. Given a strip of land 1 yard wide and 10 or more yards long, on a steep hillside where it is impossible to get a cart or wheelbarrow, there you will find Potatoes planted. So in the High View Nurseries we find Potatoes growing between the rows of young fruit trees in the nursery quarters. Nor are the fruit trees impoverished by this process; clean, strong, healthy wood is to be seen in all the quarters, be they Peaches, Apricots, Plums, Pears, or Roses. The ground is highly manured before being planted with the trees, and a liberal dressing is given between the rows afterwards as occasion requires. The Potatoes quickly grow into money, give immediate returns for outlay, and keep the land free from weeds with little trouble. Were it not for the Potatoes weeds would be constantly extracting moisture and nourishment from the soil, and the same labour spent in planting, hoeing, and lifting the Potatoes would be required in keeping the land free from weeds, for which there would be no returns, but a direct, or indirect, loss. Fruit trees are the speciality at High View Nurseries, and M. Le Cornu is justly famed for the excellent quality of those he distributes, chiefly in Jersey, but also in England—some at Sandringham. Roses are also grown in great quantity, and each variety is planted in separate beds, so that when in flower the difference of the respective varieties in size, form, colour, and habit of growth is readily distinguishable.

The rare and very striking *Taxus japonica* is quite at home, and it is very strange that such a decidedly distinct and beautiful shrub is not to be seen in nearly every garden in this country; perhaps it is not sufficiently hardy, if not, it is a great pity. *Thuja Lobbi*, *Thuja dolabrata*, strikingly handsome, and *Picea Pinsapo* are magnificent specimens; and *Prunus Pisardi* will, ere long,

when better known, be more frequently seen in shrubberies and landscapes. M. Le Cornu, jun., takes an especial interest in Gooseberries, and in his collection we noted the following six kinds, all large, and very free bearing:—Beauty, Duke of Sutherland, Major Hibbert, Clayton, Drill, and Shiner. In discussing with this gentleman the question of stocks for Roses, he is of opinion that the best stock for *Maréchal Niel* is the *La Grifferaie*, and for other kinds he prefers the *Manetti*. He, in order to effectually overcome the suckers that are so apt to arise from that stock—to the no small bewilderment and ultimate disgust of the inexperienced—makes two incisions at right angles to each other, from beneath to right and left of the bud, and with one scoop with the point of the knife clears out the principal bud and the incipient buds on either side of it. This method, Mr. Philip Le Cornu assures me, is quite successful in disposing of all possible future suckers from the stem of the *Manetti*. To this young gentleman I am indebted for a close inspection of the nursery, and for an hour of very pleasant and profitable conversation, combined with great civility and courtesy.

Morley House, St. Heliers, is the residence of Mr. Bashford, a gentleman who, perhaps, grows more Grapes and Tomatoes under glass for Covent Garden Market than any other individual. An artist by profession, some seventeen years ago he commenced growing Grapes as a pastime, and from a mere pastime has arisen a gigantic wholesale fruit trade. The faculties required and developed in a true artist have most appropriately and successfully been brought to bear upon the production in immense quantities—and without a single failure, apparently—of highly finished Grapes and Tomatoes. The total area of ground occupied by the houses, borders, and walks is about fifteen acres, and the area of ground actually covered by the immense glass structures is supposed to be eight acres. Your readers will not be able to form a very correct idea of the vast number of Vines and Tomatoes planted underneath these eight acres of glass, nor is it possible for me to give them a correct idea of the same by any word-painting; and far less is it in my power to do justice to the absolute health, cleanliness, vigour, and fertility of Vines and Tomatoes alike. I believe that during the past twenty-three years I have seen the best examples—both in quantity and quality—that are produced in this country, and truth and justice compel me to say that I have seen no Vines or Tomatoes that have surpassed in health, vigour, and productiveness the Vines and Tomatoes at Morley House. “Ah!” someone will perhaps say, “very likely Mr. Bashford has a park or some meadows of old pasture that he can cut up as he likes; and he will have stacks of turf, with all the best of the manures intermixed, and so there’s no wonder at his having good Grapes and Tomatoes.” Mr. Bashford has nothing of the kind—not one stack of soil; furthermore, he told me he used nothing but the alluvial soil in the neighbourhood, combined with such artificial manure as he found most suitable for Vines and Tomatoes, and which had cost him a considerable amount of time and money in analysis and experiments. It is also very apparent to the most superficial observer that there has not been any specially made borders in the majority of cases, if not in all cases. This alluvial soil is a red and stiff loam, neither too friable nor too tenacious, but exactly of the mechanical nature the Vine and the Tomato delight in; and the appearance of both of them testify unmistakably that the chemical nature of it is right, either naturally or artificially.

Nearly all the houses are span-roofed structures, and the Tomatoes are planted in rows across, leaving a path down the centre, and trained vertically towards the roof, supported by stakes. Sufficient space is left between the rows for a workman to pass between them, and thus easily be able to attend to the requirements of each plant. The first vinery we entered is a lean-to, 630 feet in length, and is devoted to early Grapes—Black Hamburgs principally, all the fruit being cut at the time of my visit, 16th July. This house was planted seventeen years ago, and after bearing heavy crops for that period the Vines were cut down, and have again developed canes of superior quality and regularity throughout the house. As an illustration of the express speed with which Mr. Bashford conducts his operations, I may mention that the next house we enter is a span-roof, 350 feet in length by 44 in width, and 20 in height; Mr. Bashford commenced to build this house last March. on the 16th of July the body of this house was filled with grand Tomato plants in full bearing—hundred-weights of fruit being picked out of it twice or three times a week; and young Vines planted at the sides had nearly reached half way up the roof of the house. The Tomato chiefly grown is a hybrid between Trophy and Conqueror; the bulk of the fruit is of beautiful form and appearance, and they vary from half a pound to a pound and a quarter in weight.

Of all the glass structures on the premises only one house is devoted to other than Grapes and Tomatoes, and this one structure is planted principally with Cucumbers and several Melons. Wonderful as is Mr. Bashford's success with Grapes and Tomatoes, he is not less so with Cucumbers and Melons. Cucumbers of large size were hanging in that house by hundreds; and Melons—Hero of Bath—are represented by specimens from 6 lbs. to 7½ lbs. in weight. The variety of Cucumber grown is called Star of the West.

The next house is 104 feet in length, and is filled with luxuriant Vines, each plant carrying an average of ten bunches, and each bunch averaging 2 lbs.; all Gros Colman. The Vines are planted 2 feet 4 inches apart, and as the house is a span-roof your readers can try to picture it to themselves. The next house we enter is similar in all respects to the above; but we now come to a span-roofed house 890 feet in length, and this is entirely planted with Gros Colman, every Vine being in similar condition to those previously specified, and bearing equal quantity and quality of fruit; this alone will be a sight in September and October worth going hundreds of miles to see. It must not be supposed that because these structures are of such immense length that therefore they must be low, narrow, squat-looking places; far from it, they are substantially built, wide, and lofty houses; such as would do credit to the best private gardens in the kingdom.

Now we enter a house parallel to the last, but not quite so long; it is between 700 and 800 feet long, and is occupied entirely with Tomatoes. But there have been two crops of Potatoes gathered out of the same house previously, one crop at Christmas, and the second crop in March; and in July the house was filled with Tomatoes in full bearing. That is the way to make market gardening pay. The Tomatoes are planted in rows 3 feet apart, and the plants are 2 feet 3 inches apart in the rows.

Another house is entirely devoted to Gros Colman, and on entering house after house of this variety—seeing it growing literally in tons—it is not difficult to understand how it comes that Covent Garden Market is kept so well supplied with this variety of Grape, especially when we remember that Mr. Bashford is only one of many who

“go in” for this variety for market purposes. Another house, between 700 and 800 feet long, is at present occupied with Tomatoes, but it is intended to devote it entirely to the production of Muscat Grapes; and seeing that Muscats realise such a good price from Christmas to the end of April, it is likely to prove a very profitable house.

These notes are the result of observations taken during a hasty inspection of this remarkable establishment; but to do it full justice would require an entire number of the Journal, a day's careful inspection, and a pocket-book full of notes; and as I have already encroached considerably upon the valuable space of the Journal, I will close these notes by remarking that Mr. Bashford provides as good and efficient accommodation for his Grapes when bottled as he does for their production. If my memory has not failed me, the Grape-room will hold about 18,000 bunches of Grapes; and as I have previously stated that the average weight of the bunches is about 2 lbs., your readers can compute for themselves how many tons of Grapes there are in the room when it is full.

Immense boilers are used for the purpose of heating the houses when necessary; and the “Keith” boiler has a mile of piping attached to it. Water is pumped by steam power to the top of a water tower, from whence it is distributed through all the houses; and it is very evident that it is used with no niggardly hand; and had I required any evidence to convince me that Vines in suitable soil, and with proper natural or artificial drainage, required an abundance of water, that evidence would have been unmistakeably found at Morley House.

I am much indebted to Mr. Bashford for his kindness in permitting me to see his magnificent graperies and tomateries—if I may coin a word—and also for his courtesy in personally conducting me, and the pains he took to show me everything likely to be of interest.—  
J. UDALE, *Elford, Tamworth.*

#### STRAWBERRIES IN 1887.

I WAS pleased to read the remarks at page 76 on flavour of Strawberries. It is also satisfactory to read about the good qualities of Loxford Hall Seedling, raised by me about fourteen years ago. I raised about 300 seedlings, the result of careful hybridisation, and Loxford Hall was the only one sent out. I would not like to have my name attached to a bad variety of a flower or fruit, and yet when one reads the remarks of some gardeners it seems that this Strawberry is a failure. One of our leading gardeners wrote in a contemporary that Loxford Hall Seedling was not worth growing. He had tried it for three years, and it never produced a flower. “S. C.” describes it very well. The plant was raised from Frogmore Late Pine, crossed with a continental variety named La Constante, popular at the time. It is our latest Strawberry, produces a dwarf plant, but bears very freely. I have never seen a plant of it that did not bear fruit freely.

Nearly all our Strawberries have been inferior this year. The excessive heat dried up the juices before the fruits were ripe. We place round each plant some sprays cut from the tops of the Pea sticks; the fruit hangs over these, and never touches the surface of the ground. None of it is eaten with any of the numerous creeping things which prey upon fruits lying on the surface of the ground, and it ripens perfectly all round. This season it turned up in a way it has never done before during a period of twenty-five years. They were twice drenched with water, as well as being mulched with decayed manure to prevent evaporation. We still grow Black Prince and Keens' Seedling as our best earliest varieties, followed by President, Sir Joseph Paxton, and W. F. Radclyffe. The last-named we grow as being more robust in constitution than British Queen. Frogmore Late Pine and Loxford Hall Seedling are our latest. A new variety sent out by Messrs. Veitch of Chelsea, named Waterloo, promises to be distinct in character, and it is also very late. The fruit is of the largest size, excellent in flavour, and of a reddish purple colour. We also tried Laxton's King of the Earlies. It promises to be a free-bearing variety, but was not any

earlier than Black Prince, much like it in plant and fruit, which is of a better flavour. Pauline is, I think, the best variety to grow out of doors to produce early fruit. It ought to be planted out on rich ground on a border well exposed to the sun, and sheltered from the north or east by a wall or fence. It was about ten days earlier than King of the Earlies or Black Prince, but those two were in the open ground. The fruits of Pauline are of the largest size and of excellent flavour.

I believe the best Strawberries are produced from young plants, and prefer to make a fresh plantation annually. The ground must also be trenched up to 18 inches or 2 feet deep, and plenty of good manure should be dug in or trenched in. I like to place a layer in the bottom of each trench, and another layer about 6 or 9 inches below the surface.—J. DOUGLAS.

## NOTES ON PINKS.

### WHITE PINKS.

I do not think it is generally known that there are two varieties of the common white garden Pink in cultivation, the one being very much whiter than the other, though not on that account any the prettier, the soft shade of yellow present in the more common variety being very attractive. Now that Mrs. Sinkins has established a character for its very free-flowering and perpetual habit, while its scent is delightfully sweet, and the soft yellowish tint detected at the base of its rather loose petals is most charming, there may be a danger of the older varieties being displaced. But to discard the one for the other would not be wise, as the two are essentially distinct in almost every particular. Last year I had plants of a new variety named Mrs. W. Welsh from Messrs. Dicksons & Co. of Edinburgh. This they considered superior to Mrs. Sinkins. But though it is of the purest white, and in that respect might be considered of superior merit, they are in other respects very distinct. Mrs. W. Welsh is a lovely sort, free-flowering, and, as already indicated, pure white, and may be safely grown on its own merits as a sterling variety. But for general usefulness, sweetness, and beauty, I still think Mrs. Sinkins has nothing to fear. Both are easily propagated, cuttings striking root if inserted on borders without protection. Later on, handglasses blurred with sand are most suitable for insuring a rapid strike, though it is well to remember that the earlier the cuttings are taken the better, and the more floriferous will be the plants in the ensuing summer. All Pinks do best as young plants, and the soil in which they are grown should be well enriched, though the manure need not be deeply buried. The common white Pink is most easily propagated in September, when many roots are formed on the stem; not too large pieces broken off, and planted where they are to flower, do very well.

### LACED PINKS.

There are no sweeter flowers than these, and though generally grown as a florist flower, the laced Pink is most suitable for growing with much less attention. Strong sorts should be chosen, and I rather prefer the heavy laced varieties to the lighter flowers, but any of them are fine. The same plant will bloom year after year, but young plants are much to be preferred, the blooms being much larger, and I think sweeter, from young plants than from old ones. Cuttings—pipings is the technical term—should be taken as early as possible, and they root well in the open border, and with increased celerity under the protection of bellglasses. The buds alike of Mrs. Sinkins, Mrs. W. Welsh, and these should be thinned, the flowers being much superior and more useful when cut.

### ANNE BOLEYN PINK.

I do not often see this old variety. Perhaps the small return of bloom it makes to the grower has caused it to be thrust into the background. To those who do not grow it or know it, Anne Boleyn can well be recommended, it is so deliciously fragrant. It may be propagated from cuttings, but it is much better to layer the number required for plants, as these are so much stronger, and the only way to increase the number of flowers on an individual plant is to get sufficient strength to secure a strong flowering stem capable of producing blooms at every joint. Those who are fond of sweet-scented flowers should certainly include this among those they grow. We cultivate a large number of other varieties, but the above are the best, many otherwise good varieties being sadly wanting in fragrance.—B.

## CARBOLIC SOAP AS AN INSECTICIDE.

No doubt there are many of your readers who are pestered with earwigs, caterpillars, blight, &c., on their plants and trees, and to all of whom an efficacious remedy would be a boon; permit me, therefore, to state my experience with substances that seem to me to be a sovereign

remedy against all such destructive garden pests. The plants are singularly free from blight and insects in my garden, excepting earwigs and caterpillars, both of which abound, but a friend of mine has had his wall fruit trees annually attacked by the American blight, and his Currant bushes with the aphides that cause the leaves to curl and cockle up. As a remedy for the blight I tried last year petroleum in water, but it was tedious work, and, moreover, this year some of the trees attacked have completely decayed; therefore this year I determined to try the effect of carbolic soap, knowing full well that that body is a powerful antiseptic and destroyer of all germs and insect life. I therefore dissolved a quarter of a pound of carbolic soap in a gallon of water, and then with a common paint brush washed all the stems, branches, and axils wherever the American blight appeared. If it was very thick I rubbed the brush on a piece of the soap held in my other hand. I was surprised to see with what readiness the blight was brushed off the trees. All the white woolly portion and the gummy red bodies were washed off completely. I next tried the effect of the soap solution on the Currant bushes, brushing the liquid into the axils and under the leaves wherever they were curled up with the insects. The fluid acted marvellously, and since I washed them, a week ago, the shoots have started fresh growth, whereas before the growth was checked by the presence of these aphides.

I next tried the effect of the soap in my own garden, for the earwigs and caterpillars have made a wretched appearance of the Sunflowers and Dahlias I have in bloom. I first tried the effect of painting several inches of the flower stems with the soapy water, but I found that had no effect, for both earwigs and caterpillars crawled over it. This was not encouraging, but finding that the fluid did destroy them I placed a few caterpillars and insects in a saucer with a little of the soap solution, and in ten seconds the caterpillars were dead, and in twenty seconds the earwigs were dead. I tried the effect of dropping some of the liquid into the flowers round the base of the petals where the earwigs seem to secrete themselves most. The effect of this was to preserve the flowers, for neither yesterday nor to-day do the flowers show any signs of having been gnawed, and, moreover, to-day I picked out a few dead earwigs from the base of the petals, plainly showing that the soap solution I had placed there had killed them. From these facts I shall try the effect of the soapy liquid on more delicate flower buds, using a toy squirt to deposit the fluid in the flower buds. The flowers themselves seem apparently not affected by the liquid. Perhaps some of your numerous readers will try this carbolic fluid—of course a solution of carbolic crystals would be stronger than one made from the soap—and report their experience. From the few facts I have gathered it seems to me to be a most effectual eradicator of garden pests.—H. C. STANDAGE.

## PYRETHRUMS AND DELPHINIUMS.

In most localities Pyrethrums will be past their best, and should have the old flower stems cut away without delay if a good supply of bloom is required again in the autumn. After this is done, if the weather continues dry, give the plants a thorough soaking of water, or liquid manure in a weak state, and then mulch the surface to prevent evaporation. Short decayed manure, such as the refuse of Mushroom beds, old tan, cocoa-nut fibre refuse, leaf mould, or even short grass, are all excellent for the purpose, but any of the former have a neater appearance than the last. This treatment will have the effect of pushing these plants into fresh growth, and after the ground has once been well soaked by rain they will grow luxuriantly, and produce again an excellent crop of flowers.

If it is necessary to increase the stock of any of the varieties this is a capital time to do so. After a good watering they can be lifted and divided into as many portions as there are flower stems, each portion being potted singly in 2-inch pots in any light sandy soil. Place a little sand about the stem of the portion inserted. If well watered, kept close in a frame, and shaded from the sun, young growths will quickly issue from towards the base of the flower stem. Although propagation can be effected successfully by this method, we prefer to see the young growths appearing above the ground before lifting and dividing. With new growth fresh roots start into activity, and very frequently each portion can be taken off with a few of these attached, and then, with close moist treatment, they quickly become established.

When well rooted it is an excellent practice to place them into 4 or 5-inch pots, and allow them to remain in these during the winter, to be finally planted out during genial weather in spring. Perhaps the plants make greater progress if planted out from the small pots directly they have been well established and hardened. But the great drawback to this system is the liability of the plants to be destroyed by slugs, which are particularly fond of the young growths. Therefore it is safer to keep the plants in frames through the winter, and place them out in spring after they have well started into growth.

Delphiniums—that is, all the early flowering varieties, will be past their best, except in northern localities. However, as soon as they reach this stage, unless seed is required, their flower stems should be cut away, and in a short time fresh growth will start from the base, which will result in another fine crop of flowers in autumn.



If this operation is delayed, and the plants allowed to seed, they have not time to flower a second time, but produce only towards the close of the season a quantity of soft growth that is certain to be destroyed by early frosts. If necessary to increase the stock of any varieties, it can be done after flowering just as well with these plants as with the *Pyrethrums*. A usual practice is to divide the crowns in spring when regulating the plants in the beds and borders in which they are grown. The result of this treatment is poor growth only the first season. When divided after flowering, even when planted outside again, they become established before winter, and start vigorously into growth the following season. If the plants are cut up very small we prefer to place each piece singly in 4-inch pots, according to the size of the piece, establish them in frames, and then turn them out. We have had plants treated on this principle that have produced spikes of bloom in autumn after planting them out, and the following spring have produced spikes fully 5 feet high. Any that show signs of late-flowering when ready for planting out can be transferred into larger pots, and used with much effect in the conservatory late in autumn, when blue of any description is invaluable for associating with other coloured flowers.—G. N.

### THE HORTICULTURAL CLUB.

ACCORDING to their annual custom the members of this Club had their annual excursion on Tuesday week, and everything passed off with the greatest amount of pleasure to all those who shared in it. Horticulturally speaking, it was not so remarkable as some of the excursions of previous years, for it is hard to meet with places like Lord Eversley's and Baron Schroder's every day. But in many respects the day was unique, and afforded thorough enjoyment to the large party who met together to have a good day's outing.

The members and their friends met at the Charing Cross station of the South-Eastern Railway at 10.50, and proceeded in a saloon carriage at 11 o'clock to Tunbridge Wells, which was reached at 12.25. The brakes were in waiting, and a start was made for Eridge Castle, the beautiful seat of the Marquis of Abergavenny. The drive through the park was exquisite, affording fine views of the wooded country, also the Wells. Here they met a kindly reception from the skilful gardener, Mr. Rust, and a hurried view was taken of the pleasure grounds and gardens, some fine specimens of the Tnlip Tree being especially noted. Lunch was here taken. The drive through the park past the Eridge rocks was new to most of those forming the party, and their admiration was very strongly expressed. Every one who knows them is aware of their exceeding beauty and grotesqueness, and how strongly they impressed them when first seen. From Eridge a long drive of about seven miles was taken through a most lovely country, by the pleasant rural village of Groombridge, and on to Penshurst Place, the historical residence of Lord De Lisle and Dudley, associated with so many eventful periods of English history, and containing so many relics of days long gone by. Here the old house was visited and the garden which is still kept up in the old Dutch style in fashion in the days when Penshurst was in its glory. It had been intended to visit Redleaf, but it was another instance of trying to drive six omnibuses abreast through Temple Bar, and it had to be given up. A pleasant drive to Tunbridge Wells, where dinner was prepared at the Hotel Wellington, on Mount Ephraim, the party leaving for London at 8 o'clock, some few remaining behind for down trains, &c. There was but one opinion about the success of the day, for a more enjoyable one could hardly have been spent. The weather was glorious, a good shower of a day or two previous had laid the dust, there was abundance of light cloud to temper the heat of the sun, and, indeed, in the evening when some of us were sitting outside the hotel, it was quite chilly. And thus another of the very pleasant trips of the Club was brought to a successful issue.—D., Deal.

### HANGING BASKETS FOR THE COOL FERNERY.

HANGING baskets are to a fernery, either warm or cool, what climbers are to an ordinary conservatory; they are necessary accessories without which the place loses a great deal of its beauty and attraction. But while in conservatories or winter gardens, either the climbers used may be of many hues, or the baskets may equally be filled with a mixture of foliage and flowering plants of all kinds, or exclusively with foliage plants these, in the fernery are usually made up with Ferns and a few suitable plants of drooping habit, as such conditions as the moist atmosphere and the comparatively subdued light, so beneficial to the growth of Ferns, are not at all conducive to the production of flowers. The general complaint, as we have repeatedly had the opportunity of noticing, is that for the cool fernery the number of Ferns adapted for that special use is very limited, although to a certain extent correct, as there are undoubtedly many more kinds of Ferns of drooping habit suitable for the warm than for the cool house. The statement, however, is greatly exaggerated, and requires correction, for there are at the very least a dozen sorts which, in a temperature averaging about 45° in winter, and occasionally falling lower, will succeed admirably. These are quite sufficient for the adornment of many baskets, as many as we really need have in a fernery, the dimensions of which are not out of the common, for, when used singly, a dozen baskets may with these be made up, and all of them differing from one another, whereas by using several

different kinds together, and making what is commonly termed mixed baskets, the quantity of variations and the production of baskets of entirely different appearance is still greatly increased.

According to the requirements and the dimensions of the fernery, the Ferns used for basket planting for the cool house may be divided into two sections—the strong-growing kinds, by far the most numerous, being especially useful for spacious and lofty constructions, while those of shorter growth, but equally hardy, are particularly adapted for the fernery of smaller dimensions. Of the various kinds generally used for baskets of a large size, *Nephrolepis tuberosa*, a handsome Fern, whose fronds, produced in great abundance, average about 3 feet in length, occupy a most prominent place, on account, no doubt, of its gracefully hanging habit and the ease with which it is grown, the more so that, provided it be well supplied with water at the roots, it is not at all particular as to its soil, growing as well in half-decayed moss as it does in the best peat or mixed soil.

*Woodwardia radicans*, a splendid Fern, native of Madeira, though not so commonly used, is, however, one of much more imposing appearance than the one just mentioned. Its bold, massive, yet elegantly drooping fronds, which vary from 4 to 6 feet in length, are of a particularly light green colour, being totally distinct from those of any other Fern. They are produced from a decumbent rhizome, and rendered still more effective by the young plants, which are produced at their apex, sometimes singly, but more often three or four at the end of each frond, and by which means the plant is readily propagated. All that is required for its propagation is either pegging down the tip of the frond on to a mossy or any other porous material of a constantly moist nature, or the cutting of the said part of the frond and its insertion into a little peat and chopped moss kept evenly moist, and in which its numerous roots are produced in a very short time. The crested form of this species, *Woodwardia radicans cristata*, which sometimes is also met with in collections under the name of *Woodwardia Browni*, but the common appellation is much more proper, is equally well adapted for growing into baskets; but its fronds, well crested, and highly viviparous, though perhaps more abundantly produced, are shorter, and of a little stiffer character, the habit of the variety being thus less elegant than that of the species from which it is issue. Nevertheless it makes a very handsome basket, as does also *Woodwardia orientalis*, a grand Fern of Japanese origin, with fronds averaging about 4 feet in length, very broad, and in their youth of a beautiful metallic colour, whereas in the autumn quite a peculiar and very uncommon appearance is produced by their upper surface being thickly studded all over with little bulbiform plants which, when detached, form the readiest means of reproduction.

Of the several *Aspleniums* suitable for the cool house, and adapted for growing in baskets, *A. biforme* is the most useful, as well as the most elegant. This Australian species produces from a decumbent or slightly creeping rhizome, fronds which, for elegance, have very few equals. They frequently attain 3 feet in length, and are more finely divided than those of any of the above described Ferns. Their particularly graceful arching habit renders this species eminently suitable for basket purposes, as the quantities of young bulbiform plants produced all over them, but most particularly at the end of each of their pinnae, is also a permanent source of attraction. Next to *A. biforme*, the most useful basket Fern for a cool house is undoubtedly *Asplenium flaccidum*, a species from Tasmania and New Zealand, with foliage of a peculiarly bright shining green colour. Its lovely fronds, which are not so finely cut as those of the species previously described, are only bipinnate, of a leathery texture and pendulous habit. They average about 3 feet in length, and like those of *A. biforme*, *A. bulbiferum*, *A. Colensoi*, and others, they get completely covered with young bulbils, which are most readily used for the propagation of these species. *Polystichum angulare proliferum*, although of British origin, may also claim to be one of the most useful of all basket Ferns for the cool house; its beautiful fronds, which are produced in great abundance from a central and very scaly crown, are very finely divided, of a character nearly as light as that of the Lace Fern itself. They average about 24 inches in length and 6 in breadth, and their base is completely covered with small bulbils, which are used for the propagation of that useful and decorative variety.

If we now turn our attention to the Ferns which may with advantage be used for baskets of smaller dimensions in the cool house, we find, as one of the most useful and most elegant species, the lovely *Davallia Mariesi*. It is a very elegant Japanese Fern of dwarf habit and very free growth, with fronds more finely divided than those of any of the other *Davallias*. Its slender silvery flexuose rhizomes spread freely in all directions, and its numerous fronds thence present an enduring globose mass of verdure.

Although it may be propagated from spores, this pretty species, like most of the others belonging to the same genus, is generally increased by the division of its rhizomes, which should take place at any time from February to April. Very elegant also for baskets in a warm house is *Davallia tenuifolia* Veitchiana (fig. 14, kindly lent by Messrs. J. Veitch & Sons); it has slender drooping finely divided fronds, and much more graceful than the species.

Next comes the charming little *Pteris scaberula*, in itself a real gem among Ferns, but related to the ordinary *Pteris* or Ribbon Fern, or to the common Bracken, *Pteris aquilina*, only by its fructification, the disposition of which is similar to that of these well-known species; but there ends all the likeness, for this lovely little New Zealander, of dwarf stature, which has proved perfectly hardy in Cornwall and Devon, where it stands without any protection,

which extend a long way, the entire covering of a basket of small dimensions is a work of comparatively short time. The South African *Adiantum venustum* is a species equally well adapted for growing in baskets in the cool house, where its pretty, though somewhat fragile-looking fronds, about 12 inches long, are particularly interesting on account of the contrast formed by their pale colour with that of most other Ferns surrounding it. Our native Maiden-hair Fern (*Adiantum Capillus-Veneris*) and several of its varieties, may also, and indeed are frequently used with great success for basket growing, the common species being the one most generally used, partly on account of its being more plentiful, but also because its scaly rhizomes, on which its leathery fronds are produced abundantly, extend more rapidly than those of any of its varieties. *A. Capillus-Veneris magnificum*, however, is a very quick grower,



Fig. 14.—DAVALLIA TENUIFOLIA VEITCHIANA.

and in other counties where it remains uninjured outside, provided that its rhizomes be protected by some litter or a few old leaves, is provided with fronds of a cheerful green colour, and as finely cut as those of the Lace Fern itself. They are lanceolate in outline, about 12 or 15 inches long by 5 inches wide, and produced in great abundance from very slender creeping rhizomes, which rapidly cover all the surface of the basket, and make it a most elegant mass of foliage. Although it may be increased from spores, that remarkable and totally distinct species is also generally propagated by the division of its numerous rhizomes, which are provided with roots either developed or rudimentary on their whole length.

Among the species of *Adiantums* which are adapted for basket, and which succeed well in a cool house, the prettiest is undoubtedly *A. assimile*, a native of Australia and New Zealand, with small slender fronds which vary from 6 to 10 inches in length, and are particularly attractive through their bright green colour. This species, being provided with very small or rather slender rhizomes,

and its fronds, when the plant is in good health, and placed under favourable conditions, may be compared to those of the glorious *A. farleyense*, which they resemble in size if not in beauty. Though a slower and more slender grower, *A. Capillus-Veneris cornubiense* also deserves to be grown in the same way, where it shows to great advantage its prettily lacinated fronds of a peculiarly bluish tint; while *A. Capillus-Veneris Mariesi*, being a much more robust grower, is more adapted for baskets of a medium size, as its fronds of a pale pea-green colour frequently attain 20 inches in length.

In planting baskets, the principal object to be kept in view is elegance. Nothing looks worse than a heavy massive grouping of plants, especially when these are intended to be seen from below; and in addition to the Ferns enumerated above, the introduction, as a central plant, in baskets of large dimensions, of a light Palm, such as a *Phoenix reclinata*, or of a tall, loose-growing, *Pteris Ouvrardi*, will be found a great improvement, affording a pleasant

and striking contrast. The proper way to fill a basket is to first line it with a coating of green moss, against which should be firmly pressed such pendulous plants as *Ficus repens*, *Tradescantia zebrina*, or the pretty *Lygodium scandens*, a Japanese Fern, which should be allowed to hang in festoons. These drooping plants should be loosely pinned to the sides, which they will rapidly cover entirely. Then the Ferns should be planted in, but in such a way as to overhang the sides of the basket all round, leaving between the foliage a comparatively open space, allowing for the growth of all the plants, which, if proper care is bestowed upon them in the way of shading and watering until sufficiently established, will, in a season, form an elegant and highly decorative mass of foliage, filling up in a most effective manner the gap naturally existing between the pot plants and the roof of the house, a result which it is quite impossible to obtain by any other means.—THEO.

## YORKSHIRE ASSOCIATION OF HORTICULTURAL SOCIETIES.

### ANNUAL MEETING AT BARNSELY.

The third annual meeting of the above Association was held at Barnsley on Monday, at the assembly place of the Barnsley Paxton Society, the "Queen's Hotel." The members of the local Society had done all that they could to make their friends from other towns welcome. In fact, that word was conspicuous among the decorations of the room, in which were also exhibited a number of choice foliage plants lent by various members of the Society. Among those present we noted the following:—Messrs. Smith and Hemming, Leeds Paxton Society; Messrs. H. Oxley (Vice-President), T. Garnet (delegate), H. Chapman (delegate), A. Willis (Treasurer), Mr. G. Ramsden (Librarian), B. Whiteley, W. Calvert, H. Green, E. T. Oxley, E. Storr, J. Fletcher, T. R. Preston, J. Spurling, H. Hardman, Hy. Lupton, and H. Bennett, Wakefield Paxton Society; Geo. Armitage (President), and Chas. Goff (Vice-President), Morley Paxton Society; W. Butterell and H. Middleton, Rotherham Paxton Society. Visitors: Messrs. T. Gartery, A. Taylor, J. Nicholson, and V. Mann. Messrs. Cook and H. Slaney (Sheffield, Hallamshire), H. Butterill and H. Middleton (Rotherham). Among the members of the local Society present were Messrs. W. Henshall (President), W. Hoey, S. Ballinger (Secretary of the Association), Batley, Hall, Lockwood, Rideal, Hirst, Lawton, Hampson, Wright, Levitt, &c.

On the motion of Mr. Henshall, seconded by Mr. Butterill of Rotherham, Mr. H. Oxley of Wakefield, one of the trustees, took the chair. He remarked that he had been called upon at a moment's notice to take the chair, and had he known that he would be called on to fill that position he should have been prepared with some remarks on the Association, and more fully than he could do under the circumstances. He had held the official position of trustee, but so far his office had been an honorary one, and it seemed that such would be the case with regard to the present meeting. He certainly did take an interest in the Wakefield and other Paxton Societies, and as a vice-president of the former he wished all such societies success. He was glad to see so many representatives of the various societies present, and he hoped they would go on and prosper. They had not done a good deal during the year, and it was thought they need not be too hasty. No doubt the report would show that about as much support had been given to the society as was anticipated. It was not the quickest growth that makes the firmest wood; but he was glad to say he had heard of societies that were anxious to join them. The energetic secretary would read them the minutes of the last committee meeting. Mr. Ballinger did so, and also a letter of apology from Archdeacon Blakeney, who said that he had to be in London on the day of the Association's meeting or otherwise he would have been with them. The report was then read by the Secretary as under:—

"The last gathering of the members of the Association took place in August last, at Sheffield, under the auspices of the Sheffield and Hallamshire Gardeners' Mutual Improvement Society, which society was highly complimented by the visitors for their sociable entertainment, and for the excellent arrangements of the day's programme. The evening lecture entitled, "A Chat about Hardy Herbaceous Flowers," by the Rev. A. R. Upeher, of Sheffield, which was illustrated by an extensive and beautiful display of specimens, proved very interesting and instructive, and was much appreciated by the members present. The day's programme included a visit to the celebrated nurseries of Messrs. Fisher, Son, & Sibray, at Handsworth, which place it is regretted but few members were enabled to reach, owing to the difficulty in obtaining conveyances, all of which appeared to be engaged in carrying visitors to the Yorkshire Agricultural Show, where the majority of the members spent a very pleasant afternoon. The Association, still in its infancy, has made encouraging progress during the past year. Increased interest in the Association and its work have taken place, and the close relationship and natural social feeling which exist between the societies afford just and abundant proof for the future greatness and prosperity of the Association. During the past year two council meetings have been held. At these meetings earnest work has been done with the special desire to carry out the objects which the Association has taken in hand. For the more effectual working out of these objects necessary alterations in the rules have been made. Other matters have had careful study, particularly the holding of quarterly meetings, the gardeners' registry, the question of permanent

secretary, and the interchanging of essays and lectures. Efforts have also been made to increase the membership of the Association by bringing before other societies in Yorkshire the great advantages attached to the combination. Some of these matters, not yet perfected, will, during the coming year, claim your serious consideration, and at future council meetings engage just attention. By the accompanying balance-sheet it will be seen that the financial position of the Association has considerably improved, and shows a saving on the year's working of £3 2s. 2d., and raises the total amount of funds in the Association to £6 8s. 9d. The number of societies in the Association at the present time is six, with a membership of nearly 800. The Council take this opportunity of expressing their sincere thanks and best wishes to all who have in any way rendered beneficial assistance towards the progress of the Association, and conveys the same to the members of the Association generally."

The Chairman moved the adoption of the report and balance-sheet, and which he would ask Mr. Hemmings of Leeds to second. In the first place they were all sorry that the Rev. W. W. Kirby, their respected President, was unable to be present. The report and balance-sheet were both very satisfactory. In some of their objects on behalf of the craft of horticulture they had been able to succeed, and they hoped to continue to do so and to a greater extent. It had been a pleasing matter to him to notice what a hearty welcome had been given to the Association, and he was sure they were very much obliged to the Committee. Mr. Hemming seconded. He remarked that he could fully endorse everything which was stated in the report, and bear testimony to the way in which the matters of the Association had been dealt with. Mr. Garnett of Wakefield said it gave him great pleasure to support the resolution, but they considered the business-like way in which Mr. Ballinger had drawn up the report, they could not but express their thanks for the way in which it had been carried out. They must congratulate Barnsley on the way they had entertained them. No doubt in the future they would see the Association consolidated and doing better work than at present, though he thought they hardly ought to complain now. Mr. Cooke (Sheffield) likewise supported the resolution. He was glad to see rather a larger amount in the Treasurer's hands. He must apologise on behalf of the Sheffield Societies. It was a great matter for regret that there was not one of the Vice-Presidents of the Society present. Mr. Ball of Sheffield was unable to be there. That gentleman was one of the most successful exhibitors at the Handsworth Show, and hence he was detained in that district. He was in the habit of getting big prizes when he exhibited, too. The Barnsley Society must be congratulated on the very able statement which had been read that day. The report and balance-sheet were then formally adopted. Mr. Hall, Barnsley, proposed that Leeds be the next place of meeting, and Mr. Cooke seconded. The Chairman: I suppose it is the wish of the Leeds Society. Mr. Cooke replied that at the last meeting they entertained the idea. Mr. Hemming said there was a strong feeling in favour of the next meeting of the Association going to Leeds; and the Chairman expressed himself in the same way. Consequently it was agreed that the meeting will be so held. The election of officers was then proceeded with. On the suggestion of the Chairman the election of President was allowed to stand over for the consideration of the Leeds Society. Mr. W. Hoey (Barnsley), and Mr. Franklin (Leeds), were elected Vice-presidents. Messrs. H. Oxley and J. Garnett (Wakefield), were appointed Trustees, and Mr. Crossley, Treasurer of the Leeds Society, was appointed Hon. Treasurer. It was resolved that the duties of Hon. Secretary should be filled by the forthcoming Secretary of the Leeds Society. Mr. B. Whiteley (Wakefield), moved a vote of thanks to the retiring officers. He was sure that, in the first place, they were indebted to Mr. Oxley, not only for taking the chair, but for the way in which he had given his valuable advice to the members of the Society during the past year. If there was one man who had taken an interest in the Society that one was Mr. Oxley. He was bound, too, to convey the thanks of the Association to Mr. Ballinger, who had so ably acted as their Secretary. Mr. W. Hoey seconded the vote of thanks, which was cordially agreed to. The Chairman replied, and bore out the remarks as to the way Mr. Ballinger had done his work. Mr. Ballinger thanked the members very sincerely for the vote of thanks. If he had any wish for his successor it would be that he might have twice as much work as he (Mr. Ballinger) had had to perform. Mr. Henshall remarked that, as they all knew, he was a bashful man—(laughter)—and before they had lunch he would give them, on behalf of the Paxton Society, a hearty welcome to Barnsley. (Applause.)

After the luncheon the company departed to enjoy their pleasant visit to Wentworth Castle. With characteristic kindness Mr. T. F. C. V. Wentworth had placed his noble mansion and grounds at the disposal of the Association. The company drove there in waggonettes supplied by Mr. Collier. The members were conducted over the castle by the housekeeper, and especially admired the picture gallery, with its almost unique collections of paintings; and they were escorted through the beautiful gardens and conservatories by Mr. Batley, the head gardener, and his son.

In the evening, after an excellent tea had been partaken of, Mr. W. Hoey presided at the meeting, at which a most interesting paper was read by Mr. Wright of London on "the social, intellectual, and professional position of gardeners." There was a good attendance, including several ladies. In the course of his remarks the lecturer, who was frequently applauded, pointed out that young men should remember that they would not be judged by what they may say or do, nor by the best of their associates, but the worst. He advised them not to make friends in a hurry, but to make sure that they were always better men than them-



selves. Again, with regard to work, the man that was afraid of doing too much was apt to be left behind in the struggle of life. Above all, let them be just in all their actions. The question of the social position of gardeners was one of individuality. He had mixed sufficiently long in communities to know that the mere possession of money was not unvarying evidence of greatness of mind; and also to know that the absence of material riches involving the necessity to labour is perfectly compatible with nobility of character. Speaking of employers, the lecturer remarked that there were cases when the gardener was the gentleman in the truest sense of the term, and the employer was, well—something of the other kind. (Laughter, and hear, hear.) But he went on to say they were abnormal and exceptional, the overpowering majority being considerate and kind. There were peculiar gardeners, too, some of whom were not particularly manageable; and he expressed his belief that when the social position of gardeners was kept at a low level through circumstances beyond their own control there was an infinitely greater number of cases where it might be raised by watchfulness over their own conduct, such as forbearance under small provocations, restraint in the expression of their feelings and views, with the exercise of unvarying courtesy, especially in moments of difficulty when the temptation might be great to assume an attitude not conducive to harmony of feeling nor calculated to establish that confidence and mutual trust that it was so desirable to promote between master and man. Speaking of the intellectual position of gardeners, the lecturer said that a gardener should not only be a working, but a thinking man; and he enforced the importance of chemical and scientific knowledge. He should have some knowledge of hydrostatics, botany, and other kindred subjects. As to the professional position of gardeners, some of the men holding the best posts now were hard-working, plodding men. The most accomplished scientific gardener he ever knew was the best digger he ever met. Some of the best trained gardeners were digging yet, plodding honestly on for a better position, but that was not to be gained by impatience and from working grudgingly because the "place is not good enough." The position of many a gardener had been ruined through that one mistake; and whenever a duty is undertaken it should be performed faithfully and well or relinquished. Mr. Wright concluded by quoting the following lines:—

"Praise not thy work, but let thy work praise thee,  
For deeds, not words, make each man's memory stable;  
If what thou dost is good, this good all men will see—  
Musk by its smell is known—not by its label."

The Chairman then invited discussion, and Mr. Woodcock (Sheffield) thanked Mr. Wright for his paper. He wished it could have been heard by young and old gardeners throughout the Riding. The subject was of great importance to societies such as their own, and there was no doubt that they could be made much more useful if scientific lectures could be given. They might be a means of getting young men to join. No, doubt, as the lecturer said, the position of the gardener depended a good deal on himself. He did not believe that a trades society in which they had to work in a certain groove would be a good thing for them. He believed that was one time the case with regard to Sheffield. Mr. Wright, in reply to a remark of last speaker, dwelt on the importance of getting men to join societies, and having scientific lectures given by men of ability. Mr. Smith (Leeds) and Mr. Cooke (Rotherham) also took part in the discussion, and a vote of thanks to the lecturer was passed amid loud applause, on the motion of Mr. Batley, seconded by Mr. Garnett, and supported by Mr. Kay. The lecturer suitably replied, and the vote of thanks to the Chairman brought the proceedings to a close.—(*Barnsley Independent*.)

## ROMAN HYACINTHS.

THE earliest supply of these bulbs can now be obtained, and the samples we have already seen are exceptionally good, being firm and of large size. Where a lengthened supply of these useful flowers for cutting and decoration in pots is needed, the bulbs should be obtained and potted without delay. Place five bulbs in each 5-inch pot, and the smaller ones, if only needed for cutting, may be placed thickly together in pans or boxes. This necessitates selecting the bulbs upon arrival, a practice we have followed for years. The best and finest are reserved for pot culture, while those of a smaller size have been reserved for grouping and cutting purposes. Some care must be exercised at this period of the year in the preparation of the soil, for at potting it should be on the moist side rather than the reverse, at the same time it must not be wet. We strongly condemn the practice of watering the soil after potting until the bulbs have filled their pots with roots and are removed from the plunging material.

The position in which they are to be plunged should be in a northern aspect, where moderate moisture can be insured in the plunging material without entailing much labour. In a sunny place the moisture from the plunging material is quickly evaporated, and then the soil about the bulbs becomes perfectly dry, with the result that they rest instead of starting to grow and make roots. It is important that they be covered directly they are potted. A greater depth of plunging material is needed over the earlier bulbs than for those a month or six weeks later. It is also a good plan to cover the surface of the plunging material with litter.

There is no difficulty in maintaining a supply of these flowers from the end of October until February, provided they are potted at intervals of a month until the end of October or the middle of the following month. This depends upon the condition of the bulbs and how they keep. If out of the soil too long they begin to grow and then are soon useless. Our latest supplies are always obtained from bulbs planted in the open ground, and directly they show signs of coming through they are covered with handlights. Some to precede these are planted a fortnight earlier and covered in the same manner at the approach of severe weather. Bulbs treated on these principles have been lifted and are in excellent condition, and will be placed thickly together in boxes for yielding an early supply of flowers for cutting.—L.

## SEED SELECTION AND HYBRIDISATION.

### MESSRS. WEBB'S EXPERIMENTS AT KINVER.

FOR several years an extensive series of experiments in the selection and hybridisation of garden and field crops has been conducted by Messrs. Webb & Sons at Kinver in Staffordshire, a few miles from their great seed establishment at Wordsley, near Stourbridge. Here many hundreds of acres are devoted to proving the varieties, and the subsequent working up for sale of a stock of such of them as reach the standard of excellence aimed at by the raisers. In the course of a few years they have been successful in producing and placing before the public a number of sterling novelties in garden and cereal crops, and the work is being pursued with undiminished energy at the present time. It is a favourite amusement with many persons in private establishments to try experiments in crossing vegetables and flowers. In many cases this is done with no definite view, and the knowledge and judgment necessary to insure something approaching a profitable result are entirely lacking. Still, chance sometimes favours the inexperienced in his interesting pursuit, and the casual production of a "good thing" stimulates him and others to further experiments of a like nature. What private persons may amuse themselves by doing in a small way as a hobby, Messrs. Webb & Sons do in a large way with a serious business object. Instead of a few square yards to devote to experiments in plant and seed raising they have something like 1600 acres, and every yard of it is utilised. The greater portion of this land is freehold. It is not so much a seed-growing farm as a huge trial ground. Comparatively few seeds are saved for sale at Kinver. Nearly the whole of the ground is devoted to the selection of stocks for placing in the hands of their growers in various parts of this country and the Continent. Perhaps a faint idea can be gained of the amount of seeds required to meet Messrs. Webb's trade when it is stated that they estimate the amount of land in various parts thus devoted to raising seeds from stocks supplied by them to be as much as 17,000 acres. The seeds are grown under contract, the firm stipulating for the right to inspect the crops with a view to "rogueing" them—that is, removing any chance plants that are not of the true stock. This right they exercise with careful regularity, thus keeping their stocks pure.

Two thousand three hundred trials of vegetables, flowers, and cereals are now being conducted at Kinver. Hybridisation is being constantly practised, and stocks are being worked up of "crosses," which, after careful trial, have been considered worthy of being brought before the public. The ordeal these varieties undergo is no light one, and it may be interesting to refer to the process by which new and improved varieties are raised on a large scale. Crossing is of course effected in the first case by artificial impregnation, judgment being exercised in the selection of suitable parents. The produce is carefully examined, and as it frequently occurs that the plants resulting from a cross differ not only from the parents but from themselves, several distinct varieties are secured, the worthless being thrown away and the promising ones preserved for future trial. The varieties preserved are carefully tested and compared a second year, further weeding out being practised, and it is only after full trial and comparison with standard sorts that a sufficient quantity of seed is raised to be placed in the hands of a skilled grower commanding a suitable soil for being worked up in quantity for sale. The best are selected from the best. That is the system in a few words; thus nothing is submitted to the public until repeated experiments have proved its distinctive merits. This care has its reward. Messrs. Webb find that their novelties invariably meet with a ready sale, so well satisfied are their patrons of the reliability of their judgment in recommending new varieties of vegetables or flowers. A few instances may be given haphazard in the Wordsley Wonder and Chancellor Peas, Emperor Cabbage, Kinver Longpod Beans, Improved Banbury Onions, Surprise Potato, &c., all of which are now in general demand as varieties of admitted excellence.

It may be well to give some statistics of Messrs. Webb's operations. Of Peas 85 acres are grown, 150 sorts being on trial, with various crosses, several of which bid fair to be of considerable value. It is the object of Messrs. Webb's able manager to get a race of handsome prolific and well flavoured Peas with square or blunt ends, and to gradually discard the varieties with pointed pods, in which, as he remarks, a Pea is wasted. Besides the two fine varieties already named, four others—Kinver Gem, very early. Electric Light, Stourbridge Marrow, a fine main crop variety, and Triumph—have recently been introduced, and all have been favourably received. Potatoes are also a great feature, Messrs. Webb doing a very large Potato trade. Seventy acres are devoted to them at Kinver, from whence several fine sorts have already

been sent. Benefactor, Discovery, and Kinver Hill were sent out in 1886, and have "caught on" unmistakably, and favourable reports are being received of Wordsley Pride, Renown, and Red King, which were sent out this season. Stocks of several excellent seedlings are expected to be large enough to justify their being offered next spring; these will be heard of by-and-by.

Other vegetables of somewhat smaller importance are also being experimented on extensively. Of Cabbages, besides Emperor, a variety named Flockmaster, recommended for farm cultivation, has quickly become popular. In Broccolis there are new autumn and winter Whites, besides the late May Queen; in Savoy, Little Wonder and Kinver Globe; in Carrots, Defiance, Intermediate, and Market Favourite; in Celery, Mammoth Red and Pearl White; in Cucumbers, Perpetual Bearer; in Lettuces, Criterion (Cabbage) and Monstrous White (Cos); in Melons, Royal Warrant and Pride of Stourbridge; in Tomatoes, Jubilee and Sensation. These are all of recent introduction, but all sell largely, and of most there are fresh varieties coming on.

The extent of Messrs. Webb's agricultural trade demands that special attention should be given to cereals. These are a remarkable feature of the gigantic trial grounds at Kinver. One hundred and ninety-one acres are devoted to Wheat trials and crosses. The results already secured have been most encouraging. The new varieties—Kinver Giant, Hybrid King, and Challenge White have been most favourably reported on. The former is a grand white variety that is in great demand, and Challenge White has won many important prizes. Several hybrids are under trial. The same remark applies to Barley, of which 201 acres are grown. Kinver Chevalier, a most prolific sort, Golden Grain, and Webb's Beardless are the pick of those already placed before the public. Of Oats there are 160 acres; Challenge White Canadian, White Tartarian, and Black Tartarian are in the greatest demand, and all are excellent kinds. The Imperial Swede is another sterling farm novelty of Messrs. Webb's introduction. This variety has secured the first and second prizes at the Birmingham Show for fifteen consecutive years, and has an enormous sale. It may be interesting to state that at the farm competition in connection with a recent show at Newcastle for the Royal Agricultural Society's prizes, Messrs. Webb informed us that all the prizes to the value of £475 were won by their customers. In connection with the farm trials it may be mentioned that a series of experiments of artificial manures, in which the firm deals largely, having a manufactory at Widnes, are being made. Some thirty or forty experiments are being tried with Swedes, and others with Potatoes.

In the case of both vegetables and cereals it should be remembered that, large as is the extent of ground devoted to the more important crops, it comprises trials only, the seeds for sale being all grown elsewhere. But it may be stated that as a further precaution samples are taken of all seeds remitted to the firm by its growers, these being sown at Kinver with a view to making certain that the stock in bulk is as true to name as the trial stock was when forwarded from Kinver.

As with vegetables and corn so with flowers. Stocks are carefully selected and raised at Kinver, then placed in the hands of a skilful grower to be raised in sufficient quantity for the year's supply. Asters and Stocks are tried on a larger scale. Of the former a selection named Webb's Miniature was noticeable, the plants being 6 to 9 inches high, bushy, and bearing large flowers. Webb's Imperial Stock is a large flowering pyramidal strain, double, and in great variety of colour. Other popular annuals lent brightness. There was a fine bed of double Zinnias, others of the beautiful scarlet Flax, *Linum grandiflorum rubrum*, *Calliopsis Drummondii*, Webb's dwarf Mignonette, very sweet and green; the pretty *Chrysanthemum inodorum plenissimum*, which grows a foot high, produces abundance of small double white flowers, and is worthy of more extended culture; *Nasturtium* in various colours, very gay; purple and white Candytufts, white Rockets, Clarkias, &c. These are too well known to need lengthened comment; a few specialities may be mentioned, however. Golden Cloud *Chrysanthemum* is a selection presumably of *C. earinatum*. The flowers are large and bright yellow. A bed of this annual was wonderfully even and gay. The new Sterling Poppy is very showy too, being distinguished by floriferousness and brilliant colours. Webb's new hybrid *Mimulus* is an excellent strain of the popular Monkey Flower, the colours remarkably rich. Webb's Invincible Sweet William is also a very fine strain, the colours of the blooms being unusually decided and diversified. Pride of Kinver *Verbena* embraces a great variety of brilliant hues, and is noteworthy also for the large size of the flowers.

Amongst what may be styled odd crops at Kinver are some Tobacco trials, which have been conducted on a somewhat extensive scale. Messrs. Webb recommend the following twelve varieties as amongst the best for cultivation in this country:—Big Frederick, Connecticut, Cuba, Florida, Havana, Island Broad Leaf, Kentucky, Maryland, Pennsylvania, Virginia, White Burleigh, and Yellow Prior. Maize and Sorghum are also being tried, and Messrs. Webb are experimenting with them on their own cattle, with results that they will perhaps refer to by-and-by.

A few words may be devoted to the seed warehouses, which consist of several fine blocks. They are freehold, and have been erected within the space of a few years by Messrs. Webb to meet the requirements of a rapidly increasing trade in farm and garden seeds. The largest block comprises five floors, 180 feet by 60 feet, and there are others nearly as large. At present they are comparatively empty; a largely increased demand this year having drained the stocks below the estimated point, and the new supplies are not, of course, coming in yet. Messrs. Webb's trade in Swedes, Mangolds, Clovers, Grasses—in fact all agricultural

seeds, is enormous. Large spaces, each marked with a separate label, are reserved for each kind, but the removal of hundreds of sacks in many cases has left them very bare. There is eloquent evidence indeed that the dull season of the seed trade is upon the great firm. Huge lifts, steam-worked, are motionless. The wonderful seed-cleaning machinery, that it has been the object of Messrs. Webb to render as perfect as possible, so as to insure the absolute purity of all the seeds they sell, is silent too. There the machines are, however, fifteen or twenty of them, ready, when the time arrives, for winnowing, sifting, and blowing.

But if the seed-cleaning and the seed-despatching departments are quiet now activity prevails in others. The early consignments of bulbs are expected almost daily; already there is a foretaste of the invasion in the form of a few hundred cases of White Roman Hyacinths. Large quantities of these are sold for forcing, and the Paper White Narcissus follow them closely. Spaces are now being cleared for the reception of the Hyacinths, Tulips, Narcissus, Crocuses and other bulbs that will shortly come in hundreds of thousands. Some preparations are also being made for the coming seed season, as yet a long way off. Piles of bags and pockets are being labelled for the reception of the seeds, and to be filled as the latter arrive. For the present this is all that can be done. When Christmas is reached the rush of work will commence—a rush that can be imagined only by those who have seen the resources of an extensive staff taxed to the very utmost to keep it in check.

## ROSES IN POTS.

A GOOD supply of Rose blooms from the time those in beds and borders outside fail until they can be had again another year is of even greater importance in many gardening establishments than the outside supply. Any neglect in the management of the plants at this season will certainly end in disappointment. Any of the Noisette varieties, such as Lamarque, William Allen Richardson, or Tea Roses of the same habit of growth, of which Gloire de Dijon may be taken as the type, that flowered early and have been grown under glass, will be sufficiently ripened for turning outside. These should not need potting if it was done in early spring after flowering, which is decidedly the best time. About this time of the year these are most liable to burst into fresh growth from many of the main buds. This must be prevented, or the flowers will probably be produced a few weeks hence instead of next February or March. If the wood produced after this date could be well ripened there would be no need for their removal, but in the northern counties this is impossible, even if the autumn proves bright and fine. The safest course then is to tie the plants with their branches upright to a wall or fence outside. The condition of the plants must determine whether they occupy a southern aspect or the reverse. If well ripened a northern position will be most suitable for the next month or six weeks, especially if bright hot sunshine continues. If the plants are not well ripened the brightest place should be given them, so as to harden and thoroughly mature the wood. The pots may be plunged to save labour in watering, and the surface well mulched with manure. These plants may occupy these places until the approach of frost, when they may be top-dressed with rich material and trained to fine stakes placed round the sides of the pot, or trained to short stakes after the fashion of an inverted saucer. This trouble need not be taken if the blooms only are needed for cutting. It is a simple and easy method of training when the shoots are twisted round stakes, and this induces every bud to break and produce a flower.

Attention should now be directed to the old China Rose, if plants were potted last autumn for flowering under glass from the middle of October. These old favourites deserve more extended attention for autumn flowering in pots, for their sweet pink and crimson buds are invaluable at that season. They flower freely, and the blooms associate admirably with the delicate buds of light Tea varieties. Plants that are in 7 or 8-inch pots may be placed at once into others 2 or 3 inches larger. This should be done without disturbing the ball further than the removal of loose soil from the top and the old drainage from the base. If the pots are plunged and the surface of the soil and rim of the pot covered, they will root freely in the new soil—in fact, the pots will be full of active roots by the third week in September, when they may be housed. Little, if any, water will be needed at their roots if the plants are syringed liberally twice daily, and the plunging material kept moist. If dry weather continue, however, examine the soil, as if allowed to become dust dry the plants will soon become a prey to mildew, and prove useless for yielding a bountiful supply of buds. Pinch off the flower buds as they appear until the plants are housed, when they will quickly break into fresh growth and flower.

Tea varieties intended to flower at the same time, and maintain a supply up to Christmas, should also be repotted. These plants must now be practically at rest. Some may have young growth upon them, but this need not prevent the operation. Soft growths may be well pinched back or cut away completely. For this purpose plants

that are well established in pots with plenty of old and well-ripened wood about them are decidedly the best. If the plants are in pots as large as may be desired they can be turned out, and the balls reduced about one-third or more, according to the condition of the soil and the roots of the plants. In reducing the balls every care should be taken to preserve all the fibre possible, and then the plants will take to the new soil and become established. When the balls are reduced one-third the same size pots may be used. If necessary to increase materially the size of the plants more root room may be given them, and the ball only slightly reduced, or not at all. This depends upon whether the soil is sweet or the reverse, and the quantity of healthy roots the plants possess. Nothing is gained by using large pots after the specimens have been well developed. When the balls are reduced press the new soil moderately firm—in fact, firmer than is beneficial when potting young plants. The object must be to place in the pots as much food as possible, for it must be remembered that the plants will have to grow in the same pots for twelve months. If room can be found in a deep pit or house that can be kept close, and the plants shaded from the sun for ten days or a fortnight, the roots will be active, and the plants may be hardened and plunged outside the same as advised for China Roses. If this provision cannot be made for them they may be plunged out directly they are potted. The foliage should be liberally syringed in either case. Weak growths may be thinned out and the plants re-staked and tied, so that at housing time only the newly made growth will need tying into position. After root-action has commenced growth will soon start away strongly, and the flower buds must be removed until the plants are housed or sheltered from early frosts.

Young plants that were raised from cuttings last July and August, or by grafting early this year, may be placed into 10-inch pots. The object should be to induce them to grow freely and become thoroughly established in the pots before the approach of winter. This will be the case if the plants are grown under glass with plenty of light and air. Strong growths that issue from the base should be pinched to induce them to branch and prevent their robbing the remaining portion of the plant. These plants would flower freely during November, but will be better if the flowers are removed and the plants allowed to rest naturally ready for starting into growth early in the new year. Plants of *Maréchal Niel*, *Gloire de Dijon*, and such varieties raised from cuttings in February must be trained close under the roof, and retained in that position until the approach of winter, by which time they will have developed strong growth, and ripened it sufficiently well to flower freely during the spring months. Any Tea varieties that were rooted during the spring, such as *Safrano*, *Niphotos*, *Madame Falcot*, *Isabella Sprunt*, and others, now in 5 and 6-inch pots, will abundantly repay for planting out under glass. Houses that have been cleared of Melons, Cucumbers, or Tomatoes, or will be shortly, can be devoted to them; they will do remarkably well without entailing much care or labour. If we suppose the house has been used for the first-named, all that is needed is to dig the soil and incorporate with it a liberal quantity of leaf mould, and a little sand if very heavy. The Roses may be planted closely together. All the labour needed after planting is the removal of flower buds, syringing twice daily, and give a soaking of water when they require it. These plants will flower freely until Christmas. They can then be thrown out or lifted, shaking all the soil away from their roots, and be repotted in 6-inch pots and wintered in a cold frame. In February they can be planted outside, or pruned close back and allowed to come forward in cold frames, when it will be found that they will produce some useful flowers just before Roses are plentiful outside. If retained in pots they should be pruned close back, and strong shoots will spring from beneath the soil. They can be planted out after flowering, or repotted for flowering again the following spring. If this is done they will be ready for 9-inch pots at this period of the year, and if kept under glass will make excellent plants.

Hybrid Perpetuals and Moss varieties that were lifted from the open ground and placed in 7-inch pots in October or November last may be placed into 10-inch. The roots of these should not be disturbed more than is necessary to remove the drainage. These should have strong sturdy growth upon them if they were brought forward in cold frames to precede outside plants. Do not bend down or tie out any of the shoots, or they will break into new growth from near the base and fail to ripen properly. Allow the plants to grow from the uppermost portion of the shoots, so that root-action in the new soil will be encouraged. Any strong shoots that start from the base must be pinched to prevent their robbing the remaining portion of the plant. These plants will make capital half specimens if brought steadily into flower during the month of April. With this object in view the shoots may be pruned moderately long and trained towards the rim of the pots. When this is done the plants must be brought forward slowly, or they will break at the ends of the shoots instead of all along to the

base. Moss varieties may be potted, but require to be pruned close back; nothing is gained by long pruning. The four best for pot culture are without doubt *White Bath*, the old common Moss, the *Crested*, and *Blanche Moreau*. The last is by far the most vigorous grower, but we prefer the first, for the buds are more beautifully covered with moss; in fact, it is an excellent companion to the old but popular common variety.

Plants that flowered at various times during the spring months under glass should be repotted. The majority of these will be in 10-inch pots, which is plenty large enough unless the plants are required for exhibition purposes. The old roots should be reduced about one-third the same as advised for Tea varieties, and the plants should be plunged and treated the same after potting, with this exception, that they need not be placed under glass until after the approach of frost.

Any plants, whether Tea, Moss, Bourbon, or Hybrid Perpetual, that are found to have the soil sour when potting, should not only have the ball reduced one-third, but the whole of the soil must be shaken from the roots. If the plants are passed over and repotted in the condition indicated they are certain to be unsatisfactory next season. Shake away all the old soil and repot the plants in fresh, placing them in smaller pots. They will become at least partially established before winter, and will make strong vigorous growth the following season, provided they are given a season of rest by being allowed to come on slowly in a cold frame. This is the best and surest method of recruiting any plants that have declined in vigour through forcing them early in the season.—R. M. B.



MESSRS. BARR & SON, 12, King Street, Covent Garden, send us a stem of *LILIUM JAPONICUM COLCHESTERI*, bearing a head of three flowers, much like the ordinary *L. japonicum* in the shape and the brownish colouring on the outer surface of the corollas.

— INSECTS AT FLOWER SHOWS.—At the Astwood Bank Flower Show held last week, Mr. J. Hiam exhibited Barley straw infested with the Hessian fly, also specimens of various other plants with the insects attacking them. We think exhibits of this nature at agricultural and horticultural shows could not be otherwise than instructive to many visitors, and the course adopted by Mr. Hiam appears to be very commendable.

— "J. B. H." writes on HOME-MADE CIGARS:—"I remember some time ago someone sent you a cigar made from Tobacco dried in a close Melon house, and you stated you would lay it past for some time to season. You might inform me if that would be the best place to dry it also what is the best way to manufacture a few home-grown plants, and oblige." Our correspondent who sent us the cigar will perhaps answer this question if it meets his eye. The cigar was rather too closely rolled and "hot." In cigar-making it must not be forgotten there are revenue authorities and penalties against any transgression of the law.

— THE SHEFFIELD AND WEST RIDING CHRYSANTHEMUM SOCIETY.—At the suggestion of one of the Vice-Presidents of this Society, C. E. Jeffcock, Esq., a midseason dinner was held at the "Clarence Hotel," High Street, Sheffield, on the 2nd inst., which was attended by several members, Mr. Jeffcock ably presiding. The object was to draw attention to the work of the Society and stimulate public interest in the coming campaign. It will be remembered that the Society offers a 15 guinea cup and £10 as a first prize for blooms, to be won absolutely at the November Show, with other valuable prizes in the same class. Another Society in Sheffield offers £20 as a first prize. It would seem that if the two Societies were to combine Sheffield might have the honour of providing the long-looked-for 50-guinea cup for Chrysanthemums, the same as is now offered for Roses at the National Rose Society's Shows.

— "B." sends the three following notes—"We have grown *LOBELIA WAVE OF BLUE* for the last three seasons, and consider it by far the best sort grown. It is of the same type as *Paxtoniana* and *Lady McDonald*, but much more floriferous, and is in colour a true blue, and not of a purple hue, as so many *Lobelias* are. It has the further



desirable property of continuing in flower until stopped by cold, and does not, like the *Primula* section, give up on account of a hot August. Princess of Wales is the prettiest white variety we have tried. We have this very good this season."

— "THOSE who care for a good plant for lines in flower beds will find in *TROPÆOLUM MRS. ELLICE* a decided acquisition. Of the same type as the now well known *Tropæolum Vesuvius*, this sort has a leafage of a prettier shade of green, being very much lighter in tint. The colour of the flowers is a soft orange scarlet, and the flowers are most freely produced. It is in all respects a most desirable variety."

— "HOW is it no one has been found to say a good word for the *VARIEGATED FICUS ELASTICA*? We have a pair of plants in 5½-inch pots about 4 feet high, and I do not think it would be easy to surpass them in beauty. The variegation in most of the leaves is almost a pure white, much better than we have seen it. The plants are grown in a stove and shaded from sun, but with plenty of light. During winter they stood in a cool Orchid house. I do not think it would be safe to keep them so cool as the green form. Though difficult to reproduce, I believe by rooting the tops of strong plants shoots are formed at the axil of the leaves, which when big enough also strike well."

— THE BRIGHTON AND SUSSEX FLORICULTURAL ASSOCIATION will hold their thirty-fifth Exhibition in the rooms of the Royal Pavilion on Wednesday and Thursday, September 14th and 15th. The schedule enumerates eighty-two classes, in which first, second, and third prizes are offered, varying from £8 to 2s. 6d. Plants are well provided for both in open and local classes, cut flowers and fruit also have several classes devoted to them. The London, Brighton, and South Coast Railway Company have made their usual liberal arrangements to convey exhibits to and from Brighton free of charge. The Secretary is Mr. Edward Carpenter, 96, St. James Street, Brighton.

— THE fourth annual Exhibition of the RAMSBOTTOM FLORAL AND HORTICULTURAL SOCIETY will be held on Saturday, November 19th, this year, in the St. Paul's School Rooms, Ramsbottom. Most of the classes are devoted to Chrysanthemums, but there are also some for stove and greenhouse flowers, Orchids, table plants, Primulas, and Ferns. Mr. B. Markland, 57, Bolton Street, Ramsbottom, is the Secretary.

— MR. W. YOUNG, Baston Gardens, Kintley, Berks, writes:—"Being invited by Mr. A. Hankney, Inkpen, Berks, to inspect his *RASPBERRY LORD BEACONSFIELD*, I must say it is wonderful, considering the dry weather we have had, how well they look; the berries are large and the crop is very heavy. It was late in the afternoon when I arrived, the pickers had been over them, and so the enclosed are small berries." Owing to the fruit being packed in such a fragile box and in cotton wool it arrived in a very bad condition, and it is impossible to express any opinion on its merits.

— MR. A. PETTIGREW, writing from Cardiff Castle Gardens, observes:—"THE DROUGHT is beginning to get rather serious in this district. I understand that the water supply for Cardiff at present in the reservoirs will not last much more than fifteen days if we have no rain, and we are now put on short allowance. The annual rainfall in the gardens here averages about 41½ inches, and up to the present time (from the beginning of January) the fall has been only 10.63 inches, distributed as follows:—January, 2.98; February, 1.35; March, 2.58; April, 1.45; May, 1.9; June, 6.1; July, 1.47. Fruit and other crops are suffering for the want of rain, and if it does not come soon many of them will be complete failures."

— GARDENING APPOINTMENTS.—Mr. Andrew Smith, who has been foreman with Mr. Pettigrew at Cardiff Castle for the last seven years, has been appointed gardener to Col. Hill, C.B., M.P., Rookwood, Llandaff. Mr. T. Whillan, the well-known Orchid grower of Balham, has been appointed gardener to the Duke of Marlborough at Blenheim.

— WE are requested by Mr. F. Hopkins to state that the prizes for white Grapes and Cucumbers at Esher were won by Mr. A. S. Hookings.

— AT the recent meeting of the members of the WAKEFIELD PAXTON SOCIETY Mr. Henry Oxley presided, and Mr. Arthur Goldthorpe was in the vice-chair. Mr. J. G. Brown, gardener to Mr. J. B. Charlesworth, J.P., of Hatfield Hall, read a thoroughly practical paper on "The Pea," of which there was a large number of dishes of speci-

mens of many varieties on the table. Mr. Brown, who is a Kentish man, gave his fellow Paxtonians the result of long and extensive experience as a grower of the best kinds of Peas for culinary purposes, named some of the best varieties to grow to keep up a succession from early to late in the season, and clearly and fully explained the best mode of planting, sticking, &c. In the course of his remarks he spoke highly of the variety known as "Pontefract Castle," which, he said, is very similar to the well-known *Ne Plus Ultra*. He also referred to "Arthur Lupton" as a good useful variety. After a few questions had been put to Mr. Brown and replied to by him, a hearty vote of thanks was accorded to him for his essay, and also to the exhibitors of specimens, particular mention being made of a grand lot of varieties sent by Mr. Hemming, of Leeds. The motion was proposed by Mr. A. Goldthorpe, seconded by Mr. T. Garnett. Mr. B. Whiteley proposed that Mr. Alan Willis (Messrs. Leatham, Tew, and Co.) should be elected Treasurer in the place of the late Mr. Turner, and this was seconded by Mr. T. Garnett and carried, and the vacancy created on the Committee by Mr. Willis's appointment as Treasurer was filled by the election of Mr. B. F. Glover of Alverthorpe.

— AN important botanical periodical is about to be issued by the Delegates of the Clarendon Press, says *Nature*. It will be entitled *Annals of Botany*, and will be edited by Prof. Bayley Balfour of the University of Oxford; by Dr. Vines, Reader in Botany in the University of Cambridge; and by Prof. W. G. Farlow of Harvard University, Massachusetts, U.S.A. The papers, adequately illustrated, will be on subjects pertaining to all branches of botanical science, including morphology, histology, physiology, palæo-botany, pathology, geographical distribution, economic botany, and systematic botany and classification. There will also be articles on the history of botany, reviews and criticisms of botanical works, reports of progress in the different departments of the science, short notes, and letters. A record of botanical works in the English language will be a special feature. With regard to the last point, the editors direct attention to the fact that many important contributions to botanical science are not at present brought before the botanical world with that promptitude which their merit deserves, and many are frequently entirely overlooked, owing to the fact that the periodical in which they appear is not readily accessible to botanists generally. An attempt will be made in the *Annals of Botany* to remedy this state of affairs; and it is hoped that it may be possible to make the record fairly complete, embracing works published not only in Great Britain and Ireland, but also in India and the colonies, and in America. To enable them to carry out this intention the editors appeal to the secretaries of local scientific institutions, societies, and clubs in all parts of the world to send them early information of the publication of papers relating to botany in any of its branches.

#### SCOTTISH ARBORICULTURAL SOCIETY. ANNUAL EXCURSION.

BY gracious permission of Her Majesty, the annual excursion of the Scottish Arboricultural Society took place this year to the woods and forests of Balmoral. Such a privilege was very heartily appreciated by the members, who turned out in larger numbers than they have for some years past. The company, indeed, was large and representative, over seventy gentlemen being present from different parts of England and Scotland. Not a few of the English members were attracted at this time to the North by the prospect of seeing Her Majesty's Highland home. The larger part of the company travelled from Edinburgh on Wednesday afternoon, and spent the night at Aberdeen. The whole company left Aberdeen on Thursday, July 28th, at 7.45, arriving at Ballater about half-past ten o'clock. Among others present were Dr. Cleghorn of Stravithy; R. V. Kirk of Penyvern, Wales; Professor Boulger, London; Messrs. James Watt, Carlisle; Dunn, Dalkeith; Alexander, Edinburgh; Milne, Edinburgh; M'Corquodale, Scone; John M'Laren, Hopetoun; W. Rayson, Chelsea; J. B. Kidd, Dornoch; D. Scott, Darnaway; R. D. Ker, W.S.; Crawford, San Francisco; W. Erskine, Edinburgh; T. Waugh, nurseryman, New Zealand; James Barton, forester, Hatfield; John Davidson, Haydon Bridge, Secretary of the English Arboricultural Society; D. Dewar, Beaufort Castle; James Kay, Bute; R. Lindsay, curator, Royal Botanic Gardens, Edinburgh; James Rutherford, Yorkshire; W. Christie, Fochabers; D. A. M'Quorquodale, Carnoustie; R. Baxter, Dalkeith; J. Mitchell, Aldie Castle; D. P. Scott, Monifieth; D. R. Falconer, Lasswade; R. G. Swan, Duns; George Dodds, Wentworth; and C. E. Ballater. The party were met by Dr. Profert, Her Majesty's Commissioner, who exerted himself in every way to add to the pleasure of the day. Mr. Michie, forester, Balmoral, who made the social arrangements for the excursion, was also present, and acted as guide. Taking the way up Glen Muick in half a dozen carriages, the party had a look at the Old Knock Castle, and then drove through the woods of Birkhall, the property which was acquired two

years ago by the Queen from the Prince of Wales. A good deal of the wood here is from eighty to a hundred years old, and though not of great size, in consequence, apparently, of having been neglected in its youth, the trees everywhere presented a very healthy aspect. They consisted of a mixture of Scotch Fir, Larch, and Birch. The great feature of the woods seen during the day was undoubtedly the natural Birch, which grows to a considerable size, and has in this quarter a most graceful, drooping habit. The largest Oak met with was 5 feet 7 inches in girth at 5 feet up—a measurement not at all contemptible for so high a region. Further up the Muick the only other trees measured were a Silver Fir, which was 8 feet 8 inches in girth, and 75 feet high; and a Spruce 7 feet 7 inches in circumference, and 90 feet high—Kay's dendrometer being used to determine the altitude. Some very good Larch was also met with, two measured being 113 and 110 feet high respectively, while the girth was 8 feet 1 inch and 8 feet 6 inches. The drive was continued up Glen Muick to Altnaguissach Loch.

The party afterwards drove by the road over the hill to Balmoral, which was reached at three o'clock. Here the company, by instructions from Her Majesty, were entertained to luncheon. Dr. Profeit presided, and proposed the health of Her Majesty, which was heartily responded to. Dr. Cleghorn said it would be his duty to transmit, on behalf of the Society, at the proper time, a minute to Her Majesty, expressing their cordial and grateful thanks for the kind reception they had received, and for the gracious permission which had been accorded them to visit Balmoral. Before leaving the Castle the company were asked to view the service room, which is lined throughout with Scottish Fir from Ballochbuie, beautifully polished and varnished, and was greatly admired. The rest of the afternoon was spent in viewing the home woods and other objects of interest in the grounds. A fine avenue of the Stone Pine between the castle and the stables attracted much notice, the trees being large and well grown, and in vigorous health. Some Douglas Fir and other examples of the newer coniferous trees were also met with, though not of any great size. The wood in the home policies for the most part consists of young timber, which it seemed to be the general opinion is being well managed. In the nursery which the forester has recently established there were some capital seedlings—Scotch Fir, raised from cones from Ballochbuie forest, which contrasted very favourably with others of the same variety imported from another part of the country. The party had also pointed out to them the Stone Pine which Her Majesty planted on the 13th June last—the Jubilee tree—before leaving Balmoral for London.

The visitors were very much interested in the preparations which are being made by the *employes* on the Royal estate to erect a statue of Her Majesty in commemoration of the Jubilee. The figure will be in bronze by Boehm, R.A., and the pedestal will be of rustic work, corresponding to that of the statue in the grounds to Prince Albert, which it will face. In the district generally the grass crops and trees were found to have suffered from the great drought, and it was stated that the river had not been so low since 1826. The rainfall at Balmoral for the year up to date has been 10.26 inches, as compared with 18.03 inches last year. In consequence of the impossibility of putting up so large a party at Braemar half the company returned to Ballater, and found lodgings at the "Invercauld Arms." The other half went on to Braemar, and were divided between the two hotels—the "Fife Arms" and the "Invercauld Arms." At the dinner in the "Fife Arms" Dr. Cleghorn presided. The Chairman, in proposing the health of the Queen, said they had all that day derived great enjoyment and profit from seeing the demesne of Her Majesty. (Applause.) The health of the Royal Family having been pledged, the Chairman gave the toast of Her Majesty's Commissioner, and said they had been greatly indebted to him for his kindness and courtesy. He had given up the whole day to their service; and they hoped to receive further kindness from him on the following day. They all wished him and his family much health and happiness. (Applause.) Dr. Profeit shortly replied. Mr. James Watt (who officiated as croupier) proposed the Scottish Arboricultural Society. During the last fifty years he said great advances had been made in many of the arts and sciences, and in none of the sciences had greater progress been made than in arboriculture. During the last quarter of a century the world had been ransacked for new varieties of trees; and from California, Japan, and many other countries there had been imported into this country specimens which would yet form the greater part of their forest timber. The Scottish Arboricultural Society, founded in 1854, had been very successful, but never more than at present did they require to stand firmly together, for great influence was being used to get the School of Forestry established—not in Scotland, but in the south of England. Now, Edinburgh, with its great University, its botanical gardens, and other advantages, was the place where they hoped the School of Forestry would be established, and he trusted that a strong effort would be put forth, in conjunction with the Highland Society, to get this great purpose effected. (Applause.) The names of Messrs. Rutherford, McCorquodale, and Maclaren, three of the original members of the Society, were mentioned in connection with the toast. Mr. McCorquodale gave "Kindred Societies," which was replied to by Mr. Davidson, of the English Society. "The landed interest" was submitted by Mr. R. G. Swan, Duns, and was replied to by Mr. Kirke. Among the other toasts was "The health of Mr. Michie," whose services were warmly acknowledged. To-day the Society visit the Ballochbuie forest.—(*The Scotsman.*)

#### A MARKET PLANT NURSERY.

PERHAPS at no place can what may be called the "commercial side" of horticulture be seen to such advantage as at an

establishment devoted to the production on an extensive scale of plants and flowers for Covent Garden Market, such as can be seen in Mr. H. B. May's nursery at Upper Edmonton, that land of market gardens. If we were asked to state briefly the "specialities" grown at this nursery the answer would be Ferns and Carnations. Not that other plants are not well "done," but the plants mentioned are most notable by their superiority and numbers.

Ferns are grown in thousands, house after house being filled with them, and the effect produced by such an assemblage of beautiful foliage plants is better imagined than described, and the interest of the inspection is heightened by the fact that the visitor views them in different stages of growth, from the first evidences of germination—the tiny "prothallus" to the healthy and shapely specimens in 48-sized pots. Just a little "statistical" note here in reference to pots. One order for the last-mentioned was for a thousand "casts" of 48's, representing 48,000 pots! And this kind of thing is constantly going on! I may briefly enumerate some of the more prominent of the market Ferns, beginning with the ever-popular *Adiantum euneatum*, so useful for cutting purposes and grown by the million; *Pteris cretica*, *P. tremula*, *P. serrulata*, *P. serrulata cristata compacta*. The variety grown here under the last-mentioned name is one of the best of the crested *Pterises*, of which there are now so many forms. Mr. May obtained a first-class certificate for this variety at South Kensington some time ago, and as seen here it well merited the award. Another useful sort, and which also originated at this establishment, receiving likewise certificate honours, is *Pteris cretica Mayi*—a crested form of *albo-lineata*, but of a more dwarf and compact habit than the normal form—a great acquisition.

Besides those grown in large quantities for general market work, many of the choicer sorts are cultivated, amongst which are fine *Davallias*, particularly noticeable being *D. Mariesi*, *D. Tyermanni*, *D. elegans* (rightly named), *D. Griffithiana*, *D. decora*, *D. fijiensis*, and the extremely pretty *D. Mooreana*, a choice decorative variety, remarkable for its pale green fronds, associating charmingly with the darker foliage of its neighbours. *Pteris tricolor*—old, but very beautiful, *P. aspericaulis*, *P. argyrea*, *Lastrea aristata variegata*—all remarkable for their coloured foliage. *Gymnogramma Alstoni*, a very pretty golden form, was striking on account of its pinnules being curved inwards, showing off the golden under surface, a great advantage. Amongst *Adiantums* may be mentioned the ever-popular and beautiful *Adiantum farleyense*, grown here in prime condition, *A. scutum*, *A. Victoriae*, *A. rhodophyllum*, *A. macrophyllum*, young fronds beautifully tinted with crimson giving it a very distinctive appearance. In speaking of "coloured" Ferns I was reminded of an admirable article recently written upon this subject in the *Journal*, and in the inspection at Edmonton, where all that was then said upon the matter was well and practically borne out, it was suggested that some of the compilers of schedules at horticultural shows might offer prizes next season for a group of tinted and coloured Ferns. We believe that with proper taste in arrangement a very pleasing effect would be produced, and a new use discovered for this interesting family of plants.

Amongst other numerous Ferns well grown and useful for basket culture may be noted *Nephrolepis Duffii*, *N. pectinata*, *N. acuta*, sometimes known as *N. ensifolia*, very effective for large baskets, of which we saw a number filled with fine examples, admirably illustrating their adaptability for this style of decoration; *N. exaltata*, *N. tuberosa*, and last, though by no means least, *N. davallioides furcans*. *Doryopteris palmata* and *Phlebodium aureum* may be justly noted as good and popular Ferns; *Adiantum cuneatum Pacotti* and *A. cuneatum grandiceps*, a very pretty "tasselled" form of the Maidenhair, are acquisitions.

Amongst miscellaneous foliage plants I especially noted a fine collection of *Crotons*, well coloured young plants, all the good and popular sorts being grown; a very effective display, as seen *en masse*, the effect being enhanced by many of the brighter coloured vars. being arranged down the centre of a house, suspended from the roof. *Picus elastica*, a true market plant, was seen in great numbers. *Cyperus alternifolius*, highly effective and graceful, is produced in quantity. A large number of *Ivies* are grown, the sorts being confined to *Hedera maderiense* variegata; as seen here in long lines the effect produced was very striking; Lee's New Silver, an acquisition; *H. elegantissima*, Mrs. Pollock, and other choice sorts.

By way of conclusion I may refer briefly to the department devoted to flowers, and we may well and justly begin with Carnations. Many thousands are grown, and the stock appears to include all the best varieties. To enumerate a few, Miss Jolliffe, the popular market sort, is more extensively grown than any other variety. Other good sorts that are grown in quantity are Lucifer, fiery scarlet; Andalusia, pale yellow, large "fringed" flowers; Middle Carle, pure white, of dwarf and excellent habit; Pride of Penhurst, the most popular of all the yellow varieties; Indian Chief, deep crimson; Dr. Raymond, also a fine deep crimson; Magnificence, rose pink; Huntsman, bright scarlet; Empress of Germany, white, slightly tipped with pink. What a favourite is the old crimson Clove, with a fragrance so peculiarly its own! Here it is in much request. Of *Azalea Fielder's White*, a valuable market variety, we observed several thousands of fine healthy young plants in 48 and 32-sized pots. Perhaps it is quite within the mark to state that such good young stock of this sterling old variety is not to be met elsewhere in this country. *Bouvardia Humboldtii corymbiflora*, one of the finest kinds in cultivation, was represented by an immense stock, its delicious perfume pervading the house. In *Roses* a quantity of fine

plants of Maréchal Niel are being "grown on" for forcing next year. Niphotos, another popular market sort, so lovely in the bud, is grown likewise in quantity. The General, as that fine old Rose Général Jacqueminot is called amongst the market growers, is much esteemed here. As a final remark to these hasty notes it is but justice to add that the multifarious contents of the establishment reflect great credit on Mr. A. Hemsley, Mr. May's manager.—B. C.

### TWICKENHAM GARDENS.

THE upper reaches of the river Thames attract many disciples of Isaak Walton and admirers of riverside scenery during the summer months. From Kew to Oxford there is a succession of beautiful curves and stretches with verdant grass-clad or tree-capped banks, each mile or so having some distinctive charm. From Richmond to Teddington Lock is an especially interesting portion of such a trip. On the Surrey side is seen the wooded heights of Richmond Park, and on the Middlesex side is a series of picturesque villas, or imposing mansions, with delightfully fresh green lawns sloping to the river, enlivened by beds of and vases of flowers, half hidden in a profusion of luxuriant trees, among which graceful Weeping Willows are suitably conspicuous. In such a torrid season as the present, with lawns in particular and vegetation generally parched and brown, these riverside gardens have an exceptional charm, a refreshing influence that only those can fully realise who are familiar with the depressing effect produced by the drought in most places. Then, too, nearly the whole of the Twickenham side is invested with unusual historical interest, bringing memories to the student of the illustrious people who have made the town their favourite resort. Horticulturally, also, Twickenham is very interesting, for examples of good gardening abound, and as one of the best of these we may select for a few notes the gardens at

#### POULETT LODGE.

The residence of Mrs. Meek is situated on the Middlesex bank of the Thames. The house is of unpretentious design, but now so beautifully covered with the handsome *Magnolia grandiflora* that it has a highly picturesque appearance. The lawn slopes towards the river, being bounded on that side by a terrace walk and stone balustrade, surmounted by vases filled with Pelargoniums and other flowering plants, which have an excellent effect, attracting attention for a long distance up and down the river. Some charming vistas are obtained in the direction of Richmond, one in particular commanding a view of the Star and Garter Hotel at the top of the hill, and towards Teddington is a pretty stretch of river scenery. Trees are noteworthy for their luxuriant health. A fine Weeping Willow droops over the balustrade at one end of the terrace, a sturdy old Mulberry has a central position, and a magnificent Cedar of Lebanon is also seen. Upon the lawn are numerous beds of Zonal Pelargoniums, the favourites being Henry Jacoby; Mrs. Turner, which succeeds admirably and is one of the best pink varieties; Master Christine and Vesuvius; while in the vases near the house single Petunias are freely employed with admirable effect. The Magnolias already mentioned are quite a feature, and their fine condition might make us fancy we were in a warm western county. They are trained close to the wall, but are allowed sufficient freedom of growth to show their large rich shining green leaves and massive flowers to perfection, the fragrance of the latter being very powerful. The trees very rarely suffer in the winter, except one plant at an exposed corner, which has been slightly damaged on one or two occasions.

At the rear of the house are the principal glass houses, devoted both to plant and fruit culture, in which the well known gardener, Mr. W. Bates, has achieved some considerable successes. The chief plant houses are now undergoing repair, but the collection comprises, amongst many good "specimens" of stove and greenhouse plants that have won numerous honours in competition at suburban shows, a number of useful sized plants that are valued for decorative purposes, and all are distinguished by a fresh healthy appearance that is most gratifying. Grapes are an important crop in most establishments, and to them Mr. Bates gives much attention with capital results. A fine lean-to range in four divisions is devoted to Vines, and from these is obtained a long supply of useful fruit. Black Hamburgs are particularly well grown; compact medium size bunches are secured, which this season have been notable for the size of the berries and good finish. Madresfield Court is also a favourite, and no difficulty is experienced with it, as the Vines are allowed to carry plenty of foliage, and no further trouble is needed to prevent the cracking some have found so frequent. The bunches and berries are large and colouring splendidly. Of Muscat of Alexandria there are also some fine samples, substantial well set bunches, and good berries assuming that rich tint peculiar to the well finished Muscats. The Vines are treated liberally, cropped freely, and kept thoroughly clean, while it may be mentioned that for all the houses piping is liberally supplied.

A long Peach house or case contains a number of remarkably healthy trees, bearing a good even crop of fruits, Peaches, Nectarines, and Plums being alike noteworthy in this respect. Of the first named, Mr. Bates very highly commends Alexander as an early variety, as, though a clingstone variety, it is of fine flavour, very prolific, and remarkably early. It was introduced some ten years since by Mr. Rivers, and has gained much favour in many gardens. At Poulett Lodge may be seen an example of Pine-growing that would not disgrace the best growers who make a specialty of that fruit, and it is the more interesting now so few gardeners have an opportunity of showing their

skill in this direction. Abundant as imported Pines are now, there are some who still esteem a home grown well-ripened Pine Apple as the most delicious of fruits, and incomparably superior to those that are so numerous in fruiterers' shops. Mr. Bates grows about eighty-five fruiting plants yearly, and he relies upon the varieties Smooth Cayenne and Queen for the main supply, with a few of Prince Albert for summer and autumn, on account of its peculiarly rich flavour. A pitful of suckers and succession plants just potted are very promising, clean and healthy, while some well developed fruits in another pit are ripening excellently. Several small pits are devoted to Melons and Cucumbers, with frames of Tomatoes, all of which are in large demand.

The chief portion of kitchen garden, comprising about two acres, is on the opposite side of the Cross Deep Road. It is enclosed on three sides by a wall which has been covered with Morello Cherries, Plums, and Pears, the latter as cordons, six trees of each variety, a selection of the best being represented. This wall is of considerable length, and the trees yield a supply of fruit far exceeding what would be expected from a garden of this size. There is scarcely a foot of unoccupied space to be seen, and the trees are now in fine bearing condition. This has been a most valuable addition to the resources of the establishment, and as the majority of the trees have been planted during Mr. Bates' period of management, in this respect alone he has done good work. The small fruits have been abundant, and the orchard trees are looking well, Pears being abundant. Apples are also plentiful, but not to the extent the wonderful show of bloom led many to expect. The vegetable crops have had a trying season, but with the assistance of a plentiful supply of water the evil effects have to some extent been overcome, though Onions and root crops generally are necessarily small. The care of a thoroughly practical superintendent, who finds a pleasure in his employment, is evident in every department, and no one can spend an hour with Mr. Bates without recognising him as a true gardener.

A short distance farther down the same road brings the visitor to the historically famous garden at

#### POPE'S VILLA.

The present erection is of ornamental construction, and is said to be placed very near to the site of the poet's original villa, which has been long since swept away. Nearly a century and a half have elapsed since Alexander Pope died, and many changes have occurred in his favourite garden in that time, but in some respects its beauty may be said to be more fully developed and perfected than he ever saw it. Trees that were planted in his time or shortly before, like the Cedars of Lebanon, have attained to majestic proportions, while doubtless some that were then in their prime have disappeared, such as the poet's Weeping Willow, of which an old trunk is still preserved in the grotto. Many of Pope's letters and poems prove him to have taken the deepest interest in his garden, and much of his time was spent in devising improvements. He endeavoured to introduce as much variety as possible and to "follow Nature," and he says—

"Those rules of old discovered, not devised,  
Are Nature still, but Nature mch'dised.  
Nature, like Liberty, is but restrained  
By the same law which first herself ordain'd."

It is recorded by biographers that Pope purchased the garden and villa with a portion of £5000 he realised by the sale of his translation of Homer's Iliad, a respectable sum for successful authors to secure even at the present time. He seems to have derived considerable pleasure from his garden, for in writing to a friend he says, "No ideas you could form in the winter can make you imagine what Twickenham is in the summer season. Our river glitters beneath an unclouded sun, at the same time that its banks retain the verdure of the showers; our gardens are offering their first nose-gays; our trees, like new acquaintances brought together, are stretching their arms to meet each other, and growing nearer and nearer every hour; the birds are paying their thanksgiving songs for the new habitations I have made them; my building rises high enough to attract the eye and curiosity of the passenger from the river, when beholding a mixture of beauty and ruin, he inquires what house is rising or what church is falling; so little taste have our common Tritons of Vitruvius, whatever delight the poetical god of the river may take in reflecting on its streams my Tuscan portico or Ionic pilasters." The celebrated grotto, of which so much has been written, is practically a passage constructed for convenience beneath the Cross Deep Road, and connecting the portion of the garden near the river with another portion and the kitchen garden beyond. Though it is not so ornate now as when fresh from its designer's hand, it is considerably more than "a mere damp subway," as a recent writer has dubbed it.

After Pope's death the villa passed into the possession of Lady, subsequently Baroness Howe, the daughter of Admiral Howe, and though many alterations were effected during her residence, much of the nature of despoiling, the place became famous for brilliant garden parties, and especially for the great fêtes on the anniversary of "the glorious 1st of June." Subsequently to that period the garden passed into other hands; it was, with the house, several times offered for sale, and finally the present villa (fig. 15) was erected, which is now in the occupation of Henry Labouchere, Esq., M.P.

The garden is not a large one, and its beauty consists in its wealth of trees and shrubs, with verdant velvety lawns. From the river frontage a charming view is obtained up and down the river; through the grotto the other garden is reached, a delightful sylvan retreat in which both Conifers and deciduous trees thrive with equal luxuriance. There are several grand Beeches, graceful Deodars, and Cedars of Lebanon,



one of the latter being of extraordinary size, and could scarcely be surpassed for its symmetrical proportions. It is difficult to estimate the age of such trees, but it is supposed to be contemporaneous with several others in the immediate neighbourhood—namely, about 200 years old. I have seen some of the grandest Cedars in Britain, including those at Warwick Castle, but do not remember seeing so evenly developed a specimen as this. Beyond is the kitchen garden and orchard, which, like the other portion, is kept in excellent condition by the gardener, Mr. Fitzwater, who takes considerable pride in the interesting garden under his charge. At the end of that the "wilderness" is reached, and another grotto, where there has been a passage beneath a second road to what may be termed a third garden, now separated.

The most beautiful portion of the garden is that entered from the first grotto, and it was a happy idea on the part of Mrs. Labouehere recently to initiate an outdoor performance of Shakespeare's "Midsummer Night's Dream" in such a situation. The first production provided for a large company of friends gave so much satisfaction that a second was held on Saturday evening (August 6th), the proceeds of which are to be given to the Charing Cross Hospital. Many gardeners are enthusiastic Shakespearian readers, and I know at least one who, besides being clever in his profession, has attained some fame in public Shakespearian re-

stead of substituting such an unlikely flower as the Cockscomb.—  
L. CASTLE.

#### FURNISHING VASES WHEN THE FLOWERS ARE FEW.

PERSONS who possess small gardens (and who having probably nursed every plant affectionately, cannot bear to think of depriving it of its beauty, even to remove that gayness to the drawing-room vases), may be glad to hear how to gather flowers with the smallest waste, and how to arrange them to make the greatest show.

The rules for this are very simple, though a design for it is impossible, as so much depends on the arranger's taste and lightness of touch in placing the flowers; so that even if I could accurately describe the effect of a well-arranged vase, it would become stiff from the mere restraint of copying.

My best advice in a case like this would be to take in the first place abundance of green if the nosegay is to be of solid style. In that case it does not much matter what the green may be—Myrtle, Pelargonium, Privet, Box or Laurustinus, Carrot leaves, and even in winter the early Kale leaves. Asparagus, too, in summer is excessively pretty, and looks like a plant of a Heath; and from the woods and hedgerows, if one is in

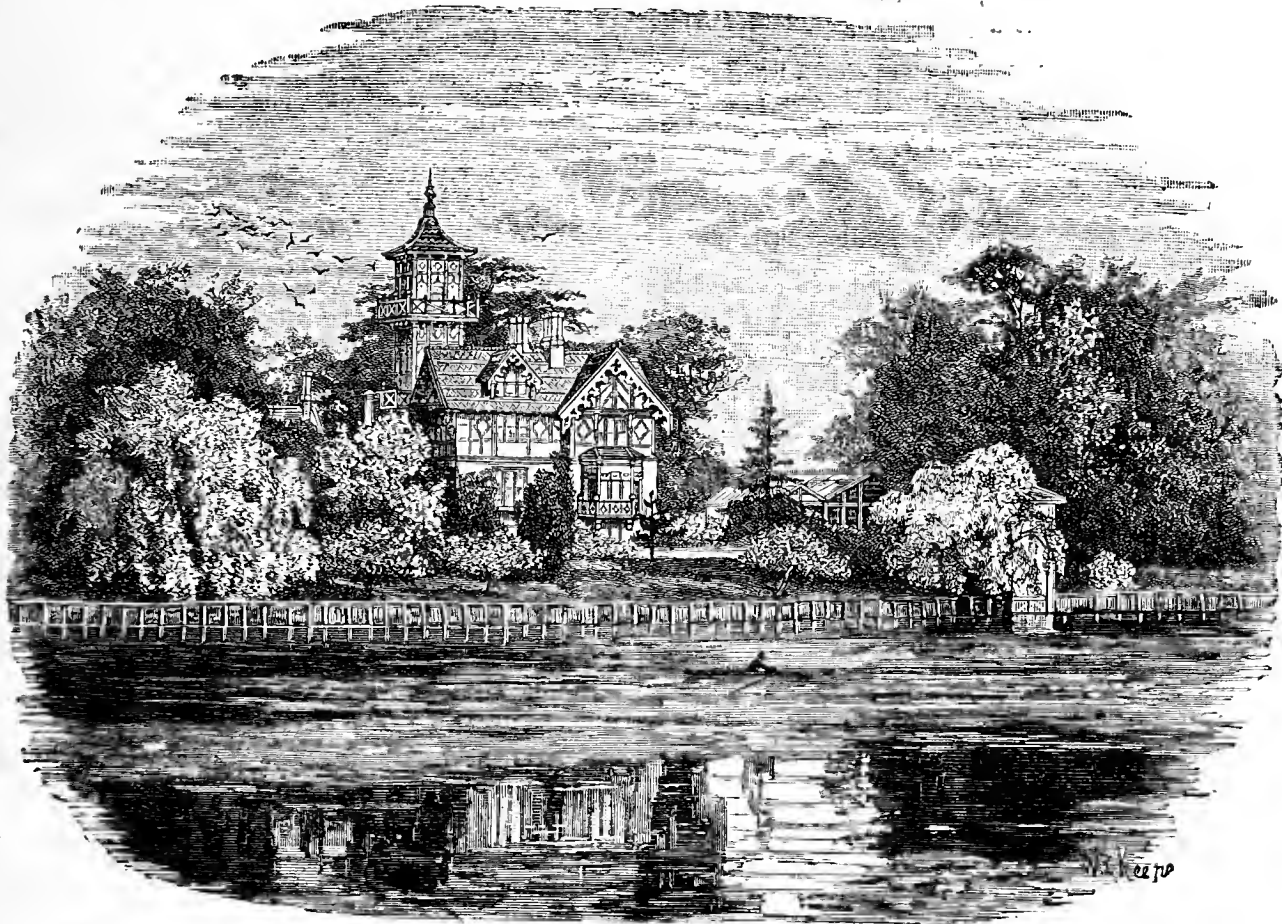

FIG. 15.—POPE'S VILLA, TWICKENHAM.

citals. All such could perhaps form some idea of "The Midsummer Night's Dream" performed in a picturesque tree-embowered garden on a warm clear summer's night by a selection of talented ladies and gentlemen. Well might an able critic say, "This is how Shakespeare would have wished it to be seen." A grand old Beech tree was chosen as the central portion of the stage, and beneath its widely spreading branches the chief scenes were enacted, while stretching away on each side were the forest glades through which the respective personages approached and departed. Amongst the branches of the Beech were suspended two electric lamps, which shed a soft light upon the lawn, the leaves acting as natural reflectors, and cleverly arranged, so that a powerful glare was not anywhere perceptible. The turf was banked in places with Ferns and flowers in profusion, adding greatly to the beauty of the spectacle which has been described as "a succession of pictures, a fanciful panorama of poetic conceits, in a word a delightful dream which none present will ever forget." The principal parts were taken by Miss Fortescue (Hermia), Miss Kate Vaughan (Titania), Miss Dorothy Dene (Helena), Lady Archibald Campbell (Oberon), and Miss Norreys (Puck); Mr. Claude Ponsonby (Lysander), Mr. Luxmore Marshall (Demetrius), and Mr. George Augustus Sala (Bottom the Weaver).

There has been much dispute about the various flowers referred to by Shakespeare, but "the little western flower" mentioned by Oberon, and in which passage the poet is supposed to have paid a special compliment to Queen Elizabeth, has generally been regarded as the Heart-ease, which could have been easily obtained on the occasion named, in-

the country, innumerable green things can easily be brought in, of which amongst the prettiest are green moss tresses.

Having an abundant foundation of green—the green itself being arranged as carefully for the effects of light and dark as though it were the bouquet; making it, however, not in the broken lights, but well massed together; the next thing to be done is to see what flowers the garden can afford us. As a general rule all flowers of thin texture, and most especially so those which combine with it a rather pale and delicate colour, or which elose up quickly, are not only sources of annoyance to the garden-bed, but of no avail whatever to the drawing-room vase. They are tempting to gather, because they look at first so pretty in one's hand, seen alone and closely, and because one fancies they will not be very badly missed considering they are small. But very much mistaken are both of these ideas. They are missed a good deal if gathered in any quantity, since generally they grow low, and are filling up some corner, and certainly they do not improve the bouquet; for being thin and wanting in vividness of colour, if they do not shut up at once or tumble off the stalk they often are more apt to do harm than good.

The larger flowers, of course, must be gathered with grave consideration, and they must be gathered by someone who has the vase in view and guesses generally at how she wants to fill it. Let us suppose, for instance, a garden to contain, as many gardens do, scarlet, pink, and white bedding-out Pelargoniums, Verbenas, Carnations, China Asters, Roses, and Calceolarias. Petunias we will not speak of, as they seldom

answer well for gathering. *Nemophila*, *Convolvulus*, &c., are too fragile to be worth picking; and out of the others also there is an abundant choice. The chief thing to avoid is gathering scarlet and pink *Pelargoniums*, or scarlet and pink *Verbenas*. Pink and dark rose colour do well in both together, but the pink and scarlet in the same flowers are so much alike that they want to be more or less so, and in looking at the nosegay one unconsciously compares them.

A good-sized vase well filled with green for the solid part and edges, would look very well with several white or very light flowers put in in different places dotting about the vase, then working to one side of the white, but by no means at regular distances (at least, for a first attempt, as in very mixed arrangements any degree of form is difficult to do well.) Perhaps, at the back or side of one of the lighter flowers a piece of dark *Verbena*, a *Clove Carnation*, a red *Rose*, or even two or three such flowers carelessly grouped together, and generally the better for being of the same kind. (I should mention that I only name the light flowers to give myself a starting-point from which I can describe.) Say that above a cluster of crimson *Roses* one had two or three pieces of white and pale pink *Verbena* slightly verging towards the light flower next door. Underneath, on the shady side, if anywhere, the purple or mauve *Verbena*, lighted up in its turn, when the time comes for lighting, which is only at the very last, with a little piece of velvety scarlet *Pelargonium*, and it is the more essential to choose a deep full scarlet because of the purple being so dead that a paler, thinner colour would look poor by its side.

These purple *Verbenas* must be only looked on as shades; a flower-glass will look no fuller for them, though sometimes they will answer in filling up a shadow. These dark flowers, however, should always be arranged not to overshadow, but to be enlivened by the lighter flowers near.

The centre of the vase will probably have a cluster of *Roses* or a fine *Pelargonium*, which shows extremely well if surrounded with four of its own good-sized leaves. If *Roses* are used there, one or two little pieces of scarlet *Geranium* often prove effective for lighting up the centre. A *Water Lily* is particularly beautiful when it can be had. So are *Passion Flowers* well relieved with scarlet or with crimson. But the very centre should be always some grandish flower or a distinct light sort of group-light, not in colour so much as in arrangement. Spikes of *Mignonette* do better in the middle than in any other place. A good group of *Carnations* answers beautifully, and sometimes one may make a merit of a difference, just as at another time one tries to be all alike. So five or six splendid *Carnations* of various stripes and colours may look very striking.

When the general effect of the nearly finished vase is that the edge is darker than the centre, a few little sprays of yellow *Calceolaria* may be introduced with very great advantage, and it will, better than any flower I know, light up the vase without toning down as white does, or reddening the colour too much as scarlet does, when not wanted for its own sake. The yellow may have put in against it a good-sized spray of the dark orange brown sort of *Calceolaria*, which has often a very good effect, and decides the yellow to be really gold colour. If the centre should be the heaviest, it may probably require the addition of a little red or pink or white to give it liveliness, as well as a little yellow to give the required light. Light and gay, in this instance, having a different meaning, as may easily be seen by substituting scarlet *Pelargoniums* for the bright yellow flower, when it will look rather darker than it did before.

The lights must not be too numerous, nor too large, nor too near the actual centre. I think for them it is best to slip in the flower (the stalk smooth and deprived of leaves), and then to cut off with sharp scissors any too many of the "Ladies' Slippers."

China *Asters*, *Stocks*, and dull-coloured *Verbenas* should never advance much into notice. Sometimes a good China *Aster* may, but generally vases are better with lighter-formed flowers in the more conspicuous places, and when there is a choice, I think if there is much scarlet in the vase the yellow-tinged light flowers do better than those of a pinkish or bluish hue, which in their turn again answer best where the chief tone is crimson.—D. G.

## ROYAL HORTICULTURAL SOCIETY.

AUGUST 9TH.

THE meeting on Tuesday was rendered attractive by the collection of hardy flowers, *Gladiolus* and *Hollyhocks* provided. There were also some good vegetables, and several interesting exhibits of fruits.

FRUIT COMMITTEE.—Present: T. Francis Rivers, Esq., in the chair, and Messrs. Harrison Weir, James Smith, G. Norman, Sidney Ford, J. Roberts, J. Burnell, J. Fitt, Phillip Crowley, G. Bunyard, and R. D. Blackmore. Mr. W. Carmichael, Bognor Park Gardens, Pulborough, showed samples of a seedling *Grape*, a cross between *Muscat of Alexandria* and *Black Hamburg*, raised from seed sown in April, 1884. The berries were of a reddish colour like *Muscat Champion*, and the Committee did not express any opinion concerning it. Mr. Carmichael also sent a seedling green-fleshed *Melon*, named *Duke of Buccleuch*. Mr. Denne, Gore Court Park, Sittingbourne, showed a dish of *Cherries* unnamed. Mr. C. Ross, Welford Park, Newbury, sent a seedling green-fleshed *Melon* of fair flavour and well netted. Mr. W. Divers, Ketton Hall Gardens, and Mr. W. Palmer, Thames Ditton House Gardens, also sent seedling *Melons*.

Messrs. Rivers & Son, Sawbridgeworth, were awarded a cultural commendation for four dishes of *Cherries*, *Bigarreau Monstrueuse de Mezel*, *Geant d'Hedelfingen*, late *Black Bigarreau*, and *Emperor Francis* (certificated). W. Roupell, Esq., Streatham Hill, showed six bunches of the *Purple Constantia Grape* (*Frontignan*), from which the liqueur wine is made at the

Cape. It is grown in 13-inch pots on warm pipes in a sunny situation. The flavour was very rich. Some good examples of *Muscat Hamburg* grafted on *Black Hamburg* were also shown.

Messrs. J. Veitch & Sons, Chelsea, were awarded a silver Banksian medal for sixty dishes of fine *Gooseberries*, representing a great number of distinct varieties, white, green, and red. Some of the more notable varieties, *Mount Pleasant*, *Dan's Mistake*, *Leviathan*, *Alma*, *Leveller*, *Pilot*, *Leader*, *Tiger*, *Hepburn's Prolific*, *Broom Girl*, *Keens' Seedling*, *Surprise*, *Trumpeter*, *Snowdrop*, *Green Overall*, *Crown Bob*, *Warrington*, *Snowdrift*, *Eagle*, *Sally*, and *Green Gascoigne*. Several plants were also shown in pots. They also had several dishes of *Apples*, *Plums*, *Green Gages*, *Oullins Golden Gage*, *Alexander Peaches*, and *Pears*.

Certificates were awarded to the following:—

*Apple Cooling's Beauty of Bath* (G. Cooling & Sons, Bath).—A pretty *Apple* of medium size, 2½ in. across, 1½ deep, eye closed in a deep basin, stalk short, thick, in a deep depression, colour bright red, with numerous whitish dots. Flesh firm, yellowish, of a brisk subacid flavour, rather suggestive of the *Devonshire Quarrenden*. It is said to be fit for table by the middle of July.

*Cherry Emperor Francis* (Rivers & Son).—A fine heart-shaped fruit of a bright red colour, firm flesh, of excellent flavour.

*Pear Madlle. de Solange* (J. Veitch & Sons).—A new variety, the fruits small, green, nearly globular, with a large open eye, and a protuberance at the side of the stalk. It was ripe, juicy, and of good flavour.

SPECIAL PRIZES.—Mr. Fidler's prize for a collection of vegetables brought two competitors, Mr. C. J. Waite winning first honours with admirable samples of *Pen-y-Byd Marrows*, *Intermediate Carrots*, *Snowdrop* and *Fidler's Clipper Potatoes*, *Reading Perfection Tomatoes*, *Carter's Jubilee* and *Ne Plus Ultra Beans*, *Veitch's Autumn Giant Cauliflowers*, *Reading Allheart Cabbages*, *R-ading Conqueror Peas*, *Early Nantes Carrots*, *White Leviathan Onions*, *Moore's Cream Marrows*, *Green Globe Artichokes*, and *Sutton's Royal Jubilee Peas*. Mr. T. A. Beckett was second with less even samples. The prizes for dishes of Fidler's new *Reading Conqueror Pea* were gained by Mr. T. A. Beckett, Cole Hatch Farm, Amersham, Mr. C. J. Waite and Mr. H. Marriott. The prizes for *Fidler's Defiance Melon* were won by Mr. C. Ross, Mr. J. G. Dean, and Mr. W. Woolford, there being five competitors.

Messrs. Webb & Sons' prize for a collection of vegetables was won by Mr. C. J. Waite with beautiful samples of *Intermediate Carrots*, *Canadian Wonder Beans*, and *White Leviathan Onions*.

FLORAL COMMITTEE.—Present: G. F. Wilson, Esq., in the chair, and Messrs. J. Douglas, W. Goldring, R. Dean, J. Dominy, H. M. Pollett, A. E. Lendy, J. O'Brien, G. Paul, J. Fraser, J. Walker, W. Holmes, B. Wynne, E. Hill, and Dr. M. T. Masters. Mr. T. S. Ware, Tottenham, exhibited a bright collection of hardy flowers, comprising *Gladiolus*, *Iceland Poppies*, *Gaillardias*, *Lilies*, and the orange coloured *Asclepias tuberosa* (a silver Banksian medal was awarded). Messrs. Kelway & Son, Langport, Somerset, had a grand collection of about 150 spikes of *Gladioli*, representing a selection of their numerous choice delicate and richly coloured varieties, several of which were certificated, and a silver-gilt Banksian medal was awarded for the collection. Messrs. H. Cannell & Sons, Swanley, showed two plants of the yellow fruited *Capsicum Mango Pepper*, a large collection of handsome single and double *Tuberous Begonias*, three pretty *Gloxinias*, and a stand of a new double *Zonal Pelargonium*, purple and scarlet (vote of thanks). Messrs. Webb & Brand, Saffron Walden, sent a collection of *Hollyhocks* of capital quality. A vote of thanks and two certificates were awarded. Messrs. Dobbie & Co., Rothsay, N.B., sent some extremely fine *African Marigolds* and *Violas*, several certificates being awarded. Messrs. J. Carter & Co., High Holborn, had a vote of thanks for eight flowers of *Japanese Irises*, representing some beautiful varieties. They also had plants of the double white *Pyrethrum Parthenium Snowball*. Mr. F. T. Smith, West Dulwich, was adjudged a vote of thanks for two stands of *Hollyhocks*, comprising sixty-four good blooms.

F. G. Tautz, Esq., Studley House, Hammersmith (gardener, Mr. J. C. Cowley), had a small group of *Orchids*, including *Cypripedium leucorrhodum*, *C. Ashburtonianum*, *C. orphanum* (certificated), *C. Tonsm.*, and a species like *C. concolor* from Siam. *Cattleya Warneri rubra* had two large and highly coloured flowers, *Mitonia spectabilis bicolor* was white with a crimson central blotch in the lip, and *Mitonia Palusoni concolor* of a dark purplish hue. Mr. W. Divers, Ketton Hall Gardens, Stamford, showed blooms of *Carnation Pride of Ketton*, of a soft pink colour. Mr. P. McKenzie McKie, Teddington, showed blooms of a pale pink double *Petunia* named *Dorothy*; and Mr. R. Maher, Yattenden Court, near Newbury, showed blooms of *Picotee Orlando*, a yellow ground, flaked red. Mr. W. Palmer, The Gardens, Thames Ditton House, Surrey, had some fine blooms of *Magnolia grandiflora* and several new *Coleuses*, for which votes of thanks were accorded.

The prizes offered by W. Roupell, Esq., for fifty spikes of double *Hollyhocks* only brought one exhibitor, Mr. James Blundell, West Dulwich, who had a fine collection of spikes, the flowers large and varied in colour, white, cream, pink, yellow, orange, crimson, and purple.

### CERTIFICATED PLANTS.

*Catasetum Bungerothi* (Baron Schroder).—The plant shown was the valuable one sold at Stevens' Rooms last year, and had a raceme of ten large ivory-white flowers. We gave an illustration of this remarkable *Oroid* in this Journal, page 563, December 23rd, 1886.

*Saccolabium Heathi* (Baron Schroder).—A charming species, with a long several graceful raceme of pure white flowers.

*Cypripedium orphanum* (F. G. Tautz).—A beautiful hybrid of unknown parentage, the dorsal sepal broad white veined with green in the centre, and purplish towards the sides; the petals about 2 inches long, half an inch broad, the margin even, a few dark hairs at the base, with a dark central vein, and a purplish tint in the other portion. The lip is well proportioned and rounded, of a rosy purple hue, bright and pretty.

*African Marigold Lemon Queen* (Dobbie & Co.).—Blooms very large and solid, 4½ inches across and 3 inches deep, globular and pale yellow.

*African Marigold Prince of Orange* (Dobbie & Co.).—Blooms of similar size to the above, of a rich orange colour, very handsome.

*Viola Lucy Ashton* (Dobbie & Co.).—A distinct variety, flowers white in the centre, veined purple, and broadly margined with pale purple



*Hollyhock William Archer* (Webb & Brand).—Blooms large, full, and very deep, dark crimson.

*Hollyhock Scarlet Gem* (Wehh & Brand).—Blooms full and of good shape, with grand petals, dark scarlet.

*Gladiolus William Roupell* (Kelway & Son).—A brilliant scarlet variety, flowers of great size and fine substance.

*Gladiolus Princess Royal* (Kelway & Son).—A charming variety, white, streaked with bright rose, the flowers of immense size and excellent form.

*Gaillardia Wm. Kelway* (Kelway & Son).—A very large bloom,  $4\frac{1}{2}$  inches across, deep red, tipped with yellow; very distinct.

*Rose Paul's Single White Perpetual* (Paul & Son, Cheshunt).—A lovely variety, flowers  $2\frac{1}{2}$  inches across, white, with a faint pink tinge, very free and graceful.

## THE NATIONAL CARNATION AND PICOTEE SOCIETY (NORTHERN SECTION).

THE annual Exhibition took place in the Botanical Gardens annexe of the Jubilee Exhibition Palace at Manchester on the 5th inst., and was the smallest in extent of the three Carnation and Picotee feasts that has been provided this season. With but few exceptions the flowers were weak in size, though generally bright in colour; the excessive dryness of the atmosphere and the great heat appeared to have operated in preventing the blooms from bleaching properly, and the grounds were what the northern florists term "foggy." Excepting in the case of Mr. Robert Lord's flowers, who as at Oxford won the second, showed in splendid form, there was a marked absence of high-class quality, a characteristic so noticeable at Oxford; still the northern growers did their best in the face of great disadvantages. For some reason the classes for single blooms were struck out of the schedule, a circumstance that tended to limit the area of the Exhibition still more. No southern grower competed in any of the classes with the exception of Mr. C. Turner of Slough.

The principal class was for twelve Carnations, dissimilar, open to all; five prizes were offered, and there being this number of competitors. Mr. Robert Lord, florist, Hole Bottom, Todmorden, followed up his success at Oxford by being placed first with a collection of excellent quality, having C.B. Master Fred, very fine; P.P.B. William Skirving, S.B. Fred, C.B. Thomas Moore, S.B. Robert Lord, R.F. Rob Roy, C.B. Shirley Hibberd, S.F. Henry Cannell, P.P.B. Squire Llewelyn, P.F. James Douglas, S.F. Tom Lord, and S.B. Admiral Curzon, the names being read across the stand from left to right. Second Mr. B. Simonite, Rough Bank, Sbeffield, with S.B. George, P.P.B. Seedling, P.F. James Douglas, R.F. Seedling, P.F. Seedling, S.F. Seedling, S.B. Seedling, R.F. Sybil, S.B. Admiral Curzon, R.F. Crista Galli, S.F. Seedling, and P.F. George Melville. Third, Mr. J. Beswick, Middleton. Fourth, Mr. P. Law, Rochdale. Fifth, Mr. Geo. Geggie, Waterloo Nursery, Bury. In the class for twelve dissimilar Picotees there were the same number of prizes and exhibitors. Here Mr. R. Lord was again first with a stand of flowers remarkable for their purity and exquisite marking, consisting of H. Red E. Morna, F. L. Rose E. Mr. Payne, L. Red E. Thomas William, H. Rose E. Lady Louisa Abercrombie, H.S.E. Mr. Sharpe, L.P.E. Ann Lord, L. Rose E. Mr. Aldcroft, H. Red E. John Smith, H.P.E. Mrs. A. Chancellor, L.P.E. Cynthia, L.P.E. Clara Penson, and H.P.E. Zerlina. Second, Mr. J. Beswick, Middleton, with H. Red E. Brunette, L.P.E. Clara Penson, L. Rose E. Daisy, H.P.E. Tinnie, L. Rose E. Liddington's Favourite, H.P.E. Muriel, H.P.E. Mr. Niven, L.P.E. Miss Harland, L. Red E. Thomas William, H.P.E. Zerlina, and L.P.E. Nymph. Third, Mr. B. Simonite. Fourth, Mr. F. Law. Fifth, Mr. Geo. Geggie.

There were nine exhibitors of twelve Carnations, nine or ten to be dissimilar, and there were nine competitors for five prizes. Here Mr. John Whitham, Hebden Bridge, Yorkshire, was first with C.B. Master Fred, S.B. Admiral Curzon, P.P.B. William Skirving, S.B. Fred, S.B. Thomas Storer, P.F. Florence Nightingale, R.T. Crista Galli, P.P.B. Thomas Anstiss, S.B. Robert Lord, P.P.B. William Skirving, S.B. Thomas Storer, and S.F. Tom Lord. Second, Mr. T. Law, with P.F. James Douglas, S.B. Edward Adams, R.F. Sybil, P.F. Mayor of Nottingham, R.F. John Keet, S.B. Master Fred, P.F. Earl of Wilton, S.F. Henry Cannell, S.B. Admiral Curzon, R.F. John Keet, S.F. Sportsman, and P.P.B. Sir Garnet Wolseley. Third, Mr. W. Taylor, Middleton. Fourth, Mr. John Whittaker, Royton. Fifth, Mr. J. Thorinley, Middleton. There were six exhibitors of twelve Picotees, nine at least to be dissimilar, and five prizes were offered, this and the preceding class being open only to growers of five hundred pairs or less. Here Mr. John Whitham was again first with H. Red E. Brunette, H.P.E. Zerlina, H. Rose E. Lady Louisa, L. Red E. Thomas William, H.P.E. Mr. A. Chancellor, L. Rose E. Favourite, H. Rose E. Fanny Helen, H.P.E. Mr. A. Chancellor, L.P.E. Ann Lord, H. Scarlet E. Mrs. Sharpe, L.P.E. Mary, and H. Rose E. Mr. Payne. Second, Mr. W. Taylor, with H. Red E. Brunette, H.P.E. Mr. Summers, H. Red E. William Summers, L. Rose E. Favourite, L.P.E. Ann Lord, L. Red E. Thomas William, H.P.E. Mr. A. Chancellor, L.P.E. Ann Lord, L. Rose E. Miss Gorton, H.P.E. Zerlina, L. Red E. Thomas William, and H.P.E. Mr. A. Chancellor. Third, Mr. R. Sydenham, Birmingham. Fourth, Mr. E. Shaw, Moston, Manchester. Fifth, Mr. J. Thornley.

Then followed two classes, each for six Carnations and six Picotees, dissimilar, six prizes being offered for growers of 250 pairs or less. There were seven competitors with six Carnations, Mr. F. Helliwell, The Hollins, Todmorden, being first with C.B. Master Fred, P.P.B. William Skirving, P.F. James Douglas, S.F. Tom Chapman, S.B. Admiral Curzon, and R. F. Crista Galli. Second, Mr. Maddocks, Loffhouse Hall, Wakefield, with C.B. Master Fred, S.B. John Hines, R.F. Crista Galli, P.P.B. William Skirving, S.B. Mercury, C.B. Samuel Checkley. Third, S. Barlow, Esq., J.P., Stakebill House, Castleton, whose stand contained a brilliant bloom of his new S.B. Robert Houlgrave, which is regarded as a decided improvement upon Admiral Curzon, and which was awarded a first-class certificate of merit at Oxford. Fourth, Mr. W. Bleakley, Whitefields; fifth, Mr. Thomas Howard. In the class for six Picotees there were seven competitors, and Mr. T. Helliwell was placed first with H.P.E. Mrs. Niven, L. Red E. Thomas William, H. Rose E. Mrs. Lord, H. Rose E. Mrs. Payne, H. Red E. John Smith, and H. Rose E. Constance Heron. Second, Mr. Bleakley with L. Rose E. Miss Horner, H. Red E. J. B. Bryant, L. Red E. Thomas William, L. Rose E.

Favourite, H.P.E. Zerlina, and L. Red E. Mr. Gorton. Third, Mr. Maddocks; fourth, Mr. Edwards; fifth, S. Barlow, Esq., J.P.

There were four stands of twelve self Carnations, the striped and flaked varieties being excluded, which materially tended to narrow the competition. In this class Mr. L. Law was first with Mrs. Hyde, white; George Henry, pink; Squire Meynell, purple; Pride of Penhurst, yellow; Henry Cannell, scarlet; and unnamed seedlings. Second, Mr. Geo. Geggie, with some good flowers, but all unnamed. Third, W. W. Prescott, Manchester. The fourth prize was withheld.

Then followed eight Jubilee prizes for twelve miscellaneous Carnations and Picotees of any variety, there being twelve competitors; and here Mr. R. Lord was again first with C.B. Master Fred, Light Rose E. Favourite, C.B. J. D. Hextall, H. Rose E. Mrs. Payne, H. Rose E. Lady Louisa, Scarlet Self John Witham, R.F. Rob Roy, Self King of Yellows, H. Red E. Dr. Epps, White Self The Bride, H. Rose Royal Visit, and S.B. Admiral Curzon. Second, Mr. Charles Turner, Royal Nursery, Slough, with L.R.E. Favourite, P.P.B. Rifleman, L.P.E. McNicoll, R.F. Rob Roy, S.B. John Hines, H. Rose E. Mrs. Payne, S.B. Robert Lord, H. Red E. Dr. Epps, L.P.E. Constance, P.P.B. Mrs. Barlow, H. Red E. Silvia, L.P.E. Mary. Third, Mr. J. Beswick. Fourth, S. Barlow, Esq., J.P. Fifth, Mr. T. Law.

The premier Carnation was C.B. Master Fred, a fine bright-coloured flower, shown by Mr. R. Lord. The premier Picotee was Light Purple Edge Baroness Burdett Coutts, shown by Mr. C. Turner.

First-class certificates of merit were awarded to Mr. C. Turner for the following ground Picotees—viz., Almira, Annie Douglas, and Terra Cotta, and for Self Carnation Rose Celestial, a very fine pale pink flower. The two former were raised by Mr. J. Douglas, and are of very fine quality. Mr. Turner also had Colonial Beauty and Dorothy, two promising and distinct Yellow Ground Picotees. S. Barlow, Esq., had a dozen blooms of S.B. Carnation Robert Houlgrave, which received a first-class certificate of merit at the northern meeting in 1886. Mr. F. Law, Carnation Gardens, Rochdale, had a large quantity of Carnations, bazaar, flaked, self, and fancy in great variety; also many types of Picotees, and a stand of six blooms of Dahlias that were greatly admired. All were highly commended by the Judges.

## HORTICULTURAL SHOWS.

FROME.—AUGUST 1ST.

THIS was altogether superior in every respect to its predecessors, and the fixture promises to increase in popularity both with exhibitors and visitors. A considerable number of classes are provided, and fairly liberal prizes are given, these attracting a close and good competition, the local exhibitors, however, in many instances, managing to hold their own. The Honorary Secretaries are Messrs. W. H. Frankham and H. Haley, these gentlemen, with the assistance of a practical working committee, carrying out the various requisite details in a very creditable manner. The weather was most favourable, and the attendance of visitors good.

The best prizes in the plant classes were offered for groups arranged for effect, to occupy a space not to exceed 12 feet by 6 feet. Of these there were three exhibitors, and each made a very effective display. The Marquis of Bath (W. Pratt, gardener) Longleat, was well first, his group being especially rich in Crotons, such beautiful sorts as aigburthensis, Neumannii, Evansianus, Thomsoni, Youngi, rubellus, majesticus, mosaicus, Disraeli, Warreni, interruptus aureus, Andreanus, fasciatus, and interruptus elegantissimus, being in excellent condition. A background of large Palms, and a groundwork of Adiantums showed these and other well-grown plants off to the best advantage, and the group came in for a good share of admiration. The second prize was awarded to H. Haley, Esq. Frome, who had a fine background of freely flowered Fuchsias, and an abundance of well-grown Ferns, Lillium auratum, and other plants. John Baily, Esq. (B. Hopkins, gardener) Fairlawn, Frome, was a close third, his group including numerous Caladiums, Crotons, Ferns, Palms, and Fuchsias, all in good condition. Flowering plants were not extensively shown, Major Clarke (G. Tucker, gardener) Trowbridge, was easily first, his group including good specimens of Allamandas Hendersoni and nobilis, Statice profusa, Oncidium flexuosum, Stephanotis floribunda, and Anthurium Sebretianum. John Baily, Esq., took the second prize, a Lillium auratum and Plumbago capensis showing well in his collection. Major Clarke was also first for a single specimen flowering plant, having a perfectly grown, beautifully coloured Bougainvillea glabra. The Marquis of Bath was second with Oncidium flexuosum in good condition, and A. G. Hayman, Esq. (S. Andrews, gardener) Hapsford, Frome, third with a prettily trained and flowered Hoya carnosa.

Fine foliage plants were shown by several growers, but were not of very high class. The Marquis of Bath was first for six, these including large specimens of Latania borbonica, Scaevola elegans, Kentia canterburyana, and Croton Warreni; John Bailey, Esq., followed, his Croton interruptus aureus being very beautiful; and the third prize was awarded to W. H. Laverton, Esq. (W. Prosser, gardener), Westbury. Ferns were both numerous and good. Major Clarke was well first for twelve varieties, among these being very healthy and good Dicksonias, Gymnogrammas, Adiantums, and Davallias. The second prize was won by C. Bailey, Esq., Welshmill, Frome, with a very creditable lot of plants; and J. D. Knight, Esq. (T. Edwards, gardener), Frome, had the remaining prize. With six varieties Mrs. Gouldsmith (G. Pymm, gardener), Trowbridge was well first, included in this lot being a good Adiantum farleyense; John Baily, Esq., was second; and Mrs. Simkins (E. J. Wilcox, gardener), Wallbridge House, Frome, third, both have medium sized healthy plants. Several exhibitors staged extra good Coleuses, those which gained the first prize for Captain Tucker (W. Bull, gardener) Keyford House, Frome, being very beautifully coloured.

There were only two exhibitors of small collections of Orchids. Mrs. Gouldsmith was first, such sorts as Cattleyas Forbesi, Gaskelliana, Loddigesii, and Mendelli being very attractive. The Earl of Cork (W. Iggulden, gardener), Marston House, Frome, had Aerides odoratum, Lælia purpurata, Oncidium flexuosum, and Epidendrum vitellinum in good condition, and received the second prize. Tuberous Begonias were extensively shown, and in good variety. Major Clarke was first, and Captain Tucker second. Gloxinias were shown by E. R. Trotman, Esq., The Elms, Frome, the second



prize going to G. Hayman, Esq., and several other good lots were shown. Captain Tucker was first for six trained Zonal Pelargoniums, and which were very healthy and well flowered, the second prize going to C. Baily, Esq., and the third to J. G. Knight, Esq., these also having very creditable plants. The best six Fuchsias were shown by C. Baily, Esq., and the same exhibitor was also first for four plants; a second prize in each instance going to J. D. Knight, Esq., the plants generally being much better than hitherto shown at Frome.

The Earl of Cork was easily first for a stand of twelve bunches of choice cut flowers, Dipladenias in variety, Ixoras, Allamandas, Orchids, Eucharises, and other kinds being well set off by fronds of Maidenhair Fern. W. H. Laverton, Esq., was a creditable second, and Major Tucker third. The cut Roses were quite a feature in the Show, and so good were they that one well known exhibitor failed to take a prize in either class. The first prize for twenty-four varieties was won by Messrs. Keynes, Williams & Co., Salisbury, among these being large and fresh blooms of Madame Eugenie Verdier, C. Lefebvre, Penelope Mayo, Duke of Connaught, Louis Richard, A. K. Williams, A. Colomb, Madame Prosper Langier, and Niphotos. Messrs. G. Cooling & Sons, Bath, followed closely, their best being *Beaute de l'Europe*, August Rigotard, and Etienne Levet, Duchess of Bedford, Horace Vernet, A. K. Williams, and Dr. André. Mr. G. Humphries, Kington Langley, Chippenham, was a good third, in his stands being handsome blooms of A. Colomb, Dr. Andry, Niphotos, Pauline Labonte, Socrates, Innocente Pirola, and Reynolds Hole. With twelve varieties Messrs. G. Cooling & Sons were first, having such sorts as Her Majesty, Mons. E. Levet, Madame Verdier, C. Lefebvre, Perle des Jardins, A. K. Williams, Bouquet d'Or, Horace Vernet, and St. George in excellent condition. Messrs. Keynes, Williams & Co. were second, Ulrich Brunner, Maréchal Niel, Niphotos, C. Darwin, and Penelope Mayo being among the best, while the third prize was again won by Mr. G. Humphries. The last named exhibitor also had a capital lot of cut Dahlias, not for competition, these including medium-sized perfect blooms of Mrs. Gladstone Gaiety, John Wyatt, J. Stevens, H. W. Ward, Oracle, J. Ashby, Peacock, Reporter, and Mrs. Saunderson. The best collection of hardy annuals in bunches were shown by Mrs. Sinkins, and very excellent they were too. The Earl of Cork was first for a hand bouquet, and C. Bailey, Esq., second; and in the class for vases or epergnes Mr. Fred Dunn, Marston Gardens, Frome, was easily first, and C. Baily, Esq., second.

A medium-sized tent was devoted principally to the fruit classes, and a very creditable display was brought together. The Earl of Cork was well first for a collection of six varieties, these consisting of good Black Hamburg and Foster's Seedling Grapes, Queen Pine Apple, a fine Golden Gem Melon, good Royal George Peaches, and Lord Napier Nectarines. John Baily, Esq., was awarded the second prize, the Peaches and Nectarines in this collection being very good, while the third prize went to Mr. E. Every, Bath. With two bunches of black Grapes the Earl of Cork was first, staging Black Hamburg fine in bunch and berry and well finished. The Marquis of Bath took second prize with the same variety, only slightly inferior to those from Marston. John Baily, Esq., was third with very creditable Madresfield Court. In a corresponding class for white Grapes the Muscat of Alexandria from Longleat were first, the bunches and berries being much finer than those of the same variety from Marston, but they were not so well ripened. The third prize in this instance went to W. H. Laverton, Esq., for rather unripe Buckland Sweetwater. For a dish of Peaches John Baily, Esq., was easily first, having really grand fruit of what we believe to be Royal George. A. J. Hayman, Esq., was a good second, and Mrs. Gonldsmith third. The Earl of Cork was first for a Melon, and E. R. Trotman, Esq., second, both having fairly good fruit of Hero of Lockinge. Cherries, Gooseberries, Currants, and Apples were also shown extensively and in first-rate condition.

Vegetables were more plentiful and of better quality than anticipated. A. J. Hayman, Esq., was first for an unlimited collection (prizes given by Messrs. Sutton & Sons), included in which were good Telegraph Cucumbers, Duke of Albany and Latest of All Peas, Moore's Cream Vegetable Marrows, White Leviathan Onions, Large Red Tomatoes, Sutton's Seedling Potatoes, and a great variety of other vegetables all in good condition. Mr. T. Every, Bath, had several very good dishes, but was outnumbered by the first prizewinner, as well as by Mr. Meads, Frome, who took the third prize. Mr. J. Hall, Croscombe, was fourth. Mr. Every was first for a collection of salad, and C. Baily, Esq., for a collection of Potatoes, and several others showed good Potatoes. The best or freshest dish of Tomatoes was staged by the Earl of Cork; the second prize going to A. J. Hayman, Esq., both having Perfection in good condition. Mr. J. Cray, Frome, had a very good brace of Model Cucumber and was first, the second prize going to the Earl of Cork for the same variety. Several others showed Cucumbers, but in most instances they had been left too long on the plants.

#### LEICESTER.—AUGUST 2ND.

THIS, the second annual Show, held in the Abbey Park, was a decided success both as regards the exhibits, several of which had come on from Liverpool Show the previous day, and also as regards visitors, about 20,000 people having been admitted during the afternoon. This large number may be partly accounted for by the Show being held near to the Bank Holiday, and the fact that other attractions were provided also in the form of aquatic sports, the ascent of a large balloon with three people, a choice selection of music from four excellent bands, and last, but by no means least, the beautiful gardens and park in which the Show was held, proved a great attraction to many. To those who knew the place five years ago it must appear a most remarkable transformation to see this extensive park and gardens laid out in first-rate style, with plenty of good drives and walks, a piece of ornamental water, with rustic bridges, &c., some capital rockwork, a splendid collection of plants, shrubs, trees, and herbaceous plants in great numbers and variety, and probably the finest examples of carpet bedding seen in the midland or northern counties, one large bed with the Royal Arms being especially attractive. All this there is and more, where five years ago only a swamp existed; this certainly reflects the greatest credit on Mr. Burn, the able superintendent, who also carried out most successfully the arrangements for the Show, and made everyone thoroughly welcome. Being only the second show it is as yet quite in its infancy; but if it advances in growth according to its age it will soon be equal to any show in the kingdom.

It must have been rather surprising to many to see the shrubs and plants looking so well this dry season, and especially as some of the beds had large fissures in them 2 inches wide. The fact that the soil used when forming the beds was chiefly river dredgings accounts for its holding nature, and this season at any rate it appears to suit everything. The following gentlemen kindly acted as Judges:—Plants and cut flowers—Mr. Burton, from Messrs. Williams' nursery, and Rev. Mr. Pochin, Barkby, Leicester; fruit—Mr. O. Thomas, Chatsworth, Mr. Aitken, Kirkleatham Gardens, Redcar, and Mr. Elphinstone, Shipley Hall, Derby; vegetables—Mr. Cook, Quorn, Mr. Jno. McLean, Quorn, and Mr. Jas. Harrison, Leicester, and they deserve a word of congratulation for the successful way in which they performed their duties.

The exhibits were arranged in five large tents, each about 80 feet by 20. One of these was filled with seven groups of plants, arranged on the grass with a broad walk down the centre of the tent, and which presented a very chaste and pretty appearance. The first prize was awarded to Mr. Murray, gardener to S. Bennett, Esq., Holmdale, Leicester, whose group was well balanced with flowering and foliage plants, and looked light and graceful; second, Mr. Stephenson, gardener to J. Stafford, Esq., Elmsleigh Hall; third, Mr. Barry, gardener to F. Snow, Esq., Elmwood, with a very nice lot of plants, but rather too heavy in appearance. For eight stove and greenhouse plants the competition was very poor. First, Mr. Bolton, Barkby, who had a good *Plumbago capensis*, *Bougainvillea glabra*, *Croton Johannis*, *Cycas revoluta*, &c.; second, Mr. Murray, with much smaller plants. A nice lot of table plants of the usual kinds were shown in this tent, which also contained a group of Tomato Sunny Bank, exhibited by Vickers, Collyer & Co., very free fruiting, in small pots, much in the style of Nisbett's Victoria.

Entering the next tent we came at once to one of the principal attractions of the Show—viz., the collections of fruit exhibited for the Veitch Memorial medal, a strong competition, ten entries, but only six staging. Mr. Goodacre, Elvaston Castle, secured the medal and first prize with good Muscat of Alexandria Grapes and first-rate Hamburg ditto, a good Hero of Lockinge Melon, Loxford Hall Strawberries, and Circassian Cherries being the best of his other dishes; second, Mr. Edmonds, Bestwood, with good Madresfield Court and rather green Muscat Grapes, very fine Elruge Nectarines, and Early Grosse Mignonne Peaches, &c.; third, Mr. Hare, Wellington, Grantham, with smaller examples; fourth, Mr. Dawes, Temples, Newsham, Leeds, who had very good Madresfield Court Grapes and an enormous Melon over 2 feet in circumference. Most of the fruit classes were strongly contested. For six Peaches—First, Mr. Edmonds; second, Mr. Barry. Six Nectarines—First, Mr. Murray, with a very fine dish of Pine Apple; second, Mr. Edmonds, Elruge, also very fine. Eight lots of Hamburg Grapes were shown—First, Mr. Goodacre, with well-coloured bunches; second, Mr. Crawford. Muscats varied very much in quality, size, and ripeness—First, Mr. Roberts, gardener to H. Packe, Esq., Loughborough; second, Mr. Goodacre; third, Mr. Edmonds. In Class 87, any other black variety, Mr. Goodacre was first with two splendid bunches of Muscat Hamburgs. Strawberries were not very plentiful—Mr. Maynard, of Cole Orton, took first with a very fine dish of fruit. Pines were numerous and good, Mr. Goodacre taking first prize with a very fine Smooth Cayenne; second, Mr. J. Gough, Uxbridge; third, Mr. Barry. Large numbers of Melons were staged.

Collections of vegetables were very good for this dry season. First, Messrs. Hickling, Loughborough; second, Mr. Crawford, Newark. For twelve varieties Potatoes Mr. House, Peterborough, was first with a capital collection. Amongst non-competing exhibits in this tent a collection of twelve fine Pines shown by Mr. Rouse, fruiterer, Leicester; nineteen varieties of Peas and some other vegetables by Mr. Harrison, nurseryman, Leicester; and a very pretty stand of coloured glass and china ornaments by Mr. Fox, Leicester, deserve especial mention.

Roses were shown in far greater numbers than could possibly have been expected at this season, the greater portion being shown by Messrs. Cocker of Aberdeen and Messrs. Harkness, Bedale, Yorks, the Scotch grower beating the celebrated prizetaker of Yorkshire in every instance. For thirty-six blooms—First, Messrs. Cocker, with a nice fresh lot, bright and good; second, Messrs. Harkness, with smaller flowers and brighter; third, H. Merryweather. For twenty-four blooms—First, Messrs. Cocker, with a very bright and even bloom; second, W. J. Grant, Ledbury; third, Messrs. Harkness. Twelve Teas—First, W. J. Grant; second, Messrs. Cocker; third, H. Merryweather. All in this class were small. Twelve blooms, any one variety—First, Messrs. Cocker, with Her Majesty, very fine; second, Messrs. Harkness, with Alfred Colomb; equal thirds, H. Merryweather, also with Alfred Colomb, and Mr. Mack with Pierre Notting. Carnations and Picotees were well shown. For twelve Carnations Ben Simonite was easily first with a capital stand; second, Mr. Jackson, good, but smaller. Twelve Picotees—First, Hans Niemand & Co.; second, Mr. Jackson; third, Ben Simonite. Specimen Picotee—First, Ben Simonite, with Lyddington's Favourite; second, Hans Niemand, with Mrs. Sharp; third, Mr. Jackson. Facing the visitors on entering this tent and extending the whole of one side of the centre table was a group of Orchids, Nepenthes, Sarracenias, and other useful stove and greenhouse plants, containing among other things first-rate varieties of *Catleya Mendeli*, *Dendrobium formosum*, &c. This exhibit was a feature of the Show, and was shown by B. S. Williams, nurseryman, Holloway.

The competition for bouquets, wreaths, &c., was unusually good in every sense of the word. For hand bouquets Messrs. Perkins, Coventry, were first with a very good arrangement of principally white and blush flowers, which were entwined with four spikes of *Epidendrum vitellinum* and a few Maréchal Niel Roses; second, Hans Niemand, Birmingham, with a very nice bouquet, but flatter and too much Fern in it; third, Messrs. Pearson, Chilwell, made of Roses, Tuberoses, Stephanotis, &c. For bridal bouquets the prizes were taken by the same exhibitors, and in the same order. Messrs. Perkins' was large and very good, composed of Roses, Stephanotis, Tuberoses, &c., with a few small leaves of *Caladium argyrites* and Fern; second had again too much Fern, but was very good. For three ladies' sprays—First, Messrs. Perkins, mixed, very light and good; second, Hans Niemand, two of them very good. Buttonhole bouquets—First, Messrs. Perkins, chiefly Orchids, very light; second, Messrs. Pearson; third, Messrs. Carnall, Barkby. Wreaths were grand.—First, Messrs. Perkins, very large, but very light and good; second, Messrs. Pearson; third,

Messrs. Carnall. In the cottagers' tent many first-rate vegetables, &c., were shown.

#### NEWBURY.

THE annual Exhibition of the Newbury Horticultural Society was held on Monday, August 1st, in the picturesque grounds of Shaw House, kindly lent by Mrs. Eyre. The weather being very fine, large numbers of visitors availed themselves of the opportunity afforded them of inspecting the numerous products displayed. Two spacious marquees were set apart for the arrangement of the plants, fruit, and flowers, vegetable exhibitors having to be content with the unfavourable positions assigned to them in the open air, where, as a natural consequence, many exhibits quickly lost their natural freshness.

Stove and greenhouse plants were not very numerous, in some instances the specimens had scarcely attained an exhibition standard. Mr. Mould, Pewsey, was first for six flowering plants, including rather small but well flowered examples of *Statice profusa*, *Ericas*, and *Eucharis*; Mr. Howe, gardener to Sir R. Sutton, Benham Park, Newbury, being second with larger but not such good plants of *Allamanda Hendersoni*, *Rondeletia speciosa*, and *Eucharis amazonica*. Mr. C. Ross, Welford Park, Newbury, was a good first for six foliage plants, and Mr. Howe for twelve exotic Ferns. For a conservatory arrangement, occupying a space 12 feet by 5 feet, Mr. Ross was an easy first, his group gaining many points in lightness over the others, for which Mr. Howe and Mr. Gammon, gardener to J. Bishop, Esq., Newbury, were awarded second and third prizes respectively. In the class for a single specimen foliage plant, Mr. Howe took first honours with a medium sized specimen of *Croton Williamsi*; Mr. C. Ross following with a good plant of *Seafortbia elegans*. Mr. R. Lye, gardener to W. H. Kingsmill, Esq., was the only exhibitor of six *Fuchsias*, for which he was awarded first prize. Mr. Gammon was first for four *Gloxinias*. *Coleuses*, *Balsams*, *Achimenes*, *Petunias*, *Zonal Pelargoniums* were among other plants exhibited in very good quality.

Cut Roses were not staged in quantity, two classes only being provided. For eighteen triplets Messrs. G. Cooling & Sons, Bath, were first with bright and even blooms, Mr. S. P. Budd, Bath, being a close second. Mr. G. Maskell, Donnington, was adjudged first honours for twelve blooms, distinct; Mr. R. C. Norris, gardener to J. Porter, Esq., Kingsclere, taking the second place with larger but too fully expanded blooms. The first prize for twenty-four bunches of miscellaneous cut flowers was awarded to Mr. G. Phippen, Reading, who also held a similar position for a device in cut flowers; this took the form of an anchor of scarlet *Pelargoniums* and white Rose buds on a groundwork of Maidenhair Ferns. The prize for twelve bunches of cut flowers brought three collections, but neither requires any special comment. Mr. Phippen was first for a beautifully arranged bridal bouquet, Mr. Howe coming in first for a hand bouquet. *Zinnias* made a good show, Mr. D. Bosley, Speenhamland, Newbury, taking the lead with large, even-sized flowers, being closely followed by Mr. J. Cook and Mr. C. Norris in the order named. *Asters* and *Dahlias* were well shown, considering the ungenial weather experienced, and the early date of the Show.

Fruit was very well shown, although many of the Grapes staged would have been better later on, Muscats especially being very green. Mr. C. Ross gained first honours for Black Hamburgs; Mr. Maher, Yattendon Court, Newbury, had a similar place for any other black, showing Gros Maroc in splendid condition. Several stands of Muscat of Alexandria were staged, but all were more or less unripe, Mr. C. Howe being first and Mr. C. Ross a good second. Foster's Seedling was shown in the class for any other white by Mr. R. Maher, who secured first place with small but well ripened examples. Two collections of eight dishes of fruit were staged, Mr. C. Howe again coming in for first honours, Mr. Gammon following closely for second position. Messrs. Pope and Lye divided the honours for Peaches, both staging good samples of Barrington, Messrs. Howe and Maher following with Nectarines, Rivers' Orange and Lord Napier being the varieties shown. The best dish of Apricots were staged by Mr. G. Bishop, gardener to the Hon. and Rev. J. H. Nelson. Mr. Norris staged the best Melon, a small but good flavoured fruit of W. Tillery. Apples, Pears, Cherries, and Currants were largely shown, the principal prizewinners being Messrs. W. Pope, C. Ross, R. Lye, C. Howe, G. Maskell, and R. Maher.

Vegetables were staged in capital condition both by amateurs and gardeners. Messrs. Sutton's prizes for a collection of eight sorts of vegetables brought together several baskets of excellent produce. Mr. R. Lye was a good first; his collection included beautiful examples of Canadian Wonder Beans, White Elephant Onions, Intermediate Carrots, Incomparable White Celery, Purley Park Cucumber, Perfection Tomato, &c. Mr. Pope, Highclere Castle, Newbury, was a close second; Mr. Jas. Canning, Donnington, third. Mr. Pope was first for a collection of kidney Potatoes; he also held the same position in the class for rounds, Mr. R. Lye following closely in both instances. Mr. Lye was also successful in the single dish classes for White and Red Celery, Intermediate Carrots, White Elephant Onions, Runner Beans, and Cucumbers. Messrs. C. Ross, W. Pope, Chas. Howe, J. Chamberlain, gardener to F. F. Somerset Esq., showing well in the same classes. Mr. Chas. Ross staged a splendid dish of Tomatoes, for which he was awarded the first prize, Mr. R. Lye being the only remaining exhibitor, both staging Hackwood Park Prolific; the latter also contributed a good basket of salad in variety, for which he gained first honours. The amateurs and cottagers made an extensive display with vegetables, many of the exhibits equalling those of the gardeners, and, in some instances, even surpassing them.

There were some exhibits not for competition. Among them was a box of fine Lord Beaconsfield Raspberries, staged by Mr. Faulknor, of Inkpen, Hungerford. Mr. R. C. Norris being highly commended for a good assortment of named Carnations and Picotees, also some fine Clove Pinks, and a white prettily fringed and delicately scented Carnation named Sandringham White. There were also some very fine *Zinnias* staged by Mr. Eggleton, and a basket of seedling *Coleus* shown by Mr. J. Johnston, Newbury, not for competition.

#### DESCRIPTIONS OF AURICULAS—GREY-EDGED.

(Continued from page 92.)

*Beechton's Fair Flora*.—Once and only once, in the neighbourhood of London, I saw a single pip out of a truss of six of this rich and aristo-

cratic looking flower large enough for exhibition. That once is sufficient to show that it is possible by proper treatment to bring it up to the mark. Pip angular but full, very flat; edge undecided, but of good breadth; colour dark velvety plum, of good proportion; paste good, defined; eye light yellow, anthers not projecting.

*Chapman's Maria*.—A delicate growing plant with a tender constitution, but without a rival the belle of the stage. The pip is rounded, of the shape of True Briton, often very large, not flat; edge pure, of good breadth; colour the most indescribable of ultramarine violet blue, unapproached by any other Auricula, and put on as delicately as it is beautiful in itself; paste unimpeachable; eye pale yellow but tolerably staunch, anthers not too prominent. Not in general a good trusser. This and *Sophia* are said by the raiser to have sprung from Moore's Violet, which is not unlikely.

*Chapman's Sophia*.—Almost as beautiful as *Maria*, but very different, and of a far hardier constitution. The foliage is slightly dusted with meal, serrated, glossy, and handsome. Pip fine and large, sometimes slightly pointed, often quite circular, flat; edge often undecided like Dickson's Duke of Cambridge, which it resembles in more points than one; colour a rich purple undistinguishable from that of Duke of Cambridge or Matilda, rather too broad; paste of proper width, defined, somewhat scalloped; eye bright lemon, open anthers even with the surface. A bold trusser.

*Dickson's Duke of Cambridge*.—This fine flower, the best of Dickson's raising, and only inferior in its sub-class to *Sophia*, should be classed with the greys as that is its characteristic form, but its edge is generally undecided and often green. Petal pointed; pip flattens; colour ruddy plum or purple; paste too narrow and thin; tube orange, and eye of proper size without prominent anthers; good trusser. Foliage narrow, but clean, smooth, and handsome.

*Dickson's Unique*.—A very ornamental variety, but one that would rarely be shewn except in a collection of twelve or twenty-four. Pip too small, pointed, but circular, crumpled; edge undecided; colour deep velvety plum; paste as circular as the uneven surface will allow, hardly broad enough, thin; eye greenish yellow, fades; good trusser; smooth handsome foliage. With many faults, a refined and pretty flower.

*Dixon's Lady Jane Grey*.—One of the inconstants. I have had it a good white edge, and not a bad rich violet plum self with a beaded margin. In its characteristic state it is a good grey that in its early stage is very attractive. Pip not quite flat nor round, inclined to cup; edge pure grey; colour a brownish dark plum; paste circular, not broad enough; eye too large, deep yellow; foliage very peculiar, smooth, glaucous, broad, half-mealed; a fair trusser. Good average flower.

*Finlayson's Sir Robert Peel*.—Large plant; starry, showy flower of no great value. Pip flattens but is pointed; edge decided; colour bright reddish brown, very rich; paste starry but of good substance and well defined; eye orange, but too large, with projecting anthers; bad trusser from shortness of footstalks. Foliage large, abundant, slightly serrated.

*Fletcher's Mary Ann*.—A prude, always very correct, never very striking. Pip round, flat, with a refined but cold repellent look, which is enhanced by the imperturbable purity of the decided edge; colour dark plummy chestnut with no life about it, often hardly broad enough, when it attains sufficient breadth it becomes more irregular and lively; paste broad, even, defined; eye brownish yellow, often too small; foliage very distinct, even, elegant, of light colour, rather narrow with but few leaves. A good trusser, and always a show flower.

*Fletcher's Ne Plus Ultra*.—The reverse of *Mary Ann*. Large, bold, striking, and irregular, but of first-rate usefulness for stage or exhibition. Pip large, flat, circular, broad petalled; edge beaded, of good grey; colour dark velvety chestnut in the boldest dashes; paste without a fault; eye lemon with projecting anthers; foliage small, curled, not serrated; a difficult plant to manage.

*Grimes's Pricateer*.—This oldest of existing named Auriculas, being more than 100 years old, has been accused of want of refinement. I see no such want, though it is not so attractive as many others of inferior properties. Pip fairly circular and flat, with medium-sized petals slightly pointed; edge decided and pure; colour a brown so deep that it may be called black, of sufficient breadth, and well placed; paste circular, of good substance, defined; eye deep yellow with anthers rather too visible. Foliage dark green, mottled, veined, slightly mealed up the rib.

*Headly's Splendour*.—A showy flower that cannot rank high, with light green foliage. Pip well rounded, with large petals, flat; fair grey edge much broken into by streaks and smearing of its too plentiful colour, which is of the amiable reddish violet plum of *Sophia* and all that tribe from Duke of Wellington to Britannia; paste much too narrow, thin; eye greenish orange with high anthers.

*Headly's Stapleford Hero*.—An uncertain flower of the *Mary Ann* sub-class, but which when good will take a high place, though of properties inferior to that variety. Pip pointed, flat; edge good; colour dark chestnut with a dash of plum, starry, bold; paste angular, of good substance; eye brownish yellow, proportionate; fair trusser. Foliage full green, broad, pear-shaped, serrated.

*Headly's Superb*.—Not worth separating from Waterhouse's Conqueror of Europe. A large pip with large rounded petals, flat enough but cupping slightly; decided edge; colour warm chocolate, not broad enough; paste good and round; eye brownish orange with short stamens; a very small rim of red on the edge of the tube like a Roman



Narcissus. Foliage dark green, loose, but more compact than that of Conqueror; serrated.

*Hedge's Britannia*.—A tender plant with robust-looking foliage of light green, and a stout stem which carries well a large even truss almost equal to that of Star of Bethlehem. Pip fat, angular; edge pure grey which soon fades; colour too broad, but of the richest, softest, light reddish plum, the lightest and brightest of all its sub-class; paste of good breadth and form; eye orange, of good proportions, with low anthers. Foliage light green, crisp, neat, slightly indented.

*Lancashire*.—The raiser of this was Robert Lancashire, whose name it most properly bears; but it was let out, after some vicissitudes not very creditable to northern judgment, by Mr. Cheetham, whence its common name Cheetham's Lancashire Hero. With one exception, its undecided edge, it is the model Auricula. Its pip is large, with large rounded petals, and opens flat; edge greenish grey, sometimes nearly a pure green except the bead; colour nearly black, of good breadth, bold; paste well proportioned, defined, of good substance; eye light orange that fades to brown, with very short stamens; magnificent trusser; foliage small, dark glossy green, not unlike that of its evident parent Bolivar, or its grandsire Ringleader. Like all of the race it is slow in opening, but does not cup like the other two.

*Lightbody's Alma*.—A fair second-rate flower, of no great beauty. Pip almost circular but not flat; nor does the truss sit well for want of length in the footstalks; edge good; colour very dark mahogany, not broad enough; paste of good substance and proportion; eye often too large with prominent anthers, of a good orange colour. Foliage pear-shaped, serrated, mealed up the rib.

*Lightbody's Richard Headly*.—Pip well rounded, broad petalled, not large, flat; edge good grey beaded; colour rich brownish plum, not always of sufficient breadth; paste of good substance, circular, defined; eye deep brown orange, anthers even with the surface; medium trusser. Foliage smooth, glaucous, pear-shaped, slightly mealed. Altogether a refined and good flower.

*Lightbody's Sir Charles Napier*.—Of the Conqueror of Europe sub-class, of equal size and of similar foliage. Pip round and flat; edge good grey; colour nearly black but inconstant in breadth; paste well proportioned and circular; eye too broad but of good greenish yellow, good trusser.

*Maclean's Unique*.—A very striking and useful flower, that lasts very long in bloom; but though it looks hardy even to coarseness it is very susceptible of frosts or cold winds in spring which are sure to scorch the edge round the colour. Pip round and flattened; edge good grey; colour of the most likely dark maroon with a dash of plum in it, almost sparkling from its pointed form; paste angular, and might be broader with advantage; eye orange, too large, low anthers; good trusser. Foliage very dark green, smooth.

*Smith's Captain Barclay*.—Pip as large as in Conqueror or Ne Plus Ultra, and as flat as that of the latter, or indeed of any Auricula; rather tame, but not coarse, circular with broad petals; edge a good warm grey; colour purplish violet and enough of it; paste good, round, sufficient; eye orange with very short stamens; foliage curled not serrated; truss —! One of the best of the large flowers.

*Sykes' Complete*.—A fine as well as a striking flower, carrying a large truss often thrown up as in Fletcher's Ne Plus Ultra from a small plant. Pip round but not flat; edge decided grey, beaded; colour well proportioned, of so deep a brown as to be black in daylight; paste even and well proportioned; eye open, of full size, light yellow; tube closed by anthers. From the time the truss appears this variety is easily distinguishable from all others by the dots of meal as large as a pin's head with which every part of truss and stem is covered, whence the beading of the opened pip. Foliage curled and recurved, deep green, glossy, smooth at the edge.

*Warris's Union*.—Not of much value. It most resembles Privateer, but has a lighter body colour, and is not compact either in pip or truss like that variety, but has a straggling look. Pip tolerably flat with deeply indented petals; edge good; colour rich dark brown, even; paste good, round; eye well proportioned, orange; not a good trusser. Foliage abundant, notched, veined, mealed up the rib.

*Waterhouse's Conqueror of Europe*.—An extra sized flower, which therefore presents a difficulty in matching it for exhibition purposes. Pip round, broad petalled, smooth, slightly eupped; edge good grey, too broad; colour dark chestnut, not broad enough, spotted with meal; paste defined, good; eye browned orange with short stamens. Certainly deficient in refinement except when it gives more colour than usual. Sensitive of cold in spring which produces a yellow stripe down the centre of each petal. Foliage spare and uneven, dark green.

*Willmer's Squire Chilman*.—A fine flower. Plant of extra size; foliage large, flabby, abundant, slightly mealed on edge and rib. Pip flat, petals pointed; edge good grey, too narrow; colour rich dark plummy brown; paste good, circular; eye deep yellow, well proportioned, with prominent anthers; truss large and well formed.

*Wood's Lord Lascelles*.—A large, bold, coarse flower, with an undecided edge, though I have once seen it classed as a green, one of a pair than won a silver cup. Those days it is hoped are over. It makes a large plant with handsome serrated foliage, that scuds up a stout stem carrying an ample truss that needs much arranging. The pip is large and flattens sufficiently though not perfectly, pointed; edge light green, thickly spotted with dots of meal; colour very deep brown, bold and good; paste broad, defined; eye light orange, much too large, with projecting anthers.

(To be continued.)

## AMERICAN PLANTS.

THE following notes formed the chief portion of an essay read some time since before the Massachusetts Horticultural Society by Mrs. T. L. Nelson:—

When summer flowers have bloomed and faded, and the Aster and Golden Rod are in their glory—when on the hills the gorgeous tints of autumn are glowing and shimmering in the hazy atmosphere, we begin to think of the time when there will be nothing outside to even remind us of leaf and flower; and then we gather, if we will—for Nature is lavish of her treasures—our winter stores. What visions of the past rise before us, when all outdoors is bound in snow and ice, at the sight of a "winter greenery," as we sit before the fire and our gaze dreamily wanders towards the place where it is sitting. Again we are in the woods enjoying ourselves. At our feet sparkles and dashes the little brook, and, by its side, Moss, Lichen, and Fern are beautiful as ever; we hear the rustle of the leaves over our heads, and it seems so real that it is hard to break the spell.

But all this must be gathered before it can be enjoyed. Meadows, swamps, fields, and woods are to be visited and carefully searched, for in them, oftentimes only indicated by a dried leaf or berry, are the plants, bulbs, and tubers which are resting, and therefore the more to be sought after for winter bloom—for I have found by carefully watching that plants which bloom in spring and early summer are more to be relied upon for flowers in winter than later blooming ones. In cultivated flowers we select the largest and strongest bulbs and roots for winter blooming. If we wish to grow Lilies for winter flowering we select the finest bulbs, for in them is stored the perfect leaf and blossom. So in our selection of native plants select the strongest and best, for some will fail. Surely no florist expects to bloom all the plants and bulbs that he puts in his houses; and for some unexplained reason some—in fact many—refuse to give us flowers in winter, yet they bloom abundantly in their native soil and season. I find from experience that most native plants can be grown successfully in light woody soil with a mixture of meadow moss; and also that flat wire baskets or dishes, not more than 3 inches in depth, lined with moss and filled with earth in which to set the plants, are better than close dishes. After they are filled set them in a dish or saucer with water in it. In this way the moss acts as an absorbent, and supplies water as the plants require it. Moss on the surface, between the plants, is useful in counteracting the dryness of the air in our living rooms—for I take it for granted that native plants are to adorn and beautify our homes; they are not often found in greenhouses. In speaking of the depth of the dishes, I am assuming that only small-growing plants are likely to be cultivated.

And now we will take a look after plants.

First, let us gather *Epigrea repens* (Trailing Arbutus). It ought to be gathered as late as possible, for the buds must be formed before gathered, and then it is not necessary to have much root; only keep the plants moist and close. I have not succeeded often in flowering it, except in a fernery or Wardian case, but it is almost sure to bloom under glass if properly gathered; and how beautiful it is we all know.

*Hepatica triloba* and *H. acutiloba* have thick, persistent leaves, and also form their buds in autumn. I find them among the surest of winter blooming plants; in fact, they bloom in all places—in ferneries or dishes, sun or shade, their pure little blossoms appear almost before we know, or dare expect it.

*Sanguinaria canadensis* (Blood-root) can be easily flowered, and although the foliage is coarse, as the flower comes before the leaf is grown, and as the plants can be forced but once, the foliage is of no consequence. The flower is pure white, and exquisitely beautiful.

*Calla palustris* (Water Arum), our wild Calla, growing in muddy and swampy places, is really an attractive plant, and, having a tuber like *Richardia aethiopica*, can be easily grown, and with similar treatment. In Massachusetts it is herbaceous, and blooms in early summer.

Next we will look after *Arisaema triphyllum* (Jack-in-the-pulpit), which forces finely. You can readily find it by its bunch of intense scarlet berries. On taking away the old stalk, you will find the bud ready to start when you are ready to start it. I have seen exceedingly fine plants of it in winter; and with their stately leaves and blossom they are really very beautiful. They grow equally as well in open dishes or baskets as in a fernery.

*Sarracenia purpurea* (American Pitcher-plant) is easily grown in wet, peaty moss, and, aside from the beauty of its "pitchers" (which you know are really the leaves of the plant), has a very curious flower. It is found in swamps and low, moist ground.

*Erythronium americanum* (Yellow Dog-tooth Violet) bears cultivation well, but will not bear the sun. It is one of the earliest spring flowers and is desirable, as both flower and foliage are beautiful. The foliage varies in marking; sometimes it is very much spotted, and again almost as entirely green.

The lovely *Houstonia cærulea* has never been sung by poets, but nevertheless it is lovely beyond compare. Pure and innocent, it raises its sweet little face to our gaze, and we think of all that is good as we look down upon it. I gathered "Alpine Daisy" on Mount Washington, and admired its lovely blossoms, but, at the time, remarked to a friend, that it was no more beautiful than our little neglected *Houstonia*. This flower is also among the earliest spring flowers. What would be easier, as it grows in clumps, than to take up a piece or clump, and not disturb the roots, and when it has rested let it bloom in winter?

*Clintonia borealis* has a greenish yellow, bell-shaped, Lily-like



flower, which can be cultivated with considerable success, and all must be pleased who do succeed.

The Trilliums are easily grown if you mark the place where they are before the leaves are gone, and take them up after the foliage has ripened. There are at least three species—*T. grandiflorum*, *T. erythrocarpum* (Painted Trillium), and *T. erectum*, and they are all so beautiful it is a wonder more are not bloomed in winter.

Then the Cypripediums. I have three species growing in my garden—*C. parviflorum* (small yellow), *C. pubescens* (large yellow), and *C. spectabile* (pink, or pink and white). I have never flowered them in winter, but they adapt themselves so readily to the garden I take it for granted there can be no difficulty in so doing. I know that *C. spectabile* forms its buds late in the autumn under the old stalk, precisely as *Arisema* buds are found, and that shows conclusively that one can be grown as well as the other.

*Coptis trifolia* (Gold-thread) is very attractive, with its dark green leaves that shine in the sun as if wet with dew. The flower is pure white, and contrasts admirably with the beautiful foliage.

*Mitchella repens* (Partridge Berry) is one of the most charming of all our winter friends, for we get the persistent foliage, and bright scarlet berries; and then it blooms finely in the fernery (and oftentimes out), and we have a combination rarely found, and doubly welcome for its beauty and rarity.

*Pyrola* (Wintergreen) buds in autumn, and blooms well.

Violets are so abundant in variety, that we have only to choose for ourselves; but with them, and in fact all that I have mentioned, we must make a study of their individual habits, and learn how much sun, light, moisture, &c., they require, and give them as fair a chance as the flowers we take from our gardens. I do not believe our native plants are harder to grow, or need more rest and care, than ordinary plants; but do you think we should take as much pains to grow one of our native Cypripediums as we do some of the imported species that are not nearly as beautiful?

I have no doubt that many of our native shrubs are as well worth growing, both for pleasure and profit, as the *Deutzias*, *Spiræas*, and *Azaleas*. *Amelanchier canadensis* (Shad Bush) grows and flowers so freely, there can be no doubt about cultivating it.

*Leucothoë racemosa*, if only for its mythical relation, might be brought into notice. And what more lovely flower in winter than *Rhodora canadensis*, with its rose-purple flowers in umbel-like clusters, blooming before the leaves appear.

*Azalea nudiflora*, our pink or purple wild *Azalea*, grows well in our gardens, and blooms when the plants are small, as does, also, *A. viscosa*, the white variety. Both varieties are growing and blooming finely in two gardens near me, where there is more or less clay, which goes to show that they are not particular as to soil. What, therefore, is to hinder growing them under glass as well as the imported species? I think, however, they should be taken up in the spring and grown through the summer and autumn, in order to obtain good results.

*Rhododendron maximum* adapts itself readily to our gardens, grows as well as the kinds we cultivate in them, and is more hardy. Why not try and grow it for winter bloom?

And so the list might be extended to be quite as long as the list of the cultivated plants that will bloom well in winter. You know, of course, I do not mean stove plants, but only such varieties as are ordinarily grown in winter. Fashion is all-powerful, and if we could make it more fashionable to wear, or to have on our tables, native Violets than the foreign varieties, how the greenhouses and florists' windows would overflow with the modest flowers. Or the beautiful *Azaleas*, *Arbutus*, or *Sanguinaria*, instead of *Marigolds* and *Sunflowers*. As it is, "somebody" starts a fashion and everybody follows it. All the time we look eagerly for "novelties" from any source, at home or abroad, and too often we pay dearly for very little. Why, then, do we not begin at home, and see what can be done with our native plants?



#### KITCHEN GARDEN.

**AUTUMN-SOWN CABBAGES.**—These are favourites in all gardens, and wherever a good supply of vegetables is desired they must be grown. Their importance may not be considered at the present time; but it is by April or May, when they are producing many fine heads, and there is hardly anything else in the garden, that they become so valuable. In summer the Cabbage is a common vegetable, and many might not care to have them then, but in the spring months they are welcomed on all tables. It is because of this that all should be anxious to grow them and have them good. We sometimes hear it said, "My spring Cabbages failed, they were sown too soon or too late," but those who grow Cabbages year after year should learn to avoid failures from such causes. In spring the season differs considerably in certain localities, but just now the weather is much the same everywhere, and there should

not be any great difference in sowing the Cabbage seed. As to the proper time of sowing no one can say to a day, but the whole of the autumn Cabbage seed may be sown within a fortnight, beginning about the 4th of August and ending by August 18th. Those who sow a good variety during the time indicated will not fail to have plants that will bear at a time in spring when they are most valued. Webb's Emperor is a favourite early sort of excellent quality, and there are others of considerable merit. In wet weather or in a wet season we sow the seed broadcast in beds 3 feet wide, but in this unusually dry weather we prefer sowing in drills, as we can open the drills to a depth of 2 inches, water them thoroughly, sow the seed immediately afterwards, and cover at once. The moisture is then retained, the seed germinates quickly and freely, and numbers of young plants are produced in spite of the dry weather. Cabbage plants are often very expensive to buy in the spring, but with a little extra attention many of them may be saved.

**TURNIPS.**—The weather is now as dry with us as it has been any time this season. Our late-sown Turnips do not grow satisfactorily. There are many blanks in the rows, and the young plants appear sickly. We shall not trust to them for our winter supply, and as soon as rain comes a large quantity of seed will be sown. The variety will be Veitch's Red Globe or the American Stone, as it will be a great advantage to deal with a quick-growing variety. If the seed is sown before August is over, or even in September, they will have a good chance of gaining some size before November, and they will grow up to that time at least.

**ENDIVE.**—The earliest of these are ready for planting, but they will not be disturbed until rain comes. They may be late, but they would be later if transplanted now, as it would take them a long time to get over the check they would be sure to receive. Sowing more seed, however, should not be delayed, and if the drills are opened and watered thoroughly before the seed is sown, germination will soon follow.

**PLANTS GOING BLIND.**—No one would think of planting out Broccoli, Savoys, and Brussels Sprouts, unless they possessed a good centre, but many of them lose this after being planted, and if anyone will look over their plantations of winter Greens they will find some of the plants only consist of a few outer leaves. They are "blind," and will never grow or form useful heads. We have known whole quarters affected in this way, and some go in ail gardens. It is an insect that causes it, and we save our plants from it remarkably well by dusting them frequently with soot until they have gained considerable size, and then there is no danger of their failing. The soot plan should be introduced everywhere, and all the plants that have become blind should be drawn up and good ones planted in their places before the season is too far advanced. Do not judge the plants by viewing them from the pathway, as it is only on close inspection that their deficiency can be detected. We have known many remain unnoticed until it was too late to renew them, and blind plants very soon reduce the value of Greens.

**SPINACH.**—We have had none for some time. The dry soil defied us and won. The seed germinated and the plants could be seen in the rows, but they never gained any size, and perished from drought. The want of it has not been felt, as other vegetables have kept the table well supplied, but as Spinach is a favourite vegetable at the table we supply we do not intend being long without it. We are just about to sow some of the prickly variety. A vacant piece of ground recently cleared of Peas will be dug over, the drills will be drawn for the Spinach on it before it dries, and this, with the addition of some water in the drills, will enable the young plants to make a good start, and they will most likely succeed, as the nights will soon become cooler, and this will be in favour of all very young vegetables.

**CABBAGE.**—Peas, Globe Artichokes, and some other vegetables have become scarce in many places owing to the drought, and a continuance of this may cause a scarcity of many things further on. The remains of spring Cabbages may not appear promising at present, but they always furnish a large number of useful sprouts, and until it is seen that autumn vegetables are likely to be plentiful do not throw the old Cabbage away.

**EARLY POTATOES.**—These are now matured. They are rather small, very numerous, and excellent in quality. Should rain come second growth would be common amongst them, but the best way of treating them is to dig them all up at once and store past. They are dry and in prime condition for storing, and the ground from which they are taken will suit other crops, which may be put in as soon as it rains. We have not seen a diseased Potato this season.

#### FRUIT FORCING.

**PEACHES AND NECTARINES.**—*Early Houses.*—The foliage of trees started in December and early January is now beginning to fall; the trees all the same must not lack moisture, affording water or liquid manure to weakly trees as necessary to maintain the soil in a moist but not a saturated condition, as if too much water is given when the trees are to rest and the weather continues hot the excessive moisture at the roots is apt to cause premature growth, which must be guarded against. It does not much matter about rain, as with it the air is correspondingly cool; indeed rain has a most beneficial and invigorating tendency. As a safeguard against starting the bloom buds, allow such laterals as are green and unripe to remain as an outlet for any excess of aliment, they being equally effective in maintaining activity at the roots. Early-forced trees do not as a rule make strong growth, having generally a larger proportion of single fruit buds than trees grown under more

favourable circumstances, triple buds not being nearly so frequent; hence in pruning it is not desirable to cut back next year's bearing wood unless they are of great length. Very little pruning will be needed provided disbudding has been attended to, no more wood being trained in than is required to replace the bearing shoots of the current year and to renew worn out growths, as well as provide for the proper extension of the trees. Trees that have long been subjected to early forcing are seldom vigorous, but not infrequently become so enfeebled as to need the removal of the weak growths, which, though plentifully furnished with fruit buds, are undesirable from their affording much smaller fruit than is yielded by the moderately vigorous and well-ripened growths. Some trees, however, make too vigorous or long-jointed wood, pushing laterals difficult to restrain, if they do not frustrate the formation of fruit buds and interfere with an equal distribution of the sap. Any trees which grow too vigorously must be lifted, whilst those which are showing symptoms of weakness may have the old soil carefully removed from amongst the roots, supplying fresh turfy loam with about a twentieth part of crushed bones and wood ashes mixed. Give a good watering both to the lifted trees and to those that have had the soil renewed about the roots. These operations require to be performed as soon as the leaves are mature and before they fall from the trees.

**Succession Houses.**—Do not neglect to cut away the shoots that have borne fruit unless required for extension, and all the shoots where the growths are too crowded should be thinned. This will allow the foliage to be more readily cleansed by syringing, repeating as necessary, it being important that the foliage be kept clean and healthy as long as possible. With the freer access of light and air the buds will form perfectly, attention being given to a due supply of water to the roots. Where the fruit is ripening a free circulation of air will enhance the quality considerably, sufficient water only being given at the roots to prevent the foliage becoming limp, and secure air moisture by an occasional damping for the benefit of the foliage, also fruit, which in an arid atmosphere is liable to become mealy, whilst it ripens prematurely if the trees suffer for want of a proper supply of moisture in the soil. Ants in some cases are apt to be troublesome, eating into the choicest and best fruits. We sink some saucers in the ground level with their edges, and as near the stems as practicable, pouring syrup or treacle into each saucer. The active creatures leave the fruit for the sweetness.

**Late Houses.**—Attend to thinning and regulating the summer growths, and if they are laid thinner than is customary with trees in earlier houses the wood will have a better chance to ripen and the foliage more certain to assimilate more food; storing it up in the buds and wood for the support of the blossoms and embryo fruit in the coming season. Gross growths tend to the impoverishment of the weaker, appropriate an undue amount of the sap, preventing an equal distribution of the aliment, and favour nothing but unfruitfulness and gumming. They must be stopped, or better removed altogether. Endeavour to secure an even balance of moderately strong short-jointed wood, and to insure its ripening ventilate freely in the early part of the day, allowing a good heat from sun through the day, closing in good time so as to run up to 85° or more, for sun heat after evaporation has been going on for some time will not do any harm if only care be taken to admit a little air before nightfall to allow the pent-up heat and concomitant moisture to escape, and the gradual cooling down of the atmosphere, thereby securing rest. The night and early day ventilation tends to the solidification of the growth and its ripening. Keep the trees free from red spider by forcible syringings until the fruit gives indications of ripening. The borders must be well supplied with water or liquid manure, and be well mulched with short manure.

**VINES.**—**Early Houses.**—The Vines have the wood ripe, and the foliage or some of it is falling, but there must not be any attempt at removing it, nor to cut the laterals close in, as that would probably cause the principal buds to start; therefore remove the laterals by degrees, and shorten some of the long shoots, preserving, however, some growth, especially when the principal leaves are down, above the buds to which the Vines are to be pruned, the final pruning being deferred until the early part of next month. The old surface soil should be removed and forked from amongst the roots, taking the opportunity of raising any that are deep and laying them in fresh material nearer the surface. Good calcareous loam is the most suitable, with a twentieth of crushed bones and wood ashes. If the soil be light add a six of clayey marl, if heavy a sixth of old mortar rubbish. Charcoal is an excellent addition to the extent of a tenth. Give a moderate watering, and the roots will push (especially adventitious ones from near the collar) into the new soil at once, and be in capital condition for a start when the time comes round. When lifting or renovating the border is deferred until the leaves are all down the start is not nearly so satisfactory.

**Mid-season Houses.**—The Vines have done well considering the prolonged drought, revelling in the light and heat, and red spider has not been nearly so troublesome as might have been expected. The Grapes have acquired bloom and colour rapidly, and though not quite so large in berry it is amply compensated for by the superb finish. Copious supplies of water through a good surface mulching, and occasional supplies of liquid of a sustaining rather than stimulating kind, have contributed to the satisfactory result. Madresfield Court is taking its place—the foremost of midseason Grapes. Fire heat has not been necessary, as the requisite ventilation by night as well as by day could be secured to insure a circulation of air. The nights being rather cold have assisted Vines carrying heavy crops to perfect them through the rest accorded.

**Late Houses.**—Continue to afford full supplies of heat through a good surface mulching, and until the Grapes are well advanced in colour, for most late Grapes take a long time to perfect thoroughly; and some, particularly Mrs. Pince, even after appearing finished, are not so up to the shank, which is often a consequence of too early stopping the supplies of food, and in some cases the consequence of too short duration of the feeding are manifest in the Grapes shrinking. All late Grapes require time; they ought now to be colouring or advanced therein, and then they will with a circulation of warm rather dry air constantly attain a fulness of berry and a perfection of finish; indeed, poverty of finish is the chief cause of shrivelled Muscats, and others shrinking after they have hung some time. Afford a temperature of 70° to 75° by day artificially, 80° to 90° with sun, and close sufficiently early to increase to 90° or 95°. When the sun is losing power put on enough top and bottom air to insure a circulation of air, allow the temperature to gradually cool, which rests the Vines, and increase the ventilation early with the advancing temperature. The pipes should, if necessary, have a little warmth in them to prevent the night temperature falling below 65° at night.

#### PLANT HOUSES.

**Adiantum cuneatum.**—Where these are grown expressly for cutting they must not be in a close atmosphere, or they will wither directly they have been severed from the plants or exposed to more air conditions. A deep green colour of the fronds indicates too much shade and heat, and will not last. The young fronds on plants well prepared should have a reddish hue, and those fully developed a light green appearance. This is the result of light airy treatment. Plants that have been grown soft may be prepared to stand well if they are carefully and gradually exposed to light and more air, but they are never so good as those grown under these conditions from the first. The development of the fronds is slower and the plants are longer before they attain a large size, but the main object is attained, and the fronds are fit for use directly they are well developed. In the end it is economy to prepare the plants well for this purpose, for less than half will give greater satisfaction and less trouble than double the number grown under close treatment. Young plants raised from spores in spring and now in 3-inch pots may be placed into 5-inch pots, in which they will develop a good number of fronds before winter, and make large plants another year.

**Adiantum Pacotti.**—This useful variety is well worth growing for cutting, in addition to *A. cuneatum*; although it is too heavy for many purposes, it is invaluable for buttonholes. In spite of this, however, it will never supplant the old variety alluded to, for it will not yield the same quantity of fronds. The fronds are stiff, and need no wiring. To do it well it should be grown slightly warmer than *A. cuneatum*, and every care must be taken that water does not fall upon the fronds, for they are so thick that they are liable to damp. During hot weather, when plenty of air can be given, the fronds dry quickly, and less harm is done.

**Davallias.**—For many purposes the fronds of these Ferns are valuable, because they last fresh for a long time. For cutting to travel long distances and last well after they reach their journey's end, no other Ferns are equal to them. These, like *Adiantums*, should not be grown too warm. The majority of kinds suitable for this purpose will do well in the greenhouse during the summer months, but require a temperature of 50° during the winter. *D. bullata*, *D. dissecta*, and some others are not injured in the least by remaining in a cool house the whole of the winter. Although many do well in the greenhouse they will make more rapid progress under intermediate conditions until the plants attain a fair size, or for starting them into growth in spring.

**Pteris serrulata.**—This is a handsome and useful Fern for decoration in small pots, and lasts well in rooms and other positions during the winter. A good number of seedlings now in pans and boxes should be placed singly into 2 and 3-inch pots according to the size most suitable. For grouping purposes we find them serviceable in various sizes from 2 to 5-inch pots; for the latter size two or three seedlings grown together are better than single plants, because they are thicker and better furnished at the base. This will grow in almost any soil and position, provided it is liberally supplied with water. We have usually started them in gentle heat, and when sufficiently developed removed them to cool quarters.



#### NOTES ON BEES.

##### CROWDING BEES DURING WINTER.

THERE are many bee-keepers who act like the small bee-keeper mentioned by "R. C., Kent," and many things in bee-keeping are recommended to be done that are positively injurious to bees, hindering them in their labours and lessening the profit of the bee-keeper. Removing frames of comb on the approach of winter or

during autumn is one of these. A swarm that has built its combs and filled its hive with them ought not to be interfered with further than removing surplus honey or feeding up to the required weight if necessary. There is no advantage whatever gained by removing combs during the fall, but, on the contrary, much harm is done, not speaking of the bother attending the storing of combs and the trouble of removing them from the hive, the safest and best place for them when the hive is prepared for winter as it should be. Bees in a crowded hive during winter are more often on the wing than they should be, or than others differently treated are, hence they decrease in numbers. Giving bees plenty of space during winter is the best means of preventing too early breeding and other evils.

If hives are to be contracted at all the month of March is the best time to do it; then as early as possible before the bees are crowded put back the combs removed, but when the two systems are thoroughly tested no advantage will be found to accrue from those operated upon. With me this year, nuclei in large hives during winter have given large yields, but, again, these may be so small that it is advisable to contract a little, but never to crowd them.

#### "THE BEST HIVE IN CREATION."

In its complete form this is more expensive than the cheap hive I described, protected by an outside case or roof of iron, which is but a modified form of the "best hive in creation," and well adapted for every locality and system of bee-keeping, producing finer and more comb than other forms of hives.

#### THE STANDARD HIVE.

The standard hive advanced by interested persons is not a hive in its original state that will give satisfaction or profit. Since my articles appeared on cheap hives many have been made by bee-keepers, and I have had orders for some hundreds of them, but had to decline all, except a few that I supplied from my own stock, intended for my own use, and in every instance those who had them, practical bee-keepers, gave them an excellent character. The latest one was to the effect, "It is the hive; the only ones I removed my bees in to the Clover during the warm weather, a distance of fifty miles, that were uninjured."

I know what is wanted in a hive as well as what is superfluous, and to those who take their bees from one place to another these hives are a pleasure rather than a toil, as is the case with most other hives. The reason that they are not advertised arises from different causes, but I believe I am right in saying the principal one to be, that the "Standard hive" is believed by novices to be perfect. Being fully cognisant of these things and of the opinions and experience of those who had much to say on bee-keeping was my reason for laying before your readers a full account of the cheap hive, its construction and how to make it. Where the amateur has a circular saw the work will be quite easy. The rogle, or trenching plane, is a useful tool, and dispenses with the circular saw in many cases. To prepare the front and back portion of the hive as well as those of supers, cut to the exact length, fix laths upon a board the thickness to be left beneath that checked out, then nail another piece upon the top as a stopper, place the wood in the recess, which must be of the neat size, outside measure. Now make a template, neat inside measure, having a fence held firm down, and shoot the plane round the ends and edge, and the work is done; the sides only require to be cut an exact length, about one-sixteenth longer than the top bars, and

nail, which is better for hive work than dovetailing. If "R. C., Kent," follows these directions he will have hives that will suit him well whatever are his circumstances. During this summer I have witnessed many hives sent to novices that it is impossible for bees to exist in during winter, whether it be severe or mild.

#### FOREIGN BEES.

These are doubtless an acquisition, but their habits require to be studied. I place the Carniolians first on the list, owing to their hardiness, amiable temper, and good honey-gathering qualities; they are as prolific as any, and the excising of queen cells on the eighth day after the prime swarm leaves will prevent trouble with after swarms. This can be done easily with these bees without either veil or quieter. They build comb more rapidly than most varieties, and store much honey, but do not seal it so soon as Syrians. The latter seal as they store, and very often supers will be found not filled with comb, but all that contains honey sealed. I have had the Carniolians nine years now, and they have always given satisfaction. The crossed Cyprians have surpassed them in making more weight; but when we find bees filling two body boxes and three supers of 20 lbs. each, one body box next the supers weighing upwards of 30 lbs., all in five weeks from the time it occupied but one box, and all the others of the same breed as satisfactory, it is safe and pleasant to recommend such industrious bees.

#### SYRIAN BEES.

I took some of these bees to the moors on the 20th of July, and must confess I never saw bees work more eagerly than they did that day; and although it was a carpet of flowers, Wild Thyme in profusion within a few yards of them, the shepherd informed me he saw them working upon the Bell Heather between two and three miles distant from their stand. The distance bees fly and work profitably is still an unsolved question. I was somewhat amused with the persistence of these bees when set down and released to attempt to find their hive behind but between two others as it stood when at home. While this was interesting, it was all the more so to see the bees fly right over their hives and attempt to find the entrance facing the same direction as it was at home. It was the first time I observed this, but it explains fully that bees have a knowledge of the points of the compass unaided by any mark. Their instinct, great in that as it is in locality, shows plainly how they can return unerringly to any spot they have a desire to.

My hives at the moors are wrapt in a piece of old sacking or mat, with the semi-circular iron roof, are alike protected from sun or rain, await the first opportunity of fine weather to fill their hives to overflowing in ten days or so from the finest bloom of Heather I have ever witnessed, and two weeks earlier than the average of years. Should a week's fine weather occur, I shall lose no time in putting on an extra cover of supers, as, if not done, crowding out will be the result; but I will not allow it, as crowding bees in any manner has never been found profitable by—A LANARKSHIRE BEE-KEEPER.

#### BEES GATHERING HONEY OFF WHEAT.

Is it not unusual for bees to gather honey from Wheat? I was in a Wheat field a few days ago adjoining my garden and only a few yards from my hives, and found hundreds of bees busy on the ears of Wheat. On examination I found fluid—honey I suppose—issuing from where the sparrows had taken the corn.

I have not had a single swarm from six stocks of bees this season, three in bar-frame hives and three in skeps. This I attribute to the late cold spring. The result has been nearly the same with other bee-keepers, scores of stocks in skeps have not swarmed.—J. HARRIS.



## TRADE CATALOGUES RECEIVED.

Louis de Smet, Ghent, Belgium.—*Lists of Orchids and General Plants*.  
 Auguste Van Geert, Ghent, Belgium.—*Catalogue of Azaleas, Rhododendrons, Camellias, Palms, and Orchids*.  
 Waite, Nash & Co., 79, Southwark Street, London, S.E.—*Wholesale Catalogue of Flower Roots, 1887*.



All correspondence should be directed either to "THE EDITOR" or to "THE PUBLISHER." Letters addressed to Dr. Hogg or members of the staff often remain unopened unavoidably. We request that no one will write privately to any of our correspondents, as doing so subjects them to unjustifiable trouble and expense.

Correspondents should not mix up on the same sheet questions relating to Gardening and those on Bee subjects, and should never send more than two or three questions at once. All articles intended for insertion should be written on one side of the paper only. We cannot reply to questions through the post, and we do not undertake to return rejected communications.

**LATE INQUIRIES.**—It is necessary to again remind correspondents that letters arriving on WEDNESDAY MORNING cannot be answered in the "next issue," which is then far advanced for press.

**A Seedling Fern (R. H. S.).**—Your Fern is apparently a variety of *Adiantum cuneatum* with compact fronds like *Adiantum Pacotti*, but larger. The latter has become a favourite for decorative purposes, and if your seedling was well grown it would no doubt be similarly useful. It is not uncommon to obtain such varieties when spores are sown of cultivated Ferns. Many curious forms of British Ferns have been selected in this way.

**Balsams (W. J. G.).**—The flowers are of fine substance, good size, and excellent form, but the beauty of the plants would depend chiefly upon the number of flowers they had.

**Longleat Perfection Melon (Bradwen).**—This excellent Melon is the result of crossing the old Cashmere with Eastnor Castle, these two Melons having for several years been exclusively grown at Longleat.

**Tomatoes (F. W.).**—Your plants appear to be attacked with a fungus, analogous to that which attacks Potatoes. We are not aware of any remedy, but you cannot err by dusting the plants with sulphur, and maintaining a dry rather than a moist atmosphere, taking care to provide a free circulation of air night and dry.

**Tomatoes (A. B.).**—We are not able to say which of the two varieties you name is the most reliable cropper, as we have seen equally fine crops of both. Hackwood Park crops very heavily, but does not always set the first trusses well. Plants from cuttings usually fruit the best in the winter, but sturdy well prepared seedlings often answer very well. As to the boilers if of equal size we should choose the one that cost the least to purchase. The power of both would be increased with watering bars, and these we should have.

**Cycas Fruits (X.).**—A kind of Sago is produced from the pith of *Cycas revoluta* in Japan, and the nuts are edible. *C. circinalis* also yields Sago, and the fruits, which are of the size of an Orleans Plum, are eaten in the Moluccas after being fermented and roasted. We must decline the responsibility of advising you on the question of exhibiting your fruit in a collection for dessert purposes, as there is no telling whether the judges would disqualify or not, as, so far as we know, they have no precedent to guide them in the matter.

**Wet Vine Borders (Subscriber).**—By all means make provision for the escape of water according to the method suggested in your letter, taking care not to injure the roots of the Vines any more than can be helped during the operation. We think you only complained of one Vine before, and this at least we should imagine you could replant, affording adequate drainage and better soil. The others would probably improve with the improved drainage and a dressing of fresh soil mulched with manure for inciting surface roots.

**Caterpillar on Lime (R. C. M.).**—The caterpillar is that of the Lime Hawk moth (*Smeristhus Tiliæ*) about half grown. It is not a common insect, but occurs in many localities, some near the metropolis. It is distinguished from its brethren in the family by a curious horny plate above the tail. The food is also Elm as well as Lime, and after the winter has been passed in the pupal condition the moth emerges about the beginning of June, and flies vigorously at dusk.

**Dwarf Chrysanthemums (S. Wilks).**—Sturdy, healthy cuttings grown in the full sun, inserted now in small pots of sandy soil, stood on damp ashes in a frame, kept moist, close, and shaded to prevent the leaves flagging, strike readily, and the plants are often very serviceable for various decorative purposes. The cuttings and young plants cannot have too much light and air consistently with keeping the foliage fresh. Thousands of dwarf plants of Pompon varieties are raised from cuttings inserted in July and August.

**Chrysanthemums Eaten (Wordsworth).**—The larger tops sent have been eaten by earwigs, the smaller punctured with the very small brownish weevil-like insect we find in the box. It is very destructive. Syringe the plants, and when wet dust with tobacco powder, not only the tips, but a few inches down the stem. It punctures the soft part, destroying the tissue, and the shoots curl over. We had recently the mortification of catching the enemy at work on some splendid plants in a garden near Liverpool. The specimens you have sent shall be examined by an entomologist; in the meantime apply tobacco powder promptly and repeatedly, as may be required, and we think you will prove the conqueror.

**Sowing Nigella (Love-in-a-Mist) in Autumn (E. T. H.).**—Unless the situation and soil be favourable and the winter prove mild it is undesirable to sow this curious plant in autumn for spring flowering. It is best sown in early April, and it then flowers most of the summer. The best kinds are *N. damascena* and *N. hispanica*.

**Early Paris Market Lettuce (Idem).**—Its chief recommendation is its earliness, it being particularly valuable for sowing on warm borders in early spring for a supply of heads in early summer. It is also good for successional sowing through the summer, being very tender and exceedingly crisp, also for sowing in August and planting in frames to stand the winter to give a spring supply. It makes quite as good a heart as All the Year Round, but neither is so good for standing as Veitch's Perfect Gem, which has been our sheet anchor this droughty season.

**Apple Tree Leaves Spotted (J. C.).**—The leaves sent are attacked by the Pear-tree blister moth (*Tinea Clerckella*), which deposits its eggs in May or June upon the foliage; and the larvæ, immediately they are hatched, penetrates beneath the cuticle, and by feeding upon the parenchyma cause numerous brown spots or blisters. The best remedy is to collect the leaves in autumn and burn them, so that the chrysalis may be destroyed. In early June wash the trees with soapsuds, repeating a few times at a few days' interval through that month, employing a syringe or garden engine for the distribution of the liquid.

**Small Worms in Soil (J. R. S. C.).**—We are obliged by your letter. We have no doubt the minute worms like threadworms are the destructive agents in the case. The soil appears infested with them, and for that used in pottng the remedy is simple—namely, scorching. If placed in the ashpits under the fires in stokeholes or in other more convenient places it can be heated till all animal life is destroyed. The soil has only to be moistened to be made fit for using, and it will be more fertile than before the scorching. Where rubbish is burned in heaps in fields the aftergrowth is invariably more luxuriant where the fires have been than where the soil has not been scorched. It is conceivable the pests may be conveyed to the soil in the water that is used, but we do not think such is the case in the garden referred to.

**Chemical Composition of Plants—Urine (J. H. E.).**—We know of no work or works that give the information you appear to require. We do not know that quantitative analyses of Rose seed and Heath seed have been determined. We are unable to indicate with precision the particular soil or strata on which Yarrow refuses to grow, but little of it is seen in wet feu land, which is composed largely of decayed vegetable matter. Urine should not be used quite fresh, nor on the other hand should putrefaction be permitted to continue very long, or much of the carbonate of ammonia that is produced by fermentation will escape. Perhaps the best time to use the liquid is when it is three or four days old, or when fermentation is apparent. About six volumes of water will render it safe for the majority of crops.

**Grapes Shank (A. B. C.).**—As the Vines have only been planted two years we should lift them after the crop is cut, and place the roots nearer the surface in good loam with wood ashes and crushed bones mixed therewith, draining the border well and surfacing with manure. Placing strong fresh manure in contact with the roots and making it like a puddle, as you appear to have done with syringing, would cause the roots to decay and the Grapes to shank. As your house is only small you could easily sponge the under surfaces of the leaves with a mixture of softsoap and sulphur. Beat some sulphur into a paste, then mix it with the solution, which may be made by dissolving 2 ozs. of softsoap in a gallon of water. This applied to the leaves as suggested and left there for three days will destroy the red spider. The mixture should be of the consistence of cream when used.

**Varieties of Black Hamburgh Grape (W. A.).**—The best variety of Black Hamburgh is undoubtedly Mill Hill, which has the fine appearance of Dutch Hamburgh, but without the coarseness and hollowness at the centre that characterise that form, and the quality is equal to that of the Black Hamburgh; the latter is, however, excellent, and as a rule grows better than the Mill Hill. By planting the Vines now you will take time by the forelock—i.e., get them established, and they will be in a condition to make a good start when the house is closed in February. It is only a question of shading until the Vines recover from the partial disentangling and spreading out of the roots in the fresh material, afterwards exposing the growth fully to light so as to get the wood ripe. Cut hard back, and they will start well with the other Vines. It would be preferable to plant at once than defer it until the house is started in February.

**Superphosphate of Lime (T. Jackson).**—It is more useful as a manure than bones, because it is more soluble in water. If we bury a bone it will remain almost unaltered for years; but if we break it into small pieces it decays much sooner, and if put round the roots of Cabbages will soon make them grow more fine and vigorously. Cabbages, however, are not the only garden vegetables benefited by bone manure, for phosphate of lime is one of the most constant constituents of all plants. Of this phosphate, therefore, the soil is deprived by every crop it bears, and to restore this phosphate to the soil is an object with every cultivator. It was long since shown by chemists that phosphate of lime is the chief ingredient in all bones, and consequently these by degrees have become one of the most extensively used manures. In every 100 lbs. of sheep's bones there are 70 lbs. of phosphate of lime; in 100 lbs. of horses' bones sixty-eight of that phosphate; and in the same quantity of ox bones 55 lbs. As phosphate of lime is insoluble in water, and even bone dust is slow in decaying, it was suggested that by dissolving it in a strong acid, superphosphate of lime, a substance soluble in water would be formed, and also all the other con-

stituents of the bone be presented to the roots of the crop in a most available form. This process is said to have been first adopted by Mr. Fleming of Borrochan, N.B., in the year 1841. He employed muriatic acid (spirit of salt) to dissolve the bones, but it was subsequently found that sulphuric acid (oil of vitriol) was both cheaper and better.

**Marechal Niel Roses (G. S.).**—We are most willing to give what information we can, and we desire that when anything stated by us is not understood that further inquiries should be made for elucidation. It was stated in our reply last week that if a wall existed it would be economical to erect a house against it, and that with a front 2½ feet high and a width of 18 feet the wall should be 15 feet high. That would give the proper pitch and slope of roof for the Roses, the growths being trained to wires about a foot from it. When we said the back wall would not be of much use we, of course, referred to it for covering; and it is very certain if the roof were well covered, as it should be, without overcrowding, the back wall, then shaded, would be of small use for Roses. We gave you a reference to the Rose houses at Ascot, also dimensions for a span-roofed structure. We will now reproduce what appeared in our columns not very long ago about growing the Maréchal in a lean-to at Burghley:—"In one house Figs cover the back wall, with Maréchal Niel Rose on the roof in grand condition. We have seen many remarkable examples of this fine Rose, one of them bearing 3000 blooms, but the Burghley specimen surpasses them all as a type of high culture. It is on the Briar, and fortunately worked low, as ought always to be the case when this Rose is worked at all. It is planted in the centre of the house and close to the front, horizontal main branches being trained right and left along the base of the rafters. These horizontal mains are the only permanent portions of this fine tree. At intervals of 5 or 6 feet wires are stretched up the roof, and to these are secured the flowering shoots; and it is to be particularly noted they are annual shoots—that is to say, as soon as the blooms are cut in May or June the growths are cut quite down to the base of the rafters. The roots being in rich soil and generously fed strong growths start at once, and four or five of these are trained up each wire. They speedily reach the top, and are then shortened. These young growths are fully as thick as an ordinary pencil, and many of them much thicker, while the foliage is remarkable for its size, substance, and deep rich green. One of the leaflets casually measured exceeded 6 inches by 5, exclusive of the footstalk. When it is remembered that every bud on wood thus prepared affords at least one flower some idea may be formed of the pendent massive lines of golden blooms that must be produced. The effect cannot but be magnificent and worth a long journey to see. This is the simplest and best of all systems of growing the Maréchal Niel Rose under glass. We have proved its value years ago, and seen the plan carried out by others, but never so well as in the example under notice. The wires are placed at the distance stated, so that the Figs on the back wall received the light between the cordous of Roses. The stock of the Maréchal, as is almost invariably the case, has increased much faster than the Briar. This is the cause of the death of many fine plants, or rather trees when budded high, but worked low the junction can be covered with soil. This is what has been done at Burghley by packing a wall of turves round the stem after a sharp knife had been drawn down the Briar portion, cutting quite through the bark, and it is expected the health and vigour of the specimen will be maintained. The roof under which this Rose is trained is 30 feet long by 18 or 20 deep. Worthy of record as are many doings at Burghley, not one is more worthy than this splendid instance of Rose culture." You will perceive that much space was allowed between the Roses for admitting light to the Figs on the back wall; but for them the Rose growths might have been trained a foot apart up the roof, and then the back wall would be shaded. Roses might be grown against it, no doubt, but they would be few and poor in comparison with those on the roof. It would not be advisable for you to rely on one plant. Do what we advised, and cut the Roses well back to induce strong growth the first season; when these reach the apex of the roof top them, and if the wood is strong and ripe it will yield fine blooms the entire length, and if these are cut early—say in May—the old stems, if cut down to the base of the rafters, will push strong growths that will quickly cover the roof again for flowering another year—always provided that the best cultural attention is given, the Roses being adequately supported, and not an insect of any kind allowed in the house. We think with the aid of our two replies you ought to be able to succeed in your object; still, if there should be anything you yet fail to comprehend do not hesitate to write again.

**Names of Plants.**—We only undertake to name species of plants, not varieties that have originated from seed and termed florists' flowers. Flowering specimens are necessary of flowering plants, and Fern fronds should bear spores. Specimens should arrive in a fresh state in firm boxes. Slightly damp moss or soft green leaves form the best packing, dry cotton wool the worst. Not more than six specimens can be named at once. (F. W.)—1, Begonia Ingrami. 2, B. metallica, both of very easy culture, requiring a warm greenhouse or cool stove temperature in the winter. The numbers should always be written on the outside, not inside the paper ligatures of plants sent to be named. (Reader).—Pyrus Aria, the White Beam Tree. (W. H., Blackheath).—1, Aserides crassifolium. 2, Dendrobium secundum. (J. C., Bristol).—We should be pleased to oblige you with the names of any specimens, but the flowers suffered so much in transit through the post in such a fragile box that we can only suggest that the Cymbidium is pendulum; the Aserides, odoratum and Larpentæ. (C. S.).—2, Asplenium longissimum. 4, Adiantum formosum. The others were insufficient. (W. R.).—1, Harpalium rigidum. Yes, it is much like Helianthus japonicus as seen from some of the nurserymen. 2, Lilium chalcædonicum. 3, Scabiosa caucasica. (D. C.).—Melilotis officinalis.

**Bees in Roof (T. L.).**—The only way we know of getting rid of the bees is by fumigation, but the place they have occupied seems by your account to be so difficult of access. We are sorry we cannot suggest any other way.

**Bees (O.).**—Your suggestion has been frequently considered, and would have been carried out but for the certainty that it would be a failure financially.

COVENT GARDEN MARKET.—AUGUST 10TH.

OUR market is now getting quieter, soft fruit being nearly done. Prices remain as last week.

FRUIT.

	s. d.	s. d.	s. d.	s. d.
Apples, ½ sieve .. ..	0 0	to	0 0	
Nova Scotia and Canada barrel	0 0		0 0	
Cherries, ½ sieve .. ..	5 0		8 0	
Cobs, 100 lbs. .. ..	0 0		0 0	
Figs, dozen .. ..	1 6		2 0	
Grapes, per lb. .. ..	1 6		2 6	
Lemons, case .. ..	10 0		15 0	
Melon, each .. ..	2 0		3 0	
Oranges, per 100 .. ..	6 0	to	12 0	
Peaches, dozen .. ..	2 0		6 0	
Pears, dozen .. ..	1 0		1 6	
Pino Apples, English, per lb. .. ..	1 6		0 0	
Plums, ½ sieve .. ..	0 0		0 0	
St. Michael Pines, each	3 0		5 0	
Strawberries, per lb. ..	0 0		0 0	

VEGETABLES.

	s. d.	s. d.	s. d.	s. d.
Artichokes, dozen .. ..	1 0	to	2 0	
Asparagus, bundle .. ..	0 0		0 0	
Beaus, Kidney, per lb. ..	1 3		0 0	
Beet, Red, dozen .. ..	1 0		2 0	
Broccoli, bundle .. ..	0 0		0 0	
Brussels Sprouts, ½ sieve	0 0		0 0	
Cabbage, dozen .. ..	1 6		0 0	
Capsicum, per 100 .. ..	1 6		2 0	
Carrots, bunch .. ..	0 4		0 0	
Cauliflowers, dozen .. ..	3 0		4 0	
Celery, bundle .. ..	1 6		2 0	
Coleworts, doz. bunches	2 0		4 0	
Cucumbers, each .. ..	0 4		0 6	
Endive, dozen .. ..	1 0		2 0	
Herbs, bunch .. ..	0 2		0 0	
Leeks, bunch .. ..	0 3		0 4	
Lettuce, dozen .. ..	0 9	to	0 0	
Mushrooms, punnet .. ..	0 6		1 0	
Mustard and Cress, punt.	0 2		0 6	
Onions, bunch .. ..	0 3		0 6	
Parsley, dozen bunches	2 0		3 0	
Parsnips, dozen .. ..	1 0		0 0	
Potatoes, per cwt. .. ..	4 0		5 0	
" Kidney, per cwt. .. ..	4 0		0 0	
Rhubarb, bundle .. ..	0 2		0 0	
Salsify, bundle .. ..	1 0		1 6	
Scorzoner, bundle .. ..	1 6		0 0	
Scakale, basket .. ..	0 0		0 0	
Sballots, per lb. .. ..	0 3		0 0	
Spinach, busbel .. ..	8 0		4 0	
Tomatoes, per lb. .. ..	0 4		0 6	
Turnips, bunch .. ..	0 4		0 6	

PLANTS IN POTS.

	s. d.	s. d.	s. d.	s. d.
Aralia Sieboldi, dozen ..	6 0	to	12 0	
Arbor vitæ (golden) dozen	6 0		9 0	
" (common), dozen .. ..	0 0		0 0	
Azalea, dozen .. ..	0 0		0 0	
Begonias, dozen .. ..	4 0		9 0	
Calceolaria, dozen .. ..	3 6		8 0	
Cineraria, dozen .. ..	0 0		0 0	
Creeping Jenny, dozen ..	3 0		4 0	
Dracena terminalis, doz.	30 0		60 0	
" viridis, dozen .. ..	12 0		24 0	
Erica, various, dozen .. ..	0 0		0 0	
Euonymus, in var., dozen	6 0		18 0	
Evergreens, in var., dozen	6 0		24 0	
Ferns, in variety, dozen	4 0		18 0	
Ficus elastica, each .. ..	1 6		7 0	
Foliage Plants, var., each	2 0		10 0	
Fuchsia, dozen .. ..	3 0	to	9 0	
Geranium (Ivy), dozen ..	3 0		6 0	
" Tricolor, dozen .. ..	3 0		6 0	
Hydrangea, dozen .. ..	9 0		12 0	
Lilies Valley, dozen .. ..	0 0		0 0	
Lilium lancifolium, doz.	12 0		18 0	
" longiflorum, doz.	18 0		24 0	
Lobelia, dozen .. ..	3 0		5 0	
Marguerite Daisy, dozen	6 0		12 0	
Mignonette, dozen .. ..	3 0		6 0	
Musk, dozen .. ..	2 0		4 0	
Myrtles, dozen .. ..	6 0		12 0	
Palms, in var., each .. ..	2 6		21 0	
Pelargoniums, dozen .. ..	6 0		12 0	
" scarlet, doz. .. ..	3 0		9 0	
Spiræa, dozen .. ..	0 0		0 0	

CUT FLOWERS.

	s. d.	s. d.	s. d.	s. d.
Abutilons, 12 bunches ..	2 0	to	4 0	
Anemones, 12 bunches ..	0 0		0 0	
Arm Lilies, 12 blooms ..	3 0		6 0	
Asters, 12 bunches .. ..	8 0		6 0	
" French, bunch .. ..	1 6		2 0	
Azalea, 12 sprays .. ..	0 0		0 0	
Bluebells, 12 bunches ..	0 0		0 0	
Bouvardias, bunch .. ..	0 6		1 0	
Camellias, blooms .. ..	0 0		0 0	
Carnations, 12 blooms ..	1 0		2 0	
" 12 bunches .. ..	4 0		6 0	
Cornflower, 12 bunches ..	1 6		3 0	
Dahlia, 12 bunches .. ..	3 0		6 0	
Daisies, 12 bunches .. ..	2 0		4 0	
Encbaris, dozen .. ..	4 0		6 0	
Gardenias, 12 blooms ..	1 6		3 0	
Hyacinths, Roman, 12 sprays	0 0		0 0	
Iris, 12 bunches .. ..	0 0		0 0	
Lapageria, white, 12 blooms	0 0		0 0	
Lilium longiflorum, 12 blooms	3 0		6 0	
Lilium lancifolium, 12 blooms	1 0		2 6	
Lilac (white), French, bunch	0 0		0 0	
Lilies, White, 12 bunches	0 0		0 0	
" Orange, 12 bunches	0 0		0 0	
Lily of Valley, 12 sprays	0 0	to	0 0	
" 12 bunches .. ..	0 0		0 0	
Marguerites, 12 bunches	2 0		6 0	
Mignonette, 12 bunches	1 0		3 0	
Myosotis, 12 bunches ..	2 0		3 0	
Narciss, 12 bunches .. ..	0 0		0 0	
" White, English, heb.	0 0		0 0	
Pansies, 12 bunches .. ..	0 0		0 0	
Peas, Sweet, 12 bunches ..	3 0		6 0	
Pelargoniums, 12 trusses	0 9		1 0	
" scarlet, 12 trusses	0 4		0 6	
Pinks, White, 12 bunches	0 0		0 0	
" various, 12 bunch	2 0		4 0	
Porony, 12 bunches .. ..	0 0		0 0	
Poinsettia, 12 blooms ..	0 0		0 0	
Primula (single), bunch ..	0 0		0 0	
" (double), bunch .. ..	0 9		1 0	
Polyantbus, 12 bunches ..	0 0		0 0	
Ranunculus, 12 bunches	0 0		0 0	
Roses, 12 bunches .. ..	2 0		6 0	
" (indoor), dozen .. ..	0 9		1 0	
" Tea, dozen .. ..	1 6		3 0	
" red dozen .. ..	0 0		0 0	
" de Moiss. 12 bunches	0 0		0 0	
Stephanotis, 12 sprays ..	2 6		4 0	
Tropeolum, 12 bunches	1 0		2 0	
Tuberose, 12 blooms .. ..	0 6		1 0	
Tulips, dozen blooms ..	0 0		0 0	



CROPPING A FARM.

THAT many a tenant farmer is prevented from laying down some portion of his land to pasture by ignorance there can be no doubt, for how frequently is advice to make more pasture of some sort or other met by vague remarks about the cost, the uncertainty of results, and the length of time required for the development of really good pasture. Such arguments are both simple and foolish, and are best confuted by pointing to examples of flourishing new pastures in the hands of really competent

men. It is, of course, understood that to a tenant farmer an immediate annual return upon all farm expenditure is a matter of vital importance. Keeping this point fully in view, we would earnestly recommend him to try a few acres of his best land in pasture. What! Put down the best corn land to grass? Yes, certainly, for we never would lay down poor land out of condition, knowing as we do that it answers just as well to cultivate it as highly for forage as for corn. It is simply owing to inferior cultivation—often to the entire absence of anything like systematic cultivation—that we see so much poor pasture, foul with water grass, and rushes, and often so wet that it will not carry sheep in winter. Never was the importance of high farming more apparent than in the present hot dry summer. Where the land is well drained either naturally or artificially, and is clean and fertile, there are abundant crops of hay, stover, roots, and corn; the reverse is the case very much according to the poverty or otherwise faulty condition of the land.

Take, for example, the hay crop. Under really good culture it was abundant enough, because the soil is kept so well stored with fertility that every plant in the pasture is in a state of robust health throughout the year. Such pasture is never really bare and brown in winter; rather has it a fresh, green, vigorous appearance, so that when the annual dressing of chemical manure is applied to it in February a full strong growth and an abundant crop of hay can be reckoned upon with certainty. There must, however, be no irregular fitful use of manure, but it must be applied annually, and our readers may rely upon our assurance that the outlay upon such manures, provided they are obtained in a pure state separately and mixed at the farm, is as sound an investment as a farmer can make. By an annual outlay for a given quantity of nitrogen, phosphorus, and potash of from 20s. to 30s. per acre he may obtain from two to ten tons of sweet wholesome forage per acre. Compare this with corn crops; compare, too, the labour required for the cultivation and harvesting of an acre of the heaviest hay crop with that involved in the culture of corn, and surely it must be acknowledged that a larger proportion of pasture is desirable upon all farms.

Heavy-land farmers whose crops are suffering from the effects of the drought may, we hope, be induced to follow our example, or rather join us in laying down from a third to one-half of such land in pasture. We have repeatedly given our own method of doing this work, and we may now usefully give that of Mr. C. Randell of Chadbury, which is undoubtedly characterised by simplicity and utility in a remarkable degree. Mr. Randell lays it down as a primary condition that the land be drained, which he wisely regards as an absolute necessity. Next it must be clean, especially from couch grass. Due attention is also given to the importance of a fine tilth for the seed bed; and he shows that if under such conditions and with favourable weather the seeds be sown in July, if aided by 5 cwt. of fish guano per acre, containing 8 to 10 per cent. of ammonia and 35 per cent. of phosphates, they will be established before winter, and if the season prove exceptionally favourable the growth may require to be eaten off in September. The mixture used by him was 1 bushel of Cocksfoot, half bushel Perennial Rye Grass, 6 lbs. Cow Grass, 2 lbs. of Dutch Clover; the per-centage of growth guaranteed being Cocksfoot 40, Rye Grass 70, Cow Grass 80, and Dutch Clover 80. He was able to procure this mixture of seeds for about 15s. per acre. The reason given for feeding off the growth in September is the very sound one that other-

wise it would be liable to injury from frost during winter. Folding of lambs is recommended then, but it must not be forgotten that many lambs in September are almost as big as the ewes, and we think either or both class of animals might be used provided they were passed over the new pasture so quickly that it is not eaten off too closely, or in other words not left absolutely bare.

Whether the seeds are sown in July or in spring with a corn crop, it is certain that under good management an abundant crop of forage can be had in the following year. If this is done especial care must be taken to mow just as the grass comes into bloom, or to feel off by folding two or three times in succession, never leaving the sheep to wander at will upon it, and taking them off altogether by the end of September.

#### WORK ON THE HOME FARM.

The ewes may now be said to be really dry, though one or two have slightly swollen udders. This is very much prevented by making the process of weaning a gradual one; first of all keeping the lambs away only in the day and letting them go back to the ewes at night, and so gradually withdrawing them altogether. All this involves some extra trouble, and some shepherds comply with orders to do it very unwillingly. A master must, however, before all things insist upon implicit obedience to a thing which he knows to be right. We always listen to the remonstrance of a good servant, and if he is right we tell him so, and commend him for speaking out. But that is a very different matter to the obstinate stupidity of crass ignorance.

Foot rot in a flock is by far too common, for we know that it might be confined to narrow limits, if not entirely eradicated; but to do this demands much perseverance on the part of the shepherd. It is the proud boast of one of our shepherds that he has cured his sheep of foot rot, and that he intends to keep them free of it in future. We have three other flocks all with some cases of foot rot, and we do what we can to induce bailiffs and shepherds to give the necessary pains and time to cure it. Our farms in hand are unfortunately so far apart that daily supervision on our part is impossible. Yet we know full well that there never was a case of foot rot yet that could not be cured by downright perseverance. There is occasionally a case that is most difficult because the foot is hot and swollen without any exterior wound; frequent bathing and poulticing is the only remedy, and in due course a cure is effected; very bad cases should be isolated and have daily attention. First of all let any loose portion of the hoof be cut off carefully with a sharp knife and sure hand, then let the foot be bathed gently with warm water and apply Gell's ointment upon the affected parts, taking especial care to work it well up between the hoofs if any soreness is perceptible, Poultices should be applied daily to very sore feet, the best thing for the purpose being linseed meal. When changing the poultice always foment the foot with warm water.

#### LETTER BOX.

Poor Pasture (J. I. K.).—1½ to 2 cwt. of nitrate of soda per acre immediately rain falls, if it falls soon, would increase the "bite" of grass in the autumn. It is of little use applying it in hot scorching weather. Your letter will be more fully answered in a future issue, which will be soon enough for your purpose.

#### METEOROLOGICAL OBSERVATIONS.

CAMDEN SQUARE, LONDON.

Lat. 51° 33' 40" N.; Long. 0° 8' 0" W.; Altitude, 111 feet.

DATE.	9 A.M.					IN THE DAY.				Rain	
	Baromet. at Sea Level.	Hygromet- er.		Direction of Wind.	Temp. of soil at 1 foot.	Shade Tem- perature.		Radiation Temperature			
		Dry.	Wet.			Max.	Min.	In sun.	On grass		
1887.	Inches.	deg.	deg.	deg.	deg.	deg.	deg.	deg.	deg.	deg.	Io.
July and August.											
Sunday .....	31	30.024	66.4	61.0	N.E.	64.4	76.5	66.9	121.0	51.8	—
Monday .....	1	30.276	65.0	57.2	N.	65.0	78.5	49.7	128.7	46.2	—
Tuesday .....	2	30.270	65.5	55.7	N.	64.7	76.3	51.6	129.2	45.2	—
Wednesday .....	3	30.332	62.4	54.6	E.	64.4	74.2	49.8	109.8	45.7	—
Thursday .....	4	30.361	63.8	55.9	E.	63.7	74.7	48.9	109.8	44.6	—
Friday .....	5	30.246	64.8	57.6	E.	63.5	77.8	64.2	117.9	46.6	—
Saturday .....	6	31.124	71.3	64.6	E.	64.3	88.5	53.8	126.3	49.3	—
		30.212	65.6	58.4		64.3	78.1	61.5	119.4	47.1	—

#### REMARKS.

31st.—Fine and hot, with frequent lightning in late evening.  
 1st.—Fine and pleasant throughout.  
 2nd.—Fine and bright, clouding over occasionally.  
 3rd.—Fine, and mostly bright though hazy.  
 4th.—Fine, bright, and pleasant throughout.  
 5th.—An almost cloudless summer day with pleasant breeze.  
 6th.—Exceptionally bright and hot.  
 The drought continues. The total fall of rain in July was only 1.07 inch, and none has fallen in the past week. Temperature still considerably above the average, but nights rather cooler.—G. J. SYMONS.





## COMING EVENTS

18	TH	
19	F	
20	S	
21	SUN	11TH SUNDAY AFTER TRINITY.
22	M	
23	TU	Royal Horticultural Society—Fruit and Floral Committees at 11 A.M.
24	W	

### THE SEASON.

**N**OT, so far as we remember, since the tropical summer of 1868 have gardeners had such great obstacles to contend with as during the present season. A lingering winter and a long, cold spring, followed by a summer that will be memorable for the absence of rain, have rendered the work of cultivation most difficult, and of maintaining the usual supplies of garden produce next to impossible, except in low-lying districts and moisture-holding soils, or where the water supply has been abundant and the labour adequate for its effectual application.

As a body we believe there is no class of men more persevering under difficulties than British gardeners, nor more determined to surmount whatever obstacles may beset their path; but no foresight, energy, or labour could prevent their Cabbages "bolting" in many districts during the early part of the season; nor was it possible that the Pea supply could be maintained over the usual period. Inconvenience has been experienced through the limited supply of those two staple crops, and the cry for crisp, juicy Turnips has been uttered in vain. Generally speaking the owners of gardens take into consideration the circumstances that affect their productiveness. It is but just and right that they should do so, for they may depend upon it that, however great their inconvenience and disappointment in the shortcomings of the vegetable supply, those of the men who have striven to the utmost to avoid it are still more keenly felt.

Though we make no pretence of suggesting that every gardener in the kingdom has done the best that might have been done under the circumstances, we do not hesitate to say that all worthy members of the craft—well-trained, thoughtful, industrious men—have laboured unceasingly to do credit to themselves and to develop to the utmost the resources at their command, and we bespeak for all such the consideration to which they are fairly entitled. Though the returns from many gardens have not been equal to those in past years, it should be remembered that in instances innumerable those charged with their production have worked longer and harder than in years of abundance.

It has been quite beyond the power of man in the high and dry districts in the south of England to maintain anything like the usual supplies of vegetables this year. They could no more do this than farmers in the same localities could insure full crops of succulent herbage for their herds and flocks. As an instance of the powerlessness of cultivators in a season like the present we find that a nurseryman who has about 40 acres of trees, shrubs, and flowers estimates his loss through causes

absolutely unpreventable at a thousand pounds. His young stocks, that ought to have been saleable in the autumn, have stood still, and he has expended more than the ordinary amount in labour in keeping them alive, or at least those of them that have not succumbed to the roasting ordeal to which they have been subjected. If that is so—as it undoubtedly is in nurseries—similar results, but on a proportionately less yet far too great a scale, must of necessity follow in gardens, because the same cause has operated in both cases.

It should be remembered, too, that the inconveniences pertaining to a season like the present do not end with the comparative failure of summer crops. The influence of the weather of the past and present seriously affects and governs the supplies of the future, and unless the rain falls and in something like a deluge, in the south of England, and possibly elsewhere, autumn, winter, and spring crops must be quite inadequate for consumptive purposes, for obviously if plants cannot be raised and planted in due time, crops cannot be perfected in their season; and by-and-by, when the rain is falling, and it may be watercourses overflowing, there will be some difficulty in enabling the inexperienced in cultivation to appreciate the fact that the limited supplies then existing will be consequent on the drought. Yet such will be the truth notwithstanding, and it may be well to record it in advance.

Rain has fallen more or less copiously and refreshingly in various parts of the kingdom, but in others gardens and fields are "burnt up" by want of the showers that occasionally promise yet do not come, or come tantalisingly in the form of a "few drops" that scarcely lay the dust. In the metropolitan district, and for miles round, lawns and pastures are as if seared, and save under exceptional conditions scarcely a tinge of green is visible. Cabbages and Broccolis are "blue" and stunted, also riddled with caterpillars and sundry pests that are invariably the most prevalent during periods of excessive heat and prolonged drought. Peas have long been devoured by a horde of thrips that could not be subdued, and the blossoms of Scarlet Runners are falling in shoals, leaving no pods behind them. Celery is blistered by the maggot that is eating the life out of the plants, relays of eggs appearing to be deposited in the leaves with extraordinary persistency, while trees in orchards and fruit gardens swarm with red spider. Lettuces form flower stems when the plants are a few inches high, and the greatest difficulty has been experienced in inducing Cabbage and other seeds to germinate or the plants to grow afterwards in the dry, hot land. Lime trees are leafless, and the foliage of Chestnuts shrivelled and brown. Such are the conditions now, and that gardens can be well furnished either at present or for some time to come is out of question.

The season will teach lessons that ought not to be lost. The owners of property will perceive the necessity of making provision for a better water supply or the storage of rain. Not half sufficient accommodation is made for collecting the water, the best of water, that falls from the clouds. We are among those who have made the necessary provision in the form of tanks, and have averted a water famine. Curiously enough, while writing this sentence Mr. Shirley Hibberd's pamphlet on the subject comes to hand, and we learn it is now sold for 6d. It is entitled "Water for Nothing," and is re-issued by W. F. Allen. The author truly says, One inch of rain falling on an acre of ground is 22,622 gallons, and he further remarks, if there are twenty-five houses on that land and

only one-tenth of the total fall is caught and saved, that is 226½ gallons for each house. Whether that is correct or not, there is much of interest in the pamphlet and useful information as to the number of gallons tanks of specified sizes will hold. It is necessary to remember the date of the work (1879), or some of the observations on page 5 will not be understood.

Gardeners will be impressed with the advantages of deep-digging and storing the land with fertility during a season like the present; of early and thick mulching; of sowing and planting in trenches; of keeping a loose surface when mulching cannot be done; and of promptly seizing favourable opportunities for planting that seldom come and quickly depart. These are some of the lessons of the season that will force themselves on the attention of the thoughtful and observant, and it is hoped to their advantage.

Now that the rain appears to be coming, let no one who has failed to establish winter crops think it is too late for planting. Insert whatever plants are obtainable of what is in the least likely to be useful, as the ground when moist will be like a hotbed, and even unpromising-looking plants may by rapid growth be of great service eventually. Let no chance be lost, and if there be nothing to plant, sow Swede and Turnip seed for affording breadths of "tops" for use in spring, also summer or winter Spinach; indeed, do everything that can be done to make the best of this, to gardeners, most difficult and trying season.

### HARDY PLANTS AND THE DROUGHT.

It is many years since hardy plants have had to endure such long-continued drought as during this summer, and which is not yet at an end. For eight or nine successive weeks the rain which has fallen has only been equivalent to the usual heavy autumnal dews. During the first six weeks no rain fell in this district, and since that time the slight showers that have fallen were in no way apparent after the sun had again shone for an hour or two. Our soil is dust dry for several inches deep, and to plant anything in this means only death. Watering seems quite out of the question, for unless water is exposed in large tanks or ponds it seems to do more harm than good, and even then it requires to be used with discretion. Though we have not felt the benefit of the copious rains reported from other places, we were fully aware of their existence by apparent atmospheric changes—*e.g.*, the cooler and more agreeable air. For newly planted hardy herbaceous plants, trees of a deciduous character, evergreen shrubs, Coniferae, or the like, the great heat of the present summer has proved very trying, and in many instances fatal. Even the ordinary bedding plants, such as Zonal Pelargoniums, Tuberos Begonias, and Calceolarias are very much dwarfed, for the Pelargoniums have made very little wood, and the Begonias, in some instances, have scarcely made any headway since they were placed out. Calceolarias, in several cases known to the writer, are shrivelled up, completely scorched, by the intense heat. Then if we look at hardy perennials, the sufferers include the Spiraeas, Phloxes, Michaelmas Daisies, Harpalium, Rudbeckias, Heleniums, Saxifraga Wallacei and *S. peltata*, Hellebores of all sections, Hepaticas, bedding Violas, though not so much as many, *Lychnis Viscaria splendens* pl., and many others.

But while so many have suffered in a greater or less degree, there are some which, on the other hand, have appeared to luxuriate under the great heat, so that we may learn a lesson—even though it may be at the cost of many a good plant—from such a summer as this. The following are some of those which are looking well—*Chelone barbata* has never perhaps been better, and fine clumps have been, and still are, crowded with a profusion of its scarlet miniature Pentstemon-like blossoms. It reaches nearly 4 feet high, and the flower spike is well furnished from the ground to its summit. It is, and has been for weeks past, one of the best plants in the garden. It has glossy spreading tufts of leaves, and the growth they have made indicates in a marked degree how well they are suited.

The Globe Thistle (*Echinops ruthenicus*) is also suited, and the same may be said of the Eryngiums, *E. amethystinum* and *E. coelestinum* being very attractive objects just now. The latter is an

especially fine plant for a dry situation, hence it will make a very useful and fine rockwork plant for the higher positions. Its average growth is 2½ feet, with a much-forked Thistle-like inflorescence, which at maturity assumes a blue tint, the same colour pervading the stems and bracts. The individual heads are rather small and numerous, which only adds to the unique beauty of the plant under notice. Aster *Amellus* and the bessarabian variety are apparently unaffected, beyond being somewhat earlier in showing flower buds than usual.

Irises, particularly the *germanica* section, have done capitally, notwithstanding they are reputedly moisture-loving plants. Iris *Kaempferi* in loamy soil and cow manure is all that could be desired. With the herbaceous Phloxes we have to "split the difference." By this I mean that the old plants, which have stood for several years undisturbed, are in a pitiable plight, while those rooted in the early summer of last year, and planted early in the autumn of the same year, are now bearing splendid trusses of bloom, and carrying their foliage almost to the ground. Those who have the twofold result before them, as I have, will not linger long as to what is best to be done in their case. I have many times urged that old stools should be discarded at three years old, and that a limited number be rooted and planted annually, so as to keep up a supply of young vigorous plants and handsome panicles of bloom. There will be no thinning of the shoots necessary, nor will the bases of the plants be bristling with small and useless shoots. Apart from Phloxes of this section we have few plants making such a quantity of surface roots, and which, in a marked degree, impoverish the soil in the immediate vicinity of the plants, consequently there is all the more reason for increased nourishment and support, and if this is not forthcoming, a languishing state and inferior blooms must be the inevitable result. There are few plants so really attractive in the border as these are at this time, so that it is only right that they should receive the treatment their merits deserve.

Sunflowers are in good condition, though not so tall as usual. *Gaura Lindheimeri* is an excellent plant for a dry time like the present, and should be grown either in the border or rockery in well-drained soil, its lightness and general elegance making it quite an acquisition among hardy plants. It is readily obtained from seeds. *Zauchsneria californica* is another fine rockwork plant, revelling in a dry hot situation, where it flowers profusely; and near by the Iceland Poppies, *Papaver nudicaule* and varieties, make a very pleasing group in their variety of colour. *Lychnis fulgens* and *Haageana* are also good plants, and the vivid colouring of their flowers with the sun full upon them is dazzling in the extreme. They are good border plants, but too seldom seen, even in good collections. Slugs are very fond of them, and this may to some extent account for their absence.

*Rudbeckia purpurea* is the only member of its genus that is doing any good with me. It is now coming into flower, though not so fine as usual. It is quite a distinct shade of colour in the garden, a sort of rose-magenta to my mind, and not that signified in its specific name. When in good form it is one of the most telling plants in our collection, but unless rain, and plenty of it, comes speedily, it will not reach its usual standard this year, although in point of height it is quite up to the average. Such, then, are a few of the many examples to be found to-day. The soil is of a loamy nature, with plenty of fibre, and has a subsoil of gravel nearly 5 feet thick. In other localities other and greater differences may be noted.—J. H. E., *Middlesex*.

### STRAWBERRY RUNNERS FOR FORCING.

THIS extraordinarily dry season has been a trying one for many gardeners who have to secure large numbers of Strawberry runners for early forcing, and other means than the ordinary layering into pots has been found necessary to overcome the difficulty of the case. "A Northerner," in this week's Journal, has pointed out various ways of getting runners forwarded by timely forethought and prompt action.

This year I had all my Strawberries for forcing potted by the last week of June, and have on several occasions been asked during the past month where I got my runners from. My answer was that they are last year's runners, at which some seemed rather surprised. Some years ago I obtained the hint in these pages, from whom I have not the slightest idea now, about saving late runners in October for forcing the following year, and I have practised it ever since.

As soon as the fruit is cleared off the permanent quarters the whole of the runners are cut off, and the straw or litter with which they have been mulched cleared away, and the surface of the soil hoed up. A second lot of runners are soon thrown out, and by the middle of October they will be well rooted plants. These are lifted and laid in nursery rows a few inches apart, where they remain till they begin to start into growth the following spring. They are then potted in 3-inch pots, plunged in ashes, the flower stems picked out as soon as they appear, kept duly watered and potted when convenient during June or early July. This I think is a good way to secure strong plants for early forcing,

and with less trouble and worry than depending on the current year's runners.

The dry season has been a very trying one for gardeners in Mid-Sussex. The total rainfall for April, May, June, and July is under 5 inches. For June the amount of rain was 0.60 inch, and for July 0.79 inch. From the 4th June till the 4th July not a drop of rain fell, and most of the time the temperature was high, with drying winds. The few showers we have had during July have practically done no good, as they have been so slight and always followed by bright hot days. The land is completely baked. Our greatest anxiety now is how to establish winter vegetables. We succeed best by making good large holes with a crowbar, soaking them well with water the day before planting, and watering well afterwards. It is also of importance to have plants of sturdy growth.—R. INGLIS.

### WASPS.

At the recent Show of the Astwood Bank Horticultural Society at Eastern Hill, Mr. J. Hiam had an interesting collection of wasps and their work, showing every stage in the making of their nests, from the two or three tiny cells first made by the queen wasp up to the complete nest. Mr. Hiam also exhibited under glass a colony of wasps actively engaged in the nest-building avocation. The object of exhibiting gardeners' enemies in the way of insect pests is to make persons more familiar with their nature and habits, and thus enable them more effectually to grapple with them. Wasps during the fruit season often prove very destructive as well as dangerous and annoying on account of their stings. Familiarity with their habits enables one to find every nest in the district, and also to destroy every wasp without a single sting, even if taken in the daytime. We have four distinct species, if not five, of social wasps, each varying in their colour, markings, habits, and nests—viz., *Vespa vulgaris*, the common small wasp, which builds its nest in the ground generally; the combs and paper surrounding the nest are brittle and fragile, so that it is difficult to handle without injury. The larger kind of ground wasp (*Vespa germanica*) builds a more substantial structure, which bears handling without much injury. These are the most destructive to fruit growers and bee-keepers on account of their superior strength in grappling with the sentinel bees, which often lose their lives in a battle if undertaken single handed.

*Vespa norvegica* builds its nests in hedges, on trees, and in bushes. These are seldom met with, and appear to do little if any harm, and live in a great measure on honey gathered from flowers and the honeydew from aphides. They appear to furnish their nests by the latter end of July, when the young queens, or princesses, come to maturity and are to be seen now in the company of the males, which have no stings, like drone bees, and which may be noticed by their long circling antennæ, in comparison with the queens and workers. *Vespa rufa* is a small ground wasp, seldom met with in this locality; their nests are similar in colour and size, and are seldom in the ground many inches, and their habits generally are similar to *Vespa norvegica*. *Vespa britannica* differs little from the two latter; the nest is generally built inside buildings, attached to rafters, &c. One was taken from a pigeon box last autumn. This is the smallest nest we get of the social tribe of wasps; the nest when finished is not much larger than a cricket ball, and is almost round, and the opening is at the bottom, whereas the hole or doorway of *Vespa norvegica* is more in the shape of a Pear stalk downwards.

A small mud nest of the species of solitary wasp (*Vespa muraria*) was exhibited. This is a little wonder of skill and instinct in providing food for the young, by placing a grub in the cell for the larvæ of the wasp, to feed upon, and then seal it up with a cap of mud, and leave the rest to nature to bring to maturity. Nests of all the species in various stages of development, from the tiny commencement no larger than a threepenny bit up to the finished and deserted nest in autumn, were produced.

The eggs, a caterpillar, a chrysalis in its cocoon, and the perfect female saw-fly, which lays the eggs on the Gooseberry and Currant bushes, were exhibited. Plum aphides, hundreds of which could be seen on a spray of Plum tree containing only five leaves. This fact was noticed by seeing two beautiful willow wrens picking them off. This species of aphid lives on the Plum trees all the winter, and finds food for many species of birds. Rose aphid, moths from the Rose maggot and thrips, hundreds of which may be seen on a single Rose bloom during this dry weather destroying the colour, especially in the light varieties. Eggs and caterpillars, in various stages, of the common white Cabbage butterfly, which promises this season to be a scourge and destroy or spoil all the "green stuff." Earwigs, and a very simple and certain way of destroying them, by which thousands were destroyed in a few weeks last autumn. The dry seasons seem to suit earwigs, and they promise to be a great nuisance as well as cause much loss of fruit and flowers. Sprays of Apple trees and Pear trees infested with small insect parasites which are believed to kill branches and eventually the trees. The Apple tree wood was off a Ribston Pippin standard, and was cankered in several places, and there the insects were by scores living on the inner bark. The Pear tree wood was from a Jargonelle, which is being killed in patches or branches, and from a very vigorous growing young tree, and not a "debilitated" tree as some writers and gardeners contend is the cause of insects attacking them; debility being caused by the continual drain of sap to supply the insects, as leeches suck the blood and debilitate human beings. A gad fly, which causes so much irritation to cattle, a single fly—the very hum of which they appear to recognise—will put a herd to rout and cause them to dash through

hedges and into pools for safety. Many other insects of minor importance were produced.

### VINE BORDERS AND UNORTHODOX PRUNING.

MR. ABBEY has set me a good example in conducting a controversy, and I give practical appreciation of his plan by following it. In the issue of May 9th (page 389) I ventured to write an article which Mr. Abbey was good enough to review on June 30th (page 526)—an interval of three weeks; on page 4 (July 7th) I gave a gentle response to his review, and he replies on August 4th (page 87)—again after three weeks of study. I have followed that example in "biding a wee" before replying to his interesting communication, and before I have done I shall ask my able and friendly opponent also to follow an example equally good, for it is set by himself.

When I first glanced at his latest critique (page 87) I had a fear lest I had said something that was not quite palatable on page 4, but on proceeding was gladdened to find that my remarks just reached him at the right time—the hot weather—and proved, as he said, a "treat" and a "refresher." I will try and refresh him again. But why is it good to wait a fortnight or three weeks? It affords time for reflection and prevents the fabrication of impulsive sentences that may not be of a soothing or refreshing nature. If you are a little vexed count twenty before you speak, was the advice once tendered by a thoughtful man to an impetuous youth; and Mr. Abbey evidently thinks it advisable not to answer hastily. He did very well in the time at his disposal, but might, perhaps, have done somewhat better for himself if he had waited another week.

What is the subject in dispute? I introduced it in the following words: "Not one word will be said against the spur system of pruning where it answers, and not one reader will be urged to change his plan of action who produces satisfactory Grapes. But there are Vines all over the country to which the system in question does not apply, and to force it on them is foolish. It may be right for one class of Vines, and it is right; but it is utterly wrong for others."

What reasonable man, be he a close pruner or not, can object to that, except for the sake of controversy and argument? I have said, and repeat it, that Vines are no more naturally adapted to the spur system of pruning than Peaches are; and a modified extension system of pruning would result in far better crops of Grapes in the case of hundreds of Vines than they can possibly bear when the bearing wood is cut off close to the main rods.

But Mr. Abbey condemns this modified extension on page 526, on the ground that an extension of young canes leads to "loose badly set bunches, stoneless berries, deficient in colour, and shanked." A greater fallacy was never attempted to be established. It has gone the round of the press long enough, one author copying another on the point with the most parrot-like fidelity. If the allegations were true, and there is so much virtue in the "spur," then no Grapes produced on it could shank, but all must be compact, well finished, and perfect. Are they?

I have instanced the Cole Orton Grapes as proof absolute of the utter groundlessness of the unorthodox or modified extension system of pruning leading to shanking and miserable Grapes. It led to the exact contrary—gold medals. But what of that? Are they not slighted? I know they are often by men who have not won them, but medals are not won with bad Grapes at good shows.

Mr. Abbey does not believe in the Cole Orton test; he seems to prefer arguments to Grapes, and I will therefore ask him to study those advanced by an authority—even himself. Mr. Abbey has said in language that cannot be mistaken, "Spur-growing and restricting the growths are not the way to get Grapes on weak Vines, and to prune vigorous ones closely is to prevent their bearing" (p. 244, September 16th, 1886). I have not said more than that. It is the very truth I have been trying to teach, and my strong supporter of a year ago now condemns me, and of course eats his own words at the same time, for he cannot do one without the other. Very refreshing.

Mr. Abbey says Mr. Henderson's "old Vines had gone wrong." Where he got that information from I have no means of knowing; nor does it matter whether it is accurate or not, for Mr. Abbey goes on to say, "refusing to answer to the spur, the rod was brought into requisition," hence the fine Grapes. I desire no stronger admission than that of the soundness of what I have endeavoured to advance, and my great opponent is my very strong supporter. Quite refreshing.

Mr. Abbey asks me what I mean by "orthodox nonsense." It is this. Cutting off the parts of Vines that would bear fruit, if permitted, and leaving those parts only that will not bear, and calling that Grape-growing. Hundreds of Vines are practically barren through that stiff and starched orthodoxy—the "weak Vines" that Mr. Abbey has told us will not endure it; and the "vigorous ones" that he says if closely pruned are prevented bearing. I am sorry there is so much of that orthodox nonsense in the world.

Then my puzzled cross-questioner goes on and says, "Tell us of a case where Vines in a cold wet border have been made by long pruning alone to yield satisfactory crops of Grapes;" and further kindly suggests if I cannot do so to refer to some "veteran." That method of cross-examination is a betrayal of weakness, and counsel who indulge in it rarely win their ease. Mr. Abbey's memory places him in a peculiar position.

Let him turn to page 174, August 26th, 1886, and he will find the following clear statement: "A few years ago some twenty-years-old Vines were lifted, and the roots spread near to the surface in a new



border; but there was one Vine perhaps a hundred years old. The roots went 'straight down' quite below the bed of the new border, which was made nearly 3 feet deep. The owner would not have the old Vine disturbed. It started later than the others, but before the summer was over the growths extended more persistently than any. The raised Vines, with roots near the surface of the border, and short-jointed wood and medium-sized leaves like stiff brown paper, near the roof, could be spurred to any extent, and never failed to produce excellent Grapes; but the old Vine pruned similarly was a complete failure; yet with young canes trained in as many Grapes were obtained and as good as from any Vine in the house."

I will now ask him to read a comment on that statement. It is this: "In a mixed vinery I once had charge of was a Vine labelled Alicante. It was an old vinery planted in 1837, roots all outside. The other Vines were fairly satisfactory in fruiting, but this particular Vine was sterile. Its roots went straight down by the wall; subsoil clay over freestone. They were in a cold wet medium, bare and fibreless to the depth of the border. Nothing was allowed to be done at the roots. The Vine must not be touched. The growth was gross as to length, long-jointed, and though it was late in starting it soon out-distanced all others in growth. It must be kept to its space, therefore was stopped, and it showed fruit on the laterals—poor things of bunches. A cane was run up, which ripened and gave fruit the year after, which, though it did not colour well, gave satisfaction, and that was everything." Here we have a "sterile" Vine, with roots in a "cold wet medium," and nothing allowed to be done to them, yet by a change of pruning, and that alone, produced fruit that "gave satisfaction." If Mr. Abbey will not accept the accuracy of the above statement it is of no consequence, for the comment covers everything, and he cannot very well ignore that because it is his own. So that it will be seen his experience and mine are identical on the point, and why he should have asked for a "case" after he had provided one is one of those curious episodes in controversy that renders it very refreshing.

Nor is Mr. Abbey a new convert to the modified extension method of pruning that he last year applauded and forgot having done so, or he would not have asked for the "example;" but he approved of it years ago. In a description of the Vines at Chiswick in 1880 (page 139, the issue of August 12th of that year) he says, after describing the crop of 4500 bunches in the great vinery there, "The Vines were in the best of health, and owe their fertility to Mr. Barron's practice of yearly encouraging new growth to replace the older growth, a portion being cut away each season. This, while it does not overerowd, is clearly the extension system modified, and one that might be followed in the case of Vines that have been planted some years with great advantage." That is exactly what I advocated, neither more nor less, and now I am taken to task for doing so by one who has recommended the plan so forcibly, and who says not one word about border renovation as improving the Chiswick Vines; nor was it necessary, for on whatever system the Vines were pruned their roots were all alike in the same medium. That was and is precisely the case with the Vines I adduced as having been improved by the change of pruning. They were "Vines that have been planted some years" (like those at Chiswick), and to which Mr. Abbey tells us the plan might be applied "with great advantage." He is quite right, and why he should turn round, not on me so much, but on himself, is one of those peculiarities of life that are well nigh incomprehensible.

When I directed Mr. Abbey's attention to one portion of a Vine having been closely spurred, and some portion of young cane extension left on another part of the same Vine, and asked him to account for the superiority of the fruit in one part and its inferiority in the other, he first gives the reply that "the Vine had the benefit of a favourable rooting medium;" and then, no doubt feeling the weakness of the argument (as obviously the same rooting medium influenced the whole Vine, the unfruitful as well as the fruitful parts), he goes on to say the "Vine only wanted a chance and got it." Very true. The "chance" was afforded it in one part more than in the other, with the results indicated. I have since seen the experiment carried out more completely with still more striking results in the case of a very old Vine with its roots under flagstones. Mr. Abbey says I forget there are cases in which no remedy is effectual for enfeebled Vines save a thorough renovation of the borders. I forget nothing of the kind. I have said there are numbers of old Vines that would bear better if the "chance" was afforded them, even without touching the roots, and if these can be afforded an improved feeding ground so much the better. I have proved the truth of everything I have stated in my own practice, and have a great deal more supporting testimony than I have adduced from Mr. Abbey and others, that a departure from the close spur pruning of very weak Vines on the one hand and luxuriant Vines on the other, with roots beyond the control of the cultivator, is often wise, if good Grapes and not closely pruned barren rods are the more appreciated.

I will neither lead gardeners nor the owners of gardens astray if I can help it, and I have the pleasure of being the recipient of the thanks of both for having advised methods of procedure that have led to improvement and that mutual satisfaction that it is so desirable to promote, and so gratifying to see established.—EXPERIENTIA DOCET.

#### TO THE GARDENERS OF ENGLAND.

OWING to pressure of business at the time of the Gardeners' Royal Benevolent Anniversary I was unable to attend, but having read the speeches on that occasion and the success attending them, I feel bound

in gratitude to say a few words to my fellow workers. This year the death of our worthy friend, "Stevens of Trentham," as he was known amongst our fraternity, suggested to me what a boon an orphanage would be to widows and children in the event of such a distressing thing happening of any of us being called away without having had a chance of providing for a family. I am glad the idea has not fallen on barren ground, and feel sure the resulting scheme will prosper. But what I want most to notice is the speech of the Chairman at the Benevolent dinner. This speech should be written in letters of marble. After such remarks, I say gardeners have many friends, and that their services are more than appreciated. There is one other speech I must refer to, that of our noble President of the Orphan Fund. These two gentlemen have testified more to the worth of gardeners as a body than anyone whose speeches I have either heard or read. We are apt sometimes to feel depressed, but we must work hopefully and without murmuring. Let us try, then, to produce and make pleasant our occupation to the best of our abilities for our patrons and friends. I desire to thank all persons for their kind and voluntary support to the above institutions.—CHAS. PENNY, *The Gardens, Sandringham.*



#### CATTLEYA AMESIANA.

THIS is one of the Veitchian hybrids, and a plant is now flowering well in the King's Road nursery, showing its merits to the best advantage. It has two racemes of four flowers each, the sepals and petals beautifully tinted with pale rose, the latter rather broader than the others and slightly undulated. The lip is large, open, beautifully crisped at the margin, the apical half rich crimson-purple, light in the throat, where it is veined with bronze, the tube being white. The pseudo-bulbs are long, slender, and fusiform in shape, the plant in question being a strong one with eleven leaves. This hybrid resulted from a cross between *Cattleya crispa* and *maxima*, the influence of the former parent being very perceptible in the lip. There are only about seven plants in existence, five of which are in the leading collections of this country, and the other two are in the possession of American amateurs, so that some time will elapse before it becomes very plentiful; and at a recent important sale a moderate-sized plant realised a very large sum. It may be ranked amongst the best of the Sedenian productions, and that is saying much in its favour.

#### LÆLIA BATEMANNIANA ROSEA.

SEVERAL plants have recently flowered in the Chelsea nursery from the same cross as *Lælia Batemanniana*, which was recently described and figured in this Journal, and some of them exhibit slightly varying shades of colour, while presenting an exactly similar floral form. One of these has been named *rosea*, and possesses a distinct rosy shade in the sepals and petals, while a slight difference is noted in the longer and more slender pseudo-bulbs. Another variety has a predominance of orange in the sepals and petals, approaching to the tint found in *Sophrontis grandiflora*, one of the parents. It has been proposed that this hybrid should be named *Sophr-Cattleya Batemanniana*, and though the title is a somewhat cumbersome one it has the advantage of suggesting at once the bigeneric origin of the plant.

#### CYPRIPEDIUM ORPHANUM.

AT Kensington last week F. G. Tautz, Esq., obtained a first-class certificate for a plant of this hybrid *Cypripedium*, which has been flowering at Chelsea for some time. It is a pretty and distinct form, the peculiarly neat outline of the flower and its clear colours rendering it attractive. It is one of the few seedlings raised at Chelsea of which there is no certain record of the origin, and in consequence of its parentage being lost it has received the suggestive name given above. With so many minute plants to deal with and attend for a number of years before their characters are shown in their flowers it is surprising that accurate particulars can be afforded with such a large proportion when introduced to the public, and it indicates the systematic care bestowed upon them. Though there is no record in this case there is little doubt that the parents were *C. Druryi* and *C. barbatum*, the influence of which can be readily traced in flowers and habit, several characters of the former being observable in the flowers. The dorsal sepal is broad and rounded, white, veined with green in the centre, and with a dark purple shade towards the sides; the petals are about 2 inches long and half an inch broad, the margin very even, but furnished with a few dark hairs at the base, with a bold dark central bar like *C. Druryi*, and a clear purplish tint in the other portion. The lip is full, well

proportioned, rounded, polished, and of a rosy purple hue, giving much character to the flower. The illustration (fig. 16) represents a flower from the plant shown by F. G. Tautz, Esq., Studley House, Hammersmith (gardener, Mr. Cawley).

#### COLLECTING ORCHIDS.

AN Indian paper recently stated that Mr. Curnon, a collector employed by Messrs. H. Low & Co., Clapton, landed some time since at Buitenzorg with a view of collecting 10,000 *Phalaenopsis grandiflora* in the South Preanger districts, and that he was also prepared to receive 5000 plants of *Vanda tricolor* and *Renanthera coccinea*. Much difficulty has always been experienced in the importation of *Phalaenopses*, as they suffer considerably on the journey, and a large proportion are usually dead before they can be placed in the cultivators' hands. More success has been attained in recent years, but even now the losses are often heavy. Frequently the collectors now accompany their cases of plants on the journey to this country, and this has been found to diminish the risk to some extent.—L. C.

#### NOTES ON TOMATOES.

THE sale of this choice vegetable is still increasing. There is not enough grown to meet the demand, and a good profit can be made if the

water, and when in full bearing a little liquid manure made of soot and sheep droppings will help them, and to have the fruit firm and of good colour a little fire heat on cold nights will be a valuable assistance, leaving a little ventilation in front and at the top of the house.—J. WALLACE.

#### A HOLIDAY IN THE SOUTH.

UNDER a scorching midsummer sun, rendered more oppressive by the parched state of the ground from the long-continued drought, I set out for a ramble in the Isle of Wight and a few other places in the south of England. The state of the weather and the time of the year were not the most favourable that one would choose whose time was limited, and consequently would be obliged to make the best of his way through all hours of the day. Fortunately, or unfortunately, force of circumstances did not make this imperative on me this time, consequently I have been able to make a few jottings which may be of passing interest to some of your readers. The forebodings about the heat soon disappeared as we sped on our way through the beautiful counties of Surrey and Hants and across the silvery Solent from Portsmouth to Ryde, passing close to the still stately looking wooden walls of Old England—"The Victory," "St. Vincent," and "Duke of Wellington." Once on the island at Ryde, and passing through by rail to Ventnor, I noticed the hay harvest was not in such a forward state there as in most parts of Surrey, although many garden crops were in a more forward state.

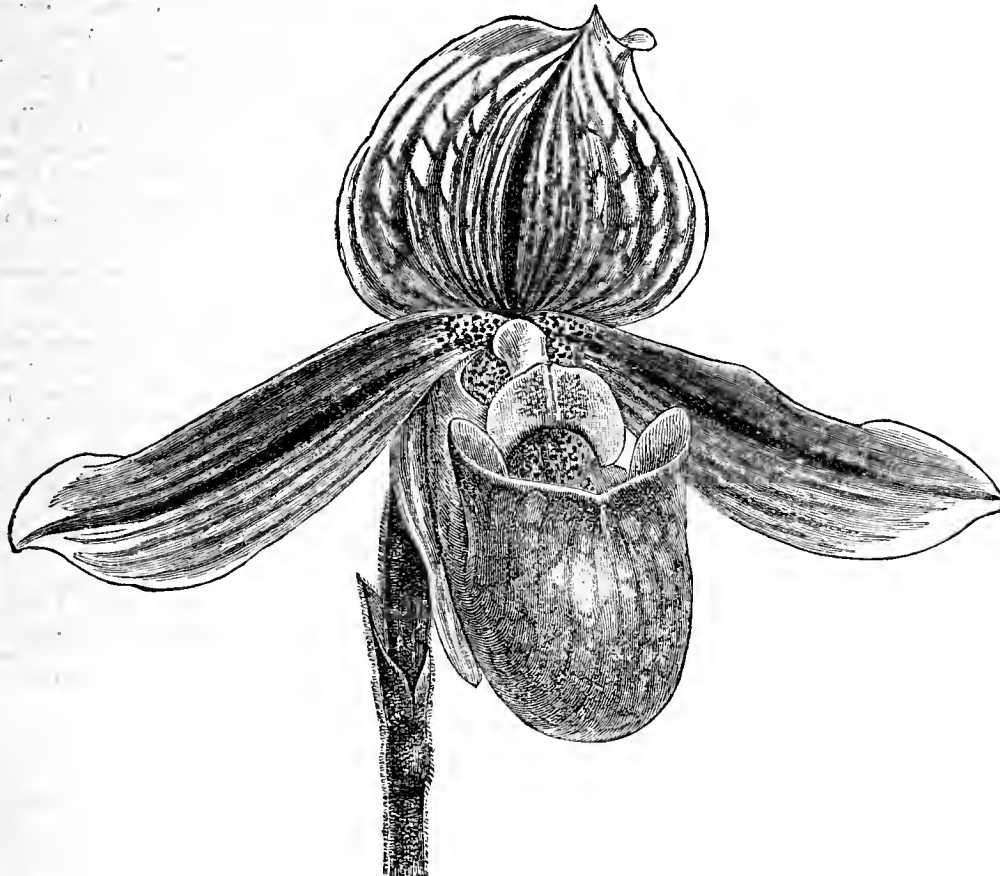

Fig. 16.—*CYPRIPEDIUM ORPHANUM*.

right sorts are well grown. I am as fond of trying new varieties as any one, but I always do this with care, and I am still growing my old favourite, a selected Old Red. This ought to have been named Royal Standard, for I find by looking at the markets it still keeps its ground in quantity above all other varieties, and in quality as well. There is no cracking with the Old Red, no shy setting of fruit, and I find it will ripen its fruit much sooner than such varieties as Trophy and Dedham Favourite. A new variety named Mikado I am trying this season; the fruit and growth are much like Trophy. These are very firm fleshed varieties, so take much longer to ripen their fruits. I do not wish to say a word against the smaller sorts of Tomatoes, such as the Grapes, Green Gage, and Vick's Criterion. These are very useful for dishing up for dessert, but they will never pay the grower for market. I have been cutting from outside three weeks from the Old Red planted against a south wall. This season is very favourable for outdoor Tomatoes, and I daresay many will wish they had planted more out. "H. W. G." (in correspondents column) had better not try the express system with Tomatoes, for they are far different from Cucumbers in their requirements. If he wishes for good fruit he must plant in a good loam, either in boxes, pots, or borders. Two feet apart I find is enough in the straight line, but if he has a span-roof house they might be planted on each side, or in a lean-to, having one row in front, another row near the path, and a third row on the back wall, placing the plants so that they are not opposite each. Keep them well pinched in, leaving only the main rod. Give plenty of air on all favourable occasions, plenty of

I can only account for this by the fact that the under grass keeps growing later. In the open parts the earth never strikes so hot here, and naturally seems much more pleasant than on the Surrey side of London.

Ventnor is known so well, and has been described by so many, that I shall not attempt any details of the place. It must be seen, not merely the main streets, but the ins and outs and nooks and corners, to get at the true character of the place, and to see the different kinds of vegetation that grow there. It is many years since I have been there at this season to see the Valerian at its best. It is at present the most striking feature in the place. It seems indigenous to the—I was going to say soil—but from stone walls and rocky cliffs it sends down long fleshy roots, in many cases to displace huge stones from the walls, and branches out in large bushy heads, ablaze with bright crimson or light red flowers; in some cases forming large banks of colour in front of lodging houses or hotels, and in others fringing the edges of rocks or cliffs with such vigour that one would marvel how it could be sustained—a plant of such a succulent nature. Ventnor has made many strides lately, and the Park and Recreation Ground form a great addition and attraction for resident visitors, but the approach from the Esplanade to the town is sadly marred by the unsightly piece of rubbishy ground, by the side of which gushes the mill stream, that might be turned to a profitable account, and be made one of the features of the town. But, of course, those that are familiar with it "can't see it." It is only the visitors that smile at their want of energy in this and other directions

notably the expense incurred in reaching the town by the Isle of Wight Railway.

The road from Ventnor to Bonchurch, *via* Spring Gardens and Madeira Vale, is delightful and most varied. At the end a sharp turn on elevated ground above the main road opens up suddenly the splendid landscape of the hills and undercliff between Bonchurch and Ventnor, which never fails to bring to a full stop all who are on pleasure bent, to note with admiration the picture of the high hills of St. Boniface and Luccombe Downs towering with an almost perpendicular green slope some 800 feet above, the valleys covered with beds and patches of Gorse. At the base of the green slope of the hills is seen the rugged top portion of the undercliff, more or less hidden by the mass of healthy green foliage of the trees that form a sloping bank at the foot of the cliffs. Nestling amongst this wood are some delightful residences, the tops of which peep out over the trees. To the right is Coombe Wood, the residence of Mrs. Huish, which includes in its domain one of the most enchanting pictures of sylvan beauty, the far-famed Bonchurch Pond. Lying by the side of the main road from Ventnor to Shanklin as this does, it has been sketched and described a thousand times. We note close to the water's edge two magnificent specimens of the Chinese Privet, *Ligustrum japonicum*, quite 40 feet high, which would be a grand sight when in flower. By the side, in striking contrast, is the grey foliage of the Blue Gum Tree on a healthy young tree that seems likely soon to obtain the like proportions. The entrance to the estate is to the right of the pond at the foot of Bonchurch Shute. On the way we stop and patronise a drinking fountain erected by the late Captain Mark Huish, domed over and fed by a natural spring. The grounds themselves are in character with the rest part of the undercliff-rocks and dells, rugged steps leading to natural terraces and grass slopes and plateaux, rocks overhanging or peeping out here and there in wild confusion, suggestive of a violent volcanic eruption, and yet all neat and in characteristic order. The rocks are relieved by creepers and sub-tropical vegetation, borders and patches of bright flowers to brighten the scenery, and the air is laden with perfume of Stocks, Mignonette, and Roses. In old nooks and corners plants grow and stand the winter that are scarcely seen out of pots in the neighbourhood of London. Close by the dwelling house is a large bush of *Choisya ternata*, which brings forth its white flowers profusely in due season, and also *Griselinia lucida*, both beautiful evergreens, which stand out all the winter here. On the lawn is a fine specimen of *Cedrus Deodara* that was raised from a seed sown in 1854, and has grown to the height of 50 feet. Near it is a fine plant of *Cupressus marocarpa*, which does well by the sea. From out of the sloping bank is growing one of the varieties of Cape Heaths with a stem of tree-like proportion, and 20 feet high, and a plant of the common *Arbutus*, 50 feet high, growing in company with the Pine and Ash trees in the plantations. *Eupatorium ageratoides* and *E. riparium* stand the winter here. *Fuchsias Riccartoni* and *gracilis*, *Aloysia citriodora*, and *Myrtles* in variety, are met with at every turn. The neat conservatory attached to the residence was gay with the usual occupants in season—Zonal Pelargoniums Mrs. Mount, semi-double, and Dr. Orton, single, were conspicuous among the deep crimson varieties. In the greenhouse we noticed an old favourite in *Lobelia ramosa*, which is sown in pots and treated as an annual for conservatory decoration. Mr. W. Cosh, the gardener, tells us that he finds it very useful. About five plants pricked into a 48-pot are sufficient. It grows about a foot high, somewhat in the way of *L. cardinalis*; flowers of a beautiful bright blue, with a white eye. In the greenhouse our attention was drawn to the ravages of a somewhat new plague in the shape of an insect like a small fly that pierces the young growth of the plants as if it was stung all over. It checks the growth of the plant, and when the foliage gets developed it is lacerated and very much disfigured. It seems to especially attack *Fuchsias* and *Colcuses*. Some fine plants, with which Mr. Cosh had won the leading prizes at the Undercliff Flower Show, had to be discarded in consequence. He has tried several thin s, but has not yet found any remedy that will check or kill it. Fruit seems very plentiful, Figs, Apples, Strawberries, and Gooseberries especially. In the kitchen garden extra fine samples were being lifted of *Cosmopolitan* and *Sutton's Early Kidney Potatoes*. At that date, June 29th, these were the finest samples we had seen of any early Potato, being of good size, shape, and quality.

Before leaving Bonchurch we paid a visit to the two churches. Although not more than 200 yards apart neither of them can be seen until you get to the very doors. The old edifice is a diminutive Norman structure, dating from 1070. It is still the delight of tourists who pass by it on their way from Ventnor to Shanklin through the Landslip. In close proximity are two very beautiful places well worth a visit—East Dene, the residence of J. Snowdon Henry, Esq., and Under Mount, for many years occupied by the late Sir John Pringle, Bart., which we were very sorry this time to pass. Adjoining the old church on the right hand is "Winterbourne." In the centre of the carriage drive opposite the front door of this house stands a very fine plant of *Fuchsia Riccartoni*, the largest, we believe, in the neighbourhood. As seen from the gates it looks to measure about 20 feet through, and the carriages drive round it. Twenty years ago there were many more of these old *Fuchsias* in this neighbourhood, especially by Bonchurch Pond, which gave quite a distinct character to the place, but alterations or other causes required their removal, and there do not seem to be many taking their places. In the very beautiful and picturesque grounds in which stand the new church are some very nice bushes of this same variety, and also of *Fuchsia gracilis*, with its more slender and graceful habit. There are many other things in this well-kept churchyard that are very pleasing

and well worth a visit by horticultural friends. Retracing our steps towards Ventnor we pass "The Maples" on high ground under the cliff. This place is noted for its natural caves in the rocky cliffs. From the roof the dripping waters make it congenial for Ferns, Begonias, and other moisture-loving plants. By the gardener's cottage is a natural fountain fed from water on a higher elevation, which was always a beautiful feature from the main road, but now it is getting too much overgrown for the pond and waterfall to be seen to perfection.

Passing along at the foot of St. Boniface Down we make a call at the pretty little florist garden of Mr. H. Drover, wherein we find much to interest us. This place was established when Ventnor was comparatively in its infancy by a retiring gardener from Sussex, who was a good old florist—the late Mr. Adam Spary, to whom the writer of this will for ever feel indebted for much knowledge and instruction. From twenty-five to thirty years ago this garden was celebrated for the collection of Dahlias, all the best and newest varieties. Tulips of the best show varieties, grown and flowered under a framework with a canvas covering, Carnations, Pansies, and a few varieties of Chrysanthemums received especial attention. It was here that the first double Pansy was raised, and at that time thought a great deal of, especially after the publicity given to it by the late Mr. George Glenny, who named it Prince Arthur, being raised the same year as our Royal Prince of that name was born thirty-eight years ago. It was of dwarf free habit, dark maroon in colour, with a light base to the petals, perfectly double, and very sweet scented. For spring bedding it would be invaluable if still in existence, but I am afraid it has now gone quite out of cultivation, for I cannot hear of anyone that has seen it for years. The plants most sought after then in the way of trade were those seen growing about the town in profusion, and which visitors felt anxious to take away with them. *Fabiana imbricata*, *Coronilla glauca*, *Veronica Lindleyana*, *purpurea*, and *Hendersoni*; *Aloysia citriodora*, *Myrtles*; and *Fuchsias*, especially *Riccartoni*, *gracilis*, *corallina*, and *globosa*; *Leyeesteria formosa*, *Buddlea globosa*, the old York and Lancaster Rose, *Coupe d'Hébé* and the *Felicité Perpetuée* white climbing Rose; a very strong-growing Zonal Pelargonium with scarlet flowers that used to cover the sides of houses in the town, and known as "Giant Geranium." These were plants at that time that could not be propagated fast enough. Time has altered all that now. The Weeping Ash tree is still there that used to form the arbour, under whose shade the merits of the latest additions to the different classes of florists' flowers were discussed and criticised by the chief and his friends; but the general character of the place itself is altered, and a different class of plants cultivated, of course to suit the requirements of the times. Considering the chalky nature of the soil, it is surprising how well plants do there. It is ablaze with flowers from end to end, showing the advantage of chalk over gravel in retaining moisture in dry weather. In the houses Mr. Drover has a good stock of the double white Primula, which he grows well, Tuberoses, Gardenias, Bouvardias, and others of that class for supplying his shop in Mill Street with cut flowers for buttonhole and other floral decorations. Double Violet Marie Louise looks healthy and strong, and is grown in preference to any other. Roses, Carnations, Pinks, Stocks, and Asters all do well, and the display will be continued by Dahlias, the Cactus varieties, White Aster, Queen of Whites, &c., Gladioli, Anemone Honorine Jobert, and other autumn flowering plants. There is also a healthy small collection of Chrysanthemums being grown in their flowering pots on the natural system, embracing some of the best varieties of the different sections.

Leaving there we next made our way to St. Lawrence, which lies to the west of Ventnor, passing under the foot of St. Boniface Downs, and past Ventnor Railway Station, up the Newport Road, to get to the path on the Upper Cliff. At the top of the zigzag road is obtained a charming birds'-eye view of Ventnor, the public Park and Recreation Ground, showing up well, with its beautiful green turf and shrubberies, and bright borders and flower beds. To the right under the cliff, standing up above a forest of sloping green foliage, is seen the tower of Steeplehill Castle, now and for many years the seat of the Humber family. Passing on by the footpath that runs through the fields at the top and near the edge of the cliffs that form the protecting wall, so to speak, of the mainland, and from which the lower or under cliff has at some time or other subsided, we still have a commanding view of everything beneath us. Beyond Steeplehill Castle the terrace of semi-detached block of buildings—the National Hospital for Consumption—is conspicuous, and preparations were in progress for the opening of another block by a member of the Royal Family. We make our descent into the lower ground by a highway known as Whitwell Street. We notice that the strips of land under the cliff were being cultivated with early market produce, and learnt that latterly part of the land was being utilised for early Daffodils and other Narcissus, as well as early vegetables for Covent Garden, in competition with the produce from Jersey, Guernsey, and the other Channel and Scilly Islands. The crops seem about a fortnight earlier than the London district. We turn a little to the left to have a peep at the smallest church in the British dominions. It is now in disuse, and a larger one has been built on the lower road for the accommodation of the inhabitants of St. Lawrence. A little further on the way to Niton, and about mid-way in the Undercliff, stands the very secluded residence called "Old Park," for years the residence of the late Sir John Cheape, but now the property of and occupied by W. F. Spindler, Esq. It is one of those—

"Quiet homes,  
Scattered at will beneath the crag's rude face,  
While springs gush round and near the ocean foams;  
What finds he like to these afar who roams?"



The generous proprietor has done much towards restoring and developing this picturesque place. With a liberal hand he has employed labour to add to Nature's requirements, by adding to and planting new belts and shrubberies on the naturally formed terraces and slopes that both surmount and underlie the mansion nearer the sea coast. It is just the place for a man of sound taste and a lover of natural scenery. Water in abundance bubbling up here and there, or gushing out between the rocks, adds to the beauty and the charm of the place. In the lake near the house *Calla æthiopica* seems perfectly at home, having been planted out with the other Water Lilies about four years ago, and stood the winter and increased amazingly. Since then they were in flower in June, and had been for two months previously. Around the latter was ordinary greenhouse Palms, &c., to add to the sub-tropical appearance. The fruit in the kitchen garden was well protected, being made completely bird proof by permanent galvanised wire netting stretched across from wall to wall, laced together, and supported by lengths of strong wire strained by the ordinary wall strainers fixed with cog wheels, and supported in the centre of the garden by one or two iron supports made from 1-inch gas pipe, both the kitchen gardens being neat and well done, and serving as a protection to the buds in spring as well as the fruit in summer; no doubt it will soon pay for itself. Outdoor fruit, which includes Figs, usually bear well here, and this year seems no exception to the rule. The ranges of span-roofed houses are full with the usual stove and greenhouse plants, and overflowing with fresh imported or newly purchased Orchids, three new houses are about to be erected for the accommodation of the latter. There is a fine breadth of land between the house and the sea cliff, and when the belts of thousands of ornamental trees that has just been planted get up, it will add to the beauty, and be a great protection from the south winds. Mr. J. Cave, the gardener, is quite at home at this work, and the condition of the plants and the general character of the place do him credit.—C. O.

(To be continued.)

### BEDDING ARRANGEMENTS AT HAMPTON COURT.

NOTWITHSTANDING the excessive heat and long-continued drought of the present summer, the bedding arrangements are quite up to the usual standard; and despite all that has been said and written against it, the Zonal Pelargonium has exhibited in a marked degree its adaptability to endure greater hardships. All that is observable is that the Pelargoniums have made less wood than usual, but this at the same time is firmer, and has produced flowers abundantly. One point, however, should be borne in mind, and that is there is a plentiful supply of water here, and hose sufficient to reach a considerable distance, with stand-pipes for supply, and having all this, the labour entailed in keeping their wants supplied is not very great. Still the great glare of colour which these plants supply stands greatly in need of modification, and this might readily be done by bringing them into contact with the "hundred and one" colours of a much more subdued and enjoyable tone; and this idea is exemplified at Hampton Court, and is at once pleasing and edifying. It is in such gardens as these that we would resort for examples in this manner; and among the great number of beds which are annually filled, it is not too much to say that even the most fastidious may find something to please his particular fancies, but he may at the same time carry away some good and useful lessons.

In the great number of oblong beds, which vary little from year to year, having for their occupants differently coloured Zonal Pelargoniums, with Coleuses, Iresine, or variegated Ivy-leaved Pelargoniums as margins, there is nothing of particular merit, while in the mixed beds, as well as in those devoted to carpet bedding, much taste and ability have been displayed. It is from these latter, therefore, that I will endeavour to give, as far as I can, the manner in which the various plants are utilised to bring about the result here obtained, in the hope that some, at least, of the readers of this paper may gather useful hints. For example, a bed filled with *Abutilon niveum maculatum*, dotted with Iresine Lindenii and *Verbena venosa*, was very pretty, while another with a margin of *Ageratum Pearl Blue*, a free-flowered, dwarf-growing, and effective variety, was planted, or rather dotted, with *Veronica Andersoni variegata* and *Tropæolum Vesuvianum*. Both these are pleasing arrangements, and are situate at the Bushy Park end of the gardens. Then there are two large circular beds, which everyone admires, and which are very well done. The first has a groundwork of *Mesembryanthemum cordifolium* fol. var., intersected in which are scrolls of *Alternanthera nana aurea* and *A. magnifica*. These scrolls are edged with *Echeveria Peacocki*, while the margin is composed of *Echeveria secunda* and *Sedum hispanicum glaucum*. The other bed has for its margin plants similar to the first, inside which is *Mesembryanthemum* and then *Alternanthera*. The main feature of the bed is occupied by a hexagon-shaped design, or star, the points of which extend to the margin. This is formed of *Alternanthera nana aurea*, with a dark variety inside, while a good plant of *Pachyphytum bracteatum* occupies the central place.

The spaces between the points of the star are occupied with *Leucophyton Brownii* sunk in small beds, making up a very pleasing arrangement. The next bed has a margin of Pelargonium Golden Harry Hieover, the main portion being occupied with *P. Flower of Spring*, among whose latter foliage the purple blue flowers of *Viola Favourite* mingle in the most happy manner possible. Such beds as this always please, and are always appreciated for the charming combination which their arrangement together supply, the dark green leaves of the *Viola* peeping out here and there being just sufficient to break the monotony

of the silver leaves of the Pelargonium. Another bed was made up of Iresine Wallsi as a margin, and *Acer Negundo variegata* with single purple Petunias planted indiscriminately. Adjoining this is an oblong carpet bed; the centre is occupied by an oval of *Echeveria Peacocki*, the groundwork is *Mesembryanthemum*, some shepherd-hook-shaped designs are formed in the last-named with *Alternanthera grandis* margined with *Echeveria Peacocki*, with patches of *Alternanthera amabilis* and *A. nana aurea* here and there. The next carpet bed design has in its centre a Maltese cross, the outline of which is dark *Alternanthera*, next to which is *Echeveria Peacocki*, the interior being occupied with *Sempervivum montanum*; *Mesembryanthemum* occupies the groundwork, in company with *Alternanthera magnifica*, small sunk plots here and there of *Leucophyton* completing the arrangement.

Opposite the entrance to the famous Vine is a bed for the most part of *Herniaria glabra* and *Mesembryanthemum*, the two being well balanced, for this *Alternanthera grandis* forms a margin, while the narrow band on the outside is formed alternately of trombone shapes of *Mesembryanthemum* and *Herniaria*. The next bed is perhaps the most effective of all, having a splendid groundwork of *Veronica candida*, which is perfection itself. Fixed in this arc crescent shapes of Golden *Alternanthera*; Iresine Walsi, closely kept, forms a cross bar in centre, with heart shapes of *Alternanthera purpurea* piercing to the centre. It is noticeable here how few plants are employed, yet notwithstanding the colours are so decided and harmonise so well that together they form one of the best arrangements in the garden. The next bed is the Jubilee bed, which exhibits a great deal of labour and painstaking. The principal groundwork is *Mesembryanthemum* and *Leucophyton*, the crowns on either side the bed are worked out in *Alternanthera nana aurea*, while the letters "V. R." and the figures "1837 and 1887," signifying the term of years forming the Jubilee, are done with *Alternanthera purpurea* and *A. amabilis*. A shield of Iresine Wallsi occupies an inner position with *Echeveria metallica glauca* as the centre, surrounded by *Kleinias*, while the ends are occupied by plots of golden *Alternanthera*, with *Pachyphytum* in the centre of each.

As a groundwork to a bed of standard Roses, *Heliotrope Lady Molesworth* was splendid; it is a good dark variety, free and abundant bloomer, and of unsurpassed fragrance. This variety, with *President Garfield*, are the only ones I noted here. But while the general bedding arrangements are carried to such an extent as they are here, and by the care and patience bestowed upon them brought to a high state of efficiency, it still remains a fact that the beds devoted to hardy perennials and herbaceous plants are not so good as they might be. So long as there are so many first-class flowering perennials to be had, there is very little reason why they should not figure in such a garden as this in place of some of the present weedy occupants, for after all who can but admire the stately and noble Hollyhock and Delphiniums, the great variety of herbaceous Phloxes now in full beauty, double and single Pyrethrums, so exquisitely beautiful in their day, German Iris, *Gladiolus*, *Liliums*, &c.? There is ample scope for enthusiasm in this direction, and I trust active measures will be taken to represent this department of gardening as faithfully as it now does the one for which it has for years been famous.—J. H.

### NANNAU PARK.

ACCORDING to Pennant Nannau enjoys the distinction of being the highest mansion in Great Britain. It stands upwards of 700 feet above sea level, and commands some of the grandest scenery in wild Wales, including from various points in the park and gardens famous views of Cader Idris and Snowdon, with the lesser mountains and intervening valleys, and also the magnificent estuary of the Mawddace, unsurpassed for its beauty. It is situated in the heart of Merionethshire, two to three miles distant from the ancient town of Dolgellau or "Dolgelley," and is held by the ancient family of the Vaughans—originally Fychans—who are descended from one of the princes of N. Wales, and consequently held in high esteem by the natives, independent of the respect they have earned by their generosity and ever-lively interest in the welfare of the people. The mansion itself—massive, but architecturally plain—was built in the first years of the present century by Sir R. W. Vaughan, the first baronet of the title, on the site of a former mansion, portions of which indeed now stand, and many stones from which bearing inscriptions are judiciously built in various parts of the present edifice, one dating from the reign of Queen Elizabeth, others bearing inscriptions in Latin and ancient Welsh characters "*Coelbren Beiraa*."

The present proprietor, J. Vaughan, Esq., has done much to improve the place. The interior of the mansion has been renovated and beautified, and contains a splendid collection of pictures and other works of art, whilst new gardens have been made and planted on an elaborate scale and in the most tasteful manner. The usual and mostly objectionable straight lines are altogether dispensed with in all the arrangements, so that we see a most harmonious combination of art and nature. At such an elevation, too, it is surprising to see the luxuriance of vegetation. The best Rhododendrons seem quite as much at home as at Waterer's famous Rhodo Nurseries. Conifere, ornamental trees and shrubs, Roses, &c., do remarkably well, the gardens abounding (particularly the old gardens) with wonderful specimens of Evergreen Oaks, Irish Yews, Araucarias, Thuias, &c., &c. The old garden referred to was for many years the wonder of N. Wales, and is to this day spoken of by the natives as perfection unattainable in this degenerate age. Some very large ornamental Yew hedges were removed a few years ago by Mr. Cooke, the present gardener, from here into the new gardens, where, notwithstanding

ing their size and age, they have thriven most satisfactorily, and prove of great benefit as shelter as well as ornament to the gardens. Indeed, I am reminded that in the shelter of one of these hedges I had the pleasure of seeing Mr. Cooke's finest prize Pansies, in the cultivation of which he has been so successful. Near this position also are annually grown the immense Dahlias that have frequently graced various exhibition tables in the principality, with the Pansies already mentioned, Roses and fruit of all kinds, as well as vegetables. To say that Mr. Cooke has in open competition entered in eight and ten classes and taken as many first prizes is sufficient testimony to his ability; added to that the fact that he planned and made the garden entitles him to front rank among present day gardeners. In the houses fruit is the first consideration, a supply of Grapes being maintained the whole or nearly the whole of the year. Besides the indispensable Black Hamburgh and Muscat of Alexandria and a few other sorts, Alnwick Seedling and Gros Maroc are grown, and thought a great deal of, particularly the latter, on account of its keeping properties, and as here grown and kept it ranks with the best of late Grapes. To its noble appearance and excellent flavour late as March I can testify, having been afforded more than one opportunity of proving it. Peaches and Nectarines are abundantly and thoroughly well grown, the former represented by such standard varieties as Royal George, Early York, Dymond, Alexandra Noblesse, Barrington, and Dr. Hogg, the latter a most useful variety, particularly for shady positions; here on a back wall in one of the vineries it finishes a heavy crop annually, "a fact that many gardeners will be glad to know." Lord Napier, Pine Apple, and Victoria are favourites in Nectarines.

A cool Peach house, "a splendid structure 100 feet long," is always interesting, not merely for the grand trees that furnish the back wall and front trellis, and afford such abundance of fruit, but also for the display of bloom that is maintained by somewhat unusual methods the greater part of the year. Maréchal Niel Roses occupy several positions on the roof, whilst standards are planted in the border behind the fruit trees, and do fairly well, though being shaded so much they are unable to ripen their wood well. Spring-flowering plants planted in the borders make a fine display early; a row of double Daisies, backed by another of Forget-me-not, being very effective. Bulbs again, Wallflowers, and Zonal Geraniums, with other simple but useful stuff planted out, affording a ready supply of cut bloom with a minimum of labour. Later in the season Chrysanthemums are the great feature in this house. It is to be hoped that Mr. Vaughan will yet improve this structure by adding a heating apparatus. A flow and return pipe would be sufficient to prevent the misfortune they are now open to of losing a crop through Jack Frost's intrusion at blooming time.

Plants, especially of the flowering class, though not a specialty, are nevertheless not neglected by Mr. Cooke. To meet the great demand for cut bloom, we find planted out in all available positions in the houses such free flowering useful subjects as Bougainvillea glabra, Heliotropes, Abutilons, Roses, Camellias, Oranges, Habrothamnus, Plumbago capensis, &c., whilst in pots are Eucharis amazonica, well grown plants, entirely free from any semblance of the disease. Roses in abundance—Begonias, tuberous and perpetual kinds, Gloxinias exceeding well done, Azaleas, Camellias, &c. For cutting purposes, late in the season as well as early, large quantities of double and semi-double Zonal Pelargoniums are found most valuable.

Many other plants deserve notice as we pass through the houses, and notwithstanding being tempted to remark upon the Orchids for the present we must leave them, as well as large quantities of standard Roses on our way to kitchen garden, unnoticed. The latter department is equally as well managed as the others through which we have passed. All crops bear the stamp of good treatment; and though this dry extraordinary season has arrested growth and caused much inconvenience, it is the careful cultivator who has suffered the least, as here manifested. Of wall fruit Cherries and Plums do wonderfully well. Of the latter Mr. Cooke speaks highly of Rivers' Early Prolific, Mitchelson's, and Denyer's Victoria, as certain croppers. Apples on the other hand, with the exception of Alfriston and a few others, are not at all satisfactory. Small fruit are abundant and good, and by liberal treatment Mr. Cooke has grown a fine lot of Raspberries that for vigour, size, and quality of fruit can hardly be surpassed.

In the flower garden we find bedding in various styles exceedingly gay, not the least so being the mixed herbaceous beds now becoming so deservedly popular, which, however, we must pass without particularising, as also the Rose garden and some rustic rockeries and stumperies which are planted with the best native and other Ferns—a good collection. We come upon large breadths of leading sorts of Rhododendrons, favourites of Mr. Vaughan, and passing some magnificent specimens of Irish Yews, we emerge into the historically renowned park, more recently noted for its venison and fine timber. Of the quality of the former I but accept the testimony of others; in appearance, however, they are somewhat smaller than ordinary, and exceedingly agile. Regarding the latter, it would, I am certain, be difficult to conceive of anything finer. The majestic Oaks, many of which undoubtedly witnessed the feuds of centuries ago, some of them now in their last stages of decay, others in the zenith of their vigour, whilst others younger, but noble examples, are well calculated to witness many more, let us hope peaceful, scenes at Nannau. Scotch and Silver Firs are represented by some of the tallest, most symmetrical and cleanest grown specimens it has ever been my lot to witness, not solitary specimens either, for the estate is well furnished with these giants. At another time I hope to be able to give figures of heights, &c. "Derwen Caubren

yr Ellyll," is the somewhat classic name in the vernacular, by which a decayed Oak in the park was known. Translated it means "Hollow Oak. Haunt of Demons." The legend relates that Hywel Sele, then occupying a mansion near the present one, was one day hunting with his cousin, the famous warrior Owain Glyndwr, with whom he was secretly at variance, and espying his opportunity he darted an arrow at Owain's breast; the latter, however, wearing armour beneath his clothes, escaped and retaliated for Howell's treachery by slaying and committing him to the Oak, where, after many years, the skeleton was discovered. Pennant, mentioning the dread the peasant has of the spot, says:—

"E'en to this day the peasant still  
With cautious fear treads o'er the ground;  
In each wild bush a spectre sees,  
And trembles at each rising sound."

Leaving the haunted spot, and with many kind recollections taking leave of our kind friends, we take a circuitous route back to Dolgelly by way of Precipice Walk, well known to tourists. Mr. Vaughan very kindly grants permission to the public to use this delightful walk, which, as its name denotes, overlooks a tremendous precipice, and commands a series of the most romantic and glorious views that can anywhere be obtained.—BRADWEN.



ROYAL HORTICULTURAL SOCIETY.—On Tuesday next, the 23rd inst., the Fruit and Floral Committees will meet at 11 A.M. in the Conservatory. The National Co-operative Flower Show, to be held on that day under the auspices of this Society, will be open to the public at 1 P.M. at the reduced charge of 6d. There will be a conference at 3 P.M. in the Upper West Quadrant, when the subject for discussion will be "Possibilities of Co-operative Allotments and Associated Gardens," by Edward Owen Greening.

— RAIN IN LONDON.—Welcome and refreshing showers fell in and around London on Tuesday night and Wednesday morning. The rain was not so copious as to penetrate the ground to any material depth, but more is hoped for for accomplishing that much-to-be-desired object. The sky was overcast yesterday (Wednesday) and the temperature cooler, but not approaching the freezing that we hear of in the north.

— FROST IN WESTMORELAND.—We learn that severe frosts have prevailed for the past few nights in Westmoreland, 3° or 4° being registered. Much damage has been done to Potato crops and garden produce.

— MR. G. MIDDLETON, writing to us on the 4th inst., from Rainford Hall, St. Helens, on the WEATHER in LANCASHIRE, observes:—"After something like eleven weeks of very dry hot weather we had on Saturday last a slight shower of rain, this being followed during the evening by a sharp frost, in consequence of which all Potatoes on low-lying and moss ground have been sadly cut and blackened."

— MESSRS. JAMES CARTER & Co., 237 and 238, High Holborn write:—"As we believe there is a desire in many quarters to inspect our TOBACCO EXPERIMENTS, we shall feel greatly obliged if you will kindly announce that anyone wishing to see the crop can obtain an order to view by applying to us."

— MESSRS. WILLIAM FELL & Co., Wentworth Nurseries, Hexham, inform us that they have received the Royal Warrant appointing them seedsmen and nurserymen to His Royal Highness the Prince of Wales.

— BULBS FOR THE LONDON PARKS.—We are desired to state that the Metropolitan Board of Works have accepted the tender of Mr. B. S. Williams, Victoria and Paradise Nurseries, Upper Holloway, London, for supplying Hyacinths, Tulips, Narcissus, &c., for Finsbury Park, Southwark Park, Leicester Square, the Victoria Embankment, and other spaces under the charge of the Board.

— AUGUST issue of the KEW GARDEN'S BULLETIN of miscellaneous information contains articles on the Tree Tomato (illustrated); the Chocho, a cucurbitaceous plant, the fruit of which is as an article of food in tropical America, and is known in the English colonies as the

Vegetable Pear. The Arracacha, a Parsnip-like plant, with a fleshy tuber, the leaves also being blanched and eaten; and the Cherimoyer, a fruit-bearing tree of the genus Anona, common in the mountains in Jamaica and fairly abundant in Madeira, whence fruit are sent in the autumn to the English market.

— THE *Daily Telegraph* reports a great storm having occurred in France. It began on Saturday night. Large hailstones fell with such fury that the crops were almost totally destroyed. At Homps houses were demolished, roofs were torn open, the Vines were cut to pieces, and large trees were uprooted and broken.

— THE monthly meeting of BELGIAN HORTICULTURISTS and the Royal Agricultural and Botanical Society of Ghent was held in that town on August 10th, when the following were present:—M.M. Jules Decock, Charles Spae, Ernest Delaruye, Baudu, François Desbois, and Moens; M. Charles Van Geert, of Antwerp, presiding; and M. Jules Hye was Secretary. Certificates of merit were awarded for Stanhopea Legeriana, from M. Auguste Van Geert; for Cattleya Eldorado splendens (by acclamation), from M. Jules Hye; and Cirrhopetalum species, from MM. Edm. Vervaet et Cie. Honourable mention was accorded to Adiantum species, from M. L. Spae-Vandermeulen; and to Microlepia hirta cristata, from M. Liévin Spae-Vandermeulen.

— MR. S. L. BOARDMAN, Secretary of the Maine Pomological Society (U.S.A.), writes as follows in *Vick's Magazine* respecting THE COLD STORAGE OF APPLES:—"Cold storage cellars, or refrigerating houses, are coming to be an absolute necessity with our orchardists who are to make commercial Apple growing a business. When in Nova Scotia, two summers ago, I visited the great Apple storage house of Knill & Grant, built on the wharf of the Acadia Steamship Company—a building 100 by 150 feet, built of brick, and having a capacity for storing 40,000 barrels of Apples. The foundation wall was of stone, the cellar bottom being 6 feet below high water mark, the walls of the elevation being 1 foot in thickness. The bottom was very moist, a flooring of loose boards resting on joist 4 inches above the earth. The temperature of this house was kept throughout the winter at 35°. On June 5th, 1884, Apples were repacked in that house which had been in there for six months, with a loss of only two barrels in 100, and the Apples sold in Boston at 5 dollars per barrel. Mr. Augur, State Pomologist of Connecticut, says there are several retarding or refrigerating houses in that State, used for the storage of Apples, and he strongly recommends the co-operative plan for their further erection among the fruit growers of that State."

— ATTENTION has been previously called to the scheme promoted by the officials at the Royal Gardens, Kew, for the establishment of minor BOTANICAL GARDENS IN THE WEST INDIAN ISLANDS. The gardens of the Windward Islands are to be in correspondence, as far as relates to the supply of useful plants, and information concerning them, with the chief Botanical Department in Jamaica. The Island of Grenada has been the first to take advantage of the new scheme. Its newly established Botanic Garden was opened to the public on July 18th. Barbadoes has recently recorded its adhesion, but the members of the group of Leeward Islands decline at present to take any part in the scheme.

— THE following summary of METEOROLOGICAL OBSERVATIONS AT HODSOCK PRIORY, WORKSOP, NOTTS, has been sent to us by Mr. Joseph Mallender. During July the mean temperature was 63.8°. Maximum on the 3rd, 85.0°; minimum on the 6th, 37.7°. Maximum in sun on the 15th, 139.2°; minimum on grass on the 18th, 31.5°. Mean temperature of air at 9 A.M., 66.7°. Mean temperature of the soil 1 foot deep, 63.5°. Total duration of sunshine in month, 228 hours, or 44 per cent. of possible duration; no sunless day. Total rainfall 1.46 inch. Rain fell on ten days. Average velocity of wind 8.3 miles per hour. Velocity exceeded 400 miles on one day, and fell short of 100 miles on five days. Approximate averages for July—Mean temperature 61.2°; rainfall, 2.36 inches. Sunshine (ten years) 163 hours. A very bright, warm, and rather dry month. The mean temperature is higher than any previous year since 1876. Sunshine more than any of the previous six years. Rainfall small, but not exceptionally so; coming, however, after a very dry June the deficiency was more noticeable. During the past six months only 6 inches of rain have fallen as compared with an average for the period of 11½ inches.

— WE regret to learn of the death of MRS. SWAN, wife of Mr. W.

Swan, the well-known gardener at Howick House, Preston. Mrs. Swan died after much suffering, patiently borne, on the 10th inst., aged forty-nine years, and many friends of Mr. Swan will join us in an expression of sympathy towards him in his great bereavement.

— SHORT COMMENTS.—A correspondent writes:—"I was very pleased with Mr. Iggulden's letter on Grapes. Mr. Abbey gave his opponent a very good reply. A little argument is just what is wanted. I think there is much to be learnt from such articles." So do we, and our correspondent can teach sound doctrine when he is so inclined.

— MRS. REYNOLDS HOLE CARNATION.—Messrs. James Dickson and Sons, Newton Nurseries, Chester, in sending us blooms of the very distinct Carnation that was certificated at Manchester under the name of Mrs. Reynolds Hole, and subsequently at London and Liverpool as Gravetye Gem, state that they have decided to adopt the name first given to it. This is unquestionably the right course to adopt, and we think this very distinct variety will become highly popular in gardens.

— IN the course of some recent proceedings taken by Mr. Edwin Andrews of Temple Mills Lane, Stratford New Town, against the Great Eastern Railway Company for compensation for damage caused to his plants by smoke from the Company's engines, it was stated that in a previous action Mr. Andrews had recovered damages to the amount of £500, but the nuisance being still continued, and his business suffering in consequence, he brought a further claim, which was submitted to the arbitration of Mr. Christopher Oakley in the Royal Courts of Justice. The ground is also to be valued with a view to the Company purchasing it. The claimant stated in his evidence that he took two acres of land in 1872, starting with a capital of £50; he was very successful in the cultivation of Cucumbers and flowers for market, and by 1878 his net profits, after deducting some £150 for living, were £500 per annum. He considered that he could have developed his business to the extent of £1000 a year, but he estimated the loss of stock spoiled by the smoke during the past three and a half years to be £200. The evidence of numerous scientific and practical witnesses was taken to prove the injury complained of, and the inquiry was adjourned.

— READERS interested in meteorology may find something to suit them in THE LONDON WEATHER CHART FOR 1887, by Mr. B. G. Jenkins, F.R.A.S., published by Mr. R. Morgan, 33, Weston Street, Norwood, S.E. It is said to be based on the author's paper on "Forecasting the Weather," recently published in the Bulletins of the Royal Academy of Belgium, and it gives in tabular form a forecast of the weather from June to December, 1887. It gives the supposed reading of barometer, thermometer, rainfall, and direction of wind.

— THE following note on the IRRIGATION FARMS IN AUSTRALIA has been sent to us for publication:—"Mr. J. E. Cracknell of 5, Westminster Chambers, Victoria Street, London, who recently travelled over the lands about to be irrigated from the river Murray in South Australia and Victoria, received on Monday last intelligence that 6000 acres are now ready, and being offered for settlement, and that 2000 persons have already made selections in the Mildura and Bookmark districts. Mr. Cracknell visited these places, and saw all kinds of fruit growing luxuriantly on portions of the land already irrigated by private enterprise, and brought home a sample of the soil. Great public interest is awakened in Australia by this irrigation work, the success of which will lead to the adoption of similar plans in other parts where the absence of periodical rains occasions great loss."

#### THE MANRESA VINE.

MANY large Vines in different parts of the country are notable, and have been described in this and other Journals, but sufficient attention has scarcely been given to the example under notice, and designated the Manresa Vine, because it is growing in the gardens of Manresa House, Rochampton. It may not be the largest Vine in the kingdom, that distinction, according to the records in Mr. Barron's excellent work (a new edition of which we believe is in the press), being attributed to the Black Hamburgh at Kinnel House, Bredalbane, Scotland, which is said to cover 4275 superficial feet of roof space. According to the same authority the celebrated Cumberland Lodge Vine fills a house 138 feet long and 24 feet wide, and he remarks is nearly twice the size of the Hampton Court Vine. Mr. Barron also describes a celebrated Vine at Finchley, which when six years old entirely filled a house 90 feet in length and 18 feet in width, while the Sillwood Park Vine occupies a structure 128 feet by 12 feet. Those are all Black Hamburghs, and all remarkable. The Manresa Vine is also a Black Hamburgh, and quite



worthy of being associated with the famous examples referred to, even on the score of size alone, for 3825 square feet of glass are requisite for covering it, while as regards training it has no superior, if an equal, amongst the other celebrities.

The Manresa Vine was raised from a cutting by the present gardener, Mr. M. Davis, twenty-six years ago, and planted against a wall in the garden with the object of growing leaves for garnishing purposes. It grew so well that one of its rods was wrapped in haybands to a length of 21 feet and carried across the walk to a neighbouring house unheated, and a house (heated) 70 feet long was erected over the Vine itself, the wall against which it was originally planted being removed. For two or three years it bore a succession of fruit—namely, in the heated and unheated structures, and in the open air, for one rod was trained

method of training it will be seen that the bunches hang with very much the uniformity that is presented when crops are cut, "bottled," and arranged on racks in a Grape room. When viewed from one end of the house the long rods and rows of Grapes, converging to the stem of the Vine, the sight was extraordinary, and perhaps unparalleled.

But the full extent of the house and Vine cannot be "taken in" at a glance, because the Vine is not planted at one end, but at a considerable distance from it, the twisted rods reaching practically across the border, and from there they extend to each end of the structure. Obviously our artist could only sketch one portion, the longer, and the result is seen in the engraving (fig. 17), together with a near view of the main stem and base of the rods before they reach the roof. He has managed also to give a not very bad outline of the cultivator—as fine a

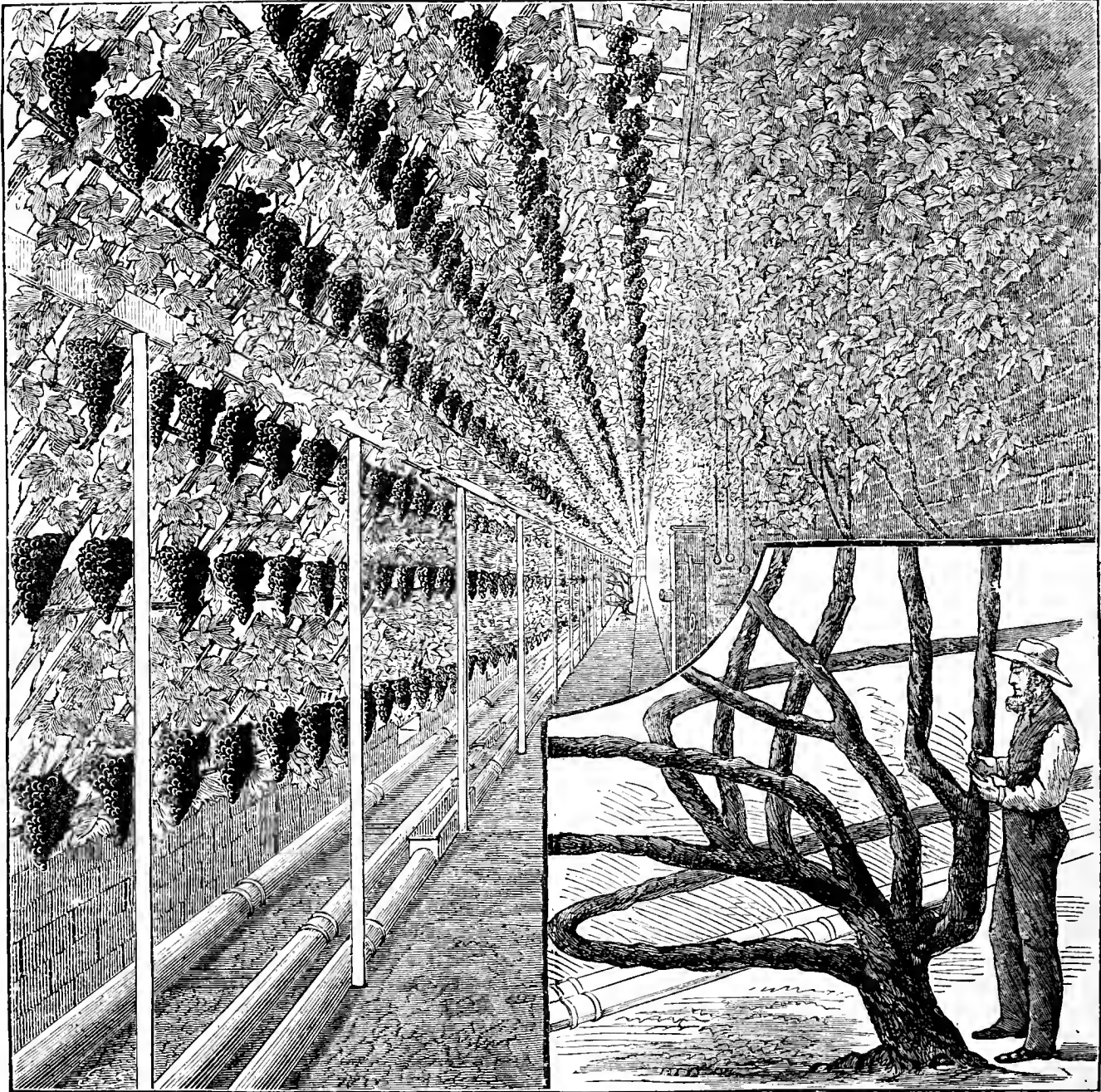

Fig. 17.—THE MANRESA VINE.

under the coping of a wall outside. The growth was so rapid, and the prospect so encouraging, that the present structure was erected. It is a sharply pitched lean-to facing south-east, with a short hip of about 18 inches from the top of the wall. The height of the back wall is 12 feet, the front a foot or so, the width of the house 11 feet, but as the apex of the hip is the distance indicated from the wall, and a little above it, it will be seen that the roof is rather steep—an angle of 50°. The length of the house is 224 feet. Under this roof seven rods are trained horizontally, the lower one just so that the bunches of fruit hang clear of the hot-water pipes, which are close to the ground, the upper rod under the apex, the other five rods equidistant between, or about 2 feet apart. They are as straight as Vine rods can be, and no laterals are allowed except from the upper side, these being a foot apart or so, and trained upright, or rather in the natural slanting direction in which they grow to the rod next above them, and there stopped. Generally speaking, every alternate lateral is allowed to carry a bunch, but the rule is not rigidly adhered to, regard being paid to the weight of the bunches and strength of the laterals, the crop being regulated accordingly. By this

specimen of a gardener under as fine a Vine of his own raising and growing as ever were seen together.

The seven rods stretching from the stem to both ends of the structure represent an aggregate length of 1400 feet, or considerably more than a quarter of a mile. But what of the crop? It must be said to his credit that Mr. Davis is not a greedy man, who leaves all the bunches that show to make a sensation number. He has the good sense not to overcrop, and the courage to remove freely, and this year he removed 1800 bunches before thinning, leaving a less number than usual, or 625, but not a few of these are between 3 lbs. and 4 lbs. in weight, and few below 1 lb., while many of the berries exceed 3 inches in circumference, and in colour and finish leave little or nothing to be desired. Last year 807 bunches were cut from the Vine and sold in the market for £107. The wood is short-jointed, strong, firm, and with little pith, and the leaves, to employ the gardener's expressive phrase, "like leather." So stout are they that the Vine pest, red spider, could make little impression on them, but this enemy Mr. Davis keeps out of the house, his antidote being ammonia rising from nearly fresh horse droppings, with

which the soil is covered, and these frequently sprinkled with water. The vapour thus rising he considers bad for the spider and good for the Vine. He is no doubt right in his surmise, and certain it is that not an insect can be seen, while the wood, foliage, and fruit are indicative of the best of health.

But what a large, deep, fertile, well drained border must be required for the sustenance of a Vine like this! some reader may possibly soliloquise. No doubt those requisites are provided, but in a natural manner, for no stereotyped border was made. The soil is good and deep—a free clayey loam. Inside top dressings, as mentioned, are given. Outside the ground is well cultivated, and the Vine roots extend to a great distance. In some gardens the natural soil will not support Vines, and specially prepared borders must be provided; in others the soil contains most of what Vines need for their sustenance; it is, however, not always allowed to support them, but is carted away and fresh soil carted in not nearly so good as the original. No such mistake

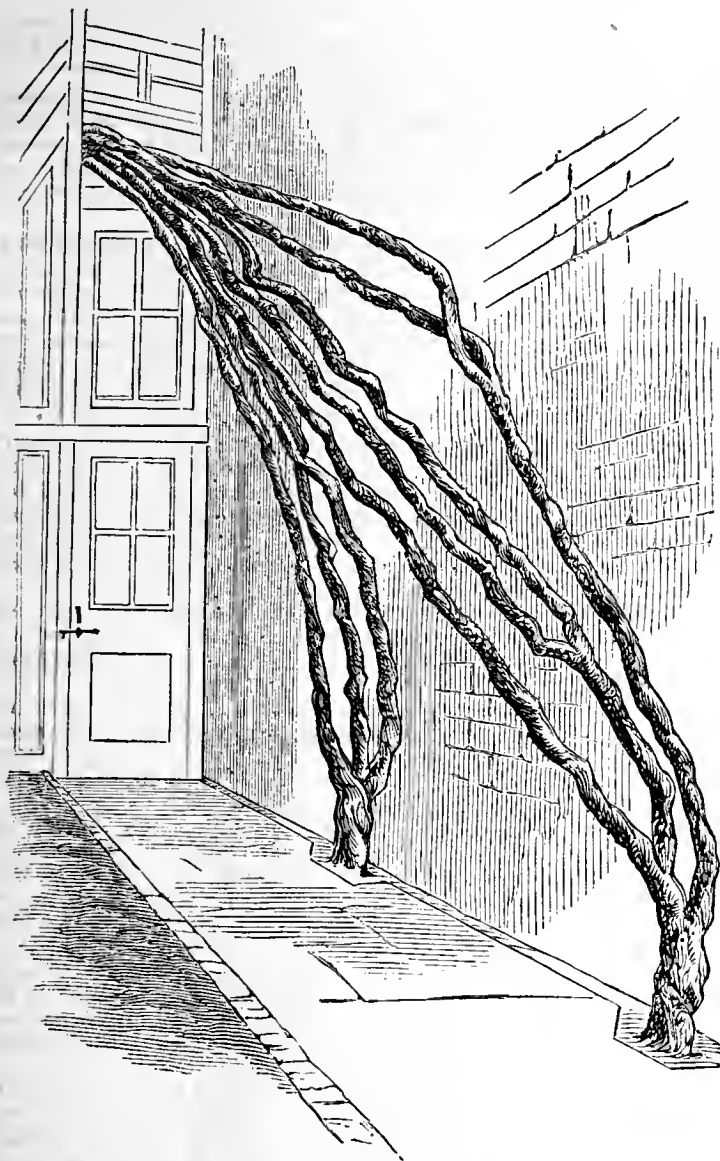

Fig. 18.—Vine extension at Mauresa.

was made at Mauresa House, and common sense culture has built up this remarkable Vine in question.

It is pruned on the spur system, and the rods have never been peeled, and it may safely be said they never will be so long as it remains in the charge of Mr. Davis; and this will be, no doubt, as long as he lives and loves to labour. He is a man of resource and ability, and has won the confidence and respect of the great establishment for which he caters—a Roman Catholic collegiate establishment of 145 students, and after providing these with garden produce he sold a surplus of five tons of fruit grown under glass last year. Such good work deserves recognition; not on the part of his employers alone, for that is generously accorded and required, but in the columns of the gardening press where well won success is, and ought to be, registered by whomsoever achieved in the art of cultivation.

Two other Vines merit a passing notice. Near one end of the large house a Vine was planted against the back wall. Its rods are taken like great cables (see fig. 18) above the top of the door, carried through a glazed tunnel, dip down, and are trained horizontally, filling a house 70 feet long. At the end of this another Vine is growing against a wall in the garden, from which rods are conducted under the walk into an unheated house 156 feet long, which they are just filling, so that before long a range of glass 454 feet long will be completely occupied with four Vines; but they could not be trained in the method described and succeed so well under a very flat roof; nor could such results be attained by

other than a gardener who knows his business, and does it not as a duty that is irksome, but an occupation that is pleasurable.

Many Vines are grown in other houses in the ordinary way—that is, the rods trained up the roof from the base to the summit, and they bear excellent crops. They are, however, being removed gradually in favour of the extension of horizontal rods from a strong Vine in the manner above alluded to, but these are being inarched to a Vine here and there with which they come in contact to “give them a lift” on the way.

Reverting to the great Vine in question, Mr. Maurice Noel, who saw it in spring, has graphically written, “Looking down the length of the greenhouse, it is hardly possible to believe that the far-extending rods all spring from the same stem. With what power must the sap be forced along! What a mighty heart must be beating, one would think, somewhere down amongst the roots! If in the early spring-time, when the fresh sweet leaves, delicate and transparent, begin to show themselves, the great Mauresa Vine is so pleasant a sight, how glorious must it appear when covered with foliage and empurpled with the swelling clusters which crown the fulness of its glory.” It was in its “glory” a week ago, but its “swelling clusters” are fast being cut and sent to market.

On another occasion an innovation on growing wall fruits will be described. It may be fairly called the Davisian method, and is simple, profitable, and economical.

### ELFORD HALL, TAMWORTH.

THE above fine old mansion with its parks, gardens, woods, river, and well cultivated farms forms one of the most desirable and picturesque of residential estates to be found in the Midlands, and is at the present time of especial interest to gardeners on account of the high-class gardening now carried on there under the direction and superintendence of Mr. J. Udale, a name well known to readers of this Journal.

The Hall is situated about five miles from Tamworth and six from Lichfield, overlooking the river Tame, which at this point is about 80 yards in width, and has a beautiful lake-like aspect as seen from the grounds. The Hall was built by the late Earl of Berkshire, was afterwards for a number of years occupied by Lady Andover, and afterwards by the Honourable Mary Howard, a direct descendant of the first Duke of Norfolk, and is now occupied by the Hon. Eleanor Bagot, aunt to the present Lord Bagot of Blythefield. The Hall and estates, which comprise an area of close upon 3000 acres, are the property of Howard F. Paget, Esq., who resides upon the estate and possesses the esteem and respect of the whole of his numerous tenantry and dependents, from the fact that he endeavours to secure the comfort and well doing of all. The workmen's cottages upon the estate, some of which have been built by Mr. Paget, are models of what is desirable in such buildings, and I fancy must often cause working men from other districts to envy the fortunate occupiers. The estate now comprises what was formerly the two estates of Elford and Fisherwick, the dividing line being formed by the river. Fisherwick Hall was occupied by a former Lord Donegal, but was pulled down about seventy years since, excepting what was the laundry, which is now a farm house, and the courtyard with stables. The garden walls are still standing, enclosing about four acres, which have long been allowed to run wild except a small portion cultivated by the gamekeeper. In the woods immediately surrounding these old garden walls are some grand specimens of choice and rare fruit trees, as for instance a Tulip Tree (*Liriodendron Tulipifera*) 50 feet high, the stem 10 or 12 feet in circumference, and with an immense sweep of branches; *Cedrus Libani*, the largest I have yet seen, stem 13 feet 6 inches in circumference, branches covering an area of nearly 100 feet in diameter; several specimens of Turkey Oaks (*Quercus cerris*) and of Hickory (*Carya alba*), also one of the deciduous Cypress (*Taxodium distichum*), all similar in size to those above described. Fisherwick Park, which faces the Hall, but is on the opposite side of the river, is about 100 acres in extent, and is splendidly timbered. A grand example of Scotch Fir (*Pinus sylvestris*), standing in the Park, has, I believe, scarcely its equal for beauty and grandeur in the country, and is alone worth a long journey to see.

Recrossing the river to Elford we notice on the east front of the mansion is the flower garden, in which the bedding arrangement consists of four groups of geometrical beds, eleven in each group, most of them being of large size. The four groups form a square and cover an area of 1300 square yards. In the centres of the larger beds forming the corners of the groups are some fine trees, one in each bed, of *Acer Negundo variegata*, which are very effective, especially as seen from a distance; also in others of the beds are some fine plants of *Dracena australis*, which contrast effectively with the drooping heads of the *Acer*. The beds are effectively planted, some 16,000 plants having been used for the purpose, and consisting mainly of *Pelargoniums*, *Calceolarias*, *Lobelias*, *Petunias*, &c. One predominant style or tone of colouring marks each separate group, and each differs from the others; the whole combine to make an excellent display, somewhat highly coloured, but not too much when the heavy masses of dark-coloured foliage on the surrounding trees are considered.

Trained to the same front of the Hall is a very large *Magnolia grandiflora*, which every year produces hundreds of its fine flowers. In the conservatory, which is at a little distance from the Hall, is a fine display of *Pelargoniums* and *Schizanthus*, the latter which are from seed sown early this spring, and which are grown three plants in each 7-inch pot, without any pinching or stopping, are masses of bloom, and are very effective; in this house also was a fine specimen of *Rhynchospermum*



jasminiflorum, loosely trained on a balloon trellis, which has been loaded with flowers. On the wall outside is a large plant of the beautiful yellow Tea Rose, Perle de Lyon, covered with grand blooms, and apparently quite at home.

Some very large and healthy Hickory trees are met with in various positions on the extensive lawns, which Mr. Udale tells me fruit abundantly. In the churchyard I noticed also a fine Almond tree bearing a heavy crop of fruit. The fruit walls surrounding the kitchen gardens are nearly a quarter of a mile in length and planted with fruit trees upon both sides, thus giving half a mile of fruit trees to be kept in training.

Such varieties of Pears as Glou Morceau, Winter Nelis, Bcurré Rance, Bcurré Diel, Williams' Bou Chrétien, Marie Louise, &c., do unusually well here and produce very fine fruits. On a wall adjoining the vineries we noticed a very fine *Wistaria sinensis*. One portion of this tree trained over a flue flowers much earlier than the other, and this portion is now producing a second crop of flowers from the ends of the lateral growths.

A glance through the vineries is a treat to all who are interested in first-class Grape culture, and especially the early house, which now contains a heavy crop of Black Hamburgs, ripe and ready for the exhibition or dinner table, which, for size of berry and high finish, have, we believe, scarcely ever been surpassed, and seldom equalled. Mr. Udale has already made his mark in the horticultural world as a Chrysanthemum grower, and will probably do so as a Grape grower. Much of his success is due to the experience gained by him nineteen years since at Garston, Liverpool, under that renowned cultivator Mr. Meredith. The larger bunches will weigh over 2 lbs. each, and the berries are many of them 4 inches in circumference. The foliage is very large and stout.

In the late house the Vines are equally satisfactory in appearance, and the crop promises to be quite as good as those in the early house. In the Peach house good crops of Peaches and Nectarines have been gathered, and from what I saw of those still left have been very good. Some Elruge Nectarines then gathered were the highest coloured samples of that variety I have yet met with, and were of very rich flavour. From a span-roof Cucumber house adjoining over 400 Cucumbers have been cut during the past two months, and still the plants are vigorous and productive. In the frame grounds adjoining are about 400 Chrysanthemums, very strong and healthy, showing that Mr. Udale's love for this flower is still as strong as when he was at Shirecliffe, Sheffield. In the kitchen gardens are excellent crops of all the most useful vegetables, and every part is remarkable for its freedom from weeds and general trimness.

One of the features of Elford Gardens are the fine herbaceous borders, which are about 5 yards wide and 100 yards long, on each side of a broad gravel walk which leads up to Mr. Udale's residence. The backgrounds to these borders are formed on the west side by the garden wall, and on the east by a grand old Yew hedge about 10 feet high and 4 feet through, thus forming a most beautiful avenue, bounded at the north end by the gardener's residence as aforesaid, and at the south by a large rockery and some fine specimen Hollies. Amongst the most strikingly effective of the many good plants then flowering on these borders first place must be given to some noble clumps, 6 feet or more in diameter, of *Spiræa Aruncus*, a large clump of *Spiræa alnifolia*, several clumps of *Spiræa ulmifolia* and its variegated form, some magnificent bushes of border Roses, conspicuous amongst which was Paul Ricaut, bearing bushels of fine flowers. *Dietamnus Fraxinella* was also very beautiful, also *Lycnis Flos-cuculi* fl.-pl. Amongst a host of good plants on these borders, some of which are now in flower, some over, and others yet to come and which keep up a successive display are, besides those named, *Tritoma uvaria*, double and single *Pyrethrums*, herbaceous *Phloxes* (a good collection), *Hollyhocks*, *Delphiniums*, *Veronica azurea*, *Boeonia cordata*, *Saxifraga palmata*, herbaceous *Pæonies*, *Lysimachia thysiflora*, *Michaelmas Daisies*, *Iris germanica*, *Phlox setacea*, *Clematis*, *Aquilegia*, *Potentilla double*, *Chrysanthemum maximum*, *Alstroemeria aurantiaca*, *Hesperis matronalis* fl.-pl., *Campanulas*, *Solomon's Seal*, *Fuchsia Riccartoni* (fine), *Lilium candidum*, &c. A notice of these borders would be scarcely complete without mentioning the fine appearance and substantial character of the gardener's residence, a modern built large square red brick structure, which like all similar works carried out by Mr. Paget, is very commodious, and fitted throughout with every convenience.

About half a mile from the gardens and upon the Elford estates are some majestic old Oaks, than which, I believe, finer are scarcely to be found in the kingdom. One of these, lately dead, having been struck by lightning, but still standing apparently quite sound to the core, is supposed to be upwards of 1000 years old. It is, I am told, mentioned in *Domesday Book*. The girth of its stem at 4 feet from the ground is more than 20 feet, and the circumference of its gnarled roots at the base is 18 paces or yards. This has, indeed, been for hundreds of years a veritable monarch of the woods, defying age and storm.

In addition to his responsibilities as head gardener, Mr. Udale has also the supervision of the extensive woods and general estate work as to repairs, &c., needed, for all of which duties he is well fitted.—W. K. W.

## DESCRIPTIONS OF AURICULAS—WHITE-EDGED.

(Continued from page 124.)

*Ashworth's Regular*.—A small plant that produces a medium sized flower of fair average goodness. Pip slightly pointed with narrow petals,

flat; edge good; colour dark mahogany, wavy, of proper breadth; paste round, good; eye greenish yellow, anthers visible. Foliage curled, serrated, slightly mealed.

*Campbell's Robert Burns*.—A pretty feminine-looking flower with neat evenly mealed foliage, having a tint of straw in it. It is not a full trusser, and can rarely be shown owing to the narrowness of its two outer zones, the edge and the colour, though in this it is inconstant. Pip large, inconstant, some being round and some angular on the same truss; edge good white, too narrow; colour plum, not always wide enough; paste good, broad, defined; eye generally too large, pale yellow, cupped with anthers in the hollow.

*Cheetham's Countess of Wilton*.—Of average properties for a white edge. Pip round, moderately flat, petal small; edge hardly decided enough; colour dark chestnut, splashed with meal, of sufficient breadth; paste good, circular; eye browned lemon, anthers low; foliage curled, serrated, without meal.

*Clegg's Crucifix*.—A coarse looking flower. Pip large, round, curls; edge good white, colour broad, black, in rays; paste good, uneven; eye lemon with projecting anthers; foliage much mealed and serrated.

*Gairn's Model*.—Large growing plant with curled and mealed foliage. Pip too small, round; edge good white; colour very deep plum almost black, well proportioned; paste good, circular, defined; eye greenish orange yellow, rather too large for the size of the flower; anthers not projecting; fair trusser; no improvement on Earl Grosvenor, which it most resembles.

*Heap's Smiling Beauty*.—One of the few whites to rank with Taylor's three celebrities, which it does even with *Glory* the best of them. Pip round and flat, not always large enough; edge good white; colour very dark velvety plum with a dash of violet in it, well proportioned; paste even and circular, and where the eye admits of it broad enough; eye full, greenish yellow with low anthers; magnificent trusser. Foliage curled, slightly serrated, evenly mealed. This year, 1860, this variety gave me my premier truss, indeed I never saw one that excelled it.

*Hepworth's True Briton*.—A fine thing, and when white enough in the edge inferior to none. Pip as perfectly circular as can consist with a too uneven surface, for it does not flatten, petals very broad and fine; edge generally undecided; colour very dark plum, well placed; paste good, round, defined; eye bright yellow, open though not large, moderately low anthers. Foliage clean, smooth, veined, dark green, fleshy, and so impatient of overwatering.

*Hufton's Miss Willoughby*.—Pip not flat nor circular enough; edge decided but of insufficient breadth; colour plum, too broad; paste thin, circular, eye greenish yellow which fades, low anthers. Foliage broad, smooth, evenly mealed.

*Hughes' Pillar of Beauty*.—A very bold flower not worth much now. Pip large, round, curled; edge good white, which contrasts the better with the deep black colour because it is splashed into by the latter; paste of good substance, uneven; eye lemon, with forward anthers. Foliage curled, slightly serrated, evenly mealed.

*Lee's Bright Venus*.—Large growing plant, with curled and serrated foliage, evenly mealed, stout stem, and good trusser. Pip moderately flat, circular, with points; edge but moderately white; colour dark maroon; paste scalloped; all the zones cramped by the size of the eye, which is immoderate and open, of a deep greenish yellow, with visible anthers.

*Lee's Earl Grosvenor*.—A late bloomer but a good one. Pip moderately round and flat; edge good white; colour dark chestnut of fair breadth, bold; paste good, occupying at least its fair proportion; eye greenish yellow, rather bold, anthers low; foliage curly, slightly serrated, mealed. Quite as good as *Gairn's Model*.

*Lightbody's Mrs. Headley*.—Not yet let out, and the raiser hesitates about it because of its habit of cupping. The plant sent me on trial certainly did not flatten its flowers, but its properties are so good that I for one am loth to entertain the idea of discarding it. Pip purely circular with large petals, which opens like that of *Matilda*; the edge was not white enough; colour broad but even, of a rich deep brown; paste of good substance, well defined; eye greenish-orange with a tinge of brown, anthers even with the surface. A small grower with a semi-mealed foliage.

*Lightbody's Countess of Dunmore*.—Not a first-rate flower. Pip small, fairly round, rarely flat; good white edge, narrow; colour chestnut, not always sufficient; paste occasionally too thin, sometimes good, narrow; eye orange, proportionate, anthers even with the surface; foliage plentiful, serrated, handsome, fully mealed; full trusser.

*Popplewell's Conqueror*.—Large, broad petalled, round pip, tolerably flat; edge not white enough; colour chestnut, too narrow; paste good, but angular; eye twice its proper size, open, deep yellow; foliage large, mealed.

*Pott's Regulator*.—A good flower though of undecided edge. Pip hardly flat enough, fairly rounded; edge often no more than grey; colour good dark chestnut; paste good, circular; eye greenish orange, small, with low anthers; in general not a good trusser. Foliage bold, light green, without meal.

*Smith's Ne Plus Ultra*.—Pip of good size, of the flattest, very pointed; edge white; colour deep chestnut, starry, might be broader with advantage; paste round; eye too large, greenish yellow, with low anthers; good trusser. Broad, smooth, mealed foliage, constitution robust.

*Summerscale's Catharina*.—Nothing to boast of. Pip of good size, angular, crumpled; edge fairly white; colour dark plum, of sufficient



breadth, but starry; paste sufficient, starry; eye orange; foliage mealed and serrated.

*Taylor's Favourite*.—Pip pointed, very flat; edge good white, not equal to *Glory*: colour very even, almost to tameness, dark velvety maroon; paste circular; eye orange. Foliage silvery green, deeply serrated, slightly mealed. Good trusser. Handsome both in habit and flower.

*Taylor's Glory*.—The best of Taylor's three, and perhaps of all white edged Auriculas. Pip a circle, flat; edge pure white; colour light-purplish plum, of good proportion; paste circular, substantial; eye light yellow, bleaches; anthers hidden. Foliage smooth, handsome, evenly mealed. First-rate trusser.

*Taylor's Incomparable*.—Fine handsome plant with a good flower, though the least so of Taylor's three. Petal pointed, but pip flat; edge hardly white enough; colour dark plum, with a dash of slate in it, running into the edge; paste of good shape, defined, too narrow; eye lemon, with anthers quite visible enough; good trusser. Foliage seaweily mealed, serrated, robust.

(To be continued.)

## THE INSECT ENEMIES OF OUR GARDEN CROPS.

### THE GRAPE.

(Continued from page 316, last vol.)

JULY appears to be a month in which that deadly foe of the Vine, *Phylloxera vastatrix*, comes forth winged, and therefore it is a suitable time to notice the species, since some authors have laid stress upon the fact, believing that it may largely extend itself in this fashion. Stories, more or less coloured, are told of these insects being seen, flying in clouds, about the Grape-yielding districts of the Continent. A little consideration, however, of the probabilities of the case, and the known history of this *Phylloxera*, will lead us to the opinion, I think, that the insect does not, by this means, reach new localities, and that it has travelled from one country to another by means of the root-feeding imperfect females. Aphides, as I have had occasion to point out in this Journal, do now and then journey greater distances than is commonly supposed, but I doubt if a winged *Phylloxera* can travel a mile, or anything near that. It may be added here that the period of flight is uncertain, lying between July and September, or even October.

Several of my friends own to being much perplexed by what they have read about the *Phylloxera*; "they can't make head or tail of it." Literally, it is frequently difficult to discern head or tail on the insects when we take them out for examination, many being in a nymph-like condition, when no organs or parts are readily discernible. It is true, the literature of the subject, English and foreign, is voluminous, but this does not imply extensive knowledge; a great deal of what has been penned is of that theoretical nature which is a cover for ignorance. The habits of this pest are exceedingly singular, and also obscure even yet, but I hope I can make some points clear which are at present cloudy to some. Condensing as much as possible, we note first, that it is occasionally spoken of as the Vine aphid, but is distinguished from the aphides proper by the three-jointed antennæ, though in its life history it nearly resembles that tribe, with certain differences that sever it and the other *Phylloxeras* from both the aphides and the coeci, or scale insects. With these it belongs to the Hemipterous order, and is perhaps—take it altogether—one of the most destructive insects of that group. Fortunately, only two species have occurred in Britain, the Vine *Phylloxera* and *P. Quereus*, which is not uncommon about the south during some seasons, and has been known here since 1834 at least. Several continental entomologists maintain that this, and several species beside, are migratory from trees to low-growing plants, and *vice versa*, and this may be the case, but *P. vastatrix* only transfers itself from the leaves to the roots of the Vine.

Assuredly *Phylloxera vastatrix* must have existed for a very long and unknown period in those North American countries which are its habitat, but during the reign of Victoria it has, to quote Mr. Buckton, "crossed the Atlantic, spread itself over the greater part of southern Europe, touched at Cape Colony in Africa, and brought its baneful influence to bear on the vineyards of Australia." Prof. Westwood received examples of it from English houses in 1863, and he named the species *Peritymbia vitisana*, in allusion to the tomb-like gall which encloses the mother insect. The leaf-haunting insects were the first to be observed, as was likely, afterwards the insidious feeders upon the Vine rootlets were detected. With us, at least, this enemy flourishes most in graperies and hot-houses, but in warmer climates it is very prolific on outdoor Vines. How dubious is its history appears from the warm debates whether the *Phylloxera* chiefly attacks strong or weak Vines, one party contending that it is the weakly or decayed which are selected, and the other maintaining that healthy Vines, as having the purest sap, are preferred by the insect.

When the leaves of the Vine are covered thickly with *Phylloxera*

galls (generally noticeable during May and June), they turn yellow or brown, the stocks become enfeebled, and there arises an unpleasant odour suggestive of decay. Still, the greater amount of harm is done by severe attacks upon the roots, the fibrils of which swell into knobs or tubercles, the vitality of the plant being endangered, while sometimes generation after generation succeeds before the insects are detected and dealt with. For, like the family of the aphides, generations to the number of five or six may follow each other during the summer season, apterous larvæ, or imperfect females, as they may be considered, producing young on a plan which has been compared to the budding of plants. Indeed Mr. Liechtenstein thinks this might go on, if the Vines can bear it, from year to year, without any winged forms intervening; he has noticed a succession for four seasons.

Ordinarily, however, on the best authorities, the order of life in the *Phylloxera* of the Vine is as follows:—Winged insects emerge in the course of the summer and autumn, but at first only of one sex. By the females are deposited egg-like bodies. The number each produces varies from one to eight, which are not eggs, but nymphs or pupæ, and these develop into true males and females, which continue the race, but eat nothing. Then the female gives birth to a roundish body, usually one, rarely two, which some naturalists regard as an egg, some as a pupa, and which is hidden under the bark of the Vine. This lies dormant through the winter, and hatches in the spring. The progeny of this is a creature which has been called the queen or foundress, and which has a certain resemblance in habit to the queen wasp. Her business is to form galls upon the leaves; each it is thought, makes but one, corresponding to the nest of the wasp, in which she becomes entombed, surrounded by her progeny. Or it may be she makes several, becoming a prisoner only in the last, otherwise there must be a succession of the flies, since galls appear at various stages through the summer; fifty and more have been counted upon one leaf. On opening a gall, we find hundreds, or even thousands, of minute yellow creatures, the juvenile *Phylloxeras*, but these do not complete their career upon the leaves. At some period during the summer they quit the galls, and dropping to the soil begin a subterranean life upon the roots of the Vine. For the sake of experiment, the attempt has been made to induce *Phylloxeras* from the roots to settle upon the leaves, but they decidedly object to be thus transferred. When arrived at the roots, the *Phylloxeras* increase, as remarked, after the manner of aphides, the apterous females depositing a number of partially developed individuals like themselves, probably from six to twenty, which pursue the like course later on. Out of these come the winged examples of summer or autumn, but all the while some *Phylloxeras* remain at the roots through the winter in a semi-torpid state, rousing about April, which is the time when chemical agents tell most effectually upon them. It is noticeable that the Vines of Europe do not seem, taken generally, to favour the growth of galls upon their leaves, for which reason the foundresses, or queens of the early summer, seek the roots at times, and insinuating themselves into the earth, make their galls where their wingless kinsfolk are feeding.

Several writers upon this insect have attributed its increase in some French districts to the known destruction of small birds, which has been going on in our sister country for many years past. A careful observer, the late Edward Newman, does not attach any importance to this. It is very unlikely that such birds seek out the *Phylloxeras* at the Vine rootlets, and they have never been seen to open the galls in order to eat their living contents. But it does seem as if those have some truth on their side who maintain that new varieties of the Grape are freest from attacks. Difficult as it is to deal with, the ravages of the insect may be checked, and it has even been effectually exterminated in some localities by perseverance in the methods which have repeatedly been pointed out in these columns. There is no question that flooding the Vine roots during winter is a capital plan, but one of limited application. Arsenate of copper, phenic acid, and other chemicals that have been recommended, have the objection of costliness, and also an amount of risk. Growers abroad have of late freely employed the sulpho-carbonate of potassium, which is not at all dangerous, and serves also the purpose of a manure.—ENTOMOLOGIST.

### RUXLEY LODGE, ESHER.

PROBABLY few gardeners find it an easy task to banish gardens and gardening from their minds when "out for a holiday," and if they are in the neighbourhood of a garden noted for something specially good, or within reasonable distance of a gardener famous as a good all-round cultivator, they feel that their duty requires that they should "call in" and "look round;" and I admit that I belong to that class of gardeners. But while passing through the "gate" of another garden, we should take care to close the gate of our own garden behind us, and, if possible, banish it from our minds. One of the chief objects in visiting gardens is, or should be, to store the mind with useful information, no matter

whether it be how to do a thing or how not to do it, and not for the purpose of making offensive comparisons at the expense of those who are so kind and courteous as to show us, or permit us to see, their produce.

Being a few days ago within a few miles of Ruxley Lodge, Esher, the residence of Lord Foley, I availed myself of an opportunity of visiting an old master and friend, Mr. John Miller, for many years head gardener at Worksop Manor and at Clumber House, Worksop, Notts, knowing from past experience that I should not only meet with a cordial and true gardener's welcome, but also see something in the gardens worth noting and remembering. In the Peach house *Grosse Mignonne* Peach and *Victoria Nectarine* are very good and highly coloured. The sub-laterals in the early vinery are allowed to extend themselves for the purpose of affording natural shade to the numerous and well-coloured bunches of *Black Hamburghs*, for it is well known that a strong sunlight quickly transforms "Black" *Hamburghs* into what are called "Red" *Hamburghs*, if some shade is not interposed between the fruit and the rays of the sun. The second vinery contains a good crop of useful sized bunches of *Hamburghs*, and the third vinery is planted chiefly with *Alicante*, *Lady Downe's*, and *Hamburghs*.

Roses are grown in large quantities and in the highest luxuriance. Those planted out in the greenhouses and trained on the roofs are *La France*, *Gloire de Dijon*, *Niphetos*, *Adam*, *Cloth of Gold*, *Solfaterre*, &c. The *Roses* in pots are young home-grown plants, and testify to the right kind of treatment received from Mr. Robert Miller, who acts as foreman for his father. *Strelitzia regina* was flowering freely in the greenhouse, and the plant at all times has a tropical and effective appearance. The *Azaleas* are well grown examples of the best varieties, and are numerous.

In the stove we saw a perfect jungle of form and colour. *Passion Flowers*, *Allamandas*, and *Bougainvilleas* vie with each other on the roof and hang down among the arching leaves of the *Palms* overhead; and around the sides are dense masses of *Caladiums*, *Begonia Rex*, *Pilea muscosa*, and *Asparagus plumosus*; and continuing to the floor are the trailing sprays of *Tradescantia zehrina* and *Panicum variegatum*. All formality is wisely dispensed with, but here and there a *Cycas revoluta* gives a bold effect, or a *Cocos Weddelliana* a graceful appearance.

The *Muscat* house contains a capital crop of fruit, and it is almost unnecessary to say that it is chiefly *Muscat of Alexandria*. Mr. Miller has frequently come out of pitched battles in the exhibition tent victorious, and he can do it still if he will but enter the arena again. As a cultivator of the *Fig*, few, if any, can surpass him; and the *Fig* house at Ruxley Lodge will shortly become as famous as did the *Fig* house at Worksop Manor. Nearly all the trees are at present in pots, and are bearing good crops of fruit, the principal varieties being *White Ischia*, *Negro Largo*, and *Brown Turkey*.

As empty houses at any time of the year are not desirable, the centre stages of two greenhouses at Ruxley Lodge—their customary occupants being outdoors—are filled with *Tomatoes*; but these, instead of being trained from the pots up sticks perpendicularly, are trained to a framework of hazel or any slightly pliable sticks, and carried from one side of the stage to the other, thus forming a curvilinear trelliswork, upon which the *Tomato* plants are trained. The varieties most in favour are *Hathaway's Excelsior* and *Trentham Fiddlebasket*.

The somewhat rare *Calliørpa purpurea* finds a home at Ruxley Lodge, where its racemes of greyish purple berries are much appreciated. This is a fitting companion to the *Rivinas*, *R. humilis* and *R. tinctoria*, and it is a pity they are not more frequently placed before the public. Both are easily grown, the *Rivina* especially so. A small house is devoted to *Gardenias*, and they luxuriate in it. The old hut ever fragrant and beautiful *Panacratium javanicum* is grown here in quantity; and amongst *Orchids* may be noted *Oncidium macranthum*, *Epidendrum vitellinum*, *Lycaste lanipes*, and *Zygopetalum Mackayi*.

Mr. Miller being the raiser of the excellent variety of *Melon* called *William Tillery*, one naturally expects to find that variety exceptionally good at Ruxley Lodge, nor are our expectations doomed to disappointment, for here we find such fruit of it as is rarely seen, good as it generally is. In the same large house devoted to *Melons* are some fine *Calanthes* that would do credit to the most accomplished *Orchid* grower; and *Eucharis grandiflora* var. *Bulli* (to me a new variety, and much smaller than *grandiflora*) is very numerous and appears to enjoy the treatment. In a pool of water are to be seen some plants of *Calla æthiopia* which appear to be quite at home and are flowering very freely. The effect produced is very ornamental and natural.

A portion of the flower garden is laid out in *Box* and in form of the *Prince of Wales's feathers*; and on the left of the mansion is a quantity of ornamental ironwork, forming pillars and festoons, and these in due time will be covered with ornamental climbing plants; and in the narrow borders at the base are artistically grouped such plants as *Pelargonium Rollisson's Unique*, large plants of double *Ivy-leaved Pelargoniums*, *Cannas*, *Liliums*, &c., all blending and harmonising in form, colour, and appropriateness. Several beds in the flower garden directly in front of the house are planted "carpet" fashion, and, considering the peculiar outline of the beds to be dealt with, Mr. Miller has evolved a singularly appropriate design; but it must be seen to be understood. In beds at some distance are herbaceous plants, which tend to lead the ideas from the more formal flower garden to its more natural surroundings; and close by are large pyramids—or rather, cones—of *Pelargoniums*, which give masses of colour without being flat or too formal in appearance, as "beds" usually are.

The kitchen gardens are large and well cropped with the fruit and vegetables required in a large establishment; and a good-sized orchard

supplies the usual orchard fruit. Here Mr. Miller, with his usual plan of keeping pace with the times, has been beheading some of the effete and worthless varieties, and had them grafted—Herefordshire fashion—with varieties of sterling merit. This is a step in the right direction, and were this done throughout the country we should soon cease to hear so much talk of the superiority of the American Apples over the English Apples.—J. U. S.

### MR. CYPHER'S PLANTS, AND HOW HE GROWS THEM.

ALL interested in plant culture as well as numerous visitors to the principal flower shows in the country are familiar with the name of Cypher, and, doubtless, a few remarks upon Mr. Cypher's famous *Queen's Road Nurseries*, Cheltenham, will be of interest to many of the readers of the *Journal of Horticulture*. On about one acre of ground there are arranged fifty plant houses, some of them being very commodious, and all well adapted for the purpose for which each is built. Naturally, the immense *Palms* and *Cycads* that form such admirable backgrounds to the noble groups of plants at various shows require much space, and those who may imagine that exhibiting must be profitable, would alter their opinion somewhat if they fully realised the amount of labour and other expenses constantly being expended upon the fine specimens at Cheltenham. Not only have the giants to be fed all the year round, but as these are liable to become shabby and comparatively worthless, a great number of young plants have to be gradually brought on to take their place. No exhibitor ought in any case to put all his "eggs in one basket," but duplicates of nearly everything is required in order to be certain to have one of them in a fresh condition at the right time. Mr. Cypher can compete successfully at one or more shows, and yet have numbers of attractive plants at home. They have no secrets, and if I failed to glean useful information it is my own fault.

*Ericas* always tell better than anything in a collection of well-grown stove and greenhouse plants, and of these they have a capital collection in various sizes. Some, notably a huge *Cavendishi*, not less than 7 feet through, have become too large to carry about, and will not be taken out many more times. Two sets of plants of both *E. Cavendishi* and *E. depressa* have to be grown, as they are only available every other year. Those to flower next season are now standing in the full sunshine, the pots only being covered with mats, and under this treatment they become thickly set with buds. The principal portion of the *Ericas* are grown in a light span-roofed house, and given abundance of dry air. In clear weather the lights can be drawn clean off the house, and in showery or dull weather returned and blocked open. Overpotting or careless watering are the principal causes of so many plants dying, and it is useless to attempt their culture in mixed plant houses.

The *Ixoras* are now very beautiful, and I fancy in better condition than I have formerly seen them. They are decidedly heat-loving plants, and require plenty of room and daylight. A good peaty soil suits them, and after the pots are well filled with roots liquid manure may be used safely and freely. Healthy plants break readily after being cut back, and, treated as just advised, no difficulty is experienced in setting abundance of buds. *Ixoras* are certainly very liable to be infested with mealy bug, but this is their principal failing, and why this beautiful class of plants are not more generally grown for affording cut flowers or for decorating plant stoves it is difficult to account for. Mr. Cypher will have a splendid plant of the finest of all *Ixoras*—viz., *Duffi*, for the August shows, and such good sorts as *Pilgrimi*, *coccinea*, *Williamsi*, *Westi*, and *Fraseri* in fine condition; *Westi* also being a promising novelty.

*Allamandas* are extensively grown, and principally in a low three-quarter span-roofed house. All are near the glass, for it is useless attempting to flower them in other but a very light position. They also require a strong heat, and will succeed in a house to which little or no air is admitted better than most flowering plants. The bulk of the *Allamandas* are started late in December, being previously well shortened back. When breaking strongly they are turned out of their pots, much of the exhausted soil picked away from the roots, and then repotted, using a strong loamy soil and pots a little larger than they were shaken out of. When the young growths have made good progress and hardened somewhat, they are cut back to the third or fourth joint, this causing each to push out three or four shoots, all of which soon develop flower spikes. Little or no training is done till near the time the plants are wanted for exhibition, quite a thicket of flowering shoots being then available. Both leaves and flowers soon face up to the light and appear to have long been trained to the globular or balloon-shape trellis used. *Allamandas* like plenty of water and liquid manure, and are benefited by a top-dressing of cow manure. The variety known as *Hendersoni* is the most generally grown, but Mr. Cypher also has beautiful examples of *nobilis*, this being the most difficult to grow.

*Dipladenias* are still more beautiful than *Allamandas*, and have more weight in a collection of plants. At Cheltenham they have several grand specimens each of *amabilis*, *Brearleyana*, *Williamsi*, and *profusa*, and a great number of medium-sized and small plants, all being in excellent health, and commencing to develop numerous strong flower spikes. They succeed well in the *Allamanda* house, but are by no means so easily cultivated. They are very fickle as to soil, loam usually proving fatal to them. Mr. Cypher uses good fibrous peat, charcoal, crocks, and sand. The pots are not large, are very freely drained, and the greatest care is taken not to overwater—too much water and a sour



compost being the principal cause of innumerable failures. The principal portion of the old wood is kept on the balloon-shaped trellises, the plants being well raised to the light, and the young growths trained up strings or allowed to grow freely over the roof trellising. This is necessary to induce free flowering, as it is quite possible to grow *Dipladenias* strongly and yet not flower them well. They are easily taken down and trained as required. Mealy bug is the greatest enemy to them, and hand-picking is the safest method of keeping them in check, any kind of insecticide or careless cleaning quickly injuring the foliage. The syringe should keep down red spider.

*Bougainvillea glabra* and *Clerodendron Balfourianum* are extensively grown, these by good management being available and very effective at both the early and late shows. The former thrives in a loamy compost, likes plenty of water and liquid manure, and may be rested or flowered in a cool house. Those for the early shows are rested in the autumn and started early in the new year, while those required in August or later are induced to grow strongly in the late autumn and winter months, and after being rested and lightly pruned these are re-started in May. *Clerodendrons* are given a peaty compost, are not rested in a cool house, this if tried sometimes proving fatal to them; but in other respects their treatment is very similar to that of the *Bougainvilleas*. *Pimeleas* of sorts are wonderfully fine, these being principally grown for the spring shows, and are now either just out back or breaking strongly. *Hedromas*, *Aphelaxis*, *Phoenocomas*, and *Staticee*, all indispensable to the exhibitor, are in excellent health, and include some of the best specimens in the country. Light and airy greenhouses are the positions for these, and they must have plenty of room and careful waterings.

*Anthuriums* are more within the reach of the generality of plant growers, and popular as they are, still more would grow them if it was known how little heat they really require. Mr. Cypher has a grand lot of plants growing in a comparatively cool house, and, if I remember rightly, a lean-to with a north aspect. Such a number of large freely flowered plants, not a poor variety among them, and including such grand sorts as *Schertzerianum*, *Cypheri*, *Wardi*, and some fine forms of *Andreanum*, is a sight not easily forgotten. All are rooting in a coarse *Orchid-like* compost, with a good surfacing of sphagnum, and with plenty of moisture at all times, and free syringings, very little else is needed. A little soot water appears to benefit them, and perhaps this is the safest fertiliser that can be given. At one time they had a grand lot of *Eucharis amazonica*, large specimens being frequently included in the groups of flowering plants. Now they can do nothing with them owing to the destructiveness of the *Eucharis* mite. The old stock was gradually burnt, and a new lot established in another part of the nursery, but these are also affected, and present a miserable appearance. Various remedies, or so-called remedies, have been tried, all to no purpose, and Mr. Cypher is beaten for once. Of *Pantrium* fragrans they have several wonderful specimens in 20-inch pots, and fully 7 feet through. They receive large quantities of water and liquid manure, and are grown constantly in a moderately high temperature. As many as thirty large flower spikes are developed on each in one season.

Fine-foliaged plants are not so numerous as flowering plants, the same giants doing duty at various places. A large span-roofed house is devoted solely to *Crotons*, and of these there are many very fine specimens. A high temperature is maintained early in the season, but more air is given when it is necessary to prepare the plants for the shows. They are shaded from bright sunshine, the blinds on each side of the house being run up or down according as the sun is on or off. Blinds are also freely used in a similar manner over the various plants previously alluded to, plenty of light being essential, but fierce sunshine is guarded against. The best *Crotons* for exhibition are *Queen Victoria*, *Reginus*, *Sunset*, *Thompsoni*, *Warreni*, *angustifolius*, *Williamsi*, *Montfortensis*, *Prince of Wales*, *majesticus*, *Countess* (in the way of but superior to *Johannis*), and *Neumanni*. For table decoration Mr. Cypher recommends *angustifolius*, *Countess*, *majesticus*, *inter-ruptus aureus*, *Aigburthensis*, and *elegans*.

*Orchids* are grown in very large numbers, and all appear to be in excellent condition. The *Cattleyas*, for which a span-roofed house 50 feet long, 24 feet wide, and 16 feet high was built a few years ago, were alone worth journeying a long way to see. Most of the valuable forms of *Mossia*, *Mendeli*, *Triana*, and *labiata* were flowering freely, as well as a few extra choice varieties of which Mr. Cypher holds the stock. *Laelias*, *Dendrobis*, *Masdevallias*, *Epidendrums*, *Cypripediums*, *Odontoglossums*, *Vandas*, in fact all the best *Orchids*, are well represented, and nowhere else can be seen healthier plants.

Although best known as an exhibitor of plants, Mr. Cypher attaches more value to the cut flower trade, and largely cultivates all the most serviceable classes of plants, both indoors and out. Orders are received from all parts of Great Britain and Ireland, more especially for wreaths, crosses, and bouquets. No one is ever refused admittance into these interesting nurseries, and many gardeners beside myself might with profit spend an hour or two with the Messrs. Cypher, the beautiful town of Cheltenham, too, being well worth a visit.—A VISITOR.

## HORTICULTURAL SHOWS. TAUNTON.

THE notes of our reporter of the plant and flower department of this Show having failed to reach in time for publication, we print what appears to be a very good description of that section from the *Somerset Gaze* te. The report of the fruit and vegetable departments is from one of our correspondents.

The twentieth annual Show of the Taunton Deane Horticultural and Floricultural Society was held on the 11th inst. in Vivary Park, Taunton, and notwithstanding the dryness of the season the exhibits in all departments were of extraordinary excellence. The interest manifested in the Exhibition by the inhabitants of the town and county showed no falling off, and throughout the day the park was visited by several thousand people. The Committee issued a request to the tradesmen of the town to decorate their establishments on the evening previous to the Show, and on Thursday morning most of the houses of business in the main streets exhibited flags, banners, and bunting in great variety. The bells of St. Mary's church rang out merry peals, and the Union Jack was hoisted on several of the public buildings. The Show, coming as it does in the wake of several important exhibitions in the west, is invariably favoured with high-class exhibits, and the Committee have of late years made their prize-list more attractive, with the result that the competition in all departments has grown exceedingly keen. For several years past a gratifying improvement in the quality of the exhibits has been noticeable, and in the opinion of those most competent to judge this year's Show was considerably in advance of any exhibition previously held under the auspices of the Society.

The whole of the arrangements were satisfactorily carried out by the Committee, while the secretarial duties were efficiently performed by Messrs. Maynard and Hammett, with the assistance of a staff of clerks.

The exhibits were staged in five large marquees. No. 1 tent, which was 160 feet long, contained a magnificent collection of plants and flowers. The first prize for twelve stove and greenhouse plants in flower (in pots) was awarded to Mr. B. W. Cleave of Crediton, who has figured largely in previous years' prize lists in this department, Mr. Cypher of Cheltenham, who is also a well-known prizewinner at West of England shows, being second. The plants of both exhibitors were a splendid lot. Mr. Cleave's collection comprised the following:—*Erica æmula*, *Lapageria rosea*, *Ixora Williamsi*, *Eucharis amsonica*, *Allamanda Hendersoni*, *Erica Eweriana* *superba*, *Allamanda nobilis*, *Clerodendron Balfourianum*, *Bougainvillea glabra*, *Ixora Prince of Orange*, *Erica obbata* *purpurea*, and *Ixora Fraseri*. Great credit is due to Mr. Lock, the gardener to Mr. Cleave, for the care and attention which he evidently bestows upon the plants. This year he has shown at Southampton and Weston-super-Mare with similar success. Mr. Cypher's collection included a number of good-sized and well-grown plants, admittedly a fine lot, but in the opinion of those most competent to judge they were hardly so fresh as Mr. Cleave's. There was an excellent *Phenocoma prolifera* *Barnesi*, and two good *Ericas*—*Thompsoni* and *Aitoniana*. In Class 2, for six stove and greenhouse plants, Mr. Cypher was awarded first with a very good collection, which included an *Erica Marnockiana* and a fine *Erica Irbyana*. The second prize went to Mrs. Pearce, a well-known exhibitor from Southampton. Mr. Cypher was first in Class 3 for eight fine foliaged and variegated plants (distinct varieties). The collection included a *Cycas circinalis*, *Cordyline indivisa*, *Kentia Fosteriana*, and a *Dasylium acrotrichum*. Mr. Cleave was second, his exhibits including a *Lantana borbonica* and a very fine *Croton Williamsi*, which were shown at Southampton and Weston with the flowering plants. The first prize for eight exotic Ferns (distinct varieties) was taken by Mr. Cleave with a grand lot of plants, with which he has gained similar honours wherever they have been shown. *Geraniums* were a very fine show, though some of the flowers were a little deficient in colour, owing, no doubt, to the hot weather. In this department Mr. Godding cleared the board of most of the prizes, taking in all no less than six firsts. Mr. Tidbury, another local exhibitor, was to the front in the class for *Geraniums*, variegated leaves, eight plants—a very meritorious lot. Two excellent plants were shown in the class for a newly introduced plant with ornamental foliage; the first prize went to Mr. Cypher, and the second to Mr. John Marshall. Mr. Cypher also took a first for *Orchids*.

Roses were a splendid show, and here the well-known growers, Messrs. Cooling & Sons of Bath, were to the front. Mr. J. Nation of Staplegrove was awarded first for *Dahlias* in three classes, his flowers being wonderfully fine. Mr. Smith of Bristol took two firsts for *Hollyhocks*. Some good *Verbenas* were shown, Mr. A. Guy-Evered taking first in both classes. Mr. Godding was successful in the class for *Gladioli*, twenty-four spikes. Competition in the class for cut flowers (twelve bunches distinct varieties) lay between the Earl of Cork and Mr. Jno. Marshall. The collection from Belmont included some extraordinary fine flowers, which reflected credit on the head gardener, Mr. Lucas. The Judges placed Mr. Marshall first in the class. Mr. Cypher was first in the class for *Orchids*, one of his plants being an excellent specimen of *Cattleya eldorado* *virginialis*. In this tent Messrs. Kelway & Son, seedsmen, Langport, exhibited, not for competition, forty-eight spikes of *Gladioli*, and they were awarded certificates of merit in respect to three—*Hilda*, a creamy white tinted with carmine; *Howard* *Maynard*, a bright scarlet; and *Ciris*, a white, shaded mauve and cream spot on the lower petal. The collection included some of the splendid specimens for which the Langport nurseries are noted. Mr. R. H. Poynter of Taunton exhibited, not for competition, a splendid collection of *Petunias* and other plants in good condition and of fine growth, which were certificated. Messrs. Kelway also showed two excellent specimens of *Gaillardia*, for one of which—*William Kelway*—they were awarded a certificate of merit.

The amateurs' exhibits, which were staged in the second marquee, were an excellent lot all round, the cut flowers being especially fine considering the difficulties which have attended their cultivation this year. It must have required an immense amount of care to bring the exhibits to the high standard of excellence. Mr. Cleave followed up his successes in the other department by clearing the board of the first prizes in five classes for stove and greenhouse plants and exotic and hardy Ferns, the second prizes going to Mrs. Pearce, Mr. John Marshall, Mr. W. G. Marshall, and Mr. F. W. Newton. Mr. W. G. Marshall was to the front in the class for *Japan Lilies* with four specimens that did credit to his head gardener, Mr. Thomas. Mr. Tottle was awarded first for *Fuchsias*, Mr. W. B. Hellard for *Begonias*, and Mr. John Marshall for *Gladioli*. There were some wonderfully fine *Geraniums* shown, and the first prizes were pretty evenly divided between Mr. Hellard and Mr. Tottle. Mr. W. G. Marshall took first in the classes for *Achimenes* and *Gloxinias*, and Mr. Manley was similarly honoured for *Petunias* and *Balsams*. Mr. Pope of Bath was to the fore in the classes for *German* and *French Asters*, and Mr. Nation took a first for *Dahlias*. The first prizes in the classes for *Verbenas* went to Mr. Guy Evered. Mr. C. L.



Collard of Wiveliscombe, who is a well-known exhibitor, gained the first prize for a *Lilium auratum*, and was similarly placed in two classes for Geraniums. Mr. Budd of Bath, who had to be content with second honours in the classes for Roses in the first tent, gained three firsts in this department with some splendid specimens. In the open classes for single specimen plants (of superior cultivation), Mr. Cleave added three firsts to his long list of honours at this Show. Mr. Tottle was awarded the first for greenhouse plants, and two firsts for Geraniums, while Mr. Godding took three firsts for Fuchsias and Geraniums. Mrs. J. R. Chard, Brunswick Nursery, Stoke Newington, took the whole of the firsts in the ladies' prizes (five in number)—viz., for dinner-table decoration, cut flowers arranged in a vase or any other ornamental stand (adapted for the dining or drawing-room), hand bouquet suitable for a concert or hall, wild flowers, ornamental device and bouquet. Miss Mabel Farrant, daughter of the Mayor of Taunton, was second in the first-mentioned class, the decoration being exceedingly tasteful, but rather deficient in quantity. Miss Mary Poynter was similarly placed in the classes for a hand bouquet and a bouquet of wild flowers. In the class for an ornamental device in wild flowers Miss Tazewell was placed second. Messrs. Robert Veitch & Son, Exeter, showed a miscellaneous collection not for competition, consisting of Orchids in variety, some of their very choice seedling Begonias (doubles and singles), the old-fashioned herbaceous plants, of which they grow an immense number owing to the great demand that is springing up for them on account of their being useful for cutting and for borders. They also showed cut flowers, their new variety of Cactus Dahlias which are so peculiar in formation and yet so fine for decoration: other Dahlias blooms, and a box of Gladioli, twenty-four varieties. Boxes of Carnation blooms suitable for horder or outdoor culture were included in the collection. There was also a box of double Zinnias, which were much admired. The whole collection was backed up by Japanese Maples, with their delicate Fern-like foliage, and altogether it may be said to have been a valuable attraction to the Show.

**FRUIT AND VEGETABLES.**—Two large tents were devoted to fruit and vegetables, the gardeners filling one and the cottagers the other. The drought has been badly felt in the Taunton district, very little rain having fallen this year, but in spite of this there was no appreciable falling off either in the quantity or quality of the products shown. Good prizes were offered for ten dishes of fruit, and for these the competition was close, there being three lots of nearly equal merit. Mr. H. W. Ward, gardener to the Earl of Radnor, Longford Castle, Salisbury, was placed first, his collection consisting of excellent Madresfield Court and fairly good Muscat of Alexandria Grapes, a fine Smooth Cayenne Pine, Hero of Lockinge Melon, Dr. Hogg Peaches, Pine Apple Nectarines, Black Tartarian Cherries, Moorpark Apricots, and poor Figs and Plums. The second prize was awarded to Mr. W. Pratt, Longleat, who had heavy bunches of Muscat of Alexandria and Hamburg Grapes and a good fruit of Charlotte Rothschild Pine, these dishes evidently being most weighty with the Judges. Mr. Iggulden, Marston House, Frome, had a good all-round collection, the Pine Apple spoiling his chance for a better prize. With four varieties Mr. W. Daffurn, Weston-super-Mare, was first, having large but not well coloured Madresfield Court Grapes, Scarlet Invincible Melon, Grosse Mignonne Peaches, and Newington Nectarine all in good condition. Mr. J. Lloyd, gardener to Vincent Stuckey, Esq., Langport, pressed very closely, and was awarded the second prize, Noblesse Peaches in this collection being very fine. Mr. Pratt was awarded the first prize for a Smooth Cayenne Pine Apple. The same exhibitor took the lead in the Black Hamburg class, having large but imperfectly coloured bunches. Mr. Iggulden was a good second, and Mr. H. W. Ward third. In the any other black class Mr. Ward was well first with good Madresfield Court, the second prize going to Mr. J. Lloyd for the same variety, and the third to Mr. Iggulden for small well-finished bunches of Gros Maroc. Mr. Pratt was first for Muscat of Alexandria; Mr. J. Loosemore, gardener to W. Cooper, Esq., being second; and Mr. Lloyd third, the colour being wanting in each instance. With any white variety Mr. Ward was awarded the first prize for only moderately good Buckland Sweetwater; Mr. Lloyd following, instead of being first as he ought, with Foster's Seedling; the third prize going to Mr. C. Cooper, gardener to C. L. Collard, Esq., for the same variety. Melons were not so plentiful as usual. Mr. H. W. Ward was first for a very good fruit of Hero of Lockinge, and Mr. W. M. Bryant second. Mr. W. Iggulden was first for Peaches, winning with a highly coloured dish of Crimson Galande; the second prize going to Mr. J. Newcombe, gardener to H. J. Gore-Langton, Esq. Mr. H. Ward took first prize in the class for Nectarines with a handsome dish of Pine Apple, Mr. Daffurn following with Elrue. Mr. R. Huxtable, gardener to F. W. Newton, Esq., was well first for Apricots; and Mr. J. Reed, gardener to F. C. Parsons, Esq., second. Mr. C. Lucas was first and Mr. Daffurn second for Pears; and the prizewinners with Plums were Messrs. W. Cavill, A. Crossman, and H. Hayward. Mr. Lloyd was first for Cherries, and Mr. S. Kidley, gardener to H. A. Helyar, Esq., second.

A silver cup, value five guineas, was offered for a collection of eight varieties of vegetables and six varieties of fruit, all to be grown in the open air. Several good lots were staged, but Mr. A. Crossman, gardener to J. Brutton, Esq., was well first. He had very fine Carter's Crimson Celery, white Spanish Onions, Jubilee Runner Beans, Ne Plus Ultra Peas, Vicar of Laleham Potatoes, Carter's Mammoth Cauliflower, Student Parsnips, and Carter's Altrincham Carrot; and of fruit, very fine dishes of Morello Cherries, Doyenné d'Été Pears, Rivers' Early Plums, Brown Turkey Figs, Apricots, and Early Rivers Peach. Mr. G. Garraway, Bath, was second, his collection including fine dishes of Queen of the West Vegetable Marrows, Ashleaf Potatoes, Incomparable Peas, Peaches, Plums, &c. The best ten dishes of vegetables were staged by W. Cavill, gardener to H. F. Manley, Esq., among these being good Model Cucumbers, Snowdrop Potato, and Champion Runner Beans. Mr. H. Moore was second with a good lot. Messrs. Webb & Sons offered prizes for six varieties of vegetables, the first prize being taken by Mr. Tilley, gardener to Col. Cotgrave, who had Webb's Sensation Tomatoes, New Intermediate Carrot, Leicester Red Celery, extra good. Mr. H. Moore was second. Several good collections of six dishes of Potatoes were shown, Mr. H. Moore leading with fine tubers of Reading Russet, Cosmopolitan, Vicar of Laleham, Prizetaker, Chancellor, and Prime Minister. Mr. W. Greedy was second. Messrs. J. Nation, H. Moore, W. Greedy, and A. Tucker were all successful in the other Potato classes. Celery was very good. Mr. C. Cooper being first with Incomparable

White. In the other vegetable classes the principal prizewinners were Messrs. H. Moore, A. Crossman, W. Cavill, J. Smith, G. Garraway, A. J. Evered, and C. Grant. Mr. J. Webber, gardener to G. F. Luttrell, Esq., was first for a brace of Cucumbers, and in a large class of Tomatoes Mr. Kidley was first with a very handsome dish of Sutton's Perfection.

#### WESTON-SUPER-MARE.—AUGUST 9TH.

The fifteenth annual Exhibition of this Society was in every respect a great success. A good all-round display was brought together and effectively arranged in four large tents. Mr. F. T. Perrett is the indefatigable and courteous Secretary, and, thanks to him as well as a good general Committee, everything passed off apparently to the satisfaction of all concerned.

Four good prizes ranging from £15 15s. to £3 3s. were offered for twelve stove and greenhouse plants, to include at least four foliage plants, and these attracted four competitors. After a very careful examination the Judges eventually awarded the first prize to Mr. G. Lock, gardener to B. W. Cleave, Esq., Crediton, his group taking forty points, and that staged by Mr. J. Cypher, Cheltenham, thirty-nine. So close in point of merit were these exhibits that many on-lookers were of opinion they should have been placed equal. Mr. Lock had an immense and very well grown *Lafania* horbonica and *Encephalartos villosus ampliatus*, *Croton Warreni*, and *Croton Williamsi* in fine condition, and very fresh and beautifully flowered specimens of *Ixora Prince of Orange*, *Erica amula*, *Erica Eweriana superba*, *Erica obobata purpurea*, *Lapageria rosea*, *Allamanda Hendersoni*, *Ixora Williamsi*, and *Eucbaris amazonica*, the last named having fully seventy flower spikes. Mr. Cypher staged good *Kentias*, a *Cycas*, and *Croton Queen Victoria*, while his best flowering plants were *Erica Marnockiana*, *Erica Iveryana*, *Bougainvillea glabra*, and *Erica Aitoniana*. Mr. E. Wills, gardener to Mrs. Pearce, Southampton, was third; and Mr. W. C. Drummond, Bath, fourth. The best six flowering plants were staged by Mr. J. Cypher, these consisting of *Clerodendron Balfourianum*, *Ixora regina*, *Erica Thomsoni*, *Allamanda nobilis*, *Statice profusa*, and *Allamanda grandiflora* in good condition. Mr. E. Wills was second, his group including a freely flowered *Statice profusa* and a good *Erica obobata purpurea*. Mr. G. Lock took the lead with four flowering plants, the second prize going to Mr. G. Holland, gardener to W. Ash, Esq. Mr. Lock was first for a single stove flowering plant, staging a good *Ixora Prince of Orange*, and in a corresponding class for greenhouse plants was first with *Erica Lindleyana*, Mr. Wills being second in both instances.

For six fine-foliaged plants, Mr. Lock was again first, having grand specimens of *Kentia Fosteriana*, *Kentia Belmoreana*, *Areca Intescens*, *Croton volutus* beautifully coloured, and *Croton Disraeli*; Mr. J. Cypher being a close second, and Mr. E. Wills third. In the class for a single fine-foliaged plant Mr. Lock was first with an immense *Gleichenia spluncæ*, measuring from 8 feet to 9 feet through, and Mr. E. Wills second with a good *Cycas revoluta*. Ferns were extensively and well shown. Mr. Lock was first for eight exotic varieties, these including fine specimens of *Marattia Cooperi*, *Davallia fijensis*, *Nephrolepis davallioides frcans*, and *Gleichenia Mendelli*. Mr. W. Lewis, gardener to J. E. Cole, Esq., Weston-super-Mare, was a creditable second, and Mr. W. Brooks, Weston-super-Mare, third. With six varieties, J. P. Cassell, Esq., Weston-super-Mare, was first, and the same position was taken by Mr. E. Wills for four varieties. Messrs. Lock, C. Holland, E. Wills, W. Lewis, W. C. Drummond, and J. P. Cassell, Esq., were also successful in the classes for *Adiantums* and hardy Ferns. *Coleuses* were not so good as usual. Mr. C. Holland was first for six plants, and Mr. W. Brooks second; and with four plants Mr. W. Brown was first, and Mr. H. Marshall, gardener to R. Cox, Esq., second.

Two beautiful lots of Orchids were staged. Mr. J. Cypher was well first with *Cattleya crispa superba*, *Aerides quinquevulnera*, *Cattleya Gaskelliana superba*, and *Saccolabium Blumei*, in fine condition. Mr. Wills had among others well-flowered plants of *Dendrobium formosum giganteum* and *Dendrobium Dearei*, and was second. A considerable number of *Zonal Pelargoniums* were staged, some of them being very well flowered. With six distinct varieties Mr. W. Lewis was first, Mr. W. Smith second, and Mr. W. Brooks third, and in the class for four double-flowering sorts, Mr. Lewis was again first, and Mr. W. Smith second. Begonias, on the whole, were poor. Mr. Brown and Mr. C. Holland were both successful with them. The best six *Gloxinias* were staged by Mr. C. Holland, Mr. G. Lock being a good second. Mr. R. Masson was first for Balsams, and Mr. W. Lewis second; while the prizewinners with *Petunias* were Messrs. C. Holland, W. Lewis, W. Brooks, and T. B. Vicary. Fuchsias were not of great merit. Mr. Brooks was the most successful exhibitor of these. The last named was also first for a new or rare plant, staging the curiously flowered *Aristolochia elegans*.

Cut flowers, as usual, were extensively and well shown, Roses being more abundant and good than might reasonably have been anticipated. The best twenty-four blooms of these were shown by Messrs. G. Cooling and Sons, Bath. Mr. J. Mattock, Oxford, was a good second, and Dr. S. P. Budd, Bath, third. The first prize for twelve varieties was awarded to Mr. T. Hobbs, Lower Easton, Bristol, who had good blooms. Messrs. Parker & Sons were a creditable second, and Mr. W. Smith, Bristol, third. Messrs. Cooling & Sons were well first for twelve Teas, having beautiful blooms of *Jean Pernet*, *Perle des Jardins*, *Innocente Pirola*, *Niphotos*, *Etoile de Lyon*, and *Alba Rosea*. Mr. J. Mattock followed, his best being *Grace Darling*, *Madame H. Jamain*, and *Madame de Watteville*, and Dr. Budd was third. Messrs. Parker & Sons also had a fine lot of Roses not for competition.

Dahlias were, in several instances, of great size, but not quite "up" in the eye. Mr. J. Nation had the best twenty-four blooms, these including *W. Rawlings*, *H. Austin*, *Mr. Glasscock*, *Herbert Turner*, *General Roberts*, *A. F. Barron*, and *Peacock*. Mr. G. Humphries, Chippenham, was a good second, and Mr. E. Harris third. With twelve varieties Mr. T. Hobbs was first, Mr. S. Tottle second, and Mr. F. Harris third. Mr. W. Brooks was first for twenty-four Gladioli, and Mr. S. Tottle second. Asters were plentiful and very fine. Mr. R. Richards, Stapleton, was first for quilled varieties, and Mr. W. J. Jones, Bath, second. Mr. W. J. Jones had the best twenty-four varieties, the second prize going to J. Cooling & Sons, and the third to Mr. G. Garraway, Bath. Mr. W. Iggulden, gardener to the Earl of Cork, Frome, was well first for twelve bunches of choice cut

flowers, and Mr. R. Richards second, the first prize for twenty-four varieties going to Mr. W. Brooks. Vases of cut flowers were well shown by Messrs. T. W. Gibson, Clifton, A. E. Thomas, and W. Brooks, and vases of fruit and flowers by Messrs. J. Attwell, gardener to J. B. Brann, Esq., and A. E. Thomas, the prizes going in the order named in each instance. Messrs. Perkins & Sons had the first prize for a magnificent bouquet, Mr. R. Richards being second.

Fruits of all kinds in season were well represented. The best collection of ten dishes was staged by Mr. Nash, gardener to the Duke of Beaufort, Badminton, who had the best Black Hamburg in the tent, and fairly good Muscat of Alexandria Grapes, a handsome Smooth Cayenne Pine Apple, Golden Gem Melon, fine Stirling Castle and Elruge Nectarines, Apricots, and a good dish of Black Tartarian Cherries. Mr. W. Iggulden was a close second, having good Hamburg and Muscat of Alexandria Grapes, fine Peaches and other good dishes, and a poor Pine. Mr. Pratt, gardener to the Marquis of Bath, Longleat, was third, his collection being most remarkable for the size of the Hamburg and Muscat Grapes and Smooth Cayenne Pine. Several good collections of four dishes were staged. Mr. J. Lloyd, gardener to Vincent Stuckey, Esq., Hill House, Langport, was placed first, having good Muscat of Alexandria Grapes, Highcross Hybrid Melon, Noblesse Peaches, and Oldenburgh Nectarines. The second prize was awarded to Mr. W. Daffurn, gardener to Mrs. Paterson, Weston-super-Mare, who had fine but scarcely ripe Madresfield Court Grapes and other good dishes, while Mr. Crossman, gardener to J. Brntton, Esq., Yeovil, was a creditable third. Mr. Pratt was first for large well berried Muscat of Alexandria Grapes, Mr. W. Cooper, Clifton, being second, and W. Coates, Esq., third, all the exhibits being poorly coloured. For any other white variety the first prize fell to Mr. J. Attwell, who had well coloured Blackland Sweetwater, the second going to Mr. J. Lloyd, who had good Foster's Seedling, and with the same variety Mr. Iggulden was third. The Black Hamburg class was a good one. Mr. Pratt was placed first for extra large but not well finished bunches; the second prize going to Mr. Iggulden, and the third to Mr. Nash, both having medium sized well finished bunches. In the any other black class Mr. Nash was first for beautifully finished Alicante, Mr. Lloyd being second with good Madresfield Court, and Mr. Iggulden third with Gros Maroc. Mr. G. Lock was first for a Pine Apple, and Mr. Pratt second, both having large fruit of Smooth Cayenne. Several Melons were shown, and, as usual, not many good ones were among them. For a green-fleshed sort Mr. J. Lloyd was first with a good High Cross Hybrid, Mr. J. Brntton being second with Golden Gem. A fine fruit of Lanefield Hybrid gained Mr. Iggulden the first prize for a scarlet-fleshed sort, Mr. C. Holland following with Scarlet Invincible. Mr. Nash was well first with a dish of Peaches, having fine fruit of Stirling Castle, Mr. Daffurn being second with Grosse Mignonne. Mr. Daffurn was first and Mr. Nash second for Nectarines, both having good Elruge. Mr. Daffurn was first for Pears with good Jargonelle, and for Apples with a handsome dish of Cooling's Beauty of Bath, Mr. T. Every being second with the same variety. The best Cherries, a fine dish of Black Tartarian were staged by Mr. Nash. Plums, culinary Apples, Gooseberries and Currants were also well shown.

Vegetables, taking into consideration the dryness of the season, were very good indeed. The best eight dishes were staged by Mr. T. Avery, Bathaston, who had good Hathaway's Excelsior Tomatoes, Grove White Celery, and Incomparable Peas. Mr. T. Tilley, gardener to Colonel Cotgrave, was second, and Mr. J. Hall, Shepton Mallet, third. Messrs. Webb & Sons offered prizes for six varieties, and with these Mr. G. Garraway was first, having fine dishes of Myatt's Ashleaf, Queen of the West Vegetable Marrows, Perfection Tomatoes, Incomparable Peas, and Webb's Red Globe Onion. Mr. T. Tilley was second, and Mr. J. Hall third. The prizes in a similar class were provided by Messrs. Sutton & Sons. Mr. Crossman was well first, having very fine Sutton's Reading Onions, Sulham Prize Pink Celery, Victory of Laleham Potatoes, Giant Runner Beans, and Intermediate Carrots. Mr. T. Tilley was again second, and Mr. J. Hall third. Mr. J. Lloyd was first for Cucumbers with Tender and True in good condition, Mr. J. Thorne being second, and Mr. J. Goddard had the best Tomatoes.

#### SUTTON AND CHEAM HORTICULTURAL SOCIETY.

The twenty-fourth annual Exhibition of this flourishing Society was held on August 10th in the very beautifully situated grounds of the Sutton Water Company, by the kind permission of the directors.

The Exhibition was a great success in every way. Specimen plants and groups were good, Fuchsias and Zonal Pelargoniums particularly so; Ferns and Selaginellas well represented; choice lots of cut flowers, of stove and greenhouse plants, Begonias, Cockscombs, Balsams well represented in their several classes. Amateurs and cottagers came out strongly in response to the numerous prizes offered, as many as forty-four classes being devoted to the latter division—a very laudable object and encouragement for the promoters and subscribers to the Society.

The principal class was the open one for twelve stove and greenhouse, in or out of flower. This brought three competitors, each showing an evenly balanced and good collection; being arranged on the grass down the centre of the tent were shown off to the best advantage. The first prize was awarded to Mr. W. King, gardener to Philip Crowley, Esq., Waddon House, Croydon, for a good collection of fresh and healthy specimens, amongst which was *Thrinax elegans*, *Areca lutescens*, *Asparagus plumosus*, *Anthurium Andreanum*, *Allamanda Hendersonii*, *Dipladenia amabilis* and *D. boliviensis*, *Bougainvillea glabra*, and *Impatiens Hawkeri*, the latter bright and showy. The second prize was awarded to Mr. Penfold, gardener to the Rev. Canon Bridges, Beddington, who had fine large plants of *Latania borbonica*, *Kentia Belmoreana*, *Alocasia Lowii*, *Croton Warreni*, an *Allamanda*, and *Cattleya Gaskelliana*, good. The third was awarded to Mr. Clark, foreman to Mr. James, Castle Nursery, Norwood, for larger plants of *Latania borbonica*, *Macrozamia Densouii*, *Cycas revoluta*, and *Erica æmula*, but one or two of the flowering plants were past their best. The prize for the best single specimen was awarded to Mr. King for a fine plant of *Phoenix sylvestris*; Mr. G. Smith, gardener to G. Orme, Esq., Sutton, taking second for *Chamærops excelsa*. In the smaller classes for stove and greenhouse plants, Mr. C. Lane, gardener to E. Colles, Esq., Cheam, Mr. G. Smith, and Mr. Broughton, gardener to W. F. Hughes, Esq., Sutton, were successful with smaller plants of great promise. In the open class for eight ornamental foliage Mr. Penfold was first with a nice even lot, with Mr. G. Smith second.

The class for the best-arranged group was well contested, Mr. Clark, foreman to Mr. James, showing a very tastefully arranged assortment of elegant Palms, with a groundwork of Orchids and Ferns; Mr. Buss, gardener to A. W. Aston, Esq., Epsom, taking second with bright young plants of Crotons and Dracenas, with Begonias, &c., intermixed, but the background was defective; J. Flemwell, Esq., was third with a heavier lot. Mr. Penfold was first in the class for six Ferns with well-grown plants, with Mr. G. Smith second. The prizes for Selaginellas brought two good lots, Mr. Rodbourne, gardener to Baroness Heath, Coombe House, Croydon, showing a splendid lot of fresh pans in the best condition; Mr. W. King was second with good plants, consisting of more of the hardwooded varieties, but they were somewhat past their best. It is not often Fuchsias are seen in better condition than was represented here by the two collections. They were tall, rather narrow pyramids, but fresh and well flowered, especially the first prize plants, which came from Mr. Broughton; the second from Mr. C. Lane. Zonal Pelargoniums were well trained and full of flower, the first prize going to Mr. Lane, the second Mr. Smith, third Mr. Broughton. The Begonias were represented by large plants, and some of them good varieties, but many were sparsely flowered. The first in the class for eight was taken by Mr. Buss with strong plants of good quality; the second Mr. Keel, gardener to W. Petty, Esq.; third Mr. Penfold. The first for Cockscombs went to Mr. C. Gibson, Marden Park, for dwarf plants with good heads fully developed, the second to Mr. Lane for younger plants, the third Mr. Smith. Cut Roses were not large, but fresh, Mr. Gibson taking first in the class for twenty-four varieties, were very choice and attractive, Mr. Penfold taking first for splendid plants, which included many varieties of Orchid and stove and greenhouse flowers, Mr. Gibson second. In the class for eighteen varieties Mr. Broughton was first, Mr. Lane second. For twelve cut herbaceous Mr. Carter, gardener to Alderman Evans, Ewell, was first with an attractive lot, Mr. Smith second. The first prize for a hand bouquet was awarded to Mr. Hogg and the second to Miss A. E. King, and for two gentlemen's button-holes and one ladies' spray Mr. Carter was first with Tuberoses, *Oncidium flexuosum*, and *Tabernaemontanas*; second Miss King.

Fruits and vegetables were fully represented in their several classes, but many of the collections were below the average, especially in the hardy fruits and vegetables, which is not at all surprising in this exceptionally dry season. Grapes—Mr. G. Potts, gardener to the Rev. W. Winlaw, Marden, was first in the class for a dish of Black Hamburgs; Mr. Blurton, gardener to H. Cosmo Bonsor, Esq., M.P., second with well finished bunches; Mr. Astridge, gardener to R. J. Nevan, Esq., third. For any other black variety Mr. Blurton was first with Madresfield Court, Mr. Astridge second with the same variety. In the Muscat class Mr. Blurton was again first, Mr. Smith second. For any other white Grape Mr. Blurton was first with Buckland Sweetwater, Mr. Smith second. Peaches, Nectarines, and Apricots were represented, and the chief prizes taken by Messrs. Gibson, Astridge, and Penfold. For a green-flesh Melon Mr. Penfold was first with Hero of Lockinge; Mr. D. Harris, gardener to W. J. Barker, Esq., with William Tillery. In the scarlet flesh class, Mr. Harris was first with Benham Favourite, small, but of good flesh and excellent flavour; Mr. Carter second; and Mr. Blurton third. Mr. Jones, gardener to R. Brougham, Esq., was the principal exhibitor of Apples and Pears, and took the leading prizes, showing Lord Suffield in the class for kitchen Apples, and Red Astrachan for dessert, and Citron des Carmes as a dessert Pear. The special prize offered by Messrs. Sutton & Sons for a collection of six kinds of vegetables brought strong competition, the first prize going to Mr. G. Cnmmmins for a good selection, the second to Mr. G. Woodman, Model Farm, Dulwich, and the third to Mr. Osman, S. M. D. Schools. The other classes for Potatoes and other vegetables were well contested, and in some cases good dishes were shown. The amateurs and cottagers came out strongly in their several divisions, the latter having a tent devoted to their exhibits, over a hundred bouquets and baskets of wild flowers being shown by children in the various classes. There were some good groups of miscellaneous exhibits not for competition (which I have omitted) and ought to be mentioned. Mr. Bains, gardener to Sir Trevor Lawrence, Bart., M.P., exhibited a choice group of Orchids, Anthuriums, Lemoine's new hybrid *Gladiolus*, &c.; Mr. Cnmmmins, a beautiful arranged group of Orchids Palms, Crotons, and Lilliums, which added much to the attractions of the Show; Messrs. J. Laing & Co., Forest Hill, groups of Palms, Caladiums, Orchids, and Begonias; Mr. J. R. Box, Croydon, a similar assortment; Mr. E. Morse, Epsom, large Palms, Ferns, Tuberoses, new hybrid Cannas, &c.; Messrs. Cheales & Sons, Crawley, box of cut Dahlias, &c.; Mrs. Dartnall Sutton, an attractive stand of Ferns, Grasses, &c., arranged in virgin cork; Mr. Wiggins, gardener to W. Clay, Esq., Kingston-on-Thames, a basket of their new tricolor Pelargonium Harbour Light, which was bright and attractive.

The arrangements of the Exhibition were well carried out by an energetic Committee, of which J. Flemwell, Esq., is an able Chairman, and Mr. W. R. Church the Secretary, whose devotion to the services of the Society was recognized in a substantial manner at the midday luncheon to the Judges, by being presented at the hands of the Chairman, on behalf of himself and fellow members, with a complete set of twenty-four volumes of Thackeray's works. This was acknowledged in a very able and characteristic speech. The Judges were Mr. Peed, Norwood; Mr. Appleby, Dorking; Mr. Omant, Epsom; Mr. Hogg, Sutton.—C. O.

PLANTS IN ROOMS.—To ascertain whether the air of the greenhouse had more carbonic acid by night than by day, I gathered two specimens of air in different parts of the house at 2 P.M., April 17th. These gave 1.40 and 1.38 parts of carbonic acid in 10,000, or an average of 1.39 parts, showing that the night air contained more carbonic acid than did the air of day. Now, if a room in which were more than 6000 plants, while containing more carbonic acid by night than by day, contains less carbonic acid than any sleeping-room, we may safely conclude that one or two dozen plants in a room will not exhale enough carbonic acid by night to injure the sleepers. Flowers, by their agreeable odour and delicate perfume, impart an air of cheerfulness to the sick chamber, which will assist in the recovery from lingering disease.—R. C. KEDZIE.





## FRUIT FORCING.

**PEACHES AND NECTARINES.**—*Planting or Lifting Trees for Early Forcing.*—If new houses have to be planted, and fruit is wanted next season at an early period, the trees should be planted as soon in the late summer or early autumn as the growth is perfected, the wood and foliage being ripe, and the buds plumped. The most suitable trees are those that have been trained three or four years to walls, and have been lifted annually or biennially. Those intended for moving to houses to be started early ought now, if there is any tendency to a late growth, or any doubt as to the maturity of the wood and buds, to have the soil taken out as deeply as the roots one-third the distance from the stem that the trees extend, and the trench so made should remain open for a fortnight or three weeks, when it may be filled again, care being taken not to allow the trees to want for water whilst the trench is open; all that is necessary, however, is to give no more than to prevent flagging. This will effectually check the growth and insure its ripening, whilst it will materially assist lifting with a ball or a mass of fibrous roots. The trees for early forcing should be planted by the end of September, and lifting early forced trees should be commenced as soon as the foliage gives indications of falling. It will not matter about a few sappy laterals; their softness will tend to the manufacture of roots. Soil should be obtained in readiness, so that work of this kind can be performed with the utmost promptness and dispatch. Clean drainage, too, in different sizes should be provided. The soil may consist of any good loam, preferably strong and calcareous, nothing being lacking in the top 3 or 4 inches of an old pasture overlying limestone or chalk, and if intermingled with flints all the better. Such will grow Peaches to perfection without any admixture. If the loam be at all light add a sixth of finely divided marly clay. Any deficiency of calcareous matter may be overcome by an addition of chalk to sandy soil, and of lime rubbish to heavy soil. New borders must have efficient drainage, the bottom of the border being concreted if the strata beneath be unfavourable, or better laid with bricks on flat run with cement, the border being further enclosed with walls so as to confine the roots. A width of border one-third the width of the trellis will be sufficient in the first instance. It is essential that the drains have a proper fall and outlet, rubble being placed over them a foot thick, the roughest at the bottom and the finest at the top, and if covered with a layer 2 or 3 inches thick of old mortar rubbish the drainage may be considered sound for an indefinite period. Twenty-four inches depth of border is ample. The best varieties for early forcing are Alexander, Waterloo, a high coloured and taking fruit of high quality, but unfortunately a clingstone, Early Beatrice, and Early Rivers. The finest, however, from a remunerative point of view are Hal's Early, Early Alfred, Royal George, or its fine form Stirling Castle, and Grosse Mignonne, which are free setters, and good alike in looks and quality. Of Nectarines Lord Napier is superb, Hunt's Tawny, though small, colours finely, and the quality unsurpassed in early Nectarines, Elruge being in every respect excellent.

**MELONS.**—Place out the last plants. Preserve the leading shoot until it reaches two-thirds across the trellis, then pinch out its point, rubbing off the laterals up to the trellis, and then every alternate one on opposite sides of the primary. Maintain a temperature of 65° to 70° at night, and 70° to 75° by day, 80° to 85° from sun heat, closing early so as to run up to 90° or 95°. Stopping the laterals should not be practised unless the plants are weak and they do not show fruit at the second or third joint. Weakly plants should have the first shows of fruit removed, relying on the sub-laterals. Early ventilation with plenty of light are the essentials of a thoroughly solidified growth.

The last plants in pits and frames are swelling freely. Earth up the roots if necessary, but late plants on dung beds do not require a large amount of soil. Close early, affording the needful supplies of water at that time, keeping laterals well in hand, not allowing them to interfere in any way with the principal leaves. If the weather be dull afford good linings and admit a little air, as nothing is so fatal to quality in Melons as a close atmosphere. Sprinkling should only be practised on fine afternoons. If black aphides attack the plants fumigate on two or three consecutive evenings moderately. Examine frequently for canker, and promptly apply quicklime to the affected parts. Gradually withhold water at the roots and moisture in the atmosphere from plants ripening fruit, and if a little extra heat is afforded by means of linings so as to admit of a free circulation of air, the quality of the fruit will be enhanced considerably.

**CUCUMBERS.**—Encourage the plants for autumn fruiting to make a strong growth by adding fresh soil from time to time, affording plenty but not overmuch water at the roots, with a moist genial condition of the atmosphere by syringing at closing time, and damping available surfaces occasionally. Sufficient fire heat must be employed to prevent the temperature falling below 65° at night, and to maintain it at 70° to 75° by day. Old plants should have the exhausted growths cut out, and others where likely to be crowded thinned, so as to admit light and air, securing a sturdy solidified growth and a succession of bearing wood.

The syringe should be regularly employed about 3 P.M., and if mildew appear dust with flowers of sulphur in the evening whilst the foliage is damp, maintaining a somewhat freely ventilated atmosphere. Black aphides are unusually troublesome. Those and green aphides sub-umb to repeated fumigation with tobacco paper, taking care to have the foliage dry, to deliver the smoke cool, and to ventilate freely the following day.

## PLANT HOUSES.

**Crotons.**—Where small plants are required in large numbers for decoration during the autumn and winter in from 2 to 4-inch pots very few plants surpass Crotons, either for beauty or lasting properties. To have them in good condition they must be highly coloured or their effectiveness is lost. Well coloured side branches should be taken off at once and rooted in the pots in which they are to be used. Cuttings of a suitable nature should be plentiful on plants from which the heads were taken and rooted some time ago. We invariably find the smallest cuttings with three or four well developed leaves very useful in thumb pots. It is useless to insert cuttings that are not fairly well coloured, for they will not improve after the end of September. As soon as these small plants are rooted gradually expose them to full light and sunshine close to the glass, and if the weather prove bright for a few weeks the colour of their foliage will be highly developed. The Crotons intended for autumn and winter decoration should by now be placed in their largest pots; in fact, only the best rooted should remain to be potted, and these must be attended to at once. All our plants are well established, and will soon have grown as large as they are desired, while the beautiful markings of a few of the young leaves near the top only need developing. Where the plants have been grown close to the glass they should be examined for fear red spider has attacked the young leaves. This pest, if in existence, will quickly spoil the appearance of the plants. The quickest and easiest means of destroying the pest is to dip the plants in a solution of softsoap and water, one ounce of the former to a gallon of the latter, to which should be added a handful of sulphur. This may be left on the plants two or three days, and then thoroughly washed off with clean water, and the syringe used twice or three times daily.

**Panicum variegatum.**—A good stock of this useful decorative plant should now be prepared by inserting cuttings thickly in 2 and 3-inch pots. After insertion a good watering should be given and the pots stood in the propagating frame and shaded until they are rooted. Grow the plants afterwards under moist, shady, warm conditions until they are well furnished, when slightly cooler treatment may be given them.

**Tradescantia.**—Large numbers of the variegated forms should be prepared by inserting about five cuttings in each 2-inch pot. These will root freely enough on a high shelf or any other position in heat if shaded for a few days from the sun. A few boxes may also be filled so that the plants can be lifted out for various purposes when vases and baskets have to be made up with a variety of small plants.

**Coleus.**—These are also useful in small pots, but the cuttings should be inserted singly, and distinct bright colours selected. A good dark form will be found most useful for dinner table decoration if the plants are dwarf and well furnished with large leaves at the base. For this purpose the tops of shoots that have grown strongly should be selected. Coleuses soon draw up too tall for a variety of purposes even when confined in small pots, and therefore some should be rooted at intervals of every three weeks during the winter. Although they do not last so long as Crotons they are distinct from those plants, and their highly attractive appearance during the winter renders them invaluable.

**Fittonias.**—These are highly ornamental in appearance when dotted amongst small Ferns and other suitable plants near the edge of large baskets or vases that have to be regularly furnished. The plants required first should be rooted singly in 2-inch pots, and quantities of others in boxes and pans for lifting out when required during the winter. If they can be used in small pots two or three weeks is ample to establish them, and they can be potted from the boxes in batches as required.

**Pertolonias.**—This is a good time to root a number of these as well as Sonerilas. Young plants pass the winter with greater certainty than those that have been growing luxuriantly the whole of the summer. The established plants need not be destroyed for this purpose, for cuttings near the base of the former will be found, and young growing shoots from amongst the latter should be selected without destroying the appearance of those now doing duty in the stove. These cuttings should be inserted in light sandy soil and kept close, moist, and shaded until thoroughly established; in fact they will winter better in the propagating house than the stove, where more airy conditions will presently be maintained.

**Polystichum proliferum.**—Although this is a hardy variety, it is perhaps the most useful Fern that can be grown in small pots or pans for furnishing purposes. In 3 and 4-inch pans with the surface covered with Selaginella so as to hide the pans, few, if any, small plants are more handsome for forming rows on the dinner table. For this purpose two or three small plants should be inserted together, for by this method suitable plants are produced in less time, and have a better furnished and more ornamental appearance. Those in pots may be potted singly. A large stock is easily raised by growing a plant or two, and then pegging down the fronds from time to time. During the summer these plants do well in cold but shady frames, and in winter should have gentle warmth, or they do not retain their beautiful fresh appearance. Gentle heat keeps them growing slowly, while cool treatment



matures their fronds, which assume too brown a hue to be highly ornamental. Strong heat in any stages should be avoided, or the plants soon become a prey to thrips.

*Selaginella Kraussiana*.—This is better known perhaps as *S. denticulata*, and should be prepared in quantity in pots and shallow pans for furnishing purposes during the winter. Nothing is gained by potting large bunches; the pots or pans should be filled with light sandy soil in which a good quantity of leaf soil has been incorporated. Dibble the young growing ends closely together all over the surface. These should be frequently syringed, and if given gentle heat and a shady position will cover the surface thickly, ready for use. When well furnished place the pots and pans in a cool structure.

#### THE FLOWER GARDEN AND PLEASURE GROUND.

**Propagating Stock Plants.**—Cuttings of Zonal Pelargoniums are very scarce, and if any attempt is made to propagate the usual number at this time of year the beds, in many instances, will be permanently disfigured. If a number of cuttings can be procured without leaving any blanks in the beds all well and good, otherwise it will be better to eventually lift all the old plants and store for spring propagation. Many have a prejudice against spring-struck Pelargoniums, and before the introduction of the freer flowering sorts the autumn-struck plants were unquestionably the best. We find the spring-struck flowering sorts quite equal the autumn-struck in everything but size, while the young or spring-struck variegated varieties usually surpass the older ones. Any of the green-leaved sorts may be struck and wintered in shallow boxes, but the more delicate variegated or golden-leaved varieties are more easily wintered rather thickly in well drained 5-inch or 6-inch pots. The boxes also ought to be well drained, a saturated soil and damp being fatal to so many plants. Any good loamy gritty soil is suitable, and the cuttings may be stood in the open exposed to the full sunshine till cold rainy weather sets in. A still greater difficulty will be experienced in obtaining good Verbena cuttings. Even if the hard and wiry young shoots that may be taken off do strike root they rarely develop into healthy plants. If there are any spare plants in the kitchen garden borders these should be freely cut back, and if mulched and kept supplied with water, varied with liquid manure, plenty of soft clean cuttings ought to result. At the present time such cuttings would, if properly shaded, root freely in a close frame, and might be boxed or potted off later on. It is nearer, or in September, when suitable cuttings are procured; these ought to be struck in a frame stood over a mild or nearly exhausted hotbed. Four or five cuttings may be placed round the sides of 5-inch pots, a good loamy soil being used, and they can be wintered in these pots. Alternantheras strike readily enough in a gentle heat or a close frame, but we find well-established plants the easiest to winter, and they yield a great number of cuttings in the spring. Our stock plants are potted from the frames soon after the flower beds have been filled. They grow to a good size, and are useful for decorating. Those who have no surplus plants to take up should strike a quantity of cuttings at the present time in preference to depending upon the stock of frost-touched plants that may be lifted in the autumn. Well drained 4-inch or 5-inch pots are suitable, and these should be filled with light or rather peaty compost. About ten good cuttings may go into each pot, and they will strike quickly in a close warm frame. If there are insufficient Coleuses left in pots, cuttings of these also ought to be struck at once, in much the same way as Alternantheras, fewer cuttings, however, being placed in each pot. Our surplus plants are given a shift, and these give us abundance of cuttings in the spring. In the case of Heliotropes the best course to pursue is to shift a quantity of young spring-struck plants into 6-inch pots. These are useful in the autumn for conservatory and greenhouse decoration, and yield a quantity of both flowers and cuttings in the spring. If it is necessary to strike a number of cuttings for stock purposes, choose young growing shoots, and strike these in pots under a close frame. Petunias and Ageratums are quite as difficult to propagate in the autumn, but if the young shoots are duly made into cuttings, dibbled in rather thickly into pots of fine fairly good soil, and kept close and shaded, many of them may strike. The young shoots of Lobelias root quickly in a close frame. Put in plenty of them, as they will not grow to a great size. Seedlings of a good strain are almost equal to named sorts from cuttings, and the seed may be sown now or in the spring. The seed must either be sown very thinly, or the seedlings be pricked off rather thickly when large enough to handle, otherwise they are liable to damp off wholesale. The small side shoots of Centaureas, if slipped off, trimmed, and placed in thumb pots, will usually strike freely in a close handlight or frame. Plenty of sand should be added to the soil, and when rooted the plants should receive a small shift. Calceolarias, Violas, and Pansies may be put in as late as October, no class of plants being more easily struck and wintered than these.

**Late-budded Roses.**—A great many buds have been inserted into the stocks only to perish in a few hours. Experts, as well as the more inexperienced, have failed to successfully bud even one-fifth of the stocks. It is all owing to the long spell of intensely hot and dry weather, the almost sapless shoots failing to sustain the buds in a parched atmosphere. Those who have put off the operation in the hope of more suitable weather being experienced are in the best position. They may well delay budding still longer. Buds inserted as late as September do not burst into growth the same season, but they become united to the stock, and start strongly the following spring. These dormant buds are hardier than young shoots.

## THE BEE-KEEPER.

### PRACTICAL BEE-KEEPING.—No. 15.

If the honey flow of the year commences on June 7th, and stocks are not ready to yield a swarm on or before May 15th, the bee-keeper will at once consider whether it will be to his benefit to lose the early part of the honey flow, to entirely prevent swarming, or to take half a swarm from each stock. If there is no honey coming in during May, and under the circumstances mentioned in a preceding article he decides to adopt the modified increase method in preference to the two extreme systems, he will gain a very large measure of success with practically no risk of failure. In the swarming system unless the swarms come forth naturally there is certainly some risk to stocks manipulated by those without sufficient experience to judge how large a swarm a given stock can spare. Again, in the non-swarming system there is, unless the greatest care is taken in following out the directions given on the subject, a risk of a swarm issuing at an unforeseen time and being lost. But when half a swarm or less is taken from a stock it is hardly possible to materially damage the stock without very gross carelessness, and yet the swarming desire being to some extent gratified there is little probability if ordinary care is exercised of a swarm issuing during that season. Again, two stocks and a swarm are ready to take advantage of the honey flow instead of two stocks only; there is at least one young queen gained, and the bees have by judicious feeding been kept in good heart and strength at a time when natural stores are not sufficiently abundant to stimulate the queen to sufficient exertion.

If in May there is no honey to be gathered in the fields nothing will repay the bee-keeper better than to utilise this period for increase—either full or proportionate—especially if there are spare combs to use when the great flow commences. Those who are able to take artificial swarms will have no difficulty in taking half a swarm from their stocks. In the middle of a fine day all the bees and queen must be taken from a stock, which may for the sake of lucidity be called A; these bees form the swarm, and must be placed in a hive which must stand on the exact spot occupied formerly by A: A has thus given up all its brood and stores. It is intended then to take from another stock, say B, sufficient bees to hatch out the brood in A, and to rear a queen unless the bee-keeper has one ready to insert: A must now be placed on the exact spot occupied by B, and B must be moved some distance away from its old location. The flying bees of B will go to A, recognising no change in the outward appearance of their hive at least, and will stay and rear the brood and form a strong colony in a very short time, while sufficient bees (many of them too young to leave the hive) will remain in B to hatch out its brood and to attend to the eggs which the queen will continue to deposit. If, however, after a few hours B seems to be depopulated too much, by bringing it some feet nearer to the old stand a few more stray bees which have not yet settled in A will be gained. In practice, however, this difficulty is rarely experienced, provided that the whole manipulation is performed in the middle of a fine warm day, or some other time when the great majority of the bees are on the wing. The outward appearance of the hive in which the bees taken from A are placed should be as similar as possible to the stock, and A itself should be made most nearly to resemble B, while less care may be

taken of B, because we do not desire more than half of the bees to find their way back to the stock to which they really belong. These stocks and the swarms thus taken will in a few days be ready for supering. The swarm will be a very strong one, and the stocks will soon recover their strength through the brood which will be hatching out in large quantities every day and hour.

The winter preparation of stocks managed upon this system should be identical with that laid down in a former article for the management of stocks from which it is intended to take a full swarm. Those who will give this plan a trial will find it successful when the other systems fail; those who have not had much experience in taking swarms artificially, and especially those who have tried to take them and failed, should try this method, which is the most simple and least dangerous system extant for taking swarms without loss. In many districts, it is true, it would be most injudicious not to take a full swarm; in these localities it would be sheer folly to take any increase at all, but under certain circumstances the modified increase system may, as I pointed out a few weeks ago and now maintain, be carried to a most successful issue, and enable many bee-keepers to manage their bees more profitably, and in not a few instances more pleasantly than heretofore they have been able to do. Not the least advantage attending this plan is that in the second week in May, if stocks which were intended to yield a full swarm are not strong enough, the modified method may be adopted, and the adoption of the non-swarming system which would have otherwise been forced upon the bee-keeper is avoided.

Each one who has followed me in this long discussion will now be able to grasp the main principles of each method, and if the salient points are remembered no difficulty will be experienced in following the directions which shall be given in future papers for carrying any or all of these three systems to a successful issue.—FELIX.

[The above should have been inserted before No. 16, but was by accident omitted.]

#### TRADE CATALOGUES RECEIVED.

James Veitch & Sons, King's Road, Chelsea.—*Catalogue of Hyacinths and other Bulbs, 1887 (illustrated).*

J. Carter & Co., 237 and 238, High Holborn.—*List of choice picked Bulbs, 1887.*

T. Laxton, Bedford.—*List of New Strawberries.*

Wm. Paul & Son, Waltham Cross, Herts.—*Catalogue of Bulbs and Winter Flowers.*

B. S. Williams, Upper Holloway.—*Catalogue of Bulbs, Fruit Trees, Roses, &c.*

James Cocker & Sons, Aberdeen.—*Catalogue of Hyacinths and other Bulbs.*



All correspondence should be directed either to "THE EDITOR" or to "THE PUBLISHER." Letters addressed to Dr. Hogg or members of the staff often remain unopened unavoidably. We request that no one will write privately to any of our correspondents, as doing so subjects them to unjustifiable trouble and expense.

Correspondents should not mix up on the same sheet questions relating to Gardening and those on Bee subjects, and should never send more than two or three questions at once. All articles intended for insertion should be written on one side of the paper only. We cannot reply to questions through the post, and we do not undertake to return rejected communications.

**LATE INQUIRIES.**—It is necessary to again remind correspondents that letters arriving on WEDNESDAY MORNING cannot be answered in the "next issue," which is then far advanced for press.

**Shrivelled Nectarines (T. A. T.).**—The fruits reach us just as we are going to press, and cannot be attended to this week.

**Walking Stick (G. T.).**—We have had many things sent to us to be named from time to time, but the line seems hitherto to have been drawn at walking sticks. We think the one you have sent was made from an Oak sapling cut when green, hence the shrinkage of the bark and the lightness.

**Insects (H. P.).**—We are not able to give the name of the insect that causes "blindness" in Broccoli and other plants. If any of our readers can do so we will readily publish the information. The name of the Pear tree blister moth is *Tinea Clerckella*, which was referred to, and preventive measures suggested, on page 128 last week.

**Select Daffodils for Pots (J. W.).**—You do not say whether you only require the dwarf varieties, so we have named a few of the large-growing sorts as well. One of the best for pots is the Hoop Petticoat Narcissus, *Corbularia (Bulbocodium)*, which has an excellent appearance when several bulbs are placed together in a 60 or 48-size pot. The following are also distinct and handsome varieties: *Horsefieldi*, *cernuus*, *pallidus præcox*, *incomparabilis* Sir Watkin, *Macleai*, *odoratus*, *Burbidgei*, *poeticus ornatus*, *poeticus recurvus*, *poeticus plenus*, and the Jonquil.

**Use of Cold Frame (A Beginner).**—As you do not appear to wish to devote the frame in winter to protecting young Cauliflowers or Lettuce plants, nor the whole of it to *Calceolaria* cuttings, you can insert cuttings of *Pentstemons* in it, also *Gazania* and *Violas*, all of which are of service in the flower garden. The frame will also be suitable for wintering Carnations in small pots, Auriculas, and Hollyhocks; or if you prefer, you may insert cuttings of Roses in it. Early next April it can be taken off, the partially hardy plants being protected with boards placed round, and mats across, supported with strips of wood, and the frame placed on a mild hotbed for raising various kinds of half-hardy annuals for summer, subsequently planting Cucumbers. It is useless sowing seed of any kind in the autumn or winter in the frame. A great deal depends on individual aptitude in turning frames to the best account, due regard being paid to the particular requirements in each case, these varying considerably.

**Plants for Hall (Idem).**—Some of the hardier Palms are very suitable, and with good management the following may be kept healthy for a considerable time: *Areca sapida*, *A. lutescens*, *Cocos Weddelliana*, *Geonoma gracilis*, *Kentia Belmoreana*, *Phoenix rupicola*, *Rhapis flabelliformis*, and *Seaforthia elegans*. *Ficus elastica* answers very well for such positions, and *Aspidistras* are excellent for dry corridors. Of Ferns the strong-growing *Pterises longifolia*, *tremula*, and *unabrosa* might be tried, also the green *Dracenas congesta* and *australis*, with the handsome Conifer *Thujaopsis dolabrata*, which is very elegant, and with good attention continues healthy for years in light corridors.

**Lifting Vines (W. B.).**—As the inside border is so narrow we presume the roots have access to a border outside, or at least have found their way out of the confined space to which you refer. If that is so the work will be easy, as you may clear out the whole of the narrow border, and after providing ample drainage and free exit for water place the roots in fresh soil, taking care that they are kept moist while the work is in progress. Turfy loam dug from a pasture inclining to be strong rather than light should form the staple, adding to twenty barrowfuls two or three each of lime rubbish and wood ashes or crushed charcoal, a peck of soot, and half a bushel of crushed bones, if you can get them. Mix well, and take care that the compost is pleasantly moist for working, and press it down rather firmly, but it must not be very wet. Spread the roots out straight, cutting off all jagged ends and bruised portions, and cover 4 inches deep with soil; then mulch with the same thickness of half-decayed manure for preventing the escape of moisture. The work may be done as soon as the fruit is cut, and if the leaves show signs of flagging syringe and shade as may be required for keeping them fresh. New roots will then form before winter, and after they have taken possession of the soil the border may be renewed next year. Your plants are referred to outside below.

**Melon Roots Clubbed (M. P.).**—Your plants are attacked with the same disease that ruins so many Cucumber plants, and is the worst example as affecting Melons we have seen. We have nothing to add to the reply we gave to another correspondent a few weeks ago, as follows: This disease is due to, in most cases, an excess of organic matter in the soil, especially vegetable or animal matter, generating humus, with its attendant nematoid germs. The corrective for this is to char the soil before use so as to destroy the nematoid germs, and also reduce the excess of organic matter over the inorganic, by which a more healthful plant is secured, safeguarding against disease; or, in the case of soil not full of vegetable matter or fibre, therefore not likely to contain the germ of disease, manures of a kind calculated to strengthen the plant in proportion to its vigour should be employed, as superphosphate (dissolved bones), soot, and wood ashes, so that lime, potash, &c., will be available for building up the plant's structure, which, with due regard to other cultural requirements, are the only preventive measures that avail, remedial ones being of questionable efficacy through the disease being internal, and to reach it requires measures destructive of the plants. The only advice we can give is to root out the plants and soil, making a fresh start with healthy plants, fresh and sweet soil, observing cleanly culture.

**The Chrysanthemum Bug (Wordsworth).**—The insects you sent have been examined by our entomologist, who reports thereon as follows:—"In reference to the insects sent and reported to occur upon the Chrysanthemum, I have to state that they are quite distinct, but both belong to the Hemipterous order—that is to say in common phrase, they are "bugs." I am sorry to say that our present knowledge of this order is a disgrace to us entomologists; it has been neglected as a whole, partly, perhaps, because, owing to the insects living by suction, they are not easy to rear. Hence I can only pronounce the larger one doubtfully to be an example of the

variable *Ptyelus bifasciatus*, which occurs on many plants during summer. I do not think it is likely to be the cause of any serious injury to the *Chrysanthemum*. The smaller insect is one of a group that certainly does harm to plants by piercing both leaves and young shoots with its rostrum. Apparently it belongs to the genus *Systellinotus*; it could not, however, be determined unless I had several specimens alive or in better preservation. It is curious to observe that many of these bugs are fond of plants aromatic or bitter, such as the *Chrysanthemum* and allied Composites. Such being the case they would probably defy attempts to kill them by bitter solutions or decoctions, such as those of quassia or hellebore. I fancy soap would be very injurious to them."

**Strawberry Plants Blighted** (*William Raynor*).—The runners are in the condition known as "blasted," and it is caused chiefly by too arid an atmosphere. The plants usually grow out of it when the atmospheric conditions are favourable. We have known it caused by too rapid evaporation, as sometimes results when a current of air is suddenly admitted directly upon the plants after the atmosphere has been raised considerably by the sun heat. This causes a chill through extreme evaporation, in consequence of which the foliage assumes a brown hue, having the appearance of being burnt, whilst the fruit is similarly affected, the skin becomes hardened, and the fruit swells very little if any afterwards, being rusty-looking, not infrequently cracks, and is worthless. The remedy is to afford a moister and more uniformly genial condition of the atmosphere. The remedy outside is to mulch and afford adequate supplies of water, plants in pots being sprinkled over the leaves in the evening of hot days. There is a rust due to fungoid growth, but it is mostly constitutional, and is probably occasioned by a deficiency of potash, inasmuch as it infests plants that are grown in soils deficient of that substance. Additions of charred refuse or wood ashes are then valuable. In some instances we have known the rust entirely disappear through plants being potted in the charred refuse of the rubbish heap; also from those in the open ground through a dressing of similar material. Burned clay also has a very beneficial effect on soils the plants on which are subject to rust; and kainit, a cheap form of potash, is also good, especially if accompanied where the plants are weak by a dressing of nitrate of soda. A pound each per rod is sufficient.

**Roses for Forcing** (*B. D.*).—For producing flowers about Christmas you will have to rely entirely upon Tea varieties. The best for this purpose are Safrano, Niphotos, Isabella Sprunt, Catherine Mermet, Madame Falcot, Madame Lambard, and Marie Van Houtte. The first three will yield considerably more flowers than the others, and none will equal Safrano in the number of buds produced at that period of the year. If you require any for the roof you could not do better than employ the old *Gloire de Dijon*. For the next compartment any or all those named above can be employed, as well as the following:—Alba Rosea, Rubeus, Anna Ollivier, The Bride, Comtesse de Nadaillac, Comtesse Riza du Parc, Etendard de Jeanne d'Arc, Grace Darling, Innocente Pirola, Jean Ducher, Madame Angele Jacquier, Madame Hippolyte Jamain, Madame Willermoz, Perle de Lyon, President, Etoile de Lyon, Souvenir d'un Ami, Sunset, Souvenir de Paul Neyron, Princess of Wales, Perle des Jardins, and Souvenir d'Elise. For training over the roof Maréchal Niel, William Allen Richardson, Cheshunt Hybrid, Reine Marie Henriette, Belle Lyonnaise, and Lamarque. For growing in pots or even planting out, the following Hybrid Tea varieties are invaluable for flowering early in the season: Distinction, Cameons, Lady Marie Fitzwilliam, and W. F. Bennett. If you only grow one of these, choose the last; if two, the two last. Of Hybrid Perpetuals for forcing, either planted out or growing in pots, the latter preferably when the main body of the house is occupied with Tea kinds, for during the summer they are better outside than under glass—the following are amongst the best: La France, Général Jacqueminot, Jules Margottin, Louis Van Houtte, Abel Grand, Magna Charta, Bessie Johnson, Camille Bernardin, Charles Lefebvre, Docteur Andry, Madame George Paul, Marie Baumann, Alfred Colomb, Duke of Edinburgh, Duke of Teck, Fisher Holmes, François Michelin, Victor Verdier, John Hopper, Hippolyte Jamain, Madame Gabriel Luizet, Madame Victor Verdier, Madame Marie Finger, Merveille de Lyon, Baronne de Rothschild, Prince Camille de Rohan, Séateur Vaisse, Ulrich Brunner, and Prince Arthur. Many of the Tea varieties or even the whole of them might be included in your earliest house, but they would not flower freely before the month of February or early in March. They would, of course, be considerably weakened by a few months' forcing, and would not do so well afterwards as would be the case if brought forward gradually later in the season. Although the list for flowering at Christmas is a limited one, we should prefer to plant only the few varieties named to a greater number, and we advise you to do the same if quantity of Roses at that season is your object.

**Names of Fruits.**—The names and addresses of senders of fruit to be named must in all cases be enclosed with the specimens, whether letters referring to the fruit are sent by post or not. The names are not necessarily required for publication, initials sufficing for that. Only six specimens can be named at once, and beyond that number cannot be preserved. (*W. B. R.*)—Benrre Giffard. The last edition of the "Fruit Manual" is the fifth, price 15s.

**Names of Plants.**—We only undertake to name species of plants, not varieties that have originated from seed and termed florists' flowers. Flowering specimens are necessary of flowering plants, and Fern fronds should bear spores. Specimens should arrive in a fresh state in firm boxes. Slightly damp moss or soft green leaves form the best packing, dry cotton wool the worst. Not more than six specimens can be named at once. (*W. B.*)—1, *Tradescantia virginica*, a hardy border plant; 2, not recognisable without flowers. (*A. B.*)—*Sambucus racemosa*. ( *Eaton*).—1, *Achillea Ptarmica* flore pleno; 2, *Papaver nudicaule*; 3, *Clintonia pulchella*; 4, *Lychuis Haageana*. (*T. L.*)—1, *Cuphea platycentra*; 2, *Pentas carnea*; 3, *Rudbeckia Newmani*. (*F. O.*)—1 is a *Salpiglossis*; 2, *Oenothera speciosa*. (*G. Adams*).—*Veronica Andersoni variegata*. (*W. Wells*).—*Olearia Haasti*. (*A. Z.*)—1, *Lignstrum japonicum*; 2, *Leycesteria formosa*; 3, *Hibiscus syriacus*; 4, *Passiflora coccinea*; 5, *Cobaea scandens*; 6, *Ecce-mocarpus scaber*.

COVENT GARDEN MARKET.—AUGUST 17TH.

		s. d.		s. d.	
Apples, 1/2 sieve	0 0	to	0 0		
Nova Scotia and Canada barrel	0 0		0 0		
Cberries, 1/2 sieve	5 0		8 0		
Cobs, 100 lbs.	0 0		0 0		
Figs, dozen	1 6		2 0		
Grapes, per lb.	1 6		2 6		
Lemons, case	10 0		15 0		
Melons, each	2 0		3 0		
Oranges, per 100	6 0	to	12 0		
Peaches, dozen	2 0		6 0		
Pears, dozen	1 0		1 6		
Pine Apples, English, per lb.	1 6		0 0		
Plums, 1/2 sieve	0 0		0 0		
St. Michael Pines, each	3 0		5 0		
Strawberries, per lb.	0 0		0 0		

VEGETABLES.

		s. d.		s. d.	
Artichokes, dozen	1 0	to	2 0		
Asparagus, bundle	0 0		0 0		
Beans, Kidney, per lb.	1 3		0 0		
Beet, Red, dozen	1 0		2 0		
Broccoli, bundle	0 0		0 0		
Brussels Sprouts, 1/2 sieve	0 0		0 0		
Cabbage, dozen	1 6		0 0		
Capicums, per 100	1 6		2 0		
Carrots, bunch	0 4		0 0		
Cauliflowers, dozen	3 0		4 0		
Celery, bundle	1 6		2 0		
Coleworts, doz. bunches	2 0		4 0		
Cucumbers, each	0 4		0 6		
Endive, dozen	1 0		2 0		
Herbs, bunch	0 2		0 0		
Leeks, bunch	0 3		0 4		
Lettuce, dozen	0 9	to	0 0		
Musbrooms, punnet	0 6		1 0		
Mustard and Cress, punt.	0 2		0 6		
Onions, bunch	0 3		0 6		
Parsley, dozen bunches	2 0		3 0		
Parsnips, dozen	1 0		0 0		
Potatoes, per cwt.	4 0		5 0		
" Kidney, per cwt.	4 0		0 0		
Rhubarb, bundle	0 2		0 0		
Salsafy, bundle	1 0		1 6		
Scorzoneria, bundle	1 6		0 0		
Seakale, basket	0 0		0 0		
Sballots, per lb.	0 3		0 0		
Spinach, bushel	3 0		4 0		
Tomatoes, per lb.	0 4		0 6		
Turnips, bunch	0 4		0 6		

PLANTS IN POTS.

		s. d.		s. d.	
Aralia Sieboldi, dozen	6 0	to	12 0		
Arbor vitæ (golden) dozen	6 0		9 0		
" (common), dozen	0 0		0 0		
Azalea, dozen	0 0		0 0		
Begonia, dozen	4 0		9 0		
Calceolaria, dozen	3 6		8 0		
Cineraria, dozen	0 0		0 0		
Creeping Jenny, dozen	3 0		4 0		
Dracana terminalis, doz.	30 0		60 0		
" viridis, dozen	12 0		24 0		
Erica, various, dozen	0 0		0 0		
Euonymus, in var., dozen	6 0		18 0		
Evergreens, in var., dozen	6 0		24 0		
Ferns, in variety, dozen	4 0		18 0		
Ficus elastica, each	1 6		7 0		
Foliage Plants, var., each	2 0		10 0		
Fuchsia, dozen	3 0	to	9 0		
Geranium (Ivy), dozen	3 0		6 0		
" Tricolor, dozen	3 0		6 0		
Hydrangea, dozen	9 0		12 0		
Lilies Valley, dozen	0 0		0 0		
Lilium lancifolium, doz.	12 0		18 0		
" longiflorum, doz.	18 0		24 0		
Lobelia, dozen	3 0		5 0		
Marquette Daisy, dozen	6 0		12 0		
Mignonette, dozen	3 0		6 0		
Musk, dozen	2 0		4 0		
Myrtles, dozen	6 0		12 0		
Palms, in var., each	2 6		21 0		
Pelargoniums, dozen	6 0		12 0		
" scarlet, doz.	3 0		9 0		
Spiræa, dozen	0 0		0 0		

CUT FLOWERS.

		s. d.		s. d.	
Abutilons, 12 bunches	2 0	to	4 0		
Anemones, 12 bunches	0 0		0 0		
Arum Lilies, 12 blooms	3 0		6 0		
Asters, 12 bunches	3 0		6 0		
" French, bunch	1 6		2 0		
Azalea, 12 sprays	0 0		0 0		
Bluebells, 12 bunches	0 0		0 0		
Bouvardias, bunch	0 6		1 0		
Camellias, blooms	0 0		0 0		
Carnations, 12 blooms	1 0		2 0		
" 12 bunches	4 0		6 0		
Cornflower, 12 bunches	1 6		3 0		
Dahlia, 12 bunches	3 0		6 0		
Daisies, 12 bunches	2 0		4 0		
Encharis, dozen	4 0		6 0		
Gardenias, 12 blooms	1 6		3 0		
Hyacinths. Roman, 12 sprays	0 0		0 0		
Iris, 12 bunches	0 0		0 0		
Lapageria, white, 12 blooms	0 0		0 0		
Lilium longiflorum, 12 blooms	3 0		6 0		
Lilium lancifolium, 12 blooms	1 0		2 6		
Lilac (white), French, bunch	0 0		0 0		
Lilies, White, 12 bunches	0 0		0 0		
" Orange, 12 bunches	0 0		0 0		
Lily of Valley, 12 sprays	0 0	to	0 0		
" 12 bunches	0 0		0 0		
Margneritos, 12 bunches	2 0		6 0		
Mignonette, 12 bunches	1 0		3 0		
Myosotis, 12 bunches	2 0		3 0		
Narciss, 12 bunches	0 0		0 0		
" White, English, bch.	0 0		0 0		
Pansies, 12 bunches	0 0		0 0		
Peas, Sweet, 12 bunches	3 0		6 0		
Pelargoniums, 12 trusses	0 9		1 0		
" scarlet, 12 trusses	0 4		0 6		
Pinks, White, 12 bunches	0 0		0 0		
" various, 12 bunch	2 0		4 0		
Pony, 12 bunches	0 0		0 0		
Poinsettia, 12 blooms	0 0		0 0		
Primula (single), bunch	0 0		0 0		
" (double), bunch	0 9		1 0		
Polyanthus, 12 bunches	0 0		0 0		
Rannoculus, 12 bunches	0 0		0 0		
Roses, 12 bunches	2 0		6 0		
" (indoor), dozen	0 9		1 0		
" Tea, dozen	1 6		3 0		
" red dozen	0 0		0 0		
" de Mois, 12 bunches	0 0		0 0		
Stephanotis, 12 sprays	2 6		4 0		
Tropæolum, 12 bunches	1 0		2 0		
Tuberose, 12 blooms	0 6		1 0		
Tulips, dozen blooms	0 0		0 0		



AGRICULTURAL EXPERIMENTS.

Much good work is now being done all over the country by intelligent thoughtful men, whose minds are thoroughly aroused to the importance of improvements in our practice as farmers if we are to overcome the difficulties of a depression to which no ordinary remedy can be applied. Our great agricultural societies, local associations, and private individuals are all working to the same good purpose and end, and there can be no doubt that results of much importance will eventually be obtained.



Meanwhile it will be well to guard ourselves against hasty conclusions about any of them, for such conclusions often prove false, and eventually do more harm than good.

A recent inspection of some of the Norfolk experimental stations have served to strengthen our conviction that much care, patience, and perseverance are required to bring the trials to a satisfactory conclusion by making them thoroughly exhaustive, which we submit can only be done by extending them over several consecutive years. The chief reason for this is that our climate is so changeable that results must be affected by the peculiarities of each season, and it is only by a comparison of results of several seasons that really useful deductions can be had. Take, for example, the Dyson's Wood experiments, of which it is positively asserted that they have already shown that it is wrong to apply either nitrate of soda or sulphate of ammonia to permanent pasture, or in other words that nitrogenous manures must not be used because they are liable to induce so robust a growth in the stronger-growing grasses that the more delicate grasses and Clovers would be spoilt. Now, considerable experience in the use of chemical manures upon pastures enables us to say positively that such a conclusion is both hasty and misleading. We may certainly venture to say that Mr. Martin John Sutton's object is not simply to ascertain which manures are best for his purpose, but rather in what proportions nitrogen, potash, and phosphorus should be used. It is simple nonsense to say that manures for pasture are required principally for Clovers and the finer grasses; bulk of crop cannot be ignored, and in order to obtain it we must have plenty of the stronger-growing grasses. What after all do we require in a forage crop but nutritious food for our sheep and cattle? and we know by that best of all tests—practical results, that we have plenty of nutriment in Cocksfoot and Rye Grass.

For the outcome of agricultural experiments to be of practical value to the ordinary farmer they must show him how, by good husbandry in conjunction with the use of certain manures, he may so increase the produce of his land as to render his calling again profitable. This must be done in a clear and simple yet comprehensive manner. It is not enough to tell a man that a given quantity of manure must be used, but he must know how and when to use it. There can be no doubt that severe losses have happened simply through the improper use of chemical manures. Repeatedly have we shown our readers that annual surface dressings of chemical manures on pastures in February insure a full crop of hay, but if applied a month or two later successful results would be proportionately uncertain, because we must have enough rain to dissolve and wash in the manures. The mention of this fact reminds us of a want upon many, or we might say most farms, and that is a water cart with a spreader attached to it for watering pasture. In the present summer it would prove invaluable if kept in regular daily use, tending as it must to insure plenty of food for grazing stock. Many a dairy farmer is at a loss for green food now, and more money is being spent upon the purchase of food than would suffice to keep several water carts going. This remark is perhaps a little wide of our subject, but we hold that it is well always to jot down useful thoughts as they occur, and if water carts were to have a place among ordinary farm implements they could be used in dry springs to dissolve chemical manures, and so render their action speedy and certain.

Improved sorts of corn have had due attention in our own experiments this season, and we hope to have some

useful hints to offer thereupon later on. Just now we are making a comparison of various sorts of Wheat, in order to ascertain which are the most profitable. We have new sorts of both Red and White Wheat with long loose ears, and we question very much if they will prove to yield better than short stout compact ears. A twenty-acre field of Webb's Giant White Wheat is very fine, but hitherto this Wheat has proved both small in grain and light in weight. We have it this year upon four farms, and shall be able to come to a decision as to its real value.

WORK ON THE HOME FARM.

The corn harvest has not proved so late this year as was at one time anticipated, for drought and heat brought on the corn to maturity so early that fully two-thirds of it was cut, and some of it carted in the first week of August. Wheat generally is an excellent crop, quite above the average, and much of it will yield full five quarters an acre. The quality of the Wheat will also be high, the grain being so dry and hard when carted to the stack as to be ready for immediate threshing. That advantage of this fact will be taken by many a needy farmer is probable, for we much fear that many a man has difficulty in finding money for harvest expenses. Oats, though small in grain, are comparatively heavier in weight than the crop of last year, but there are many fields of Oats below the average in bulk of crop. The finest crops we have seen were early sown Black Tartarian. Barley of high quality should prove plentiful enough, and there should be a recovery in price from the exceptionally low rates of last year. On many farms where the land is highly cultivated the crop is a heavy one, and if the price for superior samples of best malting Barley should reach 40s. a quarter it will indeed prove a boon to the growers.

As the stubbles are cleared pigs, sheep, and turkeys are all turned upon them to consume fallen corn. In doing this with sheep some caution is necessary, as they are quite certain to eat the corn greedily, and may take so much of it as to sustain harm. Pigs, on the contrary, can hardly be over-fed, and may be suffered to remain out upon the stubble all day. We like to do this with promptitude immediately after harvest, and then to lose no time in breaking up and clearing the stubbles. A neighbour of ours had a field of Peas so foul with weeds and wild Oats that he had the Peas all pulled by hand from among the weeds, which were subsequently consumed by folding sheep upon them. The drought has told so much upon pastures that many flock-masters are at their wit's end for food for sheep. Clover layers that were mown for Clover have such a short second growth that it is only suitable for sheep-grazing.

OUR LETTER BOX.

Poor Pasture (J. I. K.).—Italian Rye Grass is a biennial, and therefore your field of it will answer well another season if you give it a dressing of the chemical manures we recommended, next February, but you might also use nitrate of soda as advised in showery weather now to promote a free autumnal growth. We are not surprised that your pasture is bare now after so long a drought; it is only on marsh land and deep cool alluvial soil that green pasture is to be seen now. Your mixture of Rye Grass—if the perennial sort—Cocksfoot, Timothy, Red Clover, White Clover, Alsike, and Cow Grass is a good one, and should give you a productive pasture, if you apply chemical manure in February, or better still fold it with sheep. As you, however, appear to require it for cows, apply the chemical manure regularly in February, and take special care that none of the Grass is suffered to run to seed, but is either mown or eaten off before seeding is possible.

METEOROLOGICAL OBSERVATIONS.

CAMDEN SQUARE, LONDON.

Lat. 51° 32' 40" N.; Long. 0° 8' 0" W.; Altitude, 111 feet.

DATE.	9 A.M.					IN THE DAY.				Rain
	Baromet. ter at 32° and Sea Level.	Hygromet- ter.		Direction of Wind.	Temp. of soil at 1 foot.	Shade Tem- perature.		Radiation Tem- perature		
		Dry.	Wet.			Max.	Min.	In sun.	On grass	
1887. August.	Inches.	deg.	deg.		deg.	deg.	deg.	deg.	deg.	In.
Sunday .....	30.078	74.3	61.2	S.W.	65.2	82.3	56.1	127.6	51.4	—
Monday .....	30.239	63.5	58.2	S.W.	65.3	86.2	52.9	127.4	50.4	—
Tuesday ...	30.171	69.1	59.2	N.W.	66.0	82.7	56.6	128.3	53.6	—
Wednesday ...	30.096	69.9	51.5	N.E.	66.4	74.6	55.4	117.2	53.3	—
Thursday ...	30.101	58.7	52.2	N.	65.7	72.3	54.9	119.2	52.3	—
Friday .....	29.979	59.3	52.8	N.E.	65.2	70.7	54.6	114.7	52.5	—
Saturday ....	29.806	61.3	55.3	E.	64.9	70.6	54.8	114.3	52.6	—
	30.067	64.7	55.8		65.6	77.1	55.0	121.2	52.4	—

REMARKS.

7th.—Bright, fine, and warm.  
 8th.—Fine, bright, and hot.  
 9th.—Bright and warm.  
 10th.—Cloudy morning, fine afternoon; cool all day.  
 11th.—Cloudy early; bright, cool, pleasant day.  
 12th.—Cool, with easterly wind and generally cloudy.  
 13th.—Cloudy nearly all day, slight shower in late evening, but not yielding a measurable amount.  
 The tenth successive hot week, and a second consecutive rainless one.—G. J. SIMONS



## COMING EVENTS

25	TH	Reading Show.
26	F	Sandy Show.
27	S	Sale at Stevens' Rooms.
28	SUN	12TH SUNDAY AFTER TRINITY.
29	M	
30	Tu	Newcastle Show (three days).
31	W	

### PEARS.

**U**NDER the above title an early copy of the Report of the Committee of the National Pear Conference that was held in the Royal Horticultural Society's Gardens in 1885, has been sent to us with a request that we notify to our readers that the volume may be obtained free of cost by Fellows of the Society on application to the Assistant-Secretary at South Kensington, and by the public generally from Messrs. Macmillan & Co., Bedford Street, Covent Garden, price 2s. 6d. The work has been compiled by Mr. A. F. Barron, and forms an admirable companion volume to "British Apples" issued in 1884, as a permanent and valuable record of the Apple Congress that was held in 1883. The Pear Report consists of 230 pages, and will be acceptable to the Fellows of the Society, and it is commended to all cultivators of the prince of hardy dessert fruits as the most complete work obtainable on the subject to which it is devoted.

The exhibition of Pears on which the Report is founded was the most extensive and complete that has been arranged in this country. It comprised 6269 dishes in 616 reputed varieties, and after the official scrutiny it is surprising to see how comparatively few of them were synonymous, the list of these being published at the end of the work. A descriptive catalogue of the entire number staged by 167 exhibitors is also incorporated in the volume. This substantial Report is, however, a great deal more than a catalogue, for it contains more cultural information and hints on the management of Pears from a greater number of the best growers of them than has ever been presented in such a handy form. It may be fairly described as a work of a hundred authors, for about that number have contributed to its pages, some briefly, others more fully; indeed, the compiler was no doubt overwhelmed with material, and its compression into the space at disposal could have been no easy task. If in a multitude of councillors is wisdom, all who are seeking information on Pears and their culture will find wisdom in the work under notice, and this, too, at a convenient time—namely, within two or three months of the planting season, or sufficiently long for the pages to be studied whereon the experience of this multitude of good Pear growers is inscribed.

As might be expected under the circumstances, when a number of experts are writing on the same subject—the choice of varieties and methods of culture—there is a considerable amount of repetition; but this is by no means tedious in consequence of the diversity of expression in which the opinions and practices of the several contributors are conveyed; and what may be regarded as repeti-

tion may perhaps be more accurately represented as a concurrence of testimony in favour of varieties and methods. But this obviously does not weaken but strengthen the evidence that points to the best results, and these, as will be seen, are invariably attained by good cultivation, and mainly with trees on the Quince stock. This is well expressed in the deductions recorded on page 9 of the Report as follows;—

"Without entering into minute comparison of the merits of the different collections exhibited, it is important to notify this fact—that the cultivation of good Pears does not seem to be confined to any particular climate or district of the country. If we take the magnificent examples from M. Joshua Le Cornu of Jersey as the result of good and careful cultivation, we have their equals produced by Mr. Haycock and by Mr. Thomas in Kent, and closely followed by Mr. Wildsmith in Hampshire, and Mr. Breese in Sussex. Many other individual examples throughout the Exhibition were equally meritorious. No one failed to remark on the excellence of the examples from Lord Chesterfield, Herefordshire, or those still further north from Mr. Dalrymple, St. Boswells, Scotland, which were probably as meritorious as any at the Conference. Nothing contributed so much to these successful results as good and careful cultivation. It may be taken as a general rule that the best fruits are produced where the greatest care is bestowed. An important factor in the successful cultivation of the Pear, as gathered from the returns, is in the use of the Quince stock, which, from its close surface-rooting character, is more directly amenable to the attentions of the cultivator."

That may be taken as a fair epitome of the collective wisdom embodied in the work, and it is both encouraging and suggestive.

But there are soils and districts in which the Pear stock is more satisfactory than the Quince. We could indicate some not mentioned in the Report, though evidence is not wanting in it in support of the proposition. Mr. G. Palmer, gardener, Drinkstone Park, Bury St. Edmunds, remarks:—

"Situation, on a dead level. Soil, medium loam; sandy to gaulty subsoil. Our collection of Pears here are grown on trained trees on walls, espaliers, pyramids, and a few standards. The Quince stock is represented in each form of tree, excepting the standard, and with plenty of evidence of weakness and short life. The Pear is certainly preferable as a stock in this immediate locality."

The examples he exhibited are described as "large, clear, and well grown."

Mr. M. Dunn of Dalkeith, who is one of the last men to form an erroneous opinion on the subject, after describing the soil as a light loam heavily manured, subsoil open gravel, observes:—

"As a rule, the Quince stock is not so successful as the free stock here; it generally does pretty well for a few years, and then invariably goes barren, and some sorts never do well on it at all. Our trees seldom get over-luxuriant, and suffer less from gross growth than from starvation or want of moisture and manure. In ordinary seasons, and on well-manured ground, trees on the Pear or free stock seldom fail to bear a crop, even to a great age; while no amount of manure seems to have any effect in promoting fertility in a tree on the Quince stock after it begins to show signs of distress."

Mr. H. Divers of Ketton Hall, an excellent fruit grower, closes his remarks by saying the stocks preferred are "the Quince for wet and heavy soils, the Pear for light and dry soils."

Mr. W. Wildsmith of Heckfield, who is credited with "one of the most meritorious collections exhibited," in summarising his method of culture indicates the nature and requirements of trees on different stocks. We cite his remarks:—

"Situation sheltered, open to south and east. Soil, light sandy  
No. 2030.—VOL. LXXVII., OLD SERIES.

loam, resting on gravel and sand. Our soil being light, it is trenched deeply before planting, a few half-inch bones being all the manure that is mixed directly with the soil, preference being given to manuring by surface mulchings of farm or stable-yard manure. As a rule, the trees are lifted and replanted the second year after being first planted, a plan that, as regards trees on the Quince stock, renders any further root-pruning to promote fertility unnecessary. Trees on the Pear stock are treated exactly the same when first planted, but they grow so luxuriantly that we have to partially root-prune them once in three years. As regards pruning, the young growths being closely pinched back twice during the summer, very little winter pruning is needed other than the removal of a shoot that may be crowding another, or a long spur that has become budless at its base. I have a decided preference for the Quince stock, but it should be understood that high feeding is a necessity to keep the trees growing; fruiting goes without saying—those who don't mean to feed, and don't like hard work, and yet want a few Pears, should stick to the natural stock."

Though, as will be seen from the above extracts, the Pear stock is better adapted than the Quince to certain soils and positions, yet the evidence conveyed in the Report is overwhelmingly in favour of the latter, and for the reason mainly that its roots do not as a rule extend so far nor penetrate so deeply as do those of the Pear stock, and consequently more quickly appropriate the virtues of manures that are applied to the advantage of the trees and crop. This is not overlooked in the remarks accompanying the fruit that was sent from Chiswick, in which also are embodied good hints on summer pruning, and the necessity of a thin disposal of the main branches of the trees. Here are those remarks:—

"Situation sheltered, but low-lying; consequently frequently subject to late spring frosts. Soil, rather a heavy loam, approaching to clay; subsoil, gravel. The greater portion of the fruit shown was grown on pyramid trees about 20 feet in height, chiefly on the Quince stock, which is found much more fruitful and suitable than the Pear, being more directly amenable to cultural skill. The trees are carefully pinched in summer, and spur-pruned during the winter. The practice followed is to stop the shoots during the month of July at about the fifth bud from the base, taking care to stop only those on the upper part of the tree, or such as may be growing strong, the weaker shoots and those on the lower part being allowed to grow for a week longer or more before stopping. Thus checking the stronger first and permitting the weaker to grow tends to regulate the flow of sap, and equalise the strength throughout. Another very important matter is to keep the branches thin and clear of each other, so that every part of the tree may be freely exposed to the direct influence of the sun and air. More pyramid trees are rendered unfruitful through this crowding of the shoots than from any other cause. Root-pruning is only resorted to occasionally (and generally with those on the Pear stock), when the trees grow very luxuriantly, and cannot otherwise be checked. During dry weather the ground is mulched and well watered."

It will be admitted from the few examples given that this Report abounds in useful information pertaining to culture, and at the same time lists of varieties of Pears are furnished that have been found suited to the various districts of the kingdom, the selections having been made by cultivators in the different localities.

The Report concludes with an audit of the Pears selected by the exhibitors, the poll being taken for the whole of Great Britain, varieties that obtained only one vote being omitted. A column is also provided showing the number of dishes staged of the selected varieties. As is stated in comment on the results of the audit:—

"These returns are instructive as showing the appreciation in which particular varieties are held throughout the country. Marie Louise stands at the head of the list as the most popular Pear, having been selected ninety-eight times out of a possible 100. Louise Bonne of Jersey is second favourite, having received eighty-seven votes, closely followed by Williams' Bon Chrétien for the third place, eighty-six votes. Of those exhibited at the Conference, Beurré Diel heads the list, 194 dishes of this variety having been staged, Marie Louise coming second, 155 dishes, and Louise Bonne of Jersey third, 132 dishes.

"Amongst Pears suited for orchard culture, the popular variety is Williams' Bon Chrétien, this having been selected fifty times; and, secondly, Louise Bonne of Jersey, forty-six times; Beurré de Capiaumont third, thirty-eight times; and of stewing Pears, Catillae, Uvedale's St. Germain, and Bellissime d'Hiver secured the highest number of votes respectively.

"It may be noted that of the old-fashioned Pears, if we except the Jargonelle and Hessel, scarcely any of the others have merited a place, even for orchard cultivation; such varieties may therefore be considered as worthless and should be discarded."

In respect to the Marie Louise Pear there appears to be a misprint, for in the tabulated list 93 votes are recorded. The hardy and useful old orchard Pear called "Hessel" derives its name from the Yorkshire village of Hessele. As the Report will be taken as an authority on Pears the greatest possible accuracy is desirable in the rendering of their names, and it is pleasant to observe that out of so many the "slips" are so few. All gardeners and amateurs who are interested in Pears and their culture should possess this comprehensive, suggestive and interesting Report.

#### ASPARAGUS CULTURE.

(Continued from page 93.)

VARIETIES.—Some persons see no difference in this respect, but to my eye there is considerable difference in the varieties, yet for all practical purposes the variations may be deduced to three—viz., Early Purple-topped Agenteuil, the earliest, large, quick, and abundant in produce, and hardy; Connoyer's Colossal, large, paler, and not so abundant cropping as either of the others, nor so hardy or early; Giant, or Battersea, large abundant cropping, and in every respect excellent. All are good. I prefer them in the order named; the first for its earliness, the second for its size, and the third for good cropping qualities.

SITUATION.—It must be open, exposed to every ray of sun, and catching every breeze. There is advantage in warmth if it is not drying, and in shelter if not drawing, therefore keep the plants or beds away from trees, hedges, and walls to avoid their shading and drying effects.

RAISING PLANTS.—Asparagus is raised from seed either by sowing where the plants are to remain, or for transplanting. Which is the better plan? It depends on circumstances. There is a consideration as regards the seedlings. The seeds may be off the same haulm, yet the seedlings will have degrees of excellence, and the transplanting admits of a choice of plants, which is precluded by sowing where they are to remain. Ground is in many places a consideration, and sowing for transplanting allows of a more profitable employment of the soil. Those are weighty considerations, but I prefer sowing where the plants are to remain, for I fail to see what is culturally effected by transplantation beyond convenience, and what is lost in ground is made up in the earlier and superior produce. The spaces between the seedlings can be utilised for the first two or three years, so that there is no waste of ground. This is a consideration, and one that had better be left out, for between-cropping takes from the ground we have considered necessary for the successful cultivation of Asparagus, and the soil is impoverished for Asparagus to the extent of the crop taken; therefore I ask that the ground set apart for Asparagus be not impoverished by alien crops, for if between-cropping is necessary to utilise the ground the principal is too distantly placed for its profitable occupation. These considerations raise moot questions—the best methods of growing Asparagus so as to obtain the best returns from the land, for we must allow of there being two sides to the question—viz., grand results irrespective of space and means, and profitableness resulting from a judicious employment of land and means. I shall, perhaps, best meet all tastes and requirements by describing the methods most advisable to attain the desired object.

In order to raise plants for transplanting I sow the seed in drills 1 foot apart, and an inch deep early in April, covering with fine soil. Every fifth row is omitted for convenience of cleaning. The seeds are placed 2 inches apart, and all are allowed to grow until early June, when or before which they will be in second "feather." Now mark the plants well. Some will have a strong first feather, and a second growth coming, or to be much stronger. That is the one wanted. Others will have weaker and more numerous feathers; grub those out with a hand-fork, leaving those that have single and strong feather as near 6 inches apart as we can get them. The exact distance is not material, the main thing is to get the plants of the character indicated, as the plants are only intended to remain a year before transplanting. The first feather is to be cut away in favour of the second when the latter overtops it, or when it is well advanced in growth, and this second shoot is to be shown every favour through the season, cutting all others away coming after early July, but if there arise another stronger shoot by midsummer day and the setting in of the dog days, select it, and cut away the second—in fact, save the best of the shoots appearing by or before midsummer, and cut all others away right through the season, as any coming after that time have no chance of forming well ripened buds. If a strong shoot



come later leave both. This is the treatment advised for the seedlings<sup>s</sup> in the first year to get plants with strong single crowns for planting. The shoots should be staked to prevent damage from wind. Either we must pursue the course above indicated or make selection of the seedlings at the time of planting, and in that case place the seed 3 inches asunder in the drills, and let all grow so as to give necessary plants for choice, but much finer plants are had by thinning to 6 inches.

**SYSTEM OF GROWING.**—I give preference to the ridge. It keeps the crowns from rotting, gives the plants the benefit of all or most the ameliorated and enriched soil, and allows of cruder and richer material being employed for feeding than plants in beds or on the level.

**PURPOSE AND METHODS OF GROWING.**—Asparagus is grown to eat—everybody knows that, but we have to consider in what way it is to be grown so as to please. There is the epicure—the heads must be large, fat, and luscious. Superlative produce is the result of superlative vigour of plant, and to get that the plant must have space—rows 4½ feet apart; and 3 feet distance in the rows, so as to admit of high-feeding and concentration of the vital forces on few parts from the commencement. Then we have the lovers of good heads—quality combined with quantity. High quality without much if any waste of space is had with the rows 4 feet apart, and the plants 2 feet asunder in the rows. Ordinary consumers like good heads and plenty of them. To meet those there must be no questionable use of ground and means—the most possible both in quality and quantity must be had, or there will be a balance on the wrong side of the ledger. Rows 3 feet apart and the plants 18 inches asunder give a quantity of high quality produce. There is yet another individual to be considered—viz., the grower that wants the most off the ground in the least possible time, and to pay. This is the most difficult person to satisfy. To get a paying price the heads must command the market, and the quantity must be proportionate. If a bundle from the plants 4 feet 6 inches by 3 feet bring double the price of a bundle from that at 3 feet by 18 inches, the latter may prove the more remunerative on account of the greater proportionate quantity. After making trial of plants at 18 inches and 12 inches asunder in 3 feet rows, I am bound to admit that the lesser distance is most desirable from its giving one-third more grass in the first three years of cutting, after which the greater distance plants come to the front and maintain the ascendancy, both as regards the quality and quantity. We have yet another want to cater for—viz., the grower who must grow two blades where other cultivators grow but one of grass: and this may be the gardener with limited space, or the man that holds land upon an insecure tenancy. These will cling to quantity until the end of the world, alleging necessity as the ground of their adherence. The rows for such may be 18 inches; and the plants 12 inches asunder, leaving out every fourth row. Such will grow fair Asparagus, and the plan is mentioned as it is a proper way of obtaining roots for forcing quite as much as to please clingers to obsolete practice, which encourages nothing but excluding such produce from the market or a self-inflicted capitulation of home produce against foreign.

**SOWING WHERE THE PLANTS ARE TO REMAIN.**—The ground being in good tilth draw the drills on the ridges an inch deep during the first week in April, and place the seed in patches at the distance they are wanted in the row, taking half the distance the plants are to be apart for the first, and then the full distance, one seed at the exact distance, and one on each side exactly an inch from it. Cover with fine soil. Early in June make choice of the best plant, and remove the others, merely drawing the soil aside and cutting off the top of the crown. Keep free of weeds, and thin the growths as previously advised for raising plants for transplanting. By midsummer or before the dog days sprinkle the ground about each plant with an ounce each of nitrate of soda and sulphate of ammonia for a space of about 18 inches all around, or apply that mixture over the whole ground at the rate of 2 ozs. per square yard. Mulch at once with a couple of inches thickness of any littery stuff at command, as spent hotbeds, old Mushroom bed refuse, stable litter, or farmyard manure. There is virtue in malt dust, in leaf soil, cocoa refuse, and even grass mowings. If the latter are used sprinkle with a little salt. At the beginning of the dog days soak with the contents of the cesspool poured on the mulching about the plants, and repeat up to the beginning of September every week, ten days, or fortnight, according to the weather. In autumn point over the whole of the ground, but not so as to injure the roots, and place a little soil over the crowns so as to cover them about 2 inches deep, disposing a similar thickness of partially decayed manure over each, about a forkful to each plant, and extending outwards a little so as to form a sort of cap. This is to be removed in March, leaving the soil only. The culture after the first year is the same as for planted out Asparagus.—G. ABBEY.

(To be continued.)

### HOLLYHOCKS.

THESE are certainly coming to the front again, and I hope that the committees of the August shows throughout the kingdom will recognise them for the future. Prizes for three and six spikes for amateurs, and six and twelve blooms for gardeners, would bring out many exhibits. I take an especial interest in the Black Country Shows of the Birmingham and Wolverhampton district, where the surroundings would lead strangers to suppose a flower show would be almost impossible. A truly wonderful exhibition of plants, flowers, and fruits were brought together at Bilston a few days since, and this place is in the midst of pit mounds, ironworks, and smoke. Two enormous tents and a good sized one also

were crowded out with exhibits, including splendid stove and greenhouse plants from Mr. Mangold, Birmingham, superb Dahlias from Kidderminster and other places, but the local people came out strongly in plants and flowers and especially vegetables. As I was desirous that Hollyhocks should be seen in good character in the district, I induced Mr. James Blundell, nurseryman, West Dulwich, to send down two dozen or so blooms of his varieties, and they most decidedly surprised not only the Black Country amateurs, but a great many outsiders, as the Hollyhock has been so little seen for many years. They were a fair lot of blooms, although there is something yet to be done to get them up to the standard of the old Lizzie, Glory of Waltham, and others of Paul's, Chater's, and Bircham's, and other raisers' days, but we are in the right direction, and it gives me most pleasant reminders of the old Hollyhock days when I think of Mr. Blundell's flowers.—W. D.

### NEW STRAWBERRY PLANTATIONS.

AUGUST is a very good month in which to form new Strawberry plantations. If strong plants are used they will grow to a good size before winter and produce a considerable quantity of fruit next season. Many growers assert that it is a mistake to keep Strawberry plants after they are three years old, but I have known many give highly profitable returns after that age, only there is little doubt that young healthy plants are more prolific than old ones, and all who possess Strawberry plants that are past their best should have no hesitation in rooting them up and introducing new ones. It is often said to be a mistake to take runners from unfruitful plants, as this is perpetuating an inferior type, but I never knew any well-grown Strawberry plant to be unfruitful, and it is simply bad cultivation that produces fruitless plants. No one need therefore be afraid to take young plants from their old ones to form young plantations, and this is a commendable way of securing them. When beds are allowed to get into a bad state they are apt to give the impression that it is no use taking young plants from them, but I would just as soon have young plants from a bed that had become unfruitful from inattention as from the most fertile plants. The successful fruiting of Strawberries does not depend on this, but on good culture, and without this no plants will prove really remunerative.

The excessively dry weather in June and July interfered to a great extent with the fruiting of Strawberries in many cases, but it has not hindered the formation and development of runners or young plants, for these are as plentiful and strong as I ever saw them, and there will be no difficulty in securing many for planting this autumn. There are various ways of preparing young plants. I have rooted hundreds of them in small pots, kept them in these for a time, and then planted out, excellent plants being produced in this way, but much labour attached to their treatment. An easier way is to cut a number of pieces of turf into small squares of about 3 inches in width and thickness, peg a runner on the top of each of these, allow it to root into the turf, and then it is ready for planting anywhere, as the roots are clustered in the turf and do not suffer from being moved. This is an excellent way of treating young Strawberry plants. Only the other day I began to layer some hundreds of them in this way, but soon found that the young plants were so freely rooted into the ordinary soil that it would be a mistake to disturb them by lifting them and trying to re-root them, so now lift them with fine balls of roots.

These may either be placed into 6-inch pots for fruiting, or planted in the open as a new plantation, and if those who are dealing with them would look and see if their plants are so well rooted as ours are, they would find it a very easy matter to secure any quantity of young plants in fine order. But it is of the utmost importance that they be secured with good balls of soil to the roots, and if this cannot be done, and they are lifted without any soil attached, the plants will make little or no progress this autumn, and it will be the year after next before they are sufficiently strong to bear anything like a crop. Having brought the young plant arrangement so far, attention must be turned to preparing the ground for their reception. This is work that must not be shirked or scrambled over. A heavy deep soil is very much better for Strawberries at all times, especially in a hot dry summer, than a shallow light material. Their success in the latter will only be partial and rather uncertain. Our new Strawberry plantation of 1887 will be in the heaviest soil in the garden. The ground in question was trenched and manured in spring, manured and sown with Peas. These have been cleared off. The soil is deeply dug again with more manure added, and it is now ready for the plants, but they will not be put out until it rains, if it should do so before the end of August, and if not then they will be planted and liberally watered—if we have any water—until they take hold of the soil.

It is not a good practice to plant Strawberries after Strawberries. Old beds are very apt to become weedy. If these are dug and

Strawberries planted again the weeds will soon reappear. This is injurious to a young plantation, and the ground should be thoroughly cleaned before any Strawberries are planted. In large gardens where there is plenty of ground the plants may be put in at a distance of 2½ feet from row to row, and 18 inches or 2 feet from plant to plant, but in small gardens they may be kept considerably closer, as although the wide planted ones may produce the largest fruit, the others will also bear very profitable and highly acceptable crops.—J. MUIR, *Margam*.

## THE ENGLISH ARBORICULTURAL SOCIETY.

### A VISIT TO RABY CASTLE.

THE necessity of an increased attention being paid to forestry and arboriculture generally in this country induced a few practical men to endeavour to form in this country a Society on a similar basis to that which has done such good work in Scotland during many years. The idea was favourably received, and four years since the English Arboricultural Society was organised to carry it into effect. With a number of patrons, a practical Committee, and an earnest Secretary, the Society has made good progress, its members have increased in numbers steadily, and it is still being strengthened by the addition of new friends. The Society has appointed local Secretaries in the principal northern districts who correspond with the Chief Secretary upon all matters of interest to the members, and they can summon meetings of the members in their respective localities to conduct any special business, or to be present at the reading of papers on various subjects connected with forestry. With a desire to encourage the latter mode of communication and to add something to the literature of the subject of practical value, a silver medal was offered last year for the best essay on "Larch Disease," an honour that was won by Mr. Clark of Carlisle. The essay was printed in the Transactions of the Society, which with several other papers, including one by Mr. B. Cowan of South Shields on "Trees and Shrubs for the Seaside and where Alkali and Gases are Prevalent," forms a substantial volume. Much more might be done in this direction, and frequent prizes or medals should be offered to the younger men engaged in arboriculture, as it is a method of advancing the scientific and practical knowledge of the art that is certain to produce satisfactory results. Great Britain is far behind several of the Continental countries in the education of foresters, and the result is that some of the best colonial or other appointments out of this country are secured by young Germans who have been well schooled in the theoretical as well as the practical departments. Some official recognition has been recently accorded to this matter in the House of Commons, and it is probable that further steps will be taken in which both the English and Scottish Societies should be able to render good service.

Another and very interesting portion of the Society's work is the arrangement of annual excursions to the seats of gentlemen in the north of England. It forms a pleasant meeting for the members, and much information can be often gained by the inspection of well kept woods and plantations under the guidance of experienced foresters. For the present year's trip Raby Castle was selected, and by permission of the Duke of Cleveland a large party of members and friends visited that estate on Thursday, August 18th. Those present included the following:—Mr. John Davidson (Secretary), land agent, Heydon Bridge; Mr. Isaac Baty, Hexham; Mr. Jas. Watt (of Little and Ballantine, nurserymen, Carlisle); Mr. W. F. Taylor, Carlisle; Mr. William Fell (of Messrs. Fell & Co.), Hexham; Mr. Wm. Milne (of Messrs. Fell & Co.), Hexham; Mr. J. R. Brown, nursery manager of Fell & Co.; Mr. John W. Robson, nurseryman, Hexham; Mr. John Balden, agent, Dilston; Mr. John Balden, jun., Dilston; Mr. Peter Balden, Dilston; Mr. R. R. Balden, forester, Castle Howard; Mr. John Wilson, superintendent Leazes Park, Newcastle; Mr. John Smith, forester, Langley Castle, Haydon Bridge; Mr. J. W. Newbigging, nurseryman (of Thomas Kennedy and Co.), Dumfries; Mr. John Johnston, assistant forester, Wetherby, Carlisle; Mr. M. Sutherland, nurseryman, Longtown; Mr. Sutherland, jun., Longtown; Mr. B. Cowan, superintendent, Westoe Cemetery, South Shields; Mr. Gallie, forester, Ravensworth Castle; Mr. Robinson, agent, Burnopfield; Mr. Havelock, forester, Raby Park; Mr. Lewis Castle (*Journal of Horticulture*), &c.

Most of the visitors assembled at the Central Station, Newcastle-on-Tyne, at 9 A.M., and proceeded thence at 9.30 to Gainford Station, on the Barnard Castle branch from Darlington, where vehicles were awaiting the visitors to convey them through the estate. The first portion visited was the Gainford Great Wood, and there some time was spent under the able guidance of the forester, Mr. Havelock, who gave some interesting particulars concerning the large plantation of Oaks, their value, the several cuttings of timber sold, and the young trees recently planted to fill the space cleared. It was said that the plantation was several hundred years of age, but that it was thought many of the trees now standing had sprung from the old stools, as well as those cut, which were 120 to 140 years old and realised about £300 per acre. Some of these Oaks were of remarkable size, some of the best examples being seen in the park, where also there are some grand Beeches, but at Gainford several unusually large and finely developed specimens of the common Ash were noted. Proceeding on the journey through a beautiful country commanding extensive views, the Staindrop lodge entrance was reached, and near there a young Turkey Oak was planted in commemoration of the Society's visit in the Jubilee year. Mr. Robson of Hexham supplied

the tree, and it was planted by Mr. J. Watt of Carlisle (Messrs. Little and Ballantyne), who made an appropriate speech, complimenting the Society upon their progress and work. Passing through the diversified and beautifully wooded park another plantation was visited, where some larger timber was seen, the dimensions of the more remarkable trees being taken. A considerable time was spent there, but a portion of the party also visited the garden, where so much of interest was found that the time only admitted a hurried inspection.

### RABY CASTLE GARDEN.

The garden is situated on a moderate slope to the south near the Castle, and comprises ten acres chiefly enclosed by walls, and comprising a number of glass houses devoted to plant and fruit culture. The houses are somewhat scattered, as they have been mostly erected at different periods, and not according to any set plan, so that now there are no less than sixteen boiler or flue fires to be attended. The garden is in perfect accordance with the Castle and its surroundings. No attempt is made to modernise the place, which would only spoil it, but in every department the able and courteous gardener, Mr. Westcott, shows us the best examples of cultural skill, while the flower garden also affords an admirable example of the charming effects produced by a tasteful arrangement of hardy plants. The latter department was so beautiful that it first attracted attention and merits a description. One pretty feature of the beds is that they are edged with neatly trimmed fresh green Box, and separated by narrow paths of fine gravel or sbringle kept evenly raked. In front of one range is a series of beds bounded on two sides by grand Yew hedges, 10 feet high and as much in diameter at the base, and in fine health. The age of these hedges is unknown, but it is thought they formed, with two magnificent old Walnut trees near them, a portion of an older garden occupying the same site many years ago. Very conspicuous are the beds of Raby Castle Carnation, a handsome rose-coloured variety that cannot be surpassed for bedding or cutting purposes. The flowers are of good size without being too large, they are of excellent form, full, the colour clear, and very fragrant; the plants also are strong and free growing, of moderate height, very floriferous, and the stock is readily increased, as an abundance of "grass" is produced. Masses of double white and purple Stocks, Godetia Lady Albemarle, white Pansies, and Zonal Pelargonium Henry Jacoby, to all of which beds are separately devoted, have a capital effect. Tuberous Begonias are much appreciated for outdoors, and some large beds of Laing's "Royal" varieties have a rich appearance now. A broad border devoted to miscellaneous plants has bands of Pentstemons very bright and varied, Sedum spectabile, the dark reddish-leaved *S. maximum*, and Anemone japonica, which contrast well together, Zinnias and Poppies being freely employed in other beds.

Just beyond is a handsome ribbon border, the background of which is formed by a remarkable hedge of Fuchsia Riccartoni, over 100 yards long, about 4 feet high, as much in diameter, and loaded with flowers. Owing to the dry season the plants are not quite so high as usual, but they are in excellent condition, so fresh and even that the effect is exceedingly beautiful, the appearance being still further improved by the hedge following the curve of the walk instead of being in a straight line. This Fuchsia dies down to the roots each winter, but these are never damaged by frost, and it has occupied its present position for twenty-one years, so that it has had an extensive trial. The border in front contains a broad band of Viola Blue Bell, margined with the variegated Alyssum and blue Lobelias, with a few pink and scarlet Pelargoniums in alternate circles, and edged with Box. On the other side of the path are circular and semicircular beds edged with Box, and containing some brightly coloured Violas, but the chief feature there is a new dwarf *Tropeolum* named Constantine, which is the finest scarlet bedding variety we have seen. It is very compact in habit, and the foliage is scarcely visible owing to the profusion of brilliant scarlet flowers produced, the glow of colour being dazzling on bright sunny days.

This path leads from the enclosed garden to a beautiful walk outside the walls, but above the ha ha, extending in a series of graceful curves to the wonderful old Fig tree, which occupies a house at the extremity. On the left hand side is a low light iron fence covered with Clematis Jackmanni now flowering profusely, while on the wall side is a ribbon border formed of Golden Feather Pyrethrum, scarlet Pelargoniums, Blue Bell Violas, May Queen variegated Pelargonium, Calceolarias, and background of Hollyhocks and Poppies. An excellent view of this border is obtained from the slopes leading up to the castle. Before quitting this department mention must be made of the fine plants of *Mina lobata* which are trained to the height of 10 feet against a wall with a southern aspect, and they are bearing a great number of spikes of tubular flowers, scarlet before they are fully expanded, and then becoming yellow or nearly white, so that the spikes show a transition between these extremes from the base to apex of the rather long one-sided spikes. Some attention has been drawn to this plant lately, but its beauty cannot be too highly estimated where it will succeed as it does at Raby, for the deeply divided leaves have also a good appearance.

The principal range of glass contains the vineries; this is 160 feet long in four divisions, including the celebrated house where the carriage border was formed some years ago, and concerning which so much has been written. In the end division are some vigorous twelve-year-old Vines, Black Hamburgs being extremely fine, the bunches large and well coloured; a rod of Madresfield Court worked on a Black Hamburg stock, fifteen fine bunches, colouring well without a sign of cracking. The

adjoining division is the notorious vinery, and there we find that handsome variety, Duke of Buccleuch, in capital form, one Vine bearing twenty large bunches, the berries large, very clear, and colouring well. Mr. Westcott considers one of the secrets of success with this variety is liberal ventilation, and he evidently experiences no difficulty in obtaining the Grape as its admirers like to see it, and when in such condition it is undoubtedly a magnificent fruit. Lady Downe's, Muscat Hamburgh, and Gros Colman are very satisfactory in the same house. The third vinery is mainly devoted to Muscat of Alexandria, of which there are some grandly coloured bunches. Mrs. Pearson and Golden Champion are also bearing a good crop of fine bunches, colouring admirably. The Vines here are about twenty years old, but the year before last they were lifted and replanted, the result being that the Vines have been greatly invigorated, as the fine crops testify. The fourth house is occupied with young Vines recently planted, which are making good progress, but the most notable occupants of this house are some plants of *Vitis heterophylla variegata* and *humulifolia*, which are trained on trellises for room decoration, the spaces between being filled with *Thunbergias* when they are wanted for use. There are several early vineries, Peach houses, &c.; but another important feature at Raby are the Pine Apples, of which 300 are grown of Charlotte Rothschild, Smooth and Prickly Cayenne, and Queens, of which there are some fine fruiting and succession plants. Melons

Anthuriums, Crotons, Statice, &c., which frequently figure prominently at local shows. *Calanthe Veitchei* and *vestita* are well grown, eight fine baskets being filled with strong plants, the pseudo-bulbs of great size, and last year spikes 4 or 5 feet long were obtained. In the stove with the plants just named is *Peristeria elata* with two spikes, one with nineteen flowers and buds. Golden Allamandas on the roof and the graceful *Asparagus plumosus* are notable in the same house. *Lapagerias* are very fine in the greenhouse, the red and white varieties being planted together and trained on the roof, the stems twining about one another, and produce a charming effect, the red and white wax-like flowers hanging together most gracefully in festoons. The plants will soon cover a large house, for they seem to thrive well in a bricked border of peat and charcoal with good drainage, about 4 feet square and 2 feet deep. An ornamental conservatory near the flower beds first mentioned contains plants of the bright *Canna iridiflora*, *Araucaria excelsa*, and *Camellias*, with *Bougainvillea glabra*, *Swainsonia galegifolia alba*, and *Tacsonia Van Volxemi* on the roof, and a huge plant of *Brugmansia suaveolens* at the end, its great trumpet-shaped white flowers perfuming the whole house. Large quantities of small plants for decoration are grown, and Cockscombs are cultivated very successfully, being dwarf and bearing large well-formed richly coloured "heads." The kitchen garden, like all the other departments, is

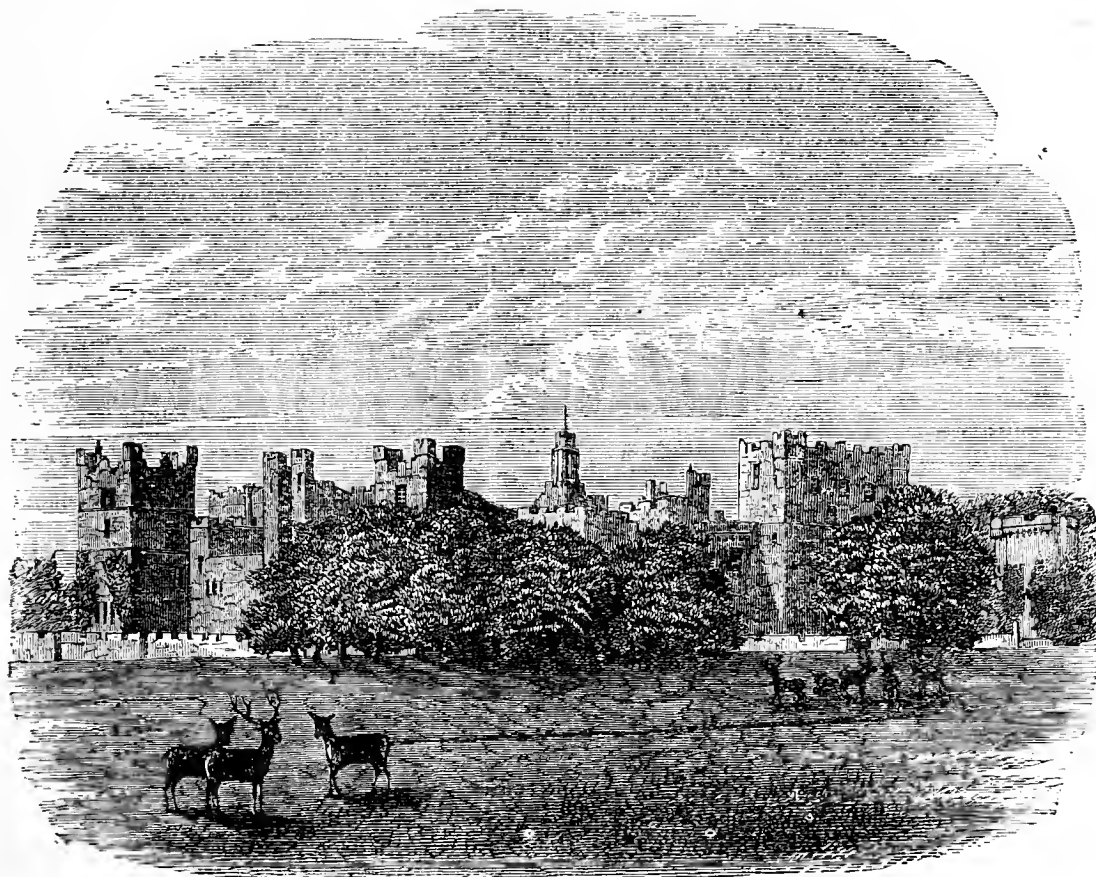

Fig. 19.—RABY CASTLE.

are in large demand, and a supply is obtained from plants in pots up to Christmas, Best of All being the favourite variety, about two good fruits being taken from each plant. In a late Peach house are healthy trees of Royal George, Walburton Admirable, Barrington, and Bellegarde Peaches, with Pitmaston Orange, Rivers' Orange, and Pine Apple Nectarines, which are the favourite varieties, and all are bearing capital crops. Some of the trees are of great age, and one of Pitmaston Orange has its stem four or five times the diameter of the stock. A tree of Royal George is also interesting, as, though the stem is quite hollow and the only living portion is the shell-like outer wood and bark, the stem above being also strangely twisted and distorted, it is in perfect health, the foliage fresh, the fruits numerous and well developed. The old Fig tree already mentioned is an extraordinary specimen of the White Marseilles or Raby Castle, filling a lean-to house 50 feet long, covering both the back wall and the roof. It is said to be over 100 years old, and bears a large quantity of fruit. Apricots are much valued at Raby, and, despite the disease, they are successfully grown, especially some fine trees against a hollow wall heated by flues, where some grand fruits are obtained, never losing a crop, and the flavour is excellent. The trees have, however, been twice renewed in twenty-two years, and Mr. Westcott finds that generally Moorpark is more subject to the disease than other varieties, though there is one striking exception to this in a tree of that variety that is probably fifty years old, and is in perfect health without a sign of defect. Outdoor fruits, such as Apples and Pears, are fairly good crops, some varieties of the former especially.

The plant houses contain several good specimen plants, such as

admirably managed, and the condition of the whole garden reflects the highest credit on the genial superintendent.

Before leaving Raby the visitors inspected the principal rooms in the Castle, a grand old historical building, from the terrace of which a charming view of the park is obtained, the prospect being bounded by a fine belt of timber, and the undulating surface of the park is rendered still more picturesque by the large number of deer with which it is stocked, the appearance of the stately Castle being enhanced by the rich green Ivy that is gradually clothing its massive walls. Within a mile of the Castle is the quaint old village of Staindrop, with an interesting church containing many fine monuments of the Neville and Vane families. Some time was spent there, and then after dining together, the party departed for Winston station about 6 P.M., having spent a most enjoyable day.—L. CASTLE.

#### STRAWBERRIES.

SOME few weeks ago a correspondent wrote complaining of the flavour of some varieties, particularly Loxford Hall Seedling. I think the very hot weather which dried the moisture out of the ground had something to do with the poor flavour in Strawberries this year. I have sometimes noticed that Strawberries in pots have been allowed to get dry enough for the foliage to droop, and although they have been well watered afterwards, the flavour has not been equal to those which have never suffered by want of water. On the other hand, when Strawberries have too much water and not much sun they are equally



bad in flavour. Those varieties which have the most foliage seem to have stood the dry weather best this summer; no doubt the leaves sheltered the fruit from the fierce rays of the sun. Last August we planted Loxford Hall for the first time, the plants grew well, and they gave us a better crop of fruit than any other variety the first year of planting; the flavour was good, but not quite equal to Dr. Hogg, or Vicomtesse Hericart de Thury. With us Pauline is the best early out doors, and an excellent forcer. The next best are La Grosse Sucrée, Vicomtesse Hericart de Thury, President, Sir J. Paxton, Dr. Hogg, and Loxford Hall. We grow several other sorts, but these we consider our best for quality, quantity, and size combined.—J. L. B.

### GOOD MUSHROOM CULTURE.

Of all the dainty vegetables with which a good gardener furnishes the kitchen high up stands the Mushroom. Such is the constant demand for this dainty from November to May, that it generally causes no little anxiety beforehand with many gardeners for fear there should be any mistake in proceedings, for it is possible for the very best cultivators to fail, although such is seldom the case. Where there is much winter cooking carried out of course the head cook is a somewhat important personage, and if a failure in Mushrooms should by chance occur in early winter these people are fearful to meet—better, as Solomon says, “meet a bear robbed of its whelps.” And no marvel either, when we take into consideration the various forms it may be made to assume in cookery, even in its full character, to say nothing of the spice of flavouring it is capable of imparting when in judicious hands. Let but a gardener have constantly plenty of Mushrooms, Seakale, and forced Asparagus—all good—through the winter and spring, and he will pass muster, although, perhaps, no genius. Now much has been written about Mushrooms. Still I believe that a paper or two annually will do good to some, although it simply warms up and freshens the first principles of culture.

Instead, however, of following the beaten track of detail I will endeavour to discuss a few main principles on which their culture depends. I think that we may just raise questions as follows:—Character of dung, should it be fermented? What about moisture? Does it need admixture? Should the bed be loose? What about spawning, and also soiling? These are the points I will attempt to ventilate. I do really think that there is one class of minds—and I am not sure they are in a great majority—that would sooner fall in with good practice by such analysis than by complication of mere dry rules, which are frequently conventional, and can never carry that powerful conviction to the mind that real principles truthfully handled can do. However, all this depends on the previous cultivation the mind has received, and, by consequence its real weight and position. I will take the points consecutively.

**CHARACTER OF DUNG.**—Nothing can exceed good horse dung for Mushroom beds, although they may be produced from other manures, and even from simple vegetable matters. The dung should be from horses well fed, and obtained, if possible, before a drop of rain has fallen upon it. The longest of the litter may be rejected, and the material when shaken out should contain a deal of droppings.

**SHOULD IT BE FERMENTED?**—There has been, and still continues, much misconception on this point. I will not go so far as to assert that fermentation is never requisite; but this I know, that if the dung is quite fresh, as it ought to be, and never receives rain, that a week or two of drying under some shed are all that is needed. Now the dung must not be wet when made into a bed, neither may it be dry—it should be slightly moist. I believe that the only moisture that requires to be evaporated is the urine. This in the main dissipated, the spawn will at once revel in the manure. I should much like to know what some of our practical men have to say on this matter. The fact is the urine is either a foe to the Mushroom, or it is not. I presume the former, but dare not insist on it. A few facts with which most of us have been familiar since our laddish days seem to favour the impression. I have seen Mushrooms springing freely from the floor of a deserted stable where the droppings had fallen, but not until the lapse of many weeks, during which period I apprehend that as the urine of the horses evaporated, the rest in proportion generated spawn, and finally produced Mushrooms. I have also repeatedly seen in the stable of a neglectful carter, who, instead of removing the droppings daily, economised them by sweeping them into a sly corner of the stable—I have seen excellent Mushrooms springing from such a heap, but let it be remembered it was always about July or August. Now we all know that there is something almost mysterious about the production of Mushrooms, albeit we gardeners can make sure of a crop in general, and indeed there is as much room for inquiry and a free interchange of opinion in this matter as in any one thing in the world of gardening. The ordinary impression is and has been that the air during summer is charged with the spores of this singular vegetable, and that when it alights on any body congenial to the production of spawn, it succeeds, all other conditions being equal.

**MOISTURE OF DUNG.**—The remarks requisite on this head having been involved in the preceding, little remains to be said. Dry dung will not succeed, and very moist is unfavourable to the working of the spawn; so, then, it must be in a medium state. We all know that to have a Mushroom summer out of doors we must have much dry and warm weather in May and June—the period when the spawn is spreading, which, indeed, constitutes a period altogether distinct from the production of Mushrooms. But when the spawn has established itself, mainly in dryish conditions, then the country people long for a warm shower or two at the end of August to bring out the Mushrooms: the spawn-breeding period therefore requires rather dry conditions; the Mushroom-producing period slightly the reverse. Fogs at night and heavy dews are noted in the early part of September for bringing the Mushrooms out in the fields. In all these cases and conditions we must never cease to imitate such, and this has led me in the present case to talk of principles rather than rules.

**MIXTURES.**—In former days the old Mushroom growers about London who produced for the market used nothing but dung—no soil, but then their beds were those outdoor ridges which were in the main an autumn and early winter affair. No sooner, however, did Oldaker show forth a Mushroom house than Mushroom growing underwent a kind of revolution. People began to see that it was neither a matter of position nor shape nor make in the beds, and that they might be grown readily in a garden pot or box, or, indeed, any vessel. But it was also discovered that the shelf affair, only permitting dung about 7 inches in depth, was but a matter as to durability. This led people to mix loam or soil with their manure. Indeed, this is the way in which spawn is made; and I have always found that the more fibrous loam could be mixed with the dung the longer such spawn would preserve its vitality. Now it is evident that the nearer a Mushroom bed approaches a good spawn brick in consistence and solidity the better. And here I may observe that there is a trickery in spawn as in other things. It is the fashion now-a-days to use nearly all flaky dung; and why? Because it dries quicker, is sooner in the market, and gives less trouble. But there is no comparison between this chaffy spawn and that made by a due admixture of loam or other soily material. The quickly made spawn of dung will not endure the least steam in the dung of the bed; it will sometimes rot in three days, and this I think because dung is so rapidly absorbent as compared with sturdy loams. I have already pointed to the necessity for firmness in the beds; they cannot, indeed, be too firmly beaten.

**SPAWNING.**—This, too, is half discussed in the foregoing, but a few words are necessary. The greatest danger to be apprehended, admitting that the beds are right as to dung, &c., is from overheating. In all cases, when beds are made of fermenting materials, the heat will rise gradually to what we may call a culminating point; and that, once attained, as gradual a descent takes place. The highest point should never exceed 80° if possible; and when it has descended fairly to 65° or 70°, then may the spawn be introduced with safety. Under such circumstances good spawn in good dung will begin to spread in a week or so. If it does not spread quickly it is not quite in earnest; and the best way is, with a slight amount of jealousy, to open new holes and spawn the bed again. As for soiling, it is not so very material a point, 2 inches of good loam slightly adhesive is the best. If, however, any amateur cannot obtain the gardener's fancy loam, let him not despair, but use some good garden soil; never mind what peculiar tint it is, only let the soil be pressed or beaten firmly.

I may now indulge in a few remarks of a miscellaneous character bearing on the Mushroom in some shape. First, as to watering beds if very dry. It is no uncommon practice to sprinkle dung slightly before it is made into beds; but in this case the dung should lay in a body for a day or two previous to building the bed. I would never sprinkle it while building if possible. I have generally found it good practice to sprinkle the beds slightly with lukewarm water after they have been made about a month or five weeks; in fact, just before the Mushrooms are expected through. The soil generally becomes slightly husky, and a little water greatly facilitates the production of the Mushroom. But this is meant simply to moisten the soil; for bed or dung moisture we must ever depend on the character of the dung at the time of making the bed. Sometimes it has happened that the dung has got too wet with rains—this is awkward. I have tried in this case a strong fomentation, but it seldom succeeds well as a drier of the dung; for by the time the water is dissipated by heat, the manure is so decomposed as to be more fit to dig in for Celery than for Mushrooms. I have tried wrapping the lumps of spawn in dry strawy material in such cases in order to protect it against excessive moisture, but here I have been astonished, years since, at finding the spawn as entire after a couple of months as when introduced, but yet unable to break through the strawy prison which becomes encrusted.

**ATMOSPHERIC CONDITIONS IN MUSHROOM SHEDS OR HOUSES.**—These are deserving particular notice. It is a well-known fact that

Mushrooms will not endure very high temperatures indoors, and certainly not aridity of air. I think 60° should ever be the maximum point; but anywhere between 50° and 60° is congenial to them. The air should be kept continually moist by water application while firing is used: in other cases more moderation may be used. Well, then, as to air-giving. It surely needs little argument to prove that they do not like a corrupt air, when we consider how boldly they spring forth at the end of August in our fields, where they have the comfort of a puff of wind occasionally, so that we may rely upon it they love fresh and sweet air. Indeed, it is this that completes their flavour. I am well assured that however delicate and nice our artificially grown Mushrooms may be, they will never make such rich catsup as those from the open fields. Those who grow them on the old-fashioned ridge beds out of doors—a plan well adapted to produce up to the beginning of winter—should beware of the strawy covering. When the weather becomes severe in November people are induced to lay on an extra covering, and this is apt to ferment. In so doing the surface of the bed will generally be clothed with a profusion of spawn instead of Mushrooms, and this rapidly lays hold of the strawy covering. I have known many a good bed spoiled in this way. The only cure for this matter is to place clean, dry straw next in contact with the bed; over that what you please.—E. N. R.



#### DISA GRANDIFLORA.

THE best time to repot this plant is just as new growths are pushing from the base—these quickly take, appearing after the flower stems are cut down. If the operation is delayed too long the fresh roots which have been made will be broken to some extent. This must be avoided, for it checks the plants, the growth and flower spikes being smaller in consequence the following year. At one time we repotted these plants annually after flowering, and found that the practice was necessary to maintain sweet material about the roots. We used at that time living sphagnum moss to the extent of one-third amongst the compost, and found that it was thoroughly decayed in twelve months. This method of culture has been discontinued, and repotting done less frequently. For some time now half the stock has been potted in peat fibre, and the remainder in the fibre extracted from turf that has been stacked for some months to destroy the grass. In each case all the soil is shaken out of it, and nothing that will turn sour or go close left in. With this charcoal in lumps is freely used; and a little living moss placed only on the surface, which is removed every spring and replaced with fresh. We have found but little difference in the lasting properties of the two fibres, and the plants do equally well in either. If the fibre is good, and no fine used amongst it, cutting will not be necessary oftener than every third year. With a sweet open compost of this nature liberal supplies of water can be given without fear of the compost becoming sour. When potting is done all the old material should be removed, and the pots or pans thoroughly washed, as well as the drainage.—C. V. R.

#### COOL ORCHIDS.

THIS has been a trying season for *Odontoglossums* and other Orchids that grow in the same structure with them, for it has been difficult to maintain either the day or night temperature near the mark that many cultivators think should not be exceeded. Our temperatures, and I daresay the majority have, has been considerably higher, and more air has been given than on any occasion since we commenced cultivating them. Yet the plants never looked better or possessed sturdier growth. One would naturally have expected after such hot weather that the plants would have grown rapidly and their foliage drawn up weakly, but this is not their condition. Although the temperature has been higher, the same blinds as on previous occasions have been used, consequently a greater abundance of light has reached the plants. The foliage presents that dark brown or red appearance that lovers of these plants so much desire to see. If the experience of a season like the present teaches one thing more than another, it is, that we are too apt to over-shade these plants. There can be no doubt whatever that they dislike, and cannot endure, the strong rays of the sun, but at the same time their condition at the present time would lead one to believe that they are too frequently overshaded.

For two or three years I have been watching a collection that is grown in a house with a northern aspect—I mean behind a north wall—and they always present the very picture of health. A few

days ago they were as green as Lceks, if the term may be used. How do they flower? After watching them closely I should say very unsatisfactorily indeed. They never produce such fine flowers or stiff sturdy flower spikes, or in such quantity, as the plants in my house, that always had since they were imported a much lighter position; in fact the house in which they are grown runs east and west, so that they are bound to get a fair share of sun and light. I do not know that I should prefer this position, but the house was erected, and we have no alternative; but if any preference was given it would be for a structure running north and south. It would be very interesting and instructive to know how these plants in other gardens have grown and flowered when kept the whole year round in houses with a northern aspect.—S. L.

#### MOISTURE FOR ORCHIDS.

SEASONS like the present show the absurdity of erecting houses for these plants without providing abundant provision for moisture. In many houses this is the one great drawback to the successful culture of Orchids. In ordinary houses, with flagged floors and the side beds built of brick, the little water that can be applied quickly evaporates. In such structures, unless a man is constantly damping the available places in the house and amongst the plants, the air becomes too dry for the well-being of the plants. Flagged or cemented floors may be provided, for they are the cleanest and best to walk upon, but channels on either side should be provided to hold a good supply of water. Beneath the beds or stages the base should be formed of earth, or, better still, small peat or cocoa-nut fibre refuse, so that abundance of moisture can be retained without much trouble. When such provision is made open lattice stages are just as good, in fact better than slate, that will only hold 1 or 2 inches at the most of gravel or other moisture-holding material. A good depth of fine peat or cocoa-nut fibre refuse below open stages when thoroughly saturated insures a constant supply of moisture rising amongst the plants without the constant trouble and expensive system of continually damping the houses.

Economy in labour at the present time has to be considered, and this must be fully arranged for before houses are constructed for various purposes. Neat well-finished houses internally are not always the best and most suitable in which to cultivate plants, especially cool Orchids. The first consideration should be to construct the house so that a bountiful supply of moisture can be maintained with as little labour as possible. Providing plenty of air and moisture can be given, *Odontoglossums* are not so particular about the temperature ranging a little too high if a corresponding amount of light is admitted to them. When the conditions for luxuriant growth are favourable and plenty of moisture maintained yellow thrips seldom trouble the plants, but these insects are often ruinous when the atmosphere is comparatively dry.—N. G.

#### ROYAL HORTICULTURAL SOCIETY.

AUGUST 23RD.

THE conservatory at South Kensington was unusually well furnished on this occasion in consequence of the "co-operative" show of garden produce by cottagers and others. The collections occupied a table extending the entire length of the building, and was furnished with vegetables and hardy fruits highly creditable to the several cultivators, brightened with bouquets and stands of cut flowers. It is unquestionably most desirable to encourage high culture in the gardens of the industrial classes, but how far it is wise for the Council of the Royal Horticultural Society to offer their medals for produce grown by seeds of a particular association exclusively is a moot question. Possibly the Council were not fully cognisant of the interesting stipulation. It was not mentioned in the paragraphs that were sent by the managers to the public press, but it is clearly stated in the schedule that the produce must be grown from certain specified seeds.

The side tables were furnished with representative collections from several nurserymen and florists. Mr. T. S. Ware staged *Gladioli*, Iceland Poppies, *Montbretias*, *Liliums*, and a very fine stand of *Gaillardia* blooms, one variety being certificated. Mr. Ware had also stands of double and single *Dahlias*, one of which, a very bright single variety, Mrs. Jordan, was certificated.

Messrs. Jas. Veitch & Sons staged a miscellaneous collection of plants, in which greenhouse *Rhododendrons* were prominent; some pans and pots of *Omphismenus albidus* attracted attention by the extreme dwarfness of the nearly white *Panicum*-like plants (a vote of thanks). A similar mark of recognition was accorded to *Senecio macranthus*. It has large palmate leaves and yellow flowers about 3 inches in diameter, with thinly disposed florets, the stems 3 feet high; this is said to be the first time this species has flowered in this country. It is a native of China. The same firm also exhibited a new *Asplenium* referred to below.

Messrs. H. Cannell & Sons, Swanley, had stands of large fine symmetrical blooms of show *Dahlias*. A splendid group of *Lilium auratum*, comprising about a hundred plants, was staged by Mr. W. Gordon, Twickenham, many of the blooms being of great size. Messrs. Kelway & Sons had a grand display of *Gladioli*, 150 spikes in splendid old and new varieties, several of the latter being honoured with certificates. Bouquet *Aster* *Pyramidal Rose* from Messrs. Vilmorin, Andrieux & Co. was commended for the character of the strain. The plant was very floriferous, flowers medium size and rosy pink in colour.

Of the above collections a silver-gilt Banksian medal was recommended

to Messrs. Kelway & Sons, and silver Banksians to Messrs. Cannell, Mr. Gordon, and Mr. Ware.

**FRUIT COMMITTEE.**—T. F. Rivers, Esq., in the chair. Present:—Messrs. Warren, Willard, Lee, Rutland, Norman, Fitt, Bunyard, Pearson, Crowley, Burnett, Blackmore, and Dr. Hogg. Mr. Miller, gardener, Rood Ashton, Trowbridge, sent a seedling Melon called Rood Ashton Hybrid, raised from a cross between Scarlet Premier and Cashmere. It was possessed of very good flavour, but it was not better than others already in cultivation. The same may be said of another variety without a name shown by Mr. William Palmer, The Gardens, Thames Ditton House. Mr. William Taylor, Hampton, sent dishes of Early Harvest and Dutch Codlin Apples.

Messrs. James Veitch & Sons exhibited twelve Plums and Peaches in pots well supplied with excellent fruits, and also twenty-seven dishes of various fruits, to which a vote of thanks was awarded.

**FLORAL COMMITTEE.**—George F. Wilson, Esq., F.R.S., in the chair; also present Messrs. Hill, O'Brien, Pollett, Ballantyne, G. Paul, Noble, Walker, Fraser, Wilks, Douglas, Lendy, Baines, Holmes, Hibberd, H. Turner, and Dr. Masters. The following plants were certificated:—

*Asplenium scandens* (Veitch).—Fronde upwards of a foot long, borne on a long rhizome, deeply cut and very elegant, it will make a fine basket Fern. A native of Sumatra.

*Cypripedium praestans* (Linden).—A small plant but vigorous; possessing somewhat of the character of *C. Stonei*; top and bottom sepals clearly striped or barred with maroon on a light ground; tails spotted, drooping, 4 to 5 inches long, and twisted. It was introduced from New Guinea, and is said to be the first from that region. The small spike had two flowers and a bud; and with strength there is little doubt that several flowers will be borne on a stem.

*Dahlia Miss Gordon* (Ware).—Flower round, with smooth overlapping florets, bright crimson in colour, the lower half clear orange, very bright.

*Gaillardia Admiration* (Ware).—Very large, with broad florets, clear yellow, with a crimson base.

*Scolopendrium crispum fimbriatum* (Stansfield).—A strong plant with large thick fronds, deeply cut, and beautifully fringed.

**Gladioli.**—All the following certificated varieties were exhibited by Messrs. Kelway:—*John Dominy*.—Flesh tinted and delicately streaked with rose, large and smooth. *Halle*.—Very large, soft scarlet, veined carmine, dark throat. *Mary Anderson*.—Large blooms, of a lovely mauve colour, a white stripe on each petal and white throat. *Mrs. Edgar Wild*.—A massive spike of large blooms, French white, heavily flaked with rosy carmine; and *Bonavia*.—Very large indeed, mauve, freely flaked with dark rose. Elton.—Rich scarlet, faintly tinted with maroon. Sullivan.—Coppery crimson, with a velvety blotch in lower petal, the parentage of *Lemoinei* being apparent in the character of the flowers. Paget.—Large open flower, salmon veined with red. Stanley.—Very clear scarlet, white blotch on lower petal and dark throat. Frank Miles.—Deep salmon heavily flaked with crimson.

A botanical certificate was awarded to *Disa cornuta*, exhibited by Mr. G. W. Cummins, gardener to A. H. Smee, Esq., The Grange, Hackbridge.

### SEASONABLE NOTES ON HARDY PLANTS.

THE recent deluge of rain has placed many things in the garden on a very different footing to what they were prior to the storm, and much work so requisite at this season of the year can now be energetically done. For example, any clumps of *Lilium candidum* that are deteriorating in strength, and that appear to need fresh nourishment, should be seen to without delay. Consequent upon the excessive and continued drought this Lily has been dormant longer than usual this summer; in fact it died off very quickly after flowering. Now that rain has come it will quickly commence root-action, and any new plantations which are destined to be made should be speedily taken in hand. Like all other members of its genus this species cannot endure constant removal, so that the deep planting is advised—that is, plant the bulbs 6 or 8 inches deep, allowing plenty of room for their increase in deeply worked and well-manured ground.

The nemorosa section of Anemones should be examined. In these for convenience I will include *trifoliata* and *Robinsonia*. All such as these having a rhizomatous root-stock are not calculated to endure the periodical drying-off process, so liberally bestowed on such kinds as *A. fulgens*, *hortensis*, *coronaria*, and the like, so that all the former should receive attention if requisite; the same remark applies to several species of *Crocus*, which will be seen making fresh roots.

*Chionodoxa Lucilia* and *C. sardensis* are now in splendid form for removal. Only the other day I moved a large bed containing many hundreds of bulbs. These had occupied one position for three seasons, and consequently had made some fine bulbs. Other things in the bulbous line are *Erythroniums*, *Seillas*, *Narcissus*, to which the same remark applies. Then we have to consider English and Spanish Iris, which, while keeping capitally in the beds or borders, seem to soon become affected with a dry rot if they are kept out of the ground for any length of time. I mention this fact that those about ordering them may do so soon, and when they come to hand plant at once, and also to warn those who are about lifting old stocks to plant them again as speedily as possible.—J. H. E.

### TRANSIT OF FRUIT AND FLOWERS.

OF late years we have frequently had the best of advice as how to pack fruits and flowers, and probably no one has written more explicitly in details than Mr. Bardney, and such corresponds well with our earliest recollections of our business connections with Covent Garden, where packing by the salesmen there has always been a speciality. Our latest observations there last season are

much as they were when we had lessons from Mr. Garcia about thirty years ago. However, it is not necessary to criticise methods of packing, but to refer to the mischief often done to fruit in transit. Extensive growers for market have arrangements with railway companies to exercise special care with fruit and flowers, and have them met at the railway terminus and conveyed to market with safety. With private growers it is generally different, the quantities being small, and left in the hands of railway servants. When a trans-shipment takes place it is then one sees the rough handling which goods undergo, and loose inferior packing is tested to the utmost. Baskets and boxes placed endwise or upside down is common enough, to say nothing of the jolting to goods when thrown from the goods vans.

Years ago, when we competed somewhat extensively, we often had our patience severely tried by the rough-and-ready transit of produce, which induced us to adopt means which in a great measure prevented coarse handling of the parcels—simply tying three or four boxes on the top of each other. The largest is at the bottom, and each is narrower and shorter as the pile is formed upwards, which effectually prevents the placing of it on either ends, sides, or tops, but on the bottom only, and the parcel cannot be with impunity thrown about carelessly.

Having to send large quantities comparatively of fruits, flowers, and vegetables long distances by rail, and sometimes by water, as well as overland transit by horse conveyances, we have to use the best means under our control to insure safety. From Edinburgh, Glasgow, or any station where there is through carriage to London, matters invariably go well, but when they first go by cart, then by a junction line of rails, then changing, perhaps to the Highlands, Ireland, or crossing to the Continent (as is sometimes the case) it is then that extreme care in packing is called into requisition. The usual notices in red ink of "This side up," "Care," &c., are of no avail when goods are moved and replaced by men under high pressure for time. We have seen the various boxes of produce placed securely in one large square hamper, and a peep into the van showed that it was placed in the most convenient manner to monopolise as little space as possible by being stood on its end.

We notice that undue wetting of flowers is often practised, to the destruction of many of them, and market people fall frequently into this error as well as others. Instead of drenching the flowers, we have found that when they are in a close airtight box, it is enough to moisten slightly the green leaves, which are placed generally under the flowers in a compact layer, and enough is emitted to keep the flowers fresh. Sending by night train to London or other long distances is a judicious practice.—A SCOT.

### INDIAN EXPERIENCES.

(Continued from page 89.)

BEFORE entering upon my remarks on the Neilgherry Hills proper, I may be permitted to say a few words on a famous valley, which, if not forming part of the plateau of the Neilgherry range, is situated at the foot of its north-western slopes and within its jurisdiction. The Coffee tree has been cultivated in this valley since the year 1842, and has always had a wide-spread reputation of being by far the finest Coffee-producing district of southern India. This tract is called the "Auchterlony" Valley, from the fact that in 1842 the late Mr. James Auchterlony, then a member of the Madras Civil Service, obtained from the Rajah of Nellumboor (who was at that time in possession of a vast extent of country lying at the base of the west and north-western slopes of the Neilgherries) some forty square miles of this valley, portions of which he subsequently resold for the purpose of Coffee planting, the remainder being cultivated by himself. The history of Coffee planting in this wonderful and delightful valley of South India, from the year 1842 to the present time is, I venture to think, a deeply interesting one, as illustrating the sad fact of how tracts of magnificent and fertile virgin land may be permanently ruined from the combined influences of mismanagement, want of knowledge of the first principles of agriculture, and the thirst for immediate gain.

As stated above the valley lies at the foot of the north-western slopes of the Neilgherry Mountains, and is surrounded on two sides by precipitous hornblende gneiss rocks, the detrition of which in the course of ages has formed in the valley below a soil of wonderful depth and richness. The elevation above the sea of this valley ranges from about 3500 feet to 4250 feet. The climate is therefore much more cool and agreeable than that of the neighbouring district of Wynaad. The rainfall, too, is very moderate, not exceeding perhaps an average of 75 inches per annum. With all these advantages therefore it is not surprising to find that the yield of Coffee for some years after the purchase of the tract by Mr. Auchterlony frequently reached the enormous figure of 20 cwts. per acre, and this without manuring or any cultivation save the keeping of the plantations as clear of weeds as possible, and pruning in a variety of ways according to the caprice of the various superintendents. Some 4000 acres of the valley are at the present time under cultivation of Coffee in the hands of the Auchterlony family, while other large areas are cultivated by others who had the good fortune to obtain land



from the original purchaser. For twenty-five years at least this valley yielded excellent crops of Coffee on an average, notwithstanding the unscientific and wasteful system that was adopted throughout the whole of that period, so deep and fertile was the soil worked upon and so favourable the climate. But a time came at last when the Coffee tree began to show signs of loss of vigour and the want of something more in the way of support than merely the natural food to be found in the soil of the valley. The taking of larger crops of Coffee than the trees could well support, the absence of systematic cultivation, and the varied and haphazard style of pruning adopted told their tale at last, and aroused the proprietors of the several properties to a sense of the absolute necessity of employing men trained in the art and practice of horticulture, and the adoption of measures having for their object a more rational system of cultivation, with a view to retrieving their fast-decaying fortunes. But all this was found to be too late; the evil had taken too deep a hold to be eradicated, with the consequence that, notwithstanding the expenditure of vast amounts of money and well-directed energy, the Coffee properties in the once-famous valley have for a number of years been gradually decreasing in yield of berry and value, till at the present time considerable tracts of land, once covered with a mantle of magnificent Coffee bushes, have been planted with Tea and Chinchona.

It would be difficult to exaggerate the financial benefits that might have accrued to the proprietors of this particular portion of the Coffee districts of South India, if, from the first opening of the plantations, they had procured the services of well trained gardeners from England, say men of a certain age and experience, as superintendents, and younger men to work under them. This common-sense view of the matter, however, does not appear to have occurred to them, and men were engaged to perform the work of planting, and subsequent so-called cultivation, utterly ignorant of the first principles of agriculture or horticulture. My first visit to the Valley was about the year 1864, on my way to Ootacamund. I stayed a few days in the neighbourhood with a friend, and had a good opportunity afforded me of visiting the different estates, and of seeing the various modes of pruning and cultivation being carried out at that time. I found that the late Mr. Auchterlony had then, as general manager of his properties, an ex-captain of a Peninsular and Oriental Steam Company's ship, with his fifth officer as an assistant, whilst the resident superintendents of the different plantations included not a single gardener or person in the slightest degree trained to, or in the possession of the faintest degree, of any kind of knowledge relating to the cultivation of the land. These last individuals were made up of clerks, sailors, carpenters, ex-army officers and sergeants, doctors, and others of various professions. These men seemed to adopt styles of pruning and cultivation according to their various fancies, and not from any general rules set down by the manager. It was no surprise, therefore, to find one plantation so pruned as to appear, from a little distance, very much like a brown grass hill, so ruthlessly were the unfortunate Coffee trees deprived of their branches, whilst on an adjoining estate the wood left on the trees produced a tangled mass to the entire exclusion of light and air. Some had the ground dug between the rows of trees to a depth of 6 or 8 inches during the height of the dry season, destroying innumerable fibrous roots in the process of turning over the huge clods, whilst others disturbed not the soil from one year's end to another. Some buried the weeds in pits dug between the lines of the Coffee plants several times a year as they were hoed up, whilst others never buried them at all, but left them on the surface of the ground to die. Some disbudded, or handled, as it was called, heavily during the rains, whilst others handled not at all, but performed the one yearly act of pruning with the knife during the dry season. Some there were who placed bone and other artificial manures at the rate of a half cocoa-nut-shellful to each plant close around its stem, whilst others placed it further out, or where the feeders of the Coffee tree would be more likely to find it, and thus the work went on with the frequent change of superintendents introducing new systems, if they deserved the name, till, as I have already said, the trees began to tire of such treatment, grow sickly, and eventually give up bearing to a considerable extent. In a letter from a friend dated January of this year, I am informed that the crop of Coffee just picked from the 4000 acres in the hands of the Auchterlony family only amounted to 350 tons, or 1½ ewt. per acre; so that allowing the moderate sum of 30,000rs. or £3000 on account of working expenses for the year, and 21,000rs., or £2100, for value of crop, this leaves a deficit of 9000rs., or £900 on the year's labour, and there seems to be no probability of the planter in this valley ever being able to reverse this state of things in the future, no matter how high and liberal the cultivation may be that is adopted, seeing that the *Hemileia vastatrix*, or leaf disease, is now added to the long list of evils to which the unfortunate Coffee shrub has been subjected.—PLANTER.

### THE DEVON ROSERIES, TORQUAY.

No rosarian would, and no visitor should leave Torquay without a call on Messrs. Curtis & Sanford. In a place where the Eucalyptus smiles at the winter, and tree Myrtles in full flower are now adorning the houses, Roses might naturally expect a good time. No one can have judged at the National Rose Show without being aware that the largest growers would find the Devon Roseries dangerous rivals, but I was hardly prepared for the extent to which Roses are cultivated. The nurseries cover about twenty acres, of which twelve acres are always fully occupied,

while eight are more or less resting with other crops, or taken up with standard seedling Briars or Manetti stocks.

With 3 feet of rich red loam—everything is "red" about here, rocks, roads, sands, soil, and cows into the bargain—but with such soil in a sheltered valley, trenched two spits deep, and forked at bottom, and then heavily manured, how can Roses avoid flourishing? The rows of last year's budding were magnificent in size and height, though, like everywhere else, this year afflicted with mildew. Mr. Chesterfield, the very intelligent head of the Rose department, informed me that it came on suddenly, about the middle of July, up to which the promise had been magnificent. The rows of Madame G. Luizet looked especially uncomfortable, more than kept in countenance by Her Majesty, whom I have also proved this year to be a martyr to mildew. It is not considered here a free bloomer. The Bride, especially under glass, is very highly thought of, but the new Roses in general do not excite much admiration. Clara Cochet is not much liked.

One result of this hot season has been an extra amount of well-ripened seed pods. Should the firm, as they hope, be successful in seedlings, we may see more than one new *Devoniensis* gold medallist at the National.—A. C.



A CORRESPONDENT writing from Hampton, Middlesex, states that on the morning of the 15th inst. 4° of frost were registered there, Vegetable Marrows and Scarlet Runners being cut in a remarkable manner; and he notices as a strange coincidence, tropical heat and nipping frost in the same week.

— VEGETABLE TRIALS AT CHISWICK.—At a meeting of the Fruit and Vegetable Committee of the Royal Horticultural Society, Chiswick, on the 12th inst.—present: Mr. Peter Barr in the chair, Messrs. Roberts, Saltmarsh, and the Secretary—the Committee examined the collections of Onions, Potatoes, and Tomatoes growing in the garden. Amongst Onions, Rousham Park Hero and Anglo White Spanish from Mr. Deverill, and Sandy Prize from Mr. Laxton, were selected as excellent stocks of the White Spanish Onion that should be tried again next year, and White Queen (Carter) was commended as a very true stock. Potatoes—fourteen sorts were selected and cooked; none of them was considered equal in quality to existing kinds. Of Tomatoes, of which eighty-seven samples were grown in pots, the following were considered worthy of three marks each—viz., Horsford's Prelude (Horsford and Pringle), medium-sized smooth red, a very free bearer; Livingston's Perfection (Farquhar, Veitch), large, smooth round, red, very free; President Cleveland (Farquhar), large, round, smooth, handsome; Ham Green Favourite (Crocker), very large, smooth, round, early, and prolific; No. 1 (Watkins & Simpson), large, round, smooth, very free; No. 3 (Watkins & Simpson), medium-sized, roundish, sometimes oblong, smooth red, producing large clusters, a remarkably free cropper.

— FROST IN SURREY.—A correspondent informs us that the first frost of the season occurred in the district of Kingston-on-Thames on the morning of Monday, the 13th inst., when the hedgerows and ditches were quite white with rime, and in some places 2° of frost were registered.

— ON Wednesday the 17th inst., a violent thunderstorm accompanied by strong and vivid lightning, visited Wimbledon and neighbourhood. The rain was preceded by a terrific hailstorm, which did much damage to vegetation. At Kingston there was a perfect deluge of rain, but towards Teddington, Twickenham, and Hounslow it was not so heavy. The rains will do an immense amount of good to the country at large.

— OUR readers will regret to hear of the death of MR. ARCHIBALD FOWLER, of Castle Kennedy, N.B., gardener to the Earl of Stair. This occurred suddenly on the night of the 14th inst., when Mr. Fowler appeared to be in his usual state of health. He was born in 1816, and was consequently seventy-one years of age, having been forty-seven years gardener at Castle Kennedy.

— BULBS FOR THE LONDON PARKS.—We are requested to announce that Her Majesty's Commissioners of Public Works have accepted the tender of Messrs. James Carter & Co. of High Holborn,

London, for the supply of bulbs for planting in Hyde Park, Regent's Park, Battersea Park, Victoria Park, Kensington Park, Kennington Park, Hampton Court Palace, and the Bethnal Green Museum.

— NEW DOUBLE POMEGRANATE.—“C. O.” writes:—“A valuable addition to this class is now in flower at Messrs. J. Veitch & Sons' Coombe Wood Nursery, named ‘*Punica granatum André Leroy*.’ The flowers are very distinct and striking, being of a bright orange scarlet, deeply edged with cream, very showy and effective. Plants flowering in small pots in the plunging ground give sufficient evidence that this variety is much more floriferous than the original type, which rarely blooms in a young state. Consequently it should make a very effective wall plant.”

— WE are informed that a sad accident has occurred to MR. THOMAS BOSTON, some years since the manager of Messrs. Carter and Co.'s nurseries at Forest Hill, but who has for a long time lived in the neighbourhood of Birmingham. He has been residing at Solihull, and was crossing the line of railway adjoining Messrs. Hewitt & Co.'s nurseries on Saturday last, when he was knocked down by a train he failed to see, and so severely injured that his recovery is doubtful. Only about two hours previously he met Mr. Hewitt and another old friend on the platform, and thoroughly enjoyed a few minutes' chat with them.

— HYBRID CANNAS.—“Cannas,” writes “C. O.,” “have hitherto been cultivated as much for their foliage as their flowers, but there is no reason why they should not take their place amongst flowering plants more than they do for conservatory decoration. There seems to be a future before them, judging by the varieties exhibited by Messrs. E. Morse & Sons of Epsom, at the Sutton and Cheam Show last week, of some new hybrids imported from the Continent. These show a great improvement in the size of the flower and the depth of colouring, which includes shades of deep crimson, scarlet, and orange, some spotted and marbled on a light orange ground. These should be looked after by cultivators.”

— WE have received a short report of the LINDFIELD SHOW which was held on the 17th inst. The principal features were the groups of plants exhibited by Mr. T. Venn, gardener to W. Sturdy, Esq., Paxhill, Lindfield, who was deservedly awarded the first prize; Mr. Hodges' gardener to P. C. Gibbons, Esq., second; Mr. A. J. Brown, gardener to W. Saville, Esq., Finches, Lindfield, third; Mr. Braysher, gardener to Mrs. Catt, was placed fourth. Some fine bunches of Grapes were exhibited by Mr. Hodges, also some very fine Cockscombs from Mr. A. J. Brown. The same exhibitors appear to have won most or all the prizes in the remaining classes.

— A LANCASHIRE correspondent writes:—“This season has been a trying one for EVERGREENS, but in spite of the long-continued drought they look remarkably well. This is especially noticeable with those that have had provided for them previous to planting a good deep root run. In positions where the soil was very shallow and deepened by carting fresh material they have done well and made generally luxuriant growth. Those growing on the natural soil deeply worked and liberally manured previous to planting are also conspicuous by their healthy appearance. Those on shallow soils badly prepared or existing in soil that is anything but fertile have in many gardens a wretched appearance.”

— “A NORTHERNER” says:—“Perhaps the best of all LILIES FOR PLANTING AMONGST SHRUBS is the old *L. candidum*, for without doubt during its season of flowering it is unrivalled amongst hardy plants. It would be impossible to imagine anything more lovely than good well established clumps with ten or a dozen flower stems, 5 feet high, carrying each about twenty of the purest of white flowers. Next to this for such positions *L. testaceum* with its creamy yellow flower stands out in a noble manner, plants this year having attained a height of nearly 6 feet. *L. tigrinum Fortunei* and *L. tigrinum californicum* are also good growers, and increase most rapidly. They are both very beautiful amongst shrubs, but the former attains a much greater height than the latter, and therefore, for many positions, is the most desirable. In good soil it readily attains a height of 7 feet. They are so near alike, that for this purpose one variety only is needed, and in that case *Fortunei* is preferable.

— “SEASONS like this,” he further observes, “have their advantages, and teach us valuable experience that cannot well be gained by the

weather of ordinary English summers. The hot dry weather has clearly tested DEEP *versus* SHALLOW CULTIVATION, and shown in a marked degree those evergreens best adapted for growing under large forest trees, or in close proximity to them. Rhododendrons, whether the common ponticum or hybrids, are not well adapted for this purpose; they do very well while the forest trees are of moderate size only, but when they become large, and the soil poor, Rhododendrons show by the manner in which they have suffered that they are useless for such positions. They certainly stand better where they are thoroughly shaded by the trees than where fully exposed to the sun. Many in such positions have suffered beyond recovery, while Aucubas, Evergreen Privet, and Hodgins' Holly have not displayed the least signs of distress. These are unquestionably three of the best shrubs that can be utilised for planting as undergrowth or in close proximity to forest trees.”

— THE GOLDEN ELDER.—The most ornamental shrub amongst deciduous trees, or even evergreens, in many gardens this year has been the Golden Elder with its large bright highly coloured foliage. For dry banks and exposed sunny positions it is charming, and should be planted in all gardens. It is useless to plant it in the shade, for its foliage then does not assume its brightest colouring. It is easily propagated, for strong shoots cut into lengths of a foot any time during the winter, and inserted into the ground, leaving only one or two eyes out, will take root and grow into large specimens in two or three years.

— “A. O.” informs us that Fuchsias *gracilis* and *Riecartoni* are flowering most profusely this year, better than they have done for some years past, but have not attained nearly the same height as usual. They are beautiful just now, and show how well they are adapted for large beds, or in isolated positions on the lawn or in shrubbery borders. They should, however, always be planted where they can enjoy plenty of light and air. Two years ago he planted a large number amongst a clump of dark Hollies in conjunction with *Anemone japonica alba*, and the Fuchsias form a good groundwork, and are very striking from any position from which they can be seen.

— GLOIRE DE NANCY CARNATION.—“E. M.” thinks it may not be generally known that for supplying white scented flowers at this time of the year this Carnation is most valuable. It possesses a Clove-like scent, blooms freely, and the flowers last a considerable time when cut, and a mass of them in a bowl or vase, with its own grass, forms a striking object. More than all this, it stands the excessive dry weather well blooming freely all the time without artificial aid, provided the plants were well established early in the autumn and carefully mulched through the winter. The best way to establish a stock of plants is to layer at once any stock plants, keeping the soil about them moist until roots are formed, and plants will be ready for planting in their permanent quarters by the middle of October, when they have a chance to make some fresh roots before severe weather sets in. The plant being of a dwarf robust habit, requires little support for the blossoms. This variety succeeds well in pots, producing a supply of flowers early in the season of Carnations.

— No plant at this time of year, and in such a dry season, makes a better show than does *HARPALIMUM RIGIDUM*. Drought does not seem to affect it nearly so much as many other border plants, particularly when growing in a deeply worked holding soil. Under good cultivation the plant grows from 4 to 5 feet high, blooming most profusely, its pale yellow flowers with a black centre being highly effective. It is easily increased by dividing the suckers which spring up around the old plant in the spring; indeed, the difficulty seems to be to keep it within bounds when once fairly established.

— “BRADWEN” writes:—“A very successful Show was held at Portmadoc on the 5th inst., and the exhibits in all classes were exceedingly meritorious. The large number of cottagers exhibiting this year compared with the earlier years of its existence proves the amount of good done by the Society in improving the habits and cultivating a better taste among the people. The chief prizetakers in fruits and plants are the Hon. C. H. Wynn, Rhug, Corwen (Mr. Bennett, gardener), J. Vaughan, Esq., Nannau, Dolgelly (Mr. Cooke, gardener), R. M. Greaves, Esq., Wern, Portmadoc (Mr. Davies, gardener), J. E. Greaves, Esq., Giceith (Mr. Morgan, gardener), T. S. Percival, Esq., Portmadoc (Mr. Severne, gardener), Lady Ewing, and F. W. Foster, Esq., Carnarvon (Mr. Dodding, gardener). Special prizes were given by

T. Cumming, Esq., Mr. J. James, High Street, and Messrs. W. Clibran and Son, Altrincham and Manchester. In addition to prizes given for horticultural subjects, a few good prizes were also given for honey, extracted and in supers, a practice which, if continued, will awaken an interest in the remunerative study of bees."

— SUTTON'S EARLIEST OF ALL TOMATO.—"W. K. W." writes:—"This valuable new variety is in my opinion more remarkable for its productiveness than for its unquestionable earliness. As a heavy cropper I have never grown one to equal it. Sown on the same date and treated in all respects exactly the same as Dedham Favourite it ripened fruit a week earlier; but what is to me of more importance is that each plant is bearing at the least three times the weight of fruit as are the plants of that variety. The fruit is large and of a very bright colour, somewhat irregular in shape, and corrugated. For amateur cultivation and for market growers it is, I believe, unsurpassed, if equalled, by any variety cultivated."

— THE same correspondent directs attention to the usefulness of TUBEROUS BEGONIAS FOR AMATEURS, observing—"At each of the flower shows I have this season had an opportunity of visiting (and they have been numerous), I have been struck with the fine examples of these plants shown by amateur growers; healthy well grown plants with good foliage and fine flowers have been the rule. Small groups of plants arranged for effect are now very popular at most shows, and no class of plants seems to surpass these (especially those with deep and bright colours) for brightening and giving effect to these small groups for amateur and small growers, and with whom Orchids are as a rule unattainable."

— "A YORKSHIRE GARDENER" refers to the POTATO CROP as follows:—"In spite of the long-continued drought we have experienced the Potato crop, in so far as the Ashleaf and other early kinds goes, is this season with us exceptionally fine both in quantity and in quality of produce. The later, or main crop varieties, are looking exceedingly well, and I believe there is little doubt the crop will be heavy and good, unless heavy rains set in before they are matured. Evidently the Potato does much best in a comparatively dry summer, and will bear a great amount of long-continued dry weather with impunity, provided that the subsoil is of a moisture-holding character; where it is of a gravelly character the Potatoes are this year small and more or less scabbed."

— REFERRING to the APPLE CROP, the same writer remarks:—"During the past week I have had opportunities for making observation amongst the best fruit-growing districts in the West Riding of Yorkshire, and have been astonished at the heavily laden trees which have come under my notice, especially those of the Codlin varieties. The fruit will be smaller than usual, as the trees are in most cases badly infested with red spider. There is also great complaint of the fruit being 'grub eaten;' but notwithstanding these drawbacks, I believe the crop will, upon the whole, be a fairly good one."

— THE annual Exhibition of the CHEADLE HORTICULTURAL SOCIETY was opened on the 19th inst. under most favourable circumstances, the general display being considered by those qualified to judge one of the best held in the provinces. The prizes, which ranged from £15 to 1s, were mostly well contested, the chief being that for fifteen stove and greenhouse plants. This was well won by Mr. R. Mackeller, gardener to J. Watts, Esq., Cheadle, with specimens denoting superior cultivation. The groups were a conspicuous feature, being circular in outline, and in sufficient numbers to fill the centre of a long tent. The majority were, however, too formally arranged, a notable exception being the one from Mr. Williams, gardener to S. Baerlien, Esq., Didsbury, to whom the first prize was most deservedly awarded. In cut flowers special mention should be made of the epergne shown by J. Heine, Esq., Fallowfield, whose exhibit was highly meritorious. Miscellaneous plants, fruit and vegetables, were shown in large numbers and excellent condition. The arrangements of the Show left nothing to be desired, thanks to the exertions of a good working Committee and the energy and enthusiasm of the popular Secretary, Mr. Stone.

#### THE FRUIT SUPPLY AND PACKING.

A CONTRIBUTOR to the *Daily News*, in preparing an account of the fruit of the season, and its condition as affected by packing, appears to

have availed himself of the resources of Covent Garden Market for information—an excellent "source of supply," and some of his remarks are interesting and suggestive, therefore we reproduce them as follows:—

It is possible now to arrive at an approximate estimate of the year's fruit, and on the whole it seems to have been fairly satisfactory all round, or nearly so, and there is good reason to expect that it will continue so to the end. There is, as usual, great diversity of testimony upon the subject amongst those who may be supposed to know the market well. The Cherry crop, for instance, the last of which is now coming in, is by some declared to have been a good average crop; by others it is pronounced to have been a quarter of a crop at the utmost. These are usually sold by the growers as they hang on the trees, and are picked by the buyers. It seems generally admitted that crops have not been heavy, but they have come to market in excellent condition. In the early stages of growth rain is necessary for Cherries, but when they have done their stoning they get along very well apparently in a dry, hot summer. It is better for them than showery weather, which no doubt tends to plim them out, but is also very apt to crack them and to send them to market in a wet and unsatisfactory condition.

This matter of condition, by the way, is a more important one than many growers appear to understand. Those who go thoroughly into the trade of course soon get this impressed upon them; but there are many amateurs and small growers who send up fruit to agents at Covent Garden, and who do not realise how much depends on condition in these days of keen competition. A gentleman's gardener has a crop of Peaches, for instance, which he wishes to dispose of in the market. They are first-rate fruit, and the grower thinks they ought to fetch the top price. But he gathers them for market just as he would for his master's table—that is, just when they are in the perfection of ripeness. He makes no allowance for the time that must elapse before they can reach the consumer, nor does he consider the great liability to damage incurred by fully ripe fruit in transit. The Peaches come to market carelessly packed and a little over-ripe, and perhaps a few of them bruised, and then, when they realise something considerably below the top price, there is great dissatisfaction. This is a common difficulty with all sorts of amateurs who send fruit to market. They fail to apprehend that condition, as well as quality, is one of the items that go to determine price on the market.

Generally speaking, this year fruit has come into Covent Garden in exceptionally good condition, and, judging by the tone of opinion in Covent Garden, dealers and growers have not much fault to find with the season. The chief drawback has been the rapidity with which fruit has ripened, and the consequent glut of the market with too many kinds at once. The trade, of course, likes to get crops in a regular succession, one fruit being cleared off before another comes on. This year, however, all the "soft" fruit has come in in a rush, and prices have consequently been lower than they otherwise would have been. But nobody seems to be grumbling much, and it is reasonable to assume therefore that the season on the whole has been fairly good. The Strawberry crop is allowed to have been a good one while it lasted, and for small growers who could water their beds it must have been a satisfactory year. With abundance of sunshine Strawberries ought always to do well in the small garden, because it is always easy to give them the moisture they require. By large growers this could only be done by some system of irrigation which would not be required most years, and which it would not pay to adopt for such exceptional seasons as that of the present year. The failure of rain this summer brought the Strawberry cropping to a sudden collapse when the first fresh vigour of the plants came to an end. The fruit was very abundant for a time, but it dropped off a fortnight or three weeks earlier than it would have done with an average rainfall. It is described in the market as half a crop this year, and of Raspberries about the same is said. Of course it pays better to have half a crop at a good price than a great glut which will fetch next to nothing at all. One grower is mentioned as having sold 40 tons of Strawberries which he anticipated being able to supply from his own beds, but he did not find 20 tons. Black Currants are spoken of as about a third of a crop, but in many parts they have been a total failure. Red Currants have been generally abundant, Gooseberries only about half a crop on the whole, though in some localities the fruit has been very plentiful.

Apples seem to be a very variable crop this year. In many parts of the suburbs of London Apple trees appear to be in danger of extinction from a pest of caterpillars which attack the leaves as soon as they are well developed and devour every scrap of them. When they have fairly stripped the tree of every atom of foliage they retire into snug corners, where they assume the cocoon state, and after awhile emerge in the form of a little silvery white moth, to lay myriads of eggs for next spring. Thousands of Apple trees, especially round London, have been subject to this pest for several seasons past. The trees throw out a second crop of leaves, but of course they are weakened, and the following spring they fail to bloom. An Apple tree in fine full bloom is becoming a rarity in some quarters of suburban London. It may be useful to amateurs to point out that an effectual remedy is found in a sprinkling of paraffin oil. If a couple of wineglasses of oil be put in a pail of water and the tree be well syringed just where the caterpillars are beginning their havoc it will destroy most of them, and one or two repetitions at intervals of two or three days will quite clear off the pest. The oil and water must be kept mixed up by brisk syringing into the pail. We are informed by Mr. Foord of Covent Garden that this mixing may be accomplished more effectually by well combining the paraffin with a quantity of



softsoap, which may then be easily stirred into the water and syringed over the tree without any danger of mischief, which is sure to result from the touch of pure paraffin on any kind of foliage.

Early Apples are now in the market. They are English grown, and for the most part come from Chiswick, Isleworth, Fulham, Windsor, and other grounds not far out of town. Kent sends a great many, but the crops are very irregular. Round Maidstone Apples are reported to be scarce; a little further down trees are fairly well laden. Of foreign Apples it is, of course, too early to speak, but it seems to be expected that the English orchards will yield a good half crop. English Pears do not seem to count for much in the market; the bulk of our supply comes from France. Last year was a wonderful Plum season. This year Plums are very irregular. In the neighbourhood of London and the home counties the trees are reported to be well laden, but so far as can be ascertained the crop throughout the country is not likely to be heavy, indeed one very good authority puts it down at not more than a quarter of a crop.

Among the most noticeable features of this season's fruit market is the advance which English Tomatoes are making. Till recently Lisbon has very largely supplied us, but our own growers are rapidly driving the Portuguese Tomatoes out of the market. We get some from the Channel Islands, but Worthing seems to be now monopolising the trade. So long as Tomatoes were chiefly used for sauce-making they were grown to a very large extent out of doors; but out-of-door fruit has no chance in the market now, and at Worthing there is an enormous expanse of glass devoted to the growth of this recent candidate for popular favour. It is very noticeable that from being a delicacy in favour with the few, the Tomato has become to a very large extent popularised. Costermongers are beginning to get them on their barrows, and they take them in increasing quantities. One peripatetic dealer recently mentioned by a salesman in Covent Garden will buy thirty or forty baskets containing 14 lbs., and he will do this just as often as he can buy at his price, retailing them among the poorest class of customers.

#### CHRYSANTHEMUM GROWERS ENJOYING THEMSELVES.

ON Wednesday the 17th inst. about fifty members and friends of the National Chrysanthemum Society paid a visit to Messrs. Cannell and Sons' establishments at Swanley and Eynsford. Having arrived at Swanley we proceeded to view the beds of annuals, which were in quite a blaze of colour considering the dry season. The Dahlias grown for exhibition are a grand feature, particularly the Caetus class, which are just beginning to show their attractively shaped flowers. Plants of the other class for show promise well for a good bloom, being very strong and healthy. About half an acre of Zonal Pelargoniums bedded out were in splendid condition, all the best varieties in commerce being represented. They quite took the visitors by surprise. We then passed on to the Chrysanthemums, which looked well and promising for a good bloom. Many of the early varieties are already housed, but they seemed dull beside the more highly coloured flowers to be seen. The houses of single and double Pelargoniums were very gay, the flowers being large and of good form and substance, and, the colours of the different varieties being effectively arranged, the effect was dazzling. We next came to the single Begonias, the grandest feature here. They fairly astonished us, many of the blooms being quite 6 inches in diameter, and the colours most vivid amongst the scarlet and crimson varieties. In one house there was a large batch of whites of splendid form and purity of colour, which set all wondering what the art of flower raising was coming to. The four next houses—these houses are 100 feet long—were full of double Begonias in various stages of growth, from small seedlings to others in full bloom, many of the blooms having the appearance of moderate sized Hollyhocks, and some Pæony-shaped, the colours being very delicate. In one house the arrangement was very harmonious, the plants being Fuchsias, Cannas, Lilies, &c. The marking of the various kinds of Cannas attracted our attention, and at some not very distant date Cannas must take a prominent place in our flower decorations.

Mr. Cannell provided a luncheon for the party before proceeding to visit Eynsford Farm, which is only about six minutes run by train from Swanley. Eynsford is the new site for Messrs. Cannell's future nurseries, they having completely outgrown their seventeen acres at Swanley. We had a good view of Sir W. Hart Dyke's Castle and splendid wooded park, and beneath us flowed the river Darent. The farm is about 300 acres in extent, the views from the hillsides over the valley most charming, and to our surprise arrangements were made to photograph the party, Mr. Cannell being in the centre of the party on his pony "Tom." He then conducted us over the estate, through the woods, over the hills down into the valley below to the old farm house, where, in a large barn, we found an excellent repast laid out for the visitors. Our President, Mr. Sanderson, thanked Mr. Cannell for his hospitality and kindness, and Mr. Cannell in responding said he hoped to make one of the most complete horticultural establishments in the world. We found about three acres of a large meadow trenched up and planted with hardy fruit trees, looking remarkably well considering the dry season, and Mr. Cannell stated it was his intention of breaking up and planting six acres more in the autumn.

We next examined a monster water tank, built on the hill. This is the finest tank perhaps ever constructed by a private gentleman. Sir W. Hart Dyke constructed it at a cost of £1000, to supply the farmers on his estate. The supply is from the river Darent, near the Castle, there

being nearly two miles of 4-inch pipes running across Mr. Cannell's grounds in three different directions, so by tapping the main he can run a barrel pipe to any spot on the 300 acres. The site for the glass structures has been chosen, and preparations are now being made for their erection within sight of and a short distance from the station. After our inspection we took train for home, one and all having spent a very pleasant and enjoyable day.—ONE OF THE PARTY.

#### WENTWORTH CASTLE.

A FORTNIGHT ago a report of the meeting of the Yorkshire Association of Horticultural Societies at Barnsley appeared in our columns, and it was stated the company paid a visit to Wentworth Castle, the seat of T. F. V. C. Wentworth, Esq., who accorded them the privilege of inspecting the mansion and grounds. The following account of the visit has been obligingly furnished by an excellent gardener, who shared in the enjoyments of the day, and the illustration of the flower garden is engraved from a photograph.

Wentworth Castle, distant about three miles from Barnsley, was reached through a delightfully undulating and well wooded country. Charming views were obtained from various points, and the drive was thoroughly enjoyed. Arrived at the Castle the party alighted at one of the entrances to the park, and in a few minutes reached the mansion, which occupies a commanding position, and seen from a distance forms an important feature in the landscape.

The horticulturists were met by the veteran chief of the gardens, Mr. Batley, and cordially welcomed to Wentworth, and the extreme care and incessant attention shown to the visitors by Mr. Batley and his son, Mr. George Batley, will long be remembered with pleasure.

Acting on Mr. Batley's advice the party first visited the castle, where they were conducted through the principal rooms, including the magnificent picture gallery, which is of great size, being 180 feet long, 26 feet wide, and 30 feet high. Here were numerous examples by the old masters, such as Vandyke, Rubens, Titian, Guido, Carlo-Maratti, Rembrandt, Murillo, Van der Helst, and others. Time would not permit of more than a cursory glance at these, and after leaving the Castle the visitors were conducted through the extensive and well kept pleasure grounds.

Near the mansion is situated a spacious conservatory, built of iron and glass on the ridge-and-furrow principle. Here are some large plants of Orange and Lime trees, the latter bearing exceptionally fine fruit, also noble examples of Palms, such as *Chamaerops*, *Arca sapida*, *Latania borbonica*, &c., under the shade of which winding walks were formed, the groundwork between being covered with masses of Ferns, Mosses, Begonias, &c., whilst flowering plants were tastefully arranged in the front or sunny part of the structure, amongst which several pots of *Lilium Harrisii* with its pure white trumpet shaped flowers stood out prominently. The roof throughout is gracefully festooned with healthy and well-flowered specimens of *Passifloras*, *Tacsonias*, *Cobceascandens*, and other suitable plants. When lit up by means of the electric light, with which this fine house as well as the whole of the establishment is furnished, the effect must be charming and fairy-like in its nature.

After leaving the conservatory we passed through shady avenues, noticing fine specimens of Turkey Oak, Spanish Chestnut, Cedars, Hollies, and Yews, and arrived at the flower garden, which though not extensive was exceedingly effective. *Calceolarias* were remarkably fine, and a seedling *Lobelia* of a very dark colour was greatly admired.

The old Castle was next visited, and the views from here were very fine. In the distance were pointed out Wortley Hall and the woods surrounding Wentworth Woodhouse, the seat of Earl Fitzwilliam.

Returning from the pleasure grounds the fruit and kitchen gardens were entered, in which the various crops showed unmistakable signs of skilled and careful management.

The houses, twenty in number, were devoted to the growth of Grapes, Peaches, Cucumbers, Melons, Tomatoes, table and decorative plants and other things necessary to the well being of a first class establishment.

One house contained some splendid examples of Black Hamburgh Grapes, which for size of berry and perfect finish would be difficult to surpass. An adjoining house contained a fine crop also promising well. The Muscat house planted last spring with Vines from newly struck eyes is now furnished with grand canes, short-jointed, and reaching to the top of the house.

A span-roof house is principally filled with Black Alicante (an especial favourite with Mr. Batley as a late Grape), which he usually keeps in good condition until May. The Vines are carrying a very even and heavy crop of good size bunches, which promise to finish well.

The vegetable crops looked remarkably well, notwithstanding the long continued drought, and before leaving the gardens the party spent some considerable time in inspecting the old and interesting sundial which was planted in the year 1732 by Benjamin White, who was then gardener, and whose initials are still recorded. The gnomon is formed by a Yew tree, kept in proper shape by clipping. The hours, half hours, and quarters are marked on the dial plate with dwarf-growing Box.

Before leaving this, the home of the Wentworths, one of Yorkshire's most highly respected and popular families, we may mention that Mr. Batley's father came to Wentworth Castle as a lad, and eventually became gardener, to be succeeded by his son, who now so worthily fills the position, and one could not but wish that long may the Wentworths reign at Wentworth; and as long may they be served by the Batleys, and thus prove to the world in these somewhat "high

pressure" days that the patrician can still make a "friend" of his faithful servant, and the servant can prove that he is worthy of the trust that reposed in him.

[Mr. Batley is not only an able gardener and devoted servant, but an accomplished man. During a short visit to Wentworth in good company, but on a miserable day some years ago, we were not more impressed with the splendid conservatory and superior Grapes than with oil paintings of Mr. Batley, which were wonderful in their fidelity of description and admirable in execution. If we remember rightly Mr. Batley's son is also talented, and it is very rare indeed to find works of art by gardeners approaching in merit to those at Wentworth; nor is Mr. Batley a "kid-gloved dandy," and we doubt not he can wield the gardener's spade as well as he can use the artist's brush. Yorkshire ought to be proud of him.]

## HORTICULTURAL SHOWS.

### DUNMORE.

This is an annual event looked forward to with considerable interest by a large concourse of patrons from not only the immediate locality but all

esque a marine prospect as ever gladdened the eye of the scenic painter—"an emerald set in the wing of the sea." The town, with all its natural beauties and bathing facilities, is underneath, with Creden Head to the left, and across the Channel the magnificent residence of Loftus Hall, the handsomely situated seat of the Marquis of Ely on a promontory terminated by Hook Head. If anything is needed to complete the picture, the observer need but slowly turn to the right and around from the many fine residences to that of Villa Marina, the palatial house of Mrs. Malcomson, where a most hospitable welcome on such occasions is extended to all the surrounding gentry and visitors by herself and her son, Joseph Malcomson, Esq., late High Sheriff of the county. The bay and harbour, too, are filled with yachts and fishing smacks.

Returning to the Exhibition tents we come to the competing exhibits in the several sections, and purpose noting the most meritorious, with a few suggestions for improvements of others. Mr. J. A. Colthorpe, for the President, the Hon. Dudley Fortescue, was more than ordinarily successful in the several sections, winning first prize for well-grown specimens of exotic Ferns, including *Adiantum farleyense*, *Gymnogramma*, and *Lomarias*; first prize for greenhouse plants with ornamental foliage, such as *Croton nobilis variegatus*, and highly coloured *Dracenas*. The *Croton* gained him first prize in the Show. He was also successful with stove and greenhouse plants in the "miscellaneous collection," and first

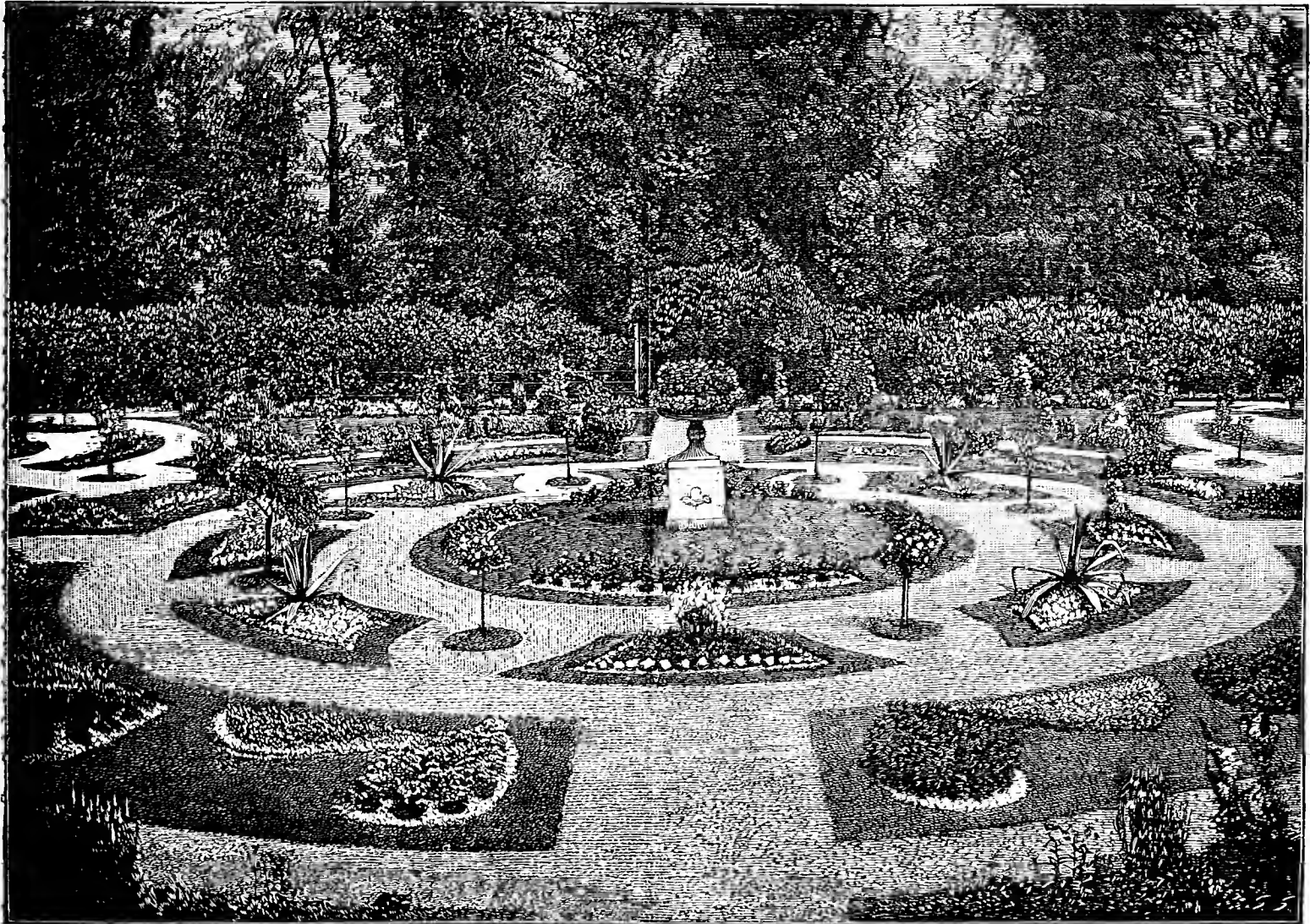

Fig. 20.—FLOWER GARDEN AT WENTWORTH CASTLE.

the surrounding counties; and from the circumstance of the Show this year being held on a holiday, two steamers (the *Ida* and *Tintern*) were necessary to take the number of excursionists from Waterford by that route alone. New Ross, Tramore, and other towns on the coast furnished contingents by water, while numbers went from Limerick, Clonmel, and intermediate towns, as well as from Kilkenny and other stations on the Central Ireland line, taking advantage of the excursions liberally given by the several companies. The President of the Dunmore Horticultural Society is the Hon. Dudley Fortescue, D.L., Summerville, who is assisted by a zealous Committee, wisely selected, half of gentlemen proprietors and half of gardeners, consisting of Sir Robert Paul, Bart., Henry Morris, William King, and Patrick Power, Esqrs., Rev. J. Burke, C.C., Dr. Jackman, and Messrs. Harney, Calthorpe, Dunphy, O'Brien, N. Power, J. Noonan. The Treasurer is the worthy Rector of the parish, Rev. W. G. Gilmour; while Joseph Malcomson, Esq., Villa Marina and Ballinakill House, is ably assisted by Mr. Harney, Dunmore East, as Hon. Secretaries. Taking a general look through the whole Show the first thing that would strike the most casual observer was the general excellence in the several sections such an extraordinarily warm and dry season. This applied more particularly to vegetables, cut flowers, and fruit grown out of doors. While the staging is being completed we have an opportunity of looking around from the park, where the marquees are situated, on as smiling and pictur-

for a healthy specimen Tree Fern; while his *Colcus* and *Caladiums*, after close competition, still maintained the premier place for size. Joseph Malcomson, Esq. (Mr. Noonan, gardener), was a good competitor in the foregoing plant classes, and coming first for Tuberos *Begonias* and *Fuchsias*, and second for stove plants and *Coleuses*, very well coloured. Lady Carew (Mr. O'Brien), Woodstown, was first for *Lilium lancifolium*, and second for good Tuberos *Begonias*. The premier place for single Zonals and new Ivy-leaf *Pelargoniums*, after close competition, went to W. King, Esq., Mountpleasant (Mr. N. Power). The Judges in the Zonal classes strongly recommended the disuse of sticks standing porcupine like all around the specimen plants. Mr. James Noonan, gardener to Joseph Malcomson, Esq., Ballinakill, Waterford, was the only exhibitor of field roots, and certainly the collection did him credit.

The next section was cut flowers, and this seemed the only one somewhat behind former years, but this was readily accounted for by the extraordinarily dry season. Next came the fruit section, always worth noting at Dunmore; but, as in former years, Mr. Calthorpe proved a formidable competitor, carrying away first prize for Black Hamburg, Black Alicante magnificently coloured and grown, and White Muscat of Alexandria. Mrs. Malcomson, Ballinakill House (Mr. Noonan), had as large and as fine Peaches as the Judges ever saw, but they were unfortunately badly bruised in transit, and Mr. King came thus first. The



Melons, both scarlet and green-fleshed, were highly creditable, Mr. Calthorpe having a specimen of Carter's Blenheim Orange that would have gained a prize at any Show, while Mr. J. Malcomson's green-fleshed had similar honours.

Vegetables here are always a strong feature, and there were in some classes as many as six and seven competitors. We would, with some deference to the Committee, suggest that they make it an imperative rule in future that similar sorts of vegetables be staged together. No one will suffer thereby, and visitors as well as judges can see at a glance Peas, Beans, Beets, Carrots, Cauliflowers, or otherwise, with the exception of collections. Gardeners could not suffer, as every exhibit when staged becomes the property of the Committee, and are subsequently sold by public auction to recruit their funds. Probably the Onions of J. Malcomson, Esq., and Mr. Dobbyn (gardener, George Ralph), were comparatively unrivalled any season.

The Marchioness of Waterford's collection (not for competition) was also a special feature of the Show, and occupied the whole centre of one of the principal marquees, reflecting great credit on the noble marquis's head gardener, Mr. Tucker; and as the exhibits were presented for the benefit of the Show fund indicated the generosity of her ladyship, the marchioness. No hurried reference could sufficiently realise the superior merits of the cut blooms. The fine collection of fruit included such as Smooth Cayenne Pine Apples, black and white Grapes, Currants in variety, Cucumbers, Melons, &c. Before parting from the special exhibits and special prizes this may be the proper place to note that Messrs. Sutton and Sons, Reading, offered three handsome prizes for the best collection of vegetables grown from their specialities in seeds, the first prize being won by Mr. Noonan, gardener to Mrs. Malcomson, Ballinakil House. He had finely grown specimens of Sutton's new seedling Potatoes, Intermediate Turnip, Reading Carrot, &c. Messrs. W. Power & Son, seedsmen, King's Street, Waterford, and nurserymen, also offered three prizes for the best collection of garden vegetables, Mr. Noonan winning premier prize as before. Messrs. Saunders & Sons, Friars' Walk Nursery, Cork, staged a beautiful collection of cut flowers; as also did Messrs. Power & Sons, Waterford and Newtown Nurseries, including a special exhibit of single and double Begonias.

For this report we are indebted to one of the Judges, Mr. W. J. Murphy, Clonmel.

#### TROWBRIDGE.—AUGUST 17TH.

THERE are few older societies than this, no less than thirty-eight exhibitions having been held, and on the whole it may fairly be considered the most generally popular in the West of England. No large prizes are offered with a view to attract the most noted plant growers, but the extensive and generally good all-round display of plants, cut flowers, fruit, and vegetables amply compensates for any shortcomings in this respect. Mr. James Huntley has been for many years Honorary Secretary, and with him are associated a numerous and painstaking Committee.

The best nine stove and greenhouse flowering plants were staged by Mr. G. Tucker, gardener to Major Clarke, Trowbridge, who had medium-sized well-flowered specimens of *Statisia profusa*, *Ixora coccinea superba*, *Allamanda Hendersoni*, *Ixora Morsei*, *Stephanotis floribunda*, *Oncidium flexuosum*, *Rondeletia speciosa major*, *Allamanda nobilis*, and *Bougainvillea glabra*. Mr. J. Matthews, gardener to H. Brown, Esq., Trowbridge, was second, his best plants being a freely flowered *Erica Marnockiana*, *Erica McNabiana*, *Clerodendron Balfourianum*, and *Allamanda nobilis*. Mr. W. J. Mould, Pewsey, was third. With six plants Mr. H. Pocock, gardener to J. P. Haden, Esq., Trowbridge, was a good first, having beautifully flowered *Dipladenias Brearleyana* and *amabilis*, *Oncidium flexuosum*, and other well-grown plants. Mr. G. Tucker was second, his collection including the seldom seen *Eranthemum Andersoni* in good condition. Mr. J. Matthews was third. The last-named was first for three plants, showing a well flowered *Cattleya Harrisoni*, *Erica Eweriana*, and *Allamanda nobilis*, fresh and good. Mr. Pocock was second, and Mr. G. Pym, gardener to Mrs. Gouldsmith, third. The first prize for nine fine-foliaged plants was awarded to Mr. J. Emery, gardener to Colonel Pepper, Salisbury, his most noteworthy specimens being *Croton Prince of Wales*, *Dracaena Baptisti*, and *Croton Disraeli*. Mr. W. C. Drummond had a more valuable collection, but only received the second prize, the third going to Mr. J. F. Mould.

Ferns are always plentiful and good at the Trowbridge Shows, and they are most effectively grouped at intervals through the largest plant tent. Mr. G. Tucker, after a most careful examination of the plants by the Judges, was placed first with fifteen varieties, among these being good specimens of *Asplenium nidus avis*, *Cheilanthes pulchella*, *Gymnogramma sulphurea*, *Adiantum rubellum*, *A. cuneatum*, *Gymnogramma cristata*, and *Dicksonias*. The second prize was awarded to Mr. J. Coke, gardener to A. P. Stancombe, Esq., who had beautiful specimens of *Dicksouia squarrosa*, *Gleichenia spelunca*, *Trichomanes radicans*, and *Cibotium Schiedei*, but a few of the other plants were small. Mr. H. Pocock was a creditable third. Mr. J. Matthews was well first for *Colenses*, Mr. H. Pocock second, and Mr. G. Pym third; and for *Caladiums* Mr. Pocock was first and Mr. J. Matthews second.

Fuchsias, though scarcely so good as usual, were yet considerably ahead of what are seen in most other districts. All are grown as pyramids, are beautifully flowered, and the majority from 8 feet to 10 feet in height. Mr. G. Tucker was well first for six plants, these consisting of *Charming*, *Hon. Mrs. Hayes*, *Lye's Favourite*, *Thomas King*, *Marginata*, and *H. Lye*. Mr. H. Pocock was second and Mr. J. Matthews third. All had similar positions for four plants, *Doel's Favourite* and *Charming* being the best shown plants. The best four *Heaths* were shown by Mr. Matthews, Mr. J. F. Mould being second, and Mr. W. C. Drummond third. *Gloxinias* were very fine, Mr. C. Richmond, gardener to G. L. Palmer, Esq., Trowbridge, being well first, Mr. G. Tucker second, and Mr. A. A. Walters, Bath, third. Both double and single *Tuberons Begonias* were of great merit. Mr. Richmond had the best doubles, among them being a good plant of very fine crimson *Prince of Wales*. Mr. M. Cole, gardener to S. Tredwell, Esq., Bath, was second, and Mr. G. Tucker third. Mr. Richmond was also easily first for singles, and Mr. A. A. Walters second. Balsams were remarkably good. Mr. J. Weston, gardener to the Rev. C. C. Layard, Bath,

was first, and Mr. W. Mattick, gardener to J. G. Foley, Esq., second. *Cockscombs* were also extra good, and with these Mr. Mattick was first and Mr. J. Weston second, these exhibitors being equally as successful with *Verbenas* and *Petunias* in pots. *Zonal Pelargoniums* were very good, such sorts as *Eva*, *Lizzie Brooks*, *Rev. F. Atkinson*, and *J. Gibson* being especially well flowered. Mr. G. Tucker was first, and Mr. H. Pocock a very close second.

Cut flowers were very numerous, and in many instances remarkably good. For twenty-four varieties of choice flowers, Mr. W. Iggulden, gardener to the Earl of Cork, Frome, was well first, the second prize going to Mr. S. Bishop, gardener to W. E. Heard, Esq., Newport, Monmouth. *Roses* were fresh and of good substance, but the decisions were not altogether satisfactory. Dr. S. B. Budd was first for twenty-four varieties, having good even blooms, among which *Xavier Olibo*, *Marie Van Houtte*, *Perle des Jardins*, *Madame Lambard*, *Madame Berard*, *Marie Baumann*, *Duke of Wellington*, *Horace Vernet*, and *A. K. Williams* were the most noteworthy. Messrs. G. Cooling & Sons, Bath, followed closely. *Annie Wood*, Countess of Rosebery, Dr. Andry, *La Rosiere*, *St George*, and *Maurice Bernardin* being extra good. Messrs. Keynes, Williams & Co., Salisbury, were third, their best being *Thomas Mills*, *Rosieriste Jacobs*, *Sunset*, *Charles Darwin*, and *C. Lefebvre*. An extra prize was awarded to Mr. J. Mattock, Oxford. With twelve triplets Mr. Mattock was placed first, the most noteworthy in his stands being *Maréchal Niel*, *C. Lefebvre*, *Marie Van Houtte*, *Prince Arthur*, *Belle Lyonnaise*, and *Marie Baumann*. Messrs. Keynes, Williams & Co. took the second prize, though they apparently had a better lot than Mr. Mattock. Messrs. Cooling & Son were third, and an extra was awarded to Dr. Budd.

The best twenty-four Dahlias were staged by Messrs. Keynes, Williams and Co., and among these were fine blooms of *Colonist*, Mr. Spofforth, Miss Cannell, W. Rawlings, *Flag of Truce*, R. Dean, *Crimson King*, *Goldfinder*, J. T. Saltmarsh, Mrs. Gladstone, and *Henry Walton*. Mr. G. Humphries, Chippenham, was a good second, among his being fine blooms of *John Wyatt*, G. Harris, J. Ashby, J. W. Lord, and S. Hibberd. Messrs. Keynes & Williams were first for twelve Dahlias (fancies), J. O'Brien, *Gaiety*, *Peacock*, *Professor Fawcett*, *Chorister*, and *Rev. J. Camm* being most noteworthy in their stand. Mr. G. Humphries had a good even lot, and was second. Messrs. Keynes & Williams were again first for single Dahlias, and also for twelve bunches of *Pompons*, some of the best of the latter being *Lady Blanche*, *Isabel*, *Fanny Weinar*, *Wilhelm Nitsche*, *Gazelle*, and *Favourite*, *Darkness* and *Lælia*. Mr. Humphries was a good second. The best twelve Dahlias in the amateurs' classes were shown by Mr. T. Hobbs, Lower Easton, Bristol, the second prize going to Mr. S. Cooper, Chippenham. A wonderfully fine lot of *Asters* were shown. Mr. G. Garraway, Bath, was first for twenty-four French *Asters*; Messrs. J. Cooling and Sons second; and an extra was awarded to Mr. T. Salter, Bath. In a similar class for German varieties Mr. A. A. Walters, Bath, was first, and Mr. W. J. Jones second. The successful exhibitors in the amateurs' classes were Messrs. S. Cooper, W. J. Jones, C. J. Walters, *Calne*, and H. Catley, Bath. Mr. G. S. Walters was first for *Gladioli*, Mr. A. A. Walters second; and with *Hollyhocks* the prizewinners were Messrs. W. Smith and F. Hooper, Bath. *Cut Zonal Pelargoniums* were well shown by Messrs. J. Mattock and G. Cooling & Sons. Mr. E. J. Wilcox, gardener to Mrs. Sinkins, Frome, was easily first for a collection of annuals in bunches, and Mr. A. A. Walters second. Several good *Carnations* were staged, but the names of the prizewinners did not transpire, owing to the confusion attending the late discovery that Mr. F. Hooper and Mr. Catley, both of Bath, had a considerable number of made-up blooms in their stands. It was only by taking the blooms out of the stands that it could be seen how neatly two blooms had been joined together so as to deceive the Judges. A beautiful lot of vases and hand bouquets were shown, the competition in this respect being the best seen in this district. Miss M. A. Durbin had two first for vases, and was also first for a memorial wreath. Other prizewinners were Messrs. Hookings, Harraway and Scott, E. T. Hill, and J. Attwell. Mr. Hookings was first for a hand bouquet; Mr. Iggulden second, and Mr. C. E. Colston third. Messrs. Cooling & Son had several fine stands of *Roses* not for competition, a grand box of *Maréchal Niel* being especially noteworthy.

The fruit classes on the whole were fairly well filled, the competition being most keen with *Grapes*. Mr. J. Iggulden was well first for a collection of ten dishes of fruit, among these being well finished *Black Hamburg* and *Muscat of Alexandria Grapes*, *Hero of Lockinge Melon*, *Grosse Mignonne* and *Crimson Galande Peaches*, and *Moorpark Apricots*. Mr. H. Prosser, gardener to W. H. Laverton, Esq., Westbury, was a creditable second, his dishes of hardy fruit being very good. Mr. Iggulden was first for six dishes of fruit, and also for any black *Grapes*, staging in this instance medium-sized well-finished bunches of *Black Hamburgs*. Mr. E. T. Hill, Westbury-on-Trym, was second, and Mr. J. Gibson, gardener to the Earl Cowley, Chippenham, third, both having very creditable exhibits. With black *Muscats*, Mr. B. Hopkins, gardener to John Baily, Esq., Frome, was well first for large and very well-finished bunches of *Madresfield Court*, the second prize going to Mr. E. Trotman, gardener to J. Colmer, Esq., Bristol, and the third to Mr. H. Clack, gardener to C. E. Coulston, Esq., Devizes, these also having fine bunches of *Madresfield Court*. With *Muscat of Alexandria* Mr. W. Iggulden took the lead, having well-finished bunches, the second prize going to Mr. G. Shelton, gardener to W. R. Waite, Esq., Clifton, and the third to Mr. J. Loosemore, gardener to W. Cooper, Esq., Bristol. In the any other white class, Mr. J. Attwell, gardener to J. B. Brann, Esq., was first for very good *Buckland Sweetwater*, Mr. E. Trotman being second with the same variety, and Mr. A. Miller, gardener to W. H. Long, Esq., Trowbridge, third with *Foster's Seedling*. The last named was first for a fine fruit of *Charlotte Rothschild Pine Apple*. A considerable number of *Melons* were shown, but few among them were fit to eat. In the class for a green-flesh variety Mr. Prosser was first for a seedling, Mr. Iggulden second with *Sutton's Imperial*, and Mr. J. Weston received an extra third. Mr. J. E. Morris, gardener to S. J. Bythsea, Esq., was first for a scarlet-flesh variety, winning with a good fruit of *Hero of Wilts*. Mr. W. M. Cole, Bath, was second. *Peaches* and *Nectarines* were judged by flavour, and as a consequence the finest fruit did not win. Mr. C. J. Jones, Bradford-on-Avon, was first for *Peaches*, having a good dish of *Royal George*, Mr. W. Clack being second, and



Mr. Iggulden third. Mr. E. Trotman was first for Nectarines, Mr. C. J. Jones second, and Mr. B. Hopkins third, all having very good dishes of Elrge. Mr. Iggulden was first for Apricots, staging a fine dish of Hems-kerk, and Mr. Mattock was second. Messrs. E. Fisher, G. Tucker, Chichester, A. T. Hall, E. Hall, E. F. Pocock, R. Spackman, G. Smith, and G. Pymm were successful in the classes for Pears, Plums, Cherries, Apples, and Filberts.

The best collection of vegetables was staged by Mr. G. Garraway, among these being extra fine dishes of Telegraph Cucumber, Sandringham White Celery, Conqueror Tomatoes, Jubilee Runner Beans, Vicar of Laleham Potatoes, New Intermediate Carrots, Queen of the West Marrows, and Rocca Onions. Mr. T. Evry, Bathaston, was second. The best brace of Cucumbers was staged by Mr. Wilcox, and Mr. E. Fisher was second, both having Telegraph in good condition. The single dishes of Potatoes, Carrots, Turnips, and other vegetables were numerous and good.

#### SHREWSBURY SHOW.

The annual summer Show of the Shropshire Horticultural Society was held in the Quarry Grounds, Shrewsbury, on Wednesday and Thursday of last week. Of late years this Show has become universally known for its great excellence and astonishing success, and the grand Exhibition now under notice will certainly add further lustre to the high reputation of the Society. The benevolence of the officials towards charities and other worthy objects in the Shrewsbury district has become a household word wherever horticultural shows are spoken of, and their good name and commendable deeds are annually being augmented. In the balance-sheet for 1886 there will be found such items as these—"Treat to workhouse children," and "building the Lodge at the quarry entrance £486 6s. 5d.," and these are by no means the only donations to deserving institutions, as their generosity began long before 1886; and this makes it all the more gratifying for us to record another great horticultural and financial success for the Society this year, as in point of merit the Show of last week was second to none, and the receipts developed to extraordinary proportions. As a rule about £300 worth of tickets have been sold previous to the Show day, but this year the sale exceeded £500, and on the second day of the Show, when 1s. was charged for admittance, over £1100 was collected in hard cash at the entrance gate. The Society may be said to be rolling in money, but it also rolls in zeal; and it would almost be superfluous to remark on the hard and well accomplished work of the Committee, as the results of succeeding years speak volumes for its admirable management. It may, however, be observed that the Committee, which includes many of the leading inhabitants of Shrewsbury, are not above enrolling many good practical gardeners on their list, and if ever a company of two Honorary Secretaries deserved the genuine and unbounded thanks and praise of their neighbours, the horticultural press, and all lovers of first-class exhibitions, it is surely Messrs. Adnitt & Naunton. The whole of the produce was exhibited in tents, the larger being of immense size.

**PLANTS.**—The prizes of £25, £20, and £15 brought out four collections of twenty plants, the majority of them of great merit, and when seen arranged along one side of the spacious tent they presented an array of gorgeous flowers and handsome foliage. Mr. Cypher of Cheltenham secured the coveted position of first prizewinner, and his group was truly a grand one, good throughout, with no weak plant here and there as is often noticed. They consisted of *Allamanda Hendersoni*, *A. grandiflora*, *Erica oblata purpurea*, *E. ampullacea* Barnesi, *E. Marnockiana*, *E. Irbyana*, *Ixora Fraseri*, *L. Pilgrimi*, *Croton Sunset*, *C. Johannis*, *C. Queen Victoria*, *Bougainvillea glabra*, *Clerodendron Balfourianum*, *Cycas revoluta*, *C. circinalis*, *Phœnocomma prolifera* Barnesi, *Cordyline indivisa*, *Kentia Fosteriana*, *K. australis*, and *Cattleya crispa superba*. The *Crotons* were grandly coloured, healthy fresh and healthy, and the *Palms* large and beautifully green. Mr. Finch, gardener to J. Marriott, Esq., Queen's Road, Coventry, secured the second prize with a collection in which there were many fine plants, but one or two weak ones, which, no doubt, lessened his chance of taking first honours. Mr. C. Roberts, gardener to A. Nicholson, Esq., Highfield Hall, Leek, who exhibits plants uncommonly well, was third. In the class for nine stove and greenhouse plants Messrs. Pritchard & Sons, Shrewsbury, were easily first with some grand *Ixoras*, *Crotons*, *Ericas*, and *Dipladenias*; large in size, in excellent health, and grandly bloomed. The same firm secured the third prize here, and Mr. Farrant, gardener to Mrs. Jason, Abbey Foregate, Shrewsbury, was second. Mr. Sheppard, gardener to the Misses Bannerman, Roden Hall, Shrewsbury, was first in the class for six stove and greenhouse plants, with fine specimens of *Lapageria rosea*, *Clerodendron Balfourianum*, *Bougainvillea glabra*, *Allamanda Schottii*, *Latania borbonica*, and *Dæmonorops Lewisianus*; Mr. Farrant came second. Ferns made a grand display, many of the specimens being very large and in prime condition. In the class for six exotics, Mr. Cypher was awarded the first prize, Mr. Lambert, gardener to Colonel Wingfield, Onslow, Shrewsbury, second, and Messrs. Pritchard & Sons a close third. In the restricted class for the same number of Ferns, Mr. Lambert was awarded first prize with plants quite equal to those in the other class, Mr. Farrant coming in second; and Mr. Milner, gardener to the Rev. J. Dryden Corbet, Sundorne Castle, Shrewsbury, third. *Dracenas* were large, finely furnished, and highly coloured, Mr. Lambert winning first and third prizes, and Mr. Sheppard the second one. The class for six plants in flower contained many attractive lots, Mr. Cypher being first with a magnificent *Statice profusa*, a grand *Erica Shannoni*, and *Dipladenia amabilis*, *Ixora amabile*, *Erica Thompsoni*, and *Clerodendron Balfourianum*; Mr. Roberts was a very close second; and Mr. Raffells, gardener to H. Lovatt, Esq., Busbury, Wolverhampton, third. *Caladiums* were large, compact, and well coloured, and the prizes for them went to Mr. Raffells, Mr. Sheppard, and Mr. Farrant. The *Coleuses* were conspicuously fine, being pyramidal in form, about 6 feet in height, beautifully trained and furnished, and very highly coloured. The first prize was secured by Mr. Sheppard, the second by Mr. Milner, and the third by Mr. A. Myers, Sutton Lane, Shrewsbury. Messrs. Pritchard had no difficulty in securing the first and second prizes for *Fuchsias*, as their specimens were superb, and Mr. Myers was third. They also were awarded first and second prizes for *Tuberous Begonias* of a very superior type, and Mr. Milner came third. *Double and Zonal Pelargoniums* were in fine condition, the prizes going to Mr. Myers, Mr. Sheppard, and Messrs. Pritchard. The group class of miscellaneous plants, occupying a

space of 100 square feet and arranged for effect, is always a highly interesting feature at this Show. Some who entered did not appear, but Messrs. Pritchard arranged two groups that secured the first and second prizes. They were different in the character of the produce they contained; the first was mainly composed of Maidenhair Fern as an underground, and many choice Orchids relieving it. They were not placed in a flat mass, but had an undulating surface, and the arrangement was most pleasing.

The amateurs' plants were if anything more numerous than in the open classes, and although the individual specimens lacked the size of the others the majority of them were in excellent health, freely developed, and well coloured or bloomed. The chief prizetakers in this section were Mr. H. Owen, The Cedars, Shrewsbury, Mr. W. C. Mansell, Wellington, Mr. J. Barker, Shrewsbury, Mr. W. Wyley, Shrewsbury, Mr. W. Humphreys, Mr. Bourlay, Miss Edith Brookes, and Major-General Herbert. Keen competition existed in the class for twelve plants for table decoration, and Messrs. Pritchard came first with bushy little *Palms*, *Crotons*, &c., in 6-inch pots. Mr. Lambert gained the second and third prizes in a very interesting class.

**CUT FLOWERS.**—Roses were wonderfully good for the season. In the class for twenty-four trusses Messrs. Perkins, Oswestry, were first; Messrs. Burnell, Cambridge, second; and Mr. Murrell, Shrewsbury, third. Messrs. Heath & Son, Cheltenham, were very conspicuous in *Dahlia*s, and secured the first prize for thirty-six varieties; Mr. W. Shaw, Kidderminster, was second and third. Messrs. Heath were also first with twenty-four *Dahlia*s in variety. *Gladioli* were very good from Mr. Humphreys and Mr. G. J. Fox, Shrewsbury. The best herbaceous flowers in competition came from Messrs. Burnell, the best *Phloxes* from Miss Emily Cotes, and the best *Carnations* and *Picotees* from A. E. W. Darby, Esq., Little Ness, Shrewsbury. The bouquets were highly attractive and commanded general admiration; Messrs. Jones & Sons, Shrewsbury, were awarded the first prize for a ball or band bouquet with one in which the colours were beautifully blended and crowding had been strictly avoided. Messrs. Perkins were second with one done up in their well-known style, and Messrs. Pearson & Sons, Chilwell, Notts, were a very good third. The buttonhole prizes were mostly won by Messrs. Perkins and Jones, and so were those for the stand of cut flowers. Some scores of baskets of wild flowers were shown and formed a charming display. The arrangement in many cases was delightful, and the great variety of flowers very interesting. The best were those where flowers, berries, and grasses were artistically combined, and Miss J. W. Watson, Miss Maud Morgan, Miss Kate Jones, and Miss S. A. Phillips were the principal winners.

**FRUIT.**—This was shown in great abundance, and the quality was generally excellent. The Grapes made a grand display, and the collections of fruit were highly meritorious. The main one amongst these with prizes of £10, £6, and £3, was that for twelve dishes, and the competition was very keen. Judging was done by points, and the first prize was secured by Mr. Goodacre, gardener to the Earl of Harrington, Elvaston Castle, Derby. This collection consisted of *Muscat Hamburg* Grapes, large, compact, fairly well coloured bunches, *Madresfield Court*, *Foster's Seedling*, and *Muscat of Alexandria* in fine condition, a grand *Smooth Pine Apple*, *Gros Mignonne Peach*, *Brown Turkey Fig*, *Hero of Lockinge Melon*, *Moor Park Apricot*, *Elrge Nectarine*, *Tartarian Cherry*, and *Transparent Gage Plum*. Mr. Pratt, gardener to the Marquis of Bath, Longleat, came second, his grand Grapes pulling him in; they consisted of huge clusters of *Foster's Seedling*, *Muscat of Alexandria*, *Black Alicante*, and *Black Hamburg*. None of the other dishes in this collection were named, and the *Smooth Cayenne* Pine had been in the wars with its crown. Mr. Roberts, The Gardens, Gunnersbury Park, was third, his Pine being rather weak and *Gros Maroc* Grapes green; but *Foster's Seedling*, *Madresfield Court*, and *Muscat of Alexandria* were good, and *Sea Eagle Peach* of unusual quality. The Earl of Shrewsbury, Ingestre Hall, was awarded an extra prize in this class for a collection in which stone fruits were of exceptionally good quality, but Grapes small.

Exceeding all these in interest, particularly amongst the gardeners, were the collections of six bunches of black Grapes, two bunches of three varieties, with prizes of £10, £4, and £3. Ten lots were staged, and after much careful consideration and inspection the Judges decided in favour of Mr. Goodacre's collection for first place. They consisted of *Muscat Hamburg* large and compact in bunch, *Madresfield Court* very fine, and *Black Hamburg* excellent, altogether a grand stand of seasonable fruit. Mr. Pratt was awarded second prize with very large clusters, well finished, of *Gros Maroc*, *Black Hamburg*, and *Black Alicante*. W. Biddulph, Esq., Ledbury Park, Herefordshire, came third with *Alnwick Seedling*, grandly coloured and large in berry, *Black Hamburg* of fine quality, and *Madresfield Court*, rather deficient in colour. Mr. W. Taylor, gardener to J. Chaffin, Esq., Bath, was awarded a special first prize in this section for a collection consisting of *Lady Downe's*, *Gros Maroc*, and *Black Alicante*. The *Lady Downe's* were unique long thick bunches grandly coloured, and magnificent berries; *Alicante* equally good, but *Gros Maroc* slightly deficient in colour. These would have been difficult to equal in a late Grape class at this or any season of the year, and by giving them a special prize, which they thoroughly merited, the Judges hoped to indicate to the Committee to make more or special provision for late Grapes, which we understand they intend doing.

The class for three bunches of *Black Hamburg* was a strong one, twelve lots being staged. Mr. W. Pratt secured the first prize with large grandly finished clusters, Mr. G. T. Raynes, Rockferry, Birkenhead, being second, and Mr. Lambert, gardener to Colonel Wingfield, Onslow, Shrewsbury, third, with excellent samples. For four bunches of white Grapes Mr. Pratt was first with *Muscat of Alexandria* and *Foster's Seedling*, all bearing the Longleat stamp of high culture. W. Biddulph, Esq., second, with the same varieties, not so large but equally well finished, and Mr. Roberts third with the same sorts in good condition. For three bunches of black Grapes (other than *Hamburgs*) the Hon. C. H. Wynn, Corwen, was first with *Alnwick Seedling*, *Gros Maroc*, and *Black Alicante*, all in the finest possible condition, as were those from Mr. J. Udale, gardener to H. F. Paget, Esq., Elford, Tamworth, which were second, and the third from Mr. Brownhills, Birkenhead, were also fine. The first prize for three bunches of *Muscat of Alexandria* was awarded to Mr. Pratt for grand bunches, very large in berry, but tinged slightly with green. This was rather noticeable in the

second prize lot from Mr. J. T. Harris, Stone, and the third from Mr. C. L. Campbell, Ross. In the other variety of white, the Hon. C. H. Wynn was first with fine samples of Duke of Buccleuch, spotless and beautifully ripe. Mr. Milner, gardener to the Rev. J. D. Corbet, Snndorne Castle, Shrewsbury, was second with Buckland Sweetwater, large in bunch, fine in berry, and capable of holding their own with the same variety anywhere. The amateurs' Grapes were best from Mr. W. Adams, Shrewsbury, Mr. Barker and Mr. Sander, Wellington.

In the nine dishes of fruit class some excellent produce was staged, the first prize going to Mr. Lambert for superb Black Hamburg and Muscat of Alexandria Grapes, Best of All Melon, May Duke and Bigarreau Cherries, Royal George Peach, Darwin Nectarine, and a fine dish of Apricots—a beautifully clean collection, and the same may be said of the second prize lot from Mr. Sheppard, gardener to the Misses Bannerman, Shrewsbury, whose Grapes were particularly good and Peaches excellent. Mr. Milner was a very close third. All the fruit in these collections exhibited signs of high culture.

The collections of hardy fruits were not up to the usual high standard at these shows, the Rev. H. V. Russell, Mr. Dick, and Lord Berwick being the winners. There were fourteen dishes of Peaches staged, the first prize going to Mr. Gilman, of Ingestrie, for magnificent fruit; the Rev. H. V. Russell came second, and Mr. Redman, Shrewsbury, third, all showing exceedingly well. Nectarines also numbered fourteen dishes, Mr. Gilman being first with grand samples of Victoria, and the Hon. C. H. Wynn and Mrs. Darby secured the other prizes. Apricots numbered seventeen dishes, and Mr. Martin, Ledbury, Herefordshire, secured the first prize. The first prizes for both green or yellow and purple or red Plums were awarded to Mr. Blair, gardener to the Duke of Sutherland, Trentham, for Jefferson's and Kirke's of the very highest excellence. Green-fleshed Melons numbered twenty-four, the majority of the fruits were very showy, and the first prize went to Mr. Goodacre for a fine fruit of Best of All, Mr. Dick being second with Hero of Lockinge. Scarlet-fleshed varieties numbered twenty, and Mr. H. Owen was first with a fruit named Little Heath, and Lord Berwick second with Bloxholm Hall. Cherries were very fine, and numbered twelve dishes, the prizes being awarded to Mr. Phillips, The Mount, Shrewsbury, Lord Berwick and Miss Emily Cates.

VEGETABLES.—Large and keen competition occurred everywhere amongst these, and many of the samples staged were unique. Messrs. Webb & Sons, of Wordsley, offered prizes of £5, £3, £2, £1, and 10s. for eight distinct kinds of vegetables, and upwards of a dozen fine collections were staged. This was the centre of attraction amongst the vegetables, and Mr. Lambert, of Onslow, was a clear first with wonderful dishes of Webb's Sensation Tomato, Webb's Colossal Leek, Autumn Giant Cauliflower, Red Celery, Potatoes, Peas, Kidney Beans, and Tripoli Onions. Mr. J. C. Waite, Glenhurst, Surrey, was placed second, and Mr. Milner was a very close third; the other prizes going to Mr. Craford, Newark-on-Trent, and Mr. Sheppard, both of whom staged fine produce. The Society offered prizes for twelve dishes of vegetables, and the first of these was again secured by Mr. Lambert with first class produce; Mr. Milner came in second here in grand form, and Mr. Waite secured the third prize. Potatoes were well represented, Mr. Lambert and Mr. Milner taking the lead in the large collections. Mr. Goodacre was first for a dish of Tomatoes, Mr. Battie, Overton, first for Peas; Mr. W. H. Long was first for spring-sown Onions, and Mr. Lambert the same for autumn-sown specimens. The prizewinners for Cucumbers, Canliflower, Celery, French Beans, Carrots, Parsnips, &c., included the Rev. J. H. E. Charter, Mr. Lambert, Mr. Waite, Mr. F. J. Lowe, Mr. Sheppard, and Mr. J. S. Phillips. The cottagers had a huge tent to themselves, and it was brimfull of excellent produce, which commanded much attention; in fact, many of the specimens here were equal to what we often see staged by the best professional growers.

SPECIAL EXHIBITS.—These were very plentifully displayed, and of a highly interesting description. Messrs. Pitchard & Sons, Shrewsbury, were large exhibitors of table plants, cut flowers, and general nursery stock. Messrs. James Dickson & Sons, Chester, had a fine table of small specimen plants, many stands of cut Roses, hardy flowers, Dahlias, Gladiolus, &c., and a grand batch of their fine new Carnation Mrs. Reynolds Hole. They had also a large group of young trees in the open. Mr. Burrell, Shrewsbury, was a large exhibitor of out and indoor plants and flowers, and the small Apple trees bearing immense crops of fruit which he displayed attracted the attention of all. Lord Grosvenor was amongst the best of them, but they were all good. Messrs. F. & A. Dickson & Sons, Chester, filled several tables with choice plants from their nurseries, and the cut flowers staged by this firm were varied and excellent. Messrs. Jones & Sons, Shrewsbury, had a very fine group of plants. Messrs. Hans Niemand & Co., Birmingham, sent a fine lot of Carnations and Picotees in a cut state, also Mauve Beauty Stock. Mr. Verdegan, Birmingham, made a grand display of Roses and herbaceous cut flowers. Messrs. Webb's stand contained many pictures of their productions and other information bearing on their great midland seed establishment.

#### MAIDENHEAD HORTICULTURAL SOCIETY.

THE ninth annual Exhibition of this Society was held in the extensive and well-kept grounds of Braywick Lodge, kindly lent by J. Hibbert, Esq., on Thursday, August 18th. There was a division open to all comers, another reserved for amateurs, and a third for cottagers, with prizes for ladies and children, and a series of special prizes. The following is a *resumé* of the most important awards:—

Stove and greenhouse plants and groups, Class 1.—Eighteen handsome foliage plants in 8 inch pots: First, Mr. T. Lockie, gardener to G. O. Fitzgerald, Esq., Oakley Court, Windsor, for a collection of clean healthy specimens. Second, Mr. J. Hughes, gardener to H. D. Paravicini, Esq., Heathfield, Bracknell. Equal third, Mr. J. Wells, gardener to Mrs. Ravenhill, Fernhill, Winkfield, and Mr. G. Elliott, gardener to J. Hibbert, Esq. Six stove and greenhouse plants, three in flower, three foliage: Mr. A. Aitken, gardener to Mrs. Meeking, Richings Park, Iver, was first, showing a fine *Kentia Fosteriana*, *Allamanda grandiflora*, *Bougainvillea glabra*, a fine *Croton majesticus*, *Plumbago capensis*, and *Croton Johannis*. There was no other competitor. Mr. Aitken also had a walk over with six stove and greenhouse Ferns, showing good examples of *Microlepia hirta cristata*, *Pteris scaberula*, *Adiantum amabile*, *A. concinnum latum*, *Davallia Mooreana*,

and *Gymnogramma Alstoni*. For one specimen stove or greenhouse plant in flower Mr. Aitken was first with a fine *Allamanda Hendersoni*; Mr. Hughes second with an excellent specimen of *Lilium lancifolium rubrum*; and Mr. Goodman, gardener to C. Hammersley, Esq., Abney House, Bourne End, third with *L. auratum*. In a corresponding class for a foliage plant Mr. Aitken again took the first prize with a grand *Croton Queen Victoria*, Mr. Hughes being second with *Dracaena australis*, and Mr. Lockie third with *Kentia Fosteriana*. For six plants for table decoration Mr. Lockie secured the premier award, the second prize going to Mr. G. Hiatt, florist, Herschel Street, Slough, and the third to Mr. Elliott. Mr. Goodman secured an easy victory in the class for six Tuberos Begonias, showing fine, well-flowered specimens. Mr. R. Owen, Floral Nursery, Maidenhead, was second; and Mr. Aitken third. Mr. G. Hopkins, gardener to G. W. Burrows, Esq., The Elms, Cookham, was first with six Cockscombs, his plants bearing fine comb. Mr. W. Friend, gardener to W. Lambert, Esq., Cookham, was a creditable second, and Mr. Lockie third. There were four lots of six Coleuses, Mr. Hopkins easily accounting for the first prize, and being followed by Mr. King (second) and Mr. S. Squelch, gardener to J. C. Wootton, Esq., Boyne Grove, Maidenhead (third). For a group of plants occupying a space of 12 feet by 10 feet, Mr. Aitken took the first prize. His arrangement was composed of *Liliums*, *Gladioli*, *Gloxinias*, *Impatiens Sultanii*, Orchids, and fine-foliage plants, on a groundwork of Maidenhair Ferns, and was very attractive. Mr. G. Hiatt was second, and Mr. Elliott third. For a smaller group (6 feet by 5 feet) Mr. A. Griffiths, gardener to Colonel Harvey, Springfield, Taplow, was first, Mr. T. Lockie second, Mr. Hughes and Mr. Stirling equal third, and Mr. Owen fourth. There was not much to choose between several of these groups.

CUT FLOWERS.—These must be dealt with briefly. For twelve Roses Mr. Walker, Thame, was first, Mr. Elliott second, and Mr. Griffiths third. For twelve Dahlias Mr. Walker was again first, Mr. Carding second, and Mr. Squelch third. For six bunches of single varieties Mr. Carding was first. For twelve Asters, any varieties, Mr. Griffiths was first and Mr. Elliott third, the second prize card being missing. For twelve Zinnias Mr. Elliott was first, Mr. Hughes second, and Mr. Walker highly commended, the third prize card being missing. Prizes for bridal bouquets and buttonholes were won by Miss Semple and Messrs. Hiatt and Elliott.

Fruit was well and plentifully shown, fourteen classes being provided. The principal one was for a collection of six dishes, and the first prize went to Mr. G. Goodman, who showed Black Hamburg Grapes, Victory of Bristol Melon, Oullins Golden Gage Plum, Dagmar Peach, Dryden Nectarine, and Brown Turkey Figs. Mr. Cakebread, gardener to Sir Philip Rose, Rayners, was a very good second, and Mr. Aitken third. For a collection of four dishes, Pines excluded, Mr. Lockie was first, showing Buckland Sweetwater Grapes in good condition, excellent Castle Kennedy Figs, Magdalen Peaches, and Beauty of Windsor Melons. Mr. D. Paxton, gardener to the Hon. C. J. Irby, Hitchen Grange, was a good second, and Mr. Woolford, gardener to J. Macmeiken, Esq., Little Missenden Abbey, third. For a collection of four fruits grown in the open air Mr. Wells won with Musch Musch Apricot, Green Gage Plums, Rivers' Early Peach, and Mottled Bigarreau Cherries. Mr. Goodman was second, and Mr. Paxton third. Mr. T. Osman, gardener to L. J. Baker, Esq., Ottershaw Park, Chertsey, secured the premier award for Black Hamburg Grapes, showing large, well ripened bunches. Mr. Cakebread was second. Mr. Hopkins third, and Mr. Wells fourth, there being seven contestants. For the three bunches of any other black kind Mr. Cakebread won with grand bunches of Madresfield Court. Mr. Osman was second with almost equally meritorious bunches of Black Alicante, and Mr. Wells third with Cooper's Black. For three bunches of White Muscats, Mr. Osman secured the chief prize with splendid examples of Muscat of Alexandria, Mr. Cakebread second, and Mr. Wells third, both with the same variety. Two others exhibited. For any other white kind Mr. Osman was first with excellent examples of Foster's Seedling; Mr. Wells second with Buckland Sweetwater, and Mr. Hughes third with Foster's Seedling. Mr. Lockie secured the first place for six Peaches, winning with very fine fruits of Magdalen; Mr. Draper, gardener to Mrs. Shepherd, Manor House, Little Missenden, following with Bellegarde; Mr. Chambers, Westlake Nurseries, Isleworth, being third. In the corresponding class for Nectarines, Mr. Aitken was first with Lord Napier, and Mr. Goodman second with Dryden. Mr. Woolford won with a green-fleshed Melon, showing Fidler's Defiance, Mr. Elliott being second. For a scarlet-fleshed variety Mr. Woolford was again first with Blenheim Orange; Mr. J. Hohley, gardener to E. Dickens, Esq., Woolley, Firs, Maidenhead, being second, and Mr. Lockie third. For a dish of Plums Mr. Goodman was first, and Mr. Wells second. For nine dessert Apples Mr. J. Moore, The Gardens, Wray Court, Maidenhead, was first; Mr. Davis, gardener to Major-General Davis, Lowood, Maidenhead, second, and Mr. King third. In the corresponding class for culinary varieties Mr. Goodman was first, Mr. Elliott second, and Mr. Hughes third.

VEGETABLES.—Nine classes were provided. Mr. Lockie had the best brace of Cucumbers, showing Royal Windsor, Messrs. Elliott and Quelch, gardener to the Lady Superior, House of Meicy, Clewer, following. The last named gained the chief award for three sticks of Celery, Mr. Harris being second. Mr. Lockie won with Peas, showing a good dish of Webb's Chancellor, Mr. Cakebread being second with Prodigy, and Mr. Griffiths third with British Queen. For six dishes of Potatoes, distinct, Mr. Woolford was first, Mr. Wells second, and Mr. Skarratt, gardener to Miss Harrison, third. In the class for twelve kidney Potatoes Mr. Elliott was first, Mr. Aitken second, and Mr. Paxton third, the prizes in the corresponding class for round tubers going to Messrs. Skarratt and Woolford. The first prize card was not affixed. Mr. Woolford was first with twelve Onions, Mr. Draper second, and Mr. Hughes third. Mr. Quelch won with twelve Canliflowers, followed by Mr. Hughes; and in the last class, that for twelve Tomatoes, Mr. Lockie was first, Mr. Quelch second, and Mr. Woolford third.

SPECIAL PRIZES.—Prizes were presented by Messrs. Sutton & Sons, Reading, for the best collection of vegetables, six distinct varieties, to include three mentioned in their "Amateurs' Guide" for 1887. No less than nine collections were staged, and they comprised produce of considerable excellence. The first prize went to Mr. G. Elliott for a very fine collection, composed of Autumn Giant Cauliflower, Sutton's Improved Telegraph Cucumber, Matchless Carrots, very good; Giant Rocca Onions, also excellent; Reading Perfection Tomato, and Seedling 21 Potato. Mr. H. Cake-



bread was second, showing Leviathan Onion, Sutton's Gem Carrot, and Cosmopolitan Potatoes well. Mr. W. Woolford was a creditable third, Mr. G. Goodman fourth, and Mr. J. Hughes fifth. Messrs. Webb & Sons, Wordsley, Stourbridge, offered three prizes for a collection of six vegetables, to include at least two named in their spring catalogue. Seven collections were in competition, a grand lot from Mr. T. Lockie securing the first prize. Webb's Perpetual Bearer Cucumber, New Intermediate Carrot, Jubilee Tomato, and Chancellor Peas were finely shown, also Giant Rocca Onions and Cosmopolitan Potatoes. Mr. G. Elliott was a good second, and Mr. D. Paxton third, also showing well. Mr. Lynn of Maidenhead offered three prizes for the best nine bulbs of Exhibition Onions, and they were won by Messrs. Woolford (first), Elliott (second), and G. Hopkins (third).

Good produce was shown in many of the amateurs' and cottagers' classes, but they were too numerous for details of the awards to be given here.

#### WELSH SHOWS.

HORTICULTURAL Shows are very common in South Wales during the month of August, and are invariably good and well patronised. Horticulture is in a very flourishing state amongst all classes in the Principality, and, with perhaps the exception of the Eisteddfods, there are no gatherings so well attended as the flower shows.

CARDIFF.—This was held in the Sophiah Gardens on August 10th. It was a most successful show. The exhibits were placed in tents disposed here and there amongst the trees, and had a very pretty effect. Mr. Cypher of Cheltenham gained the first prize for twelve stove and greenhouse plants. They were all grand specimens. Mr. G. Jones, a local exhibitor, was a good second. In the next class, which was for fine-foliage plants, Mr. Pettigrew, Cardiff Castle, was an easy first, Mr. Cypher coming second. The Cardiff Castle plants were excellent, and the win was a popular one. Fuchsias were very good, but not so fine as they were last year. Mr. J. Watson had the best. Exotic Ferns from Sir George Elliott and Mrs. Steads were splendid. In the amateur plant classes Mr. Pettigrew, Mr. C. H. Williams, Mr. C. Thompson, Colonel Page, Mr. C. Waldron, and Mr. W. L. Blake were the principal prizewinners. Mr. Ralph Crossling, The Nurseries, Penarth, and Mr. Stephen Treseder of Cardiff were the chief exhibitors of Roses. In variety and quality of bloom their stands would have been hard to beat at this season. Messrs. Heath & Son, Cheltenham, exhibited some excellent Dahlia blooms, and had no difficulty in securing the first prize. Mr. G. M. Traherne was first with Phloxes and some other flowers, and the dinner tables were a grand feature of the Show. They were laid out with dessert, and adorned with flowers. Miss C. Hill obtained the first prize for table confined to the ladies of Glamorganshire with a very pleasing arrangement, in which dark Carnations held a prominent place. Mr. Phelps of Cardiff had a more elaborate display on the open table, but it merited the first prize.

Fruit was staged extensively, and, as a rule of high quality. Mr. Hawkins, gardener to Colonel Turberville, Ewenny Priory, Bridgend, was first for the leading collection. His Muscat of Alexandria Grapes and Peaches and Pears were extra good. Mr. Pettigrew took all before him in Pine Apples, being first for a collection of Pines, first for a Queen Pine, and first for a Pine of any other variety. Mr. Morris, gardener to A. P. Vivian, Esq., Glanafon, Taibach, was second for a Queen, with a fine fruit rather too ripe. Mr. Silk, gardener to T. M. Franklen, Esq., St. Hilary, Cowbridge, was first for three bunches of Muscat of Alexandria Grapes with huge bunches and fine berries, grandly ripened. Mr. Hawkins was second with small bunches extra well coloured. Lord Aberdare was first for Black Hamburgs, and Major Howell second. In any other black, Mr. G. M. Traherne was first with Madresfield Court, and Mr. Silk second with Gros Maroc, large in bunch, enormous in berry, and very well coloured. Mr. Hawkins secured the prize for a collection of Grapes. Melons were well shown by Messrs. Griffen, Cardiff, Mr. Hawkins, Mr. Pettigrew, and Mr. Gibson. Plums, Apicots, &c., were rather scarce.

Vegetables were plentiful, and in many instances very fine. Messrs. Webb & Sons, of Stourbridge, offered prizes for six varieties, and the first prize was secured by Mr. J. Muir, Margam; the second by Mr. G. M. Traherne, and the third by Mr. G. Rees, Merthyr Mawr, Bridgend. The next collection was that of nine dishes, and Mr. J. Muir again secured first prize with produce of the greatest excellence. Sir George Elliott was second and Mr. Silk third. The competition in the single dishes of vegetables was very keen, the principal winners being Mr. Muir, Mr. Morris, Mr. Moor, Coedriglan, Mr. Silk and Mr. J. Watson.

NEATH.—This is a small town in mid-Glamorgan. For several years past it has produced an excellent horticultural show, and the one held this year on the day succeeding Cardiff proved the best of the series. The Committee are mostly amateurs with a great love for gardening, the arrangements for the Show admirable, and the conducting of it most spirited. Mr. Cypher exhibits annually at it, and his first prize group this year contained fine specimens of foliage and flowering plants, but he was closely followed by Captain Mansfield, St. Clears, Carmarthenshire, who was second with very large plants; and Mr. Worgan, gardener to A. Gilbertson, Esq., Pontardawe, exhibited so well in this class as to secure an extra prize. His plants were small but uncommonly healthy, and indicated the foundation of what would easily prove a formidable lot. Exotic Ferns were exceedingly fine, the best coming from D. Bevan, Esq., Cadoxton, Neath, and P. W. Flower, Baglan Lodge, Briton Ferry. Roses were shown extensively in the open classes by Mr. Crossling, and Mr. Cypher's epergnes were the best. The amateurs' classes were well filled with plants more remarkable for their good condition than great size. Howel Gwyn, Esq., Dyffryn, Neath; Mr. Worgan, Mr. J. H. Rowland, Mr. H. P. Charles, Mr. Moon, and several others in the locality staging well, but flowers were highly attractive, Mr. F. W. Aylwin, Mr. J. M. Moore, Mr. D. Davies, and Mr. J. Pile being the chief prizewinners.

The vegetables did not appear to have experienced any of the backward results attending an exceedingly dry season, as they were staged in enormous quantities and of capital quality. Mr. Morris, Glanafon; Mr. Hawkins, Ewenny; Mr. Dan Morris, Carmarthen; Mr. Speck, Llanelly; Mr. Moor, Coedriglan, Cardiff; Mr. Worgan, and Mrs. Palmer, Rheold, Neath, were amongst the principal prizewinners.

The Grapes from St. Hilary were very conspicuous amongst the fruit, and Mr. Hawkins staged finely ripened fruit in this section. The best

Melons came from Mr. Worgan, the best Nectarines from Mr. Morris, and much good fruit was shown by Mr. D. Bevan and others. Brief as these notes are they deal with a grand show.

LLANDOVERY.—This is a small town situated in one of the most picturesque parts of Carmarthenshire. It is well above the sea level, beautifully surrounded with hills and undulating ground, and is noted for its health-giving resources, being close to the Welsh "Wells" so largely patronised for their medical properties. No more delightful situation could have been chosen for a show, and although the Exhibition held on August 16th was the first it was of great merit and argued well for the establishing of an annual show. The Committee, although new to the work, carried out their duties admirably. Captain Mansfield staged plants very extensively and was the chief prizewinner. Miss Jones, Ystrad House, Mr. J. M. Sinnett, Mr. Moreton, and Dr. Lewis were the chief local prizetakers in plants; Captain Mansfield, Mrs. Norton, Llanelly, Mr. Harding, Llanelly, Mr. J. M. Sinnett, and Miss Davies in flowers; and Major Thomas of Llandilo, Mr. D. W. Jones, Cardiff, and Mr. J. C. Richardson, Llandilo, in Grapes. The Muscat of Alexandria from the latter gentleman would have won at a much larger show. Vegetables appeared in large quantities, and the quality throughout reflected much credit on their cultivators.

ABERDARE.—This Show, held on the 18th inst., has been established for some years, and now ranks amongst the best in South Wales. It is managed with great spirit, and no effort is wanting by the Committee to make it a success; indeed, it is a great pleasure to come in contact with such officials, as they are all earnest in promoting good gardening. Mr. Cypher always appears here and sets a good example to others in the excellency of his groups, which invariably secure first prize; Captain Mansfield followed closely, and Mr. Cumley, gardener to J. Lewis, Esq., Abernant, was third. Ferns were very good from Mr. R. H. Rhys, Plasnewydd, and Mr. Bevan, Neath, and Geraniums and Fuchsias by Sir George Elliott, Major Howell, and Captain Mansfield. Mr. Ralph Crossling was again an extensive exhibitor of Roses. Mr. W. Treseder, Cardiff, and Mr. J. N. Moore, Neath, staged some excellent Dahlias, and the Asters, Phloxes, Verbenas, &c., were very attractive.

The fruit classes were filled and contained some fine examples. For nine dishes the Misses Rous, Cardiff, was first and Captain Mansfield second, and in the class for six dishes Mr. Comley came first with fine Grapes, a good Queen Pine, and grand Peaches; Sir George Elliott was second, and Major Howell third. Black Hamburgs were extensively shown, the first prize going to Sir George Elliott. Mr. Stone, gardener to Lord Aberdare, was first for Muscat of Alexandria, and Mr. Comley was first for any other kind of black Grape with fine samples of Madresfield Court, and in the any other white class the first went to Sir W. T. Lewis for fine bunches of Foster's Seedling. Mr. J. Croft, Resolvent, also exhibited fine Grapes, and the fruit classes were the best we have seen at this popular Show. The vegetables in both the gardeners' and cottagers' sections were very good, and the whole proved a most instructive Exhibition.

#### THAMES DITTON HOUSE.

PERHAPS of the waterside residences within easy distance of the great City this may fairly claim to be one of the most beautiful and pleasantly situated. The house is embowered in a wealth of fine trees, to a few of which we shall briefly allude, the spacious and well-kept lawn overlooking the Thames, the effect of the picturesque view being considerably heightened by the fact that across the water is the Home Park adjoining Hampton's historic pile.

Referring to some of the trees, that admirable subject for water margins, the Weeping Willow, is represented by some very fine and graceful examples, and wending our way towards the mansion we note a magnificent specimen of *Platanus orientalis*, some 80 or 90 feet in height, and well clothed with foliage. It has been remarked that this fine tree flourishes best and attains the greatest size where the roots have access to water, the cause of its success, doubtless, at Thames Ditton. A fine Beech, too, arrested attention, its circumference being 270 feet, the branches sweeping upwards to a considerable height, forming, as it were, stately arches.

We noticed hereabouts what may be called a successful operation in tree moving. A fine example of the single scarlet Thorn had long been an eyesore to the owner, W. F. Hume Dick, Esq., on account of its being planted so close to others that it lost its individuality. Last November it was decided to have it removed—rather a risky proceeding—to a more open part of the lawn. This was accordingly done, and that the process was entirely successful is now evident by the flourishing condition of the tree, and Mr. W. Palmer, Mr. Dick's able head gardener, may be congratulated accordingly.

In the pleasure ground we were much struck with the natural style of the planting, affording an indeed pleasant contrast to the stereotyped system sometimes seen. The grounds, too, are so planted that we do not see the whole at once. There are some charming peeps that one comes upon here and there as pleasant surprises; and embowered as we are at points with a wealth of cool and pleasing foliage, we might well imagine that we were in the heart of some fair domain far away in the country, and not within a few miles only of London's din and roar.

On a wall near the mansion we noted a fine example of *Magnolia grandiflora* (Exmouth var.) wreathed with its noble blossoms, the fragrance emitted being almost overpowering. In an effectively planted walk leading to the carriage drive we noted some particularly handsome specimens of *Cupressus Lawsoniana* towering to a great height and forming a conspicuous feature. Variegated forms of *Accr Negundo* dotted here and there help to light up this portion of the grounds in a very pleasing way. That magnificent evergreen tree, the Cedar of Lebanon, is represented by a stately specimen that the late storms have left their mark upon.

The rosery is an attractive feature. Mr. Palmer's practice, in order



to insure a quantity of good blooms, is to peg down the strong shoots, made from the base of the plant, forming a kind of arch—a somewhat effective arrangement.

Amongst the bedding plants, of which there are a quantity grown and effectively disposed, we noticed a good Coleus named Palmer's Favourite, a sport from a very old sort named Taylor's Pet, upon which it is a great improvement.

The roof of the conservatory attached to the mansion is covered with a very fine Maréchal Niel Rose that had borne over 2000 blooms this season. We also noted in this structure a very good example of the Japanese Quince, *Eriobotrya japonica*. Specimen Azaleas were looking well for next season's flowering, and the usual plants grown for conservatory decoration were also well represented.

In the fruit department houses are devoted to the culture of Grapes, Black Hamburgh and Foster's Seedling being the standard sorts grown, and these are admirably done. There are three Peach houses, lean-to. From a tree of Yellow Admirable some twenty dozen fruits had been

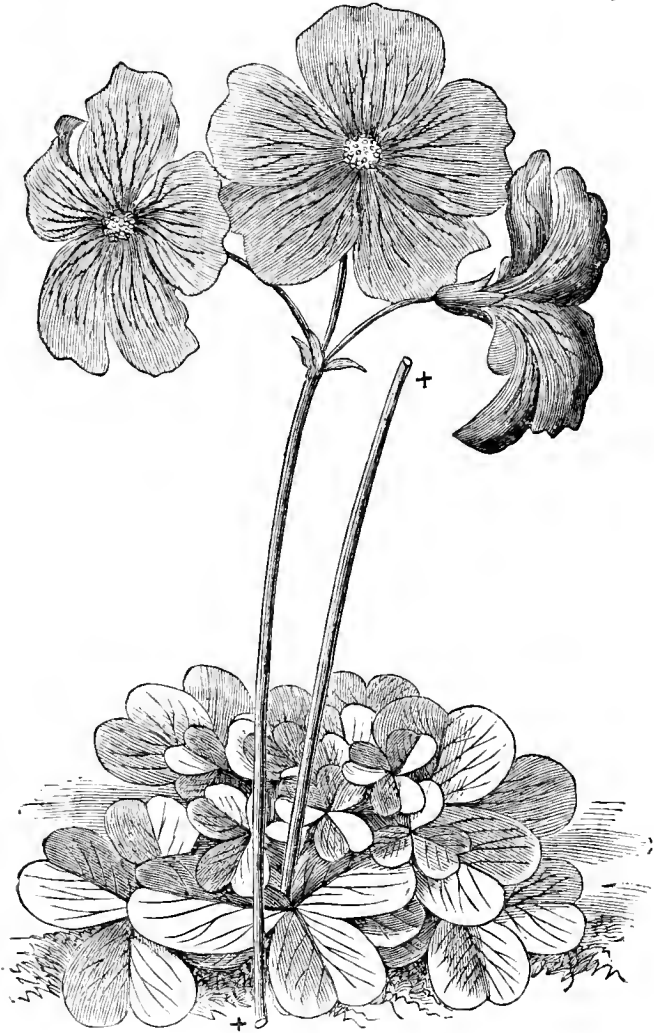

Fig 21.—*Oxalis brasiliensis*.

taken. Barrington is much esteemed here. In these houses some young trees planted last autumn are doing wonderfully well. In the early Peach house some fine examples of Sutton's Perfection Tomato, bright, solid, and beautiful, arrested attention. In a keen competition at Chiswick recently, a dish from here gained first honours. Melons are great favourites. We noticed a very promising variety named Thames Ditton Hero, raised here. It is of excellent flavour, and is a cross between Scarlet Premier and High Cross Hybrid. It is one of the hardest and most prolific sorts grown, not less than fifty fruits having been cut from two plants occupying one light. We believe that it has made its appearance at several of the local shows this season with distinction, and we shall doubtless hear more about it another season.

In the kitchen garden we noticed some of the finest Asparagus beds we have ever seen, only planted last April twelve months. We believe that it is Mr. Palmer's intention to contribute to the Journal some notes explaining the system of culture that has produced such satisfactory results. The favourite Pea grown is Sutton's Duke of Albany, of which Mr. Palmer has a very high opinion. Veitch's Mammoth Scarlet Runner Bean was seen in perfection, and Autumn Giant Cauliflower. A hint regarding the clubbing to which Cauliflowers are sometimes subject may not be out of place here. If the plants are inclined to club, the practice, and a successful one, carried out here with a view to its prevention, is to cover the ground around the roots with a mixture of soot and native guano, then water in well, afterwards either mould up with earth or mulch with dung, the latter preferred. The good effect of this course of procedure is soon evident, the ground being full of young roots from the main stem. Nourishment is also given by this system to the plants and good root action insured—that great preventive of clubbing. Apples are a good crop this season, Plums and Pears average. Apricots appeared

to be plentiful, for on a wall we noted some fine fruit. Cherries, too, on walls, fine, and plenty of them. In making a tour of the garden we came across some good beds of Violets, the health of the plants being, doubtless, attributable to the damp shady situation in which they are planted, the sorts grown being The Czar, Marie Louise, Victoria Regina, Comte de Brazza, De Parme, and Belle de Chatenay.

In a range of glass in the kitchen garden, divided into two plant houses, we observed some fine specimen Coleuses highly coloured, some good examples of Pelargoniums well flowered, and numerous Egg Plants carrying their healthy characteristic fruits. What a fine wall plant *Ficus* is! quite a dense mass of it forms a pretty and effective feature in the house. The useful and fragrant *Stephanotis floribunda* covering the roof was noticeable on account of its just coming into flower again for the second time this season. Much more might be said did space permit of this pleasant Thames side retreat, but enough has been written to show that advantage has been taken of its favoured position to render it enjoyable by its owner, who has done much to improve the property since it came into his possession some twenty years ago, and it is a credit to his gardener, Mr. Palmer.—B. C.

### OXALIS BRASILIENSIS.

MANY species of the genus *Oxalis* are pretty enough to be worth growing as greenhouse plants, and one of the prettiest of them is that here figured. It was exhibited recently by the Royal Gardens, Kew, at one of the fortnightly meetings of the Royal Horticultural Society at South Kensington, several pans filled with plants bearing umbels of rich rosy purple flowers being shown. The exceptional size of the flowers and their attractive colour, as well as their abundance on the plants, revealed in this species a greenhouse flowering plant worthy of attention. It has Tulip-shaped tubers about 1 inch long, short-stalked leaves of the ordinary Wood Sorrel type, and graceful peduncles about 6 inches high, bearing umbels of from three to eight flowers. It should be planted in rich loam in well drained pans or pots, and started into growth in February. The flowers are developed early in June. By August the leaves will have withered, and the tubers should then be kept dry till the return of February. About six tubers in a 5-inch pot are sufficient; larger pans or pots, if used, may have the tubers planted about 2 inches apart. The secret of growing and flowering many of the exotic *Oxalises* is in allowing them plenty of pot room, thin planting, rich soil, a good dry rest, and, whilst growing, a position near the glass in full sunshine in a greenhouse. *O. brasiliensis* is, as the name denotes, a native of Brazil, from whence tubers were sent to Kew some years ago by the late Charles Darwin. The late Mr. Giles Munby grew a fine collection of *Oxalises*, and many of the kinds grown by him are now at Kew, where every spring they make an effective display with their white, yellow, pink, and red flowers. *O. variabilis*, *O. speciosa*, *O. lutea*, *O. floribunda*, and that here figured we have noted as being particularly pretty pot plants.



### KITCHEN GARDEN.

**AUTUMN ONIONS.**—This is the term usually applied to the Giant Rocca type of Onion that is sown in the autumn and grown during the winter to bulb in spring or early summer. They are a grand class of Onions and should be grown in all gardens. We have experimented year after year with the object of finding out the most suitable date to sow them, and have come to the conclusion that from the 25th to the 30th August is a safe period in the south. By safe we mean this:—If they are sown too early many of them will run to flower in the spring and never bulb well; and, if sown too late they are very apt to suffer in winter, by being too small as well as being late in bulbing, but the point to aim at is to make sure of the majority bulbing without a hitch, and if sown during the period we name this will be secured. As to the best variety, they are all good if well treated. The Giant Rocca is an old one and good. The White Tripolis are quick in growth, but not very hardy; a firm strong rich soil suits them best. If sown in rows many of them may be allowed to remain in the seed ground to bulb; these and the others can be drawn up for use as salad in winter or to transplant in spring. As a rule the best bulbs are produced by the plants that are left undisturbed in the seed rows, and this is particularly the case if the ground is well manured before sowing. We manure heavily, and dress at the same time with a good quantity of soot to prevent grubs from doing harm. An eye should always be kept to this. The best way of sowing we have tried is to draw drills 18 inches apart, 2 inches deep, and not sow too thickly. They are covered, trodden down with the feet, and the

ground then rolled. A firm soil suits them at all times, some of our best bulbs this season weighed 20 ozs.

**SPRING CABBAGE.**—The young plants do not grow quickly. Where rain is still deficient they should be watered thoroughly now, and again when necessary. Where seed was sown early and the plants are now 3 inches or 4 inches high, water them well in the seed bed, then draw the largest of them and plant in a good piece of ground. The rows should be 2 feet apart, and 18 inches from plant to plant suits most varieties. We hear of many winter greens having failed this season, and by planting the largest of the Cabbage plants, now many of them may become ready for cutting by December should the autumn and early winter prove wet and mild. If dry weather succeeds planting give water copiously until they are established.

**LATE TURNIPS.**—We are still dissatisfied with our crops, have therefore sown again this week, and we would advise all who have any prospect of being deficient of this important crop to do the same.

**TOMATOES.**—The majority of our indoor plants have been cleared out, as those in the open air are ripening fruit freely, and our supply from them until frost comes is insured; but the dry weather with the weight of fruit is very trying to them, and large quantities of liquid manure are requisite for their support. They are not growing very freely now, and require little pruning, but where the growths are luxuriant they should be pinched closely.

**KIDNEY BEANS IN FRAMES.**—It is now too late to sow Kidney Beans in the open ground, but as there are many empty frames in gardens at the present time, a quantity of *Ne Plus Ultra*, or some other dwarf sort, should be sown in them. If they contain soil from which Carrots have been cleared, or any other vegetable, it may not be necessary to add more soil, but level it down, clear it of weeds, then open up drills 15 inches apart and 3 inches deep, and sow the seed in them thinly. Give water if necessary, and do not put on the lights until frost or a low temperature threatens to injure them. These Beans will fruit much later than any in the open, as the lights can easily be drawn over them at night in October or November, and all who grow their latest Kidney Beans in frames will find them a most valuable crop.

**LATE CELERY.**—As a rule spring Celery is planted too early. There is plenty of it ready now, and the winter stocks are well forward, but no one can expect to have good Celery next spring where it is almost full sized now. The best way of securing late Celery is to plant rows of it about this time, allow it to remain unearthed until winter to keep it hardy, and it will turn out fine and firm in the spring months. The best spring Celery we ever had was planted on the level ground on a south border. We placed some bracken between the rows in winter, and earthed the plants up in February by placing old leaf soil between them, and the produce was excellent.

**OLD CROPS.**—Many crops are now becoming old and past use. The second early Cauliflowers are almost over. Peas, excepting the late ones, are withered up. Dwarf Kidney Beans have become too old on the early rows, and many things may be cleared off, but this is not always done promptly. It is no uncommon occurrence for crops which were over in August to be left until September or October before clearing them off; this is very unprofitable, as old crops of the kind indicated are absolutely worthless, yet exhaust the land. The better way is to clear them off as soon as they are too old for use, and their place may always be filled with some kind of young crop.

#### FRUIT FORCING.

**PINES.**—Suckers from the summer-fruiting plants will soon be ready to repot. It is well to divide the plants into two batches; one, the strongest plants, should be shifted into their fruiting pots as soon as ready, employing 10 or 11-inch pots according to kind, affording them a position near the glass in a light airy house, keeping them gradually growing through the winter. The plants so treated will be readily excited into fruit next May or June, and will afford a good supply in late summer or early autumn. The other plants, suckers from the summer fruiters, not large enough to shift into fruiting pots, winter in the 7 or 8-inch pots, transferring them to the fruiting pots as soon as ready in the spring, which, with suckers of Smooth-leaved Cayenne that were started last March, will provide a successional supply of fruit through the winter months.

A re-arrangement of the plants should now be made in order to separate the fruiting from the non-fruiting plants, as many of those that were started from suckers of last summer's fruiters will have fruit swelling off. Those plants not fruiting will have completed the growth, and should have air very liberally for the next six weeks, when the temperature exceeds 80°, maintaining the bottom heat steadily at 80°; and all plants well established—*i.e.*, well rooted, should have a bottom heat of 80° to 85°, but recently potted plants, or those not having roots well established in the fresh compost, maintain at 90°.

Plants swelling off the fruit should have moderate atmospheric moisture, admitting a little air at the top of the house early in the morning, so as to allow of any superfluous moisture escaping before the sun's rays act powerfully upon the fruit. Any fruit it is desired to retard should be moved to a rather cool or shady house, affording abundance of air.

**FIGS.**—Planted out trees in Pig houses not infrequently grow rampantly, and consequently produce thin crops of fruit. In that case root pruning may be resorted to, and the roots be confined to a border from 3 to 4 feet in width. If the drainage be defective it will be necessary to lift the trees in the autumn as soon as the leaves commence falling and replant in fresh soil. Place in 9 to 12 inches of rough stones or brickbats for drainage, and over them a covering of

rather rough lime rubbish, using the finer parts for mixing with the compost in the proportion of a sixth to the bulk of turfy loam and a twentieth of crushed bones. In replanting, ram the soil well about the roots, for short-jointed fruitful wood cannot be so well secured by other means than by a solidified compost. The border should be 24 to 30 inches deep. Should the drainage be good it will only be necessary to confine the roots to the narrow border, removing some of the old soil from amongst them, and top-dressing with fresh loam with an admixture of lime rubbish and crushed bones as above stated. If the loam be light add a sixth of clayey marl; if heavy, a sixth of road scrapings. The proper time to operate in the manner indicated is as soon in late summer or autumn as the foliage gives indications of maturing.

**PEACHES AND NECTARINES.**—*Earliest Forced Trees.*—The leaves will soon be off, when loosen the trees from the trellis, clean the house, seeing to the needful repairs, and painting of the woodwork and trellis. The mulching and loose surface soil should be removed and fresh loam with a twelfth part of bone dust and a twentieth of wood ashes added, affording a moderate watering if the soil be dry. Whatever pruning is required should be done as soon as the house is put in order, but if the trees have been properly attended to very little work will require to be performed with the knife. Dress the trees with an insecticide. It is well to wash the whole of the trees by means of a brush with a soapy solution—say 4 ozs. softsoap to a gallon of water, adding a quart of strained tobacco juice, and if there be any scale a wineglassful of spirits of turpentine, keeping it well mixed by frequent stirring. In applying insecticides care should be taken to reach every part, and the brush should be used in such manner as not to injure or dislocate the buds. Trees cleaned and neatly secured to the trellis look far better than those left untrimmed until the latest period before starting.

**LATE HOUSES.**—The fruit is swelling well and requires very liberal supplies of water until the ripening is well advanced, when moderate supplies will be sufficient; enough, however, should be given to maintain the foliage in a healthy state. Trees that are making gross wood, and have a tendency to late growth, should be marked for lifting, an infallible remedy for indifferent setting and uncertainty of stoning. Any trees that do not ripen the wood well should be curtailed at the roots by taking out a trench, so as to detach the roots at about one-third the distance from the stem the trees cover on the trellis, doing it about the end of September or as early in October as the fruit is gathered.

#### PLANT HOUSES.

**Heliotropes.**—To have really good plants early in the spring in 5-inch pots for conservatory decoration cuttings should be inserted at once. They may be placed close together in 5 and 6-inch pots, and when rooted transferred into 3-inch, in which they can be wintered. The cuttings root freely if placed under handlights in a warm house and shaded from the sun. As soon as they are established in the small pots they should be hardened to greenhouse treatment. The shoots must be pinched from time to time, so that they may be dwarf and bushy by the early part of January, when they should be placed in their flowering pots and encouraged to grow. None of the plants intended for autumn and winter flowering should be pinched after this date. If practicable, place them where they can be protected at night in frames, but throw the lights off during the day. When there is a tendency for the temperature to fall at night below 45° the lights should be closed until morning.

**Cyclamens.**—Twelve to fifteen months are required in which to produce large well developed plants in 5 and 6-inch pots from seed. Seed should be sown at once in pans filled with moderately light soil, the seed to be just covered with fine soil and the pans placed in a temperature of 60° to 65°. The surface of the pans should be covered with a square of glass with damp moss laid over the surface. Under these conditions new seed will quickly germinate, and as soon as this takes place gradually harden the seedlings to bear full exposure to the light, and afterwards grow them on a shelf close to the glass.

**Primulas.**—Plants intended to flower in the early part of November will be strong and sturdy. These should have abundance of air, and the frames in which they are growing raised a few inches from the ground, so that the air will circulate freely amongst the plants and thus prevent the foliage drawing up weakly or damping. These should have a little artificial manure applied to the surface, for the pots should be full of roots by this time. This will assist the plants wonderfully and prevent them for a time throwing up flowers, which will be an advantage, for they quickly appear as soon as the pots become full of roots and it is useless to pick them off; the better practice is to prevent their appearance by keeping the plants growing. Successional plants will need careful watering, and the forwardest of them for early spring flowering may be placed at once into 5-inch pots and the remainder as soon as they are ready. The latest of all will not be ready for a month or five weeks, and some of the plants for even a longer period. These must have abundance of air day and night, for they are slightly drawn by shading rather heavier than usual during the hot bright weather we have experienced. By admitting abundance of light and air from this date the plants will be in thoroughly good condition by housing time.

**Scabious.**—Those intended for flowering indoors should be strong plants and ready for placing at once into 6-inch pots. They do well in good loam and one-seventh of manure. Plunge the pots outside in an open sunny position where they can remain until the approach of frost, when they must have the protection of cold frames or a light position in the greenhouse or any other structure. For flowering in spring seed

should be shown in a box or pan at once and stood in a cold frame. The young plants when large enough should be placed in 3-inch pots, in which they will pass the winter safely if given a position on a shelf close to the glass where the temperature at night will range about 40°.

*Pinks.*—A good batch of the common white garden variety and Mrs. Sinkins should be established in from 3 to 5-inch pots for forcing. For this purpose bushy plants should be lifted from the outside and potted. If these have not been previously prepared, strong cuttings of the former may be inserted thickly in sandy soil, and in a short time they will be well established if placed in a cold frame and kept well shaded.

## THE BEE-KEEPER.

### CYPRIAN AND OTHER FOREIGN BEES. CARNIOLIAN.

MR. G. REMMER wishes to know which of the breeds of bees are "best suited to the cottager." Taking everything into consideration, I place the Carniolian first on the list, not only for the cottager, but country gentlemen. They are hardy, have mild tempers, prolific, and good honey gatherers; therefore, will commend themselves to every person who keeps or examines them. Of all breeds they are the least affected by crossing. The pure ones are equal to the crossed for honey gathering. Moreover, they, as far as I have experienced, are not so subject to disease as other varieties are.

The most satisfactory way of securing these bees is to get them from some dealer. I have always placed myself in the hands of Messrs. G. Neighbour & Sons, and have advised others to that course, and I am glad to say there has never been the slightest cause for reflection. A Carniolian queen costs about 7s. 6d., and if a few cottagers in an isolated place would secure one and breed from, and secure pure fertilisation, it would pay them to supply queens and at the same time increase the pleasure and profit derived from bees. Introduce the queen to a good stock, with every precaution, so that she may not be killed. The safe method is to deprive the bees of the power of raising another queen from eggs or larvae, and to let the bees be queenless thirty hours. The safest method of increasing the stock is to allow it to swarm, or take the swarm artificially, and from the eighth to the tenth day after, not later, divide the bees and combs into nuclei. I frequently make twelve of these. The flying bees will be numerous on the one placed on the old site, and it must have fewest combs and brood, arranging and dividing the others, so as to equalise as much as possible each respective nucleus. Attention must be paid to these, so that none lacks food or the queen be lost, and these attended to properly make the best of stocks for next year, but be careful no surplus drone comb exists or is allowed to be built, or it may cause disappointment. Excess of drone comb causes bees to swarm prematurely, lessening the yield of honey as well as profit to the bee-keeper.

Unlike the Syrian bees, the Carniolian bees work well up to the day of swarming, but with this exception they surpass all other varieties when they have surplus bees to go to work. The Cyprians seem much of the same nature, and their crosses excel all others for honey gathering, but it is necessary to be careful to cross with the proper variety; and when this is done swarming is a rare thing with them while they have room. This last is the key to successful bee-husbandry. It is a mere sham to work with standard hives of nine or ten frames, and expect surplus honey in quantity from them. The best help and advice to give bee-keepers is to show them the proper hive to keep and work bees in. I have described the cheapest and best hive, which the merest type in handling tools can make at a cost of not more than 2s. 6d. each. This present week I have had numerous visitors from long distances, who, notwithstanding the fine season, have had no honey from the standard hives. I showed them the produce from my commodious and cheap hives, and they were all equally astonished, and the locality here is not a good one for bee-keeping.

I cannot speak for the future except from ten hives. I have queens for next year from two of them, two being set aside for that purpose. I lost one prime swarm totally and two others partially. I have taken 5 cwt. of super comb, while twenty-four stocks at the Heather, which, if all were put down, I should have from 8 to 10 cwt. more, and if favoured with a fortnight's fine weather between the 5th August and 31st, I have not the slightest hesitation in saying that these ten hives will give me a yield of considerably more than a ton of honey in one season.

The day before I wrote this an old man asked me to assist him taking off two supers from a hive swarmed three days before any of mine. Both his supers were soiled, one with brood and the other

by the bees daubing the combs all over, while the hive is under 40 lbs. in weight; the bees are supposed to be black ones. Not more than 100 yards distant from these bees is an apiary wrought upon my principle, whose bees have yielded even more than my own; but they are foreign bees crossed, and "cross" they are—following intruders into the house, and stinging them there. This spitefulness, however, I attribute to the way they are handled.

I hope these hints will assist Mr. Remmer in his purpose; but do not expect big things until big hives are adopted. Large as the yield of honey has been this year it is not equal to 1876. That year I had above 6 cwt. supers from six hives, irrespective of the Heather honey. The real honey season did not last more than two weeks this year; the drought became too great and shortened the season, then July brought showers, but we are satisfied.

There is one essential thing to know in bee-keeping, and that is to know the internal state of the hive, but if possible by experience, and not by meddling with them too much. In a future article I will give some information of aberrations in my apiary, some of them which even puzzled—A LANARKSHIRE BEE-KEEPER.

P.S.—To prevent swarming too often practise excising royal cells on the eighth day after the prime swarm issues, or divide into nuclei.

"R. C., Kent," page 80, and Mr. G. Remmer, page 103, would like to own stocks of Cyprians if the price of queens were within their means. I pen these lines to inform them, and others in the same fix, that there is a good time coming.

For years (as nearly all know) I have made queen-rearing and introducing a deep study. I have wanted daughters superior to their mothers, and after trying everyone's plan of queen-rearing I could not get a daughter better than her mother, though it was easy enough to get them worse. Cutting the queen cells out in chilly weather always resulted in a worthless queen. By careful observation, reflection, and experiment, I succeeded in getting improved daughters—queens that can fly well, even when laying 3000 eggs per day, and whose muscular powers enable them to run about like spiders, finding every empty cell, and depositing an egg in it. Queens that cannot move quickly soon have their ovaries overcharged with eggs, when the ignorant think they are large and fine, even when they are not laying a quarter of what they ought. To get such superior queens a very strong stock is required, and the cells must not be cut out or in any way meddled with to chill them; thus I could only get one queen instead of many. I began using my law of direct queen introduction to obtain serviceable queens, as by it I could calculate to the hour of hatching, and therefore what chilling they got was in their last stages. Not content with this, I followed up a clue, and now I can get the bees to keep them prisoners several days, and feed them in the meanwhile. Thus I get now fully matured virgin queens without any cell cutting, and each one is able—and will do, if she gets a chance—to fly.

So far, the above is important, but the queens require introducing to stocks or nuclei for mating, and all the authorities say virgin queens cannot be introduced without risk and trouble. Well, I can now remove a laying queen from any stock and enthrone a virgin one, with no further trouble than just turning up the quilt and dropping her in—it does not matter whether the queen has only just come from her cell or been with other bees a week—and I can enthrone a fertile queen at the same moment I remove a laying one, in the same way.

To test the value of the idea, I have sent quite a number of virgin queens by post to correspondents, and they have successfully introduced them, in accordance with my instructions. If the demand is great, I think the most superior bred virgin queens could be sold at 1s. each.

Superior virgin queens at a cheap rate would be an important factor in honey producing, especially comb honey—*e.g.*, queens rarely lead off a swarm in the season they are bred in; thus a stock could be brought up to swarming point with the old queen, and then replaced with a young one mated in a nucleus that had just begun laying. Such a stock would then not swarm, neither would it breed drones, nor would new hives be wanted for swarms.

Cyprians.—These have proved grand workers, and with proper handling are like tumbling flies about; in fact, nothing could be desired under the heading of tameness. I had no hybrids to begin the season, so cannot speak of them.

Syrians.—These require a little more care than Cyprians to handle; but still they are quite as manageable. My imported (1884) queen was superseded early in the season, so their tale is short. Hybrids crossed with pure native black drones have again proved the best over all others; in fact, I question if any cross will equal them for producing extracted honey, as it is always so clear and the bees so tame. I never saw them gather black honey, but beware of Syrians crossed with hybrid Italian drones. They



are perfect demons, and being very yellow they are dubbed by some dealers "pure Syrians."

**Carniolians.**—I had one imported queen whose bees proved equal in viciousness to any I have ever seen. Some of them showed traces of yellow blood, so I am satisfied they are not pure. Mr. Benton has sent me another one, tested, and which he says is the most valuable one he has ever had. Both the queen and bees are quite different to the other. Putting aside their temper they are grand workers and breeders, but I succeeded in keeping them from swarming; my plan seems to answer quite well, as I have never had a natural swarm since I practised it.

**Punic Bees.**—I had the misfortune to lose my imported queen, I fancy she led off a swarm; anyhow, I found she was missing at Whitsuntide and queen cells all sealed. These had piping queens on the 4th of June. I had counted four cells, but in reality there were ten. I left one in the old hive and enthroned seven in nuclei and other stocks. About the time of mating I found nearly all dead under the entrance. One I found "balled," which had just been mated, which I set at liberty, and which is all right now. I only got three queens laying; the one in the old hive began laying in seven days, and after filling every cell with brood ceased laying, and finally disappeared. I have now only two left, but hope to get another imported queen this year. They have proved remarkable bees, leaving the suspected swarm out. They never were fed after November, yet they produced the first drones, and had I not cut out the cells they would have cast, and it would have been the first swarm in the district. As honey getters they cannot be beaten, but their great point appears to be their extraordinary hardiness. The bees are the smallest I have seen, while the queens when not laying are no larger than our native bees, which makes it rather tedious to find them.

There has been no honey in this district since June; the heat having dried the sap out of everything.—A HALLAMSHIRE BEE-KEEPER.

#### TRADE CATALOGUES RECEIVED.

Sutton & Sons, Reading.—*Illustrated Catalogue of Bulbs.*

Webb & Sons, Wordsley, Stourbridge.—*Illustrated Catalogue of Bulbs.*

John Laing & Sons, Forest Hill, London, S.E.—*Catalogue of Bulbs, Fruit Trees, Roses, and Begonias.*

Charles Turner, The Royal Nurseries, Slough.—*List of Carnations, Picotees, and Pinks.*

Charles Toope & Co., Stepney Square, Stepney, London, E.—*Illustrated Catalogue of Heating Appliances.*

G. Shrewsbury, 122, Newgate Street, London, E.C.—*Illustrated List of Heating Appliances.*



All correspondence should be directed either to "THE EDITOR" or to "THE PUBLISHER." Letters addressed to Dr. Hogg or members of the staff often remain unopened unavoidably. We request that no one will write privately to any of our correspondents, as doing so subjects them to unjustifiable trouble and expense.

**Syringing Vines (F. J.).**—If the foliage of the Vines is only a "little dusty," you had perhaps better not syringe now the Grapes are nearly ripe. As they are Black Hamburgs they will probably be cut before the leaves change, and a heavy syringing can then be given with advantage.

**Small Nectarines (South London).**—The fruits are small because the crop is too heavy and the tree enfeebled in consequence. When a tree makes "no growth," and is at the same time "covered with fruit," those fruits cannot be otherwise than inferior, and the tree may be so exhausted that a year or more may be necessary for its recovery.

**Chrysanthemums (S. D.).**—The tops of these plants will strike freely now if inserted in sandy soil and kept close, moist, and shaded in a frame or under a handlight to prevent the leaves flagging. Three or four cuttings rooted in 3-inch pots, well managed, and shifted into 5-inch pots will flower in the autumn, these small plants often being very handy for decorative purposes.

**Marvel of Peru (Esher).**—We are glad your plants are giving so much satisfaction. Each of them will have produced a tuber, and after the plants are cut down by frost they may be dug up and the tubers dried and stored like Dahlias or Begonias. They will survive the winter in well-drained soil if a thick layer of ashes be spread on the surface, and so will Dahlias.

**Nectarines Shrivelling (T. A.).**—We can only account for the shrivelling of the fruit by excessive evaporation, the powerful sun extracting the moisture from them more quickly than it was supplied by the roots. We have known light shade, such as that afforded by hexagon netting, useful

when the sun was extremely hot and inferior glass employed in glazing the roof.

**Outdoor Vine (T. Marks).**—You have done quite right in allowing some of the young growths to extend from the base and training them between the main rods. As there is no fruit on these you had better cut back the laterals, so as to expose the young canes and the leaves as fully as possible, and they will mature the better and to a greater length. These canes, being strong, will bear fruit next year.

**Laycoring Carnations (J. Jarvis).**—The sooner this work is completed the finer will be the plants for flowering next year. Those layered early will not pipe for flowering as a rule; a few of them may, and the growths would have done so if they had not been pegged into the ground. There is not much fear of doing this work too soon, and much more danger in deferring it too late.

**Coleworts (Groom and Gardener).**—It is certainly not too late for planting these, and many gardeners would be glad to have such a fine lot of young plants as those you describe. Take no notice of your adviser, but at once put them out a foot apart in rows 18 inches asunder in any ground you may have at liberty, and you will find them very serviceable in winter and early spring. We have just planted several hundreds without digging the ground, but it was not very hard.

**Tomatoes (Doubtful).**—We will remove your doubts by informing you that flower trusses that are produced after this season of the year will be too late to be of any service, and therefore you cannot do better than top the plants in the open air and suppress all further growths that may appear; the fruit already set will then have a better chance of swelling and ripening. If some of the large leaves shade the clusters heavily either draw the foliage aside or cut some of it off.

**Coleuses (Amateur).**—Under the circumstances you had better not attempt to preserve the old plants, as you clearly have not room for them, and young plants will produce finer foliage and be more suitable for your purpose next year. Cuttings strike freely now in close warm frames, shading to keep the leaves fresh. You may insert one in the centre of a 3-inch pot, or three or four round the sides of a larger, and in these pots the plants may be wintered on a shelf in a warm house, a dozen or two not taking up much room, and if you want more you can raise them in the spring.

**Palms and Cycads (C. R.).**—These are totally distinct, and a Cycas cannot properly be exhibited in a class for Palms, nor a Palm in a class for Cycads. Occasionally we have seen a class for "Palms and Cycads," and both kinds can then be associated without fear of disqualification. There is no relation whatever between the two genera—indeed, botanically speaking, Cycas revoluta is more nearly related to a Fir tree than it is to a Palm. If you have cited the class accurately you were properly disqualified.

**Marechal Niel Rose House (S. S.).**—1, You are quite right in respect of the lantern ventilation, which should be continuous, and open the whole length of the house; similar remarks apply to the side ventilation. 2, Three shoots to a plant would be sufficient, as it will allow of young growths being trained in from the base to take the place of the old rods after they become worn out. You may safely train two or more shoots to a wire, which will give a large number of blooms, besides affording choice at pruning, cutting out the old and weak growths, leaving the stronger and well ripened so as to insure large and well formed blooms. The blooms are very fine at Burgbley.

**Strawberries (F. O.).**—Unless the rooted runners are very strong now and the soil very good you cannot expect a satisfactory crop of Strawberries next year; but very strong plants inserted now and well attended to afterwards will bear fine fruit next season. This is what forced Strawberries do, and similarly strong plants may be had for planting out if equal care is taken in producing them. As a rule, Strawberry runners are not strong this year, and if yours are weak you had better not rely on them. If some of the crowns are thinned from the old plants, and the bed well soaked with liquid manure, they will perhaps bear a better crop next year than they have borne this season, and if you pick the flower trusses from the young plants if weak in the spring they ought to be in the best condition for bearing the following year.

**Cœlogyne corrugata (Alpha).**—This Cœlogyne will do very well during the period of rest in the Odontoglossum house where the night temperature ranges about 45°. It will do in this structure with these plants the whole year round, but is benefited during the season of growth by slightly warmer conditions. It would do admirably during the growing season with Cattleyas and Lælias where the night temperature is kept at from 60° to 65°. If you cannot give this temperature you need not despair of cultivating it successfully in a cool house during the summer without the aid of artificial heat, as long as you maintain a night temperature of 45° from October until May. This species does well in a pot or pan if potted in a compost of fibry peat with lumps of charcoal freely intermixed. Liberal drainage must be provided, and the pot or pan used should be filled at the least one-third full.

**Lilium neilgherrense (Idem).**—This has white sweet-scented flowers, which are funnel-shaped, and from one to three are produced on each stem, but generally only one. The flowers are larger than those of *L. longiflorum*. *L. neilgherrense* is synonymous with *L. tubiflorum* and, perhaps, *L. Wallichianum*. The stems attain a height of 3 or 4 feet, but Mr. McIntosh has grown it 7 feet high planted in a Rhododendron bed, the plant being one grand flower. This Lily does not require heat in its culture, and will do very well in a cool greenhouse or even planted outside. It will also bear gentle forcing.

**Gunnera scabra (T. A. Todd).**—This plant is hardy in some positions, especially in the southern parts of the country. It will grow vigorously in a damp warm situation where it can be sheltered from rough cutting winds. It is a noble plant, and has a very picturesque appearance in a position where it does well on the lawn or in the park. Some care is needed to protect its creeping rhizomes during severe weather in winter. For this purpose dry leaves or bracken are about the best materials that can be used. The only method of propagation known by us is by division. Portions taken off should be potted and established in a cold frame, and planted out during genial weather in spring in good fertile loam that has been previously well enriched with manure. When once established out-

side the only treatment that is needed is protection during the winter in the form of such mulchings as are given to Globe Artichokes.

**Rudbeckias and Helianthus (A. M.).**—An authority on these flowers says: "Both the specimens sent by you are forms of *Helianthus rigidus*, known also in the trade as *Harpalum rigidum* and *Helianthus atrorubens*. There if no such plant as *H. japonicus*—indeed, there is no *Helianthus* found either in China or Japan, and how it has come to be sent out as such I cannot find out. This *H. rigidus* is a variable plant both in the wild habitats and under cultivation, varying both in height (from 1½ to 6 feet), size and shape of leaves, and flowers. *Rudbeckia* is quite a distinct genus, and may be readily recognised from *Helianthus* by its involucre, flower heads, and habit. *Rudbeckia amplexicaulis* is well worth growing for its curious conical disk and large ray florets; but it is only an annual, while the above is a perennial."

**Alpine Strawberries (W. S.).**—They require the same treatment as to manuring the ground and general culture as Strawberries generally. They are best raised from seed, which if sown in a pan in any light earth in March, and placed in a mild bottom heat, will come up in a few days, and should then be removed to a cold frame to harden off. If due attention be paid to watering the plants will grow rapidly, and when of sufficient size to transplant they should be planted out in beds, allowing 1 foot between the plants every way. Seed sown in spring usually furnishes plants for late autumn bearing, and the runners of the previous year planted in March or April bear abundantly early in autumn. The ground in which they grow should be well watered in hot dry weather, otherwise they cease bearing and become weak. It must be kept moist in order that they may bear constantly.

**Red Spider (A. G. B.).**—Gather your fruit as soon as possible after it is ripe, then if you have a large tub or cistern, dissolve 5 or 6 lbs. of soft soap in about 10 gallons of water in which 3 lbs. of quassia chips have been previously boiled for ten minutes, then add as much water to this as will enable you to dip your trees in so that the whole of the wood and leaves may become well wetted with this hitter water. If this is repeated two or three times at intervals you will soon get rid of the pest. For the future keep your trees well syringed with a decoction of similar strength whenever the slightest signs of the enemy appear. Syringe your walls with the same mixture as that recommended above, add to it 5 lbs. of sulphur. After this the walls should be well coated over with a thick grouting made of lime cement, using the grounds of the quassia water to mix it with. This grouting should be well worked into the nail-holes, &c., in the wall by daubing the brush several times against it.

**Cheilanthes odora (L. M. E.).**—This Fern is rather difficult to cultivate. Half fill the pots with corks, and have some sandy turfy peat chopped fine, pieces of sandstone broken to the size of a Walnut, and some sweet hazel or yellow loam. Mix them together in the proportion of two parts of the sandstone to one of the peat and loam, and if the very fine particles of the sandstone he sifted out all the better. In this mixture pot the plants rather high in the centre of the pots, and around them place pieces of sandstone, or rather plant so that they may appear growing from between stones, the pot being covered with these, and the loam and peat in the interstices. Give a good watering, and place in an airy and light situation in the greenhouse. This Fern will do best kept near the glass, and near the point of admission of air. If shaded from very bright sun until it becomes established all the better, and, though it will not grow in much shade, it is more free-growing when partially screened from the powerful mid-day sun. It is very impatient of stagnant moisture, and should never be very wet nor dust dry.

**Names of Plants.**—We only undertake to name species of plants, not varieties that have originated from seed and termed florists' flowers. Flowering specimens are necessary of flowering plants, and Fern fronds should bear spores. Specimens should arrive in a fresh state in firm boxes. Slightly damp moss or soft green leaves form the best packing, dry cotton wool the worst. Not more than six specimens can be named at once. (E. G.).—1, *Olearia Haasti*; 2, *Veronica Traversi*; 3, *Rhus cotinus*; 4, *Jasminum revolutum*. (B. Paget).—1, *Asplenium bulbiferum*; 2, *A. flaccidum*; 3, *Nephrolepis tuberosa*; 4, *Pteris umbrosa*; 5, *Gymnogramma chrysophylla*; 6, *Adiantum decorum*. (O. Egan).—1, *Gaillardia picta*; 2, *Achillea Ptarmica flore-pleno*; 3, *Helenium pumilum*; 4, *Nepeta teucrioides*.

COVENT GARDEN MARKET.—AUGUST 24TH.

BUSINESS steady down, with good supplies of all classes of fruit.

FRUIT.

	d.	s.	d.	s.	d.	s.	d.
Apples, ½ sieve .. ..	1	6	to	3	6		
Nova Scotia and							
Canada barrel	0	0	0	0	0		
Cherries, ½ sieve .. ..	0	0	0	0	0		
Cobs, 100 lbs. .. ..	0	0	0	0	0		
Figs, dozen .. ..	1	6	2	0	0		
Grapes, per lb. .. ..	0	6	2	6	0		
Lemons, case .. ..	10	0	15	0	0		
Melon, each .. ..	2	0	3	0	0		
Oranges, per 100 .. ..	6	0	to	12	0		
Peaches, dozen .. ..	2	0	6	0	0		
Pears, dozen .. ..	1	0	1	6	0		
Pine Apples, English,							
per lb. .. ..	1	6	0	0	0		
Plums, ½ sieve .. ..	3	0	4	6	0		
St. Michael Pines, each	3	0	5	0	0		
Strawberries, per lb. ..	0	0	0	0	0		

VEGETABLES.

	s.	d.	s.	d.	s.	d.	s.	d.
Artichokes, dozen .. ..	1	0	to	2	0			
Asparagus, bundle .. ..	0	0	0	0	0			
Beane, Kidney, per lb. ..	0	3	0	0	0			
Beet, Red, dozen .. ..	1	0	2	0	0			
Broccoli, bundle .. ..	0	0	0	0	0			
Brussels Sprouts, ½ sieve	0	0	0	0	0			
Cabbage, dozen .. ..	1	6	0	0	0			
Capsicums, per 100 .. ..	1	6	2	0	0			
Carrots, bunch .. ..	0	4	0	0	0			
Cauliflowers, dozen .. ..	3	0	4	0	0			
Celery, bundle .. ..	1	6	2	0	0			
Coleworts, doz. bunches	2	0	4	0	0			
Cucumbers, each .. ..	0	4	0	6	0			
Endive, dozen .. ..	1	0	2	0	0			
Herbs, bunch .. ..	0	2	0	0	0			
Leeks, bunch .. ..	0	3	0	4	0			
Lettuce, dozen .. ..	0	9	to	0	0			
Mushrooms, punnet .. ..	0	6	1	0	0			
Mustard and Cress, punt.	0	2	0	6	0			
Onions, bunch .. ..	0	3	0	6	0			
Parsley, dozen bunches	2	0	3	0	0			
Parsnips, dozen .. ..	1	0	0	0	0			
Potatoes, per cwt. .. ..	4	0	5	0	0			
Kidney, per cwt. .. ..	4	0	0	0	0			
Rhubarb, bundle .. ..	0	2	0	0	0			
Salsafy, bundle .. ..	1	0	1	6	0			
Scorzoneria, bundle .. ..	1	6	0	0	0			
Seakale, basket .. ..	0	0	0	0	0			
Shallots, per lb. .. ..	0	3	0	0	0			
Spinach, bushel .. ..	3	0	4	0	0			
Tomatoes, per lb. .. ..	0	4	0	6	0			
Turnips, bunch .. ..	0	4	0	6	0			

PLANTS IN POTS.

	s.	d.	s.	d.		s.	d.	s.	d.		
Aralia Sieboldi, dozen ..	6	0	to	12	0	Fuchsia, dozen .. ..	3	0	to	9	0
Arbor vitæ (golden) dozen	6	0	9	0	0	Geranium (Ivy), dozen ..	3	0	6	0	0
(common), dozen .. ..	0	0	0	0	0	Tricolor, dozen .. ..	3	0	6	0	0
Asters, dozen pots .. ..	3	0	6	0	0	Gladiolus .. ..	4	0	6	0	0
Azalea, dozen .. ..	0	0	0	0	0	Hydrangea, dozen .. ..	9	0	12	0	0
Begonias, dozen .. ..	4	0	9	0	0	Lilies Valley, dozen .. ..	0	0	0	0	0
Calceolaria, dozen .. ..	3	6	8	0	0	Lilium lancifolium, doz.	12	0	18	0	0
Cineraria, dozen .. ..	0	0	0	0	0	longiflorum, doz. ..	0	0	0	0	0
Creeping Jenny, dozen ..	0	0	0	0	0	Lobelia, dozen .. ..	0	0	0	0	0
Dracæna terminalis, doz.	30	0	60	0	0	Marguerite Daisy, dozen	6	0	12	0	0
viridis, dozen .. ..	12	0	24	0	0	Mignonette, dozen .. ..	3	0	6	0	0
Erica, various, dozen .. ..	0	0	0	0	0	Musk, dozen .. ..	2	0	4	0	0
Euonymus, in var., dozen	6	0	18	0	0	Myrtles, dozen .. ..	6	0	12	0	0
Evergreens, in var., dozen	6	0	24	0	0	Palms, in var., each ..	2	6	21	0	0
Ferns, in variety, dozen	4	0	18	0	0	Pelargoniums, dozen ..	6	0	12	0	0
Ficus elastica, each ..	1	6	7	0	0	scarlet, doz. .. ..	3	0	9	0	0
Foliage Plants, var., each	2	0	10	0	0	Spirea, dozen .. ..	0	0	0	0	0

CUT FLOWERS.

	s.	d.	s.	d.		s.	d.	s.	d.		
Abutilons, 12 bunches ..	2	0	to	4	0	Lilies, White, 12 bunches	0	0	to	0	0
Anemones, 12 bunches ..	0	0	0	0	0	Orange, 12 bunches	0	0	0	0	0
Arm Lilies, 12 blooms ..	3	0	6	0	0	Lily of Valley, 12 spray?	0	0	0	0	0
Asters, 12 bunches .. ..	3	0	6	0	0	" 12 bunches .. ..	0	0	0	0	0
French, bunch .. ..	1	6	2	0	0	Marguerites, 12 bunches	2	0	6	0	0
Azalea, 12 sprays .. ..	0	0	0	0	0	Mignonette, 12 bunches	1	0	3	0	0
Bluebells, 12 bunches ..	0	0	0	0	0	Myosotis, 12 bunches ..	2	0	3	0	0
Bouvardias, bunch .. ..	0	6	1	0	0	Narciss, 12 bunches ..	0	0	0	0	0
Camellias, blooms .. ..	0	0	0	0	0	White, English, bch.	0	0	0	0	0
Carnations, 12 blooms ..	1	0	2	0	0	Pansies, 12 bunches ..	0	0	0	0	0
" 12 bunches .. ..	4	0	6	0	0	Peas, Sweet, 12 bunches..	3	0	6	0	0
Cornflower, 12 bunches ..	1	6	3	0	0	Pelargoniums, 12 trusses	0	9	1	0	0
Dahlia, 12 bunches .. ..	3	0	6	0	0	scarlet, 12 trusses	0	3	0	6	0
Daisies, 12 bunches .. ..	2	0	4	0	0	Pinks, White, 12 bunches	0	0	0	0	0
Eucharis, dozen .. ..	4	0	6	0	0	various, 12 bunch	2	0	4	0	0
Gardenias, 12 blooms ..	2	0	5	0	0	Pæony, 12 bunches .. ..	0	0	0	0	0
Gladiolus, 12 sprays ..	1	0	1	6	0	Poinsettia, 12 blooms ..	0	0	0	0	0
Hyacinths, Roman, 12						Primula (single), bunch..	0	0	0	0	0
sprays .. ..	0	0	0	0	0	(double), bunch .. ..	0	9	1	0	0
Iris, 12 bunches .. ..	0	0	0	0	0	Polyanthus, 12 bunches..	0	0	0	0	0
Lspageria, white, 12						Ranunculus, 12 bunches	0	0	0	0	0
blooms .. ..	0	0	0	0	0	Reses, 12 bunches .. ..	2	0	6	0	0
Lspageria, coloured, 12						(indoor), dozen .. ..	0	9	1	0	0
blooms .. ..	1	0	1	6	0	Tea, dozen .. ..	1	6	3	0	0
Lilac (white), French,						red dozen .. ..	0	0	0	0	0
bunch .. ..	0	0	0	0	0	de Mois, 12 bunches	0	0	0	0	0
Lilium longiflorum, 12						Stephanotis, 12 sprays ..	2	6	4	0	0
blooms .. ..	2	0	4	0	0	Tropaolum, 12 bunches	0	0	0	0	0
Lilium lancifolium, 12						Tuberoses, 12 blooms ..	0	6	1	0	0
blooms .. ..	1	6	3	0	0	Tulips, dozen blooms ..	0	0	0	0	0



GREEN CROPS.

WITH pasture parched and browned by heat and drought the very mention of green crops has a refreshing yet tantalising effect upon the mind. Who has green crops now, fresh, succulent, vigorous? Such crops are indeed few and far between, and the fortunate owners of them can command from £1 to £3 per acre for those of moderate vigour from eager flockmasters who are in difficulties about food for sheep. Really vigorous crops of Italian Rye Grass and Lucerne command exceptionally high rates just now, and they are always profitable, for even when not required in a green state they can be turned to account for hay or silage. Italian Rye Grass and sewage farming answer so admirably that some farmers regard the connection as inseparable. There can, however, be no reason why heavy successional crops of this valuable strong-growing forage plant should not be had even in such a season as this in any soil, if only sewage or water is applied to it by means of a water cart and spreader. When sewage cannot be had 1 cwt. of nitrate of soda per acre applied immediately after each crop is mown, and well dissolved and washed in by passing the water cart over it a few times, insures growth after growth of surprising vigour and quickness. By this means we can command a crop, without it we are at the mercy of the weather. How absurd is it to hear good people loud in complaining of our fickle climate, of the baneful effects of a long drought, of a serious falling off in the yield of

milk owing to a scarcity of green food for their cows, yet failing to avail themselves of a means so simple and sure. About the cost? Of course, we take that fully into account, and a little consideration will show that the outlay for manure, water cart, and due provision for water storage is both wise and profitable.

We desire also to call especial attention to the value of Lucerne, and we do so with feelings of regret and surprise that its value as a forage plant is so little recognised. Here is a plant of most easy culture, a hardy perennial, quickly established, and rooting so deeply down into the soil as to be literally drought proof, continuing to yield growth after growth throughout such a hot dry summer as this is, and yet fields of it are few and far between. Why this useful and invaluable plant is so much neglected passes our comprehension. We have known it intimately for upwards of thirty years, and yet even now farmers generally cannot be aware of its real value as green or dry forage for all the live stock of a farm. It should always be sown in drills so as to be kept clean by a horse hoe, and be heavily manured every spring. So kept clean and fed it may be left down from six to twelve years. The first piece we remember was grown specially for horses, and so valuable was it in the opinion of a certain noble lord that the soil between the rows was regularly broken up by digging forks every winter. It was mown four or five times between spring and autumn, and the gross bulk per acre must have been many tons. Since then we have seen it growing both in rows and sown broadcast, and have invariably found it answer best in rows, the broadcast plots becoming so foul with weeds as to be comparatively worthless after the third year. For sheep folding it answers admirably, being as sound and wholesome for them as Sainfoin, and they can be taken upon it again and again for a full bite, when the other pastures are brown and bare. It is usually sown in early spring, and then affords one or two crops before growth ceases; but there can be no reason why it should not be sown as late as July or August if due care be taken to have the tender growth eaten off early in October.

A calcareous subsoil is considered best for it, but so far as our experience goes we have reason to suppose it will answer in most soils. Far better is it to devote a field or two to so useful a crop as this than to waste land upon such a worthless plant as Prickly Comfrey. Let it not be thought, however, that these remarks are meant solely for the speculative or fanciful amateur. It is to the practical farmer, keen to turn every foot of his land to account, that we say Lucerne is a plant that should have a leading place among forage crops, and take rank with the best of them. We have shown cause why it should do so, and are very sure that no one will have reason to regret following our advice in this matter. It is as green food in summer that we value it most especially in a time of drought, but there can be no doubt that as hay it is highly nutritious for horses.

(To be continued.)

#### WORK ON THE HOME FARM.

That much of the plant of young layers has been destroyed by the drought there can be no doubt, and much Clover will have to be sown immediately after harvest to make good such losses. We have even heard inquiry made for Sainfoin seed for immediate sowing. Our own young Sainfoin has withstood the effects of the drought very well, but we are anxious about some permanent pasture sown in spring with corn. The plants came up well enough, but it has been a difficult matter to see any of them for the last month on the heavy land, and where the surface has contracted and cracked much many plants must be lost. The clearance of corn from the land will be followed as quickly as possible by the preparation for sowing green crops for late autumn and early spring use. *Trifolium incarnatum* is already sown. Where this

has not been done let not a day be lost in doing it, for late sown *Trifolium* is generally a failure. It is because we have had such failures in our own practice more than once that we warn our readers to sow quickly or not at all. For *Trifolium* to pass through winter in safety there must be a strong sturdy plant covering the surface in October. If the plant is so small as to be seen with difficulty, the crop may be considered a failure. Select a clean stubble, which if left long should be cleared by harrowing, then sow the seed broadcast, and pass the harrows over again once or twice. If the surface is so coarse as not to cover the seed, well crush it with a light Barley roller, and finish with another turn of the harrows. Where enough rain has fallen to moisten the surface to a depth of a few inches stubble Turnips should be sown extensively. No doubt the roots from such sowings will be small, but they will prove very useful for sheep and lambs in early spring before the Rye is ready. On one of our farms the Swede plant is numerous enough, but is so backward that the lambs will be turned upon it to consume what growth there is at once, and the land will be ploughed for early Wheat sowings. Other land, which was prepared for early white Turnips, could not be sown at all, and will also be turned to account for Wheat. Sowings of Rape and Mustard made now will probably afford a useful supply of green food late in autumn for the flock. Any such crops will enable us to save the grass for the lambing. Lamb tups should be procured not later than the first week in September. They are low in price this season, excellent animals being sold for £2 apiece.

#### THE HESSIAN FLY (*CECIDOMYIA DESTRUCTOR*).

THE British farmer has been talking of the Hessian fly ever since the period of the American Revolution in the days of good King George, and it is hard upon him that the insect should actually appear on these shores now, at a time when the agricultural interest is so depressed, though it is Queen Victoria's Jubilee year. But it was observed to occur in more than one locality last year, though some entomologists had a doubt whether another species had not been mistaken for this notable fly; for in the same group of insects are several, also foes of the cereal crops, and in appearance, or even in habits, not unlike the much-dreaded pest. We may accept it, however, as an incontrovertible fact, that up to the year 1886 none but straggling specimens occurred in England (if any), though the insect has been known as one of the most destructive amongst the "blights of the Wheat" for just a century. It should be stated, perhaps, that the appellation of the "Hessian fly" arose from a notion that the German mercenaries brought the plague into the United States, but this was proved to have been impossible. From 1786 onward, however, the Hessian fly has caused enormous destruction of corn in the American Continent, and extended itself over a great part of those regions where grain is an important crop. It has been conjectured that the primitive habitat of the fly is on the borders of Europe and Asia—*i. e.*, about the shores of the Mediterranean, but this appears to me very unlikely, seeing that it was first found to be doing mischief in America, and I would rather assign it to that country. In Europe there is no record of its occurrence until 1834, in Minorca, or possibly 1833, in Hungary; it is reported from France, Austria, and other countries now, the South of Russia being the last where it has caused alarm, but in the Old World as yet the injury done is trifling compared with the New, and all the researches of the American scientists and the persevering efforts of growers have failed to put an effectual check on its yearly propagation and ravages.

Having thus touched briefly upon its general history I proceed to describe the structure and habits of this fly, called in science, very aptly, *Cecidomyia destructor*, and we have the advantage of Mr. Meade's examination of British-bred specimens, as recorded in the "Entomologist." The perfect insect has the head and eyes black and hairy, the antennæ are rather long and brownish, the proboscis small and pink, the thorax black, with two red streaks running from the neck to the base of the wings, the abdomen reddish brown, with regular black spots, which coalesce in some specimens, the legs pink, sprinkled with blackish hairs, the wings, transparent as usual, are also hairy. In the male flies the wings are longer and appear of a reddish tinge, and the legs are paler, but the females, on the whole, are the larger, and they seem to be more abundant than the males. The number of eggs laid by each female has been variously stated between ten and fifty; probably the small estimate is nearest to the average, if the size of the egg is correctly reported. Like the larva of all flies, the maggot of the Hessian fly is legless, but it has just below the head a curious process or appendage, which the American observers call the "breastbone." It is found in several species of *Cecidomyia*; the use is not known positively, but no doubt this in some way aids the larva in acquiring its food, the mouth organs being somewhat feeble. This maggot is oval and glossy, with the head not very discernible; its skin dotted over by a number of tiny tubercles, in colour white or greyish. To the chrysalis or pupa the name of flax-seed is familiarly applied, from its likeness to that object. This, however, is really the cast-off integument of the maggot, forming a puparium, in which the true pupa lies to await its transformation to a fly. This puparium is brown, spindle-shaped, flattened, and each end is bluntly pointed. This pupa stage is of special importance, for the puparia are hidden in the stalks of the cereal, solitary often, sometimes two or three together, and it is by this agency the species travel from one district or country to another, as the flies themselves do not take long journeys.

In most places where the Hessian fly has been under notice two



broods occur yearly, and the economy of the species is as follows, it being premised that the second brood is that of which we know more from the obvious results of its attacks. The autumn flies emerge in August or September from the pupæ, which are almost invariably found above the second joint of the straw from below, and seek out the young Wheat or Barley (it is one of these the fly chiefly attacks); placing eggs on the sheath or young leaves, the larvæ work their way gradually into the plants, which die off about the time the insects turn to pupæ, in which state the winter is passed. Emerging about April, the next brood of flies finds the crop in an advanced stage of growth, and the larvæ produced in May and feed in, or between, the sheath and the stem. Here they lie in small parties of six or eight (fig. 22), and the stem, when they are increasing in size, bends at an angle and not unfrequently breaks at the point where the attack has been made, the ear if formed containing but a few dwarfed grains. By the time the corn is cut, or soon after, the insect has completed its larval existence and is ready to journey elsewhere in its form of "flax-seed" during the autumn, for it does not seem probable that the pupæ or "flax-seed" which are produced from the spring Wheat scatter to any distance.

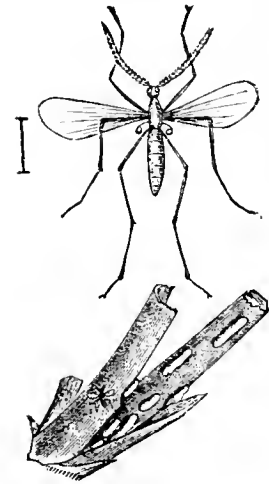

Fig. 22.

As full particulars concerning last year's visitation of the Hessian fly have appeared in this and many other journals, it is only needful to say that the first specimens noted in 1886 were forwarded to Miss Ormerod from Barley fields near Hertford. Subsequent reports of its occurrence came from three other places in Hertfordshire, from Romford, Essex, and Luton, Bedfordshire. Later in the season the fly was found north of the Tweed near Inverness, and near Crieff, localities where its appearance is certainly singular. Though no complaints that I am aware of were made with reference to the spring brood on the early corn, it must have bred to some extent, for early in the summer of this year Wheat and Barley were found to be infected in several of the places which had produced the insect last year, and by degrees intelligence has come in of a number of fresh attacks, the districts being often wide apart, and as before both in England and Scotland. Mostly they are not spread over a wide area, I believe, except in South Lincolnshire, which has suffered considerably. It is not supposable that all these localities have been infected by the progeny of the flies noticed last year, we must conclude there have been new importations of the enemy. "Where has the attack come from?" asks Miss Ormerod, and Echo answers, "Where!" It is mysterious, but there can be no dispute that in the "flax-seed" or pupa state the insect must have come to us from the Continent or from America. Probability points to the former. That we should have escaped hitherto may be deemed an encouraging circumstance for the future, as we may hope the climate of Britain is not particularly favourable for this fly, or it would have got a lodgment before, since the pupæ must have been brought over by accident. It is considered as proved they do not come in grain; they must therefore travel in the straw, either when that article is imported as cargo, or when it is used for packing. An examination of what is called "corn rubbish" has yielded "flax-seeds," so that this medium may convey the insect from one locality to another in Britain. As yet, however, I cannot say it is clearly made out how pupæ contained in foreign straw can be distributed over our corn fields. One way that has been suggested is this—To London, and to some other towns, quantities of goods are sent from various countries of Europe packed in straw, the surplus of this is sold off by wholesale houses, and next reaches stables, where it is finally converted into manure, and then is made use of by farmers or market gardeners. If so, we ought to have the Hessian fly about Kent, especially near the Thames and the Medway, for we receive much London manure. We are also in frequent communication with the Continent, but I have no report of it at present. Possibly the Kentish soil does not produce a growth of Wheat and Barley agreeable to the insect, owing to its being generally chalky, and it may thrive best where the plants are on clayey or loamy soil. And it has been surmised that the Hessian fly is a lover of moisture; if such be the case, then we may presume that had 1887 been a wet instead of a dry summer, we should have found a greater abundance of the insect.

However matters may be abroad, our peculiar circumstances indicate that, in this island, we ought not to have much difficulty with the foe. Mr. Palmer, who has had a good deal to do with the Hessian fly on his Hertfordshire farms, advocates high cutting, so that the insect may be left in the stubble; this is afterwards to be collected and burnt. In theory this is excellent, but in practice the plan is inconvenient to carry out. Others have advised burning off the stubble under any circumstances where a crop is affected, because it is sure to contain some "flax-seed." The Americans are understood to disapprove of this, because in this way not only is the fly killed, but sundry parasitic enemies that prey upon it are destroyed too. Late sowing is one of the most effective means of stamping out a brood, the autumn flies having then, on emergence, no young plants to deposit eggs upon, and die off harmless. Ploughing over infected fields directly after the crop has been removed will kill some pupæ, and the siftings of threshing or dressing machines should be burnt, as recently advised by the Govern-

ment Commissioners. Certain varieties of Wheat are hard-stemmed. These are seldom attacked by the fly, and in any case, whatever interferes with the healthy growth of the crop, subjects it to the danger of being infested. Another important point is to attend to the rotation of crops. When cereals have been visited by the insect, the next year leguminous or root crops should be grown on the fields, if possible. Where the occurrence of the pest amongst young Wheat is known or suspected, it should be dressed in spring with lime, soot, sulphur, or even salt, applied when the plants are moistened by dew or rain.—ENTOMOLOGIST.

To the above interesting account of this destructive enemy to important crops we append illustrations, representing its various forms, with

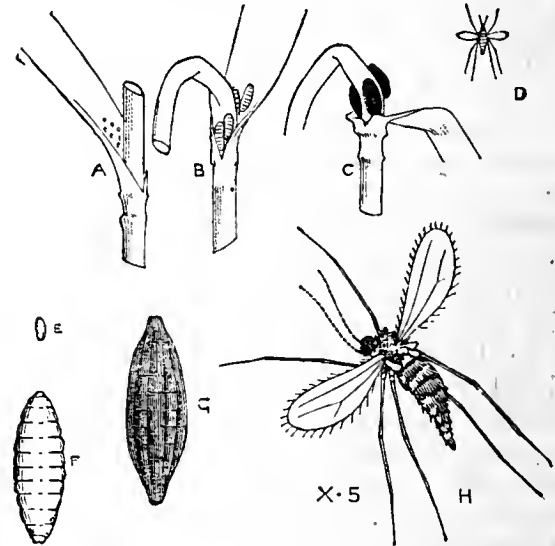

Fig. 23.

explanatory notes, for which we are indebted to Messrs. E. Webb and Sons, Wordsley, Stourbridge, in whose farm seed catalogue the figures appear with a history of the enemy, and suggested methods for preventing its attacks.

In the illustration (fig. 23) we have shown natural size at A, B, C, and D, the eggs, maggots, chrysalids, and perfect insect belonging to the Hessian fly. Underneath at E, F, G, and H, the same stages of growth are shown enlarged five diameters. The eggs are shown at A, at the base of a Wheat leaf; at B the maggots, often six or eight in number, have emerged from the eggs, and are shown as grown to fully mature examples; at C the maggots have fixed themselves close to the stem, and after a lapse of five or six weeks have taken on the brown chrysalis or 'flax-seed' condition; at D the perfect Hessian fly is shown as it emerges from the chrysalis—i.e., when the latter is about ten days old. The mischief is caused by the maggots, which fix themselves on the young corn, or when the corn is older, near the three lowest joints of the stem or close to the root, and there suck the juices of the plant. The effect of this injury is that young plants are killed, and the stems of older plants are so greatly weakened that the ears only produce a few grains at most, and the corn stem itself commonly bends abruptly down to the ground, either from the root or from one of the joints a little above it."

METEOROLOGICAL OBSERVATIONS.

CAMDEN SQUARE, LONDON.

Lat. 51° 32' 40" N.; Long. 0° 8' 0" W.; Altitude, 111 feet.

DATE.	9 A.M.					IN THE DAY.				Rain	
	Baromet. at 32° and Sea Level.	Hygrometer.		Direction of Wind.	Temp. of soil at 1 foot.	Shade Temperature.		Radiation Temperature.			
		Dry.	Wet.			Max.	Min.	In sun.	On grass		
1887.											
August.											
Sunday .....	14	29.997	57.6	51.5	N.W.	64.7	68.0	52.0	118.2	51.7	—
Monday .....	15	30.053	57.7	51.9	N.E.	64.3	71.2	42.5	98.4	40.3	—
Tuesday .....	16	29.770	59.6	55.4	N.E.	63.3	65.7	53.2	80.4	52.0	0.609
Wednesday .....	17	29.789	56.7	55.6	E.	62.2	66.2	53.2	92.6	53.0	1.437
Thursday .....	18	29.877	59.2	54.7	N.	60.6	66.4	51.6	105.7	50.6	—
Friday .....	19	29.952	57.5	53.9	N.W.	60.2	67.8	46.8	114.6	45.0	—
Saturday .....	20	29.881	54.6	52.4	N.E.	59.8	66.4	51.4	105.8	50.2	0.062
		29.908	57.6	53.6		62.2	67.4	50.1	102.2	49.0	2.108

REMARKS.

14th.—Fine, bright, and cool; cold at night.  
 15th.—Bright early, but cool; fog, unusually dense for the time of year, from 9.30 to 10.30 A.M., and hazy after—a regular autumn morning; fine afternoon.  
 16th.—Dull all day with spots of rain.  
 17th.—Heavy rain from midnight to 1 A.M., and from 4.30 to 6 A.M.; dull showery morning; fine afternoon, with some sunshine; thunder commenced about 5.30 P.M., and from 6.30 to 9 an exceptionally severe thunderstorm prevailed, with 1.42 in. of rain. This was the first rain of the month.  
 18th.—Fine and pleasant and generally bright; lightning in evening.  
 19th.—Fine and pleasant, though cloudy at times, especially in the afternoon.  
 20th.—Overcast early, cloudy morning, then bright till about 4 P.M., followed by a heavy shower and unsettled evening.  
 A variable and unsettled week, terminating a period of ten successive weeks with a temperature above the average, being 7° colder than the preceding week, and about 5° colder than the average. The rain on the 16th terminated a dry period of seventeen days, and broke up the second drought of the summer.—G. J. SYMONS.



## COMING EVENTS

1	TH	Newcastle Show (last day). Paisley Show.
2	F	Fruit and Dahlia Show. Crystal Palace (two days).
3	S	
4	SUN	13TH SUNDAY AFTER TRINITY.
5	M	
6	TU	
7	W	Sale at Stevens' Rooms.

### BLOTS IN GARDENS.

**P**ERHAPS there are few gardens in which something cannot be found that fails to meet the approval of the critical spectator, who is at the same time a practical cultivator and a man of taste. It is beyond the power of any gardener to have everything just as it should be at a given time, simply because the controlling elements are uninfluenced by his will. And if a manager of admitted ability and with ample resources at his command cannot please himself in that respect it is not to be expected that one less favourably circumstanced can please others, and a blot more or less prominent will be apparent. But when the blots that mar the generally fair escutcheon are so few and obscure that they cannot be seen without a search, they only show in greater relief the prevailing excellence.

No doubt the impression conveyed of a garden is influenced by, so to say, the nature of the vision of the observer. Everything looks blue to the wearer of blue spectacles, and if a predisposition exists to find fault an object always seems to be created for the occasion. Whether it is singular or natural that such should be the case matters not; it is enough, and more than enough, to know that the proposition is true. Say something or do something that is not approved, or, to put the case stronger, resented, and what is done after that, however right and good in itself, is not always seen in its true and real colour and character. When the mind is made up to find fault, fault will be found, and whatever the intended victim may do to avert it will be vain. A person can find fault with anything, no matter what, if he desires to do so, and find blots at every step and turn. Nor is it difficult to magnify the smallest specks into almost hideous monstrosities. The existence of what may be termed those psychological peculiarities cannot be ignored, and no harm can be done in recognising them. On the other hand it is just possible that a measure of good may result, for it is conceivable, if not certain, that the mind may be unconscious of the possibility of error, even if that which is fair be made foul by the nature of the glass through which it is seen.

Gardens for the purpose of these notes will not be inspected under glasses that distort, nor is it necessary to make a minute search for a blot that exists in so many of them; it is absent from some, but apparent in most and flagrant in not a few. "What," may be asked, "is this terrible and almost ubiquitous blot that has been allowed to remain so long without a protest against it." The reply is, Protests have been many, but have not perhaps been so forcible, nor have had the prominence accorded to them that the subject demands. The blot in question is the

habit—the time-honoured, bad, thoughtless, and slovenly habit—of permitting worthless crops and useless growths to occupy space and ground for weeks, and in some cases months, after they ought to have been cleared away.

In gardens innumerable stately rows of Lettuces may be seen with stems 3 or 4 feet high, that are worse than worthless there, for it will be safe to say not one out of a hundred of them will ripen seed that will be gathered and applied to a profitable purpose; and if the saving of seed were the object, half a dozen plants would furnish more than enough for the whole of the demands of next year. That, however, is not the object of the cultivator of bolted Lettuces, and, as a rule, the utmost expected from them are a few crisp stems for pickling or preserving, and six plants would give these as well as six hundred. This crowding of gardens with useless growth not only seriously mars their appearance, but prevents the growth of something else that might be serviceable, at the same time draining the earth of its virtues in the most needless manner.

Again, it is not uncommon to see large spreading Cauliflower plants, some from which the heads have not been cut, hence assuming shrub-like proportions, while the leaves of others of the plants that have been cut expand in consequence to unusual dimensions, and there remain. What is the result? Unsightliness. It is that, and a great deal more, for it is not too much to say that in many cases the growth that is thus allowed and which is quite useless takes more virtue from the soil than was extracted in perfecting the heads that were cut and used. Such blots as those, with the attendant waste, ought not to be seen in gardens.

This is written in the full knowledge that scores of men whose duty it is to cultivate gardens and keep them in order are seriously overworked. Such men may justly plead they "cannot do everything." But if they have time to cut Lettuces and Cauliflowers they have time to pull the plants up. Then why cannot they be pulled as they are wanted, and the unsightliness and needless soil exhaustion prevented? It is a question of habit and nothing more. As to the surplus plants that are not cut, surely they can be more easily and quickly pulled and wheeled away when they are comparatively small than when as large again, and consequently make twice as many barrowloads, the land in the meantime being seriously impoverished. With a better system and more promptitude in action many an overworked gardener might save himself some labour, and at the same time conserve the resources of the soil, and contribute to the neatness that makes gardens so agreeable.

How many rows of dwarf Kidney Beans are there in gardens now that have ceased yielding crisp, fleshy pods for weeks past? No one can say how many, but a few readers will not have occasion to travel far to find some. Why are the rows left? For seed? Nothing of the kind. A few Beans may be saved, but the vast majority of the plants, more or less laden with ripening seed, will some day be cleared away to the rubbish heap, and with them at least ten times as much potash as was appropriated up to and during the time the pods were gathered for use. That was perhaps not thought about; all the more reason, then, that the fact should be mentioned.

Nor is the loss indicated the only result of leaving the useless plants to exhaust the soil and themselves. They become the host and the happy hunting ground of one of the most insidious and destructive garden pests—the red spider. Millions of these have been nurtured

this season by crops that ought not to have been permitted to encourage and support them. "Cannot help it," does someone say? "no time to pull them up." "No time!" How much longer would it take to clear away a row of the Beans than it took to gather the last dish that was used from the plants? It would not take a minute longer; indeed the plants could have been drawn in less time than could a "last dish" when fresh pods are scarce and have to be sought for over a considerable length of row. There may be many too old, but the existence of these, that ought not to be there, is sufficient evidence of the fresh ones being few, and the plants could be drawn in less time than the dish could be gathered; yet they remain week after week—for the spider.

Passing through a Peach house the other day the writer observed to his guide—"I see you have a little spider here." The trees were nearly devoured. The complacent reply was, "Yes, they came off them Beans." No doubt that was so, and "them Beans" on the border close to the front ventilators had not afforded a green pod for a month, yet every plant of them could have been cleared off in ten minutes, and tens of thousands of the "spider" kept at a distance from the Peach trees.

Negligence in removing waste vegetables and profitless crops does not pertain to the best managed gardens, but in many of the other kind this great blot is much too conspicuous to be overlooked.—OBSERVER.



#### LÆLIA ANCEPS IN THE OPEN AIR.

FOR several years Mr. A. H. Smee has grown many of the cool Orchids in the open air in his celebrated garden at The Grange, Wallington, with remarkable success. This year several plants were placed out as usual in June, and they all appear to be thriving better than ever. The recent hot days and cool nights seem to have suited them admirably, judging from the strong growths the plants are making, especially *Odontoglossum Alexandræ* and *Oncidium crispum*, some of which are forming their flower spikes. This season, in addition to those subjected to the above treatment, a few large pieces of *Lælia anceps* were placed out on a platform above a small stream, where they receive the direct sunshine, and during the middle part of the day the boards on which the plants stand have been almost too hot to place the hand on; nevertheless new leaves and bulbs are now partly made, and in almost every one the flower spikes are appearing. When in the houses they were of the ordinary green colour, but at the present time their character is entirely changed, the young leaves are a fine bronzy red without spot or blemish. Mr. Smee has an idea that the blooms, as well as the foliage, will obtain a deeper colour. The whole of the plants enjoy the heavy dews at night. During some evenings the leaves are as wet as though they had been watered with the fine rose of a water pot.—W.

#### THE GLEN, LEWISHAM.

THE admirable collection of Orchids in the possession of Dr. Duke is still increasing, and year after year he has to build more houses to accommodate his treasures. Probably in no other garden could Orchids be seen packed so closely together in such numbers, for the pots are touching each other on the stages, and the pans, blocks, and baskets, are hanging on the wires above as thickly as it is possible to get them; not an inch of space is wasted. In the *Odontoglossum* house, although the stages are wide, it is necessary to run a wire from end to end to prevent the plants falling off. This may appropriately be termed a houseful. One would hardly expect to find such luxuriant growth and bloom from this kind of treatment, but it is a fact that the plants are flourishing at least equal to any in the most noted establishments, where they are arranged with scarcely the foliage of one touching its neighbour. *O. madrense* has made large bulbs, and is flowering. A small

house, the roof of which is devoted to *Barkerias*, is a remarkable sight. There they hang in baskets and on blocks, with splendid growths and a forest of roots. The leaves are quite close to the glass, and receive the greatest amount of light without direct sunshine. They are liberally supplied with water during the growing period, and in addition, the mass of plants beneath most certainly give up a natural moisture, which greatly benefits those above. When required, a hot-water pipe is at command just under the roof.

The *Phalænopses* are in an adjoining house, with *Dendrobiums* growing freely, and the new *Cœlogyne Forstermani* and *C. Sanderiana* breaking strong in fine specimens. The old *Cattleya* house contains some large plants of the useful *Cœlogyne cristata* in its several varieties, *Lælia anceps*, and a host of other kinds. In the new house, where there are side tables and a centre stage arranged in ledges one above another, are hundreds of *Cattleyas*, *Lælias*, &c., showing sheaths, while a few are in bloom, including a fine form of *C. Sanderiana* and an equally good *C. crispa superba*.

The show house is in three divisions, and considering the time of year presents a lively appearance, being tastefully arranged with *Caladiums*, *Maidenhair Ferns*, &c. One of the first objects to attract the visitor's attention is a fine specimen of *Oncidium Harrisoni* in a pan carrying ten strong spikes with numerous blooms; *Cattleya bicolor*, *C. eldorado splendens*, *C. Gaskelliana*, *C. Leopoldi*, *C. gigas*, and *C. velutina*, *Aerides japonica*, *A. Fieldingi*, *Cœlogyne speciosa* (Horsman's variety), having green petals changing to bright yellow, chocolate throat, with a pure white lip; this is far superior to the ordinary form; *Odontoglossum bictonense alba*, *O. cordatum*, *O. Pescatorei*, *O. Uro-Skinneri*, *Oncidium dasytyle*, *O. crispum*, *O. longipes*, *O. Warneri*, *O. tigrinum*, *Promenæa Russelliana*, *Trichopilia fragrans*, *Lælia xanthina*, and *Cypripedium Lawrenceana* attract notice. Also showing flower are *Cattleya Dukeana*, described by Professor Reichenbach to be intermediate with *C. bicolor* and *C. Leopoldi*; *Cattleya Boweringiana*, one of Messrs. Veitch's plants, look distinct from those recently imported, and some of which are growing well. In another house *Miltonias* in variety are also showing well for bloom.

In the lower division, with a few choice stove plants, are the *Odontoglossum vexillariums* in numbers, and *Cypripediums*. Among these are healthy established plants of *C. Sanderiana*. In another house plants of *Oncidium Jonesianum* are doing well on bare blocks of wood. *Phalænopsis Esmeralda* is represented by several plants growing very cool, and making large leaves and thick fleshy roots. Another span-roofed house is in course of erection for *Cattleya gigas*. Of this there is a fine lot. Dr. Duke is a skilful grower, and a close observer of the wants of each in this beautiful family of plants, and he may well be proud of such a rich collection.—G. W. C.

#### PHAJUS GRANDIFOLIUS.

EVERY attention should be paid to encourage a strong vigorous growth of this useful old plant, for upon this depends the strength of the flower spikes. Plants with luxuriant growth will produce flower stems 4 feet in length, and have a conspicuous appearance in early spring either in the Orchid house or in association with decorative plants in the conservatory. For grouping for effect few plants are equal to this. To insure strong growth the plants should be liberally supplied with stimulants in a weak state. For this purpose clear soot water and liquid made from cow manure will be found most beneficial. These stimulants can be given alternately every time the plants need water at their roots.—G. P.

#### CALANTHES.

THE earliest batches of these plants will have made large pseudo-bulbs with healthy luxuriant foliage, provided they were strong to commence with, and have since been liberally treated. It is not unusual to find the largest of pseudo-bulbs, through not being well ripened, only producing very ordinary sized flower spikes. This non-ripening is a serious drawback. Growth produced late in the season when there is an absence of light, or when it is prevented reaching the plants by overshadowing, is certain to result in degeneration. More *Calanthes* have degenerated through immature growths than from any other cause. To grow and ripen the plants well they must not be started into growth late in the season, but early, then gradually ripened after the completion of growth. Premature ripening is an evil that must be avoided. Water must not be suddenly withheld, as is too frequently the case, but gradually, and with caution; in fact, the supply must be diminished on the same principles as it is given to the plants during their first stages of growth. Light and air must also be increased, so as to bring the growth of the plants to a standstill as naturally as possible. This treatment will insure successful results, while the opposite will sooner or later end in failure.—B. W.



## CYPRIPEDIUM PRÆSTANS.

THIS very interesting *Cypripedium* was shown by M. Linden of Brussels at the last meeting of the Royal Horticultural Society, and attracted much attention by its being introduced from New Guinea. It presents a peculiar combination of the characters of several species—*C. Stonei*, *C. Roebolini*, and *C. Parishii* being all represented in some portion of the flower, but the resemblance of the lip to that of *C. Stonei* is very marked, the sepals and petals partaking more of those of the other two species. The dorsal sepal is light yellow with dark bars, very distinct and clearly defined; the petals are 4 or 5 inches long, twisted, and undulated at the base, which is green with a dark central bar margined with a number of dark beads and a few hairs; the upper portion of the petals is green, slightly veined with a darker shade. The lip is pale green, with fine slightly darker veins, and the staminode is of a darker yellow tint than the rest of the flower, with small nodules at the side and a fringe of fine hairs. Though the plant exhibited was small, a vigorous habit was indicated, and *C. præstans* promises to make a fine addition to the list of these Orchids in cultivation.

We are indebted to M. Linden for the following particulars:—*Cypripedium præstans* was introduced into Europe at the beginning of December, 1886. Professor Reichenbach, who described it soon after its arrival, from some specimens preserved in alcohol, announced it to the orchidists as "a very great surprise." It had formed part of an important consignment from New Guinea sent by the Lindenian collectors, who were then, and still are, exploring that mysterious island, so rich in beautiful plants of all species, but so dangerous to "open up." This consignment, which was expected to contain other marvelous species of *Cypripediums*, *Vandas*, *Phalænopses*, *Dendrobiums*, &c., arrived in Europe, after numerous delays, while severe frosts were being experienced, and very few plants could be saved; nearly all perished with the exception of a few dozen of *Cypripedium præstans* and a few other Orchids. In the month of March the surviving plants passed into the hands of the new Society just founded by Messrs. Linden at the "Parc Leopold," Brussels. This new establishment, constructed specially for the introduction of Orchids, will be inaugurated at an early date, and will be of great importance. The company, which has taken over existing missions in search of new plants, and organised several others, received in May

of the present year from the same quarter of New Guinea, a fresh consignment, which arrived this time in the best condition. Amongst other species of great value were some fine roots of *Cypripedium præstans*; this species is thus now perfectly represented in Europe. It was in the month of June last that a specimen of the first importation flowered for the first time. It was a plant much more vigorous than that which appeared at the meeting of the 23rd of August at South Kensington. The flower stem bore five large blooms expanded at once. This inflorescence has been sent to Professor Reichenbach after having served for the portrait which will appear, together with *Catasetum Bungerothi* var. *Pottianum* (a charming variety, dotted with carmine, of that other beautiful introduction due this year to the investigations of

the Lindenian collectors) in "*Lindenia*" at the commencement of the present month.

## SOBRALIA MACRANTHA.

THIS is a beautiful Orchid, and although the individual blooms do not last long, others quickly follow, therefore a succession is produced over a lengthened period. It is a plant of comparatively easy culture, and may be successfully grown in an ordinary plant stove; in fact, the conditions of such a structure appear to suit it exactly. It will also thrive satisfactorily in the East Indian house (with *Aerides*, *Vandas*, *Saccolabiums*, and other heat-loving plants),

where the winter temperature, from October to March, ranges from 65° to 70° at night, according to the weather, with a rise by day of 5° or 10°, the summer temperature of the same structure being kept 70° to 75° at night, and 80° to 90° by day, or even higher by sun heat. *Sobralia macrantha* will also grow luxuriantly in the Mexican house with many *Oncidiums*, *Cattleyas*, *Lælias*, and others that require a winter temperature of 60° at night, falling 2° or 3° towards morning during severe weather; summer temperature, 65° to 70° at night, with a rise of 10° or 15° by day. It would be difficult to say under which of these conditions it does best; we prefer, however, to subject our plants to the temperature of the Mexican house.

During the season of growth it requires a moist atmosphere and light shade, but the plant must only be protected from the strong rays of the sun. Overshading must not be practised, for abundance of light is essential to solidify the growth as it is made, and such growth is essential for free

flowering. Liberal supplies of water should be given and the foliage syringed, but during the season of rest considerably less water is needed; in fact, only sufficient to keep the roots and stems healthy. The supply must be gradually increased as the season advances, as well as the amount of moisture in the atmosphere, and at the completion of growth it must be carefully and gradually diminished.

In potting, the compost should not be raised above the rim of the pots, as is the case with many Orchids. It is best grown in pots, drained, say 3 inches in a 12-inch pot, and more in proportion according to the size used. The compost should consist of rough fibrous peat in which moderate-sized lumps of charcoal may be freely intermixed. When

plants become too large they bear division much better than many Orchids, and if this is done just before the roots start growing, good flowering plants soon become established.—M. B. S.

## ODONTOGLOSSUM VEXILLARIUM.

VARIETIES of *O. vexillarium* are numerous, but one, of which a flower has been sent by Mr. James Cypher, is very distinct and pretty. It is one of the medium-flowered forms, with bright rosy petals; the sepals lighter but well proportioned; the lip large, deep crimson at the base, white at the margin, and the upper part rosy purple. It is a well-shaped flower, but the colouring renders it remarkable.

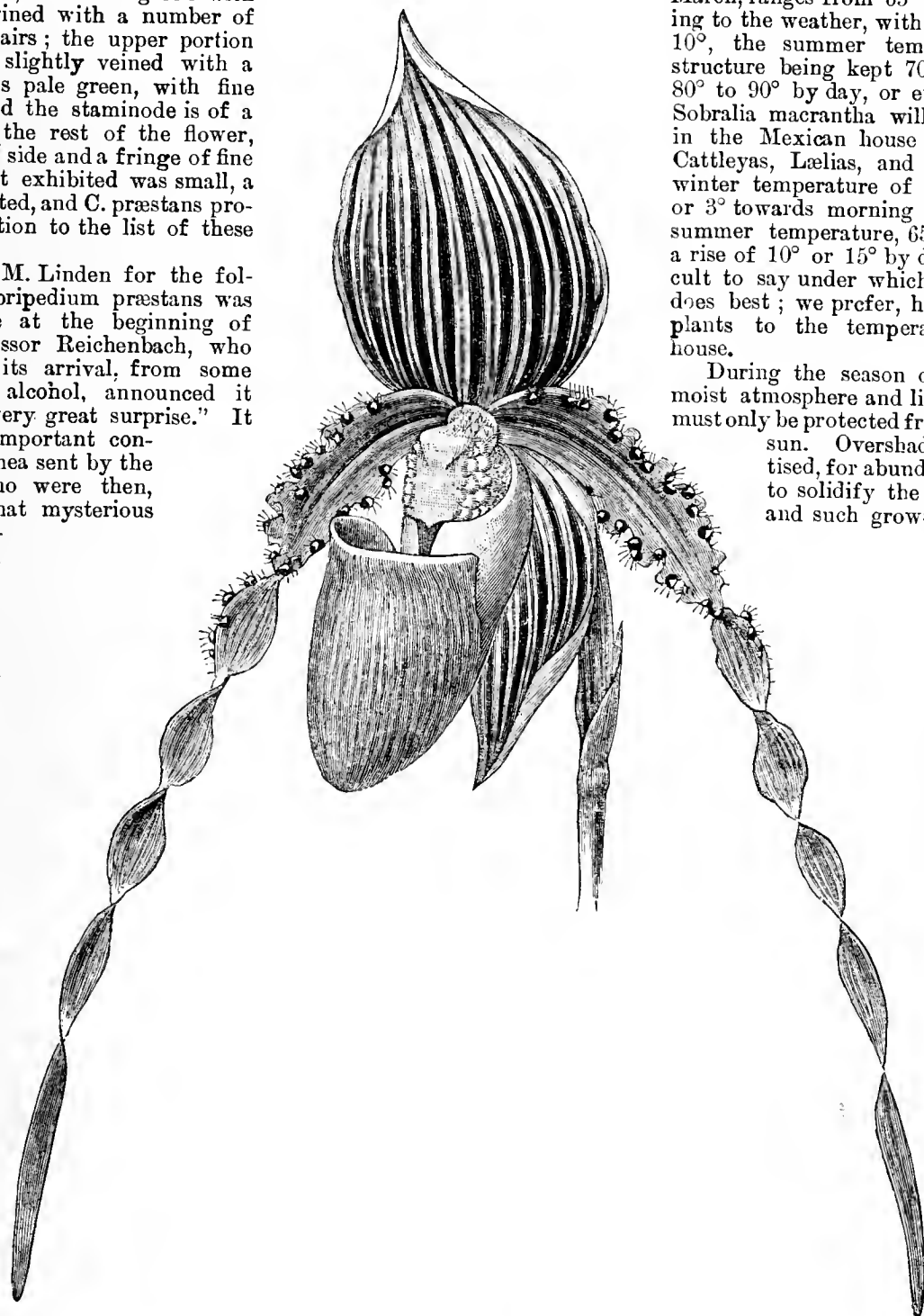

Fig. 24.—CYPRIPEDIUM PRÆSTANS.



**RAIN IN LONDON.**—Rain fell heavily in the metropolitan district for several hours on Tuesday night, and will be of incalculable benefit in parks, gardens, and fields.

— WE shall be glad if any reader who may happen to possess a spare copy of the "GARDENER'S YEAR BOOK FOR 1879" will forward it to us or to Mr. W. Watson, Royal Gardens, Kew, it being required to complete the set in the Herbarium library there. Stamps will be sent for a copy of the work on its arrival.

— **THE CRYSTAL PALACE.**—The National Dahlia Show, together with the exhibition of fruit, that will be held at the Crystal Palace on Friday and Saturday in this week, will together form a display of considerable magnitude; and the occasion will be opportune for gardeners and all who are interested visiting the famous building and attractive grounds. The last of the outdoor fêtes and beautiful illuminations, which have attracted upwards of 800,000 spectators, will be held on Saturday evening.

— WE are informed that there is a very fine display of **BEGONIAS** in Mr. Robert Owen's Floral Nursery, Maidenhead, at the present time well worthy of inspection.

— WE are asked by **MESSRS. WM. WOOD & SON**, Wood Green, to announce to intending competitors for the silver cups offered by them at the Crystal Palace and South Kensington Shows in October for Potatoes and vegetables, that they will undertake to stage exhibits for competitors at a distance who are unable to attend, if communicated with at an early date.

— "**A SOMERSETSHIRE FRUIT-GROWER**" writes:—"I have long been an admirer of the **DUCHESS OF OLDENBURG APPLE**, and am therefore agreeably surprised at the way in which it withstands a severe drought. Comparatively young trees invariably bear well; at any rate they have not failed to do so for several years past, and this season the crop is quite as good as usual. Rather fewer fruit were borne on the trees, but these, strange to relate, are considerably larger than usual, and beautifully streaked with red. Although not really a good dessert sort, the fruits are of a most tempting appearance and sell well. Though naturally light in weight, some of the best fruits weighed 7 ozs. each. All had to be gathered last week, or the blackbirds would have spoilt them. This Apple should be cultivated by both market growers and the owners of small gardens."

— **THE WILSON JUNIOR BLACKBERRY.**—Mr. J. Windsor sends us from Glangwna, Carnarvon, an excellent dish of this variety, of which he speaks with approval. The fruit is good, but not larger than that of the Parsley-leaved Bramble as grown by Mr. Woodcock near Sheffield and Mr. Carter at Keighley.

— "**G. W. C.**" writes—"There is a **GRAND DISPLAY OF ANNUALS** just now in the garden of G. Gibbs, Esq., at Anglesey House, Carshalton. Phlox Drummondii range in colour from the brightest crimson to snowy whiteness; Asters and Stocks are magnificent both in colour and size; Zinnias are also very good. Of Petunias I have never seen a better lot; the strain (Carter's Emperor) is superb, some are planted in beds, while others are isolated on a rockwork border; they spread over the stones and are a mass of bloom, several of the plants measuring 2 feet in diameter. I enclose a few blooms for your inspection. The one with a green edge is very attractive, the plants of this being sturdy and free-flowering. Although the annuals are so good other things have not been neglected, the houses and kitchen garden bearing evidence of the good management of Mr. T. L. Cummins, the gardener." The Petunias received are very fine indeed.

— **A DRY-SEASON STRAWBERRY.**—A Kentish gardener mentions the fact that Strawberry Elcanor or Oxonian, as it is also named, has

done remarkably well this season. A very fine crop of fruit was perfected on the plants growing alongside a path in the kitchen garden adjoining Hawkhurst Rectory; no other sort succeeding so well under similar treatment. The plants only received one good soaking of water, but being comparatively young and rooting in good ground, they produced exceptionally heavy fruit. Mr. Iggulden generally secures fine crops of this variety, but in dull or showery seasons the quality is not nearly so good as during a hot summer. It is one of the latest in ripening, and ought to be included in most collections.

— **BEGONIAS FOR BOUQUETS.**—At the Taunton and Weston-super-Mare Horticultural Exhibitions Mr. B. R. Davis had a fine display of cut blooms of Tuberosus Begonias, as well as a considerable number of buttonhole and hand bouquets composed exclusively of Begonia blooms and Maidenhair Fern. Being both novel and striking this naturally attracted much attention from the numerous visitors to the Shows, and in all probability will lead to the more general employment of Begonias in a cut state. Quite a charming bouquet can be formed with them, and seeing how many and beautiful are the shades of colour available, it ought to be possible to please the majority of tastes. They may not be quite so serviceable as many flowers now similarly employed, but if properly wired they last even better than we anticipated, and are certainly more "taking" than Zonal Pelargoniums.

— **STRAWBERRY RUNNERS FOR FORCING.**—Mr. A. Young writes:—"It has been rather difficult this season to get early runners for forcing, as pointed out by Mr. R. Inglis at page 133. I have practised his mode of procuring them there described, but it has this disadvantage, it causes the crowns to split, and for this reason I prefer the current season's runners, even if a little later."

— **GARDENING APPOINTMENT.**—We are desired to state that Mr. G. Hilton is the gardener at Smithhill's Hall, Bolton-le-Moors, and not Mr. G. Wilson, as was announced in this Journal. It is very desirable that the names of persons be plainly written, then mistakes of the nature indicated would not occur. Names of plants, if not clearly rendered, can usually be recognised, but not the names of individuals.

— **TOBACCO GROWING IN LINCOLNSHIRE.**—Mr. John Graves of Skirbeck, Boston, Lincolnshire, has grown one acre of Tobacco this year, and, being a novelty in the district, it has been visited by large numbers of people. The field was planted from the 10th to the 15th June. Considering that it had only one good rain it made very rapid growth, and was 4 feet high when topped on the 1st of August. Gathering for curing began on the 15th inst. Competent foreign Tobacco growers who have seen it state that it is a magnificent crop of Tobacco.

— **MR. W. K. WOODCOCK**, writing from Oakbrook, Sheffield, on the **COLOURING IN SHRUBS**, observes:—"Shrubs having golden variegation are extremely bright this season, especially the Golden Yews, Irish and English, Golden Hollies, Golden Elder, Retinosporas, &c. We have here probably the four finest trees in existence of the Golden Irish Yew (*Taxus fastigiata aurea variegata*), planted by their Royal Highnesses the Prince and Princess of Wales in 1875, and these specimens have been since June much brighter in colour than we have before seen them, and extremely beautiful. The growths they have made this season are also satisfactory, more so than in any previous season. The Golden English Yew (*Taxus aurea*) is also very bright in its colouring, and has made exceptionally strong growths. Our hardy shrubs are mostly planted in good soil with a more or less stiff clay subsoil, and with the exception of Rhododendrons, which are suffering much from the drought, have nearly all made very strong and satisfactory growths."

— **REFERRING TO A HEDGE OF GOLDEN YEWS** our correspondent continues—"It deserves to be more generally known than I believe it is that the Golden English Yew referred to above is a singularly effective shrub for the formation of hedges in ornamental gardens. In June last, being on a short visit to some friends of the craft in Blackburn, we were much impressed by the grand effect produced by a hedge we saw in the beautiful gardens of Mr. Tatershall, Quarry Bank, Blackburn. The gardens, full to overflowing as they are with good things, and splendidly managed, deserve more than a passing notice; but for the present we can only allude to this very beautiful hedge, which, as near as we can recollect, is about 20 yards long, 4 to 5 feet high, and 3 feet through. It has a low rounded convex head with straight sides, kept

closely clipped, and from the time that new growth has commenced in early summer until autumn the bright effect produced is very striking, and as it is planted upon a hillside it is distinguishable at a considerable distance away. We were also struck by the varied tints of yellow ranging from light yellow almost to bronze produced by the different shrubs (seedlings) constituting the hedge, and which improved the general effect. We strongly recommend it to planters."

— A VISITOR to KNOWSLEY HALL GARDENS writes: "Gardeners and others who have any doubt about digging annually round the roots of fruit trees, such as Peaches, Plums, and Cherries, grown under glass, should inspect the Plum house at Knowsley. The condition of the trees and the enormous crop of fine fruit they are carrying are sufficient to remove all misgivings from the minds of those who question the soundness of this method of culture. The Cherries and Peaches are in the same admirable condition as the Plums. The trees look excellent, and the fruit has been in each instance of the highest quality. Finer fruit or trees, especially in the case of the Peaches, it would be impossible to find in any part of the country."

— MANY of the readers of the Journal will doubtless know NEWTON DON, near Kelso, N.B., and knowing the place, must know the genial gentleman who, for the last forty years, has managed the estate for the Balfours. They will be sorry to learn that Mr. Thom has been obliged to resign the position he has so long and so worthily occupied on account of increasing infirmity. Mr. Thom is a very keen, earnest, and thorough gardener, and when the bedding-out rage was at its highest, the pretty flower garden under his charge was kept in the highest order. The old herbaceous borders were, however, never done away with, but among the other plants selections of Pentstemons, Phloxes, Delphiniums and other florists' flowers were grown, while rows of the newest and finest Dahlias and Hollyhocks, backed with glorious lines of Sweet Peas, made these old borders features of the garden which once seen were never forgotten. Though for a great number of years Mr. Thom never exhibited, he continued to grow florists' flowers to the highest perfection, Dahlias and Hollyhocks being his favourites. The wall trees under his charge, more especially the Apricots and Peaches, were always pictures of health and fruitfulness. Vegetables were also extremely well grown, some of the strains being selections of his own, which he had kept for long periods. Mr. Thom never forgot a man who he found endeavoured to carry out his wishes, and not a few gardeners in good situations to-day have to thank their old master for bearing them in mind when an opportunity occurred to do them a service. All such and many more of his friends will cordially join in wishing him a peaceful resting time after so many years in harness. We understand that Mr. William Wood, who for the last few years has efficiently fulfilled the duties of inside foreman in Lord Haddington's Gardens at Tynninghame, East Lothian, has been appointed Mr. Thom's successor as gardener and estate manager.

— THE MUSCAT GRAPES at Knowsley are again very fine. The bunches are not large, but the berries are, while the former are all that can be desired for home consumption. The bunches are splendidly coloured throughout the two houses; the laterals are kept well pinched back, and a subdued light reaches the fruit. Mr. Harrison, the able gardener, does not believe in removing the foliage or tying it back, for such practice results in the shoulders and side next the sun being coloured and browned, while the remaining portion of the bunch is anything but a golden amber colour, such as those at Knowsley are. Black Hamburgs are also excellent in the size of the bunch, berry, and in colour. Gros Maroc is specially fine grown with Hamburgs, the bunches were not large, but the berries were of enormous size. Some ladies who have had this Grape say it is a superb one for invalids. Those who express this opinion have had Grapes of the very best quality for years, and are therefore capable of passing an opinion.

— "W. B." writes:—"It is questionable if any variety of CUCUMBER excels Veitch's variety of the Telegraph. For some years we have tried it by the side of many others, and prefer it. It fruits early, and with good treatment will continue to yield abundantly throughout the season. The fruits are straight, about 18 to 20 inches in length, and highly esteemed in the market."

— THE same correspondent observes that "M.P." POTATO has done better with him this season than any other variety. "The early

varieties generally were much lighter than usual, and smaller in size. M.P. is a second early, and the dry weather has not affected it in the least, for the crop is heavy, and the tubers large, and nearly all of one size. It is a beautiful white Potato, and the quality all that can be desired."

— DWARF PEAS.—A gardener writes to us, stating:—"I have grown American Wonder, Chelsea Gem, and William Hurst (Laxton's), and am decidedly in favour of the last-named variety. Hitherto I have been of the opinion that American Wonder was the best dwarf Pea in cultivation, but if William Hurst behaves in the future as it has done this year, it will take the place of the former variety."

— THE same gardener informs us that amongst others that attain a height of 2 feet 6 inches, ABBOTT'S DUCHESS PEA must in the future take a prominent position, for it has cropped heavily in moderately light soil. The pods are very large, containing from nine to eleven peas. They were sown on deeply worked land that had been well manured. The rows were never watered, and did not display the least signs of suffering by the drought.

— A VISITOR says:—"The MADRESFIELD COURT VINE grown on the extension system at Garston, and which now fills two houses, has this year carried two hundred bunches, some of them weighing 2½ lbs., while the whole would average considerably over 1 lb. The majority of the roots are outside."

— TREE PLANTING IN LONDON.—A striking and beautifying change in the aspect of London is being wrought by the continuous planting of trees. The few trees that existed a quarter of a century ago were the old trees in the parks, some of the squares, and here and there veterans left in churchyards. They were mostly Elms, stately certainly, but sombre, with their dark trunks and their bright spring foliage rapidly turning to a dark green, made dingy by the smoke. Horticulture was then, perhaps, at its lowest. Plans of old London show many fine avenues of trees and many spaces laid out as gardens. But as old trees died they were not replaced, and the grounds were seized by the speculative builders. Now everything is changed. Flowers abound in all districts, rich and poor. The owners of houses in the wealthier districts appear to vie with each other in producing the most beautiful floral displays, which not only enliven their own rooms, but brighten the whole neighbourhood. In the poorer districts unpretending window boxes or pots of plants, which yield so much pleasure to those who take care of them, are everywhere to be seen, and the parochial flower shows for window gardening which are at this time of the year being held furnish testimony to the amount of tender care that has been bestowed. The more enduring changes have been the substitution of the Virginian Creeper for Ivy, and planting with Plane trees instead of Elms. The Creeper is everywhere brighter than the Ivy. To estimate the number of Plane trees planted in London since the formation of the Thames Embankment would be almost hopeless. They are to be met with along all the main thoroughfares to the suburbs, in our broad avenues and newly formed streets cut through old slums, in churchyards, and at most "crossing refuges" large enough to hold one. No tree seems to thrive better in London. Since 1884 forty-six gardens and grounds have been opened under the auspices of one Society alone.—(*Echo*).

#### THOUGHTS ON CURRENT TOPICS.

THE weather having cooled somewhat thinking becomes a little less difficult and writing less irksome; yet if all were alike prone to self-indulgence and to make no effort against yielding to repose the columns of the Journal would never be filled. I feel I must reproach myself for not being more energetic; but I have been very much like some gardens—nearly dried up, and am not quite sure that this dryness will not be apparent in these jottings.

THOUGH the weather has been so exhausting to plants and their cultivators, and a great deal more than inconvenience has been experienced by gardeners, farmers, indeed by nearly everybody, I still think it is a good thing that seasons like the present occasionally recur for reminding us of neglected duties and warning against a continuance of taking things easy. The population is ever increasing, and of necessity the demand becomes greater for the requisites of life. The greatest of these is water, yet in years of abundance there is a disposition on the part of individuals and corporate bodies to be lulled into a state of false security; and not a few have narrowly escaped a severe penalty this year for past apathy. The possibility of a rainless summer is forced on public attention now, and endeavours will be made to provide for such a



contingency ; but as I cannot exactly see how a supply of water can be had "for nothing," I am thinking of reading Mr. Shirley Hibberd's pamphlet on this important subject.

LAST year a very interesting discussion was conducted with great ability in the Journal as to the relative advantages of trenching or not trenching land for cropping purposes. A generally accepted decision did not appear to be arrived at at the time, and further experience seemed requisite for testing the different methods that were advocated. The soundness of propositions is tested by the strain to which they are subjected. There has been a great strain on vegetation lately in consequence of excessive heat and protracted drought. Under what circumstances has the strain been best endured? After thinking over the matter I made a point of "interviewing" those exhibitors of high class vegetables that I happened to meet at a few shows visited during the season, and I am bound to say that deep cultivation was recommended in every instance, supplemented by surface mulchings. I by no means imply that the result of my inquiries settles the point, as they have been limited to about thirty successful competitors, yet it is significant that all of them were of one mind on the subject. If our surface-tickling or spade-deep friends have powerful rebutting evidence let it be produced.

Now a thought on mulching. Much good has resulted from it during the season, and the most when the mulching was applied the soonest. In my opinion the practice is often deferred for weeks too long. Anyone thinking the contrary is respectfully invited to mulch half a bed of Strawberries in April and the other half in June. Even if the season should not prove exceptionally hot I shall be very much surprised if the earliest mulched part does not afford the greatest weight of fruit, while in a dry summer like this the evidence in favour of the early action will, I venture to say, be incontestable. It is the same in respect to other crops, and I now desire to suggest for the consideration of cultivators that mulching, as a rule, might be resorted to much sooner than usual with very great advantage. Action will, of course, be determined by the weather, but I am convinced that it is easier to err by putting off the work too long than by commencing it too soon. What think others?

ANOTHER subject to which I desire to give a moment's thought is that of watering crops in hot weather. Is not much water wasted and time misspent in daily dribblings? An example will enable me to put the case in a few words. An ardent amateur sowed some rows of Dwarf Kidney Beans towards the end of April. He had full rows of plants, and every morning all the hot weather, after he had his breakfast, he gave his precious Beans theirs. Not a plant in the bed attained a height of 6 inches, and instead of the attentive cultivator growing anything approaching to half a crop of Beans, he grew a horde of insects. A more miserable failure it would be difficult to imagine, and all through over-zeal and the misapplication of water. If the ground had been mulched in May and not a gallon of water used, or rather wasted, there would have been ten times more Beans and a hundred times fewer insects. The daily evaporation of probably nine-tenths of the water that was given so lowered the temperature of the ground that the plants, paradoxically as it may seem, perished through cold under a burning sun. The roots could not work in the cold medium, and hence the stunted growth. The soil was good, but spoiled. Had half the quantity of water that was sprinkled on the bed as described been applied on an evening once a week, and the surface of the ground loosened with the hoc the next morning, failing mulching, the disaster indicated would have been averted. Frost can be induced by evaporation if the sun be hot enough, and the roots of the ruined Bean plants were in a temperature not far above freezing, while the leaves had to endure 140° or more in the sun. What wonder, then, at the collapse of the plants? It is feared that many other plants of various kinds have suffered in many gardens through the very means that it was hoped would promote their growth. The subject of watering demands much more thought than I can devote to it now ; but there are plenty more thinkers, deeper thinkers, and clearer writers than I am, and I hope this confession will comfort a correspondent who once affected to hope I was not, to coin a term, a mental monopolist. I plead guilty to monopolising a little space now and then, and can endure the penalty that may be imposed for the usurpation.

THE present summer has afforded an excellent opportunity for observing the kinds of plants and sorts of vegetables that have best endured the drought. "J. H. E." has introduced the subject on page 132, and there is not a doubt if other cultivators would record observations of the same nature that interesting and useful information would be forthcoming, for many persons would be glad to know of the best shrubs, flowers, and vegetables for dry positions. As flowering shrubs and trailers the Hypericums have stood the drought well, as has the not half sufficiently grown summer-flowering evergreen *Olearia Haasti*. Petunias have been extremely floriferous ; *Zinnia Haageana* brilliant ; and the little *Tagetes* like a sheet of gold, while the leaves remained fresh and green all through the drought period. One of the best drought-resisting Peas I know is Laxton's Omega. Why is it not more grown? It will be seen I am willing to practise in a small way what I preach, and should be glad if a few more of my brother blue aprons would preach a little more of what they practise—not, however, following in my bad example of spinning long yarns. It has been said there is hope of a person improving who knows his faults, and therefore I will not

despair, though I am not yet under sufficient self-control to pull up just as I could wish when the thinking cap is donned and the scribbling fit upon me.

No small amount of anxiety seems to have been prevalent amongst gardeners as to procuring Strawberry runners early enough to develop into strong plants for forcing. The subject is of practical importance. It may be admitted that it is not safe to rely on old bearing plants for producing early runners, as their crops demand all their resources, and young plants that have not yet fruited are very superior for the work in question. Failing these, however, does not the plan mentioned by Mr. Inglis of establishing plants from late runners this year and potting them early next season to some extent meet the difficulty? It is a method worth trying and a very old one. I remember its being adopted more than twenty-five years ago, and with very good results, after a selection was made of the plants so potted, for some of them were characterised by "split crowns" that are not coveted in the preparation of plants for forcing. Yet by carefully thinning the clustered crowns most of the plants may be brought into fairly good condition for early bearing. Mr. Inglis does not refer to the crown-splitting tendency of the plants raised as he has described, and a supplementary note on the subject would not be unwelcome.

WHILE thinking about Strawberries the subject of barren plants comes to mind. Mr. J. Muir, who is nothing if not emphatic, has said that inferior culture is always the cause of barrenness, and that high culture will always bring good crops of fruit. I do not pretend to quote his exact words, but that is their meaning. His advocacy of high culture may be generally endorsed, but I think I have seen Strawberry plants as luxuriant as they could be grown that refused to produce flowers. The stock was raised from a very strong yet barren plant, and grown for testing the theory of the late Mr. Robert Fish. The plants were kept for six years and young plants raised from them, but neither young nor old flowered, though others in the same beds afforded full crops of excellent fruit. I think there is something in propagating from fruitful plants that are at the same time healthy, and I also think it is possible to induce over-luxuriance at the expense of fruit. I remember having what was considered a wonderful crop of the President. A Strawberry fancier, who grew fruit of the British Queen and some other varieties, that I have never seen excelled, desired runners of my President. These he had and planted in his deeper and richer ground. They grew astonishingly. I never saw such gigantic plants, but they never produced a crop worth gathering, and after three years of patient waiting were chopped up.

I LIKE the plan recommended by Mr. Bardney of taking healthy runners from fruitful plants, and growing a given number of these for producing runners only, picking off the flower trusses the first season, as I have found that plants so raised and well grown are capable of affording a full crop of the finest fruit within twelve months after planting, and if these are planted together triangularly with clear intervals of 2 feet between the "clumps" in July, they will have the appearance of two or three-year-old plants the following June, and as great a weight and value of fruit may be had of the ground as two-year-old plants can produce planted singly. For gathering the best crops of the finest fruit in the quickest time, I have found no plan equal to that just described, and I have tried every one that I have seen recommended in the Journal during the past twenty or thirty years.

CONTROVERSY has not been a prominent feature of the Journal this hot summer—not perhaps, as a correspondent appears to suggest, quite prominent enough ; hence he seems to be interested in the literary duel, with a respectable interval between the shots, of Mr. Abbey and his opponent, who intimates that all his teachings are founded on experience. It may be supposed that he is not quite singular in that respect ; indeed the two disputants appear to be very much on an equality on the point ; but what is particularly curious is this—they try to prove each other wrong, while each claims his opponent as a supporter of himself. That being so, and it is clearly enough expressed, it is not easy to see whether they are struggling for supremacy in what is wrong or what is right. It is a peculiar case, and perhaps I had better leave it, or both of them may be turning their guns on myself, and in that event there would soon be an end of—A THINKER.

### WASPS AND THE FRUIT.

WASPS are plentiful this season in the north I believe, but in some parts of the south reports say they are scarce. In this locality, however, they are numerous, and together with blackbirds are doing much damage to the fruit. I do not know of any means wherewith blackbirds can be kept from the fruit except by netting the trees, and in large orchards this cannot be done very well. One can greatly diminish the number of wasps by destroying their nests. If the nests are not already known to the gardener or others interested, they can soon be found by watching the wasps when on the wing and tracing them home. The easiest way I have yet tried in destroying them is to roll a piece of rag together about the size of one's finger, saturate it with turpentine, place the rag in the hole leading to the nest, and cover it with soil to keep the air out. This should be done about six o'clock at night. Nothing further is required, but if the nest be dug out next

day every wasp will be found dead. They can be destroyed in this way in all places where the air can be excluded.—G. GARNER, *Amberwood Gardens, Hants.*

### MR. ALEXANDER HILL GRAY AT HOME.

BEAULIEU, NEWBRIDGE-IN-BATH.

THERE are few Rose lovers to whom the name of this enthusiastic Scotchman is not well known, and the readers of the "Rosarian's Year Book" will not fail to remember the amusing and instructive articles that he has written, both of his experience in Rose growing and Rose showing in Scotland, and also of his explorations in the Azores, &c. There are many, too, to whom he is well known personally, who have enjoyed the wonderful stories he has to tell of his experiences in all parts of the world; of a three-years sojourn in the diamond fields of South Africa, of adventures in Borneo and the Golden Chersonese, of the share he had in the scenes of the Indian Mutiny, and of "hair-breadth 'scapes by flood and field." When, then, I found after the Taunton Show that I had a day at my disposal I determined to accept his kind invitation and "beard the Douglas in his hall," for it is in Bath, or rather close to it, at Newbridge Hill, that he has now located himself.

When his little boy was asked some time ago what he would like to be, his reply was, "The same as father." "And what do you think that is?" "Why, growing Roses;" and I do not think a truer description of the bent and purpose of Mr. Gray's life could be given, only I should have interpolated "Tea" before the Roses. He has been living at Dunkeld in Perthshire, but finding that that northern climate was far too bleak for his favourites he determined to migrate south, and, like most of those persons who form an ideal of what they want and then go to look for it, he found it very difficult to get what he wanted. He had to consider a home for himself and a home for his Roses. He had to be near a railway, and not far from a town; not that he cared much about a place being secluded, for he has lived so much of a hermit life in his wanderings that, while one of the pleasantest of companions, he hates the conventionalities of ultra-civilised life, but there are conveniences connected with large towns which cannot be ignored. He searched over the southern counties—Mid-Kent, Surrey, and Sussex, hunted up everything that was offered for sale, and at last has pitched his tent near to Bath. But even now he has not obtained all he wanted, for the soil in the neighbourhood is not a Rose soil. But I have ever maintained that this is a matter of secondary importance; if you have climate you can make soil, and the climate of Bath is admirably adapted for Rose culture. I have not the slightest doubt that Mr. Gray will overcome all the difficulties of soil, and the steps that he has already taken in this direction show clearly that he intends so to do.

The house is situated at the top of the hill facing the south; on the foot of it a fine Magnolia luxuriates (perhaps it will have to give way to a Rose by-and-by). It is now approached in a quiet sort of way from the high road down a series of stone steps, but among the alterations intended is that of making a carriage road from the far entrance of the grounds to the front of the house; indeed, it has been already begun. The ground slopes very steeply to the river Avon, on the banks of which is a level meadow, a portion of which I should never be surprised to hear had been absorbed by the Roses. It would be a nice cool place for late blooming. Inside of the house is a suitable museum, and in the dining-room is a grand collection of horns of buffaloes, deers, and other ruminants. All over the house are chests, closets, boxes, &c., which contain curios from all parts of the world; indeed, the owner once upon a time filled a town hall with his productions; he has books of photographs from countries (such as Borneo) very little known to Europeans, and altogether eyes and ears may have a real treat here, but these things must not and did not keep me from the main object of my visit, the Tea Rose growing.

Situated on a very steep declivity it was felt by Mr. Gray that it would be hopeless to grow Tea Roses or any Roses of any kind in such a position, as the soil would be immediately washed away; moreover, the soil was unsuitable and would have to be removed. The place altogether had been greatly neglected, and so strong measures were needed, and strong measures have been adopted, for Mr. Gray has made a series of broad terraces with stone walls. Some of these walls are 20 feet high, and it may readily be imagined what a work this has been. There are several of these terraces, and in the laying of them out only one thing has been taken into account, the Tea Rose and its requirements. The walls are all wired, and although I was told that Mr. Gray intended to grow fruit trees and Roses on them, I suspect very much that it is Roses and fruit trees, and that by-and-by the latter will be dropped. I have said that the soil is not a good Rose one, but there is every probability that it will be in a very short time all that the Roses require. I have said that there was plenty for eyes and ears, and so there is also for noses, for of all the loud smells that I ever happened to come across I think the whiffs one got in going through the garden could hold comparison with any. The seventy smells of Cologne, the delightful odours of a French country town, the abominations of Widnes were, I think, left behind in the race by especially one heap I passed. What could it contain? Oh! only brewers' grains, paring of horses' hoofs, of which he had laid in a ton weight, and sheep manure, the brewers' grains being possibly the most potent factor. Already he has put 400 tons of manure in his garden, and still the cry is for more. We were calling together at Alderman Chaffin's to see Mr. Taylor's wonderful Grape growing, and on his asking him what manure he used and being told it was cowdung, "Are

you offered more than you require?" "Oh! yes." "Well, then I wish you would put me in the way of a hundred loads of it." It may be thought that Mr. Gray is overdoing it in the matter of manure. I do not think so. There is a large space of ground to fill in, and the soil evidently will absorb a great deal of the richest material that can be placed in it. And now about the Roses themselves. Most of the trees (which are dwarfs) have been removed from Dunkeld, and are evidently rejoicing in the change; they all looked well and in good health. They were in many cases planted somewhat thickly, but that is only temporary, as they will have to be lifted in the autumn and planted permanently. On the terraces are large beds full of Tea Roses; on the walls and under the glass verandah are some of the seedlings he raised from the heps gathered in the Azores, but as yet nothing very remarkable has appeared amongst them. There was one very pretty buttonhole something in the way of William Allen Richardson, but very much smaller, that I thought very pretty. There were also single ones, but as yet nothing very worthy of notice has flowered. There are many more still to bloom, and it has always been found by raisers of seedling Roses that the most precocious are of very little use. Then in one corner we found a flourishing bush of Fortune's Yellow. Here again is a good promising row of Maréchal Niel standards promising well, while in another place a fine piece of budded Briars had to be sacrificed for the alterations. Mr. Gray evidently felt very much the heinousness of his sin in thus giving them up to destruction; but what could he do? Necessity has no laws, and there was a necessity for his doing this. You cannot turn anywhere in the garden but Tea Roses confront you.

Roses to right of them;  
Roses to left of them, &c.

like the guns at Balaclava. Already upwards of 2000 Teas have been planted; about 1500 more have been budded this year on Briar cuttings and the seedling Briar, and I have no doubt that these are but the advanced guard of more numerous battalions. It may readily be surmised, then, that some of our champion amateur Tea men are very considerably exercised about this prospective competitor, and there is no doubt that he will be a very formidable antagonist. There is one point on which their hopes considerably rest—that he will in such a situation be too early for the general run of exhibitions, and that his Teas will be over before the National holds its meeting. I should be sorry to dash their hopes, but I do not think that there is much comfort to be derived from this consideration. In the first place, while Bath is early as a rule, yet the situation of Beaulieu being high up, will, I think, make it somewhat later than many situations round the city, and as a matter of fact excellent Teas are those from Bath up to the middle of July; then, in the second place, the large number of plants, and the different positions in which they are to be found, will always be in his favour. It is here that big battalions carry weight; even the same variety of Rose shows a difference in the time of blooming, even in a short row of plants; and where so many aspects are available, there can never, in so large a collection, be a deficiency of bloom. And then, thirdly, there is the consideration of pruning. By judiciously varying the time of pruning, the flowering may be accelerated or retarded, and Mr. Gray is too wary a grower not to take advantage of this. He has not as yet decided whether he shall enter the lists or not next year, but should he do so, all Tea growers will find in him a very formidable competitor.

I have thus endeavoured to give an idea of what I cannot but consider the most remarkable Rose garden in the kingdom. It is now in a state of transition, but when Mr. Gray's work is complete, and when his army of labourers (there were twenty-one at work there the day I saw it), have been paid off, I venture to believe it will be a unique Rose garden. I know most of those in the kingdom, but I may fearlessly say that there is not one like this.

When the night closed in and we had a quiet chat together, many subjects connected with the Rose and Rose showing were touched upon. On some we agreed, and on others we differed. There was one point of interest that he was very persistent about—viz., that the judges should, in the principal classes when awarding the prize, also place on the card the number of points it had received, for the benefit of learners. It was in vain I pointed out to him the trouble and the difficulty of doing it in time, or the fact that some judges would take a higher standard than others, and that unless each Rose were marked, no great advantage would be reaped. He returned to the charge, and so I promised that I would bring it before the public. He did not want it, he said, so as to make it appear that judges had to give reasons for their adjudication, but for the purpose of teaching others.

I need hardly say that I received a most kind and courteous reception, and I am quite sure that when Mr. Gray has got his place into order he will welcome all true lovers of the Rose, and be glad to have a chat with them over the flower they love, not only wisely, but well.—D., Deal.

### VINE BORDERS AND UNORTHODOX PRUNING.

"EXPERIENTIA DOCET" asks, page 133, "What is the subject in dispute?" and answers the question by the refreshing statement that where the spur system of pruning produces satisfactory Grapes no one will be urged to change his plan of action. "It may be right for one class of Vines, and it is right, but it is utterly wrong for others." "What reasonable man," further queries "Experientia docet," "can object to that, except for the sake of controversy and argument?"

Who objects? I went so far in the opposite direction as to assist him with evidence, helping him forward. What more could any reasonable man desire? Seemingly it is not enough to satisfy "Experientia docet," hence the re-opening of the whole question, in view, no doubt, of another review.

To introduce the statement into a discussion on Vines of their being "no more naturally adapted to the spur system of pruning than Peaches are," can have no other effect than to provoke controversy and argument. The Vine never forms spurs naturally or culturally, but the Peach left to Nature produces its fruit mainly on spurs. Comparisons of that kind are very unorthodox. Then we are asked to believe that "a modified extension system of pruning would result in far better crops of Grapes than some Vines can possibly bear when the bearing wood is cut off close to the main rods." Who would expect Grapes when the bearing wood is cut off? The practice if it obtain is clearly unorthodox, and "modified extension" is simply the orthodox rod disnise!

The Cole Orton Grapes prove conclusively the great advantages of the orthodox rod system of pruning in securing gold medals, fed as the Vines were with the right food, in proper quantity at the right time. This with a properly made border, the roots being confined to a brick pit, therefore, perfectly under control, and high cultivation, led to the winning of £300 in prizes. Who would slight such proofs of high cultural attainments?

"Modified extension," "Experientia docet" states, I condemn on page 326. Manifestly our friend stumbles or makes the final plunge in despair, for I confess to not knowing what "modified extension," as he employs it, means. Perhaps it is the "long-pruning," marked the "no system or no principle, yet principle of pruning to the best buds, let them be situated where they may," that only being granted for the guidance of the unorthodox seekers of Grapes. "Modified extension" is clearly a departure from long-pruning, a move backward, all the same in the right direction—viz., toward the short rod and spur.

I have never stated that an extension of young canes leads to unsatisfactory results, except when the roots are in an unfavourable rooting medium, and to that I adhere. I believe in a favourable soil for the rooting of the Vines, and unless that is accorded no satisfactory results can attend any system of pruning, and cultural skill on such is misplaced. Properly made borders lie at the root of all successful Grape culture, and to state otherwise is misleading. Not that costly borders are necessary, for the Vine is not at all fastidious, only it likes good pasturage which any ordinary garden soil affords, or may afford by adding suitable material and feeding at the surface.

"Experientia docet" is at a loss to know where I got the information from anent the old Vines at Cole Orton. If they were all right, why did Mr. Henderson make a departure from the spur system and adopt the rod? It does not require any great insight in Grape cultivation to become aware of such obvious facts.

"Experientia docet's" explanation of "orthodox nonsense" is characteristic of his indebtedness to an opponent for facts as well for subject of controversy. Your correspondent is welcome to all the consolation he can derive from what I have written about Vines, even the Chiswick Vines, if it suits his purpose to make me the author of the term "modified extension system," which I take to in anticipation with a profound bow, as I claim for the Grape cultivation as it obtains in the great vinery, every good system and principle of orthodox Vine pruning—viz., the spur, the short rod, and long rod, and not on individual and peculiar Vines only, but all, in some instances on the same Vine, so that there is no question of the soundness of any of the systems. How anyone can claim any system of Vine pruning as unorthodox is not nigh, but quite "incomprehensible."

Now for the "turn round." Your astute correspondent asks why I should turn round on myself. The fact is, it is "Experientia docet" that has turned round. Long pruning was advised as a cure for Vines that from weakness or excess of vigour did not produce satisfactory crops of Grapes, the roots not being under control, indeed nothing could be done to better the condition of the rooting area. The only instance of a cure of this kind is given by myself, for "Experientia docet's" was a case of border renovation, and though the one Vine, perhaps a hundred years old, had the roots straight down, quite below the bed of the new border, we may safely infer that it would push fresh rootlets into the fresh material and so be benefited by the fresh compost. That is all the evidence, so far, in respect of keeping Grapes by long pruning where the roots were not under control. In Mr. Henderson's case they were not only under control, but well fed and skilfully managed. The same obtained with those in the great vinery at Chiswick, Mr. Barron being a great advocate of surface roots, of proper and judicious feeding. At The Firs, Mr. Sanders not only let the Vines extend, but applied lime, fresh soil, and manure, and these your correspondent admits had some effect, but the chief cause of the improved condition of the Vines and crop was the long pruning. The lime, fresh soil, and manure are so little accounted of, that they are all but left out in the cold. To take credit for long pruning alone we must ask for it where the roots of the Vines are not under control, otherwise how are the results to be estimated?

What does "Experientia docet" think of the figure and description of the Manresa Vine? If evidence is wanted of the virtue of the spur it is placed before him incontestably—his long pruning has never figured so conspicuously. But letting that pass, allow me to ask upon what "Experientia docet" relies for the production of Grapes? The bud? If so, what does it signify whether it be the first, second, or third from the

base of the current or preceding year's development? Now, a bud can only be a bud. Are those best on shoots that do not carry fruit? I have Vines with canes over 20 feet long, others of 6 to 12 feet, and I wish to know how I am to tell the best eyes on those rods, so as to cut back to a safe one at the autumn or winter pruning. It seems to me strange that we should encourage young canes, and for the sake of cutting them off at the winter pruning. The wood removed represents so much matter taken from the soil and wasted when cut away. The whole bud question is very little understood, anyway I know very little about it in so far as regards bud formation. The most I know is that it is a most interesting and instructive study. Can anyone tell me how to distinguish the best bud or buds on the 20 feet, 12 feet, and 6 feet canes? If no one comes forward with a satisfactory reply to those lengths of cane, perhaps they may tell me the best eyes to be found on the shoots that are stopped a few joints beyond the fruit. I may say that I have Vine shoots stopped at the second joint, and should very much like to know which of those buds on the laterals are best from a fruiting point of view. Either there is or is not a proper bud to cut to in order to have the best show of Grapes. The unorthodox state there is a best bud, but it is "anywhere;" but I am orthodox enough to believe there is nothing without cause, and only guidance is needed to find it.—G. ABBEY.

#### SEEDING AND GROWING PRIMULA OBCONICA.

MY plants were flowering with their wonted freedom, and strangely enough, so long as I allowed them to develop flowers, the older flowers would not set for seed, despite any would-be assistance with camel-hair brush. Some weeks ago, after puzzling myself as to the cause, I decided to pick off all new flower spikes as they emerged from the tufts of leaves. This I followed up rigidly for some time, with the result that I had an abundance of seed pods form, which gave a splendid lot of seed. I mention this since this Primula seems to be fast gaining the name of being a shy and uncertain seeder. Those plants which produced the earliest batch of seed are now ready for dividing. A fortnight or so since I cut off all the flower stems, so that the plants have had a slight rest, and fresh leaves are now pushing forth. To make the most of so useful a plant I treat them thus:—First shake off all the soil and lay the roots bare by washing them in a pail of water; this enables the operator to trace how best he can divide his plant, and he will also find in the majority of cases that the plants will readily divide into single crowns, each having roots attached. Pot these singly in 2½-inch pots, place them in a frame, or where they will be kept close and shaded for a time. When they are fairly started let their treatment be exactly that given to Chinese Primulas both as to soil and other particulars, differing only by keeping all the flowers pinched off *P. obconica* as they appear until they have obtained a good size. They will be ready for flowering early in December, and flower spikes will continue increasing in number as the days lengthen. This is a veritable gem for the conservatory and for winter flowering, and certainly no other species in this extensive genus can equal its perpetual flowering qualities.—J. H. E.

#### TOMATOES OUT OF DOORS.

THE extensive walled-in kitchen gardens and ranges of glass houses attached to Hampton Court Palace, occupied and cultivated by Messrs. T. Jackson & Sons, of Kingston-on-Thames, are at all times interesting, not only on account of the historical associations and the excellent ranges of fruit houses, in which are growing splendid examples of Black Hamburgh and other varieties of Grapes (the former, no doubt, offsprings of the celebrated Vine in the neighbouring house at the Court); but especially so at the present time on account of the very successful crop of Tomatoes growing out of doors. The weather has been favourable; but allowing for that, this is the heaviest crop of Tomatoes I have ever seen growing in the open air in any part of England. No doubt the preparation of the plants in spring before planting out is the secret of success in the out-of-door cultivation of Tomatoes, and the want of attention to this the cause of many failures; but here is a plain proof, if proof were required, that given a favourable season they can be grown better than most people imagine. There are two plots in the enclosed gardens, one containing about 900 plants and the other about 400. They are planted about a yard apart, each tied to a stake, and it is estimated that between 3 and 4 tons of fruit will be gathered from them. The plants are bowed down with fruit in clusters of from twelve to twenty in number, and loaded from top to bottom. The most approved sort, on account of the earliness, although it is not the largest, is Sutton's Earliest of All. It is evidently a selection from Orangefield Dwarf; from these ripe fruit have been picked for six weeks past. Another is Hampton Court Trophy, a selection of Mr. Latham's (the manager), who has grown it for the past six years. It is a very fine and free variety, growing about 4 feet high, and certainly an improvement on the old variety growing by its side. Sutton's Perfection is a very distinct and clean-looking fruit; this grows about 5 feet high. The Mikado is another variety on trial. It is a fine large-fruited variety, but evidently too late for out-of-door cultivation. Optimist, although now carrying heavy crops, evidently in ordinary seasons would be more fitted for indoor work. The plants are wonderfully clean and healthy, and in common with the other growing crops reflect great credit on Mr. Latham.—C. O.

#### THE SEASON AND CROPS IN EAST LOTHIAN.

SOME remarks on the season and crops from East Lothian may be of interest at the present time. It may be premised that the rainfall here



has been practically nil. We have heard the rumblings of thunder in the distance, and seen dark clouds away above the hills discharging their contents on the parched land, but somehow our particular corner has never been visited with other than showers insufficient in amount to penetrate further than the dry surface soil. So trying has been the drought that shrubs planted for nearly twenty years have had water applied to their roots in order to tide them over the worst period. Still, so far as the garden and its products are concerned, we have had slight cause to grumble.

Taking vegetables first, we have had difficulties with Spinach, Lettuces, and Cauliflowers, while Globe Artichokes are the poorest crop we have ever had. Still, we have always had a supply of each of these. More Cabbage Lettuces have been grown than usual, and these have been a great help. In the hottest of the weather Spinach was sown in the trenches in which early Peas had been grown, and with the help afforded by a dressing of Mushroom-bed refuse and a good sousing of water a fair crop resulted. We depend greatly on the Erfurt Mammoth Cauliflower, and although much damaged by the drought, no water having been given, even the very smallest plants produced heads which were presentable and of value. Of other vegetables the most important are Potatoes and Peas. Potatoes have been much better than last year, Myatt's, though not a great crop, being of good size and excellent as to quality. White Dons are very fine with us, flesh of purest white and of the finest flavour. Some of the newer kinds are attaining ripeness, but as yet we have not had an opportunity of trying these.

Of Peas we had William the First, very fine. Stratagem was fairly good, but too sweet; Telephone not so good; Veitch's Perfection, a big crop and excellent; and Ne Plus Ultra has been, and now is, extra fine. None of our Peas approach this in flavour, and, of course, as a late kind it is indispensable. These have been produced without watering, and are all sown deeply in trenches. French Beans, though later, are fine, Onions and Carrots better than last year, Celery smaller than usual. Brussels Sprouts—the earliest of which are ready—are very strong, though planted on undug ground. Nonpareil Cabbages have been fine all through, and we have now a good batch ready for cutting. Turnips have been better lately than the earliest lots were. Autumn Giant Cauliflower has been a failure so far as the earlier plants are concerned; the others are later than usual. Early Broccolis are strong and looking well. All our late sown seeds have braided well, the precaution having been taken to sow deeply, and previous to putting in the seeds soaking the rows with water. The main batch of winter Spinach is just through the ground. It is much better to sow in August than wait till September, as many of the late plants do not gain strength before winter.

As to the fruit crops, Strawberries and Raspberries were most disappointing. Other crops have, however, exceeded the expectations formed of them, having improved wonderfully during the last week or two. The fruits named above showed exceedingly well, and yielded two fairly good pickings, but in the case of each the fruit seemed to stop growth as it were, at a day's notice. Neither mulching nor watering seemed to have any effect in this district, as the complaint of a short season has been quite general. President Strawberry was particularly fine while it lasted, other sorts not so good as usual. Runners have been so poor, that instead of planting out into the permanent fruiting quarters, we have been obliged to lay them in nursery lines and protect them with mats until established. It may be noted here, as the question has been mooted, that we have not found Loxford Hall Seedling adapted to our garden. During the time it was grown here we never saw one ripened fruit, and concluded that, like Dr. Hogg and some others, it could not be cultivated in every garden with success. In my experience with new Strawberries I have found them disappointing.

Pears are next to the above the least satisfactory, the crop of blossom was less abundant than usual, and the fruit is not swelling to so large a size as in some seasons. However, on the whole the crop is fairly good, Williams' Bon Chrétien, Souvenir du Congrès, Winter Nelis, Easter Beurré, and some others being good crops, and have required a good deal of thinning. Standard trees set an enormous crop, and trees of Williams, Green Yair, Hesse, &c., are now all that can be desired. Plums were rather uneven as to bloom, but there are fair crops on all, and on some trees quite enormous quantities of fruit set. On all these the fruit was well thinned at an early stage, and we have now fruit of most excellent quality. Jefferson and Green Gages were never finer. The kitchen Plums are this season of dessert quality, Kirke's Purple being especially good.

Apricots, as they have for the last few years, set extraordinary crops, the spurs and shoots being covered closely all round. We thinned early and severely, and have a large crop of fruit not quite so large as usual, but of very fine quality. On the 22nd of August we made the fourth general picking, the first having been made three weeks earlier. We have not pinched in the young growths this summer, but will do so when the fruit is all off, so that there may be no fear of the flower buds being healthy next season. The border in which these trees are growing is to all appearance perfectly dry, yet the trees are making good growth, and, as already stated, have done well. The kind I like best is Shipley, the fruit being large and of good flavour, and the tree making a rapid growth. Kaisha is also an excellent sort, quick in growth, the fruit large, easily ripened, and the flavour fair. D'Alsace proves very rich in flavour, and I think will prove a useful kind. Moor Park is, of course, as to size and flavour the most excellent, but with us the tree grows very little, and even in the case of quite young trees there is much loss through the branches dying. Peach has the same fault.

This has been a most interesting season so far as Apples are con-

cerned. The trees bloomed well, but during the time the flowers were open the weather was cold, dry, and comparatively sunless. The set of fruit was, in consequence, not so large as the show of blossom would have led one to expect; still, there was sufficient to ensure a good crop throughout, and with some kinds the crop set was very large, causing a good deal of labour in thinning. Ecklinville and Warner's King are examples, which set a sufficient crop and no more. Duchess of Oldenburg, Keswick Codlin, Lord Suffield, and Rymer set extraordinary crops. Outstanding features with Apples this year are the good shape and fine colour of the individual fruits. Warner's King has been much larger, but never so well shaped, and never before coloured as it is this year. Lord Suffield is this season quite free from blemish and the exposed portions slightly coloured. Some of the Ecklinvilles are beautifully coloured, while Duchess of Oldenburg, Red Astrachan, Cox's Pomona, Reinette du Canada, Mère de Menage, Cellini, Manx Codlin, Ribston Pippin, and others are more like fruit grown in the south than we have ever seen them. The following are larger than is usually the case—Ribston Pippin, Court of Wick, Cox's Orange, Duchess of Oldenburg, Blenheim Orange, Wellington, on old trees; Manx Codlin, Hawthornden, and Hormead Pearmain. The following are the average size, but of a finer quality—Early Julien, Lord Suffield, Ecklinville, Northern Greening, Cellini, Red Astrachan, Margil, Cox's Pomona, King of Pippin, Old English Codlin, Claygate Pearmain, Mère de Menage, Kentish Fillbasket, Tower of Glamis, Alfriston, and Irish Peach. These are smaller—Devonshire Quarrenden, Wellington, young trees; Warner's King, Stirling Castle, Keswick Codlin, Rymer, Reinette de Canada, Margaret, Yellow Ingestrie, Cobham, Downton Pippin, Coekle Pippin, Kerry Pippin, Early Harvest, Fearn's Pippin, Bedfordshire Foundling, and Court Pendu Plat. The above are some of the more popular kinds. Of newer sorts on trial we have not seen enough of yet to risk an opinion. It is perhaps necessary to state that trees requiring to be thinned of fruit on account of too thick a set were so thinned at an early stage. Our trees have not been watered, but they are all in deeply cultivated ground, and those from ten years old downwards are regularly attended to at the roots. The few Peach trees grown out of doors have done very well, but our one solitary example of the Fig not so well as usual. Bush fruit carry very big crops. Another opportunity must be taken to refer to flowers.—B.

#### AROUND NEWCASTLE-ON-TYNE.

GARDENERS travelling northwards this year will find Newcastle a convenient centre for visiting a number of good gardens, and so many horticultural visitors have been attracted by the Jubilee Exhibition this week that a few hints as to what is especially worth seeing in the district may prove useful to those unacquainted with this part of England. There is a combination of attractions in the present season, for the general exhibition, opened in the spring and to be continued until October, possesses much interest, and the attendance of visitors has been very large; it was therefore a good idea on the part of the Committee of the leading Horticultural Society in the north of England to make a special effort in rendering their autumn show worthy of the Jubilee year. They were fortunately met in a good spirit by the Council of the other exhibition, and sufficiently liberal terms were obtained to induce the Horticultural Society to hold their Show in the exhibition grounds, and as a part of the attractions provided for the public. This alone added to the importance of the Show, and a very liberal schedule having been compiled, much attention was attracted to the Society's effort to obtain a creditable exhibition, and Newcastle became the centre of horticultural interest for the present year.

Entering the great coal city from the south does not give a good impression to the stranger who is desirous of seeing picturesque gardens and examples of the best culture; and striking as is the first view obtained from the high level bridge in crossing from Gateshead to Newcastle, it does not give the slightest indication of the natural beauty of the surroundings, nor even of the architectural beauty of the chief streets in the city itself. The Tyne is seen far below with its quays and shipping, the steep banks on each side being covered with factories, warehouses, or dwellings, in the construction of which utility has been the chief object studied. There is also a sufficient quantity of smoke to cause an unpleasant obscurity even in bright sunny weather. It is, however, a remarkable scene, full of interest to the observer as representing a mighty industry. But in another respect of more importance to horticulturists Newcastle is remarkable—namely, in the number and varied character of its parks. In these it is unequalled by any provincial town, and London itself cannot claim all the honours, extensive and well-kept as are "the lungs" of the metropolis. It is strange, too, that until within the past fifteen years Newcastle was unprovided with public parks or gardens of any kind; it was, indeed, inferior in that matter to the neighbouring town of Sunderland, which had been provided with a park for nearly twenty years before the importance of such places of public resort was recognised in Newcastle. Very much of the improvement effected within recent years is due to the liberality of Sir William (now Lord) Armstrong, who has presented the city with the greater portion of the land employed for the purpose, and still maintains at his own expense the most picturesque of them all. Newcastle owes a considerable part of its importance to this gentleman, whose wonderful foundries at Elswick employ from 10,000 to 15,000 men constantly, and his endeavour has always been to improve the city with which he has been so long connected. Well merited indeed was the honour recently bestowed upon him, and at his beautiful Cragside estate in the heart of

Northumberland he now enjoys some of the relief from business so amply earned.

#### ARMSTRONG PARK.

To commence a tour of the parks the most convenient plan is to proceed in a Byker tramcar, starting from the Central Station to Cook Street, and a short walk from that point conveys the visitor to the entrance of the first of a series of three parks which extend for several miles. One portion of the first reached was called the Heaton Park at one time, and is still called the Heaton section. It was formerly the property of Colonel Addison Potter, whose residence, Heaton Hall, still stands near to it in greatly restricted grounds. It was purchased by the Corporation, and another portion given by Sir William Armstrong was incorporated with it, both now passing under the name of the Armstrong Park. There are about fifty acres enclosed, but owing to the varied character of the ground and its situation in a long narrow well wooded valley, with considerable elevations commanding views of neighbouring estates, it appears much larger than it really is. Entering from Cook Street the principal road passes along an elevated portion of the Park, with deep slopes on one side covered with Ferns growing luxuriantly, and clothed with trees, Beech, Elders, Maples, and Horse Chestnuts predominating. There is a succession of hills and dales, open glades of turf, and pretty views in the direction of hills on the other side of the deep valley crowned with trees, and here and there a few villas peeping out. Several of the higher slopes are utilised as rockeries occupied with numerous alpine and other suitable plants, which appear to thrive excellently. The road descends somewhat, passing through a dense belt of trees, and the principal flower garden, with its admirably kept bowling greens and croquet lawns, which are quite a feature in all the Newcastle parks, as well those of some other north country towns. These lawns are surrounded by grass slopes, in which are beds devoted to miscellaneous flowering plants. Those of a popular character distinguished by their fragrance, rich colours, or long continuance of flowering—Mignonette, Violas, and Roses—are largely grown, also mixed beds of Pelargoniums, Petunias, Pansies, Lobelias, Phlox Drummondii, Asters, and Zinnias. Some fine mixed beds of Stocks, Ageratums, and Roses have a capital effect edged with Dell's Crimson Beet and *Dactylis glomerata variegata*. At the upper portion is a terrace which affords an agreeable promenade, commanding a view of the lawns and flower garden, and some beds at the lower portion of this are planted with the ordinary bedding plants on a broad ground of *Cerastium tomentosum*, the taller Castor Oil Plants, Chilean Beet, Palms, &c., forming the background. Upon the terrace are aviaries and several glass houses, one being chiefly devoted to flowering plants, and another to Ferns placed on a tastefully designed rockery. These are not open to the public, but as they are of moderate size with glass sides and doors their principal occupants are readily seen from the outside.

The other portion of the park, which is reached shortly after leaving these houses, contains some high grounds, surmounted by an old ruin at one part and by a windmill at another, both sites commanding fine views of Newcastle, with the delightfully wooded valley leading to Jesmond Dene. Several picturesque features are introduced here, little bridges having small rivulets or dells, with dense shrubberies at the sides and mixed beds of *Calecolarias*, *Pelargonium*, and miscellaneous flowering plants. Full advantage has been taken of the situation and its natural beauty, and though it cannot be compared in the latter respect with the adjoining Jesmond Dene, it still possesses attractions of no mean order. It is kept in first rate condition by Mr. A. Theaker, who has now been in charge for eight years, and a good portion was laid out or planted under his superintendence.

#### JESMOND DENE.

The valley already mentioned appears to deepen and contract past the point where it is crossed by a graceful iron bridge at a great height, and this forms the boundary between the Armstrong Park and the remarkable Dene, which for over a mile presents a succession of picturesque scenery and luxuriant vegetation such as cannot be seen in any other town in Great Britain. It is worth a long journey to see, and it is surprising that its beauties are so little known, for many a lesson in natural landscape gardening could be derived from an inspection of this Dene. It was the property of Sir William Armstrong, and still remains under his control, being maintained entirely at his own expense, though thrown open to the public the same as the other parks, and it is expected that ultimately it will be transferred to the Corporation. Valleys of this character are frequent in Durham and Northumberland, but when treating them artificially with a view to their improvement, it becomes very difficult to avoid introducing some incongruity which might spoil the whole effect. The plants employed, and the manner in which they are disposed, have to be carefully considered, and it is almost unnecessary to say that Lord and Lady Armstrong, both of whom are distinguished by their excellent taste, have given these matters their serious thought. The result is an example of how far Art may be advantageously employed to improve Nature, for there is not one jarring element in the whole Dene. The exotic plants employed are those that grow with sufficient freedom to render them thoroughly at home under their new conditions, and instead of being dotted about singly or in two's or three's, we see masses of several square yards, banks covered with particular plants, jungle-like masses of others in the damp portions of the ground, and a natural luxuriance of vegetation throughout that is delightful in the extreme.

The chief features that arrest attention when entering the Dene from

the Heaton Bridge end are the masses of Furze, Heaths, Funkias, and *Spiræa filipendula* clothing the banks both to the right and left of the winding path, which in some parts descends gradually towards the rivulet or burn at the bottom of the valley, and then rises far above it. The right hand bank is very steep, and in several places probably exceeds 100 feet in height, the left bank sloping downwards, and upon both there is a dense clothing of trees, those on the ascending bank being the largest; they comprise Sycamores, Purple Beech, the Mountain Ash loaded with its scarlet fruits, with numerous shrubs, such as *Mahonia aquifolia*, and small trees as undergrowth. Large patches of *Helianthemums*, in steep sandy places, have a capital appearance. Pinks also look well in similar quantity. *Oenotheras* in variety, Irises, and the brilliant *Lilium chalcedonicum* flourish as many an owner of a hardy plant garden would wish to see his own pets do. For a long distance the steeper banks are thickly covered with *Vinca minor*, which, overshadowed by trees that also partly overhang the path, grows vigorously and forms a dark green clothing as close as if it were clipped. Extensive patches of *Megaseas* are telling amongst the smaller leaved plants, while large clumps of *Polygonum eupsidatum*, succeeding as that plant always does in a damp situation, impart quite a sub-tropical appearance to some portions of the Dene: *Campanulas*, *Liliums*, *Saxifragas*, and scores of other hardy plants are employed in profusion; in every instance they are in colonies of one kind, not kept within formal bounds, but allowed to increase at will.

The path descends beneath an arch and emerges near the stream amidst rich vegetation, the extremely high bank on the right being here chiefly occupied with Thorns, Maples, Sycamores, Elders, *Rhododendrons*, and Ferns, while on the left are some open glade-like turf slopes, where *Cupressus Lawsoniana* is represented by a group of fine specimens, and nearer still to the water, but especially where it is crossed by a small bridge overgrown with Ivy, is quite a forest of the Giant Bulrush, with masses of *Epilobium angustifolium* flowering profusely, Golden Yews at the side, Austrian Pines and a magnificent forest-like bank of trees on the opposite side. The view from this point is exquisitely beautiful, an artistic study, every part in harmony with the surroundings, and abounding in delicious vistas. This varied though quiet scenery continues for a good distance, but towards the upper part of the Dene there is a change in the character; the waterway becomes deeper and rocky, the water falling over a high rocky shelf-like plateau into a course filled with huge masses of stone, where it dashes along rapidly into the smoother course below. A substantial handsome bridge spans the water at this point, and, as shown in the woodcut (fig. 25), prepared from a photograph of this scene, it has a highly picturesque appearance. The lower path is cut through or over the solid rock, but there are several paths conducting to the higher portions of the right bank where a prospect of exceptional beauty can be obtained. It is difficult to do bare justice to this charming Dene, for when seen on a fine summer's day, with the foliage of trees and shrubs fresh, as it might be expected to be in such a sheltered valley, and flowers abundant in every direction, it could scarcely be rivalled. As a public park it is unique, for in few places are so many natural advantages afforded, so much taste displayed in developing them. We understand that Lord Armstrong takes a personal interest in the superintendence of this park, but entrusts the practical charge to Mr. Wilson.

Quitting the park at the upper end and bearing to the left we approach several imposing residences, amongst them being Lord Armstrong's private garden, which is also termed Jesmond Dene. This is an extremely interesting garden, containing a large number of glass houses, where both fruit and flowers are well grown, the latter in large numbers. We cannot refer in detail to this garden in the present issue, as it deserves a more lengthened notice than space would admit this week, for the practical care of the courteous gardener, Mr. Elliott, is evidenced in all departments.

#### LEAZES PARK.

Proceeding on a tour of the parks Osborne Road is readily reached after leaving Jesmond Dene, and thence a tram runs to the Grey Monument, opposite Blakett Street. Ten minutes walk through that and Albion Street conduces to the Castle Leazes, an open moor-like space, and to Leazes Park. This is about thirty-five acres in extent, and was the first taken over by the town as a public park. Though comparatively small it has been laid out effectively, and is well furnished with trees and shrubs, which with an undulating surface serve to conceal the real extent of the place. *Laburnums*, *Ligustrums*, *Aucubas*, *Poplars*, *Willows*, *Maples*, *Mountain Ash*, *Elders*, *Rhododendrons*, *Lilacs*, and the common *Laurels* thrive much better than might be expected, for the park is much more exposed to the smoke from the factories on the Tyne than those already noted. They are planted in dense masses, and with a few Copper Beech introduced at suitable intervals have a bold appearance. A lake and rock-margined island are seen in one portion, the usual bowling and croquet lawns admirably kept are found in another, and at the highest portion of the ground is a terrace which overlooks the park and also commands a view of the town beyond. Numerous flower beds are there provided, Zonal *Pelargoniums* constituting the chief feature, with a few neat carpet beds, *Dahlias* and *Rhododendrons* in the background. There some fine banks of the Golden Elder, very rich in colour, and numerous mixed borders, *Stocks*, *Pansies*, *Epilobiums*, and *Golden Rod* being conspicuous at the present time. This park is under the charge of Mr. John Wilson, and its condition is creditable to the care it receives.

#### ELSWICK PARK.

A short walk by way of Diana Street and Elswick Road brings us to



the smallest of the Newcastle Parks, the Elswick or West End Park which consists of twenty acres, formerly the grounds attached to Elswick Hall, a substantial old mansion, now employed as a museum for models of the works of the late John Graham Lough, a Northumberland sculptor of considerable eminence. The park derives its chief interest from the steep slope of the ground from the Elswick Road to Westmoreland Road, affording an extensive view of the Tyne valley and the hills on the opposite side. It has also permitted a picturesque arrangement in a series of terraces or plateaux, the upper being devoted to lawns and bowling greens, surrounded by flower beds and shrubberies, but still more difficulty is experienced in keeping the trees in good condition, as the smoke at times comes up from the valley in overwhelming quantity. The terrace and slope in front of the Hall is well kept, and contains a

## HORTICULTURAL SHOWS.

HALLAMSHIRE FLORAL AND HORTICULTURAL SOCIETY.

AUGUST 22ND.

THE twentieth annual Exhibition of this Society was held in a large field at Ranmoor, near Sheffield, kindly lent for the purpose by C. H. Firth, Esq.; and in addition to the attractions provided by the Show and its accessories, the whole of the beautiful grounds and conservatories belonging to Mrs. Mark Firth at Oakbrook were thrown open to those visiting the Show, and both these and the Show tents and grounds were during the late afternoon and evening thronged by crowds of admiring people. The Show was quite equal as a whole, and in some respects superior in merit to those of preceding years. Two large tents were well filled with the exhibits, and considerable praise is due to the Curators for the very excel-

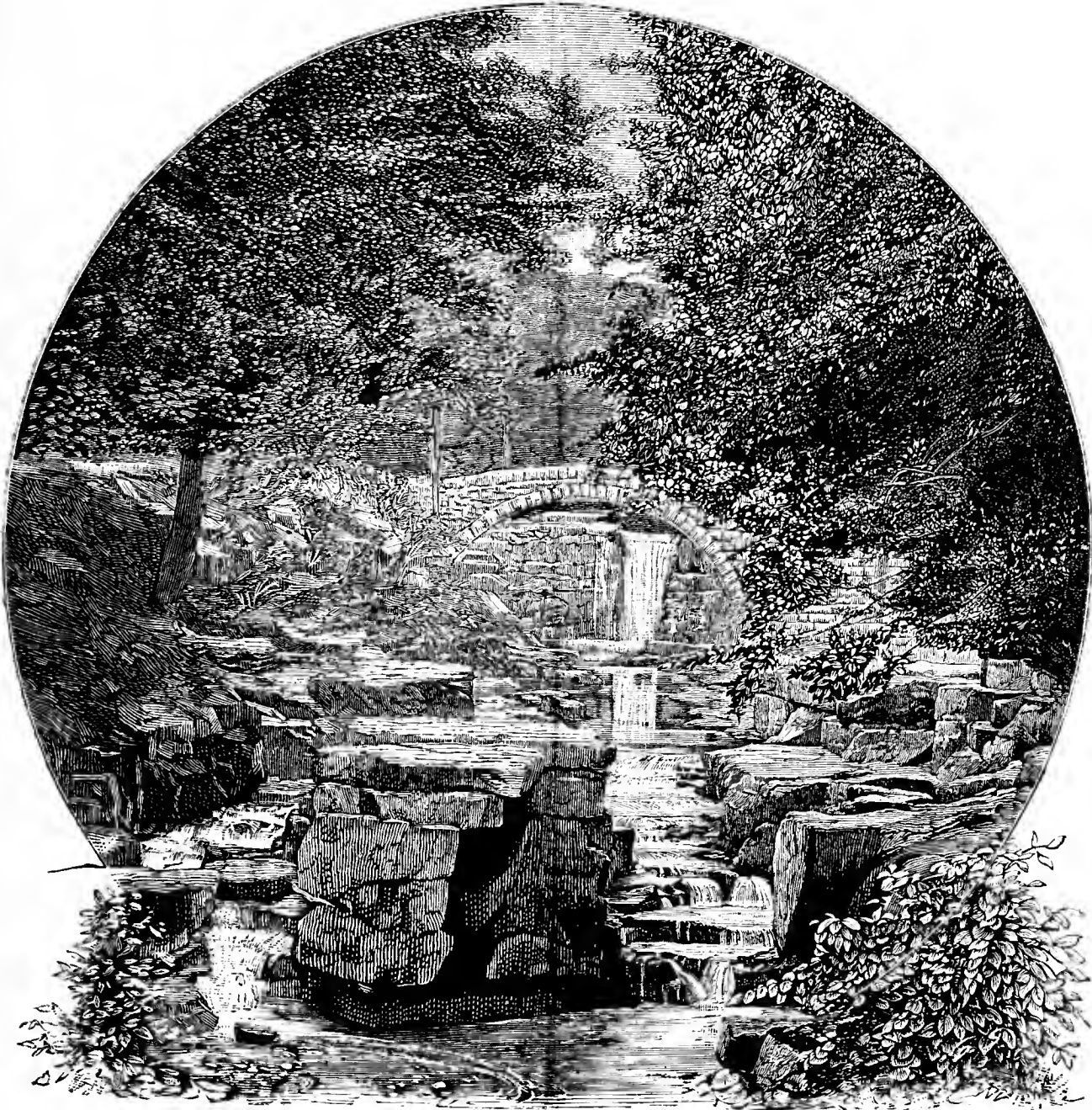

Fig. 23.—JESMOND DENE.

number of very bright flower beds, Pelargoniums, Calceolarias, Asters, Marigolds, Lobelias, and Ageratums being the principal plants employed, a bold ribbon border of a crimson Godetia and Tagetes signata pumila in bold bands having a striking effect. A small lake, partly concealed amongst the trees, completes the features of this pretty little park.

The Town Moor is an extensive open space, not specially attended as a park, but employed as a playground or for meetings, while in Gateshead a small but pretty little park has been recently opened under the name of the Saltwell Park, from which a pleasing view can be obtained across the Team valley to the wooded slopes that partially conceal Ravensworth Castle. In the neighbourhood of this park are several gentlemen's residences and gardens, one of the principal being Heathfield House, occupied by Theodore Lange, Esq., and concerning which we hope to say more on another occasion.—LEWIS CASTLE.

lent manner in which they were arranged. The principal tent, devoted to the classes open to all England and to the gentlemen's gardeners' class, was very beautiful. A great improvement had been effected by dispensing with the tables and stages up the centre, and grouping the specimen plants instead upon the ground (grass). Side tables were still used as before for the exhibits of cut flowers, fruit, and vegetables, and for this purpose only, we think, should tabling be allowed at these shows.

At the entrance to this tent was a charming group of plants not for competition by Messrs. Fisher, Son & Sibray, Handsworth Nurseries, containing some excellent plants of *Ficus elastica variegata*, *Lilium*, *Ixora*, *Dracenas*, *Bouvardias*, *Eulalias*, and *Adiantums*. A plant in this group which attracted much attention and curiosity was a well bloomed specimen of *Rochea falcata*, a beautiful succulent which deserves to be much more widely known and grown than it is at present. In the class for six stove and greenhouse plants, flowering and foliage, there was a very strong



competition, and the first-prize specimens exhibited by Mr. Thos. Shelley, gardener to Mrs. Hobson, Burnt Stones, were in every way first-class, and such as would have gained for the exhibitor an honourable position in the best shows in London or the provinces. They consisted of *Dipladenia Brearleyana*, a grand specimen 4 feet high and 3 feet in diameter, covered with large and highly coloured blooms; *Miltonia spectabilis*, 3 feet 6 inches in diameter, solid with bloom, and an exceptionally good variety; *Ixora Williamsi*, a large plant, the foliage quite hidden by a mass of flowers; *Stephanotis floribunda* and *Eucharis amazonica*, both large and finely bloomed; and a good specimen of *Alcascia metallica*. We do not remember to have previously witnessed six plants of such sterling merit throughout exhibited in Sheffield. The second-prize six exhibited by Mr. Sheridan, gardener to G. Howson, Esq., were of very high quality, and contained a grandly bloomed specimen of *Bougainvillea glabra*, also the old favourite *Plumbago capensis* finely represented. In the third-prize lot were some good plants, notably *Hoya carnososa* covered with its beautiful trusses, but the colour is not effective in an exhibition. Specimen Ferns, both exotic and British, were, as is usual at these Shows, both numerous and good. In both classes Mr. Shelley was the first-prize winner. The six exotics included grand examples of *Davallia Mooreana*, *Pteris scaberula*, and *Adiantum cuneatum*.

Fruit as a whole was very well exhibited; in hardy fruits especially the entries were very numerous, and the quality throughout good. Grapes were not superior, excepting one entry of two bunches of Muscat of Alexandria by Mr. Page, gardener to D. Ward, Esq., than which finer have seldom been shown anywhere or at any time.

Vegetables were very fine almost throughout, the main exceptions being Cauliflowers and Peas. Potatoes, Celery, Onions, Beans, Cucumbers, and Marrows we have never seen better. The first-named, especially, were shown in great numbers, and were wonderfully fine throughout.

A large number of Roses were shown, but with the exception of the exhibits not for competition by trade growers were not of very high quality. Messrs. Fisher, Son & Sibray had three large boxes of really good blooms, and Mr. Duncan Gilmour added very greatly indeed to the attractiveness of the Show by staging in his usual first-class style upwards of 1000 blooms.

Dahlias were finely shown in the amateur and cottager classes, Mr. Charles Storey and Mr. S. Moore dividing the honours fairly equally between them with grandly finished blooms. The exhibits throughout in these classes of plants, cut flowers, fruit, and vegetables were of excellent quality, the cut flowers and vegetables especially being scarcely inferior to those in the open and gardeners' classes, the Dahlias, Asters, and Marigolds being far superior.—W. K. W.

#### READING AUTUMN SHOW.

THE autumn Show of the Reading Horticultural Society was held in the Abbey Ruins, Reading, by permission of the Mayor, on Thursday, August 25th. The Show ground is a space of some 250 feet by 100 feet within the massive walls—5 feet thick or more—of the old Abbey, and it was roofed by a broad expanse of canvas. It is banked at the ends and sides, with two gentle slopes of turf towards the centre, thus there is every provision for the effective arrangement of the exhibits. These natural advantages were not wasted. On the right and left banks were judiciously staged the huge specimen plants and Ferns. At the upper end the lower portion of the terraced bank formed a capital stage for fruit. Above these were Liliacs in pots, Pelargoniums, &c. The bank at the lower end was devoted to Tree Ferns, Palms, &c., with Begonias, Achimenes, and Fuchsias below them. On the central side banks were Fuchsias and Liliacs, with cut flowers below them. Table plants and bouquets occupied two long tables down the centre of the enclosure, so that no space was wasted, and the general effect was very fine.

**SPECIMEN PLANTS AND GROUPS.**—Turning to the awards we have first to refer to specimen plants and groups. They were of fair average merit, collectively considered, containing nothing of an exceptionally high order, but the majority of the plants were clean and healthy. Nine stove and greenhouse plants were first asked for. There were but two competitors—namely, Mr. James, nurseryman, West Norwood, and Mr. Mould of Pewsey, who were first and second in the order given. Mr. James had a fine specimen of *Erica Eweriana* and another of *Ixora Regina*, with *Erica Marnockiana* also good. The other plants shown were *Allamanda Hendersoni*, *A. grandiflora*, *Dipladenia amabilis*, *Erica McNabiana*, *Agapanthus albus*, and *Croton Truffautianus*. The best of the second prize plants were *Statice profusa*, *Gloriosa superba*, and *Bougainvillea glabra*. Variegated or handsome foliage plants (six) formed an interesting class. Mr. James again took first place, having good specimens of *Latania borbonica* and *Macrozamia Dennisoniana*, with *Cycas revoluta* also in good condition. Mr. Howe, gardener to Sir Richard Sutton, Benham Park, came next, with Mr. Parham, gardener to H. J. Simonds, Esq., Caversham, third. A fine *Pandanus Veitchi* was a feature of the latter's collection. The last named exhibitor won with stove and greenhouse Ferns. He had a very fine lot, every member of which was worthy of mention. They were as follows:—*Alsophila australis*, *Davallia elegans* and *Mooreana*, very fine; *Cibotium Schiedei*, also fine; *Gymnogramma corysophylla*, and *Thamnopteris nidus*. Mr. Armitage, gardener to A. Clarke, Esq., Reading, showed a good *Adiantum formosum*, and a fair *Alsophila australis* amongst others for second prize. Messrs. Howe and Dockerill were equal third. One specimen stove or greenhouse plant in flower found Mr. Parham again to the front with a very fine *Lantana Le Grand*. This plant was 4 feet through and splendidly flowered. Mr. Howe followed with a moderate *Allamanda Hendersoni*. Mr. Mould won for a specimen new or rare plant, showing *Croton Mortei*, small, but very healthy and clean. Mr. Armitage received the remaining awards for the *Aralia-like Carica Papaya*, or Papaw Apple.

Two groups only were arranged, and they were not amongst the best we have seen. Mr. James' first prize arrangement was light and graceful, however, Orchids being most largely employed amongst flowering plants, rising from a groundwork of *Adiantum*, and backed by fine-foliage plants. Mr. Parham took second place, his group being largely composed of good sized specimen plants; it was certainly showy. Other awards in the plant classes must be summarised. They were for Lycopods, Achimenes, Fuchsias,

Balsams, Cockscombs, Liliacs, Coleuses, Palms, bedding Pelargoniums, variegated ditto, and Begonias. The principal prizewinners were Messrs. Ashby, gardener to Mrs. Fanning, Whiteknights; Bright, gardener to P. Karslake, Esq., Whiteknights Park; C. Midwinter, Gresham; Goodman, gardener to C. Hammersley, Esq., Bourne End; Parham, and Hatch.

**FRUIT.**—This was perhaps the feature of the Show. The classes were numerous, entries good, and the quality of the exhibits excellent. Mr. Ashby showed remarkably well in the principal class (eight dishes), having good Peaches, Cherries, Figs, and Apricots. The Grapes were large in bunch, but unripened. Mr. Goodman followed, also having good Peaches and Figs. Mr. Wells, gardener to Mrs. Ravenhill, Winkfield, was third. Mr. Jennings, of Farnborough, was first for a collection of six kinds, having capital Alicante Grapes and good Peaches. Mr. Cakebread, gardener to Sir Phillip Rose, Penn, was second, and Mr. Turton third. The Grape classes comprised some very fine fruit. Mr. Cakebread won with Black Hamburgs; the bunches were of good size, but the berries somewhat rubbed. Larger unfinished bunches took the second prize for Mr. Ashby; Mr. Best, gardener to C. W. Cbute, Esq., The Pynes, being third. A corresponding class for White Muscats found Mr. Sinclair, gardener to the Marchioness of Downshire, Easthamstead Park, to the front with small but well-ripened bunches of Muscat of Alexandria; Mr. Jennings being second; and Mr. Cook, gardener to T. Taylor, Esq., Rendcomb Park, third. Other prizes for Grapes were won by Mr. Cakebread, who showed some splendid bunches of Madresfield Court; Mr. Maher, with Gros Maroc in grand condition; Mr. Kneller, gardener to W. S. Portal, Esq., Malshanger Park; Mr. Ashby; Mr. Waite, gardener to Col. Hon. W. P. Talbot, Esher; and Mr. Wells. Peaches, Nectarines, and Apricots were best shown by Messrs. Waite, who had a splendid dish of Princess of Wales Peaches; Ponnid, gardener to G. May, Esq., Caversham, with Nectarine Peach, also good; Cox, gardener to J. H. Blagrave, Esq., Calcot; Goodman, with fine Humboldt Nectarines; Balchin, gardener to B. Simonds, Esq., Reading (Pine Apple Nectarine); Turton, gardener to J. Hargreaves, Esq., Maiden Erlegh, with splendid Moor Park Apricots; Maher and Cook, both with the variety just named. Figs were well shown by Mr. Parham. Plants (three dishes) were good too. Mr. Goodman won with Belle de Louvain, Yellow Imperatrice, and Kirke's; Mr. Howe following. Dessert and culinary Apples were excellent, Messrs. Hinton, gardener to J. Leslie, Esq., Reading; Pope, gardener to the Earl of Carnarvon, Highclere; Turton and Howe being the most successful exhibitors. Mr. Turton showed cooking Apples in capital condition. Pears were moderately shown by Messrs. Goodman and Turton, who received the chief awards.

**VEGETABLES.**—These were not very numerous, Tomatoes being shown in much the best condition. Onions and Celery were also good. Mr. Lockie, gardener to the Hon. G. Fitzgerald, Windsor, won with Cucumbers, staging Verdant Green; Messrs. Elliott (gardener to J. Hibbert, Esq., Braywick) and Best following. Mr. Read, gardener to F. Wilder, Esq., Purley Hall, won with Celery, showing Sutton's White Gem. Mr. Howe was to the front with Peas and Cauliflowers; Mr. Booker, gardener to C. Littledale, Esq., Twyford, with Marrows; and Mr. Jennings with Tomatoes. The latter were splendid, the variety being Sutton's Reading Perfection. Tomatoes were also finely shown by Mr. Lockie, who was second with the same variety. Mr. Kneller had the best Onions—a fine lot.

Cut flowers were plentiful and attractive, but the chief awards only can be briefly indicated. Dahlias, Phloxes, Roses, Hollyhocks, Gladioli, Asters, and Zinnias were all good, the principal prizewinners being Mr. Walker, Thame (Zinnias and Dahlias), Mr. J. S. Johnston, Newbury (Gladioli), Messrs. Perkins & Sons, Coventry (Roses), G. Phippen, Reading (Phloxes), C. Midwinter (Asters), and Messrs. Cbeal & Sons, Crawley (single Dahlias).

Special prizes were offered by several leading seedsmen. Messrs. Suttons' prizes for the best brace of Melons were won by Messrs. Pope (first), Allen, gardener to Sir F. Burdett (second), Goodman (third), and Robins, gardener to E. D. Lee, Esq. (fourth). The first-prize fruits were capital examples of Imperial Green-flesh, which ought to become popular. Messrs. Wells & Goodman secured Mr. Fidler's prizes for his Defiance Melon. Messrs. Sutton also offered prizes for collections of Potatoes. The former produced some fine lots of tubers. Mr. Allen won with nine dishes, Messrs. Pope, Hott (gardener to Major Allfray), Wells, and Lye following. With six dishes Mr. Hott was first, Mr. Allen second, Messrs. Lye and Pope third and fourth. The prizes offered for vegetables by Messrs. Sutton, Carter, and Webb drew some splendid produce, Messrs. Bowerman, (gardener to C. Hoare, Esq., Hackwood Park), Pope, and Waite having examples of far more than average merit.

Certificates were awarded by the Judges to Mr. Robert Owen for two fine double scarlet Ivy-leaved Pelargoniums, named respectively Robert Owen and Souvenir de Charles Turner; also to Mr. D. Bosley for Comet Aster, a large handsome flower of a soft rosy pink colour.

Mr. Gordon of Twickenham exhibited a fine group of *Lilium anatum*, not for competition, and Mr. Owen a collection of Tuberos Begonias, both exhibits being greatly admired.

#### WILTS HORTICULTURAL SOCIETY.—AUGUST 25TH.

THE third annual Show of this Society was held on Thursday in last week in the beautiful and well kept grounds of Salisbury Palace, kindly placed at the service of the Society by the Lord Bishop of the Diocese, glorious weather prevailing. The Earl of Radnor is President of the Society, the Right Worshipful the Mayor of Salisbury (Fred. Griffin, Esq.) is Chairman of the Committee, which consists of the leading gentlemen of the city and the gardeners of the neighbourhood, with Mr. W. H. Williams, the courteous, energetic, and business-like Honorary Secretary. One and all of these gentlemen are to be congratulated upon the success and excellence of the Show. The competition was good in most of the classes, and the exhibits of first-rate quality, while the management of the Show was everything that could be desired. Mr. Cypher, Mr. Lock, and Mr. Wills were the principal exhibitors of plants—the groups, which are a new feature at this Show, being a step in the right direction. Mr. Ward, Mr. Pratt, Mr. Inglefield, Mr. Warden, and Mr. Evans were the chief exhibitors of fruit. In the evening the palace, gardens, and grounds were illuminated, and the effect thus produced was very telling; the grandly flowered Magnolia trees in front of the palace shedding their fragrance among the thousands of people

who visited the grounds in the cool of the evening to witness the illuminations. Mr. Smith, who has ably presided over these interesting and well-cared for gardens for the last nine or ten years, is to be complimented upon the good keep of the place. The following is the list of the awards made by the Judges:—

**PLANTS.**—Division A (open).—For twelve stove and greenhouse plants, distinct, six foliage and a like number of flowering, £15, £10, and £5 were offered, the first prize being given by the President, The Right Hon. the Earl of Radnor, Lord Lieutenant for the county of Wilts. Three good collections were staged, and much time was spent by the Judges in determining the relative positions of the two excellent lots of plants staged by Mr. Cypher of Cheltenham, and Mr. Lock, gardener to B. W. Cleave, Esq., Crediton. Ultimately the premier position was accorded to the first named exhibitor for a very fine lot, consisting of a grand *Cycas revoluta*, *Cycas circinalis*, *Kentia australis*, *K. Fosteriana*, *Croton Sunset*, *C. Queen Victoria*, a large and well coloured plant; a finely flowered *Clerodendron Balfourianum*, *Bougainvillea glabra*, grandly flowered; *Erica Marnockiana*, a large fresh and well flowered plant; *E. Irbyana*, *Ixora Pilgrimi*, and *Ixora amabile*, the last named three being his weakest plants. Mr. Lock's best plants were *Latania borbonica* of immense size and in fine condition; a large, fresh, and profusely flowered *Erica Eweriana superba*, *Ixoras*, and highly coloured *Crotons Warreni* and *Williamsi*; his *Allamandas* were weak. Mr. Wills, gardener to Mrs. Pearce, The Firs, Bassett, Southampton, was third, showing smaller but creditable plants. Mr. Lock was a good first for six stove and greenhouse plants in bloom, with grandly flowered plants of *Allamanda Hendersoni*, *Clerodendron Balfourianum*, *Ixora Prince of Orange*, &c. Mr. Wills was second, his best plants being *Phœnocomma prolifera Barnesi*, *Erica Eweriana superba*, and *Clerodendron*. Mr. Curry, gardener to Colonel Pepper, Milford Hill, Salisbury, was third; his best plant was *Ixora Williamsi*. Mr. Lock was first for six exotic Ferns with good, fresh, even plants, the most noticeable being a *Gleichenia* several feet over. Mr. Wills was second, showing a good half dozen; and Mr. Evans, gardener to Lady Ashburton, Melchet Court, Romsey, a creditable third. Mr. Wills was a good first for six *Fuchsias*, showing medium-sized, fresh, and well-flowered plants. No second was awarded. Third, Mr. Tubb, gardener to Mrs. Ferryman, Redlynch House, Downton. In the class for six *Begonias*, distinct, only two lots were staged by Mr. Thornton, gardener to Mrs. Greenwood, The Cliff, Harnham, Salisbury, and Mr. Tubb, and they were accorded a second and third prize in that order.

In the class for a group of plants arranged for effect on 100 square feet, prizes ranging from £5 to £3 were offered, and were won by Mr. Lock, Mr. Wills, and Mr. R. West, gardener to Mr. G. R. Wigram, Northlands, Salisbury, in the order of their names. The first and second prize groups attracted a great deal of attention, not only on account of the choiceness and suitability of the plants used, but more particularly for the good taste displayed in arranging them; and it took the Judges some time to make the awards. Mr. Lock's arrangement was light and very effective, having a fine plant of *Cocos Weddelliana*, drooping gracefully over choice flowering and bright and silvery leaved plants of various heights set in a carpeting of *Maidenhair Fern*. Mr. Wills's group was a little too massive, being a departure from his style of a few years since.

**Division B (gentlemen's gardeners).**—For a group of plants arranged for effect in a semicircle, diameter 10 feet, £5 (given by Messrs. Keynes, Williams & Co., Salisbury), £3, and £2 were offered and brought out a capital competition. First Mr. Inglefield, gardener to Sir John Kelk, Bart., Tedworth, Marlborough, with a very good arrangement of suitable plants, but had fewer been used the group would certainly have been more effective, and on this account Mr. Lock, who was placed second for a light arrangement, ought to have been accorded first place; Mr. Wills was a good third, an extra prize going to Mr. Curry.

**Amateurs.**—For a group of plants of the same dimensions as that just mentioned a first prize Jubilee cup, value £5, given by the Right Worshipful the Mayor of Salisbury, £2, and £1 being given by the Society as second and third. These prizes were keenly contested. Mr. Charles Burch, Oxford Avenue, Southampton, was first for a very good and tastefully arranged group; second Mr. Edward Brown, Portland Place, Salisbury, with a very bright but too formal arrangement; Mr. Pearce, High Street, Salisbury, was third. A group, consisting of well-flowered *Liliums*, &c., intermixed with *Maidenhair Fern*, and having a double edging of the same graceful Fern and *Mesembryanthemum cordifolium variegatum*, and a piece of artistic rustic work in the background, not for competition, by the Messrs. Keynes, Williams & Co., at the lower end of the tent, was greatly admired. Class 9 was for a group of plants, arranged for effect, in a semicircle of 8 feet, not open to exhibitors in the preceding class. First, Mr. John Curry, with a bright but somewhat heavy arrangement; second, Mr. J. Hinxman, gardener to Mr. Gregory, Salisbury; third, Mr. Tubb. Mr. Hinxman had the best six Ferns; Mr. Nightingale, The Mount, Wilton, the second best; and Mr. Lovibond, St. Anne Street, Salisbury, the third best. Mr. E. L. Brown was first for six *Zonal Pelargoniums*; Mr. T. S. Fletcher, Wilton Road, Salisbury, was second, and Mr. Curry was third. Mr. Brown had the best four variegated foliaged *Pelargoniums*, and Mr. Rockett, gardener to Mr. George Smith, Wilton Road, had the best six *Coleuses*, showing creditable plants.

**FOUR.**—Division D (gentlemen's gardeners).—Four collections of eight kinds were staged, the contest for the premier award being between Mr. Ward, gardener to the Earl of Radnor, Longford Castle, Salisbury, and Mr. Pratt, gardener to the Marquis of Bath, Longleat, Warminster, the remaining two being a long way behind either of the above. The Longford collection, which perhaps was the finest ever staged from those gardens, won first honours by a few points. The dishes comprised grand bunches of *Madresfield Court* and good *Muscat of Alexandria Grapes*, large and highly coloured *Pine Apple Nectarines*, large *Castle Kennedy Figs*, Best of All *Melon*, *Moorpark Apricots*, a good *Queen Pine*, and *Dr. Hogg Peach*. Mr. Pratt's best dishes were *Smooth Cayenne Pine* and *White Muscat Grapes*. Mr. Evans was third. Mr. Pratt had the best *Pine Apple*, showing a good *Smooth Cayenne*. Mr. Bull, gardener to General Sir R. Buller, Downes, Crediton, being a good second. Mr. Pratt was first for three bunches of *White Muscats* out of seven lots staged, with good examples, being followed closely by Mr. Budd, Lockerby Hall, Romsey, and Mr. Northeast, Norton House, Heytesbury. For a like

number of *Black Hamburg* Mr. Inglefield was first with large, well-coloured bunches, carrying a good bloom; Mr. Charles Warden, gardener to Sir F. H. Bathurst, Bart., Clarendon Park, being a capital second with smaller but beautifully finished bunches; Mr. Flight, Twyford, Winchester, was third. In the corresponding class for three bunches any other *Black* Mr. Ward was first with well-proportioned bunches of *Madresfield Court*, followed closely by Mr. Warden with the same variety, beautifully coloured, and having a good bloom, but smaller in bunch and berry than the Longford examples; Mr. Flight was third. In the any other white class Mr. Warden was first with good bunches of *Buckland Sweetwater*, large in berry and well coloured, Mr. Ward being a very close second with good examples of *Foster's Seedling* well coloured, Mr. Flight being third. *Melons* were not largely shown, none being put up by local growers: first Mr. Wilkins, gardener to Lady Theodore Guest, Inwood, Henstridge; second Mr. Flight. Mr. Inglefield had the best dish of *Peaches* in the Show, showing large, well-coloured fruits of *Walburton Admirable*; second Mr. C. Pay, gardener to Mrs. Morrison, Ampworth Lodge, Downton. Several fine dishes of *Nectarines* were staged, Mr. Ward taking first with good examples of *Pine Apple*; Mr. Browning, gardener to Canon Sir Talbot Baker, Bart., Blandford, was second with *Humboldt*. Out of several lots of *Apricots* Mr. Haines, gardener to the Earl of Radnor, Coleshill House, Highworth, Berks, was well first, and Mr. Wilkins was a close second. Mr. Browning was first for twelve *Plums*, and Mr. Ward was second, both showing good *Green Gage*.

Mr. Browning was again to the front for six dishes of *Apples*, three dessert and three culinary, with a good clean even lot; Mr. Evans was second, and Mr. Fred Smith, gardener to the Lord Bishop of Salisbury, was a good third. Mr. Warden was first for four dishes of *Pears*, distinct, his lot including a nice coloured dish of *Windsor*, Mr. Smith being a good second.

**Amateurs.**—For a collection of six kinds of fruits Mr. Brown was a good first, his collection including creditable *Black Hamburg* and fine *Peaches*, the second position going to Mr. J. Hinxman. Mr. Lovibond was first for two bunches of *Black Hamburg Grapes*, and Mr. Hinxman was second. The last named exhibitor was a good first for white *Grapes* with creditable bunches of *Foster's Seedling*, Mr. Lovibond securing second position with the same variety rather green. Mr. Brown was easily first for six *Peaches* with large handsome fruits of *Bellegarde*, Mr. Curry being second. Harcourt Coates, Esq., M.D., Salisbury, was a good first for twelve *Plums*, showing large well-ripened fruits of *Washington*, which appeared to have been ripened under glass. C. W. Gater, Esq., Oakley, Milford, Salisbury, was a good second, showing large fruits of what appeared to be *Kirke's*, carrying a fine bloom. Mr. W. P. Aylward, Salisbury, had the best three dishes of dessert *Apples*, showing ripe evenly matched fruits. Mr. Harcourt Coates was second, the last named exhibitor being first for a like number of dishes of culinary *Apples*, and Mr. George Smith, Wilton Road, Salisbury, was second. Mr. Coates was the only exhibitor of three dishes of *Pears*, for which he received first prize.

**VEGETABLES (gentlemen's gardeners).**—The only class provided for vegetables, to be competed for by gentlemen's gardeners, was a collection of twelve kinds, and three or four good lots were staged. The tug of war, however, lay between Mr. Wilkins and Mr. Haines for first place, which, after a very close scrutiny by the Judges, was accorded to the former, whose collection included some grand specimens of *New Intermediate Carrots*, being straight, long, clean, and of a beautiful colour, three large close heads of *Laing's new Cauliflower*, *Sutton's Perfection Tomatoes* very good, *Telegraph Cucumber*, *Ne Plus Ultra French Beans*, good *Pride of the Market Peas*, *Moore's Cream Marrow*, *Rousham Park Onion*, *Inwood Seedling Globe Artichoke*, good *Potatoes*, and *Perfection Beet*. A truly grand collection for the season, and tastefully set up. Mr. Haines, as already hinted, was a very close second, only losing a few points in his *Carrots*, *Tomatoes*, and *Cauliflowers*. Mr. Inglefield was third with creditable produce. The amateurs and cottagers also staged capital kitchen garden and allotment produce in their respective classes.

**CUT FLOWERS (gentlemen's gardeners and amateur).**—In the class for twenty-four *Roses*, distinct, Mr. Warden was a good first, showing a fresh, even two dozen blooms, his best being *Dr. André*, *Sénéateur Vaisse*, *Alfred Colomb*, *Duke of Connaught*, and *Lady Mary Fitzwilliam*; second, Mr. Flight, whose stand, though not quite so even as Mr. Warden's, included several fine blooms. Mr. Frank Hatch, Wyndham Road, Salisbury, had the twelve best blooms, distinct. His best blooms were *Madame Lambard*, *Maréchal Neil*, and *Marguerite de St. Amand*, Mr. Warden being a good second. Mr. West had the best twelve *Pompon Dahlias*, and Mr. Evans the best dozen spikes of *Gladiolus*. Mr. Budd had the best eighteen bunches of cut flowers, distinct, his stand including several choice pieces of *Orchids*. Mr. Evans was second. This collection contained two fine spikes of *Saccolabium Blumei*. The prizes for the best dozen bunches of cut flowers went to Mr. Browning and Mr. Inglefield in that order.

In the open class for the best dressed vase for dinner table decoration, Mr. J. R. Chard, Stoke Newington, London, was first for a very good arrangement, Mr. Cypher was a close second, and Miss Flight a good third. In the amateur (ladies) classes Miss Agnes Flight was a good first for dressed vase for a like purpose to that indicated in the preceding class. Miss Catherine Lovibond, Salisbury, was second, and Miss Alice Howard, Hackney, London, was third. Miss Brown was first in the next three classes, followed by Miss Lovibond and Miss Burt, Winterbourne.

**Miscellaneous plants not for competition.**—Messrs. Keynes, Williams and Co. made a grand show of *Roses* and *Dahlias*, the latter commencing with stands of *Pompons*, the most notable of these being *Sappho*, *Darkness*, and *Lady Blanche*, followed with several stands of *Cactus* varieties, conspicuous among which were *Constance*, a beautiful white; *Annie Harvey*, rich crimson maroon; *Miss Sherriff*, orange salmon; *Miss Beadon*, buff, shaded red, &c. Then followed several dozen stands of large uniform blooms of show varieties, having in the background large spikes of *Gladiolus* of various colours, thereby rendering the side stage in the large tent containing the *Ferns*, &c., a most interesting feature in the Show. Messrs. Brittan & Son, the *Waterloo Nursery*, Salisbury, also had a grand display of *Roses*, *Dahlias*, and decorative plants in the same tent. Mr. H. J. Gibbs, Manor Farm Nursery, Salisbury, also contributed stands of *Carnations*, *Zinnias*, *Gladiolus*, *Dahlias*, &c. Mr. Smith staged several large healthy



specimens of exot: Ferns, &c., from the palace gardens. Messrs. J. Lywood, of Catherine Street, Salisbury, also contributed cut flowers.

#### SANDY AND DISTRICT HORTICULTURAL SOCIETY.

THE nineteenth of these popular annual gatherings was held on Friday last as heretofore in the pretty and convenient grounds of J. N. Foster, Esq., at Sandy Place, and within a quarter of a mile of the railway station; and although the season must be considered an unpropitious one for vegetables, the staple of the locality, and notwithstanding the clashing of the Exhibition with some concurrent local gatherings, it must be noted as one of the most successful, if not the largest, that the Society has yet held. In point of numbers of entries there was on this occasion, as might have been anticipated, a considerable falling off, and especially was this evident in the diminished display of single dishes of vegetables, but in the quality of the exhibits there was a patent advance. Frequent showers which barely more than cooled the ground were almost welcomed even by ladies in light holiday attire, and after the long spell of drought which has severely affected the district did not appear at all to interfere with the comfort or pleasure of the visitors; and indeed the amount of gate-money received attested that for the surrounding counties Sandy Show is as popular as ever.

The display of stove and greenhouse plants, although somewhat marred by being awkwardly raised at an elevation of some 6 or 8 feet on an unsightly wooden platform in a narrow tent, and which had to be studied with the head placed back at an angle of 45° or more, was a most satisfactory one. The first prize in the open class for ten stove and greenhouse plants was awarded to Mr. W. Finch, gardener to H. Marriott, Esq., Coventry, who had grand specimens of *Stephanotis floribunda*, *Lapageria rosea*, *Ixora Williamsi*, *Statice profusa*, *Rondeletia speciosa nigra*, *Allamanda nobilis*, and four *Ericas*; Mr. W. Rabbitt, gardener to Gen. Pearson, C.E., The Hazells, Sandy, was a very close second with large plants, several being as well grown as those in the winning lot, but one or two specimens hardly being sufficiently advanced in bloom. Mr. Rabbitt showed *Bougainvillea glabra*, *Stephanotis floribunda*, *Ixora Fraseri*, *Dipladenia amabilis* in fine condition. Mr. Parker, of the Rugby Nurseries, had smaller but well-flowered specimens, to which third prize was awarded. For six foliage plants (nurserymen excluded), Mr. Redman, gardener to J. H. Goodgames, Esq., Eynesbury, St. Neots, was first, and Mr. Rabbitt second. For six stove and greenhouse Ferns, Mr. Tillbrook, gardener to Bateman Brown, Esq., Houghton, Hunts, took leading position, and for six hardy ditto Mr. Rabbitt. For three Cockscombs Mr. Redman was first, and for six showy and well-flowered Begonias W. H. Aphthorp, Esq., Cambridge, held first place. For twelve Zonal Pelargoniums, Mr. Rabbitt, a constant winner in the competition, was again first, but the plants hardly in so good form as usual. Queen of the Belgians as a fine white, and Mrs. Patchett as a carmine-cerise, were conspicuous as good specimens.

Cut flowers, especially Roses, Dahlias, and Gladioli, were well represented. In the open class for forty-eight cut Roses (not less than twenty-four distinct varieties), Messrs. Paul & Son, of the Old Nurseries, Cheshunt, showed two good boxes of good sized, clean, and well-coloured blooms, and were placed first. Madame Alfred Vy was noticeable as a well-shaped, stiff-petaled, purplish-crimson flower, and said to be a useful autumn Rose. Blooms of Chas. Lefehvre, H. Schultheis, Madame V. Verdier, Madame Margottin, Marshal Wilder, Innocente Pirola, Duke of Teck, Paul Neyron, Niphotos, Etienne Levet, Cornelia Kock, Prince Arthur, and G. W. Head were all good in this stand. Messrs. Burrell & Co., of Howe House Nurseries, Cambridge, came second, having fresh but a trifle smaller flowers. In this stand Niphotos, Jean Ducher, Catherine Mermet, Duke of Teck, Dupuy Jamain, Maréchal Niel, Dr. Andry, and Duke of Albany (as shown much like Fisher Holmes) were well represented. Messrs. J. & W. Burch, Rose growers, Peterborough, came third, having bright blooms of Alphonse Sonpert and Duchess of Bedford; Pierre Notting, F. Lesseps, and Niphotos also being attractive. Mr. J. Honse, of the Peterborough Nurseries, also showed some fine blooms set up in his neat-looking registered stands, where moss is dispensed with, and although this may not altogether displace the real article, in seasons of drought like the present the invention seems a suitable and most desirable one. For Gladioli it seems especially adapted. Amongst Mr. House's Roses a bloom of Madame Eugene Frey, a dark H.P., although small, attracted attention as a possible show Rose of the future. Souvenir de Thérèse Levet in Mr. House's collection was remarkably curious and distinct, and unless in Rose company would scarcely be recognisable as a Rose. For twenty-four cut blooms (nurserymen excluded) Mr. E. B. Lindsell, of Bearton, Hitchin, was an easy winner, and notwithstanding the Hertfordshire plague of earwigs, which the exhibitor states has impaired his late blooms, the stand was a creditable one.

In the open class for twenty-four Dahlias, the "all round" Mr. R. Petfield, gardener to C. Thornhill, Esq., Diddington, Hunts, distanced the veteran Mr. H. Glasscock of Bishop's Stortford, who is always "off" in tropical weather. Mr. Petfield's first prize stand contained the following flowers in champion form—viz., Miss Cannell, Willie Garrett, H. Weir, Defiance, Goldfinder, Mrs. Freeman, Primrose Perfection, Jos. Henshaw, Jas. Stephen, Jas. Cocker, very fine; Mrs. G. R. Gifford, Prince Bismarck, Jos. Ashby, Shirley Hibberd, Mrs. Gladstone, J. Standish, J. B. Service, J. W. Lord, Constancy, Prince of Denmark, fine; Mrs. Dodds, Illuminator, Mrs. Langtry, and Imperial. In Mr. Glasscock's stand, which was placed second, were good flowers of Chas. Ridley, Prince of Denmark, J. V. Quennell, and Mr. H. Glasscock. For six Fancy Dahlias, Mr. H. Glasscock was placed first, having good flowers of Duchess of Albany, Mrs. Browning, Wizard, and Chorister; Mr. Petfield, who was here second, having Gaiety, Duke of Albany, Rev. J. B. Camm, Hercules, E. Fisher, and H. Eckford. For twelve Show Dahlias Mr. G. Arnold of Lighton Buzzard, Beds, was first with some grand flowers, including a bloom of Mrs. Douglas, probably the finest flower in the Show. A good stand was also exhibited by Mr. Aphthorp. Mr. W. Bourne of Cambridge was first for some fine African Marigolds, and Mr. Petfield for Zinnias, which were good for the season. Asters were small, and showed the effects of the drought. For twenty-four spikes of Gladioli, Messrs. Burrell & Co., Cambridge, were first with very fine spikes, including several of their own seedlings, Grand Mogul and another unnamed of the Horace Vernet type, having bold, well built flowers, and colours well defined. Mr. J. Honse having also a fine stand, for which he was awarded second prize. Very good Hollyhocks came from Messrs. Webb & Brand of Saffron

Walden, including Cygnet, a very clear well-formed white; Alfred Chater, Purity, F. G. Dougal, W. Archer, Golden Drop, Carus Chater, Goliath, and Prince Arthur. In the competition for the silver medal offered for the best collection of cut flowers by Messrs. Wood & Son of Wood Green, Mr. W. Finch of Coventry secured the prize.

FRUIT.—For the collection of eight distinct kinds of fruit (Pines excluded) Mr. G. R. Allis, gardener to Major Shuttleworth, Old Warden, worthily secured the first place with splendid Alicante and Buckland Sweetwater Grapes, Barrington Peaches, White Ischia Figs, Nectarines, Moorpark Apricots, Melon and Cherries. Mr. Tillbrook was placed second, his Muscat Grapes being very fine, but hardly finished. For six distinct kinds Mr. G. Warhoys, gardener to Mrs. Medland, St. Neots, took the leading prize. For two bunches of Black Hamburg Grapes Mr. W. H. Murfin of Little Stanghton, Hunts, was first, and Mr. Tillbrook second. For two bunches of any other variety of black Grapes Mr. Tillbrook was first with fine Gros Maroc. For two bunches of Muscat of Alexandria Mr. Thos. Nutting, gardener to J. B. Maple, Esq., Childwickbury, St. Albans, was first with large fruit, and bunches nearly finished, and Mr. H. Edwards, Cambridge, second. For two bunches of white Grapes, any other variety, Mr. Allis was first in his usual style with very fine well ripened bunches of Buckland Sweetwater. The display of Grapes was altogether a good one and the competition strong. For a scarlet-flesh Melon Mr. Allis was also first, and Mr. Cook, gardener to Col. Stuart, Tempsford Hall, second; and for a green-flesh Melon Mr. R. Carter, gardener to Col. Duncombe, Waresley Park, was first; and for six Peaches Mr. Allis. Mr. Cook was also the winner with a fine dish of Florence Cherries. In the competition for best collection of Tomatoes three interesting collections were shown, the first prize being awarded to Mr. Tillbrook for four large varieties, two red and two yellow. Mr. Rabbitt was second, and Mr. W. Bourne third, the latter showing a distinct and luscious looking small yellow seedling. The first prize for cooking Apples was awarded to Mr. J. Beaumont of Eaton Socon, for Peasgood's Nonsuch.

VEGETABLES, an especial feature at Sandy, were, if more sparingly shown than usual, admirably represented. For a basket of twelve varieties Mr. G. Vyne, gardener to C. Franklin, Esq., Bedford, was first, and Mr. Ellis, gardener, Pemberly, Bedford, a good second. For a collection of six varieties, Mr. G. Woodham, Kempston, Beds, was first, and Mr. Carter, Waresley, second. Mr. Rabbitt was awarded first for a very fine brace of Tender and True Cucumbers, nearly 30 inches long. Mr. W. Pepper, Welwyn, had a similar position for excellent Intermediate Carrots and for a dish of Laxton's Evolution Peas, by far the best in the Show. For a collection of Potatoes, Mr. R. Carter was first with Snowdrop, and Mr. Bresee (excellent specimens), Vicar of Laleham, Beauty of Kent, Adirondack, and International, also good. Mr. J. Bradford, Thorney, Cambs, was second. For the best dish of white kidney Mr. T. Scotchbrook, Whittlesey, Cambs, was first with International, and Mr. All's second with Snowdrop. For round white Mr. Scotchbrook was first with Schoolmaster, Prizetaker coming in as the best coloured kidney, Reading Russet as the best coloured round. But by far the best Potatoes in the Show were those from Mr. J. House, Peterborough, in the market gardeners' tent, his Magnum Bonums, Reading Russets, Trophy, Edgecote Purple, Snowdrop, and Cosmopolitan having in more favourable seasons been rarely equalled, but from unaccountable and hesitating management in this department part of the exhibits were not allowed to be staged, and so other prizes were reluctantly awarded. The prize off red by Messrs. Harrison & Sons, seed merchants, Leicester, for six kinds of vegetables, four to be grown from their seeds, was awarded to Mr. W. Johnson, Bedford.

Mr. T. S. Ware, of Tottenham, had a good display of decorative, Pompon, and single Dahlias. The best of the decorative sorts were William Rayner, a striking æsthetic flower, Mrs. Hawkins, Henry Patrick, and William Pearce (yellow). Amongst the Pompons were Nemesis, a very small self-chocolate flower; Pure Love, a very delicate peach; Eccentric, very curious orange and buff; Profusion, Gem (bright scarlet), and Brunette. Messrs. J. Cheal & Sons, of Crawley, Sussex, also made a very effective display with these Dahlias, and their mode of setting up the decorative flowers as single blooms, backed up with their foliage, proved most attractive. Amongst the Cactus type, Lady M. Marsham (crushed strawberry), Empress of India (very dark), General Gordon, Mrs. Tait (imbricated white), Picta formosissima, Juarezi, and Cochineal were very effective. In singles, the best were Beauty of Uplands, Ellen Teiry, Mrs. Rennett (striped), F.C.C., Jas. Kelway, Sunset, Silver King, Amos Perry, and Queen of Singles (mauve). The best of the Pompon type were Crawley Gem, Little Bohy, Emotion, Favourite, Fair Helen, Lightning, and Dr. F. Junker. Messrs. W. Wood & Son, of Wood Green, showed specimens of their "Thanatos" insecticide, universal plant food, manures, and other specialties; and Mr. William Colchester, of Ipswich, samples of his Ichthemic guano.

#### FALKIRK.

THE above Show was held in the Falkirk Town Hall, on Friday and Saturday, 26th and 27th ult. It was one of the finest, although not the largest, that has been held, and far surpassed others with higher pretensions. Many of the exhibits were extraordinary examples both in size and quality, the vegetables especially so. Leeks measured 10 inches long and 2½ in diameter, finely blanched; Onions weighed 1½ lb.; Parsnips and Carrots were simply perfection, the former measuring upwards of 2 feet 6 inches long by 3 inches in diameter; Celery was also of extra quality. Plants and cut flowers were excellent, as also was the fruit. Miss Cochran, Comely Park House, Falkirk, exhibited some wonderfully large Norwegian Red Currants. Messrs. R. B. Laird & Sons exhibited a table of plants 30 feet by 6 feet nicely arranged, and gave grand effect to the Exhibition; the Crotons and Dracænas were very highly coloured. The same firm also exhibited single and Pompon Dahlias, which were much admired; they were arranged with great taste. Amongst the single varieties we observed a number of new ones worthy of special notice; Scotch Lassie, beautifully striped; James Kelway, white, purple edged; John Sutherland, orange, striped scarlet; Mrs. H. M. Murray Stewart, edged pink; and amongst the Pompons, Eccentric, a novel and pleasing variety; Dandy, crimson purple. Mr. M. Campbell, Blantyre, exhibited two stands of Dahlias, remarkably well grown and very large. The Carnations exhibited by the same gentleman were excellent. The Judges declined to pass any remarks upon several



promising seedling Pansies, owing to the season being too far advanced. Mr. M. Cuthbertson, Rothesay, exhibited a large number of superior cut flowers in great variety.

The honey, owing to the fine season, was highly meritorious. The drift honey surpassed anything we have seen, and it was a difficult task for the Judges to decide which was the best. The designs, now so popular since "A Renfrewshire Bee-keeper" threw out the hint about these many years ago, were attractive. As usual the Stewarton supers were the centre of attraction and were very fine. The observatory hives were novel, but the common error of lifting the combs from the stock hive and placing them in the observatory a day or so before the show, instead of allowing the bees to work the comb in them, and showing the workings to the best advantage, spoiled these exhibits.

#### NEWCASTLE-ON-TYNE JUBILEE EXHIBITION.

AUGUST 31ST, SEPTEMBER 1ST AND 2ND.

THE Botanical and Horticultural Society of Durham, Northumberland, and Newcastle-on-Tyne opened their autumn Show on Wednesday, August 31st, in the Royal Jubilee Exhibition grounds at Moor Edge, Newcastle, and though they have had a successful career of sixty-three years it proved one of the most successful ever held in that busy city. A large piece of land was enclosed on the site recently occupied by the Royal Agricultural Society's Exhibition, and upon this three spacious marquees were erected 200 feet long each, and 48 feet wide, with central and side stages in two of them, the third being reserved for the large specimen plants and groups. The marquees were placed parallel with each other, so that the exhibits were readily inspected by the large numbers of visitors which were attracted to the Show, and to whom also special facilities were afforded in the way of excursion trains from the northern counties.

A very liberal schedule was compiled, a total of £421 being offered in ninety-five classes, besides fifty-five classes devoted to artisans. The first named classes were in three divisions, A, open to all, comprising fifty-seven classes, with a total of £324; B, open to all (nurserymen excepted), twenty-four classes; and C, open to amateurs only, thirteen classes. Division A, as will be seen from the prize money, was the most important, including all the large classes for plants, table decoration, cut flowers, and fruit, all of which were shown in surprising numbers. The prizes for plants ranged from £12 to 10s.; £10 were offered as the first prize for the most tastefully decorated dessert table, 10 feet by 5 feet 4 inches. The substantial prize of £6 and the Wood Jubilee medal were offered for twenty-four Dahlias in the cut bloom classes; but the special interest of the Show centred in the fruit classes, for which liberal provision was made. Much attention was attracted by the class for a collection of fruit, fifty dishes, Pines excluded, for which the prizes were £25, £15, and £10, or a total of £50 in one class. It could not be expected that there would be a large competition in such a class as this, but the valuable prizes induced three of our leading cultivators to enter the lists and test their strength. These were Mr. J. Hunter, Lambton Castle Gardens, Durham; Mr. J. McIndoe, Hutton Hall Gardens, Guisborough, Yorkshire; and Mr. J. H. Goodacre, Elvaston Castle Gardens, Derby, the collections making an excellent and extensive display. Other fruit classes are well represented, and there are over 500 dishes of fruits staged besides 100 bunches of Grapes. There were eight entries with a collection of eight dishes of fruit, nine with four dishes of fruits, the same number with six hardy fruits, twelve with six bunches of Grapes, fourteen with two bunches of Black Hamburgs, ten with two bunches of black Grapes any other variety, the same number with White Muscat, Buckland Sweet-water, and any other white Grape. The competition was exceedingly keen with Melons (twenty-nine), Peaches (seventeen), Nectarines (sixteen), Apricots (fifteen), Cherries (twenty), Apples, Pears, Plums, and Tomatoes being all strongly represented.

The plant classes included nearly 300 flowering and foliage plants, besides nearly as many in the smaller classes. Dessert tables, epergnes, bouquets, &c., are largely shown, and the total number of cut blooms of Dahlias, Gladioli, Asters, Roses, Carnations, and Hollyhocks amount to nearly 3000. There are 260 exhibitors, and some of these entered in as many as twenty classes.

In number and quality of exhibits the Show is a magnificent one, fruits, plants, and flowers being grandly represented. The three collections of fifty dishes of fruit were very close in quality, but some difficulty has been experienced in making up the number. The prizes were awarded as follows:—Mr. Hunter, Lambton Castle Gardens first, Mr. McIndoe, Hutton Hall Gardens, second, and Mr. J. H. Goodacre, Elvaston Castle Gardens, third. Mr. J. Hunter was also first with eight dishes, followed by Mr. R. Westcott, Baby Castle Gardens, Mr. McIntyre and Mr. McIndoe. With four dishes, Messrs. Westcott, Parker (Impney), and Hunter were the prizewinners. The best hardy fruits were from Messrs. Short, Westcott, and Parker. In the Grapes classes, Mr. Witherspoon was first with six grand bunches, followed by Messrs. Hunter, McIndoe, and Laidler in a very strong class. Other successful exhibitors with Grapes were Messrs. McIndoe, Goodacre, Luck, Hunter, and Witherspoon. Pine Apples, Pears, and miscellaneous fruits are all well shown, but vegetables are few. Specimen plants include some fine fresh-flowering examples, and amongst the foliage plants Crotons are very highly coloured. In the open class for eight flowering plants Mr. G. H. Letts, Aske Gardens, won first honours. With six flowering plants Messrs. Nicholas, Gateshead, and Suffield were the prizewinners. Foliage plants from Messrs. Nicholas, McIntyre, and Methven (Heathfield Gardens), are excellent. Ferns also are very fine. Amongst cut flowers, Gladioli, Hollyhocks, Roses, Asters, and Dahlias are uncommonly good, honours being accorded to Messrs. Short, Harkness, Brown, Rogerson, Spoor, Walker, and Cocker & Son, Aberdeen.

Bouquets, wreaths, buttonholes, stands, and baskets of flowers form the prettiest feature of the Show. Very seldom is such a charming display seen. Dessert tables from six exhibitors are very tasteful and choice in quality. In the table and bouquet classes Messrs. Thompson, Chard, Cypher, and Perkins (Coventry) were the chief prizetakers.

The arrangements of the Show were admirably conducted by the courteous Secretary, James J. Gillespie, whose familiarity with the arduous duties of his office enables him to work out every detail in a highly satisfactory manner to all. We can only regret that the brief time at our disposal only permitted a hurried reference to the chief features of the Show, but fuller particulars will be given next week. Some tasteful exhibitors' cards were specially printed for this Show by Mr. Andrew Reid, Printing Court Buildings, Newcastle-on-Tyne, and the same firm prepared some handsome lithographed certificate cards, of excellent design, and which constituted additional awards of honour in certain classes.

In the central gardens of the general Exhibition several firms of nurserymen have interesting contributions, chiefly beds of ornamental Conifers and small shrubs, but these are very tastefully arranged in groups surrounded by excellently kept lawns. The latter are an important feature, and admirably illustrate the readiness with which good lawns can be formed from seed, as in some cases the seed was not sown until May 2nd, and the turf is now as dense and firm as if it had been formed for years. Messrs. Little & Ballantyne, Carlisle; Fell & Co., Hexham; R. Smith and Co., Worcester; and Mr. W. J. Watson, Newcastle-on-Tyne, are the principal exhibitors in this department, and all deserve much credit.

#### THE ROYAL HORTICULTURAL SOCIETY.

It is gratifying to observe from last week's issue of the Journal that the report of the Pear Congress has at last been issued. I have no doubt that the majority interested will be pleased to avail themselves of a copy. I have the report of the Apple Congress, but can the reports of the Primula and Nareissus Conferences be obtained? I have tried to procure them and failed. I presume offering the report of the Pear Congress to the Fellows is a new departure on the part of the Council of the "Royal." It is what should have been done long ago, for it will do much to bring horticulturists in the provinces in sympathy with the Society and its work. Under the old system its benefits were in a large measure confined to those who could take part in its shows and meetings, or, at the most, those who live within easy reach of London. I am glad to think the Council see that the support of gardeners and others in the provinces is needed. I do not think it will be tendered on a large scale, unless some return is made in the shape of official reports, either in book form or through the gardening periodicals, of the Society's work and doings.

The reorganisation scheme put forward a short time ago, as published in the Journal, is a step in the right direction, but outsiders will not reap much benefit by paying their half-guinea or other sum that might be determined if the finances be swallowed up in the maintenance of elaborate offices; that would cripple it at the outset. I should certainly favour a withdrawal to Chiswick, and start in such a manner as to husband the financial resources and at the same time show to those in the provinces what work the Society intends to do in the future in order to advance horticulture generally throughout the country; then, and not till then, do I believe a general support from the provinces will be given.

While the report of the Pear Congress issued for the good of the public will be highly appreciated, such work as conveyed in your notice of Vegetable Trials at Chiswick, page 45, July 21st, will be strongly condemned. The Society should put its foot down and refuse to accept for trial plants fruits or vegetables that are not named. Amongst Tomatoes I see on page 161 that Messrs. Watkins & Simpson have a No. 1 and No. 3 highly spoken of. What good is such information to the public? Just now I am specially interested in Tomatoes and on the look out for the very best kinds, and so are many others that grow for market. Announcements under number are simply tantalising, and it is to be hoped in future that the "Royal" will not recognise anything for trial sent under number.—A GARDENER IN THE PROVINCES.

#### THE EARWIG PEST.

I KNOW not how others elsewhere are annoyed by earwigs, but this year they worry me to distraction. If I put a pair of trousers on I must first shake out the horrible creatures; if I cut a slice off a loaf I find one or more in the holes of the bread; if I get in bed I must first examine it. All my family are tormented by them, though the nausea caused at finding them in the food and on the wearing apparel. I write, however, to warn others to beware of their depredations on the wall fruit. A fortnight ago I had about four dozen Nectarines, and then I found them gradually disappear, all but the stones, which were left clean. I thought of wasps and slugs, but could find no slugs, and noticed the wasps never touched the fruit. After about a dozen and a half fruit disappeared I grew desperate, and smothered the tree with soot, thinking that would stop it, but to my surprise my desperate means of repelling the enemy was no remedy. I went out one night with a lamp, and then I was staggered, for so many earwigs together I never saw in my life. Heaps upon heaps there were attacking my fruit, and I had my revenge, for seizing a can of crystal oil I poured it on them and slew many hundreds. The next night they were as thick as ever, but I massacred them again, and am thinning them down, but am afraid my tree will be sadly damaged.—H. S. EASTY.

#### ASPARAGUS CULTURE.

(Continued from page 155.)

TRANSPLANTING.—One-year-old plants are best. For the 18-inch rows plant on the flat, for the other distances let the height of the

ridges be as before stated. The early part of April, or when the plants have grown 2 or 3 inches, is the proper time to plant. Lift the whole carefully, and keep the roots as much as practicable from the drying influences of the atmosphere. Stretch a line at the required distance, or along the centre of each ridge, and make a sloping cut on both sides the lines at an angle of about 45° where the plants are required, and extended enough so as to admit of the roots being placed straight in the sloping cut, and even on both sides. The plants are put astride the ridge at the exact distance apart, the sharp angle being knocked off so as to form a seat, and to insure having all the crowns level with the surface. Cover with fine soil, preferably leaf soil, just a little over the roots, or with the finest of the soil taken out, and if in clay soil cover with sand an inch thick and extending over the crown, pressing gently down with the hands. Return the soil to its form as when in the ridge, covering the crowns about 2 inches deep. If the soil be moist do not give water, but if the weather be dry apply water before covering up. Unless the weather is unusually dry further watering will not be necessary, but if it prove very dry afford supplies as needed to keep the soil moist. There is more to fear from wet than dryness, therefore only keep the soil moist and run the hoe frequently through the ground, alike to destroy weeds in the seedling state and to let in the sun, light, air, dew, and rain, and a good root action will be ensured.

**SECOND YEAR OF SEEDLINGS.**—First of the transplanted. The seedlings push strongly—one stout head—a hopeful sign. Frost may destroy it, causing another to spring the sooner. In any case a second head will make its appearance. If frost have destroyed the first head there is no choice, but both being present choose between the two, retaining the stronger, and cutting the other away. The second very often is the stronger; the first will have done some good by stimulating root action. Other shoots will spring sooner or later, and as we have the strongest yet made for stimulating root action and the best of the season to come we can afford to wait. When a third head appears compare it with the grass present, and if stouter let it grow, it will be the better for the shelter and root-making of its predecessor. Let both grow until the third week in May, or if a late season the end of that month or early June, then cut the older growth away in favour of the younger. But the secondary being smaller than the first cut them away as made, retaining the strongest shoot only appearing up to the time named. By or before midsummer another shoot may arise much stronger than that of the first reservation. Leave it and cut the other away. All after this are to be cut away as they appear, unless there spring a giant from the base of the last reservation, then allow both to run their course. This is the way to get the heads for the epicure.

We have another class of plant—viz., that of the previous year with two or three growths left, forming that number of crowns. Let the first heads remain until the appearance of the second, and being larger cut away the first in their favour at the close of May or early June. Any other heads appearing, and weaker, cut them away, reserving the largest two or three only appearing before and up to the time named. If a stronger shoot issue from the base of any reserved shoot before or by midsummer cut the older one away, and if a stronger still arise from the base of any reserved growth after midsummer let both grow together; but keep down all growths weaker than the reservations. This is the way to get fine heads in quantity. The transplanted will push ahead, and second growths will come stronger than the first, which will have been somewhat checked by transplanting. Make choice of the best one or two and at most three shoots present at the end of May or first week in June, and cut all others away, pursuing the procedure described above for untransplanted seedlings as regards subsequent growths.

The transplanted and untransplanted are now on a level. Any unprejudiced eye can see a difference—the transplanted are good, but the untransplanted are better. That, however, need not make any difference in the treatment. Dress with nitrate of soda and sulphate of ammonia at the rate of 2 ozs. per square yard, or 1 lb. each per rod (30½ square yards) in June, and mulch before the setting in of the dog days with any littery stuff at command, and over the whole surface of the ground right up to the plants. Give water frequently up to early September with the contents of liquid manure tanks and cesspools, but a good soaking between the rows every fortnight or three weeks from the middle of June is most advisable.

Staking and tying must be attended to in good time to prevent injury to the growths by wind. Keep the ground free of weeds. In autumn cut away the haulm after it has become leafless, placing a little littery manure over the crowns in cap form so as to throw off the wet, and point the ground over, burying the mulch as deeply as the roots allow.

**THIRD YEAR.**—Heads will be fit to cut. Remove the litter in March, and loosen the soil over and around the crowns carefully. This is to allow of the stems rising freely. The grass will come strong. Observe the same conditions as to reserving the best of the growths as in the second year, and as the plants after this year will be fit for any purpose we must apportion the growths to the plants and requirements, getting the selection over by early June, so as to secure well developed buds at the base of the growths, which is particularly advisable when the plants are required for forcing, and for affording a first cutting of good heads outdoors. As the growth is so will be the heads, therefore leave one only to insure giant heads, two or at most three to secure fine heads, and five for giving a quantity of grass. In the third year the plants must be prepared to furnish the harvest in the fourth, and from year to year afterwards, therefore the treatment given in the third year of the seedlings

or second of transplanted will be required in subsequent years, and may be best treated of under different headings.

**MANURING.**—In the spring of the third year of the seedlings, and second of the transplanted, apply a dressing of manure to the whole surface of the ground, except immediately over the crowns. In subsequent seasons the manuring may be done in autumn, as it generally is for convenience, but I consider February or early March a preferable time unless the manure be very crude and powerful, when exposure to the atmosphere for a short time before pointing under may be advisable. That, however, need not be made “a bone of contention;” but it is important that the manure be as fresh as possible, or so fresh as to be workable, and retaining all or most of its manurial properties. The soapy stuff which has had most of the ammonia steamed out, and much of the virtue left after the steaming washed out by rains, is not the manure for Asparagus. Manure from covered sheds, that from farmyards disposed thinly and saturated with urine, is the kind for Asparagus. The partially decayed stuff from hotbeds—three parts leaves, perhaps more, is infinitely better than the soapy stuff resulting from stable or farmyard manure laid up for months in a mountain-like heap.

**STABLE, FARMYARD, OR HOTBED MANURE.**—The first and last named are best for heavy or clay soil, and farmyard manure for light soil. If crude the littery or unworkable parts should be rejected, which will be useful for other purposes, and if saturated with the drainings of the dunghill or cesspools will be increased in value as manure or as a mulch. A thickness of 3 inches is a suitable dressing. It is the better for being spread and exposed to atmospheric influences for a few days before pointing in, as it should be as deeply as the roots allow not later than March, and always when the ground is in good working order, leaving the surface rather uneven, so as to allow of the rain entering freely.

**NIGHT SOIL.**—Powerful and very valuable, it is doubtful if this has an equal for Asparagus. It may be mixed with sufficient dry earth or ashes to make it portable, or about two parts more than of the manure. Earth closet manure, which should be kept dry, is equally serviceable. In any of the forms named it may be applied 3 inches thick. That mixed with soil is best for light, and with ashes for heavy soil. It is best applied in autumn or some little time prior to pointing in in March.

**PIGEON AND FOWL DUNG.**—These are powerful fertilisers, and should be kept thin and dry. An inch thick dressing is suitable, applied in June and lightly pointed in.

**BLOOD AND SLAUGHTERHOUSE REFUSE.**—Mix with two-thirds or two parts more of soil than of the blood and refuse, and turn them over two or three times—i.e., after lying in a heap about six weeks turn it over, and repeat in about a month, and in another month it may be applied to the Asparagus as a dressing 3 inches thick in autumn. Dead fish or the refuse of fishing stations may be treated and used similarly.

**SEAWEED.**—A 3-inch dressing on heavy, or 6-inch on light soil, may be given in March, and mixed with the soil as deeply as the roots allow. A mulch 3 inches thick may be given whenever obtainable, as soda and potash in this form are always appreciated, but I consider it best given in spring; all the same, lose no opportunity of applying it to the surface whenever obtainable.

**SALT.**—I have never observed any difference in the growth of Asparagus as resulting from a dressing of salt, except where manure has been used sparingly and in localities distant from the sea. A dressing, however, may be given in late March or early April, as it is useful against slugs and weeds; apply sufficient to make the soil appear white, or about a peck per rod. I have used it in March at the rate of half a peck per rod or 20 bushels per acre, and again in similar proportion after cutting, and this method is perhaps advisable, as salt lowers the temperature, therefore should not be given heavily in spring. It is, however, of little value as manure, and may be dispensed with where the contents of cesspools are used between the rows. The chief recommendation of salt is that of its being readily obtainable.

**NITRATE OF SODA.**—This is the best summer dressing that can be given, as it promotes quick and strong growth. It may be applied at the rate of 2 to 3 lbs. per rod, or 3 to 4 cwt. per acre, immediately after cutting ceases, the ground having been pointed over to get rid of the close surface occasioned by cutting, and it will readily be taken down by rain.

**SULPHATE OF AMMONIA** appears to act similarly to nitrate of soda, and may be applied in the same way and at the same time, using the same quantity.

**KELP.**—Containing soda and potash this ought to be useful, but I must put it in the same category with salt—viz., the Asparagus does not derive nearly so much benefit, if any, from an application of salt or kelp as from a dressing of seaweed; therefore we may conclude that salt and kelp are only useful as bases for the manufacture of nitrates, and that the value of nitrate of soda owes its value as manure to the nitric acid.

**SOOT.**—A valuable manure, most advantageously applied in June after cutting and pointing over. A peck per rod, 40 bushels per acre, is a good and sufficient dressing.

There are other substances that will be found useful, such as malt dust, which may be given an inch thick as a surface dressing in June and pointed in; “willy dust,” resulting of the tearing up of old woollen material by the “devil” in getting the stuff for mungo and shoddy, and rags. These are valuable manures, and may be dug into the ground in spring similar to manure. They are also of a slow decomposing and durable nature.

In naming so many substances it must not be understood that all are



to be applied to the same ground in one year, but they are mentioned so that each cultivator may utilise the means at his disposal. An example of the method of using the different substances as they obtain in different places will suffice to show what is intended. In a place where a dressing of manure has been given it will suffice to use the nitrate of soda in June, along with any of the other light dressings, the principal constituent of which is ammonia, such as fowl's dung, or soot. Where winter or early spring dressings of manure, night soil, blood composts, or seaweed are not given, then we may have recourse to the fowl's dung, soot, or malt dust in spring instead of in summer, or at both times, using the nitrate of soda at the time indicated, or it may be applied in spring when salt is not used, and it is much more efficacious as a slug destroyer. What is wanted is to utilise all available substances, and it is scarcely possible to give Asparagus too much support.

**MULCHING.**—In order to make the most of the manurial matter, and of the applications of liquid manure, whether from house sewage or stable and other tanks, a mulching of any loose material should be given about midsummer, or after the surface dressings in June. A mulch 2 or 3 inches thick of any partially decayed material is of great advantage in maintaining a moist condition of the soil, retaining manurial matter, and preventing the growth of weeds.

**STAKING.**—The haulm being strong is liable to damage from wind. To prevent that, put in stakes so as to be about 4 feet out of the ground and about 12 feet apart. Two lines of common tarband are run along so as to enclose the haulm, interlaced, but not wrapped round the stems. There should be a line of strings at about 2 feet 6 inches from the ground, and another near or at the top of the stakes. The strings allow the haulm to play with the wind, and this is better than close stiff staking and tying.—G. ABBEY.

(To be continued.)

## CULTURE OF THE AMARYLLIS.

Of late years no plant has been brought more prominently before the public than the subject of this note, and it deserves its position, for no class of plant has a more gorgeous appearance. Its culture is not at all difficult, but except in a few instances it is rarely seen in good condition. This may be through attempting to grow it in a mixed collection of plants and without bottom heat. Too much water is its greatest enemy, and plants are more likely to suffer through this when stood on a stage than when plunged. Our bulbs are now being grown in a pit, plunged over the pots in tan, and have a bottom heat of about 70°. They only require watering about every three weeks. The roots are running into the tan, and, this being fairly moist, they get all the nourishment they require. Ventilation is freely applied, and during the past bright weather shading has been necessary. In about another month or six weeks water will be entirely withheld and the plants encouraged to go to rest with freer ventilation. The temperature must not be allowed to fall below 45° during the winter months and the roots should be kept perfectly dry.

The middle to the end of February will be time enough to commence potting. The soil best adapted for the Amaryllis is six parts fibry loam, one part prepared horse manure, a half part of peat, with sufficient sand and pounded charcoal to keep the soil open. All the old soil will be shaken from the roots and care taken to pot very firmly. This must be particularly attended to, or failure will be certain.

Some growers are troubled with grubs attacking the base of the bulb; in this case the bulb should be thoroughly washed and care taken not to use cow manure or bone dust in the soil.

The best position for growing the plants is a low span-roofed house with a brick pit on each side and a walk down the centre. Tan is the best plunging medium, so the beds should be filled with this previous to the bulbs being potted. The bottom heat should range from 75° to 80°, and top heat 45° to 50°. If a higher top heat than this is allowed it will cause top growth in advance of root growth, while the opposite is what is required. The pots should be plunged right up to the rim, or if a little above it all the better, as it will keep the soil in a favourable state without water being necessary. It will probably be a month before water will be required, and afterwards about every ten days or a fortnight. It is astonishing how quickly the roots decay if over-watered.

As the growth advances increase the temperature and moisture about the path and shade from bright sun. As the spikes of bloom and foliage advance a slight syringing on warm days when the house is closed will be beneficial, but the house must not be closed too soon, as it would cause the spikes to "rush up"—an advance of 5° or so will be ample.

Whilst in bloom the plants may be removed to the conservatory, but as the blooms fade replunge the pots about an inch over the rim and treat as advised at the commencement of this paper. By the above it will be seen that the culture is very simple if the details are carefully carried out.—A. YOUNG.



## FRUIT FORCING.

**VINES.**—*Earliest Forc'd House.*—It is not necessary to wait until all the leaves have fallen before pruning matured Vines for early forcing, but the wood must be brown and hard and the leaves turning yellow. The pruning will cause the Vines to go more quickly and thoroughly to rest. If in good condition they will afford bunches quite large enough when pruned to a couple of buds from the base, but if the Vines are weak from overcropping or a long course of forcing, the spur shoots may be left a little longer with a view to larger bunches. When this method is adopted shoots should be taken from as near the base as possible in the spring, and should not be allowed to carry fruit, but be stopped at about the sixth leaf, and the laterals at the first leaf, and subsequently as produced. Such shoots are sure to form good buds; the extra foliage will tend to invigorate and support the fruit on the other shoot, which can be cut away in due time in favour of the other for fruiting the following season. This alternate system of fruiting necessitates the shoots being kept wider apart for development and exposure to light and air. If the Vines are grown on the extension system it will only be necessary to cut back to plump buds on firm ripe wood, being guided by the space at command, for there must not be overcropping. It is important that the house be thoroughly cleaned, and the Vines also. Any weakly Vines, or those in an unsatisfactory state, may be improved by removing the soil down to the roots and substituting fresh loam, with an admixture of crushed bones to the extent of about a twentieth, and if calcareous matter be wanting add from a sixth to a tenth of old mortar rubbish according to the character of the soil, more being required for heavy than for lighter soil. Lift any roots available for the purpose, laying them out upon the fresh compost, and cover 3 or 4 inches deep. This is best done before the fall of the leaf. It is a mistake to allow Vines when at rest to become very dry at the roots. Comparative dryness is desirable, yet great injury is caused by allowing the soil to become dust dry. The outside borders should have a covering of some kind to protect the roots from the heavy autumn rains, which reduce the temperature considerably. Glass lights are preferable, throwing off heavy rains while allowing the sun's heat to penetrate the soil. Many, however, are obliged to rest content with a covering of leaves and litter after cold weather sets in; and though convinced that good Grapes can be produced without material to throw off the rains, yet reason and practice justify their employment wherever available for the exclusion of moisture in undue proportion to the requirements of the Vines.

*Early Forcing Pot Vines.*—Those for starting in November must not be allowed to become dust dry at the roots. They will now be at rest, the wood ripe, the laterals cut close home, and the canes shortened to about 6 feet, more or less, according to the situation of the plump eyes. Whilst the cuts are dry dress them with styptic or knotting, to prevent trouble from bleeding. They should be kept in a cool, airy house.

*Young Vines.*—Those that have made a strong growth, and are late in ripening, should be assisted with fire heat, maintaining a minimum of 65°, and maximum of 75° from fire heat, continuing it until the wood is ripe, accompanied with free top and front ventilation. Discourage any further growth by the removal of the laterals as they appear.

*Late Grapes.*—Grapes, notwithstanding the heat that has prevailed since the early part of June, are not nearly finished in many instances, due, no doubt, to their having an unfavourable start, and late Grapes require plenty of time. Keep the laterals well thinned, and thereby admit as much light as possible to insure the finishing of the crop, not by large reductions of foliage at a time, but by frequent pinchings. Maintain a night temperature of 70° to 75°, falling 5° to 10° during the night, increasing 80° to 85° by day, accompanied with a free circulation of air, night and day. It will require sharp firing to finish off those that are only commencing colouring before the days are too short to admit of full ventilation; indeed, more may be done in the next four or six weeks than in twice the time later on. Those Grapes well advanced in ripening may have the atmospheric moisture reduced; those only colouring should have a moderate amount of moisture to assist their swelling, not neglecting to apply water to the inside border as may be necessary.

**CUCUMBERS.**—The shorter days and longer and colder nights necessitate the earlier closing of the house, and the employment of the syringe also earlier, so as to have the foliage fairly dry by dusk. Fire heat will also be necessary to maintain a temperature of 70° to 75° by artificial means, falling about 5° during the night. Afford every encouragement to the autumn fruiters, removing the first fruits and the male blossoms and tendrils. No shading will now be necessary, and avoid syringing as far as possible, damping being usually sufficient. Sow from now to the middle of the month for a supply of fruit at Christmas and the new year onwards. Telegraph is good for this, indeed for any sowing, while Cardiff Castle is free and excellent for everyday use.



**MELONS.**—The latest plants are fast covering the trellis and showing blossoms. If the crop is wanted quickly those early blossoms should be impregnated. A portion of the plants may have the first fruits removed, and they will afford a later and fuller crop from the second laterals. Earth up the plants after the fruit is set, not before, and after this be sparing of the syringe, employing it only during bright afternoons, and then early, taking care not to overwater at the roots, yet maintaining a genial moisture in the atmosphere by sprinkling; promote also healthy root action by proper moisture in the soil.

Plants in frames will require no water beyond occasional damping, and should only have moisture in the soil to keep the foliage fresh. Let the fruit be elevated above it on inverted flower pots, applying good linings to maintain the requisite heat, a warm, dry, and well ventilated atmosphere being essential to the well ripening of the crop.

#### PLANT HOUSES.

**Gardenias.**—Where house room is of great importance early in the season it is a good practice to grow the majority of these plants from cuttings annually for yielding flowers during the winter and spring. By this system the old plants, except a few for early autumn flowering, can be thrown out. Another advantage in having young plants is, that they grow under good treatment with greater vigour than old plants, and are therefore less liable to the attacks of insects. This is a good time to insert cuttings for next year's supply of plants. Select for this purpose the young wood of strong growing shoots. The cuttings should be inserted singly in 3-inch pots, in which the plants can remain during the winter. They will strike freely under handlights in a warm case if well watered after insertion and shaded from the sun. After the plants are well established grow them fully exposed to the light, and pinch the shoots as they extend from time to time. If potted early in the year, they will in the space of twelve months be fully 2 feet in diameter.

**Ixoras.**—If not already done, a large stock of these should now be rooted in 2-inch pots ready for transferring early in the year into others 2 and 3 inches larger. For the embellishment of the stove or dwelling house few flowering plants equal these for beauty. Sturdy cuttings of young wood should be selected. The softer the wood, the quicker they will be found to strike. They will root readily under the same conditions as Gardenias. As soon as they are rooted and show signs of growing, it should be determined whether the plants are to carry one or more trusses of bloom. If the latter, pinch them hard to induce them to push two or more shoots from near the base. It is a good plan to pinch a portion and allow the remainder to extend until they produce their truss. By this method a long succession of flowering plants is produced. If, however, a number of varieties are grown, they will not, without particular care, all flower at the same time.

**Clerodendron fragrans.**—A good number of these should also be rooted in 2 and 3-inch pots, and grown on a shelf close to the glass. If the roots are restricted in small pots every plant will produce its large compact truss of double white fragrant flowers during the winter, but if given liberal root room they continue to grow instead of flower. Place the whole of the cuttings in the pots in which they are intended to flower, and if the sizes named are used the plants will flower by the time they are 5 to 7 inches high. When the small pots become full of roots the growth will be slow, the wood firm, and flowers are certain to be produced on plants in this condition.

**Begonias.**—Such kinds as Ingrams, the varieties of nitida, Knowsleyana, and others intended to flower from November onwards, should be placed at once into 5-inch pots, or larger, as the case may be. Large pots for these plants are a great mistake, and the size named will be found large enough for all ordinary decorative purposes; in fact they flower better when confined at their roots than when grown in large pots. The plants provided for flowering at that period are invaluable, but a large stock of plants of nitida alba and rosea, Ingrams, sempervirens rosea, s. rubra, s. alba, and the free flowering Carrieri for flowering from the end of January or the early part of February are equally important in maintaining a continuous supply. These should be rooted at once and transferred afterwards into 2 and 3-inch pots, which will give them ample root room until the end of December or early part of the following month. These plants will then continue the supply until others are prepared to succeed them.

**Poinsettias and Euphorbias.**—These and other plants in cold frames of a like nature must be very carefully ventilated and attended to. If the frames are left open during one cold night the plants will be ruined. The temperature has already fallen very low, and to insure safety the frames should be closed early in the afternoon while the sun is upon them. If this is done the temperature about the plants will be several degrees warmer all night than if the frames are left open some hours longer.

**Campanulas.**—Place plants now in 6-inch pots of *C. pyramidalis*, and its white form into 10-inch pots, for flowering next season. Few plants are more beautiful when well grown for conservatory decoration. Seed should also be sown at once in a box, so that the young seedlings can be wintered in a frame and potted singly in spring. To grow these plants well a little seed should be sown towards the close of August every year. Lift large plants of *C. media calycanthema*, blue, white, and rose, and place them in pots according to their size, so that they will become well established before winter. These are beautiful indoors when brought forward by gentle forcing. Seed should also be

sown for another season's plants. These are perfectly hardy and may be sown outside.

## THE BEE-KEEPER.

### PRACTICAL BEE-KEEPING.—No. 17.

THE bee-keepers of to-day have been deprived of one of the greatest pleasures attendant upon the keeping of bees. The year when it was discovered how to take an artificial swarm marks an era in the history of bee-keeping, an epoch from which the management of the apiary was much facilitated but was shorn of one of its greatest charms. Those who have watched the issue of a swarm will realise the joy of the bee-keeper of past years, and estimate the loss suffered by the bee-keeper of to-day in his pursuit of gain. Even now it is necessary to discuss natural swarming in the interests of those who still allow their bees to swarm, or who are unable to prevent the issue of a swarm occasionally even when they desire no increase. Strong stocks in early districts will throw off natural swarms unless they are supered during the first ten days of May. There are several signs which betoken the issue of a swarm, and these are:

- 1, The presence of royal cells.
- 2, Unusual crowding at the entrance.

The stock will be filled from side to side with bees and brood in all stages of development and honey; the sweat trickles out of the hive in the early morning, the uproar in the hive is great, and sometimes large "grape-like clusters" of bees hang down outside the hive, work is partially suspended on the day of issue, and drones are unusually busy and fly fussing about anxious for the moment to arrive when the old home shall be deserted for a new shelter. Eggs are placed in the royal cells from four to five days before the issue of the swarm. If bad weather follows the queens may be nearly hatched before the bees are able to issue, and occasionally the young queens are destroyed and fresh cells constructed ready for a more favourable attempt when the weather shall be more propitious.

There are certain outward signs known to experienced bee-keepers by which they may know in the morning with some certainty whether a swarm will issue in the course of the day provided that the weather is suitable. If at ten o'clock, for instance, few bees are seen to leave the hive and fly away to the fields; if many bees are seen lying and crawling about the entrance, and the cluster grows larger instead of diminishing as the heat of the sun becomes more powerful; and if in addition to this drones are flying about in unusual numbers, a swarm may with confidence be expected; but if as the sun gains power the clustered bees disperse and the drones are not unusually active, it is most probable that no swarm will issue that day. If, then, the following symptoms are noticed a swarm may be expected to issue during the day:

- 1, Clusters at the entrance, increasing as the day advances.
- 2, Partial suspension of work.
- 3, Many drones flying about at ten o'clock and afterwards.

The time of issue is very uncertain. A swarm may issue any time during a fine day from six in the morning to six at night, but I should think that nine-tenths of the

swarms come out between eleven and three, and the vast majority between half-past twelve and two. The old queen which leads the swarm is rather particular about the weather, and will not come out unless everything is favourable. A very favourite time for a swarm is a close sultry day with gleams of sun occasionally, but certain days apparently alike have evidently a charm in the eyes of the queens; for to-day, which to all appearances seems the very day for a stock to swarm, not one will issue, while to-morrow, to all appearances the twin sister of to-day, every stock in the district will seem to have caught the swarming fever.

Here it may be said that a "swarm" is the surplus population led by the old queen; "casts," which may be one, two, three, or more in number, are the after-swarms led by young queens.

When a swarm has issued queen cells will be found containing either eggs or royal brood, which may, as I have remarked, be of various ages, this depending entirely upon whether or not the bees have been delayed by bad weather from issuing when they determined to colonise. When these princesses arrive at maturity, if the bee-keeper will listen at night, putting his ear close to the hive, he will hear curious sounds within, which various writers describe as resembling various sounds. Mr. Pettigrew wrote on this subject: "One of the princesses has come to maturity, and intimates her intention to claim the queendom of the hive. She calls 'Off, off, off,' which sounds like the barking of a dog at a distance. These sounds she repeats several times, and being unanswered she leaves her cell and becomes the rightful sovereign of the hive. She now commences to speak in another tongue altogether, uttering sounds more sharp and shrill. She calls 'Peep, peep, peep,' or rather 'Pa-ay, pa-ay, pa-ay,' eight or ten times. The other princesses answer and commence to bark 'off, off, off,' in their cells. This barking provokes the reigning queen very much." This goes on, the challenge and reply continuing for three days and three nights, and sometimes for a longer period; but on the fourth day after the piping begins the cast will generally issue, and it must not be forgotten that casts headed by their young queens will issue almost regardless of weather at any time during the day, early or late. When the cast has gone forth another princess is allowed to issue from her cell, and if again the challenge and reply is heard, another cast will issue the next day or next but one. Even yet the challenge and reply may again occasionally be heard, and if so another cast will issue the following day, but one swarm and two casts generally sufficiently depopulate the strongest stocks.

On one or more of the first four or five days after hiving a cast the young princess goes forth to meet the drone if the weather is favourable. Many queens are lost on these love excursions, and therefore attention is required to see that the queens become fertile, otherwise the casts will be ruined. If an accident does happen to a queen another must be at once supplied. The old stock is in the same danger, and must therefore also be carefully watched.

Swarms must be hived by holding a skep, bucket, or other convenient receptacle beneath them, and shaking or brushing the bees into it. Wherever the queen is the bees will congregate. If the queen is not secured the bees will return to her if they can find where she is, or they will return to the stock from which they issued. Sometimes casts have several queens, and the bees divide and cluster in separate places. They may be hived separately and then all joined together in one hive, no

precaution being necessary in uniting swarms if the operation is performed on the day of issue.

There are so many other points to be considered that it will be wise to defer the consideration of them until a future paper, when they may be discussed in detail, rather than to skim over them to-day, possibly missing some features which need special mention. We have treated of the signs of a swarm, the issue of a swarm, the signs of a cast, and the issue of casts, and the hiving of the swarms and casts; the fertilisation of the young queens, giving queen cells and accordingly lifting stocks, remain to be considered.—FELIX.

### BEEES AT THE MOORS.

SINCE the bees were taken to the Heather I have been part of the time enjoying myself amongst it at 2000 feet above sea level. The bees stand at 1000 above it, and fly over great tracts of the plains profuse in Heather to the former altitude, apparently richer in fragrance and honey than that lower down. As yet the weather has been changeable and not favourable for great honey gathering, especially with hives not in order for Heather work, but those that were have made considerable weight. The hive that I mentioned several weeks ago as having made upwards of 100 lbs. in a fortnight has again done well. Before taking it to the Heather I deprived it of 60 lbs. of honeycomb, and when I weighed it on the 16th August it had had only six working days since it was set down, but it weighed (bees and combs) 135 lbs., and while I write this on the 25th August its total making since the bees were put into an empty hive two months since is nearly 300 lbs. They are first-crossed Syrians. Space will not permit me to recount other extraordinary gatherings, which I hope to mention later. The country is the finest for bees I have witnessed, the hills for many miles being closely covered with Heather, and what adds to its quality is the many varieties of early and late flowering sorts. It is surprising that so few bee-keepers avail themselves of a district so rich in honey accessible to the bee-keepers, and as interesting as it is healthful.

Although the country presents no charms to the arboriculturist, being for miles without a tree, to the archæologist there is much to interest. Not far from our bees stands the castle where King James VI. invited the French and English noblemen to see the fruit that grew in his garden, and astonished them greatly when he showed them the basins full of sovereigns made from the gold gathered in the district, said to be £150,000 worth, a goodly sum in those days, and but a trifle I believe to what still lies underneath the Heath-clad hills.—A LANARKSHIRE BEE-KEEPER.

### MEAD.

"W. J. R." desires a recipe for making mead from any spare honey left in the combs. After all the honey has been pressed from the comb that will part lay the refuse in a vessel and cover with water, allowing it to steep until the honey is saturated and parts easily from the comb; now pass the whole through a fine sieve. If the liquor is not sweet enough add more honey. The strength is from 1 lb. to 2 lbs. honey to each gallon of water. We use no instrument nor measurement, but judge entirely by appearance. It is not unlike cream in consistency. It is then boiled gently for an hour or so, and carefully skimmed as the impurities rise. We then put in hops according to taste, and again pass all through a fine sieve, pour into a cooler, and when milkwarm add some yeast according to quantity and season. If the weather is favourable no yeast is required. When cool pour into a well-seasoned cask free from all mustiness—a wine or spirit cask is good, fill to the bung, and allow to ferment for several days, filling up the cask with some of the liquor preserved for that purpose as it goes down from fermentation, then bung up closely from six to twelve months. The liquor will be quite clear without clarifying if the spigot is high enough and drawn off without agitating the contents, but it will be none the worse for clarifying; it may be seasoned to taste before or after these operations, and if desired spirits of some sort may be added, though we never add any, but sometimes when fermentation has been strong a little loaf sugar improves it. If "Honey as Food and Medicine" be purchased from Messrs. G. Neighbour & Sons it will help and give a variety. Some people relish our mead, while others do not. For my own using I consider it superior and safer than some sorts of wines.—A. L. B.

DO BEES VISIT ONLY ONE KIND OF FLOWER IN ONE JOURNEY?  
—Is it a fact, as Aristotle ("Nat. Hist." ix. 40) seems to say (the Greek is somewhat ambiguous) that bees in collecting honey visit only one kind of flower in one journey, and do not go, for instance, from a Clover flower to a Scabious without first returning to the hive? I have no doubt the statement has been either verified or shown to be wrong, but I cannot find it mentioned.—C. W. D.

## TRADE CATALOGUES RECEIVED.

- Hogg & Wood, Coldstream.—*Catalogue of Bulbous Roots.*  
 W. B. Hartland, 24, Patrick Street, Cork.—*Little Book of Daffodils, &c.*  
 Robert Veitch & Sons, Exeter.—*Catalogue of Dutch Bulbs and other Flower Roots.*  
 William Bull, Chelsea.—*Catalogue of Bulbs and Tuberos-rooted Plants.*  
 Barr & Son, Covent Garden, W.C.—*Descriptive Illustrated Catalogue of Daffodils.*  
 Fisher, Son & Sibray, Handsworth, Sheffield.—*Catalogue of Bulbs and Winter-flowering Plants.*



All correspondence should be directed either to "THE EDITOR" or to "THE PUBLISHER." Letters addressed to Dr. Hogg or members of the staff often remain unopened unavoidably. We request that no one will write privately to any of our correspondents, as doing so subjects them to unjustifiable trouble and expense.

Correspondents should not mix up on the same sheet questions relating to Gardening and those on Bee subjects, and should never send more than two or three questions at once. All articles intended for insertion should be written on one side of the paper only. We cannot reply to questions through the post, and we do not undertake to return rejected communications.

**LATE INQUIRIES.**—It is necessary to again remind correspondents that letters arriving on WEDNESDAY MORNING cannot be answered in the "next issue," which is then far advanced for press.

**Book (E. J. Collis).**—In reply to your pleasant letter we have sent a book to your address, Norfolk City, Virginia, U.S.A. It may not contain everything you desire to know, but you will find in it much that is interesting and suggestive. The price is 3s. (three shillings) exclusive of postage.

**Sobralia macrantha (W. R.).**—You will find all the information you desire about this plant in our Orchid column in this week's issue.

**Insects (H. P.).**—Our entomologist states that the galls are certainly the production of the mite *Phytoptus Pyri*, but along the edges of some of the leaves are traces also of a fungoid growth.

**Destroying Earwigs (Mr. Howard).**—There is no better plan than to cut some Broad Bean stalks into 5 or 6-inch lengths, or the hollow stems of Sunflowers or Jerusalem Artichokes, avoiding the joints, so that the pieces have a hole right through them. They should be placed horizontally in different parts of the fruit trees, and be examined every day, and the earwigs blown out into sealding water. We find this plan very effectual.

**Fruit Tree for North-East and North-West Aspects (Y. H. J.).**—The north-east will be suitable for Cherries—Empress Eugenie, May Duke, and Governor Wood; for culinary purposes, Morello. Plums also succeed—Early Rivers, The Czar, Prince Englebert, and Victoria are suitable. The north-west wall would be available for Pears—such as Jargonelle, Williams' Bon Chrétien, Fondante d'Automne, Pitmaston Duchess, Durondeau, and Josephine de Malines. They should be on the free stock for high walls.

**Vine Leaves Withering (D. R. D.).**—We are not able to account satisfactorily for the shrinkage of the leafstalks. The composition of the border appears good, provided you have not used too much of Thomson's manure. It is excellent when instructions are followed, but they should not be departed from. The leaf sent is very small and destitute of tissue, and suggests that the atmosphere has been kept very moist. It is possible also there has been some error in ventilation. You very properly tell us how the border was made, but entirely omit the details of management as regards ventilation, syringing, damping, and temperature. We can only say that the leaf sent is for a main leaf not satisfactory, apart from the shrinkage of the stalk.

**Cape Gooseberry (M. D.).**—*Physalis edulis* or Cape Gooseberry is a half-hardy or greenhouse perennial, and requires to be grown in a greenhouse, or will succeed in a frame, or even outdoors in summer. We should shift the plants into 6-inch pots now, using good loam, with a fifth of well-decayed manure and a sixth of sharp sand well incorporated, and draining efficiently. Pot moderately firm, but not very hard, and supply water carefully until the plants are established, when freer watering is necessary, none being given until the soil becomes dry, but before the foliage flags, and then afford a thorough supply sufficient to show at the drainage. Keep the plants in the 6-inch pots during the winter in a light position, and afford the requisite support to the growth with stakes, or the growths may be trained to a trellis. The fruit is used for confections, some persons being very fond of the sweet acidulous flavour. It is of easy culture, and readily raised from seed. The plants may be shifted into larger pots in spring.

**Lifting Vines (Subscriber).**—Your method of lifting the Vine roots in the outside border is correct, care being taken to preserve all the roots possible and to keep them from the drying influences of the atmosphere by covering with damp mats. The roots emanate from the collar or a little below, so that those that go down are readily brought up. The border being removed see that the drains are in working order and the drainage clean and efficient. A foot of rubble—roughest at the bottom and smallest at the top—will be necessary for drainage, and over this put in a foot of

soil made tolerably firm, on which the lowest tier of roots can be laid, spreading them out evenly, and covering with soil about 6 inches thick. On that place another layer of roots, and cover with 3 or 4 inches of soil, and any smaller roots may form a third tier and be covered in like manner with not more than 3 or 4 inches of soil. The soil should be worked well in amongst the roots and made moderately firm. The work should be performed whilst the foliage is on the Vines, not deferring operations later than the leaves give indications of maturity. They may be shaded and syringed to prevent their quick shrivelling, and this will incite fresh root action.

**Gladiolus Colvilli and the Bulb Mite (T. S.).**—There is no doubt whatever about your bulbs being attacked by a form of the bulb mite, for the portions sent to us were swarming with the pest. The mites in question are larger than those that attack the *Eucharis*, although in appearance they are very much the same. We advise you strongly to burn the infested corms before the enemy reaches other bulbous plants in your garden. This is the most certain, and in the end the cheapest method of eradication. Are we right in supposing that the corms of *Gladiolus Colvilli* have been left in the ground during the winter for two or more seasons? A few years ago we left a number of *G. brenehleyensis* in the ground for two or three years, and at first the plan succeeded so well that we were warranted in treating the whole of our stock in the same way, with the result that nearly all the corms were attacked the same as those you have sent. We dug up and burned the whole of them, and have not since been troubled with this destructive pest. For a few seasons we did not plant the fresh corms obtained nor any other kinds of bulbs on the same ground. The *Gladiolus* "disease" is, we suspect, caused by the ravages of this mite. Our experience convinces us that a change of corms is important, and a change of site as well. The mite on the corms sent can be seen with the naked eye, but those that attack the *Eucharis* are scarcely distinguishable without the aid of a glass.

**Lifting Vines (J. D.).**—You have not followed any instructions of ours in the use of "dung under and round the roots;" you have, indeed, departed from the advice contained in the very reply to which you refer. The roots being outside and in we did not advise the renovation of both borders at once, and much the safer plan would have been to lift the roots outside, and place them in fresh soil, with due provision for drainage, treating the inside roots and border similarly the following year. This method of renovation has been advised repeatedly both by ourselves and by gardeners who have found it satisfactory. You have, however, acted differently, and we hope the Vines will improve. Nor did we tell you to "put a bushel of quicklime to the square yard on the top of the border for forking in when slacked." If you have used sufficient old mortar in the border, you had better remove nearly all the lime, and place on a covering of half-decayed manure, leaving it to decay. How you could fork a bushel of lime into each square yard of a border in which the roots of Vines have been recently disposed without injuring those roots, passes our comprehension. The roots you sent were quite dead; but we have no means of knowing whether they were in that state when cut off; nor can we form an opinion as to whether the Vines will "come round" or not. We can only say for your encouragement that Vines endure a good deal of rough and curious treatment before they succumb.

**Mushrooms in Pastures (H. H. C.).**—It is useless "sowing" spawn at any time, and unless the soil and season should be specially favourable it is by no means certain that a good crop of Mushrooms would follow the insertion of the spawn in a new pasture. In Wright's "Mushrooms for the Million," the following instructions are given by a famous grower, Mr. Barter:—"Manure should be prepared as if to be made into a bed, and when it is in the right condition remove squares of turf the size of a spade and about 3 inches deep, taking out at the same time sufficient soil to admit of a large forkful of manure. In the centre of this place a quarter of a brick of good spawn, and tread the whole in firmly, replacing the turf at once, and beating it down so that it is hard and level as before removal. At any time from the middle of May to the middle of June will be suitable for doing this, as at that time the temperature of the earth is usually sufficient to incite the growth of the mycelium, while at the same time the requisite degrees of moisture is generally provided. A very good index of this, however, will be afforded by the state of the turf. Should the grass show any sign of dying it must be watered carefully, giving just sufficient for keeping the grass green. The most suitable pastures for Mushrooms are those where the turf is old and the earth a mass of fibrous roots, the soil of medium texture, and the subsoil porous. In pastures of this kind one spawning would probably suffice, as the mycelium would become established in the roots of the grass, except, perhaps, during an unusually wet season. In view of this contingency it is well to choose slight elevations rather than hollows or depressions in the pasture, and it is advisable also to have the prepared places as close together as possible, even if spawn is not inserted in all of them at the same time. Mushrooms grow freely in light soil, but if plentiful are usually small. In heavy soils where the subsoil is not porous it would probably be necessary to insert spawn every year. The Mushrooms, however, would generally be much heavier than in light land, and perhaps more than repay the difference in the cost incurred by the yearly spawning. Meadows which are naturally wet, and districts where the rainfall is great, cannot be expected to give a satisfactory return for the outlay incurred in labour and material for accomplishing the work in question. It is impossible to explain precisely and in an intelligible manner the pastures that are adapted for Mushrooms or the reverse, but the point can be determined by a few well-conducted experiments on the lines above indicated."

**Gathering and Storing Fruit (A New Subscriber).**—Many kinds of Apples and Pears are not ripe till long after it is the proper time to gather them. As a general rule they are fit to gather when the seeds are black or brownish black, and also when the stalk separates, on the fruit being raised from the pendulous to a horizontal position, at the junction of the stalk and spur, as the petiole of a leaf separates at its base. If the stalk require twisting and force, and would rather break in the middle than at this point, the fruit is not tired of the tree, and is unfit to gather. There are, however, some exceptions to this general rule. We may usefully mention Williams' Bon Chrétien and the Flemish Beauty—two excellent Pears if gathered before they readily part from the tree, but otherwise they both become dry and disagreeably musky. Early ripening



Apples and Pears require to be carefully watched so as to gather them at the right moment. Some of them are best eaten from the tree, and none of them will keep long; when their freshness is gone so is their flavour. The keeping of Apples and Pears requires considerable care and attention. Various modes have been adopted in various situations. Some keep their fruit in winter in cellars or caves below ground; others in lofts or the most elevated rooms in buildings. Some dispose them in single layers; others in heaps. They have been kept in sand, chaff, kiln-dried straw, dried fern, and in powdered charcoal. The latter substance is good, as it absorbs bad gases, the product of decay. Chaff is objectionable, and every other substance that like it engenders a musty taste. Dried fern answers very well, and so does thoroughly dried Wheat straw. Whichever mode be adopted, the following principles should be kept in mind:—1, as regards temperature; 2, moisture; 3, ventilation. Moisture is greatly affected by temperature. If a goblet of very cold water is brought into a warm room the glass becomes wet by the condensation of moisture. If a cold Apple or Pear is brought into warm air, or if warm air is introduced to the cold fruit, the latter will become wet from the same cause. So long as the fruit and air are of the same temperature no deposition takes place. In frosty weather fruit becomes cold, and when a thaw sets in, accompanied with a warm south-west wind, Apples and Pears are seen quite wet from condensation. This, of course, affects their sound keeping; hence the necessity of avoiding vicissitudes of temperature. Warm air should be excluded when the fruit is cold, or only admitted gradually, taking the opportunity of doing so when the external air is dry. A fruit room should be dry, and its temperature not liable to be affected by sudden changes. One in which the fruit kept exceedingly well was not large. It was fitted up with shelves, on which the fruit was laid on clean-drawn straw. It was a loft over a coach house, so that the cool air circulated below the floor. The walls were lined with wood, so as to leave a half-inch cavity between the wooden lining and the wall, and the roof had a double ceiling. Thus enclosed by non-conducting materials, no sudden changes of temperature took great effect on the fruit, for a night's frost did not alter the thermometer one degree. The room was kept dark. In this place beautiful Marie Louise Pears were kept in good condition till Christmas. Ventilation should be given when the air of the room is not pure; but this should be done at the warmest period of the day, when the external and internal temperature correspond as nearly as possible. A steady temperature in a dry situation is the main point to be attended to in keeping fruit. Where a regularly constructed fruit room is not at command Apples and Pears may be kept very well in baskets lined with dry straw, and put in a cool place, unless some Pears be required for any occasion earlier than usual; then, by bringing them in a basket well packed in dry soil into a warm place—say 60°, they will soon become fit. The straw would be better kiln-dried.

**Names of Fruits.**—The names and addresses of senders of fruit to be named must in all cases be enclosed with the specimens, whether letters referring to the fruit are sent by post or not. The names are not necessarily required for publication, initials sufficing for that. Only six specimens can be named at once, and beyond that number cannot be preserved. (R.P.S.)—1, Red Astrachan; 2, Yorkshire Greening; 3, Stirling Castle; 4, Fearn's Pippin.

**Names of Plants.**—We only undertake to name species of plants, not varieties that have originated from seed and termed florists' flowers. Flowering specimens are necessary of flowering plants, and Fern fronds should bear spores. Specimens should arrive in a fresh state in firm boxes. Slightly damp moss or soft green leaves form the best packing, dry cotton wool the worst. Not more than six specimens can be named at once. (J. McGrath).—The name of your Orchid is *Camaridium ochroleucum*, (M. D.).—The plant is an *Asclepias*, perhaps *A. curassavica*, but the scrap is too withered for us to be positive on the point. (W. H. K.).—The name of the Orchid is *Catasetum integerrimum*. (H. C.).—1, *Epilobium angustifolium*; 2, *Hyacinthus candicans*; 3, *Helianthus multiflorus*; 4, *Sedum glaucum*; 5, *Chrysanthemum maximum*. (L. S. E.).—1, *Oenothera speciosa*; 2, *Veronica spicata*. 3, *Eucomis punctata*. (Jarvis).—1, *Veronica Traversi*; 2, *Hydrangea paniculata*; 3, *Hypericum calycinum*; 4, *Oxalis corniculata rubra*. (Mrs. Lord).—1, *Pteris tremula*; 2, *Lastrea dilatata*; 3, *Asplenium marinum*; 4, *Selaginella caesia*. (R. Weller).—*Aranja* (*Schubertia*) *grandiflora*.

COVENT GARDEN MARKET.—AUGUST 31ST.

BUSINESS steady down, with good supplies of all classes of fruit.

FRUIT.			
	s. d.	s. d.	
Apples, ½ sieve .. ..	1 6	to 3 6	
Nova Scotia and			
Canada barrel .. ..	0 0	0 0	
Cherries, ½ sieve .. ..	0 0	0 0	
Cobs, 100 lbs. .. ..	0 0	0 0	
Figs, dozen .. ..	1 6	2 0	
Grapes, per lb. .. ..	0 6	2 6	
Lemons, case .. ..	10 0	15 0	
Melon, each .. ..	2 0	3 0	
Oranges, per 100 .. ..	s. d.	s. d.	
Peaches, dozen .. ..	6 0	to 12 0	
Pears, dozen .. ..	2 0	6 0	
Pine Apples, English,	1 0	1 6	
per lb. .. ..	1 6	0 0	
Plums, ½ sieve .. ..	3 0	4 6	
St. Michael Pine, each	3 0	6 0	
Strawberries, per lb. ..	0 0	0 0	
VEGETABLES.			
	s. d.	s. d.	
Artichokes, dozen .. ..	1 0	to 2 0	
Asparagus, bundle .. ..	0 0	0 0	
Beans, Kidney, per lb. ..	0 3	0 0	
Beet, Red, dozen .. ..	1 0	2 0	
Broccoli, bundle .. ..	0 0	0 0	
Brussels Sprouts, ½ sieve	0 0	0 0	
Cabbage, dozen .. ..	1 6	0 0	
Capsicum, per 100 .. ..	1 6	2 0	
Carrots, bunch .. ..	0 4	0 0	
Cauliflowers, dozen .. ..	3 0	4 0	
Celery, bundle .. ..	1 6	2 0	
Coleworts, doz. bunches	2 0	4 0	
Cucumbers, each .. ..	0 4	0 6	
Endive, dozen .. ..	1 0	2 0	
Herbs, bunch .. ..	0 2	0 0	
Leeks, bunch .. ..	0 3	0 4	
Lettuce, dozen .. ..	s. d.	s. d.	
Mushrooms, panna .. ..	0 9	to 0 0	
Mustard and Cress, punt.	0 2	0 6	
Onions, bunch .. ..	0 3	0 6	
Parsley, dozen bunches ..	2 0	5 0	
Parsnips, dozen .. ..	1 0	0 0	
Potatoes, per cwt. .. ..	4 0	5 0	
" Kidney, per cwt. ..	4 0	0 0	
Rhubarb, bundle .. ..	0 2	0 0	
Salsafy, bundle .. ..	1 0	1 6	
Scorzoner, bundle .. ..	1 6	0 0	
Seakale, basket .. ..	0 0	0 0	
Shallots, per lb. .. ..	0 5	0 0	
Spinach, bushel .. ..	3 0	4 0	
Tomatoes, per lb. .. ..	0 4	0 6	
Turnips, bunch .. ..	0 4	0 6	

PLANTS IN POTS.			
	s. d.	s. d.	
Aralia Sieboldi, dozen ..	6 0	to 12 0	
Arbor vitae (golden) dozen	0 0	9 0	
" (common), dozen ..	0 0	0 0	
Ascers, dozen pots .. ..	8 0	6 0	
Azalea, dozen .. ..	0 0	0 0	
Begonias, dozen .. ..	4 0	9 0	
Calceolaria, dozen .. ..	3 6	8 0	
Cineraria, dozen .. ..	0 0	0 0	
Creeping Jenny, dozen ..	0 0	0 0	
Dracana terminalis, doz.	30 0	60 0	
" viridis, dozen .. ..	12 0	24 0	
Erica, various, dozen .. ..	0 0	0 0	
Euonymus, in var., dozen	6 0	18 0	
Evergreens, in var., dozen	6 0	24 0	
Ferns, in variety, dozen	4 0	18 0	
Ficus elastica, each .. ..	1 6	7 0	
Foliage Plants, var., each	2 0	10 0	
Fuchsia, dozen .. ..	s. d.	s. d.	
Geranium (Ivy), dozen ..	3 0	to 9 0	
" Triolor, dozen .. ..	3 0	6 0	
Gladiolus .. ..	4 0	6 0	
Hydrangea, dozen .. ..	9 0	12 0	
Lilies Valley, dozen .. ..	0 0	0 0	
Lilium lancifolium, doz.	12 0	18 0	
" longiflorum, doz.	0 0	0 0	
Lobelia, dozen .. ..	0 0	0 0	
Marguerite Daisy, dozen	6 0	12 0	
Mignonette, dozen .. ..	3 0	6 0	
Musk, dozen .. ..	2 0	4 0	
Myrtles, dozen .. ..	6 0	12 0	
Palms, in var., each .. ..	2 6	21 0	
Pelargoniums, dozen .. ..	6 0	12 0	
" scarlet, doz.	3 0	9 0	
Spiraea, dozen .. ..	0 0	0 0	
CUT FLOWERS.			
	s. d.	s. d.	
Ahutilons, 12 bunches ..	2 0	to 4 0	
Anemones, 12 bunches ..	0 0	0 0	
Arum Lilies, 12 blooms ..	3 0	6 0	
Asters, 12 bunches .. ..	5 0	6 0	
" French, bunch .. ..	1 6	2 0	
Azalea, 12 sprays .. ..	0 0	0 0	
Bluebells, 12 bunches ..	0 0	0 0	
Bouvardias, bunch .. ..	0 8	1 0	
Camellias, blooms .. ..	0 0	0 0	
Carnations, 12 blooms ..	1 0	2 0	
" 12 bunches .. ..	4 0	6 0	
Cornflower, 12 bunches ..	1 6	3 0	
Dahlia, 12 bunches .. ..	3 0	6 0	
Daisies, 12 bunches .. ..	2 0	4 0	
Encharis, dozen .. ..	4 0	6 0	
Gardenias, 12 blooms ..	2 0	5 0	
Gladiolus, 12 sprays .. ..	1 0	1 6	
Hyacinths, Roman, 12			
" sprays .. ..	0 0	0 0	
Iris, 12 bunches .. ..	0 0	0 0	
Lapageria, white, 12			
" blooms .. ..	0 0	0 0	
Lapageria, coloured, 12			
" blooms .. ..	1 0	1 6	
Lilac (white), French,			
" bunch .. ..	0 0	0 0	
Lilium longiflorum, 12			
" blooms .. ..	2 0	4 0	
Lilium lancifolium, 12			
" blooms .. ..	1 6	3 0	
Lilies, White, 12 bunches	0 0	to 0 0	
" Orange, 12 bunches	0 0	0 0	
Lily of Valley, 12 sprays	0 0	0 0	
" 12 bunches	0 0	0 0	
Marguerites, 12 bunches	2 0	6 0	
Mignonette, 12 bunches	1 0	3 0	
Myosotis, 12 bunches ..	2 0	3 0	
Narciss, 12 bunches .. ..	0 0	0 0	
" White, English, hch.	0 0	0 0	
Pansies, 12 bunches .. ..	0 0	0 0	
Pears, Sweet, 12 bunches ..	3 0	6 0	
Pelargoniums, 12 trusses	0 9	1 0	
" scarlet, 12 trusses	0 3	0 6	
Pinks, White, 12 bunches	0 0	0 0	
" various, 12 bunch	2 0	4 0	
Peony, 12 bunches .. ..	0 0	0 0	
Poinsettia, 12 blooms ..	0 0	0 0	
Primula (single), bunch ..	0 0	0 0	
" (double), bunch .. ..	0 9	1 0	
Polyantus, 12 bunches ..	0 0	0 0	
Ranunculus, 12 bunches	0 0	0 0	
Roses, 12 bunches .. ..	2 0	6 0	
" (indoor), dozen .. ..	0 9	1 0	
" Tea, dozen .. ..	1 6	3 0	
" red dozen .. ..	0 0	0 0	
" de Moix, 12 bunches	0 0	0 0	
Stephanotis, 12 sprays ..	2 6	4 0	
Tropeolum, 12 bunches ..	0 0	0 0	
Tuberose, 12 blooms .. ..	0 6	1 0	
Tulips, dozen blooms ..	0 0	0 0	



GREEN CROPS.

YOUNG layers have suffered so severely from the effects of the drought that on many farms much of the plant is dead, and many old Clover layers will be kept over for another year. This is altogether contrary to custom, both Red and White Clover being treated as biennials and ploughed in for a corn crop after the second year. The intention of many farmers to leave them for another year has given rise to much discussion about the matter, and we have heard more than one good farmer assert that it will not answer to do so. Like most positive assertions this is not altogether correct, for there can be no doubt that some old layers will answer well enough while others will prove a partial or entire failure. A little common sense will show how this will happen. If a layer is on heavy land that is badly drained or in a low damp situation, the plant is likely to suffer so much from frost next winter that much of it will die and the layer be spoilt; but if on light land or mixed soil that is well drained, and in a tolerably elevated position, the layer is unlikely to suffer from frost and to answer well another year. To insure a really vigorous growth it must have a liberal dressing of manure, either of home-mixed chemicals or of wood ashes saturated with sewage or urine from cattle yards, early next spring before active growth begins.

There can be no doubt that the very general prevalence of drought throughout the country will induce more than the usual attention to making some provision of green crops for next spring and summer. Such crops are

often termed catch crops, as though they were the outcome of chance, of a fitful opportunity—something stolen from the soil, and not a regular or legitimate crop; yet there never was a season when such crops were not wanted, and they are certainly worthy of a place in the regular routine of farm crops every year. To take them in the order of sowing, we should sow White Mustard and Rape at once for a supply of late autumn food, and the Cattle Cabbage sown in seed beds early in August should be transplanted as fast as the land can be got ready for them, for they will afford an invaluable supply of green food early next summer, which in its season is almost as useful as that sown early last spring and now in use. A few hours before sitting down to write this article we saw some excellent practice on the farm of a wealthy yeoman, and among other signs of sound practice were two covered cattle yards well stocked with a herd of polled Suffolks in the enjoyment of perfect shelter and care. They are never turned out to graze on pasture, but are fed in the yards on a mixed diet, which now consists principally of chaff and Cabbage. Other green food is used in season, so as to impart a wholesome change to the dietary, while the cattle are never exposed to inclement weather and are not worried by flies. Cattle so cared for encounter none of the trying vicissitudes which the wretched animals purchased at fairs and markets have to undergo. They never lose their calf byre, but are always in superlative condition during an existence that is a virtual embodiment of true economy in its avoidance of waste of tissue, and therefore of time and money. In twenty months, or at most in two years, they are ripe for the butcher; and although the early development may seem to partake somewhat of a high pressure system, it is in reality not so. We have seen young cattle forced into a gross plethoric condition by the injudicious use of corn, cake, and linseed, that heavy losses from quarter evil have followed; but by a regular and judicious use of green food all risk of such loss is avoided.

Winter Tares sown in September and October follow the Rye Grass in spring. We are not particular as what crop winter Tares are sown after, but we try to have them in a well drained or upland field in sound fertile soil. We like to continue folding the ewes and late lambs on Tares after they have taken late Turnips, Rye and Rye Grass, Lucerne or Sainfoin. There should also be an abundant supply of Tares for horses and cattle, not only from crops sown in autumn, but also from successional crops of spring Tares. This would appear so self-evident that mention of it is uncalled for; but we regret to say that by far too little attention is given to the due provision of such crops, and yet they may be had in the heat of summer when pastures are burnt and parched, if only sowings are made frequently enough to maintain a full supply. In southern counties they should not be sown till the end of September or beginning of October, for if sown earlier growth is apt to become so forward as to suffer from cold and wet during winter.

WORK ON THE HOME FARM.

Now is the time when more and better work can be done in cleaning the land than at any other period of the year. Not a day should be lost when the stubbles are cleared, and the fallen corn has been gleaned, to break them up with whatever implement appears best adapted for the purpose. It is true that some soil is still so hard that extra strong tackle is required to enter it; it is in such cases that steam power proves invaluable. But we hold that deep ploughing of foul stubble is altogether a mistake at this season of the year. For example, we have some fields badly infested with Charloek. To plough them deeply now would be to store the land with Charloek seed for years to come. We shall therefore at first only stir the surface to a depth of 2 or 3 inches, or just enough to induce the speedy germination of Charloek seed which autumnal showers are certain to induce. We shall thus get rid of most

of it, and deep ploughing can follow at our leisure. Stubbles foul with couch grass will be pared with broadshare ploughs, and harrows will follow at once to clear off as much of the grass as possible. This work can only be done before much heavy rain falls, hence the importance of turning every hour of fine weather to account now.

Deep ploughing of clean land for Wheat, winter Oats, Rye, and winter Tares should have attention as soon as possible, and due preparation be made for sowing winter corn before the weather becomes so broken as to hinder or spoil the work. It never answers to sow Wheat when the surface is so wet that the seed cannot be covered by harrowing. Upon our heavy land farm we hope to be able to sow early, for owing to the failure of the Swede and white Turnip crop there we shall make our first Wheat sowings upon that part of the farm, and follow upon land where sheep are now folded upon Red Clover. Both the Turnip land and Clover layer will be well stored with manure, and by using carefully selected seeds we hope to insure a fine Wheat crop next season. White Wheat has answered so well with us this year that we shall sow a much larger area of it this autumn. It is equally hardy as any of the Red Wheats, yields quite as well, and certainly commands a higher price per quarter, which after all is the most important test.

THE HESSIAN FLY AND ITS ENEMIES.

It has been pointed out earlier in the history of the present visitation of Hessian fly that this obnoxious insect has other than human enemies. Professor Fream has lately placed in glass bottles some sections of Wheat and Barley straw containing the "flax-seeds" or puparia of the Hessian fly, in order to obtain in due time the perfect insect. In one case there emerged from the chrysalis, instead of the expected fly, a small four-winged insect, which was recognised as being of the same species (Semistellus Destructor) as that which the United States Entomological Commission of 1880-2 reported on as the chief natural enemy of the Hessian fly, an enemy so powerful as in certain years to keep its ravages wholly within bounds. It appears that this insect pierces the sheath of the stalk, and deposits a minute egg in the pupa of the Hessian fly which is there concealed. The egg gives rise to a larva of its own, which devours the interior of the Hessian fly pupa, reducing it to a mere shell or casing, within which it matures itself, finally eating its way through case and leaf sheath, and emerging to carry on its work anew. Professor Fream questions, on the strength of the discovery that this formidable parasite has accompanied its host to these shores, whether it is after all good policy to burn the stubble and destroy the flax-seed, since in doing so we shall at the same time destroy our little allies who are temporarily ensconced in some of them. Our endeavour, he says, should be to encourage the natural foes of the fly to the very fullest extent. Since we cannot do this without abandoning our efforts to destroy the healthy "flax-seed" also, the advice comes very near to a recommendation to stay artificial attempts at repression, and leave the parasite to deal with the fly for us in the natural course of things. We last week observed that it was beginning to be suggested that perhaps the fly was, after all, not so new an importation as is generally imagined, and it may be that Professor Fream's little four-winged protégé has been for years keeping the fly in check for us, doing good by stealth. Lord Walsingham, who is an accomplished entomologist, remarks that in the last thirty years 670 species of beetles, butterflies, and moths have been added to the list of British insects, and that in the year 1886 alone one observer added to the list of flies or diptera no less than 100 distinct species not hitherto recorded as British. It is, as he says, impossible to believe that any large proportion of these are newly introduced or imported. The majority of them, no doubt, have merely escaped earlier observation, and nearly all of them must be more conspicuous than the Hessian fly. Miss Ormerod's supposition, made known long ago, that the fly has been sent to us in straw litter from abroad has received recent confirmation by fresh discoveries of Hessian fly pupæ amongst other miscellaneous vermin in foreign litter. Since this litter, from various sources, is converted into dung in the stables and cowsheds of London, Liverpool, Hull, Bristol, Glasgow, and other seaports, which dung is distributed in thousands of tons throughout the country, it becomes, as Mr. Martin Sutton pointed out a few days ago, clear that if the Hessian fly could be stamped out to-day, the whole country might be infected again next year.—(Daily News).

METEOROLOGICAL OBSERVATIONS.

CAMDEN SQUARE, LONDON.

Lat. 51° 32' 40" N.; Long. 0° 8' 0" W.; Altitude, 111 feet.

DATE.	9 A.M.					IN THE DAY.				Rain	
	Baromet. at 32 and Level.	Hygrometer.		Direction of Wind.	Temp. of soil at 1 foot.	Shade Temperature.		Radiation Temperature.			
		Dry.	Wet.			Max.	Min.	In sun.	On grass.		
1887.		deg.	deg.	deg.	deg.	deg.	deg.	deg.	deg.	In.	
August.	Inches.										
Sunday .....	21	30.111	59.9	54.5	S.W.	59.4	76.2	47.0	114.8	45.7	—
Monday .....	22	30.133	60.4	54.6	S.W.	59.3	75.2	45.4	119.5	44.7	—
Tuesday .....	23	30.112	63.9	55.0	S.W.	60.2	75.4	46.6	107.4	43.8	—
Wednesday ..	24	30.014	67.9	59.8	E.	60.6	76.9	52.2	110.6	44.4	—
Thursday .....	25	29.937	62.1	59.8	Calm.	61.2	82.0	51.4	117.0	49.8	—
Friday .....	26	29.798	68.7	62.0	S.E.	61.9	77.2	52.5	110.9	49.6	0.034
Saturday .....	27	29.813	62.2	59.8	S.	62.1	74.7	50.4	113.9	53.7	0.010
		29.983	63.6	57.9		60.7	75.9	50.5	113.4	48.7	0.074

REMARKS

21st.—Fine and generally bright.  
 22nd.—Bright and fresh.  
 23rd.—Clear and fine in morning; hazy in afternoon.  
 24th.—Close and rather hazy, otherwise fine.  
 25th.—Foggy till about 11.30, then warm with a good deal of sunshine.  
 26th.—Dull, with slight rain in afternoon.  
 27th.—Dull morning, with spots of rain; fair afternoon.  
 Fine generally, and again warm, being about 3° above the average.—G. J. SIMONS.



## COMING EVENTS

8	TH	
9	F	
10	S	
11	SUN	14TH SUNDAY AFTER TRINITY.
12	M	
13	TU	
14	W	

Royal Horticultural Society—Fruit and Floral Committees at 11 A.M.  
National Chrysanthemum Society's Show, Westminster.

### DEEP VERSUS SHALLOW CULTIVATION.

**I**T may well be asked before the season of drought passes out of memory, What advantage is there in deeply cultivated soil as compared with that which is cultivated in a shallow manner? I believe the advantages are many, but what strikes one most is the slight hold the dry weather takes on vegetation established in deeply worked fertile soil. Naturally deep-rooting trees like Apples are greatly improved in the quality of their produce. Currants of all kinds have borne enormous crops of fine fruit which has been sweeter than is general, even in good seasons. Deep-rooting vegetables, of which Peas are an example, have been alike remarkable for their general healthiness and for the large crops of fine quality they have produced. Taking Dahlias as presenting a good type of deeply rooting plants, we find these to be very floriferous, the foliage healthy and the flowers large. Shrubs growing in deep soil have gone on in a perfectly satisfactory manner; those growing in shallow ground have been severely punished. Of course there are many plants which delight in a dry warm medium, but these we do not refer to, for we find Dahlias in soil of slight depth dried up and flowerless, Peas yellow and incapable of producing any pods, and Apple trees stunted, fruit small and falling prematurely. The reason for these things is to be found in the one case in the soil containing a sufficient amount of moisture to enable deep-rooting plants to supply themselves with a liberal quantity of food to carry out all the processes of their existence beneficially. But with shallow-worked ground the stratum of fertile soil must have been so thoroughly freed from moisture as to cripple the plants by lack of food, and very probably those roots which did pass beyond the reach of the drought were in a medium entirely deficient in the elements of plant food, of which moisture itself is only one, though most important.

There is another point worth calling attention to, and that is the greater capacity thoroughly well-worked soil has for retaining moisture. This fact points to the necessity of cultivators not only turning over ground to a fairly good depth, and incorporating, if possible, manure throughout; but further than that all clods and lumps of soil must be well broken up to its entire depth, this process rendering the ground of a greater staying quality in such periods of dry weather as we have this year experienced than that which has been merely roughly trenched and clods left unbroken. That such is the case is proved by mounds of fertile soil, such for example as the banks between Celery trenches, being more productive in very dry weather than even ground on the level. We refer of course to broad mounds of soil.

Proceeding to consider the case of plants which do not require a deep rooting medium, and to which therefore it may be thought the drift of these remarks does not apply, it may be here pointed out that a deep body of soil in good fertile condition exerts throughout its whole depth an influence on the plants growing therein. Rapid-growing plants, such as Cabbages, summer Cauliflowers, Philoxes, Asters, and annuals generally, one-year-old Strawberries, &c., do not root deeply, and any manure which it may be considered necessary to apply to the soil as a direct help should not be applied deeper than 9 to 12 inches; but if the soil is worked no deeper at any time than the above figures such crops will cut but a sorry figure in dry weather, whereas on a deeply cultivated soil under proper management most of them will succeed well. The reason is to be found in the fact that, although the roots of the plants may not travel deep enough to obtain direct supplies from the deeper soil, yet there is a continual passing of moisture laden with plant food in solution to take the place of the drier medium in which the roots are active. If there be no means of staying the upward progress of this moisture its final destination will be the atmosphere, and much of its value is destroyed by this means. However, a layer of pulverised dry soil formed on the surface of the ground by means of hoeing acts as a very complete foil between the dry atmosphere above and the comparatively moist soil beneath.

No doubt also plants growing in deep soils have time to adapt themselves to the circumstances of their life. The environments of animals exert a powerful influence on their habits and capacities to exist under very differing conditions. Plants exercise this peculiarity in a greatly enhanced degree, and it is wonderful to see how plants are capable of extracting support from soil which to all appearance is of a very dry nature. There is a limit to this, but it is much sooner arrived at in the case of a shallow cultivated soil than with a deep one.

The great benefit derived from adding to the depth of fertile soil by the addition of material added to it from outside sources, such as soil, decayed garden rubbish, and so forth, has been clearly shown this year. We have instances of poor shallow soil which has not yet been improved by any such additions, and others where deep dressings have been given, and the difference in the two is measured by success in the latter case, and failure in the other. There are gardeners wealthy in the sense of procuring at their wish the best of everything, who would hesitate to add anything of a poorer quality than good loam to their garden soil; but decayed vegetables, leaves, sweepings of roads, and soils which have been used and left to lie by for a year or two are quite as effective in many cases as loam. At any rate, no one need hesitate to employ these who may wish in vain for the other—B.

### BEDDING VIOLAS.

It may interest not a few growers of these plants to know how they have behaved during the present summer, also the conditions under which they have existed, and what varieties have succeeded or failed, as the case may be, under such conditions. The strain upon the durability of these and many other hardy flowers is entirely without precedent, and only those that have been well cared for in the planting season will have borne the exceptionally severe test to which they have been subjected. It would be difficult to conceive times more trying than the past few months, so that with all these



overcome it is only fair to assume that we may in future grow *Violas* with a full measure of success even in southern counties. The cultural details which I shall presently briefly give are for the most part intended to meet the wants of those who experience difficulty in growing them successfully, and here I may remark that few plants are more beautiful than *Violas* when well grown, and few which present a more miserable and wretched appearance when only half cultivated.

The particulars of my culture, then, is briefly this. Firstly, bastard trench the ground and dig in wet green cow manure abundantly—this is the only secret in this direction. The whole of my beds were turned up about 20 inches deep, working in as much manure as I could. In one of my beds, consequent upon a hint thrown out by Mr. Baxter of Daldowie last year, I worked in a quantity of ground lime, the result of which I will hereafter note. This was hardly Mr. Baxter's advice, for if memory serves me aright that gentleman advised lime water to be given to any plants which might exhibit signs of going off. I viewed this hint carefully, for I had a good list of plants going off suddenly and without warning, and was anxious to find something to prevent it if possible, but instead of giving lime water to diseased *Violas* I preferred to try a preventive of the disease. I not only worked in much lime in digging, but scattered some over the rough surface and had it raked in. I selected my weakly varieties and such as had exhibited a tendency to dying off in this unaccountable manner to be the occupants of this bed, and I am happy to say the result is successful beyond my expectations, and especially so when we consider the great drought of this Jubilee year. I thank Mr. Baxter for his hint about lime, even if I have not closely followed him in his mode of application.

Last autumn in planting I renewed an old practice of mine of planting in deep drills, and which I shall continue in all future plantings. Its benefits are twofold; first, it enables the operator to earth up his plants and so induce them to form tufts of young shoots about their base, and secondly, in the summer waterings the water is conveyed directly to the roots of the plants. But methinks I hear voices saying, "Of what use is such doctrine as this to owners of small gardens where the beds have raised centres?" I furnish the answer and say, Not the slightest. But there is no law compelling any person to have his or her flower beds raised in the centre, so that instead of being 9 inches or a foot high let the bed be level, and if situate upon the grass let it be 2 inches below the turf—*i.e.*, the surface of the bed prior to planting. By adopting this method you will be paving the road to success with one of the most pleasing and attractive, as well as varied and profuse flowering groups among bedding plants. The advantage of planting *Violas* in sunken beds instead of raised beds will, I think, be obvious, and especially does this apply to cases where the soil is light, stony, or resting on gravelly subsoils.

There is a wealth of beauty among these plants only at present known to a few, and no group of hardy plants is deserving of more general culture. As there is much difference in the general habit and constitution of these plants it may not be out of place to detail briefly a few facts respecting them, placing the varieties in order of merit and in their respective colours.

#### WHITE-FLOWERED VARIETIES.

*Countess of Hopetoun*.—Without hesitation I give this the first place. Flowers large, well-formed, and handsome; a pure milk-white self; very dwarf and compact; good constitution; free and

continuous bloomer; blooms retaining their original size to the last. On an almost equal footing I place *Lady Polwarth*.

*Pilrig Park*.—This is a good second; fine constitution; free and profuse bloomer; maintaining all its original popularity.

*Jeffreyana*.—Remarkable for its early flowering, its freedom and general good habit. It is dwarf; the flowers lose size with time.

*Mrs. Gray*.—I would fain have given this a better position among whites. It is wonderfully free-flowering and fragrant; enduring constitution; somewhat loose habit; the flowers almost always splashed with lilac blue.

*Champion*.—The champion of the whites in size; but only useful as a spring bedder, for which purpose it is grand.

#### YELLOWS.

*Ardwell Gem*.—My continued experience of this compels me to give this the first place. Colour, light canary; splendid both in form of flowers and constitution; a wonderfully free and continuous bloomer; dwarf; flowers supported on long stalks, and every bloom perfect. It has kept the same character throughout, and always covered with flowers.

*Bullion*.—Golden; a good bedder and free bloomer; good constitution; the thin somewhat straggling habit leaving abundant room for improvement.

*Brilliant* I place next, not on account of its superior form, for this it lacks, but for its long-continued flowering; it occupies the lime bed, and has flowered continually since February last.

*Golden Queen of Spring*.—This is one of the greatest successes in the lime bed, and hitherto a precarious doer; but I have not lost a plant this year. The constitution is much improved, and the flowering continuous, though at present the flowers are much reduced in size. It is a dwarf in habit; a gold canary coloured self.

#### LAVENDER.

*Elegans* is a very good representative in this section; very free and continuous; good habit and constitution.

#### LILAC.

*Queen of Lilacs* here stands alone and is a grand plant in all respects; free, dwarf, early, continuous, and of good constitution.

#### PURPLE CRIMSON.

*Queen of Purples*.—A grand variety, dwarf, compact, and very free to the last.

*Cliveden Purple compacta*.—A compact form of that well-known variety, robust habit and very free.

#### DARK VIOLET BLUE.

*Archie Grant*.—A magnificent variety of splendid habit and constitution, very profuse, and having richly coloured flowers.

*Holyrood*.—A grand variety, especially well suited for summer and autumn blooming.

#### VIOLET PURPLE.

*Mrs. Charles Turner*.—This is another unique member, and certainly a grand and telling *Viola* all round. Sturdy, dwarf habit, excellent constitution, very free and a continuous bloomer. It is also remarkable for its distinct colour.

#### MISCELLANEOUS.

*York and Lancaster*.—A fancy *Viola*, the flowers being lighter in summer than in spring. I had this from Mr. Baxter last year with a wonderful recommendation, but it has proved identical with one which I had from Mr. Dean as *Columbine*. It is a very pretty plant and an effective bedder, and a fairly good constitution.

*Dawn of Day* I also had from Daldowie. It is an exquisite shade of cerulean blue on a white ground, the latter being netted and veined with the former in a remarkable manner. A grand grower.

*Skylark*, also from Mr. Baxter, is a grand stamp for constitution and dwarf habit, in which particulars it is excellent. It lacks freedom, however, and is not constant. It is white, and in spring has a charming Picotee edge of sky blue; this vanishes, however, in a week or two.

*Countess of Kintore*, with its purple steel blue and white flowers, is very good and a universal favourite. No doubt it will long remain so, unless a dwarfer habited variety in the same way comes before it.

*Lord Darnley*.—This is a grand variety, but a complete failure with me. It only did poorly last year, and it failed with me some three years ago very similarly, and I do not think I shall try it again.

The foregoing are my observations during the present year. They are given with a view of assisting those who

are on the alert for first-class varieties, but if I were compelled to grow only half a dozen I would unhesitatingly select Countess of Hopetown, Ardwell Gem, Archie Grant, Mrs. Chas. Turner, Elegans, and Queen of Lilacs; each and all of these are of sterling merit, possessing sound constitution, are of good habit, and withal free and abundant bloomers.—E. JENKINS.

### METHODS OF KEEPING GRAPES.

GRAPES are now ripe, or nearly so, in many houses, and the owners not unnaturally desire to know how best to preserve them for as long time as possible. To sell them, as many try to do, is almost out of the question, customers worthy of the name being few and far between. The markets are glutted with inferior produce, and this spoils, for the time being, the sale of good fruit. It must then be almost given away, or be kept, either for home use, or the markets, as long as can be accomplished.

A long spell of exceptionally hot and dry weather has not only compensated for the time lost earlier in the year when so little progress was made, owing to the uncongenial weather, but it has, or ought to have, well ripened the fruit. The experienced gardener knows that heat with a good circulation of dry air is necessary to insure the formation of the saccharine matter, without which Grapes will not keep for any length of time, and acts accordingly. On dull sunless days a little fire heat is employed, whereas the novice or careless cultivator is content to let matters take their course. Closed ventilators and plenty of moisture in the house, perhaps given to a number of pot plants of no great value, but yet persistently kept under the Vines, is altogether unsuitable for ripening fruit. Sour watery Grapes usually result from this treatment, and mildew is oftentimes most abundant and destructive. Continue that system well into September, and many of the Grapes will decay, and no wonder.

At the present time there are thousands of small vinerias and greenhouses well stocked with Grapes, and if these could be kept till November, or later, if the sorts are suitable, they would afford much pleasure to the owners. Seeing that the early sorts, such as Black Hamburgh, Madresfield Court, Foster's Seedling, and Buckland Sweetwater are ripened so well, there is every reason to anticipate better success than usual in keeping them. Conditions favourable to ripening the fruit are equally necessary for preserving it. There must be a free circulation of air in the daytime, and both top and bottom lights ought to be slightly open during the night. If it is necessary to close the top lights when heavy rains are falling, these must again be opened directly rain ceases and the sun appears. If this precaution of re-opening is neglected, or if the top ventilators are not opened as soon as the sun reaches the house in the morning, the air soon becomes heated, and moisture condenses on the colder Grapes. If not seen in time, and the house well ventilated, the moisture collected on the berries trickles off, carrying with it much of the bloom. Moreover, this "sweating," as some term it, has the effect of softening the skins of the berries, and an early decay sets in. Plenty have wondered why their Grapes kept so badly, and I have given them one very frequent cause.

Now for another. Wasps are very fond of Grapes, and if not checked soon play havoc with a crop. Some attempt to keep them out of the house with the aid of canvas, muslin, or other kind of rather closely woven material, while others prefer to enclose the bunches in muslin bags. Both plans are successful as far as the wasps are concerned, but as any material capable of excluding wasps also excludes much air, the remedy may easily be worse than the complaint. I found it so whenever I tried the plan, and not a few Grape growers have opened their muslin bags only to find a mass of mould and decay inside. In our warm, yet rather moist climate, we find it necessary to have the doors, as well as all the ventilators, wide open, the openings being covered with fish nets, in order to shut out the birds. Whenever wasps put in appearance, a few of the berries eaten are coated with a small quantity of Davis's Wasp Destroyer. Incredible as it may appear, and as it did seem to me before I tried it, this remarkable mixture soon clears the house of wasps. A few are poisoned, the rest take the hint, and clear out as rapidly as they can, nor do any trouble us again for a few days.

If there are plants unavoidably kept in a house where Grapes are ripe, these ought always to be watered in the morning soon after the ventilators are opened, taking care not to slop water about needlessly. On dull showery days watering should be dispensed as far as possible, and this may often be safely done for several days in the case of plants in a shady house. The

outer atmosphere being very moist, the fire should be lit, and the warmed pipes or flues will maintain a drier or more buoyant atmosphere, and be the means of saving many bunches. It is in the daytime, when the ventilators are open, that these fires are of most service.

In some cases, those in charge of small vinerias and greenhouses containing Grapes are bound to utilise these places to their fullest extent for housing a great variety of plants when frosts are anticipated. The preceding remarks will have made it tolerably plain that when this happens the Grapes will not long keep in the same house. Fortunately, if properly ripened, they may be bottled, and if stored in a dry airy room and properly looked after, will keep plump and good for a long time. Soda and seltzer water bottles, or any of medium size with a fairly large neck, are suitable for this purpose. These should be suspended with strings from a rail of some kind, and partially filled with clear water. The bunches must be cut with a sufficiently long piece of wood attached to admit of this reaching well down into the bottle. Any medium-sized, or two small bunches in one bottle, will bring the latter into a sloping direction, the Grapes thus swinging nearly clear of the bottle. Not caring to cut so much of the lateral growth away so early in the year, we frequently cut nearly close to the bunch, and insert into the bottles the wood formed beyond the bunch. This answers quite as well as the plan of inserting the thickest end. The leaves being still fresh and green, it is advisable to preserve one or two about the bunch, these serving to attract the water from the bottle and keeping the berries plumper. This is especially advisable in the case of Grapes cut early, say in order to preserve their colour or freshness till they are wanted for a special purpose. It is almost needless to add that the bottles should be kept sufficiently filled with water, but on no account, however, should this be overdone, as water trickled through a close bunch proves fatal. The bunches, whether kept in a room, or left hanging on the Vines, ought to be almost daily looked over, and every bad berry found carefully cut out. If left a few hours pressed among other berries, the whole of them will soon become a mass of decay. Neglect of this precaution is also another fertile cause of the loss of many bunches. Cold currents of air should also be excluded, though if it is a question of cold air or a stagnant atmosphere, by all means choose the former.—W. IGGULDEN.

### A POTATO TRIAL.

WE have planted a considerable variety of Potatoes here this season, and with a view to selecting a few of those most suitable for our purpose I had one shaw of each of the following sorts dug up and weighed to-day, September 3rd, and as the weights vary considerably, they may be of interest to some of your readers.

Village Blacksmith stands at the top of the class with 5 lbs. 8 ozs., or something like 45 tons to the imperial acre, for they are planted in drills 2 feet apart and nearly 1 foot in the row. Next comes a red Potato, name unknown, with 4 lbs. 12 ozs., followed by White Elephant with 4 lbs. 7 ozs., Yates's Early Emperor with 4 lbs., Beauty of Hebron 3 lbs. 12 ozs., Yates's Stirling Castle 3 lbs. 9 ozs., Rintoul's Early White Don 3 lbs. 9 ozs., Yates's Early Prolific belied its name with 1 lb. 12 ozs., Yates's Early Improved 1 lb. 9 ozs.

The varieties we mean to retain are Village Blacksmith, Early Emperor, Beauty of Hebron, the red Potato, and Rintoul's Early White Don. These are grand varieties both as croppers and for table. The soil they are grown on is light and gravelly. They had no farmyard manure, and as the season was very dry they are perhaps not such a heavy crop as they would have been had they got more rain. On the other hand, they are perfectly free from disease, and their quality is of the very highest order. With much rain no doubt more or less of the disease would have made its appearance.—WM. THOMSON, Clovenfords.

P.S.—Not over 1 lb. weight of the whole are so small as to be unfit for table, nor are any of them too large, except White Elephant.—W. T.

### HOLLYHOCKS.

I WAS pleased to read the remarks of "W. D." (page 155) on this truly noble flower. The Hollyhock is certainly coming to the front again, but slowly. In reading the different accounts of shows reported in the Journal, very little mention indeed is made of Hollyhocks. I would suggest that if nurserymen could be induced to give special prizes at local shows in their respective districts for say six or twelve blooms, we would soon have a strong competition, and competitors would no doubt patronise such firms. Mr. Blundell seems to be an extensive grower, but "W. D." seems to think his flowers are not quite equal to those seen in the "old Hollyhock days." I had my collection from Mr. John Downie, and they are quite up to anything we had twelve or fourteen years ago, when I used to grow them more extensively. I have still a few of his old varieties which have stood the severe winters all these years. The only protection they have is a little river sand put about them, and a few branches put over them during the severe weather. The Hollyhock likes a good dry ground, and I am sure well repay any

care or protection they may require. I am also pleased to notice that several gardeners in my district (Cornhill-on-Tweed) are doing their best to bring the Hollyhock to the front again.—G. STEEL.

## HOLIDAY IN THE SOUTH.

(Continued from page 135.)

PASSING along at the top of the sea cliffs from Ventnor *via* Collins Point and High Port to Horseshoe Bay, Bonchurch, I was very much struck by the quantity of Samphire (*Crithmum maritimum*) that is now growing there. Some twenty-five or thirty years ago it was very rare indeed to see a plant of this within reaching distance of the top of the cliffs, for at that time there was such a great demand for it for pickling purposes, men used to ply their dangerous trade of Samphire gatherers by fixing a crowbar firmly in the earth at the top of the cliff and letting themselves down by means of a rope and gathering it from the face of the precipice. Perhaps the extensive manufacturing of other pickles by large firms has brought them more within reach of the consumer that less trouble is taken over home-made pickles than formerly. To those unacquainted with Samphire I may say that it is a bright green fleshy plant, growing about 6 to 9 inches high, very much resembling some of the round-leaved Mesembryanthemums, and has a peculiar brisk, pungent taste. Judging by the advertisements of a firm of soap manufacturers, there seems to be another use in store for it; possibly someone has discovered that it possesses saponaceous as well as caustic properties.

Proceeding along the cliffs we reach Dunnose Point, a very high headland next the sea, and rising some 770 feet above it—a well-known landmark to the shipping and mercantile trade. We stop to admire the shady groves and bright hotels of Shanklin, and make a slight halt at Sandown, to enjoy a tempting walk on the broad sands that stretch around the bay. From Sandown we find ourselves at Brading on our way to St. Helens and Bembridge. There are many things of interest in the old ancient town of Brading. The bull ring at the cross roads, and the antiquated stocks under the old Town Hall, serve as a reminder of the march of civilisation. St. Helens and Bembridge are two seaside resorts, situated on the opposite sides of the now contracted St. Helens Harbour. The whole surroundings within this last ten years have been completely transformed. We travelled thither in a railway over the very spot where twenty-five years ago we sailed in a race for a silver cup. It is a secluded part of the island, and fast rising in popular estimation. Bembridge is very shady and enjoyable. The Ducie avenue of overhanging trees forms a pleasant promenade. St. Helens Duvur, or Dover, is especially interesting on account of the beautiful and somewhat rare plants found growing thereon. This is a strip of land that stretches out and forms one of the arms of Brading Harbour, and composed almost entirely of sand that has been washed and drifted up from time immemorial, it is covered entirely with vegetation peculiar to this soil. It was here we had the pleasure of meeting a friend whose successful career that should act as a stimulus to all young rising gardeners, to whom the pages of the Journal are always open for friendly advice and encouragement. Once a practical horticulturist and a frequent contributor to your pages, he has risen by his own energy and ability in the social scale to be an alderman of a large borough town and a J.P. We found the love of his profession still in his heart, and he is always ready for a friendly chat that never fails to be both interesting and amusing.

We take a stroll on the Duvur to have a look at a lovely patch of the Great Sea Bindweed, *Calystegia Soldanella*, that is growing there. It spreads and trails over the sands, and twines about amongst the Rushes and Grasses, bearing a profusion of large pink *Convolvulus* like flowers quite 2½ or 3 inches in diameter. The Sea Holly, *Eryngium maritimum*, is another object of interest here. It is quite indigenous to the place. Its quaint-looking silver-grey branches being brightened up by blue heads of Teazle-like flowers. The common Thrift, or Sea Pink, *Armeria vulgaris*, grows everywhere, and forms part of the ordinary turf. At the end of the Duvur farthest from the harbour stands an interesting object, being a portion of what was once the parish church of St. Helens. All that remains now is the west door and belfry tower, the rest being washed into the sea about a century ago, the remaining wall being kept whitened and used as a landmark by the Admiralty.

The sight of this encroachment set us thinking to what extent the Isle of Wight is gradually wasting away by the inroads of the sea, and although it does not appear much from year to year, yet, if anyone visits it after a few years' absence, a great difference is at once seen. The footpaths around the coasts have fallen into the sea many times in the last twenty-five years, and although thousands of pounds have been spent in sea defences—at the east of the island at all events—they have mostly proved ineffectual. At Seaview the walls have been washed away, and the trees and grass fields are gradually slipping down in great masses. Bonchurch old church, previously mentioned, was once, they say, in the centre of the parish, now it is within a stone's throw of the seashore. Anyone, therefore, who endeavours to make up for the loss by reclaiming land from the sea deserves both praise and success. This has been done by the Brading Harbour Company. The task was previously attempted some years ago by Sir Hugh Middleton, the New River celebrity. It is now an accomplished fact. Some 700 acres of Brading Harbour, which formerly at high water was like a vast lake, and at low water a field of mud, have been reclaimed by the Company by shutting out the sea with a bank, on the top of which is a carriage

road running from St. Helens to Bembridge, and which forms the present boundary of St. Helens Harbour. Although only commenced about ten years ago, so complete is the reclamation that it now looks green and cheerful. On the land crops of all kinds of cereals have been grown. Although the whole is gradually being laid for permanent pasture, and sheep and cattle grazing at the present time, part of it is retained as a kitchen garden, which produces an abundance of every kind of vegetables for the supply of the two hotels belonging to the Company. Plantations are flourishing, some of the trees being 10 or 12 feet high. Around the road, which is a level mile, Gorse and Broom have been sown, forming a thick sheltering hedge, which looks beautiful when in bloom. There are 2¼ miles of railway on the land, with the two stations, St. Helens and Bembridge, large quays with steam cranes for the accommodation of the heavy traffic have been erected. Not the least interesting is the oyster breeding ponds, which are here very successful. To anyone interested in reclamation works apart from the other attractions, the place is well worth a visit, and would receive, we are sure, a ready welcome at the hands of the energetic manager.

Leaving by rail to Newport, *via* Brading and Sandown, we notice in the water meadows at Alverstone large quantities of the wild yellow Iris in flower, and many inquiries were made by our fellow travellers respecting the same. At Newport, the capital of the island, we make a halt. To those who are that way inclined the church of St. Thomas should be visited. Situated in an open and spacious square, it has a lofty, clean, and noble appearance, and inside it is adorned with the ancient tablets and memorials preserved from the old church at time of rebuilding. One erected by our present Queen to the memory of Princess Elizabeth, King Charles's ill-fated daughter, who died at Carisbrooke Castle, and was buried here, is very touching and beautiful. It represents her in marble, a full length figure, with her hands crossed, and her head resting on the pages of an open Bible, a position she was found in when she died. We pay a visit to Newport Nursery, to our friend Mr. Edward Cave, who is ever ready to welcome any friends of the craft that pass that way. This claims to be the original establishment of the kind in the Isle of Wight, and has branch establishments at Shide and St. Thomas's Square, conducted by his sons. There is a great demand from these southern nurseries for Sweet Bays, old plants of which seed freely about here, and the young ones raised from the berries, *Euonymus*, *Aucubas*, *Arbutus*, *Evergreen Oaks*, *Laurustinus*, &c. The range of span-roofed houses at the entrance are replete with the usual stove and greenhouse furnishing plants; but special mention must be made of a house of Maidenhair Ferns, which forms a groundwork to Palms, the whole having a pleasing appearance. There is also a small collection of Orchids in the stove with other plants. A collection of Chrysanthemums reminded that these plants are being grown more about the island since the two Chrysanthemum societies were started at Ryde and Newport respectively. Outside in the borders we noticed a little gem in flower that is not very much known. It is a dwarf crimson, very double Sweet William, a good grower, and very attractive and showy. We avail ourselves of the opportunity offered by our friends to take a drive around the country between Newport and Ryde.

We make a short stay at Haven Street and call at Longford House, the seat of J. Rylands, Esq., a compact and neat place, overlooking woodlands and pastures. The gardener, Mr. Barkham, is noted for his collection of Chrysanthemums, and also for the general excellence of the other things under his charge. In that we were not disappointed. Zonal Pelargoniums of the leading single and semi-double varieties were very good and likely to make a display throughout the early winter months. There is a lofty and spacious conservatory attached to the mansion very gay with well grown plants of *Coleus*, *Fuchsias*, *Pelargoniums*, *Liliums*, *Celosias*, &c., intermixed with healthy Ferns and Palms. A large collection of Chrysanthemums is being grown in pots in the kitchen garden. They are grown in a bush form to suit the place, and will, no doubt, make a good display in due season. Mr. Barkham is a disciple of Mr. Molyneux through his writings, as evidenced by a couple of plants that had been grafted with three or four different kinds. All the scions had taken and were growing well at the time of our visit. This was Mr. Barkham's first attempt, the process being adopted as detailed in Mr. Molyneux's book—a proof of its practical teaching. We made a note of some plants of *Primula sinensis*, *alba magnifica*, and other varieties that had had their day, and were now standing out. As some of the largest we had ever seen, they were in 10-inch pots, and measured 2 feet to 2 feet 6 inches across. "Too large to be useful," no doubt many will say. So they are for the majority of purposes, but here there was a place for them. I had been advocating small pots for *Primula* cultivation, confining the roots, and feeding, and should associate damping off and stagnation with cultivation in this size pots, so this was a knock down blow. Truly there are exceptions to every rule. We pass on, and notice as we drive through the imposing square building, comprising a Working Men's Institute, Library, and Coffee Rooms erected by Mr. Rylands for the benefit of the village. Through Bloodstone Copse to Wootton Bridge is a real country drive; passing over the creek we soon get to the Osborne estate, the entrances to which looked trim and neat, and evidently ready for Her Majesty's reception. At Whippingham Church we stop, and being kindly offered to be shown in to admire, as we did, the very beautiful tablets and memorials erected and so closely connected with our Royal Family. We push on down through East Cowes, crossing the ferry, and on through West Cowes, and on to Egypt, thence to Parkhurst, and home to Newport—a very enjoyable drive.

Before I close with this ramble in the Island I must mention Caris-



brook, and advise all who can to walk up to that very pretty village and inspect the historical Castle, and should the weather be favourable the view from the keep of the Castle is alone worth the exertion. Instead of returning by the village take the path at the back of the Castle, and cross over the lane to the next hill to the cemetery, and through that, over the hill called Mount Joy, into Newport, via Slide and Node Hill. The view from Mount Joy, on a fine summer's eve, is a beautiful landscape with the river Medina running through the centre to the Solent at Cowes, and right and left the waters of the Solent that divides the island from the main land. The celebrated view from Richmond Hill is not to be compared with this for beauty and variety.—C. A.

#### HYDRANGEA STELLATA FLORE PLENO.

SEVERAL Hydrangeas have taken a place amongst the best of decorative plants, such as the old *H. hortensis* and the more recent *H. pani-*

*Hydrangea* well, and it can be satisfactorily grown in any greenhouse or similar cool structure.

#### THOMSON'S VINE MANURE.

IN your very judicious reply to "D. R. D.," whose Vine leaves seem to have withered, you give a caution against the excessive use of our manure, which is wise in itself; at the same time, perhaps you will let us say that even if he had trebled the dose we recommend, no evil but much good to his Vines, all else being right, would have been the result. Last year we doubled the dose we recommend, and we have trebled it this year, and the result is that we have three tons more Grapes on the same Vines than ever we had before. Perhaps you will allow these remarks to appear, as your caution may alarm some of those who use the manure.—WM. THOMSON & SONS.

[We should be sorry to alarm anyone, but we have seen so much



Fig. 26.—HYDRANGEA STELLATA FLORE PLENO.

*culata grandiflora*, the latter though hardy having become most valuable as a pot plant for forcing. The one represented in the woodcut, fig. 26, however, *H. stellata flore-pleno*, is not so well known, though it is a very distinct and beautiful plant when well grown, and is useful in pots for conservatory-decoration. It was shown a short time since at South Kensington by Messrs. J. Veitch & Sons, Chelsea, and the plants, though small, proved its value for ornamental purposes, as the heads of bright pink star-like flowers are produced very freely. As young plants are so profuse this increases their usefulness greatly, as in small pots they have a pretty effect arranged with Ferns or other light-foliage plants.

A compost of light turfy loam and peat in equal parts suits this

injury result from the excessive use of manures which are good when rightly used, that we deem it prudent to give advice that so far as we know is safe, and we do not feel justified in advising the inexperienced to depart from the directions of vendors either of manures or insecticides. The instructions of Messrs. Thomson are now enlarged, and for the very substantial reason indicated.]

#### THE ROYAL HORTICULTURAL SOCIETY—REPORT OF THE PRIMULA CONFERENCE.

IN your issue of the 1st inst. I observe that one of your correspondents asks if the reports of the Primula and Narcissus Conferences can be obtained, and speaks of the offering of the Pear Report to the Fellows

as a new departure on the part of the Council. Will you allow me to state in your columns that as yet no report of the Narcissus Conference has been published, but that a copy of the report on the Primula Conference was sent to every Fellow of the Society without exception? If your correspondent be a Fellow and failed to receive a copy, he need only have sent a postcard addressed to the Secretary, and another would immediately have been sent him. If he is not a Fellow he could have procured a copy on payment from Messrs. Macmillan & Co., who for some time past have had all the Society's publications on sale. It may be assumed under these circumstances, I think, that your correspondent's failure was in consequence of his not having tried very hard to obtain the work.—EDMUND BAX, *Assistant Secretary R.H.S.*



A LIMITED number of packets of SEEDS FROM SIKKIM are now ready for distribution to Fellows of the Royal Horticultural Society and lists can be had on application to the Assistant Secretary at South Kensington.

— THE STORMS AND FRUIT CROPS.—The late storms have had a disastrous effect on the fruit crops in various districts, in some instances practically all the fruit being dashed from the trees.

— THE list of rules and regulations of the GARDENERS' ORPHAN FUND has just been issued, and contains in addition the report of the first general meeting on July 12th this year, together with lists of subscribers and donors, and the names of officials connected with the fund.

— MR. J. HIAM says he has given up Bean stalks as EARWIG TRAPS years ago in favour of Hemlock stalks cut into lengths of 18 inches without joints, and consequently they hold so many more carwigs. On the 5th inst. he caught over 900 in his orchard and garden.

— DEATH TO WASPS.—Mr. G. F. Warren writes:—"Having tried the new insecticide—'death to wasps'—with satisfactory results, I recommend it to all 'brothers in the craft' who are troubled with those enemies among their fruit. This insecticide is a powder sold in tin boxes with instructions for use, which are simple. A 3s. 6d. box is calculated to be sufficient to destroy thirty nests." It is advertised in the Journal.

— THE YORK CHRYSANTHEMUM SHOW opens on November 16th, and continues for three days. Among the prizes we notice two silver cups, one given by the Lord Mayor of York for a group of plants, the other by the City Sheriff for thirty-six cut blooms. Messrs. Wood and Sons offer a silver Jubilee medal for trained plants; and in the fruit classes a timepiece is offered for six bunches of Grapes in three varieties, this being given by the Vice-Presidents and Stewards of the Ancient Society of York Florists.

— WE are desired to state that on Thursday in last week fifty of the *employés* of MESSRS. W. CUTBUSH & SONS of Highgate, Finchley, and Barnet Nurseries went for their annual excursion, the place chosen being Brighton. They were accompanied by Mr. Herbert J. Cutbush, Mr. W. Easton, foreman at Barnet, Mr. R. Reid, foreman at Finchley, and Messrs. J. Hawker, J. Reed, and T. Snewing, foremen at Highgate. After visiting several places of interest they dined at the Grand Concert Hall Restaurant. "Success to the Firm," coupled with the health of the head of the firm, was proposed by Mr. T. Snewing. Mr. H. J. Cutbush responded. Various other toasts followed, and the day's excursion was a complete success.

— THE WAKEFIELD PAXTON SOCIETY.—At the ordinary weekly meeting of the members of the above Society, held on Saturday evening, Mr. J. P. Carter of the Paxton Nursery, Cowick, read a capital and thoroughly practical paper on "The Tomato." Mr. Carter dealt with the question of cultivating the Tomato from a market gardener's point of view, and recommended his fellow gardeners to grow it on the single stem or Vine system. He exhibited some very fine specimens.

— MR. F. A. FAWKES, Chelmsford (author of "Hot-Water Heat-

ing"), offers the following HINTS TO AMATEURS ON HEATING GREENHOUSES:—"Those of us who want warmth during the next winter in our hitherto unheated greenhouses are now beginning to consider how we can do this in the cheapest, easiest, and most efficient manner. I have thought that a few hints to those who know but little about a heating apparatus would be serviceable. I need not say that of course a proper hot-water apparatus is the most advantageous, and these are now made so cheaply and in forms so easily fixed by any amateur that they are within the means of anyone who possesses a greenhouse. It would naturally be invidious for me to select any particular make when there are so many good ones in the market; but it will save an intended purchaser a great deal of unnecessary correspondence and trouble if, when he applies to a manufacturer for prices, he will also say what he intends to heat; give a rough ground plan of his greenhouse, figuring the inside-length, and width; indicate the position of doorways; say whether it is a lean-to or span; give heights to eaves and ridge; and say what he wants to grow. The manufacturer will then be in a far better position to recommend what he considers most suitable, and to show the best arrangement of pipes."

— MR. G. HAWKINS, Ewenny Priory Gardens, Bridgend, an excellent cultivator of FRUIT TREES IN POTS, writes:—"I have this day sent per parcels post a spray of Plums, Belgian Purple, with seventeen fruits on. The tree is in an 18-inch pot, and for the last twelve years it has not missed bearing a heavy crop. This year it has over 300 fruits on. I consider it is one of the best Plums we have for pot culture. It is good either for dessert or the kitchen. I think you will find the fruit a fair size and well coloured, although the crop is great." Many of the fruits were smashed in transit, but those uninjured were of full size, well coloured, and in every respect excellent.

— MR. JUPP, gardener to Cuthbert Johnson, Esq., briefly describes his practice of growing WINTER ONIONS as follows:—"Sow two good seeds a foot apart in good soil; let the plants remain till spring; then draw one out in each case and the other will grow very strong, White-Elephant developing bulbs 6 inches across."

— "JUVENIS" sends the following NOTES ON PEAS AND CARROTS:—"The recent dry weather has shown, without a doubt, the great advantages attendant on sowing Peas deeply. Those that were sown in the orthodox manner have long since succumbed to the drought, while those sown very deep and covered with a layer of Mushroom bed refuse have passed through the ordeal quite unharmed, without either watering or mulching. With us the Carrots this year have not been attacked with maggots as in former seasons. Last year we sowed a few rows among the spring-sown Onions, and they grew to a very large size and were quite clean. This year we repeated the experiment with like happy results. It must in a certain measure be due to the hardness of the soil required for the Onions, as when they are sown in the ordinarily prepared soil they soon go bad. We have also grown a very fine crop of Carrots on the top of the Celery trenches."

— YUCCA ALOIFOLIA VARIEGATA.—Mr. W. Little states there is at present a fine specimen of this highly ornamental plant in flower in the greenhouse at Moncreiffe House, Perth. The plant, which is about twenty years old, is growing in a pot 18 inches in diameter and has attained a height of 10½ feet, girth of stem at the base 1 foot. The main flower-spike, which bears a number of side spikelets, is a little over 2 feet in length, and the flowers are of a pure creamy white colour, resembling somewhat those of *Y. gloriosa*.

— MR. JOHN HEWETT, gardener to H. B. Mackerson, Esq., Hill-side House, Hythe, Kent, sends us flowers of CHRYSANTHEMUM MADAME DESGRANGES AND ITS YELLOW SPORT, exceptionally fine examples of these useful early varieties. The blooms are 5½ inches in diameter, 3 inches deep, of great substance, respectively pure white and clear pale yellow. They are both up to exhibition form, and such blooms would be welcome at the National Chrysanthemum Society's Show next Tuesday.

— WE are informed that the Show held last week of the BURTON-LONSDALE FLORAL AND HORTICULTURAL SOCIETY was a very successful one, and admirably managed by the Rev. F. D. Horner. Plants and flowers were good, while it is stated the fruit and vegetable classes in most cases hardly conveyed the impression of having had to undergo the hardships of an exceptionally trying season; indeed to the keen observer it must be a relief to find such produce can be grown in a season

like the present one with a little extra care. Potatoes were a large class and splendid quality. Beans of all kinds, and Celery, especially in the amateurs, were some perfect exhibits. Vegetable Marrows were numerous and Onions too are worthy of mention as being clean and well grown examples. Collections of vegetables, for which special prizes were offered, receiving high commendation from the Judges. The Judges were Mr. Brooks, Leek Hall; Mr. Geo. Danson, Ingleton; Mr. Burton, Luncfield; Mr. Wilson, Castertou; and Mr. Alvey, Melling.

### GRAPE JUDGING AT THE CRYSTAL PALACE SEPTEMBER 2ND, 1887.—A PROTEST.

As I have been unfortunate enough to have been the only exhibitor of twenty bunches of Grapes, in ten varieties, two bunches of each, at the above Show, I beg to record my most emphatic protest against the treatment which I received at the hands of the Judges who were selected to make the awards in the Grape classes at what may be correctly described as the "National Fruit Show" of this country, in placing me third for better Grapes than those which placed me a "close second" in a good competition the two previous years at the same Show. The twenty bunches in question, I may be allowed to say without being considered egotistical, were greatly admired by Grape growers before and after the award was made. These included, among many others, Mr. Pratt, Longleat; Mr. Goodacre, Elvaston; the Messrs. Goldsmith (one a member of the Fruit Committee of the Royal Horticultural Society of London), Mr. Read (of the Royal Exotic Nursery, Chelsea), Mr. Warden, Clarendon Park; Mr. Pullman, Frampton Court; Mr. Markham, Mereworth Castle, all being loud in their condemnation of the award, not because I was the victim, but because they considered it radically wrong. I may also state by way of giving further strength and justification for making my protest, that a gentleman presiding over a large ducal establishment, and who has frequently distinguished himself as a Grape and fruit grower in the exhibition tents of our large shows, said, in reference to the award complained of, that he had several times seen worse collections of twenty bunches of Grapes placed first in a good competition. Such an expression of opinion coming from such an authority carries conviction with it.

Mine, although the most important, was not the only Grape class in which errors of judgment were made. They were noticeable in the Muscat three-bunch class, basket of white Grapes class, and "any other" black Grape class. In the latter class Lady Downe's were placed first and second, while three neat and well finished bunches of Muscat Hamburg were passed. Therefore, I endorse the opinion freely expressed by Grape exhibitors and growers who were not exhibitors at the Palace on the 2nd inst., that only men of proved competency in judging Grapes, and in whom Grape growers have confidence, should be secured to make the awards at fruit shows of importance. I have no doubt the gentlemen who made the awards in the classes indicated are first-rate men in their respective departments, but I repeat they are not the sort of men that should be selected to award the prizes at a great fruit show; and I may add that if the Judges who made the awards in the Grape classes this year are again invited to act in a similar capacity at the Palace, it is the intention of more than two of the largest exhibitors in the Grape classes withdrawing their patronage. In conclusion, I may say I do not write as a disappointed exhibitor, but simply as one whose exhibits have been placed before the public in an unjust light.—*H. W. WARD, Longford Castle Gardens, Salisbury.*

[We do not know who the Judges were to whom Mr. Ward's strictures apply. Messrs. A. F. Barron, W. Coomber, J. Burnett, J. Woodbridge, J. Willard, B. Wynne, G. Bunyard, W. Earley, S. Ford, J. Laine, J. Douglas, and J. Wright officiated, the three latter in the cut flower section of the Exhibition.]

### THE LILY OF THE VALLEY.

PRaises may be published of recent introductions, but which of them may ever supplant this, or the Moss Rose or Mignonette? Some things therefore in gardening are beyond the caprice of fashion, and nobody doubts the continuance of their influence. For the bridal or any other bouquet who shall despise this lovely chaste flower, whether as a denizen of our forcing houses from December until March, or as yielding its charming groups of little snowy and fragrant bells in our borders and woodland walks in May and June? Some account of its culture from one who has grown it in various forms for the last twenty years may, I trust, prove useful.

The outdoor culture of this Lily is the first consideration; for, like the Seakale, its style and quality when forced depend much on its high culture during the growing season. The Lily of the Valley will grow pretty well in any good garden soil; but to grow it in the highest perfection of which it is capable some extra consideration must be given to the compost. It succeeds to admiration with us in a dark and unctuous loamy soil; and we have a north border here in which I have grown my whole stock for twenty-two years, merely changing from one end to the other in making new plantations. But this border is exceedingly rich in decayed vegetable matter; and

those who wish to excel in Lily of the Valley culture must not fancy that because this plant is found growing tolerably well in neglected situations it is averse to manures and high culture. We have seen them grow in woods in great breadth, and in tolerable style; but then the two chief conditions were present—partial shade and abundance of the decayed leaves of many years.

As to the staple soil, then, for Lilies of the Valley, I am of opinion that a darkish and somewhat stiff soil will produce the finest buds; and one essential is that the ground be not liable to droughts, for they love a permanent moisture. As to shade I have ever found them finest on a north border; but be it understood they are not within 5 feet of the wall, consequently the sun shines freely on their foliage; but then the border surface inclines considerably to the north, and of course the ground is much cooler and damper than it would be on a southern incline. It is very probable that an east or west border would be superior.

There are at least three distinct modes of cultivating Lilies of the Valley for forcing. The first, growing them in patches in the open ground, and potting such patches when two years old. A second is to grow them in pots—the latter plunged in a rich medium; and a third to take up the roots, and single them out in November, sorting all the finest eyes, and placing them thickly in pots adapted to the purpose. I think that for early forcing those grown in pots will be found the best, inasmuch as it is necessary that the roots should not be disturbed, and that the crowns should go to rest betimes. For succession crops they may be cultivated by the first mode; and for the latest the third mode may be best adopted. They will do well by any of the above modes if the roots be strong; if they are badly grown the forcer will be defeated in his aim. I may now detail the planting process, together with the preparation of the soil.

Let a plot of ground be selected in the beginning of March, a plot possessing the conditions before named. It must be deeply dug, and the parts well broken, and during the process means must be taken to introduce as much as 4 inches in depth of very old manure; the kind I prefer is old hotbed linings, composed of about equal parts manure and tree leaves, but which have crumbled to pieces with age and turning. To those who cannot obtain such a valuable article I say lay hold of any old black residue, whether of the wood-pile, the rubbish-heap, old thatch, or old rotten weeds; anything which has once been living vegetables, and has become a black residuum, through age and exposure to the air, is eligible. This, however, I address to the needy; for, after all, there are few things so good as the hotbed linings. The ground being thus prepared stations may be marked out for the Lily patches if to be forced in pots according to our first mode. We force them in pots of about 9 to 11 inches diameter, and it is necessary so to plant the patches that they may readily fit the proper sized pot when taken up.

The ground is marked out in lines of 2 feet distance; these lines to receive the patches of Lilies at about 14 inches apart, therefore pegs put down at that distance form points around which a thick cluster of crowns has to be planted. This done, a pot of about 7 inches in diameter is used to stamp circles around each peg, and on this circle, and within it, they are dibbled as thick as they can be placed. Each patch will thus be made to contain from twelve to fifteen eyes or buds, which are as many as are necessary to form a good potful of blooms; and when planted a top-dressing of rotten manure in a mellow state is spread nearly 3 inches thick all over the surface of the Lilies. Through the ensuing summer they are kept clear of weeds; and after a second summer's growth they are first-rate buds, and will give every satisfaction to the forcer.

I may now advert to the second mode—growing them in pots. I will not say what has been done, or what may be the general practice, but rather point to what I conceive would be a superior practice. They need a pot wide and shallow, rather than narrow and deep; and I think we may say pots about 10 inches in diameter, and about 7 to 8 in depth, would be highly eligible. But as I have to recommend a plunging mode of culture in order that the roots may avail themselves of a richly prepared soil outside their pots, the pots should have plenty of holes all over their bottoms, and even round the side, about 2 inches above the bottoms of the pots.

The crowns or buds should be planted as thickly as they can be set in the beginning of March, and the compost must be of the most generous description. About half of an unctuous loam, and the other half old dung and leaves, almost become a mould, with a little silver sand, will grow them well in pots, putting some coarser manurial matters over the drainage; and if crocks are used they should be very coarse, in order that the fibres may get through with facility. These things done, I have to recommend a prepared bed to plunge them in. Nothing would be better than a bed of half-decayed leaves, or anything of similar texture, even manurial matters. This should be quite above the ground level, in order to avoid swamping. As before observed, a situation where they would get only half a day's sun would be well, only there must be no trees overhead. They would



require regular waterings through the season, and when in active growth liquid manure.

Now, it will require a second season's growth to produce strong blooms, although with every appliance they may be bloomed the first season, providing the roots were very strong. A second season's culture, however, will amply repay the exercise of patience. In November of the first year they had better all be moved, and those roots which are through the pots trimmed away, for if suffered to proceed unprotected I fear the check would be too great in the second autumn. Being turned round, therefore, or replunged they will be ready for another summer's culture; and about the second week in October, or as soon as the foliage begins to assume an autumnal tint, those which are required for very early forcing may be unplunged, the side fibres outside the pots cut off, and the pots placed in a very sunny corner, to hurry their buds to a state of rest. Before the sharp frosts set in they may have their decayed foliage cut away, and be plunged overhead.

About the third practice little need be said. The soil will of course be prepared as advised in the first detailed practice, and in planting the roots may be either dibbled thickly in rows or planted all over the bed. In all other respects they may be treated as the others, and at the end of the second summer they will be fit for forcing. The buds intended for selecting from must be taken up in the beginning of November, and the roots sorted carefully—all the largest crowns being reserved for potting. These may be singled out and dibbled into any size of pot or box desired, and protected as recommended for the others.

Thus much for culture outdoors. Now a few words about the forcing. There is no difficulty in this procedure if plenty of time be given; for they would, doubtless, blossom much before the usual period, if only placed beneath the greenhouse stage; but to obtain good blooms in December and January is altogether another affair. To accomplish this, it is necessary to resort to bottom heat, and I have found from 70° to 75° most congenial. My practice is to plunge them overhead in warm tan or leaves; but care must be taken to uncover them as soon as they have sprouted about 2 inches in length, or they will become so weak as not to be able to sustain their weight. It is necessary to place a lighter or finer material over their crowns when plunged, or the pressure of the leaves or tan will bind them down and spoil their character. I always pile up a mound of finely riddled old tan over them, and this answers admirably. We sometimes force them in the Mushroom house, sometimes in front of a Pine pit; and, indeed, the structure is quite immaterial, as darkness is essential until they have sprouted a couple of inches. Care must be taken on their first introduction to light that it be done gradually, and it is best to place them in a shady part of the greenhouse or other structure for awhile, protected equally from cold currents of air and from sunshine, and they should be frequently syringed; in fact, a rather moist atmosphere is indispensable, and a temperature from 50° to 60° will be amply sufficient until in blossom, when the cooler they are kept the finer will the blooms be, the longer they will endure, and the higher will be their scent.

When the foliage becomes green by exposure to light and air they will be improved by sunshine at an early period; but as the spring advances little sunshine will be necessary. They will require water liberally whilst in blossom. The freer the circulation of air the higher will the scent be; and I should prefer, at the blooming period, a temperature of from 40° to 55° to a higher one, and they will thus continue much longer in blossom.—R. E. N.

### A STUDY IN MY GARDEN.

[By H. W. S. Worsley-Penison, F.L.S., &c.]

It is July, and the season of 1887 being, after the almost unparalleled winter preceding it, remarkably late, my Roses are in full bloom now, instead of in June, as is usually the case. The severe and long continued cold weather has played sad havoc with most of our garden treasures. All the flowers have been more or less short-lived. Pinks, Larkspurs, Columbines, Speedwells, Saxifrages, Lilacs, Laburnums have all passed away before we had more than time to know that they had come. Their advent, long delayed, was succeeded by many days of suddenly coming hot weather without one single shower of rain. The consequence has been that the plants lacked stamina, as we call it; their blossoming has proved too exhausting a process for their powers, and has soon come to an end. So far, the only flowers that appear not to have suffered are the good old-fashioned Snapdragons and Sweet Williams. These seem to be quite independent of all the unfortunate influences affecting the rest.

Among the sufferers I find my Roses, as I fully expected would be the case. They are late in appearing, and they lack the full, healthy, glorious beauty that is a source of so much joy to anyone who cares for his garden. The dull appearance of the leaves speaks of damage done by frostbite during the bitter cold of May. The result is that the circulation of the life-giving sap is impeded, and an unhealthy condition of the plant-tissues comes about.

This would be disastrous in itself, but there is a further and much more deadly mischief to follow. Just as unhealthy soil generates diseases in virtue of its being exactly the kind of soil in which disease-germs can best be propagated, so a Rose tree whose tissues are rendered abnormal by bad circulation, forms a sort of living soil in which "germs" can grow and flourish. So surely as this condition of affairs exists, so surely will the germs be found. With what result? This—that the fresh young shoots of the Rose will very soon be entirely covered with what is known as the "green blight," or plant-lice, or by the more learned name of aphides.

These will be present in such large numbers that in even looking at the tree it is impossible to avoid seeing that the shoot is loaded with them. I wish, in this paper, to go beyond this point, and to watch and observe them; to find out from what germs they originally came; to ascertain their method of life and the work they do; to see how they fare in the struggle for existence; who their friends may be, and who their foes.

Such a life-history as that which the aphid presents to our view will furnish an admirable example of the fund of interest and instruction that always rewards the steady culture of the observing faculty.

It is, perhaps, most convenient to begin this study at the "egg" period, although, for some reasons, it might seem better to start from the time when the insect itself can be easily seen and examined.

If a Rose tree be carefully inspected during the winter, there will be seen on the twigs a number of tiny grains, very much like those of gunpowder, giving the appearance of such a powder, or that of black pepper, having been scattered or dusted all over the twig. These are the minute eggs of the aphid. They were laid by the winged females in the preceding autumn, and when first deposited were of a greenish yellow tint, which has slowly changed to the black hue just described. They are securely fastened to the plant by a gummy fluid secreted by the insect as she passes them from her ovipositor on to the twig.

In the case of the Rose aphid, the eggs are comparatively large, being over one-third the length of the parent, and are placed singly, only three or four being inside the body in the fully developed state at one time. Directly one egg is laid the germ of another is ready to be perfected, so that one aphid may deposit a large number during her lifetime. Some species of aphid place the eggs in groups of four, five, or six, while there are others which deposit the eggs in clusters of some hundreds. Of these very fertile aphides that found on the Larch is an example, where each separate egg has, moreover, a tiny stem of cement attaching it to the plant-surface.

As a rule, as soon as the eggs have been laid the female dies, the laying process being sufficient to exhaust all vital power.

If for any reason, such as a low temperature, this process should be delayed, the parent lives for a much longer period, in obedience to a well-known law of insect life by which the death of such a creature is postponed until it shall have fulfilled its great life-task—that of providing a family who shall inherit its "goods, chattels, and effects."

It is stated that the Larch aphid, before named, forms an exception to the general rule that the winter time is passed in the egg state. In these aphides the last brood of the autumn season do not deposit eggs, but pass the winter in hibernation, and awake in spring to take up their duties once more. I have not myself verified this statement; therefore I take it on trust, but there are good authorities for it.

The exception proves the rule, however, which is that only in the egg condition can the frost of winter and the absence of proper food be sustained.

The winter having passed away, the eggs, safely hidden away as far as is possible from harm, are quickened into life by the warmth of spring, or early summer, and the first brood of "green blight" appears. These are of course, infantile aphides.

Now, it is perfectly well known that nearly all insects pass through certain metamorphoses—some incomplete, some complete—as they are respectively termed. In these metamorphoses we find four different conditions, as follows:—1, The egg. 2, The larva, caterpillar, or grub. 3, The pupa, chrysalis, or nymph. 4, The imago, or perfect insect.

The hymenoptera, including bees, ants, &c., are examples of complete metamorphosis, where larva and pupa differ entirely from the perfect insect, and where for the most part the pupa is quiescent. (The gnat, belonging to the diptera, has an active pupa, which, however, takes no food.)

The neuroptera, including dragon flies, May flies, &c., are examples of incomplete metamorphosis, where larva and pupa are more or less like the insect, and are active.

The dragon fly changes its coats, but not its body to any great extent.

The bee changes its body form inside the coats.

How about the aphides? Where do they come in this classification? They belong to a group termed homoptera, or "like-winged," so called because the wings, when present, are all alike in texture—i.e., the front pair and the hind pair are entirely membranous and transparent. They undergo incomplete metamorphosis, being very much of the same outward appearance in all three stages.

Now, some naturalists distinguish between larva, pupa, and imago among the aphides, and so far as the direct result of the egg-form goes, they may be right; but we shall presently see that at a later period, genuine living aphides are produced, which form a notable exception to the almost universal rule of metamorphosis, since they pass through nothing of the kind. In this, they resemble certain insects of a low type, such as the parasitic lice, the skip-tails, and a few others.

How, then, does the larva form of aphid differ from the fully developed insect as seen on the Rose shoots?

Chiefly in that the antennæ are a little shorter and possess fewer joints, the legs smaller and stouter, and the so-called "nectaries" only very slightly developed. Such is the larva form, and I purposely say no more about it, until I come to speak of the insect in its fullest development.

The pupa form is seen only in some cases, those, that is, in which wings are developed, the rudiments of such organs being seen as minute swellings on the thorax.

Allowing, then, for these changes in the size of the antennæ and other organs, let us look at the aphid as ordinarily seen on our Rose trees.

Pick off one of these little creatures—whose numbers we endeavour to diminish by aloe, quassia, tobacco juice, and other mixtures—and put it under a microscope of low power. You will see a roundish, or oval, transparent green body, supported by six legs, which are jointed and hairy; there are two large black eyes, with several facets, and two antennæ, long and very flexible, lying (if not in use) along the back and reaching nearly to the far end of the body; the creature may have wings, or not, as the case may be. Besides these details, you will see a proboscis, or rostrum, as it is called, very probably folded up underneath the body; it is easily pulled out from this position of rest, and will be found to be of an appreciable length. This is used as a sucker by which aphid can extract the juices from the plant tissues.

Notice lastly, about two-thirds of the way down the back, a pair of tiny, bristle-like organs, pointing backwards. These are the nectaries, or cornicles, hollow tubes by means of which the insect emits the sweet fluid known as "honeydew."

Such is an outline of the external appearance of the aphid.

The rostrum consists of a three-jointed sheath, inside which are three sharp-pointed lancets, capable of backward and forward motion, in order to puncture the leaf surface. In those which live on leaves this rostrum is short, because the sap being near the surface great length is not necessary, but in some aphides that are found on tree bark the rostrum is much longer, enabling the insect to penetrate to the required depth, in order to get at the sap. In the Larch aphid the rostrum is not only long, but also spirally coiled; thus it can form, when introduced into the bark, an anchor by which the aphid can hold fast in a gale of wind.

The secretion from the cornicles is, of course, the result of the supply of juice from the plant, and is given off in drops as these gradually accumulate at the tips of the tubes. These drops fall on the grass, or on the leaves, as the case may be, and if it be deposited to any great extent on the leaves a still further damage is done to the plant, for not only has aphid deprived it of sap, but this thick treacle-like honeydew falling on the leaves chokes the leaf-pores, or stomata, and prevents the proper respiration normally carried on by these pores. The name "honeydew" has been given to this secretion for its sweetish taste and its appearance when it has fallen on the grass or leaves. It is not by any means always allowed to fall and waste itself, as will presently be seen.

So much for the description of a typical Rose aphid and the life it leads. Its colour I have said is green. In other species we find the colour varies. Grey, dark olive, black, white, yellow, red, and violet are all known. The black species is familiar to everyone, as seen on the common Bean plant. The yellow, red, green, and grey are found on the Apple.

The life led by the aphides is perhaps the most purely inactive and vegetative among insect lives. It consists in residing almost continuously on the plant, sucking its juices, assimilating them, giving the honey-dew off by the cornicles, growing a little, reproducing themselves with enormous rapidity, and then there is an end of them. Grant Allen calls their life "duller than that of the very dullest cathedral city," and yet I suppose they enjoy it after their fashion.

We have seen that the first brood of young aphides are the direct product of the eggs laid during the preceding autumn, and that these pass through a kind of larva stage (and in some cases through a pupa stage as well). They moult their skins four times, and all these "moult" may be compared to the intermediate stages of a dragon fly. Having done this, they are now mature aphides.

They are very peculiar creatures, in that they are all wingless, and are all females. These give rise, asexually, to a second brood, exactly resembling the first—*i.e.*, imperfect females. This process is repeated ten times (some say eleven) during one summer, and in each case without any male intervention at all. The new group is produced by a kind of "budding" process from the preceding one, the "buds" being, like those of a plant shoot, simply facsimiles of those whence they come. They pass through no metamorphoses whatever, but are born in the likeness of their parents (or rather parent)—*i.e.*, they are all imperfect females—imperfect, because wingless. A few winged forms may be very often seen side by side with the wingless ones, but of this there seems to be no satisfactory explanation.

This freedom from the usual law of metamorphosis accounts of course for the astonishing rate at which we see their numbers increase during a single summer.

The last brood—be it the tenth or eleventh—differs from all those preceding it in that it consists of both males and females, all of which are winged. The latter, after being fertilised in the usual manner, lay their eggs in autumn, and so complete the wonderful cycle of the year's generations of aphides.

It will be seen that out of eleven broods ten are made up of imperfect females, while the remaining one consists of perfect insects, both male and female.

As to the actual rate of multiplication, Réaumur calculated that one female produces, in round numbers, about ninety young ones. She lives to see children's children to the fifth generation—*i.e.*, to the number of ninety multiplied by ninety four times over, or 5,904,900,000. This, of course, presupposes that all the five generations go on unchecked by any accident, or undiminished by doses of tobacco, or other insect-destroying fluid. Carrying the calculation further, it is found that one aphid would in a single season produce a quintillion of aphides.

I leave my readers to write this out in figures for themselves. They will find it needs thirty-one figures to express it. A mathematician has computed the number of the progeny of one aphid if allowed to go on unchecked for 300 days, and he finds they would entirely choke up the universe, land and water, so that no living creature, save themselves, could possibly exist.

Professor Huxley, assuming that 1000 aphides weigh one grain avoirdupois, and that a "very stout man" weighs 20 stone, or 280 lbs., says that the tenth brood alone of one aphid would be equal in actual matter to more than 500,000,000 of such men, or nearly one-third the population of the entire world. Imagine this calculation carried to the 300th day—*i.e.*, to the fifteenth generation, and the sum total is almost beyond realisation.

How is it, then, that we poor human beings can exist at all in a world where the aphid co-exists? Because the beneficent law of compensation steps in in the shape of many enemies to aphid life. The account of these various foes which keep down the numbers of our so-called Rose pest, their interesting life histories, and the fascinating study of the relation of aphides to their friends—the ants—who care so tenderly for them, I must leave for a second paper.—(*The Naturalists' Monthly.*)

#### LAMBTON CASTLE.

PASSING Durham by rail for the north a glimpse is obtained of that picturesque city, its grand old cathedral, and the delightful valley of the Wear, and the view, though hurried, is sufficient to induce many a traveller to break his journey for an hour or two to visit the local antiquities and enjoy the riverside scenery. The Wear is distinguished by its steep high banks densely covered with trees and undergrowth down to the water's edge, by its circuitous course and the beauty of the surroundings for at least a large portion of its length, until it reaches the neighbourhood of busy Sunderland. From Durham northwards for several miles it is exquisitely beautiful until Lumley and Lambton Castles are reached, the latter (fig. 27) rising from a luxuriant forest-like growth at the top of its steepest and most lofty bank, having a very fine appearance. To reach Lambton Castle most conveniently by rail, however, Chester-le-Street or Fence Houses may be chosen. If the former is selected it will give an opportunity of visiting some other places of interest to the horticulturist before proceeding to the great garden. Perhaps the best way to see the natural aspect of the place is to journey by road from any of the large towns within driving distance, and Lambton is easily reached in this way from Newcastle, Durham, or South Shields. Approaching by road from the last-named town the park is entered at the lower lodge, the road gradually ascending until it crosses the Wear some distance below the Castle, and commanding a fine prospect of the richly clothed valley and the winding river. This is a delightful position for the view, which is scarcely surpassed by that obtained from the terrace of the Castle itself. It is one of those fresh and verdant denes or dells so frequent in the north, and which come as such agreeable surprises to railway travellers. The surrounding ground is often comparatively bare, or at least but sparsely clothed with trees, and all the vegetation is concentrated in the valleys. The protection afforded by the banks and the moisture no doubt account for this, and it is easy to take advantage of these circumstances, and improve the natural condition of the place by planting where the keen easterly and northerly winds of winter and spring cannot do much damage.

A short distance over the bridge and then to the right, and the garden so ably managed by Mr. J. Hunter are reached, where from beautiful scenery we pass to some of the results of horticultural art, and where Mr. Hunter has achieved so many triumphs in Grape culture. The garden comprises about thirteen acres, the greater part sloping to the south, with two ranges of glass houses at the upper part connected by a conservatory in the centre and another long range against the wall in the kitchen garden, and which was formerly devoted to trained fruit trees. On the right hand side of the engraving (fig. 28), which gives a general idea of the position of the garden, finely backed up with trees on the north, is the gardener's house, a handsome commodious villa-like structure, such as is seldom seen in gardens. From that extends the principal range of glass houses, with a fine terrace and flower garden in front 324 feet long. Borders the whole length of this are filled with Pelargonium Robert Fish, blue Lobelias, and angles of Mesembryanthemum cordifolium, on a general ground of Antennaria tomentosa. A few Pelargoniums, large Agaves, and Iresine Lindenii are employed to vary the appearance with good effect. Another border here is occupied chiefly with Veronica repens as the ground, with Echeverias and Pyrethrum Golden Feather, the latter well coloured. A light fence as a boundary to the terrace, covered with Clematis Jackmanni, and loaded with rich purple flowers, is a charming feature. On the slope shown at the left-hand side of fig. 28, outside the kitchen garden wall is a series of scroll beds on white sand, edged with Box, and having a number of



pretty little *Retinosporas* as central plants, surrounded by *Lobelias* and *Alternantheras*. This has a very distinct appearance, especially when viewed from the upper part of the garden, the white sand in contrast with the dark green Box bringing it out in bold relief. Numerous beds of herbaceous plants are attractive, ornamental shrubs, trees, and Conifers being scattered about freely in suitable positions.

But we must turn our attention to the houses, as in a hurried visit there is not much time for all the departments, and the fruit is one of the specialities at Lambton. The range on the lower wall, termed the Orchard range, is in several divisions, and yields a quantity of useful produce from fruit trees in pots or planted out. With very little artificial heat the trees bring their fruits of much larger size, ripen better, and the crops are more regular than outside. The roots are well under control, both as regards the supply of water and stimulants also for restriction if necessary, and in the northern counties of England houses of this kind are invaluable. Some of the produce of trees in this house was included in the premier collection of fifty dishes at Newcastle, and afforded a good example of what can be done with such assistance in an unfavourable season or situation. The first division is partly occupied with Plums, yellow and white *Magnum Bonum*, *Prince Englebert*, and *Pond's Seedling* being the chief varieties. In the front of the house raised to the roof are cordon Pears of the leading varieties, and bear-

dition, and are liberally treated, Thomson's manure being found a useful stimulant as a top-dressing or mixed in the borders. Some of the older Vines have, however, been removed, and one house has been entirely replanted, the young Vines making good progress and promising well for future seasons. In one of the houses an interesting experiment has been tried with *Gros Colman* worked on Foster's Seedling side by side with one of the same variety on its own roots. A remarkable difference is seen in the colouring of the Grapes, those on the worked *Gros Colman* having coloured well, while the others are at present nearly green. The newly planted vinery is utilised for young Apple trees and Tomatoes, *Hackwood Park*, *Large Red* and *Criterion* being the principal of the latter, and the first-named the chief favourite. The conservatory is a peculiarly shaped building inside, but it is very picturesque and filled with a number of ornamental plants, including some fine specimen Palms, *Phoenix dactylifera* being of great size and in fine health. A large plant of *Cycas revoluta* has a crown of its peculiar orange-coloured fruits, a dish of which was included in the large collection at Newcastle. Ferns are numerous. The little *Ficus repens* covers a good portion of the wall, and some arches are clothed with *Epiphyllums*, which must have a beautiful effect when in flower. A flight of steps conducts to another portion of the conservatory at a higher level, and besides a number of miscellaneous plants we find *Eucharises* planted out

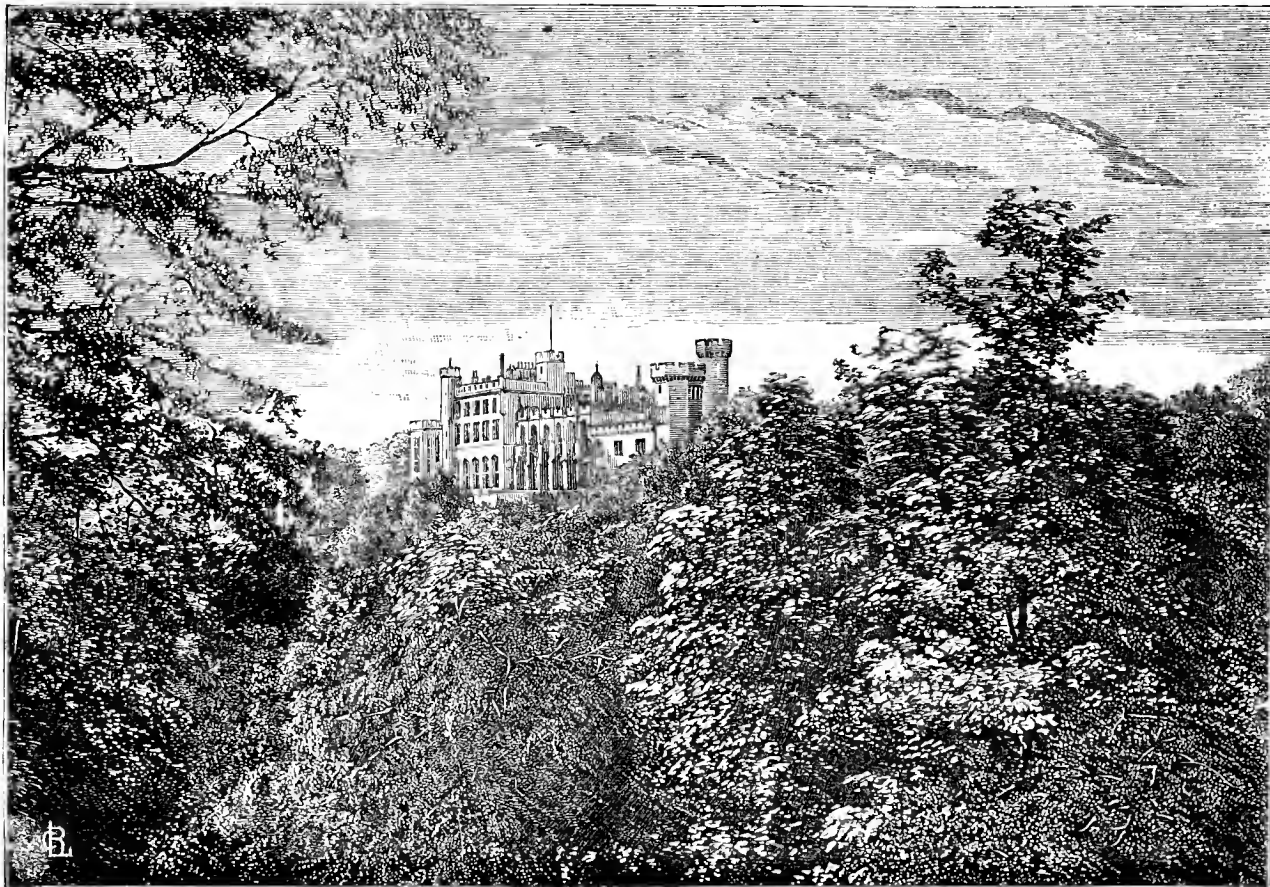

Fig 27.—LAMBTON CASTLE, S.W. VIEW.

ing fine fruits, all spare space being filled with Tomatoes. The Pear have been planted out four or five years, and have proved quite satisfactory. In an adjoining division the back wall is covered with Peaches and Nectarines, Pears occupy the front of the house, Tomatoes and Chrysanthemums for early flowering being used as temporary crops for filling up. Some of the favourite Peaches in this house are *Alexander*, *Goshawk*, and *Rivers' Victoria*; the best Nectarines being *Lord Napier* and *Pine Apple*. Of Pears, *Durondeau*, *Beurré d'Amanlis*, *Doyenné du Comice*, *Pitmaston Duchess*, and *Beurré Diel* have handsome fruits, clean and well developed. These are only a few of the best, but the collection of Pears is a large one, as over fifty varieties are represented indoors and out, and 100 varieties of Apples.

The upper range overlooking the terrae flower borders contains the principal vineries, which have produced such magnificent Grapes, and in which may be seen some good bunches now. Mr. Hunter has abundantly proved his skill as a Grape grower, and has shown bunches of sensational size on several occasions, but the character of the demand has altered; the extensive supplies now raised at Lambton consist more of medium sized bunches, with good berries and well finished. A moderate sized compact bunch of Grapes, in which the berries are large and the colour good, is usually more satisfactory on the table, is very strong at an exhibition, and possesses a substantial commercial value. There are, however, some large bunches to be seen yet, and a sixteen-year-old Vine of *Alicante* is bearing some grand specimens, as also is *Trebbiano* in another house. The Vines are in healthy fruitful con-

son the shelves thriving well and yielding abundant supplies of flowers, while Pear trees in pots occupy all the space that can be spared near the glass. This system of utilising every portion of the houses prevails throughout the establishment, and the quantity of produce, both in flowers and fruits, is very great in consequence. A vinery on the other side of the central house contains vigorous Vines of *Trebbiano*, *Golden Queen*, *Calabrian Raisin*, and *Gros Colman*, while in the earlier houses *Black Hamburgh* is the variety relied upon, the greater part of the crops having been cut previous to our visit. One variety is grown that is not often seen—namely, *Burchardt's Prinee*, or *Aramon*, which is distinguished by its long bunches, one Vine having eleven good specimens. It is a late variety, and is sometimes of good flavour, but not reliable in this respect. It is said in Dr. Hogg's "Fruit Manual" that the Grape is "extensively cultivated in Languedoc and Provence on account of its great fertility and the large quantity of wine it yields; but the wine is not of a high character; being principally the *vin ordinaire* of that part of the country." The early Peach house had been stripped of its fruits, but there also we find *Camellias* and Pears in pots all looking healthy and satisfactory.

A number of outside pits and frames are also devoted to plants and fruits, *Ixoras*, *Gardenias*, Apples and Melons being all extensively grown in this way. *Crotons* are a speciality for decorative purposes, one house being filled with plants of various sizes, and splendidly coloured, such varieties as *Queen Victoria*, *Weismanni*, *Mrs. Dorman*, *angustifolius*, *Warreni*, *Chelsoni*, and *Andreanus* standing out prominently for their



effective appearance. Imantophyllums are prized, and some strong plants are grown, a marvellous plant of *Allamanda Hendersoni* on the roof yielding thousands of its rich yellow flowers every year. The kitchen garden is well cropped with vegetables, and contains besides a number of healthy fruit trees, but the outdoor fruit crops have felt the effect of the late spring and dry summer. Small fruits have, however, been very abundant. There are several beautiful shrubbery walks leading to the Castle, and from the terrace surrounding this imposing structure lovely views are obtained across the Wear valley and its rich arboreal vegetation.

A day would be required to be spent at Lambton to see all that is interesting and do justice to the garden, but an hour or two suffices to show that Mr. Hunter's fame as a practical gardener is amply merited, for the whole garden and its contents is distinguished by a uniform good quality that is surprising considering the diminished staff of assistants with which he has to work.—LEWIS CASTLE.

#### DESCRIPTIONS OF AURICULAS—SELFS.

(Continued from page 143.)

*Berry's Lord Lec.*—A fine round self with a good truss of flat pips of a bright deep rose colour; but with no paste, or with what is called a

*Holland's best self Seedling.*—Sent to me two years ago for my opinion. Though all but pasteless it is well worth growing, and therefore worth a name, though on account of its blanket centre it would disqualify a pan. Pip round, indented instead of angular, of good size, flat; colour plum black extremely soft and velvety; paste a few scattered dots of meal on a yellow ground; eye lemon with low anthers, in good proportion. Foliage healthy, veined, serrated.

*Lightbody's Admiral of the Blues.*—A poor thing except for trussing; pip anything but flat, tolerably round; colour a violet plum; paste narrow, thin, angular; eye lemon, irregular in shape, anthers above surface. Foliage large, broad, thickly mealed, slightly serrated.

*Lightbody's Meteor Flag.*—Two distinct flowers according as it is viewed at first opening or after it has opened a week, and, contrary to what is usual, the latter is the best. At first it is a flimsy uneven flower of a thin clarety blue colour, and will disappoint. Afterwards it becomes a large, circular, flat one of a clear violet blue, of no great substance, but which lasts long in beauty. Paste circular, of insufficient breadth; eye lemon and bleaches, anthers not above the surface. Foliage very large and long, abundant, jagged, fully mealed.

*Maltby's Oxonian.*—Cannot be discarded till a better appears of equal shape and similar colour. The latter indeed is found in Smith's Mrs. Smith, but this does not supply all that is wanted. Pip flat, a perfect

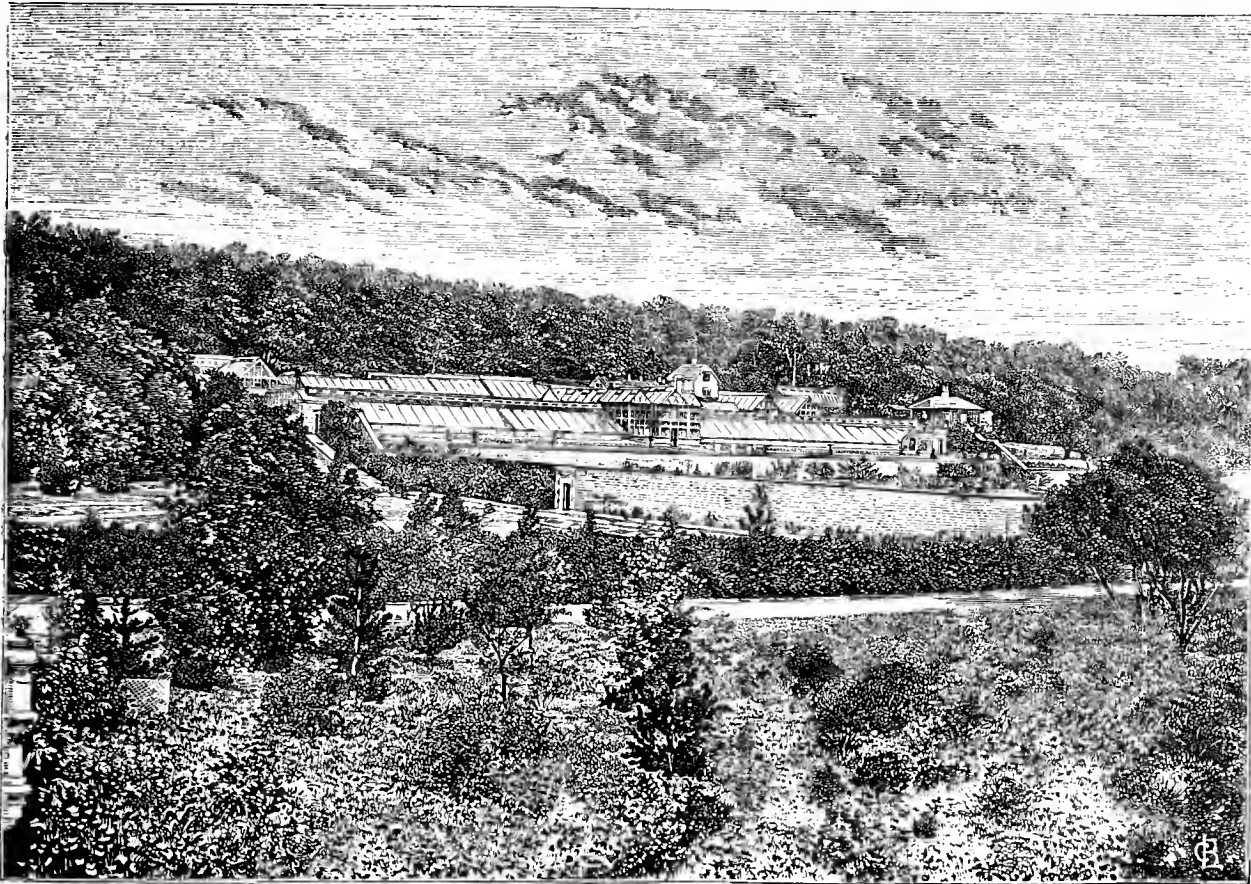

Fig. 28.—LAMBTON CASTLE FORCING HOUSES AND KITCHEN GARDEN.

blanket centre, like *Flora's Flag*. Eye small, round, lemon; foliage light green, glossy, without meal.

*Clegg's Blue Bonnet.*—A flower of no substance, but which like *Meteor Flag* remains long in bloom. The colour is that rosy plum that in the *Dahlia* is miscalled purple; it is an immense trusser, not unshapely; the pip large, round, sufficiently flat; paste circular, and brilliantly white; eye circular, lemon. Foliage light coloured and flimsy.

*Faulkner's Hannibal.*—Both in Scotland and in Manchester this is said to be an alias for *Hutton's Squire Mundy*. I have never grown the latter, without which I am not competent to decide the question; but the pip that was sent me from Scotland for comparison bore no resemblance except in colour to that of *Hannibal*. It is of the less consequence, as upon four years' trial side by side I am satisfied the variety is not equal to either *Blackbird* or *Bessie Bell*. It is a bold and striking flower throwing immense trusses. This year, 1860, I had two on an extra sized plant carrying twenty-two and twenty-four respectively. The former alone was allowed to stand and to open all its pips, but they were too many for it. Pip round and sufficiently flat, colour maroon, paste narrow and angular, eye orange, with anthers above the surface but not so prominent as those of *Blackbird*. Foliage light green, pear-shaped, abundant, much veined, and mealed up the rib, very distinct.

*Gorton's Stadholder.*—A mere yellow *Primula*; but as it is as yet the best of them it may for the present retain a place in the box; foliage evenly mealed and handsome.

circle except where the inverted points leave an indentation; colour deep clarety violet; paste thin, narrow, undefined, showing the colour through; eye pale greenish yellow, anthers high. Foliage narrow, short, smooth, compact, low spreading, light green, slightly indented.

*Martin's Eclipse.*—Pip tolerably flat and circular, of good substance, hardly large enough; colour dark brownish plum; paste circular, insufficient, good as far as it goes; eye lemon, anthers at the surface. Foliage very smooth, evenly mealed.

*Martin's Miss Black.*—Too small. Like *Eclipse*. Pip of medium flatness, under size; colour reddish maroon; paste starchy, and insufficient. Foliage mealed.

*Martin's Mrs. Sturrock.*—The best self up to this time (1860) when it trusses well, which is not always. Pip perfectly flat and round, truss good; colour a striking full crimson; paste good and circular, almost broad enough, as broad as in any self; eye pale yellow. Foliage very erect, narrow, mealed, may be mistaken for that of *Mary Gray*.

*Parker's Metropolitan.*—Pip small, round; colour beautiful violet plum, lighter than *Oxonian*; paste narrow; eye orange, anthers above the surface. Foliage small, serrated, mealed up the rib.

*Sim's Elza.*—A refined flower of a deep shade of maroon; pip flat with broad petals; paste very round and good, but not broad enough eye lemon. Foliage mealed but not thickly so, handsome.

*Sim's Vulcan.*—A fine dark flower, often the best of them; as dark as any of the maroons, perhaps darker; not flat, circular; paste angular and insufficient; eye full, orange; foliage curled and mealed.

*Smith's Mrs. Smith.*—Fine medium-sized flower. Pip circular, flat; colour blue black, often darker than Oxonian; indeed, it is not in character when otherwise; paste far better than Oxonian's but insufficient in breadth; eye lemon with low anthers. Of a curious compact habit of growth and late flowering in consequence. Foliage narrow, thickly veined, dry looking.

*Spalding's Blackbird.*—A fine thing, bold and good, and an excellent trusser. Pip not flat but wavy, large; colour dark maroon; paste round, but insufficient; eye orange, anthers too projecting. Foliage long, narrow, abundant, light green, smooth.

*Spalding's Bessie Bell.*—A good thing, very like Blackbird, but distinguishable from it by the eye, which is of lighter yellow. The colour is the same dark shade of maroon, and the pip is of the same shape, somewhat smaller, and flattens better. The foliage differs, being broader, shorter, and not so abundant.

(Concluded.)

### MEETING OF THE FLORAL COMMITTEE AT CHISWICK.—SEPTEMBER 1ST, 1887.

PRESENT:—George F. Wilson in the chair; Major Lendy, John Dominy, W. Holmes, John Fraser, W. Goldring, H. Herbst, R. Dean, James Hudson, A. Perry, S. Hibberd.

The collection of Asters grown in the gardens was examined. These had been received from Messrs. Carter & Co.; Benary, Erfurt; Vilmorin, Paris; and T. Laxton, Bedford. Although the season being so hot and dry has not been very favourable for Asters, those planted in the Gardens have done extremely well, the flowers being large and good, although somewhat battered by the late rough and boisterous weather.

Messrs. Carter & Co. sent twenty-five varieties, the following being considered worthy of marks:—

<i>Chrysanthemum Flowered Asters.</i> —Height 12 inches.		
Copper coloured	* * *	English seed.
Crimson	* * *	"
White	* * *	"
Light blue	* * *	"
Dwarf French rose	* * *	Continental seed.
" " light blue	* * *	"
" " blue and white	* * *	"
" " carmine	* * *	"

<i>Paeony Flowered Asters.</i> —Height 2 feet, flowers incurved.		
Rose	* * *	English seed.
Dark blood red	* * *	Continental seed.
Rose with white	* * *	"

<i>Pyramidal.</i> —Light blue		
"	* * *	English seed.
"	Purplish crimson	* * *
"	Fiery scarlet	* * *

Messrs. Benary, Erfurt, sent nineteen varieties, the following being awarded marks:—

<i>Victoria Asters.</i> —Height 12 to 18 inches, Chrysanthemum flowered, very large and double.		
Rose and white	* * *	
Dark blue and white	* * *	
Crimson	* * *	

*Mignon.*—Height 12 to 18 inches, resembling in habit and form of flowers the Victoria, but somewhat smaller.

" Pure white \* \* \*

Messrs. Vilmorin, Andrieux & Co., Paris, sent twenty-four varieties, the following being considered worthy of the following marks:—

<i>Crown Asters.</i> —Height 12 to 18 inches, small Chrysanthemum flowered, the centre or crown white.		
"	Mixed.	
"	Half dwarf multiflore mixed.	
"	" light yellow.	

*Chrysanthemum* flowered, those flowered, height 12 inches, flowers large, double, fine. \* \*

Imbricated mixed (Victoria) height 12 to 18 inches, large, Chrysanthemum, fl.		
" Pompon mixed.		

*Pyramidal Bouquet rose.*—Height 2 feet, compact, very floriferous, Pompon flowered, rosy lilac, very pretty. \* \* \*

*Pyramidals dwarf mixed.*—Height 12 to 18 inches, compact, very floriferous, Pompon flowered, pretty. \* \* \*

*Harlequin.*—Pompon flowered, some of the petals streaked with white.

*Pyramidal Purple.*—Purple and white \* \* \* height 18 inches.

" Red.—Red and white \* \* \* " 18 inches.

Half dwarf.—Red and white \* \* \* " 6 inches.

*Lilliput* (China) mixed, small Pompon flowered, partly quilled, colours very bright, and exceedingly pretty. \* \* \*

### HORTICULTURAL SHOWS.

CRYSTAL PALACE.—SEPTEMBER 2ND AND 3RD.

It is questionable if two such shows have been held together, equalling in magnitude and merit the great Fruit Show, for which provision was made by the directors of the Crystal Palace, and the National Dahlia Show. The produce was effectively arranged, and appeared practically to occupy the whole of the area in the splendid transept of the large building, and was admired by a large number of appreciative visitors. Dahlias were staged in greater numbers than we have previously seen, and many of the blooms were characterised by much of the refinement that prevailed in the old Dahlia days of thirty years ago, and for which mere size, with its almost inevitable coarseness, can never compensate, while the fruit generally was admirably represented; indeed a better aggregate display has never been staged in "The Palace," and the directors, with their garden superintendent, Mr. W. G. Head, are to be congratulated accordingly.

### THE FRUIT SHOW.

Some new exhibitors entered the competitive lists and acquitted themselves well, while others, whose names are familiar, by no means went empty away, yet some "old Palace winners" were not in the fray. All the table space appeared to be occupied, and there was a marked absence of inferior produce that is not infrequently too prominent at the leading shows.

**COLLECTIONS.**—These of themselves constituted an exhibition of no insignificant kind. In the three classes of twenty, twelve, and eight dishes, upwards of £60 were offered in prizes. In the first mentioned class four varieties of Grapes were allowed, two bunches of black and two of white; two Pines, two Melons, and two dishes each of Peaches, Nectarines, and Plums, the remainder distinct. Mr. H. W. Ward, gardener to the Earl of Radnor, Longford Castle, Salisbury, secured the premier position with splendid fruit excellently arranged. The dishes comprised grand solid bunches of Muscat of Alexandria, Alnwick Seedling, Foster's Seedling, and Gros Maroc Grapes, this latter having wonderfully fine berries; good Pines; very large and handsome Melons; superior Figs, Peaches, and Nectarines, and good Oranges, Apricots, Plums, and Currants; this was a collection of commanding excellence and worthy of the £12 prize. Mr. J. H. Goodacre, gardener to the Earl of Harrington, Elvaston Castle, was the second prizewinner, with heavy bunches of Madresfield Court, Black Hamburg, Muscat of Alexandria, and Foster's Seedling Grapes, large Pines, fine Peaches, Nectarines, Cherries and Plums, and a dish of Triomphe de Saisons Strawberry. Mr. W. Pratt, gardener to the Marquis of Bath, Longleat, Warminster, was third, his Grapes large, but some of the other dishes comparatively light, yet far from being inferior. Another good collection was staged. In the class of twelve dishes Mr. Pratt secured the foremost place with splendid Muscat and Black Hamburg Grapes, good Pines, Melons, Peaches, Nectarines, Figs, Plums, Apricots, and Apples; Mr. Goodacre was an excellent second; and Mr. W. F. Smith, Neville Court Gardens, Tunbridge Wells, third, with very good fruit. Mr. S. Pullman, gardener to E. B. Sheridan, Esq., Frampton Court, Dorchester, won the chief prize in the eight dish class with very fine examples of Grapes, a capital Pine, Melons, Peaches, Nectarines, Pears, Plums, Bananas, Apricots, Figs, and Filberts; Mr. C. J. Goldsmith, gardener to Mrs. C. A. Hoare, Beckenham, was second, with excellent Grapes, and other fruit well finished and staged; the third prize falling to Mr. J. Bolton, Coombe Bank, Sevenoaks, with very good dishes throughout.

**GRAPES.**—These were far above the average, some of the classes remarkably fine, and judging them was no easy task, especially where size was in conflict with quality. In one or two instances the decisions did not meet with unanimous approval, and in cases of doubt the expressions of good cultivators indicate that it is easier to err in giving the verdict in favour of size rather than quality.

Only one collection of twenty bunches in ten varieties was staged—namely, by Mr. H. W. Ward, and in recording the award some mistake seems to have been made, for the card placed on the exhibits proclaimed, to the surprise of not a few gardeners, that the third prize only was adjudged, but in the official list of awards printed in the Palace we find, "First Mr. Ward, second and third no competition." If Mr. Ward receives £8 offered as the first prize he may consider himself lucky, but at the same time the merit of the collection was underestimated on the card. The varieties were Alnwick Seedling, Madresfield Court, Foster's Seedling, Mrs. Pince, Muscat of Alexandria, Gros Maroc, Trebbiano, Alicante, Buckland Sweetwater, and Lady Downe's. In these sensational classes, in which few can enter, the produce is never so good as in the smaller classes, and though Mr. Ward's Grapes were above the average, and, considering the number, highly creditable, yet no one could pretend to say the £18 provided in the twenty-bunch class brought out anything like such fine Grapes as the £9 (in three prizes) did in the class for two bunches each of five varieties. Here Mr. J. Harvey, gardener to J. Watson, Esq., Myskyns, Ticehurst, was the chief winner with good Gros Colmans and Muscats, splendid Black Hamburgs, enormous berried Gros Marocs, and unusually large Lady Downe's. Mr. A. Smith, gardener to W. H. Sewell, Esq., Loughton, Essex, was an excellent second with very fine Alicantes and Gros Colmans, excellent bunches of Muscat Hamburg, fairly good Madresfield Court, and rather weak Muscats. Mr. W. Pratt was third, his Gros Marocs being splendid, but a "falling-off" in the other varieties.

There was good competition with three bunches of Black Hamburgs, Mr. J. Bny, Tewkesbury Lodge, Forest Hill, being undoubtedly first with large, full, well-shaped bunches of fine berries. Mr. T. Osman, gardener to L. J. Baker, Esq., Chertsey, was fortunate in the second award with large, loose "sprawling" bunches of small, yet well coloured, berries. Mr. C. Warden, third, with smaller bunches but much larger berries, though in one bunch a trifle deficient in colour. Mr. R. Gray, gardener to Earl Stanhope, Chevening, Sevenoaks, well won the first position with Muscats, his bunches weighing about 4 lbs.; they were beautifully shaped, and the berries large, uniform in size, and well finished. Mr. George Duncan, gardener to C. J. Lucas, Esq., Warnham Court, Horsham, was placed second with very large, handsome, and well filled bunches, weighing probably 6 to 7 lbs., but the berries, though good, certainly lacked finish, and the majority of cultivators present preferred the smaller (3 lb.) bunches, with their good and well ripened berries of Mr. Pratt that were accorded the third prize. In the Gros Maroc class the prizes went respectively to Mr. J. Harvey, Mr. J. Wells, Windsor Forest, Bucks, and J. Timms, gardener to Mr. Parrott, New Barnet. In no Grape has such an advance been made in size of berry. The bunches were in no instance large, but the berries remarkably fine and well finished throughout. Mr. J. H. Goodacre was the premier exhibitor of Madresfield Court, his bunches being large and full, berries of great size and regular. Second, Mr. W. Jupp, gardener to J. Boulton, Esq., Eastbourne, with medium size bunches and grand berries. Third, Mr. J. F. Jordan, gardener to B. Foster, Esq., Witley, Surrey, with well finished fruit. The Alicante class was splendidly filled by eleven exhibitors. The first prize was well won by Mr. J. Harvey with perfectly shaped full 4 lb. bunches of uniformly sized and admirably finished berries. Mr. C. Griffin, Coombe Bank, Kingston-on-Thames, second, with heavy bunches, but insufficiently thinned; and Mr. Osman third, with smaller bunches but larger yet not equally coloured berries. In the class for white Grapes, Muscat of Alexandria excluded, Mr. F. Hicks, gardener to John Hol-



lingworth, Esq., Turkey Court, Maidstone, was easily first with long, well-filled bunches of Canon Hall; Mr. Bury, second, with Foster's Seedling; and Mr. T. Osman, third, with Mrs. Pearson, the bunches in both cases large but berries small, and little to choose between them. In the "any other black" class, Mr. T. Osman was placed first; Mr. Harvey second with Lady Downe's; and Mr. C. J. Goldsmith third with Black Prince. There was good competition in the class for a basket of black Grapes, the first prize being awarded to Mr. Howe, gardener to H. Tate, Esq., Streatham Common, for a good pile of well finished Black Hamburgh, the second to Mr. G. Duncan, for a basket of highly finished Alicantes, and the third to Mr. J. Harvey, Ticehurst, who had the same variety. For the best basket of white Grapes Mr. R. Gray was placed first with well ripened Muscat of Alexandria; Mr. Goldsmith second, and Mr. Pratt third with the same variety. The Grapes throughout were decidedly above the average as seen at the best shows, and highly creditable to the several cultivators.

The classes for the other kinds of fruit were well filled, and in most the competition very keen. The Peaches and Nectarines were remarkable for their size and high colour, especially those exhibited by Mr. W. H. Divers, who took the chief prizes for these fruits. Plums were not so large and fine as we have seen them in other years, the dry season, no doubt, accounting for that.

The first prize for four dishes of Peaches was awarded to Mr. W. H. Divers, gardener to J. T. Hopwood, Esq., Ketton Hall, Stamford, for excellent examples of Bellegarde, Crimson Galande, Early Crawford, and Dagmar. The second to Mr. J. Edmonds, Bestwood Gardens, Arnold, Notts, and the third to Mr. W. Smith, Neville Court Gardens, Tumble Wells. In the corresponding class for four dishes of Nectarines Mr. Divers was again first with fine fruit of Victoria, Dryden, Lord Napier, and Rivers Orange; Mr. J. Edmonds second; and Mr. C. J. Goldsmith third. Mr. Divers was also awarded first for a single dish of Peaches, showing a fine highly coloured dish of Crimson Galande. The second was awarded to Mr. F. Day, gardener to W. S. Gover, Esq., Casino House, Herne Hill, for a good dish of Prince of Wales, and the third to Mr. G. Holliday, gardener to J. Norris, Esq., Castle Hill, Bletchingley, for a dish of Violette Hâtive. For a single dish of Nectarines Mr. S. Pullman was first with a good dish of Pine Apple; Mr. J. Ridout, Reigate, second with Lord Napier; Mr. Divers third with a dish of highly coloured but smaller fruit of Rivers' Orange. In the next class for six dishes of Peaches and six dishes of Nectarines, distinct kinds, Mr. Divers was first with Dagmar, Dr. Hogg, Violette Hâtive, Early Crawford, Crimson Galande, and Bellegarde Peaches, and Pine Apple, Dryden, Victoria, Rivers' Orange, Lord Napier, and Albert Victor Nectarines; Mr. A. Waterman, gardener to H. A. Brassey, Esq., Preston Hall, was second, and Mr. C. J. Goldsmith, third.

Melons were represented by eighteen exhibits in each of the classes for a single fruit. The first prize for a green-flesh being won by Mr. A. Bolton, Montreal, Sevenoaks, with Sutton's Horticultural Prize; the second by Mr. J. H. Goodacre, with Best of All, and the third by Mr. H. W. Ward, with Hero of Lockinge. The first for a scarlet-fleshed was taken by Mr. Goodacre, with Read's Scarlet; the second by Mr. Ward, with Blenheim Orange; and the third by Mr. W. Sullivan, gardener to H. B. Kohler, Esq., Fawkham Manor, Dartford, with Veitch's Perfection.

Plums.—In the class for four dishes of Plums, any varieties, Mr. J. Neighbour, gardener to E. J. Wythes, Esq., Cbislehurst, was awarded first; Mr. J. Bolton, Coombe Bank Gardens, Sevenoaks, second; Mr. A. Bolton, third. For four dishes, green or yellow varieties, Mr. J. Wells, Windsor Forest, was first; Mr. H. W. Ward second; and Mr. C. J. Goldsmith third. The first for four dishes, purple, Mr. G. Holliday was first; Mr. Ward, second; and Mr. E. Chadwick, gardener to E. M. Nelson, Esq., Hanger Hill House, Ealing, third. Figs were very good, the prizes being taken by Mr. J. Butler, North Lancing, Mr. J. Wallis, Keele Hall, and Mr. Howe, Streatham Common, in the order of their names.

Apples and Pears were fairly represented, although many of the early varieties were affected with the maggot, which appears to be very prevalent this year. For twelve dishes of Apples, six kitchen and six dessert kinds, Mr. A. Waterman was first, Mr. J. Butler second, Messrs. G. & J. Lane, St. Mary's Cray, third. For three dishes of Apples, ripe, Messrs. G. & J. Lane, was first, showing Red Astrachan, Shakespeare, and Duchess of Oldenburg; Mr. S. T. Wright, gardener to C. Lee Campbell, Esq., Glewston Court, Ross, second with Worcester Pearmain, Lord Suffield, and Yorkshire Beauty; and Mr. A. Waterman third with Red Quarrenden, Red Astrachan, and Duchess of Oldenburg. In the class for ten dishes of Pears Mr. Butler was first with a good fruit, Mr. Goldsmith second, and Mr. Waterman third; and for three dishes of ripe Pears Mr. J. Butler was first with good examples of Windsor, Clapp's Favourite, and Beurré Goubault; Mr. A. Waterman second with Beurré d'Amanlis, Beurré Giffard, and St. Jule Luizot; Mr. J. Bolton third with Williams' Bon Chrétien, Jargonelle, and Doyenné Boussoch.

There were nine competitors for six dishes of Tomatoes in distinct varieties, and the successful exhibitor was Mr. C. Waite, gardener to Colonel the Hon. W. P. Talbot, Glenhurst, Esher, with heavy fruit of The Mikado, large, magenta tinted; Reading Perfection, fine; Carter's Perfection, Laing's Pedigree, Hathaway's Excelsior, and Burpee's Cardinal. The second was awarded to Mr. C. J. Goldsmith for an excellent collection, and the third to Mr. J. W. Silver, nurseryman, Streatham, Silver's Invincible being one of the finest Tomatoes in the Show.

MISCELLANEOUS.—Messrs. T. Rivers & Son, Sawbridgeworth, exhibited a group of small orchard house trees in pots loaded with fruit and in the best of health; these formed an interesting feature in the Exhibition; the group was faced round with good dishes of Grapes, Peaches, Apples, and Pears, and other kinds of fruits of very excellent quality. Messrs. J. Veitch and Sons, Chelsea, also exhibited a fine group of somewhat larger trees in full fruit in pots, chiefly consisting of Peaches and Nectarines.

CUT FLOWERS.—In addition to the Fruit Show the Palace authorities offered prizes for cut flowers other than Dahlias. Gladioli were the leading feature. In the open class Mr. A. Campbell of Gourock placed 150 and Messrs. J. Burrell & Co., Cambridge, about 180 spikes in competition, the prizes being awarded in the order named, but the famous Scottish grower had by no means an easy win. In the amateurs' classes the Rev. H. H. D'Ombrain, Westwell Vicarage, Ashford, far out-distanced other competitors with his eighteen splendid spikes, the colours of the flowers being

particularly bright and clear. The remaining prizewinners were Mr. W. H. Aphorpe, Cambridge, and Mr. A. Whitton, Bedale. Asters were plentiful, but not quite so good as usual. Messrs. Saltmarsh & Son, Chelmsford, were decidedly first with both Quilled and French kinds, the remaining winner being, for the former, Mr. G. Cooper, Chippenham, and Mr. H. Humpbries, Kington Langley, Wilts; for the latter Mr. W. J. Janes, Lark-hall, Bath, and Mr. S. Cooper. Hollyhocks were very poor, and we are quite sure there were thousands better in the country. It would not perhaps be a bad venture to offer prizes for seedlings or unnamed varieties, the same as for Asters, the vast majority of Hollyhock plants being raised from seed, and flowers from good strains quite equal several of those staged that were named. These flowers used to be effectively shown in spikes inserted in pots of sand, and the custom is worthy of resuscitation, allowing both named and unnamed varieties to be eligible for competition. The date of the Show was, however, perhaps too late for these flowers, considering the heat of the summer. They want encouragement, and to bring them out in greater force is to give latitude to exhibitors, then greater competition and eventually better quality would follow. Very good collections of stove and greenhouse flowers were staged by Mr. J. Prewett, Hammersmith; Mr. H. James, Norwood; and Mr. A. Gibson, gardener to T. F. B. Atkins, Esq., Halstead Place, Sevenoaks. Messrs. Davis & Jones, Camberwell, won the first prize offered for a collection of summer-flowering Chrysanthemums, an extra prize being granted to Mr. W. Piercy, who inadvertently contravened the conditions as to size of pots; and Messrs. Sanders, Charlewood Park, Crawley; Spinks, Honley; and Lambert, Herne Hill, secured the prizes for Cockscombs in the order named.

In the miscellaneous class extra prizes were awarded to Messrs. Paul and Son, Cheshunt, for a great display of Roses; to Messrs. Cannell & Sons, Swanley, for an imposing representative collection of Dahlias, double Begonias, and other flowers; to Messrs. J. Laing & Co., for baskets of Begonias lifted from the open ground—a dazzling group—the plants dwarf and vigorous, and the varieties of superior merit; and to Mr. W. Gordon for a splendid group of Lilliums.

Certificates were granted to Messrs. Davis & Jones for Chrysanthemum Mrs. John R. Pitcher, white, with large blooms and broad florets, apparently as early and free as Madame Desgrange; and to Mr. George Miles for C. Mrs. Burrell, a primrose coloured form of the variety last named, and very effective.

#### NATIONAL DAHLIA SHOW.

THE great Exhibition of the National Dahlia Society was held in conjunction with the fruit Show above referred to, the stands being arranged, as in one or two previous years, in the central avenue of the Palace—a grand promenade with ample room for exhibits and spectators alike. It might not unreasonably have been expected that after so unpropitious a season the examples of this good autumnal flower would lack the high quality which distinguished prize Dahlias from the best growers in ordinarily favourable seasons; but, on the contrary, the blooms generally were in splendid condition. Show and Fancy flowers were wonderful, taking the long drought into consideration, being of good size and form, the petals substantial, and the colour everything that could be desired. Single flowers were perhaps hardly up to the mark, and all the classes were not well filled, but the Pompons were grand, and made quite a remarkable feature. Cactus varieties were also shown plentifully and well; these are unmistakably "creeping up." The Show was undoubtedly one of the best—if not the best—ever held. Details of the awards are appended.

NURSERYMEN'S CLASSES.—Some alterations were this year made in the schedule. The principal classes stipulated for seventy-two blooms instead of forty-eight, as in former years; and instead of separate classes being devoted to Show and Fancy blooms, all were to be composed of Show and Fancy flowers intermixed. In the great class for seventy-two, not fewer than thirty-six varieties or more than two blooms of any one variety, there were five competitors, and the always formidable task of adjudicating proved more than usually difficult and tedious. Eventually a close struggle for the coveted first prize resulted in a victory for Mr. W. Boston, Cartorpe, Bedale, Yorks, an old exhibitor of Dahlias. It is significant that the great prize at this and the National Rose Society's Show were both won by blooms from the same locality, and that a northern one. Mr. Boston's was a highly meritorious collection, comprising many magnificent blooms, and all noteworthy for perfect contour and purity of hue. The varieties shown were as follows, the names being given as read from left to right:—Back row—Henry Walton, Miss Cannell, Jas. Cocker, J. B. M. Camm, Mrs. F. Foreman (a beautiful bloom), J. T. Saltmarsh, Prince of Denmark, Mrs. Sanders, J. B. M. Camm (self, 2), W. Slack, John Wyatt (very fine), Goldfinder, Jas. Cocker, Criterion (a splendid flower), Henry Walton, Burgundy (2), Mrs. Gladstone, Artist, Jas. O'Brien, Earl of Ravensworth, Eccentric, and Rev. J. Goodday. Middle row—Mrs. Gladstone, Professor Fawcett, Mrs. Langtry, Jas. Stephen, Miss Henshaw, John Forbes (self), Duchess of Wellington, Jos. Ashby (excellent), George Paul, Eccentric, Shirley Hibberd, Mrs. F. Foreman, Thos. Goodwin, Miss Henshaw, Hugh Austin, Gladys Herbert, Rev. J. Goodday, Goldfinder, Hope, Mrs. Langtry, G. Barnes, Criterion, W. Rawlings, and Sunbeam. Front row—John Wyatt, Sunbeam, Mrs. Harris, Bessie Ford, Shirley Hibberd, Mrs. J. R. Jefford (2), Chorister, a sport, Galatea, General Gordon, Annie Neville, Miss Large, H. W. Ward (2), Henry Bond, C. Wyatt, Jas. Stephen, W. B. Pritchard, O. E. Cooper, Hon. Mrs. W. P. Wyndham, Professor Fawcett, Mrs. G. Rawlings, and Prince of Denmark. Mr. Charles Turner, Royal Nurseries, Slough, was the exhibitor of the second prize collection, and though defeated he was very far from being disgraced, his blooms being in every way excellent. One or two flowers were lacking in size, hence lost a point or two, but all were wonderfully substantial and fresh. Annie Pritchard, Crimson King, Constancy, and Mrs. W. Slack were noteworthy examples. Messrs. Keynes, Williams & Co. Salisbury, showed well, though hardly, perhaps, in their usual form, third place being assigned to them. Messrs. Heath & Son, College Nurseries, Cheltenham, secured the remaining prize. Mr. Turner again showed splendidly with forty-eight blooms, and improved on his previous position by securing the premier award from seven opponents. The varieties shown were as follows:—Back row—Goldfinder, Progress, Crimson King, very fine; T. J. Saltmarsh, Wm. Rawlings, a seedling; Champion Rollo,



Mrs. Henshaw, Mrs. Langtry, Colonist, Constance, Lustrous, Mrs. Jeffard, excellent; Geo. Rawlings, Mrs. Douglas, and Miss Cannell. Middle row—John Standish, Hy. Glasscock, a grand bloom; Clara, Henry Keith, Mrs. Gladstone, beautiful; Victor, J. B. Service, Jas. Stephen, Jas. Cocker, Annie Pritchard, Imperial, Mrs. W. Slack, Rev. J. B. M. Camm, Rosetta, J. N. Keynes, and Prince of Denmark. Front row—Sunbeam, Mrs. S. Hibberd, Harry Turner, Mrs. Harris, excellent; Herbert Turner, Prince Bismarck, Ethel Britton, Lady Wimborne, Ovid, a scarlet seedling, very good; Leah, Defiance, Flag of Truce, Diadem, and Royalty. Messrs. Keynes, Williams and Co., followed, Richard Dean, Crimson King, Hy. Glasscock, and Thos. Hobbs being particularly fine in this stand. Mr. J. Walker, Thame, was an excellent third, and Mr. M. J. Saule, The Vine, Sevenoaks, fourth. Mr. G. Humphries, Kington Langley, Chippenham, was to the fore with twenty-four blossoms. He had Jos. Ashby, Edmund Boston, John Wyatt, T. J. Saltmarsh, and The Countess in excellent condition. Messrs. Saltmarsh and Son, The Nurseries, Chelmsford, were second, their blooms being of medium size, shapely, and pure; Ethel Britton was well shown, as were Goldfinder and Mrs. Harris. Mr. J. Walker was awarded the third prize, and Messrs. Harkness & Sons, Bedale, the fourth, there being six contestants. Messrs. Saltmarsh were first with twelve blooms, followed by Messrs. Harkness, Humphries, and Jos. Gilbert & Son, St. Margaret's Nursery, Ipswich, in the order named. The first prize stand was composed of J. Standish, Mrs. Saunders, Miss Cannell, Shirley Hibberd, Ethel Britton, W. Rawlings, T. J. Saltmarsh, Mrs. Harris, J. Henshaw, Constance, James Dick, and Mrs. D. Saunders. There were six lots.

**AMATEURS' CLASSES.—Show Varieties.**—Mr. R. Petfield, gardener to A. J. Thornhill, Esq., Buckdean, took the first prize for twenty-four blooms after a good fight with Mr. Thos. Hobbs, Lower Easton, Bristol. Mr. Petfield's blooms were only moderate in point of size, but they were an exceedingly fresh and level lot. The following were the varieties.—Back row—Earl of Ravensworth, Geo. Rawlings, Sunbeam, Jos. Ashby, Mrs. Gladstone, John Standish, R. T. Rawlings, and Imperial. Middle row—Thos. Hobbs, J. T. Saltmarsh, Rev. J. Goodday, Mrs. S. Hibberd, Jas. Cocker, Miss Cannell, J. W. Lord, and Goldfinder. Front row—Constancy, John Henshaw, J. B. Service, J. Wyatt, Mrs. Dodds, Prince of Denmark, Mrs. Harris, and Jas. Stephen. Mr. Hobbs' otherwise excellent stand was marred by one or two weak blooms. Mr. H. Glasscock, Rye Street, Bishops Stortford, took the third prize, the veteran's blooms displaying all his customary finish. These were the only competitors, though a fourth prize was offered. There was no such paucity of entries in the class for twelve blooms, ten sending in their names for the four awards. Mr. J. T. West took leading honours, showing capital examples of J. T. West, Mrs. Rawlings, Mrs. Langtry, and Harry Keith (back row); Prince of Denmark, Mrs. Gladstone, Jas. Stephen, and J. T. Saltmarsh (middle row); T. T. Rawlings, Lord Chelmsford, Ethel Britton, and Prince of Purples (front row). Mr. B. Clarke of Shottesham, All Saints, Norfolk, followed with Messrs. A. Whitton, Aisken, Bedale, and H. Steer, Southwood Road, New Eltham, respectively third and fourth. There were twelve competitors with six blooms, this number being well within the strength of most amateurs. Mr. S. Cooper, The Hamlets, Chippenham, won with fresh examples of Jas. O'Brien, Goldfinder, Picotee, Hope, Jas. Cocker, and Mrs. Gladstone. Mr. A. T. Walton, The Apiaries, Orpington, following with a capitals' stand; Messrs. T. Anstiss, Brill, Thame; and W. Mist, Ightham, Sevenoaks, taking third and fourth prizes in the order given.

**FANCY VARIETIES.**—Mr. West was first with twelve, staging the following varieties: Back row—Jas. O'Brien, H. Glasscock, Duchess of Albany, and Jessie McIntosh. Middle row—Hy. Eckford, Professor Fawcett, Chorister, and Rebecca. Front row—Egyptian Prince, Mrs. N. Halls, Hugh Austin, and Edward Boston. Mr. R. Petfield followed closely with an excellent stand, third and fourth prizes going to Mr. Glasscock, and Mr. Steer respectively. Mr. S. Cooper won with six blooms, followed by Messrs. W. H. Smith, Shrivvenham (second), B. Clarke (third), and T. Anstiss (fourth).

**OPEN CLASSES.**—There were four classes for Show Dahlias, five grouped by colour, six blooms of distinct varieties being asked for in each case. Messrs. Keynes, Williams & Co. won from six opponents with dark varieties, showing H. Glasscock, Wm. Rawlings, Richard Dean, Imperial, Ethelwin (seedling), and Victor. These were a capital lot. Messrs. Saltmarsh took second place, also with good blooms, the remaining awards going to Mr. C. Turner, Mr. B. Clarke, and W. Boston (extra prize). Mr. M. J. Seale won with light blooms, showing Mrs. Shirley Hibberd, Annie Neville, Mrs. Gladstone, Flag of Truce, Ethel Britton, and Julia Wyatt. This was a highly pleasing stand. Messrs. Keynes, Williams & Co., J. Walker, and Saltmarsh and Son were respectively second, third, and fourth, six showing in all. Messrs. Saltmarsh won with six tipped flowers, having Royal Queen. Mrs. Saunders, J. T. West, Mrs. Harris, Mrs. N. Halls, and T. J. Saltmarsh, Messrs. Keynes, Williams & Co. were second, Mr. Turner third, and Messrs. Rawlings Brothers, Old Church, Romford, fourth. There were four other lots. Six competed with striped flowers, Messrs. Keynes, Williams & Co. winning with Rebecca, Pelican, Eric Fisher, a seedling, Chorister, and Gaiety, followed by Messrs. Rawlings, Turner, and Walker in the order named. Six varieties of decorative Dahlias, including Cactus varieties, six blooms to a bunch, were best shown by Messrs. Keynes, Williams & Co., who staged Mrs. Tait, Empress of India, Constance, Juarezi, Mrs. Hawkins, and Cochineal. Messrs. J. Cheal & Sons, Lowfield Nursery, Crawley, Sussex, were second, Mr. Turner third, and Mr. M. V. Seale fourth, two others competing.

As previously noted the Pompon varieties formed a fine feature. The winner of the first prize for twenty-four varieties was Mr. Charles Turner. The Slough collection was undoubtedly one of the best ever brought together, the following being the varieties:—Back row—Darkness, White Aster, Fanny Weiner, Gazelle, Gem, Golden Gem, Lustrous, and Lady Blanche. Middle row—Cupid, Isabel, Mdme. V. Faconet, Rosalind, G. F. Jungker, Professor Bergeat, Titania, and Garnet. Front row—Thos. Moore, Ernest, Little Princess, Little Willie, Henriette, Fashion, Eccentric, and William Carlisle. Bunched with their own foliage these were charming. Messrs. Keynes, Williams & Co. also had a nice collection and were placed second, followed by Messrs. Cheal & Son third, and Ware fourth. Messrs. J. Burrell & Co., Howe House Nurseries, Cambridge, won with twelve, an excellent lot; Mr. J. Henshaw, Rothamsted Cottage, Harpenden,

J. Gilbert & Son, and Humphries following in the order given. There were three other lots. Five competed with six blooms, the prizes being awarded to Messrs. Glasscock (first, with a fine lot), West (second), W. H. Apthorpe, Albion Brewery, Cambridge (third), and A. Phillbrick, gardener to J. Smith, Esq., Hill House, Romford (fourth). The latter class, it may be said, was reserved for amateurs. There was but one exhibitor of twenty-four single varieties, Messrs. Cheal, who received the chief award. They had a better stand than might have been looked for in this trying season. The varieties were as follows:—Back row—Alba perfecta, Brutus, Mr. Kennett, Mrs. Bowman, Primrose, Amos Perry, Excelsior, and Edith. Middle row—Formosa, Hy. Irving, Alfonso, Beauty of Uplands, Negress, Duchess of Westminster, Miss Linnaker, and Silver King. Front row—Jas. Kelway, Acquisition, Cetewayo, Helena, Hugo, Sunset, Paragon, and Miss Cameron. Mr. T. S. Ware, Hale Farm Nurseries, Tottenham, was to the fore with twelve varieties, all of superior quality well staged; Messrs. Paul & Son, Old Nurseries, Cheshunt, were second; Messrs. J. Gilbert & Son, third; and Mr. Seale, fourth. There were no competitors in the class for six varieties.

**SPECIAL PRIZES.**—The Turner Memorial prize, presented by nineteen subscribers, and to be won twice by the same exhibitor before becoming his property, was the first of these. The present was the third occasion of its being offered, the previous winners being Messrs. Glasscock and West. This year the latter was again the winner, hence the cup now becomes his property. He had a very fine stand, as, indeed, were all those in competition. Twelve Show and six Fancy varieties were asked for—Harry Keith, Mrs. Gladstone, Mrs. Keith, J. W. Lord, J. T. West, Prince of Denmark, T. J. Saltmarsh, Geo. Rawlings, Sunbeam, Mrs. S. Hibberd, Mrs. Langtry, and General Gordon representing the former; and Hugh Austin, Rev. J. B. M. Camm, Jas. O'Brien, Henry Glasscock, Hercules, and Professor Fawcett the latter. Five classes were provided for the Veitch Memorial prizes, the award in each being a medal and £2 10s. in cash. For nine self-coloured Show varieties Mr. H. Glasscock won with good examples. A similar number of parti-coloured show flowers also finding this exhibitor successful. Mr. J. Henshaw was successful with Pompons, and Mr. H. Vincent, gardener to Mr. Hart, Reymer, Sussex, with decorative varieties.

First-class certificates were awarded to the following novelties.

**SHOWS.**—*Purple Prince* (Turner).—Well-formed symmetrical blooms; colour crimson, with a glistening purple sheen; very distinct and pleasing.

*Malcolm* (Turner).—A large, smooth, splendid flower, soft scarlet suffused with orange, very bright.

*Royalty* (Turner).—Medium size, broad primrose florets, faintly tipped with crimson.

**FANCY.**—*Frank Pearce* (Rawlings).—Medium-sized blooms of excellent form; colour deep rosy pink, faintly suffused with purple and marked with clear maroon stripes.

**DOUBLE POMPONS.**—*William Carlisle* (Turner).—Very neat and compact; colour lilac, heavily tipped with crimson.

*Iseult* (Keynes, Williams & Co.).—A charming miniature; colour clear rich yellow.

*Janet* (Keynes, Williams & Co.).—Colour reddish terra cotta, very soft and distinct; form excellent.

**CACTUS.**—*Blazer* (Cannell).—Colour a distinct hue of scarlet, soft, yet bright and very effective.

**SINGLE.**—*Excelsior* (Cheal).—White, with a broad margin of deep lilac; form excellent.

*Miss Roberts* (Ware).—A perfectly formed flower of small to medium size, and pure soft yellow in colour.

*Miss Henshaw* (Ware).—A distinct and charming variety; colour very pale sulphur and form excellent.

*Miss Gordon* (Ware).—Crimson, with orange yellow centre; very bright.

Miscellaneous exhibits in the Dahlia section were not numerous. Messrs. Daniels Brothers, Norwich showed several stands of Zonal Pelargoniums which were much admired, the trusses being very fine. Messrs. Cheal and Son exhibited an attractive collection of Dahlias and hardy flowers.

## NEWCASTLE-ON-TYNE SHOW.

AUGUST 31ST, SEPTEMBER 1ST AND 2ND.

A REVIEW of the chief feature of this highly successful Show was given last week, but it deserves a more detailed reference to the leading classes and exhibitors than could be then afforded. It is very gratifying to be able to state that the financial results of the Exhibition were as satisfactory as the horticultural portion, for the attendance of visitors was exceptionally large. On the opening day, Wednesday, 32,481 persons were admitted, on Thursday the number was 34,153, and on Friday 21,046, or a total for the three days of 87,680. The arrangement was that the Horticultural Society should have a share in all money taken at the gates, and it is believed that this will not only clear off the outstanding debt but leave a substantial balance to the credit of the Society. The executive deserve much praise for the energy and tact displayed in the arrangements of this Show, and it is only just to state that valuable assistance has been afforded by the Mayor, Sir Benjamin C. Brown, Alderman Thomas Gray, and other influential friends of the Society. The courteous Secretary, Mr. Jas. J. Gillespie, and the Committee have also worked well in furtherance of the scheme, and they have satisfaction of knowing their efforts have been fully appreciated. A good balance in hand will perhaps encourage the Committee to attempt another Chrysanthemum show, though it is too late in the present season; still, from what we know of the district, we should think there would be little difficulty in obtaining a creditable exhibition another year.

**FRUIT.**—Although the Exhibition was a good representative one in fruit, flowers, and plants, the chief horticultural interest centred in the first named, and the display was, as we have previously stated, a very extensive one. The special Jubilee prize class for fifty dishes occupied nearly the whole of one side of the central table in the first marquee, and it is not likely that so many dishes of fruit would have been obtained in any other way than by offering a sensational prize. There were necessarily in the 150 dishes some fruit of inferior quality, for the strongest exhibitor must find it difficult to make up such a number. It was also a mistake excluding Pines, for any cultivator who was likely to enter in such a class would grow at least a few Pines, and they would have added much to

the collection. In smaller classes, where it is desired to obtain as many competitors as possible, it is always advisable to keep Pines out, but it was not difficult in the case under notice to forecast how many exhibitors would stage. The contest was a close one between Mr. J. Hunter, gardener to the Earl of Durham, Lambton Castle, and Mr. J. McIndoe, gardener to Sir J. W. Pease, Bart., M.P., Hutton Hall, Guisborough, but Mr. Hunter won by several points, his Grapes, Apples, Pears, Peaches, Nectarines, and Melons, including good specimen fruits. The Grapes comprised large handsome bunches of Alicante, Cannon Hall Muscat with fine berries, Gros Guillaume, large bunches of berries, but somewhat rubbed; Muscat of Alexandria, good bunches, medium berries, fairly coloured; Black Hamburg, fine bunches and colour, but medium size berries; and Trebbiano, very large heavy bunches. The Melons were capital specimens of Scarlet Premier, Lord Strathmore, and Best of All. The Pears included large clean fruits of Durondeau, Benrre Giffard, Williams' Bon Chrétien, Beurré Diel, Brockworth Park, Pitmaston Duchess, Souvenir du Congrès, and an unnamed variety. The Apples were White Calville, Cellini, Worcester Pearmain, Lord Suffield, Jefferson, Ringer, Ribston Pippin, and an unnamed dish. The Peaches were Royal George and another variety, the fruits large in both cases; the Nectarines Pitmaston Orange and Pine Apple. Plums were fine white and yellow Magnum Bonum, Denbigh and Prince Englebert being the varieties shown. There were also Early American and Moorpark Apricots, Osborn's Prolific and Brown Turkey Figs, Red, White and Black Currants, two dishes of red and green Gooseberries, two dishes of Cherries, Citrons, Lemons, and fruits of *Cycas revoluta*, the last named occasioning a little criticism as to its admissibility. Mr. J. McIndoe also had some good Grapes; his Alicantes were well coloured, Gros Colman was also finely represented. Muscat of Alexandria, Black Hamburg, Gros Guillaume, and Buckland Sweetwater were included; the bunches good, but some seemed to have suffered in transit, and were somewhat rubbed. Handsome fruits of Golden Eagle and Violette Hâtive Peaches were shown, together with Apples and Pears; of the former Peasgood's Non-such and Maiden's Blush were exceptionally fine. Two good dishes of Tomatoes were included, and a large bunch of Bananas, but green, and this weakened the collection materially. Scarlet Premier Melon, Vicomtesse Hericart de Thury Strawberries, and some fine Citrons were the other leading dishes. Mr. J. H. Goodacre, gardener to the Earl of Harrington, Elvaston Castle, Derby, was third, and was not exhibiting in his usual style. His Grapes were mostly well coloured; Madresfield Court, Muscat Hamburg, Foster's Seedling, Muscat of Alexandria, Black Hamburg, and Trebbiano were the varieties, Barrington and Downside Peaches being also excellently shown. It was rather surprising that some of the choice exotic fruits occasionally grown under glass in large gardens, such as Guavas, *Passiflora edulis*, and *Eugenia Uguai* were not shown in these collections, as they would have possessed more value than indifferent Gooseberries, and would not have been open to any doubt, like the *Cycas* fruits and Tomatoes.

In the classes for eight and four dishes of fruit respectively there was keen competition, nearly one hundred dishes being entered in the two classes. Mr. Hunter won first honours with eight dishes amongst seven competitors, his collection being distinguished by the even quality of the fruits, and this class altogether comprised some of the best in the Show. The varieties were Smooth Cayenne Pine Apple, finely developed; Golden Queen, Golden Champion, and Gros Colman Grapes, good solid well-finished bunches; Best of All Melon, Goshawk Peaches, Williams' Bon Chrétien Pears, and Worcester Pearmain Apples. Mr. R. Westcott, gardener to the Duke of Cleveland, Raby Castle, was a close second with capital Black Hamburg and Muscat of Alexandria Grapes, Raby Figs, Rivers' Early Elruge Nectarines, Peaches, and a Melon. Mr. John McIntyre, Woodside Gardens, Darlington, was third, Mr. McIndoe fourth, and Mr. R. Parker, gardener to John Corbett, Esq., M.P., Impney Droitwich, fifth, the last-named showing a large bunch of Muscat of Alexandria and a good Melon. With four dishes Mr. R. Westcott was a good first in a class of nine competitors, staging Muscat of Alexandria and Black Hamburg Grapes finely coloured, Williams' Bon Chrétien Pears, and Violette Hâtive Peaches; Mr. R. Parker was second with handsome bunches of Muscat of Alexandria Grapes, Blenheim Orange Melon, Noblesse Peaches, and Elruge Nectarines; Mr. Hunter was third, Gros Colman Grapes being the most telling dish. A class was provided for six hardy fruits and seven competitors entered, but the exhibits were not of unusual merit. Mr. John Short, gardener to Arthur Pease, Esq., Hammersknott, Durham, was well to the front, followed by Messrs. Westcott and Parker.

GRAPES.—The display of Grapes was a very extensive one, but the general quality was not quite so high as might have been expected, though there were many excellent samples. The class for six bunches not less than three varieties was a remarkable one, ten competitors entering, and the sixty bunches shown formed a fine array. Mr. J. Witherspoon, Red Rose Vineries, Chester-le-Street, gained a victory in this class, showing exceptionally well finished bunches of Gros Maroc, Black Hamburg, and Alicante. The two bunches of the last-named were grand specimens, beautifully proportioned, the berries good, and bearing a fine dense bloom, very rarely are such handsome Grapes seen at exhibitions; Gros Maroc was also fine; and the Black Hamburg heavy bunches. Mr. Hunter followed with Muscat of Alexandria, Cannon Hall Muscat, and Gros Colman. Mr. McIndoe was third with Duke of Buccleuch, Black Hamburg, and Gros Colman; the fourth and fifth prizes going to Mr. W. Laidlaw, gardener to the Rev. J. Burdon, Castle Eden, Sunderland, and to Mr. R. Thompson, Roe Villa Gardens, Bedlington. The competition was also very strong with two bunches of Black Hamburg, no less than fourteen staging good samples. Mr. J. McIndoe won premier honours for even bunches and berries capably coloured; Mr. Goodacre was second with much larger bunches and good berries, but not quite so well coloured; Mr. W. Luck, Amble, being third with compact bunches. Mr. Witherspoon was first in the Alicante class with similar finely coloured samples to those in the other class; Mr. Heslop, gardener to J. J. Allison, Esq., Roker, Sunderland, was second with good bunches, but they had been rubbed, and this spoiled their appearance to a great extent; Mr. McIntyre was third, and there were four other exhibitors.

Eight competitors entered with two bunches of black Grapes, any other sort than those provided for in the special classes. Mr. J. McIndoe was first with Gros Colman, large in bunch and berry, and finely coloured.

Mr. Hunter was second with good specimens of Alnwick Seedling, Mr. Witherspoon following with Lady Downe's, of which the berries were small but well coloured. The same number of exhibitors entered with two bunches of Muscat of Alexandria, and the three winning pairs from Messrs. Hunter, Westcott, and Letts were creditable specimens, the first and second being distinguished by their good colour and clean berries. Of the four exhibitors of Buckland Sweetwater, Mr. Heslop won the first place with good bunches, Mr. Wm. Carrick, gardener to E. H. Ryott, Esq., Saltwell Grove, Gateshead, and Mr. Laidlaw following, the last-named having small but highly coloured bunches. For any other white variety Mr. Hunter led amongst six competitors with substantial specimens of Trebbiano, Mr. J. McIndoe was second with Foster's Seedling, well ripened, and Mr. Westcott third for Golden Champion with large berries. Mr. McIndoe had the heaviest bunch of Grapes, Gros Guillaume weighing 9 lbs., but not quite finished; Mr. Witherspoon followed with Alicante of good size.

MISCELLANEOUS FRUITS.—Peaches and Nectarines were numerous shown, twelve dishes of the former and ten of the latter being staged. Mr. Paul Blanchard, gardener to Dr. C. J. Gibb, Sandyford Road, Jesmond, was accorded first honours for fine fruits of Violette Hâtive. Mr. F. Nicholas, gardener to the Earl of Zetland, Upleatham, Yorks, secured the second place with Princess of Wales, and Mr. J. Thomson, gardener to W. G. Pawson, Esq., Shawdon Hall, Alnwick, was third with Noblesse. Mr. Goodacre had the leading Nectarines, Pine Apple. Mr. Wm. Jenkins, gardener to B. Cochrane, Esq., Aldin Grange, Durham, and Mr. J. Burrow, gardener to Sir John Lawson, Brough Hall, Catterick, were second and third with the same variety. Ten dishes of Apricots were shown, but the fruits were rather small. Mr. Short was first for Moorpark, followed by Mr. Westcott and Mr. Austin Lunt, Holm Hall Gardens, Yorks. Of twelve dishes of Cherries Mr. McIndoe had the best fine fruits of Bigarreau Napoleon, followed by Messrs. P. Blair and J. Hara. Apples were numerous, and a large proportion were Lord Suffield, Messrs. Parker, Chuck, and Short winning in the order named for culinary varieties. Dessert Apples from Messrs. Short, Parker, and Nicholas, and Pears from Messrs. Hunter, Parker, and Short, were well shown. Melons, Plums, Currants, and Tomatoes were also abundant. Mr. C. Bull, Down Gardens, Crediton, had the finest Pine Apple, a very handsome fruit of Smooth Cayenne, Mr. McIndoe, and Mr. Neil Black, Southend Gardens, Darlington, taking the second and third places.

PLANTS.—One of the marquees was well filled with specimen plants in competition, and they were remarkable in all the classes for their fresh healthy condition. The chief class for flowering plants was that for eight specimens, and in which Mr. E. H. Letts, gardener to the Earl of Zetland, Aske Gardens, Richmond, Yorks, won the honours with even, well flowered plants, 4 to 5 feet in diameter, of *Statiche profusa*, *Erica Parmentieriana rosea*, *Aitoniana superba*, and *Maruockiana*; *Allamanda grandiflora*, *Dipladenia amabilis*, and *Ixora Williamsi*. Mr. Thos. Suffield, gardener to Mrs. Kitching, Elm Field, Darlington, was a strong exhibitor in this class, running Mr. Letts very closely for the first prize; he was, however, placed second, his plants including an extraordinary specimen of *Oncidium flexuosum*, with scores of large panicles of flowers. *Dipladenia amabilis*, *Clerodendron Balfourianum*, and *Rondeletia speciosa* were all notable plants, the last a globular specimen flowering freely. Mr. J. Cypher, Cbeltenham, took the third place, a very unusual position for him, and it will give some idea of the merits of the exhibits, for all his plants were fresh and good as usual, though he had not brought his giants. The plants were *Allamanda Hendersouii*, *Statiche profusa*, *Ixora Duffii*, *Erica Marnockiana*, *Clerodendron Balfourianum*, *Ixora salicifolia*, and *Phenocoma prolifera* Barnesi, 6 feet in diameter. Mr. Adams, Swalwell, was fourth with well grown plants, but somewhat the worse for their previous travels. A class for six flowering plants was provided in Division B, from which nurserymen were excluded. Mr. F. Nicholas, gardener to the Earl of Zetland, Upleatham, Yorks, was a capital first in this class, showing a good plant and variety of *Anthurium Schertzerianum*, with *Allamanda nobilis*, *Bougainvillea glabra*, *Dipladenia amabilis*, and *Clerodendron Balfourianum*. Mr. R. Gardner, Dunston-by-Gateshead, was good second, his most remarkable plant being an extraordinary specimen of *Statiche imbricata*, 7 feet in diameter, in perfect health, and bearing a large number of large dark coloured trusses of flowers. Mr. Suffield was third with smaller plants. Mr. Adams exhibited well in another class for flowering plants, and had several uncommonly fine *Phenocomas*, one 6 feet in diameter and 4 feet high, being in grand condition, and as the productions of an amateur they were the more remarkable. Fuchsias were fairly represented by well flowered but not large plants.

The foliage plants occupied considerable space, as some very large specimens were contributed by the exhibitors in these classes. For eight specimens Mr. Letts secured the premier prize for gigantic specimens in vigorous health of *Encephalartos Altensteini*, *Kentia Forsteriana*, *Cycas revoluta*, *Stevensonia grandifolia*, *Kentia australis*, *Cycas circinalis*, and two grandly coloured *Crotons angustifolius* and *Johannis*, about 6 feet high each, nearly as much in diameter, and in splendid condition. Mr. A. Methven, gardener to T. Lange, Esq., Heathfield House, Gateshead, was a good second, his *Crotons* Queen Victoria and majestic being large handsome specimens; *Sabal umbraculifera*, *Zamia natalensis*, and a fine *Cordyline* were also included. Mr. McIntyre took the third place. For six foliage plants in Division B Mr. Nicholas was the most successful exhibitor, and he had a magnificent specimen of *Davallia fijiensis plumosa* which attracted much attention, it was 7 feet in diameter, in splendid condition, the fronds rich dark green, and large. Other notable plants were *Crotons Johannis* and Queen Victoria finely coloured; *Kentia Belmoreana*, *Cycas circinalis*, and *Chamaerops Fortunei*. Mr. McIntyre was second, having *Cycas revoluta* and *Phoenix rupicola* of great size.

Two classes were provided for six exotic Ferns, one in Division A, and the other in Division B. In the latter Mr. Nicholas was again successfully exhibiting excellent specimens of *Leucostegia immersa*, *Neottopteris australis*, *Dicksonia antarctica*, an unusually fine *Lomaria cycadefolia*, *Pteris scaberula* large and healthy, and *Gleichenia rupestris glaucescens* in good condition. Mr. McIntyre was second with *Davallia Mooreana*, 8 feet in diameter, and remarkably healthy amongst other good plants, Mr. Methven being third. In the other class Mr. H. Johnston, gardener to J. B. Hodgkin, Esq., Elm Ridge, Darlington, took the lead, also having



grand example of a Davallia Mooreana, 7 feet across. Mr. McIntyre was second, his Adiantums being handsome, especially A. farleyense. Mr. J. Luke Thornburn, gardener to G. H. Benson, Esq., Eden House, Sunderland, was third with smaller but clean healthy plants.

The groups of plants were very effective, but were marked by a great similarity in style, small well-coloured Crotons being freely employed. The first prize of £10 and the Society's silver medal was won by Messrs. Clark Brothers, Carlisle, for a light tasteful arrangement, in which Crotons, Begonias, Ferns, and Dracaenas predominated. Mr. McIntyre was also awarded a first prize for a bright and handsome group of similar design. Mr. H. Johnston, who was placed second, had a number of Crotons, Palms, Dracaenas, Adiantums, and Celosias freely and effectively arranged with a neat margin of Panicum variegatum. These groups were placed at the ends of the marquees, and, with the non-competing exhibits to be noted presently, constituted an admirable finish to the Exhibition as a whole.

**CUT FLOWERS, BOUQUETS, &c.**—The central marquee of the three was occupied with the cut flowers arranged on side stages, the bouquets, button-holes, wreaths, and dessert table decorations having a central stage extending the whole length of the tent. The exhibits were very numerous, and it would occupy too much space to particularise them all, but they formed one of the most interesting features of the Show to the general public, the tables being surrounded by a crowd of visitors on each of the three days. There were six competitors with dessert tables arranged in a space 10 feet by 5 feet 4 inches, the first prize being £10 and the Society's silver medal. A well-known and successful exhibitor in the north, Mr. M. D. Thompson, The Hermitage Gardeus, Chester-le-Street, was awarded this substantial honour in a keen competition, followed by Mr. J. R. Chard, Brunswick Nurseries, Stoke Newington, Mr. J. Cypher, and Mr. A. Methven, Gateshead, but there was considerable difference of opinion, as there often is in such classes, respecting the correctness of the awards. Mr. Cypher's table was unquestionably entitled to a better place than that awarded it, and it would have been more satisfactory if the Judges could have devoted more time to the class. Indeed, a staff of six Judges for so large a Show was inadequate. Messrs. Perkins & Son, Coventry, were successful in the classes for a basket of cut flowers, bridal bouquet, hand bouquet, and a ladies' spray, winning first honours in each case with their usual tasteful arrangements. Mr. Cypher had the best epergne of flowers, and Mr. Chard also won several prizes, together with Messrs. Lunt, Armstrong, Rutherford, Handyside, Robertson, Hewitt, and McDougall. Miss Dora Battensby also showed well in several classes, her bouquets and baskets being especially tasteful.

The cut flowers comprised some fine Gladioli from Messrs. Harkness and Son, Bedale, some of their spikes having sixteen large expanded flowers. Messrs. H. G. Brown, R. Greenwell, and Alex. C. Campbell were also prizetakers in the same class. Dahlias were capitally shown, several classes being devoted to them, including those in which the Turner Memorial prizes were offered. The best twenty-four Dahlias were shown by Mr. J. Spoor, Musgrave Cottage, Low Fell, Gateshead, who was awarded the first prize of £6 and Wood's Jubilee Memorial silver medal. Mr. Spoor is a well-known amateur florist at Newcastle, who competes successfully at many of the local shows in the district; his blooms were fine, of good substance, and rich clear colours. Messrs. N. Walker, H. Clark & Sons, Harkness & Son, Wm. Boston, and J. Walker followed in a large class. The Turner Memorial prizes for twelve Dahlias and twelve Roses were awarded to Mr. J. Walker, Low Fell, Gateshead, and Mr. Arthur Whitton Aiskey, Bedale. Messrs. J. Cocker & Sons had some fine Roses for the time of year, Hollyhocks were shown in remarkably fine condition, Asters, Marigolds, Pansies, Carnations, Picotees, &c., being well represented. Mr. J. Short had a fine collection of hardy flowers, remarkably well-grown samples; indoor flowers being shown by Messrs. McIndoe, E. H. Letts, H. Johnston, and Suffield.

The non-competing exhibits comprised a large and handsome group of Crotons and other plants from Messrs. Little & Billautyne, Carlisle, the Crotons being distinguished by their rich colours, the following varieties Warreul, Sunset, Queen Victoria, Countess, Siuitzinianus, Prince of Wales, Ruberrima Aigburthensis and volutus. Caladium argyrites, Eulalia japonica variegata, with Palms and some fine Dracaenas, were also included in the group. Messrs. Fell & Co., Hexham, had a large group of trees, shrubs, and hardy plants, a fine selection of the best varieties. Mr. W. J. Watson, Newcastle, had a collection of plants and flowers. Messrs. Backhouse and Son, York, had a large collection of Apples. Mr. John Jennings had a group of Ferns, Palms, &c. Messrs. Cocker & Sons, Aberdeen, a collection of Roses. Mr. Forbes of Hawick showed some good Pentstemons; Mr. Alex. Lister, Rothsay, sent some fine Marigolds, Pansies, &c.; Messrs. Dobbie and Co. exhibited a collection of handsome Dahlias, Marigolds, and Pansies; Mr. Robson, Hexham, had a collection of hardy trees, shrubs, and Roses; and Mr. A. G. Brown, gardener to Mrs. Barnes, Whitburn, had a plant of Vallota purpurea with over thirty spikes of flowers, a very handsome specimen.

On the first day of the Show a luncheon was held in the dining room, the Mayor, Sir Benjamin C. Browne, presiding, with Alderman Gray in the vice-chair; there being present the Lord Mayor of York, Sir J. Terry, Canon Lloyd, M.A., the Sheriff of Newcastle, Alderman W. H. Stephenson, and a large number of officials and visitors.

## INDIAN EXPERIENCES.

(Continued from page 161.)

WITH the object of counteracting the deplorable state of things referred to in my last letter, Tea and Chinchona have been planted to a considerable extent both on fresh land and between the lines of the gradually perishing Coffee trees. I have been recently informed, on the best authority, that in this district of the Auchterlony Valley and the neighbouring one of Goodalore, from eight to ten millions of Chinchona trees are being cultivated at the present time, mostly of the Succirubra and Calisya species, and large quantities of bark are now being forwarded to the London markets. The revenue derived from this source will doubtless help to diminish the deficit caused by the Coffee crop failures, but it is highly problematical whether this source of revenue

will long be maintained in the face of rapidly falling prices for all kinds of barks in the markets of the world, owing to over-production in India, Ceylon, and Java by artificial cultivation. The cultivation of Tea would appear to be the planter's sheet anchor for the future, to which he is now turning his attention. It has been amply demonstrated that Tea of excellent quality can be produced in India at similar elevations to the Valley under notice, and that it fetches a fair price in the home markets; and as the Tea shrub has been found to possess a much hardier constitution than that of either Coffee or Chinchona, it follows that its cultivation would be likely to prove of a more permanent nature than either of the last named plants. It is, therefore, to be hoped that the land in the Auchterlony Valley will not be abandoned to the growth of noxious underwood, but that under the operation of intelligent and scientific cultivation, land that was once clothed with the finest Coffee plantations of the south of India, may, ere many years have passed, be occupied with the Tea shrub.

I visited the Auchterlony valley on many occasions during my sojourn in India, and at each visit was more and more charmed with the appearance of the Coffee plantations and the wonderful beauty of the surrounding heights crowned with the everlasting verdure of the forests, from which issued lovely and ample streams of the purest water, which intersected the Coffee estates in their course to the river beyond, and turning many a water wheel on their way. Unlike many Coffee districts, there was ample water here of the purest and best description for all purposes, and yet I never knew the planters turn it to account in the way of irrigation, even in seasons of the greatest drought.

Possessing a delightful climate equally enjoyable to the Englishman and the native of India—a soil, at once of the greatest depth and richest description, capable of producing not only Coffee of the finest description, but also English vegetables of every kind in abundance and of excellent quality, as well as Apples, Peaches, Oranges, Loquats, Limes, Shaddocks, Pine Apples, Pears, and other fruits, and numberless English flowers—this delightful valley seemed to have been set apart by Nature either to be left alone for ever in its pristine beauty of forest and stream, to be the home of the elephant, the bison, the tiger, and the innumerable wild animals and birds that inhabited its forests, or to be changed into a Garden of Eden by the skill and industry of intelligent man, for the permanent benefit of his kind. Instead of that it has run imminent risk of being changed from its primitive grandeur into a pestilential wilderness by the hands of the land speculator hastening to be rich. No better tract of country could be conceived for the settlement of small landholders, both European and native, where by dint of highly cultivating the naturally fertile soil, marvellous crops might have been raised, not only of Coffee, but of many kinds of fruits and vegetables, for the wants of the cultivators and for sale. In no part of the world, I imagine—certainly in no part of Southern India—has the system of speculative husbandry or land jobbing succeeded for any great length of time. If Government, instead of countenancing any such system, had from the first fostered and encouraged the settlement of small land holders, both native and European, in the various Coffee districts of the Presidency of Madras, it would not only have greatly benefited cultivators of the land in general, but it would have been the means, most assuredly, of permanently upholding the land revenue of Government, and instead of the thousands of acres in every district, once covered with Coffee, but now converted into noxious thorny scrub, we should have had well cultivated districts comprised of small but highly cultivated and remunerative holdings, supporting a large population, where, at the present moment, not a soul exists.

There are not wanting indications that the Government of India are becoming alive to the very unsatisfactory state of agriculture in the country, especially with regard to the Coffee, Tea, and Chinchona industries, undertaken to such a large extent by Europeans, and the time may not be far distant when facilities may be afforded settlers of small means to obtain small holdings, which would be almost certain by right cultivation to prove both remunerative to themselves and to the State. The idea that India is but ill adapted to the English constitution is, I think, exploded; at least it is my belief from an experience of seventeen years, that with due care the average Englishman is as likely to live as long and enjoy life quite as much on any of the hill tracts of South India as in any part of his native land.—PLANTER.



## KITCHEN GARDEN.

THE weather has changed at last. It is now cool, and rain has fallen freely. The half-starved crops have benefited greatly by it, and they are now assuming a healthy green colour. It will soon be late in the season to expect quick and luxuriant growth, but the great heat that is in the soil ought to produce much growth during the next month or more. It is this we are looking to for the improvement of our backward crops. Recently sown seeds have been very slow in germinating and making plants of any size; autumn Turnips are very small, but they are sure to attain a useful size during the next two months.



**TRANSPLANTING.**—Where it was so dry as to be useless trying to transplant autumn Cabbage, Lettuce, and such like crops no time should now be lost in getting them in, and if given a good situation and rich soil they will soon make headway. In the ordinary way it would be altogether too late to plant Broccoli, Savoys, and Brussels Sprouts, but during the past few days we have put in large quantities of surplus plants, and if they do not attain any great size they may become large enough to be useful, and if they should remain small during the autumn and winter very probably they may gain size and be valuable in the spring. As a rule there is always too little green stuff in gardens in winter and spring, and hardly ever too much, especially after a severe winter, and garden owners generally would find it an advantage to plant every vacant space at this season. Some of the plants that have been long in the seed beds may be very long in the stem and not appear very promising when put out at first, but a short period of favourable growing weather will soon rectify this. In the fore part of the season many of our plants lost their centres and became blind, but they were soon rooted out and replaced by perfect ones, and the plants in our quarters are now all good, but there may probably still be blind ones in the seed beds, and they should not be transplanted.

**ENDIVE.**—This should now be taken in hand. Plants ready for transplanting should be drawn up and dibbled into a south border, where they will be exposed fully to the sun, and get sheltered from the cold weather, as this batch will be out during November and December, or until destroyed by frost. It is a mistake to plant them too closely, as when they rest against each other they soon decay in late autumn. If planted 15 inches apart each way it is not too much for them. Sow another batch of the Improved Broad-leaved Batavian to produce plants to put in frames or some other sheltered place in October.

**HARVESTING ONIONS.**—Spring sown Onions are below the average in size this season. The sun heat suited them admirably, but the moisture was deficient. They are well matured, however, and if properly harvested will keep well and prove useful. We are not much in favour of large Onions for winter use, or as long keepers; the small or medium sized are the best in this respect, and when we select bulbs for the latest we invariably pick out the smallest. When several kinds of Onions are grown together on one quarter they are not always kept separate when harvested, and very often the late keeping sorts—such as James's Keeping and Bedfordshire Champion, are mixed up with the earlier; in fact all are put together. But this is a mistake, as the latest may be used first, and others which will not keep after February are retained until they are useless, and there is a failure to maintain the supply. If any are mixed let it be with those of a similar character, and always keep the late ones by themselves. In beginning to harvest them they may be drawn up and laid on the ground for a few days. If wet bring them off the soil and spread out on a walk, but when quite dry take them into an airy shed, and keep them there for some weeks. Do not attempt to clean them until quite dry, then the stems and loose peel may easily be brushed off with the hands without injuring the bulb. When once under cover they are safe, and the cleaning may be reserved for a rainy day. The evil resulting from allowing Onions to remain out after this time is that the wet may induce them to grow again, and this will spoil them to a great extent.

**DIGGING POTATOES.**—The Potatoes are giving a good deal of anxiety to their owners. Second growth is expected. This may occur in the case of late sorts which are still green and growing, but it will be the cultivator's own fault if the early and midseason crops are allowed to make second growth, as it may easily be prevented by digging up all crops that are matured, or nearly so. Late sorts must take their chance; to dig them in their present unripe condition would spoil them. We anticipate second growth in them to a certain extent, but all the others should be dug up and stored at once. Dry weather is a great advantage in successful storing. Never attempt to take the tubers up when it is wet, and avoid handling them when the soil is sticking to them. Those who wished to make sure of having the crop in good condition may have lifted them before the rain came, but others may have left them with the hope that they might still improve. They certainly will not do so now, and the sooner they are in the better. This applies to all but the latest crops. So far disease has not proved troublesome; in fact, we have not found an affected tuber in the whole of those we have taken up, and they amount to several tons.

**GLOBE ARTICHOKE.**—These were very good the fore part of the season, but they soon suffered from the drought, and of late they have not furnished any heads for the table. The old ones which were left uncut have bloomed, but it is no advantage to allow this to happen, and as soon as the globes become too old for the kitchen they should be cut off and thrown away. Attend to this at once, and if the stems are cut close to the ground the young growths will soon spring up again, and if protected with some litter during the winter they will fruit early next spring.

**KIDNEY BEANS.**—The runners came well into fruit about the end of July, and they have produced very heavy crops, but they have ceased to flower or fruit and will not produce many more pods for the kitchen. Much later rows will prove very useful, as the rain we are now having will cause them to bear freely. They may not prove quite so good as if the season all through had been in their favour. It will therefore be necessary to see that other means of keeping up a late supply are not neglected. Our latest sowing of Dwarfs will soon be in flower; they will be very useful. Others sown in frames, as directed the other week, are growing now, and they may come in at a time when there is none in the open. There is yet another way of securing them, and that is to

sow a quantity of seed now in pots; grow them in a cool place, and have them ready when the cold weather comes to place in a gentle heat. They will bloom about the end of October and prove valuable during November. Collect material for winter Mushroom beds, plant out more Cabbage plants, sow Prickly Spinach, and check weeds that are now coming up everywhere.

#### FRUIT FORCING.

**PINES.**—Young Pine plants always present at this season, under liberal and proper treatment, a luxuriant appearance; this arises from the beneficial effects of natural means so important in cultivation. Those influences being now on the wane greater care will be necessary in the management to prevent the growth becoming soft, and measures should be taken to consolidate it by a drier atmosphere and artificial heat. Syringing will only be needed occasionally, and it should be done early in the afternoon of bright days. Water must only be given when absolutely necessary, then afford a plentiful supply of weak liquid manure in a tepid state. The bottom heat should be kept steady at 85°, or between 80° and 90°, and pay particular attention to the ventilation, which is important at this period of the year. Plants in a luxuriant condition should have air at 80°, above which ventilate liberally, especially on warm sunny days, and close the house for the day at 80°. The night temperature should be maintained at 65°, allowing 70° to 75° by day artificially.

Fruiting plants should be brought together in a structure suitable for finishing the fruit well. Plants that are intended for starting into fruit early in the year should be selected from those that were started last spring, and be arranged not later than the end of this month, where they can rest for six weeks. Those on which the fruit is swelling should be encouraged with a liberal amount of heat and moisture, keeping the night temperature from 70° to 75°, and that in the daytime from 80 to 90°, closing the house at 85° with sun heat.

**STRAWBERRIES IN POTS.**—The plants are late. Runners were difficult to obtain on account of the drought, and they rooted very tardily through the arid state of the atmosphere. The recent change in the weather has at last set the plants on their way, and all things considered, are making satisfactory progress. In the earliest plants the crowns are becoming plump, sufficiently so, at least, for the detection of plants that will not be available for early forcing, and which should be removed at once, even those about which there is a suspicion of being barren, making good the deficiency from the surplus stock. Worms and weeds are troublesome, also runners. Lime water will expel worms, and the weeds and runners must be promptly removed. The pots should also be wide enough apart to allow of the sun and air having free access to the foliage. The crowns, which are numerous in some kinds, particularly Vicomtesse Hericart de Thury and Sir Charles Napier, should be reduced to the centre or strongest one, not deferring it until they have attained to a considerable size, but as soon as they can be taken hold of with the finger and thumb, and lifted clean out of the socket. This will concentrate all the vigour in the main crown; those will afford strong flower spikes, and then, by selecting the largest and best-formed flowers, a crop of fruit will be insured, large, and creditable to the grower. Any late runners may yet be potted, and with good attention they will be serviceable for late work in 5-inch pots, and may afford very good fruit.

**VINES.**—*Houses of Ripe Grapes.*—Those that contain the thick-skinned varieties will require, whether the Grapes are to be kept on the Vines or in the Grape-room, liberal ventilation with gentle fire heat for the maintenance of a certain circulation of air. With the Grapes ripe gradually reduce the strong laterals as the days decline in length, and keep the foliage healthy by means of a moderate supply of moisture on the walls, paths, and floors sufficiently early in the day to admit of the atmosphere becoming light and buoyant before nightfall. Black Hamburg and other thin-skinned kinds are liable to have the colour taken out of them by hanging under powerful sun. Some netting should be drawn over the lights to prevent it. Hamburgs and Foster's Seedling will bear as much air moisture as the thick-skinned varieties, provided it be not stagnant, and it is very necessary for the benefit of the foliage, but Madresfield Court does not endure air moisture to anything like the same extent as Hamburgs, and must be treated accordingly. It, however, loses colour quite as badly, and must be shielded from the direct rays of the sun. Muscats hanging on Vines with the roots in outside borders will keep a long time, protecting the roots from heavy rains, which are falling bounteously in different parts of the country. A covering of dry Fern, shutters, or tarpaulin answer, but glazed sashes are better, placed in a sloping position for throwing off the wet, as they admit sun heat and retain it for warming the border. If the foliage is not sufficient for the protection of the tender skins of the berries, some light shading will be necessary, particularly where the houses are glazed with large panes of glass. Hexagon netting answers well, and drawn over the ventilators excludes wasps, which have appeared on the scene just when we were congratulating ourselves on their absence. We have hornets and wasps too plentiful.

*Lifting Vines.*—Proceed with this and relaying of the roots of early and midseason Vines as they are cleared of their crops. The sooner it is done the better. Good loam with some brick and lime rubbish and a liberal admixture of charcoal and crushed bones will meet all requirements in respect of compost. See to the drainage, make it satisfactory, and follow on with turf, grass side downwards, or a 3-inch layer of lime rubbish. Keep the roots near to the surface, always bearing in mind that a narrow border well filled with roots is preferable to a large mass of soil at the onset, as the roots can be more easily excited and fed at

the proper time. The Grapes, too, in a border well in hand invariably set and colour better. Always choose dry weather for making the border. Cover it when finished with good stable litter, and keep the interior of the house close and moist until the foliage shows signs of fresh root-action having set in, then ventilate freely and keep the air dry. In all cases, especially cold wet localities, the Vines should have inside as well as outside borders, as the roots can then be lifted and re-laid in either of the borders without injury to the following year's crop.

#### PLANT HOUSES.

*Stephanotis floribunda*.—It is a great mistake to keep this plant too warm, for its growths are more sturdy and more profusely flowered when grown under cooler and more airy conditions than the plant is generally subjected to. Cool, airy treatment after flowering is of the utmost importance to thoroughly harden and ripen the wood before the season for complete rest arrives. The plants that flowered early in the year have had no artificial heat for the last six weeks, and none will be given as long as the temperature can be kept from falling below 50° at night. Abundance of air should be given during the day, and a little left on the structure all night when the weather is mild. The atmospheric conditions of the house should also be much drier than is generally the case. If this plant is infested with mealy bug it should be thoroughly syringed once a week with petroleum and water, one ounce of the former being added to a gallon of the latter. If the oil is well mixed in the manner frequently described, and the plant shaded from strong sun for about two days after syringing, the bug may be thoroughly eradicated. Half measures are next to useless, and syringing with petroleum two or three times a year only reduces the bug and does not prove effectual in clearing the plants entirely of the pest.

*Clerodendron BaFourianum*.—Plants required for forcing into flower early another year should be fully exposed to the sun and kept in a moderately dry atmosphere, where the temperature at night will not fall below 55°. Water should be withheld until the foliage flags, but at first this system of bringing growth to a standstill must not be persisted in too severely, or the plant will ripen its foliage prematurely. It is, however, necessary to induce the plant to rest, for it will continue to grow at this season of the year in a low temperature if kept moist at the roots. Plants that flowered later must be encouraged as much as possible to make and mature their wood before the approach of winter. Those required for late flowering another year should be kept growing as long as possible before they are induced to rest, or they will naturally start into growth and flower too early.

*Clerodendron fallax*.—Plants intended for autumn and winter flowering should be placed at once into 5, 6, and 10-inch pots according to size. If the most forward of these plants, now in 7-inch pots, show signs of flowering, the point of the central shoot must be removed and strong lateral growth encouraged. Keep the plants close for a time after potting them; they will soon commence rooting freely in the new soil, and in due time large heads of brilliant scarlet flowers will be produced.

*Bougainvillea glabra*.—Plants intended for early flowering should occupy a cool airy structure to ripen them. They are better grown under such conditions than in heated houses, as their wood will become hard and ripe, which is the secret of flowering them well another year. Those in active growth should have every encouragement to complete it as early as possible. If the plants are crowded, remove weak growths completely, so that strong luxuriant ones will have every chance of ripening properly—an impossibility if the plants are crowded with useless wood.

*Allamandas*.—Those for early flowering should be induced to complete their growth by placing them in a lower and drier atmosphere. Water must also be partially withheld until they show signs of flagging; sufficient, however, should be given to keep the wood fresh and plump. If liberally watered and grown under warm conditions, the plants would continue to grow and flower until the end of the year. Plants started later into growth may with advantage be retained for this purpose. The pots or border may be top-dressed with rich material to keep the roots active, and liquid manure may be given in a weak state every time they need water.

#### THE FLOWER GARDEN AND PLEASURE GROUND.

*Early Frosts*.—Already we have had warning that frosts may at any time disfigure the more tender bedding plants. Dahlias in some low-lying districts were touched by frosts as early as the third week in August, but it is to be hoped that they will escape further injury for some time to come, for as yet they have given but few flowers. It is almost impossible to protect bedding plants generally, but the carpet beds may easily be preserved in good colour for some time longer. Whenever the nights are cold or frost threatens, canvas, or blinds of some description, may be stretched over the beds, stakes and material being removed in the morning. This will ward off all but very severe frosts, those adopting the plan being well repaid for the little extra trouble taken. Iresines, Alternantheras, Ageratums, Coleuses, and Heliotropes are among the first to be injured by frost or much cold rain, and if stock plants are not already secured some ought to be potted from the open ground at once. We usually have a considerable number of surplus plants in the mixed or kitchen garden borders, this enabling us to lift early if need be without disfiguring the principal beds. Failing these a few may yet be got out of the beds without leaving unsightly gaps. It is not advisable to lift with large balls of soil, a lighter fresh compost suiting the plants much better. They will recover from the

cheek of lifting more quickly in gentle heat, and shaded from bright sunshine.

*Late Propagating*.—Zonal Pelar oniums of all sorts have made but little progress this season, the excessively hot weather favouring flowering rather than strong growth. As a consequence few cuttings have been taken off. Many will attempt late propagation, and the cuttings being well matured a good strike may result. Those we put in late are first made, then allowed to dry for a few hours. If dibbled into boxes they are most liable to damp off either now or later on, and we prefer to use well drained 6-inch pots for the strong growers or green-leaved sorts, and 3½-inch or rather larger for the more delicate variegated varieties. They are at once put under glass, the former into dry pits and frames, and the variegated sorts on shelves in empty vineries, Peach, and greenhouses. No water is given at first, in fact they are kept somewhat dry till they are wanted to grow strongly early in the spring. Under the most careful treatment 15 to 25 per cent. will be lost, but the plan of staking late cuttings is preferable to depending largely on lifted old plants for affording cuttings next spring. We would also make a late attempt, if necessary, to strike soft young growth of Verbenas, Lobelias, Ageratums, Iresines, Coleuses, Alternantheras, Alyssum, Marguerites, and Mesembryanthemums. These should be dibbled in rather thickly in 5-inch pots, and placed in a close frame over a gentle bottom heat. They must be watered in, shaded from bright sunshine, and given a little air only when damp is likely to spread and injure them. They may be wintered in the pots they have rooted in, and in the spring will yield a quantity of good cuttings. The Mesembryanthemums and Sempervivum arboreum strike best on a dry sunny shelf in heat, and must be very carefully watered, or the cuttings will damp off wholesale. Cuttings of Calceolarias and Violas are late and scarce. Fortunately the plants are now growing vigorously, and cuttings may be put in as late as the first week in October with every prospect of a successful strike.

*Tuberous Begonias*.—Many who have recently commenced using this beautiful and rain-defying class of plants in their summer arrangements are somewhat at a loss what to do with them. Just now they are flowering grandly, and may safely be left in the ground till frosts badly damage the tops, when the bulbs may be lifted, much of the soil cleared from the roots, and be then packed closely in boxes of fairly moist soil. Kept in a cool room, house, or shed, and protected from severe frost and drip, they will remain plump and sound till started into growth late in the spring. Begonias in full bloom may be readily potted from the open ground, and they will remain in good condition in a greenhouse or conservatory for several weeks. It is unwise to attempt to lift them with a very large ball of soil about the roots, in fact very little is needed, and the pots used for them may vary from 6 inches to 8 inches in size. Now that such excellent strains of tuberous Begonias can be bought cheaply it is scarcely advisable to retain the poor older sort. Those that are most effective in pots are also much the best in beds. At any rate it is advisable to mark the best, and keep these in separate boxes. Begonia weltoniensis and B. Carrieri are both very effective in beds, and lift safely. The former will flower in a cool house for several weeks longer, while Carrieri is a very charming white variety, and continuous flowering in gentle heat. Newly struck tuberous Begonias will form small bulbs before the top growth decays, and these should be stored as advised in the case of the larger tubers.



#### HINTS TO BEGINNERS.

##### HIVES.

WHATEVER sort of hive the beginner fixes upon different from what I have recommended, he should be careful, if double-cased, to have the sides of the hive rising considerably above the top of the frames, and the roof to go outside the hive, telescopic fashion, for throwing off water and preventing it being drawn in by capillary attraction, as is the case commonly with checked roofs. But the two sides above the frames must not be fixed; there must be a joint on a level with the top of the frames, and this joint, as well as all others, must be well bevelled underneath, and have the rain drip above. This portion ought to be fixed with brass screws. This convenience will suggest itself to the merest tyro when manipulating with crates or supers. It is very convenient for the bees, if either the back or front of the hive is thoroughly closed, if it be at all chilly, or shaded from the sun's rays. If that is not done, many bees during winter are apt to be lost when they fall or are drifted behind. The hive open causes a great draught, some sites being worse than others.

##### WATER.

This should be provided for bees whenever that is not obtainable at an easy and safe distance from the apiary. A good watertrough may be easily made from inch wood, say 2 feet long by 9 inches broad, thoroughly pointed before putting in the water. Strike off

a few inches at one end by a division to which a lid should be added. The other portion ought to have a very thin float nailed to cleats to prevent warping, and support it from below with pieces of cork to prevent sinking, as no matter how carefully floats are made, without this precaution they will sink when saturated. Put some sulphate of iron in the small recess, then fill with water and keep it so. The sulphate of iron is, I believe, more destructive to small organisms than is carbolic acid, and may be the means of warding off foul brood.

#### ROBBER BEES.

Robbing is the bane of bee-keeping to many a beginner, and its prevention is the greatest desideratum to successful bee-keeping. For that reason I would advise that no hive be opened without taking it indoors, or under some structure where stronger bees have not access. During the present season bees and queens entering hives other than their own have been the cause of much mischief, which to a novice would be quite bewildering; for example, two prime swarms after they had been lived some five or six days, and were working well in their supers, suddenly disappeared from them, during finer weather, too. A few days explained the mystery; young queens were being brought forward, and there was quite a paucity of bees. The finding of part swarms and fertilised queens fully supported my surmise. Sometimes an absconding swarm will be allowed to enter another hive without the slightest resistance, but as often not. Numerous cases of the former sort have come under my observation this year. Often while one swarm is on the wing, another from some adjoining apiary will join with it, often causing an exodus of bees from it the next day, either partial or wholly.

Some time since I related an account of a queen entering a queenless hive, and was deposed the day after, when a young queen was added. This is almost invariably the case; seldom is it that the laying one is spared. A second case of the same nature came under my notice a short time since. Two queens were being reared in a tumbler for a queenless hive. I was watching for their exit. On the same day they were hatched I found two expelled outside. One had a peculiar appearance, which I dissected, when I found her a fertilised queen. The day before I found a small stray swarm, which I put into a box, but the bees deserted their queen, flying into other hives, and managed to kill a number of queens in stock hives, as well as one in my observatory, and the queen had taken refuge in the hive she was expelled from. I have experienced numerous cases of a similar nature, but the following is perhaps as interesting as any. On the 24th July, at five o'clock P.M., a young Carniolian was on the wing, and for twenty minutes I watched her attempting to enter the hive, but never flying far from it. The bees seemed as determined to keep her out as she was to get in, and would probably have succeeded had I not given a larger entrance. For days after I observed her flying, but apparently never had mated, nor flew far for that purpose. As the weather was suitable for mating at the time, she continued flying up till about the 8th August, when on that day I heard her crying, and when I went to the hive found her attacked by about half a dozen bees. I released her, but in half an hour after found her balled and maimed on the landing board; but whether it was a pure regicidal attack, or done by stranger bees, I am not sure, as one dead bee lay alongside the queen, and immediately after other two were killed.

#### DRONES.

These must be regarded as necessary in the hive, and drone traps should not be called into requisition. All that is necessary is to prevent over-much drone comb being built. Drones are generally described as if they were of a uniform character, and all having the same note in their hum. It is not so. There are as differences in drones as in queens, from the noble and stately looking fellow to the dwarf and almost imperfect insect. Now it is a fact, the more handsome-looking the drone is, the more attractive is his hum. Am I right, therefore, in saying that this is a law in Nature, that the queen from the sound may select the most perfect drone with ease, to the future prosperity of the hive? Are drones of use inside a hive or are they not? The following account of what I found in a few hives lately will answer the question. A hive weighty with honey, having many drones, but a paucity of bees, had brood on five combs in all stages. Two of these combs were almost totally occupied by drones, and their position was changed daily. Not one of these drones will be killed until young bees are hatched. The second hive I examined had little honey, few bees, and a moderate number of drones. The queen was newly fertilised, and the bees were already slaughtering the drones. The third had a paucity of bees, drones, and meat. They also were killing the drones. The fourth hive was not examined internally, because I observed from the motion of the bees the queen was still a virgin,

and likely to be flying soon. The drones of this hive were on the wing, and the bees were tugging at them, which to the inexperienced would be taken as an onset upon them; but it is common when the queen is unfertilised, the bees get impatient, and hurry out the drones in the manner indicated. The interesting part of it was, that as one bee tugged the drone half over the landing board, another flew directly to him and fed him, and then out flew the queen, coming back in less than twenty minutes with signs of fertilisation, and the following day was laying. Another queen, however, that was fertilised more than a week since has not yet laid an egg. The hive is well stacked and stored in everything, and no drones are being killed. I fear I have already said more about drones than some of your readers will care about, so will draw rein for the present, and off to the moors with a cargo of supers, more pleasant than a dog and gun to—A LANARKSHIRE BEE-KEEPER.

#### NORTH OF SCOTLAND APIARIAN SOCIETY.

THE annual show of bees, hives, honey, and comestibles was held in St. Katharine's Hall, Shiprow, Aberdeen, on August 30th and 31st. The Show was a most interesting one, and bids fair to outstrip some others, so far as it aims directly to better the bee-keeper by encouraging the manufacture of comestibles and liqueurs from honey of a quality and flavour that sugar could not produce, as well as promoting the whole art of bee husbandry, also in establishing some direct means whereby honey may be disposed of by the members of the Society.

There were twenty-three classes, with about 150 entries. Most of the exhibits were of a superior order, particularly those in the comestible and liquor classes. There was, however, an entire absence of mead proper, but I have no doubt will not occur next season. Of all the comestibles I have witnessed at other shows none approached to those at Aberdeen. The crystallised fruits, confections, cakes, puddings, creams, jellies, biscuits, scones, liqueurs, &c., were excellent in flavour and appearance—suitable, in fact, for the table of the Queen, and we were proud to hear that a first prize Stewarton super purchased at this Show was to be placed on the Royal table. If the competitors in the classes for comestibles—particularly the winners—would publish the recipes for the various articles exhibited they would be benefactors to all.

Mr. Gibb of the Marischall College, exhibited many interesting views of the anatomy of queen and bees and the pollen of different flowers by means of upwards of a dozen powerful microscopes, which were greatly admired by many of the visitors. There was a class for rosettes or badges to be worn by stewards. Some very pretty designs were shown. One novelty in the shape of a frame hive, having frames and dummy made from white satin, was greatly admired. The first prize display of honey exhibited by Mr. Leslie Tait of Foveran, Aberdeenshire, consisting of 4 cwt., comprised excellent samples of sections and drift honey, the arrangement being attractive and pleasing. The classes for honey and honeycomb were of superior quality. The collections of hives and bee furniture were extensive, neat and workmanlike, while the prices were extremely low. The sections of the exhibitor mentioned were in many respects superior to the American ones, his comb foundation was superior to any other at the Exhibition.

Mr. Cockburn's collection was of a superior order and contained many novelties, and was deservedly awarded the first prize. Mr. George Brown, New Pittsligo, had also an exceptionally fine exhibit, cheap and well made, but the articles were less numerous than in the other exhibits. Messrs. Cardno and Darling, 11, Bridge Street, Aberdeen, exhibited a very large number of cheap appliances, and were awarded a special prize for the exhibit, as well as several awards for novelties in appliances. The Judges were Mr. James Cowie, Wester Haremess, Monquhitter, and Mr. Wm. Thomson, Blantyre, who awarded the prizes to the satisfaction of all, even to the unsuccessful competitors, who, on the night previous to the judging, had gone over the exhibits and fixed their opinion. We think a mistake is made in not having ladies as adjudicators, especially of comestibles.

The opening ceremony was performed at noon by Lord Provost Henderson in the presence of a large and select audience, among whom we observed Mr. P. Esslemont, M.P.; James Mathews, Esq., of Springhill; Baillie Berry, Shoremaster Sutherland, Major Crombie, Rev. Mr. Innes, Skene; Mr. Walter Merchant; Councillors Findlay, Callie, Byres, and Mr. Smith, seedsman. Rev. Mr. Innes, President of the Society, introduced Lord Provost Henderson, who said it was with very great pleasure that he responded to the request of the Committee to open the Exhibition of the Society, whose members now reached upwards of a hundred, and who were desirous that such a Society would benefit the crofters and others by turning their attention to profitable bee husbandry, enabling them to add to their income, thereby eeking out a better livelihood than if they allowed the flowers to "waste their sweetness on the desert air." He then pointed out the advantages to be gained by bee-keeping, summarising the workings of the bee and the internal economy of the hive, and said in support of bee-keeping that a young man had gone from the office in London of which he (the Lord Provost) was a partner two years ago, and was now making a fortune in New South Wales, and urged upon the people of this country to devote more attention to bee-keeping, so that we may be less dependent upon the substance called honey we receive from abroad. He also stated that Mr. Innes, who had at one time been tutor to his children, was now engaged initiating them in the art of bee husbandry. He then gave a racy description of the



superstitions concerning bees, and thereafter pronounced the Show opened. Rev. Mr. Innes made a suitable reply. The Members of Committee and others, along with the Judges, dined together, when many topics of bee husbandry were discussed, as also the benefits likely to arise from a society on the lines of the British Bee-keepers' Union, and the hope was expressed that the days were passed of shows that benefited the dealer only.

The following are the awards:—

For the neatest and best display of honey, extracted and in comb—1st prize Highland Society's silver medal—Leslie Tait, Foveran. The best super of honey, not being a sectional super—1, John Forrest, Gardens, Haddo House; 2, W. Young, Inchmarlo; 3, John Tough, Mirebird, Crathes. For the best super of honey in straw only—1, J. M. Beveridge, Schoolhouse, Torphins; 2, W. Young; 3, W. Rae, Inchmarlo. The best ten 2-lb. sections of comb honey—1, W. Munro, Crathes Station; 2, A. Cadenhead, Stocket; 3, John Tough. The best ten 1-lb. sections of comb honey—1, W. Young; 2 and 3, W. Munro, Crathes. The best ten 2-lb. jars of extracted or run honey—1, A. Cadenhead; 2, George Green, Cluny; 3, A. Cadenhead. The best ten 1-lb. jars of extracted or run honey—1, W. Munro; 2 and commended, A. Cadenhead; 3, George Green. The best sample of run or extracted heather honey, in glass jar, not less than 10 lbs. weight—1, William Young; 2, William Rae; 3, R. McGregor, Inchmarlo. The best sample of run or extracted clover honey, in glass jar, not less than 10 lbs. weight—1, W. Munro; 2, John Tough; 3, A. Cadenhead; commended, George Green. The best mead or beer, made with honey, not less than two quarts, with recipe attached—1, Miss Rennie, 13, Richmond Terrace, Aberdeen; 2 and 3, Mrs. Michie, Foveran; 3 and commended, R. McGregor. The best honey flavoured cake with recipe attached—1, Mrs. Tait, Foveran; 2 and 3, George Jack, Backmill, Turriff; highly commended, J. M. Beveridge; commended, Mrs. Michie. The best collections of honey flavoured articles, as food and liqueurs—1, George Jack; 2, Mrs. Tait; 3, Mrs. Innes, Free Church Manse, Skene. The best collection of hives and bee furniture, no two articles alike—1, A. Cockburn, Cairnie, by Keith; 2, Leslie Tait; 3, George Brown, New Pitligo. The best observatory hive, stocked with bees and their queen—1, Francis Stewart, 2, R. McGregor; 3, W. Rae. The best sample of wax, not less than 2 lbs. in each exhibit—1, R. McGregor; 2 and commended, John Tough; 3 and commended, William Munro. Collections of the best honey and pollen-producing flowers, with descriptive list attached—1, Miss Mary Innes, Skene; 2, Frank Innes, do.; 3, Thomas Porteous Black. The best essay on the various methods of bee-keeping as practised in the North of Scotland in the past and at the present time—1, George Jack, Turriff; 2, A. Cockburn. The greatest variety of living wild bees and their nests—1, 2, and 3, A. McFarlane, Hector House, Old Aberdeen. The best super of any kind—1, William Young; 2, R. McGregor; 3, John Tough. The best display of honey in sections—John Tough. Special ladies' prizes, for best display of honey extracted or in comb, taken from hives under their own management—Catherine Drummond, Great Western Road, Aberdeen. For best and neatest rosette or badge to be worn by stewards in attendance at show—1, Mrs. Tait, Foveran; 2, Mrs. Michie; 3, George Jaek.

#### TRADE CATALOGUES RECEIVED.

Charles Turner, Royal Nurseries, Slough.—*Catalogue of Bulbs*, 1887.

Oakshott & Millard, Reading.—*Special List of Bulbs*.

Benjamin Soddy, 243, Walworth Road, London.—*Catalogue of Dutch Bulbs*.

Dobie & Mason, 66, Deansgate, Manchester.—*Catalogue of Hyacinths, Tulips, Crocuses, &c.*

Barr & Son, 12, King Street, Covent Garden.—*Descriptive Catalogue of Bulbs and Plants*.

James Carter & Co., 237, High Holborn, London.—*Illustrated Catalogue of Bulbs*.



\* \* \* All correspondence should be directed either to "THE EDITOR" or to "THE PUBLISHER." Letters addressed to Dr. Hogg or members of the staff often remain unopened unavoidably. We request that no one will write privately to any of our correspondents, as doing so subjects them to unjustifiable trouble and expense.

Correspondents should not mix up on the same sheet questions relating to Gardening and those on Bee subjects, and should never send more than two or three questions at once. All articles intended for insertion should be written on one side of the paper only. We cannot reply to questions through the post, and we do not undertake to return rejected communications.

**LATE INQUIRIES.**—It is necessary to again remind correspondents that letters arriving on WEDNESDAY MORNING cannot be answered in the "next issue," which is then far advanced for press.

**Earwigs** (*M. A. Burnham*).—Please quote the date and page of the Journal to which your note refers, and your letter shall have further attention.

**Manure for Mushrooms** (*W. F. M.*).—Wednesday's letters can only be answered in the briefest manner, if at all. Do what you propose. Do not let the manure remain so long unturned, and it will be less noxious. A small quantity is best prepared under shelter, and spread out somewhat thinly is not offensive.

**Apple Leaves Blotched** (*H. Piggot*).—The spots or blotches on the Apple leaves are caused by the larvæ of the Pear tree blister moth (*Tinea Clerckella*), which in its perfect state is a minute moth, appearing in May and June, depositing its eggs upon the foliage, and the larvæ immediately they are hatched penetrate beneath the cuticle, and by feeding upon the parenchyma cause numerous brown blisters. When fully grown, or in September, it lets itself to the ground, and spins a cocoon on a leaf, changes into a chrysalis, in which state it remains until the following season. All dead leaves should be removed in autumn, digging the ground near the trees, and the trees washed with soapsuds occasionally from the middle of May to the middle of June.

**Blindness in Cabbage** (*Idem*).—There is no proof that it is caused by an insect, and certainly it is not the result of drought. A correspondent who has great experience in kitchen gardening attributes "blindness" of the plants to imperfect fertilisation of the flower, resulting in an imperfect formation of the seed, and consequently defective plants. We have seen one packet of seed yield many "blind" plants, another few or none.

**Vine Leaves Withering** (*D. B. D.*).—It is a little singular you did not state at first what you state now. We were not far wrong in our surmise that there was too much moisture in the house. We suspected there were plants in it, but you could scarcely expect us to guess of the existence of a Pear tree shading one end where the unsatisfactory Vine is planted. The shade, with moisture from the Ferns, is sufficient to account for the condition of the foliage. The leaf sent from the other end of the house is highly satisfactory, and shows you did not use too much of Thomson's manure, and that it did not do harm but good.

**Grapes and Flowers** (*G. H.*).—We received some Grapes in a box, but no letter referring to them. The fruit was smashed with shaking about, and the juice converted some paper in the box almost into pulp; if that was your letter not a line of writing was visible, nor were the numbers attached to the flowers.

**Cucumbers** (*H. J. M.*).—It is quite certain a Cucumber could not grow 3 inches in a day in a "cold frame," and if either the plant or the fruit extended that length the frame would be a warm one. You do not say whether you refer to the fruit or to the plant. The "Cottage Gardener's Dictionary" is an excellent work for amateurs who desire sound knowledge on the cultivation of plants, fruit, and vegetables. Its price is 7s. 6d.; 8s. post free, and can be had from this office.

**Abnormal Grape Production** (*T. W.*).—The small bunch of Grapes you have sent with a portion of the old wood attached showing its issue direct from the old rod of the Vine, and not from a growing lateral, is unusual, though we have seen a similar case. On closely examining the stalk we find half an inch from the base a contraction, you would possibly have noticed it also. That thicker half-inch is simply all that remains of a lateral that was pushing from the rod. The growth was arrested just where a small bunch of Grapes was forming, and these swelled and ripened, but no leaves developed. The bunch, then, is borne on a lateral half an inch long, so closely resembling the stalk of the fruit that its true character can only be perceived through a powerful magnifying glass. That is the explanation of the phenomenon of a bunch of Grapes pushing from the old rod of your Vine.

**Various** (*A Young Gardener*).—Syringe the Peach and Nectarine trees so soon as the fruit is gathered with petroleum, a wineglassful to a four-gallon watering-potful of water, in which 6 ozs. soft soap and an ounce of soda have been dissolved. Keep the mixture constantly agitated whilst applying it to the trees, wetting them thoroughly in every part. Repeat in the course of a few days. Give the Chrysanthemums liquid manure and allow them plenty of room. The Primulas should be repotted without delay, and in doing so do not disturb the roots more than can be helped. If in pots already sufficiently large surface dress and feed with liquid manure. Kelp is a good manure for Cauliflowers and most vegetable crops. A half-peck may be given per rod. Apply it as a surface dressing. Stocks are not usually good for winter flowering; but East Lothians or Intermediate are excellent for spring flowering, but it is too late for sowing now. Keep the Fuchsia safe from frost through the winter. Prune in February, repot when it begins to grow, and shift into larger pots as necessary. There is no better method of storing Celery than keeping it well earthed and protected. Leaf soil and cocoa refuse thoroughly reduced form a good substitute for peat, using a sixth of silver sand, and potting firmly.

**Grapes not Colouring** (*Doctor*).—The Grapes having commenced colouring, and being now at a "standstill," will not, we fear, make any further effort in that direction. The only thing we can advise is not to reduce the foliage, but if anything allow it to extend, and instead of increasing the heat merely keep a gentle warmth in the pipes so as to insure a temperature of 70° to 75° by day artificially and 60° to 65° at night, admitting air constantly sufficient to insure a circulation, and with sun admit air very freely. We anticipate the Grapes are ripe, and in that case they will not colour further. Want of colour is chiefly a consequence of overcropping, or insufficient supplies of nutriment for the demands of the fruit.

**Exhibition Plants** (*J. S.*).—From the information contained in your letter it would be difficult to give a list of plants that would prove suitable to you; but if you will write to us again, stating whether you want them to be in good condition for any particular time of year, we shall be pleased to assist you. For instance, we might name flowering plants that would be right for showing during July and August that would be useless if required six

weeks or two months earlier. We might include Azaleas and some early flowering Heaths, that would be indispensable if required for early shows, but useless for summer or autumn shows. You will no doubt readily perceive the necessity for tending to us the information we need to assist us in the selection of flowering plants that would be best for your requirements.

**Destroying Thrips on Azaleas and Ferns (H. C.).**—Tobacco is the best remedy for aphides and also for thrips. Where fumigation cannot be practised we advise the tobacco juice of the manufacturer to be diluted with six times the quantity of water at 90° to 100°, strained, and the plants dipped or syringed so as to wet the Azalea leaves and fronds of the Ferns on the under side, and when dry syringe with clean water. If necessary repeat this application.

**Gloire de Dijon Rose (H. C.).**—By removing the flower buds now the plant will ripen the growths quicker and be correspondingly invigorated, but it is hardly likely to cause the plant to flower again in the winter, though it would materially assist it in flowering in the spring.

**Evergreens for Covering Banks (F. P., Exeter).**—The best covering for a bank that we have seen and planted were *Hypericum olympicum* and *H. calycinum*, which form a dense evergreen mass, and have bright golden flowers in June onwards.

**Lime for Rose Beds (T. Tatham).**—Lime is a capital dressing for Rose beds, particularly old beds, which have been highly manured, and have the surface close and full of humus. A dressing may be given in October or early November at the rate of a bushel per rod, and freshly slaked, pointing it in, or not deeper than 6 inches. For new beds it is also a necessary addition on most soils, but it should not be given in the fresh state along with manure, but previously, and to the extent before named. If the soil has been freshly manured, or it is necessary to add manure for enrichment, then use old mortar rubbish from an old building freed of the woody matter that usually accompanies such material, and to the extent of a sixth for heavy soil, and smaller proportion as the soil is inclined to be light, mixing it well with the top 18 inches.

**Garden Infested with Millipedes (W. R.).**—The species enclosed is a small millipede (*Julus pulchellus*). Its presence in such numbers suggests that either the land needs draining or is rich in vegetable matter, and needs a corrective in the form of lime. This may be given now or as soon as cleared of the crops, or distributed amongst those that are permanent, such as Strawberries, in the freshly slaked state, at the rate of a bushel per square rod, choosing dry weather, and merely pointing it in with a fork. Lime will sink far enough without burying it deeply in the first instance. The lime will convert the humus into nitrate of lime, hasten the decay of the vegetable substances, and prove deterrent, if not destructive, to the millipedes. Gas lime will either kill or drive them away. It cannot, however, be applied safely to land under crop. Ground cleared of its crops should be dressed with it, using a peck per rod, distributed evenly on the surface, and allowing it to remain a few weeks before being pointed in.

**Heating Tomato Houses (A. B.).**—Bottom heat is a great aid in early forcing, and is very desirable for Tomatoes, as it ensures a sturdy habit through the roots being in advance of the top growth. We are certain that it will return you a good per-centage on the outlay, the plants affording fruit sooner, which brings better returns from the salesmen. Two 4-inch flows and one return on each side of a house 20 feet wide are ample for Tomatoes. Muriate of potash is an excellent manure for Tomatoes, not applying more at any time than a couple of ounces per square yard. It may be obtained of any agricultural manure dealer, or horticultural sundriesman. The side pits could not well be utilised for forcing Asparagus between the Tomato plants, as the latter will need to be 18 inches apart, and trained as single cordons. There are of course other modes of training, but we like the one-stem system, and have plants so trained with Tomatoes hanging like "ropes" of Onions. For early work cuttings should be inserted without delay, when struck potted off singly and grown so as to have strong plants for putting out by the new year.

**Thinning Seedling Asparagus (H. C.).**—You will not do much good now by thinning out the seedlings unless it is intended to allow the plants to remain where sown, then the plants should be thinned to a foot distance apart in the rows and without a moment's delay, as it will help those left to ripen the growths better and form finer buds. If the plants are very thick thinning will be difficult, and we should advise waiting until spring, and then lift the whole of the plants, making a selection of the best, and planting in rows a yard apart and the plants 12 inches asunder in the rows, or if large heads are wanted 18 inches. The early part of April is the best time to transplant Asparagus, or when the plants have pushed growth a few inches long.

**Names of Fruits.**—The names and addresses of senders of fruit to be named must in all cases be enclosed with the specimens, whether letters referring to the fruit are sent by post or not. The names are not necessarily required for publication, initials sufficing for that. Only six specimens can be named at once, and beyond that number cannot be preserved. (R. L.).—1, Ecklinville; 3, Doyenné du Comice; 4, Flemish Beauty; 6, Dunmore. The others are too immature to enable us to distinguish them. (W. Godwin).—The smaller Apple said to be a seedling is Red Astrachan. The larger one we do not know.

**Names of Plants.**—We only undertake to name species of plants, not varieties that have originated from seed and termed florists' flowers. Flowering specimens are necessary of flowering plants, and Fern fronds should bear spores. Specimens should arrive in a fresh state in firm boxes. Slightly damp moss or soft green leaves form the best packing, dry cotton wool the worst. Not more than six specimens can be named at once. (T. W.).—*Stapelia bufonia* (good var.), *Vanda Roxburghi*, *Acropera Loddigesii*. (W. W.).—The Orchids are, A, *Promeneae citrina*, and B, *Maxillaria picta*. We should be glad to see the drawing you mention. (*Lady King*).—*Gnaphalium lanatum*.

COVENT GARDEN MARKET.—SEPTEMBER 7TH.  
MARKET completely girtted with drop fruit. Prices all round much lower.

FRUIT.

	s. d.	s. d.		s. d.	s. d.
Apples, ½ sieve .. ..	1 6	to 3 6	Oranges, per 100 .. ..	6 0	to 12 0
Nova Scotia and			Peaches, dozen .. ..	2 0	6 0
Canada barrel	0 0	0 0	Pears, dozen .. ..	1 0	1 6
Cherries, ½ sieve .. ..	0 0	0 0	Pine Apples, English,		
Cobs, 100 lbs. .. ..	0 0	50 0	per lb. .. ..	1 6	0 0
Figs, dozen .. ..	0 9	1 0	Plums, ½ sieve .. ..	1 6	2 6
Grapes, per lb. .. ..	0 6	2 6	St. Michael Pines, each	3 0	5 0
Lemons, case .. ..	10 0	15 0	Strawberries, per lb. ..	0 0	0 0
Melon, each .. ..	0 6	1 0			

VEGETABLES.

	s. d.	s. d.		s. d.	s. d.
Articboker, dozen .. ..	1 0	to 2 0	Lettuce, dozen .. ..	0 9	to 0 0
Asparagus, bundle .. ..	0 0	0 0	Musbrooms, punnet .. ..	0 6	1 0
Beans, Kidney, per lb. ..	0 3	0 0	Mustard and Cress, punt.	0 2	0 6
Beet, Red, dozen .. ..	1 0	2 0	Ouions, bunch. .. ..	0 3	0 6
Broccoli, bundle .. ..	0 0	0 0	Parsley, dozen bunches	3 0	3 0
Brussels Sprouts, ½ sieve	0 0	0 0	Parsnips, dozen .. ..	1 0	0 0
Cabbage, dozen .. ..	1 6	0 0	Potatoes, per cwt. .. ..	4 0	5 0
Capsicums, per 100 .. ..	1 6	2 0	„ Kidney, per cwt.	4 0	0 0
Carrots, bunch .. ..	0 4	0 0	Rhubarb, bundle .. ..	0 2	0 0
Cauliflowers, dozen .. ..	3 0	4 0	Salsafy, bundle .. ..	1 0	1 6
Celery, bundle .. ..	1 6	2 0	Scorzenera, bundle .. ..	1 6	0 0
Coleworts, doz. bunches	2 0	4 0	Seakale, basket .. ..	0 0	0 0
Cucumbers, each .. ..	0 4	0 6	Sballots, per lb. .. ..	0 3	0 0
Endive, dozen .. ..	1 0	2 0	Spinach, bushel .. ..	3 0	4 0
Herbs, bunch .. ..	0 2	0 0	Tomatoes, per lb. .. ..	0 4	0 6
Leeks, bunch .. ..	0 3	0 4	Turnips, bunch .. ..	0 4	0 6

PLANTS IN POTS.

	s. d.	s. d.		s. d.	s. d.
Aralia Sieboldi, dozen ..	6 0	to 12 0	Fuchsias, dozen .. ..	3 0	to 9 0
Arbor vitae (golden) dozen	6 0	9 0	Geranium (Ivy), dozen ..	3 0	6 0
„ (common), dozen ..	0 0	0 0	„ Tricolor, dozen .. ..	3 0	6 0
Asters, dozen pots .. ..	3 0	6 0	Gladolus .. .. ..	4 0	6 0
Azalea, dozen .. ..	0 0	0 0	Hydrangea, dozen .. ..	9 0	12 0
Begonias, dozen .. ..	4 0	9 0	Lilies Valley, dozen .. ..	0 0	0 0
Capsicums, dozen .. ..	6 0	9 0	Lillium lancifolium, doz.	12 0	18 0
Cineraria, dozen .. ..	0 0	0 0	„ longiflorum, doz.	0 0	0 0
Creeping Jenny, dozen ..	0 0	0 0	Lobelia, dozen .. ..	0 0	0 0
Dracena terminalis, doz.	30 0	60 0	Marguerite Daisy, dozen	6 0	12 0
„ viridis, dozen .. ..	12 0	24 0	Mignonette, dozen .. ..	3 0	6 0
Erica, various, dozen ..	9 0	18 0	Musk, dozen .. ..	2 0	4 0
Euonymus, in var., dozen	6 0	18 0	Myrtles, dozen .. ..	6 0	12 0
Evergreens, in var., dozen	6 0	24 0	Palms, in var., each ..	2 6	21 0
Ferns, in variety, dozen	4 0	18 0	Pelargoniums, dozen ..	6 0	12 0
Ficus elastica, each ..	1 6	7 0	„ scarlet, doz.	3 0	9 0
Foliage Plants, var., each	2 0	10 0	Spiraea, dozen .. ..	0 0	0 0

CUT FLOWERS.

	s. d.	s. d.		s. d.	s. d.
Abutilons, 12 bunches ..	2 0	to 4 0	Lilies, White, 12 bunches	0 0	to 0 0
Anemones, 12 bunches ..	0 0	0 0	„ Orange, 12 bunches	0 0	0 0
Arum Lilies, 12 blooms ..	3 0	6 0	Lily of Valley, 12 sprays	0 0	0 0
Asters, 12 bunches .. ..	2 0	6 0	„ 12 bunches	0 0	0 0
„ French, bunch .. ..	1 6	2 0	Marguerites, 12 bunches	2 0	6 0
Azalea, 12 sprays .. ..	0 0	0 0	Mignonette, 12 bunches	1 0	3 0
Bluebells, 12 bunches ..	0 0	0 0	Myosotis, 12 bunches ..	1 6	3 0
Bouvardias, bunch .. ..	0 6	1 0	Narciss, 12 bunches ..	0 0	0 0
Camellias, blooms .. ..	0 0	0 0	„ White, English, bch.	0 0	0 0
Carnations, 12 blooms ..	1 0	2 0	Pansies, 12 bunches ..	0 0	0 0
„ 12 bunches .. ..	4 0	6 0	Peas, Sweet, 12 bunches ..	1 6	3 0
Cornflower, 12 bunches ..	1 6	3 0	Pelargoniums, 12 trusses	0 9	1 0
Dahlia, 12 bunches .. ..	2 0	4 0	„ scarlet, 12 trusses	0 3	0 6
Daisies, 12 bunches .. ..	2 0	4 0	Pinks, White, 12 bunches	0 0	0 0
Encbaris, dozen .. ..	2 0	4 0	„ various, 12 bunch	2 0	4 0
Gardenias, 12 blooms ..	2 0	5 0	Paeony, 12 bunches .. ..	0 0	0 0
Gladolus, 12 sprays .. ..	1 0	1 6	Poinsettia, 12 blooms ..	0 0	0 0
Hyacinths, Roman, 12			Primula (single), bunch ..	0 0	0 0
sprays .. ..	0 0	0 0	„ (double), bunch ..	0 9	1 0
Iris, 12 bunches .. ..	0 0	0 0	Polyantbus, 12 bunches ..	0 0	0 0
Lapageria, white, 12			Ranunculus, 12 bunches	0 0	0 0
blooms .. ..	1 6	8 0	Roses, 12 bunches .. ..	2 0	6 0
Lapageria, coloured, 12			„ (indoor), dozen .. ..	0 9	1 0
blooms .. ..	1 0	1 6	„ Tea, dozen .. ..	1 6	3 0
Lilac (white), French,			„ red dozen .. ..	0 0	0 0
bunch .. ..	0 0	0 0	„ de Moix, 12 bunches	0 0	0 0
Lillium longiflorum, 12			Stephanotis, 12 sprays ..	2 6	4 0
blooms .. ..	2 0	3 0	Tropaeolum, 12 bunches	0 0	0 0
Lillium lancifolium, 12			Tuberoses, 12 blooms ..	0 6	1 0
blooms .. ..	0 6	1 0	Tulips, dozen blooms ..	0 0	0 0



KEEPING A COW.

A CORRESPONDENT has written to us for advice about the selection, purchase, and management of a cow, and gladly do we reply to his inquiry in this prominent manner, for there are, without doubt, many readers of the Journal who, like "H. S. E.," would like to keep a cow of their own and so ensure a supply of pure milk for their household, and be able to indulge in the luxury of plenty

of cream, good butter, white soups, custards, trifles, and other articles of diet into which dairy produce enters largely.

A disappointment is, however, in store for our friends at the outset, for we are bound to tell them that a constant supply of milk the year round is not to be had from one cow. For at least two months of the time before and after calving the milk supply will cease entirely, and there will be a steady falling off in quantity for some time previously; and, therefore, to have a constant and full supply of milk two cows at least are necessary. Into this we need not enter further, and it will answer our purpose fully if we now proceed to consider the selection and management of a cow.

Our correspondent mentions a Jersey or a half-bred Jersey as being the best breed for butter, and we agree, but question the wisdom of going out of the way to obtain a single cow of a particular breed, because there are always cows of local breeds that are good enough for all practical purposes. For example, "H. S. E." resides in East Anglia, and he cannot do better than purchase a polled Suffolk cow, for most of them are deep milkers, the milk is rich and the butter excellent. A neighbour of ours has a fine herd of polled cows kept solely for butter making, the quantity of butter made annually at the farm being upwards of two tons. It is true enough that certain local breeds like the Sussex cows are not good dairy cows, but there are plenty of good cross-bred cows to be had in Sussex.

If, possible, select a young cow soon after it has had its second calf, for it will then be at its best, and a safe opinion may be had of its good and bad qualities. Older cows may, of course, be purchased provided sound judgment is brought to bear upon the matter. Do not be tempted to buy a cow sent to market for sale with its calf, however tempting its appearance may be. Depend upon it the cow is sold for some fault, such as poverty of milk either in quantity or quality, a vicious temper, a tendency to barrenness, or difficult parturition. A beginner should either purchase a well-known cow at the Michaelmas auction sale of an outgoing farm tenant, or get a person upon whose judgment he can rely to procure one for him: the price will be from £12 to £20, very useful cows being now sold for prices very little beyond the lower sum.

If the cow is purchased at Michaelmas there would probably be enough grass upon the pasture for the next month, but the cow should not be exposed to the heavy downpour of rain which we so frequently have in October; a little stall feeding with hay and some Oat straw in the yard must therefore be taken into our calculation of ways and means. Stall feeding from the end of October till the end of March—a period of five months—is a certainty, and there must be due provision of food for the whole of that time. A cow requires about 70 lbs. of food daily, or say about 1 ton a month, so that at least 5 tons per cow should be stored for the winter months, and with such a late spring as we had this year there should be a surplus for April. Of the 5 tons one at least should consist of meadow hay and the remainder of roots, Oat or Barley straw, and bran. A mixed diet is altogether best, and to 14 lbs. of hay and 7 lbs. of bran we may add sliced Carrots or Mangolds, with some chopped straw, and if a supply of Cabbages can be had a moderate quantity tends materially to the maintenance of a full flow of milk. Turnips should never be used uncooked for milch cows, as they impart a rank bitter flavour to the butter that is very unpalatable. If cooked and the

water poured off they may be used with chaff, and cows are very fond of them so prepared.

Pure water, fresh air, and cleanliness are indispensable. The cow shed should be snug and warm, but there should be thorough ventilation both day and night. The floor should be of asphalt or cement, and if litter is used for bedding it should be removed every morning and the floor swept clean. We hold that cleanliness in the cow house is as important as it is in the dairy, and we have no doubt that the filthy state in which cows are so often seen tends to spoil both milk and butter. It will be understood that we never turn out cows on pasture in winter; they have exercise in the yard upon fine days, but are kept in the shed at night and from exposure to cold and wet.

(To be continued.)

#### WORK ON THE HOME FARM.

Enough rain has fallen to keep stubble Turnips growing, and we now hope to have sufficient for the ewes and lambs next spring, but the roots at best can now only be small. Mangolds are growing freely, and on some farms the crop will be a heavy one; on others it will be inferior. Some flockmasters have been compelled to pull Mangolds for the half-starved sheep, as there was nothing for them upon the meadows, and we have seen Mangolds pulled and thrown upon the stubbles for the sheep. We have made no purchases of old sheep for folding this autumn, for the scarcity of green food and of roots convinced us that we could not do so profitably. Yet there was some temptation to buy sheep, for much of the second growth of Red Clover was worthless, both for seed and stover. We turned what growth there was to account by letting it for grazing at about £1 per acre, upon condition that the sheep had a given quantity of oilcake daily, the flockmaster sending a shepherd in charge of the sheep with hurdles and troughs, and they were to be kept in each fold for twenty-four hours. Under these conditions we have had some 1200 sheep upon two of our off farms, which have manured the land and left it quite ready for ploughing for Wheat, and we have received a handsome sum of money for rent into the bargain. We mention this matter, by the way, as an illustration of our teaching that a farmer should not invariably act by line and rule, but rather adapt himself to circumstances, and try and turn to account each outcome of peculiar seasons.

The tups are now with the ewes for service in order to have lambs early in January. The ewes are strong selected animals in high condition, which, at this season of the year, is maintained solely by grazing upon sound pastures, the tups only having corn when they are kept from the ewes upon alternate days. We use lamb tups of the Hampshire Down breed with half-bred Suffolk ewes. From this cross we obtain fine lambs, which come to hand for market by the first week in June, or in about eighteen weeks from the birth, and we believe them to be more hardy and to come to maturity earlier than the pure bred Suffolks. We may mention that every faulty ewe was withdrawn from the flock immediately after the lambs were weaned. Among such are included barrens, crones, or over-age ewes, and any having bud udders or any other faults rendering them unsuitable for rearing lambs.

#### METEOROLOGICAL OBSERVATIONS.

CAMDEN SQUARE, LONDON.

Lat. 51° 32' 40" N.; Long. 0° 8' 0" W.; Altitude, 111 feet.

DATE.	9 A.M.				IN THE DAY.				Rain	
	Barometer at sea level.	Hygrometer.		Direction of Wind.	Temp. of soil at 1 foot.	Shade Temperature.		Radiation Temperature.		
		Dry.	Wet.			Max.	Min.	In sun.		On grass
1887. Aug.—Sep.	Inches.	deg.	deg.		deg.	deg.	deg.	deg.	deg.	In.
Sunday .....	29.756	66.7	65.0	E.	62.6	75.7	60.3	110.9	57.6	—
Monday .....	29.676	64.2	59.2	S.	63.1	73.5	57.7	118.2	52.8	0.24
Tuesday .....	29.739	65.3	59.9	S.W.	62.7	72.1	59.0	112.7	56.4	0.43
Wednesday .....	29.473	62.6	57.3	W.	62.2	70.4	54.6	117.2	53.7	0.09
Thursday .....	29.723	61.6	58.4	S.	61.2	65.2	54.3	84.6	51.1	0.23
Friday .....	29.583	56.9	51.0	S.W.	60.5	63.7	56.1	101.2	51.8	0.06
Saturday .....	29.812	60.1	54.7	W.	59.5	69.2	52.4	112.8	47.9	0.08
	29.612	62.5	57.9		61.7	70.0	56.6	108.2	53.0	1.58

#### REMARKS

28th.—A shower in early morning; then fair, though frequently threatening, throughout.  
29th.—Heavy rain in the morning, with thunder at 9 A.M. and at 10 A.M.; fine afternoon; rain again at night.  
30th.—Fine morning; wet afternoon and evening; gale and heavy rain at night.  
31st.—Stormy, with squalls of rain early and in the morning, bright between whiles; one peal of thunder at 2.45 P.M., followed by a sharp squall of rain and hail, then bright sunshine; another sharp shower about an hour later; fair evening; much wind throughout.  
1st.—Dull, with heavy showers at 11.30 A.M. and 1 P.M.; wet evening; strong S.W. gale at night.  
2nd.—Gale continued, but with diminished force; dull and showery till after 3 P.M., then fine.  
3rd.—Fine bright morning, clouding over towards noon; fair afternoon; wet night.  
A wet and windy week. Mean temperature about 3° above the average, and almost exactly the same as that of the preceding week. This week, however, the mean maximum temperature approximated to the average, and was about 6° lower than that of the preceding week, while the mean minimum temperature was about as much above both the average and that of the preceding week.—G. J. SIMONS.





## COMING EVENTS

15	TH	Brighton Show.
16	F	Manchester Show (two days).
17	S	
18	SUN	15TH SUNDAY AFTER TRINITY.
19	M	
20	Tu	
21	W	

### SHOWING AND JUDGING.

**L**XHIBITIONS of garden produce have, without doubt, contributed powerfully to superiority of culture; and if it had not been for such shows British gardening would not have attained its generally high standard of to-day. There would have been expert cultivators in the absence of these shows, just as there were before their existence, because there are men who require no external stimulus to urge them on in accomplishing the self-imposed task of excelling all former efforts. That, however, is not the habit or the nature of all. It may be safely said the majority need spurring on, so to say, to place them in the front ranks of workers in practical horticulture; and many professional gardeners and non-skilled amateurs have been fired with a zeal to excel by the splendid examples of others that have been displayed at public exhibitions. Flower shows have, moreover, been the means of inducing thousands of persons to indulge in the pleasant occupation of gardening, and to become growers of flowers, fruits, or vegetables. They have seen the achievements of others and been compelled to become cultivators in turn, and have eventually become formidable competitors. Thus has the taste for gardening spread and a great industry been created.

In order to increase the interest, not in shows alone, but in the delightful art of which they are the exponents, opportunities should be afforded for the greatest possible number of cultivators to place before the public the best examples of cultural skill that can be produced. And this should honestly represent their own work. As a rule the schedules of shows are comprehensive and judiciously framed, but there is very little doubt that classes have been introduced by persons of a nature which the proposers of them felt they could compete in successfully. There is, perhaps, no great harm in that if keen competition ensues and the products staged are grown by the exhibitor, and at the same time are meritorious. Persons who are animated by selfish motives in the framing of schedules are sure to be "taken in" sooner or later, and that matter, of which complaints are not unheard, usually rights itself.

A subject of much greater importance is the growing tendency to offer exciting prizes for which it is known only a few can compete; because in that case it practically amounts to distributing large sums of the money of a society amongst those few, for the classes are so framed as to deter the great body of cultivators from entering, and they are deterred. Nor are these sensational prizes won with the "best of everything." They are won because of the skill or ingenuity of competitors in placing on the tables the requisite number of the

articles stipulated for, and the greater this number is the more inferior must many of the individual products be. That plan is neither encouraging to gardeners as a body nor resultant of the highest examples of cultural skill.

The produce staged in a class of twelve dishes of fruit and vegetables is better and the competition keener than in a class of twice that number of dishes, and it is the same in respect to plants; the greater the number of specimens named, the fewer the competitors and the weaker some of the plants must be. When experience shows that large amounts offered for a great number of individual exhibits in a class brings out good and genuine competition the plan is justified by results; but when, on the other hand, there is little or no competition in these big classes for the great prizes, as is not unfrequently the case, the question arises as to whether it would not be better to allocate the money differently—spread it over a wider field in restricting the stipulations within reasonable and practical bounds, thus opening the classes more widely, and giving more than three prizes in each. It is quite common to see meritorious collections left out in the cold where the competition is great, while large sums are awarded for produce relatively inferior in the larger classes simply because the competition is small. It is true the judges at most shows are empowered to withhold prizes when the exhibits are not considered of such merit as to deserve them, also to grant extra prizes to meritorious exhibits; but as a rule they simply follow the schedule, because by withholding prizes or granting an inferior prize they incur the risk of sharp criticism. There is, however, no good reason why they should either fear that or object to it, especially since in the great majority of cases their decisions are right. Nor are they encouraged to give extra prizes, for in the first place the funds at disposal often do not allow of this; and, secondly, when a start is made in making extra awards it is not easy to know where to stop. If more than three prizes are provided, as they are at the shows of florists' flowers, these prizes are adjudged as a duty, and it is almost certain that if the number of prizes were increased in some fruit classes the competition would increase accordingly, and a greater and a better aggregate show be the gratifying result. It is also conceivable that this might be accomplished with less expenditure than when the lion's share of the sum total is spent on a sensational class or two from which, by its very nature, a large number of good cultivators are excluded.

In the report of the Crystal Palace Show last week, Mr. H. W. Ward is credited with the first prize (£8) for a collection of twenty bunches of Grapes in ten varieties, while in the next class of two bunches each of five varieties the whole of the three prizes only amount to £1 more; yet if there were only three competitors there would be thirty bunches which, because of the limit as to number and variety, may be confidently regarded as much superior to the twenty in the big class. There may be a doubt as to the actual value of the Longford Grapes, one version of the report (official) placing them first, the judges' card third; but that does not affect the fact of a good competition and thirty bunches bringing a reward of £9 to three prize-takers, while £8 goes into the pocket of one exhibitor of twenty bunches, in a class where there is "no competition."

Again, in the report of the Newcastle Show, a great class is noted, in which there were only three competitions, absorbing £50 of the prize money; while in the two classes for eight and four dishes there were no less

than sixteen competitors, the fruit on the whole being far more meritorious than in the "Jubilee" sensation, in which common hardy fruits, including Gooseberries and Currants, figured conspicuously, and from which Pine Apples were excluded. Yet the amount offered in the classes in which there was such good competition—and, as, the report indicates, splendid fruit—bore no comparison to that awarded in the class in which there were just three competitors, in which anything that could be had appears to have been scraped together for making up the requisite number of dishes. It is recorded that in the eight-dish class five prizes were awarded, and if there had been only the orthodox three it is fair to assume that some exhibitors would have had nothing for as good fruit probably as in the class over which £50 was distributed.

It would seem to be regarded almost as a crime for exhibitors to question the manner in which prize money is distributed over schedules, or the awards made by judges at shows. They have an indisputable right to do both, and, in the former case especially, good reason for their objection to the existing order of things of the nature of the examples referred to. As to judges at shows, they are public functionaries engaged in a public duty, and the best of them not immaculate. They are open to criticism, and they ought to be. If it were not for public criticism of the decisions of honest, able and experienced men on the judicial bench, many a wrong verdict would have had to be endured that has been righted, and other errors of judgment have probably been averted because of the very criticism that some, with the best of motives, condemn. Cases are well known where the verdicts of judges at horticultural shows have been reversed by the very judges who made them, when something they had overlooked had been brought to their notice just before the shows were open to the public—for it is most difficult for alterations to be made afterwards. When judges are in threes two of them may agree, yet the one who disagrees may be right. This has been so more than once, and afterwards admitted. Prizes have been awarded that have been almost unanimously condemned, and the judges who awarded them would gladly have revised them if some points had been brought to their notice before the shows were open to the public. Persons who have had experience in the inner working of shows know that the facts are as stated, and yet the judges of flowers, fruit, and vegetables above all other judges, must be above criticism! Why? Competent judges who are conscious of having made no mistake can afford to be criticised, and it is only those who have a lurking doubt as to whether they have erred or not who are afraid of it; and efforts made to prevent the public discussion of a public matter are very apt to engender a feeling that there is reason for discontent, while actually no valid reason may exist when the matter is fully investigated. "Protests" by disappointed exhibitors are estimated accordingly, but the dissent of competent men who are not disappointed is entitled to respect. There are always as good judges in a great show as those who happen to be chosen to make the awards; and in nineteen cases out of twenty the opinion of the unprejudiced majority of these expert cultivators is in harmony with the awards; but that is no reason why the twentieth case, if wrong, should not be pointed out.

It can never be forgotten that exhibitors who protest against awards made to their own produce place themselves in a delicate position, for if they are as fair and impartial as the judges are they would equally protest against being adjudged a prize in excess of the merits of their produce as they would when they feel its value

underestimated. Take as an example the last public protest. Supposing the judges had placed the first-prize card on the Grapes exhibited by Mr. Ward, it is morally certain that there would have been much dissent; and in that case, being as impartial as the judges and as desirous of doing justice to all—to the promoters of the show and exhibitors—he would have protested against being awarded the first prize. It is by that test that complaints are judged; therefore unless a complainant is on very firm ground indeed he will strengthen the position of the judges he condemns, and thus it is that these officials, being cultivators of standing, adjudicators of experience, and men of high character, have not the slightest dread of public criticism, for if they have they are scarcely fit to occupy the important public position that makes them so prominent as that to which they are or were elected.—*EXPERIENTIA DOCET.*

### GOOD MUSHROOM CULTURE.

SINCE "Mushrooms for the Million" appeared very few, if any, articles have appeared in the Journal on the cultivation of the Mushroom until the one appeared under the above heading at page 158. Many gardeners still fail in their cultivation, and however valuable outside beds are for early and late supplies, I may say that for a constant supply through the winter, and especially through a winter like the past, it does not do to trust to outside beds alone. Last winter we were fairly successful in their production, and the following notes may be acceptable to some readers, especially as they differ in some instances from the article at page 158.

I fully endorse "E. N. R.'s" estimate of the manure to be used, but it takes us about three weeks to collect sufficient droppings for a bed, so it is laid out in an open shed about a foot in depth, and turned occasionally until a sufficient quantity is collected, when it is thrown into a heap and turned every day, or every other day as required, until the manure is in a proper condition—not too wet or too dry. When ready it is taken to the Mushroom house and formed into a bed, placing it in layers and beating firmly as the work proceeds. In the article in question 80° is given as the highest point the temperature of the bed should rise to. Our beds generally rise to 100° or 110°, and sometimes more. If it rises above 100° we bore holes over the bed so as to prevent it overheating. When the temperature falls to 85° the holes are closed and the bricks of spawn laid on the top of the bed and turned every morning. The spawn soon commences running, and by the time the temperature is down to 80° the bed is spawned, and the soil which has previously been placed in the house to warm is put on and the whole beaten down solidly. When the temperature of the bed falls to 70° mats, about a couple in thickness, are laid on the bed, and allowed to remain there until the young Mushrooms appear, when the mats are removed, and the bed receives a gentle watering with soft water at a temperature of 80°. The mats are again laid over the bed, but are not now placed directly on it, but are supported 3 inches off it with strips of wood. The temperature of the house is kept at from 55° to 60°, and is damped every morning. We have gathered Mushrooms in three weeks from the time the spawn was inserted, but a month is about the rule.

Laying the spawn on the bed brings it on a week in advance, and there need be no fear of inserting bad spawn. It is not an original idea, but it is not practised nearly so much as it ought to be. I also think that Mushroom beds are allowed to cool too much before inserting the spawn: 65° is far too low, 75° to 80° is nearer the mark. The mats, besides keeping up the temperature of the bed, keep the soil in a uniform state as regards moisture. When the surface is not covered the soil is apt to get too dry, and so take a larger quantity of water than is good for the bed. Over-dryness of the dung before being made into a bed is often the cause of many failures; it had much better be a little too wet than too dry.—A. YOUNG.

### FLOWERS IN EAST LOTHIAN.

ONE great advantage we who live north of the Tweed have over those who are located in the southern counties of England is the comparative coolness of the nights, no matter how hot and drying the day may be. Thus it occurred that plants which were languishing in the daytime under the intensity of the sun's heat and for lack of moisture, were in the morning hours upright and seemingly little the worse for the previous day's ordeal. Phloxes were the only flowers well cultivated which refused to be comforted.

They drooped at night, and were equally flaccid in the morning. Taking them altogether they have been failures. Hardy flowers as a class do not stand the heat, and those who have nothing better to depend upon in a season like this will have had but a sorry display. Bulbous species have been the most satisfactory. *Alstroemerias*, some *Lilies*, *Gladiolus* species, *Tigridias*, *Hyacinthus candicans*, &c., have never been better. The hybrid *Gladiolus* have also been exceptionally fine. Last year only six small spikes could be gathered the second week in September. This year they have been abundant all through August, several plants running up to 6 and 7 feet in height, and as a matter of course the spikes were proportionately fine. These, however, have been watered occasionally. Roses were good whilst they lasted, but were remarkably soon over; something like the *Strawberries* in that respect. *Dahlias*, on the other hand, have grown with great rapidity and flowered most profusely. *Hollyhocks* have not been so good. *Asters* plainly appreciate plenty of sunshine, being much better than usual. *Sunflowers* also have enjoyed the drought. *Pentstemons*, even a few that were watered, are not so good as usual. *Antirrhinums* also poorer than usual. *Pinks* and *Carnations*, though not so large, have done remarkably well, very few losses having occurred, an experience quite novel here. We lifted the layers a fortnight ago, and shall expect a strong bloom next year. We are growing some hundreds of early *Chrysanthemums* on the mixed borders, and these have come out of the ordeal splendidly. The plants flagged best seem none the worse, and are now quite bright and effective. Single *Zinnias* have thriven amazingly—most lovely flowers these—and so have *Salpiglossis*, also beautiful, though in some seasons neither so well.

Of the more strictly bedding plants nothing could be better than the common *Paris Daisy*. The plants are dwarf and one sheet of white. *Alternantheras* have also been specially high coloured and finer than usual. *Zonal Pelargoniums* have, as a matter of course, been masses of flowers, *Henry Jacoby* being in particular very rich. The old *Christine*, planted with a yellow *Violas* intermixed, is most soft and pleasing. Some of the variegated kinds have not been quite so effective as usual, the drought being seemingly inimical to fine foliage. *Violas* have done wonderfully well, plenty of water and no seed pods allowed to form being the chief means of keeping these fine. *Calceolarias* are not quite so good as usual. *Lobelias*, with exception of *Wave of Blue*, not so good. *Ageratums*, *Tropæolums*, and double *Ivy-leaf Pelargoniums* all very good, *Begonias* poor. The one great drawback to the effectiveness of the flower garden has been the paucity of green. The grass in the parks has been quite browned, and portions of the lawn even worse, so that the great foil to high colouring has been this season wanting in some degree. However, recent showers are changing all that, and with a fairly good autumn we shall have a lengthened season of flowers. Cuttings are slightly smaller this year, and we have been fully a fortnight later in securing them; but by striking them under glass we shall make them larger before winter, and hope to lose nothing of consequence through the very great heat.—B.

#### NOTES ON THE CULTIVATION OF ASPARAGUS.

SINCE taking the charge of these gardens I have been fortunate in producing some extra fine *Asparagus*. A few notes on the cultivation of that esteemed vegetable as practised here may prove of service to beginners, especially to those whose employers are particularly fond of it and like large heads. As soon as sufficiently ripe, we cut off all the matured stems and hoe the surface of the beds as deep as we can without injury to the roots, clearing off all the weeds and refuse. As winter approaches the beds are well mulched with decayed cow manure, say from 3 to 4 inches in depth, which should be short, as if not it prevents the heads pushing through the surface, often causing them to turn again into the soil. We then dig up the alleys between the beds with a fork, for if done with the spade the roots from the outer rows are very liable to be cut, thereby causing damage to the plants. About the middle of March we stretch a line by the edge of the beds, straighten them with a spade after the surface has been levelled; if not in this condition we draw some of the manure into the hollows, and lightly cover the beds with soil from the alleys. Care should be taken not to allow the beds to rise over 6 inches above the ground level. This may be prevented in autumn by drawing some of the top soil into the alleys before covering with manure. Beds that are raised considerably above the level are very liable to suffer by drought, especially during a hot dry season such as we have experienced this year, unless the sides of the alleys are mulched. It may be necessary to raise the beds higher in low localities where the soil is heavy, wet, and cold. We then give the beds a good dressing of common garden salt, covering them with it. This we consider a great help

to the production of good large heads, keeping the beds all the season free from weeds—an important matter, and one that is too often the cause of failure in growing good *Asparagus*. When the beds are covered with weeds all the growing season the young heads draw up weakly, and the beds are robbed of their fertility to a large extent. Our soil is of a light sandy nature, and this I believe to be what *Asparagus* likes, when liberally supplied with manure and well attended in other respects.

When I first took charge of these gardens the practice was to grow the *Asparagus* rows on the flat, which I considered was not the best mode, and therefore resolved to make them into beds. This has proved to be a better method, for the results have been satisfactory, and my employer informs me that the *Asparagus* this season is not only the finest, but the best flavoured he has ever had. The beds should be made about 3 feet 6 inches wide, planting three rows 1 foot apart, and the same distance, or a little more, between each plant in the rows, and about 4 inches deep. The outside rows are therefore 9 inches from the edge of the bed. At each end we drive in a stout stake as a future guide, leaving the alleys 1 foot or 15 inches wide. We never water good established beds, and our plants have stood the drought of this season without showing the least signs of distress; in fact, I believe the "grass" to be stronger and better than it was last year.

We planted some one-year-old plants at the end of April, 1886 (which were procured by Mr. Dick during his stay in France) on an old bed from which the plants were lifted for early forcing. The ground was well trenched, with a large quantity of decayed cow manure added to it. We then dug the trenches the same distance and depth as recommended, every care being taken to spread out the roots. After covering, they were well watered, and kept moist during the growing season. They made very good progress, and this season the growth has been surprising, some very fine heads being produced. To next season we look forward hopefully, for we anticipate as fine, if not finer, heads than we have been able to cut this year. Great care should be taken in cutting the heads. I prefer an ordinary pruning knife well sharpened. The soil should be moved lightly from the heads, and then cut in a slanting direction downwards until the head is loose. We cut close until about the middle of June, then only the best heads, discontinuing it as soon as we can procure Peas in sufficient quantity to take the place of *Asparagus*.

I trust these few notes (my first) may prove beneficial to young gardeners who may have taken the charge of beds in a state of decline, or are not in that vigorous condition that may be desired, as well as to those who may anticipate preparing ground to replace beds that are practically worn out.—P. T. D.

[We trust these "first" useful notes will not be the last we shall have from our able correspondent.]



#### DENDROCHILUM FILIFORME.

At the recent flower show held at Ewell, Mr. D. Whiteman, gardener to A. W. Gadesden, Esq., Ewell Castle, was awarded first prize for a beautiful collection of plants in a class for the best group arranged for effect. In the centre was a fine specimen of *Dendrochilum filiforme*, with exactly 100 drooping spikes of yellow flowers, each measuring about 18 inches from the top of the pseudo-bulb. The plant is growing in a 24-size pot, and the material used is peat and sphagnum mixed together, and plenty of drainage. It has been grown in the warm house, but for a month previous to being exhibited it was in bloom in the conservatory. Few Orchid blooms have lasted fresh so long a time during the hot months of July and August.

#### CALANTHES.

These are also well grown by Mr. Whiteman. He has about a hundred plants growing in 32-sized pots in a stove close to the glass, but shaded from the bright sunshine. The leaves are a deep green colour, and many of the bulbs of *C. Veitchi* exceed a foot in length; others suspended from the roof of the East Indian house are even larger, and there will no doubt be a grand display of blooms at a time when most valued. The compost consists of peat, fibrous loam, cow dung, crocks, charcoal, and a sprinkling of coarse silver sand.



## MISCELLANEOUS ORCHIDS.

Many of the good but old-fashioned Orchids are well represented. *Cœlogyne cristata*, *C. ocellata*, *C. corrugata*, and *C. speciosa*, *Cypripedium insigne*, *C. hirsutissimum*, are in quantity, and the plants large. The useful *Dendrobium nobile* and its variety *cœrulescens*, *D. densiflorum*, *D. fimbriatum*, and *D. thyrsoflorum*, are all well grown, with *Oncidium Harrisoni*, *O. tigrinum*, and *Zygopetalum Mackayi*. Pleiones, like *Calanthes*, are well cultivated, and are in various stages; the earliest are just showing flower spikes. There are not many Orchids in bloom, but among others are *Odontoglossum bictoniense*, with twenty flowers on a spike, *Oncidium Lanceanum*, *Miltonia spectabilis*. *Cypripedium Pearcei* (*caricinum*) in a large pan is very singular, having narrow grass-like leaves, and the spikes rising well above the foliage, producing six flowers on each of a pale green colour. *C. longifolium* has been blooming a long time, *Sobralia macrantha*, and *Zygopetalum maxillare*. The gardens are very interesting, and much might be written of the well-managed occupants in each department.—G. W. C.

## MELON NOTES.

It is not general for Melons to be grown without being provided with heat, either from hot-water pipes or fermenting material, as generally the disease to which Melons are subject is more quickly engendered in a low temperature than when a good warmth is maintained. The present season has been one that would naturally favour the culture of Melons on this principle, but few are prepared to venture on so uncertain a speculation. In the gardens of Draycot House, Chippenham, there has been an excellent though not extensive crop of this indispensable fruit, which has been grown without the aid of either fermenting manure or hot water, the plants having been most vigorous, clean, and healthy. The house in which this crop was grown is a small lean-to, 20 feet by 7 feet, and from this small roof space nearly thirty fruits have been cut, averaging 3½ lbs. each, all of one variety, Sutton's Imperial Green-flesh. This sort, Mr. Gibson, the able gardener, has formed a high opinion of. The fruits become beautifully netted, are perfect in shape, and is very deep in the flesh, there being no cavity between the seeds and flesh, as is common with many varieties.

Rich soil Mr. Gibson is careful to avoid for these crops, as from this cause alone canker is very apt to occur when grown on the restricted methods. Medium clay, or the second spit from a pasture, is what is employed at Draycot, this being stacked some few months before required for use, to cause it to become mellow, nothing whatever being added to this beyond a sprinkling of lime until after the fruits are set, when a small quantity of fish guano is applied. It is surprising what vigorous plants may be grown in such a soil. Several leaves measured exceeded 14 inches in diameter, and proportionately stout; the plants retaining their full vigour until the fruits were cut, no drying off being practised. Air was not given until after mid-day, but a slight shade was given to prevent burning. A little air was admitted after the sun had lost its influence for about two hours, this plan being adopted to allow of the leaves and house becoming dry before nightfall, as the paths, walls, and bed were kept constantly moist during the early part of the day. Altogether this instance of Melon culture may be termed a success, the method of procedure practised being quite economical and satisfactory in principle.—W.

## HANGING BASKETS FOR THE WARM FERNERY.

If hanging baskets are useful accessories to the ornamentation of the cool fernery, they are just as much needed in the warm house devoted to the cultivation of Ferns and other foliage plants; but in this we have less difficulty to contend with, as there is a far larger quantity of plants from which a varied selection can be made; and on account of the great diversity found among stove Ferns, both as regards colour and form, a much greater variation may be obtained through the planting of these hanging baskets in various sizes. Exceedingly pretty little miniature ones can be made exclusively with the *Adiantums Edgeworthi*, *dolabriforme*, and *caudatum*, all three evergreen East Indian species of small and rampant growth. Their being prolific at the apex of the fronds is a great recommendation for the purpose which we have in view, as these species frequently show three, and even four generations of plants hanging from the original or mother fronds. The general appearance of *A. Edgeworthi* or *ciliatum*, as it is sometimes called, is as distinct as it is pleasing, on account of the lovely soft green tint of its pubescent foliage, as also because of the elegant way in which the pinnae, pink in their young stage, are divided. *A. caudatum* is easily distinguished from the above by the greyish

and dull colour of its fronds, and also by the peculiar shape of its pinnae, which are much more cuneiform; while in *A. dolabriforme* we have a plant entirely distinct from the other two; and, although it appears as only a variety of the lovely *A. lunulatum*, it is much to be valued on account of its evergreen character, which does not belong to the species. This *A. dolabriforme* was sent out only a few years ago by Mr. B. S. Williams (to whom we are indebted for the illustration), with the idea that it would prove a plant of great value for basket culture, and the anticipation has been fully realised, for it forms a dense yet elegant mass of a particularly bright green foliage, and has been the means of making some of the prettiest small baskets that we ever had the good fortune to see.

*A. lunulatum*, although naturally deciduous, is well worthy of cultivation for basket purposes; and, although it is an old species, I well remember the sensation which a few years ago a huge basket of it created at one of the quinquennial Belgian exhibitions. The plant in that memorable occasion had been grown in London by its exhibitors; and, while in February there were no signs of life, by the time of the exhibition, in June or July, the basket was in such perfection that it riveted the admiration of all beholders. This distinct and handsome species, of slender pendulous habit, has foliage of a peculiar shape, its alternate pinnae being lunulate and of a particularly bright green colour, which forms a pleasing contrast with the shining black colour of the rachis and stalks, which are very conspicuous. Its foliage remains in good condition until about the middle of October, when it dies down naturally; and if the plant is properly treated during the winter and not allowed to get dust dry it usually starts into growth about the middle of February, or at the latest the beginning of March, and rapidly forms a most interesting mass of verdure. Very pretty small baskets are also made with *Asplenium elegantulum*, an evergreen dwarf species from the Fiji Islands, which, like the above-named *Adiantums*, is prolific at the apex and of a dark shining green colour; and the uncommon New Holland species called *flabelifolium*, which on account of its extremely slender growing nature, is particularly well adapted for that purpose. Its fronds, generally from 12 to 15 inches long, are formed of two parallel rows of small and curiously fan-shaped pinnae, of a bright dark green colour, and thoroughly distinct aspect; the apex of its fronds is also prolific, and it is easily propagated.

The Ferns which may with advantage be used for the formation of baskets of a larger or medium size are much more numerous than those adapted for small ones, and for that purpose almost any Ferns of a drooping habit can be utilised; but the genus which supplies us with the greatest number is undoubtedly that of *Davallia*. The majority of these plants are provided with creeping rhizomes, which render them most valuable for such a use, as in course of time they entirely clothe the outer surface of the baskets in which they are planted and make handsome objects. Their foliage, elegant and finely cut generally, looks particularly handsome when seen from below, and being very tenacious remains a long time on the plants. In *Davallia bullata* we have one of the most attractive of the genus, with fronds about 10 inches long, nearly triangular in shape, and of a rich dark shining green colour, produced on creeping rhizomes, which are covered with minute scales of a bright reddish hue, accounting for the popular appellation of the Squirrel's Foot Fern. *Davallia elegans* and its variety *dissecta* from Java are also included among the most useful Ferns for basket purposes; the fronds of both species and variety are more finely cut than those of *D. bullata*, and produced on rhizomes of a much lighter colour. They average from 15 inches to 24 inches in length, and are quite 8 inches in width at their base. In the same way also is *D. solida*, whose fronds, however, are more plumose and of a brighter green colour, smooth and shining. Although several more, such as *D. fijiensis*, *ornata*, *Mooreana*, and the beautiful and new *tenuifolia Veitchiana*, of which an illustration was given in the Journal of August 11th, page 111, and others may be grown in hanging baskets, the above named are the most useful among the *Davallias* grown for baskets of medium size.

For the same purpose most of the Gold and Silver Ferns may also be used with great effect, the more so since the farinaceous powder, which is peculiar to them, and which is their principal ornament, is seen to a greater advantage in that position than when the same plants are grown in pots. There is nothing more effective than a good plant well established in a suspended basket of the West Indies species *Gymnogramma tartarea*, with massive fronds fully 2 feet long and quite 8 inches wide, dark green above, but of a beautiful and very even whiteness underneath. *G. pulchella*, from Venezuela, is equally interesting when grown in that way, as the lemon colour which is peculiar to the inferior surface of its long, handsome, and more finely divided fronds is then shown to perfection. *Gymnogramma Laucheana gigantea* is the strongest of all the Golden Ferns, its fronds, of an intense yellow on their under side, being long and more gracefully arching than those of any other

kind. But, however beautiful all these may be when seen from below, the *G. schizophylla* from Jamaica and its garden variety *gloriosa*, although nearly deprived of either silver or golden powder, are far the best of the genus for basket culture. It is a West Indian species, the fronds of which, from 20 inches to 30 inches long, are rather slender and arching regularly on all sides. It differs from all other *Gymnogrammas* by having the leafy portion of its fronds, about 3 inches broad, very finely cut, and by the remarkable peculiarity, as seen in the furcation of the

greatly resembling those of an *Adiantum*, even to the black and almost invisible stem, peculiar to the representatives of that popular genus, but the under surface is thickly coated with a yellow powder as thick and as conspicuous as that of any *Gymnogramma*. *N. nivca* is a plant similar in growth to that just described, but silvery white instead of yellow underneath. The under side of the fronds of *N. sinuata*, which frequently attain 24 inches in length, is covered with very minute white woolly scales, which produce the same effect as the white powder in the other species.

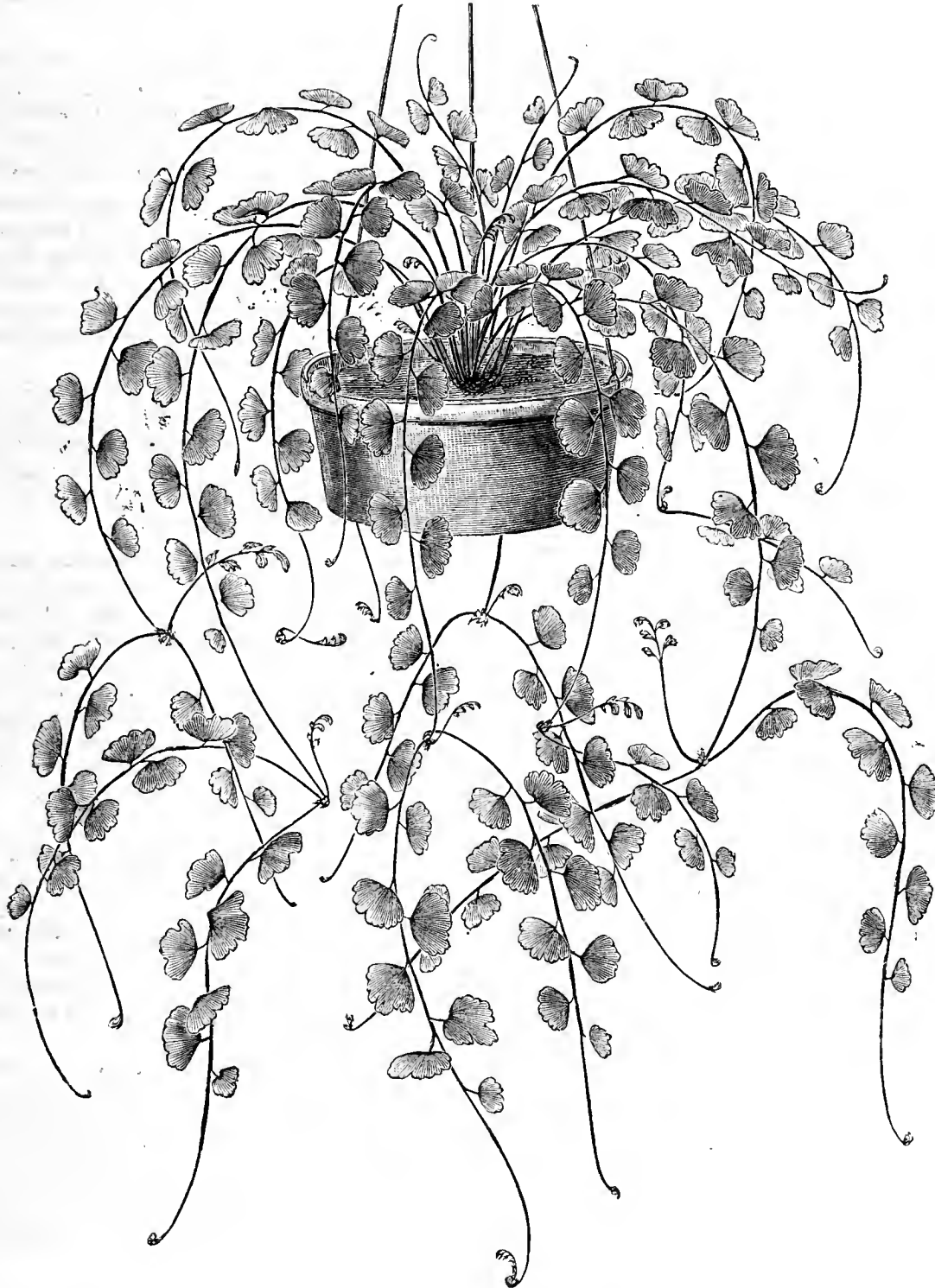

Fig. 20.—*ADIANTUM DOLABRIFORME*.

rachis at about two-thirds of its length, where it is prolific, every frond producing a young plant at the point of furcation. The very elegant contour of this Fern, its moderate size and graceful habit, its delicately cut pinnules, and also its pleasing colour, render it one of the most attractive of all our stove Ferns, and one of the very best for cultivation in suspended baskets. We must not leave the Gold and Silver Ferns without mentioning the lovely *Nothochlænas*, which have all the appearance of Gold and Silver Maidenhairs, but none of their comparatively delicate constitution. *Nothochlæna chrysophylla*, sometimes also called *N. flavens*, is an elegant plant with fronds about 12 inches long,

In addition to the above-described Ferns a few *Adiantums* also make very handsome baskets of medium dimensions, principally a crested form of the common *A. cuneatum* called *grandiceps*, the fronds of which on account of the heavy tassel situated at their summit show a drooping habit of a particularly graceful character. Then there is the lovely *A. amabile* of Peruvian origin, with fronds from 15 inches to 24 inches long, of a beautiful pale green colour, thin and membranaceous texture, and assume more gracefully curving lines than those of any other Maidenhair. The drooping character of the plant does not exclusively belong to the fronds, but is equally shared to a similar degree by their pinnae,

which, by their position, are entirely distinct from those of any other *Adiantum*. On account of its elegant and pendulous habit the charming *A. concinnum* from the West Indies is also a beautiful object for baskets of medium size. It is only when grown in that way that the real beauty of the foliage of the *Polypodium appendiculatum* can be appreciated. The crimson venation in the fronds, which average about 15 inches in length, is unique, and although it colours well in any place, still the delicate and charming network becomes more vividly coloured when exposed to the full action of the light near the glass, and the effect is much more enjoyable when the foliage is seen from below.

The Ferns used for large baskets in the warm house, though not so numerous, are, however, sufficiently plentiful, and all of a very striking character. Foremost among them is the beautiful *Goniophlebium subauriculatum*, a native of the Malay Islands; it should be grown in every stove fernery of large dimensions where a basket can be suspended. It has no equal for elegance among all the Ferns in cultivation, its graceful lively green pinnate fronds usually attaining from 6 feet to 10 feet in length. I have seen in Baron Alphonse de Rothschild's magnificent place at Ferrières, near Paris, a truly magnificent basket of it with more than forty fronds, none under 10 feet long, but with several measuring 13 feet. When such a plant is hung up in a lofty structure the effect, resembling a natural bower, is very imposing. It is also of very easy culture, and is not so particular as to a little sun as most Ferns are.

Among the genus *Nephrolepis*, which contributes largely to the Ferns adapted for baskets of considerable size, we note the superb *N. davallioides furcans* from the East Indies. It is a noble Fern, of robust growth, sending forth from a central tuft numerous arching fronds from 3 to 4 feet long. These differ from those of all other kinds by their furcation, which at the base is only rudimentary; but in the fertile pinnae the furcation is twice, and even thrice, repeated at the extremities of the first division, becoming more complete towards the point of the fronds, which on account of the weight thus produced are more pendulous than those of any other *Nephrolepis*. The next in usefulness is the new *N. rufescens tripinnatifida*, an illustration accompanying a full description of which has already appeared in the *Journal* of May 26th, page 420. *N. davallioides* and *ensifolia* are equally well adapted and frequently used for growing in large baskets, which they fill in a remarkably short space of time. The fronds of the former species, when fertile, are particularly handsome, as their pinnae are then contracted and elongated, with rounded lobes on each side and quite peculiar and elegant.

The genus *Asplenium* also contributes to the list of the basket-growing Ferns, though *A. longissimum*, a species from Penang with fronds simply pinnate, 3 feet to 4 feet long, of coriaceous texture, and of a pleasing green colour and particularly drooping habit. In *A. caudatum* we have a noble growing pendulous species from the East Indies with fronds from 2 to 3 feet long, which, like those of the above species, are proliferous at their apex. These are furnished with pinnae of a dark shining green colour, elegantly incised and unusually long, ornamented when fertile by two parallel rows of very conspicuous black sori. *Microlepia hirta cristata*, *Phlebodium aureum*, the extremely curious *Aglamorpha Meyeniana*, *Adiantum Williamsi*, and several other kinds also make splendid specimens when grown in that way. The mode of planting and the attention to be bestowed upon these baskets are in all respects similar to those given in a recent number of the *Journal* when treating of baskets for a cool fernery August 11th, page 111, and need not be repeated here.—THEO.

#### CANKER IN FRUIT TREES.

I BEG to forward for inspection a few small branches from Apple trees not long ago quite useless to all appearances through canker. Your correspondent, Mr. Hiam, on a former occasion expressed himself strongly in favour of the theory that insects were the cause of canker, and as a cure relied almost solely upon treatment of the branches by pruning and dressing. The branches sent are from trees which have been treated at the roots only, no pruning, scraping, or dressing, and I leave the judgment to the Editor.—E. BURTON.

[It is very certain the trees from which the branches were cut are very far from being "useless" now. The cankered parts of the healthy examples are healing over in the most satisfactory manner, and the growths beyond are as healthy as could be desired. In some of the cavities we find insects, but these we regard as the consequence not the cause of the canker, and if they do not soon make their escape from the trees they will be buried under the new bark. Cankered trees have been known to be cured by grafting them with a strong-growing variety, such as the Golden Noble, that has infused fresh vigour in the stock, and the cankered parts below the union have been covered with healthy bark. In saying this we do not assert that Mr. Hiam's trees are not injured by some insect with which we are not acquainted.]



WE are requested to announce that a list of plants and seeds available for distribution by the ROYAL HORTICULTURAL SOCIETY may be had on application to the Assistant Secretary, Royal Horticultural Society, South Kensington, S.W. Not seeds from Sikkim as announced last week.

— MR. E. R. CUTLER, Secretary to the GARDENERS' ROYAL BENEVOLENT INSTITUTION, informs us that the Right Hon. Sir Robert Peel, Bart., has kindly consented to take the chair at the annual friendly dinner, which takes place at Simpson's, Strand, after the annual general meeting and election of pensioners on the 13th January next.

— OXFORDSHIRE CHRYSANTHEMUM SOCIETY'S SHOW.—In consequence of the Corn Exchange, Oxford, being required for a large and important meeting (on the evening following the day originally fixed for holding the annual show) which will necessitate the erection of galleries occupying three or four days in construction, the Committee announce that the Show will be held on Wednesday, November 16th, next. Mr. Wm. Greenaway is the Secretary.

— WE regret to state that MR. HAYWOOD OF WOODHATCH LODGE, REIGATE, so well known in the horticultural world, and Hon. Treasurer of the National Rose Society, has met with a somewhat serious accident, having been thrown from his dog cart while on a visit at Sandown in the Isle of Wight. Although he is progressing favourably he has not been able to be removed.

— AT the recent meeting of the National Chrysanthemum Society's General Committee the Hon. Sec., Mr. W. Holmes, announced the death of MR. DAVID HUTT, who had been connected with the Society for many years as an exhibitor and judge. Mr. Hutt, when living at Margaret Place, London Fields, was a very successful Chrysanthemum grower, and in November, 1861, he showed six fine plants of Pompons at South Kensington, which at the request of the Queen were specially photographed. The Committee passed a unanimous vote of condolence with the family. It was also announced that the number of members of the Society had now reached 405.

— WE have received from Messrs. Robert Veitch & Son of Exeter fruit of the DYMOND PEACH grown against a wall in their nursery. This is a very fine fruit both in appearance and in quality. The skin is intensely dark next the sun, and the flesh is richly flavoured, being quite pale or only faintly tinged with red towards the stone. The tree we know by experience to be very hardy and a regular bearer. It was raised some years ago by a small nurseryman at Exeter, and was introduced by a Mr. Sharland to the notice of the late Mr. James Veitch of Exeter, who first sent it out.

— MR. W. J. MURPHY, Clonmel, writes—"Immense quantities of Mushrooms are to be had for the collecting, since the heavy rains came in the pasture fields of Ireland. Never have such quantities been noticed, and it is rather remarkable following the very dry season. So plentiful have they become that I and many others have given up using almost any other vegetable for dinner. They can be used with any dietary for breakfast, dinner, and supper, and they suit the weakest constitution."

— THE same correspondent remarking on A POTATO TRIAL, observes—"This is the heading of a note from Mr. Thomson, Clovenfords, in your last issue, and to which I should like to take exception. Surely no legitimate deduction can be drawn from the produce of one tuber or one 'shaw'—especially in such a season as that past. Then a 'trial' founded on mere weight is wholly misleading, unless the tubers are required for cattle or pig feeding. I have on trial this year new varieties of Potatoes from some of the most noted raisers in the British Islands, and some of the heaviest croppers I have so far tried are wholly unfit for human use. I am inclined to maintain that cooking quality comes first in any trial, a less number of marks being given for shape, produce, form, colour, freedom from blight, time of ripening, and any other desired special peculiarity. The Potato is a staple crop in Ireland, and



you will, therefore, be glad to hear the blight has not yet been noticed here."

— **KEEPING WALNUTS.**—"T. H. P." desires to ask if some of our correspondents will inform him of the best methods they have found of keeping Walnuts after being gathered and shelled.

— **SHERBORNE SHOW.**—We are informed that the 5-guinea silver cup that was offered for a collection of eight dishes of fruit at this Show was well won by Mr. Pullman of Frampton Court, Mr. Pragnell being a good second, the remaining prizes going to Mr. Perkins and Mr. J. Lloyd, Langport, with a mark of high commendation to Mr. Crossman, Yeovil. There were eight competitors. The Exhibition was held in the grounds of Sherborne Castle and was remarkable for the great excellence of the fruit and vegetables that were staged.

— **MR. W. IGGULDEN** writes:—"COURT PENDU PLAT, OR THE WISE APPLE is unusually prolific this season, all the trees being heavily cropped. Most of the fruit are in large clusters. On one branch about a yard long I counted forty fruit, and there are plenty more such. One short cluster about a foot in length is made up of twenty fruit, not puny 'scrumps' in either case, but fully developed well-coloured fruit. I consider Court Pendu Plat a model dessert variety. The fruits are medium sized, of good form and colour, and usually in season from December till late in April. If not gathered too soon or before the pips are brown, it keeps plump and juicy and is pleasantly flavoured. It is particularly well adapted for bush culture."

— **MR. WILLIAM COLCHESTER**, Ipswich, desires us to say he has just received a first-class certificate of merit from the Committee of the Sandy (Beds) and District Floral and Horticultural Society for pure Ichthemie Guano, the award having been made on the recommendation of the six Judges at the recent Show.

— As stated in our report of the **NEWCASTLE-ON-TYNE AUTUMN SHOW**, the attendance of visitors had been very large in the three days, and it was expected the financial results would be as satisfactory as the Exhibition was successful from a horticultural point of view. This has proved to be the case, for Mr. Jas. J. Gillespie informs us that after paying off the debt with which they commenced the year, £127, they have a balance in hand of over £300. This is highly encouraging to the Committee, and the success is well deserved.

— **"R. I."** writes:—"The long-looked-for RAIN visited mid-Sussex on the night of the 16th August, and on the following day we had our full share of the thunderstorm of that date, the rainfall being 1.19 inch; and on the morning of the 4th September we had a similar heavy rain, though not accompanied with thunder, 1.25 inch. We have had rain on sixteen days since the 16th August (twenty-two days), altogether amounting to 6 inches. The burned-up lawns and fields have become green as if by magic, and all trace of the drought has vanished. The gale on the 2nd September has done much damage in orchards about half the crop of Apples have been blown down in many cases."

— **FROM Messrs. Webb & Sons, Stourbridge**, comes a box of **ASTERS, STOCKS, AND OTHER FLOWERS** from the Kinver Seed Farms which well indicate the high character of the strains and the good culture they receive. The Asters comprise Webbs' Victoria, and Princess types in eight colours, the blooms of capital size and substance. The Stocks are of the Imperial Ten Week strain, with massive spikes and fine double flowers in several good colours, scarlet, crimson, purple, and white being very telling. Large blooms of exhibition double Zinnias were also included, with gold-striped French and fine African Marigolds.

— **"ONE** of the best border plants we have for flowering in July and August," writes **"E. M."** "is **BOCCONIA CORDATA**. Owing to its having thick fleshy roots which descend to a great depth in deeply dug soil it resists the drought in an astonishing manner. By the margin of a lake or as a specimen on grass this plant is not out of place. The foliage is of a distinct colour. A glaucous grey on the under side and a slaty green on the upper side of the leaves rendering it conspicuous anywhere. It grows from 4 to 5 feet high, each stem being surmounted with a long feathery spike of greyish white flowers. A few plants growing among the Rhododendrons, where the heads of bloom tower above the green foliage of the evergreens, are admirable."

— **THE** following summary of **METEOROLOGICAL OBSERVATIONS** for August, 1887, at Hodsoek Priory, Worksop, Notts, has been forwarded

by Mr. Joseph Mallender. Mean temperature of month, 58.7°. Maximum on the 6th, 83.2°; minimum on the 14th, 35.4°. Maximum in the sun on the 6th, 137.9°; minimum on the grass on the 14th, 27.4°. Mean temperature of the air at 9 A.M., 61.2°. Mean temperature of soil 1 foot deep, 59.8°. The temperature fell below 32° on three nights. Total duration of sunshine in month, 176 hours, or 39 per cent. of possible duration; three sunless days. Total rainfall, 1.45 inch. Maximum fall in twenty-four hours on the 30th, 0.57 inch. Rain fell on ten days. Average velocity of wind, 6.6 miles per hour. Velocity exceeded 400 miles on one day, and fell short of 100 miles on eleven days. Approximate averages for August.—Mean temperature 60.2°. Rainfall, 2.52 inches. Sunshine (six years) 150 hours. Another dry and bright month, with warm days and cold nights. The rain of the last few days was most welcome.

— **GARDENING APPOINTMENTS.**—Mr. Thomas Cross has succeeded Mr. J. Chesher as gardener to Francis James, Esq., Edgworth Manor, near Cirencester, Gloucester. Mr. E. White, late gardener to S. Soames, Esq., Cranford Hall, Kettering, is now gardener to Capt. Walker, Rock House, Cromford, near Derby.

— **A CORRESPONDENT** would like to mention that he has several bushes of **MADAME GABRIEL LUIZET ROSE** coming into full bloom. He thought it was not supposed to be an autumn bloomer. His bushes, however, we think are not singular in flowering now; we have seen beautiful autumn blooms of this variety.

— **ALL** requiring a large stock in the spring of **MESEMBRYANTHEMUM CORDIFOLIUM VARIEGATUM** for bedding purposes would do well to insert cuttings now, that no difficulty may be encountered when the time comes for increasing the stock. It often happens that a sufficient number of good cuttings cannot be had when wanted through the stock plants intended to supply them being lost during the winter. The best method to secure sufficient stock plants is to insert cuttings now in a shallow cold frame. If the bottom of the frame be dry, say a thick layer of ashes, nothing more is necessary than placing on the ashes 3 inches thick of sandy soil, refuse from the pottling bench sifted, with a little decomposed leaf soil and plenty of coarse silver sand, with a layer of the latter on the top, pressing all firmly down, and sprinkling with water through a rose can. Prepare the cuttings about 2 inches long, those not having bloom shoots attached are the best, insert them firmly, gently water again to settle the soil about them, keep the frame close, except giving a little air occasionally to dissipate condensed moisture, shading from hot sun. When the cuttings are rooted transfer them to boxes or pans, preserve them from frost. These plants will produce more cuttings in the spring than old plants lifted.

— **MESSRS. WILLIAM PAUL & SON**, Waltham Cross, send us blooms of **ROSE DUCHESS OF ALBANY**, a new variety to be sent out next spring, and one that is likely to gain considerable favour amongst Rose growers. It is of the same habit as La France, equally free and fragrant; the bloom also is similar in build, but it is totally distinct in colour, both surfaces of the petals being of a rich dark rose tint. In the bud state it is extremely beautiful. For bouquets, buttonholes, wreaths, or, indeed, any decorative purpose, it is admirable. A gentleman of excellent taste to whom we showed the blooms is quite enthusiastic in its praise, and emphatically pronounces it to be "a true artist's flower."

— **A CORRESPONDENT** states that, according to a Cologne paper, Baron Nathaniel de Rothschild—not the chief of the great plutocratic house—has been expelled from Vienna. The Baron is a great florist, and in all his villas and castles carries on the culture of rare exotic plants upon a very costly scale. The Archduke Karl Ludwig, the Emperor's brother, visited one of the Baron's gardens during the absence of the owner, in order to get a glimpse of some of his rare plants. The Archduke is the foremost patron of art and science in the Empire, and a great favourite with the cultivated classes and the people. Baron de Rothschild had given the order that no one should be allowed to inspect his forcing houses during his absence, but the head gardener conceived that the order could not extend to so important a person, and so admitted the Archduke. When the Baron heard that his order had been disobeyed he at once dismissed the head gardener. The Archduke wrote to the Baron begging him to revoke the dismissal. The great monetary prince, however, would not grant the petition of the Imperial Prince. The Municipality of Vienna were indignant at this rudeness to the most popular and

liberal member of the Imperial family, and gave the Baron to understand that he must either concede the Archduke's request or forfeit his own citizenship. The Baron chose the latter alternative, and has voluntarily ceased to be an "Austrian."

— MESSRS. J. LAING & SONS have had a grand display of BEGONIAS AT FOREST HILL this season, both indoors and out; but the outside beds are even now a brilliant mass of colours, and will continue gay until the frosts cut the plants down. In a series of beds running at right angles with the main road, 50,000 seedlings are planted out, and some idea of their merit can be formed when it is stated that in size, form, and colours the flowers are equal to the best named varieties of recent years. Many are 5 inches in diameter, thick, bold, erect, substantial blooms, fit to stand any weather. Much improvement has been effected in the habit of these plants; they are now compact and sturdy in growth, the flowers are borne well above the foliage, not so drooping as formerly, and their value for bedding purposes has been proved beyond all doubt. They are arranged in a dozen tints, but the scarlet, crimson, rose, and orange varieties are extremely effective in masses, and the appearance of the beds has been improved by the introduction at intervals of a few plants of green and variegated Maize, a dwarf form of the latter affording a fine contrast with the rich colours of the Begonias.

— "C. O." sends the following note on DAMSONS AND PLUMS:— "A striking example of the superiority of the Farleigh Damson over the old variety for free and early bearing is exemplified in the gardens of Mr. Will Tayler of New Hampton, Middlesex, where young two-year-old trees are growing loaded with fruit clustering around the stem of the last year's growth, while there is not a fruit to be seen on trees of the old common variety of the same age growing side by side. At Farleigh in Kent, where this variety originated, and from whence it takes its name, I have seen trees planted in hedgerows around gardens and pastures. The trees annually produce a good crop of fruit, and are both ornamental and profitable. There are no doubt many hedgerows in gardens that might be planted with advantage in the same way. The Czar Plum is a comparatively new variety that Mr. Tayler finds a large demand for. It is a round, dark, early fruit, coming in before the Early Orleans, a sure and free bearer; Grand Duke is a good companion to this as a late Plum. It bears freely, and will hang until the beginning of October without showing any signs of cracking. A very striking variety is Pershore, with fruit of a clear bright golden-amber colour; a sweet and good juicy fruit. It is grown somewhat largely in the Midland counties for the market."

— GLADIOLUS BRECHLEYENSIS.—This Gladiolus is very useful for planting among clumps of hardy Azaleas, Kalmias, Heaths, dwarf Rhododendrons, and all young low growing American plants. Coming into flower during August and September, its brilliant scarlet spikes brighten up the otherwise sombre hued beds, and such plants are admittedly dull looking when not in flower. Strong flowering corms of this Gladiolus can be had at 7s. 6d. per 100; they are taken up when the flower spikes die away, carefully dried, cleaned and stored. They last many seasons, increasing in size and number, so that a good stock may be quickly secured. Plant the corms in March 3 to 4 inches deep, placing them on a little sand, which encourages quicker root action afterwards. The peaty soil used for the American plants suits them admirably. A good companion is John Bull, an almost white variety having a tinge of delicate pink in its flowers; it forms a good contrast to the scarlet sort.

### HOLLYHOCKS.

REFERRING to Mr. Steel's remarks in the Journal of September 8th, I in no way wish to depreciate the good work done by Mr. Blundell in reference to the Hollyhock, as from what I have seen of the flowers he sent to me, he is obtaining some fine varieties, but Hollyhocks reached such a very high state of perfection in the old days of Turner, Paul, Clater, Parsons, Bireham, Roake, Bragg, and others. This perfection of form was the work of years, and the Hollyhock having been so long a neglected flower, and only recently taken in hand again, we cannot reasonably look for absolute perfection just yet.

I am very pleased to see that growers are springing up about the country, and we shall shortly find the Hollyhock taking a very foremost place in popularity, and it is to be hoped for that the August Flower Show Committees will see their way to give special prizes for, say, six spikes and twelve cut blooms to begin with, for remembering so well as I do the old Hollyhock days when the flower occupied prominent places at our late summer shows, and were striking features there, I am

certain that these being reinstated in schedules would soon bring exhibitors forward at the flower shows.

One thing is a certainty, that very fine varieties can be had from seed, but to get strong flowering plants *early* the seed should be sown in the autumn, and the plants protected. Seed sown in February and grown on make good flowering plants in August and September. In cold districts they do not grow so quickly as in more favoured places. Will Mr. Steel kindly give a list of the old varieties he possesses? and I am sure that his kindly notes will tempt many, not at present growers, to take up the Hollyhock.—W. DEAN, *Florist, Walsall.*

### GRAPES AT THE CRYSTAL PALACE, SEPT. 2ND, 1887 THE WAIL OF A DISAPPOINTED EXHIBITOR.

IT is seldom necessary or desirable to take notice of what may be said about one in the public press, but as some of my fellow Judges seem anxious to be exculpated I have no hesitation in coming forward and stating that I am one of the wicked Judges referred to by Mr. Ward in your last week's issue—Mr. Burnett and Mr. Coomber being my colleagues—and that I have no intention of evading my share of the responsibility. It is well to note Mr. Ward's statement that he does "not write as a disappointed exhibitor;" yet it is scarcely possible to assign to him any other position. What is the terrible sin we have committed? Simply our failing to estimate his collection of Grapes in the same order of merit as he had done himself, and using our discretionary powers by withholding the first and second prizes and awarding the third only. It seems to be generally admitted that it was quite in order to withhold the first prize, but quite wrong to do more. We did so, however, and deliberately and unanimously, on the grounds—Firstly, that they were quite second-rate in quality, not a single sort if put into competition in the other classes would have secured a place; and, secondly, they were not fresh. This was notorious. The Madresfield Court and several others had the stalks quite withered and in very bad condition. These had evidently been about to other shows and had got used up. Is it expected that stale Grapes are to carry off leading prizes at a great fruit show like this in the month of September because there is no competition? What would be the value of such Grapes in Covent Garden? Dare Mr. Ward have put these Grapes on his employer's table? Not good enough for that, perhaps, but to snatch a prize with it seems to be quite another matter.

We feel terribly frightened at the array of great names Mr. Ward puts up in evidence against our decision, and the mere mention of the ducal magnate, who, by-the-way, has no name or address, fills me with dismay. It is but natural that exhibitors, especially those who make exhibiting a trade, should sympathise with each other and find fault with the Judges when they discover the prizes are slipping away from them. The Grapes generally were of a high standard, but on referring to the prize lists it will be found that they were mostly taken by new exhibitors, the old and regular habitués being obliged to take a back seat. This is in itself a gratifying fact, and as it should be. This is according to the laws of Nature. This is the fate of all Grape growers—a little while victorious, then a gradual decline. It would be well for Mr. Ward and others to note this, that if their threatened retirement takes place to-morrow they are only making room for others to come to the front. The bumptious threat of withdrawing their patronage is almost too good. Is it expected that this will cause a panic amongst the shareholders? Patronage, indeed! It was really not necessary to invoke such an awful calamity on my account. I have always thought that if such a thing existed it was on the other side. But Mr. Ward is not egotistical. No. Mr. Ward's instructions to the Crystal Palace authorities are truly excellent, and will no doubt receive due attention. They do not go far enough, however. I would suggest that every exhibitor be allowed to appoint his own Judge, for out of the multitude wisdom might come. Having lost Mr. Ward's confidence I may never be able to join that happy band, or to make any amends for my recent misdeeds.—A. F. BARRON.

[Relative to the judging at the above Show, one of the best of fruit growers and a successful exhibitor, but not a competitor in the Grape classes at the Crystal Palace, writes: "I note Mr. Ward is expressing his dissatisfaction in various directions. He would have done better to have swallowed the verdicts in my opinion. Possibly his Grapes were worth second, they were decidedly not worth first, for on looking into several of the bunches closely I noticed the stems were discoloured, showing they had either been kept for some time after cutting or else badly finished. What most surprised me in the Grape judging was Mr. Pratt being placed third for Muscats, and also for a basket of white Grapes. I considered he was a good second in both instances; but if one goes in for showing he must put up with much disappointment at times. I have had my share."]

### MILDEW ON ROSES.

IN late autumn or early winter it is no uncommon occurrence to discuss the probable cause of mildew on outside Roses. Frequently by that time the weather has been of a variable character, and wet cold autumns are more usually considered to be the cause of the plants becoming a prey to this disease. I have repeatedly pointed out that this is not the sole cause. I do not doubt that prolonged rain, combined with cold days and nights, will not only aid its development, but bring all dormant spores into full activity, but at the same time the real origin of the disease may have been overlooked. To find out the exact conditions under which it will start into existence and spread most rapidly is

knowledge of the utmost importance to enable us to arrest its progress. If a cold saturated atmosphere alone were the cause, then the task would be hopeless.

Mildew will, however, spring into life and spread as quickly when the plants suffer by drought as is the case by the opposite extreme. This season so far could not have been better up to the present time to harden the wood. It has been a good season for Roses in the north; they certainly came all at once, but the quality throughout has been good. It has been too dry I admit, and to this I think the appearance of mildew may in many instances be traced.

The condition of Roses, whether attacked generally or otherwise, would be instructive at the present time; the position and nature of the soil, too, are of great importance in determining satisfactorily whether the disease springs more readily from hot dry weather than the opposite. On light shallow soil the plants would undoubtedly suffer first, and then on those of a heavy nature, unless the surface was mulched. It is surprising what a length of time the soil can be kept in a moderately moist state by mulching early in the season. To do this operation late in the season when the ground has become dry is next to useless. I do not doubt that plants, whether on light or heavy soil, if mulched early will still be free of mildew. If this practice has not been carried out, or the surface stirred frequently, then probably the plants are already attacked by mildew, and at the first suitable change it will spread rapidly. Roses with poor constitutions, or those in bad health, are chiefly the victims upon which the spores of mildew first germinate.—W. B.

### AROUND NEWCASTLE-UPON-TYNE.

IN leaving Jesmond Dene at the waterfall end recently noted in these pages, it was remarked that a road is reached to the left skirting the Dene, and standing off this are several mansions, amongst them being Lord Armstrong's private residence and garden, also known as Jesmond Dene. Though only of moderate size, comprising some twelve acres, the garden is replete with horticultural interest, for it has been the careful study of Lady Armstrong during many years to enrich it with choice collections of tender and hardy exotic plants distinguished by the beauty and fragrance of their flowers. Borders of herbaceous plants, including many old garden favourites, abound out of doors, while under glass there is the same freedom from formality in the occupants of the houses and the way they are arranged. Roofs, walls, and pillars are covered with luxuriantly growing and profusely flowering climbers; specimen plants are not rigidly trained to trellises, but allowed to assume somewhat of their natural habit. The chief points kept in view are, obtaining as large a supply of flowers as possible, and growing the plants without the restriction too often considered necessary in gardens. Considerable house space is consequently required, and about fifteen houses are mainly devoted to the plant collection, stoves, conservatories, greenhouses, and ferneries being all fully occupied. The ferneries are very remarkable structures, much taste having been employed in their formation and planting. They are now well furnished, having a very natural appearance, the huge pieces of rock used in their construction having been taken possession of by thousands of young Ferns and Mosses, which effectually clothe them. The larger fernery is a somewhat lofty house, containing a fine *Chamaerops excelsa* bearing its leaves to the base of the stem, and *Cyathea dealbata* with other Tree Ferns reaching the height of 25 to 30 feet. *Cyathea medullaris* and *C. Schiedei* are especially noticeable amongst the larger Ferns; then at the upper part is a great plant of *Monstera deliciosa*, which produces its fruits freely and grows luxuriantly. *Hoya carnosa* is another plant that seems to be thoroughly at home scrambling about at the upper part of the house, and is nearly always in flower. The fine-foilage *Begonias* of the Rex type impart a distinctive character to the house, *Nephrolepis* of several species, the graceful *Pteris scaberula* and *Adiantum cardiochloena* being also conspicuous occupants of the house. From a passage outside a gallery can be reached commanding a pretty view of the Ferns, but at the lower portion there is a winding path leading to another picturesque fernery of similar design containing cool little nooks and recesses where *Todeas* and *Trichomanes* flourish. In this there is also a variety of other plants besides Ferns which thrive in a moist, shady position; very noticeable is the rich velvety green *Mikania pulverulenta*, which trails over a large rock, completely covering it with its beautiful foliage. *Fittonias Verschaffelti* and *argyroneura* grow very strongly, some leaves of the former measuring 8 inches long by 6 inches broad, the veins dark and distinct. Grown in pots with the best treatment, these plants are seldom seen in such fine condition. The blue-tinted *Selaginella cecilia* also does well, and has a fine metallic-like lustre amongst the numerous *Adiantums* and other Ferns with light green fronds. *Stanhopeas* are suspended from the roof, *S. insignis* and *S. tigrina* being the chief favourites, fine old specimens that produce from seven to ten spikes each. One of the paths is overhung by strongly growing plants of *Rhododendron volubile* and *Plumbago capensis*, quite unusual features in a fernery, but the effect is charming.

A spacious span-roof conservatory near the ferneries contains a surprising number of plants, the climbers on the roof and pillars being extremely luxuriant. On a wall at the end is a fine old specimen of the Night-blooming *Cereus*, which has had a number of its great trumpet flowers this season. Climbing up the roof are *Solanum jasminoides*, the blue and scarlet *Kennedya monophylla* and *coccinea*, *Taesonias insignis* and *Van Volxemi*, the profuse white *Clematis indivisa lobata*, *Passiflora Imperatrice Eugenie*, and the gracefully drooping *Acacia*

*Riceana*. Upon a rockery at the side of the path many plants are placed out, the *Gleichenias* seeming well satisfied with this treatment, though some find them troublesome in pots. The centre bed is occupied with numerous large plants, an unusually fine variety of *Pancreatium fragrans* being an especial favourite, one plant having two large scapes of ten to twelve flowers each.

A stove near the house is similarly well supplied with climbing plants, *Ipomoea Leari* having a grand effect on the roof, covered with its large bright blue funnel-shaped flowers. *Bougainvillea glabra*, *Stephanotis floribunda*, *Allamandas*, *Justicias*, and *Hibiscuses* are all employed as wall or roof coverers, and the last named, of which there are several varieties, have a particularly fine appearance. In an adjoining conservatory are some large old *Camellias*, such as *Lady Hume's Blush*, the old double white, and *Paoniflora*, which have been planted out for thirty-five years. They are now quite tree-like in size, perfectly healthy, and yield their flowers in enormous numbers. In another stove is a good collection of Pitcher Plants. Orchids are well represented, *Peristeria elata* succeeding uncommonly well, one specimen, 3 feet in diameter, having had nine spikes of flowers. There is a good general collection of cool Orchids with *Sarracenias*, and a house devoted to Roses, from which flowers are obtained ten months out of the twelve.

The houses appropriated to fruit culture are not very numerous, but Vines and Peaches receive the best attention with excellent results. The kitchen garden is a special feature at Jesmond Dene, and it was surprising in such a season to find healthy rows of Peas still in full bearing. Veitch's Perfection was remarkably fine in this respect, succeeding capitally, while a late variety named *George Stephenson*, recently sent out by Messrs. Fell & Co., Hexham, was very noticeable. It is about 5½ feet high, very prolific, the pods well filled, and the flavour good. Mr. Elliott speaks highly of its merits. A handsome red Celery, the *Wentworth Solid Red*, is also a specialty here, having been grown for some thirteen years; it is very hardy, never runs, is of good quality, and is lifted up till April. Of small fruits, Gooseberries, Currants, &c., have considerable space devoted to them, a large border being netted over to keep a late supply, *Baumforth's Seedling* and *Northumberland Red* are the favourite Raspberries, while of Strawberries both *James Veitch* and *British Queen* are much prized.

The shrubberies, lawns, rockeries, bog garden, Fern dells, and mixed borders all present interesting features, and every department shows the results of Mr. Elliott's skilful superintendence.

### HEATHFIELD HOUSE.

Near the Saltwell Park, Gateshead, incidentally noted in a previous article, is Heathfield House, the residence of Theodore Lange, Esq., and which comprises in a space of 8 or 10 acres quite a model suburban garden. The site is an elevated one, sloping steeply to the Team Valley, and affords another instance of the agreeable views to be obtained in several districts around Newcastle. The hills on the opposite side of the valley are densely wooded towards the left, and closely surrounded by trees Ravensworth Castle can be just discerned, while to the right the valley opens out to the Tyne and the smoke of Elswick. There are advantages and disadvantages in dealing with gardens on steep slopes like these. They usually admit of a much more picturesque effect being produced in the laying out, but the expense is great, especially as regards glass structures. Mr. Lange was, however, determined to render his garden both ornamental and useful, and a cursory inspection proves how well, with the aid of his energetic gardener, Mr. Methven, he has succeeded.

The garden slopes from east to west, and at one side facing south a magnificent range of glass houses has been erected 360 feet long. It is built on three terraces with an octagon conservatory in the centre, a lean-to vinery and Peach house, and a span-roof intermediate house at the upper, with two lean-to vineries and a span stove at the other side. The two end houses stand at right angles to the vineries, and a high lantern runs the whole length of the houses. The whole range is most substantially built, resting on stone foundations and walls, with ornamental balustrades and spacious flights of steps from the several terraces, the general work having been satisfactorily carried out by Mackenzie and Moncur of Edinburgh. No expense was spared, and Mr. Lange has now the satisfaction of owning one of the most handsome and best constructed ranges in the district. Beginning at the lower house we may briefly glance at the contents of the various divisions. The stove is chiefly occupied with the well-grown specimen *Crotons* and other plants which have so frequently won honours at Newcastle and elsewhere. *Crotons Queen Victoria* and *majesticus* in particular are very fine, 9 feet high and 7 or 8 feet in diameter, in splendid health. *Allamandas*, *Rondeletia speciosa*, *Eucharises*, and *Pancreatium speciosum* are all represented by large plants, two specimens of *Eucharis* having had forty and thirty-eight spikes each. Numbers of *Dendrobiums* are also grown in this house, such as *D. nobile*, *D. thyrsoflorum*, *D. crassinode*, and *D. Wardianum*. In the adjoining vinery are grown the early Grapes, fine vigorous Vines six years planted of *Black Hamburg*, *Foster's Seedling*, and *Buekland Sweetwater*, from which fine bunches have been had this year, some of the first-named running between 3 and 4 lbs. In the next house every second Vine is *Madresfield Court* remarkably well cropped, and this, with free growth and ventilation, effectually stops cracking. *Muscat of Alexandria* and *Cannon Hall Muscat* are also successfully grown.

The octagon house in the centre is chiefly filled with *Erics*, some fine specimens being 6 feet across, but it is used at other times for general flowering plants. The late vinery follows this, *Gros Colman*, *Alicante*, and



Raisin de Calabre being the varieties, and with 25 feet run of rod they present a fine appearance loaded with Grapes. The Peach house is filled with a number of healthy trees on front and cross trellises and right angles with the path. The whole available space is thus fully occupied, and Mr. Methven finds the crops from the cross trees quite as satisfactory in all points as the others. Stirling Castle, Royal George, Noblesse, and Rivers' Early York are the leading varieties, the last named being ripe ten days before any other. Pine Apple and Violette Hâtive Nectarines are similarly good, and all had some handsome fruits at the time of my visit. The intermediate house is devoted to specimen Cycads, Ferns, and some Orchids, adjoining that being a picturesque rock fernery tastefully designed and planted. The rocks are covered with Ivy, *Ficus minima*, *Tradescantias*, small Ferns, and *Begonias*, larger Ferns being introduced in suitable positions.

Besides this range there are several other older houses which originally constituted all the glass attached to the garden; these are now devoted to late Peaches, miscellaneous ornamental plants and Orchids. Of the latter a good collection has been formed, and many valuable specimens are now grown, including *Cattleyas*, *Lælias*, *Odontoglossums*, *Cypripediums*, *Dendrobium*, &c., which appear to flourish under Mr. Methven's charge. A *Dendrobium* which has attracted some attention is *D. Cooksonianum*, or *Heathfieldianum* as it is now termed; it is said to have been raised from seed obtained at Heathfield by crossing *D. nobile* with *D. Falconeri*. The seeds were sown and the first plant flowered about six years ago. In 1883 some plants were exchanged with Mr. Cookson of Wylam-on-Tyne, and amongst these was a plant of this *Dendrobium*, which is remarkable as showing an example of *peloria*—that is, it has the two petals similar to the lip in shape and colour, so that at first glance it looks as if the flower had three lips. Mr. Cookson's plant flowered in 1885, and was shown on March 10th at South Kensington under the name of *D. nobilissimum*. Prof. Reichenbach, through some misunderstanding, subsequently named it *D. nobile Cooksonianum*, and it was not until recently that the plant became known under its corrected and since appropriate name of *D. Heathfieldianum*.

The outside garden is charmingly diversified by rockery slopes and shrubberies, well kept lawns, a pretty lake, and an effective flower garden. The principal beds are on a lawn near the glass house, a large circular border around a fountain having a fine appearance, *Pyrethrum selaginoides* and Dell's Crimson Beet being boldly contrasted together with two excellent *Lobelias*—*Bella*, pure white, of good habit, very free and pure, and *Heathfield Gem*, rich blue, very clear and bright, and compact habit. A rockery termed "the Miniature Mont Blanc" the summit of which is reached by a rocky path, commands fine views of the valley already mentioned, and adds an interesting feature to the garden. It should be added that Mr. Methven is a successful *Chrysanthemum* grower, and his plants this year look very promising. Some hundreds of strong plants are grown, representing a selection of the best exhibition and decorative varieties, and the blooms from this garden have taken honours on more than one occasion at the north country shows.—LEWIS CASTLE.

### METHODS OF PRUNING VINES.

IT is useless arguing with Mr. Abbey. First he advocates a practice, then condemns it; then when faced with his own words complacently remarks he had never denied or objected to anything I had said, but went in the "opposite direction." That appears to be his favourite course. A short time ago he knew all about modified spur pruning, which he advocated; now he says he does not understand it. He believes the Vine particularly adapted to spur pruning, because it "never forms spurs naturally or culturally." He knows the Cole Orton Vines failed when spur pruned (which they did not because it was never tried on them), therefore he recommends the opposite system; next he gives us a soliloquy on buds, and imparts the edifying information that a "bud is a bud," and that he "knows very little about bud-formation." First he knows everything, then he knows nothing; but he continues, as if against his own desire, to confirm all I have advanced, and does not appear to know it. That suits me very well, and I hope it suits him. As there is no hope of my teaching Mr. Abbey to prune Vines I will refer him to a paragraph in "Work for the Week" of the same issue in which his celebrated "know nothing" communication appears—namely September 1st, page 193. I had not the honour of writing that paragraph, but it expresses very concisely my views on pruning Vines, and shows that a cast iron system is not applicable to all of them. If my obliging friend cannot follow the observations there recorded, and will oblige me with his address through the Editor, I will endeavour to give him an object lesson, and if he does not have a better crop of Grapes in consequence I will not charge him for my journey. I should like to do something for him in return for the support he has given to me, though he makes it appear as if travelling in the path he evidently enjoys—the "opposite direction." I have now done with the subject on paper at present, for I begin to perceive a versatile controversialist is like Tennyson's Brook, and may "go on for ever."—EXPERIENTIA DOCET.

### PÆONIA ALBIFLORA.

AMONGST the herbaceous *Pæonies* cultivated in our gardens no one species has played such an important part in the vast improvement that has taken place within the last few years as this Chinese *Pæony*, of which we give an illustration. After a long season of entire neglect,

unless in the old fashioned gardens, these plants are now taking their proper place among cultivated plants, and few flowers give a greater pleasure to the grower, or a greater scope in the arrangement of colour. The great essential to their success is no doubt moisture, and where this can be given in abundance all through the growing and flowering season a fine show of strong plants and well coloured flowers will result. A situation where they can be irrigated at pleasure is the one recommended for *Pæonies*, but every grower cannot do this, and our plan is to mulch heavily with old spent manure as soon as the leaves die down, freshening it up as they begin to grow in spring, and keeping well watered until after the flowering season is over. Even solitary plants in borders do very well with a mulching of leaves or manure round the stem. Where facilities offer they should be planted in the wood or other available shady spot. They will be found to do well, and flower a fortnight or so later than those exposed. They can be propagated to almost any extent by division, but they also ripen seed freely, and these sown as soon as collected soon germinate.

The following are the original varieties or types from which our fine garden forms have been raised.

*P. albiflora*.—This is the type or origin of the great host of garden varieties now in cultivation. It is very distinct from all the other species of *Pæony*, and may be known at a glance by the dark green leaves, and also by the way in which the flower stems stand out above the foliage. It grows about 2 or 3 feet in height, with stems about the thickness of a reed, round, and with scarcely conspicuous grooves, green tinged red and generally naked at the bottom; leaves ternate, leaflets lobed and shining. The flowers are often produced three in a bunch, with the axils of the uppermost leaves throwing out long fastigate stems. Petals very large, milk white, oval, concave, the seeds when ripe being of a yellowish colour. It differs from the common *P. officinalis*—first, in having a more slender stem, rounder, less conspicuously grooved, and more rigid, while in *officinalis* the stems are torosely six or seven grooved; second in having larger biternate leaves, broader, smoother leaflets, shining on both surfaces. In *officinalis* the leaves are subtriquinate or triternate, with the primary leaflets bifid; the lateral ones often with a small accessory leaflet; *albiflora* differs also in having smooth follicles, while they are hairy in the other. It is a native of Siberia and China, and said to be well known among the Daurians and Mongols on account of the roots which they boil in their broth, and the seeds which are ground and put into tea. Of this species Anderson, who published a fine monograph in the twelfth volume of the Linnæan Society's Transactions, described nine distinct varieties believed to have been introduced from the native habitats of the species, which is, found both wild and cultivated all over the Chinese Empire.

*P. a. var. candida*.—This variety was first found at Knight's Nursery, King's Road, Chelsea. It was received under the name of *sibirica*, name it often goes under even now. The leaves and stalks are purplish, few flowers in a cyme and flesh-coloured stigmas, flowers pinkish on first opening but go off white. The engraving (fig. 30) represents a flower received from Mr. T. S. Ware.

*P. a. var. fragrans*.—This fine double-flowered variety was introduced from China by Sir J. Banks, 1805. It is most remarkable for its upright stalks and pale very narrow leaves. It flowers about the latter end of June, and is the latest of all the *Pæonies*, petals pale rose-coloured, with a fragrance somewhat resembling the Rose; the central petals are larger than the outer ones, and always erect.

*P. a. var. Humei*.—Introduced from China by Sir A. Hume in 1810. It is the largest of all the herbaceous *Pæonies*, the stems often attaining 5 or 6 feet in height, flowers very double, reddish coloured, somewhat similar to above in shape, but almost scentless.

*P. a. var. rubescens*.—A very small variety with dark coloured flowers; leaflets small, blunt, and channelled on the upper surface.

*P. a. var. sibirica*.—Said to have been sent from Siberia by Pallas; leaves yellowish green, flowers very large and pure white, even in bud; stalks quite green.

*P. a. var. tatarica*.—Native of Tartary; flowers large, with a greater number of petals than the *vestalis*, pink coloured, retaining the same shade until they drop; stigmas pink.

*P. a. var. uniflora* has very narrow leaflets, and a disposition to be one-flowered; petals white, slightly tinged with pink at the base; stigmas dark yellow.

*P. a. var. vestalis*.—Large white-flowered, rarely tinged with pink cymes of two or three flowers; leaves broader, more flat and shiny than the type; stigmas dull yellow.

*P. a. var. Whitleyi*.—Introduced in 1808 from China. The stems are full 3 feet in height; leaflets rugose, and dull flowers full double, outside petals reddish, inner pale straw-coloured, becoming white as they drop. The fragrance resembles that of Elder flowers. Middle of June. There are many more forms or varieties all worthy of attention; indeed, we believe they now number something like 150, and may be seen at any large florists; they represent almost every shade of pink, red, &c., and also very much in form, height, &c.—M. S.

### STRAWBERRY RUNNERS FOR FORCING.

IT must be at once admitted, as pointed out by your correspondents, Mr. A. Young and "Thinker," that split crown plants are not desirable for early forcing, and that runners procured the previous autumn do produce a greater proportion of such plants than those of the current year. I do not consider this a very serious objection to the system. When the plants are placed in their fruiting pots they are reduced to a

clean single crown, and potted rather deeply. Vicmtesse de Thury is the worst for splitting; the greater part of them, moreover, will have

thousands more, am very hard pressed with work during June and early July, when runners have to be got in, and would be very likely to be



Fig. 30.—PEONIA ALBIFLORA.

one leading crown, to which it may be reduced by pulling the weaker side shoots off during August. President, of which we grow the greatest number, produces very few split crowns, not over 10 per cent. I, like

put off from day to day when runners are plentiful. During August and September we have more time, when any irregularity of growth may be rectified.—R. INGLIS.



## HORTICULTURAL SHOWS.

### ROYAL CALEDONIAN HORTICULTURAL SOCIETY.

THE autumn Show, held on Wednesday and Thursday, Sept. 7th and 8th, in the Waverley Market, Edinburgh, contained more entries for fruit than any previous exhibition held by the Society, there being no fewer than 1002 in this important section, representing about 2000 dishes, taking the numerous collections of various kinds of fruit into consideration. Of Grapes alone there were 450 bunches. Apples were very largely shown, Lord Suffield alone being represented by about seventy dishes. Vegetables were next in extent to fruit, there being over 400 entries. Plants were not conspicuously shown, and cut flowers only fairly numerous. There were something like 500 entries more than usual at this autumn exhibition.

As usual, the collection of fruit, and the exhibition of Grapes in collections and in varieties, were the chief features of the Show.

#### FRUIT.

Gardeners and amateurs.—Class 1, Fruit (open to all).—For a collection of twelve dishes of fruit, to consist of three dishes of Grapes (not less than three varieties), two dishes of Peaches, and one dish of each other kind of fruit, Pine Apples and Bananas excluded, the first prize, a silver tea set, value 10 guineas, presented by Messrs. Mackenzie & Moncur, Horticultural Builders, Edinburgh, there were no fewer than thirteen collections staged, almost every one of which was meritorious to a high degree. Mr. Boyd, gardener to W. Forbes, Esq., Callander House, Falkirk, was successful in securing the first prize, his Grapes being of extra fine quality, and comprising Black Alicante of good size and extra finish; Muscat Hamburg was very large in bunch, and of the very finest finish possible, and jet black; Black Hamburg also very fine. The other dishes were Jubilee Melon, Grosse Mignonne and another Peach, small Etruge Neotaries, and Figs, Plums, Apicots, Jargonelle Pears, and Passiflora edulis being the other dishes. The Grapes doubtless exercised a very great influence in this case. Mr. McKelvie, gardener to the Duchess of Roxburgh, Broxmouth Park, Dunbar, second, the white Muscats in this collection being extremely fine; Muscat Hamburg and Black Hamburg were the other Grapes, and not so fine, though good. A fine Best of All Melon, good Brown Turkey Figs, extra Walburton Admirable and Barrington Peaches, were the most noticeable of the other dishes. The third prize was secured by Mr. McIndoe, Hutton Hall, Gaisborough, York, the Gros Maroc and Gros Colman Grapes being very fine, the other sort being Trebbiano. The other fruit in this collection was much better than in the other two, Best of All Melon, Golden Eagle and Princess of Wales Peaches, fine Figs, and Jargonelle Pears, Jefferson Plums, and extra Ribston Pippin Apples, being all fine. Mr. McKinnon, Melville Castle, Lasswade, was fourth, Buckland Sweet-water Grapes were very fine, Black Hamburg not so good, though large, and enormous Trebbiano; Barrington Peaches were also fine. Mr. Hunter, Lambton Castle, Dnrham, also staged well; Mr. Murray, Maybole, and Mr. McHattie, Newbattie Abbey, also having fine collections.

For a collection of eight dishes of fruit, not more than two dishes of Grapes (black and white), and one dish of each other kind of fruit, there were six entries, Mr. Hunter being first with Grapes, small in bunch, but of fine finish and extra fine Souvenir du Congrès Pears, Smooth Cayenne Pine Apple, La Favourite Melon, Apples, Plums, and Nectarines. Second Mr. McIndoe, with very fine Gros Maroc, Charlotte Rothschild Pine Apple, fine Walburton Peaches, and Clapp's Favourite Pears.

A collection of twelve dishes of hardy fruit, not more than two dishes (distinct varieties) of each kind, and all grown out of doors, nine entries, Mr. Fairgrieve, gardener to the Duchess of Athole, Dunkeld, was first with large Royal George and Rivers' Early Silver Peaches, good; Pitmaston Orange and Etruge Nectarines, fine; Pond's Seedling and Jefferson Plums, Bon Chrétien and St. Germain Pears, fine Worcester Pearmain, and Peasgood's Nonesuch Apples, Cherries, and Apricots; second Mr. Day, Galloway House, Garliestown, and third Mr. Dow, Newbyth, Prestonkirk.

For a collection of twelve dishes, grown in an orchard house, not more than two dishes (distinct varieties) of each kind, Grapes excluded (seven entries).—First Mr. D. Melville, Elliston House, St. Boswells, the fruit being excellent. The sorts were Albatross and Princess of Wales Peaches, Pitmaston Duchess and Beurré Diel Pears, Washington and Melon Apples, Nectarines Lord Napier and Pine Apple, fine Apricots and Plums being the other dishes; Mr. McIndoe second and Mr. Williamson, gardener to J. H. Rigg, Esq., Tarvet, third. It is only just to say, however, that Mr. W. H. Divers, gardener to J. S. Hopwood, Esq., Stamford, staged the best collection, Souvenir du Congrès Pears, Early Crawford and Barrington Peaches, Pine Apple and Dryden Peaches being extremely good. Unfortunately, too many dishes of Plums were staged, and the collection was in consequence passed.

GRAPES.—For a collection of twelve bunches of Grapes, six black and six white. The prizes are presented by the Corporation of the City of Edinburgh. There were five entries. Mr. McKelvie staged beautiful fruit, Alnwick Seedling, Alicante, and Gros Guillaume, the black sorts, being in perfect order. Of the whites, Golden Hamburg were the finest, Raisin de Calabre and Muscat of Alexandria though good being not quite so fine. Mr. McHattie, gardener to the Marquis of Lothian, Newbattie, Dalkeith, second, Tynninghame Muscat and Madresfield Court being the finest; Lady Downe's very large, but not quite finished. Mr. Murray, gardener to the Marquis of Ailsa, Culzean Castle, Maybole, third with six large fine bunches, Muscat of Alexandria not quite ripened, Gros Maroc very fine, and Black Hamburg good. For eight bunches, at least six varieties, Mr. McKelvie was again first, having Alnwick Seedling fine, good Madresfield Court, fine Alicante, Gros Maroc, extremely well finished Muscat of Alexandria, and Golden Hamburg; Mr. Boyd was second, his Madresfield Court, Alnwick Seedling, and Black Hamburg being good; third Mr. Murray, gardener to T. L. Learmonth, Esq., Park Hall, Falkirk, with large and good bunches not quite finished. For four bunches, distinct varieties, there were seven entries. Here Mr. Kirk, gardener to J. T. Paton, Esq., Ailsa, was first with Alnwick Seedling, Cooper's Black, Duke of Buccleuch, and Madresfield Court, good as to bunch, and with large berries; Mr. Boyd second with better finished Grapes, and fine; third Mr. Murray, Parkhall.

For two bunches Muscat of Alexandria, two entries, Mr. McKelvie was first

with two perfectly finished examples; Mr. Day, Garliestown, second. For two bunches Black Hamburg, seven entries, Mr. Murray, Parkhall, was first with jet black bunches, rather crushed through under thinning; Mr. Boyd, second, with smaller compact bunches. With one bunch of Muscat Alexandria, Mr. John Caldwell, gardener to J. Scott, Esq., Langholm, was first with a large but rather green example; Mr. Murray, Parkhall, second, with a better finished bunch. For one bunch of Black Hamburg, Mr. Collins, Walkerburn, was first with a large berried good bunch. For one bunch of Alicante, Mr. Potter, Whitehill, Carlisle, was first with a fair example; and Mr. Caldwell second. For one bunch of Alnwick Seedling, Mr. Murray, Maybole, was first with a good example; and Mr. McKelvie second with a smaller but better finished bunch. For one bunch of Gros Colman, Mr. McKelvie took first place with a small but admirably finished bunch; Mr. Potter, second. Mr. Boyd was first for one bunch of Lady Downe's with a good example; Mr. McIndoe, second. For the best bunch of any black Grape not named in the schedule, Mr. Boyd was first with a fine Muscat Hamburg; a fine underthinned bunch of Gros Maroc securing second for Mr. Murray, Parkhall. For the best bunch of any white Grape not named in the schedule, Mr. Potter, Carlisle, led with a fine bunch of Buckland Sweet-water; Mr. Kirk, Alloa, second, with Duke of Buccleuch. The finest flavoured bunch of black was a shrivelled Muscat Hamburg, and the finest flavoured white, Duchess of Buccleuch. The finest bloomed bunch was Alicante from Mr. Forbes; Mr. McKelvie, second, with Gros Maroc.

There was a good display of Pine Apples shown. For one Queen Pine Apple the first prize was awarded to Mr. McIntyre, The Glen, Innerleithen, Mr. Ramsay, Fordell, Inverkeithing, being second. Mr. Ramsay was first for one Smooth Cayenne Pine Apple, and Mr. McIndoe second; and for two Pine Apples Mr. Ramsay was again first and Mr. McIntyre second. Mr. D. Melville had the best green-fleshed Melon, and Mr. A. Bremner, Ormiston Hall, Tranent, had the best scarlet-fleshed. Fine Figs were staged by Mr. Morrison, Archerfield, Drem, and secured the first prize. The best Peaches came from Mr. McKinnon, Melville Castle, and the best Nectarines from Mr. G. Dewar, Fife, the fruits in these classes being fine, ripe, and highly coloured.

There was a large exhibition of Pears, most of which were, however, quite green. For a collection of dessert Pears, six varieties, Mr. Dow, Newbyth, was first, and Mr. McLeod, Harvieston Castle, second, all unripe; Mr. Murray, Maybole, first for six Pears, two varieties. The Society this year offered a series of prizes for certain sorts of Apples and Pears named at the Congress held two years ago, as the most popular sorts. Many of these were late varieties, and, as a matter of course, were green and unripe; Jargonelle and Williams' Bon Chrétien were the only two ripe Pears shown, though the Apples were more numerous in a condition of ripeness. Very good dishes of Irish Peach, Tborle, and Oslin Pippins, Keswick Codlin, Lord Suffield, Ecklinville Seedling, Warner's King, Alfriston, Tower of Glamis, and Hawthornden were staged. For any cooking Apple Peasgood's Nonesuch was the best, Maiden's Blush was also very pretty. The prize for the best of any dessert Apple was awarded to Duchess of Oldenburg, though good examples of Golden Reinette, Summer Strawberry, Early Harvest, and Red Astrachan were shown in fine condition. The best two dessert Apples were Irish Peach and early Julien out of a large class. For a collection of Apples, twelve varieties, there were seventeen entries, Mr. King, gardener to Lord Hamilton, Dalzell, first, a dish of Stirling Castle being the only variety, extra fine; Mr. Bruntton, Gilmerton, was second with a much more even and, as we thought, a finer collection. There was also a numerous show of Plums, Currants, and other small fruits.

#### PLANTS.

In this section there was nothing out of the common. As usual Mr. Patterson, Millbank, was the most successful with flowering stove and greenhouse plants; Mr. Grossart, gardener to J. Buchanan, Esq., Oswald Road, also being a very successful exhibitor. For a table of plants, 20 feet by 5 feet, for effect, Mr. Grossart set up a very pretty arrangement. There was a very fresh table of Ferns, some good Cockscombs, a few Orchids, good Tuberos Begonias, and Fuchsias, Lilliums, &c., were fairly well represented.

#### CUT FLOWERS.

These were fairly numerous and of good quality. Gladiolus were very well represented, Dahlias, Roses and Asters being well shown and in good numbers. For twelve Gladioli, distinct varieties, Mr. Smith, Prestwick, was first with even spikes of Aramis, Phoenix, Phidias, Eugène Souchet, Caméleon, Crépuscule, Bicolore, Atlas, Tamerlane, Dalia, Leviathan, and Grand Rouge. Mr. Brotherston was second, Dalia, Le Vesuve, Teresita, and Caprice the best. Mr. Taylor, Inveresk, third; and six Gladioli, Mr. Hall, Kelso, first, and Mr. Henderson, Galalan, Kelso, second, with larger though not so fresh spikes. With five spikes Hollyhocks, distinct, Mr. D. McFarlane, King Meadows, Peebles, first, showing Czar, F. G. Dougal, Queen of Yellows, Purple Prince, and Agnes Berry. Mr. Robertson, Jedburgh, was second. The same exhibitors occupied the same positions for twelve Hollyhock blooms. With twelve Dahlia blooms, show, Mr. Pearson, Beechwood, Corstorphine, first, in a large class with good blooms, and Mr. Bennet, Hanley Lodge, second. For twelve fancy Dahlia blooms, Mr. Pearson was again first with a very fine dozen. The same exhibitor had also first for twelve bunches, single. For twenty-four Roses the first went to Mr. Walker, Clarendon Lodge, Linlithgow, with small but clean buds. Mr. G. T. Hunter, Lauriston Castle, in the class for twelve Roses, took first. For twelve Tea Roses Mr. Parlano, Roslea Castle, was first with bright clean blooms. Mr. McLeod, Stirling, had first for cut trusses of stove and greenhouse plants.

#### VEGETABLES (OPEN TO ALL).

As already stated, these were a very large show, and generally so fine that prizes were not easily taken. Cauliflowers, Lettuces, Celery, French Beans, and Cabbages were represented in great numbers, and if size was any criterion, drought would seem to have done these no harm whatever.

With a collection of vegetables, six sorts, there were fourteen entries, most of which were very fine. The first prize was secured by Mr. Harkness, Broadmeadows, Hutton, with good Autumn Giant Cauliflowers, extra fine Leeks, fresh Peas, good Tomatoes, a brace of Telegraph Cucumbers, and Village Blacksmith Potatoes. Mr. Culton, Castle Douglas, second with



what we considered a superior collection to the first, Williams' Matchless Celery being very fine, enormous Trebons Onions, fine Tomatoes, very fine Autumn Giant Cauliflowers, and extra Dr. McLean Peas. Mr. Bigham, Edgerton, Jedburgh, third, the Celery and Cauliflowers extra good; and Mr. Cairns, Bongedward, Jedburgh, was fourth, also with extra fine produce. Mr. McIndoe had the finest Tomatoes; Mr. Murray, Belmont, second. Mr. Wood, Woodside, Musselburgh, had first prize for a brace of Cucumbers; Mr. Cairns, Jedburgh, who was passed, showed the freshest and finest. Cauliflowers were very numerous and fine, Mr. Stevenson, Greenend, Liberton, having the finest. Mr. Waldie, Newstead, Bridge of Allan, in a fine Celery class took first. Mr. Bigham had the best Leeks, and Mr. Murray, Maybole, the best Onions. Mr. Bigham was also awarded first prize for a collection of twelve Potatoes.

#### NURSERYMEN'S CLASSES.

Messrs. R. Bain & Sons alone set up a table of plants, 40 feet by 10 feet, for effect. This was, however, a very bold and effective arrangement, the several plants of Crotons, Dracenas, and other things depended in for effect being in fine condition and beautifully coloured. The first prize was awarded. The same firm was also first for Palms, table plants, and Chrysanthemums; Messrs. J. Dickson & Sons having the best twelve Conifers.

For thirty Gladioli, not more than two of any variety, the first prize was secured by Messrs. Sinar & Mein, Kelso, who had L'Unique, Violet, Cameleon, Dictator, Teresita, Crépnscole, Atlas, Horace Vernet as the most conspicuous; Mr. Campbell, Gourcock, was second with more even spikes, but blooms of a lesser size; Mr. Service, Maxwellton, was third. No Hollyhocks were shown by nurserymen.

Messrs. Lamont & Sons had the best single Dahlias, Messrs. Cocker and Son, Aberdeen, taking first for twenty-four Show and for twenty-four Fancy Dahlias, the blooms being large and of fine quality; Messrs. R. B. Laird and Sons were second in each case. The last-mentioned firm was also first for twenty-four bunches of cut stove or greenhouse plants. Messrs. J. Cocker and Sons, Aberdeen, were well first for thirty-six Roses, very fine blooms of Emilie Hansburg, François Michelon, Mr. Jowitt, Earl of Pembroke, Louis Peyronny, and Alfred Colomb being conspicuously fresh; Mr. Smith, Stranraer, was a good second. The same positions were held by these firms for eighteen Roses.

Amongst the miscellaneous exhibits one of the most interesting was a table of rarities, which Mr. Lindsay sent from the Botanic Gardens. Messrs. Dicksons & Co., Waterloo Place, had a large table filled with Apples in 110 varieties grown at their Liberton Nurseries. Messrs. Methven & Sons had a very prettily arranged table of plants, in which the beauties of varieties of Liliun speciosum were most conspicuous; Messrs. Ireland & Thomson a table of good foliage plants, &c., and a group of ornamental shrubs, &c. Mr. Robertson Munro had a pretty group of Alpines and other plants, and the Scottish Mushroom Co. a fine quantity of growing Mushrooms from the Scotland Street Tunnel. Some beautiful blooms of Madame Desgranges and of Mr. George Wermig Chrysanthemums were shown from Corstorphine; and to Mr. Wilson, Bantaskin, Falkirk, a certificate was awarded for Odontoglossum Harryanum.

#### GLASGOW AND WEST OF SCOTLAND HORTICULTURAL SOCIETY.

THE autumn Show of this Society was held in St. Andrew's Halls on Wednesday, 7th inst., and was superior to former shows, particularly in the fruit and vegetable classes. The entries were more numerous than last year, and the competitions in many cases more keen. Large numbers of plants and cut flowers were tabled for exhibition only, which formed a display never equalled at any previous autumn show. Messrs. Smith and Simons, Kennishead Nurseries, had a table 24 feet by 6 feet of their most choice stove and greenhouse plants, among which were some fine specimens of Cocos Weddelliana, richly coloured Crotons, Dracenas, Pancratiums, Vallotas, and two very fine specimens of Gymnogramma gloriosa. The whole arranged with great taste and very highly commended by the Judges. The display of cut flowers by Mr. M. Campbell, nurseryman, Blantyre, was the most excellent exhibit of the kind in the Show and filled two large tables. Splendid spikes of Hollyhocks, Dahlias, show, pompon, and single, were in great number and of the highest quality. Carnation and Begonia blooms were in good variety. Their seedling Pansies Mrs. John Ellis and Miss French were very highly commended. Messrs. Samuel McGredy & Sons, nurserymen, Portadown, had a collection of Dahlias, Pompon and Cactus, very tastefully set up. Some of the best Pompons were Guiding Star (white), Thomas Moore (red), Isabel, Jessie McMillan, and Little Nigger. Among Cactus were Picta formosissima, Wm. Pearce, a fine yellow; Constance, a pure white; Nemesis, and Mrs. Hawkins, primrose. Highly commended. Messrs. Dobbie & Co., Rothesay, filled a large table with cut blooms, showing the excellence of strain of Marigolds, for which they are famed; excellent examples of Onions, Parsnips, Turnips, and Parsl y were also on this table. A splendid exhibit. Mr. M. Cuthbertson of Rothesay Public Park Nursery, had a collection of Pansies, Violas, French Marigolds, Antirrhinums, and Parsley Cuthbertson's New Gem. Highly commended. Mr. Alex. Lister, Rothesay, had a table 6 feet by 4 of Dahlias, Pansies, and Parsley. The Pansies in this collection were very fine, and were very highly commended. Mr. Wm. Montgomery, nurseryman, Cardross, had a splendid collection of Roses, cut blooms, which, considering the time of year, were of very good quality; a very interesting exhibit. Mr. Peter McKenzie, florist, 65, St. Vincent Street, had five hand bouquets of large size made up with choice Roses, Stephanotis, Lapagerias (white), Orchids, &c., very tastefully arranged. This exhibit was deservedly admired, and was awarded the highest commendation. Messrs. Wm. Thomson & Sons, nurserymen, Clovenfords, had a large basket of Duke of Buccleuch Grapes, berries very large. Onions over 6 inches in diameter were also shown, which had been grown with their manual preparation. An excellent exhibit and very highly commended. Messrs. W. & F. D. McMally, Glenluce and Springburn, exhibited observatory hives showing bees at work, a source of much interest to the visitors, and some splendid comb in design of "God Save the Queen," &c. Highly commended.

CLASS OPEN TO NURSERYMEN ONLY.—Twelve plants for table decoration.—Mr. John Sutherland, Lenzie, was an easy first, Mr. Peter McKenzie second. Twenty-four Gladioli, Messrs. Sam. McGredy had first with the

most superb spikes ever tabled in Glasgow. The spikes in this stand were arranged in a most beautiful manner, sloping a little to the back and relieved with the leaves of the Pampas Grass, which was very graceful and effective; with the exception of four continental varieties all were their own seedlings. Mr. A. E. Campbell, Gourcock, was second with a good stand, the blooms were smaller and arranged in the old erect style. Twenty-four blooms Dahlias, distinct varieties.—Mr. M. Campbell, Blantyre, was deservedly first with splendid blooms of Criterion, Gaiety, Illuminator, Champion Rollo, Harry Keith, Mrs. Wm. Slack, Henry Eckford, H. Watton, Salamander, Miss Cannell, Viceroy, Ethel Britton, Joseph Ashley, Buttercup, Pandora, Wm. Rawlings, Willie Garret, Muriel, Countess of Ravensworth, Thos. Hobbs, Colouist, Surprise, and Mr. Gladstone. Mr. John Sutherland was second with much smaller but very neat blooms. Twenty-four blooms Roses.—Mr. Wm. Montgomery, Cardross, was first, and Sam. McGredy and Son second, and D. Robertson, Mossend Nursery, Helensburgh, third. Mr. M. Campbell had first for collection of Carnations and Picotees, the Carnations were particularly fine. Twenty-four Pansies.—Mr. John Sutherland was first with grand blooms. Mr. A. Lister a good second, and Mr. A. Irvine third. Twelve varieties, single Dahlias, ten blooms each.—Mr. M. Campbell, was awarded first with Lutea grandiflora, Bailie Goodwin, White Perfection, Mrs. Gardener, Mrs. Kerr, John Stewart, Brilliant, Chilver Beauty, Paragon, Defiance, Delicata, Brightness—a very fine stand neatly arranged, Mr. P. McKenzie had first for hand bouquet.

CLASS OPEN TO GARDENERS AND AMATEURS ONLY.—Table of plants arranged for effect, 12 feet by 6. In this class four collections were staged. Mr. George Meston, gardener, Murcia House, Pollokshields, had first place for a neat and effective group, some finely flowered Pancratiums, Vallotas, two well bloomed plants of Odontoglossum grande, a beautiful Cocos Weddelliana in the centre of the table of a size that harmonised well with the other plants which were so admirably arranged around it. This table was certainly the best of its kind that has yet been shown. The second prize went to Mr. Alex. Raeside, gardener, Yorkhill. The ground of Maiden-hair Ferns in this group was its best feature. The central plant, a Cocos Weddelliana, too, was too large for this size of table, while the Dracenas were rather stiff and dull looking. Third prize was awarded to Mr. Jno. Mathieson, gardener, Westbank, Partick, whose Crotons were highly coloured and well grown; the arrangement, however, was heavy. A large Palm in the centre was out of all proportion to the plants it overshadowed. In addition to the Society's prize a very handsome gold medal was added by J. L. Henderson, Esq., Partick, one of the most active supporters of horticulture in the West of Scotland. For four house plants Mr. Thos. Hogg had first; Mr. Jas. Hutchinson, gardener, Kerse, Lesmahagow, was second; and Mr. J. Lyon, gardener, Greenhill, Blantyre, third. Six plants for table decoration.—Mr. John McLeod, gardener, Brentham Park, Stirling, had first prize; Mr. A. Montgomery, gardener, Rozelle, Partick, second; and John Robertson, gardener, Springbank, Stirling, third. Mr. John Mathieson was easily first for three foliage plants; Mr. Jas. Thomson, gardener, Clydeview, Helensburgh, second; and Mr. A. Raeside third. For three Orchids there were only two competitors, Mr. John McLeod being first, Caelogyne Massangeana being his best plant, and Mr. T. Hogg was second.

For three Ericas Mr. Thos. Hogg was first, a grand plant of E. Marnockiana being conspicuous; Mr. Geo. Meston was second. Mr. Hogg gained the prize for the most meritorious plant in the Exhibition with a large and finely bloomed plant of Erica Austiniana. Mr. John Mathieson was first for a single specimen Palm, a grand plant; Mr. Andrew Smith, gardener, Wheatlands House, Bonnybridge, second; and Mr. Jas. Thomson third. For one specimen Tree Fern Mr. Robt. Mitchell, gardener, Portland House, Pollokshields, was deservedly first with the best specimen shown for a long time; Mr. Geo. Meston was second; and Mr. John Campbell, Albert Gardens, third. For four exotic Ferns Mr. Jas. Thomson was first, a splendid Golden Fern, a fine plant of Nephrolepis Duffi being the best; Mr. James Canahie, Redcliff, Partick, was second, his large plant of Polystichum venustum was prominent; Mr. J. Lyon had the third place. For four British Ferns Mr. Jas. Canahie was first with very fine plants, particularly Scolopendrium crispum, which was large and very fresh, and a large pair of Polypodium Dryopteris; Mr. John Lyon was second with much smaller plants; and Mr. John McGnater third.

FRUIT.—A collection of twelve dishes of fruit, not more than two distinct varieties of one sort.—Mr. Donald McBean, gardener, Craigends, Johnstone, was first, his Grapes, Peaches, Pears, Figs, Nectarine, Melon were all excellent; Mr. A. Crosbie, Buchanan Gardens, Drymen, was second; and Mr. Thos. Hogg, third. Collection of six dishes of fruit, not more than two distinct varieties of one sort, Pine Apples excluded.—Mr. Jas. McConachie, Cameron Gardens, Alexandria, was first, his Alicantes, Peaches, and Nectarines were very good; second place went to Mr. W. Thorburn, Castle Semple Gardens, Lochwinnoch. Six dishes hardy fruit, not more than two distinct varieties of one sort.—Mr. A. Wilson, gardener, Auchencruive, Ayr, had the first place with very fine examples of Williams' Bon Chrétien Pear, Jefferson and Magnum Bonum Plums, Morello Cherries, and Royal George Peaches; Mr. Wm. Low, Viewforth Gardens, Stirling, was second; and Thos. Hogg third.

Two bunches Black Hamburg Grapes.—Mr. James Thomson, gardener, Broomhill, Partick, was first with very good bunches; Mr. A. McKenzie, gardener, Merchiston, Johnstone, second; and Mr. D. Howie, Dunamara, Culross, third. Two bunches black Grapes other than Black Hamburg.—Mr. Donald McBean was first with superbly finished bunches of Alicante; Mr. John Cadzow, Crossford, Lanark, second; and Mr. D. Murray, Culzean Gardens, Maybole, third. With two bunches White Muscat Grapes, Mr. A. Crosbie was first; A. Smith second; and Mr. John McLeod third. For two bunches of white Grapes other than Muscat, first Mr. R. Barrie, gardener, Woodstone, Row; second Mr. Jas. Cocker, gardener, Stranraer; third Mr. D. Waddell, Southpark, Bute. Six distinct varieties, Apples, four of each.—Mr. A. Crosbie was first; Mr. A. Wilson second; and Mr. R. Strathdee, Torbolton, third. The first prize for six Peaches was gained by Mr. D. McBean; Mr. Jno. McLeod was second; and Mr. John Robertson third. One Melon.—Mr. D. Waddell first; Mr. F. Stewart, Bellcairn Gardens, Cove, second; and Mr. Wm. Halliday, gardener, Cordale House, Dumbarton, third. For six Nectarines Messrs. A. Crosbie first; D. McBean second; and John Robertson third. For twelve Plums at least three distinct varieties, first Mr. G. Gordon, Drymeu; second Mr. A. Wilson; and third Mr.

Thos. Hogg. Twelve Pears at least, three distinct varieties.—Mr. A. Wilson was first; Mr. Jas. Alexander, Clydevale, Lanark, second; and Mr. R. Strathdee, third. Twelve baking Apples, at least three distinct varieties.—Mr. R. Strathdee was first; Mr. D. Murray, second; and Mr. W. Boswell, 12, Albert Place, Stirling, third. For twelve dessert Apples at least, three distinct varieties, Mr. R. Strathdee was first; A. Wilson second; and Mr. G. Gordon third.

CUT FLOWERS AND BOUQUETS.—In the class for twelve spikes of Gladioli, distinct varieties, Mr. Wm. Lees, sen., Muirend, Symington, was first with a superb stand; Mr. D. McBean was second, and Mr. W. Dipple, Caldwell, third. For six spikes Gladioli, distinct varieties, Mr. Peter Morris, Nelson Street, Largs, had the first place, Mr. Robt. Crawford, Calder Street, Lochwinnoch, second, and Mr. D. Kidd, Chappell House, Barrhead, third. The silver cup for twenty-four blooms Dahlias, distinct varieties, was won by Mr. Thos. Hogg with really splendid blooms; Mr. Robt. Smith, Howood, was second, and Mr. Jas. Hutchieson third. In the class for twelve blooms Show Dahlias, distinct varieties, Mr. Arch. Park, gardener, Lylestone, Cardross, was first, Mr. Thos. Hogg second, and Mr. Robt. Smith third. For twelve blooms Fancy Dahlias, distinct varieties, Mr. Alex. McKenzie had first and Mr. Thos. Hogg second. For eight varieties single Dahlias in bunches of six blooms Mr. A. Park was first, Mr. D. McBean second, and Mr. J. Mitchell third. In the class for twenty-four annuals, distinct varieties, Mr. Geo. Gray, Mowat Cottage, Lesmahagow, was first, Mr. Walter Rae, Woodville, Biggar, second, and Mr. Alex. McCallum, Cairndhu, Helensburgh, third. For twelve annuals, genera, Mr. Joseph Mullar, jnn., 17, George Street, Bonhill, was first, Mr. Walter Rae second, and Mr. Jas. Twaddell, Lealaw Muir, Lesmahagow, third.

For twelve blooms Show Pansies Mr. A. Ollar, Kilcerror, Campbelltown, had first, Mr. Robt. Stewart, Lenzie, second, and Mr. Wm. Storr, Gargaber, Lenzie, third. For twelve blooms Fancy Pansies Mr. A. Ollar was again first, and Mr. Alex. Wilkie, New Street, Kilbarchan, second. In the Viola class for twelve bunches, the veteran, Mr. J. Baxter, Daldowie, Broomhouse, was an easy first. His bunches were very neatly put up, and the blooms, though small, were very fresh; his varieties were Acme, Bullion, Duchess of Sutherland, Countess of Hop town, Blue Cloud, all of which were very fine; Max Kolh, Goldfinch, yellow ground with lilac edge; Countess of Kintore, seedling, white ground with lilac edge; John Burns, Morning Star, and York and Lancaster. (Dobbie & Co., Rothsay, are to send out Mr. Baxter's famous seedlings next spring.) Mr. J. Stewart was second and Mr. William McIntosh, 2, Firpark Terrace, Dennistown, third. A seedling in this stand was after the style of York and Lancaster, but with yellow stripes, very novel and attractive.

VEGETABLES.—Vegetables were remarkably well shown. The first prize for the collection went to Mr. Thos. Hogg, the superiority of which was very apparent; Mr. D. McBean was second and Mr. Wm. Low third. Mr. Donald McBean was very successful, gaining first prizes for Celery, Leeks, Tomatoes, Cucumbers, Savoys, Beans, Turnips, and French Beans. Mr. Hewett, Maryhill, had the best Carrots and Parsley; Mr. John Gentleman, West Craigmarrie, Armadale, had the best Potatoes. Cauliflowers were splendidly shown by Mr. Stewart, Woodlee, Lenzie. Onions were well shown by Mr. W. Low, his variety being Cranston's Excelstor. Mr. Wm. Hamilton had very fine Parsnips, some of them measuring 26 inches in length and 4 inches in diameter. Mr. B. Faichney had the best early Cabbage, and Mr. T. Mills the best red Cabbage, Mr. R. Strathdee the best Peas.

The plants, cut flowers, and vegetables brought forward by amateurs were very creditable to them and added much to the interest of the Exhibition. The arrangements of the Show were as usual superintended by Mr. Franc. Gibb Dougall, the esteemed Secretary of the Society, and were extremely satisfactory.—G. R.

#### BATH SHOW.—SEPTEMBER 7TH AND 8TH.

This may truthfully be described as one of the best all-round displays that has ever been held in the western counties, and certainly superior to any previous autumn exhibitions in Bath. Everything in season was well represented, and in every instance the competition was most close and good. As usual in such cases disappointed exhibitors were numerous, not a few being under the impression the Judges were scarcely "up to their work," which it is almost needless to add was only a grumble, and nothing more. The weather on the opening day was not altogether favourable, but it was much better on the second day, and the attendance of visitors was very large accordingly.

PLANT CLASSES.—Fuchsias are always grandly shown at this meeting, but they were scarcely so good as usual. The best nine plants were shown by the veteran grower and raiser, Mr. James Lye, gardener to the Hon. Mrs. Haye, Lavington, who had grand pyramids of Annie Earle, H. Brooks, Lye's Rival, Hon. Mrs. Haye, Final, Benjamin Pearson, James Welch, Lye's Favourite, and Harriet Lye. Mr. G. Snell, gardener to Mrs. Counsel, Bath, was a creditable second, his collection including handsome plants of Arabella, Elegans, and Lye's Favourite. The third prize was awarded to Mr. G. Tucker, gardener to Major Clarke, Trowbridge. For six Fuchsias Mr. J. Ruddick, gardener to Mrs. Pinder, Weston, was well first, having capitally flowered specimens of Mrs. Bright, Charming, Victoria, Bountiful, Thomas King, and Arabella. Mr. A. W. Southard was second; and Mr. W. C. Drummond, Bath, third. In the class for one dark variety Mr. J. Tucker was first for a good pyramid of Charming, and in the corresponding class for a light variety Mr. J. Ruddick was first for a fairly good specimen of Lye's Favourite. A second prize was awarded to Mr. C. Fletcher, gardener to C. H. Gabriel, Esq., Bath, for four Fuchsias.

Stove and greenhouse flowering plants were fairly well shown, though many of the specimens apparently had already done good service elsewhere. Mr. J. Cypher, Cheltenham, was placed first for twelve specimens, these consisting of Allamanda nobilis, Lapageria alba, Ixora salicifolia, Bougainvillea glabra, Clerodendron Balfourianum, Erica Marnockiana, Ixora Duffi, Allamanda Hendersoni, Allamanda grandiflora, Vallota purpurea, Statico profusa, and Pancratium elegans, the latter having seven immense spikes of bloom, while all the plants were well flowered and fairly fresh. Mr. W. Finch, gardener to J. Marriott, Esq., Coventry, was a close second; some of his plants, however, were rather stale, and others scarcely advanced enough. Among them was a large Lapageria alba and a fine

Lapageria rosea, Ixora amabilis and Allamanda Hendersoni also being very good. Mr. G. Tucker was a creditable third. The prizewinners with three flowering plants were Messrs. A. Hawkins, gardener to T. Jolly, Esq.; W. Marchant, gardener to Jerome Merchant, Esq., Bath; and W. C. Drummond. With a single specimen Messrs. W. Finch and J. Cypher, and Heathes, Messrs. J. Cypher and W. C. Drummond, in the order given in each instance. Only two collections of six Orchids were shown. Mr. Cypher was easily first, having Saccolabium Blumei major with five grand spikes; Cattleya Gaskelliana, with fourteen large blooms; Vanda snavis; Cattleya Dowiana; Odontoglossum grande, bearing eight fine spikes; and Aerides Rohanneanum with three spikes of bloom. Mr. T. Perry, gardener to H. Cruger Miles, Esq., Bristol, was second. Tuberos Begonias were remarkably fine and attracted much more notice than usual. With six plants, Mr. W. Gingell, gardener to W. Clifford, Esq., was well first, having such fine doubles as Marquis of Stafford, Gertrude, Madame Arnould, Goliath, and Lady Lennox; and the single flowering Lord Salisbury exceptionally good. Mr. M. Cole, gardener to S. Tredwell, Esq., was a close second, and certificates of merit were also awarded to Mr. M. Cole. Messrs. W. Mattick, gardener to J. Foley, Esq., Limpley Stoke, and J. Weston, gardener to the Rev. C. C. Layard, were respectively first and second for Cockscombs; while Messrs. C. Richman, gardener to G. Palmer, Esq., Trowbridge, G. Tucker, and A. Hawkins were the prizewinners with Gloxinias, a fine lot of plants being shown. Mr. G. Tucker was well first for Zonal Pelargoniums, and other successful exhibitors of these were Messrs. A. W. Southard, H. Jones, gardener to General Doherty, and M. Cole.

Fine-foilage plants were extensively and well shown in the several classes provided for them. Mr. J. Cypher took the lead with twelve plants, among these being Croton angustifolius, Cordyline indivisa, Kentia Fosteriana, Croton Johannis, Croton Queen Victoria, and Kentia australis in good condition. Mr. W. Finch was second, his Crotons and Palms being also in good health. Mr. W. Dobson, Bristol, was a creditable third. In the class for eight varieties Mr. W. Rye, gardener to J. Derham, Esq., was well first, his group including handsome specimens of Croton Queen Victoria, Areca sapida, Cycas revoluta, and Croton majestics. Mr. W. J. Mould, gardener to E. E. Bryant, Esq., was second, and Mr. H. Jones third. Several excellent groups of fifteen varieties of Ferns were staged. Mr. G. Tucker was first, his group of even and well grown plants including several good Adiantums, Gymnogrammas, and Davallias. Mr. J. Cooke, gardener to A. P. Stancombe, Esq., Trowbridge, was a very close second, his group being rich in Tree Ferns and Adiantums. Mr. J. Riddick, gardener to Mrs. Doherty, was a good third. The prizewinners with nine varieties were Messrs. T. Truckle, gardener to T. Carr, Esq.; W. Marchant and W. C. Drummond, all staging creditably.

CUT FLOWERS.—The display of Gladioli was, as far as numbers were concerned, about equal to what are usually seen at Bath, but it is doubtful if such a grand lot of spikes as those shown in the class for thirty-six varieties by Messrs. Burrell & Co., Cambridge, have been seen before, famous as the West of England is for this class of flowers. Particularly good were such sorts as Cantab, Grand Rouge, Mabel, Cygne seedling (certificated), Psyche, Mons. Adolphe Brongniart, Hesperide, Cervantes, Mirabel, Flamboyant, Chameleon, Jupiter, and Carnation. They were awarded the first prize, the second going to Mr. G. S. Walters, Came, and the third to Mr. A. A. Walters, Bath, these exhibitors also have creditable exhibits. Mr. J. Mattock was well first for twelve varieties. Dahlias were very abundant and good, the display of singles being especially attractive. The best thirty-six Dahlias were shown by Messrs. Keynes, Williams & Co., Salisbury, who had a fine even lot, included among which were Victor, Royal Queen, Henry Walton, Impera, W. Rawlings, Gloire de Lyon, Colonel, Mr. Glasscock, Eclipse, Mrs. Lungtry, J. Stanish, Prince of Denmark, Harry Keith, Thomas Hobbs, Mrs. Gladstone, Philip Laid, J. Standish, James Vick, and Statesman. Messrs. Heath & Son were a good second. With twelve varieties Mr. G. Humphries, Chippenham, was first, his stand comprising grand blooms of J. Ashby, Miss Cannell, J. Stephens, Earl of Ravensworth, W. Rawlings, J. Wyatt, Picotee, Mrs. Gladstone, Vice-President, G. Barnes, Statesman, H. W. Ward, and J. Stephens. Mr. H. Bush, Swanswick, was second, and Mr. S. Tottle third. Messrs. Keynes, Williams and Co., were first for twelve Fancies, and Mr. G. Humphries second, such sorts as Pelican, Egyptian Prince, Gaiety, Mrs. Saunders, and Peacock being very fine. The best twelve bunches of single Dahlias were shown by J. Cneal & Sons, Cratley, who had Paragon, Primrose, Negress Formosa, Duchess of Westminster, Hugo, and other good sorts beautifully set up. Mr. T. Truckle, gardener to T. Carr, Esq., was second, and Mr. A. A. Walters third. The competition with Roses was better than might reasonably have been anticipated, the local growers being well to the front. The best thirty-six blooms were shown by Mr. G. Campbell, gardener to Dr. Budd, Bath, these including fresh and good trusses of Harrison Weir, A. K. Williams, La France, Baron Hausmann, Marie Van Houtte, E. Y. Teas, C. Lefebvre, Francis Michelon, Alfred Colomb, Duke of Wellington, and Duchess of Bedford. Messrs G. Cooling & Son, Bath, were placed second, and Mr. J. Mattock, Oxford, third, both having fairly good blooms. Mr. Campbell was also first for twenty-four blooms, Mr. J. Mattock taking the second prize, and Messrs. Cooling & Son the third. Zonal Pelargoniums were very fine; Mr. M. Cole was first, Messrs. Cooling & Son second, and Mr. J. Mattock third. The prizes for Verbenas were awarded to Messrs. Mattock, Cooling & Son, and A. Hawkins in the order named. There was an exceptionally grand display of Asters of so ts. Very fine were the twenty-four French Asters staged by Messrs. Cooling & Son, and awarded the first prize, and the exhibits of Mr. T. Every was only slightly inferior. Mr. G. S. Walters was well first for German varieties, and Mr. W. J. Jones a good second. Vases of wild and choice flowers were very tastefully arranged; with the former Mr. F. Cole, Bristol, was first, Miss G. O. Heard second, and Mr. E. T. Hill third. Mr. J. Cypher was first for the vase of choice flowers, Miss Darbin being a good second, and Mr. E. T. Hill third. The best bouquet was set up by Mr. C. Winston, Clifton, Mr. M. Hoskins being second for a fine bouquet only slightly inferior, and Mr. W. C. Drummond third. Eight lots of twenty-four varieties of choice flowers were staged; Mr. G. Howe, gardener to Lewis Fry, Esq., M.P., was first, Mr. W. Iggulden, Frome, a very close second, and Mr. Perry third.

FRUIT.—One whole tent was wholly devoted to fruit, of which there was



an exceptionally grand display; Mr. J. H. Goodacre, Elvaston Castle, Derby, was awarded the first prize for a collection of eight dishes, these consisting of good Madresfield Court and fairly good Muscat of Alexandria Grapes, a good Melon, Negro Largo Figs, Rivers' Orange Nectarine, Sea Eagle Peach, Moorpark Apricot, and Kirk's Plum. Mr. W. Nash, gardener to the Duke of Beaufort, Badminton, was a close second, his Muscat of Alexandria Grapes spoiling his chance for first place; the third prize was awarded to Mr. A. Miller, Rood Ashton, Trowbridge, this collection including a good fruit of the handsome and distinct Melon, Rood Ashton Seedling.

The greatest interest was centred in the class for eight bunches of Grapes in four varieties. There were eight entries, but Mr. W. Taylor, gardener to Alderman Chaffin, Bath, was well first, being considerably ahead of all other competitors. He had very handsome bunches of Muscat of Alexandria, large but not well finished Madresfield Court, and perfect bunches of Alicante and Alnwick Seedling. The second prize was awarded to Mr. G. F. Crocker, gardener to W. H. Miles, Esq., Bristol, the principal merit of this collection being its fitness for the table. Mr. W. Nash was third, but there were two other better collections shown. The Judges, if consistent, would have awarded the first prize in the any black class other than Hamburgs to creditable bunches of Madresfield Court, instead of which Alicantes were favoured. Mr. Nash was first; Mr. T. Osman, gardener to J. L. Baker, Esq., Chertsey, second; and Mr. A. Young, gardener to B. Thomas, Esq., Clifton, third. With Black Hamburgs Mr. Nash was first, staging quite small bunches, berries also small, but well coloured. Mr. Ellicott, gardener to H. W. Tugwell, Esq., Bath, was second, and Mr. W. Iggulden third, both having rather over-ripe examples. Mr. Taylor was first with Muscat of Alexandria, none of the other exhibits approaching his in any way. Mr. W. Coates, gardener to Mrs. Miller, Westbury-on-Trym, was second, and Mr. Crocker third. In the any other white class Mr. Crocker was first with well-ripened Buckland Sweetwater, Mr. Rye being second with Golden Champion, and Mr. E. Troiman, gardener to J. Colman, Esq., Clifton, third. The successful exhibitors in the local classes were Messrs. E. Peacock, H. Jones, and E. Chedzey. Mr. W. Iggulden staged a large, compact, and well-finished bunch of Gros Guillaume, which weighed 7 lbs. 12 ozs. Numbers of Melons were shown, but none were of great merit. Mr. Nash was first in the green-flesh class with Sutton's Perfection, Mr. R. T. B. Kerslake second, and Mr. W. Iggulden third. Mr. Goodacre was first in the scarlet-flesh class with Read's Hybrid, Mr. W. Every being second, and Mr. W. Marchant third. Peaches and Nectarines were judged by flavour, to the no small disgust of the exhibitors staging the finest dishes. The first prize for nine fruits was awarded to Mr. W. Fidler, gardener to Baron C. De Tuyl, Cipping Sodbury, for a good dish of Walburton Admirable, Mr. J. Wotton being second, and Mr. Marchant third. With a smaller dish Messrs. W. Mattick, H. Dutton, and H. Lewis were the prizewinners in the order named. Mr. Marchant was first for nine Nectarines, Mr. Wotton second, and Mr. Pym third, the latter having a fine dish of Pine Apple, and which ought to have been first. Other successful exhibitors of Nectarines were Messrs. W. Haskell, R. J. Wotton, and J. Weston; of Plums, Messrs. J. Truebody, Haskell, J. Sborn, H. J. Sborn, J. Ricketts, and A. Hunt. Mr. W. Rye had the best collection of Pears. Mr. W. H. Bannister, gardener to H. St. Vincent Ames, Esq., being a good second. The last named was well first for three dishes of dessert Apples, these consisting of Red Astrachan, Worcester Pearmain, and Ribston Pippin. Mr. J. Garraway was second, and Mr. H. Dutton third. In the corresponding class for culinary sorts Mr. A. Miller was a good first, having fine dishes of Stirling Castle, Hawthornden, and Rood Ashton Seedling, the latter being a distinct and good late sort.

**VEGETABLES.**—These were surprisingly good, notably those from Dorsetshire. Messrs. Sutton & Sons, Reading, offered prizes for six varieties, and of these there were ten lots shown. Mr. J. H. Copp, gardener to W. E. Sawbridge, Esq., Shroton, was first, having grand dishes of Giant White Celery, Rousham Park Onion, Autumn Giant Cauliflower, Reading Russet Potato, Perfection Tomatoes, and New Intermediate Carrots. Mr. S. Wilkins, gardener to Lady Theodore Guest, Blandford, was a very close second, and Mr. J. Weston third. In another similar class the prizes were provided by Messrs. Webb & Sons, Stourbridge, and these also attracted a large quantity of fine vegetables. Mr. G. Garraway, Bath, was placed first, but Mr. J. H. Copp, who followed, had certainly much the best collection, the third prize going to Mr. Wilkins, who also had a fine collection. The Tomatoes were both numerous and good. Mr. J. Fortt was first with a very fine dish of Hathaway's Excelsior, Mr. Crocker second, and Mr. J. Gibson, gardener to the Earl Cowley, third.

**NON-COMPETITIVE EXHIBITS.**—Messrs. Cheal & Son, Crawley, had a grand display of single Dahlias, as also had Mr. Ware of the Hale Farm Nurseries, Tottenham, certificates of merit being awarded to both exhibitors. Messrs. Cooling & Sons had several stands of Dahlias, Roses, and other cut flowers, which were duly recognised by the Judges. Mr. R. Owen, Maidenhead, sent boxes of cut blooms of Tuberos Begonias, the strains of both single and double varieties being excellent. A certificate of merit was awarded; this favourite method of rewarding exhibitors being fully appreciated by the recipients, several other exhibitors receiving them by way of an extra prize.

### ADIANTUM LEGRANDI.

By the appearance of the above Fern we should say that there is a bright future before it, especially for working into sprays for ladies. It appears to be a dense form of *A. gracillimum*. It was exhibited in good condition at the late Shrewsbury Show on the stand of Messrs. F. & A. Dickson of Chester.—A. Y.

[This is one of the most prominent varieties of the whole section of dwarf-habited Maidenhair Ferns of the *A. cuneatum* type, and which comprise such lovely and useful Ferns as *A. Pacotti*, *mundulum*, and *excisum nanum*. It differs from all the above named by its fronds being more finely divided and pinkish in their young stage, whereas those of the others are green at all times, and their pinnules taken separately much resemble those of the species from which they spring. The fronds of *A. Legrandi*, with the exception of the size, have much

more the appearance of those of *A. gracillimum*, but are shorter, much more dense, though equally finely divided. They are excellent for buttonhole making, as their size is such as to enable anyone to use them as a whole instead of taking them to pieces as is frequently the case with *A. cuneatum*. *A. Legrandi* was raised by Messrs. Wallem & Legrand, a firm of Ghent nurserymen who succeeded Mr. Stelzner, who for years previously had made Ferns a speciality. It reproduces itself freely and very true from spores. On account of its dwarf habit this variety should not be grown in pots larger than 48's, and it is when in a large 60 or 54 that it shows itself to advantage. It thrives well under the treatment given to *A. cuneatum*.]

### ROYAL HORTICULTURAL SOCIETY.

SEPTEMBER 13TH.

THE exhibits at this meeting were varied and interesting, the greater portion of the Conservatory being occupied.

**FRUIT COMMITTEE.**—Present—Arthur W. Sutton, Esq. (in the chair), Messrs. Sutton, Lee, W. Paul, Warren, Miles, Crowley, Norman, Ross, Bunyard, Saltmarsh, Blackmore, and Dr. Hogg. Messrs. Hurst & Son sent a seedling Melon named Lundfield, which was passed as being unripe. W. Roupell, Esq., Harvey Lodge, Roupell Park, sent some dishes of very fine samples of Apples consisting of Peasgood's Nonesuch, Warner's King, Cellini Queen, and Worcester Pearmain, also some excellent bunches of Grizzly Frontignan, Chasselas Primavis, and Early Auvergne Frontignan, also Clapp's Favourite Pear. A cultural commendation was awarded. Messrs. W. Paul & Son, Waltham Cross, sent a seedling Apple, which was passed. Mr. Charles Ross, The Gardens, Welford Park, Newbury, sent two seedling Apples, one of which is a highly coloured ornamental Crab, and the other a firm yellow cooking Apple, but both were passed. A seedling Apple called The Vicar was exhibited by Rev. W. Wilks, Shirley, near Croydon. It was raised in the vicarage garden seventeen years ago, and has borne a heavy crop for the last seven years. It has a delicate flesh, and is an early August fruit. It was passed. Mr. Thomas H. Mawson, The Nurseries, Windermere, sent a dish of New Cluster Tomatoes. Mr. John Oldham sent a dish of a small early black Plum, which was raised from Golden Drop, but it did not meet with the approval of the Committee.

Mr. Edwin Beckett, The Gardens, Aldenham House, Elstree, sent a seedling Cucumber, which was passed. Mr. William Crump, Madresfield Court Gardens, sent pods of a species of Dolichos, with very long pods, which were shown as those of a Kidney Bean. It was referred to the Scientific Committee. Mr. William Taylor, of Hampton Gardens, sent two well-grown Apple trees in pots, to which a vote of thanks was awarded.

Messrs. W. Paul & Son, of Waltham Cross, exhibited twelve Peach trees well laden with fruit, and forty dishes of Apples, to which a silver Banksian medal was awarded. Mr. Deverill of Banbury exhibited Onions, D. Verell's Improved Wroxtton, Rousham Park Hero, Anglo-White Spanish, Ailsa Craig and Cocoa Nut. He also exhibited a collection of French varieties of Onions, and Neal's New Runner Bean, Ne Plus Ultra, to all of which a cultural commendation was awarded.

**FLORAL COMMITTEE.**—Present—G. F. Wilson, Esq., F.R.S., in the chair, and Messrs. Shirley Hibberd, W. Wilks, W. Goldring, James Walker, H. Herbst, W. H. Lowe, G. Duffield, W. Holmes, B. Wynne, R. Dean, C. Noble, C. Pilcher, J. Dominy, T. Baines, A. J. Lendy, H. Turner, E. Hill, Amos Perry, and Dr. M. T. Masters. Messrs. H. Cannell & Sons, Swanley, were awarded a bronze Banksian medal for a most interesting collection of Cactus and bedding Dahlias, comprising some very distinct varieties. Of the Cactus type the most notable were Wm. Patrick, very large, crimson; Mrs. Hawkins, yellow; Our Leader, dark scarlet; Cochineal, rich scarlet; General Gordon, light scarlet; Lord Lyndhurst, bright red; Yellow Cactus; Prince of Wales, of the Juarez type; Lady Brassey, brilliant scarlet; and A. W. Tait, white. Of other varieties the most distinct and effective were Germania Nova, pink, with cut and pointed florets; Lady E. Dyke, bright yellow; Picta formosissima, scarlet and yellow stripes; Fascination, pink, tipped white; Prince Alexander, orange and scarlet streaked; Wm. T. Aberly, semi-double, the florets margined bright scarlet, white in the centre; and Charming Bride, white, tipped deep red, very distinct. Messrs. Cannell & Sons also had some seedling Begonias, the result of a cross between a tuberous variety and *B. semperflorens gigantea alba*, in which the female flowers were the largest. Mr. C. Turner, Slough, exhibited seven new show Dahlias and one fancy variety, Dorotby, bronze, with scarlet streaks. The others were Glow-worm, scarlet; Purple Prince, rich purple; Malcolm, light scarlet, very large; Lustrous, rich scarlet; Royalty, yellow; Diadem (Fellows), maroon, neat form; and Olivia (Fellows), puce, a neat pretty flower. T. W. Girdlestone, Esq., Sunningdale, Berks, sent a stand of single Dahlias, very graceful and effective, Sunningdale Yellow, Snowflake, and Monte Christo being the best. Mr. T. S. Ware, Tottenham, showed a collection of Cactus Dahlias, comprising some handsome varieties, such as King of the Cactus, scarlet; Henry Patrick, pure white; Zulu, intense maroon; William Darvil, crimson; William Rayner, a peculiar reddish salmon tint; Empress of India, dark maroon; Mrs. Hawkins, yellow, Juarez; William Pearce, yellow; and Cochineal, scarlet. There were several stands of single and Pompon varieties of Dahlias, including a selection of choice varieties. A group of hardy flowers also came from Tottenham, including some fine Gaillardias and varieties of *Lilium speciosum*, the white Kratzeri and the dark M. Ipomene being very notable. A vote of thanks was awarded for Campanula isopbylla alba, with pure white flowers, and a bronze medal for the collection of flowers. Mr. R. Dean, Ealing, showed flowers of *Chrysanthemum lacustre maximum*, a dark Gaillardia, and a dwarf free yellow French Marigold.

A vote of thanks was accorded to B. D. Knox, Esq., Caversham, Reading (gardener, Mr. Lawrence), for plants of *Aerides Rohanianum* with two long racemes; *Cypripedium Harrisianum*, twelve flowers; and *Oncidium lanceanum* var. *Louvrexianum*, a dark coloured variety. Dr. Duke, The Glen, Lewisisham, sent a plant of *Cattleya Dukeana*, supposed to be a natural hybrid. F. G. Tautz, Esq., Studley House, Hammersmith, exhibited a plant of *Dendrobium superbiens* with two strong growths 2 feet 6 and 2 feet 9 inches in length, the former bearing a raceme of seventeen flowers. A cultural commendation was awarded. A vote of thanks was also awarded



for *Aerides Rohanianum* with a raceme 18 inches long. N. C. Cookson, Esq., Oakwood, Wylam-on-Tyne (gardener, Mr. Murray), was awarded a vote of thanks for *Cypripedium Io*, which is distinguished by its broad petals, with heavy dark spots. In addition to the *Odontoglossum* certificated Baron Schröder had a plant of *Saccolabium cœleste*, with spikes of pale blue flowers.

Messrs. J. Veitch & Sons, Chelsea, sent several new and interesting plants, including *Rhododendron Aphrodite*, delicate blush, *Crinum Hildebrandti*, with broad white recurving petals and red stamens, *Impatiens Sultani variegata*, and *Nepenthes cylindrica*, bearing a great number of pitchers. A silver Banksian medal was awarded to E. H. Watts, Esq., Devonhurst, Chiswick (gardener, Mr. A. Wright), for eight conical specimen *Selaginellas*, about 3 feet high. From the Society's gardens, Chiswick, came a group of *Begonias* of the *semperflorens* varieties, *Carrieri*, *Bruanti*, *Saundersi*, *Smithi*, and the small-leaved *validissima* and *Richardsi*, also a collection of *Aster* blooms of numerous varieties, and some handsome flowers of *Crinum Moorei*. Mr. R. H. Munday, Church Street, Basingstoke, sent a dark crimson *Coleus* sport, named Mrs. H. Munday. The same exhibitor also had a stand of decorative *Dahlias*. Mr. J. King, Rousham, Aylesbury, exhibited two double *Zonal Pelargoniums*, named W. K. Gurney and Katie Gurney, the former scarlet, and the latter salmon scarlet.

#### CERTIFICATED PLANTS.

*Odontoglossum Schroderianum* (Baron Schroder).—A scarce species from South America, introduced by Messrs. Sander & Co., St. Albans, eighteen months ago. The growth and pseudo-bulbs are suggestive of *O. hastilabium*, the flowers 2½ inches in diameter in a short raceme of three. The sepals and petals are heavily blotched and mottled with brown, tipped with greenish yellow, the lip bright crimson at the base, contracted in the middle and white at the upper part. Very distinct and effective.

*Dendrobium Stratiotes* (Sir Trevor Lawrence, Bart., M.P.).—An extremely interesting and distinct species with a short raceme of four flowers, the sepals white, the petals very narrow, greenish, twisted, and erect, the lip three-lobed, white veined with purple.

*Habenaria militaris* (Sir Trevor Lawrence, Bart., M.P.).—A terrestrial Orchid with narrow green leaves, faintly spotted white, the stem terminating in a raceme of bright scarlet flowers, the lip four-lobed, with a long spur from the base, the other portion of the flower greenish and inconspicuous.

*Masdevallia Culex* (Sir Trevor Lawrence, Bart., M.P.).—A botanical certificate was awarded for this *Masdevallia* which has minute papery flowers on hair-like stalks, and small ovate leaves.

*Schubertia grandiflora* (A. C. Bartholomew, Esq., Park House, Reading).—An *Asclepiadaceae* climber from the Argentine Republic, with elliptical hairy opposite leaves, 6 inches long by 3 inches broad. The flowers are borne in axillary umbels of seven or eight, the pedicels covered with brownish hairs, the corolla five-lobed, 3 inches in diameter, white, with a few hairs, and having a strong odour.

*Optismenus albidus* (J. Veitch & Sons, Chelsea).—A dwarf plant of the *Panicum* tribe with small whitish leaves, faintly tinged with green at the base of the stems.

*Rhododendron Thetis* (J. Veitch & Sons).—A hybrid *Rhododendron* of the greenhouse group, with large umbels of ten or twelve flowers each, the flowers of fine size and form, pure clear yellow. The plant had three fine trusses and two others showing.

*Nepenthes Curtisi* (J. Veitch & Sons).—An introduction from Borneo, with long tapering pitchers, darkly mottled with red, the "lid" mottled on the outer surface, the mouth of the pitcher broad and dark.

*Iresine Colemani* (Mr. W. Wildsmith, Heckfield Place Gardens, Winchfield).—A fine variety of the *I. Lindenii* type, but with broader longer leaves of a darker colour, the veins being lighter than the other portion of the leaf.

*Dahlia Maude Millett* (T. W. Girdlestone, Esq.).—A pretty single variety, neat in form, of moderate size, white at the base of the florets, rose tinted in the upper half.

*Dahlia Miss H. Henshaw* (T. S. Ware).—A single variety of an extremely pale yellow tint, very delicate. Flower of medium size, florets broad.

*Dahlia Glow-worm* (C. Turner).—A brilliant scarlet show variety of great substance and fine shape.

*Dahlia Lustrous* (C. Turner).—Very dark scarlet, excellent form, and extremely rich in colour.

*Dahlia William Carlisle* (C. Turner).—A Pompon variety, the blooms neat in form, white at the base, heavily tipped and tinged with crimson.

*Dahlia Purple Prince* (C. Turner).—An extremely large flower, rich crimson in colour, symmetrical and deep.

*Dahlia Olivia* (C. Turner).—A show variety raised by Mr. Fellowes, very neat in form, of a puce purple colour.

**SPECIAL PRIZES.**—Messrs. J. Carter & Co., Holborn, offered prizes for a dish of Carter's Perfection Tomatoes, which brought six competitors with very fine fruits. Mr. Lockie, Oakley Court Gardens, Windsor, Mr. C. J. Waite, Glenhurst Gardens, Esher, and Mr. L. Jennings, Forest Lodge, Farnboro', were the prizewinners in the order named. The prizes offered by the same firm for a dish of Jubilee Runner Beans were won by Messrs. Richardson, Bunting, and Beckett, amongst six competitors.

Messrs. Sutton & Sons, Reading, offered prizes for Early Gem Carrots, which brought twelve competitors, Mr. R. Lye, Sydmonton Court Gardens, Newbury, being first with fine even specimens. Mr. J. Baker, Bampton, was second with smaller but very even and handsome specimens, Mr. Pope, Highclere Castle Gardens, Newbury, being third. Messrs. Sutton's prizes for their Perfection Tomatoes were won by Mr. C. J. Waite with very handsome fruits. Mr. Jennings second, and third Mr. Lockie. Samples were also shown by Mr. Lockie of Sutton's Seedling Tomato, a golden yellow oval fruit in clusters, very freely produced. The specimens shown were grown out of doors.

Messrs. Webb & Sons, Stourhridge, offered prizes for a dish of Jubilee or Sensation Tomatoes. There were seven entries, Mr. J. Muir, Margam Park Gardens, being first with Sensation, very fine. Mr. W. Pope was second with Jubilee, and Mr. Waite third with Sensation.

Messrs. H. Deverill & Co., Banbury, contributed prizes for the New Runner Bean, Neal's Plus Ultra, which induced a remarkable competition, no less than nineteen entering. Mr. P. Cornish, Enfield, was first with long fine pods. Mr. Bunting was second, and Mr. G. Neal, Bampton, third. Some of the pods were 10 inches long and very even.

#### TOBACCO CULTURE IN KENT.

NOTWITHSTANDING that the experimental culture of Tobacco last year proved anything but a brilliant success, a great amount of useful knowledge has been derived from the observations then made. The season so far has not been satisfactory. The ex-Sheriff of Kent (Mr. C. de L. Faunce de Laune) has again half an acre of land at Sharsted Court, near Sittingbourne, under Tobacco cultivation; and he expresses himself sanguine that if only the Government can be induced to afford a fair opportunity of experimenting, the trials will at length prove successful. Mr. de Laune has in the main adopted a similar system of cultivation to that pursued by him last year. There are, however, one or two important points upon which he has profited by experience. The result of last year's trials tended to show that a variety of yellow Tobacco, and another known as "Big Frederick," were the most suitable to the English climate; but a number of varieties (principally American) are again being tried, including those which proved most successful, and a few entirely new kinds. The leaves of the plants raised from home-grown seed are already becoming mottled, indicating that they will soon be ready for cutting. But while these experiments are being conducted at great trouble and expense, Mr. de Laune complains that not only are those by whom they are being made exposed to a great amount of criticism on the part of those who know nothing whatever of the subject, but the Government are not affording them even reasonable facilities to carry out their trials.

American Tobacco in the leaf state is never put on the English market until eighteen months have elapsed, and then it is left for a considerable time in bond to continue maturing. Last year's English crop is now undergoing the sweating process, upon the result of which everything depends, and at this juncture the Inland Revenue authorities are calling upon experimentalists to either pay duty, have the Tobacco warehoused under bond, or have it destroyed. Inasmuch as the process of curing is not yet completed, it would not, obviously, be a fair experiment either to bond it, destroy it, or be compelled to pay duty upon an article which may ultimately prove to be worth something or nothing. Unfortunately no Government official having any knowledge of the subject, the culture and preparation of Tobacco, has yet been called upon to inspect and advise the authorities, but Mr. Faunce de Laune is shortly expecting a visit from Dr. Bell, the head of the Chemical Department at Somerset House, by whom an investigation will be made. Meanwhile every process has to be gone through in the presence of an Excise officer, supervision which must necessarily be most vexatious, not to say needless, inasmuch as it could be dispensed with by the imposition of a duty per acre.

The crop secured at Sharsted Court by Mr. de Laune last year has been treated in various ways with a view to ascertain which means of curing is best suited to the peculiarities of the English climate. Much of it has gone mouldy, but that packed in tins seems to have done well, and the colour is excellent. Taking all things into consideration, the experiment being made at Sharsted Court is progressing favourably, and when the "weed" is thoroughly cured a very fair remuneration may be expected.—(*Daily Chronicle*.)

#### NATIONAL CHRYSANTHEMUM SOCIETY.

SEPTEMBER 14TH AND 15TH.

THE early Show of this Society was held at the Royal Aquarium, Westminster, on Wednesday and Thursday, and a Floral Committee meeting was also held on the first day. The exhibits were arranged as well as possible by Mr. William Holmes, the Hon. Sec., but the Central Hall was not so convenient for the purpose as usual. There was a fair display of Chrysanthemums, but not a large competition. Such varieties as Madame Desgrange, and its golden form G. Wermig, were well represented, some of the blooms being of grand size and substance.

*Dahlias* were extensively exhibited, show, fancy, single, and pompon varieties being excellent, both in competition and from various firms.

#### CHRYSANTHEMUMS.

With a group of Chrysanthemums Messrs. Davis & Jones, Camberwell, were easily first, showing excellent plants of the leading early varieties, Madame Desgrange, Pynaert Van Geert, and Mrs. Pitcher being extremely fine, the marginal plants being dwarf specimens of the white Madame Jolivart. The plants were tastefully arranged, and the group also secured Mr. Wm. Colchester's special prize. Messrs. Davis & Jones also won the second prize with a pretty group of Pompons. In the large flowered class Mr. J. H. Witty, Highgate, was second with dwarf plants, and Mr. G. Stevens, Putney, third, his group being less well finished. For twelve plants Mr. H. Neary, gardener to Rev. R. W. Powell, Hornsey, won first honours with good specimens of Madame Desgrange and G. Wermig, one plant of the former about 3 feet in diameter being very even and compact. Messrs. Davis & Jones were second with smaller plants, but well flowered, and Mr. G. Stevens third.

A class was provided for a collection of cut Chrysanthemum blooms, number not stipulated, in which there were five entries. Mr. Kendall, Roehampton, was adjudged the first prize for fifty bunches, representing a number of varieties, the Pompons being very bright and fresh. Messrs. Davis & Jones were second with much finer blooms of thirty varieties and sixty bunches; Madame Desgrange, Flora, Mrs. J. R. Pitcher, Mrs. Cullingford, and Mons. Pynaert Van Geert were especially notable. Mr. R. Owen, Maidenhead, was third, and Mr. Witty was fourth.

Four stands of twelve blooms of Madame C. Desgrange were entered, Mr. J. Blackburn, gardener to J. Scott, jun., Esq., Elmstead Grange, Chislehurst, being first for grand blooms; Messrs. Davis & Jones were second;

and Mr. J. Doughty, Angley Park, Cranbrook, third. For twelve blooms of any other variety than Madame Desgrange, Mr. H. Elliott, Mortlake, was first with G. Wermig; Messrs. Davis & Jones were second with several good varieties; and Mr. G. Stevens third with G. Wermig. Messrs. Davis and Jones were first with twelve Pompons, a very pretty stand; they were also first for Mr. Simon Delaux's prize for six varieties of varieties sent out by that raiser. Mr. J. Blackburn was first with six bunches of Madame Desgrange, magnificent blooms; Messrs. Davis & Jones and G. Stevens following.

#### DAHLIAS.

With sixty Dahlia blooms Mr. C. Turner, Slough, won first honours for grand blooms in many varieties. Messrs. Keynes, Williams & Co., Salisbury, were second with fine substantial blooms. There was a good display in the class for forty-eight Dahlias, Mr. C. Turner again taking the lead with very handsome blooms of great size and substance. Messrs. Saltmarsh and Son, Chelmsford were good second, and Mr. J. Walker, Thame, Oxon, third. In the class for twenty-four Dahlia blooms there were seven competitors, Mr. J. Walker winning first honours, followed by Messrs. Saltmarsh & Son and Mr. G. Humphries, Kington Langley, Chippenham. Messrs. Saltmarsh & Son had the best twelve blooms, Mr. J. Walker and Mr. H. Steer, Southwood Road, New Eltham, being second and third. The single Dahlias made a pleasing and varied display. Messrs. Cheal & Son, Crawley, were first with twenty-four bunches very tastefully set up, the varieties distinct and bright. Mr. T. S. Ware was second also with a good collection. Messrs. Cheal & Sons also led with twelve bunches of single Dahlias, Messrs. J. Gilbert & Sons, Ipswich, being second. For a collection of decorative Dahlias Messrs. Keynes, Williams & Co. were first with a most effective stand, in which Juarez was conspicuous. Messrs. Cheal & Sons were second.

The finest twelve bunches of Pompon Dahlias was shown by Mr. J. Burrell, Cambridge, very neat blooms of distinct colours. Messrs. Keynes, Williams & Co. were second, and Messrs. J. Gilbert & Son third. Mr. C. Turner was first for twenty-four bunches of Pompon Dahlias, Messrs. Keynes, Williams & Co. second, and Messrs. J. Cheal & Son third, these three collections making a very attractive display.

#### MISCELLANEOUS.

Mr. T. S. Ware, Tottenham, exhibited a large collection of early flowering Chrysanthemums, representing thirty varieties. Amongst them were Madame C. Desgrange, G. Wermig, and the pale sulphur intermediate form Mrs. Burrell; Mignon, bright yellow; Fiberta, and the lighter tinted Canari; Petollant, sulphur; Mrs. J. R. Pitcher, white, large; Scarlet Gem, Précocité, yellow; M. Dufoy, purple; Blushing Bride, tinted purple, pretty; Toreador, bronze and orange; and Madame Pecoul, pale purple. Messrs. H. Cannell and Sons, Swanley, contributed a very handsome collection of Cactus bedding, Pompon and single Dahlias, tastefully set up with their own foliage. Seven boxes were staged, comprising some hundreds of blooms of most distinct and effective varieties. Six stands of show and fancy Dahlias of great merit were also shown by the same firm, and much admired. Several boxes of fine Tuberosus Begonias were also shown from Swanley.

Messrs. J. Burrell & Co., Cambridge, were awarded the first prize in the class for a magnificent collection of about 150 spikes of Gladioli, the flowers of great size and varied in colours. Mr. R. Owen, Maidenhead, sent a choice collection of Tuberosus Begonias, single and double, representing capital strains. Flowers of Ivy Pelargonium Charles Turner, a lovely double rose cerise variety of great excellence. It has been awarded five certificates this season, including that awarded by the Floral Committee at this meeting. Mr. W. Gordon, Twickenham, had a fine group of Lilies and Japanese Maples, varieties of *L. auratum*, *L. speciosum*, and *L. longiflorum*. Mr. Benjamin Field, Old Kent Road, had a stand of ornamental pots and horticultural sundries. Mr. H. G. Smyth, Goldsmith Street, Drury Lane, had a stand of horticultural sundries. Mr. Wm. Colchester, Ipswich, had a stand of their Ichthemic Guano and other artificial manures. Messrs. Wood and Son, Wood Green, also had a collection of horticultural sundries and samples of artificial manures.

#### FLORAL COMMITTEE.

Present—Mr. E. Sanderson in the chair, and Messrs. Richard Dean, C. Gibson, N. Davis, S. Gilbey, G. Gordon, Lewis Castle, J. Mardlin, G. Stevens, G. Langdon, R. Owen, T. Bevan, J. Wright, and J. P. Kendall.

Exhibits were not very numerous, but included several new Dahlias and other flowers, certificates being awarded for the following Dahlias:—Sidney Hollings (Humphries), Maude Millett (Girdlestone), Malcom, Glow-worm, and Purple Prince (Turner), Miss Roberts, Henry Patrick and Zulu (Ware), Grace, Isult, Janet, and Nellie Cramond (Keynes, Williams & Co.), Lady Emily Dyke, William T. Avery, and Mrs. Marsham (Cannell), Gladioli Rupert, Irene, and Iolanthe (Burrell), and Ivy Pelargonium Souvenir of Charles Turner (Owen).

Mr. Whibley was awarded a vote of thanks for a plant of *Eucomis punctata*, bearing a large scape of flowers. Several other plants and flowers were submitted that were not considered worthy of special award, and two or three Chrysanthemums were requested to be shown again.

exceptionally good. Carlisle Codlin, a very heavy cropping, yet but little grown sort, ought to be thinned out for present use or the markets, but the bulk of the fruit ought not to be gathered till the seeds are brown, as it will keep good much longer than either Lord Suffield, the Keswick or Springrove Codlins. Lord Suffield is one of the best for marketing, and nothing will be gained by keeping them longer; on the contrary, the fruit loses weight as it ripens. The same remarks apply to the other two Codlins. Those to be stored should not be gathered too early. They ought not to be dragged from the trees, or otherwise they soon shrivel. The old Hawthornden is unusually good this season. It is advisable to thin out for present use, the best of the fruit being gathered when fit and stored will keep good till December. Stirling Castle is plentiful and of good size, but is not a good keeper. Duchess of Oldenburg is quite good enough for dessert purposes this season, and will be available till the end of September. Manks Codlin as usual is cropping heavily. Ours keep good well into November, and is a favourite in the kitchen. The earliest dessert sorts are nearly all bad keepers. Joanneting, Early Julien, Margaret, and Early Harvest are already over, at any rate in the southern districts, and with us Irish Peach and Beauty of Bath are past their best. Both of the latter are free bearing handsome sorts, and must be eaten almost fresh from the tree. They ought really to be ready to drop before they are gathered, and at this stage they are of excellent quality. Devonshire Quarrenden is exceptionally good with us, a hot season evidently suiting this old favourite. This again we do not gather wholesale, but only as they are wanted. Gathered and stored they lose their brightness of appearance, as well as their crispness and brisk flavour. Summer Golden Pippin is a favourite dessert sort, but does not keep long, and ripens in August or early in September. Kerry Pippin, another small variety, is perhaps the most valuable of the early sorts, especially for home use. If gathered at intervals of a few days and stored on a clean dry shelf, it will be available during the whole of September and October, and it has been kept in boxes well into November.

This plan of gathering and storing Apples direct in clean boxes is a good one, and owners of small gardens are especially advised to try the experiment with both early and late sorts. In every case the fruit should part from the trees freely, the pips also be nearly or quite brown, and then if carefully stored in the boxes, no hay, paper, or other material being mixed with them, and the lids shut down, they will keep surprisingly well in a loft or other dry position. By no other means can they be kept so long and so good in every respect.

EARLY PEARS.—These generally are not nearly so plentiful as Apples, the plague of bullfinches being partly to blame for this. Early sorts, in common with the Apples, do not keep long after they are ripe, and the methods to be adopted, in order to prolong their respective seasons, are planting in various sites, and gathering and ripening the fruit at intervals of a few days. Jargonelle may safely be considered the finest early sort in cultivation, but the fruit keep badly. We have trees on south, west, and south-east aspects, and have a supply of fruit from the middle of August till the second week in September. Williams' Bon Chrétien, under much the same treatment, also gives a valuable succession of most luscious fruit. If only one or two trees are grown in the same position it is a mistake to gather all the fruit at one time, as they will nearly all ripen together, and the bulk perhaps spoil before they can be eaten. Gather a boxful as soon as the pips commence to colour, or when they will part from the tree on being lifted, and place them at once in a warm house or kitchen. This will hasten ripening, and if the process is repeated at intervals of about four days, the season will be materially prolonged, and few or no fruit spoilt. Beurré de l'Assomption is earlier than Williams' Bon Chrétien, and altogether a fine companion to it. Souvenir du Congrès resembles the Bon Chrétien, and is a fine variety; in season during September and well into October. This also should be gathered and ripened at intervals. The serviceable Beurré d'Amanlis ripens during September, but does not keep long. Both this and Beurré Superfin do well as pyramids, the latter ripening late in September, and keeping for a short time only. It is one of the most buttery Pears in cultivation. Flemish Beauty ripens rather late in September, and ought to be gathered before the seeds are brown, or the quality of the fruit will be injured. Summer Beurré d'Arcmburg and Napoleon III. are also good September Pears.

KEEPING PLUMS.—Coe's Golden Drop, if it can be preserved from wasps and birds, will hang on the trees sometimes as late as the second week in November, and this variety ought therefore to be the last gathered. Ickworth Imperatrice and Blue Imperatrice ripen in October and hang for several weeks, and after they have shrivelled are still of excellent quality. We have tried the plan of wrapping both these and Coe's Golden Drop in thin tissue paper, and packed away carefully in a box they keep surprisingly well. This method of keeping them for special purposes ought especially to be adopted where the fruit cannot otherwise be preserved from wasps and other enemies.

#### FRUIT FORCING.

MELONS.—The latest plants are now well up the trellis, having been stopped when they extended two-thirds across it or rather more. We grow all our Melons in houses on the single cordon system—i.e., the plants have all the laterals rubbed off up to the height of the trellis, and then every alternate lateral on opposite sides of the primary, stopping it when two-thirds across the trellis. The laterals show fruit blossoms at the second or third joint, if not the laterals are pinched at the second joint, relying on the sub-laterals for the show of fruit. If the plants are



#### HARDY FRUIT GARDEN.

EARLY APPLES.—These both culinary and dessert varieties are ripening fast. On light soils the fruit is rather small, and not of the best quality; but where the subsoil is of a clayey nature the Apples are



weak and there is no hurry for the fruit remove all staminate and pistillate flowers on the laterals, stopping at the second or third joint, waiting for fruit on the second or sub-laterals, which is an advisable plan where time is not a consideration, and a full crop and larger fruit are desired. We generally contrive to have both systems in the same house, which gives a longer succession of fruit—viz., plants allowed to fruit on the first laterals; those give from two to four fruits per plant, and those that fruit on the second or sub-laterals four to six fruits each, the latter being a fortnight to three weeks later. As we have to maintain a succession daily from May to November inclusive the plan is an excellent one. A rather dry condition of the atmosphere, with a little ventilation so as to insure a circulation of air, is advisable, with a bottom heat of 80° to 85°, and impregnating the blossoms after they become fully expanded is advantageous to a good set. Do not earth up the roots until after the fruits are set and swelling. Fire heat will be necessary to maintain a temperature of 70° to 75° by day artificially, rising to 80° or 85° from sun heat, losing no opportunity of closing early, so as to run up to 90° or 95°. Be sparing of the syringe, only use it for damping in the morning, and afternoon syringing the foliage only on bright days and in the early part of the afternoon. Water at the roots only when necessary, using liquid manure to assist in swelling off the crop, giving a thorough soaking where needed. Sprinkling with liquid manure all available surfaces in the afternoon we find highly beneficial to the foliage, but a better plan is to sprinkle the surface of the border with a few fresh horse droppings about twice a week, and a little soot—just a dusting—is sufficient. We go a little further—viz., give each plant a handful of dissolved bone—superphosphate of lime, but we use no manure in the soil, except some lime rubbish and charcoal refuse, if they can be termed manures.

Considerable attention is necessary with plants swelling their fruits in guarding against canker and preventing the fruits cracking. Fresh slacked lime applied on the first appearance of canker will subdue it, repeating as necessary. A lessened supply of water both at the roots and in the atmosphere, particularly the latter, is the proper remedy for cracked fruits, or cutting the shoot half way through a few joints below the fruit in the case of very vigorous plants. Fruit ripening should have a little air constantly with a temperature of 70° to 75°, and as much more as can be had from sun heat under 100°, with a corresponding increase of ventilation. Cut the fruit as soon as there is the least indication of the footstalk parting from it, even earlier than that if the fruit is expected to keep, and place it in a light and moderately airy fruit room. They will have more flavour and be more mellow than fruit allowed to bake on shelves in the sun.

Wet the foliage of plants in pits and frames as little as possible, and water only at the roots to prevent flagging. Renew or renovate the linings to finish off the crop directly the heat is found to be on the wane, and employ a covering on cold nights. In dull damp weather, and especially at night, leave a little ventilation; a little tilting of the lights at the back will allow the pent up moisture to escape, and it will be an aid to the quality of the fruit, and may prevent its cracking. Keep the foliage thin, and the fruit well raised to the light.

**CUCUMBERS.**—Keep young plants well up to the glass to insure a sturdy growth, and pinch out the growing point at the second leaf if the plants are to be trained with more than one stem. It is important whether the plants are to have one or more stems that the laterals up to the trellis be rubbed off as soon as discernible, leaving the leaves, when they may be allowed to make side shoots for bearing. Continue the preparation of fermenting materials where such is employed for bottom heat. Manure will require to be turned about every three or four days, while tan will only require to be turned once, and that as soon as it is fairly warmed through. In forming the beds whatever material is employed tread it well down. Use the syringe sparingly, giving a light syringing only in the early part of the afternoon on bright days, but moderate moisture must be secured by sprinkling in the morning every available surface, and damping before nightfall. The temperature should be maintained at 70° to 75° by artificial means, falling 5° through the night, and allowing an advance to 80°, 85°, or 90° from sun heat, closing at 80°. In pits and frames the temperature must be maintained by renovating the linings as necessary, and employ night coverings to prevent too great a diminution of temperature during the night. Water very carefully, and sprinkle the foliage only on bright days. Keep the foliage thin, removing bad leaves and exhausted growths, and husband the sun heat as much as possible by early closing.

**PEACHES AND NECTARINES.**—*Lifting Trees in Succession Houses.*—When the growth is too free, the crops not being satisfactory, the trees should be root-pruned or lifted as soon as the foliage shows indications of falling; if judiciously performed this will check their vigour and induce short-jointed fruitful wood. Any lifting or root-pruning should be performed before the leaves fall, affording a good watering afterwards, mulching with a few inches thickness of short manure, and syringing the trees each evening for a few days. The trees will soon produce young active feeders.

*Late Houses.*—Trees of those very fine varieties—Barrington, Princess of Wales, Gladstone, Sea Eagle, Lady Palmerston, Walburton Admirable, the Nectarine Peach, and Comet, will now be ripening the fruit in houses that have been freely ventilated, kept as cool as possible through the hot weather by those means, well watered at the roots through a good surface mulching, and the foliage kept clean and healthy by forcible syringings. The trees should now have the benefit of a free circulation of air, utilising sun heat by keeping the ventilators closer than usual, as with ventilation in the early part of the day the

temperature may be allowed to run up to 80° or 85°, which will do more to ripen the fruit and wood than sharp firing in dull weather. A somewhat drier condition at the roots is desirable when the fruit is ripening, but they must not be allowed to suffer from want of it so as to affect the foliage, and though the trees are not to be syringed an occasional damping will greatly tend to improve the health of the foliage. In dull, wet weather a gentle warmth in the pipes will be serviceable in securing a genial warmth and allowing of a circulation of air.

*Unhated Houses.*—Induce ripening by a somewhat dry atmosphere. Make the most of sun heat by allowing a considerable advance under its influence, closing early, but putting on a little top ventilation before night. Keep the wood thin, cutting away any gross growth, and shorten any sappy shoots to 12 or 15 inches, and keep all laterals closely pinched to one joint.

#### PLANT HOUSES.

*Hyacinths.*—A number of these should be potted at once singly in 5-inch pots, while three bulbs may be placed in each 7-inch pot. Selected bulbs or first size roots should be used for the former, or if moderately cheap varieties only are purchased, place the best of them in single pots, and the remainder two or more together. For many purposes the last method is as good as the first, and saves considerable labour both in potting, watering, the number of pots, and quantity of soil. For nearly all decorative purposes we have relied upon bulbs that can be obtained from 18s. to 25s. a hundred. For exhibition purposes these cheap varieties will not do, but for all ordinary purposes they are equally as good as those that cost three and four times the amount or more. We find that we can produce a much better effect, and have considerably more material for various purposes, than when dearer bulbs were purchased annually. Some should be potted at intervals of a month until the end of October. Good varieties that can be purchased cheaply are—Blues: Grand Lilas, Charles Dickens, Marie, and Baron Van Tuyl. Reds: Amy, Madame Hodson, Robert Steiger. Blush and pinks: Gertrude, Lord Wellington, Norma, Grandeur à Merveille, and Gigantea. Whites: Madame Van der Hoop, Alba Maxima, Alba Superbissima, Grand Vedette, and Baroness Van Tuyl. For early flowering none are so early or surpass Homerus (red), and La Tour d'Auvergne (double white), the earliest of all Hyacinths.

*Tulips.*—Early Duc Van Thols and White Pottebakker should be potted in quantity or placed thickly together in pans or boxes according to the demand. By this method good pans or pots can be made up suitable for any purpose by lifting out the plants as they come into flower. Early in the season Tulips flower irregularly, but by this method even profusely flowered pots or pans can be had. Chrysolora and Canary Bird may be treated in the same way, as both are excellent yellows for early flowering; the first is perhaps the better of the two. To succeed these Vermillon Brillant, Keizers Kroon, Proserpine, or any other variety may be potted, reserving double kinds for the latest batch to be potted the end of October or early the following month. It is usual to place three bulbs in a pot, but a much better effect is produced by placing five or six in a 5 or 6-inch pot according to the size of the bulbs individually. The bulbs of some varieties are considerably larger than those of others. Whichever size is used, if the bulbs can be placed in the pots they will contain sufficient soil to support them. All the later bulbs for flowering after the middle of February are better established in pots than grown in boxes and afterwards lifted out.

*Narcissus.*—Both the border and Polyanthus varieties should be potted in quantity. These should be placed in 6 and 7-inch pots, placing as many bulbs in each as they will accommodate. Not more than four of some kinds can be placed in each pot, while half a dozen of others may readily be placed in them, the size of the bulbs vary considerably. The border varieties may be potted until the end of October provided they are out of the ground and reserved for the purpose. If they have to be lifted this operation must not be delayed, for they commence rooting afresh almost directly the foliage dies away. All that have commenced root action must be potted at once, for to dry them afterwards will prove serious. Polyanthus varieties may be potted for succession until the end of December. Those for the last batch must be kept dry but cool, and left under ashes all winter; in fact they need never have house or frame protection. These late plants will be invaluable for yielding cut flowers towards the end of May or early in June, providing they are given a northern aspect after they are removed from the plunging material.

*Liliums.*—*L. candidum* and *L. Harrisii* can now be obtained, and should be potted without further delay. The former should be placed into 6-inch pots, and the latter into 5-inch. Both may be placed in frames until they start, but *Harrisii* should be plunged and the surface of the soil covered with cocoa-nut fibre refuse to save the necessity of watering. *L. candidum* will not be long before it commences to root and push up leaves which precede the flower stem.



#### PRACTICAL BEE-KEEPING.—No. 18.

UPON examining a stock from which a swarm has issued, capped queen cells depending from the lower



edges of the combs will commonly be found. In many instances, however, the queen cells are in a much less advanced state, and upon a sudden wave of heat taking the bees as it were by surprise, after a considerable period of cool and unfavourable weather, the bees, if strong and numerous, hastily form queen cells, and while the eggs are still unhatched send out a swarm, leaving to the bees that remain in the stock the care of the still unborn princesses. On the other hand, when an artificial swarm is taken from a stock it only rarely happens that queen cells have been prepared, because, although a stock may be strong enough to yield a swarm, the bees may have no present intention of throwing off their surplus population.

Between the taking of a swarm by artificial methods and the issue of a cast, from fourteen to seventeen days generally elapse; every argument, therefore, in favour of providing stocks which have sent out natural swarms with queens or ripe queen cells will carry still greater weight when applied to stocks from which swarms have been taken artificially, because the period of queenlessness is longer in the latter case than the former, and the loss is therefore greater.

Again, it must not be forgotten that bees have the power, and frequently use it, of raising a queen from worker larvæ not more than three or four days old; and when this power is used a shorter period will consequently elapse between the formation of the royal cell and the issue of the young queen. These queens are inferior to those raised from eggs. The reason for the superiority of queens raised from eggs is that larvæ intended to develop into workers only have not the advantage of receiving from the day of their birth the special food with which larvæ intended from the time of their issue from the egg to furnish queens are supplied in prodigal abundance. The ovaries are consequently not fully developed, and the laying powers are crippled to a greater or less extent.

Queen cells, to continue, remain capped eight days before the perfect queen emerges from the cell; it follows, therefore, that if queen cells are capped on or before the date of the issue of the swarm, an interval of nine days from the day when the royal cells were capped must elapse before the issue of a cast. Now, since royal cells are sealed on the ninth day, it also follows that if some of the royal cells are not capped when the swarm issues the cast will be delayed by a period of days proportionate to the time elapsing after the issue of the swarm before the cells are sealed. As a general rule a cast issues nine or ten days after the swarm, but in this, as in most other matters connected with bee-keeping, there is no invariable rule.

Sufficient has been said to show that a period of fifteen days at least elapses between the deposit of the egg in the cell and the issue of the perfect queen. In from six to seven days afterwards the young queen goes forth to meet the drone, and if successful in her marriage flight at once begins her life of labour. Thus from the time when the old queen leaves the hive a period of twenty-three days at least elapses before another egg is laid. It is easy to perceive that this means a very considerable loss to the bee-keeper, for on the ninth or tenth day after the departure of the swarm all the larvæ will have passed beyond the feeding stage, and no more eggs being deposited, the bees will be set free from their nursery work while many of them are yet unfit to perform the more active work of the hive by going to the fields for honey and pollen. In twenty-three days a good queen

will lay some 46,000 eggs; if, therefore, we leave to the bees of the old stock the duty of queen-raising, we do so at terrific loss and without any compensation to adjust the balance. It is the duty of every practical bee-keeper to provide queens or ripe queen cells for every stock, and so to overspan the interval of queenlessness. In doing this not the slightest difficulty need be apprehended, because after the issue of a swarm the vast majority of the bees remaining in the old stock are young and unable to leave the hive, while those older bees which do remain are perfectly willing to accept a queen, or even a ripe queen cell.

If a queen can be obtained she may be allowed to run in at the entrance an hour or two after the departure of the swarm. She will be gladly received, and queen cells will be at once destroyed. But if a queen cannot be procured a ripe queen cell may very possibly be obtained, and although there is a loss of some days when a queen cell is inserted before the princess emerges from the cell and becomes fertile, still there is a saving of at least fourteen days, and consequently a profit to the bee-keeper. It has been said that the perfect queen emerges from the cell on the sixteenth day. We know that the cells are capped on the ninth day, and that an interval of eight days elapses between the capping of the cell and the issue of the perfect queen; if, then, we can ascertain when the cell was capped, the day of the issue of the princess is shown at once, and we may lay our plans accordingly. Again, even if we are unable to discover the date of capping, still we may detect the age and ripeness of a cell by the "chamfering" process which the cell undergoes when the princess is almost ready to emerge from the cell.

Queen cells should not be inserted on the day when the swarm issues, but on the following day, otherwise the bees may destroy the princess while still in the cell, and thus frustrate our efforts. It is very easy to insert these cells in any form of hive, and if care is taken not to shake, chill, or bruise the still unborn princess, no difficulty need be apprehended. When cutting a queen cell from the comb on which it has been formed, a piece of comb should be cut away with it for ensuring more safety in handling the precious cell, and also to simplify the process of insertion in the queenless stock. Going up to the hive in which the cell is to be inserted, we remove the covering and place the cell hanging in its natural position—almost invariably head downwards—between the two centre combs, and fixing it in that position either by simply pressing the comb to which the queen cell is attached into the top of the centre combs, or on to the frames, or by means of a pin or small wooden skewer. Pressing the piece of comb from which the cell depends into the top of the comb is always sufficient to hold the cell in position if properly managed.

There are other and more difficult methods, but it is hardly necessary to describe them, for practical bee-keepers generally adopt the simplest plans in preference to the more difficult manipulations in which many theorists delight. It must not be forgotten that on the sixth or seventh, and possibly following days, after the perfect princess emerges from the cell, if the weather is fine, warm and sunny, about noon the princess goes forth on her marriage flight. The dangers attending these excursions are great, and are fatal to many queens. Every hive should have some distinguishing mark, in order to assist the queen on her return to discern her home; for want of this many queens enter other hives, and are lost. Happily for the bee-keeper, when once the object of the

marriage flight has been accomplished the labour of life begins, and the queen mother leaves love to those unfortunate creatures of creation who have more need of its solace, and lead less busy and industrious lives.

The careful bee-keeper will ascertain as soon as possible if the queen has become a mother. For this purpose it is absolutely necessary to inspect the combs and see that eggs have been deposited, unless the bee-keeper has sufficient experience to detect from the manner of the bees the absence or presence of a fertile queen. Two points, it will be observed, need special attention with regard to the introduction of queens and royal cells to stocks from which swarms have issued:—

1. A queen may be run in at the entrance an hour or two after the issue of a swarm.

2. A ripe queen cell should not be inserted until the following day.

At present no attempt has been made to describe the simplest and easiest method of procuring queens and ripe queen cells. This is a subject of such great importance that it has a distinct claim for separate consideration, and must accordingly be deferred, together with the "introduction of queens" to stocks deprived of a fertile worker by other means than the issue of a swarm. One thing is certain beyond all doubt, and that is the impossibility of overrating the important assistance given to the bees when a queen or ripe queen cell is inserted with the least possible delay after the old queen has departed. The loss of three weeks ovidepositing in the height of the season is irreparable; the loss to the bee-keeper is aggravated by the certain issue of at least one cast, and possibly more; by the possible loss of the cast, and the trouble of hiving and returning the cast to the old stock, and consequent loss of time; by the knowledge that if the cast is hived separately the old stock is depopulated to an extent which forbids all hope of surplus honey, and the additional certainty that the cast itself will in many years not build up into a satisfactory stock for wintering without considerable trouble and expense. It is so easy to avoid all this trouble and anxiety that the bee-keeper who does not assist his bees and save himself from this unsatisfactory position must be severely blamed for his negligence, and must in no case expect sympathy in misfortune.—FELIX.

#### MAY SICKNESS—HONEY FAIRS.

In answer to "A. L. B.," I am sorry that I did not clearly explain that "May sickness" is due most probably to the fact that the bees gather pollen in or about the mouth of May which has been touched by the frost, and not to their eating the old pollen which has been stored up in the hives during the winter. The latter is usually thrown out by the bees in the early spring, though that contained in the combs on which the bees cluster during the winter is probably used for the young brood hatched in the early part of the year. That it must be fresh frosted pollen which is the cause of the disease is shown by the fact that it generally occurs at the early part of the summer. If it were due to the old pollen the effects would be seen much earlier in the year.

With regard to the purchase of honey by the British Honey Company, we as traders can only buy as much as we consider will meet the demand. Our sales are steadily increasing, and we sold considerably more honey last year than we did in the corresponding months of the year before.

In the early part of this year there was great difficulty in getting sections, and several large orders had to be cancelled. Anyone who could devise some certain way of preventing granulation in sections would make his fortune, as the price of sections naturally rises in the winter and early spring before the new sections come into the market in any quantity.

However carefully sections are kept in a warm room the least draught will set them granulating, and even if they are delivered in good condition to the grocers, &c., it is only to be returned in a few days, as the public will not buy granulated sections.

Honey fairs are a great boon to bee-keepers if they are properly managed, but my time is so fully occupied that I must decline the tempting offer of working in unison with Mr. Hewitt.—GEO. WALKER, Wimbledon.

#### TRADE CATALOGUES RECEIVED.

Hooper & Co. (Limited), Covent Garden and Maida Vale.—*Bulb Catalogue (Illustrated), 1887.*

J. W. Silver, Norbury and Streatham, London, S.W.—*Bulb Catalogue, 1887.*



## TO CORRESPONDENTS

All correspondence should be directed either to "THE EDITOR" or to "THE PUBLISHER." Letters addressed to Dr. Hogg or members of the staff often remain unopened unavoidably. We request that no one will write privately to any of our correspondents, as doing so subjects them to unjustifiable trouble and expense.

**Parsley** (*J. Carter, Keighley*).—The Parsley plant is exceptionally fine, filling a half-bushel basket, and the large leaves are sufficiently curled to satisfy the most exacting cook for garnishing purposes.

**Proliferous Leek** (*W. G.*).—It is not unusual for bulbets to form in the flower heads of Leeks, though it is not common to find them so numerous as in the specimen you have sent. Plants may be raised from these bulbets the same as from seed.

**Viola** (*J. W. M.*).—The flowers sent were quite curled up through having been placed in the box without any damp packing to keep them fresh. We can only judge, therefore, of the colour, and this does not appear to be distinct from that of other varieties, nor is it so rich as in some of them.

**Glazing** (*J. G. H., New Jersey*).—The roofs of greenhouses may be glazed quite watertight by bedding the glass well and firmly in a rather thick bed of good putty. If the work is well done not a drop of water will pass through, whether putty be used on the top of the glass or not. We do not use top putty, but paint the sashbars well, including a strip on the glass as wide as the rebate on which it rests.

**Black Grape for Growing with Muscats** (*E. H. B.*).—Alicante would be the most likely Grape to suit you, as you do not require one that needs particular treatment, the flavour being similar to the Frankenthal and Black Hamburgh, which is what we apprehend you require, with good keeping properties. It would succeed admirably inarched on the Frankenthal, which makes a good stock, and you will get a much more satisfactory Vine in very much less time that way than by planting a young cane.

**Plunging Material** (*W. H. W.*).—The pipes should be covered with rubble, such as broken bricks, or anything through which the heat can rise, and then with a layer of long fibre, rushes, or anything that will prevent cocoa-nut fibre refuse or sawdust from passing down. There is nothing better than the fibre refuse as a plunging medium, but sawdust will answer in its absence. It should be kept moist throughout, not on the surface merely. Boiling water will destroy the fungoid growths.

**Aspect for Vinery** (*Inquirer*).—We have seen very good Grapes grown in vineries facing both east and west. As a rule, we think the eastern aspect would be preferable, care being taken to open the ventilators very early in the morning, or soon after the sun shines on the roof. The top ventilators should not be entirely closed at night in hot weather. When houses have a western aspect the sun does not reach them until it is very high and hot, and unless great care is exercised in management scorching is liable to occur.

**Mealy Bug on Grapes** (*D. W.*).—We are sorry you did not see the invader sooner. We are not sure you have done right in cutting off all the foliage, but everything would depend on its condition. We can only recommend you to try the application of methylated spirits with a very small brush that can be worked between the berries. It is a tedious process, but must be regarded as the penalty for past oversight. The insects are, at least, as likely to have passed from the Vines to the Ferns as from the Ferns to the Vines.

**Fruit Trees in Disused Quarry** (*Ignoramus*).—You had better ask one or two practical gardeners to inspect the quarry before purchasing it, as it is scarcely possible that you can make the exact nature of the soil clear to us in a short letter. One of the best orchards we know is in a quarry. The soil over the roots of the trees was covered with a thick layer of manure annually for four or five years and left to decay. Good soil was placed round the roots when the trees were planted—a barrowful or so to each tree. They are now large, healthy, and productive.

**Protecting Fruit from Wasps—Chemical Manure** (*F. I.*).—The material you enclose is too much worn to exclude wasps and blue-bottle flies. When new or in good condition it would probably do so, but medium scrim is better. The sample you sent would of course exclude birds. We have tried most of the advertised manures, and have found them all excellent fertilisers—they are all good. If you wish for something to prepare some yourself, then we recommend nitrate of soda, kainit, superphosphate of lime, and sulphate of ammonia in equal proportions by weight, thoroughly mixed, and applied at the time of putting in the crops at the rate of 3 lbs. per square rod. To apply manures of the kind indicated at the time of trenching is to waste most of their fertilising properties. In reference to your other question the matter can only be tested by experience.

**Downton Nectarines** (*J. Gilbert*).—Yours are very fine fruit indeed of this variety, which you say weigh 5½ ozs., and measure 8½ inches in circumference. It is thus described in the "Fruit Manual": "Fruit rather larger than *Violette Hâtive*; skin pale green in shade, but deep red next the sun; flesh pale green, reddish at the stone, melting, juicy, and richly

flavoured; flowers small; glands kidney shaped." We have no record of its weight. It is now gradually being superseded by the newer kinds raised by Mr. Rivers of Sawbridgeworth. The following weights and sizes of Nectarines grown by Mr. Divers at Ketton Hall, Stamford, may prove interesting to you: Lord Napier, 10½ inches in circumference, weight 7 ozs.; Rivers' Orange, 8½ inches, weight 5 ozs.; Pine Apple, 9 inches, weight 6 ozs. Possibly other cultivators may be enabled to state they have grown still larger fruit, but those indicated are above the average.

**Cactus and Decorative Dahlias (E. T. H.).**—Dahlias like deep rich soil and a sunny position, with abundance of water and mulchings of manure in hot weather. The reason your plants have not flowered better on the south side of your house is because the soil was not good enough to a sufficient depth, or the water supply insufficient during the tropical summer. Besides, the variety Juarez is later in flowering than many others. Dahlias in rather shaded places have flowered better than usual this year. The following are good varieties for cutting and garden decoration: Constance, white, free; Cochineal, rich crimson; General Gordon, bright scarlet; Glare of the Garden, scarlet, very floriferous; Mrs. Tait, white; Mrs. Hawkins, sulphur yellow; Picta formosissima, orange and scarlet; William Pearce, bright yellow. The bouquet varieties are also highly suitable for the purpose indicated.

**Ventilating Vineries (Kittie).**—Air should be admitted by the top ventilators before the sun heats the house to a degree that the moisture condenses on the berries and covers them like a film. A little artificial heat is also desirable at this season to prevent the berries getting extremely cold. Read Mr. Iggulden's article on page 201. Leaving vineries closed too long in the morning, so that the Grapes become covered with dew, then throwing both top and front ventilators widely open at once, is quite the reverse of good practice, because the excessive evaporation from the berries often causes them to be so chilled that a shrinkage results that is known as scalding. This may not always happen, but if all the Grapes escape injury it will be more by good luck than good management. We have seen very good Melons grown in fresh turves piled on each other and trodden firmly, but loam of a heavy nature that has been stacked for a time is generally preferable.

**Bougainvillea splendens and Jasminum gracillimum (Mrs. D.).**—This species of Bougainvillea is rather shy flowering, and very rarely gives general satisfaction when grown in a close moist stove. If grown in an intermediate temperature, confined at the roots, and fully exposed to the full force of the sun it flowers freely. Cutting back your plant only induces it to produce stronger growth, which is too soft to produce flowers, and we fear the plant will not do so in its present position. If you can give it cooler treatment and induce the formation of wood that possesses solidity we do not see why your plant should not flower profusely. The Jasminum should flower during autumn and winter, and whether it flowers freely or the reverse entirely depends upon the wood being thoroughly ripened, or the reverse. Very frequently this plant is grown too warm, and under conditions that are too shady to insure the wood being hard and well ripened. The best results follow growing the plant under intermediate treatment, or in a warm greenhouse during the summer fully exposed to the sun, and then placed in the stove to develop its flowers. Early in the year, before signs of fresh growth are visible, prune this season's wood well back and expose the new growth as it is made to full light and sunshine, then we do not doubt that your plant will flower.

**Bulbs (Spartan).**—Although you are "in the trade" we do not agree with the strong verdict you pass on seedsmen generally, and we think the majority of them know "old bulbs of Hyacinths, Tulips, and such like, of last year from new bulbs." Still, you are to be commended for seeking information. It injures bulbs to ruthlessly tear off the outside husks or skins, and only those parts should be removed that can be rubbed off easily with the hands, as in preparing Onions for storing; there must be no peeling. The outside scales are analogous to the bark of a tree that protects the interior; but if the bark is loose and dead it decays and invites insects. Remove, then, only those husks from bulbs that are obviously loose and dead, and which pass off easily when lightly rubbed in the palm of the hand. If sound bulbs are kept long out of the ground they push growth, and if this is allowed to extend beyond a certain limit the bulb will be exhausted, and decay if placed in the ground; if not quite so far advanced the spike may extend, and perhaps flower, but the bulb will perish, or the new bulbs that form will be so small as to be useless. That is why so many Crocuses that are planted late, after having pushed growths an inch long from the crowns, flower but never come up again. The more thinly bulbs are stored, and the cooler and drier they are kept, the longer is growth retarded. If you place Potatoes in large heaps they will push long sprouts rapidly, but packed in a single layer they are tardy in pushing. If bulbs of last year are kept out of the ground all the summer following they will be soft and spongy, especially round the neck, and worthless; in fact most of them will be dead, though a vestige of life may be found in a few. One of the chief factors of success in growing bulbous plants is to plant the bulbs early and grow the plants steadily. The greater the root extension in the earth before the growths appear above the soil, the stronger will be the plants and the finer their flowers.

**Names of Fruits.**—The names and addresses of senders of fruit to be named must in all cases be enclosed with the specimens, whether letters referring to the fruit are sent by post or not. The names are not necessarily required for publication, initials sufficing for that. Only six specimens can be named at once, and beyond that number cannot be preserved. (E. B.).—Washington Plum. (J. Weaver).—Mitchelson's Plum. (Richard Fowler).—It is too early in the season to name late-keeping fruits, but we do the best we can for you. 1, Figue de Naples; 2, Doyenné du Comice; 4, Millot de Nancy. (R. P. S.).—1, Downton Pippin; 2, Cox's Pomona; 3, London Pippin; 4, Warner's King; 5, Early Harvest; 6, not known. (H. A. D.).—1, Figue de Naples; 2, Old Colmar; 3, Louise Bonne of Jersey. (W. L.).—Not known.

**Names of Plants.**—We only undertake to name species of plants, not varieties that have originated from seed and termed florists' flowers. Flowering specimens are necessary of flowering plants, and Fern fronds should bear spores. Specimens should arrive in a fresh state in firm boxes. Slightly damp moss or soft green leaves form the best packing, dry

cotton wool the worst. Not more than six specimens can be named at once. (J. F.).—The Roses you have sent are varieties of florists' flowers, and such we do not undertake to name. Send them to the nurseryman who supplied the plants. (R. C., Bromsgrove).—*Odontoglossum bictonense*. (S. W. L.).—The Orchid is *Acineta densa*. (H. G. B.).—The flowering plant is *Helianthus argophyllus*; the other was too shrivelled.

COVENT GARDEN MARKET.—SEPTEMBER 14TH.

MARKET completely glutted with drop fruit. Prices all round much lower.

FRUIT.

	d.	s. d.		s. d.	s. d.
Apples, ½ sieve .. ..	1	6	to	3	6
Nova Scotia and Canada barrel	0	0		0	0
Cherries, ½ sieve .. ..	0	0		0	0
Cobs, 100 lbs. .. ..	0	0		50	0
Figs, dozen .. ..	0	9		1	0
Grapes, per lb. .. ..	0	6		2	6
Lemons, case .. ..	10	0		15	0
Melon, each .. ..	0	6		1	0
Oranges, per 100 .. ..	6	0	to	12	0
Peaches, dozen .. ..	2	0		6	0
Pears, dozen .. ..	1	0		1	6
Pine Apples, English, per lb. .. ..	1	6		0	0
Plums, ½ sieve .. ..	1	6		2	6
St. Michael Pine, each	3	0		5	0
Strawberries, per lb. ..	0	0		0	0

VEGETABLES.

	s. d.	s. d.		s. d.	s. d.
Artichokes, dozen .. ..	1	0	to	2	0
Asparagus, bundle .. ..	0	0		0	0
Beans, Kidney, per lb. ..	0	3		0	0
Beet, Red, dozen .. ..	1	0		2	0
Broccoli, bundle .. ..	0	0		0	0
Brussels Sprouts, ½ sieve	0	0		0	0
Cabbage, dozen .. ..	1	6		0	0
Capicums, per 100 .. ..	1	6		2	0
Carrots, bunch .. ..	0	4		0	0
Cauliflowers, dozen .. ..	3	0		4	0
Celery, bundle .. ..	1	6		2	0
Coleworts, doz. bunches	2	0		4	0
Cucumbers, each .. ..	0	4		0	6
Endive, dozen .. ..	1	0		2	0
Herbs, bunch .. ..	0	2		0	0
Leeks, bunch .. ..	0	3		0	4
Lettuce, dozen .. ..	0	9	to	0	0
Mushrooms, punnet .. ..	0	6		1	0
Mustard and Cress, punt.	0	2		0	6
Onions, bunch .. ..	0	3		0	6
Parsley, dozen bunches	2	0		3	0
Parsnips, dozen .. ..	1	0		0	0
Potatoes, per cwt. .. ..	4	0		5	0
" Kidney, per cwt. .. ..	4	0		0	0
Rhubarb, bundle .. ..	0	2		0	0
Salsafy, bundle .. ..	1	0		1	6
Scorzoneria, bundle .. ..	1	6		0	0
Seakale, basket .. ..	0	0		0	0
Shallots, per lb. .. ..	0	3		0	0
Spinach, busbel .. ..	3	0		4	0
Tomatoes, per lb. .. ..	0	4		0	6
Turnips, bunch .. ..	0	4		0	6

PLANTS IN POTS.

	s. d.	s. d.		s. d.	s. d.
Aralia Sieboldi, dozen ..	6	0	to	12	0
Arbor vitæ (golden) dozen	6	0		9	0
" (common), dozen ..	0	0		0	0
Asters, dozen pots .. ..	3	0		6	0
Azalea, dozen .. ..	0	0		0	0
Begonias, dozen .. ..	4	0		9	0
Capicums, dozen .. ..	6	0		9	0
Cineraria, dozen .. ..	0	0		0	0
Creeping Jenny, dozen ..	0	0		0	0
Dracæna terminalis, doz.	30	0		60	0
" viridis, dozen .. ..	12	0		24	0
Erica, various, dozen .. ..	9	0		18	0
Euonymus, in var., dozen	6	0		18	0
Evergreens, in var., dozen	6	0		24	0
Ferns, in variety, dozen	4	0		18	0
Ficus elastica, each .. ..	1	6		7	0
Foliage Plants, var., each	2	0		10	0
Fuchsia, dozen .. ..	3	0	to	9	0
Geranium (Ivy), dozen ..	0	0		0	0
" Tricolor, dozen .. ..	0	0		0	0
Gladiolus .. ..	4	0		6	0
Hydrangea, dozen .. ..	9	0		12	0
Lilies Valley, dozen .. ..	0	0		0	0
Lilium lancifolium, doz.	12	0		18	0
" longiflorum, doz. ..	0	0		0	0
Lobelia, dozen .. ..	0	0		0	0
Marguerite Daisy, dozen	6	0		12	0
Mignonette, dozen .. ..	3	0		6	0
Musk, dozen .. ..	0	0		0	0
Myrtles, dozen .. ..	6	0		12	0
Palms, in var., each .. ..	2	6		21	0
Pelargoniums, dozen .. ..	6	0		12	0
" scarlet, doz. .. ..	3	0		9	0
Spiræa, dozen .. ..	0	0		0	0

CUT FLOWERS.

	s. d.	s. d.		s. d.	s. d.
Abutilons, 12 bunches ..	2	0	to	4	0
Anemones, 12 bunches ..	0	0		0	0
Arum Lilies, 12 blooms ..	3	0		6	0
Asters, 12 bunches .. ..	2	0		6	0
" French, bunch .. ..	1	6		2	0
Azalea, 12 sprays .. ..	0	0		0	0
Bluebells, 12 bunches ..	0	0		0	0
Bouvardias, bunch .. ..	0	6		1	0
Camellias, blooms .. ..	0	0		0	0
Carnations, 12 blooms ..	1	0		2	0
" 12 bunches .. ..	4	0		6	0
Cornflower, 12 bunches ..	1	6		3	0
Dahlia, 12 bunches .. ..	2	0		4	0
Daisies, 12 bunches .. ..	2	0		4	0
Encubias, dozen .. ..	2	0		4	0
Gardenias, 12 blooms ..	2	0		5	0
Gladiolus, 12 sprays .. ..	1	0		1	6
Hyacinths, Roman, 12 sprays	0	0		0	0
Iris, 12 bunches .. ..	0	0		0	0
Lapageria, white, 12 blooms	1	6		3	0
Lapageria, coloured, 12 blooms	1	0		1	6
Lilac (white), French, bunch	0	0		0	0
Lilium longiflorum, 12 blooms	2	0		3	0
Lilium lancifolium, 12 blooms	0	6		1	0
Lilies, White, 12 bunches	0	0	to	0	0
" Orange, 12 bunches	0	0		0	0
Lily of Valley, 12 sprays	0	0		0	0
" 12 bunches .. ..	0	0		0	0
Marguerites, 12 bunches	2	0		6	0
Mignonette, 12 bunches	1	0		3	0
Myosotis, 12 bunches ..	1	6		3	0
Narciss, 12 bunches .. ..	0	0		0	0
" White, English, beh.	0	0		0	0
Pansies, 12 bunches .. ..	0	0		0	0
Peas, Sweet, 12 bunches ..	1	6		3	0
Pelargoniums, 12 trusses	0	9		1	0
" scarlet, 12 trusses	0	3		0	6
Pinks, White, 12 bunches	0	0		0	0
" various, 12 bunch	2	0		4	0
Poinsettia, 12 blooms ..	0	0		0	0
Primula (single), bunch ..	0	6		0	0
" (double), bunch .. ..	0	9		1	0
Polyantus, 12 bunches ..	0	0		0	0
Ranunculus, 12 bunches	0	0		0	0
Roses, 12 bunches .. ..	2	0		6	0
" (indoor), dozen .. ..	0	9		1	0
" Tea, dozen .. ..	1	6		3	0
" red dozen .. ..	0	0		0	0
" de Moix, 12 bunches	0	0		0	0
Stephanotis, 12 sprays ..	2	6		4	0
Tropeolum, 12 bunches	0	0		0	0
Tuberose, 12 blooms .. ..	0	6		1	0
Tulips, dozen blooms ..	0	0		0	0
Violets, 12 bunches .. ..	1	0		1	6



KEEPING A COW.

It is a general fault that cows are turned out of the yard to graze upon grass in spring before it is ready.



Nor can we wonder at this, knowing as we do how frequently the store of winter food runs short in March, and how poor in quality the milk is then. Now "H. S. E." has an acre of land which he laid down to permanent pasture in spring with a crop of Oats. In common with many other young pastures this year it has proved a failure owing to drought, and "H. S. E." wishes to know what he is to do with it. We would not have it in permanent pasture at all, but have half an acre of Perennial Rye Grass, a quarter of an acre of Rye, and the remainder for Carrots, Mangold, and Cabbage. Let the Rye be sown at once at the rate of 3 bushels to the acre, and if the Rye Grass can be sown not later than the second week in September it will answer in the south and in the midlands, otherwise it must be sown next April either with or without a corn crop. The Rye is generally ready for use early in March, enough being mown daily and taken to the yard for the cows. If the ears appear before it is all used it should be passed through the chaff cutter and mixed with an equal quantity of dry chaff. After being mown the Rye starts quickly into growth again, and a second crop follows equal to or even superior to the first, especially if it is assisted by a dressing of sewage or nitrate of soda. If the land is not rich in fertility we would scatter half a hundredweight of nitrate of soda upon the Rye early in February, and repeat the dressing for the second crop. The Rye Grass should also have similar treatment, the bulk of the crop depending very much upon a liberal use of manure.

Where land can be had there should always be a crop of winter Oats sown either late in September or early in October to follow the Rye, and so enable us to turn the first growth of Rye Grass to account for hay, which ought to afford an ample supply for winter use. The second crop if helped with manure ought to be as vigorous as the first, and may either be turned to account for grazing or hay. If land can be had for some spring Tares, then the second growth of Rye Grass ought certainly to be made into hay. The spring Tares come into use in early summer, and one or two successional sowings afford a valuable supply of green succulent food when pastures are often parched and brown.

The possession of an acre or so of grass land is frequently an inducement to purchase a cow in view of having plenty of milk. Such an idea is natural enough, but results show that it is impracticable. A meadow with part fenced off for hay and the other part devoted entirely for grazing may answer the required purpose if it is heavily manured, but there can be no question that the method of culture we have described answers best. It affords a much greater bulk of food, and, what is of equal importance, it enables us to impart a wholesome variety to our dietary. But if in addition to a field under alternate husbandry, another can be had in permanent pasture, by all means let us have it; only we would always make it a secondary matter regarding the field under plough or spade culture as quite indispensable. To be really profitable, or rather as productive as possible, the pasture should consist entirely of plants suitable for the growth of sweet, wholesome herbage, and all other plants springing up in it are to be regarded as weeds and rooted up. Of such the most common and mischievous are Nettles, Thistles, Docks, Rushes, Ononis or Rest Harrow, Broom, Brambles, and Sedges. A somewhat wide experience has brought us into contact with pastures infested with one or other of these pests. Rushes and Sedges indicate a want of drainage, attention to

which leads to their gradual decay, and they are quickly replaced by a growth of natural Grasses and Clover. The only remedy for the other weeds is to root them up, and not to attempt to get rid of them by cutting off the part above the surface. In Sussex, on the Hastings sand formation, Brambles of the common Blackberry spring up so thickly that we once had several waggon loads cleared off a few acres of old neglected pasture. In Suffolk, Ononis infests pasture both in mixed soil and heavy land, upon chalk and chalk marls, often so badly as to quite spoil it. When it thus spreads pasture is of very little use either for hay or grazing, and the only remedy is either to root up the Ononis with spades or to pare and burn the sods, to plough and lay down again with a really good mixture of Grasses and Clovers. A well managed meadow repays us well for our care, and strictly according to it, for we have one or several tons of rich herbage per acre annually from it, the greater bulk arising from the free use of manures.

(To be continued.)

#### WORK ON THE HOME FARM.

Harvest work was brought to a speedy and satisfactory conclusion in from three to four weeks, the corn being saved in excellent condition. The weather became broken soon afterwards, and enough rain had soon fallen to soften the surface sufficiently to admit of good work being done with harrows upon the stubbles, and gladly did we see Charlock seed springing into growth. We shall indeed be fortunate if we can induce germination of all the seed of this pest before the deep ploughing is done, and thus avoid a heavy outlay for hoeing next spring. Ploughing of clean land and sowing of Rye has been done, as we like to have a full strong plant of this useful green crop forward in growth before winter. Severe frost may render it somewhat brown, but it does no material harm, and the strong plant gives an abundant early growth in spring. To those of our readers who have not yet sown some Rye we say, Do so at once, and you will have an invaluable supply of green food next March just when your store of winter food may run short. It can be given to horses, cows, or bullocks in yards, and sheep with lambs may be passed over it twice in folds. Land must be got ready speedily for Tares, Wheat, and winter Oats. Where only a few acres of Oats are grown we strongly advise that preference be given to the hardy Tawney Winter Oat, which on good land always yields a heavy crop of corn; the straw affords a supply of nutritious chaff for horses, and the growth may also be found of great service for sheep in a late spring, when it may be eaten off closely, and it will soon start into growth again, and will subsequently yield a useful supply of corn. Let all possible care be taken to select good seed of the best sorts of Wheat, and to get the sowing done before the soil becomes so wet as to render harrowing a difficult and unsatisfactory process. Let the seed be steeped in water in which blue vitriol is dissolved, and take especial care to use seed without the taint of smut. We have since harvest heard of some new Wheat being sold at £1 a quarter weighing 63 lbs. to the bushel, but so badly affected by smut that it had to be sold for full 10s. below market price. It is doubtless owing to carelessness in the selection and preparation of our seed that blight and other disease become so widespread.

#### METEOROLOGICAL OBSERVATIONS.

CAMDEN SQUARE, LONDON.

Lat. 51° 33' 40" N.; Lon<sup>g</sup>, 0° 8' 0" W.; Altitude, 111 feet.

DATE.	9 A.M.					IN THE DAY.				Rain	
	Barometer at 32° and Sea Level.	Hygrometer.		Direction of Wind.	Temp. of soil at 1 foot.	Shade Temperature.		Radiation Temperature.			
		Dry.	Wet.			Max.	Min.	In sun.	On grass.		
1887.		deg.	deg.		deg.	deg.	deg.	deg.	deg.	In.	
September.	Inches.										
Sunday .....	4	29.685	60.5	56.8	S. W.	59.0	67.8	55.0	110.2	51.2	0.041
Monday .....	5	29.578	57.9	55.4	S. W.	59.7	65.4	53.7	91.7	51.1	0.039
Tuesday .....	6	29.599	60.8	55.1	S.	59.3	69.5	55.6	113.9	52.3	0.103
Wednesday ..	7	29.631	58.8	54.9	S.	59.2	67.2	52.3	114.6	46.9	0.086
Thursday .....	8	30.410	53.7	47.8	S. N.	58.2	59.9	39.0	91.6	34.3	—
Friday .....	9	30.254	55.4	51.5	S. N.	56.4	67.9	42.1	112.2	37.2	0.035
Saturday .....	10	31.015	56.9	52.1	N.	57.2	64.2	53.4	111.0	51.2	—
		29.879	57.7	53.4		58.5	60.4	50.2	107.0	49.3	0.255

#### REMARKS

4th.—Bright gusty morning; cloudy afternoon with spots of rain; showers in evening.  
 5th.—Wet morning; afternoon generally bright and breezy; fine evening.  
 6th.—Fine and generally bright, though with dark clouds about.  
 7th.—Rain early; morning generally bright, with rain at 11.15 A.M. and 1.2 P.M.; afternoon overcast, with spots of rain; fair evening.  
 8th.—Fresh clear morning, foggy about noon, and hazy all the afternoon.  
 9th.—Foggy early; fine day; cloudy after 5 P.M., with spot of rain in the evening.  
 10th.—Shower early; generally fine, with some sunshine; evening fair but not bright.  
 Temperature lower than last week, and very near the average; rainfall below it.—  
 G. J. SYMONS.



## COMING EVENTS

22	TH	
23	F	
24	S.	
25	SUN	16TH SUNDAY AFTER TRINITY.
26	M	
27	TU	
28	W	Royal Horticultural Society—Fruit and Floral Committees at 11 A.M.

### FLORAL DECORATIONS.

**I**NCREASING attention has for some years been paid to the encouragement of competition in floral decorations at exhibitions, and it is evident that this has contributed greatly to the improved taste now generally manifest in work of that kind. It is also a department in the shows that is very popular, especially amongst the ladies, and wherever there is a good display of stands, bouquets, wreaths, &c., that will usually be found the most crowded portion of the exhibition. Even those who become tired of contemplating large specimen plants that appear with such regularity at a series of shows each year, can find something fresh and interesting in the floral competition. Recognising some of these facts certain horticultural societies have strengthened that part of their schedules devoted to the decorative art with considerable benefit to their exhibitions and the public. There is, however, room for a much greater advance in this respect, as fortunately such classes are not confined to any particular period in the year. They are as suitable at the November Chrysanthemum shows as during spring or summer, and at the first named they are becoming quite a permanent feature. Flowers and foliage are now used so extensively in houses of all kinds that there is no difficulty in obtaining competitors where sufficiently substantial prizes are offered. In some country districts the advance has been so rapid that this portion has developed into almost a show of itself, as for example at Bickley in Kent, and Shepperton, where one large tent scarcely suffices to hold all the entries.

At the larger shows, or when the funds are sufficient for the purpose, prizes are offered for tables arranged for a specified number of persons, usually from six to twelve. Classes are also devoted to stands of flowers, either single, in pairs, or threes. These can be still further diversified in autumn by providing classes for stands of berries and foliage, which produce some pretty results. Then there are the bridal and other bouquets, ladies' wreaths and buttonhole bouquets, all of which constitute interesting classes. In reviewing some of the special features of these classes a few words may be first devoted to the table decorations, since they are regarded as the most important, and for them the largest prizes are provided. When a class is devoted to this form of decorative art it is commonly stipulated that the table shall be fully dressed—that is, set out with dessert, wine glasses, plates, knives and forks, serviettes, &c., and we have seen several tasteful arrangements disqualified for non-compliance with these conditions, but it is sometimes allowed that the stand glasses for flowers and fruit will suffice, thus relieving the exhibitors of some difficulty.

For the larger tables, say for ten or twelve persons, three epergnes are generally employed in the centre, and so much diversity of taste exists with regard to the kind employed that the character of the table mainly depends upon these. Some have a fancy for tall glass epergnes with a large central trumpet and a number of branches in tiers, and we have seen examples of these with as many as twenty small branches filled with a number of varied brightly coloured flowers, the effect producing the impression that both time and flowers had been wasted. The most elegant of these glasses are those with a well proportioned central trumpet, and perhaps one tier of branches with a bowl at the base sufficiently large to balance the upper part and admit of an effective arrangement. Then, too, there is some difference of opinion as to whether the two side stands should correspond in height with the central one, but as a rule their appearance is much better if they are somewhat smaller than the principal one. Three stands of one form and size do not admit of such varied treatment, and the table has usually a more pleasing effect when the two side stands are dressed alike, the central one as distinct in character as possible without destroying the general harmony. A still further improvement where lightness is desired is the substitution of a couple of graceful Palms for the side stands, either *Cocos Weddelliana* or *Geonoma gracilis* being admirably adapted for this purpose, but it is necessary to avoid having too marked a difference in the height of these and the central stand.

Besides the large epergnes a number of small hand classes for single flowers, such as selected Rose buds or some simple combination of the buttonhole type add much to the finish of the table arrangement, but unless some care is exercised in the selection of flowers for this purpose the general effect is easily spoiled. For instance, we recently saw a table where flowers of *Lilium lancifolium rubrum* were employed in the single glasses, and beautiful as these flowers are individually or in tasteful arrangement with other flowers, they were quite out of place in this way, and materially detracted from an otherwise good effect. Occasionally large central shallow bowls of varied design are employed instead of the glass epergnes, but as a rule they have a heavy appearance, some remarkable instances of this being shown at the Royal Botanic Society's Exhibition, Regent's Park, this summer. In the arrangement of such tables and in the flowers selected for the purpose, the chief points to be kept in view are lightness and gracefulness, yet it is in neglect of these characters that the majority of unsuccessful exhibitors err. Persons sitting at opposite sides of a table do not desire an almost impenetrable screen of flowers and foliage between them, but this seems to be the object of some decorators to provide. Excellent examples of the best styles have been submitted at all the leading shows throughout the kingdom by Mr. J. Cypher of Cheltenham, and Mr. J. R. Chard of Stoke Newington, and though each has his special characteristics in arrangement, it would be an invidious task to determine which displays the most taste. In one respect they are similar—namely, they carefully avoid heaviness and formality. When they are competing in the same classes the judges commonly have an extremely difficult task to decide which shall take precedence.

Amongst northern exhibitors Mr. Thompson, The Hermitage Gardens, Chester-le-Street, has gained considerable fame, and many substantial awards testify to his skill in this work. Another gardener who has displayed

much taste in the same direction is Mr. William Low, gardener to the Duke of Grafton, Euston Hall, Thetford, Suffolk. Though not so much known as an exhibitor as those already mentioned, his illustrated book on "Table Decorations" will render his name familiar to many who are interested in the subject. Mr. Low has made a specialty of the artistic arrangement of flowers in designs on the tablecloths, a fashion that has extended very much of recent years, and judging by the plans he furnishes some charming effects must have been produced. Of one distinct design the following description is given, and will serve to illustrate the style adopted:—"A table 12 feet in length and of the usual width of 5 feet 6 inches. The centre is adorned with three silver candelabra, and two plants of *Adiantum farleyense* in silver vases. Two dishes of fruit were placed at top and bottom of the table and four at the sides, making six dishes of fruit in all. Cut flowers in white china vases of uniform height were placed in a line with the dessert towards the ends, and were furnished with bright-coloured Geraniums and Bouvardia, with a few small fronds of Maidenhair Fern interspersed. The small circles represent small glasses filled with single scarlet Begonias, their own foliage supplying the greenery. On the tablecloth around the central candelabra was formed an eight-rayed star with straight pieces of the small neat glossy-leaved *Cotoneaster microphylla*, the rays being filled in with a finely cut fern-like leaf of herbaceous *Pyrethrum*, while close to the base of the candelabra were placed eight white *Chrysanthemums* on a fringe of green *Lycopodium*. The small circles between the rays of the star represent red *Chrysanthemums* resting on a base of Maidenhair Fern. The circle was formed of finely cut leaves of sweet-scented Geranium, on which were placed white alternated with yellow *Chrysanthemums*. The tracing is of the finely cut fern-like leaves of herbaceous *Pyrethrum*. The star-like figures around the bases of the other two candelabra were formed of *Cotoneaster*; within each ray was placed a frond of Maidenhair Fern on which rested a rose-coloured *Chrysanthemum*. The arrangement here is specially for autumn or winter, as will be seen from the fact that only *Chrysanthemums* are used on the cloth. For this reason this might be called a *Chrysanthemum table* or dinner, and these specific arrangements of one or more flowers only on the table at one time might be carried much further to the ensuring of greater distinctness and variety in the decoration of dinner tables."

In the ordinary arrangement of flowers in stands upon tables some regard must be paid to whether they are to be seen under artificial light or not, as this makes a great difference. Some of the delicately tinted flowers that have a charming effect by daylight are insignificant under gas or candlelight. Blue and purple tints, pale yellows, pale pinks, salmon or any undecided hues are usually unsatisfactory at night unless they are very carefully contrasted with brighter colours. Generally speaking the scarlets, rich crimsons, and bright solid orange tints, clear bright rose, and similar bold hues are seen to best effect. It is, however, a mistake to employ many different flowers, the too frequent result being a mixture of tints that partially obscure each other. Very beautiful effects are often obtained from the employment of one kind of flower, such as Roses or Carnations with some diversity of foliage; there is also a greater demand for fragrant flowers in this work, but not for such powerfully scented ones as *Stephanotis* or *Lilium candidum*, which are liable to become unpleasant in a room. The employment of foliage needs a little thought and care, as an excessive liberality in

Maidenhair Fern fronds repeatedly spoils good stands that as far as the flowers are concerned are admirable. Sufficient must be used to serve as a foil, to partially conceal the stands, and yet not overload them. *Asparagus plumosus* or *Lygodium scandens* are especially useful in this respect owing to their light lace-like effect, the latter being invaluable for twining round the stems or supports of epergnes or vases.

As regards bouquets, wreaths, &c., the principal secret of success lies in the skill with which the flowers are individually displayed without undue crowding or thinness. The same materials in the hands of an unskilful or untasteful person and one accustomed to the work will result respectively in the production of a "bunch" and a "bouquet" as totally distinct as it is possible to imagine. Both Messrs. Cypher and Chard are strong in the bouquet classes, but Messrs. Perkins & Son of Coventry have been extraordinarily successful for some years past, and usually their bouquets are models both in the selection of flowers employed and the style adopted. It is surprising that in amateurs' classes these forms of floral decoration are too often the least satisfactory, and for that reason alone more encouragement should be given to them in the shape of prizes.—C.

#### THE AMATEURS' VINERY IN AUTUMN.

WHEN the days are bright and the nights genial in June, July, and August Grape-growing is a simple matter, as no artificial heat is required, and with a liberal supply of air and plenty of water at the roots the Vines will grow and the Grapes swell with very little attention; but when September is declining, October and the winter coming on, and sunless days and long damp nights have to be contended with, the attention to the Vines must be greatly increased. Some small vinery owners grow early Grapes only, ripen them in July, and they are almost over by this time; but others, and the majority, grow some late varieties, and all have a desire to keep them as long as possible. The Vines, too, require to be cultivated until the foliage falls, and all who wish to succeed with their Vines and Grapes must attend to them well during late autumn and early winter.

Where water has been scarce this summer the Vines may not have had sufficient at the roots to keep the leaves quite green, and red spider and other insects may have attacked them; but it is not a good time now to clear off these, as syringing cannot be done freely at present, and the insects may be left until the foliage falls and the Vines are cleaned. They will not increase now to any extent, and will not become more harmful than they have been. Syringing would spoil the appearance of the Grapes, and if the weather were damp the fruit might be induced to decay.

Thinning the shoots, however, should have attention. All Vines in a healthy state require to have their side shoots stopped often when they are beginning to grow freely in spring, then by midsummer they are not so much inclined to make new wood; but by September many straggling shoots have pushed forth, and these often form a close mass of foliage close to the glass. This is very injurious to the Grapes, as it confines the moisture about them and obstructs both sun and air. The first operation should therefore be to cut away all these small rambling shoots, and only allow the strong growths to remain. In doing this do not allow any of the leaves to rub the fruit, or it will become greatly disfigured. None of the large leaves on the main shoots should be taken off until they are falling naturally, and all those cut off should be taken out of the vinery immediately. If there are insects in the vinery they are sure to be on these small shoots, and many of them will be cleared out with the branches. This work of clearing should not be done in a hurry, but carefully, and so as to improve the appearance of the Vines.

So much for foliage. Now for the roots. I am sure no one can remember a season when the roots of Vines stood a better chance of suffering by want of water than they have this season. Where the roots are outside the rain waters them as a rule; but there has been little of that this year, and in and near towns where many small vineries exist their chance of being watered has been equally bad, as in many instances water has been so scarce as not to be sufficient for domestic purposes. No doubt attempts have been made to keep them alive, and probably the surface of the border may have been kept moist; but is there not a great danger of their



suffering still from dryness at the bottom of the border? When once a Vine border becomes dust dry it takes a great quantity of water to moisten it thoroughly, and it may be partially watered time after time without being saturated. It is a good plan to take an iron rod and make holes here and there all over the surface of the bed to a depth of 18 inches or 2 feet, and fill these with water two or three times daily, giving the border a good watering at the same time. As a rule the borders are made on a little incline, or trodden so much on the surface that the water is more apt to run off the surface than penetrate the soil, and the holes suggested assist to take the water down to where it is most wanted. I have a great fear of having borders dry underneath at this season, as if saturation is delayed until the days are much shorter it cannot be done without making the atmosphere of the vinery very humid, and then the fruit decays; but when the border is thoroughly wet now it will do the whole autumn without any more water. The result of having a too dry border is soon shown in the fruit shrivelling prematurely.

Where the wood on the Vines has become brown and matured and the fruit is well ripened do not give them any fire heat yet, as it is not wanted for anything except to expel the damp, and so long as this does not prove troublesome the fire heat need not be introduced, but where the Grapes are still comparatively green and late a little fire heat will benefit them very much, and may be applied nightly. Give plenty of air on fine days, but keep the ventilators closed when it is damp and chilly. Where the bunches are already very close, and the berries so firm as to be a mass, many of them are sure to damp away when moisture settles on them, and the most economical way of treating them is to thin out a number of the berries and make the bunch so open that water will pass through, but not lodge amongst the berries.—A KITCHEN GARDENER.

#### VIOLAS.

I READ with great interest Mr. Jenkins's excellent practical paper on Violas, and can fully substantiate the correctness of his views as to their culture. Cow manure is a fine thing for them, and Mr. Jenkins first taught me its use at Hampton near London. One of my customers near Winchester obtained from me early in July plants of Arlwell Gem, and in sending them I told him that I greatly feared they would not do any good in the hot weather, and recommended him to dig in cow manure, not too raw, and plant deep, firm, and keep them damp, and just shaded from the midday sun, and to my surprise he wrote me recently to say how well they had done.

I induced a friend near Lichfield to grow a large bed of Violas planted out last autumn—the sorts, True Blue, Countess of Kintore, Unique, Duchess of Albany, Skylark, Countess of Hopetoun, and others, and they were in splendid bloom up to the middle of July, when I cut away all the old growth, and put in the cuttings out of doors in a shady border, and the old plants are now just a mass of splendid blooms from the second growth. It has taken some time to write the Viola into popularity, but the gardening public are now valuing this plant, and the demand for good varieties is increasing fast. I have grown this season several new varieties, and must speak in high terms of Mr. Baxter's new ones, especially Ethel Baxter, Spotted Gem, and Mrs. Baxter, and more of his very fine new varieties will be sent out next spring by Messrs. Dobbie & Co. Then Mr. Downie has some very fine new ones to send out, he having sent me blooms in the summer.

Unfortunately for the Viola so many buy and plant at the wrong time, and planting should be done in October or November, or in March or very early in April. Mr. Jenkins is quite right as to planting in drills or slightly sunken beds. I have grown all mine, some thousands, in drills from 2 to 3 inches deep, so that water supplied went direct to the roots, and with repeated rose-pot waterings in hot weather during the day. We kept down aphides, and the plants grew well, scarcely losing any. This treatment is a necessity in light porous soils, whilst on heavier soils and in shady positions it is not so necessary.

To Mr. Jenkins's list of whites let me add Mrs. Smith, a fine white free from markings. To yellows, Golden Prince Improved, a capital grower and deep yellow. In "Queen of Lilacs," one of my seedlings, we have one of the very best bedders grown, deserving all Mr. Jenkins says of it; but why is "True Blue" left out of the list? This is one of my seedlings, and far away the best blue in cultivation. Queen of Purples and Cliveden Purple compacta were raised by me, and are very fine indeed in habit, and one a light purple, the other dark. Mrs. Charles Turner is another of my seedlings, but I cannot grow it, and have nearly lost it, yet Mr. Jenkins succeeds so well with it. It is a lovely variety, and I shall have to go to him for stock of it. Duchess of Albany is a very lovely bedder, soft shaded lilac, good habit, and very free, and so distinct. York and Lancaster does not with me come in true character, only early and late, then the marking is denser in colour and brighter than in a variety I have long had under the name of Columbine. The lovely sky blue edging of "Skylark" flushes out in hot weather, and in Mr. Baxter's "Blue Cloud," to be sent out next spring, we have a broader margin of denser colour, but the same shade as in Skylark, and I hope this lovely colour will be retained in hot weather. Lord Darnley, one of my seedlings from Holyrood, which fails with Mr. Jenkins, does well with me, and the shade of colour is much richer

than in any other blue Violet, bedding Pansy or Viola we have, a most lovely variety, but, judging from Mr. Jenkins's experience in the south, is not to be relied upon as a bedding variety. The spring and summer of 1887 have been most trying.—WILLIAM DEAN, *Florist, Walsall.*

#### LAWNS IN AUTUMN.

LAWNS this autumn are somewhat different from what we have often seen them. The scorching weather disfigured them sadly, and they have not had a pleasing verdant appearance since May. The lawn mowers and scythes have had a long rest, as we cannot remember a season when they were less in demand. Where the soil is deep and the ground level the grass and roots have not suffered so much as on banks, terraces, and shallow places. On such positions the turf appeared a month ago as if it would never be green again. Newly laid turf and recently sown grass seed may fail altogether, and parts may have to be turfed during the winter or sown again next spring. Dressings of manure will not do much good when the roots are not there. A very patchy lawn can hardly ever be repaired to look well, but established lawns will recover in time. The grass may be growing very strongly on one place, while other parts may still be dead looking. This is the appearance of much of ours, and some might be inclined to leave cutting alone and allow all to grow, with the idea that this is the best way of improving the lawn; but I have repeatedly proved that it is not, and a lawn will improve more quickly under constant cutting than if allowed to grow without this attention. The cutting-down causes the plants to grow outwards and very close, and it is this which constitutes a good lawn. We have our lawn mower going daily now, and will keep it on as long as the grass continues growing, and when it ceases in winter the result will be a close carpet-like lawn. I have a great dread of seeing any of our lawn grass become long, as I know when it is cut again the surface will present a very blanched appearance. Lawns when well trimmed at this time are much more beautiful than in the spring, as the white Daisies at that season always give it a rough untidy appearance, but now there none of them, and the grass presents a uniformly green aspect.—S. W.

#### ROSES AT THE NATIONAL ROSE SOCIETY'S METROPOLITAN EXHIBITION IN 1887.

THE position taken by many of the Roses in the following lists will be found to differ considerably from those assigned to them in my analysis of 1884. This was noticed to be the case last year also. It should, however, be borne in mind that the analysis then given was based upon the results of eight previous years, and those mostly wet years; whereas the last two summers have been exceptionally dry, late seasons. Moreover, several new varieties which were at that time but little grown, have since gradually pushed themselves on into prominent places, and in this way the positions of some of our older favourites have been proportionately lowered. On the other hand, as might have been expected, the lists of this year and of last year agree fairly well together.

The total number of Roses tabulated this year has been 1770, of which 820 were shown by amateurs and 950 by nurserymen. At no previous Exhibition of the National Rose Society have so many Tea Roses been staged, and on glancing down the list it will be noticed how very frequently the best staying flowers in this division found their way into the winning stands. Of course the forcing nature of the weather at the time when the South Kensington Show was held to some extent accounts for this, and also for the comparatively low positions taken by many fine varieties, the petals of which are either not sufficiently numerous or else not so closely arranged as to be able to resist the great heat to which they were subjected. The late-flowering kinds, both among the H.P.'s and also among the Teas and Noisettes, were again placed at a further disadvantage, owing to the backwardness of the season in many localities.

The past Rose season appears to have suited the following established H.P.'s remarkably well—viz., Marie Cointet, Duchesse de Vallombrosa, Monsieur Noman, Comtesse de Serenye, Annie Laxton, Henri Ledechaux, Star of Waltham, Xavier Olibo, Abel Carrière, Prince Arthur, and Duke of Wellington; also among the Teas—Comtesse de Nadaillac, Innocente Pirola, Caroline Kuster, La Boule d'Or, Madame H. Jamain, and Jules Finger. On the other hand, La France, Baroness Rothschild, Charles Lefebvre, Duke of Edinburgh, Dr. Andry, and Captain Christy were but indifferently represented in the classes open to Hybrid Perpetuals; also in the Tea and Noisette section, Souvenir d'un Ami, Marie Van Houtte, Souvenir de P. Neyron, Devoniensis, Rubens, and notably Madame Lambard, which was scarcely anywhere to be seen.

We come now to what is the most interesting and valuable portion of our analysis owing to the light which it throws upon the relative values of the newer varieties. Taking first the H.P.'s, we find that Ulrich Brunner, which came out in 1881, now stands second only to the leading flower of the season, Madame G. Luizet; while Meveille de Lyon, which was distributed in 1882, has already

risen to the fourth place on the list. Lady Mary Fitzwilliam, which dates from the same year, has not advanced quite so rapidly, but is nevertheless only one step below such fine varieties as La France and Marquise de Castellane. Her Majesty (1886) which has appropriately made her first appearance in the exhibition stands in this Jubilee year, has already risen as high as No. 15, and will another year no doubt occupy a much higher place, being an undoubted acquisition. Violette Bouyer (1881) does not rank quite so high as in last year's list—a fact which the trying season may to some extent explain. Alphonse Soupert (1883), which did not obtain a place in the 1886 analysis, has this year risen to No. 23. On the other hand, Heinrich Schultheis (1882), Queen of Queens (1883), Rosicriste Jacobs (1880), and Pride of Waltham, have all

since then lost ground more or less. Victor Hugo (1884) just manages to creep in at the tail end of the list.

It will be observed that none of the newer Teas have as yet succeeded in securing for themselves any very high position in the list of Teas and Noisettes. In the present analysis at No. 9 we find Madame de Watteville (1883), and at No. 10 Etoile de Lyon (1881). The variety last named, notwithstanding the dry and warm summer, has, however, gone down a step or two since 1886; while Madame Cusin (1881), the Hon. Edith Gifford (1882), and the Princess of Wales (1882) only just succeed in maintaining the places they secured last year. Madame Angèle Jacquier (1882), which did not appear at all in last year's analysis, has this year risen to No. 18.

## HYBRID PERPETUALS.

Position in present Analysis.	Position in 1886 Analysis.	Position in 1881 Analysis.	Name of Rose.	Date of Introduction.	Raiser's Name.	Colour.
1	1	6	Madame Gabriel Luizet ... ..	1877	Liahaud ... ..	Light silvery pink
2	16	49	Ulrich Brunner ... ..	1881	Levet ... ..	Cherry red
3	2	3	A. K. Williams ... ..	1877	Schwartz ... ..	Bright carmine red
4	9	19	Merveille de Lyon ... ..	1882	Pernet ... ..	White
5	2	13	Marie Rady ... ..	1865	Fontaine ... ..	Bright carmine red
6	4	10	François Michelon ... ..	1871	Levet ... ..	Deep rose
7	2	2	Marie Baumann ... ..	1863	Baumann ... ..	Soft carmine red
7	3	1	La France ... ..	1867	J. B. Guillot fils ... ..	Silvery rose
7	10	51	Marie Cointet ... ..	1872	J. B. Guillot fils ... ..	Light pink
7	12	5	Marquise de Castellane ... ..	1869	Pernet ... ..	Clear cherry rose
8	6	96	Lady Mary Fitzwilliam ... ..	1882	Bennett ... ..	Light rosy pink
9	10	21	Duchesse de Vallomhrosa ... ..	1875	Schwartz ... ..	Pale rosy flesh
10	15	4	Baroness Rothschild ... ..	1867	Pernet ... ..	Light pink
10	14	11	Erienne Levet ... ..	1871	Levet ... ..	Carmine rose
11	5	45	Monsieur Noman ... ..	1866	Guillot père ... ..	Pale rosy pink
12	13	9	Alfred Colomb ... ..	1865	Lacharme ... ..	Bright carmine red
12	17	14	Louis Van Houtte ... ..	1869	Lacharme ... ..	Deep crimson maroon
12	9	34	Xavier Olibo ... ..	1864	Lacharme ... ..	Dark velvety crimson
13	14	38	Abel Carrière ... ..	1875	E. Verdier ... ..	Crimson maroon
14	7	7	Charles Lefebvre ... ..	1861	Lacharme ... ..	Purplish crimson
14	11	33	Le Havre ... ..	1871	Eude ... ..	Vermilion red
15	10	27	Beauty of Waltham ... ..	1862	W. Paul & Son ... ..	Rosy crimson
15	0	0	Her Majesty ... ..	1886	H. Bennett ... ..	Light pink
16	13	—	Marie Finger ... ..	1873	Raimbaud ... ..	Light salmon rose
16	12	47	Prince Arthur ... ..	1875	Cant ... ..	Bright crimson
17	19	25	Marie Verdier ... ..	1877	E. Verdier ... ..	Pure rose
17	19	36	Star of Waltham ... ..	1875	W. Paul & Son ... ..	Carmine violet
18	13	0	Violette Bouyer ... ..	1881	Lacharme ... ..	Tinted white
19	12	28	Duke of Wellington ... ..	1864	Granger... ..	Vivid crimson
19	16	26	Fisher Holmes ... ..	1865	E. Verdier ... ..	Shaded crimson scarlet
19	16	—	Ferdinand de Lesseps ... ..	1869	E. Verdier ... ..	Shaded crimson
20	0	35	Comtesse de Serenye ... ..	1874	Lacharme ... ..	Very pale rose, shaded
20	18	18	Comtesse d'Oxford ... ..	1869	Guillot père ... ..	Carmine violet
20	0	0	Dr. Sewell ... ..	1879	Turner ... ..	Crimson scarlet
20	12	12	Duke of Edinburgh ... ..	1868	Paul & Son ... ..	Scarlet crimson
20	10	22	Horace Vernet ... ..	1866	J. B. Guillot fils ... ..	Purplish crimson, shaded
21	17	58	Annie Laxton ... ..	1872	Laxton ... ..	Clear rose
21	8	31	Camille Bernardin ... ..	1865	Gautreau ... ..	Light crimson
21	21	48	Duke of Teck ... ..	1880	Paul & Son ... ..	Crimson scarlet
21	0	53	Madame Eugène Verdier ... ..	1878	E. Verdier ... ..	Light silvery rose
21	13	16	Marguerite de St. Amand ... ..	1864	Sansal ... ..	Clear rosy flesh
22	20	15	Dr. Andry ... ..	1864	E. Verdier ... ..	Bright crimson
22	21	55	Duchess of Bedford ... ..	1879	Postans... ..	Light scarlet crimson
22	18	32	Dupuy Jamain ... ..	1868	Jamain ... ..	Bright cerise
22	15	23	Madame Lacharme ... ..	1872	Lacharme ... ..	Nearly white
22	16	60	Reynolds Hole ... ..	1873	Paul & Son ... ..	Deep scarlet maroon
23	0	65	A. Dumesnil ... ..	1879	Margottin fils ... ..	Light crimson rose
23	0	0	Alphonse Soupert ... ..	1883	Lacharme ... ..	Pure bright rose
23	3	8	Captain Christy ... ..	1873	Lacharme ... ..	Delicate flesh
23	16	44	Countess of Rosebery ... ..	1879	Postans... ..	Carmine rose
23	20	17	E. Y. Teas ... ..	1874	E. Verdier ... ..	Bright carmine red
24	22	0	Comte Raimbaud ... ..	1867	Rolland ... ..	Clear crimson
24	15	86	Heinrich Schultheis ... ..	1882	Bennett ... ..	Delicate pink rose
24	20	67	Lord Macaulay ... ..	1863	W. Paul & Son... ..	Bright crimson, shaded
24	0	87	Madame Prosper Laugier ... ..	1875	E. Verdier ... ..	Light carmine rose
24	22	0	Queen of Queens ... ..	1883	W. Paul & Son... ..	Pale bluish pink
24	21	0	Rosicriste Jacobs ... ..	1880	Ducher ... ..	Dark velvety red
25	20	64	Charles Darwin ... ..	1879	Laxton ... ..	Brownish crimson
25	0	90	Henri Ledechaux ... ..	1868	Ledechaux ... ..	Clear cherry red
25	0	0	Jules Finger ... ..	1879	Lacharme ... ..	Pale soft peach
25	22	0	Magna Charta ... ..	1876	W. Paul & Son... ..	Bright pink carmine
25	21	29	Pride of Waltham ... ..	1881	W. Paul & Son... ..	Light salmon pink
26	0	0	Eugène Fürst ... ..	1875	Soupert et Notting ... ..	Crimson shaded purple
26	19	41	Général Jacqueminot ... ..	1853	Rousselet ... ..	Bright scarlet crimson
26	21	68	John Stuart Mill ... ..	1875	Turner ... ..	Bright rosy crimson
26	15	20	Madame Hippolyte Jamain... ..	1871	Jamain ... ..	Pale flesh
26	19	30	Sénateur Vaisse ... ..	1859	Guillot père ... ..	Bright crimson
26	0	0	Victor Hugo ... ..	1884	Schwartz ... ..	Bright crimson, shaded

TEAS AND NOISETTES.

Position in Present Analysis.	Position in 1886 Analysis.	Position in 1884 Analysis.	Name of Rose.	Date of Introduction.	Raiser's Name.	Colour.
1	3	3	Catherine Mermet ... ..	1869	J. B. Guillot fils ...	Light rosy flesh
2	2	2	Maréchal Niel ... ..	1864	Pradel ... ..	Deep golden yellow
3	7	12	Comtesse de Nadaillac ... ..	1871	J. B. Guillot fils ...	Rosy flesh and apricot
4	4	3	Innocente Pirola ... ..	1878	Madame Ducher ...	White, slightly shaded
5	5	5	Niphotos ... ..	1844	Bougère... ..	White
6	1	10	Caroline Kuster ... ..	1872	Pernet ... ..	Lemon yellow
7	3	6	Souvenir d'Elise Vardon ... ..	1854	Marest ... ..	Yellowish rosy cream
8	7	1	Souvenir d'un Ami ... ..	1846	Belot-Defougère ...	Pale rose
9	16	0	Madame de Watteville ... ..	1883	Guillot ... ..	Pale lemon, pink margin
10	8	16	Etoile de Lyon... ..	1831	Guillot ... ..	Bright sulphur yellow
11	3	7	Jean Ducher ... ..	1874	Madame Ducher ...	Salmon yellow, shaded peach
11	10	26	Madame Cusin... ..	1881	Guillot fils ... ..	Violet rose
12	6	4	Marie Van Houtte ... ..	1871	Ducher ... ..	Yellowish white tinted rose
12	13	0	Hon. E. Gifford ... ..	1882	Guillot ... ..	Blush white tinted pale rose
13	11	25	La Boule d'Or .. ..	1860	Margottin ... ..	Golden yellow
14	17	22	Madame Margottin ... ..	1866	J. B. Guillot fils ...	Citron yellow
15	9	15	Anna Ollivier ... ..	1872	Ducher ... ..	Pale rosy flesh shaded buff
16	12	—	Madame Bravy ... ..	1848	Guillot père ... ..	White flushed pale pink
16	13	14	Madame Willermoz ... ..	1845	Lacharme ... ..	Creamy white
16	14	0	Princess of Wales ... ..	1882	Bennett ... ..	Pale rosy yellow
17	15	38	Madame Hippolyte Jamain... ..	1869	J. B. Guillot fils ...	White, shaded yellow
18	0	0	Madame Angèle Jacquier ... ..	1879	J. B. Guillot fils ...	Light pink, shaded yellow
18	9	13	Souvenir de Paul Neyron ... ..	1871	Levet ... ..	Creamy white, tinted rose
19	18	20	Belle Lyonnaise ... ..	1869	Levet ... ..	Deep lemon
19	18	24	Madame Welche ... ..	1878	Ducher ... ..	Pale yellow, flushed pink
20	15	9	Devoniensis ... ..	1838	Foster ... ..	Creamy white
20	20	0	Francisca Kruger ... ..	1879	Nabonnand ... ..	Coppery yellow, shaded rose
20	19	18	Perle des Jardins ... ..	1874	Levet ... ..	Bright straw colour
21	20	29	Jules Finger ... ..	1879	Madame Ducher ...	Rose shaded silver
21	0	0	Moiré ... ..	1844	Moiré ... ..	Rosy fawn
22	0	0	Homère ... ..	1859	Moreau-Robert ...	Rose edge, light base
23	0	0	Marcelin Rhoda ... ..	1872	Ducher ... ..	Yellow
23	0	0	Marquise de Samina ... ..	1875	Madame Ducher ...	Coppery rose
23	12	11	Rubens ... ..	1859	Robert ... ..	Creamy white

As this is the best time of year in which to order Roses for planting in November, a selection of a few high-class varieties which can be recommended for general cultivation, will, no doubt, prove acceptable to those of your readers who, although not exhibitors, may nevertheless wish to grow only the choicer kinds.

**HYBRID PERPETUALS.** — *Light-coloured varieties.* — Baroness Rothschild, Captain Christy, Her Majesty, La France, Madame Gabriel Luizet, Marie Finger, and Merveille de Lyon.

*Medium Reds.* — Comtesse d'Oxford, Dupuy Jamain, Heinrich Schultheis, Marie Verdier, Marquise de Castellane, and Ulrich Brunner.

*Reds.* — Alfred Colomb, A. K. Williams, Camille Bernardin, Dr. Andry, E. Y. Teas, Ferdinand de Lesseps, Marie Baumann, and Prince Arthur.

*Dark Varieties.* — Charles Lefebvre, Duke of Wellington, Horace Vernet, and Louis Van Houtte.

*Teas and Noisettes.* — Anna Ollivier, Caroline Kuster (N.), Hon. Edith Gifford, Innocente Pirola, Madame de Watteville, Madame Lambard, Marie Van Houtte, Perle des Jardins, and Souvenir d'un Ami.

*Bourbon.* — Souvenir de la Malmaison.

My best thanks are due to Mr. J. Burrell, Rev. F. H. Gall, Mr. W. J. Jefferies, Mr. G. Mount, Mr. J. Sargant, and Mr. R. E. West for their kind assistance in taking down the names of so many of the Roses in the winning stands; also to Mr. T. W. Girdlestone for supplying the dates and raisers' names of those varieties which did not find places in either of the previous analyses. — E. M., *Berkhamsted.*

MELON RAISING.

I AM heartily tired of certificated Melons, and the Royal Horticultural Society's Fruit Committee have at last discovered the fact that many shown are not improvements on existing varieties. Had the standard been Egyptian for the round, and Persian-Cashmere for oval, I very much question if we should have been bothered with such a mass of Melons. They come thicker and faster every year, and get worse. If the Royal Horticultural Society took the matter in hand in good earnest we might hope for the future of the Melon. There need be no higher standard of excellence than Cantaloupe, Persian, and Egyptian. The

Cabul and Cashmere are only varieties of the Persian. Those mark the type of Melons—ribs with a narrow suture, Cantaloupe; ribs with a wide suture or flat parting between the ribs, Egyptian; smooth, without ribs or suture, Persian. Netting is characteristic of the Egyptian and Persian, but not of the Cantaloupe, which is more inclined to wart or carbuncle. The other characteristics are the Egyptian and Cantaloupe are not keepers, but the Cantaloupe is better in that respect than Egyptian. The Persian is an excellent keeper, and on that account very desirable. The Cantaloupe is early, Egyptian medium, and Persian late. Coulommier's can hardly be considered a distinct type, but the Rock is decidedly so, and so also is the Winter or Valentia. The Cantaloupe is supposed to be the first Melon cultivated in Europe. A century back there were several varieties—viz., Early Cantaloupe, Carbuncled, White, Orange, and Rock, the Black Rock being distinguished from the other kinds of Cantaloupe on account probably of its dark rind and great size. There were also the ribbed, netted Melon, which is undoubtedly the type of all the embroided Melons—viz., Egyptian; and the smooth green (Persian) and green-fleshed (Italian), perhaps a cross between Cantaloupe and Egyptian. The yellow Ispahan Melon is of later date. The Persian Melon is sometimes yellow marbled with dark green, which is manifestly a hybrid or cross breed between the green and yellow forms of Persian. Of the Persian type are the Cabul and Cashmere Melons, both with netted yellow rinds and whitish flesh.

Of the Cantaloupe we have not any nearer forms in the present or even recent varieties than Cirencester Prize, a mixture of Cantaloupe with Black Rock and Duke of Edinburgh, a compound of Coulommiers—an oval Cantaloupe—with Winter or Valentia. Little Heath is unmistakably a cross between Cantaloupe (early) and Egyptian, the rind netting, and ribs being Egyptian, whilst the flesh and long-keeping properties are Cantaloupe. Bromham Hall is a marked example of the early Cantaloupe, in which the green flesh and high quality of the Egyptian is implanted, and the forerunner of the Victory of Bath section, which attained to great perfection by judicious crossing and careful selection in the skilful hands of Mr. Gilbert of Burghley Gardens. Anterior to this the late Mr. Bailey did much in improving the size of Egyptian. His Mrs. Bailey was a standard variety in my 'prentice days, and it is remarkable that in his hands it (Egyptian) took the oval form. The Squire and Victory of Bath also became decidedly oval with Mr. Gilbert. All effort at size have been with round sorts subjected to high cultivation in the direction of the oval form. Heckfield Hybrid and Queen Emma are a mixture of the oval Cantaloupe overcome by the preponderance of the Persian pollen. Precisely the same occurs with Golden Gem, only the embroided Egyptian is made to lose its ribs, skin, and flesh by the strong influence of Cashmere. Scarlet Gem is a



Cantaloupe flesh implanted in the rind of Pineapple, a greyish coloured form of Egyptian, of American origin.

The only other form of Melon leading up to our present advanced forms that need be taken into account is Beechwood, a green fleshed, netted, highly flavoured fruit, originally from Persia. This is the only one of the older types that affords two distinct shapes from seed of the same fruit. The original as I take it was oval exclusively, netted, but I have noticed that it developed by entivation in the best examples into a round fruit, and the seedlings from it were of two forms—viz., oval, somewhat quartered and irregular in outline, little and coarsely netted, which I consider the type from which sprang Eastnor Castle; and the other round, very finely netted, with a somewhat firm yet melting and highly flavoured flesh, which I consider the type from which sprang the round and bluntly oval kinds with highly or regularly laced and even—i.e., not ribbed surfaces. Meredith's Cashmere has contributed very little to our present race of Melons, except in one notable instance, which will be alluded to presently, its slight ribs and moderate netting not being traceable in any except Golden Gem.

There is no kind of fruit amongst which cross-fertilisation is naturally or artificially so readily effected and new varieties produced than amongst Melons. The improvement extends but a few seasons beyond that of origination, and that chiefly from discontinuance of cross-fertilisation of the individual kind, and less care in selection. Cross-fertilisation is culturally very desirable for the attainment of high quality; but it is one thing cross-fertilising with a view to enhancing the value of the current crop, and another altogether when the aim is seed for continuing the variety, and no regard is had to the descent of the parents. Crossing with any kind at hand, and for the mere sake of the thing, is more likely to further deterioration than improvement; in fact, monogrels result that discredit the raiser and grower and disgust the consumer. Not that new varieties surpassing the old may not be obtained by random crossing, but it is all chance. Some have points of great excellence. Those should be retained whereby to test new ones, consequently maintaining a high standard. Of that class are Blenheim Orange and Benham Beauty of the early or Cantaloupe type, which, though having an Egyptian exterior, are in flesh decidedly Cantaloupe. William Tillery may be taken as the nearest to the high quality of the Egyptian. Of the mixed types and without ribs but finely or beautifully netted, the white lacing on the yellow ground of some being exquisite are Best of All, Hero of Lockinge, and Colston Bassett. Of Persian, Meredith's Cashmere; of the Bromham Hall type, Gilbert's Victory of Bath. Eastnor Castle may be taken as representative of the Beechwood, and Golden Gem of the mixed race, in which the flesh of the Persian is implanted.

There is perhaps as good or even better varieties than those named. Every raiser of course will have a pet. I have had no end of them; indeed, have some pedigree sorts which are an amalgamation of most sorts sent out up to 1885, and in the seed packets where they are likely to remain, for if anyone wants a monogrel lot of Melons, variety with and without merit, I can strongly advise in-and-in-breeding, and as safely point to distinct and high quality sorts only being secured by judicious crossing and painstaking selection along with comparison with standard high-class kinds. I may give an example in Melon crossing, and premise that Beechwood in the round, not ribbed, but highly netted form, was crossed with Read's Scarlet-flesh, which resulted in two forms, a green and scarlet flesh; the first good in flavour, the latter poor. The green-flesh was selected and named North Durham, which was crossed with Victory of Bath. That gave a green-flesh, round sparingly netted fruit, very heavy, but not particularly rich. It was named North York. That I crossed with William Tillery, and procured an oval, also a round-fruited variety. Both were very inconstant; the oval would give both forms, and the round likewise. The fruit in either case was ribbed with a wide suture in the young state, green in colour with grey in the suture, but the ripe fruit showed very little of the ribs or suture, being in well-grown examples rotund in outline, and very much and evenly netted, flesh green, very rich, even to cloyishness. By careful selection the fruit has become round and the deviations are very bluntly oval. It is early and a good late variety, also an excellent summer variety in frames. I have named it J. Wright, as complimentary to a connoisseur of Melons.

Beechwood × Victory of Bath resulted in Eastnor Castle by Mr. Coleman, which gave two forms—a round or very bluntly oval well-netted fruit, and an oval, slightly ribbed, and sparsely and irregularly netted fruit. The first is a very fine fruit indeed, with a thick, melting, rich, green flesh; the second is a coarse fruit, with plenty of coarse flesh, which soon parts with its sweetness. The latter form is not worth growing, and the first is only continued by very careful selection. Eastnor Castle variations gave rise to Earl of Beaconsfield, and Dell's. I omit the "hybrid" as there is not a particle of that in any of them, the materials being cross-breeds. Now I must offer some remarks on Hybrid Cashmere (Meredith's), which I take to be a cross bred between Isphahan and Keising, the former being late, and the latter a rather early netted variety. Perhaps some correspondent can give precise information on this point. Cashmere (Meredith's) is oval, slightly ribbed (lost in highly developed examples), yellow, flesh white. It is slightly netted, it being very fine or small. When well grown it has not, perhaps, any rival for delicacy, juiciness, and excellency of flavour. It is an old variety, but not so old as Beechwood, both of Persian origin. I mention those particulars, for we come to something very remarkable in crossing, as presented in Longleat Perfection. Mr. W. Taylor brought Cashmere to great perfection at Longleat by high culture, and no doubt careful selection. There is no question of

Eastnor Castle being equally well cared for by Mr. Pratt, both as regards cultivation and selection. We have seen Beechwood × Victory of Bath result in Eastnor Castle's variable forms, and Eastnor Castle crossed with Meredith's Cashmere gave Longleat Perfection, which is of two forms—one very bluntly oval, and pointed oval. The bluntly oval is ribbed, with a wide well defined suture; the pointed oval is also ribbed with a small suture, and is evidently after the coarse form of Eastnor Castle before alluded to, and though a large is not nearly so desirable a form as the other. When swelling the bluntly oval fruit is green on the ribs, turning grey toward the suture, which is quite grey, almost silvery, and handsome; indeed the greyness in the young fruit is characteristic of high quality in the mature—instance, Egyptian and Pineapple, but when ripe the ribs are a lovely yellow, and the suture is, as it might appear, a strip of lovelier green marking the divisions, giving a handsome appearance. It is smooth skinned, very thin, flesh thick, white, delicate, highly melting, very juicy, luscious, in every respect exquisite. The plant is of excellent constitution, and it is a free setter, good alike for house or frame culture.

Scarlet Premier has an unmistakable Persian skin, with the close netting of the Cashmere, bluntly oval, very even in surface, and remarkably handsome, being of a deep yellow or orange colour. The flesh is scarlet and as rich as Scarlet Gem. I do not know anything of the origin of this superb fruit, only that it was originated by the very successful fruit grower and exhibitor, especially Melons, Mr. McIndoe, than whom I know none more skilled and experienced, and who will perhaps enlighten us. Scarlet Premier's aroma is exquisite.

Those three—J. Wright, Longleat Perfection, and Scarlet Premier—are my selections for future work. The two last have very valuable properties—viz., beauty, quality, and, best of all, keeping. Longleat will keep a fortnight and Scarlet Premier three weeks without any deterioration of quality, only they must of course be cut before they are fully ripe, or rather under, allowing them to come on in a cool fruit room.

Last year Mr. Easty wrote flatteringly of a variety of my raising—viz., W. Iggulden or Earl of Beaconsfield × North Durham (Beechwood × Read's), a round, ribbed, deep sutured, netted, green-fleshed fruit, in all points except flesh corresponding to Little Heath, keeping well, and likely to prove a good market fruit. If Mr. Easty has the variety answering to the above description I should be glad to exchange a few seeds of it for J. Wright through the Editor.

I request leave in conclusion to ask raisers of Melons not to be angered at anything advanced, which is purely my impression in respect of varieties as I have found them, and not biased by any motive other than to see a departure from the stereotyped forms that at present obtain through in-and-in crossing, and to, if possible, make the standard higher, thereby closing the door against those with nothing to recommend them save their variableness and deteriorating tendency.—G. ABBEY.

#### A JUBILEE CARPET BED.

If it be not yet too late to speak of the Jubilee, I think your readers may be pleased to have a description of one of the most unique and effective horticultural mementos of this kind we have seen, and which is just now in full beauty in the terrace gardens at the very beautiful seat of Mrs. Pike at Besborough, Co. Cork.

This dainty little piece of garden painting is in the form of a parterre picked out in the grass, showing a rectangular bed of some 16 feet in length by about 6 feet in width. By a judicious selection and careful planting in their proper season of sundry dwarf-growing flower and foliage plants, it is so arranged as to present to the eye a device containing the British Ensign in duplicate, the two dates commemorated, the Queen's cypher, and a Crown. The enclosed sketch (fig. 31) may serve to give an idea of its peculiar attractions. It must be seen to be fully appreciated. It may, however, further help to realise the effect produced if I give the following particulars:—

It is fringed with an 8-inch border of *Sedum glaucum*; the principal space is filled in with a dark green ground of *Herniaria glabra*. In this ground are laid out crosswise the representations of the British flag. The staff is lined out with *Alternanthera paronychioides aurea*, and the ensign itself with *Alternanthera magnifica*, with a ground of *Antennaria tomentosa*, picked out in the small diamonds with *Kleinia repens*. Between the two ensigns on the upper side is the Crown in the centre marked out with *Spergula pilifera aurea* and emblazoned or jewelled with *Lobelia pumila magnifica*. On either side the Crown are the dates 1837 and 1887 formed of the little dwarf *Arabis lucida variegata*, the initials V. R. being outlined with *Alternanthera magnifica*; the whole forming a *tout ensemble* of a singularly charming character, and reflecting very great credit on the professional skill of the painstaking and accomplished gardener at Besborough, Mr. Beswick.

It would have given additional interest in the *Journal of Horticulture* if I had been able to make a fuller allusion to the various features of the gardens and grounds under his care. Suffice it to say the vineries are in almost perfect condition, one of them representing a splendid show of

some 1200 to 1400 healthy full-formed bunches of Royal Muscadine, Black Hamburgh, Chasselas Musqué, and other varieties. The Pine Apples are in fine condition, and already show prospect of plentiful crop, Queens, Smooth Cayennes, Prince Albert, and some others being conspicuous.

Walking over the grounds many attractions meet the eye, not the least of these being an avenue of fine free-growing Araucarias, and a long walk planted on each side with sundry varieties of forest trees of graceful form, greatly admired by visitors, and in the planting and cultivation of which the taste of the late lamented proprietor, E. Pike, Esq., is everywhere visible. Sparing no pains or cost in attaining the object in view, the most casual observer, as he leisurely strolls through the place, must be struck with the success attained.—VISITOR.

**GOOD PLUMS.**

IN my opinion there is no hardy dessert fruit more pleasing than a good Plum. The form and colour of some varieties are very attractive, and the beautiful bloom they acquire gives one a good impression of their richness. The flavour of the good varieties is excellent, and it is a little surprising that Plums are not more grown, especially in small gardens. I know many instances where considerable attention is given to Peaches, Nectarines, and Apricots in the open, and the result almost invariably is failure, or very near it, as the fruits are uncertain in numbers, and not always well flavoured, but Plums will root freely at least two seasons out of every three, and their development and flavour is, as a rule, very satisfactory, and very often thoroughly so. If the

**SOME NEGLECTED PLANTS.**

To a great extent fashion is to blame for the neglect of old favourites. We have only to take a glance through any private establishment, either of small or large proportions, and the cry on every hand is, "Our people want such an amount of cut flowers now-a-days that we can hardly keep pace with them;" and so it is the occupants of our greenhouses and stoves of years ago were not in a great majority of instances adapted for the cut-and-come-again practice of to-day. The order of to-day is something that may be forced easily and which will yield an abundance of bloom readily. Thus it is that the mixed collections of plants so frequent in greenhouses of the past have given way to a more limited number of useful plants for the purpose named. But notwithstanding this great change and the number of really good plants which have been sacrificed in consequence, there is no reason why such should be quite lost sight of, and therefore a passing reminder of some may not be altogether useless.

**DIPLADENIAS.**

First, then, we will briefly consider one of the most lovely of stove climbers, I mean the Dipladenias, and we cannot but wonder why these plants are not seen more frequently on the roofs of our warmer plant houses. True it is that as specimens on trellises we sometimes see them at the leading exhibitions, and even here not nearly so frequently as their merits deserve. It is not going too far to say of them that they are not equalled by any other stove climber, their gaily coloured trumpet-shaped blossoms are almost

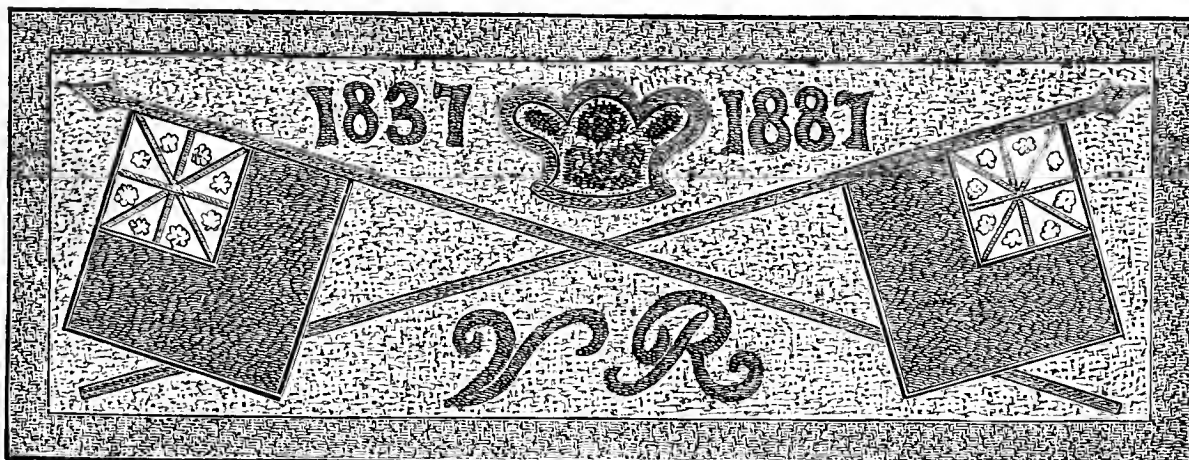

Fig 31.—A JUBILEE CARPET BED.

same attention were given to protecting Plum blossom and growing the trees as is devoted to the Peach trees, the Plum results would be grand, and if those who have tried time after time to secure a crop of good Peaches, but never succeeded, would root their trees out and introduce good Plums, I am sure they would be satisfied with their work. Perhaps some may not be able to decide to root out a Peach tree, as "it is such a fine specimen," but although specimen foliage plants are very pretty indoors, Peaches and Apricots, with little else but their wood and foliage to recommend them, are not valuable, and no one need hesitate to root them out if there is a sure prospect of securing a good crop of Plums in their stead.

A rather heavy calcareous soil always suits them, and good drainage is an advantage which should never be lost sight of. Very free bearing sorts are to be commended. Some may think that those which bear heavily and annually cannot be very good, but this is a mistake. There is not a more prolific Plum in cultivation than the Victoria; it succeeds as a bush, and excels on a wall, grows to a large size, colours brightly, and when well grown is undoubtedly excellent. It is much valued for preserving, and is equally acceptable as dessert. Kirke's Plum is generally described as being "medium size, round, deep purple, juicy, sugary, delicious, one of the finest dessert Plums," and merits every word of this description. The Green Gage Plum may be reckoned amongst hardy fruits at the same high standard as Muscat of Alexandria is amongst Grapes. It is almost unique amongst high-flavoured fruits. Coe's Golden Drop is another grand Plum, and the dark purple De Montfort is excellent. Rivers' Early Favourite should be planted everywhere, as it is ready before all others, and Rivers' Early Prolific is equally good, and, if anything, more prolific than the last named. As a September Plum Jefferson's is hard to surpass. It is large, oval, golden yellow, mottled with red, and deliciously flavoured. Reine Claude Violette is very high flavoured, but not very prolific, and the following are other good sorts—Purple Gage, Ickworth Impératrice, Lawson's Golden, Washington, and Prince of Wales.—M.

unique. They are best treated as pot plants perhaps where their wants may receive annual attention. Some growers manage these plants remarkably well in pots, and certainly well-grown examples are highly creditable, since they require considerable experience to bring them to perfection. The white flowered *D. boliviensis* is much more robust than the coloured species, and is at the same time very useful. In the Royal Exotic Nurseries, Birmingham, Mr. Spinks, the manager, has a noble example planted out in one of the stoves. It makes remarkable growth and produces great numbers of flowers. By gradually ripening the shoots in the autumn by exposure to sun and giving the plants a complete rest during the winter months good flowering wood is guaranteed for the succeeding year. They should be potted early in spring and lightly syringed once or twice a day according to circumstances, and by being afforded plenty of heat they will soon be in active growth, and those thus treated will produce abundance of flowers during the summer and autumn months. Roughly chopped peat and charcoal with plenty of sand is a good compost for them, and a perfect drainage is of the highest importance. Careful watering at all times is needful to keep them in health, for if once the soil becomes overcharged with water—it will soon be seen by the leaves turning yellow—the chances are against it unless it be in experienced hands. The whole of this group are deserving of much care and attention, for they are among the most beautiful of stove climbers.

**GLORIOSAS.**

The Gloriosas are another instance of neglect, and as in the last case are very attractive stove climbing plants. Of one species at least this may be said with much truth—namely, *G. superba*. It may be grown in an intermediate temperature, or even in a green-

house. A plant I had some years ago was trained close to the glass, running lengthways of the house, and it grew and flowered freely. Plants in both stove and greenhouse temperatures flowered with the same freedom, though of course not at the same time. To grow *Gloriosas* successfully, great attention must be paid to ripening the bulbs. This is absolutely necessary both to ensure free flowering in the ensuing year and also for the preserving of the bulbs during winter. In whatever temperature our plants were grown a slow and gradual ripening was given them, the benefit derived from such treatment being year by year apparent.

Another point which was always adhered to was starting the plants early into growth—namely, about the middle of February, plunging them in gentle bottom heat. When properly matured—that is, when leaf and stem are turned yellow, they may be left without water for a month, after which turn them out and place in dry sand, or allow them to occupy their pots in some warm dry corner in the stove, but away from the pipes. They keep well in sand, however, and require no water for three or even four months. The earliest started will flower in the end of June and continue for a considerable time. With this treatment *Gloriosas*, or *Methonicas* as they are sometimes called, are by no means difficult to grow. They delight in a mixture of peat and loam in equal parts, with a liberal addition of sharp sand and cow manure at the rate of one-fifth of the whole. When growing it requires abundance of root room, and serial shifts should be avoided. Some years ago an old friend assured me that these plants were hardy in favoured localities and protected in winter, but I have not yet had the courage to test the veracity of the statement.—J. H. E.



MESSRS. J. CARTER & Co., High Holborn, send us a remarkable BUNCH OF PERFECTION TOMATOES grown out of doors near Bexley. The bunch contained eleven fruits, and had originally a dozen, one having fallen. The eleven fruits weighed 2 lbs. 9 ozs., good even well ripened specimens, an unusual example of successful culture. It has, however, been an exceptionally favourable season for Tomatoes out of doors.

— WE understand that the Autumn Show of the RICHMOND HORTICULTURAL SOCIETY will not be held this year, owing, it is said, to a disinclination on the part of the Committee to appeal to the subscribers, whose purses have been heavily taxed by local Jubilee demands.

— "E. M." writes:—"The GOLDEN ELDER requires free exposure to the sun to bring out its beautiful golden colour properly, and as such it is a striking object in the shrubberies when associated with other suitable shrubs or trees. The Purple Hazel is a capital companion to it. A delightful contrast is formed when the two shrubs are planted side by side in a clump of say half a dozen plants each. This season the sun has been too powerful for the Elder, and all the uppermost leaves are burnt and shrivelled. Any time during the winter the shoots should be pruned in to one or two eyes on each stem, whence the young growth springs and grows from 4 to 5 feet long in one season."

— IN the report of the BATH SHOW we omitted to mention that Mr. G. Lock, gardener to B. W. Cleave, Esq., Crediton, and Mr. A. Miller, Rood Ashton, Trowbridge, were respectively first and second for Pine Apples, both having handsome fruits of Smooth Cayenne.

— "AT a RED CABBAGE AND CELERY SHOW held at the Hadfield Hotel, Barber Road, Sheffield, on Saturday afternoon last," says "W. K. W.," "the weight of the heaviest and best Cabbage was 20 lbs., the best brace of Celery turning the scale at 7 lbs.; the latter was well bleached and of excellent quality. The Cabbage also was of high colour, closely trimmed, and of first-class quality. There were about thirty entries in each class, the quality being good throughout. Six Onions shown, 'not for competition,' weighed 8 $\frac{3}{4}$  lbs, the variety being Giant Rocca, and the size equal to the largest imported Spanish Onions. When we consider that the above are the produce of cottage growers, most of whom are engaged in the cutlery or file trades during the day, and considering the exceptionally hot and dry season we have

experienced, with the consequent difficulty and greatly increased labour in the production of such vegetables, we can readily appreciate the industry expended upon them."

— THE WAKEFIELD PAXTON SOCIETY.—At a meeting of the members of the above Society held at the "Saw Hotel," Mr. W. Hudson, gardener at Sandal Grange, presided, and Mr. B. Whitley was in the vice-chair. The essayist was Mr. S. Ballinger, gardener, Barnsley, and he read a well-prepared and thoroughly practical paper, entitled "How to Secure a Good Crop of Carrots." Mr. Ballinger alluded to the value of the Carrot as food for man, pointed to some of the difficulties which have been experienced in cultivating it in this country, and explained how he had overcome them and secured a good general crop. He said the Carrot prefers a firm but poor soil, the admixture of a large quantity of manure tending to cause the roots to be destroyed by grubs or maggots, which penetrate the soil if it is not trod firmly. A short discussion followed the reading of the paper, in which Messrs. Pye, Preston, and Garnett took part, and put questions to the essayist, which he clearly and promptly answered. On the motion of Mr. Brown, gardener at Hatfield Hall, seconded by Mr. J. W. Simpson, of Walton, a hearty vote of thanks was accorded to Mr. Ballinger, who also replied to questions asked by the proposer and seconder of the motion.

— MR. JAS. WICKETTS, Whitcroft, Pershore, writes:—"On Saturday last about half-past three in the afternoon we had a great SWARM OF LADYBIRDS, thousands upon thousands. Our house was being painted, and, I am sorry to say, many were caught by the wet paint when they arrived, and also when they left. We could distinctly hear the noise of their flight. Is it usual for them to move in such large numbers? Have they been seen elsewhere?"

— THE usual monthly meeting of the BELGIAN HORTICULTURISTS was held in Ghent, September 13th, when the following members were present:—MM. V. Cuvelier, François Desbois, De Smet-Duvivier, Jules Decock, Jules Hye-Leyden, Charles Van Geert of Antwerp, A. Rosseel, Halkin of Brussels, Raph. De Smet, and Ernest Delaruye. M. Charles Spae presiding, and M. Emile de Cock being Secretary. Certificates of merit were awarded for *Pteris Bausei* from M. De Smet-Duvivier; *Oncidium barbatum* from M. A. Van Imschoot; *Cattleya Gaskelliana* from MM. Vervaet et Cie; *Odontoglossum Vervaeti* from the same; and *Lobelia erinoides alba flora grandiflora* from M. Devriesere-Reemens. Cultural certificates were awarded for *Glazioua insignis*, from M. Auguste Van Geert; *Oncidium incurvum*, from MM. Vervaet et Cie; and *Epidendrum raniferum* from M. A. Van Imschoot.

— A GARDENER in the provinces writes:—"I wish to thank the Assistant-Secretary (Mr. E. Bax) for the information he has tendered (page 203) respecting the ROYAL HORTICULTURAL SOCIETY'S PUBLICATIONS. In my letter on page 191 the word 'Fellows' was inadvertently employed instead of the 'public.' The sentence should have read 'Offering the report of the Pear Congress to the public is a new departure on the part of the Council of the Royal.' I was aware that the reports when issued were circulated amongst the Fellows of the Society, but the announcement in this Journal that the report of the Pear Congress could be had by outsiders was the first intimation that I have seen that the reports could be had by others than the Fellows. I am glad to find, however, that the report of the Primula Conference can be had. I have asked more than one Fellow of the Society whether this particular report could be had, and they appeared to possess no knowledge on the subject."

— THE usual fortnightly meeting of the WALKLEY (Sheffield) AMATEUR FLORAL AND HORTICULTURAL SOCIETY was held on Friday evening last at the "Howard Hotel," Walkley, when there was a large attendance of members, Mr. Thos. B. Hague (President) in the chair. The exhibition by members of plants, fruit, and cut flowers was one of the most extensive and best ever held by the Society, four large tables being well filled by exhibits, most of them of a very high order of excellence. Mr. Hague, the President, exhibited a very fine group of Cactus and Pompon Dahlias, also fine stands of Roses, Asters, show Dahlias, Pansies, and Phloxes. Amongst the Roses was one of the best exhibition blooms we have seen this year, the variety being *Mdlle. Annie Wood*, a fine autumn bloomer. Mr. Marson showed an especially fine *Lilium auratum* with three strong stems and twenty-seven blooms all from one bulb, an imported one, purchased in the spring at a cost of eightpence. Mr. Jarvis, the Hon. Sec., showed very fine *Lilium lanc*



folium, rubrum, and roscum as pot plants, and cut flowers; Mr. Tingle a fine collection of Pansies; Mr. F. Barnes excellent specimen Ferns, Gloxinias, and a beautiful stand of stove and greenhouse cut flowers. Mr. Woodcock showed, not for competition, a fine collection of early flowering Chrysanthemums. The discussion following the judging upon the modes of culture practised by the successful exhibitors of the principal subjects shown was very instructive.

— ZONAL PELARGONIUMS AT BRISTOL.—At Messrs. Garaway's Durdham Down Nurseries, Clifton, there is generally an instructive display of popular plants, and recently a fine bank of Zonal Pelargoniums has come in for a good share of attention. This fine group was margined by about 300 neat, beautifully flowered plants, of the double white *Le Cygne*, a variety excellent in nearly every respect, though scarcely so good for winter flowering as we expected. Other good doubles were *Bac Ninh*, deep scarlet, salmon centre, large truss; *Belle Nancienne*, bright salmon, red centre, broad white margin, extra large pips and trusses; and *Le Bruant*, a good deep crimson. Among the singles the most strikingly good were *Bacchus*, rosy purple, fine truss, well-shaped pips; *C. H. Swinstead*, vermilion; *Eurydice*, purple pink white in upper petals, grand truss; *Ferdinand Kauffer*, rich magenta, upper petals tinged with orange scarlet; *Future Fame*, scarlet, very good; *Kate Greenaway*, bright pink, well formed flowers; *Lady Bailey*, rose colour; *Lady Chesterfield*, rich salmon, and good in every respect; *Lucy Mason*, salmon, tinged with orange; *Mary Caswell*, white, flushed pink; *Mr. H. T. Barker*, dark rose; *Mercedes*, salmon and orange; *M. Myriel*, crimson scarlet, white eye, striking; *Norah*, soft blush, large flowers; *Omphale*, pale salmon, very fine; *Paul Neil Fraser*, rich scarlet, white eye; *Plutarch*, bright scarlet, small white eye, fine pips and truss; *Raphael*, scarlet, shade rose and magenta; *Ruby*, rosy scarlet, white eye; and *Zeno*, scarlet, suffused magenta. Of Ivy-leaved sorts the best were *Furstin J. Von Hohenzollern*, dark scarlet, fine pips and truss, double; and *Madame Thibaut*, extra good double pink.

— "UNUSUALLY HEAVY CROPS OF TOMATOES," a gardener says, "are being obtained this year out of doors. By sowing seed of Sutton's Earliest of All in a gentle heat about the middle of April, potting them into 5½-inch pots when required, thereby growing the plants without check, is much better than sowing very early and starving the plants while waiting to place them out. In our case sufficient time was allowed to have the plants strong and thoroughly hardened prior to planting out on a sunny south border the first week in June. The growths—three to each plant—were tied to cross rails erected, the topmost 4 feet high, all side growths were cut away as fast as they showed, the fruits set freely close to the ground and all the way up the stems, the points being taken out of each when the desired height was reached. Water was freely applied to the roots through a thick mulching of manure; the fruit now is swelling to a capital size and shape, and commencing to ripen thoroughly."

— PART 26 of Cassell's "Familiar Trees" is devoted to the CEDAR OF LEBANON, of which a coloured plate is given with historical and other particulars, from which we extract the following:—"The actual date of the first introduction of the Cedar into England is uncertain. A most improbable tradition assigns the planting of the celebrated trees at Enfield and Hendon to Queen Elizabeth, but Evelyn in his "Silva" (1664) speaks of the tree as not grown in England, though he had received cones and seeds of it from Lebanon. Probably the oldest existing Cedar in England is that at Bretby Park, Derbyshire, proved by the gardener's accounts to have been planted in 1676. Its girth is now nearly 16 feet, and its branches, though many have been lost, still spread about 100 feet. The Enfield tree was planted by Dr. Uvedale, head master of the grammar school, apparently between 1665 and 1670, from seed said to have been brought him from Lebanon by a pupil, but possibly given him by Evelyn. William Ashby, a Turkey merchant, is stated to have brought seed from the Levant between 1680 and 1690, from which sprang the Cedar at Quenby Hall, Leicestershire; but the trees standing till recently close to the river, in the garden of the Apothecaries' Company at Chelsea, were certainly planted before 1685, under the direction of Sir Hans Sloane."

#### JUDGING GRAPES AT THE CRYSTAL PALACE, SEPTEMBER 2ND, 1887.

I AM pleased to see that Mr. Barron has thought it necessary in this case to take notice of my public criticism of his awards in the Grape classes at the above Show, because it gives me an opportunity of upsetting some of

his mis-statements. Mr. Barron would have us believe that the sin he has committed consists merely in not having estimated my collection of Grapes as I had done myself, and then goes on to say it was generally admitted that it was quite in order to withhold the first prize but wrong to do more. If I had been the only one who thought I had been badly treated I should never have made my protest, but such was the opinion, not only of Grape growers with whom I conversed, but also of those (strangers to me) who freely expressed their opinions to that effect, all, without a single exception, declaring it to be a most unjust award, and only one considered that the twenty bunches in question should have anything less than a first prize. Then, as to Mr. Barron's assertion that the Grapes were but second-rate, and if placed in competition in the three-bunch classes would not have secured a prize, I should like to ask him if it is usual to see Mrs. Pince in as good condition as to colour and size of bunch at the time I exhibited, and if he noticed any *Lady Downe's* in the Show as well coloured as my own? *Gros Maroc*, *Foster's Seedling*, and *Alnwick Seedling* would also have given a good account of themselves anywhere if staged against the same varieties. Has Mr. Barron ever awarded a first prize in a big collection of Grapes, when the quality was up to the standard of the smaller classes? It is obvious to any practised Grape grower that it is nigh impossible to stage ten varieties of Grapes in as good condition as he could one. The difficulty is to catch them all in their best form at the same time. Take, for instance, the two collections of twenty bunches that have been awarded the first prize at the same Show the two previous years, would they have secured a very prominent position in the three-bunch classes? Collections of Grapes, like collections of fruit, must be judged as collections. If there had been two other collections less meritorious than mine shown in the twenty-bunch class, what would Mr. Barron have done then?

Mr. Barron has misrepresented the value and condition of my collection of twenty bunches when he says that many of them were not fresh. As a matter of fact only four bunches had been exhibited before—namely, the *Madresfield* and *Muscat of Alexandria* which were shown at Salisbury the previous week, and these, as anyone at the Palace could see, were not in anything like the condition Mr. Barron would lead the public to believe, as the bunches were compact and solid, the footstalks being scarcely visible, and were quite fit for the table, otherwise they would not have been shown. Mr. Barron must be aware that several stands of Grapes—including Mr. Taylor's and Mr. Pratt's grand examples—were shown at Bath on the Wednesday and Thursday last year, at the Crystal Palace on the Friday and Saturday, and again at South Kensington on the following Tuesday. As Mr. Barron has been indiscreet enough to mix my employer's name with this subject, I may tell him that he saw the "offending" collection staged on the boards in the vineries here before and after it had been to the Palace. I also "dared" to send the very bunches to table. They were eaten and much appreciated.

It is but natural that exhibitors should sympathise with each other and find fault with the Judges who annually make a large percentage of wrong awards. Not because the "prizes are slipping away from them," but because they have been unjustly treated. There is a wide difference between a "disappointed exhibitor" and a defrauded one. I can assure Mr. Barron that the word patronage, which has so incited him to eloquence, is applied in its proper place, and it has not been used in a bumptious way. Noblemen and gentlemen patronise the Crystal Palace and other companies by allowing their gardeners to compete at the shows which are held for the purpose of drawing the half-crowns and shillings of the public into their coffers.—H. W. WARD.

#### CRAGSIDE.

COMPARATIVELY seldom can we escape from what may be termed the conventionalities of landscape gardening, and it is only when a site possessing exceptional natural advantages has been treated with a taste and judgment equally rare that we obtain a well marked departure from the prevailing garden styles. Even when the situation and surroundings are favourable it requires a certain boldness or independence of spirit, as it were, to take it in hand horticulturally and yet avoid following the common modes of procedure in the production of walks, clumps, plantations, and flower beds. There is the danger on the one hand that insufficient will be done to fully develop the natural character of the place, and on the other that too much will be undertaken, the result being an irksome artificiality. It would be difficult to select a better example of "the happy mean" in this respect than is afforded by the remarkably beautiful garden at Cragside, and Lord Armstrong must have had constantly in view the oft quoted Shakesperian dictum, "This is an art which does mend Nature: change it rather; but the art itself is Nature," when he designed and planted the rugged hillside now so famed amongst northern gardens.

Cragside is within a mile or so of Rothbury station, the terminus of a branch from the North-Eastern line at Morpeth, and is conveniently reached from the south *via* Newcastle-on-Tyne, or from the north by changing at Morpeth. Rothbury is an old Northumbrian village upon the river Coquet, famed for its trout, and a favourite resort for lovers of "the gentle art;" but during the summer time, upon the days when Cragside is generously thrown open to the public, the normally quiet streets are thronged with excursionists from Newcastle and other large towns. On the occasion of the annual flower show in particular numbers of special trains are run from Sunderland, South Shields, and Newcastle, bringing thousands of visitors into the pure and invigorating atmosphere of the Coquetdale district. The journey by rail from any of the towns named offers little in the way of scenery except a passing glimpse of a few deep fertile glens, and the traveller comes quite suddenly in view of the huge, rocky, and precipitous hillside, the silvery Coquet, and its charming valley. *En route* some doubts might arise as to what could have induced a gentleman to select so wild a spot for a residence and garden; but with the Cragside before us, the Heather-clad summit glowing under a brilliant August sun, all such doubts are dissipated. Where the visitor has the time and opportunity, Rothbury

can be reached by road from Alnwick, a distance of about twelve miles, and in fine weather such a drive would be a most enjoyable one.

Passing from the station, across the river, and through the village, the road turns sharply to the right, and ascends slightly until the entrance to the garden is reached, but the main entrances and coach roads are some distance from this point at opposite ends of the garden. The path becomes steeper from the lodge entrance until a long range of vinerias and Peach houses is passed on the left, and a kind of terrace or plateau is reached. Here there are several houses and other matters worthy of note, but they will be referred to presently, as there are other greater attractions to be seen. The path descends slightly from there, winding between steep banks and through plantations of choice Conifers, until the iron bridge is reached, spanning the valley of the Debden Burn, and commanding a superb view of the mansion and the rocky heights of Cragside. When Lord Armstrong acquired this estate some twenty years ago this was little more than a barren waste, but now it is as though a horticultural magician had waved his wand over the scene. The whole place is full of vigorous vegetative life—the banks of the stream are clothed with dense plantations of deciduous and evergreen trees, and the hillside itself is one vast alpine garden, rising to the height of some hundreds of feet above the valley. One might almost fancy that the stone had been quarried here for ages on a gigantic scale, for at a distant view the hillside seems nearly perpendicular; but though it is extremely steep and in some places quite precipitous, it is found on a nearer inspection that some parts are set back as it were, forming natural terraces that have been taken advantage of to form roads and paths by which the summit can be gradually gained.

Just above the bridge on the opposite side of the valley is the mansion (fig. 32), a handsome structure of stone, literally founded on the rock, for a plateau and terrace had to be formed upon which to erect it. The path approaching from the bridge ascends to a grand bank of Rhododendrons, which are flourishing as they are too seldom seen in the south, and must present a magnificent spectacle when in flower, and clambering over the huge masses of levelled rock we emerge upon the terrace commanding another and more extensive prospect. The valley stretches away for miles to the right and left; in the latter direction it opens out and a series of bold hills is seen, of which Simonsides rises above 1400 feet, giving much character to the scene. In the other direction are the extensive lakes and the plantations of Scotch Fir and other trees, with which about 1400 acres are occupied. All around in every crevice between the rocks where any soil will lodge, or in huge beds, are the Gaultherias, which thrive like weeds and produce a fine effect. *G. Shallon* is extensively grown, also *G. procumbens* and *G. acuminata*, the last named fruiting with extraordinary freedom, and at this time of the year is nearly black with its fruits. Another very noticeable feature at this point, too, are the huge beds of dwarf Polygonums 12 feet or more in diameter, and which at a distance form great masses of rosy coloured flowers that have a curious effect on the hillside. The most remarkable of these is *P. Brunonis*, and those who are accustomed to seeing small patches or diminutive lots in gardens can form no conception of its beauty grown as it is at Cragside. It seems to flourish in the peaty soil just below the house, producing its long spikes of dark rosy flowers in profusion. *P. vacinifolium* is also grown, but is rather more tender, though both these have been found in Northern India at elevations of 7 to 13,000 feet, together with the European *P. viviparum* in some districts. The value of such plants in places like this cannot be overestimated, especially as in the case of *P. Brunonis* the foliage turns a rich reddish brown in autumn, and remains quite a feature throughout the winter.

Several other plants grown in large quantities may be noted here, and the most conspicuous are the *Pernettyas*, which are thoroughly at home and bear their varied coloured fruits in astonishing numbers. Those that succeed best and are most distinct in the colours of their fruits are *alba*, *atro-rosea*, *atro-sanguinea*, *carnea*, *carnea uana*, *elegans*, *rosea*, *rosea nana*, and *sanguinea*. Some thousands of these are distributed about, but mostly in masses. *Kalmia rubra* and *rubra nana* are found to succeed in exposed places growing and flowering freely, but *K. glauca* needs a more sheltered position. *Andromeda floribunda* is another favourite, and is evidently as thoroughly satisfied with its quarters as the innumerable other occupants of the garden.

Beyond and behind the house the hill rises to a great height, and there are some delightful walks winding among the rocks, in some places approaching the edge of the extremely steep sides, or passing through tunnelled passages, and at intervals huge projecting masses constitute fine pinnacles for observation, many a charming prospect being obtained across the valley and the village of Rothbury. In all directions hardy Heaths are seen in thousands, carpeting every available space of soil and even spreading on to the rocks. In August and September they are very beautiful, especial care having been taken in planting them with a view to effect. About forty varieties are represented, the more distinct being grown by the acre, extensive masses of light and dark coloured varieties contrasting admirably, giving a beautiful appearance to the hillside from a distance. They are chiefly varieties of *Erica vulgaris*, the best being *Alporti*, *Scarlet*, *tenuis*, and the double flowered. Of *E. cinerea* also numerous varieties are represented and found very useful, *alba*, *atropurpurea*, and *rosea* being the favourites. *Saxifragas* are numerous, and there are scores of alpine and herbaceous plants established here in native luxuriance that would require a special treatise to describe or even enumerate. The same principle has, however, been followed as at Jesmond Dene, planting large masses of those that thrive well, little pieces concealed under enormous labels as they are sometimes seen in

so-called rock gardens not being tolerated. The path proceeds to a point where the hill turns sharply to the left, and then returns to a slightly higher level, where on a broad plateau is a fine lake of alpine purity, and then by some ten minutes' vigorous climbing the hill-top can be reached and resting amongst the native Heather which covers it with a dense carpet for a long distance, the full beauties of the Cragside scenery can be leisurely enjoyed. It is not surprising that the proprietor's liberality in throwing open his garden every Thursday in the summer is taken such full advantage of by the public. The place is as unique as it is beautiful, and well worth a few hundred miles journey to see.

Descending any of the several paths in the direction of the house the choice Conifers planted in sheltered and suitable situations attract attention. There are of course no very large specimens at present, but judging by the progress they are making they will soon attain to considerable dimensions. The tallest Conifers scarcely exceed 40 to 50 feet, but amongst these are some fine plantations of *Abies Douglasi*, and specimens of *Piceas Nordmanniana* and *lasiocarpa* with *Cupressus Lawsoniana* nearly as high. Of *Picea nobilis glauca* there are several handsome examples finely proportioned and over 40 feet in height. *Abies Hookeri* though not so large is finely developed, showing its special characters admirably. *Thujaopsis borealis* and *dolabrata* with many *Thujas* and *Biota elegantissima* are very prosperous. *Cryptomeria elegans* and the golden variety of *Juniperus chinensis* are notable amongst other trees. In the warmer sheltered parts of the garden *Retinosporas*, both grow and colour grandly; *R. plumosa* and *obtusa* with their golden varieties and *R. squarrosa* are represented by some handsome plants 10 to 12 feet high, and in perfect health. In the valley Willows, Poplars, Mountain Ash, and various other deciduous trees are planted freely, while, as already mentioned, the higher ground in the outer portion of the estate is occupied mainly with Scotch Firs, of which Messrs. Fell & Co., Hexham, supplied as many as 300,000 in one season.

The fruit and plant houses occupy the garden first mentioned on the Rothbury side of the valley, and one range there 100 feet long is chiefly devoted to Peaches, Nectarines, Figs, and Mulberries in fire-clay pots, with Tomatoes as an additional crop. The pots are somewhat peculiar, of considerable size, and placed on pivots or wheels, so that they can be readily turned without lifting. The house is a rather dry one, and some difficulty is experienced in keeping red spider at a distance, but the Mulberries produce wonderfully fine fruits treated in this way. Another range in a lower garden is filled with Vines, &c., all well showing the care they receive. Several spaces of ground are enclosed by a kind of framework with glass sides, open at the top, and 6 feet or more high, afford protection to some flower beds and a few choice shrubs that would otherwise be damaged by the winds that occasionally sweep across here with much violence. Against a wall *Lonicera sempervirens*, *Akebia quinata*, *Escallonia macrantha*, *Tropaeolum speciosum*, *Aristolochia Siphon*, and *Clematises* in variety are thriving capitally, while in the beds *Gladioli*, *Verbenas*, *Pelargoniums*, *Fuchsias*, *Lobelias*, &c., afford a wealth of colour, the only attempt at formal bedding in the whole establishment.

It should be added in concluding these brief notes that to Mr. W. Bertram is entrusted the general superintendence of the Cragside estate, Mr. Hudson being responsible for the glass houses and flower garden. The management is all that could be desired, but the design of the original planting originated chiefly with the distinguished owner.—LEWIS CASTLE.

### SHOWING AND JUDGING.

WHILE agreeing with much "Experientia Docet" says upon the above-named subject, I cannot altogether condemn large collections of fruit, &c., simply because in two cases the competition was small; nor do I think he correctly states facts when he talks about these big collections containing "anything that could be scraped together for making up the requisite number of dishes." I was not at the late Crystal Palace Show, and the Journal does not record the number of competitors for the various collections of fruit, but I was present last year at the corresponding Show, and find from my notes that seven collections were staged for the twenty dish prize, and generally speaking these contained the best fruit in the whole Exhibition, while in the class specially set aside for the many—viz., the eight dishes, only three competitors put in an appearance. At the same Show four collections of Grapes were staged for the twenty bunch class. That being so last year, there can be no reason why it should not be so again. With regard to the Newcastle Show, beyond all question the great interest of the Exhibition was centered upon the "Jubilee" class, and here again the best fruit of the Exhibition was staged, and the first prize won by Mr. Hunter, and again in the class for eight dishes his second best lot easily carried off the first prize, clearly showing that "Experientia Docet" is mistaken when he asserts that "the fruit on the whole was far more meritorious than in the 'Jubilee' sensation."

Again, let us look at what is going on at Edinburgh. Here the two leading fruit prizes are twelve dishes of fruit and twelve bunches of Grapes. For years the competition was scanty in the extreme, and many were the complaints of a certain class of exhibitors thereon. The Committee persevered, with the result that this year thirteen collections were staged for the twelve dishes, containing by far the best fruit in the Exhibition. In the class for the eight dishes only six staged, while in the class for twelve bunches of Grapes five lots were set up. Here, as at



Newcastle, these big collections were the centre of interest alike with exhibitors and the public. From the above statement of facts it will be seen that those "sensation collections" are not the failure "Experientia Docet" makes them out to be; on the contrary, as is amply testified in almost every exhibition, large collections bring out the resources of large establishments, and thereby many fruits are seen to

advertised. There is no difficulty in inducing the public to visit really good horticultural shows when these are held in readily accessible places and are favoured by fine weather, but a considerable amount of local energy and enterprise is essential in the directorate.

FRUIT.—The fruit classes always constitute the most important portion of this Show, and on the occasion under notice the exhibits were very good

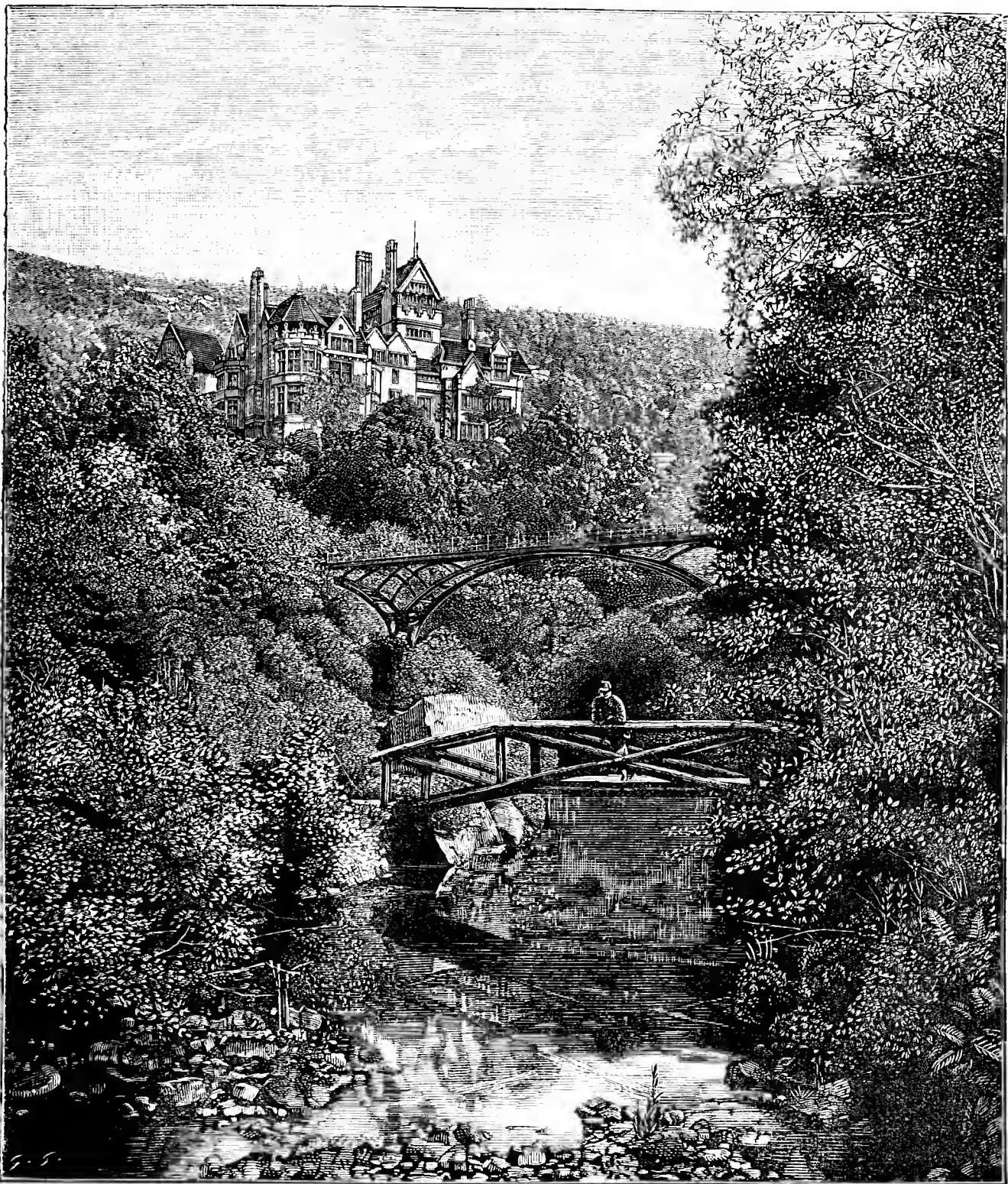

Fig. 32.—CRAGSIDE, ROTHBURY.

advantage which are never met with in six and eight collections—at least such is the opinion of—AN OLD HAND.

## HORTICULTURAL SHOWS.

BRIGHTON.—SEPT. 14TH AND 15TH.

THE Brighton and Sussex Floricultural and Horticultural Society has held many good exhibitions, and that of Wednesday and Thursday last week was no exception to the rule. The competition was keen in most of the important classes, and the display of fruit, flowers, and plants occupied several of the handsome apartments in the Royal Pavilion, a large tent being also required in the garden to contain the specimen plants and groups. Unfortunately the attendance of visitors was not so large as it should have been, and this was probably due to the fact that the Show was not adequately

The leading class, that for a collection of twelve dishes of fruit, brought three competitors, who had capital samples. It was a close struggle between Mr. Waterman, gardener to H. A. Brassey, Esq., Preston Hall, Aylesford, and Mr. C. J. Goldsmith, Kelsey Manor Gardens, Beckenham, for both were showing well, but ultimately Mr. Waterman won first honours, his remarkably well-developed handsome Queen Pine giving much weight to his collection. His other dishes were Gros Maroc and Muscat of Alexandria Grapes well coloured, the former with very fine berries; Hero of Lockinge Melon, Late Admirable and Dymond Peaches, the first somewhat green, the latter of rich colour; Murrey and Humboldt Nectarines, good; Jefferson Plums, Morello Cherries, Beurné d'Amanlis Pears, and Duchess of Oldenburgh Apples. Mr. Goldsmith's collection comprised excellent bunches of Black Prince Grapes, with good berries, and well coloured; indeed this variety is rarely seen so well represented; Muscat of Alexandria and Black Hamburg Grapes, Violette Hâtive Peaches, Pine Apple Nectarines, Washington Plums, Golden Perfection Melon well



netted, and Clapp's Favourite Pears; most of these fruits were distinguished by their ripe condition. Mr. Hodges, gardener to S. C. Gibbons, Esq., Lindfield, was third, his most notable dishes being Duchess of Oldenburgh and Worcester Pearmain Apples and Washington Plums. There were only two Pine Apples shown; Mr. W. F. Smith, gardener to Mrs. Byass, Neville Court, Tunbridge Wells, was first with Smooth Cayenne, a solid, even, well-ripened fruit; and Mr. Moorhouse, gardener to J. W. Temple, Esq., Leyswood, was second with the same variety, also a well-developed fruit, but discoloured on one side.

Grapes were strongly represented in the smaller classes, though there was only one entry of six bunches, for which Mr. T. Chatfield, gardener to T. Holman, Esq., East Hoathly, won first honours. The varieties were Buckland Sweetwater, fine berries and good colour; Muscat of Alexandria, Muscat Hamburg, large bunches; Gros Colman, not fully coloured; Alicante, dense bloom; and Victoria Hamburg, good bunches but reddish. In the open class for three bunches of black Grapes there were fourteen competitors, and some of the exhibits were very close in quality. Mr. W. Colman, The Gardens, Bentham Hall, Southborough, Tunbridge Wells, was first for Alicante, large handsome bunches bearing a dense bloom. Mr. Osman, gardener to C. J. Baker, Esq., Ottershaw Park, Chertsey, was second, also showing Alicante of good size, but not quite so well coloured. Mr. F. Godby, gardener to Dr. W. Moore, Burgess Hill, was third with Black Hamburg, fairly good. In another class for three bunches black Grapes, open only to gentlemen's gardeners and amateurs, there were twelve entries, Mr. F. Godby winning first with compact bunches of Black Hamburg, the berries somewhat small, but of good colour. Equal second prizes were adjudged to Mr. D. Kemp, gardener to C. R. Scrase Dickens, Esq., Coolhurst, Horsham, and Mr. Osman, both having Alicante in fine condition. Mr. T. Robinson, gardener to W. Lawrence, Esq., Hollinour, was third with Madresfield Court. About half these numbers entered in the white Grapes classes. Mr. R. Gray, gardener to Earl Stanhope, Chevening, Sussex, was first in the open class, amongst seven competitors, with Muscat of Alexandria of good size in berry and bunch and finely coloured. Mr. G. Duncan, gardener to C. T. Lucas, Esq., Warnham Court, Horsham, and Mr. Osman followed both with the same variety, the last named having smaller bunches, but much better coloured. In the other class Mr. Spottiswoode, gardener to G. Duddell, Esq., Queen's Road, led with Muscat of Alexandria, followed by Messrs. Kemp and Osman with the same variety.

Peaches, Nectarines, Plums, and Figs made an extensive display, and included some unusually fine fruits. In the class for two dishes of Peaches there were eight entries. Mr. Inglis, Cuckfield, secured the first place with good examples of Alhatross and Princess of Wales. Mr. Moorhouse followed with Dymond and Grosse Mignonne, Mr. W. Smith being third for Walburton Admirable and Golden Eagle. Eighteen single dishes were staged, Mr. W. Smith leading with handsome fruits of Walburton Admirable; Mr. W. Divers, gardener to J. T. Hopwood, Esq., Ketton Hall, Stamford, being a close second for Prince of Wales, of capital size and colour; Mr. G. Stringer was third. In the Nectarine class for two dishes there were nine competitors, Mr. Divers easily winning first honours with remarkably fine samples of Pine Apple and Dryden. Mr. Ridout, gardener to T. B. Haywood, Esq., Woodhatch Lodge, Reigate, was second with Lord Napier and Pine Apple, and Mr. Aslett third for rather Green Victoria and Humboldt. Of the fifteen exhibitors of single dishes Mr. Mndell, Moorpark Gardens, Rickmansworth, was first with Pine Apple excellently ripened; Messrs. Holliday and G. Broomer following with Lord Napier. Plums were represented by seventeen single dishes, Mr. Hodges leading with good fruits of Jefferson; Mr. Burtonshaw was second with Purple Gage, and Mr. Kemp third for Pond's Seedling. Green Gages were also well shown, and the Figs were of unusual size, especially those from Mr. G. Bowles, gardener to Mrs. Finch, Rottingdean, and Mr. Butler, North Lancing, who had huge fruits of Brunswick. Apples were not of special merit, except Mr. Waterman's dishes of Peasgood's Nonesuch and Worcester Pearmain, which were first respectively as kitchen and dessert Apples. Some highly coloured Devonshire Quarrendens from Mr. Morgan, gardener to Major Scott, were also noticeable. Melons were numerous, the prizes being won by Messrs. Stovell, Mundell, Thornton, S. Ford, and W. Smith. Cherries also were shown in good condition, especially Morellos.

PLANTS.—Specimen plants and groups occupied considerable space, and the three classes for the latter included some tasteful arrangements, but the judging was strangely erratic in these classes, and occasioned very general adverse criticism. The singularity of the awards was most marked in the class for a group of Ferns arranged for effect, in which the first prize was awarded to Mr. Offer, gardener to J. Warren, Esq., Handcross Park, Crawley, for a collection of good specimen Ferns, but possessing no special claims as an effective group, and in tastefulness of arrangement it was far surpassed by that contributed by Mr. Jupp, Torfield Gardens, Eastbourne, who was placed second. Mr. Jupp's group had a pretty ground of Adiantums and small Ferns, with a central *Microlepia hirta cristata*, and side plants of *Gymnogrammas*, a few well-grown *Adiantum farleyense* being slightly elevated above the surface. A similar instance of defective judgment was observable in the amateurs' group of miscellaneous plants, Mr. Meachen being placed first with a crowded, heaped-up, arrangement with nothing to recommend it except that the plants were good, and the beauty of most of these was quite lost. Mr. Townshend, gardener to Capt. Thompson, Dyke Road, was second with a really effective and tasteful group, the foundation of Ferns, relieved by *Eucharises*, *Vallotas*, *Crotons*, and *Gloxinias*, with *Acalyphas* and larger *Crotons* at the back. In the nurserymen's class Messrs. Stringer & Co. were first with a bright group in which *Celosias* and *Pelargoniums* were freely employed, but Mr. James's second prize group was much lighter, and would be regarded by many as the more tasteful of the two, Ferns, Orchids, *Dracenas*, &c., being the principal plants used, but it was not finished in quite his usual style. For eight stove and greenhouse plants, Messrs. W. Knight & Co., Birchwood Nursery, Ore, Hastings, were the premier exhibitors, and included amongst their plants a remarkable *Vallota named flammea*, said to be a seedling from *V. purpurea*, the finest variety we have seen of this useful plant. The specimen was 4 feet in diameter, with about thirty trusses of four to seven flowers each, the latter large, with broad rounded petals of rich scarlet hue with a white centre. *Erica cerinthoides* was also fine in the same group; Mr. Meachen, gardener to

Mrs. Armstrong, Woodslee, being second with several good *Heaths*, *Erica Eweriana* particularly so. Mr. Portnell, gardener to Sir H. Lamb, Bart., was the principal exhibitor of four specimen plants, his *Erica cerinthoides coronata* being capital. Mr. Offer, and Mr. H. James, Norwood, were the chief exhibitors in the other classes, showing both flowering and foliage plants. *Pelargoniums* also formed a fine bank of flowers.

Cut flowers, as previously remarked, were abundant, *Roses* uncommonly so for the season. *Dahlias*, hardy flowers, &c., were all numerous. The principal exhibitors were Messrs. Paul & Son, Wollard, G. W. Piper, Perkins & Son, Simmons, Bolton, Slaughter, Rawlings Bros., and Cheal and Sons. Table decorations, houquets, &c., from Messrs. Perkins & Sons, Mr. Butcher, Mrs. Seale, Mr. Chard, and others were good; but in these classes there was also cause for dissatisfaction amongst some of the exhibitors.

Of the non-competing Messrs. Bunyard & Co.'s collection of fruit was the most noteworthy. Mr. George of Putney also had some fine bunches of Duke of Buccleuch Grape, grown with Thomson's Vine manure.

#### GLOUCESTER AND CHELTENHAM ROYAL HORTICULTURAL SOCIETY.—SEPTEMBER 14TH AND 15TH.

THIS Society held its annual autumn Show in the grounds attached to the Winter Gardens, Cheltenham, on the above dates, three large tents being pretty well filled with the various exhibits. These were lighted up at night, and although rain fell heavily at intervals during the first day, the Show was pretty well attended.

PLANTS.—Prizes to the amount of £4, £3, and £2 were offered for six stove and greenhouse flowering plants. There was only one exhibitor—namely, Mr. Cypher, who was deservedly awarded the first prize for grandly flowered *Allamandas Hendersoni* and *nobilis*, *Clerodendron Balfourianum*, *Lapageria alba*, *Bougainvillea glabra*, and a superbly flowered *Vallota purpurea*. £7, £5, and £3 were offered for a collection of thirty plants, in or out of bloom, grouped for effect. Two collections were put up, Mr. James Cypher being easily first, staging grand plants, including highly coloured *Crotons majesticus*, *Johannis*, *Countess*, *Mutahilis*, *Sunset*, *Queen Victoria*, and *Prince of Wales*, large and fresh plants of *Cycas revoluta*, *C. Normanbyana*, *Latania horbonica*, *Kentia Canterburyana*, *Cyathea excelsa*, *Dasy-lirion acrotrichum*, *Phormium Veitchi variegatum*, *Fritchardia pacifica*, and well flowered plants of *Bougainvillea glabra*, &c.; Messrs. Heath & Son were second. Mr. Cypher was also a good first for twelve exotic Ferns, showing, among others, large, fresh plants of *Gymnogramma chrysophylla*, *Adiantum Williamsi*, *Gleichenia Mendeli*, *Alsophila amabilis*, and *Thamnopteris nidus*; Mr. Smith, gardener to Mrs. Pilgrim, being second with even fresh plants. Only two collections were shown. The last named exhibitor had the best eighteen varieties of British Ferns; Mr. C. Lodge the second best; and Mr. E. Smith the third best, all showing creditably grown plants. In the class for six varieties of *Achimenes*, Mr. Lewis, gardener to Mrs. Lingwood, was the only exhibitor, and he secured the first prize for a highly meritorious half dozen large, fresh, and profusely flowered specimens. *Pelargoniums* (*Zonals*) were shown in good style; the first prize nine, in pots not exceeding 10 inches in diameter, and shown by Mr. Lewis, were neatly trained and grandly flowered, both foliage and flowers being very fresh. Mr. H. Sparkes, gardener to H. Chapman, Esq., was second; and Mr. A. Mansfield, gardener to Mrs. Gillman, was third, both showing well. *Enchias* were a pretty good class. Mr. H. Sparkes had the best eight plants in as many varieties, showing pyramidally trained plants about 5 feet high, fresh, and well flowered; Mr. Clift, gardener to Mrs. Graves, was second. There was only one exhibitor of four varieties—namely, Mr. G. Mayo, gardener to P. H. Osborne, Esq., and he obtained a first prize. Mr. Cypher was the only exhibitor in the class for an ornamental basket of plants showing the greatest taste in arrangement on a stand. This, like all Mr. Cypher's exhibits, was a very praiseworthy arrangement, the plants being choice, well chosen for the purpose, and, almost needless to say, set up with good taste. It was greatly admired, not only on account of the choiceness and suitability of the plants used, but also by reason of the complete absence of stiffness in the arrangement.

CUT FLOWERS.—Messrs. Heath & Son were first for twenty-four *Dahlias*, distinct varieties, showing uniform, fresh, substantial blooms of the most approved varieties; Mr. T. Hohbs, Bristol, was a good second. The same exhibitors were accorded a like position for a dozen *Roses* in as many varieties, both showing good blooms; and in the class for twelve fancy *Dahlias* the exhibitors in the two preceding classes were again placed in the same order of merit. *Asters* made quite a good display, all the winning stands coming from a distance. For twenty-four blooms of German *Asters*, in twelve varieties, Mr. G. S. Walter, Calne, was first; Mr. W. J. Jones, Bath, was second, the third prize going to the first prizewinner. For a like number of blooms of French *Asters* Mr. T. Evry (Bathaston) was a good first, Mr. W. J. Jones being second, and Mr. S. Haines third. For three dressed vases for the dinner table Mr. A. Mansfield was first, and Mr. H. Sparkes was second, both arrangements displaying good taste.

FRUIT.—Fifteen classes were provided for fruit in the schedule, but the Committee, at the instance of, and mainly through the exertions of its energetic and courteous Secretary (Mr. W. H. Bridgewater), a departure from previous year's inducements to distant and other fruit growers to stage collections of nine kinds of fruit (*Pine* excluded) was made in the offering of special prizes—£10, £5, and £2; and the Committee and Secretary are to be congratulated upon the excellent competition which these prizes, as might be expected, brought out, seven good all-round collections having been staged. Mr. J. H. Goodacre, gardener to the Earl of Harrington, Elvaston Castle, Derby, was first, showing good, well-finished bunches of *Madresfield Court* and *Muscat of Alexandria Grapes*, the centre bunch of the latter having been rubbed in transit; the bunches were medium-sized, clean, and superbly coloured; good *Brown Turkey Figs*, *Sea Eagle Peach*, good *Violette Hâtive Nectarines*, large *Victory of Bath Melon*, *Washington Plums* (large and well coloured), *Moorpark Apricots*, and *Morello Cherries*. Mr. Rose, gardener to Lord Wantage, Lookinge House, Wantage, was a good second, his best dishes being *Muscat of Alexandria* (heavy-shouldered bunches, having large and well-coloured berries), *Brown Turkey Figs*, *Jefferson's Plums*, *Lockinge Melon*, and *Williams' Bon Chrétien Pear*. Mr. Nash, gardener to the Duke of Beaufort, Badminton House, Chippenham, as a very close third; this collection had a grand dish of *Brunswick*

Figs, equally good Humboldt Nectarines, and a fine fruit of Golden Perfection Melon, 7½ lbs. in weight. There was very little between these three collections in point of merit. Mr. D. Child, gardener to the Earl of Coventry, Crome Court, Kempsey, Worcestershire, was very highly commended. His collection included medium-sized bunches of Gros Colman, having grandly coloured berries, carrying a fine bloom. There were only two collections of six kinds of fruit staged, the first prize going to Mr. James, gardener to the Rev. G. Coventry, who showed good Brown Turkey Figs, Black Hamburg and Muscat Grapes, the latter rather deficient in colour, Peaches, &c. Second, Mr. Cook; third, Mr. Hall. The latter collection contained a small Pine Apple. Mr. R. W. Wanson, gardener to Mrs. Thomson, had the best four dishes of fruit, showing Black Hamburg and Muscat of Alexandria Grapes, Pine Apple Nectarines, and Noblesse Peach—four creditable dishes. Second, Mr. Clift; third, Mr. Hall. Grapes were not shown in large numbers, but some of the first-prize bunches were excellent. For two bunches of black Grapes, distinct, three bunches of each, first, Mr. W. Child, with neat well-coloured bunches of Gros Colman and Black Hamburg; second, Mr. James, with Lady Downe's and Black Alicante in good condition; third, Mr. Harden, gardener to Sir George Cooper. For a like number of bunches of whites Mr. James was first with Muscat of Alexandria and Foster's Seedling, the latter rather green. Second, Mr. Clift. Mr. Nash was easily first for one dish of black Grapes, showing three handsome and well-finished bunches of Black Alicante in real Badminton style. Second, Mr. Green, gardener to Major Roberts; third, Mr. A. Cook. Peaches were not a good class. Mr. Rose was first with Ward's Late (?), Mr. Child was second, and Mr. W. Allen, gardener to Mrs. Kelley, was third. Six were staged. Out of five collections of Nectarines, Mr. W. Allen was first with Hardwick Seedling, Mr. H. Moorman second with Lord Napier, and Mr. W. Child third with Stanwick, all showing good fruit. Melons were a good class. Nine pairs were staged. Mr. James was first with a variety named Woolstone Scarlet; Mr. O. Arkell, gardener to Mr. A. J. Shinner, was second; and Major-General Little, Stroud, was third. Apples, Pears, Plums, and Cherries were well shown by Mr. James (who was first in three of the classes), Mr. Moorman, Mr. W. Child, Mr. Turk, and Mr. R. Wanson. Messrs. George Bunyard & Co., of Maidstone, staged (not for competition) a neat collection of twenty-five dishes of Apples, which attracted a good deal of attention from gardeners and others interested in Apple culture. The most highly coloured specimens were Duchess of Oldenburgh, Duchess of Gloucester, and Worcester Pearmain.

**VEGETABLES.**—These were shown largely and of excellent quality, nineteen classes being provided for them, all the prizes being well contested. There were collections of nine kinds and six kinds respectively provided in the Society's schedule, the exhibitors giving a most liberal interpretation to the word "dish," inasmuch as piles the size of a bushel basket of the respective kinds were put up in the collection of nine kinds, as will be seen by the following—First Mr. O. Arkell, with a most imposing collection of excellent all-round kitchen garden produce, consisting of Potatoes, Sutton's Exhibition Sprouts, large and firm, Capsicums the size of small Vegetable Marrows (about 200), twelve handsome fresh and evenly matched Cucumbers, nineteen perfect specimens of Cauliflower, fifty handsome Tomatoes of uniform size, 100 clean Turnips, eighteen large and well-blanching heads of Celery, about half bushel of excellent Peas, and a like quantity of Potatoes all being admirably staged; second Mr. A. Cook; third Mr. J. Turk. There were only two collections of six kinds put up—namely, by Mr. James and Mr. P. H. Osborn, who took the prizes in that order with excellent produce. Dishes of twelve Tomatoes made a capital show. Mr. A. Cook was first with large highly coloured uniform fruits of Stamfordian; Mr. O. Arkell was a good second; and Messrs. Heath & Son a good third. Mr. O. Arkell had the best six heads of Broccolis, showing large compact heads of what appeared to be Veitch's Autumn Giant in fine condition; Mr. Turk and Mr. Cook were second and third in that order. Turnips were shown in large quantities and of excellent quality:—First (Messrs. Harrison & Son's Leicester prize) Mr. Arkell, who showed a good peck of clean medium sized roots, which, like the majority of the exhibits in this section of the Show were not named, the second and third going to Mr. Cook and Mr. Turk in that order. Cucumbers were shown in fine condition, Mr. Arkell had the best three, Mr. Cook and Mr. James being second and third respectively, all showing model fruits. The same exhibitors occupied like positions in the class for six sticks of Celery, showing large well-blanching heads. French Beans, Beet-root, Carrots, Peas, Onions, and Parsnips were also shown well by the last named exhibitors and others. Potatoes, three collections of Potatoes of twelve varieties, eight tubers of each, were put up in fine condition as regards size and quality. First, Mr. Cook; second, Mr. Evry; third, Mr. Arkell. The first prize collection included Mr. Breese, Magnum Bonum, Schoolmaster, Fidler's Reading Giant, Early Rose, Sutton's Seedling, Prime Minister, Fidler's Prolific, White Elephant, Beauty of Hebron, Vicar of Laleham, and Ashleaf. In the classes for one peck round and one peck of kidneys, in the former Mr. Pilgrim, Mr. James, and Mr. Turner were the prizewinners in that order, and in the latter class Mr. A. Cook, Mr. Arkell, and Mr. James were the prizewinners. The basket of salad class brought three competitors, two of which are at the bottom and one at the top in the centre of the open space between the side stages of the vegetable tent, and on which were staged all the other produce, were works of art. The baskets—large oval ones—were supported by suitable stands, and were spanned by handles in the shape of a crown and other devices at some 2 feet from the rims of the baskets, all being covered with Parsley, &c., in and around which every variety of the best quality of salading were most artistically arranged, the bright Radishes, Tomatoes, &c., dotted here and there on the groundwork of beautifully blanched Endive being very effective, an effect which was heightened when the tents were lighted up at night. Mr. J. J. Smith was first, and Mr. A. Cook an uncomfortably close second. Mr. Evry was third for a formal arrangement of excellent quality.

#### MANCHESTER SHOW.—SEPTEMBER 16TH AND 17TH.

A CORRESPONDENT sends the following list of awards at the recent Manchester Show, and remarks that the exhibits were highly satisfactory, a capital display being provided in the avenue and under the dome of the great Exhibition. Mr. A. Herne of Fallowfield had a fine collection of Orchids and other plants tastefully arranged.

**FRUITS (OPEN CLASSES).**—Ten dishes of fruit: 1, Earl of Harrington; 2, W. Pratt, Longleat, Warminster. Six dishes of fruit: 1, Earl of Harrington; 2, W. Pratt. Collection of Grapes, five kinds, two bunches each: 1, J. Chaffin, Bath; 2, Earl of Harrington. Two bunches black Grapes: 1, Sir U. Kay-Shuttleworth, M.P.; 2, J. F. Campbell, Uttoxeter. Two bunches Alicante Grapes: 1, J. Chaffin; 2, J. F. Campbell. Two bunches Muscat of Alexandria Grapes: 1, W. Pratt; 2, J. Chaffin. Two bunches of any other white Grape: 1, Earl of Shrewsbury; 2, Sir T. Edwardes-Moss. Four dishes Peaches: 1, J. Edmonds, Bestwood, Arnold, Notts; 2, Sir H. H. Vivian, M.P. Four dishes Nectarines: Earl of Harrington. One dish of Peaches: 1, Marquis of Cholmondeley; 2, Earl of Shrewsbury. One dish Nectarines: 1, A. G. Grant, Chelford; 2, Earl of Shrewsbury. Three Pine Apples: 1, J. Edmonds; 2, Sir H. H. Vivian. One Pine Apple: 1, Sir H. H. Vivian; 2, J. F. Campbell. One dish Apricots: 1, Earl of Shrewsbury; 2, Colonel H. C. Legh, Knutsford. One Melon (green flesh): 1, Earl of Shrewsbury; 2, W. Iggulden, Frome. One Melon (scarlet flesh): 1, P. Thellusson, Doncaster; 2, Earl of Harrington. Four dishes Plums: 1, Duke of Sutherland; 2, Earl of Harrington. Two dishes Figs: 1, Sir H. H. Vivian; 2, W. Pratt. Six dishes of Tomatoes: 1, W. Iggulden; 2, Mrs. C. A. Hoare, Beckenham. Collection of Apples, twelve kinds: 1, J. Edmonds; 2, Earl of Harrington. Collection of Pears, eight kinds: 1, Mrs. C. A. Hoare; 2, P. Thellusson. Four dishes of Apples (kitchen): 1, W. Pratt; 2, Earl of Ellesmere. Four dishes of Pears: 1, P. Thellusson; 2, H. J. Clayton, Tadcaster. One dish of Apples: 1, J. Ridsdale, Lincoln; 2, S. Barlow, Manchester. One dish of Pears: 1, H. J. Clayton; 2, J. Ridsdale.

**CUT FLOWERS.**—Forty-eight Dahlias: 1, W. Boston, Bedale; 2, Messrs. Fish-r, Son & Sibray, Sheffield. Twenty-four Dahlias: 1, W. Boston; 2, Heath & Son, Cheltenham. Twelve Dahlias, Fancy varieties: 1, W. Boston; 2, Mr. C. Turner, Slough. Twenty-four single Dahlias: 1, Harkness and Sons, Bedale; 2, R. B. Laird & Sons, Edinburgh. Collection of Gladioli spikes, not less than thirty varieties: 1, A. E. Campbell, Gourrock; 2, J. Burrell & Co., Cambridge. Twelve spikes of Gladioli: 1, M. Smith, Prestwick, N.B.; 2, Harkness & Sons. Six spikes of Gladioli: 1, M. Smith; 2, Harkness & Sons. Eighteen Hollyhock blooms: 1, W. Boston; 2, R. B. Laird & Sons. Eighteen Asters: 1, S. Barlow; 2, F. Law, Rochdale. Eighteen spikes Phloxes: 1, James Dickson & Sons, Chester; 2, Paul and Son, Cheshunt. Collection of Roses: 1, J. Cocker & Sons, Aberdeen; 2, Paul & Son. Twelve Roses: 1, James Cocker & Sons; 2, Harkness and Sons. Collection of hardy flowers: 1, James Dickson & Sons; 2, Paul and Son. Eighteen spikes of Stocks: 1, Mrs. E. Mellor, Chorlton-cum-Hardy. Collection of cut stove and greenhouse flowers: 1, A. Heine, Fallowfield; 2, S. Baerlein, Didshury. Collection of early-flowering Chrysanthemums: 1, Harkness & Sons; 2, S. Barlow. Collection of French and African Marigolds: First prize withheld; 2, F. Law.

#### NOTES AT READING.

THE Portland Nurseries have been previously referred to in the Journal. They comprise a fair extent of ground, which is chiefly devoted to special trials of flowers, fruit, and vegetables, and ranges of glass houses specially constructed for the cultivation of choice florists' flowers for seed. Messrs. Sutton have devoted years to the building-up of first-rate strains of Primulas, Begonias, Gloxinias, Cinerarias, Calceolarias, &c. How they have succeeded in the former case Londoners have an opportunity of seeing at the Royal Aquarium, Westminster, in spring, and the Reading firm may perhaps show what it can do with some of the other flowers named in due time.

Begonias are magnificent. Several houses of tuberous-rooted varieties are grown solely for the supply of choice seed for retailing amongst their customers. One attractive houseful had done duty in June at the Jubilee decoration, and the plants were temporarily crippled in consequence, but they have now recovered, and are flowering profusely. The richness and variety of colour that these plants display is well known. In other structures large numbers of plants are grown for supplying seed of the "Reading Beauty" strain, which comprises some seven or eight distinct colours. The crimson, scarlet, and salmon flowers are very fine. An attractive variety offered under the name of Meteor was in good condition. This bears a profusion of flowers of a bronzy apricot hue, and is pleasing both in bloom and foliage. It is a cross between semperflorens and Pearcei. The old B. Froebeli is admired too. This is very bright and free, and its value is enhanced by the long duration of its flowering season. Plants at Reading are all gay now, and it will remain so until November or December, long after the others have entered upon their winter rest. The Reading Begonias are dwarf, bushy, and compact, well furnished with bloom throughout. A charming little Begonia grown as an edging is worthy of note. It was little more than 6 inches high, and bore a profusion of salmon-rose flowers. The value of Begonias for the purpose indicated is perhaps hardly recognised as widely as it ought to be: dwarf, floriferous, bright in colour, and long-lasting, they are just the plants for forming edgings to borders.

It is not Cyclamen time, but the Reading plants well deserve a passing reference. Every plant is in splendid condition, the leaf stems stout and clean, the leaves nearly firm in texture, and of the clear hues that denote perfect health. Such plants as these are attractive by their foliage alone. That they receive exactly the treatment best suited to them may be seen at a glance. These plants dislike drought and continual shade, but love moisture, hence a pleasant, somewhat humid atmosphere is provided. The plants are in 6 and 8-inch pots, and those in the latter size are quite a foot in diameter.

Some late Gloxinias were in bloom at the time of my visit, while seed was being gathered of earlier plants. Those in flower comprised erect and drooping varieties, and the strain was an excellent one, the flowers being large, the colours rich and varied, the foliage ample and



healthy. These were an example—and a good one—of the six-months-system of culture.

A Tomato trial of some importance is being conducted by Messrs. Sutton; between sixty and eighty varieties are being tested, and they comprise fruits of all sizes and shapes. There are Tomatoes in the shape of Currants, Grapes, Cherries, Plums, Apples and Pears. The plants occupy an open quarter, each having a stout stake some 3 feet high for its support, and each occupying only about a foot of space each way, lateral growth not being permitted. Many varieties were of great excellence, but two attract special notice. The first was a small-fruited variety of extraordinary productiveness, the fruit hung on the plants literally like ropes of Onions, twenty or more being counted in several clusters on the same plant. This variety will no doubt be named during the coming season. The second sort referred to was Reading Perfection, a fine kitchen and exhibition Tomato that has won many prizes this year. The fruits are handsome and of great size, bright scarlet-crimson in hue. This bears very freely, and should soon prove very popular. There are many novelties in this large collection of great merit, and they will perhaps be heard of by-and-by.

Cockscombs in  $\frac{1}{2}$ -inch pots were worthy of note. The plants were healthy little specimens, the combs curling well over the rims of the pots. Trials of Melons and Cucumbers were in progress. The latter were growing in a sharply sloping span-roof structure, plants of each variety being grown at the north and south sides, so that one secured no advantage over another from position. Outside many varieties of Phlox Drummondii grandiflora were being tried. These splendid half-hardy annuals have endured the drought wonderfully well, and have flowered with great freedom over a long period. The plants grow about a foot high, and the flowers embrace every shade of colour. There was a fine lot of Petunias too, and a broad border of Portulacas on a sunny exposure. These must have looked magnificent at their best, unfortunately they were nearly over. A final word must be devoted to the Hollyhocks. Some hundreds of plants 6 to 7 feet high were grown in rows neatly staked, and they were blooming grandly, no trace of disease having appeared.—VISITOR.

## INDIAN EXPERIENCES.

(Continued from page 214.)

### THE NEILGHERY HILLS.

It was at the beginning of 1867 that I left the Wynaad district for the first time, having obtained a situation on the Neilgherry Hills to superintend the opening of a large Chinchona plantation at a place called Deva Shola, situated about ten miles to the south of Ootacamund, the chief town of the Hills. Before, however, giving an account of my experiences as a Chinchona planter, I may be allowed to say a few words on the general aspect, climate, and capabilities of the Neilgherry range, which is without doubt one of the most interesting spots to be found in the whole of our vast Indian possessions, more especially on account of its climate, which is so admirably suited to the European constitution, and producing in a high degree of excellence a vast number of trees, plants, and vegetables similar to those cultivated in Europe.

The Neilgherry Hills (or more correctly, Nilgiris, from the Tamil "nil" blue, and "giri," a mountain) are situated between  $11^{\circ}$  and  $12^{\circ}$  north latitude, and  $76^{\circ}$  and  $77^{\circ}$  east longitude, and range in altitude from 6000 to about 9000 feet above the sea level. They are some 250 miles from the Coromandel coast on the eastern side, and forty miles from the Malabar coast on the western. The area may be roughly taken at 1000 square miles. The Nilgiris were first visited by Europeans in the year 1820. They are believed to have formed part of the territory of the Pandyan kings, whose dominions included Travancore and the Western Ghats. The average rainfall is 50 inches in the north and east, and increasing to nearly 100 inches towards the south and north-west. The Nilgiri Plateau is subject to the influences of both monsoons; the south-west monsoon in June, July, and August, and the north-east monsoon in October and November. The geological formation is of the primitive igneous order, the mass of the mountains being granitic. There is little or no lime in the composition of the soil, which nevertheless is rich and productive. The natural aspect is undulating, with isolated patches of low, but very beautiful forest, called Sholas, on the slopes, from the majority of which flow perennial streams of the purest water of more or less volume. There are many swampy hollows, the beds of which have a considerable depth of black mould, and there are bogs in several parts of the Hills, the peat from which is extensively used as fuel. The undulating land, or as Sir E. Grant Duff admirably puts it, the "rolling downs," separating the beautiful schola patches, are covered mostly with short grass, with here and there clumps of shrubs, such as Hypericum, Indigofera, &c. Splendid groups of the Rhododendron arboreum are frequently met with, and are very striking when in full flower about the month of December.

The climate of the Nilgiris is invigorating, and has been declared by competent authorities to be one of the most equable in the world. The following is a correct statement of temperature, &c.

Mean annual temperature .. .. .	59°
Maximum .. .. .	71°
Minimum .. .. .	38°
Max. power sun's rays .. .. .	21° 73'
Average range .. .. .	17°

At Ootacamund, the loftiest and most important station on the Hills, according to a series of observations extending over seven years,

the mean maximum temperature ranges from  $60.06^{\circ}$  in December to  $68.76^{\circ}$  in May. The hottest months of the year are April and May; the coldest December and January. The hottest hours of the day in summer and winter do not vary more than  $9^{\circ}$ , and the extreme variation of temperature throughout the year is only  $21.15^{\circ}$ . The mean annual temperature of the four principal stations on the Nilgiris as compared with that of London and the three Presidency capitals of India stands something as follows:—London,  $50^{\circ}$ ; Ootacamund,  $57^{\circ}$ ; Kotergherry,  $62^{\circ}$ ; Wellington,  $62^{\circ}$ ; Coonoor,  $64^{\circ}$ ; Caleatta,  $78^{\circ}$ ; Bombay,  $81^{\circ}$ ; and Madras,  $85.2^{\circ}$ . The second, third, fourth, and fifth named places are the most important stations on the Nilgiris, and have an elevation above sea level of 7227, 6427, 5860, and 5927 feet respectively.

Ootacamund is the coldest and Coonoor the warmest station on the Hills, Kotergherry is a medium between the two. The climate of Wellington, where the extensive convalescent barracks for the army of the Presidency are situated, is the same as that of Coonoor. The latter station being near the edge of the Ghaut on the eastern side is subjected to thick fogs from the sudden condensation of the moisture contained in the heated atmosphere rising from below the tableland.

This may perhaps convey to the reader some general idea of the adaptability of the Nilgiris to the European constitution. If further proof were wanted it could be found in the healthy and robust appearance of the permanent English residents on the Hills, as well as in the rosy cheeks and buoyant spirits of the European children.

The products of the Hills include Tea, Coffee, Chinchona, Peaches, Oranges, Loquats, Pears, Apples, Plums, Potatoes of excellent quality, and most of the other English vegetables, which are all produced both by European and native of exceptionally good quality, and all the year round. Wheat is also grown as well as Barley, Mustard, Poppy seeds, Garlic, two kinds of Millet, called in the native language Koralie and Samay (Panicum italicum and P. miacum). The last two are extensively grown by the native population, but their cultivation is of a very wasteful description. A piece of land is chosen, ploughed, and harrowed, and the seed sown, land is chosen that has not been under cultivation for some years, no manure is applied, and when the crop is gathered the land is left to itself for perhaps three or four years before it is ploughed again.

No such thing as flat land exists on the Nilgiris excepting the swamps. Consequently when the land for the cultivation of grain is ploughed and loosened on the hillsides large quantities of soil are swept down to the ravines below by the heavy rains. This denudation goes on to such an extent that I have seen whole hillsides rutted and furrowed to such an extent before the roots of the grain could make sufficient progress to hold it, that it seemed wonderful how a crop could be obtained at all. Of course it never enters into the native mind to construct catch drains or anything of that kind; and, worse than all, he has no one to instruct him. This sort of thing has been, no doubt, going on for ages, the strata of soil becoming thinner and thinner and the crops shorter in ear and in straw year by year.

Another plant called Keeray by the natives (Amaranthus campestris) is grown by the hill tribes, the seeds of which when ground into flower is much relished. A large field of this plant when in full flower has a very striking and beautiful appearance. There are two varieties, one having leaves, stems, and flowers of a bright scarlet colour, and the other of a yellow or buff colour, and when mixed have a very beautiful appearance. The leaves are also eaten as a Spinach. Numbers of English flowers flourish with little or no cultivation, including the Dahlia, Fuchsia, Heliotrope, Pelargonium, Verbena, Petunia, and numerous others. Fuchsias and Heliotrope are greatly used in the formation of hedges, and are to be seen in flower all the year round, the latter particularly making a very beautiful hedge if kept well trimmed, the scent from the flowers being very powerful. It is no uncommon thing to see at Coonoor and other places of the same elevation Pears, Apples, Plums, Oranges, Dahlias, Loquats, Geraniums, Coffee, many varieties of Hibiscus, Tea, Petunias, Allamandas, Asters, Poinsettias, Calceolarias, Begonias, Rhododendrons, Lilies, Roses, and scores of others growing side by side and flourishing in one garden. Passiflora edulis and several species of Taxonia also grow and fruit freely at these elevations. At lower elevations on the eastern slopes tropical fruits and spices are grown, such as the Nutmeg, Clove, Cinnamon, Mango, Shaddock, Pomegranate, Lychee, and many others.

Deva Shola, or the God's Wood, the place I was appointed to, is situated, as I have already said, about ten miles to the south of Ootacamund with an elevation a little over 6000 feet above sea level. The estate, consists of 1000 acres, 500 of which is forest land and the remainder grass. This land was obtained from Government upon certain conditions, one of which was that the proprietors should supply to the Government so many thousand cartloads of firewood (always a scarce commodity on the Nilgiris) within a given period, cut and stacked from the forest then standing. The proprietors, after having obtained the title deeds of the land from Government, thinking the above condition irksome, and that it might probably hamper them in the rapid planting of the forest area of the estate with Chinchona—for the one object with private planters in those early days of Chinchona planting on the Nilgiris was to be first in the market with bark at whatever cost—bethought themselves of a plan which was ultimately adopted, but which proved, as the sequel will show, vastly more disastrous to the proprietors than to the Government. The plan carried out consisted of first felling the whole of the forest area of 500 acres, which was one continuous block, cutting and stacking the stipulated numbers of cartloads of firewood while it was green, and then politely requesting the



Government officials to have it removed at their earliest convenience. The Government were at that time engaged on the erection of the large pile of buildings called the Lawrence Asylum at a great cost within a few miles of the estate, and requiring a large amount of firewood for brick-burning purposes, &c., made the above arrangement, thinking the supply would be spread over a number of years, and that they could cart it away according to their requirements. They were therefore greatly inconvenienced by this act on the part of the proprietors, which proved, after all, to be but a very short-sighted stroke of policy.

The forest had been all cut for some time before I took charge, and the aftergrowth had already begun to make its appearance above the felled timber to a considerable extent, which I viewed with no little alarm, well knowing the difficulties that were in store for me. The primary objects in all planting operations in India or where the growth of vegetation is so rapid, is first to prepare a nursery of young plants; secondly, immediately the felled jungle has become dry enough to burn at once, then pit and plant the whole area thus cleared during the first season if possible; and all planters of any experience will invariably put forth their most strenuous efforts to gain this end, for the reasons that the ground can afterwards be kept clear of weeds at a minimum of expenditure, whereas should any land be left unplanted the undergrowth is sure to attain formidable dimensions before another planting season comes round, weeds also springing up and seeding, rendering subsequent cultivation a very serious matter as regards expenditure both of time and money. This will, in some measure, explain the situation in which I was placed in taking over charge of the property. Instead of the ordinary routine of planting operations having been hitherto adopted the order of things had been exactly reversed, and I found myself face to face with 500 acres of felled forest which had been cut some eighteen months before, with masses of green aftergrowth appearing all over the surface, including thousands of plants of the formidable *Solanum ferox*, and many other species of tall growing and thorny plants of the same order. With only one small nursery in course of formation, and with a glass house with a limited number of pots of seedling *Chinchonas*, and no dwelling house save a rough building intended for a stable, I cannot say that I relished the appearance of things at all. However, I was now in a good climate, a charming and interesting locality, with abundance of good labour and plenty of money at command, so I went with a will to the work of simultaneously constructing a house, rearing some 600,000 seedling *Chinchona* plants under glass, and forming large outdoor nurseries.

At the time of which I write there were no private *Chinchona* plantations on the Nilgiris, or if any did exist they were yet in a state of embryo. The Government, under the superintendentship of the late Mr. W. G. McIvor, were pressing forward the cultivation and extension of their plantations on different parts of the hills, and, as Mr. McIvor was considered at that time to be the only authority on *Chinchona* cultivation, his directions were very generally followed by private individuals. Very few of the trees on the Government plantations had seeded till within a year of the time I took charge of Deva Shola; but at that time seeds of the *Succirubra* species could be had in abundance, and the plan adopted for raising them was as follows:—The seeds were sown in shallow pans containing sand and brick dust only, and were left uncovered and kept continually moist. After germinating, and when the plants were large enough to handle, they were pricked off into other pans filled with the same material. When the plants had attained a height of about 2 inches they were removed to the nurseries. As time went on it was found that richer soil in the pans had the effect of bringing the seedlings on quicker, till eventually the system of raising seedlings under glass was abandoned altogether, Dame Nature having pointed out in the most unmistakable manner the easiest mode of propagation—viz., sowing in the nurseries thickly in beds without any covering of soil, but simply shading from the hot sun. The hint was taken in the first place by someone finding on one of the Government plantation innumerable seedlings springing up under the shade of the large seedling trees after the heavy rains had ceased. After this tens of thousands of young plants were annually collected from under the trees and transferred to nurseries, and large quantities of plants were raised from seed in the nurseries in the manner described.—PLANTER.



#### ORCHIDS AT TULSE HILL.

MR. W. HALL, Upper Tulse Hill, is well known amongst suburban orchidists, for in his collection, though only of moderate size and contained in two span-roof house, includes some rare and valuable species and varieties. A strong plant of the handsome *Lælia Turneri* has been flowering recently, and showed the character of this fine Orchid admirably. It is one of the *L. elegans* type, but is readily distinguished by its much larger flowers and more brilliant colours. The flowers are about 6 inches

in diameter, the sepals and petals rosy purple with deeper veins, the lip an intense magenta at the base, a tint scarcely equalled amongst other Orchids. Mr. Hall's collection also comprises some healthy plants of *Oncidium macranthum*, some very choice hybrid *Cypripediums*, and a number of other plants of considerable interest. It is surprising how well they all grow under similar treatment; their condition indicates, however, that they receive careful attention.—B.

#### ODONTOGLOSSUM SCHROEDERIANUM.

At the last meeting of the Royal Horticultural Society, September 13th, Baron Schroder sent a plant of this scarce *Odontoglossum* from his collection at The Dell, Egham, and a first-class certificate was at once awarded for it. Messrs. J. Veitch & Son give a description of it in their manual of Orchidaceous plants, and quote Professor Reichenbach's description as follows:—"A unique *Odontoglossum*, quite unlike anything that has appeared before in Europe. The sepals and petals are oblong, acute, wavy, white with mauve purple blotches; the lip is pandurate, white with two mauve purple blotches on the fore part of the disc, and the calli are yellow with some red spots. A much-developed callus in front of the column shows on each side a flute of radiating spines, as in *O. tripudians* and *O. Pescatorei*. It may be a cross between these." The plant is said to have first flowered in Baron Schroder's garden about 1882, but we believe that Messrs. Sander & Co. claim to be the introducers. In any case it is very scarce, and it is distinct enough to merit the honour it obtained at South Kensington.

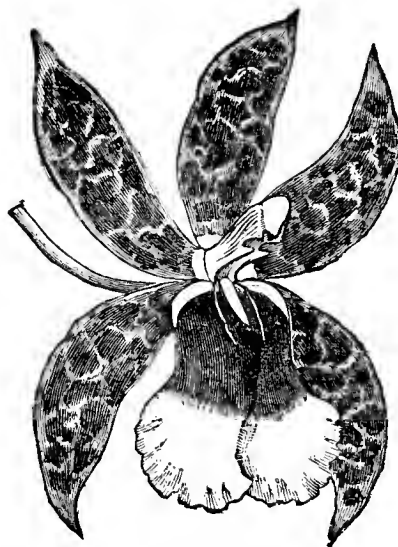

Fig. 33.—*Odontoglossum Schroederianum*.

The flowers are about 2½ inches in diameter in a raceme of three on the plant shown. The sepals and petals scarcely correspond with the description given by Reichenbach, as they are heavily blotched and mottled with brown, and tipped with green; the lip, too, is bright crimson at the base and white at the tip. The growth and pseudo-bulbs resemble *O. hastilabium*.

#### HOLIDAY IN THE SOUTH.

(Continued from page 203.)

##### FAREHAM.

WE leave the Island via Ryde, and cross the water by steamboat to Stokes Bay, thence on by rail to Fareham, where we stop to make a call on Messrs. W. & G. Drover, florists of that town. A walk of about ten minutes brought us to their place of business. *Chrysanthemums* was the subject uppermost in our mind at the time, for during the past three or four seasons the firm have gained a reputation among *Chrysanthemum* growers and exhibitors, and have taken many prizes in the metropolitan and other *Chrysanthemum* exhibitions in the south of England; in fact it might safely be said that no firm in the trade, since the time of Mr. Adam Forsyth, have been so successful with cut blooms, more especially incurved, as have the Messrs. Drover. The prize cards with which the roof and walls of their office are covered testify to their success. These have been received chiefly for *Chrysanthemums* and floral decorations, for *Chrysanthemums* are not the only plants that receive attention at their hands, as all the leading flowers, for which there is the greatest demand for cut flower decoration, are grown in quantities here. There are 20,000 feet of glass devoted to the various plants, three long houses are occupied by *Gardenias* planted out, and overhead quantities of *Stephanotis* flowering and in the best of health. Another house is planted with white *Camellias*, which look well set with flower buds, and promise to bring thousands of bloom in due season. Other houses are devoted to the cultivation of Ferns, Palms, *Dracenas*, and similar furnishing plants. Tea Roses are largely grown in the spring, and

Tomatoes, Cucumbers (Telegraph), Melons (chiefly Golden Perfection), occupying the houses during the summer months. There are about 600 plants of Chrysanthemums growing on in their flowering pots on the upright or natural system, staked and tied up to wires strained to posts in the orthodox way, one long row in front of a lean-to house facing the entrance, the others running between the houses at right angles, the whole embracing the best of the established varieties and a large number of new ones, many of them introduced by the firm, some of which were honoured with a first-class certificate from various societies last season. The plants looked very promising with stout hard wood, and should evidently repay with fine blooms for the time, care, and attention that very few trade growers care to bestow on them. In an adjoining plot of land large breadths of dwarf Roses of the most approved sorts are grown for their flowers alone, and herbaceous and other plants for flowering later on in the season.

#### SWANMORE.

We move on by train to Botley, and change there by a branch line to Bishops Waltham, our destination that evening being Swanmore Park, which we reach after a very pleasant drive of about three miles from Bishops Waltham station. After leaving the quaint little town and the old Ivy-clad abbey, which is close to the station, we emerge into the open country, and branching away to the left from the main road that leads to Swanmore village we find ourselves in very narrow country lanes, and gradually rising higher until the entrance gates of Swanmore Park, the seat of W. H. Myers, Esq., are reached. Here we find our friend Mr. E. Molyneux and his amiable partner welcoming us in good old English style, the whole country around stretching away in the distance over woodlands and pastures, forming a lovely landscape of park-like beauty. Mr. Molyneux's cottage at the entrance is overhung with Honeysuckle that fills the air with delicious perfume, the variety aurea reticulata looking more golden than usual under the influence of a strong July sun. The approach to the mansion is by a carriage drive through an avenue of overhanging young Lime trees. We diverge by a path to the left, and enter the garden by a door in a walled-in enclosure, in which are arranged the office and sheds situated at the back of the range of lean-to vineries, &c., that face the kitchen garden the other side. There are also two or three small span-roofed houses, Cucumber pits, frames, &c., in this enclosure, and on the spare space at the sides are growing the main batch of Chrysanthemum plants. They are arranged in rows 6 or 8 feet apart, so that plenty of light and air can reach them, and faced with a row of the dwarfest varieties beside the crescent-shaped path, which gave a finish to the whole group. The tallest are on the sides of a path in an adjoining kitchen garden, and which forms quite an avenue, as is represented by the woodcut in Mr. Molyneux's book. Ample provision is made to support these against the violent autumn gales by stout posts and strong wires, the topmost wire being about 10 feet from the ground, the height of the plants at the time of our visit, July the 9th, varying from 1 foot 6 inches to 7 feet 6 inches, the dwarfest being Madame Hoste and Madame Rozain, and the tallest Belle Paulc, Madame C. Audiguier, Mrs. J. Wright, Lord Wolseley, and Prince Alfred. The whole without exception looked in the best possible health and condition, with stems as stout as walking sticks, and stout leathery foliage covering the soil on the shortest plants, and to within a few inches on the tallest, which was a proof of the care that had been bestowed on them from the cutting pot, and which no doubt will be continued to be bestowed until further honours have been won. There is not a weak or sickly plant amongst them, and taking them collectively they are the finest plants we have seen.

In a span-roofed house close by a fine crop of Melons was hanging, the plants very robust and producing large handsome fruit, the varieties being William Tillery, Sutton's Imperial Green-flesh, Hero of Lockinge, Golden Perfection, and the old Scarlet Gem. Here are also some furnished and highly coloured Crotons, each one the *beau idéal* of a good table plant. The varieties most in favour are *C. aneitiensis*, *C. sinizianus*, *C. elegantissima*, *C. angustifolius aureus*, and Countess. In a similar house there are the best varieties of Zonal Pelargoniums just throwing up some fine trusses. These span-roofed houses are utilised in the spring for striking and bringing along the Chrysanthemums before being placed out of doors. In an adjoining lean-to pit was a very heavy crop of Tender and True Cucumbers. The larger range of houses facing the garden consists of vineries, stoves, Peach house, and greenhouse. The first vinery, in which is growing a mixed collection, deserves especial mention, not only on account of the splendid examples of Grapes they are carrying, but for the fact that all the roots growing in the inside border were lifted last year without any apparent check on them whatever. Well as the crop looks this year, it would be reasonable to assume that, when the roots get fairly hold by the new soil next year, they will be stronger than ever. They are now carrying heavy and well-proportioned bunches varying from 4 to 6 lbs. in weight on the larger varieties, and the others in proportion. Madresfield Court looks well, and not a cracked berry in it; Gros Colman, Alicante, Black Hamburgh, Gros Guillaume, Mrs. Pince, Trebbiano, with nine very large bunches, one measuring 20 inches by 16, and weighing quite 7 or 8 lbs. in weight, and Lady Downc's. The adjoining house is devoted to Muscat of Alexandria, also carrying a good crop of well-proportioned bunches, swelling and likely to be well coloured. It is in these two vineries the Chrysanthemums are housed and flowered in due season. Near the other end of the range is a fine healthy tree of the Pine Apple Nectarine, just ripening about 800 fruits; the tree in a short time will occupy the whole

house, another one by its side being gradually cut away to make room for it.

The centre part is devoted to the stove plants, some specimen foliage and flowering plants almost getting too large for the house. The Crotons are more remarkable for their high colour than for their size, although one fine specimen of *Croton variegatus* measures over 6 feet across. There is also a fine plant of *C. angustifolius*, and a splendid piece of *C. Queen Victoria*, very bright and telling; *Alocasia macrorrhiza variegata*, with more variegation in it than usual, perhaps on account of being in rather small pots considering the large size of the plants; and a fine plant of *Latania borbonica*, among other Palms, spreading out their large fan-like foliage over the pathway. The back wall of the stove is covered with a combination of Ferns, Palms, Begonias, and other ornamental foliage plants planted out, which overhangs and gives a sub-tropical and characteristic appearance. We notice two very nicely furnished specimens of *Bougainvillea glabra* full of flower. The greenhouse was gay with a varied collection, some very good plants of Tuberous Begonias, single and double, and one or two fine plants of *Trachelium caruleum*, which is grown to specimen size.

The outside garden is replete with beds and borders of annuals and herbaceous plants, of which there is a good representative collection. There are also some striking examples of the more modern style of bedding; some good beds of crimson single Begonias that were kept shaded from the scorching rays of the mid-day sun by light tiffany were just coming into flower, and promised to be very effective by the cooler autumn months. Another very effective bed was planted with a groundwork of the grey-leaved *Antennaria tomentosa*, and individual plants of *Lobelia cardinalis* dotted over it. It looked very pretty, the contrast between the light and dark foliage, but when the *Lobelia* gets at its best we could imagine the effect of the deep crimson flowers over the grey groundwork. The carpet beds were neat and well done, *Alternanthera nana aurea* being very bright and neat. It is certainly the best of the yellow foliage ones. There are other beds of great variety and various styles, foliage plants and succulents being used to break the monotony of the carpet beds, giving colour without gaudiness, and elegance and variety to the whole. Near here we notice a fine specimen of the Tulip Tree, *Liriodendron tulipifera*, quite 60 feet high. A pool of ornamental water, surrounded by rockwork and crossed by a miniature bridge, looked cool and delightful in the summer months, and formed a congenial place for aquatics and alpine plants.

In the kitchen garden we notice the Gooseberry and Currant bush trees, carrying very heavy crops of fine fruit, pruned on what we might call the extension and spur system—that is, long branches and very few of them, the side shoots spurred back to admit plenty of light and air; they were certainly heavily laden with fine fruit, which bent the branches down and gave them rather a straggling appearance. Outdoor Strawberries do not succeed well here; they have been tried in all positions and under all treatments, but they fail to produce a satisfactory crop. No doubt the chalky nature of the subsoil is the cause of it. A fine specimen Fig tree is growing here in full fruit, such as one rarely sees even in the south of England. A fine assortment of flowering shrubs and Conifers is growing in the shrubberies by the lawns, and the mansion will soon be clothed with Ivy and other creepers. The park as viewed from the lawn includes some fine specimens of Beech and other forest trees, and the already extensive estate have been added to lately by the addition of some surrounding property, on which extensive plantations of Larch trees have been made, as many as 187,000 having been planted within this last three years, which at the time of our most enjoyable walk round the estate was thriving and doing well in spite of the unfavourable season. These, and all the erection of houses, walls, rockeries, and the remaking and renovating of the fruit and kitchen gardens, lawns, and shrubberies, which the much-respected proprietor has had done since he came in possession of Swanmore Park, have all been carried out under the personal direction of Mr. Molyneux. The whole of the estate does him great credit, the work being kept well underhand, so he has had something on his mind beside Chrysanthemum growing.

#### SOUTHAMPTON.

Our next halt is at Southampton. We visit a relative at Shirley who grows Strawberries and a few other fruits for market, which are sold in the town. A striking contrast here to the soil of Swanmore, as far as Strawberry cultivation is concerned. On the somewhat limited plot of ground the fruit was lying around the plants abundantly, and smelt at the distance, under the scorching rays of the sun, like a jam factory, the drought causing them to ripen off prematurely, and consequently there was not half the weight in fruit as there would have been in a favourable season. The variety cultivated is Sir Joseph Paxton. They are grown in a most unorthodox way, and some of the beds that is now in full bearing having been planted eight years, and one plot that is going to be destroyed this year have been there ten years. So well does the soil suit them the land gets no preparation beyond digging and laying up rough for a time, and the young plants transferred with a spade or a trowel from the other beds. It was so different from the ordinary practice that we question our venerable friend—"But don't you manure or top-dress?" we ask. "If we were to do that we should get all leaves and no fruit," was the rejoinder. "Why, I have stood here on the edge of the path and picked half a bushel of fruit at a time without moving in a favourable year." We looked, and believed it, the condition of the plants and the crops showed it. But all our teaching on the orthodox system of growing and renewing Strawberry beds was floored, another instance that circumstances entirely alter cases. Truly

gardening is never learnt. I should mention that the soil is a deep rather dark sandy loam, and the position very little above the level of Southampton Water.

While in the neighbourhood we make a call at The Firs, Bassett, the residence of Mrs. Pearce, whose gardener, Mr. Wills, is well known as an exhibitor of stove and greenhouse plants at Southampton and other south of England summer exhibitions, as well as of Chrysanthemums, both cut blooms and specimen plants in the autumn, and considering the facilities he has for growing them, his productions do him an immense amount of credit. He has about 400 plants of Chrysanthemums on the upright or natural system from 2 to 7 feet high, with plenty of substance to produce some good flowers. He has about fourteen specimen Chrysanthemum plants growing, well furnished, and looking very promising. The span-roofed house wherein he flowers them is now producing a splendid crop of Hackwood Park Tomatoes. Amongst his specimen stove and greenhouse plants we noticed a fine plant of *Statice profusa*; *Clerodendron Balfourianum*, splendidly flowered; some good Crotons, Warreni, Prince of Wales, Queen Victoria, and Disraeli. A fine specimen of *Crossandra undulatifolia* attracted our attention. It is a hardwooded stove plant with very striking buff-coloured flowers, reminding one of a *Thunbergia*. Overhead in one of the plant houses is trained a plant of *Stephanotis floribunda* full of flower, and bearing a green pod of fruit about the size of a large Lemon. There is a good collection of Orchids here, and Fuchsias and Tuberous Begonias are also well done, besides the many other plants under the charge of Mr. Wills. After spending a very enjoyable day we return home via Winchester well pleased with our "Holiday in the South."—C. O.



#### KITCHEN GARDEN.

**MUSHROOMS.**—Of late these have been very plentiful in the fields. There was no appearance of them so long as the weather kept dry, but immediately after the rain they came up thickly, and many secured large quantities of them; but the field Mushroom season is short, and they are now scarceer than they were ten days ago. Some of them may be preserved in various ways, but these will never keep up the winter supply with any satisfaction, and beds should be formed as soon as possible for this purpose. Excellent crops may be secured from properly made beds in the open air, and those who cannot place faith in this system in winter may grow them in any cool shed, stable, cow-house, or, in short, an outhouse of any kind; we prefer these to heated structures. Horse droppings should always form the bulk of the material for the beds, but they may be mixed with leaves or loam, or both, at the rate of one barrowload to three of droppings. Dry soil is first rate for mixing with the manure when it is rather damp, and leaves increase the bulk of the material to make a large bed. It is an advantage when the droppings can be collected apart from the long straw manure, but we have made some good fruitful beds from the short material that was left over when the bulk of the manure was taken from the heap in the stable yard. Turn it and dry it until it is not spongy, then make up the bed in a compact form and very firm. Insert the spawn when the heat is at 90°, and soil over immediately afterwards. We have found it a good plan to sprinkle a little sand over the surface of the soil before making it firm and smooth with the back of the spade. Do not allow beds formed some time ago to become dry on the surface. A little damp hay placed over the surface will keep it moist.

**AUTUMN-SOWN CABBAGE.**—These do not grow very fast; we have seen them make more progress, and the slugs and snails are devouring many of them. The blanks should be filled as often as they occur, and sprinkle a little lime or soot amongst the plants frequently. In wet weather it is necessary to do this almost daily until the plants become a good size. A little sawdust placed round each will also save them. Plants that are very late in the seed bed may be supplied with guano water. The whole of the early spring Cabbages should be planted out before September is over.

**CAULIFLOWERS.**—Veitch's Autumn Giant is now turning in capitally. It is the best of all from now until November. Clear away the old roots as soon as the heads are cut. Now is a good time to sow Cauliflower seed to secure plants that will stand the winter and be planted out next spring. They are sometimes sown earlier than this, but we prefer small plants in winter to very large ones. When they are large they become so leggy during the short days, and they often flower prematurely in spring. Such plants, too, require much space during the winter, which is not a recommendation. Our plan is this: put a two-light frame down in a sunny spot in the kitchen garden, fill it to 10 inches from the glass with good soil, and sow the seed here. Do not put the lights on, but allow the seed to germinate and the plants to grow without protection until frost comes. This will make them very hardy at the beginning, and when the lights are put on the plants will be so

near the glass that they will not be drawn, but they will remain compact as seedlings in the seed bed all the winter, and be in fine condition for planting in the spring.

**PARSLEY.**—Although many vegetables have been scraggy and grubby this season, Parsley, which suffers so often, is very good, and it is still abundant. It may go back when the bad weather comes, and it is always well to be prepared for this. Should some of the lower leaves be brown or yellow pull them off and send them to the kitchen to be dried for winter seasoning. It is better to depend on young green growths from now onwards than trust to those that are fully grown. Hoe well between the rows, and if there is any danger of grubs becoming troublesome dust it heavily with soot; in fact, it is a good plan to apply this as a stimulant or fertiliser whether the grubs are there or not.

**WEEDS.**—Where weeds were allowed to seed during the hot weather the bad results of it are now being shown, as swarms are coming up, and late as it is they grow fast and will soon make the ground quite green. This is very undesirable and unprofitable, and the sooner they are destroyed the better. When the soil is moderately dry on the surface, run the Dutch hoe through them and root every one of them out.

**SURPLUS PLANTS.**—Where Broccoli and Savoys are raised in beds the best of the plants are generally drawn out from time to time during the season to plant in the main quarters, but there are generally some left over, and there may be quantities now in the beds. They will do little good where they are, but if drawn up and planted in vacant ground, which is now plentiful, they are almost sure to gain a useful size, and all who are likely to be deficient of green stuff during the winter or next spring should attend to this.

**MUSTARD AND CRESS.**—These do not grow freely in the open now, and where they are in demand the seed must be sown under glass. At this time of the year and on throughout the winter we always sow the seed in shallow cutting boxes, which can be placed in corners here and there under glass, and the supply is always good and certain.

#### FRUIT FORCING.

**VINES.**—*Midseason Houses.*—Vines from which the Grapes have been cleared should now be divested of their laterals down to the principal buds, which are to be retained for next year's fruiting, doing so, however, without injury to the old leaves, as upon their preservation depends the maturation of the buds, which should be plump and well ripened. A free circulation of air is necessary, and in the case of young Vines, or where there is the least doubt about the thorough maturity of the wood, fire heat will be necessary. When the laterals have been removed the old mulching should be cleared off the borders and a top-dressing given of turfy loam with about a sixth of manure and a sprinkling of half-inch bones. If the roots have not penetrated the mulching remove the soil down to them and replace it with fresh compost, but not covering them deeply; 2 or 3 inches depth is quite sufficient. In the case of inside borders afford a moderate watering, and allow those outside to have the benefit of October rains, and instead of adding manure to the loam mulch the surface with 3 or 4 inches of fresh horse droppings, covering with dry litter or bracken by the end of October or early November. In the case of borders only partly made a breadth of 2 feet may be added to the front, choosing a dry day for the operation, mulching with horse droppings, and covering up as before advised.

*Late Muscats.*—These will now be thoroughly ripe; if not, continue rather sharp firing in the daytime with a free circulation of air, and enough at night to prevent the deposition of moisture on the berries. Continue this until the Grapes are thoroughly finished, when a gradual reduction of temperature must take place, about 50° at night being necessary for Muscats after they are thoroughly matured. Moisture must be kept down by a buoyant atmosphere, a pent up air with a sudden increase of warmth from sun being sure to induce moisture to condense on the berries, which will cause spot, and then the Grapes will speedily decay. The inside border should be covered with clean dry straw or matting to prevent moisture arising.

*Late Grapes.*—These are liable to give evidence of finish that will bear a close scrutiny, therefore make sure that the berries are well finished quite up to the shank before ceasing the needful aid from fire heat. Alicante and Lady Downe's invariably finish better than Mrs. Pince, Gros Guillaume, and Gros Colman, rather the latter require more time, as also do the white varieties, Syrian, Trebbiano, and Calabrian Raisin; indeed all thick-skinned Grapes require a long time to mature after being apparently ripe, consequently a temperature of 55° should be assured, with a rise of 5° to 10° by day, and a circulation of air until the foliage is giving indications of falling, when a temperature of 50° will be sufficient. The inside borders must not be allowed to become too dry. If necessary, water in the early part of a fine day, and cover with a dry mulch as a safeguard against damp and a repetition of the watering. Outside borders will be quite damp enough, and should be covered up with lights preferably, or some other means employed to throw off heavy rains.

*Late Hamburgs.*—These colour and finish when it is hopeless to do anything more with the thick-skinned varieties. They should have a temperature of 60° to 65° at night, and 70° to 75° in the daytime, with a circulation of air constantly, not allowing the borders to become dry, but giving a good watering if they are only partially advanced in ripening, and mulch with rather short dry material. Only restrict the laterals to prevent overcrowding, but after the Grapes are finished avoid



farther extension, yet not reducing the foliage much, as this assists Hamburgs to keep their colour.

*Houses of Ripe Grapes.*—Hamburgs and all the thin-skinned varieties of Grapes require frequent examination for the removal of decayed berries, damp being their greatest enemy. It should be prevented as much as possible by fire heat in the daytime, accompanied by free ventilation, allowing the house to cool before night.

*Young Vines.*—Vines planted this spring or in early summer will need every encouragement in keeping the foliage clean and healthy, also keep the laterals away from the principal leaves in order to their free exposure to light and air, especially those at the base of the canes, so that the buds to which the Vines are to be pruned may get thoroughly matured and the wood at that part thoroughly ripened. In order to insure the ripening of the wood maintain a genial warmth by day, and throw the house open at night.

*FIGS.—Early Forced Pot Trees.*—These should have the roots examined, and as it is not advisable to increase the pot room, remove a few inches of soil from the base of the balls, cutting back the roots, and replace with fresh fibrous loam, adding about a tenth of old mortar rubbish and a sprinkling of crushed bones, good drainage being provided. Remove the loose surface soil and replace with the above compost, adding a fourth of well decomposed manure. Afford a good watering, and place the trees where they can have plenty of air with shelter from heavy rains and frost.

*Planted-out Trees.*—Keep these drier at the roots, but avoid extreme dryness, and a drier condition of the atmosphere will tend to promote the perfecting of the growths. As soon as the latest trees are cleared of their crops keep drier at the roots and the house well ventilated in favourable weather. Any root-pruning or partial lifting should be done when the leaves show indications of falling.

#### PLANT HOUSES.

*Callas.*—These may now be lifted and potted. Preserve all the fibry roots possible, and if placed in the pots with fresh soil, one-third of which is decayed manure, they will be established and rooting freely again in about a fortnight. After potting give a thorough soaking of water, and stand the plants behind a north wall until they are sufficiently established to bear full exposure to the sun. For the first week after lifting syringe them two or three times a day during bright weather when the atmosphere is practically dry.

*Salvias.*—Lift and pot these also, but large pots are not necessary. These are quick free-rooting plants, and quickly become established. Pot them in good fibry loam and one-seventh of manure; the soil should be pressed firmly to prevent a soft quick growth after they are established. The same treatment advised for Callas will suit them well until they are rooting sufficiently to bear exposure to the sun.

*Bouvardias.*—Those that have been planted out may be carefully lifted and placed in pots. In the compost for these one-third of leaf soil may with advantage be added to the loam. These may be established under the same conditions as advised for Salvias, but we have found they commence root activity much more quickly when placed in cold frames if they are kept moist and shaded from the sun. Those in pots that have been plunged with the rims below the surface may also be lifted, and all roots that have extended over the surface and out at the base may be cut away. They will not suffer by this process if well soaked with water and then kept close, moist, and shaded in frames for a week or ten days. If it is desired to bring any of the plants into flower as early as possible select those that are in the most forward condition that have rooted least out of the pots, and place them in a temperature of 55° to 60°.

*Solanums and Eupatoriums.*—The last may be lifted and treated the same as advised for Bouvardias. If frame room cannot be accorded them they may be subjected to the same treatment as Salvias; they can be established by this method, but are longer. Solanums that have been grown in pots and plunged during the summer should be lifted, and the roots cut away that have passed into the soil surrounding the pots. If placed in frames they will bear full exposure to the sun in a week or ten days. They must be well watered, kept close and moist until it can be discerned that they are making fresh roots freely. If the berries are in a backward state place them at once under greenhouse treatment, but be careful not to allow the pots to stand upon a dry base, or the foliage may turn sickly yellow, and then the appearance of the plants is destroyed. To assist the plants to perfect their berries when well established apply a little artificial manure to the surface of the soil. Those that have been planted out should be lifted and potted firmly in good loam with one-seventh of manure, and then stood behind a north wall until they are established. Directly they are potted a good soaking of water must be given, and then be kept thoroughly moist until they are established.

*Zonal Pelargoniums.*—Plants that have been outside for winter flowering should be placed under cover as speedily as possible. The earliest and most promising may be placed in a light airy structure for the present, where they will gradually come into flower. The others may have the protection of cold frames. This is necessary only to shield the plants from heavy rains, which start them into rapid growth. This must be avoided, for growth made under these conditions is soft and unfit to yield a long profusion of bloom. The lights should be thrown off on all fine days, and well tilted at night, so that the plants have as much air about them as if stood outside. From these all the flower buds that are visible may be removed. They should also be

watered with greater care than was necessary during the past hot dry weather, for if kept too wet they will start into active growth, and under such conditions they might just as well be left outside. At the present time these plants are in excellent condition, with hard well-ripened wood, which will certainly flower well if carefully treated until they are allowed to unfold their blooms.

*Ivy-leaved Varieties.*—These must be under cover without delay, for it is useless to ripen them if allowed to make soft growth outside afterwards. At first they must have cool airy treatment in the greenhouse or in frames, so as not to unduly excite them, and when signs of movement are visible they should occupy a light position where a temperature of 55° to 60° at night can be maintained. This treatment will result in abundance of delicate flowers for cutting.

#### THE FLOWER GARDEN AND PLEASURE GROUND.

*Preparing for Frosts.*—Cold nights are now very frequent, and we shall be fortunate if no damaging frosts are experienced during September. If not already done, old plants needed for furnishing cuttings next spring ought at once to be potted up from the open ground. Zonal Pelargonium cuttings being very scarce, it will be necessary in most gardens to store the greater portion of the old plants. It will be unwise to leave these out till badly damaged by frosts, the tops being especially needed for making into cuttings next spring. They will not long remain ornamental in the beds, and their early removal will admit of the beds being replanted with spring flowering plants while yet the ground and the weather is favourable for the operations. Pelargoniums may be lifted without any soil about the roots, and be stored thickly in large pots or boxes of light soil, or they may be potted off singly into as small pots as they can be comfortably got into. As most of the old leaves will damp off, it is advisable to pick the greater portion of them at once. They should be set under glass and kept rather on the dry side till somewhat recovered; in fact, they ought to be only just kept alive through the winter, no active growth being encouraged before the spring. It is next to useless to lift Lobelias and Ageratums that are full of bloom and have no young growths on them. These rarely survive or give any cuttings. Bulbous or tuberous-rooted plants may be left in the ground till the tops are disfigured by frosts. Last season they escaped injury till near November, but this was too late for them to remain in the ground, and many Dahlias and Begonias especially were lost in consequence. All the Dahlias should be properly labelled before it is too late, or they are of little service for propagating purposes next spring. Seedlings, notably of single flowering sorts, ought to be gone over, and only the best marked for lifting, the inferior ones eventually going to the rubbish heap.

*Plants that Pot up Readily.*—Owing to the dryness of the season very many plants have not grown nearly as strongly as usual, and are only just flowering freely. Cold rains and frosts will soon spoil their beauty, whereas if a portion of them were carefully lifted and potted they would prove very serviceable either for decorating greenhouses and conservatories or for affording cut blooms in quantity. Dahlias do not lift well out of a heavy soil, this crumbling away wholesale from the roots, but out of lighter soils they transplant readily. Such comparatively dwarf sorts as Glare of the Garden, Cochineal, and Guiding Star are very effective in pots, and as they have not flowered much hitherto they ought to continue in full bloom for several weeks. We have at different times been successful in lifting and flowering even such tall sorts as Paragon, Juarezi, and Constance. The last-named is perhaps the most valuable of all Dahlias in a cut state, especially seeing how beautiful it is in wreaths and crosses. Mrs. Hawkins is also a favourite, and will be potted this season. They require rather large pots, or from 10-inch to 12-inch in size, the coarser growers sometimes still larger, and the potting should be done where the plants are lifted, as the soil is apt to crumble away in the course of a short journey to a potting shed. Set the plants in a cool house, shade from bright sunshine, and keep them well supplied with water—an overhead syringing on clear days also assisting them. Marguerites can be potted easily, or without experiencing a severe check. We select the sturdiest or most upright plants, placing them in 10-inch pots, and they continue to flower freely till well into the winter. Gaillardias picta and Lorenziana, if not grown to a great size, will also lift well and continue to yield their showy flowers for several weeks after. Stocks do not transplant well, but late Asters may be potted safely, and the blooms are in demand till such times as Chrysanthemums are plentiful. We have also been successful with small clumps of Japanese Anemones, Abutilons, Fuchsias, Plumbagos, Tuberous and other Begonias, and early-flowering Chrysanthemums; all can be potted safely, taking care in every case to shade them from bright sunshine till recovered somewhat.

*Transplanting Evergreens.*—Conifers and various evergreen shrubs move capably at this time of the year, and for several reasons we prefer to do as much as possible of the work of transplanting now, forming new shrubberies and re-arranging the old ones. At this time of year it often happens more men can well be spared from other work than is the case in the spring, and, moreover, the state of the ground favours the operations. When a tree or shrub is carefully transplanted thus early in the autumn they have time to partially recover from the check, and very frequently form fresh root fibre before cold weather stops all active growth. If placed in a good position, and always, if possible, in rather better soil than they were previously rooting in, they rarely experience a great check, and form good growth the following season. We find that not enough rain has fallen to well moisten the soil near the stems of the trees, and much sheltered soil is still quite dry a little way below the

surface. No tree or shrub ought to be moved in a dry state at the roots. A basin should be formed, opening out the soil near the stems in extent according to the size of the ball to be removed, and after this has been filled with water a few times the soil will be found well moistened to a good depth below. Never drag a tree or shrub out of its position. A good trench ought always to be opened out with forks around it and the tree well undermined, nor should a very large ball of soil about the roots be aimed at, these very frequently breaking away in large pieces. Pick away with a fork all unoccupied surface soil, and flatten the ball underneath while it yet rests on a small pedestal of subsoil. It can then be safely slid on to a strong board or barrow, and carried to a fresh site, and which ought previously to have been well and deeply dug. Mix leaf soil or spent manure with the surface soil. Always plant rather above the level. Carefully stake all newly planted trees. Deciduous trees not to be moved yet.

## THE BEE-KEEPER.

### NOTES ON BEES.

#### BEES VISITING ONE KIND OF FLOWER.

At page 195, "C. W. D." brings up the question afresh regarding bees visiting one kind of flower only in one journey. It is rare that bees work upon two different kinds of flowers before returning to the hive; it is the exception, not the rule. Still, I have observed this take place on more than one occasion. In the spring of 1886 I observed a bee first work upon a Crocus, then take to Arabis; but there was very little pollen of the former upon the thighs of the bee.

#### SWARMING.

At pages 194 and 195 "Felix" makes some remarks upon swarming that I do not agree with, or misunderstand. He is quite correct when speaking of "work being partially suspended for the day;" but when he speaks about the drones flying, "fussing about, anxious for the moment to arrive when the old home shall be deserted for a new shelter," I think he errs. Drones do not leave the old hive to join the swarm in great numbers, which I think is wisely ordained. He then says, "Eggs are placed in royal cells from four to five days before the issue of the swarm." Is this not an overdrawn picture? In all my experience I never saw nor heard of the queen bee laying an egg in a partially constructed queen cell. On the other hand, she tears to pieces every tenanted cell she has access to. Queen cells are raised by the bees around the egg laid at first by the queen in an ordinary worker cell. In fact, instead of the queen making any preparations for swarming, she seems mostly reluctant to leave the hive even after young queens are hatched and seems to prefer immediate death to abdication in favour of any youthful pretender. Moreover, I have witnessed the parent queen depositing eggs while the bees were in the act of swarming, which is strong proof that "the old queen does not lead the swarm." Very rarely indeed will a laying queen be allowed to exist where young princesses are running about.

"Felix," in speaking about young queens hatching or creeping out of their cradle, does not state what actually happens. Where many queens are brought forward in a hive, it happens more often than otherwise that the first-hatched queen is killed, unless when queens have been brought forward at an unseasonable or improper time. In that case the first-hatched queen is allowed full vent to her wrath to destroy every royal cell within the hive, and this she performs in tyrannical style. Instead of one queen only being allowed full freedom, I have very often picked out a dozen queens from casts, while from the sounds uttered within the hive there were as many running about. When so many queens are brought forward they

delay considerably the prosperity of the hive, and all surplus queens and queen cells should be destroyed on the eighth, or not later than the tenth, day after the first swarm has issued. It is wise counsel of "Felix" to remind bee-keepers to examine stocks containing young queens, to know whether the queen exists or is fertilised; but on the other points I disagree with him.

#### QUEENS DETHRONED.

I have from time to time given hints regarding the dethroning of queens regnant by stray ones, but the following is about as interesting as any I have recorded. A young fertilised Carniolian queen at the head of a very small nucleus of bees had already commenced to lay, and the bees to carry pollen briskly. As it had a scarcity of food I fed gently, thinking all was going well, until one day I joined one nucleus to another that had lost its queen, slightly altering its position and wholly its covering, which in a great measure interrupted the working of the bees and encouraged robbers—to such an extent that at one time I was anxious for its safety. But by-and-by they began to defend; still there was a commotion, indicating an encasement, but the nature of the whole affair suggested the prudence of letting it alone to settle its own battles.

On the following day, and on the eve of leaving home for some time, I was horrified to find, as I thought, the queen killed, surrounded by a few bees. She was greatly mutilated, and to my astonishment prettily striped, by far too much so for a Carniolian. I had examined her before, and could not recollect any unusual appearance about her. I dissected her and found her fertilised. I was almost disgusted with my hurried alterations, and instead of arranging my supposed queenless hive properly, and feeding it, left it uncared for—for what was the use of a few bees without a queen, and perhaps I had plenty without her? The first one I examined presented a pitiful appearance. The drones and workers were crawling in a dying state outside the hive. It had been robbed in so quiet a way that I never suspected anything wrong until I examined the inside of the hive. The queen was gone, and an attempt to raise a successor had been made until sheer hunger put a stop to the work of the bees. Two queens lost in one day was more, with other losses, than I had reckoned on, so I left next morning in the hopes that their places would be filled by imported ones; but the uncertainty of getting these at the time wanted impelled me to make fuller arrangements to breed pure queens in this country, if spared until another season.

On my return home after two weeks' absence, my joy was greater than my grief had been when I viewed the hive that had the defunct queen working extra well. I examined it, and found not only eggs and brood in all stages, but the original Carniolian queen healthy and unscathed. Where, then, did the dead queen come from? This was not difficult to answer. Surely from the robbed one. But why was it so beautifully striped with yellow? Had I not handled the original Carniolian queen, knew her, and saw her laying? Certainly. The mystery, however, was soon cleared up when I recollected the numerous queens that were flying about in July. One of the Syrian queens, from a Syrian cast, had entered the nucleus hive after its queen had been laying, but was deposed by the young Syrian, who was in turn fertilised, and left its own hive when it was being robbed, and attempted to again establish itself at the head of another hive. The above remarkable case shows how bee-keepers may be disappointed by such freaks—deposing, perhaps, an imported queen.

Still more remarkable is the following. On the night previous to taking my bees to the Heather I removed from a good stock of Carniolians 60 lbs. supers, using carbolicised paper to free the supers from bees; but so slightly impregnated was the paper that it scarcely sufficed for the purpose. All the work was performed from the back of the hive, and I could not see the front. After the supers were removed I attempted to make a crate take the place of the supers, when I found it rather large. It was raining, and had been nearly all day; still, chance robber bees were about, so to prevent the bees of the hive crowding its top and getting wet, and to prevent robbers, I laid the papers upon the top of the frames and replaced the roof until I slackened the crate so that it would fit. On coming out I removed the roof and dropped the crate in its place, but forgot to remove the paper. The odour from the carbolic by this time would be well volatilised. I packed all up and left for an hour, when passing the front of the hive I was surprised to see an enormous cluster of bees in front of the hive and under. My first thought was the carbolicised paper had sent the bees out of the hive; but then there was so little carbolic acid on it that it was impossible to do so, and more particularly when the paper lay upon the closed centre of the hive, which I discovered when I lifted the crate already well crowded with bees. It was replaced, and without examining endeavoured to get the outlying bees into the hive; but it was easier said than done, until I discovered a large cluster underneath the floor, which I caught in a crystal and placed the bees on the alighting board, when they made an attempt to enter. Then such a row took place I never before witnessed, while the heat of the hive was greater than any I had ever felt. The running out and in of the bees showed the queen was encased, and long after it was dark the bees were excited and flew out of the hive never to be seen, just as bees do when swarms are joined and the bee-keeper is deceived. I rose between three and four in the morning to find things as I fully expected—a heap of dead bees in front equal to a fair swarm, and the walks strewn with dead bees as if they had been put there with a shovel. The same have done well at the Heather, so they could not be its own bees; but where did they come from? Bees could not come from a distance the stormy day it was, and there were no lost bees in the neighbourhood. They were not Carniolians that were killed, and the stock they were killed at is one of the best on the moors. There is a mystery about it.

#### FOREIGN BEES.

As some of your correspondents are still sceptical of the superiority of foreign bees, I send the following from a correspondent:—Our season was too dry. The Clover was burned up just as it was coming into bloom; but the season for the Heather was fair. My seventeen hives in spring will average 50 lbs. or over, and increased to twenty-five stocks.

The small Syrian swarm I got from you two years ago has given me the enormous amount of 250 lbs., swarms and all.—A LANARKSHIRE BEE-KEEPER.

#### BEES IN A BOX.

IN the early part of July we were visited by a swarm of bees, and one of the men promptly "boxed" them, and they are in that box now—size, 16 inches by 13 by 10. They are placed on a stand and protected from the rain only, and being only novices in bee-keeping any advice from your experienced readers on the matter would be very welcome, as we are anxious to keep the swarm.—INQUIRER.



All correspondence should be directed either to "THE EDITOR" or to "THE PUBLISHER." Letters addressed to Dr. Hogg or members of the staff often remain unopened unavoidably. We request that no one will write privately to any of our correspondents, as doing so subjects them to unjustifiable trouble and expense.

Correspondents should not mix up on the same sheet questions relating to Gardening and those on Bee subjects, and should never send more than two or three questions at once. All articles intended for insertion should be written on one side of the paper only. We cannot reply to questions through the post, and we do not undertake to return rejected communications.

**LATE INQUIRIES.**—It is necessary to again remind correspondents that letters arriving on WEDNESDAY MORNING cannot be answered in the "next issue," which is then far advanced for press.

**Leaving a Situation (Journeyman).**—A week's notice is sufficient in your case.

**Ferns (Young Gardener).**—All the Ferns named will succeed in a house with a temperature ranging between 50° and 60°, or falling to 45° in winter will not hurt them. The Adiantums and Pteris can be readily increased by spores. The soil should never be allowed to become dust-dry, but when they are not growing and in cold damp weather they need very little water. Two parts light turfy loam and one of leaf soil will suit them if you cannot obtain peat. Give good drainage.

**Paris Daisy (M. C. B.).**—The plant you refer to is *Chrysanthemum frutescens*, but there are several varieties. We should prefer planting the Lilies, &c., in separate clumps, they would then show their special characters better than if mixed.

**Gathering Pears (Idem).**—It is not generally advisable to gather Pears before they come away when gently lifted. That is a good criterion if taken with an indication of their general appearance betokening maturity. All those you name should not be gathered until they part from the trees readily. Some varieties are the better for being gathered somewhat in advance of their ripening, as when left too long on the trees they are liable to lose juiciness and quality—as, for instance, Doyenné d'Été, Jargonelle, Williams' Bon Châten, Souvenir du Congrès, and Beurré Giffard, but the majority of the early autumn Pears should be in the condition indicated before they are gathered.

**Calla Leaves Spotted (A. Grant).**—The leaves are showing the effects of having been infested with an insect very similar to the Celery fly—viz., *Tephritis onopordinis*, which lays its eggs in or on the leaves, and the larvae produced feed upon the parenchyma of the leaves, forming blisters, which ultimately decay. The best preventive is to dust the plants with soot whilst damp, or syringe occasionally with soap-suds, which render the leaves obnoxious to the fly, and prevent it depositing its eggs. The remedy is to remove the affected parts and burn them.

**Lifting Gladiolus The Bride (W. A.).**—*Gladiolus Colvilli albus* (The Bride) is quite hardy in all but very unfavourable soils and situations, and for satisfactory results should not be lifted annually, but left in the ground protecting the roots with a mulch of some enriching material, as leaf soil, cocoa refuse, and partially decayed manure. Being of the early flowering section the corms should be planted before November, and if your soil is too wet and cold for them pot and keep them protected in frames over the winter, planting them out in spring.

**Saxifraga oppositifolia (Idem).**—This lovely plant is not suitable for growing in the shade, and is equally unfitted for rockwork facing the south, but on the northern slopes of rockwork, where it will be shielded from the scorching summer heat, having plenty of light and an abundant supply of moisture, it grows and flowers well in early spring.

**Peach Gregory's Late (C. G.).**—We have seen some very fine and excellently flavoured fruits of this variety recently, and the gardener spoke most highly of its merits. It is thus described in the "Fruit Manual":—"Fruit, large, ovate, and pointed. Skin, pale green on the shaded side, and with a dark red cheek, like Royal George, on the side next the sun. Flesh, very melting, vinous, sugary, and highly flavoured. Flowers, small. Leaves, with round glands. Ripe in the end of September or beginning of October. It is an excellent late melting Peach, somewhat later than Late Admirable. Does not colour or ripen well in ordinary seasons. This was introduced by Mr. William Gregory, a nurseryman at Cirencester, about the year 1849."

**Plants for Making-up Gaps in Hedges (S. S.).**—The wild Pear makes a very strong fence, and succeeds in exposed places. The Cherry Plum (*Prunus myrobalana*) is also excellent. Those we should advise preferably the first named, but both are good. It is necessary if you procure large plants that they have been recently transplanted.

**Conservatory Plants (R. B.).**—You will require few other plants besides those named in your list, as it is not desirable to crowd the roof too much. *Clematis indivisa lobata*, *Lonicera sempervirens*, and *Passiflora coccinea-racemosa* might, however, be added. *Kennedia monophylla* would also do well in a similar way. The Roses and *Lapagerias* will no doubt prove the most useful plants in such a house.



**Black Muscatelle Grape Unsatisfactory (B. B. D.).**—This Grape requires careful treatment. It requires to be started not later than March, and when coming into flower it should have a rather warm (70° to 75°) and dry atmosphere, the bunches being dusted carefully with a large camel-hair brush to insure thorough impregnation, taking pollen from other varieties as Black Hamburg so as to make sure, but the brushing is usually sufficient. Encourage a good spread of laterals, but not so much as to crowd the principal foliage. Feed well until the Grapes change colour, then afford a mulch of dry material over the border if inside, so as to keep down the moisture, and with a circulation of dry rather warm air the Grapes ought to finish satisfactorily. The only way to keep the Grapes from cracking is to preserve them from condensed moisture—a slight warmth in the pipes with a little air top and bottom will effect that object, increasing the ventilation before the sun acts powerfully on the house.

**Plants for Exhibition (J. S.).**—The following are the most serviceable plants you could grow for flowering during July and August:—*Allamanda grandiflora* (this should be grafted on some strong-growing kind, such, for instance, as that you possess), *Dipladenia amabilis*, *D. Brearleyana*, *D. insignis*, and *D. boliviensis*. If you only require one grow the second named, if two the second and third. *Ixora coccinea* when well grown is a telling plant; *I. Duffi* is very distinct with its very large trusses, and the same may be said of *I. Colei*, a white variety, but the trusses are small. If you only want one grow the first, if two the second also. *Franciscea calycina major* and *Aphelexis macrantha purpurea* would be valuable additions. There are large numbers of *Ericas* which flower at that season by retarding them early in the year if required for the last-named month. The following are six good varieties: *E. Aitouianna Turnhullii*, *E. Austriana*, *E. Farriana*, *E. Marnockiana*, *E. tricolor Wilsoni*, and *E. ventricosa grandiflora*. Foliage plants: *Davallia Mooreana*, *Gleichenia Mendeli*, *G. dicarpa longipinnata* (five or six other *Gleichenias* are equally good and useful), *Kentia Belmorana*, *Pritchardia pacifica*, *Cycas revoluta* and *C. circinalis*, *Alocasia Veitchii*, and *Anthurium Warocqueanum* are all good. *Crotons* are indispensable, such as *Countess*, *Queen Victoria*, *Morti*, and *Neumanni*. The last may be called an improved form of *Baron James de Rothschild*; in fact, it is a seedling from that variety, and possesses larger and more highly coloured foliage. If you have this variety and *Queen Victoria* then add the first and the third named.

**Names of Fruits.**—The names and addresses of senders of fruit to be named must in all cases be enclosed with the specimens, whether letters referring to the fruit are sent by post or not. The names are not necessarily required for publication, initials sufficing for that. Only six specimens can be named at once, and beyond that number cannot be preserved. —(J. S.).—Plum, Red Magnum Bonum. We do not recognise either of the Apples. (Rev. W. Gibbons).—It is impossible to give an opinion upon your seedling Apple at present. When you have kept it till it is fully ripe, and then send it to the Fruit Committee of the Royal Horticultural Society, you will receive an opinion as to its merits. (P. H. Wright).—1, Manks Codlin; 2, Greenup's Pippin. (James Birch).—Reinette de Canada. (Fritton).—1, Fondante d'Automne; 2, Duc de Bordeaux; 3, Passe Colmar; 4, Bergamotte Esperen; 5, Suzette de Bay. (William Bell).—Winter Greening. (J. Joyce).—1, Beurré Diel; 2, Beurré Diel; 3, White Doyenné; 5, Not known; 16, Beurré Amande.

**Names of Plants.**—We only undertake to name species of plants, not varieties that have originated from seed and termed florists' flowers. Flowering specimens are necessary of flowering plants, and Fern fronds should bear spores. Specimens should arrive in a fresh state in firm boxes. Slightly damp moss or soft green leaves form the best packing, dry cotton wool the worst. Not more than six specimens can be named at once. (L. F.).—*Alströméria chilensis*. (A Young Gardener).—1, *Adiantum gracillimum*; 2, *Adiantum assimile* (Australia); 3, *Adiantum formosum* (New Holland); 4, *Pteris serrulata* (Japan); 5, insufficient without spores; 6, *Phlebotium aureum* (Tropical America). We wish all our correspondents would take as much trouble as you did in sending specimens for name; they arrived in excellent condition, but No. 5 was too imperfect a frond. See reply above as to culture. (York Villa).—We think the *Cypripedium* is a light-coloured and pretty form of *C. barbatum*, the *Odontoglossum* is an unusually fine variety of *O. grande*, and the *Brassia* is an extremely large *B. brachiata*. (H. S.).—*Corydalis lutea*. (F. H.).—1, The flowers were too withered for identification; 2, 3, and 4 are varieties of *Erica ampullacea*; 5 is *Erica cerinthoides*.

**COVENT GARDEN MARKET.—SEPTEMBER 21ST.**

TRADE still quiet. Good samples of English Pears realising fair prices.

**FRUIT.**

	s. d.	s. d.		s. d.	s. d.
Apples, 1/2 sieve .. ..	1 6	to 3 6	Oranges, per 100 .. ..	6 0	to 12 0
Nova Scotia and .. ..	0 0	0 0	Peaches, dozen .. ..	2 0	6 0
Canada barrel .. ..	0 0	0 0	Pears, dozen .. ..	1 0	1 6
Cherries, 1/2 sieve .. ..	0 0	0 0	Pine Apples, English,		
Cobs, 100 lbs. .. ..	50 0	55 0	per lb. .. ..	1 6	0 0
Figs, dozen .. ..	0 3	0 6	Plums, 1/2 sieve .. ..	1 6	2 6
Grapes, per lb. .. ..	0 6	2 6	St. Michael Pines, each	3 0	5 0
Lemon, case .. ..	10 0	15 0	Strawberries, per lb. ..	0 0	0 0
Melon, each .. ..	0 6	1 0			

**VEGETABLES.**

	s. d.	s. d.		s. d.	s. d.
Artichokes, dozen .. ..	1 0	to 2 0	Lettuce, dozen .. ..	0 9	to 0 0
Asparagus, bundle .. ..	0 0	0 0	Mushrooms, punnet ..	0 6	1 0
Beans, Kidney, per lb. ..	0 3	0 0	Mustard and Cress, punt.	0 2	0 6
Beet, Red, dozen .. ..	1 0	2 0	Onions, bunch .. ..	0 3	0 6
Broccoli, bundle .. ..	0 0	0 0	Parsley, dozen bunches	2 0	3 0
Brussels Sprout, 1/2 sieve	0 0	0 0	Parsnips, dozen .. ..	1 0	0 0
Cabbage, dozen .. ..	1 6	0 0	Potatoes, per cwt. .. ..	4 0	5 0
Capsicums, per 100 .. ..	1 6	3 0	" Kidney, per cwt. ..	4 0	0 0
Carrots, bunch .. ..	0 4	0 0	Rhubarb, bundle .. ..	0 2	0 0
Cauliflowers, dozen .. ..	3 0	4 0	Salsify, bundle .. ..	1 0	1 6
Celery, bundle .. ..	1 6	2 0	Scorzoneria, bundle ..	1 6	0 0
Coleworts, doz. bunches	2 0	4 0	Seakale, basket .. ..	0 0	0 0
Cucumbers, each .. ..	0 4	0 6	Shallots, per lb. .. ..	0 3	0 0
Endive, dozen .. ..	1 0	2 0	Spinach, bushel .. ..	3 0	4 0
Herbs, bunch .. ..	0 2	0 0	Tomatoes, per lb. .. ..	0 4	0 6
Leeks, bunch .. ..	0 3	0 4	Turnips, bunch .. ..	0 4	0 6

**PLANTS IN POTS.**

	s. d.	s. d.		s. d.	s. d.
<i>Aralia Sieboldi</i> , dozen ..	6 0	to 12 0	<i>Fuchsia</i> , dozen .. ..	3 0	to 9 0
<i>Arbor vitae</i> (golden) dozen	6 0	9 0	<i>Geranium</i> (Ivy), dozen ..	0 0	0 0
" (common), dozen ..	0 0	0 0	" Tricolor, dozen .. ..	0 0	0 0
Asters, dozen pots .. ..	3 0	6 0	<i>Gladiolus</i> .. ..	4 0	6 0
Azalea, dozen .. ..	0 0	0 0	<i>Hydrangea</i> , dozen .. ..	9 0	12 0
Begonias, dozen .. ..	4 0	9 0	<i>Lilies Valley</i> , dozen .. ..	0 0	0 0
Capsicums, dozen .. ..	6 0	9 0	<i>Lilium lancifolium</i> , doz.	12 0	18 0
<i>Cineraria</i> , dozen .. ..	0 0	0 0	" longiflorum, doz. ..	0 0	0 0
Creeping Jenny, dozen ..	0 0	0 0	<i>Lobelia</i> , dozen .. ..	0 0	0 0
<i>Dracena terminalis</i> , doz.	30 0	60 0	<i>Marguerite Daisy</i> , dozen	6 0	12 0
" <i>viridis</i> , dozen .. ..	12 0	24 0	<i>Mignonette</i> , dozen .. ..	3 0	6 0
<i>Erica</i> , various, dozen .. ..	9 0	18 0	<i>Musk</i> , dozen .. ..	0 0	0 0
<i>Euonymus</i> , in var., dozen	6 0	18 0	<i>Myrtles</i> , dozen .. ..	6 0	12 0
<i>Evergreens</i> , in var., dozen	6 0	24 0	<i>Palms</i> , in var., each ..	2 6	21
Ferns, in variety, dozen	4 0	18 0	<i>Pelargoniums</i> , dozen ..	6 0	12 0
<i>Ficus elastica</i> , each ..	1 6	7 0	" scarlet, doz. .. ..	3 0	9 0
Foliage Plants, var., each	2 0	10 0	<i>Spiraea</i> , dozen .. ..	0 0	0 0

**CUT FLOWERS.**

	s. d.	s. d.		s. d.	s. d.
Abutilons, 12 bunches ..	2 0	to 4 0	Lilies, White, 12 bunches	0 0	to 0 0
Anemones, 12 bunches ..	0 0	0 0	" Orange, 12 bunches	0 0	0 0
Arum Lilies, 12 blooms ..	3 0	6 0	<i>Marguerites</i> , 12 bunches	2 0	6 0
Asters, 12 bunches .. ..	2 0	6 0	<i>Mignonette</i> , 12 bunches	1 0	3 0
" <i>Freuch</i> , bunch .. ..	1 6	2 0	<i>Myosotis</i> , 12 bunches ..	1 6	3 0
<i>Bouvardias</i> , bunch .. ..	0 6	1 0	<i>Narciss</i> , 12 bunches ..	0 0	0 0
Camellias, blooms .. ..	0 0	0 0	" White, English, hch.	0 0	0 0
<i>Carnations</i> , 12 blooms ..	1 0	2 0	<i>Pansies</i> , 12 bunches ..	0 0	0 0
" 12 bunches .. ..	4 0	6 0	<i>Peas Sweet</i> , 12 bunches..	1 6	3 0
<i>Cornflower</i> , 12 bunches ..	1 6	3 0	<i>Pelargoniums</i> , 12 trusses	0 9	1 0
<i>Dahlia</i> , 12 bunches .. ..	2 0	4 0	" scarlet, 12 trusses	0 3	0 6
<i>Daisies</i> , 12 bunches .. ..	2 0	4 0	<i>Pinks</i> , White, 12 bunches	0 0	0 0
<i>Eucharis</i> , dozen .. ..	2 0	4 0	" various, 12 bunch	2 0	4 0
<i>Gardenias</i> , 12 blooms ..	2 0	5 0	<i>Poinsettia</i> , 12 blooms ..	0 0	0 0
<i>Gladiolus</i> , 12 sprays ..	1 0	1 6	<i>Primula</i> (single), bunch	0 0	0 0
<i>Hyacinths</i> , Roman, 12			" (double), bunch ..	0 9	1 0
" sprays .. ..	0 0	0 0	<i>Polyanthus</i> , 12 bunches..	0 0	0 0
<i>Iris</i> , 12 bunches .. ..	0 0	0 0	<i>Ranunculus</i> , 12 bunches	0 0	0 0
<i>Lapageria</i> , white, 12			<i>Roses</i> , 12 bunches .. ..	2 0	6 0
" blooms .. ..	1 6	3 0	" (indoor), dozen ..	0 9	1 0
<i>Lapageria</i> , coloured, 12			" Tea, dozen .. ..	1 6	3 0
" blooms .. ..	1 0	1 6	" red dozen .. ..	0 0	0 0
<i>Lilac</i> (white), French,			" de Mois, 12 bunches	0 0	0 0
" bunch .. ..	0 0	0 0	<i>Stephanotis</i> , 12 sprays ..	2 6	4 0
<i>Lilium longiflorum</i> , 12			<i>Tropaeolum</i> , 12 bunches	0 0	0 0
" blooms .. ..	2 0	3 0	<i>Tuberose</i> , 12 blooms ..	0 6	1 0
<i>Lilium lancifolium</i> , 12			<i>Tulips</i> , dozen blooms ..	0 0	0 0
" blooms .. ..	0 6	1 0	<i>Violets</i> , 12 bunches ..	1 0	1 6



**KEEPING A COW.**

MILK that comes in contact with anything offensive becomes tainted just in proportion to the quantity or character of such material. This would appear so self-evident that mention of it may seem superfluous, but it should be clearly understood that the contamination may arise from foul odours equally as from contact with dirty utensils. Hence, therefore, the importance of keeping the cow house clean as well as the dairy; and the advice that before a cow is milked due care should be taken that the udder, teats, milker's hands, and the milking pail are all clean, is anything but superfluous. Not only should a milker wash his hands before milking, but he should also keep the nails well pared, for long finger nails often cause sore teats.

Regularly at morning and evening the milking must be done thoroughly, for upon this depends very much the maintenance of as full and steady a yield of milk as is possible. Seldom indeed is it that three milkings a day are required, except for a day or two just after calving to relieve the udder, and in the exceptional case of a very deep milker. We cannot make such an extraordinary demand upon Nature with impunity unless we take care that the cow is especially well fed. But such deep milkers, however well fed, are generally comparatively low in condition. There is the abnormal development of milk veins and udder, but the frame is devoid of that fleshy condition in which we like to see all healthy animals.

There is much difference in the quantity of milk given

by different cows, the size of an animal being no guide in the matter. For example, we have had sixteen quarts of milk daily from a little Kerry cow, while a big Shorthorn gave only ten quarts. We may take the average yield of an ordinary cow at twelve quarts, which if of fair quality will produce about 1 lb. of butter; or, to put it in another way, we may say that a quart of rich cream gives 1 lb. of butter, but if at all inferior in quality it will not do so. The milk is kept in pans of earthenware or glass from twenty-four to forty-eight hours—the shorter time in summer, the longer in winter—care being taken to strain it when formed into the pans to remove hairs and particles of dirt. Some dairywomen prefer shallow tin pans, especially in summer, when it is important to induce the cream to rise quickly before there is risk of souring, which stops the rising of the cream.

Among the hints for dairy management distributed by the Munster Dairy School we may usefully quote the following. Dairies should be kept perfectly sweet and well ventilated, and be separated by a partition wall from the dwelling house. No door or window should look out in any yard or place whence smells of any kind could come. The floor should be flagged, tiled, or cemented, so that it can be frequently washed: an earthen floor, damp and dirty, is most unfit for a dairy. Any splashes of milk should be immediately wiped up, as if allowed to remain and turn sour they will taint the milk. The windows should be arranged so that no streaks of light or sun should shine upon the milk, as they produce flecks in the cream which always show in the butter. Dairy utensils should be cleaned by first washing them in cold water, then scalded, and again washed in fresh cold water. The temperature of the dairy is most important; it should never be allowed to go under 50° or over 55°.

The cream for churning should not be kept too long. Slight ripening is good for the butter, but it should never be allowed to become very sour, and in winter should be churned at least twice a week, and in summer more frequently. It should be kept covered with muslin, both to exclude particles of dust, and also to prevent the air acting too much upon the surface of the cream and produce unequal ripening. In adding a fresh skimming the contents of the crock should be well stirred, so as to mix all well together; and no fresh cream should be added for twelve hours before churning, as it would not have time to equally ripen, and would take longer than the other cream to churn, so that the churning would be stopped before the butter came on the fresh cream. The temperature of the cream before churning should always be carefully tested with the thermometer. It has been proved that 57° is the best temperature to churn at; and the cream in cold weather should be warmed to this by placing it before a fire or in a tub of warm water, or in hot weather cooled by placing it in cold water. The churn also should be rinsed out before churning in winter with hot water, in summer with cold.

The churn should be turned slowly at first, so as not to break up the butter globules too much, and the churning should be most carefully listened to and stopped the moment the butter comes, so as not to allow it to collect in lumps. The grain and firmness of the butter are thus preserved, and the buttermilk can be easily removed. After removing the buttermilk the butter should be washed in the churn, three times in fresh spring water, and twice in pickle, made by placing some salt in a piece of muslin on top of a can and pouring cold water over it. If the butter is at all soft it should be allowed to stand for a couple of hours in the churn in very cold water. In making the

butter handling should be most carefully avoided. By the use of a butter worker and butter slices, butter can be made without even touching it with the hands, and this is the plan adopted in the best dairies in England and on the Continent.

We do not of course intend to imply that a separate building is required for the milk of a cow or two, but rather to show the chief points of importance in a dairy in order that they may be brought to bear upon the selection and arrangement of any room for the purpose. The utensils required for a very small dairy are few and simple—a box churn, butter worker, pair of butter slices, or spatulæ, one or two pat stamps, skimming dish, cream bowl, cream crock, milk pans, strainer, and milk pail.

ERRATUM.—In the second paragraph on page 242, last week, beginning thus:—"Where land can be had there should always be a crop of Winter Oats," it should be Winter Tares.

#### WORK ON THE HOME FARM.

Wheat-sowing is now being done as fast as possible, every acre sown this month being worth two sown in October, having regard to the safety and certainty of the crop. We sowing much more Wheat upon our heavy land than we have done hitherto, for with the sale of straw, in addition to the grain, it answers very well, and winter corn is always a more certain crop than spring corn upon such land. If we were disposed to indulge in the proverbial farmers' grumble it would certainly be at the low price of Wheat, not only as affecting our own results, but as affording tenants an urgent plea for a farther reduction of rent. Our first sample of Barley sold for 36s. per quarter, and we believe high class samples will command paying prices. At the same market, however, we were offered a sample of large coarse discoloured grain for 20s. per quarter, and it would certainly have been to the grower's advantage if he could have kept and used it for feeding pigs.

Notwithstanding the loss of Clover plant there will be plenty of green food of one sort or other for use next spring and summer. Both Rye and Rye Grass have come up thickly; Trifolium, too, is a good plant, and with a succession of Tare crops we shall manage well enough. The loss of Red Clover is not a total one; we have a full plant on some layers, but on others it is difficult to find a plant at all. Lucerne and Sainfoin have borne the drought admirably, and we shall gradually add to the area of land under these two excellent forage crops.

The farmer whose land is badly infested with couch grass after three hot dry summers, such as we have now had, ought not to have an acre of land entrusted to him. Greatly did we deplore the sad sight of Twitch, Thistles, and Wild Oats which we have found upon the stubbles of some land of which we had to make an inspection recently. Our remonstrance about this matter with an outgoing tenant led us to point out the loss he had incurred in fertility stolen from his crops, and the risk he ran of litigation on the part of the landlord, who, under the Agricultural Holdings Act, had a clear case of a claim for compensation for land foul with weeds and exhausted of fertility. If through such negligence a prospective tenant declined hiring the farm, the claim would probably be enforced.

#### METEOROLOGICAL OBSERVATIONS.

CAMDEN SQUARE, LONDON.

Lat. 51° 32' 40" N.; Long. 0° 8' 0" W.; Altitude, 111 feet.

DATE.	9 A.M.					IN THE DAY.				Rain	
	Baromet. ter at sea Level.	Hygrome- ter.		Direction of Wind.	Temp. of soil at 1 foot.	Shade Tem- perature.		Radiation Temperature			
		Dry.	Wet.			Max.	Min.	In sun.	On grass		
1887. September.											
Sunday .....	11	29.939	56.4	51.6	S.W.	57.2	63.0	45.4	10.4	40.8	0.016
Monday .....	12	29.748	54.0	49.9	N.E.	57.4	62.1	51.4	112.4	49.5	0.013
Tuesday .....	13	29.807	50.1	47.4	N.W.	56.7	58.9	43.6	107.7	40.2	—
Wednesday ..	14	29.955	51.3	47.9	S.W.	55.8	60.8	44.1	103.2	38.6	0.010
Thursday .....	15	29.953	54.3	50.5	S.W.	55.8	61.9	49.3	108.5	46.2	0.116
Friday .....	16	30.091	57.2	53.3	S.	56.1	66.1	43.8	103.8	45.2	0.346
Saturday .....	17	30.113	56.8	56.0	Calm.	56.6	57.8	54.9	61.2	54.7	0.248
		29.937	54.3	50.9		56.5	61.5	48.4	101.2	45.0	0.749

#### REMARKS

- 11th.—Generally dull and windy with rain at 6 P.M.  
 12th.—Dull early, then fine and bright throughout.  
 13th.—Rain about 6 A.M., morning fine and generally bright; dull and overcast after 3 P.M.; fair evening.  
 14th.—Fine bright morning, as a whole, though somewhat threatening about 10.30 A.M.; afternoon very bright till about 3 P.M., then overcast; wet evening.  
 15th.—Dull morning with bright intervals; damp and showery afternoon; wet evening.  
 16th.—Fine and generally bright; fair evening with rain about 8 P.M., and again from 11 P.M.  
 17th.—Very wet early, foggy wet morning, very dark about 10 A.M. Rainy nearly all day.  
 A damp and cool autumnal week, the days being cooler relatively than the nights.—G. J. SYMONS.



## COMING EVENTS

29	TH	MICHAELMAS DAY.
30	F	
1	S	
2	SUN	17TH SUNDAY AFTER TRINITY.
3	M	
4	TU	
5	W	

## REMARKS ON HARDY FRUITS.

**W**E do not appear to be making much progress in hardy fruit culture if we are to take the recorded results of the present season as indicating the state of the gardening community in this matter. Repeatedly the very heavy crops and the drought combined have been blamed for the smallness of the fruit where it has remained on the trees, or for the casting of the fruit where it has fallen. This not only in the case of such a common fruit as the Apple, but the more select kinds, such as Apricots and Peaches, are said to have failed for the same reason. In most cases gardeners are powerless to do anything to mitigate the effect of the drought beyond indulging in a system of good cultivation, and perhaps mulching surfaces, but the neglect of careful thinning can surely be remedied. In most seasons the work is easily overtaken; this year the labour of thinning was greater, but the result well repays any extra work entailed.

This, which ought to be a matter of ordinary routine work, would seem to require pressing on the attention of gardeners. It is surely not to our credit that a season which ought to have been an overflowing one should be rendered a season of poverty either through inattention to one of the most apparent details of good fruit culture, or failing that reason, then through over-much greed to secure a large crop. The only way to arrive at a crop—large in all respects—is to thin betimes. Overlooked branches or trees have with us failed to bring their ‘load’ to a condition worth picking at all. This applies to all kinds of the larger fruits. Trees judiciously thinned have done their work to our satisfaction and with no harm to themselves. It may seem a very wasteful proceeding to pick off six or a dozen little fruits for every one left to swell and ripen, but it is not so. To leave more than the tree is able to bring to perfection is wasteful. To leave so large a crop as to tax the energies of the tree beyond a point of safety is to spoil the present and endanger the next year’s crop, and that is a wasteful policy. It cannot be too often said that too much fruit one year means less or none the year following. A tree has not only to produce a crop of fruit, but also to prepare for the crop that follows, or should follow. And just as surely as it fails to do so when over-cropping is allowed, just as certainly will it bear in continued succession if treated fairly. Everybody growing Grapes knows that to be a fundamental principle of good year after year Grape culture. With outdoor fruit it is ignored, and frosts and winds are blamed for what may be, and most likely is, only a perfectly natural result.

There is another matter in connection with good hardy

fruit culture which requires to be kept to the front. That is pruning the trees as soon after the crop has been all gathered as is convenient. This work is nearly always left till winter, sometimes until spring. But there is no time like the present for having the trees thinned and pruned. We do not prune Gooseberries, but Raspberries and Black Currants have been pruned and thinned. Red Currants are left till later, and so are Apples, the latter merely having any large branches cut out before the leaves fall, as the right distance to leave these can only be gauged correctly when the leaves are on the trees. Apricots, we find, do best spurred, and it takes a very short time to look over a number of trees and cut back, or cut out if necessary, any spurs that may require so treating. As already said, it is quite easy to note the right distances when the leaves are on the trees. Plums are treated in the same way, and also take up little time. Pears take longer, though only in the case of old trees; young ones necessitate very little work. A good method of rendering old Pear trees fruitful is to cut out the older and thicker branches and let young ones take their places. In a few years these young shoots are very fruitful. This treatment is sometimes quite as beneficial as root-pruning, perhaps more so. Next to cutting out branches altogether, it is of great importance to thin the spurs. Weakly spurs are not of the slightest benefit to the tree, and they give no fruit to the cultivator, therefore cut all such clean out, leaving only a fair number of strong healthy spurs, which are sure to bear. A few odd hours are very well spent in work as above recommended. It certainly is beneficial to the trees, and the difference between pruning, will ye, nill ye, in cold winter or spring days, and doing the same work in autumn, is a thing to be considered. Just now the work is pleasant and interesting.

One point in connection with hardy fruits is gathering Apples and Pears. I see very great mistakes made sometimes, even in the case of experienced gardeners. They make Apple gathering a question of mere routine; fix a day for the work to be done, and ready and unfit are alike put into store. My experience is that the individual characteristics of the varieties must be considered. Some do not much resent being gathered in a condition of unfitness, others do; but in the case of all the mere seeming is outwardly. Fruit not fully grown and finished on the tree can under no conditions be so good as that which has been well finished. With the earlier Apples and Pears the trees should be visited periodically, and those ready for gathering removed. Some of the, at first, smaller fruits will hang and swell for a long time, and be among the best when at last ready. The mere fact of a few Apples or Pears falling off a tree should not send one in hot haste to take the rest. By all means leave those which will hang. Fruit improves with marvellous rapidity in September and the earlier half of October. I have noticed Apples increase one-third in size in the space of a week. The last week or so also makes all the difference in the eating quality of both Apples and Pears. Cox’s Pomona and Reinette de Canada left to hang as late as possible, merely removing any likely to fall as they appear fit, are both improved in quite a wonderful manner. In Pears Marie Louise should be watched like a Peach. Beurré Bachelier, a handsome but not over well flavoured variety, may be made or marred by gathering. All varieties that ripen late we find are sweetest and keep better if left long on the tree. The old gardeners had a practice of burying their finer Pears in



heaps of heated manure in order to ripen them properly. I have been told by a gentleman, whose memory of the fruit may be somewhat vitiated by boyish incapacity to detect anything wanting in the flavour, that Pears thus treated were better than any he has now. Any way, there is no doubt that Pears may be wonderfully improved by a few days in a hothouse before using. An uninterrupted supply of good Pears may be kept up by this method, when if left to ripen naturally there would be gluts and scarcity.—A NORTHERNER.

### LATE PLANTING OF TREES AND SHRUBS.

LAST spring I had to carry out a rather extensive operation of lifting and transplanting a large number of trees and shrubs during the months of April and May—rather an unusual time of the year for that kind of work; but there were two objects in view. A certain space of ground had to be cleared for the purpose of throwing up a terrace and making a lawn at a lower level running on to a piece of water, which is to be enlarged, rendered ornamental, and brought into full view of the mansion. The shrubs were wanted for the purpose of making a private and ornamental approach to the church. Now, as the season was advancing beyond the time calculated to ensure the greatest success, and followed as it was by an unusual and prolonged period of dry weather, I thought it would be interesting and useful to others if I gave some particulars of the work and the success or the reverse of the different plants moved, and help to disprove the opinion held by many that transplanting

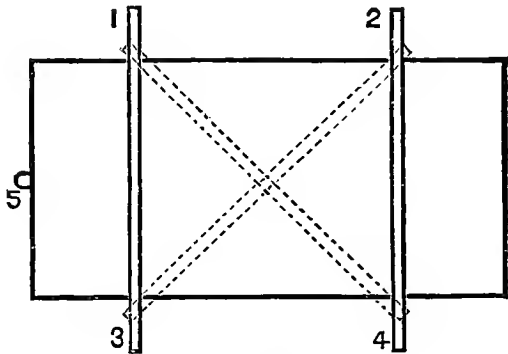

Fig. 34.

at that late part of the season cannot be attended with a satisfactory result.

The shrubs and trees included most of the leading ornamental kinds, deciduous and evergreen, usually found in an extensive pleasure ground. The soil in which they were growing, as well as that to which they were transferred, is a chalky loam resting on a bed of solid chalk, therefore procuring a good ball of soil to the roots was not always accomplished. They had been planted about seven years, and their height ranged from 4 up to 10 or 12 feet, many of them bulky in proportion. Each plant as taken up had its roots packed in mats, as it was some distance to carry them. The lighter ones were conveyed on a trolley or cart; the heavier ones, some of which weighed half a ton or more, were moved by a contrivance of our own, a rough sketch of which (fig. 34) I give with explanatory notes.

Seven pieces of 9-inch plank by 1½ inch thick strongly braced together, leaving projections 8 inches over, as shown by 1, 2, 3, and 4. In order to use this the tree should be pulled over, so that the ball shall lie on its side. The board is then thrust under the ball as far as it is possible to get it, braces uppermost. If put underneath these would hinder the plant, or, I should say, the board from sliding on the ground, and make the draft heavier by driving the earth before it. Then pull the plant upright, and it will place the ball nearly if not quite in the centre of the board. It is then bound on tightly by chains or ropes in the way the dotted lines indicate and around each projection. This gives stability to it and holds the plant in its place. The horse is attached to a hook at 5, and the plant can be drawn to its place comparatively easy.

The ground for the trees' reception was a piece of pasture, and the station for every plant set out and the holes dug at different depths and widths before a plant was moved, in order that when once taken up they should be put in without delay. All the deciduous kinds were taken first, as the buds on most were swelling fast. These chiefly consisted of Laburnums (20), Lilacs (17), Larch (19), Scarlet Chestnuts (8), Mountain Ash (7), Deutzias (15), Spiræas (14), double-flowering Cherry (8), several varieties of Thorns (21),

Maples (11), Limes (15), and Robinias (19). Out of the above number I lost three Larch, two Thorns, four Acacias, and one Ash. The evergreens were Chinese and American Arbor Vitæ, (50), Cupressus Lawsoniana (14), Cotoneaster microphylla (11), Green Box (9), Aucubas (7), Cryptomeria elegans (17), Yews, common and Irish (19), Hollies (23), Silver Firs (8), Spruce (19), Laurustinus (7), Portugal and common Laurels (30), Evergreen Oaks (17), Picea grandis (4), variegated and green Euonymus (11), Bays (17), Austrian Pines (25), Araucaria imbricata (4). Out of this number I lost three Arbor Vitæ, one Cotoneaster, nine Cryptomerias, two Yews, five Hollies, one Laurustinus, three Portugal Laurels, seven Evergreen Oaks, Berberis Darwini five, and three Spruce. All others in both sections not named as lost bore the ordeal of removal very well. Considering the total number of plants—over 450—the percentage of losses was not large considering the lateness of the season.

Those that have proved worst according to the numbers are Robinias, Evergreen Oaks, Berberis Darwini, and Cryptomeria elegans, which from their peculiar propensities of either striking down into the subsoil or out straight for some distance before making any fibrous roots, making it difficult to secure the roots intact. In my opinion such trees should have a preparation for some time previous to being removed. As a proof of this, six of the Evergreen Oaks had been dug round for removal six months previous, but were not wanted. These came out with a good ball, and did not appear to receive a check. Now a word about the planting. In this we were very particular. After each plant was put in its proper position and any straggling roots laid out, the sides of each hole were broken in with the planting, for I have proved it to be a very bad plan, whether in a light or heavy soil, to put a plant as it were into a basin and leave it so. In time the roots reach the sides and are unable for some time to penetrate it; the plant thus receives a check and perhaps dies. Therefore all was worked up together and made firm, each plant well staked and tied on two sides, and well watered. Every plant was either mulched with rough manure or grass, and as the weather was very dry our system was to water them every week.

Araucaria imbricata does not thrive here. A chalky soil is unsuitable, but the Austrian Pine is quite at home, makes a very ornamental tree, and bears the wind remarkably well. It should be noted that my trees were all at home—that is, grown on the estate, and the season being late by three weeks or more favoured the operation, yet I have found from experience that lots of our ornamental evergreen shrubs will submit successfully to removal at any time of the year if weather permits and they are not actually in full growth. Judicious treatment at the time and afterwards are requisite to success.—THOMAS RECORD.

### MUSHROOM GROWING IN A RAILWAY TUNNEL.

WHILE recently on a visit to Edinburgh I was invited to inspect a new venture in Mushroom cultivation on a large scale, and in what at first appeared to me a strange place—viz., the railway tunnel in Edinburgh, the entrance to which is in Scotland Street, the tunnel having been disused for the last twenty years owing to its not being considered safe for railway traffic. Last May a company was formed styling themselves the Scottish Mushroom Company, of which Mr. Thomas Handasyde was appointed manager, their object being to supply Mushrooms of the finest quality to the city of Edinburgh and neighbouring towns in competition with foreign produce, and judging from the start made the venture is likely to be a success. The total length of the tunnel is 1100 yards by 24 feet wide. It is estimated that 2000 tons of manure and soil will be required to complete the whole length of tunnel. On one side of the tunnel is laid a double line of metals upon which the engine and trucks travel. The manure is prepared in its first stages of fermentation in another place 500 yards away to avoid any nuisance to the city, and is then brought into the tunnel in railway trucks drawn by an engine belonging to the North British Railway Company, who are very obliging in assisting by all available means. The manure in a half-prepared state is deposited in heaps of 6 tons, the amount carried in each truck, where the final preparation takes place; the same with the soil used in covering the beds, that is brought in in the same manner and prepared as required. The first 200 yards of the tunnel is partitioned off with boards to prevent draught, which at certain times was found to be inconvenient in the working operations. The Company was fortunate in securing the services of Mr. B. Holmes of Clapham as grower, who had previously had considerable experience in the culture of Mushrooms. The first part of the tunnel was laid out in flat beds some 8 feet wide, and others 4 feet 6 inches, but are not considered to be so easily

managed, neither do they give so much surface space as the ridge-shaped beds adopted inside the partition. Such beds run crosswise of the tunnel, are 16 feet long, 3 feet wide at the base, 2½ feet high, and 1 foot wide at the top. Boxes of this shape and size are used to facilitate the formation of the beds, which they do, as treading the beds firmly is more easily accomplished by this means. Thus it will be seen that there were over 1100 yards of ridge-shaped beds, I having counted 210 in various stages. There were 1½ mile of beds formed, as much as 1400 tons of manure being in use at that time, much of the horse manure coming from the military barracks in the city. Many other kinds of material was being used for experiment, such as peat litter and cow manure, for instance. The beds were in all stages of formation, from the manure preparation, to formation of the beds, spawning the beds, soiling, covering with hay, to beds in full bearing—the crop being wonderful to behold; Mushrooms by the thousand in all stages of growth, from the smallest buttons to the finest full grown specimens—in one clump of a square foot was counted eighty-two Mushrooms. The spawn used is specially prepared for the Company. As much as 6 tons had already been used since the commencement in May last. Quite an even temperature could be maintained in the tunnel. Even through the hot summer just past it did not vary but little. Mr. J. Wright's book on Mushroom culture no doubt assisted the promoters of the scheme considerably. At the exhibition of the Royal Caledonian Horticultural Society, held on the 7th inst. in the Waverley Market Hall, a very fine exhibit from the Company in question was staged, as showing some of the results of this enterprise. In a Wardian Fern case, 3 feet long, and 1 foot 3 inches wide, groups of Mushrooms were to be seen in a growing state, as many as 130 being counted on a slightly raised mound in the centre, while the inside next the case was ornamented with hardy Ferns. About three dozen punnets containing Mushrooms in various stages of growth were arranged on a table adjoining this exhibit formed a very interesting feature in this excellent show.—E. MOLYNEUX.

#### LILIES IN SUN OR SHADE.

If I were asked the question unconditionally whether I considered shade beneficial to the well-being of Lilies generally, I should most decidedly answer in the affirmative provided that the trees supplying such shade were at a sufficient distance from the plants, so that their roots would not impoverish the soil in the Lily bed. But many might say, How can such statements be reconciled when many growers plant them in woods and in private gardens where fine trees are a leading feature? In the first place no Lily grower of experience would knowingly plant his choice bulbs close to Poplars or Elms, the roots of which travel superficially to a considerable distance, and especially on shallow soils. The best of all positions for Lilies is a cool shady border or bed which is not exhausted by the roots of trees. If a scorching sun will harm Lilies—and it does under certain conditions—then we have had sufficient sun and heat during this summer to test it. The conditions under which Lilies suffer in consequence of the tropical heat is when the surface soil of the bed is fully exposed to the drying influence of the sun. In this case the stem roots, which in some species render considerable service to the flower stems, soon perish. Invariably in private establishments *Lilium candidum* is found in the borders at the side of the broad walk in the kitchen garden, and in many cases the clumps are isolated. I have seen many thus this summer, and while having flowered freely for years previously have only produced a flower stem here and there, and these have perished before the flowers had time to expand. Upon examination I found that the bulbs had gradually risen near the surface, a circumstance to which they are liable after having occupied the same position for several successive years. The only conclusion that the gardeners in the cases referred to had arrived at was that it was the great heat. My own case ended in almost total failure, though the attendant circumstances were different, and were due to the neglect of the labourer, who, instead of planting them 6 inches deep as directed, in some instances little more than covered them. They did not flower according to my expectations last year, but being planted only in the year previous, and thinking they were hardly established, I did not interfere with them, and so made up my mind for a good season's flower in the present year. Had I searched for the reason at once I should have been able to supply a remedy, and thus saved a season's bloom. Last autumn with the rain the radical leaves came away strong, and I was well satisfied by the show of flower stems this year. These, however, had scarcely reached their usual height when decay again set in. The first item I discovered was the flower stems burst in many cases just above ground, continuing upwards to from 3 to 4 inches. I do not know what caused this, and may be some of your correspondents may be able to inform me. I imagined, however, that it was due to a superfluity of sap in that part of the stem, and which really had passed from the bulbs for developing the flowers, but which in many cases had fallen off, the bursting following as a consequence of expansion caused by the intense heat. The bursting in each case was on the side of the stem opposite to the sun. I next lifted a bulb for examination, and was surprised to find its apex only an inch below the surface; but regarding this as a bulb uplifted by moles which are some-

what troublesome, I examined several, only to find them in the same depth row for row. Here, then, was the secret of the failure.

Now for another experience. Planted on an adjoining bed to the *Lilium candidum*, of which I have spoken, are several varieties of *L. speciosum*, and including *rubrum*, *cruentum*, *Kratzeri*, and others. These are fully exposed, and without the slightest shade. They differ from *L. candidum*, however, by being planted thickly all over the bed, and not in rows 8 or 10 inches apart. By this style of planting the ground is completely shrouded by the foliage of the Lilliums, and as a consequence the ground does not, even under the hottest sun, feel the great heat; and throughout the summer under this dense shade it has been comparatively cool. It becomes very dry naturally if not watered, but even this is not to be compared with what they suffer when the sun with its fullest force pours down upon them. Another advantage is they may be flooded with water in full sun, and evaporation under these conditions would be much more gradual. I have several times treated mine to a good soaking even in midday, and the ground has kept fairly moist for some time, and I am now being rewarded with good blooms. My original reasons for planting the Lilliums thus thickly was to give them a covering in the event of spring frosts, from which they suffer very much. Planted upon the same principle I have *auratum* in abundance, and that grand variety *platyphyllum*, also Tiger Lilies, *longiflorum* in variety, *elegans* in many forms, *davuricum*, the scarlet *Martagon*, with several of the varieties of *L. speciosum*. None of these have the slightest chance of shade overhead, and thus planted are in excellent health notwithstanding the great heat. From this I draw the conclusion that overhead shade is not absolutely necessary to success, provided the sun be not allowed to scorch the surface of the bed. Where thick planting cannot be indulged in a mulch of short litter or cocoa-nut fibre should be given, and deep planting always indulged in for all Lilies except it be the dwarfer forms of *elegans*.

For the sake of experiment I planted a few weeks back some fine bulbs of *L. candidum* against my cottage wall in a position where the sun pours forth all its fury from its rising till about 1.30 P.M. I have treated them liberally and planted them deeply; but I shall, all being well, cover the ground deeply with cocoa-nut fibre or short manure as soon as the flower stems are well up, and patiently watch the result, as compared with the large bed, which will receive no special treatment at that time. I trust those who have failed with their border Lilies this year will carefully weigh the experiences I have here advanced, for I have come to the conclusion that nearly all the family may be grown in full sun, provided the surface of the bed be supplied with a light mulching. The Swamp Lilies, we all know, delight in full sun, but the bed being always moist quite alters the condition of things; indeed, there are numbers of reputed shade-loving plants which, if planted in a boggy spot in full sun, succeed admirably, and especially does this apply to some of the lovely species of Himalayan Primulas.—A LILY GROWER.

#### HOLLYHOCKS.

"W. D.," in his able paper on the Hollyhock in your issue of the 10th inst., has set me thinking about the years and scenes of olden times, when the Hollyhock was grown and shown near perfection in spike and out flower at the Crystal Palace, Alnwick, Bishop Auckland, Brighton, and Edinburgh, and recalls the names of Chater, Paul, Bragg, Bircham, Laing (afterwards Downie, Laird, and Laing), Harrison, McIndoe, Oliver, the Rev., afterwards Lord Hawke, and Henry May. It is to the first-mentioned, the honoured name of Chater, as a nurseryman we owe the first great impulse given to the growth of this noble flower, by exhibiting throughout the United Kingdom a collection or selection of improved forms, raised by Chas. Barron, a shoemaker by trade, I believe. The raising of seedlings from them was afterwards taken up extensively by Chater, Paul, &c., and the flower made rapid strides. I well remember the day after the first National Rose Show, held in St. James's Hall, running down to see Mr. Chater at home for the first time as a stranger. After that day we were no longer such, and I cherish many pleasing recollections of him. From there most of the best flowers were being sent out. I had afterwards a look in at Cheshunt, and as many grand sorts came from that classic ground for the Rose, such sorts as *In Memoriam*, *Lizzie*, *Eldorado*, &c.; thence to London and Slough, with *Dahlia* Umpire on the brain, to see Mr. C. Turner. I called in at Bragg's to see a seedling Hollyhock *Primrose Queen*, and a right regal flower it was (no flower to be seen so full now) when well done. After a time other raisers and growers came to the front. Mr. Laing was then at Dysart House, and well do I recollect his *Beauty of Dysart*, so delicate and so beautiful in spike; his grand *Lord Loughborough*, so richly shining, so large and massive, for years often the corner peg—back row. To give those who are beginning to boast of Hollyhock growing some idea of the size of the flowers as grown, one of my men when going to Malton Show wagered the late Mr. G. Edward he had a flower 9 inches across. He won the wager with *Lord Loughborough*, but did not put the flower into the stand, and bear in mind this was not considered the *Anak* (Chater's) amongst Hollyhocks. The last-named stood first in Chater's list. Well do I also recollect my first essay at the Crystal Palace, being disqualified for showing on plain white eards,

a practice afterwards followed by all, an extra prize being conferred to mollify my irritated feelings. But when that true-hearted florist, Mr. Chas. Turner, then exhibiting, asked how such flowers were produced, it mattered little to me what minor lights thought.

Now we come to the time, about 1860, of the raisers of such flowers as Willingham Defiance, William Oats, &c. At the modest parsonage at Willingham, with its then rector, who had become enthusiastic in his love for his pets, they were grown and seeded in every corner. He was never tired of corresponding about them, and this must have been voluminous between Chater and him. Now comes the time when all the southern growers were defeated by Hawke; Downie, Laird & Laing; McIndoe, then at the Archbishop's. York and Bishop Auckland stand out pre-eminently as the finest shows of this flower in the kingdom. The very liberal prizes offered by that society for spikes and blooms. During the competition and in 1863 the writer of this grew and staged the flowers and spikes spoken of by "W. D.," which drew from my late friend, Lord Hawke, the remark, "I will beat you next year if it costs me £100." The next year came. Work triumphs sometimes over money, and it is recorded that it did so in this instance.

The Hollyhock at present. The disease has cleared out many of the grand old sorts. In looking at the seedlings certificated last year as shown, I could, and did wish, in the name given to one of them. Revival, it might be such, but I am afraid from my own experience during the last twelve years, immediately we begin to feed the plants the disease appears, and in a few days we have, in moist weather, a mass of corruption. Single or semi-double sorts I find resist the disease much more than the full sorts, and are hardier, so are the buff and pink. There is no doubt about the disease being very contagious. I lost my first here by purchasing seed to produce small plants to graft on. A fresh start was made again, from a firm who says, "They are clear." This, I doubt, and I feel anxious about such grand old sorts as Hercules (Chater's) which has no modern equal.—WILLIAM BOSTON, *Manor Farm Nurseries, Carthorpe, Bedale.*

ACCORDING to Mr. Dean's request I have much pleasure in sending a list of the few old varieties I possess. Old Cygnet, with me better than any of the new whites I have yet seen; Black Prince, beautiful colour and spike, but rather thin for exhibition; Decision, puce, shaded salmon, very fine; Purple Prince, grand spike; Memnon, crimson; Hercules, rosy salmon, fine spike; George Wilson, good crimson; and last, but not least, William Dean, peach colour, and certainly the best of the old varieties. Should we all hold to the good for another year I will be pleased to send Mr. Dean a box of blooms from any of these old favourites, if he likes to communicate with me about the middle of August. Perhaps it may also interest Mr. Dean to know the varieties I carried off the prizes with at our local show on Sept. 6th. They were as follows. For the best twelve blooms I staged Duchess, Mrs. Bruce, The Queen, Decision, Sultan, Mrs. Edwards, Lady Middleton, Cygnet, F. G. Dougal, William Dean, Mrs. Edgar, Mrs. Sharp. For the best six blooms I had Model, Mrs. Bruce, Jas. McDonald, Alba Superba, The Queen, Hercules.

Now perhaps I may be allowed to ask Mr. Dean for a list of what he considers the best twelve leading varieties at the present time. As a florist, his services will, no doubt, often be called upon as judge at different shows; he will therefore have been able to note a few of the best varieties. Such a list will be greatly appreciated by many amateurs like myself. It is through such notes that amateurs who have not the privilege of attending the principal shows are assisted in forming their collections. I hope, therefore, any other reader of the Journal interested in the Hollyhock will give us their experience. We have an election of Roses, Dahlias, Pansies, Carnations and Picotees, why not the Hollyhocks?—G. STEEL.

## ASPARAGUS CULTURE.

(Continued from page 193.)

**AUTUMN TREATMENT.**—When the haulm is decayed or leafless cut it off and burn it. Weeds should be cleared off about the plants and the soil lightly stirred, adding soil, if necessary, so as to cover the crown 3 to 4 inches. Over each crown a little partially decayed manure may be placed, and cap-like so as to throw off the wet. This, however, is not a necessity, but is good in clay soils in throwing off rain and snow. The mulching and weeds are to be turned under so as to improve the close surface, and on the open one the manure is placed when convenient. Avoid applying manure to a close surface, as a loose one has the benefit of rain, snow, air and frost, thereby securing the enriching and ameliorating influences by which food in the soil is assimilated.

**SPRING TREATMENT.**—This consists in taking the littery material

from over the crown, and seeing that the soil is fine and loose to a depth of about 3 inches. The remainder of the space is forked over and left rather rough, but not so rough as to expose the roots. The object is to let rain and air have a chance of entering the soil. In heavy soil it may be necessary to break the surface finer in April, but in light soil it is unnecessary. Avoid raking, which injures the Asparagus, however much it may please the eye.

**PREPARING FOR CUTTING.**—If bleached heads are wanted cover the stools to a depth of 8 or 9 inches with fine sandy soil, leaf soil, cocoa refuse, sand, or ashes early in April. The depth is inclusive of that over the crowns. This draws the heads up clear and white, and when the heads are peeping through, and have assumed the esteemed rosy purple or purple tips, the material is drawn aside, and the head broken off close to the crown. It snaps like a Carrot, therefore be careful to get a grip well down, or cut with a knife. These heads are esteemed by connoisseurs; but the epicure requires quality or flavour along with the blanching. To secure this the bleaching material must be applied a little at a time—*i.e.*, when the heads appear give an inch depth, and continue doing this until the heads have the required length—*viz.*, 6 to 8 inches. This gives the requisite purple tips, and the lower part is more tender and fully flavoured. It can only, of course, be practised to the full extent on the first heads, but the closer it is done the more likely are the heads to please. The bleaching material must be removed, when it is done with, gradually. This will be about the beginning of June, as Asparagus connoisseurs are equally fond of Peas, clearing it all away, leaving the crowns covered with 2 to 3 inches of soil.

The heads of Asparagus are liable to be injured or destroyed by frost. Flower pots with the hole stopped with hay are useful for inverting over them in case of frosty weather prevailing when the grass is coming up. They can be used at night and withdrawn by day. It insures full flavoured grass being had which otherwise is not attainable in frosty weather without employing glass and protection. I have found a little coarse hay or soft straw useful, having the material dry and handy for placing over the heads in case of sudden frost.

**CUTTING.**—In the fourth year of the seedlings and third of the planted roots the heads are fit to cut. They should not be less than 6 nor more than 8 inches in length. Remove a little soil around the base with the Asparagus knife, so as to admit of each head being cut without prejudice to other rising heads, or the least damage to the buds and crown. The hole should be closed again after cutting. The first heads are good, the second fine, and the third best of all; this in respect of their springing from the same crown or buds formed at the base of the respective haulm of the previous year. Two cuttings or at most three may be taken, and then we must make a reservation. It is the third week in May in an early season, the last in May or first in June in a late season. Let a good head then be allowed to grow, and get all that is wanted to remain within a fortnight—*viz.*, by early June in an early season, and by midsummer in a late season. All other must be cut, keeping to the reserve growths. No other must be allowed, unless a stronger shoot spring from the base of any of the reserved growths before midsummer, then cut the weaker away, and if a strong shoot spring from the base of any reserved shoot after June let both remain. The older growth may be cut away in favour of the more vigorous young growth, but it can do no great harm by remaining, and certainly will tend to maintain the activity of the roots.

But it may be urged that few can afford to make a reservation so early as the third week in May, or even late in that month or early June. Still cutting the finest heads, and making no reservation until the heads come weaker, is a sure road to exhaustion and inferiority of produce. It is one reason, too, why foreigners are able to supply the markets with earlier and finer produce. Under the best system at present all suitable "grass" is cut up to a certain time in June, generally ruled by the coming into use of Peas, and is the first to third week according to the season. It is not much later—ten days or a fortnight at most—than we advise, but there is a lot of difference in the time, inasmuch as all the best heads are cut, and the reservations are weaker. From this cause alone the Asparagus is often much weaker in the second than the first year of cutting. It not only weakens but it causes the Asparagus to come later for cutting. However, some will practise it so that I have only to say that the best shoots should be retained when the cutting ceases, leaving them sufficiently far apart that they will have space for development, keeping all weaker cut away as they appear.

**CUTTING EARLY.**—Cultivators of Asparagus are naturally anxious to cut as soon as possible after sowing or planting, but I find the vigour of the plants is in proportion to that of the roots. In the third year, if we are determined to cut and not follow the procedure advised in that year, the first heads are good, their cutting causes other to spring sooner and better, and its cutting gives a third, and this may be even finer than the second, due to the excitement given the roots by the spring of the heads and the more genial weather. The next head that appears is weaker. Let it grow by all means, but it will never make such fine buds nor give as fine "grass" afterwards as if the treatment had been that advised for the third year. By letting all the heads grow in the third year, and only displacing growths as succeeded by stronger we attain to a much stronger haulm, so that the encouraging of grass up to a certain point has a strengthening tendency, when by cutting it away the strong or succeeding growth is encouraged by the nutriment liberated and concentrated upon it.—G. ABBEY.

(To be continued.)



## SOME NEGLECTED PLANTS.

## MUTISIA DECURRENS.

A RARE hardy climber of simple and easy culture. Too often has this plant been killed by kindness or by keeping it in heated structures, for it is one of those plants that cannot and will not endure artificial heat or coddling. It delights in a deep moist peaty bed well drained; it is a lover of cooling shade, and it rejoices in being left alone and undisturbed. Several years ago such a plant was to be seen at the end of one of the Orchid houses in the Pine Apple Nursery, Maida Vale, where it attained to the height of 7 feet or more, its only support being some strings or wires to which the tendrils at the extremities of the leaves readily clung; radical growths were annually produced, and little or no care was bestowed upon it. In flower it is always sure to attract attention. It is not unlike a self-coloured *Gazania*, and possessing that delicious shade of clear apricot red to be found in very few plants, climbers especially, though it may be found in *Lilium elegans*, *Batemannia* and *venustum*. The flowers of this *Mutisia* are consequently very conspicuous, and it is a mystery why such plants fall into neglect. I saw the plant a year or two back at the Botanic Gardens, Cambridge. It occupied a partially shaded position at the southern end of the bog garden, rambling over some old tree stumps. When I saw it, if I remember rightly, it had not flowered, and was only recently planted. By giving it a little attention at flowering time seeds may be procured and a stock soon raised, which would be welcomed. Its other means of propagation is by the small young growths as they emerge from the base of the plant. These, if traced a little way, invariably have small root fibres attached to them, and should be potted in peaty soil and kept close till growth has commenced, taking care not to overwater. I may add that a spongy peat seems to suit it best, and certainly it is one of those plants which the searchers after rarities would do well to take in hand.

## ROGIERAS.

These we rarely see nowadays. They are plants of fairly easy culture, and very beautiful stove shrubs. They will also thrive well in an intermediate temperature. The great enemy of these plants is red spider, but by a constant and free use of the syringe it may be grown to perfection. A few plants, too, soon fill a house with their delicious fragrance, which is not overpowering, but mild, and pervades the atmosphere in an agreeable form. In one particular the *Rogiera* is like the *Ixora*—namely, in repaying the free use of the knife; in fact, hard pruning is, in my experience, essential to its free-flowering and general well-being, and cannot be indulged in too freely. This should be done when the plants have completed their flowering, withholding water for a time till the plants have started well into growth, keeping them syringed two or three times daily. If required, they should be potted at this stage, using loam and peat in equal quantities, and a fair proportion of sand and well-decayed stable manure to about one-fifth of the soil. The growth should be completed in a warm temperature, and should some three or four growths take the lead, as is usual in these plants, particularly with *R. cordata*, they should be pinched back to within three or four joints from the break, to insure a uniform growth. This completed they may be stood out of doors, after the manner of *Azaleas*, in a sunny spot, and so get the wood thoroughly ripened. The species above named is a vigorous grower, and in consequence pot room should be limited, by adopting which a great number of smaller growths will be forthcoming, and consequently smaller trusses of bloom, which may be taken as a still further advantage, as they are much more useful, and in a greater variety of ways. *R. gratissima* is smaller in all its parts, and produces exceedingly pretty trusses of bloom, which in bouquet arrangements have an almost unique appearance. This species is generally more compact than the first-named. I have never seen it grown in such quantity as it is in the nurseries of Messrs. Heath and Sons, Cheltenham, who appear to have a good idea of its value, and cultivate it accordingly. Both species are readily increased by cuttings made of half-ripe wood, and plunged in a good brisk heat as soon as rooted and the cutting pots have left the propagating frame. Attention should be given them at once, and as soon as fairly hardened they should be stopped, for they are in this respect similar to *Bouvardias*, and should never be allowed to become leggy, which they soon do if neglected in their early days. This species is more inclined to be bushy than the first, and it makes shorter-jointed wood. Brown scale sometimes attack both species, but not to the same injurious extent as red spider, which is best kept at bay with the syringe. Should it gain ground, however, it can be dispelled by using quassia chips and softsoap. Take a 48-potful of the chips (I name the size pot, which is more likely to be at hand than weights and scales) and 2½ gallons of soft water, boiling the same for a quarter of an hour, or if the chips have not sunk in

that time, boil a little longer, pour off the liquid, and add about 2 ozs. of the soap, and stir well together. When cooled down it will be ready for use.

## HOVEAS.

*Hovea Celsi* is a plant which from the intensity of its flowers and the rarity of its colour is deserving the attention of everyone who has a greenhouse and can command a temperature of about 40° in winter time. It is surprising how rarely one meets with this plant, and I am sure no one can see its lovely deep blue-purple flowers without admiring it. It flowers in the winter too. The plant is a native of New Holland, whence it came early in the present century. There are peculiarities about this plant. It is one of the slowest growing hardwooded plants. A straight clean stem is formed to nearly 2 feet long before it can be induced to form a bush, from which it may be inferred that it would make a good standard. According to my experience, however, seedlings are the more liable to this erect growth than cuttings. There is a little trouble with it afterwards, for it breaks and bushes naturally. Another peculiar point is in its flowering, in which respect it is more profuse, the flowers being produced throughout the length of the preceding year's growth from the axils of the leaves; and not only so, for flowers are again produced from the base of the old leaves. Though I have never tried it in such a position, I am inclined to the belief that it would make a good plant against a wall the same as *Camellias*. Plants destined for this purpose will be best grown as standards to 3 or 4 feet high, which may be accomplished without difficulty, after which tie out the branches to the wire trellis. It delights in sandy peat and old mortar rubbish, which must be pressed firmly about the roots. Seeds should be sown as soon as ripe in finely sifted peat and sand, and when above the soil should be grown on without a check.

Like most members of the order to which it belongs this *Hovea* seeds somewhat freely, but as it weakens the plants it should be thinned out at an early stage. The raising plants from seeds is a comparatively easy matter. Cuttings, however, are not so simple a matter, for these, even in the hands of a professional propagator of hardwooded plants, require both skill and patience. The seedlings should be grown on in sandy peat, at first finely sifted, but in the rough chopped state when they are strong enough for 6-inch pots, always potting firmly after the manner of New Holland plants generally. At no time does this plant require more than a greenhouse temperature, except perhaps in getting up the seedlings, which may be placed in an intermediate house, but given plenty of light and air as soon as the seedlings appear above the soil, and removing to a cooler house as the plants increase in size. Unless the plants are large enough for 4-inch pots by the end of July it will be as well to let them remain in the seed pans for the winter, keeping them in a temperature of from 40° to 50°, and pot them early in spring.—J. H. E.

PREPARING STRAWBERRIES FOR FORCING—  
CROWN SPLITTING.

I HAVE never tried the method described by Mr. Inglis, but intend to make preparation for doing so another year if circumstances allow me to carry it out. The main objection to the system appears to be "crown-splitting," but the system of preparing plants under review would not have been so forcibly advised if it had resulted in the majority of the plants "splitting" their crowns; I therefore regard the mild criticism as intended to elicit information. That such will be gladly welcomed I do not doubt, but if this is the sole objection that can be raised against Mr. Inglis's system it is scarcely worth attention. I pictured when I read the article objections of far more importance, which must certainly be considered in these days when the results have to be measured by the side of the outlay in production.

I have tried every system, Mr. Inglis's excepted, that has been advocated in the *Journal* for the past ten years or more, and have found none that entails less labour and time in preparation than layering the plants into the fruiting pots. In seasons like this various methods have to be adopted to raise the necessary stock of plants. This year we have had to depart widely from our usual system, and the methods adopted have more firmly convinced me of the necessity of having plants reserved purposely for the supply of runners, the ground being mulched early in the season, so that the plants do not suffer by drought.

The first objection, then, to Mr. Inglis's system is the lengthened period the plants are on hand compared with layering direct into the fruiting pots. There is some uncertainty that the young plants will safely pass a trying winter and spring. For my own part I should hesitate before relying solely upon the stock of plants so raised. I am aware that the Strawberry is very tenacious of life, and is not easily destroyed, yet the trying weather of last winter and spring told heavily upon our stock of young plants. They suffered severely in spite of being established in the ground before Mr. Inglis thinks of severing his from the parent and planting them finally for the winter. If we suppose that they pass the winter safely after the labour of making them firm

in the ground during the spring months they are checked sometimes before they are established in their large pots, however carefully the plants are lifted. If the plants were lifted with balls of roots, transferred elsewhere, and well watered, the risk would not be so great. If the soil is pressed firmly into the pots it is impossible to repot them without giving them a check; if potted loosely this might be more certainly accomplished. Firm potting is, however, of considerable importance—first, in order to place as much food as possible within a given space; secondly, to save labour in watering; and thirdly, to insure the plants making a sturdy growth. The condition of the plants in autumn depends in a very large measure upon the manner in which they have been potted or the pots filled before they were layered into them.

Strawberries cannot be lifted and potted with the same despatch as pots can be filled and the runners layered into them. A man would fill and empty pots and layer more than three times the number that he could lift and repot. When 4000 or 5000 plants are required this is a matter of some moment, and must be duly considered in any system of preparation, especially by those who have to pass the fruit into the hands of the wholesale fruiterer. Whether, however, this is the case, or the fruit required for private use, it is a matter of equal importance. By Mr. Inglis's system the plants are nearly a month longer in their large pots than is the case when layered into them, and this occasions considerable extra labour in watering. For some time after lifting and potting it is necessary to water them with great care until the plants overcome the check they have received and are rooting freely. With those layered into the fruiting pots a general system of sprinkling for the first month only is needed.

I cannot perceive how crown-splitting can be urged as an objection to the system advocated by Mr. Inglis. The plants are, in my opinion, no more liable to split their crowns than those raised by layering into the large pots, or any other method that is practised. Split crowns are due largely, not entirely, to the system of culture adopted. It may be asked, What is the cause of split crowns? and if I venture an answer it is to the effect that confining or restricting the energies of the plant into one channel causes the crowns to divide in the latter stages of growth. This will be especially noticeable if the autumn proves favourable for late growth and the plants have been grown strongly. Weak plants or those of moderate strength may with certainty be confined to one crown, but if they are strong and the crown developed as much as possible they are almost certain to split in the last stages of growth.

It is natural for the Strawberry to increase the number of its crowns, which the majority will commence doing after have reached a certain stage if they are growing luxuriantly. If early healthy runners are selected and grown on without a check, such varieties as Vicomtesse Hericart de Thury, Sir Joseph Paxton, and others are certain to increase the number of their crowns, and this cannot well be prevented; in fact, the only means of doing so is to treat the plants so that by the end of the season they are only of moderate strength. The crowns can be removed, and this system is often practised with strong plants, with the result that numbers of crowns "split." Some years ago I was determined to confine the whole stock of my plants to one crown each, and to accomplish this removed all crowns but the main one as they appeared. I was thoroughly well pleased with the result until near the conclusion of the season, when the majority divided their main crown. This result was anything but gratifying, and I determined that in future I would allow the plants to take a natural course, and the result has been all that could be desired. If this method is pursued, by whatever mode the plants are prepared, "crown-splitting" will be reduced to a minimum. If Mr. Inglis allows his plants to grow naturally after they are potted, I do not think he will be troubled to any serious extent on this head, but if he confines them to one crown a large percentage of the crowns may split if he attempts to grow them strongly.

When we plant outside we leave the plants to follow the course that is natural to them, and they fruit well and abundantly the first year. Under these circumstances I fail to observe why the crowns of those grown in pots should be tampered with and subjected to an artificial system of restriction. No advantage, in my opinion, is gained by having plants with one crown only. Two or even three well-matured crowns in each 6-inch pot are much better; from these more large fruits can be obtained than when the flower stems rise from one crown. Each strong flower spike will produce a given number of large fruits, and the remainder are of second size only, therefore the more strong flower spikes the greater the number of large fruits that can be taken from each pot. When the plants are left to nature, as far as the crowns are concerned each plant if strong (say of Sir Joseph Paxton) will have three crowns—the strong or main one, and one on each side of moderate strength, which are capable of producing one strong spike each.

I am not much impressed by the method detailed by Mr. Inglis, unless he recommends it as one upon which to rely in an emergency, such as has occurred in many a garden this year; and under these circumstances it is well worthy of consideration.—WM. BARDNEY.

## VIOLAS.

MR. DEAN asks in the course of his interesting remarks at page 245 why I have omitted "True Blue" from my list, and I answer by an unintentional oversight on my part. It is all that Mr. Dean says of it, for there is nothing near it in point of colour, while for a compact grower and free-flowering variety it is unequalled in the group. I am growing a quantity of it this time, for it is so beautifully adapted as an edging to the silver-leaved Pelargoniums, and the two harmonise

beautifully. It is exceptionally dwarf, and in this respect may be compared to *Lobelia* Emperor William, and I consider it the best blue extant. *Apròpos* of Skylark, I may state that the margin of blue has returned to it in several of the flowers since the cooler nights have come, for it is strangely interesting that heat should have such an effect on any flower; and it would be still more interesting to learn whether this pleasing characteristic would be constant in colder climes than our own. I will plant a few in a north aspect and note the results.—E. JENKINS.

## THE EDINBURGH APPLE AND PEAR CONGRESS.

THE official report of the Apple and Pear Congress held at Edinburgh, November 25th to 28th, 1885, by the Royal Caledonian Horticultural Society has just been issued (Edinburgh: MacLachlan and Stewart), forming a valuable embodiment of facts relating to the varieties suitable for different districts in Great Britain. It is edited by Mr. Malcolm Dunn, gardener to the Duke of Buccleuch, Dalkeith Park, to whom much credit is due for the admirable manner in which the information furnished by the various exhibitors has been tabulated and arranged. It is stated that 12,730 samples were examined by the jurors, and that amongst them upwards of 5000 were named or corrected. From Scotland 8000 samples were shown, 1000 being Pears; 4000 came from England and 560 from Ireland, together with some from Nova Scotia and elsewhere, of which a descriptive list is given at the end of the report.

As an example of the style adopted in the work we extract Mr. Dunn's report from the Midlothian portion:—

Mr. Malcolm Dunn, The Gardens, Dalkeith Palace, Dalkeith. Number of varieties exhibited, 270 Apples, 80 Pears = 350.

Altitude, 190 feet; aspect, south by east; site, sheltered; soil, light loam; subsoil, open gravel.

*Observations.*—A fine collection of Apples and Pears, embracing good specimens of the best varieties, among which are notable samples of the following Apples:—Alfriston, Cox's Orange Pippin (very good), Ecklinville, Warner's King, The Queen, Blenheim Pippin (extra fine), Calville Rouge d'Automne, Court of Wick, Cox's Pomona, Lord Derby, Lord Suffolk, Golden Spire (extra fine), Green Leadiugton, Wellington, Fullwood, Hawthornden, Kentish Fillbasket, Golden Nohle (very fine), Gravenstein, Mère de Ménage, Dutch Codlin, and King of the Pippins.

An interesting collection of sixty varieties of Apples, grown on dwarf bush trees, two years planted, gives a useful practical illustration of the productive and early-bearing qualities of the Paradise stock, the fruit being of fine size, clear, and well coloured. In addition to many of the varieties already named, this collection contains fine specimens of Worcester Pearmain, Loddington, Lane's Prince Albert, Galloway Pippin, Peasgood's Nonesuch, Striped Beaufin, Bauman's Red Reinette, Ribston Pippin, Golden Pippin, Duke of Devonshire, Maltster, Lady Henniker, Claygate Pearmain, Potts' Seedling, and Ribston Pearmain.

Among the finest Pears are Marie Louise, Beurré Bosc, Beurré Diel, Beurré d'Amanlis, Hacon's Incomparable, Williams' Bon Chrétien, Louise Bonne of Jersey, Winter Nelis, Beurré Rance, Glou Morceau, Comte de Lamy, Catillac, Thompson's, Gansel's Bergamot, Easter Beurré, and Swan's Egg.

*Exhibitor's Remarks.*—Apples.—There are about 700 Apple trees of various descriptions, in a bearing state, in the gardens here. A few standard trees of Hawthornden, Paradise Pippin, Winter Strawberry, Oslin, Thorle, Cockpit, &c., are over a hundred years of age, but are still vigorous and bear freely. About 100 trees, mostly standards, are from sixty to eighty years of age, in fine bearing condition, and comprise most of the best Apples cultivated in the early part of this century, including Alfriston, Blenheim Pippin, Brabant Bellefleur, Ecklinville, Keswick Codlin, King of the Pippins, Gravenstein, Manks Codlin, Royal Codlin, R. d. Calville, Wellington, Yorkshire Greening, and "Macdonald's Apple," a seedling Apple raised here about seventy years ago, and now known as "Yorkshire Beauty," with several synonyms. About 350 trees were planted between 1835 and 1845, during the time the new garden was being formed, the greater part of which are dwarf or bush trees. The remainder have been planted within the last thirty years, and include all the best of the newer varieties.

Among those recently introduced, the following are the most promising, and a few of them will probably displace some of the older "best varieties" in their season—viz., Lane's Prince Albert, Worcester Pearmain, Annie Elizabeth, Peasgood's Nonesuch, Loddington, Potts' Seedling, Golden Spire, Northern Dumpling, Lady Henniker, Lord Derby, Grenadier, Domino, Sandringham, Bramley's Seedling, Ringer, Red Reinette, Frogmore Prolific, and Schoolmaster.

Fully more than half the total number are dwarf "bush" trees from 4 to 7 feet high, about 100 are pyramids, and the remainder are standards. About 200 are on the Paradise stock, and the others on the Cab and Free stocks, these being the most durable in our light soil, where the Paradise fails to be productive after a few years of abundant bearing. The soil is a light loam, with an open, gravelly subsoil, not naturally well adapted for fruit-growing, but under heavy and regular manuring it produces abundantly. If manure is withheld, even for a season, the crops fall off at once, both in quality and quantity. Mulching is highly beneficial to all fruit trees. Standard trees receive a moderate pruning every winter. Pyramids, bushes, and wall trees are regularly "pinched" in the summer, and require very little winter pruning. Seldom do any trees require root-pruning. If too luxuriant, the roots are merely lifted and carefully laid in again near the surface, which is generally an effective remedy. The fruit is thinned when too numerous on wall trees, pyramids, and bushes.

*Pears.*—These number about 300 trees of all descriptions in bearing, and are of the same ages as the Apples, the oldest being Warden, Jargonelle, Muirfowl's Egg, Autumn Bergamot, Catillac, Achan, Hesse, and Swan's Egg. About one-third of them are trained on walls; a third grown as bushes and pyramids, and the remaining third as standards. The greater portion of them are on the Free stock. These on the Quince bear freely for a few years, but soon wear out and require to be renewed. All receive the

same treatment—manuring, pinching, pruning, training, &c.—as given to the Apples, and in ordinary seasons are equally productive.

The varieties named in the selected lists are what are found to be the best here. In Classes I., II., and III., the variety named for each month is the best, fit for use, in that month.

The analytical lists of varieties for England, Scotland and Ireland are very useful, and the following summary of varieties for the whole of Britain is especially interesting:—

#### BRITISH APPLES AND PEARS.

In the order of the total number of votes which each variety received in each class, as the best for cultivation in the United Kingdom.

Number of selectors, 118.

**Class I. Thirty Dessert Apples.**—King of the Belgians (95), Blenheim Pippin (85), Ribston Pippin (82), Cox's Orange Pippin (76), Kerry Pippin (72), Irish Peach (69), Court of Wick (44), Duke of Devonshire (32), Thorpe Pippin (31), Worcester Pearmain (28), Devonshire Quarrenden (25), Sturmer Pippin (25), Court Pendu Plat (23), Oslin (22), Claygate Pearmain (20), Golden Pippin (19), Gravenstein (17), Red Astrachan (17), Red Juneating (17), Scarlet Nonpareil (15), Cambusnethan Pippin (14), Early Harvest (12), Cornish Gilliflower (11), Margil (11), Rinet du Canada (11), Paradise Pippin (10), Wyke Pippin (10), Golden Reinette (9), Cackle Pippin (8), Lemon Pippin (8).

**Class II. Thirty Culinary Apples.**—Lord Suffield (94), Ecklinville (89), Alfriston (87), Wellington (86), Keswick Codlin (85), Stirling Castle (83), Warner's King (82), Hawthornden (49), Northern Greening (45), Blenheim Pippin (43), Tower of Glamis (36), Yorkshire Greening (35), Golden Noble (27), Cellini (24), New Hawthornden (17), Gloria Mundi (15), Manks Codlin (15), Norfolk Beefing (15), Cox's Pomona (14), Bedfordshire Foundling (13), Kentish Filbasket (13), Emperor Alexander (12), Mère de Ménage (12), Potts' Seedling (12), Gravenstein (10), Hambledon Deux Ans (9), Prince Albert Lane's (9), Reinette du Canada (9), Striped Beefing (9), Yorkshire Beauty (9).

**Class III. Thirty Dessert Pears.**—Jargonnelle (88), Marie Louise (88), Easter Beurré (75), Williams' Bon Chrétien (70), Louise Bonne of Jersey (65), Glou Morceau (53), Beurré d'Amanlis (51), Beurré Rance (45), Winter Nelis (43), Hacon's Incomparable (42), Josephine de Malines (34), Bergamotte d'Esperen (30), Beurré Diel (28), Beurré d'Arenberg (23), Doyenné du Comice (19), Doyenné d'Été (17), Napoleon (17), Nec Plus Meuris (17), Citron des Carmes (15), Monarch, Knight's (15), Beurré Superfin (14), Beurré Bosc (11), Muirfowl's Egg (11), Fondante d'Automne (9), Beurré Hardy (8), Pitmaston Duchess (8), Olivier des Serres (8), Thompson's (8), Beurré Giffard (7), Hesse (7).

**Class IV. Thirty Dessert Apples for Bushes &c.**—King of the Pippins (91), Kerry Pippin (78), Cox's Orange Pippin (77), Irish Peach (67), Blenheim Pippin (58), Worcester Pearmain (53), Court of Wick (49), Ribston Pippin (48), Thorpe Pippin (40), Devonshire Quarrenden (38), Golden Pippin (33), Oslin (33), Court Pendu Plat (30), Margil (30), Yellow Ingestrie (28), Cellini (26), Adams' Pearmain (25), Cambusnethan Pippin (25), Duchess of Oldenburgh (23), Duke of Devonshire (22), Golden Reinette (19), Gravenstein (19), Claygate Pearmain (17), Early Harvest (17), Sturmer Pippin (17), Golden Noble (16), Cackle Pippin (14), Lemon Pippin (14), Red Astrachan (14), Scarlet Nonpareil (14).

**Class V. Thirty Apples for Orchards.**—Wellington (83), Ecklinville (82), Warner's King (80), Stirling Castle (78), Keswick Codlin (75), Lord Suffield (74), Alfriston (71), Blenheim Pippin (65), Hawthornden (45), Golden Noble (44), Tower of Glamis (44), New Hawthornden (39), Yorkshire Greening (33), King of the Pippins (31), Cellini (30), Northern Greening (23), Manks Codlin (22), Duchess of Oldenburgh (20), Emperor Alexander (17), Bedfordshire Foundling (15), Beauty of Kent (14), Kentish Filbasket (13), Worcester Pearmain (13), Cambusnethan Pippin (12), Gravenstein (12), Prince Albert Lane's (12), Cox's Pomona (11), Hanwell Souring (11), Mère de Ménage (11), Potts' Seedling (11).

**Class VI. Thirty Dessert Pears for Bushes, &c.**—Louise Bonne of Jersey (66), Williams' Bon Chrétien (66), Beurré d'Amanlis (57), Marie Louise (44), Beurré Diel (42), Jargonelle (38), Hacon's Incomparable (35), Beurré d'Arenberg (30), Easter Beurré (30), Beurré Superfin (28), Doyenné du Comice (25), Swan's Egg (25), Beurré Bosc (23), Muirfowl's Egg (23), Beurré de Capiaumont (20), Autumn Bergamot (19), Beurré Hardy (18), Hesse (18), Pitmaston Duchess (18), Thompson's (17), Winter Nelis (17), Glou Morceau (16), Comte de Lamy (15), Doyenné d'Été (15), Flemish Beauty (15), Seckle (15), Citron des Carmes (13), Josephine de Malines (12), Monarch, Knight's (11), Napoleon (11).

**Class VII. Twenty Pears for Orchards.**—Hesse (72), Williams' Bon Chrétien (43), Louise Bonne of Jersey (41), Swan's Egg (29), Muirfowl's Egg (28), Beurré d'Amanlis (23), Hacon's Incomparable (21), Autumn Bergamot (20), Crawford (20), Black Achan (15), Aston Town (13), Beurré de Capiaumont (12), Jargonelle (12), Doyenné d'Été (11), Fertility (11), Marie Louise (11), Beurré Diel (10), Windsor (9), Croft Castle (9), Dunmore (8).

**Class VIII. Ten Stewing Pears.**—Catalac (84), Uvedale's St. Germain (43), Veulam (41), Vicar of Winkfield (21), Bellissime d'Hiver (17), Black Worcester (11), Gilgil (11), Cilebase Grosse (6), Belmont (5), St. Lawrence (4).

#### NOTES ON THE CULTIVATION OF ASPARAGUS.

WHILE reading the excellent remarks by "P. T. D.," September 15th, on the above subject, I thought I should like to know the reason why his Asparagus did not grow so well on the flat as in beds, more especially as I find many gardeners are growing Aspara us on the flat in preference to the beds, and are still advocating that system of cultivation as the best on light sandy soils such as "P. T. D." says his soil is. Perhaps the soil on the flat had not the liberal preparation before planting as the beds, also after being planted. I have long since discarded the autumn dressing of manure and put it on in spring some time in February, as I had an idea the winter rains washed the best of the manure into the subsoil and drains where the soil was light, and if the soil is heavy the manure makes the soil wet and sad. Now we leave

the beds till February, we then fork 4 or 5 inches of the soil into the alleys, and put on a good dressing of decayed manure. We then throw a little of the soil from the alleys on to the manure, and it is left light and free for the heads to come through. Early in April we give a good dressing of salt, and the spring and summer rains wash the goodness into the soil when the roots are active. My opinion is they require more nourishment after the cutting is finished than before, the quality of the Asparagus depending more on the previous summer's growth than on what they receive in the spring.

I quite agree with "P. T. D." in not having the beds more than 6 inches high, although I cannot see much difference at that height from the flat. In my young days we used to apply manure in the autumn by putting it on the beds without taking any soil off first. We then dug out our alleys from 18 to 20 inches deep, putting the soil on the manure. Such a thickness of soil caused the Asparagus to be very late in coming through.

I hope "P. T. D." will not think I want him to give up his mode of cultivating for mine. If he has succeeded so well I should say, Go on still, for nothing succeeds like success.—J. L. B.



**GRAFTING PEARS ON APPLES.**—We have received from Mr. Samuel Stevens, F.L.S., of Loanda, Upper Norwood, specimens of a Pear from a tree which was grafted accidentally on an Apple ten years ago. The Apple is Lord Suffield and the Pear Paradise d'Automne. The union between the scion and the stock Mr. Stevens assures us is perfect; and we can testify to the specimens of both kinds of fruit being perfect in development and excellent in flavour. Such an example of Apples and Pears growing on the same tree we have never known before, and the sceptical may probably smile at the announcement. We have in years gone by tried many experiments in the way of inter-grafting, but never succeeded in obtaining a union between the Apple and the Pear which lasted longer than two or three years, the Pear scion having always died or been blown off by the wind. The experiment of grafting the Pear on the Hawthorn has been often made and made successfully, some varieties thriving even better on the Hawthorn, in some instances, than on the Quince or the Pear stock; but such an instance as the present is quite new to us.

— "UTILITARIAN" asks—"What VARIETIES OF POTATOES are best to grow alike for the supply of a large private establishment and surplus for market, the supply having to be maintained throughout the year? Are there any better for a strong loam over clay than Veitch's Ashleaf for frames and early outdoor supplies, Beauty of Hebron, and Magnum Bonum? The object is only to grow three sorts—viz., early, second early, main crop and late, and to get as much quality as it is possible to combine with quantity."

— APPLES COLOURING.—In a letter "W. I." remarks:—"In the neighbourhood of Frome Apples are colouring much more brightly than usual. The hot dry season may have something to do with this, but the colouring has been most marked since the dull rainy weather has set in. Devonshire Quarrenden with us has been most beautiful, and of a brighter colour than I have seen it before. Irish Peach and Beauty of Bath were also very prettily coloured. Duchess of Oldenburgh, Cox's Orange Pippin, King of the Pippins, Blenheim Pippin, Adams' Pearmain, and Margil are all colouring grandly, and even such culinary sorts as Hawthornden, Lemon Pippin, and Winter Greening are colouring rapidly. All the fruit left after the recent gales promise to be of excellent quality, and I have no doubt will keep well."

— "F." contributes the two following notes—"The remarks on page 227 concerning the autumn flowering qualities of Madame Gabriel Luizet Rose called my attention to several large standards of the old favourite TEA ROSE HOMÈRE. Amidst a fairly representative collection of Roses this stands unrivalled, each standard, a few days since, yielding several scores of beautifully tinted firm flowers. This Rose is very hardy, being apparently quite indifferent to such a trifle as a sheltered situation. The standards alluded to are growing in a very exposed situation, but are far more robust than any other Rose growing near them. Writing in praise of such a general favourite as Homère may appear to many to be synonymous with 'carrying coals



to Newcastle,' yet there may be some who will remember the hint when the planting season arrives."

— "THE proximity of the bulb-planting season also calls to mind a rare feast I enjoyed last winter. I came unexpectedly upon a narrow border planted with the WINTER ACONITE, ERANTHIS HYEMALIS. The border was situated at the north side of a wooden trellis fence which was covered with Ivy, and the contrast between the bright yellow of the Aconites and the dark green foliage of the Ivy was very striking indeed, and was all the more pleasing, perhaps, on account of the vividness of the yellow being toned down by the dark gloom pervading the base of such a fence on a winter's afternoon."

— MR. R. GILBERT, Burghley Gardens, writes:—"At page 260, your correspondent, 'J. H. E.' has well said that the princely stove plant, GLORIOSA SUPERBA is neglected. At this moment I possess a beautiful specimen, worthily occupying an 11-inch pot. We have it plunged in a bed of sawdust about half way up. We train the shoot to the rafters of our little stove. It is just now, Sept. 22nd, in flower and is greatly admired. At one end of the stove we have a fine specimen of Allamanda Hendersoni in full bloom. I also possess a grand plant of that good old Orchid Dendrobium nobile, which an Orchid grower told me was a fac-simile of the one sent up from Chatsworth at the Orchid Conference. This I look upon as an achievement by a Cabbage grower."

— GLOIRE DE DIJON ROSE AND "E. M.'S" ANALYSIS.—Mr. W. J. Murphy observes:—"Growers of Roses must feel indebted to 'E. M., *Berk. hamsted*,' for the trouble taken in analysing the Roses at the National Society's Metropolitan Exhibition, and tabulating the result annually but is it not singular to find the name of this superb Rose wholly absent? Surely there are Tea, Noisette, and Bourbons in the first two dozen given that will never have the name, fame, or popularity of Gloire de Dijon? 'E. M.' concludes with 'a select list of various kinds that he can recommend for general cultivation, and for those who are not exhibitors;' and here again 'Old Glorie' is conspicuous for its absence. I have a bunch of blooms collected from the open border this morning before me as I write, and sweetly scenting all around, so did I not utter this protest against having it absent from any list of choice Roses for general cultivation under any circumstances I should consider myself very ungrateful, and am satisfied thousands will say so."

— A HERTS gardener writes—"We have the low, 3 feet, walls of our conservatory covered with TEA-SCENTED ROSES. They do well on their own roots. Those worked are planted so that the junction of stock and scion is 4 inches below the surface. As the conservatory is in the form of a cross, the ends being hexagon, we have every aspect. Those on the south are first to flower, followed in order by those on the south-east and south-west, then come those on the north-east and north-west, the north being latest, and, what I particularly wish to note, those on the north give by far the finest blooms. They are larger, have more substance, are deeper or more delicate, as the case may be, in colour, last much longer, and our ladies say sweeter. The blooms of Niphetos on the north aspect vie in size and substance with Magnolia blooms. The dwarfier growing varieties only are used. We are so pleased with them that we are about to clear a north wall of Currants, &c., and as it is 12 feet high shall plant the more vigorous or climbing Teas. The principle on which they are grown is the cutting out of the old and weak wood annually, encouraging young and vigorous from the base in its place."

— PRIMULA SINENSIS PLANTED OUTSIDE.—"Last year," says "T. F. B." "I saved a quantity of seed of the above-named plant. Being anxious to see if the seed was good, I sowed two or three pinches of seed the last week in July, 1886. The sowing produced many dozens of plants. They were pricked off about twice from the seed pan last autumn. The last time they were moved I placed the largest in 2-inch pots, the rest were planted in boxes. The latter made much the best plants. They were wintered in a cool vinery. Those in the boxes were potted at the beginning of March. They all remained in vinerics till the first week in May, when they were placed in a cold frame. I found there were more than could be looked after well in pots, so placed four dozen of those that had been in pots all winter in a sheltered place outside at the end of May. The last week in June they were planted

out. Having been in small pots all winter they were very poor when planted, and scarcely worth retaining for any purpose. If they had been good plants to start with, and in good soil, they would have made plants six times the size of those in pots. I am going to lift and pot them this week. I think the planting-out method a good one where great numbers of plants are required for decorating purposes and there is not much time to look after them in pots through the summer. I am forwarding three plants for your inspection." The specimens sent were extraordinarily luxuriant, the leafstalks 9 inches long and very stout, the blade 5½ inches by 6 inches. One of the plants had thirty great leaves, and when tied together the plant looked like a huge Cos Lettuce.

— TUBEROUS BEGONIAS AT YEOVIL.—"W." writes, "Mr. B. R. Davis, the Yeovil Nurseries, has long made this popular class of plants a specialty, and has every reason to be satisfied with the progress made. Many thousands of plants are annually raised, some being flowered in pots and still more in the open ground. In addition to his own seedlings most of the continental and English raised novelties are added to the collection. Among the latter the most noteworthy of the doubles are Ella L. Davis, a fine very double white; R. Steiger, bright rich scarlet; Phantasy, pink, shaded white; Cactus, lavender red; Centre of Attraction, Hollyhock shape; Julia Reimer, rosy red, very double; Postboy, salmon red, white centre, very striking; Wonderful, crimson red, very fine; Ball of Fire, brilliant scarlet; superba, dark rosy red, very double; Pink Perfection, fine; Volante alba, extra good white; Mauvette, mauve, purple shade, extra large; Crown Prince, salmon red; Mr. C. Tite, red, very pretty; Gaiety, true scarlet, one of the best; Lucina, salmon, white centre; Gem of Purity, good white; and Severn King, true salmon, cream centre. Single varieties of Mr. Davis's raising are also of great merit, notably Beauty, crimson scarlet; Glory of Yeovil, white; Rosy Emblem, bright rose; British Soldier, scarlet; Dolly Varden, pink shaded rose, extra fine; Alpha, magenta scarlet; Lord Derby, pink shaded rose; Star of Erin, magenta, shaded crimson, extra good; Kermesina, soft shaded scarlet, large and good. We also noticed several very fine unnamed sorts, and both these and all the foregoing are of good habit and free flowering."

— AT the recent ordinary weekly meeting of the WAKEFIELD PAXTON SOCIETY, held at Councillor Lupton's, the "Saw Hotel," Ald. W. H. Lee, J.P., the President, was in the chair, and Mr. Thomas Senior, solicitor, the ex-President, filled the vice-chair. There was a fair attendance of members. Mr. Henry Hazell of Ossett, until recently under gardener to Miss E. G. Mackie of St. John's, was elected a member of the Society. Mr. Ireland, head gardener to Baron St. Oswald of Nostell Priory, who devotes special attention to the cultivation of rare and beautiful Orchids, read his third essay on that subject before the members of the Society. Mr. Ireland dealt in an able manner with the cultivation of exotic kinds, enumerating the best species, and giving some valuable practical information as to the soil, the temperature, and other essential conditions necessary to the production of good flowers. An interesting discussion followed, and the ready answers which the essayist gave to a number of questions showed how thoroughly acquainted he is with the subject of which he treated. On the motion of Mr. Senior, seconded by Mr. T. R. Preston, and supported by Mr. Garnett, a hearty vote of thanks was accorded Mr. Ireland for his valuable essay.

— WE learn, says *Nature*, that the Government of Jamaica offers a premium of £100 for the production of the best practical elementary text-book of TROPICAL AGRICULTURE specially applicable to Jamaica and embodying the first principles of agriculture. It is stated that the object of the manual is to create in the mind of the young an early and intelligent interest in the soil and its products, and particular attention is to be paid to simplicity, brevity, and freedom, as far as possible, from technical terms. It is stated that the propagation and cultivation of tropical economic plants should have due prominence. Manuscripts are to be forwarded to the Government of Jamaica on or before August 1st, 1888.

— CUCUMBERS IN AMERICA.—At Fredericksburg, Virginia, a pickle factory has been started, and one of the specialties produced by it is pickled Cucumbers. The Cucumbers are grown on the poor and worn-out lands of that section, and the ground must be heavily manured. The cultivation of these vegetables appears to be a trivial affair, but has grown to be an important industry. The *Richmond Whig* gives the fol-

lowing important particulars of it:—This season the supply has reached 30,000,000 Cucumbers, those engaged in their production furnishing from 200,000 to 1,000,000 each. An acre will produce 100,000, and they sell at Fredericksburg at 50 cents per 1000. The object is to get them 1 to 1½ inch long, and this requires active picking before they increase this size. A boy can pick 3000 in a day. Picking them thus early increases the productiveness of the plants, and while the season lasts others are appearing in place of those taken from the plants.

—“THOSE who have not grown BELLADONNA LILIES well or seen them flowering abundantly cannot imagine,” writes “E. M.,” “what charming hardy bulbs they are. The colour is beautiful, the veins and markings are distinct—a soft peach colour on a white ground—and the delicate fragrance is exceedingly refreshing. The plants carry as many as ten blooms on each spike; the flowers also last a long time in perfection either upon the plant or in a cut state. The great point in its successful cultivation is choosing a suitable position, preparing it, and planting the bulbs, draining the soil carefully that no stagnant moisture lies about the bulbs during the winter months. No position suits them better than at the foot of a hothouse wall facing south. Take out the ordinary soil 1 foot 6 inches deep, place at the bottom 6 inches thick of clinkers or broken bricks, over this some rough turf to keep the drainage intact, filling with a compost of turfy loam peat, leaf soil, and some charcoal, about two parts of the former to one of the latter. Cover the bulbs about 2 inches deep with the compost. During the growing season apply water freely, afterwards withhold the supply. The beginning of February is good time to plant.”

## LONDON'S LESSER OPEN SPACES—THEIR TREES AND PLANTS.

NEW SERIES.—No. 4.

CHELSEA, like courtly Kensington, is a spot that might boast itself of its many associations in the past with Royal and distinguished personages, and even more than Kensington it merits a high place in the annals of floriculture. This pleasant village, for such Chelsea was no longer ago than some of its old inhabitants can remember, displayed in the grounds of several of its ancient mansions not a few of those early exotics which noblemen received from travelling friends, long before the culture of plants became a profession, and when nurserymen appeared upon the scene a cluster of them settled in this western suburb, so much visited by Londoners of all grades. Hence, along the King's Road, and nearly within view of Ranelagh House, once famous for its gardens, greenhouses, and greeneries, there was something like a dozen nursery gardens at the commencement of this century. Behind several of these were orchards, relics of which we find in scattered Pear and Plum trees, generally lying behind houses, and often leafless, as well as barren of fruit. It must be owned that the locality was not unsuited for the exercise of the gardener's skill, since it has a mild air, and abundance of soft water was obtainable from the Thames and other sources. But Chelsea became too attractive as a place of residence, and nursery after nursery had to vanish to give the builder free scope for his operations.

Comparing Chelsea with some other London localities, I judge that its soil and atmosphere are not favourable for the growth of trees to any remarkable size, excepting certain species to which moisture and warmth are congenial; still, it had at one time many goodly trees shading its parks and meadows which have now been felled. Yet, looking around its public roads and its byeways, we perceive that even yet Chelsea retains somewhat of its rural aspect; from the parks adjacent thereto various birds beside the cockney sparrow come into its gardens, and butterflies are common about its streets, usually the familiar whites, with an occasional tortoiseshell. Vines are numerous in Chelsea; we may see them not only trained on the walls of dwelling houses, as was formerly a favourite fashion in these suburbs, but also on walls; but I suspect now they seldom ripen the Grapes they produce. Pretty gardens yet remain, having arbours adorned with Clematis and Jessamine, and the perfume of their flowers is perceptible even on the smoke-laden air. Still, through accident or carelessness, or worse, Chelsea has not fared well in the matter of open spaces; these have been taken nearly all away, though some might surely have been preserved for the benefit of the inhabitants. First, Chelsea lost its common, a fine stretch of land, hill, and dale, well covered with vegetation, and almost joining the open ground on its north, which was once called Brompton Heath. Its “Five Fields” on the east, where choice vegetables were cultivated during Georgian days, are now the site of Belgravia, and other fields or meads near the Thames afterwards occupied by wharves and factories.

Then the Pavilion, with its grounds laid out by Capability Brown, after undergoing encroachments, disappeared entirely, but a few of its younger trees, chiefly Planes, are in the garden of Cadogan Square. Cremorne Gardens, which might have been retained as a recreation ground, went through the same process, and lastly Chelsea Park, which

had some of the finest Elms, Limes, and Poplars to be seen within or near the metropolis, once the deer park of Beaufort House, and an experimental silkworm nursery in Stuart times. But if Chelsea has lost a great deal, it has gained something, at least, in its Embankment, and this plot of land, partly rescued from the Thames, is already one of the most promising public gardens laid out for Londoners. It is overlooked on the land side by the quaint and irregular mansions of Cheyne Walk, the presumed “Dutch aspect” of which has somewhat suffered by recent alterations. Of the original Elms so often depicted in pictures as skirting the river's bank, and that were planted in the seventeenth century, or earlier, none remain, but yet there are descendants from these of a later generation, now become venerable, and some old Limes, also one conspicuously lofty Plane, which looks as if it was possessed of good vitality. Unfortunately, however, by the construction of this embankment several handsome Planes were destroyed. A very large but leafless Elm is carefully preserved in one of the gardens of Beaufort Row; it is interesting also because a Virginian Creeper planted beside it has covered the trunk from base to top with its festoons. Along the embankment during the last twenty years a variety of trees and shrubs have been introduced, but no particular display of summer flowers is made. The trees are put at such intervals as not to impede each other's growth. This point is not always attended to by the planters of public gardens. Here are Hawthorns scattered about, and this does well grown as a tree, only caterpillars infest it persistently, but they do little harm to the new varieties of Crataegus, which might be more freely planted about London spaces where there is plenty of air as on this embankment. It is observable that the Wych or Scotch Elm, of which there are some here, is well suited to a town atmosphere. The Birch, sometimes neglected by gardeners, thrives too, seldom failing to produce catkins even in a smoky air, and from the lightness of the foliage Birches do little harm to plants growing beneath.

About Chelsea Church, in the olden time, there grew some broad-leaved Willows, which have long since succumbed to insects; recently there have been planted more Willows, chiefly of the narrow-leaved varieties, which the soil suits well. Some of the old Poplars still survive, and others have been set to keep them company, the White and the Lombardy varieties being general favourites and of quick growth. Upon these Poplars occurs the singularly mottled, shaggy caterpillar of the moth called the Poplar Grey (*Aeronyeta megacephala*), which, when it is not feeding, rests on the leaves in “a doubled position.” Flitting about in the gleams of September sunshine, with its odd movement, is the vapourer moth, which has been also reared probably on the Poplar, or on some Hawthorn bush close by. A few Ash trees of the weeping kind remind us that this group of trees is less eligible for garden adornment than many, since other plants will not grow well beneath. Instead of this, as having a similarity of foliage, the Robinia may be planted. Chelsea has some finely spreading examples of this tree in its private gardens, but it rarely puts forth flowers. On the river embankments some evergreens do not succeed owing to the exposure; here at Chelsea Hollies flourish of several varieties, also Thujas, Cupressus Lawsoniana, and the large-leaved Privet, but Aucubas and Laurels seemed rather sickly. Of Ribes aureum and sanguineum some planted ten years since have made remarkable progress, and examples of the White Broom. Such hardy perennials as species of Dianthus, Dahlias, Chrysanthemums, and the inevitable Flag that must be in every London garden, with some ornamental grasses fill up the beds. Ferns have been left out, though a bank of them would be desirable.

An open space made free to the public this year is the churchyard attached to Chelsea parish church, now to be styled St. Luke's Gardens, and, singular to say, before it was a burial place this ground was a plantation belonging to one of the nurserymen of the King's Road, so it is again in the hands of gardeners, but devoted to flowers and shrubs, not trees. It has trees, however, for the lines of Limes and Elms exist which were planted on the four sides of the enclosure many years ago; some have died off, and the remainder have not improved under the treatment received from Chelsea urchins. The transformation was not an easy process, owing to the many tombstones, and rows of these have been arranged in a manner rather ludicrous, but it is intended to hide them partially from view by trelliswork covered with Ivy and more ornamental creepers. I observed the circumstance often noted, but not explained, that on some ground being turned over which had not been touched with the spade for years, several wild plants appeared which do not occur now about the locality. Wisely, the sickly shrubs that had struggled for life here and there in the churchyard have been removed, and a variety supplied by Messrs. Veitch. The dry summer has been unfavourable in its effects on some, such as the Aucubas and Rhododendrons. The Firs also seem to find the Chelsea air too relaxing. Annuals, which in London frequently prove failures, have done fairly well in St. Luke's Gardens during the first season. There was a fine display of Stocks and Tropæolums, also of the favourite Mignonette. There have been planted some Sweet Briar Roses, but they probably will not bloom, though there are Roses that will produce buds in London.—J. R. S. C.

## INULA GLANDULOSA.

THIS is a general favourite amongst the stronger growing herbaceous plants suitable for our trying seasons, and yet it is remarkable how seldom we see it as it ought to be. We have been told it was difficult to cultivate, but this we believe to be more a question of position than any fastidiousness on the part of the plant itself. Where the soil is light,

sandy, and consequently very hot and dry during summer, *Inula glandulosa* will require a perfectly shady spot; indeed, the plant is always more robust and free-flowering if planted on a north exposure, where the sun's influence is hardly ever felt. In localities, however, where the soil is stiff and clayey it may be best to plant in full exposure, the main essential being a cool medium for the roots. It increases very rapidly by offsets, by which means it may be propagated to almost any extent, lifting and dividing the plants in autumn, firming the soil well about the roots when replanting. The accompanying woodcut (fig. 35) gives a good idea of the size of the flowers, the numerous ray florets being cut up into narrow strips, deep orange-coloured, and surrounded by a peculiar brown hairy involucre. As



Fig. 35.—*Inula glandulosa*.

a border plant it is amongst the finest for summer display, the blooms lasting a considerable time in perfection. It is a native of the Caucasus.—M. S.

## AROUND NEWCASTLE-ON-TYNE.

### SOUTH SHIELDS PARKS.

THERE is little of special horticultural importance in South Shields, but since the population has advanced so rapidly the local authorities awakened to the necessity of providing some open spaces for the recreation of the inhabitants and visitors, two public parks being the result. One of these, the North Park, is situated on low ground to the left of the entrance to the pier; the other, the South Park, being on a higher level, has admitted of rather more picturesque treatment, and though it is yet in an incomplete state the work is sufficiently advanced to indicate the character of the design. In the North Park little more could be done than provide spacious paths for promenade with lawns, and a few shrubberies for protection. Some diversity and interest are, how-

ever, imparted to the place by the rockeries introduced, one of which is cavernous in its structure; a few flower beds also brighten the summer effect. The principal strength is, however, being concentrated upon the South Park, and rightly, too, as a judicious liberality in expenditure could render this a very pleasant resort. The management of this Park has been entrusted to Mr. Peebles, and under his superintendence it has been rescued from a tract of waste land extending to the seashore. It required some courage to undertake the transformation of such a site into an ornamental garden and park, but a carefully considered plan was prepared, and is being steadily worked out with satisfactory results. The higher portion, which commands a good sea view, has been converted into a broad terrace promenade, with balustrades and flights of steps leading to the lower garden. The latter has been laid out in lawns and flower beds with bordering shrubberies and a small central lake. A convenient glass range is also provided for the propagation of the plants needed in bedding out, and also for the cultivation of indoor flowering plants. Facing the right hand side of the terrace is a considerable mound close to the sea, and this might be easily rendered a prominent feature treated as a rockery. As might be imagined in such an exposed position, fully open to the east and north-east winds, which during the winter months sweep along this coast so keenly, the greatest difficulty is experienced in finding evergreen deciduous shrubs and trees that will thrive, or even exist. There are some that will endure these trying conditions when well established, but in forming new plantations a large percentage of deaths must always be expected. If planted in spring when the March ordeal is passed they run the risk of being damaged during a hot dry summer before they can obtain a hold in the soil, and if planted in autumn there is poor chance of escaping the winter. Only those who have had experience in seaside gardening on such a coast as this can form an adequate idea of the vexatious difficulties that have to be overcome. The best plan is to employ some of the quick-growing Poplars, as protection for the less vigorous and smaller shrubs or trees, and the selection of these must be a very limited one. The common green Euonymus, Golden Elder, and Aucubas can generally be relied upon, but the hardest variety of the common Laurel is found to succumb at South Shields. Many others are being tried, but it requires a season or two to prove their qualities, and the shrubberies must necessarily present a rather thin appearance for a time.

At Westoe, which is still higher and nearly as much exposed, Mr. B. Cowan, the courteous superintendent, has had the same difficulties to contend with, the result being that he has had to rely almost exclusively upon the common Elder and its varieties. These have, however, been employed with considerable taste, and as they thrive most strongly under the conditions which are so injurious to other shrubs, it does not take a great time to form dense hedges or shady walks. One long path has been very successfully treated in this way, the common Elder, with the Parsley-leaved (*laciniata*), and the Golden variety being planted to form an avenue that is now quite luxuriant. Too much could scarcely be said in favour of the Golden Elder for exposed positions, and it amply deserves all that Mr. Cowan wrote respecting it in the paper read before the English Arboricultural Society some time ago. It grows freely, assumes a fine golden hue, and is highly effective either in masses or singly as dwarf or tall plants. At Westoe some long ribbon borders are backed up with yearling plants of Golden Elder not allowed to exceed a foot or so in height, and these have a capital appearance, a stock being raised every season for the purpose. It is an idea that might be advantageously followed elsewhere. The Cut-leaved Elder already mentioned might be employed more freely with advantage, as it is extremely graceful and was long ago designated by Loudon as "the handsomest of all the varieties." A golden form of this would be a grand addition to the list of useful seaside shrubs.

### SUNDERLAND PARKS.

This busy town, which until the present trade depression advanced so rapidly in size and population that it acquired the name of Mushroom Sunderland, has been well provided with parks for a considerable time, and as we have previously stated, it was in advance of Newcastle in this respect. Mowbray Park is situated near the Museum on the one side, and is bordered by the Ryhope Road on the other, this being the oldest of the public parks, as it was taken over by the town some thirty years since. It was originally an old stone quarry, and a steep escarpment 50 to 60 feet high has been utilised with excellent effect. The face of the rock is almost hidden by masses of luxuriant Ivy, which has taken full possession, clambering about freely, or hanging in festoons from projecting points. The upper part has been converted into a terrace with abundant seats, and from there a good view of the town is obtained. The lower portion, extending to the Museum, is tastefully laid out in lawns, flower beds, shrubberies, and a lake, constituting an agreeable summer resort for the people, as bands are provided several days in the week. Immediately adjoining the Museum is a handsome winter garden, erected by Mackenzie & Moncur about eight years ago. It is 140 feet long, very lofty, and of ornamental design, the interior being well furnished with specimen Palms and Tree Ferns, with numbers of smaller flowering and foliage plants of the usual decorative character. One end has been formed into an extremely pretty fernery, the other being chiefly used as an aviary, the central portion containing the largest specimen plants. Outside this is also a broad terrace, the inevitable accompaniment of all northern parks, and this overlooks the lower garden leading to the escarpment. Some distance from there near the sea at Roker, another picturesque park has been



acquired, but this is not quite finished. The lower entrance from the beach is through a passage in the rocks, and the whole surface is much undulated and diversified. When the trees and shrubs have made a little more progress the appearance of this park will be greatly improved, but even now it is very attractive in some parts. Both these are under the charge of Mr. Fergusson, a well-known horticulturist, and their condition is highly satisfactory from every point of view.

#### ASHBURNE HOUSE.

Following the Ryhope Road from Mowbray Park, about ten minutes' walk brings us to Ashburne House, the residence of Mrs. Backhouse, to which is attached a garden of a remarkable character, such as would never be expected in the midst of a populous town. The road here for a considerable distance is a favourite promenade, being overhung by lofty trees and constituting a beautiful shady avenue. Upon the right-hand side of this is Ashburne House and pleasure garden or park, the kitchen garden, glass houses, &c., being situated on the opposite side of the road. The park, for it fully merits that title, is about 40 acres in extent, and owing to its singularly diversified character it appears much larger. The house, a plain but substantial structure, is situated on the most elevated portion, and in front the ground dips rapidly to a long deep winding dell

lection is now a large one, but there are only a few varieties that can be relied upon. The best of all is Lord Suffield, which is an invariably good cropper, and the fruit reaches a good size. Kew's Codlin is but little less useful, and Warner's King is valued especially for jelly making, though it is not so free as the other two. Dessert varieties are not satisfactory as standards, either bearing very small fruits or failing to ripen. Trained to a wall at the end of the vinery is a Jargonelle Pear fruits well, and, no doubt, if the other walls could be utilised in the same way there would be no difficulty in securing a much larger supply of outdoor fruits.

The walks are extremely spacious, 9 feet wide, formed of Bridport pea gravel, and edged with stone, imparting a very neat appearance to the garden. The borders near the walks are occupied with a collection of choice hardy plants that is being steadily extended, those useful for cutting being in great demand. Carnations are a specialty at Ashburne, and Mr. Patterson, who besides being a careful practical gardener of wide experience is also an enthusiastic florist, has succeeded in raising some excellent seedlings, a scarlet self being one of the best border varieties we have seen. A large bed is devoted to them, the collection comprising most of the leading named varieties. Pansies are another specialty, and of these the collection is unusually rich for a private

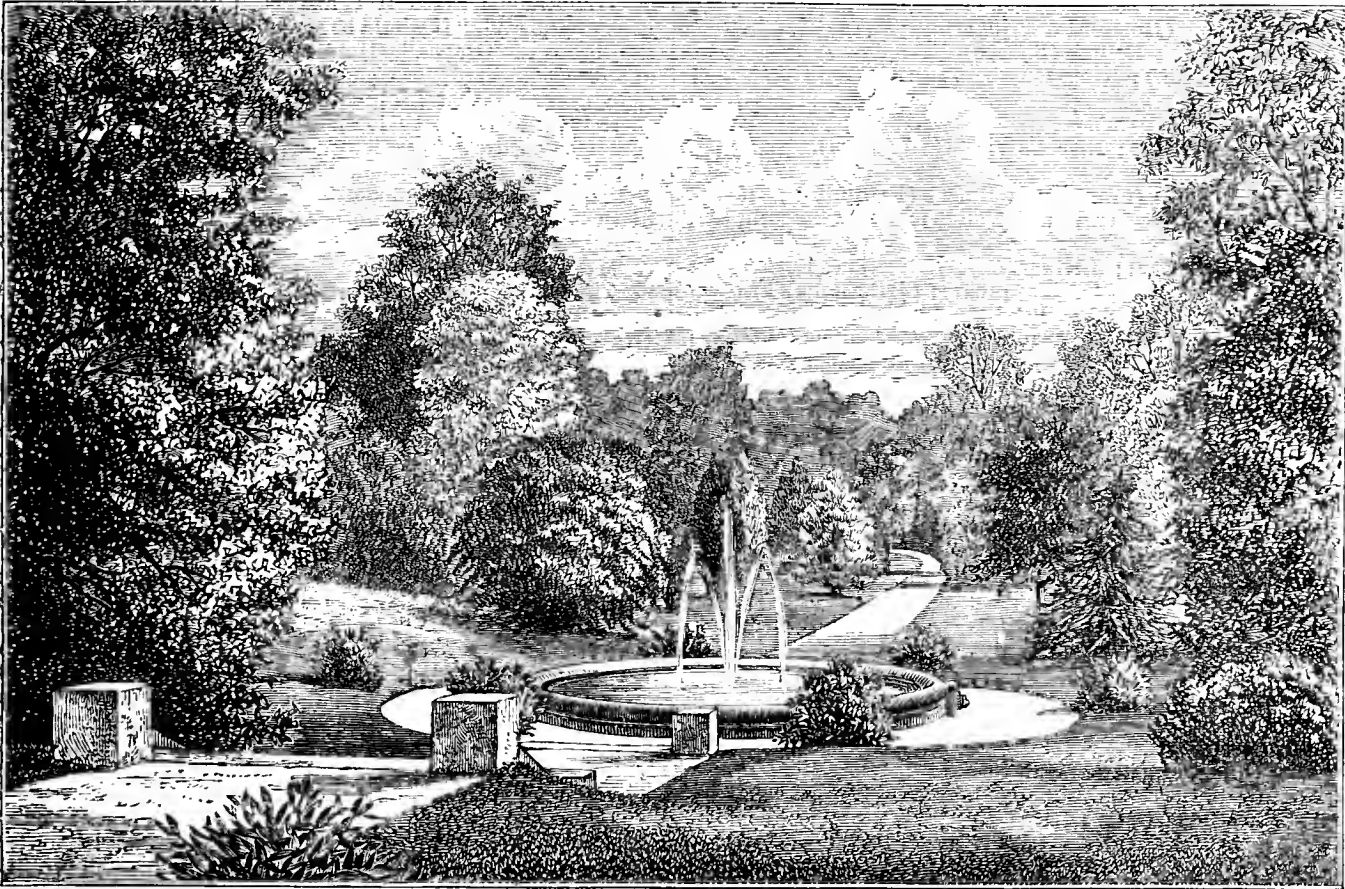

Fig. 36.—ASHBURNE HOUSE (VIEW IN PLEASURE GROUNDS).

or dene of the typical northern character. The slopes are covered with grass, very neatly kept, and a few charming vistas through the trees afford some pretty views from the house and the plateau upon which it stands. One of these is shown in fig. 36, but it is taken from a lower elevation and does not give an adequate idea of the distance. A path extends round the dene and crosses the streamlet or burn at several points by rustic bridges, and a walk along this enables the visitor to form some conception of the beauty of the garden. Trees and shrubs were plentifully planted some years ago; they have now attained considerable proportions, and owing to the sheltered position they occupy on the slopes have escaped much of the injury occasioned by east winds blowing off the sea. The dell is naturally irregular and picturesque, the effect of which has been heightened by an appropriate system of planting, not only the most ornamental shrubs, but some of the stronger growing herbaceous perennials, while Wood Hyacinths, Primroses, and similar spring-flowering plants cover the ground in several places. During the summer months this garden is an extremely beautiful one, and it is scarcely possible to imagine oneself in such a town as Sunderland when wandering round the shady and secluded walks.

The kitchen garden is about four acres in extent, but so closely surrounded by lofty trees that vegetable culture is a matter of great difficulty, and besides that an extensive wall space is lost that might otherwise be profitably occupied with fruit trees. In consequence the supply of hardy fruits has to be obtained from standard trees that are rather uncertain, where the winters and springs are so severe, not so much perhaps from low temperatures as the east winds, the plague of this coast. Numerous varieties of Apples have been tried, and the col-

lection is now a large one, but there are only a few varieties that can be relied upon. The best of all is Lord Suffield, which is an invariably good cropper, and the fruit reaches a good size. Kew's Codlin is but little less useful, and Warner's King is valued especially for jelly making, though it is not so free as the other two. Dessert varieties are not satisfactory as standards, either bearing very small fruits or failing to ripen. Trained to a wall at the end of the vinery is a Jargonelle Pear fruits well, and, no doubt, if the other walls could be utilised in the same way there would be no difficulty in securing a much larger supply of outdoor fruits.

The glass houses comprise a range of vineries in five divisions 150 feet long, the vines in which have done good service some years ago before Mr. Patterson took charge, but are past their prime now, and their places should be taken by young vines. A span-roofed stove contains a number of flowering and foliage plants, *Pancreatium fragrans* being a great favourite. Most of them are placed three together in a 12-inch pot, and such specimens bear three fine trusses of ten or twelve large pure white fragrant flowers each. Several fine specimen Palms and Ferns are also included in this house. A collection of Orchids has been formed in the past few years, and now comprises a large number of species and varieties, the plants all being in excellent condition. For instance, there are some eighteen distinct *Dendrobiums*, twenty *Cypripediums*, besides numbers of *Cattleyas*, *Laelias*, *Oncidium*s, and other genera. *Calanthe Veitchii* and *vestita* are thoroughly well grown, the growths made this year being remarkably strong and promising. *Cœlogyne cristata* is also treated very successfully, its flowers being valued for cutting. A Peach house, greenhouse, and miscellaneous pits and frames complete the producing accommodation, from which con-

siderable supplies are annually required. The garden altogether is in excellent condition, and Mrs. Backhouse may well be proud of her unique urban home.—L. CASTLE.

### CHISWICK TRIALS OF TOMATOES.

THE result of the Chiswick trials of Tomatoes has tended to reduce the chaos of names to something like order. The plants were grown out of doors on a south border under a wall, and as all received the same treatment the experiment is a conclusive one. The name printed in italics is the original under which each variety was first introduced, and the Fruit Committee of the Royal Horticultural Society have adopted it as the standard by which the variety shall henceforth be known, all the others being merely synonyms.

Those marked \* received a first-class certificate.

- 1.—*Open Air* (Laxton); Faultless Early (Farquhar).
- 2.—*Early Dwarf* (Vilmorin); Orangefield (Veitch); Orangefield Improved (Rutley & Silverlock); Little Gem (Veitch); Conqueror (Veitch); Early Red (Vilmorin).
- 3.—*Large Red* (Veitch); No. 1 (J. Banstead); Sensation (Webb); Canada Victor (Farquhar); Glamorgan (Hurst); Cooper's Dwarf Prolific (Cooper); Wheeler's Prolific (Wheeler); Nisbet's Victoria (Sharpe).
- \* 4.—*Horsford's Prelude* (Horsford & Pringle).
- 5.—*Paragon* (Farquhar); Eclipse (Sharpe).
- 6.—*Chiswick Red* (R.H.S.); King Humbert (Rutley & Silverlock); King Humbert (Veitch).
- 7.—*No. 1* (Watkins & Simpson).
- 8.—*Pear-shaped* (Farquhar); Nisbet's Victoria (Veitch).
- 9.—*Cherry shaped* (Farquhar).
- 10.—*Hathaway's Excelsior* (Farquhar); Emery (Farquhar); Hathaway's Excelsior (Veitch); Key's Prolific (Veitch); Large Smooth Red (Farquhar).
- \* 11.—*Perfection* (Farquhar); Livingstone's Perfection (Rutley and Silverlock); Livingstone's Favourite (Farquhar); Livingstone's Favourite (Dean); Perfection (Veitch); Reading Perfection; President Cleveland (Farquhar); Cardinal (Farquhar); Stamfordian (Veitch); Mayflower (Veitch); Optimus (Benary); Red Tomato, from Sandwich Islands (Carter); Webb's Jubilee (Webb); Jubilee (Nutting).
- 12.—*Haekwood Park Prolific* (Veitch); Invicta (Veitch); General Grant (Farquhar); No. 3 (Watkins & Simpson); Trentham Early (Veitch).
- 13.—*Trophy* (Farquhar); Trophy (Veitch).
- 14.—*Hepper's Goliath* (Veitch).
- 15.—*Acme* (Veitch); Acme (Farquhar); Acme; Brookwood A1 (R. Lloyd); Early Essex (Farquhar); The Pomegranate (Sharpe); No. 2 (J. Banstead); Livingstone's Beauty (Farquhar).
- 16.—*Vick's Criterion* (Veitch).
- 17.—*The Mikado* (Watkins & Simpson); The Mikado (Farquhar); Universal (Veitch).
- 18.—*Plum-shaped* (Farquhar).
- 19.—*Yellow Cherry* (Farquhar).
- 20.—*Greengage* (Farquhar); Greengage (Veitch).
- \* 21.—*Golden Queen* (Williams); Yellow Tomato (J. Smith).
- 22.—*Blenheim Orange* (Carter).
- 23.—*Prince of Orange* (Hurst).
- 24.—*Large Yellow* (Farquhar); Large Yellow (Veitch).
- 25.—*White Apple* (Farquhar).
- 26.—*Currant or Grape* (Farquhar).

### JOTTINGS FROM BATH.

BATH is so well known as a great horticultural centre, so many first-rate growers and exhibitors have hailed from it and its vicinity, and its flower shows are so well known and so highly appreciated, that there must be, and indeed is, always a great deal of interest to any visitor at any, even the deadest season of the year; would not, then, there be a good deal worth seeing in the month of August? And so, after my pleasant visit to Mr. Gray, I put myself under the kindly and hospitable guidance of my friend Mr. Cater, so well known to horticulturists who affect the fair "Queen of the West." I spent a very pleasant and instructive time, and as the items of information that one picks up are oftentimes useful to many readers, a few notes on what I saw may not be unacceptably. I must not pass by Mr. R. B. Cater's own garden at

#### AVONDALE.

This is remarkable in many ways. It is situated almost in the centre of Bath, yet here has Mr. Cater grown and exhibited many excellent things, perhaps his most successful productions being his pot Roses in the early part of the year, and Chrysanthemums in the autumn, and in both of these there were signs of coming victories and proofs of successful culture. His pot Roses were indeed grand specimens. Such kinds as Souvenir d'un Ami, Celine Forestier, Catherine Mermet, Marie Van Houtte, Charles Lawson, Jean Ducher, Rubens, and others were represented by plants from between 4 to 5 feet through, and must when in flower in the house devoted to them be a grand sight. Although an ardent lover of Roses and a thoroughly good judge of them, Mr. Cater gives up as hopeless the attempt to grow them in the open, where he is so shut in as in Henrietta Park, and so takes his revenge by growing pot Roses. He is, however, evidently hankering for some place outside the city where he can grow them. The Chrysanthemums were

in fine condition. Mr. Cater's collection is a very varied one, and comprises the best flowers in all sections; and in the very excellent Chrysanthemum Show held in Bath he rarely fails to take a foremost place. He has also a choice collection of Pelargoniums, while he has also a good collection of fruit trees. Like most places one sees, there are symptoms of extension, and a new house of considerable size testifies to the fact that the owner's zeal for horticulture is not on the decline. Under Mr. Cater's guidance our next visit was paid to a very remarkable garden, that of Alderman Chaffin,

#### LARKHALL,

A garden whose exploits are well known to all fruit lovers who read the Journal, for its able and intelligent gardener is Mr. W. Taylor, who has written so much and so ably on Grapes, and who has illustrated his theories by his practice both when he was at Longleat and in his present situation. I had once (although I had forgotten it) met him many years ago on a well-remembered occasion when the field marshals of the Journal entertained the colonels, captains, and subalterns at the "Star and Garter," Richmond. Ah, me! how many have passed away of that company since then; but I had never had the pleasure of talking with him until the other day. I was most struck with the modesty and ingenuousness of his character. He could hardly be got to talk upon the wonderful results he had accomplished in Grape culture, and in speaking of Longleat he asked if I had been there. On my replying in the negative he said, "It would be worth your while going there, if only to see the crop of Grapes." How often have I heard other sentiments expressed. A gardener comes into a place, and the first thing he does is to decry all that his predecessor has done, and to make it appear, if there is anything worth looking at, that it is all his doing. (Like some doctors who draw very long faces when they see a patient, tell how awfully bad he is, and then, when he gets better, take the more credit to themselves for the wonderful cure they have effected); or if he speaks of the place he has left in other hands, very much fears it is going all wrong, not as it was in his time. All gardeners do not talk thus, but some do.

The Grape-growing here is of a peculiar character, as it is almost entirely for exhibition, so that instead of seeing a house with a crop of Grapes weighing from 2 to 4 lbs. evenly distributed over it, here there were some four, five, to six bunches on the Vine, and these bunches from 6 to 7 lbs. in weight. The house itself is a remarkable one, and has gone through some striking experiences. The place is one of the sides of the many hills that surround Bath, and which, when twenty years ago the Alderman took possession of it, it was entirely bare. He planted a number of choice Conifers, which have done marvellously well—too well in fact, for they are crowding one another out. The owner lacks a little moral courage, and does not like to apply the hatchet. The best thing he could do would be to go away for a while, invite Mr. Gladstone to use his house, and to bring his axe with him; and I venture to say he would find the place considerably altered when he returned. Well, this vineyard, which is 140 feet long, is built on the side of the hill, and the hill, like most chalk formations, is famous for springs; so one fine morning word was brought in that a large portion of the bank had slipped and fallen against the house. The first thing was to get this away, and it was done not without some difficulty, and it was found that it had slightly altered the position of the house. A still more formidable thing was the roof. This was observed to be bulging, and a downfall seemed imminent. However, by timely employment of scientific methods this was saved, and the roof rendered apparently perfectly secure, but it still has a wavy appearance, and is not all on the same level. It was certainly a most wonderful sight to see the grand bunches of Muscat of Alexandria, Mrs. Pinee, Madresfield Court, and other fine Grapes in such marvellous perfection. Size and shape of bunch, colour of fruit, and size of berry all testified to make it evident that in Mr. Taylor the Vines had a master who could bend them to his will. The Vines were all young, only three years from the bud. The whole of the house was not devoted to Grapes; one end about 40 feet had a good collection of Tea Roses planted out, and the other end, also 40 feet, was at the period of my visit filled with Tomatoes, young vines coming on; but the interest of the place centres in the Grape culture, which I think will compare favourably with any that I have seen—and I have seen a good many places. I did not do as Alderman Chaffin told us a lady did who came to see them, one of those whose eyes are on the tips of their fingers, for they can never see a thing unless they touch it, deliberately drew her hand down a splendid bunch, exclaiming, "What splendid Grapes!" I am afraid most people would use rather unparliamentary language even to a lady when they saw the labour of a year thus thoughtlessly destroyed. What the Alderman did I do not know, but the lady, I imagine, must have felt considerably astonished at the statement made to her, and probably learned a lesson of "hands off." After an interesting conversation with Mr. Taylor we went off to see the nursery of

#### MESSRS. COOLING & SON,

and here there was much to interest those who love the Rose, for it is somewhat extensively cultivated here, and I had just seen such good specimens from here at the Taunton Show, that despite the drought and heat I felt sure that we should see something worthy of notice. We first visited the nursery proper, and here I saw two things of much interest—a crop of Cucumbers such as I had never seen before. I have seen pictures and what professed to be photographs, but I always gave credit to the imaginative power of the artist, but here they were in such profusion that it would have been almost impossible to have exaggerated.



Of course there may be other places where the same holds good, but I have not seen them. It is an improved variety of Telegraph, and the fruit I saw was hanging for seed, for which there is a large demand. Another noteworthy thing was the new Beauty of Bath Apple, which was certificated the other day by the Fruit Committee of the R. H. S. It is evidently a seedling from the Irish Peach, apparently crossed with Quarrenden. It has all the flavour of the former excellent Apple, but comes a month earlier; it is very pretty, and will, I doubt not, become a favourite dessert Apple. In an old house here there were some excellent plants of Maréchal Niel, from whence immense quantities of bloom had been gathered, and also of Reine Marie Henriette, which is treated in the same way as the Maréchal, and apparently with excellent results, the two colours forming a good contrast, especially if the brighter variety of Reine Marie Henriette can be obtained. Among Roses either new or unknown to me that I saw here were Florence Paul, a very bright coloured crimson Rose, very vigorous, and a good autumnal bloomer. It is said in Ketton's list to be a good garden Rose, but as I saw it here it was also an exhibition flower. Countess of Limerick, this was a pretty yellowish Tea, of whose history I know nothing, and one I never saw before, although Messrs. Cooling think highly of it. Louis Richard (Tea), a Rose of 1877, but which I have never to my knowledge seen before. It is a mixture of copper and rose, and was as seen here a very taking flower. Laurette, another old, very old Rose, as it was raised in 1852 and sent out by old Victor Verdier. I have never seen it exhibited except in Kent, where Mr. Wakley always exhibits it in good form. It may be described as a refined Homère with more yellow in it; it has the same tendency to come tipped on the edges, and I was glad to see that it was known in the west. Marshal P. Wilder is, I fear, nothing more than Alfred Colomb revived. One would hardly suppose that the distinguished firm who sent it out had palmed off an old Rose for a new one, and it is possible a seedling may have been obtained very like Alfred Colomb; but it has a suspicious appearance of being simply a vigorous form of that fine Rose; in wood, foliage, and flower they are positively identical. I fear with the examples we have had lately of American Roses we shall have to be very watchful. There was another bright red Rose of which I have no knowledge, Lucy Corbet, nor can I find it in the catalogues. There was also a grand lot of Asters, amongst them the new Washington Aster, very large, enormous, but I think somewhat coarse.

There were other noteworthy things in this garden. A great deal has been said and written on the subject of Lettuces. We were in the home of that fine old variety, the Bath Cos, and here Messrs. Cooling had a large breadth of seedling plants, the crop of which was just ripening. He calls it the Leviathan Bath Cos, and the demand for it is very great. Evidently we must be careful in condemning things from our own point of view alone. I had on the recommendation in the Journal procured the seed of Bossin Lettuce from Messrs. Vilmorin, but was so little pleased with it that I had determined not to grow it again; but here it was highly spoken of as an excellent summer Lettuce, not having a tendency to run away in dry seasons. From this we went into

#### DR. BUDD'S ROSE GARDEN,

which immediately adjoins that of Messrs. Cooling. Dr. Budd is known to all rosarians as a successful and enthusiastic exhibitor, and has been of late years taking a very foremost place. His garden exhibits another proof of what can be done in a favourable climate. When Dr. Budd took the place it was simply a morass. He has had to drain and restrain it, to raise up his beds to get the plants out of the way of the wet, and the result has been the success of which we all know. Nor has he gained the position he covets and means to have. Living so far south in an early situation he ought to be able to carry off the challenge trophy, and I hope that he will gain his object some day. He is also a very successful grower of Roses in pots, and generally takes the first prize for them at the Bath Show. His plants looked extremely vigorous and healthy, and I should find it difficult to prophesy whether he or Mr. Cater will carry off the chief honours next year. Many of the Hybrid Perpetuals, as well as Teas, in the open had abundance of flowers, some very good, and the greater portion of them not equal to the July standard, and with such experienced growers producing these results the absurdity of advocating autumn Rose shows is apparent.

Since these notes were taken I have had the pleasure of attending the autumn Show at Bath, and was no way surprised that Alderman Chaffin's Grapes had carried all before them, or that Dr. Budd's Roses obtained the premier place, or that Messrs. Cooling's Roses and Asters took a like position, but the Exhibition clearly proved how strong is the love of horticulture in and around Bath, and with what success it is carried out.—D., Deal.

#### JUDGING AT THE CRYSTAL PALACE.

MR. WARD well merits the thanks of his fellow exhibitors of fruit at the Palace for the able manner he has taken up their case as well as his own. The judging has become most notorious of late years. Only a few years ago Mr. Coleman was disqualified because two dishes of Peaches looked very much alike in outward appearance; but if the Judges had taken the pains to examine them the difference would have been as plain to them as it was to the uninitiated. Yet a year or two after the same Judges with greater experience could not distinguish genuine bunches of Grapes from those with false shoulders bunglingly tied on, but when the growers and exhibitors were admitted it was very soon discovered.—A DISHEARTENED EXHIBITOR.

MR. WARD seems to be very proud of the Grapes he showed at the Crystal Palace. He would even represent himself (with a few of his bosom friends) to be better judges of Grapes than Mr. Barron and his colleagues. Mr. Ward may think so himself, but he has not gained the favour of the public so far as to make them believe it yet. I think Mr. Ward would be wise to be silent for the future when he does not get the award that he wishes, and take the decision of the Judges as final, the same as many as good a man as he has had to do before.—SCOTCHMAN.

ALLOW me to ask my fellow readers which of the sets of names deserve most confidence, those given by you as judges, or those given by Mr. Ward as exhibitors and growers. I consider the sarcastic remarks of Mr. Barron quite uncalled for, and ought to be withdrawn. I regret to see that even this year is not to pass away without some unpleasantness, and these disputes serve no good purpose. It is generally understood that both managers and judges are often put to their wit's ends in their endeavours to satisfy everyone, and it is no uncommon thing to find they fail to please anyone. They provide classes for all, from a four-dish up to a fifty-dish collection. A few years ago there was a couple of large exhibitors, but last year there were seven exhibitors, showing over 300 dishes, and filling a line of tables the whole length of the transept allotted to fruit. This alone attracted more attention than all the rest of the Show. And well it might, as it was a sight perhaps never to be seen again. Then we see eighty bunches of Grapes staged in the twenty-bunch class. This shows that quite half the Exhibition was filled with these two classes, costing about £44; the other half, made up with smaller classes, costing £160. So let us hope that managers of shows will continue to encourage the large classes, but let them secure practical men for judges. This at least will satisfy —W. R.



#### ORCHIDS AT EASTWOOD PARK, THORNIEBANK, N.B.

THE scarcity of Orchids at our September exhibitions makes it very apparent that this is not a good month to visit gardens, unless the collections are of more than ordinary value. The collection at Eastwood Park is so large and varied that it well repays a visit at any time of the year. David Tod, Esq., the proprietor, is well known as a most enthusiastic orchidist, while his gardener, Mr. Ewart, is most successful in the culture of the splendid collection he has in charge. Cool Orchids are the favourites, and fill several houses, *Odontoglossums* very largely predominating. A large specimen of *O. Pescatori*, carrying over 300 blooms on five spikes, is worth going a long way to see. This is a very distinct variety of a graceful drooping character. Dozens of smaller plants were in bloom, all of good forms, but more erect in spike than the large plant. *O. tripudians* was well represented; sepals very dark, and base of lip pure white, a splendid variety. *O. Ruckerianum*, a large spike; *O. Uro-Skinneri*, a very fine dark variety, several plants of which were in bloom; *O. Halli leucoglossum* was very beautiful; *O. Andersonianum*, a fair variety; plants of this have pseudo-bulbs 4 inches in diameter; *O. Coradinei*, very fine, carrying two long spikes; *O. ramosissimum* with two large spikes; *O. grande*, *O. madrense*, and *O. Lindleyanum*, a particularly fine form, and many fine forms of *O. Alexandræ*, several spikes were showing fifty blooms each. A plant of *O. Alexandræ* that bloomed here last summer had a spike with 120 blooms on it fully developed; a variety I measured had blooms 5 inches in diameter.

*Epidendrum vitellinum majus* is largely grown. This is a late flowering variety, very distinct and beautiful. Among *Cattleyas* *Harrisoniana* and *Gaskelliana* were blooming. A dozen nice plants of the beautiful *Lælia Dayana* were flowering profusely. *Mesospidium vulcanicum* is largely grown in hanging pans near the glass, and looks very pretty. Flowering very freely were two huge specimens of *Maxillaria grandiflora*. *Oncidium macranthum* and *serratum* were trained along the roof of the *Odontoglossum* house, the spikes being 10 feet long, and profusely covered with flowers. *Masdevallias* are a feature here too, but this is not the season for seeing them.—G. R.

#### ORCHIDS AT WESTBROOK, SHEFFIELD.

NUMBERS of very choice and rare Orchids are now flowering at this place, amongst them being a fine plant of the beautiful new *Odontoglossum Harryanum*, which has been in flower since August 30th. *Odontoglossum Alexandræ Eckhardti* is also a very fine hybrid, singularly and beautifully coloured. *Vanda Sanderiana* is carrying a spike of eight flowers each  $4\frac{1}{2}$  inches across, and is strikingly effective. *Lælia elegans prasiata* is a very distinct



variety, sepals a greenish orange, petals orange shaded mauve, lip a rich purple. The rare and pretty *Cypripedium Fairricanum* is carrying three flowers. *Cypripediums Godefroyæ*, *œnanthum*, and *Spicerianum* are also flowering and are all beautiful. Amongst other choice plants now in flower are *Cattleya Gaskelliana*, several very fine vars., *Lælia Dayana*, *Odontoglossums Uro-Skinneri* and *bictonense*, *Miltonia virginalis*, and *Cœlogyne Massangcana*, a plant of the latter in a basket, with three fine flower spikes, is very beautiful.—W. K. W.

## ROYAL HORTICULTURAL SOCIETY.

SEPTEMBER 27TH.

DAHLIAS and Tomatoes were the two great features of this meeting, the former being represented by large collections from the principal nurserymen, and the latter by specimens of a large number of varieties from the Society's Chiswick Garden. Particulars of these will be found in another page, but so many lists of Dahlias have been given this season that we have not named any of those shown beyond the varieties certificated.

FRUIT COMMITTEE.—John Lee, Esq., in the chair. Present:—Messrs. Blackmore, Woodbridge, Bunyard, Barr, Pearson, Miles, Crowley, Norman, Fitt, Lane, Ford, and Dr. Hogg. Mr. Howe, Benham Park Gardens, and Mr. Sanson, Selworthy Park, Honiton, sent seedling Melons, both of which were passed. Mr. Bowers, Castle Hill Gardens, Cerne, sent a dish of Nectarines to be named which were Pitmaston Orange. Mr. G. Bunyard sent a seedling Apple, raised by Mr. Graham of Cranford, called Graham's Royal Jubilee. It is a large good-looking cooking Apple, some specimens of which were baked for the use of the Committee, but it was not considered superior to other varieties in cultivation. Messrs. Cheal & Sons of Crawley exhibited fruit of the American Cut leaved Blackberry, which was large and ornamental, but devoid of flavour. Mr. Thomas Baines of Palmers Green sent a dish of Trumpington and Scotch Bridget Apples. Mr. Barron exhibited from the Society's Garden at Chiswick a dish of Chasselas Vibrant Grape, and also one of Royal Muscadine, showing the greater earliness of the former, which when growing in the same house is a fortnight earlier than Royal Muscadine; also bunches of Foster's Seedling, Miller's Burgundy Esperen, Ferdinand de Lesseps, and Diamant Trauhe.

At a meeting of the Fruit and Vegetable Committee held at Chiswick, September 21st—present: John Lee, Esq. (in the chair), Messrs. Barr, Miles, Burnett, Fitt, Bunyard, Pearson, Norman, and Lane—the Committee examined the collection of Potatoes growing in the gardens. The following varieties, selected as possessing good appearance and cropping qualities, were tested by cooking, and first class certificates awarded—viz.,

*Lord Tennison* (Fletcher).—Round flattened, purple-flaked, rough skin, white flesh, good quality.

*Day's Sunrise* (Day).—Early White round, clear rough skin, white flesh, good cropper.

*Maincrop Kidney* (Johnson).—White kidney, clear rough skin, white flesh, good cropper.

*Early White Beauty* (Webber).—White round, clear rough skin, white flesh, good cropper.

The Committee inspected the collection of Tomatoes grown in the open ground, the following varieties being selected as "types," and awarded three marks each—viz.,

*Perfection*.—Fruits large, smooth, round; red.

*Horsford's Prelude*.—Fruit's medium, oblate, smooth, deep red, very freely produced.

*Open Air* (Laxton).—Fruits medium, flattened, and somewhat corrugated, early and free bearing.

*King Humbert or Chiswick Red*.—Fruits oblong, angular, red, great cropper.

*Golden Queen*.—Fruits large, smooth, orange-yellow.

For list of Tomatoes grown and classified (with synonyms) see list (page 276).

FLORAL COMMITTEE.—Present: Shirley Hibberd, Esq., in the chair; and Messrs. W. Goldring, H. Bennett, H. Herbst, G. Duffield, G. Paul, J. Fraser, R. Dean, W. Holmes, C. Noble, H. Ballantine, J. Dominy, H. M. Pollett, A. F. Lendy, T. Baines, E. Hill, B. Wynne, J. Douglas, W. Wilks, J. Walker. Messrs. Paul & Son, Cheshunt, contributed twenty boxes of Dahlias, single, Pompon, Show, Fancy and Cactus varieties, a magnificent collection, for which a silver-gilt medal was awarded. Mr. T. S. Ware, Tottenham, sent a beautiful collection of Pompon and single Dahlias, very bright and varied in colours. A number of Cactus and bedding varieties was also shown, and several bunches of hardy flowers. Mr. J. T. West, gardener to W. Keith, Esq., The Cornwal's, Brentwood, exhibited eight stands of Show and Fancy Dahlia blooms, exceedingly fine substantial blooms (vote of thanks). Messrs. H. Cannell & Sons, Swanley, had several handsome Cactus Dahlias and flowers of Tuherous Begonias. Mr. C. Turner, Slough, sent a stand of new Dahlias, comprising several good varieties, one of which, *Plutarch*, was certificated. Messrs. Rawlings Bros., Romford, Essex, showed about 120 blooms of Show and Fancy Dahlias, representing a large number of varieties (bronze Banksian medal). Messrs. J. Cheal & Sons, Crawley, contributed a pretty collection of single Cactus and Pompon varieties of Dahlias, including large number of choice new varieties raised by this firm (bronze medal).

Sir Trevor Lawrence, Bart., M.P., Burford Lodge, Dorking (gardener, Mr. Bickerstaffe) sent a small group of Orchids, comprising *Odontoglossum Reichenheimi* (cultural commendation) with a panicle of over fifty flowers, the sepals and petals barred with deep brown, the lip purple at the base, white at the upper part; *Epidendrum xanthinum*, bright yellow; *Cœliopsis hyacinthina*, with small white flowers from base of the plant; *Cattleya Gaskelliana superba* (vote of thanks). F. G. Tautz, Esq., Studley House, Hammersmith (gardener, Mr. Cowley), exhibited several Orchids, including the green-flowered *Cataseham costatum* and *Cypripedium marmorophyllum*. H. S. Smith, Esq., Cobham (gardener, Mr. Quarterman), was awarded a cultural commendation for *Dendrobium formosum giganteum*, with a head of eleven large flowers.

Messrs. J. Veitch & Sons, Chelsea, exhibited plants of the interesting

and beautiful hybrid *Begonia John Heal*, for which a vote of thanks was awarded. The flowers are bright rose, produced very freely, and last a long time. Mr. F. Perkins, The Nurseries, Leamington, was awarded a vote of thanks for plants of *Solanum capsicastrum elegans*, dwarf and freely fruited. Mr. S. Allen, Northenden Road, Sale, Cheshire, was adjudged a cultural commendation for a remarkably well grown *Nephrolepis Duffii*, nearly 3 feet in diameter. Mr. J. Goody, Bilchamp, Suffolk, sent several seedling Dahlias, with flowers of Juarez. Mr. A. Duncan, Kendal, sent a plant of *Adiantum cuneatum Hartleyanum*, a variety with small pinnules. Mr. M. Smith, 12, Queen Street, Kilmarnock, showed sixteen spikes of *Gladioli*, very handsome (cultural commendation). Mr. J. Chambers, Spring Grove, Isleworth, was awarded a vote of thanks for plants of a white *Viola*, named *Stowflake*, of good size and free. Mr. R. Dean, Ealing, had a similar award for *Dianthus Heddewigi* Snowhall, and *Gaillardia picta* Unique.

## PLANTS CERTIFICATED.

*Dahlia Canterbury Tales* (Paul & Son).—A single variety, rich crimson, shading to purple at the tips of the florets.

*Dahlia Mrs. Harry Whitfield* (Paul & Son).—A single variety, brilliant yellow, capital shape.

*Dahlia Frank Pearce* (Rawlings Bros.).—A fancy variety of a light rosy crimson hue, with a few dark crimson streaks.

*Dahlia Plutarch* (C. Turner).—A fancy variety of good form and distinct colour, orange buff streaked crimson.

## SHOWING AND JUDGING FRUIT.

AN "Old Hand" contributes a very good letter on this subject on page 522, and adduces evidence in favour of the continuance of very large prizes for very large collections of fruit. I have not the Journal at hand to refer to, but believe I stated in the article that an "Old Hand" criticises so fairly, that when there was good and genuine competition in classes of a sensational nature that was a sufficient justification for their provision and continuance. We are thus in accord on that subject. What I desire to mainly point out is this, that when extraordinary sums are offered for an extraordinary number of dishes the great bulk of the prizes in schedules must of necessity be disproportionately small, while many good cultivators can compete in these and only few in the former. When a prize of £50 brings three competitors only out of the thousands of good gardeners in Britain it is in my view a failure, except in so far that the sensation attracts the gaping crowd of sightseers. An amount like that prohibits free competition. In the Newcastle instance I suspect it ostracised a whole community—namely, of vegetable growers. There appears to have been nothing left for these, yet is it not as important to encourage the production of high-class vegetables as of fruit and flowers?

I hope I did not suggest that superior fruit is not staged in classes that are intended to be sensational. It is readily conceded that the best of examples may be found there; but what do we find in addition? We find plenty of dishes arranged to make up the requisite number that are not superior to the produce staged by cottagers at a good show. This is not adduced as derogatory to great exhibitors who cannot help themselves in the matter, and they do and must scrape together the best they can to meet the conditions imposed.

It is most creditable to Scottish growers that they exhibit in such numbers in large classes, and that they exhibit well is admitted. My point is this. When the competition is so good it would be better to increase the number of prizes in those classes than to divide an exceptionally large sum between two or three individuals whether the competition be keen or not.

I daresay an "Old Hand" knows as well as I do that a class of twelve dishes of fruit is easy to compete in, or the reverse, according to the stipulations. If every dish has to be of a distinct kind of fruit the competition will be limited, as the whole of the fruits will not be of high class quality, but if duplicates are allowed distinct in variety, such as black and white Grapes, dark and light Plums, and so on, the field of competition is widened and the collections generally improved. A collection of twelve dishes may be easier to compete in than one of eight dishes, and too much care cannot be exercised by the framers of schedules in distinguishing "kinds" and "varieties," so that intending exhibitors may know exactly what to do to make themselves safe against disqualifications.—EXPERIENTIA DOCET.

## HILL HOUSE, LANGPORT.

THIS, the residence of Vincent Stuckey, Esq., is situated close to Langport, and well above the large tracts of low-lying land that surrounds that quiet little town. No place that I have visited this season has suffered so much for want of rain, none having fallen, to any appreciable extent, from February till the end of August. As a consequence the lawns, flower gardens, and park were looking very brown indeed, this naturally marring the appearance of what is really a pretty well-kept place. Adjoining the house, and overlooking a flower garden, stands a commodious and well designed conservatory, which contains an aviary, and is kept constantly filled with a good selection of climbing fine-foliaged and flowering plants. A noble plant of the very ornamental or servicable *Kentia Fosteriana* and good *Dicksonias* form admirable centres of groups, and about these are arranged plenty of *Fuchsias*, *Marguerites*, *Achimenes*, *Coleuses*, *Pandanuses*, dwarf *Scabious*, and *Calliopsis*. The two last named annuals are well adapted for pot culture, and remain in flower for a considerable length of time. The double pink Ivy-leaf *Pelargonium Madame Crousse* is very effective for

furnishing hanging baskets; in fact, nearly all in that section are well adapted for that purpose.

In the flower garden neither the flowering or fine-foliaged plants were so good as usual, these presenting a very different appearance to what I have previously seen in these gardens. A large bed filled with *Agave americana* intermingled with scarlet *Pelargoniums* was quite a feature, and looked well from the first filling of the beds. The carpet beds were neatly done and kept in good order, as they should be, or not attempted. *Pilea muscosa*, or the Artillery Plant, is here used as a green-foliaged carpeting plant, and quite surpasses for effect any other kind tried. It is easily propagated, and when planted of very neat habit, the colour being a pleasing pale green. Considerable numbers of flowering plants are also grown in the kitchen garden, one of the most effective of these for front rows being the miniature *Asters* planted thickly.

The forcing, fruit, and plant houses are situated on the opposite side of the road, and on the whole may be said to be a useful lot of glass. There are several small span-roofed houses, one being principally occupied with a healthy lot of *Camellias* planted out, the end being wholly covered with the useful and ever-flowering *Solanum jasminoides*. In another house *Abutilons* are planted out and trained in different ways, these again yielding a continuous supply of flowers. A back wall clothed with Ferns, including the pretty *Lygodium scandens* and the free spreading *Nephrolepis exaltata*, may be said to be both ornamental and useful, this being the means of supplying abundance of greenery for vases and other purposes. The borders near the pathways in the fernery are covered with rockwork, among this being planted a quantity of *Adiantums* and other Ferns—a method of obviating an eyesore which is well worthy of more general imitation. It is almost impossible to grow too many Ferns anywhere, and these banks and walls clothed with them save the pot plants surprisingly. *Panicum variegatum* is also pretty and effectively intermingled with the planted out Ferns, and is also found very serviceable for cutting from. *Stephanotis floribunda*, *Dipladenia boliviense*, and *Allamanda Hendersoni* are the principal roof plants in the stoves, and all are doing well. *Gardenias* planted out in a narrow well raised border are in good health and clean. A compost consisting of nearly all peat best suits them. *Tydeas* in variety, grown in small pots, flowered most abundantly for several months; this class of plants ought to be more frequently seen. *Eucharis amazonica* in quantity, and a good number of the beautiful *Pancreatium fragrans* are doing well. and I noticed some capital plants of *Dendrobium nobile* in baskets, Tuberous and other *Begonias* are well grown, and there is also a good assortment of *Crotons*, *Dracenas*, *Palms*, and other plants for the dinner table.

Since Mr. J. Lloyd has had charge of these gardens a most marked improvement has been effected in the fruit-growing department. Lifting and root-pruning coupled with the gradual formation of new borders was never attended with better or more rapid paying results. The natural subsoil is a heavy retentive clay, and directly the roots of fruit trees reach this the effect is soon apparent. Peach trees have the "yellows," and do not perfect good fruit, while the Grapes do not ripen their wood satisfactorily, and shanking is the order of the day. Mr. Lloyd went boldly in for renovation in every case while the leaves were yet fresh and green, or before September was past. In the case of the house of Muscat Grapes, the whole of the roots worth preserving were carefully separated from the bad soil and actually fastened to the roof trellis, while the bottom of the border was drained and the old heavy compost replaced with new. Every precaution was taken to keep the roots as well as the foliage shaded from sunshine, and they were also frequently moistened with a syringe. The roots were carefully relaid into the fresh compost, the latter being kept well moistened, while the foliage was shaded and very frequently syringed. This treatment preserved the foliage for some time, or while it assisted to form a few fresh root fibres, and the wood ripened off well. The following season the Vines were gently forced, and all perfected comparatively heavy crops of Grapes of surprisingly good quality. How good they were may be gathered from the fact that three bunches were exhibited at the Taunton Show early in August, and in spite of strong competition easily secured the first prize. The other houses containing *Alicante*, Mrs. Pinee, Gros Colman, Lady Downe's, Foster's Seedling, and Black Ham-burgh, have all undergone a renovating process, though not in all cases so severe as that accorded the Muscat of Alexandria, and in every instance the practice has answered well. All the sorts named are still doing well, but in one or two instances it is thought the roots have left the borders (all inside) and found their way into less congenial soil. These will be wholly or partially lifted this season. It is a practice to be commended to many other gardeners in charge of unhealthy Vines, but this kind of work must be done quickly and well, and those responsible are warned not to overcrop the Vines, especially for a season or two following wholly or partial lifting.

The Peach houses, in common with the vineries, are roomy, well-arranged houses, and plenty of good fruits are gathered from the fine trees there to be seen. The favourite sorts of Peaches are Royal George, Noblesse, and notably the Alexandra Noblesse, and Walburton Admirable. The old Elruge Nectarine is still much liked, but fresh sorts are being gradually introduced. A Peach case designed and constructed by Mr. Lloyd promises to be a very profitable structure. Useful plants of Melons in various stages were growing in the houses, the favourite sort being High Cross Hybrid. Strawberries in pots are established early without much trouble. The runners are taken off the old plants as soon as they can be procured and dibbled into shallow boxes of good soil.

Set in a cold pit and lightly shaded they soon become strong and well rooted, being eventually transferred direct to the fruiting pots.

The kitchen garden is principally situated on a steep hill, and as may be imagined is very difficult to manage during a dry season. All things considered it was well stocked with vegetables, which only wanted rain in several cases to start them into more vigorous growth.—W. I.

### FACTS ABOUT FRUIT.

WRITING in an evening contemporary, Mr. Sampson Morgan has the following jottings respecting fruit, fresh and preserved:—

Although our climate and soil are suitable for the production of choice fruit in abundance, yet it is nevertheless a fact that we grow only enough for about a three-months supply, and for the rest are dependent upon the consignments from abroad. True, we cannot raise such tropical fruits as the Pine Apple and the Banana in the open air, but we can produce such nutritious and medicinal fruits as Apples, Pears, Tomatoes, Plums, and Nuts in profusion, and to such an extent as would enable us to be almost independent of foreign fruit of any kind. In spite of what we raise, it is a fact that in one year the value of the total imports ran up to considerably more than £7,000,000, which may be divided as follows:—Apples, £717,031; Oranges and Lemons, £1,481,010; fruit (raw), £1,421,747; fruit (dried and preserved), £558,777; Nuts, £447,295; Currants, £1,458,183; Figs, £187,903; Plums and Prunes, £94,742; Raisins, £966,220. Considering the consumption of fruits, both foreign and home grown, in connection with an increased annual production, it is pretty evident that we are becoming, as a nation, a fruit-eating people. With regard to Apples, although we have the finest climate in the universe for the production of the "king of fruits," as regards quality and quantity combined, yet it is a fact that from the States we import Apples to the value of £500,000; from Belgium and other continental countries to the value of £1,000,000; and from Canada to the value of £91,000.

FRUIT AS FOOD.—The increase indicated above is a good sign, for more reasons than one. Fruit must, by all thinking men who believe in the diet cure, be accepted, without any qualification, as being the proper food for man. The influence of fruit upon the system is not only marked, but untold. In fact, by its use we are enabled to mitigate or cure almost all the ills that flesh is heir to. The list of fruits—home grown alone—is endless. We may, as the seasons come round, go in for the Strawberry cure, the Grape cure, the Tomato cure, the Currant, Raspberry, and Cherry cure, the Apple, Pear, Melon, and Plum cure, and, independent of Nuts, yet not exhaust the list of luscious fruits grown. As to how fruit should be eaten, it were best for each one to decide for himself. Some reason that the skin of all fruits should be rejected, while others argue that most fruits should be eaten whole. For myself I reject most, if not all skins, with the exception of such fruits as the Currant and the Plum. A good rule may be found in the following plan:—

Do not eat your Peaches' and Apples' skin; all the skins are insoluble. Do not subject your stomach to the irritation of Grape and Cherry stones, or to Orange or Lemon seeds. Discard your Grape skins; do not eat Orange peels. The fleshy part of any of our fruits, when at a proper stage of development, can be eaten with great benefit. Plums do not digest as well as Grapes. The same is true of Cherries. Peaches contain a large proportion of soluble constituents, and are usually readily accepted by weak stomachs. Roasted Apples are slightly laxative, and are very acceptable. Pears are more digestible than Apples, and are a delicate and agreeable fruit. Gooseberries are wholesome, but should be cooked if eaten in any quantity. Raspberries and Blackberries are excellent, and should be eaten freely. Strawberries are probably the most heartily welcomed of our small fruits, and the least disturbing of any. Fruit has its best effect when eaten with brown wholemeal bread, not as dessert, but food. Sound, ripe fruit, in good condition, is very beneficial. The danger only arises when we partake of unripe, bruised, or unwholesome fruit. For instance, sour Apples, hard unripe Green Gages and Plums are positively dangerous eaten raw. "Nothing," says one doctor, "can do so much to make people independent of the profession as the daily use of fruit."

FRUIT FOR WINTER.—With regard to preserved fruits for winter use, from a dietetic point of view, we find that we are not able at present to put upon our tables soft fruits, such as Currants, Green Gages, and Plums, in fresh condition, with the exception of those that are put up in bottles, and which must be admitted to be a failure in their present form. We want to be in a position to have fruit that has simply been stewed down, and which contains only a small amount of sugar, if any. The fact is our jams and jellies contain too much sweetening matter to be wholesome, especially if eaten regularly or in large quantities.

The perfect preserve of the future for winter use will consist of fruit which is simply stewed down with as little sweetening ingredient as possible, and which, when turned out for use, has the appearance and flavour of the unsweetened fresh fruit. For such a preserve as this there would of necessity be an enormous demand, and whoever satisfies this demand will earn the gratitude of those who from one year's end to the other partake of fruit as food. Of course hard fruits, such as Apples, Pears, and Nuts, may be so utilised as to be in good condition almost from season to season; but with regard to soft fruit things are different. If we require them in winter, or after the season is over, they must be preserved, and until they are properly preserved in a healthful manner, it were best to confine ourselves to the use of hard fruits alone. If we

compare our system with that of the States, we find that there one of the leading industries in connection with horticulture is that of the winter utilisation of fruit. Fruit preserves—different from our jams—canned fruits, and fruit juices are the order of the day. Farmers grow special crops for the canneries, and the canneries cater in a wholesale manner for the public. In out-of-the-way districts the grower himself has his household fruit mill, fruit evaporator, or drier for the same purpose. Summer or winter every farm house has an abundance of fruit, fresh, preserved, or dried. Not only do they evaporate their Apple chips and rings, but also Plums, Peaches, Nectarines, Apricots, Cherries, Currants, Raspberries, Grapes, and Figs, so that they have all the year pure fruit in abundance. The system of drying and evaporating is simple, and the apparatus by no means dear. This being so, it is strange that it has not become popular here with the home-grower.

### INDIAN EXPERIENCES.

(Continued from page 257.)

THE block of forest called Deva Shola, or the Gods' Wood—from Deva, God, and Shola, a wood—was, before the advent of the Chinchona planter on the Nilgiris, by far the largest and finest piece of forest on the plateau. Large streams of water flowed through it, and an old road ran through its centre fringed with masses of Ferns, such as *Adiantum ethiopicum*, *A. hispidulum*, *Davallia tenuifolia*, *Pteris cretica*, *Lastrea aristata*, *Cyrtomium caryotideum*, and many others, whilst the ravines were filled with handsome specimens of a Tree Fern, *Alsophila latebrosa*. The Shola being situated so near the large station of Ootacamund, was a great resort of shooting and picnic parties. The wood consisted originally of from 800 to 900 acres of low but very thick forest, with a very dense undergrowth of a species of *Strobilanthus* with long interlacing stems, forming in many parts an impenetrable thicket, save for the lanes formed in it by the passage of deer and other wild animals. This famous wood was at one time the home of the tiger, bear, lambhur or large deer, leopard, wild boar, and other animals, which yielded magnificent sport to the residents and visitors to the Nilgiris. The wood was in fact a place of great note and quite a feature of the hills, and was also looked upon by the surrounding native population as a peculiarly sacred spot, the place of abode of their Gods, and where they retired to worship. It was therefore with horror and dismay that they received the news that 500 acres of the sacred Shola had by Government been given over to the ruthless hand of the Chinchona planter. Notwithstanding all this, however, when the time came for felling the forest the natives from the neighbouring villages of all castes, with a true oriental love for gain in the shape of wages, came crowding to the work of destroying the Shola, which had been held to be so sacred by their forefathers for so many generations. There can be no doubt that the destruction of this famous wood was a gross blunder. In the first place the Government were to blame in allowing it to pass out of their hands to the extent they did; and secondly, the parties to whom the land was conceded were even more to blame in ruthlessly sweeping the land of its covering of forest before having a single Chinchona plant ready to be put out, and neglecting to leave the all necessary belts of protecting forest as barriers against the annual gales of the south-west monsoon.

In due course I succeeded in raising some 600,000 sturdy young Chinchona plants, all of the *succirubra* species, in burning, clearing, and pitting sufficient land to receive these plants, and in building a substantial brick house on a grass ridge adjoining the plantation. All went well till what is called in India the "bursting" of the south-west monsoon, which proved to be the herald of a series of disasters. In the first place, on the second or third night of the monsoon the corrugated iron roof of the newly finished house was blown clean off and carried right away into a ravine below, causing me to seek shelter in an out-house. The gale continued for a fortnight with little or no rain, so that no planting operations could be undertaken. About a couple of acres had been planted the year previous to this with plants of the *succirubra* species of Chinchona purchased from Government. These had grown up into nice plants of over a foot in height, but in this gale were nearly all snapped over close to the ground. This was in the month of July, but as no rain fell during that nor the succeeding two months, I had to wait patiently till the month of October, or the setting in of the north-east monsoon, before beginning planting operations. This monsoon set in in due course and proved an excellent one for planting, so that I had no difficulty in putting out the 600,000 plants before the rains ceased.

After the work had been completed I began to consider whether a plantation of Chinchona could ever be raised over the whole area of the 500 acres that had been cleared of forest, and I came to the conclusion that it could not. The soil was excellent over the whole surface, and all other conditions were most favourable to the forming of a magnificent plantation. But the question of the wind had to be considered, and it was evident that save in the sheltered nooks it would be quite impossible to form a plantation of even stunted growth. The difference of elevation between the foot of the plantation and the top ridges was as much as 700 feet, and the wind striking these ridges where no sheltering belts had been left came down upon the plantation, sweeping everything before it. Had I been wise I would have relinquished charge of the plantation after the first planting had been completed, but I foolishly waited to see the effect of another monsoon on the plants I had just put out, hoping against hope that it might not prove so disastrous as the one I had just passed through. The planting

proved a very successful one, and before the following July the plants had attained an average height of 15 inches. The monsoon burst as usual about the end of June, the wind increasing in strength till about the 15th July, when it culminated in a terrific gale of three days, when it suddenly calmed and the sun came out as bright as ever. I had made it a point not to visit the estate during the whole time of the storm, but when it ceased I had a quiet walk round the plantation to view the damage which I knew quite well had been done. I had put the estimate of damage in my own mind at a pretty high figure, but the result of my walk proved I had not put it nearly high enough, as at least 400,000 out of the 600,000 plants put out had been snapped off by the ground and were blown into the ravines below and on the roads, where they lay in wreaths withering in the sun. The stem of the *succirubra* species of Chinchona is exceedingly brittle when in a young state, so that the plants were not wrung about and thus destroyed, but snapped clean off, and the land stripped and the year's work and expenditure nearly totally lost. I at once communicated with the proprietors of the property, giving it as my opinion that a plantation of Chinchona could not be produced over the whole area of the land till such time as some sort of shelter could be raised for the due protection of the plants, and offering my resignation. In this opinion they did not concur, and induced me to remain at my post, which I was sorry for ever afterwards.

Young plants were raised in abundance for three years in succession and the land regularly replanted, the plants as regularly meeting the same fate as those of the first planting. Attempts were made to grow belts of *Eucalyptus globulus* and *Acacia melanoxylon* to break the wind, but only with very partial success, the severe monsoon storms retarding their growth generally, so that the cultivation of Chinchona was eventually abandoned on the estate except in the sheltered nooks, which formed but a very small area in proportion to the whole land, so that here was a property all but totally ruined by too grasping a policy in the first instance, and by a total want of knowledge or ignoring of the peculiarities of the climate of the district, and as a monument of this false economy was left a few hundreds of acres of thorny scrub in place of the beautiful and picturesque Shola of former days. The exercise of a little forethought would have prevented all this. Had the forest clothing the ridges been simply left as a protection the lower portions of the land could have been cultivated in perfect shelter, and with every chance of success, but no cultivated plant, be it Tea, Coffee, or Chinchona, will ever thrive if planted in a position fully exposed to the heavy south-west monsoon blasts, which are stronger as the elevation is greater. In large blocks of forest extending for miles, as in the Wynaad, it is very difficult to say where the wind will strike after say 100 acres is felled; and frequently mistakes of a very serious nature are made, even when the greatest precaution is taken beforehand; but as regards smaller isolated patches, such as are found on the Nilgiris, the case is different, and with ordinary precaution no mistakes of this nature need occur. At the time I write of the *succirubra* species of Chinchona was alone planted on land under 6500 feet; above that elevation the officialis species with its hybrids were planted. Since those days the latter has so superseded the former in value of bark that estates of *succirubra* are at the present moment considered of little or no value, from the much smaller quantity of alkaloids found in the bark and the greater difficulty in their extraction. No one dreams of planting *succirubra* in these days, and existing estates of this species I believe are in some cases being replanted with Tea.

While living at Deva Shola I had the opportunity of witnessing the flowering of a low shrub, a species of *Strobilanthus*, but not the same as grew amongst the trees of the forest. It is a low evergreen shrub which covers the hills for miles, and is said to flower only once in seven years. It has a very beautiful blue flower, and when in full bloom the appearance of the hills is beyond description. After flowering and ripening its seed the plant dies, but springs again very readily from seed, so that after the death of the old plants the hills are soon clothed again. It has been said that it is from this flower that the Nilgiris get the name of the Blue Mountains, but this, of course, is only fanciful. Not far from Deva Shola, and at a slightly lower elevation, the wild Orange tree is to be found growing on the grass hills on the edges of the Sholas. It is a very beautiful object when covered with ripe fruit and flowers. I was much struck with its great beauty when I accidentally came upon it for the first time. There were many trees in small groups and dotted singly over the grass hills. The trees were rich both in green and ripe fruit of a large size, and the flowers were abundant. The grass was strewn with ripe fruit, and altogether the sight in the wild was a very beautiful and interesting one. On tasting the fruit I found them bitter beyond expression. Another spot in this locality deserves mention—viz., Mailoor, which is a village about three miles from Deva Shola, and possessing a very mild and delightful climate. A few yards from the village may be seen sculptured slabs of stone, which are involved in mystery, no one knowing who put them there, or why, enhancing the interest attached to them. Near by is a temple belonging to one of the hill tribes surrounded by splendid specimens of *Eleocarpus* trees, their wide-spreading branches affording a deep shade, which gives solemnity to the scene. The temple itself stands in the middle of a circle marked out with a rugged stone wall 3 or 4 feet in height. The temple is dedicated, it is supposed, to the Fire God of this particular tribe, as within the circle there is a small hollow in the ground, which is the scene of one of their religious ceremonies—namely, that of walking through fire. The hollow is filled with burning ashes, through which each devotee walks slowly and majestically; this rite is performed once a year. This



locality is extremely rich in Ferns; in addition to Tree Ferns in abundance there are numerous others, including *Adiantum caudatum*, *A. hispidulum*, *Davallia tenuifolia* in huge masses draping the branches, *Pteris geraniifolia*, *P. cretica*, and many others, whilst the trees are draped with such species as *Asplenium furcatum*, *Elaphoglossum conforme*, &c. *Lilium neilgherense* is also found in abundance in the neighbourhood. It is frequently seen growing out of the fissures of damp cliffs and rocks, and seems to like a good deal of moisture. As a rule it produces only a single flower on each stem, but I have frequently seen from two to three on a stem, and I believe as many as six blooms have been counted on one stem. It is a very beautiful plant in its wild state. It is now, I believe becoming very scarce owing to the ravages of collectors.

After building the house on the Deva Shola plantation, I laid out a small flower garden in front, planting it mostly with Verbenas and Petunias the first year, which at that time were all the plants I had available. I devoted a bed to each variety, and the result was startling and unexpected. After the north-east rains ceased the plants began to bloom, and for a whole year presented such an appearance as I never saw before produced by plants of the same kind. The beds during that time were simply a blaze of the brightest coloured flowers, and were the admiration of all who saw them. On the pillars of the verandah I had *Passiflora edulis*, which gave me fruit all the year round, *Bignonia*s and *Mandevilla suaveolens*, which yielded its sweet scented flowers abundantly at all seasons. By the way, I have seen this plant in the Botanical Gardens at Ootacamund which had found its way to the top of a large tree, covering the crown of its supporter with a wealth of its pure white blossoms, which is another proof of the mild nature of the climate. The above-named gardens are extremely interesting and are well managed, but I shall have more to say regarding them perhaps in my next paper.—PLANTER.

(To be continued.)



#### HARDY FRUIT GARDEN,

**LATE APPLES.**—Many err in gathering these too early, or before they either part readily from the trees or the seeds are brown. This is sometimes owing to those responsible following the time-honoured custom of clearing whole orchards or all the garden trees at about the same time. If there is no avoiding this practice it is advisable to commence gathering when the late sorts are fit, instead of being ruled by the earlier varieties. The former, if gathered and stored at the proper time, are by far the most valuable; whereas, if picked or dragged from the trees before they are fit for storing they rarely attain to perfection, the fruit keeping badly and shrivel prematurely. In the case of all garden trees or small orchards in proximity to the house or garden there is no excuse for too early gathering. With us it is now an almost daily habit of looking round all the trees. The Apples change rapidly, and those unfit to gather early in the week may be quite ready by the end of the week. Cox's Orange Pippin, one of the most valuable dessert sorts we have, were in some positions fit for gathering by the third week in September, others will be stored early in October. King of the Pippins, an earlier sort, and nearly as long keeping, ought in most backward localities to be yet on the trees. With us they ripen unevenly, and are gathered piecemeal. Blenheim Pippin will hold on till early in October, at which time Court of Wick, Adam's Pearmain, Margil, and Ribston Pippin promise to be ready for careful storage. Braddick's Nonpareil, one of the best winter varieties, we gather rather early, but Ross Nonpareil, Pearson's Plate, Rushock Pearmain, and Wyken Pippin are still far from being fit for storing, though the case may be different on warmer soils. The last to be gathered are Court-Pendu-Plat, Northern Spy, Scarlet Nonpareil, and Cornish Gilliflower. Golden Knob, a favourite Kentish Apple, ought to remain on the trees longer than any, and Sturmer Pippin must not hastily be gathered, or this valuable late sort will be of little real service, being tough and dry when gathered too soon. The foregoing remarks also apply to many of the later culinary varieties. Emperor Alexander, Golden Noble, Waltham Abbey Seedling, Cellini, Cox's Pomona, Hoary Morning, all may be gathered soon after the Codlin. Ecklinville, Flower of Kent, Lord Derby, Hollandbury, Kentish Pippin, and Tom Putt with us will be gathered at the end of September, these being followed by such later sorts as Tower of Glamis, Mère de Ménage, Beauty of Kent, Warner's King, Dumelow's Seedling, Lemon Pippin, Royal Somerset, and London Pippin. The last to be gathered and used will be the Alfriston, Betty Geeson, Reinette de Canada, Hanwell Souring, Hambleton Deux Ans, Winter Greening, and Norfolk Beefing.

Those who are fortunate in having large crops of good fruit may be in a dilemma as to where to stow it all. Ordinary kitchen Apples need not be stored thinly on dry shelves or floors; on the contrary, they keep better in every way when stored in good-sized heaps. Nor need these heaps be formed in a dry room. Out-houses and even a well-drained spot

in the open air are quite as suitable. In every case none but quite sound fruit should be stored, these being carefully handled and covered with mats or dry straw in order to exclude both cold winds and severe frosts. It is unwise to cover these heaps for several days after they are formed, unless it be to keep off rains or frost. Close musty sheds or disused Mushroom houses are unfit for the storage of Apples, the fruit in all such places soon becoming badly tainted. Straw and hay may be fresh and sweet for a time, but it soon becomes musty, and ought in no case to come into contact with dessert Apples. Clean boards, or, better still, boards covered with clean paper, drawers, and boxes, are much the best for the fruit to rest on or to be stored in from the first.

**LATE PEARS.**—There are few more reliable September than Beurré d'Amanlis, and it is especially good this season. It keeps badly, and should therefore be used quickly. By the end of September the large, distinct, and valuable Pitmaston Duchess will be available. This should be grown in different positions, gathered at intervals and tenderly handled, in which manner it is possible to secure a succession of delicious fruit till November. Fondante d'Automne is a good October Pear, and the ever-popular Louise Bonne of Jersey can seldom be kept after October. Marie Louise d'Ucele is quite distinct from the good old Marie Louise, and does not keep so well. The last named and also the only slightly inferior Doyenné du Comice ought to be gathered at intervals in order to prolong their season as long as possible, no other sorts we have being relished when these are in season. Both may be frequently kept as late as the middle of November. Maréchal de Cour is in season about the same time as Marie Louise, while the rather second-rate Beurré Diez keeps at least a fortnight longer. Care should be taken not to gather the Crassannes too early, or shrivelling and dryness may be the consequence. The best of them, Althorp Crassanne, is in season from October to December. Thompson's and Van Mons Léon Leclere are both in season late in October, and frequently keep to the middle of November. Huyshe's Prince Consort and Princess of Wales must not be dragged from the trees, both of these with us being especially liable to shrivel. Hacon's Incomparable is good through November and December, Napoleon being in season about the same time. The delicious Winter Nelis is rarely fit to gather before October, and should keep good from November to February. Chaumontel with us usually hangs late. Beurré Bachelier must be watched closely or fine fruit may fall and be spoilt. It is available during December, and is a good Pear. General Todleben must also be watched closely both as regards the time to gather and when to eat it; it hangs rather late with us, and seldom keeps good through November. Glou Morceau ought to be one of the last to be gathered. Leave both this, Easter Beurré, Beurré Ranee, Bergamotte Esperen, Beurré d'Aremberg, Jean de Witte, Ne Plus Meuris, and Olivier de Serres on the trees till such times as they part freely when gently raised. Most of them are very frequently gathered too soon, those in charge, knowing their value as good late keepers, being very anxious to get them safely stored. If birds are troublesome net over the trees. All the Pears should be stowed either in drawers or on shelves, as much as possible in single layers, with their stalks uppermost. Avoid keeping the room very hot, and guard against either low temperatures or cold draughts.

**ROOT-PRUNING FRUIT TREES.**—In most districts the work of partially lifting and root-pruning may safely be commenced. It is better done now for several reasons, among these being the fact that there will yet be time for fresh fibres to be formed before the leaves fall, and besides, the work, owing to the comparative dryness of the ground, can better be carried out in September and October. Trees that persist in growing vigorously without fruiting, if given a check at the roots, may soon be rendered fruitful, probably during the next season; while any that are rooting too deeply, and as a consequence are become sickly and of little real service, may also be improved or renovated by lifting. Those planted against walls, as well as those in the open, are benefited by partial lifting. To wholly lift large trees might kill them, but if one-half of the roots are searched out, shortened with a sharp knife, and relaid in good fresh compost this autumn, and the remainder next year, the process will be both safe and effective. The first trench should be opened at least 6 feet distant from the stem of a large tree, and about 4 feet from younger or smaller trees. Usually some of the most deeply running roots are immediately under the stem, hence the necessity for gradually undermining till these are reached and cut through. If plenty of turfy loam is available little else need be added to the border, though we find the roots delight in plenty of burnt garden refuse when this is freely mixed with the compost. Transplanting ought not to be attempted yet.

#### FRUIT FORCING.

**STRAWBERRIES IN POTS.**—The autumn fruiters, if any are grown, should be encouraged with weak guano water or sulphate of ammonia, 1 oz. of the first and half ounce of the latter to a gallon of water, and in the case of heavy rains and the fruit approaching ripening the plants should be placed in frames with abundant ventilation, which will improve the quality and colour considerably. The varieties most suitable for autumn fruiting are La Grosse Suerée, Sir Harry, and Vicomtesse Hericart de Thury. Plants that have been forced in spring, shaken out, repotted, and grown on are excellent for autumn and early winter fruiting, or if planted out and duly attended to they can be lifted at the end of September, potted, and placed in a cold frame. Any autumn fruiters not required to fruit for some time yet may be retarded by placing them on a north border.

A loose surface for Strawberries in pots prevents the soil leaving the sides of the pots, and admits of the water passing equally through

the ball and moistening it thoroughly. A little dried horse droppings or cowdung applied to the surface will keep all right there. Remove all runners as they appear, also weeds, and do not allow the plants to suffer through insufficient supplies of water. The plants should have plenty of space for the full exposure of the foliage to light and air, which is essential to sturdy growth and plump well-developed crowns.

**CUCUMBERS.**—The autumn fruited must have careful attention, affording copious supplies of liquid manure, removing superfluous male blossoms and tendrils, avoiding overcropping, and not allowing the fruit to hang too long. The syringe should only be employed at closing time on bright afternoons. Earth up the roots as the plants advance in growth from time to time. Pinch out the growing point one or two joints beyond the fruit, examining the plants at least once a week for that purpose, retaining no more foliage than can be fully exposed to light. All water must be given at the same temperature as that of the roots. Pot the plants from seed sown at the beginning of the month for winter fruiting directly they are large enough, plunging the pots in bottom heat until the plants are established, then raise them near the glass, maintaining a temperature of 70° at night, 75° by day, with an advance from sun heat of 10° to 15°. The fermenting materials, if such are used for bottom heat, must be in preparation for the formation of the beds in due time. For producing a good supply of fruit in late January or early February seed should be sown at the beginning of October.

Plants in dung-heated frames or pits must have the linings renewed as required, the foliage being kept rather thin, the shoots well stopped to a joint beyond the show of fruit, and no more water should be given than to secure healthy moisture for the roots, placing mats over the lights on cold nights.

**PINES.**—To maintain the sturdy healthful appearance of young growing stock free ventilation is necessary, maintaining the bottom heat about the roots at 80°, watering the plants whenever they require it, employing weak liquid manure occasionally, and avoiding the use of the syringe too frequently; merely sprinkling the paths, &c., morning and evening daily will suffice. Fire heat must be resorted to to maintain a night temperature of 60° to 65°. Newly potted plants should have a bottom heat of 90° to 95°, with a view to the roots speedily penetrating the soil. Recently started suckers should, as soon as roots are plentiful, be raised near the glass, it being essential that those intended to be wintered in small pots be brought on gradually. Fruiting plants should have a night temperature of 70°; 80° to 90° during the day, closing at 85°.

When the suckers started this autumn are rooted pot them without delay, draining the pots well. Employ the fibry part of turfy loam, and do not tear it up too fine, but use it in lumps proportionate to the size of the pots. The strongest plants may be transferred to the fruiting pots at once, the size of the pots being proportionate to the robustness of the varieties. Jamaica do well in 9 or 10-inch pots, Queen in 10 or 11-inch pots, Smooth-leaved Cayennes and similar varieties in 11 to 12-inch pots, and Providence in 12 to 13-inch pots, which will afford fruit of the largest size. Where smaller plants and fruit are the objects aimed at, pots an inch or two less in diameter will answer. The plants not of a size fit for transferring to the largest pots can be shifted into 8-inch pots, in which they may be kept until spring and then be transferred to a larger size.

#### PLANT HOUSES.

**Gesneras.**—These should occupy a shelf close to the glass where the temperature at night does not fall below 65°. The plants should now be strong with large leaves, and the pots moderately full of roots. A little artificial manure applied to the surface of the soil at intervals of a fortnight will prove beneficial, or clean soft water in a weak state may be given every time water is needed. The last is perhaps the best stimulant that can be given to these plants, for it brings out the beautiful markings of their foliage. Water carefully, but do not allow the plants to suffer by an insufficient supply. At the same time be careful that water does not lodge upon their foliage, which will turn it brown, and thus destroy their beautiful appearance.

**Tydas.**—Many of these grown for autumn and early winter flowering will be showing signs of flowering. These must be brought forward, for no advantage is gained by attempting to retard them. They will do under the same treatment and conditions as Gesneras. T. Madame Heine for flowering during February and March must not be grown too warm, or they will soon become tall. They should be grown close to the glass where the temperature does not exceed 60°, and where a circulation of air can be provided on fine bright days. Some of the latest of these may now be transferred into 4-inch and 5-inch pots, and will form a capital succession to those that are well established in those sizes. Be careful not to syringe the foliage of these plants.

**Gloxinias.**—Late in the year the flowers of these plants are equally as useful as they are early in the season. During the dull days of November and December their bright yet delicate flowers are very effective in small or shallow vases associated with *Adiantum cuneatum*. Plants now in small pots, whether seedlings or raised from leaves, may be placed into 4-inch pots and grown on a shelf close to the glass where a temperature of 60° to 65° is kept at night. Under these conditions they will grow rapidly and soon commence pushing up their flowers. Old plants that have thoroughly gone to rest may have the old soil shaken from them and then stored in boxes amongst sand until they are wanted. For the present they will do in any cool dry shed. Those that

have been flowering recently must not be hurried to rest. Water them carefully and judiciously until their foliage naturally dies away, and afterwards keep them dry.

**Achimenes.**—The latest that were raised from cuttings will be getting past their best, and may be thrown out provided the old stool plants have been reserved for next year's stock of plants. Ripen these gradually by diminishing the supply of water. From this time they will do very well on a shelf at the back of a late vinery where the Grapes are about ripe. The moderately dry air of this structure will suit them exactly.

**Eucharis amazonica.**—If the supply of blooms from these is required over a long period during the autumn and winter, those that have completed their growth may be removed to cooler quarters for a few weeks to rest. Do not remove too many plants at one time; select a few of the most promising, and a few more at intervals of ten days or a fortnight according to the time they complete their growth. The rest they enjoy in cool quarters can either be of short or long duration according to circumstances. Those that have first flowered must be pushed into growth, and with good management should flower again in January. With care and judgment in pushing plants forward and retarding others there is no difficulty in having *Eucharises* during the whole of the year, though intervals of a week or fortnight may elapse without blooms even under the best of management, as it is very difficult to time the plants to a few days. Before the plants are removed to cooler quarters allow them to become somewhat drier at their roots, and keep them in this condition until they are returned to the stove. At the same time they must not be allowed to flag or suffer by an insufficient supply of water at their roots.

## THE BEE-KEEPER.

### PRACTICAL BEE-KEEPING.—No. 19.

**SWARMS**, it is well known, can be taken artificially from either skeps or frame hives, but it is rather more difficult in some cases to take them from the former class of hives than the latter; in fact, some bee-keepers of considerable experience seem to consider it hazardous to attempt to take an artificial swarm from a skep unless the conditions are more than usually favourable. It can hardly be denied that unless considerable care is exercised a great injury may be done to a stock. It is a dangerous experiment for anyone who does not understand the necessary conditions to which attention must be paid if success is to attend the attempt to try to take an artificial swarm. For the benefit of those who prefer to take a forced increase rather than to risk the possible loss of a swarm by its unexpected issue when no one is at hand to hive it, an attempt shall be made to show how and when an artificial swarm may most easily be taken.

Driven bees must be placed on their old stand or removed to a distance of not less than two miles. An artificial swarm cannot be placed in any position the bee-keeper may desire, like a natural swarm must hold a certain position, according to the method of taking the swarm adopted, and no other. This is the great drawback to taking swarms artificially, and although there are certain ways of overcoming the difficulty still the loss of time to the bees and the trouble laid upon the bee-keeper in effecting the object are scarcely commensurate with the gain achieved in its attainment except under unusual circumstances. These methods must be reserved for future discussion.

Again, a swarm must never be taken from any stock until it is evident that there is a large surplus population. From ten to fifteen days after a stock is ready to work in supers is a very good time to take a swarm, but it is far wiser to delay for a few days later than to depopulate a hive before the population has become excessive. When a stock is crowded with bees and the weather is mild and favourable, the bee-keeper may proceed in the middle of a fine sunny day to drive the bees from the stock until at least one-half of the whole population has left the old

home. If possible the queen should be seen, because it is absolutely necessary that she should go with the swarm and not remain in the old stock. If one-half of the bees have been driven into a new hive and the queen has not been seen, the driven bees may be placed 3 or 4 feet to the right of the old stand and the stock 3 or 4 feet to the left. In a very few minutes by the manner of the bees we can ascertain which hive contains the queen. If the swarm seems to settle and become contented it may be concluded that the queen is there, but if the bees of the swarm run anxiously about and do not seem inclined to settle and stay in their new home the queen is still in the old stock. To that consequently the whole swarm will by degrees return unless we again drive the stock until the queen goes with the driven bees. When the queen goes with the swarm the manipulation is ended, and the swarm is successfully taken. If owing to this second driving the swarm is too large, and the stock is consequently too much depopulated, part of the swarm may be returned, or the stock may be placed nearer to the old stand than the swarm, and it will accordingly draw away a portion of the flying bees from the swarm. Again, if the swarm is not large enough and too many bees remain in the stock the swarm may be placed nearer to the old stand, so that some of the bees of the stock may desert and go to the swarm. In every case it is better to err on the safe side and to take half a swarm rather than a whole one, unless we have absolute confidence that sufficient bees will remain in the stock to feed and attend to the brood, and if necessary to raise a queen. In all probability no queen cells will be found in the stock. If this is the case no cast must be expected until from the fourteenth to the seventeenth day after taking the swarm. A cast will, however, be altogether avoided by giving either a ripe queen cell or young queen—as in the case of a natural swarm—and thus bringing up the stock to its full strength again in a much shorter time than would otherwise be possible if the bees were left to raise a young queen according to their own instinct.

In taking an artificial swarm from a bar-frame hive there is much less trouble in ordinary cases, because instead of driving the bees in order to find the queen it is only necessary to remove each frame singly until the queen is found. Then take the frame just as it is with the queen upon it, and place it in a new hive fitted with frames filled with foundation, or at any rate having starters, and close up to both the stock from which the queen and frame have been stolen, and also the hive into which such queen and frame have been inserted. The latter hive being put in the exact position previously occupied by the frames, and the frames being placed in a new position some distance from the old stand now occupied by the swarm, and the work is finished. Many bees will be flying, and will return direct to the old spot, and at once begin to work out the comb. Many will desert the old stock and join the new colony headed by their old queen. If a young queen or a ripe cell is given to the old stock no cast will issue, and there will be a shorter break in the brood-rearing, both swarm and stock will rapidly increase in strength, and by giving each a little syrup every day a perfect success will follow this exceedingly simple manipulation.

There are many modifications of this method. In the case of a "Stewarton hive," if the queen is seen in one of the boxes, by removing this box and afterwards proceeding in the manner above pointed out, an artificial swarm is at once taken most easily. In "The Apiary," an instance is given of a queen being seen in a glass super,

and the ease with which an artificial swarm was therefore at once achieved. What, then, it may be asked, are the conditions which ensure success? They are:—

- 1, A large surplus population.
- 2, Fine warm sunny weather.
- 3, Care in placing the swarm and stock.
- 4, The presence of the old queen with the swarm.

Everyone will see at once that unless the old queen goes with the swarm the bees will not remain, because unless the bee-keeper gives them a queen they must become extinct and would construct nothing but drone comb. The old hive may safely be deprived of its queen, because the presence of eggs and brood in its earlier stages gives the bees power, if necessary, to raise a successor to save them from the extinction which must, under less favourable circumstances, most surely overtake them. Stocks strong enough to yield a swarm will almost invariably contain either flying drones or at least capped drone cells: but if young queens have to be fertilised, care must be taken to have drones flying freely in fine weather by the time when the young queens will be desirous of meeting them.

Considerable experience and judgment are necessary in a bee-keeper before he is able to decide when a stock can afford a swarm, but the advantage of taking these artificial swarms is so great that few now care to allow natural swarms to issue. A change in the weather may delay a natural swarm from issuing for weeks, and in every case there is considerable delay and loss of time for some days previous to the date of issue. Again, the bee-keeper generally has some other business to attend to, and it is often utterly impossible to have the apiary so closely watched as to preclude the chance of losing a proportion of these swarms issuing when they are not expected, and when there is nobody near to hive them.

Many stocks are ruined by the too eager bee-keeper taking a large swarm from them before they are able even to yield a small one. It is far better to have one good strong stock than a weakling swarm and a depopulated stock. If there is any doubt as to the ability of the stock to yield a good sized swarm, it is better policy either to delay taking the increase until such stock is crowded with bees, brood, and honey to such an extent as to almost drive them to send out a swarm of their own accord, or to take a portion of a swarm from two or more stocks instead of calling upon one stock only to supply the bees necessary for a strong swarm and for rearing the brood in the old stock. In every case it is good management to feed both stock and swarm for a few days, and if wet and unfavourable weather intervenes it is absolutely necessary. The stock will generally only require a small quantity, but the swarm may be more liberally fed, but sufficient only should be given to make the bees to build their combs and to live upon; otherwise, if the practice of "extracting" from "brood combs" is exercised the honey can hardly be guaranteed "pure and unadulterated," even if the practice of extracting from "brood combs" does not itself contaminate the honey. With proper care and attention an artificial swarm is a certain success, but the fact still remains that very many bee-keepers are unable to take a good swarm without ruining the stock. The cause of this non-success is variable, and may generally most easily be discovered. If attention is paid to what may be called the elements of success there need be no apprehension as to the result of the manipulation, but a sanguine expectation of final success. If the bee-keeper cannot detect the elements of success, it will be better to call in a friend who has sufficient



knowledge and experience rather than endanger the prospects of a year by the indiscretion of an hour.—**FELIX.**

### TRADE CATALOGUES RECEIVED.

Webb & Sons, Wordsley, Stourbridge.—*Catalogue of Selected Seed Corn, 1887-8.*

William Rumsey, Waltham Cross, N.—*Catalogue of Roses, 1887-8.*



All correspondence should be directed either to "THE EDITOR" or to "THE PUBLISHER." Letters addressed to Dr. Hogg or members of the staff often remain unopened unavoidably. We request that no one will write privately to any of our correspondents, as doing so subjects them to unjustifiable trouble and expense.

Correspondents should not mix up on the same sheet questions relating to Gardening and those on Bee subjects, and should never send more than two or three questions at once. All articles intended for insertion should be written on one side of the paper only. We cannot reply to questions through the post, and we do not undertake to return rejected communications.

**LATE INQUIRIES.**—It is necessary to again remind correspondents that letters arriving on **WEDNESDAY MORNING** cannot be answered in the "next issue," which is then far advanced for press.

**Address (R. N., Notts).**—You will probably be able to obtain what you require from Spratts Patent, Limited, Henry Street, Bermondsey, London, S.E.

**Wasp Destroyer (Several Inquirers).**—We do not know where it can be obtained, and do not think it is advertised.

**Plums for Wall (Rus in Urbe).**—For the south-east aspect Green Gage, and for the south-west Jefferson or Coe's Golden Drop.

**Mushroom (G.C.).**—Yes, it is the common Mushroom, *Agaricus campestris*. Mushrooms often appear in particular places such as you describe, just as they come in certain portions of a field for several years in succession.

**Plum Mirabelle Petite (H. Osman).**—Your Plum has had various names, such as Mirabelle Jaune, Mirabelle de Vienne, &c., but its accepted title is that given above. It is a valuable Plum for preserving purposes, and though small is usually very prolific, though we know trees in warm Sussex gardens that will not fruit. You do not mention whether your trees are free or not.

**Compost for Surface-dressing Vines (Doctor).**—The compost you describe will be a very suitable one, being thoroughly incorporated, and applied not more than 3 or 4 inches thick. It is very desirable whilst about work of the kind proposed to remove the soil from amongst the roots as far as practicable and supply fresh, making the whole tolerably firm, to effect which the soil should be in good working order.

**Dividing Azaleas (Idem).**—Without seeing the plants we are unable to state whether they can be divided or not, but if they can have an equal share of roots they may be so treated. It is necessary, however, that the plants have good roots, otherwise we do not think the proposed division safe. We have lifted many very large plants for forcing, and always found it best to keep the ball entire. The plants could be placed in tubs if too large for pots.

**Cut Flowers for Market (H. J. S.).**—There is such severe competition now that those well skilled in the trade have a difficulty in realising remunerative prices, and there are so many private establishments disposing of surplus produce that the markets, and especially Covent Garden, are supplied at low prices. An amateur with nothing but cold frames could not safely enter the business. There is no small book devoted to the subject. The prices quoted in our columns weekly are the retail prices.

**Planting Vines (J. W. H.).**—Provided the leaves have not fallen it would be advisable to plant the Vines from the pot now, spreading out the roots after disentangling them, and by shading the Vines for a few days they will soon become established in their fresh quarters. If the leaves are off defer planting until they have made an inch or two of fresh growth. They should be placed in the house they are to be planted in when the house is started.

**Indiarubber Plant Leaves Decayed (A. F., Purfleet).**—The leaf is not diseased so far as we can detect, but is decayed from the point upward, and this is common to the plant when grown in too cold and moist an atmosphere. The only remedy we can suggest is to keep water from the foliage either by syringing or drip from the roof, and maintain a more genial condition of the atmosphere. Sponge the leaves when necessary with clear water only, being careful not to injure them, or they will certainly decay.

**Fruit Trees for South Wall (W. M.).**—A south wall is suitable for Apricots, Peaches, and Nectarines, Plums, Pears, and Cherries. The choicest of those are:—Apricots: Peach and Moor Park. Peaches: Hale's Early, Stirling Castle, and Barrington. Nectarines: Lord Napier, Pine Apple, and Victoria. Plums: Green Gage, Jefferson, and Coe's Golden Drop. Pears: Jargonelle, Beurré Superfin, Marie Louise, Pitmaston Duchess, Doyenné du Comice, Durondeau, and Josephine de Malines. Cherries: Early Rivers, May Duke, and Governor Wood.

**Affiliation with the Royal Horticultural Society (J. Sargeant).**—The Council receive provincial horticultural and floral societies into association upon an annual subscription of five guineas. They offer them the following privileges:—One silver Knightian medal, one silver Banksian medal, one bronze Knightian medal, one bronze Banksian medal—to be given as prizes at the shows of the provincial society—one member's ticket for the Secretary, and twelve single tickets, admitting the bearer to any one meeting or show of the Royal Horticultural Society.

**Cabbage Grub (G. J. B.).**—Your Cabbages have been attacked by the larva of the great yellow underwing moth, *Triphaena pronuba*, which occurs frequently at the roots of Lettuces also, and on various plants in the kitchen garden. The eggs are deposited during July by the parent moths, which are conspicuous and should be captured whenever seen. Their progeny feed from the autumn until spring, when they enter the chrysalis stage. Amongst the remedies that have been approved is the application of soot or soot mixed with lime to the stocks of the plants, also ashes or sand moistened with petroleum, and watering with soapsuds, tobacco water, or the decoction of quassia.

**Making a Horseradish Bed (A Subscriber).**—It is necessary that the ground be trenched and well manured. If there be any waste refuse from the garden partially reduced it may be used advantageously, especially if it contain a good proportion of charred refuse; indeed, the finest Horseradish we have seen was grown on a bed formed of a rubbish heap, the woody portions being used for charring the coarser portions. The value of the rubbish heap for Horseradish was no doubt due to the potash. Choose long small young portions of the roots for sets, the longer the better, and plant in rows 2 feet apart and 1 foot asunder in the rows, with the roots as straight as practicable and the crown covered with soil. Long small pieces of roots make good sets, cutting them into lengths of about 12 to 15 inches. They should be planted upright, taking out a trench, and so that the top is buried about an inch. Good roots with crowns will give good suitable roots for lifting in a year, and the smaller ones without crowns in two from the time of planting.

**Placing Slates or Stone under Fruit Trees (Idem).**—It is a good plan, as it prevents the roots from striking down, causing them to extend laterally. They should be placed 2 feet from the surface. Royal George and Noblesse are excellent Peaches. Three good Nectarines are Lord Napier, Pine Apple, and Victoria.

**Trees for Screen on the Seacoast (H. G. A.).**—There is no evergreen tree so suitable as *Pinus austriaca*, and it is equally serviceable inland, thriving in the bleakest situations and at high altitudes. We should plant a good width of *Pinus austriaca* near the sea, then an inner one of Sycamore, having Holly for undergrowth, which should be planted so that the Sycamores will ultimately be 24 feet apart every way, and the Hollies 12 feet, planting the Hollies at those distances apart in the first instance, and the Sycamores 4 feet. Inside you can have most kinds of deciduous trees and shrubs, also evergreens, Conifers doing remarkably well.

**Apples for Orchard (Idem).**—The early Apples are as eligible for standards as the late varieties. Dessert Apples: Irish Peach, Kerry Pippin, Cox's Orange Pippin, Scarlet Nonpareil, Court of Wick, Scarlet Golden Pippin, Reinette de Canada, and Allen's Everlasting. Kitchen: Yorkshire Beauty, Duchess of Oidenburgh, Worcester Pearmain, Cellini, Small's Admirable, Dutch Mignonne, Dumelow's Seedling, Northern Greening. If you want more dessert varieties have Mr. G'ardstone, Quarrenden (Devonshire), Margil, The Queen, Duke of Devonshire, Northern Spy, Gipsy King, Adam's Pearmain, Nonpareil White, and Sturmer Pippin; or of kitchen varieties, Lord Suffield, Ecklinville, Blenheim Pippin, Nelson Codlin, Peasgood's Nonesuch, Bramley's Seedling, Tower of Glamis, Prince Albert, Bedfordshire Foundling, and Gooseberry Apple.

**Millipedes in Carnation Bed (M. J. C.).**—The caterpillar is a millipede (*Julus pulchellus*), which is found plentifully where there is decayed vegetable matter, and is injurious, as it also feeds on live plants. Some Carrot and Potato baits inserted in the soil will entice them, and by examining them frequently the millipedes may be destroyed.

**Pears Decaying at the Core (Idem).**—It is not unusual for extra fine examples of some kinds to decay at the core before ripening, and is probably due to a deficiency of moisture at the roots during the swelling period, the soil not being firm and moisture-holding. The only remedy we can suggest is to mulch over the roots and keep them well supplied with water in any dry periods that may occur during the swelling period, especially after midsummer.

**Dahlias—Seedling Chrysanthemums (H. E., Jersey).**—The Dahlia blooms had suffered so much in transit through the post that their florets had all fallen, and it was quite impossible to determine whether they are distinct or not, but their colours did not indicate anything remarkable. We shall be pleased to see blooms of your seedling Chrysanthemums when they expand.

**Culture of Liliun Browni (W. Hurtfield).**—This fine Lily may be grown to perfection either in the open ground or in pots in a mixture of roughly chopped peat and yellow loam in equal parts, to which give a liberal addition of sharp sand or grit. Being still scarce it is deserving of special attention. If charcoal is to be had mix it liberally with the soil. It is perfectly hardy, but if planted in the open ground, ensure a perfectly drained position, and mulch annually with leaf soil. Under pot culture plant its bulbs (*i.e.*, flowering ones) in 7-inch pots, and let the apex be about 3 inches from the surface; this potting should be done at once. Repotting ought to have been done six weeks ago, as it is one of the early flowering species. Root action recommences in proportion. The pot plants should be

placed in a cold frame and covered with 6 inches of coal ashes or cocoa-nut fibre, giving one slight watering before covering, and in the case of fresh imported bulbs which will be minus roots, do not water at all till the new flower spike may be seen protruding through the covering.

**Names of Fruits.**—The names and addresses of senders of fruit to be named must in all cases be enclosed with the specimens, whether letters referring to the fruit are sent by post or not. The names are not necessarily required for publication, initials sufficing for that. Only six specimens can be named at once, and beyond that number cannot be preserved. (*H. Heath*).—1, Souvenir du Congrès; 2, Gillogil; 3, British Queen's Apple, one of the ornamental Crabs. (*G. N.*)—1, Warner's King; 2 and 3, Flower of Kent; 4, Lord Derby; 5, Cockle's Pippin; 6, Bess Pool. (*H. Hewat Craw*).—Nos. 1 and 2, Grenadier; 3, Not known; 4, Not known; 5, Pearson's Plate; 6, Not known. (*F. Jellico*).—Both Apples are Lord Suffield. (*G. W. Boothby*).—Your seedling is not good enough to be propagated. (*J. Woods*).—1, Fondante d'Automne; 2, Not known; 3, Doyenné du Comice; 4, Deux Sœurs; 5, Leon Leclerc de Laval; 6, Suffolk Thorn. (*John Melville*).—1, Devonshire Queen; 2, Not known.

**Names of Plants.**—We only undertake to name species of plants, not varieties that have originated from seed and termed florists' flowers. Flowering specimens are necessary of flowering plants, and Fern fronds should bear spores. Specimens should arrive in a fresh state in firm boxes. Slightly damp moss or soft green leaves form the best packing, dry cotton wool the worst. Not more than six specimens can be named at once. (*Park Hill*, and *Bob*).—*Viburnum Opulus*, the Guelder Rose. (*G. C.*)—Varieties of *Impatiens Noli-me-tangere*.

COVENT GARDEN MARKET.—SEPTEMBER 28TH.

HEAVY supplies of Cobs reaching us, causing prices to fall. No change otherwise.

		s. d.		s. d.	
Apples, ½ sieve..	1 6 to 3 6	Oranges, per 100	6 0 to 12 0		
Nova Scotia and		Peaches, dozen	2 0	6 0	
Canada barrel	0 0	Pears, dozen	1 0	1 6	
Cherries, ½ sieve	0 0	Pine Apples, English,			
Cobs, 100 lbs.	45 0	per lb.	1 6	0 0	
Figs, dozen	0 3	Plums, ½ sieve	1 6	2 6	
Grapes, per lb.	0 6	St. Michael Pines, each	3 0	6 0	
Lemons, case	10 0	Strawberries, per lb.	0 0	0 0	
Melon, each	0 6				

VEGETABLES.

		s. d.		s. d.	
Artichokes, dozen	1 0 to 2 0	Lettuce, dozen	0 9 to 0 0		
Asparagus, bundle	0 0	Mushrooms, punnet	0 6	1 0	
Beans, Kidney, per lb.	0 3	Mustard and Cress, punt.	0 2	0 6	
Beet, Red, dozen	1 0	Onions, bunch	0 3	0 6	
Broccoli, bundle	0 0	Parsley, dozen bunches	2 0	3 0	
Brussels Sprouts, ½ sieve	0 0	Parsnips, dozen	1 0	0 0	
Cabbage, dozen	1 6	Potatoes, per cwt.	4 0	5 0	
Capicums, per 100	1 6	Kidney, per owt.	4 0	0 0	
Carrots, bunch	0 4	Rhubarb, bundle	0 2	0 0	
Cauliflowers, dozen	3 0	Salsafy, bundle	1 0	1 6	
Celery, bundle	1 6	Scorzoner, bundle	1 6	0 0	
Coleworts, doz. bunches	2 0	Seakale, basket	0 0	0 0	
Cucumbers, each	0 4	Shallots, per lb.	0 3	0 0	
Endive, dozen	1 0	Spinach, bushel	3 0	4 0	
Herbs, bunch	0 2	Tomatoes, per lb.	0 4	0 6	
Leeks, bunch	0 3	Turnips, bunch	0 4	0 6	

PLANTS IN POTS.

		s. d.		s. d.	
Aralia Sieboldi, dozen	6 0 to 12 0	Fuchsia, dozen	3 0 to 9 0		
Arbor vitae (golden), dozen	6 0	Geranium (Ivy), dozen	0 0	0 0	
(common), dozen	0 0	Tricolor, dozen	0 0	0 0	
Asters, dozen pots	3 0	Gladiolus	4 0	6 0	
Azalea, dozen	0 0	Hydreaea, dozen	9 0	12 0	
Begonias, dozen	4 0	Lilies Valley, dozen	0 0	0 0	
Capicums, dozen	6 0	Lilium lancifolium, doz.	12 0	18 0	
Cineraria, dozen	0 0	longiflorum, doz.	0 0	0 0	
Creeper Jenny, dozen	0 0	Lobelia, dozen	0 0	0 0	
Dracena terminalis, doz.	30 0	Marguerite Daisy, dozen	6 0	12 0	
viridis, dozen	12 0	Mignonette, dozen	3 0	6 0	
Erica, various, dozen	9 0	Mnsk, dozen	0 0	0 0	
Eunonymus, in var., dozen	6 0	Myrtles, dozen	6 0	12 0	
Evergreens, in var., dozen	6 0	Palms, in var., each	2 6	21	
Ferns, in variety, dozen	4 0	Pelargoniums, dozen	6 0	12 0	
Ficus elastica, each	1 6	scarlet, doz.	3 0	9 0	
Foliage Plants, var., each	2 0	Spiraea, dozen	0 0	0 0	

CUT FLOWERS.

		s. d.		s. d.	
Abutilons, 12 bunches	2 0 to 4 0	Lilies, White, 12 bunches	0 0 to 0 0		
Anemones, 12 bunches	0 0	Orange, 12 bunches	0 0	0 0	
Arum Lilies, 12 blooms	3 0	Marguerites, 12 bunches	2 0	6 0	
Asters, 12 bunches	2 0	Mignonette, 12 bunches	1 0	3 0	
French, bunch	1 6	Myosotis, 12 bunches	1 6	3 0	
Bouvardias, bunch	0 6	Narciss, 12 bunches	0 0	0 0	
Camellias, blooms	0 0	White, English, bh.	0 0	0 0	
Carnations, 12 blooms	1 0	Pansies, 12 bunches	0 0	0 0	
12 bunches	4 0	Peas, Sweet, 12 bunches	1 6	3 0	
Cornflower, 12 bunches	1 6	Pelargoniums, 12 trusses	0 9	1 0	
Dahlia, 12 bunches	2 0	scarlet, 12 trusses	0 3	0 6	
Daisies, 12 bunches	2 0	Pinks, White, 12 bunches	0 0	0 0	
Encharis, dozen	2 0	various, 12 bunch	2 0	4 0	
Gardenias, 12 blooms	2 0	Poinsettia, 12 blooms	0 0	0 0	
Gladiolus, 12 sprays	1 0	Primula (single), bunch	0 0	0 0	
Hyalanthus, Roman, 12		(double), bunch	0 9	1 0	
sprays	0 0	Polyanthus, 12 bunches	0 0	0 0	
Iris, 12 bunches	0 0	Ranunculus, 12 bunches	0 0	0 0	
Lapageria, white, 12		Roses, 12 bunches	2 0	6 0	
blooms	1 6	(indoor), dozen	0 9	1 0	
Lapageria, coloured, 12		Tea, dozen	1 6	3 0	
blooms	1 0	red, dozen	0 0	0 0	
Lilac (white), French,		de Moiss, 12 bunches	0 0	0 0	
bunch	0 0	Stephanotis, 12 sprays	2 6	4 0	
Lilium longiflorum, 12		Tropeolum, 12 bunches	0 0	0 0	
blooms	2 0	Tuberose, 12 blooms	0 6	1 0	
Lilium lancifolium, 12		Tulips, dozen blooms	0 0	0 0	
blooms	0 6	Violets, 12 bunches	1 0	1 6	



MICHAELMAS.

MICHAELMAS marks the ending and beginning of so many important matters in agriculture that we may usefully direct special attention to some of them now. It is well also to consider the work of the past twelve months, to weigh well the cause of success or failure, in view of applying the teachings of experience to the improvement of our practice in the future. Certainly there never was a time when forethought, caution, and prudence were more called for. The tendency of prices for most farm produce is still downwards, and general expression is given to a wish to know the worst, or to know that we have reached so low a level that some recovery in value is possible.

The favourable weather for sowing Wheat last autumn might well have been taken for a good omen of a successful crop, for we certainly have harvested a Wheat crop of great abundance and high quality, but the market for new Wheat has opened at such low prices that the bulk of the crop will assuredly be withheld from sale for the present. Yet there are many heavy land and mixed soil farms where the crop will range from the high yield of 5 to 6 quarters an acre, with a proportionate bulk of straw, so that even at the low rate of 30s. per quarter there would be a return of from £7 to £9 per acre for grain alone. If to this we add from 2 to 3 tons of straw per acre, we can hardly admit that such Wheat is an unprofitable crop this year. But alas! even upon heavy land there has been much Wheat altogether inferior in both grain and straw. We have upon our writing table two bunches of ears of white-chaff Red Wheat, One is from one of the farms we have in hand, the ears are nearly 4 inches long and stout in proportion, the grains being four set in width; the other is from the farm of an outgoing tenant, and the ears are so small that several of them are not a third of the size of those from our farm, and the grains only two set wide. These samples of Wheat may fairly be taken as examples of results under good and bad cultivation. We know them to be so, and we regret to add that the farm from which the inferior sample was taken comes upon our hands this Michaelmas. In addition to its poverty-stricken condition much of it is so foul that we shall have to fallow it in next season in order to eradicate the couch grass and Thistles with which it is infested. It will be our aim to render this farm clean and fertile as speedily as possible, and experience tells us that it will eventually prove more profitable to fallow than to attempt cropping it next season.

Now the farmer who is leaving this farm is loud in his complaints of low prices and losses in farming, and yet it is clear that he is to blame for many, if not most, of his losses. If after three consecutive hot dry summers such as we have now had farm land is not clean we may well despair of its ever being so. No matter how low prices are, it cannot answer to halt cultivate the land. No farmer deserves to have his rent lowered who suffers weeds to steal the fertility of his farm. We repeat our advice to every farmer to keep well within the scope of his means, and not to hire more land simply because it is so cheap just now, unless he has sufficient means to

cultivate it thoroughly. We revert to our own white-chaff Red Wheat to call attention to the fact that the Wheat crop at the farm where it was grown was an exceptionally fine one, yet the crop in the field which had only a spring dressing of chemical manure was decidedly superior to those upon land which had been under sheep-folding or was dressed with farmyard manure. The chemical manure consisted of a mixture of nitrate of soda, steamed bone flour, and mineral superphosphate. Under the advice of Mr. Thomas Browne of King's Lynn, the able chemist of the West Norfolk Farmers' Manure Company, we used neither nitrate nor muriate of potash for the Wheat, and the result showed that he was right.

Of the comparative value of Wheat grown this year we are hardly competent to give a fully satisfactory opinion, as we have threshed so little as yet; but we may say that Oakshott's Champion White and Defiance Red are both so good that we shall sow them upon all our farms now. The Champion is a fine, bold, bright sample, a bushel weighing about 64 lbs., many of the ears being fully 6 inches in length. Defiance Red, though not so long in ear, is a heavier Wheat, weighing 70 lbs. a bushel. Webbs' Giant White Wheat was a magnificent crop, one field of 20 acres being alike remarkable for size of ear and length of straw. It is quite useless to attempt growing such Wheat in poor thin soil; to do full justice to it the soil must be deep and rich. Without such soil it deteriorates into ears of about half the size of well grown ears, and the grain is proportionately small.

(To be continued.)

WORK ON THE HOME FARM.

Sheep have been out upon the corn stubbles daily to consume fallen corn, much of which, however, sprouted quickly after harvest, and from the green appearance of many stubbles now we have proof that corn ripened so quickly as most of it was this year is very liable to be shaken out. Our flock of ewes at the home farm have the taint of foot rot, and they have been kept out upon the stubbles quite as much for the sake of their feet as for the corn they would get there. We can cure any case of foot rot, but it appears impossible to prevent it from breaking out again in a flock that has once had it. The only effectual remedy is to get rid of the entire flock and replace it with sheep known to be sound, taking care to keep them off pasture where the tainted flock has been till rain or frost has cleansed it.

Pigs have also been out on stubbles in care of boys, and advantage has been taken of their absence from the yards to clear out all manure, to dress all walls with hot limewash, and all woodwork with hot tar. Floors have been made hard and sound, drains examined and flushed out, and every precaution taken to render the piggeries clean and wholesome for the coming winter. If due attention was given to this important matter by every farmer there would soon be an end of swine fever; and the widespread prevalence of it which has led to the closing of so many markets is a sure sign of negligence in pig management. No doubt the pig will thrive and fatten upon garbage and in a filthy sty, but it fattens more quickly in a clean one where risk of disease is avoided, and the pork from clean-fed pigs is so superior in delicacy and flavour as to well repay for any extra care. We hear of the gradual increase of jam factories in Kent; when are we to hear of bacon-curing for sale by farmers? The process is very simple, close attention to details and good management being certain to ensure satisfactory results. Depend upon it "there's money in it," provided the requisite amount of energy, intelligence, and enterprise is brought to bear upon the undertaking.

Especial care has been given to farm horses lately. They have now been withdrawn altogether from pastures, and have dry comfortable bedding and shelter at night. Horses often sustain injury by being left out late in autumn upon pasture, and we then hear of colds and rheumatism, all which might have been avoided by the exercise of a little forethought and care.

THE CHEMISTRY OF VEGETATION.

In the course of Sir H. E. Roscoe's address to the British Association recently, the following remarks in reference to the vegetable kingdom are very interesting.

The phenomena of vegetation, no less than those of the animal world, have, however, during the last fifty years been placed by the chemist on an entirely new basis. Although before the publication of Liebig's celebrated report on chemistry and its application to agriculture, presented to the British Association in 1840, much had been done, many

fundamental facts had been established, still Liebig's report marks an era in the progress of this branch of our science. He not only gathered up in a masterly fashion the results of previous workers, but put forward his own original views with a boldness and frequently with a sagacity which gave a vast stimulus and interest to the questions at issue. As a proof of this I may remind you of the attack which he made on, and the complete victory which he gained over, the humus theory. Although Saussure and others had already done much to destroy the basis of this theory, yet the fact remained that vegetable physiologists up to 1840 continued to hold to the opinion that humus, or decayed vegetable matter, was the only source of the carbon of vegetation. Liebig, giving due consideration to the labours of Saussure, came to the conclusion that it was absolutely impossible that the carbon deposited as vegetable tissue over a given area, as, for instance, over an area of forest land, could be derived from humus, which is itself the result of the decay of vegetable matter. He asserted that the whole of the carbon of vegetation is obtained from the atmospheric carbonic acid, which, though only present in the small relative proportion of four parts in 10,000 of air, is contained in such absolutely large quantity that if all the vegetation on the earth's surface were burnt the proportion of carbonic acid which would thus be thrown into the air would not be sufficient to double the present amount. That this conclusion of Liebig's is correct needed experimental proof, but such proof could only be given by long-continued and laborious experiment, and this serves to show that chemical research is not now confined to laboratory experiments, lasting perhaps a few minutes, but that it has invaded the domain of agriculture as well as of physiology, and reckons the periods of her observations in the field not by minutes, but by years.

It is to our English agricultural chemists, Lawes and Gilbert, that we owe the complete experimental proof required. And it is true that this experiment was a long and tedious one, for it has taken forty-four years to give the definite reply. At Rothamsted a plot was set apart for the growth of Wheat. For forty-four successive years that field has grown Wheat without addition of any carbonised manure; so that the only possible source from which the plant could obtain the carbon for its growth is the atmospheric carbon acid. Now, the quantity of carbon which on an average was removed in the form of Wheat and straw from a plot manured only with mineral matter was 1000 lbs., while on another plot, for which a nitrogenous manure was employed, 1500 lbs. more carbon was annually removed; or 2500 lbs. of carbon are removed by this crop annually without the addition of any carbonaceous manure. So that Liebig's provision has received a complete experimental verification.

May I, without wearying you with experimental details, refer for a moment to Liebig's views as to the assimilation of nitrogen by plants—a much more complicated and difficult question than the one we have just considered—and compare these with the most modern results of agricultural chemistry. We find that in this case his views have not been substantiated. He imagined that the whole of the nitrogen required by the plant was derived from atmospheric ammonia; whereas Lawes and Gilbert have shown by experiments of a similar nature to those just described, and extending over a nearly equal length of time, that this source is wholly insufficient to account for the nitrogen removed in the crop, and have come to the conclusion that the nitrogen must have been obtained either from a store of nitrogenous material in the soil or by absorption of free nitrogen from the air. These two apparently contradictory alternatives may perhaps be reconciled by the recent observations of Warrington and of Berthelot, which have thrown light upon the changes which the so-called nitrogenous capital of the soil undergoes, as well as upon its chemical nature, for the latter has shown that under certain conditions the soil has the power of absorbing the nitrogen of the air, forming compounds which can subsequently be assimilated by the plant.

METEOROLOGICAL OBSERVATIONS.

CAMDEN SQUARE, LONDON.

Lat. 51° 32' 40" N.; Long. 0° 8' 0" W.; Altitude, 111 feet.

DATE.	9 A.M.				IN THE DAY.				Rain		
	Barome- ter at sea Level.	Hygrome- ter.		Direction of Wind.	Temp. of soil at 1 foot.	Shade Tem- perature.		Radiation Temperature			
		Dry.	Wet.			Max.	Min.	In sun.		On grass	
1887. September.	Inches.	deg.	deg.	deg.	deg.	deg.	deg.	deg.	In.		
Sunday .....	18	30.365	54.0	51.3	56.2	64.1	47.8	109.4	44.8	—	
Monday .....	19	30.499	53.8	50.7	56.0	62.9	47.7	103.6	42.7	—	
Tuesday .....	20	30.338	58.0	54.6	55.7	63.1	45.3	94.6	40.2	0.010	
Wednesday ..	21	30.355	51.2	51.7	55.6	60.6	50.3	85.4	47.1	—	
Thursday .....	22	30.320	56.3	51.5	55.8	67.2	48.9	114.3	42.3	—	
Friday .....	23	30.419	54.7	51.1	55.5	62.0	45.4	88.1	38.7	—	
Saturday .....	24	30.471	51.9	47.7	55.8	64.2	49.9	71.7	41.4	—	
		30.395	54.7	51.2		55.8	62.0	47.9	95.3	42.9	0.010

REMARKS

- 18th.—Generally bright and fine.
  - 19th.—Bright and pleasant, with cloudy intervals in early afternoon.
  - 20th.—Generally dull, though bright early and occasionally during the morning.
  - 21st.—Fine, but with little sunshine and much cloud.
  - 22nd.—Very bright and pleasant.
  - 23rd.—Very dull morning, bright after about 2 P.M.
  - 24th.—Cloudy and dull throughout.
- A fine seasonable week. Temperature about the average, and remarkably similar to that of the preceding week.—G. J. SIMONS.





## COMING EVENTS

6	TH	Crystal Palace Hardy Fruit Show (three days).
7	F	
8	S	
9	SUN	18TH SUNDAY AFTER TRINITY.
10	M	
11	TU	Royal Horticultural Society—Fruit and Floral Committees at 11 A.M.
12	W	

### DAFFODILS IN POTS.

**T**HE value of Daffodils for pot culture or for the general embellishment of the conservatory or greenhouse in the early months of the year has been much overlooked in late years. It is strange, too, that while the showier varieties have been lost sight of the Polyanthus section, which include all those bunch-flowered forms that are, strictly speaking, varieties of *Narcissus tazetta*, have been grown and forced for their flowers. Very desirable, certainly, are some of these varieties, notably the Paper White, *Narcissus tazetta* var. *papyraceus*, so extensively employed by bouquetists, but in reality are not to be compared with the great number of good and useful Daffodils which from a decorative standpoint are in their way unique. For the conservatory, from January to April and May, Daffodils may be had, and in the latter months abundantly out of doors, and while they embrace so much variety, and come in such succession, they may be had without much difficulty. Before proceeding further it may be well to explain the best method of growing them in pots for early flowering. Those who would have a supply of Roman Hyacinths to bloom early—say from December 1st onward to Christmas—would of course procure the bulbs as early as possible in autumn, and pot and plunge them in the ordinary way out of doors, so that they may make a plentiful supply of roots which will enable them to endure the heat to which they will be subjected by-and-by. A great deal of the after success depends on this alone, and it applies with equal force to Daffodils and *Narcissus* when similarly grown. Pot the bulbs early, and any soil that will suit Tulips, Hyacinths, Fuchsias, and the like will suit the majority of the *Narcissuses*. Stand them out of doors on an ash bed, and cover with 6 inches depth of similar material, in which they will be safe for some time to come. The length of time they should remain will depend on the varieties; for instance, *N. pallidus præcox*, quite a general favourite, may, without forcing, be had in flower in January, when Chrysanthemums and many other winter flowers are on the wane, then such a one would be not only useful but very welcome. In mild winters and favoured localities this Daffodil has flowered previous to Christmas, and in more frequent cases in January out of doors. The treatment for this one, then, is a frame from which frost is excluded, and if it is needed for successional plants some may be on the north side of a pit or frame and others in the frame. The same treatment will be found to answer in the case of *N. scoticus*, which brings up the succession, and is nearly allied to the first named in general aspect and form.

For a variety with bold, sturdy, golden cup for flowering in February we cannot have a better one than the Tenby Daffodil, *R. obvallaris*. This is without doubt one of the best of all for pot culture and forcing; it is grown by tens of thousands for Covent Garden Market, is highly appreciated, meets with a ready sale, and is always admired. It is specially adapted for pot culture owing to its vigorous and sturdy habit, so that it does not require sticks to keep the foliage in its place, which for some, particularly the varieties of *N. incomparabilis*, that grow taller and with more slender leaves, are needed to keep them from presenting a ragged, neglected appearance. This variety may be had in January if potted early and introduced into heat, which should be slight at first, about the middle of December, increasing it after a fortnight or so; but at no time will it be necessary to give it more than a temperature of 50°, that is if any value be placed on the bulbs afterwards. Another reason apart from the safety of the bulb hereafter, why I do not advise any strong heat to be given them is, that being grown as cool as circumstances will permit, the flowers last a much longer time when expanded than they do if hurried along in strong heat. There is little need for this if the successional varieties be taken in hand as I shall recommend, and worked on judiciously; but if flowers must be had at any risk, as they must in many establishments, then my advice is to get the commonest varieties possible, the loss of the bulbs of which will not be serious, and pot them at the end of July, so that no chance will be lost for their making a start as soon as ready, and such as these may be had in flower at Christmas if plenty of heat be at hand, and after blooming they will be fit for throwing away. Do not attempt placing them in strong heat for a moment unless you are fully convinced that abundance of roots have been made, or the chances are that you will fail in getting them to flower.

Among the earliest I must not omit *Corbularia conspicua*, the Golden Hoop Petticoat *Narcissus*, which is exceedingly free-flowering and effective with its flowers issuing from its tuft of grassy leaves. It is a pretty flower, and being cheap should be grown in quantity. It is very pleasing in the conservatory as a margin, alternating with Maidenhair Ferns, but it cannot endure much heat, at least such is my experience of it. Then, for varieties to bring up the succession we must look to the more diminutive *N. nanus*, so charming for fringing the stage in the greenhouse, while *N. minor* is a larger form much in the same way. Following these we find in the forms of *N. spurius* a series of bold and characteristic flowers, many of which are exceedingly handsome and far too valuable to be tampered with in heat. The type, however, is sufficiently cheap and plentiful to allow of its free but judicious use in pots, and included with this may be the major form, also *N. spurius* Henry Irving and Golden Spur. These two latter are grand additions, the last especially so; the flowers of this are large, rich yellow, with a bold broad lip, expanding trumpet, much larger than the better known *N. maximus*, and altogether more vigorous. I consider this, with the *N. spurius coronatus*, the two giants among the grand Trumpet Daffodils. These two, if grown in pots, should have plenty of room, and only be given frame protection till they are more plentiful than at present, as giving them much heat materially damages the bulbs, and they do not recover under two, and in some instances three years.

I cannot but call attention to one of the best, yet one

of the commonest of all the race, I mean the old double Daffodil of gardens, *N. Telemonius* fl.-pl. The great demand for this variety alone is in itself sufficient proof of the growing taste for flowers, and how eagerly even the most commonplace plants are sought after when it is found that they may be produced much earlier than is their wont by growing them in slight warmth. The reason probably why this particular variety has so quickly gained the favour of the flower-loving public is on account of its noble flower and rich colour, a colour, too, which seems to find many admirers at the present time; and since it is readily produced in quantity early in the year, when flowers are so much needed, there is every probability of it proving serviceable, and well managed it may be had for weeks in succession.

Leaving the gold and yellow forms we will just take a glance at some of the most prominent of the *N. bicolor* group. Collectively this is a grand section and one always admired, and that deservedly. The whole of this group is distinguished by having a white and sometimes a sulphur or primrose-coloured perianth around a golden cup or crown, and it is not saying too much when I state that all are good. The best to be found in the type are *N. bicolor*, and such varieties as *N. b. Horsefieldi*, *N. b. Empress*. All of these are most telling flowers, Last in flower of this section is *N. b. grandis* (*maximus*), an immense flower with pure white well imbricated perianth and bold yellow trumpet; but the most useful, perhaps, is *Horsefieldi*, which is not only one of the best of its kind, but also one of the best in the whole army of spring bulbs. This may readily be flowered in March if potted early and placed in cold frames till the end of January, and thus treated it will not be likely to suffer, as it will then come on sufficiently fast in an ordinary greenhouse. In the *N. lorifolius* group we have good well-known varieties in *Emperor* and *rugilobus*, and well suited to pots.

Large numbers of varieties are also found in the *N. incomparabilis* section, but taken as a whole, while it includes many valuable forms and pleasing tints, it is perhaps the least suited to pot culture under glass. This is perhaps mainly due to the general want of substance in the perianth segments, as these when brought on in heat quickly shrivel when used as cut flowers; therefore I do not recommend them. They may, however, be grown in cold frames or in sheltered positions out of doors, and especially so the mixed seedlings of the commoner forms, and thus grown they are very useful, and as a whole freely flowered.

Amongst the true *Narcissi*, of which portions may be regarded as typical, we have some of the most useful of all, admired alike for their fragrance as well as for their general decorative value. In the first place they may be divided into early and late groups, the best of the former being *N. p. ornatus*, which flower naturally in March and April, while in the latter we find *N. poeticus* and *N. poeticus recurvus*, both single forms, and the double white Gardenia-flowered *Narcissus*, *N. poeticus* fl.-pl., which flower in May. To select an individual from these no one having previous experience would do other than name *ornatus*, for of this hundreds of thousands are annually distributed from Covent Garden Market alone. The pure white perianth is of good substance and well formed, in some flowers they are somewhat imbricated, the cup being narrowly margined with scarlet. With good and careful treatment this may be had in flower from January onwards, and it well repays good culture. Of the Double White I cannot say much as to its forcing

properties, for I have not given it sufficient trial in quantity. One thing is certain, well established bulbs must be had or the buds will go blind in the scape prior to expansion. It is, however, excellent out of doors when established, and to those already named, which include some of each group suited to the above named purpose, may be added a selection of the forms of *N. Tazetta*, all of which are useful, and have in the great majority of instances powerfully fragrant flowers.—NARCISSOPHILE.

### PLUMS UNDER GLASS.

THROUGH the vicissitudes of our climate the cultivation of the choicer Plums outdoors is uncertain. There is the danger of loss of crop from frost or prolonged cold, sunless, and it may be, wet weather at the flowering period, which so interferes with the development of the blossom as to result in imperfect fertilisation. There is also the liability of the fruit to crack when ripening, especially if rain follow a period of prolonged dry weather, which so mars the appearance of the fruit and invites the attacks of wasps and bluebottle flies as to render it unfit for dessert. There are other conditions, as, for instance, a cold, wet, sunless season, which prevents that perfection so much coveted alike for the fruit of the current season and in the wood and buds for the succeeding year's crop. The fruit will fall through the imperfect fertilisation in the early stages of swelling.

I consider Plums are much richer and more desirable than Apricots, Peaches, and Nectarines. The choicer Plums are simply "sweetmeats," but they never attain to as great a certainty of perfection of crop, size, and quality outdoors as under glass. True, very much finer fruits are had from trees against walls, and much can be done by protecting the blossom in an unfavourable spring, or by the use of glass copings when the fruit is ripening, yet there is a great difference even between that grown against walls and that grown entirely under glass, even in a season like the one drawing to a close. There is no reason why Plums should not be grown much more extensively under glass, but it is very desirable that only the finest, alike in appearance and quality, be grown. Select those of the very best quality only. I have charge of a case 100 feet long erected against a wall with a south-east by south aspect. The wall is 12 feet high, and the case is 6 feet wide, having 3 feet upright front lights and those open for ventilation, as well as a similar width of top-lights, and the roof or sloping lights are moveable, so that the trees can be exposed to the winter's enriching influence of rain and snow, the border getting thoroughly moistened, and by keeping off until the buds are moving there is less reason to apprehend damage from spring frosts. The trees are trained to the back wall only, but up the front to a height of about 6 feet. Tomatoes are planted about 18 inches apart, and trained single cordon style, on which the fruit hangs like "ropes of Onions." *Acme*, *Hackwood Park*, and *Excelsior* are the sorts grown, and my opinion of them in merit is in the order named. Only a few varieties of Plums are grown; indeed the trees are fan-trained, so that there is not room for many trees. *Green Gage* is the earliest, followed by *Jefferson*, then *Transparent Gage*, *Coe's Golden Drop*, and *Guthrie's Late*. There is another variety, probably *Decaisne*, which ripens in advance of *Coe's Golden Drop*, otherwise the similarity is strong. The trees occupy the whole of the back wall of the case.

The soil is a rather strong loam interspersed with flints, the subsoil clay, the "formation" chalk. As regards cultivation, it does not differ materially from that afforded trees against walls outdoors, only there is the necessity of watering and syringing to keep aphides and red spider in check. Feeding can be carried out to any extent, and mulching will save much watering, besides encouraging surface roots. When ripening, water must be kept from the fruit, and the house freely ventilated, as a moist stagnant atmosphere is fatal to perfect finish. What I wish particularly to note is the greater firmness of flesh Plums assume when grown under glass as compared with similar varieties grown outdoors, and their increased richness.—A GARDENER.

### CHRYSANTHEMUM NOTES.

I WOULD suggest that you find room, under this heading, for any notes sent you from this time forward, as in former years. No two seasons are alike, and even the same variety will differ from year to year. The present should have been a capital year for ripening the wood, which—all things else being satisfactory—is generally considered the forerunner of superior blooms. Yet many growers both for show and decorative purposes complain of insects and other

depredators. I have seen many clubbed and fasciated stems with imperfect buds; what are such the result of? A friend showed me to-day very fine plants 10 feet high and seemingly well grown of Belle Paule, and on which he found it impossible to "set" a crown bud. This is not the first time this capricious beauty has been complained of in this way, and I am not sure if it is not less disappointing to depend on terminal buds. What has been your readers' experience so far? In the same collection, grown for large blooms, I saw a cut-down plant of Madame C. Audiguier, with large solid fine buds half an inch through; while another, with the same treatment, grown unchecked, 11 feet high, had most unpromising buds on the top. I mention this peculiarity because the reverse would be expected. It is so of Soleil de Levant, Aurore Boreale, and Balmoreau, so that there seems good reason for the contention that those tall-growing varieties might in many cases do better as cut-down plants. Mandarin, creamy rose, set down among early flowering, I have not found at all so. Alexandre Dufour, Isidore Feral, and Pynaert van Geert, come next after Madame C. Desgranges and its sport, G. Wermig, as the largest and best early bloomers. Of new ones most promising with me are William Holmes, Phœbus, La Triomphante, L'Ébouriffée, Bronze Queen, Martha Harding, Brazen Shield, Le Cid, and F. Wilcox.—W. J. MURPHY.

PROSPECTS OF THE CHRYSANTHEMUM SEASON.—If the prospects of a good Chrysanthemum season can be gauged by the appearance of the plants at this season of the year in various parts of the country, then I consider a capital result will be forthcoming. I have lately had opportunities to inspect collections of plants in several different localities, and a few notes on their present appearances may interest some growers. I consider that northern growers will have an advantage over their southern brethren this year by reason of the excessive drought prevailing for so long a period this year. Chrysanthemums are sun-loving plants, but when there is an excess of heat accompanied with such a drought the plants suffer. In addition to this, where the supply of water is scarce and the whole after a time has to be drawn from wells or water companies' pipes, and used direct on the plants without means of airing it in the sun for a short time, it is a great disadvantage. In the northern counties the sun has not been so scorchingly hot nor the drought so long continued; the night dews are also more numerous and heavy during the summer months. This is proved by the appearance of the crops in the fields of Turnips, Potatoes, and grass land, which in the southern counties during August and September were generally dried up. Chrysanthemums to produce fine flowers must have well-ripened wood, but some growers affirm it can be too ripe. The present season will go a long way towards testing the accuracy of this. In nearly all instances where grown for large blooms plants are dwarfer than usual; particularly was this noticeable in the Queen family, as owing probably to a cold sunless spring the plants did not make the usual progress. Under these circumstances, if the flowers are equally good so much the better, yet I noticed one or two collections where the usual heights of varieties were reached. It is strange that there should be this difference in plants in different places.

To commence with the plants as I saw them, Trafford Park, Manchester, the seat of Sir Humphrey de Trafford, first claims attention. Here about 700 plants are grown for all purposes, most of course upon the large-flowered method. The whole stock was characterised by a healthy appearance, more so by their great size of either stems or leaves. Many fine flowers no doubt will develop from these, but another season Mr. Lowrie will have much finer plants, as he has only lately taken charge of these gardens. What struck me most was the very dwarf nature of the plants. Fair Maid of Guernsey was only about 3 feet high, but carrying stout flower buds, yet the cuttings were struck at the ordinary time (December).

Darlington.—The collection belonging to Mr. T. B. Morton, Mowden Bridge Nurseries, came next under notice. Mr. Morton has made himself famous in the north of England in the cultivation of Chrysanthemums; in fact, he has done much more in his neighbourhood and for fifty miles around than any other person by showing good blooms, thus stimulating others to grow the flower well. He is an annual importer of new varieties, and has this season many promising under trial, many being of a dwarf habit of growth. Mr. Morton grows about 1000 plants, all for large blooms. They ranged in height from 3 feet to 10 feet, Val d'Andorre being the shortest, while Belle Paule and Madame C. Audiguier were the tallest. Mr. Morton is favoured considerably in the position which his plants occupy in such a summer as the past, the ground upon which the plants are arranged being low-lying, a brook running close past. In other seasons he has had wood and leaves so large that a difficulty was experienced in getting it sufficiently ripe. This year his plants are not so stout, consequently they are

much more ripened. Healthier looking plants could nowhere be found. The buds, too, are well formed, and on the whole promise well for future flowering, reflecting much credit on Mr. Morton. Another garden in the neighbourhood of Darlington demands notice, that of A. Pease, Esq. Hummersknott. Mr. Short, the gardener here, grows 400 plants on the tall-flowered principle, which are moderately strong, with fair leaves, wood pretty well ripened, and promise to make a good show at the proper time, the buds appearing to be well timed.

The Liverpool district has long been looked upon as a centre for Chrysanthemum growing, and right well do the plants in the neighbourhood look. Nowhere in England could so many plants be found in the same area as about Liverpool. So enthusiastic are the gardeners of that place in the cultivation of the Autumn Queen that it is no wonder such good results have to be chronicled from time to time.

Wyncote, the seat of the late C. W. Newman, Esq., in Allerton, has long been noted for this flower. Although all other plants have been sold since the death of Mr. Newman the Chrysanthemums have been retained; therefore, with any amount of house room Mr. Mease will have ample accommodation for his plants, which look remarkably well. The plants are tall, strong, possessing stout leathery leaves, the wood also being well ripened. The buds were plump, of good form; in fact, the whole appearance of the plants betokened much care having been spent upon them.

Dove Park is the seat of G. Cope, Esq., where about 300 plants are grown. The whole have a particularly healthy appearance, being short-jointed with ample foliage. Considering that Mr. Carling did not take charge of these gardens until January, no doubt another year, when he can set about their propagation sooner, his plants will be better. Still, he will have many fine blooms judging from the flower buds. Here the Queen type was very dwarf as compared with what they are in some seasons.

Camp Hill, the residence of F. Gossage, Esq., is well situated for the growth of Chrysanthemums, being open to the sun and well sheltered from north and easterly winds in the spring. Mr. Jellicoe has here some grand plants carrying fine foliage, as they always do under his system of treatment. With a view this year to reducing the height of the plants generally, many were stopped in their early stages of growth by pinching out the point of each leader. By this means many are shorter than they are in some seasons when left to grow naturally. The plants generally under Mr. Jellicoe's charge are shorter this year than usual. Some grand examples of Princess of Wales gave promise of developing that grand variety in its best form.

Otterspool, the residence of Sir T. Edwardes Moss, has of late years become famous in the Chrysanthemum world, and judging from the appearance of the plants is likely to remain so. Good wood and leaves right through the whole collection were noticeable. Princess of Wales, Fair Maid of Guernsey, and the whole of the Queen family were particularly robust. Mr. Lindsay had some plants pinched in February and March, but there was no difference between the height of such plants and those grown naturally. Many of the plants are intended to produce more flowers than the orthodox number (three).

Glen Hall, Wavertree, the gardens here are under the charge of Mr. Cox, who during the last few years has taken a leading position amongst Chrysanthemum growers, and he has this season a collection of good plants not particularly strong in growth, but having stout leaves and promising buds, all compactly arranged in two blocks; the wood is wiry and capable of producing blooms of good quality.

Sandfield Park, West Derby, the residence of W. D. Holt, Esq. Mr. Roberts, the gardener here, is well known as one of the best growers of the Chrysanthemum we have. For many years he has been a persistent worker. Old in experience, but young in years, he is much respected among the "fancy." He has this season about 400 plants, all grown on the natural method of culture—that is, without pinching the points to induce a dwarf habit of growth. Mr. Roberts is not a believer in extra strong growth; rather a medium strength of wood with vigorous leaves, the whole plant well ripened, is what he believes in and strives to produce, and it might be said he has secured this year. His plants had a capital tone of colour and leathery texture of leaf. He will no doubt be heard of later on when the shows come around.

Childwall Hall, the seat of R. Brocklebank, Esq., has lately become known to Chrysanthemum fanciers from the golden sport from Meg Merrilies having originated here. Beyond a doubt it is one of the best introductions of late years, and judging from the number of plants grown of it, a fine show of blooms will be on view. As many as fifty plants grown in 7-inch pots, cuttings of which were struck in April, grown with one stem, looked remarkably healthy, being of course dwarf in growth owing to the lateness of the time at which the cuttings were struck. Several other plants



of this variety, grown on the orthodox principle also looked very promising, showing clearly this variety has a constitution equal to its parent. Some of the plants had been pinched, but no difference was perceptible in their appearance, all assumed the same periods of growth, &c. A collection of other varieties is also grown, not remarkable for numbers, but all showing traces of careful cultivation.—E. M.

### MORE ROOM FOR VINE SHOOTS.

THE importance of training the shoots of Vines, and indeed of all other fruit trees thinly, is well known to all observant and practical fruit growers. The practice has been advocated in the horticultural press perhaps as long as it has been in existence; and judging from the crowded state of the shoots on hundreds of Vines grown under glass in this country it is still necessary to urge its importance. The exchange of ideas through the medium of the press is productive of a great amount of good to gardeners as a body, as it often brings to their minds the necessity of doing many things that would perhaps escape their notice until too late. These thoughts have often occurred to me when reading, as I have done for years, many of the valuable articles contributed to this Journal, from which I have gained much sound and useful information. But to return to my subject. The present is a capital time to examine Vines and all kinds of fruit trees that have been cleared of their fruit before the leaves have fallen, as it can now be easily seen where they are too much crowded. They can be thinned accordingly, so that the ripening influence of sun and air during the next month may have a beneficial effect upon those buds from which we hope to get our next year's supply of fruit. I am of opinion that in many cases we might with advantage train the shoots of Vines a little more thinly than is usually done, taking especial notice of the size of leaf and wood of each variety.

Another matter that must not be overlooked is that those varieties that are liable to be injured by scalding should have the spurs a little closer together. Lady Downe's, although rather a strong grower, should have the shoots a little closer together than most other varieties on that account. All Vines in good health produce a great many more bunches than they can bring to perfection, so then it is clearly not necessary to crowd the shoots in order to get a sufficient quantity of fruit; and when quality is considered those Grapes grown on Vines trained thinly are far in advance of the apologies for bunches we sometimes see suspended from a thicket of Vine shoots. When the main laterals are trained closely together and stopped at one or two joints beyond the bunch there is very little if any room for sub-lateral growth without it is allowed to crowd the main leaves. I am a great believer in allowing Vines plenty of freedom during the growing season, so long as the young growths do not unduly crowd the main laterals.

I have, after much careful observation, come to the conclusion that all white Grapes should have the spurs farther apart than black Grapes, as I am convinced that to have them coloured to perfection the diffused rays of sunshine should be able to reach the berries from the time they begin swelling. They then gradually assume the beautiful amber tint all Grape growers admire, but which can never be obtained where the berries are grown under a thick canopy of foliage until they are nearly full sized, and then exposed to light by having the leaves tied back. Trebbiano is a variety that grows very strongly and produces enormous leaves, and is really a fine Grape when well coloured, as it is sometimes seen, but when grown in the ordinary way it is difficult to get sufficient light upon the berries to colour them as they should be. If the Vines are planted 4-feet apart and the spurs 22 inches distant from each other, the sun acting upon the berries during the whole of the growing season gives them a pale colour throughout, quite different from the deep green colour during the growing period of those of the same variety growing with more foliage overhead. By the time they are ripe those grown under the influence of the greatest amount of diffused sunlight are a long way ahead in colour of those grown under the shade of foliage and afterwards exposed to full sunshine. This I have noticed in several instances during the past few years.

Muscats and Foster's Seedling not being such vigorous growers will succeed well with the spurs from 18 to 20 inches apart. Gros Colman, Gros Guillaume, and Gros Maroc will do wonderfully well at that distance apart, which will allow plenty of room for the wood and foliage to develop, and still supply a sufficient canopy of foliage to enable them to colour well, as I consider all thick-skinned black Grapes colour best when a fair amount of light reaches them. As far as my own experience goes, however, Black Hamburgs colour the best under a good canopy of foliage, and for this reason I should advise that shoots be trained about 15 inches apart, and a good run of laterals allowed at colouring time. Madres-

field Court with us is only a moderately strong grower, and the shoots are trained from 15 to 18 inches apart, and the laterals are allowed perfect freedom from the time they commence to take their last swelling till the fruit is cut. Mrs. Pince, although not a strong grower, should always be trained thinly, as it delights in plenty of growth beyond the bunch. We sometimes allow three or four joints beyond and have the spurs from 18 to 20 inches apart, so that the shoots on one kind can be extended beyond those on the next. We invariably find that the sides of the bunches facing the sun are the best coloured.

When the Grapes are cut the present is a capital time to examine each Vine, and when the spurs appear too much crowded cut some of them out and remove all sub-laterals from those left, and in the earliest house shorten the main laterals to within five or six leaves of their base. This exposes the remaining portion thoroughly to the ripening influence of sun and air, and cannot fail to have a beneficial effect upon them by causing the buds to become plump and solid. Some persons appear to be doubtful as to the utility of this operation, and I think it may do more harm than good if performed too early, but for early Vines intended for starting in November or December from the middle to the end of September is the best and also a safe time. If all sub-laterals have been previously removed some time during August the reduction of foliage is a gradual one, and it is certainly not advisable to cut away a great amount of wood from Vines at one time, especially if the Vines are still making vigorous growth. The roots must then be in an active condition, and it is only natural to suppose that a sudden curtailment of top growth must cause a corresponding decrease in the root-action. After Vines have been forced early for several years lateral growth will be almost if not quite completed by the middle of September, and by removing the shoots as above indicated no great check can be caused; and, moreover, the enfeebled energies of the Vines, instead of being wasted in the production of useless growth which cannot be ripened, will be concentrated in the next bloom buds, to which we look forward hopefully for something good the following year.—H. DUNKIN.



### COMPOST ABOUT THE ROOTS OF ORCHIDS.

ONE of the prevailing evils in the culture of plants is repotting them before they really need it, and placing them into pots too large with too much material for the roots to ramble amongst. This is especially noticeable in the cultivation of Orchids, and not only amateurs, but many gardeners, young, old, and middle-aged fall into this error, with the result that the plants are frequently found in a sickly condition and are finally lost.

Thousands of imported plants are annually killed by placing them directly they are received into pots too large for them, and cramming about their stems as much soil as would with care and proper treatment last them for five or six years. Under such conditions the plants very rarely start freely into root-action or growth, and those that do so are liable to lose the whole of the roots they have made during the first winter. To try to recruit plants that have decreased in strength will end in failure, as under the best treatment a very small percentage can be restored. It is far more satisfactory to start with healthy imported Orchids.

Imported plants show unmistakably that they have been torn from trees, rocks, or some similar position with but a little moss, small Ferns, and decayed vegetable matter amongst their roots. The latter upon examination will very generally be found to be pseudo-bulbs that have decayed with moss and the roots of small Ferns that have become established amongst them. If beginners who have no knowledge of the culture of Orchids are to attain success they must follow Nature as nearly as possible, for it is much better to start the plants into growth and root activity without soil than by its aid. Whether placed in pots, pans, blocks, rafts, or in baskets they should be allowed to make good roots and have started their new growth before an attempt be made to place either peat fibre or moss about them. If placed in a warm, intermediate, or cool house where the moisture maintained is sufficient for healthy plants, whether Orchids or otherwise, they will start freely, and the moisture in the house at first is all they need until they are plump and show signs of rooting, when they can be dipped occasionally, or syringed so as to maintain moisture about the crocks, charcoal, or block upon or amongst which they are secured. If they are placed in pots, pans, or baskets, the smallest, according to the size of the

plant, should be used, and these filled with crocks or charcoal in lumps. It is also necessary in many cases to elevate the plant above the rim. Under these conditions there is very little fear of their becoming too wet, which is of vital importance if the plants are to make strong growth. When root-action has well commenced some of the crocks or charcoal may be carefully removed, so that about 1 inch of peat fibre or moss may be added to the surface. This is necessary for the sake of economy, and will materially reduce the labour in keeping the necessary moisture about the plants. This will be ample for the first year, and in many cases for two or three years until it is decomposed.

Often we have noticed that plants started in the most satisfactory manner have been overpotted the following season. This is a very general mistake. Who has not observed sturdy *Odontoglossums* in 2-inch pots placed the second season into those 6 inches in diameter, or *Cattleyas*, *Laelias*, *Aerides*, and others started in 5 and 6-inch, transferred into 8 or 10-inch pots, pans, or baskets? Frequently when they are turned out they have few roots. If a collection of Orchids be examined, it will be found in nearly all cases that those apparently restricted are the healthiest, possessing better and more roots than those plants in pots too large for them. It must not be concluded that I advocate any system that will unduly restrict the growth of these plants. They should be allowed to take full possession of the material given them, and then increase the root space. Orchids do not need potting on annually. To avoid potting too often the material used should be of the very best, and of such a nature to last until the plants have crowded it with roots, as well as the crocks or charcoal used for drainage. The plants will not only cling to these, but in most cases firmly to the pot.—W. B. L.

### ASPARAGUS CULTURE.

(Continued from page 268.)

**GENERAL CUTTING.**—In a plantation of Asparagus there are several degrees of size—viz., small, medium, and thick. The small is good in soups, the medium may pass for the servants, and the thick is esteemed by everybody. The large heads are all cut up to the very last, and the shoots reserved for furnishing the buds for next season's crop are the "weaklings" of the current year's growth. The heads in subsequent years are not so good as in the fourth or even third year from the seed. All the best heads are cut and the buds are expected to afford them indefinitely. If fine heads are wanted the "grass" must be fine in the previous season; therefore, some of the best must be allowed to remain in time to form a strong haulm. The medium growth must be treated similarly—i.e., save one growth at least of equal vigour to the heads cut, or if not wanted allow the first head to remain until the second appears, when it being stronger cut away the first, and so on as advised for seedlings in the third year. So likewise with the small; if not wanted leave the first growth until the appearance of the second, and so on to midsummer. To save bother and prevent mistakes cut all great and small up to the third week in May in an early, or the end of May or early June in a late season, then leave the strongest growth at the time indicated, one at least to each stool, or more according to its size and age, and get the number required within a fortnight of the first reservations.

**THINNING.**—Apportioning the growths to the vigour of the plants is a very important matter, for as the "grass" is one year so are the heads the next; therefore, the fewer growths the energies of the plant, and nutriment of the soil is concentrated upon the stronger will they be. It, however, requires to be taken in relation to light. From a crowded growth we have quite as much "grass" as from a thin growth weight for weight, but the first is sprue and the other large. The more distance the Asparagus is given (always having regard to judicious employment of space) and the better it is attended to the finer it will be. If the heads are wanted fine the "grass" must be thin, and so grown from the beginning, all haulm left having space for its full development without crowding from the day it appears as heads. It will not do to let all grow together until say early July, and then cut half or a large portion away, though that is better than leaving it a perfect thicket until the end of the season, for the character of the Asparagus next year is then already formed; therefore, thin early, and finally by or before July.

**SECURING PLANTS FOR FORCING.**—In preparing plants for this purpose the course advised in the third year will prove satisfactory, they being allowed to make three years' growth as seedlings, or two after transplanting before lifting; but the plants will not have attained to their maximum of vigour generally, and I therefore advise their not being lifted until the close of the fourth year's growth. In the fourth year the first heads may be cut, but there must be a reservation by the middle, or at latest, the third week in May, cutting away all other growths as they appear. The number of growths may be three to five, according to the strength of the plants, but as a rule those having least growths left give the finest heads, which of course depends on the vigour the haulm exhibits in the previous year. By selecting the early growths the buds are perfected earlier, and are consequently better adapted for forcing. Cutting the first heads and selecting the second or third secures to the latter a more favourable season of development than

were the first or second retained, which are liable to suffer from frost or be stunted by cold.

**SECURING EARLY HEADS.**—Plants treated as above may be covered with handlights, those at the 3 feet stations. I use 2 feet square boxes, 11 inches deep of inch deal, with loose hipped tops, glazed with 21 ounce glass. They should be placed on about the first week in March and the top put on, keeping it close, the soil being brought up the sides of the boxes a little so as to exclude air, but that is not material if only they rest evenly and closely on the surface. The sun will heat the air inside and the earth absorb it; therefore place a little litter on the ground around the boxes, and throw a mat over the lights when the sun leaves the glass, withdrawing it whenever the sun shines. The heads will appear in due course, and they can be blanched if required by putting on suitable material, still following the same course with the lights. If we want English Asparagus we must ventilate by placing the top more or less across the corners, so as to admit air, and we have only to place the mat over the handlight at night, closing early. Ten days or a fortnight make a difference in the estimation and price of Asparagus, besides the certainty of escaping damage from frost. The handlights, it is needless to say, should be removed gradually so as to inure the plants to the change. The plants so treated afford heads earlier the second year than the first, therefore keep to them for the early supply. Early Purple-topped Argenteuil is the best for this purpose.

**INSECTS.**—I know only one that attacks this plant—namely, the Asparagus beetle (*Crioceris asparagi*) the larvæ of which feed upon the leaves, gnaw the rind, rather devour the stems, and perforate the buds. The only remedy is to place cloths on the ground under the haulm, shaking the beetles and larvæ on to them. A gauze net answers even better than the cloths, holding it with one hand and shaking sharply with the other. These pests are most fond of the tender extremities of the haulm. They may also be destroyed by hand-picking, which, however, is a very tedious process. The larvæ, beetles, and eggs are found from June to the end of September.

Slugs are very destructive to the young heads, eating them off whilst in the ground and even whilst dormant. The only remedy is a dressing of salt, or preferably nitrate of soda, but they very often escape these applications through the Asparagus crowns being at a considerable depth; therefore remove the soil over the crowns where the slugs are troublesome, leaving no more than from 3 to 4 inches thickness of fine soil.—G. ABBEY.

### THE HOLLYHOCK.

WHEN I wrote some months since regretting the want of interest felt in the Hollyhock, and spoke of the olden times when the Hollyhock was a most popular plant and we had so many grand varieties, I little thought that there were so many growers about, and it has given me very great pleasure to see the various communications in the Journal respecting this flower. Mr. William Paul's communication was especially welcome, for his "Hour with the Hollyhock," and the interest he took in this flower when he was at Cheshunt, are well remembered by some of us "old ones." The old National Floricultural Society did an immense amount of good whilst it existed, and I often refer to its printed reports to freshen my memory and look over the list of plants and flowers exhibited there and the names of the Judges, the greater part of whom have now passed away. Mr. Mundell's letter also gave me much pleasure, and I have since found that the Hollyhock is again taking roothold in so many places, and bids fair to assume a leading position at our autumn shows.

I have to thank Mr. Steel most sincerely for his courteous reply to my note through the Journal and for the list of his varieties. I should like to see old Memnon again, a grand old crimson sent out many years ago by Mr. William Paul. I cannot remember in what year, but on referring to the "National Garden Almanac" for 1856 it is mentioned as one of the best crimsons then in cultivation, and Black Prince, raised by Gibbons, mentioned by Mr. Steel, is also in this list. I am not a grower of Hollyhocks at present, except a few plants Mr. Blundell kindly sent me, but if spared until next year I hope to grow a quantity and must go to our good grower for supplies. I am therefore unable to comply with Mr. Steel's request.

My old friend Mr. William Boston of Bedale knows what Hollyhocks were and should be as well as any man living. The late Mr. Parsons of Welwyn should have prominent mention amongst our old Hollyhock growers, for he was the raiser of several of the splendid varieties Mr. William Paul purchased and sent out, and ultimately the late Mr. Charles Turner bought Mr. Parsons's later seedlings, and I was sent to Welwyn by Mr. Turner to make a selection for sending out. The late Mr. Bragg of Slough, a well-known florist in years gone by, also sent out some good kinds, his own seedlings and those raised by his old friend, the late Mr. Roake, for many years gardener to the late Ed. Foster, Esq., of Clewer Manor of Pelargonium fame. Mr. Boston is quite right as to Mr. John Laing at Dysart, and I also well remember his Beauty of Dysart and others; and then Mr. Laing, still happily amongst us

and hearty, set the fashion in Scotland in Hollyhock exhibiting in conjunction with Mr. John Downie and others. I have seen glorious displays of Hollyhocks in the old experimental garden shows and others in the City of Edinburgh, and well do I remember the old B'shop Auckland displays when Mr. John Downie and I were Judges together for some years.

The disease question should have full information thrown upon it by our growers. In some plants I had from Bath this year the disease was perceptible in young plants, and I wrote to the sender about it, and he replied that the plants would grow out of it, and they did. With the winter before us there is ample time for a discussion as to the Hollyhock disease and its remedies, and our growers will do "the State some service" if they will give your readers their experience.—WILLIAM DEAN, *Walsall*.

MR. STEEL will find the following twenty-four varieties of Hollyhocks to be the best he could grow, twelve of which I have marked with a star as being the best twelve. Four of this number have been certificated by the Royal Horticultural Society and at the Crystal Palace during the last two seasons. Mr. Chater of Cambridge (son of the veteran grower), and an enthusiastic amateur grower himself, has pronounced *Crimson Queen* and *Wm. Archer* to be the finest he has ever seen. It is almost needless to add that these are most of the late Mr. Chater's own raising, and appeared in his last catalogue.

\* *Alfred Chater*, mottled rose; *Bijou*, scarlet suffused with buff; \* *Carus Chater*, fine glowing reddish crimson; *Constance*, delicate flesh; *Crimson Queen*, intense crimson, first-class certificate 1886; \* *Cygnets*, pure white, large and full; \* *Exultum*, blackish maroon, requires shading; \* *Fred Chater*, pale yellow, fine; \* *Fire King*, intense glowing scarlet; \* *Golden Drop*, deep canary yellow; \* *Grace*, apple blossom, first-class certificate 1886; \* *Jessie Dean*, soft silvery rose tinted with buff; *Marion*, purplish rose; *Marvelous*, deep orange buff; *Mr. Chater*, deep amber, at times tinted with carmine; *Perfection*, delicate silvery flesh; *Purity*, deep salmon flesh; \* *Primrose Gem*, pale primrose; *Prince Arthur*, pale yellowish buff; *Peri*, sulphur white; *Purple Prince*, fine in the spike; \* *Scarlet Gem*, scarlet flushed with cerise, first-class certificate 1887; *Victor*, bright cerise; \* *Wm. Archer*, deep reddish purple, first-class certificate 1887.—G. WEBB, *Saffron Walden*.



THE FROST.—Mr. Wm. Jenkins, Aldin Grange, Durham, writes:—"On the morning of the 28th we were surprised to find there had been 8° of frost. Chrysanthemums were all drooping their heads and looked almost as if there had been a fall of snow, so dense was the frost on the foliage, and the soil was frozen hard in the pots. The late varieties, the points of which were soft, have suffered the most. About a dozen plants of *Boule de Neige*, upon which I was depending for blooms in January and February, are injured almost beyond recovery. *Mrs. C. Carey* is drooping its head with the leaves quite black. I do not find that the earlier varieties have suffered at all where the bud, had been taken and the foliage became hard and mature; in all cases it is where the growth is soft and immature. Dahlias, of course are quite done for, and nearly every Potato top in the district is killed to the soil. In the case of third early varieties of course this is not a serious matter but a few weeks' more growth for the *Magnums* and *Champions* would have benefited the tubers greatly, especially after the heavy rains we have been having, and we hope our friends in the south have fared somewhat better."

— We learn that THE UNITED HORTICULTURAL BENEFIT AND PROVIDENT SOCIETY will hold a dinner to commemorate its twenty-first anniversary, on Tuesday, October 11th, 1887, at 7.45 P.M., at the "Caledonian" Hotel, Robert Street, Adelphi Terrace, Strand, W.C., Harry Veitch, Esq., in the chair, supported by Mr. R. Dean. Tickets 5s. each. The Committee hope to have the company of as many friends as possible, so that the gathering may be really a success, and of ultimate benefit to the Society. Tickets can be obtained from any member of the Committee and from Mr. H. C. Foll, The Putney Floral and Horticultural Depot, 8, Salisbury Pavement, Putney, and to whom applications must be made not later than October 7th.

— THE fruits or "keys" of *AILANTUS GLANDULOSA* are unusually abundant this year, as they sometimes are after a hot summer, and we recently saw a row of trees in Messrs. Rivers and Son's nursery at Sawbridgeworth that had an exceedingly handsome appearance. Some of the "keys" were of a rich mahogany tint, and all were extremely brightly coloured. A correspondent also writes:—"We have a good specimen of *Ailantus glandulosa* from forty to forty-five years old. This tree flowered freely in July, and is now covered with large bunches of seeds, similar in form to those of the Ash, but of a bright red colour. The effect is beautiful when the sun shines on it."

— MR. H. OSMAN, The Gardens, Harefield, Romsey, remarks that "PLUM MIRABELLE PETITE is a most valuable Plum for preserving, and with us is very free bearing. The tree under notice has been planted about six years, and covers a space of about 16 feet by 8 feet on a wall facing due east, a position which seems to suit it very well indeed, as for the last four years it has produced a very heavy crop, this season being the heaviest of all. Consequently, with that and the drought experienced here, the fruit has been smaller than usual. The fruit has been made into jam, and it has all the appearance of Apricot jam. Therefore anyone having a difficulty in growing Apricots in sufficient quantity for preserving purposes I should recommend to plant this Plum. It never makes much wood with us, therefore requires very little pruning."

— THE EIGHTH ANNUAL CRYPTOGAMIC AND BOTANICAL MEETING OF THE ESSEX FIELD CLUB will be held on Friday and Saturday, the 28th and 29th of October, in Epping Forest. It is intended to devote the Friday to the collecting of specimens of Fungi, their examination and arrangement, and on the Saturday to hold an exhibition of Fungi, fresh and preserved botanical specimens, microscopical objects, drawings, &c., as well as of other objects of natural history likely to interest those present. The named series of the species of Fungi gathered during the two days' hunting in the Forest, which has always proved to be such a valuable and interesting feature at these meetings, will, as before, be kindly arranged by the experts under the direction of Dr. M. C. Cooke. The Exhibition will be opened at about four o'clock on Saturday, October 29th (in the large ball-room attached to the Roebuck Inn, Buckhurst Hill). Ample time will thus be afforded for its inspection by the visitors present, and ample space and all possible facilities will be given to exhibitors.

— HULL AND EAST RIDING CHRYSANTHEMUM SOCIETY.—We are requested to state that from the present date all communications should be addressed to Mr. Edward Harland, Hon. Sec., Manor Street, Hull.

— FROM Mr. T. Laxton, Bedford, come blooms of INVINCIBLE BLUE SWEET PEA, one of the finest varieties of its kind that we have seen. The flowers are of unusual size, of a fine clear blue tint, and their value for cutting will be considerable.

— A PECULIAR POTATO GROWTH.—Messrs. J. Carter & Co., High Holborn, send us tubers of their King of the Russets Potato, which they state were set aside last spring in a box without any covering. In place of the usual sprouts from the eyes they have produced clusters of small tubers, some of which are again developing shoots. At the crown of the tubers there are dense clusters of growths, apparently arrested buds, and amongst these are the secondary tubers of several sizes.

— MR. JOHN ROBERTS, The Gardens, Tan-y-Bwlch, Merionethshire, favours us with some extremely fine DOUBLE NEAPOLITAN VIOLETS, very large, full of excellent colour and fragrant. Packed closely in a tin box they arrived in remarkably fresh condition, and if others of our correspondents who send flowers for naming or for an expression of opinion would adopt this method it would save us some trouble.

— THE WINCHESTER HORTICULTURAL SOCIETY will hold their fifth annual Exhibition of Chrysanthemums, fruits, and flowers on November the 15th and 16th next. A total exceeding £70 will be given in prizes, and we hope there will be the same steady improvement in the Exhibition that has been so noticeable in the past two or three years.

— VIOLET CULTIVATION.—"There are few flowers," says "Juvenis," "which in their cut state are more appreciated by ladies than the modest Violet. It is very easy to have them for at least six months of the year when flowers are as a rule scarcest. We grow ours



along the side of our Rose beds, where they have plenty of room to increase, and they also hide the bareness of the beds in the summer time with their beautiful green foliage. In the month of April we lift the old plants, liberally manure the beds, and fork them. All the young runners with roots are selected and dotted through the beds at a distance of 2 or 3 feet. By the 1st of September they are in full bloom, and they keep on bearing great numbers of deliciously fragrant flowers till the frost becomes very severe. Prior to this, however, some of the best plants have been lifted with good balls of earth attached, and placed along the inside border of an unheated Peach house, where they bloom freely quite unchecked, those left in the open supplying us with blooms during the milder periods and giving us fresh plants in the spring. I may mention that the variety we grow is *Victoria Regina*, which has a particularly hardy constitution."

— THE same correspondent observes, "I quite agree with your correspondent Mr. Murphy regarding the great utility of *ROSE GLOIRE DE DIJON*. We have many plants of this Rose grown for indoor decoration which we struck about two years ago, they being now fine bushy plants in 6-inch pots. Early in spring this year they were covered with blooms and were admired by everyone. After flowering they were deeply plunged in the open ground in their pots, and they did not require a drop of water the whole summer. About three weeks ago they were bushy, numbers of fine healthy buds being upon them, and they are now again in full bloom. I am quite aware there are many Roses with finer blooms, yet for floriferousness, hardiness, and adaptability to circumstances, I do not think there are any to equal the Old Glorie Rose."

— IT is announced that the *ECCLES, PATRICROFT, PENDLETON, AND DISTRICT CHRYSANTHEMUM SHOW* will be held in the Town Hall, Eccles, on Friday and Saturday, November 25th and 26th this year. This Show is the first held in the district, and is under the auspices of the Patricroft Linnean Botanical Society. Prizes are offered in twenty-six classes, ranging from £2 10s. to 2s.

— MR. JOSEPH MALLENDER sends his usual SUMMARY OF METEOROLOGICAL OBSERVATIONS AT HODSOCK PRIORY, WORKSOP, NOTTS, FOR SEPTEMBER, 1887. Mean temperature of the month, 52.4°. Maximum on the 3rd, 67.5°; minimum on the 28th, 30.2°. Maximum in the sun on the 18th, 122.1°; minimum on the grass on the 28th, 25.2°. Mean temperature of the air at 9 A.M., 54.0°. Mean temperature of the soil 1 foot deep, 54.5°. Nights below 32° in shade one, on grass ten. Total duration of sunshine in month, 95.7 hours, or 26 per cent. of possible duration. We had one sunless day. Rainfall total, 1.80 inch. Maximum fall in twenty-four hours on the 14th, 0.29 inch. Rain fell on eighteen days. Wind average velocity, 8.4 miles per hour. Approximate averages for September:—Mean temperature, 55.8°. Rainfall, 2.51 inches. Sunshine (six years), 110 hours. The coldest September for ten years. The deficiency of rainfall since January is about 6½ inches, while the mean temperature for the same period is 1½° below the average.

— MR. W. JUPP, Violet Lane, Duppas Hill, Croydon, sends us flowers of a seedling *WHITE TUBEROUS BEGONIA* remarkable for their size, abundance, good form, and purity. Good varieties of these useful plants are now so numerous that it is not uncommon to obtain several fine forms from a packet of seed, but so many have been named that it is hardly safe to bestow new titles without comparing them with a large collection.

— IF any readers of this Journal have noticed any instances this season of the *DESTRUCTION OF RIPENING GRAPES BY THE CATERPILLARS* of a tortrix (presumed to be *angustiorana*), an entomological correspondent would be glad to have particulars of the attack.

— **GARDENING APPOINTMENT.**—Mr. Frank Orchard, late gardener at Abington Hall, near Cambridge, has been appointed head gardener to John Fraser, Esq, Fleet Leas, Thorpe, near Chertsey.

— **A KENDAL CELERY SHOW.**—Mr. C. A. Lewthwaite, 8, Far Cross Bank, Kendal, sends us the following note:—"I venture to ask you to insert a few remarks on a Show of Celery with special prizes given for Red Cabbages and Spring Onions. The culture of Celery is the all-absorbing occupation of cottage gardeners in Kendal. Celery Shows, and the good and valuable prizes offered, give an impetus to the growth of this valuable vegetable which is quite astonishing. Very

seldom will you find a piece of ground (or even small plots of spare ground which has been considered waste, and in one of the latter cases I have known the first prize carried off in an entry of nearly a hundred), without its rows of Celery with paper collars to guard its tender stems. At the St. George's Temperance Celery Show the entries for Celery numbered seventy-seven. The first prize was awarded to Wm. Troughton, a weaver by occupation, and the stem measured 5 feet long from tip of leaves to the base with the root taken off; its girth was 13½ inches, and it was bleached 2 feet 10 inches in length. Several other competitors showed specimens closely approaching these dimensions. Some Leeks were also shown, not for competition, but out of the same row specimens have been staged twice before this season, and on each occasion won first prize easily, the Judges commending them very highly. On this occasion the largest measured 7½ inches in circumference, were bleached 10 inches, and were much admired. We had also an Autumn Giant Cauliflower which weighed 10 lbs. The Show concluded with a capital tea and concert, which ended a day that is much looked forward to and thoroughly enjoyed."

— "GOOD PEAR FRUITS FROM APPLE STOCKS," writes "F. W. B.," "have often been obtained in America, France, and also in England. In my 'Cultivated Plants,' p. 485, I give all records I could find up to 1875, and they are rather interesting in connection with your note (*Journal of Horticulture*, p. 271). After all, the intergrafting of Pears on Apple stocks is not more wonderful than the case of *Garrya* and *Aucuba*."

— "D. P." considers *SCUTELLARIA MOCCINIANA* "one of the finest of autumn and winter-flowering plants, and it should occupy a position in every stove. When the plants cease flowering remove the dead flowers, which will enable them to break freely. Insert the cuttings in January or February in a mixture of loam, leaf mould, and sand. They will root quickly. Pot them when sufficiently rooted, grow them on in a stove or Cucumber house, and they will make useful flowering plants by autumn—a time when their gay colour is very acceptable. I have found them do well in a Cucumber house, as they delight in abundance of moisture during their season of growth. Pinching must be strictly adhered to at the commencement to form bushy plants, or they soon become drawn and unsightly, but this defect can be easily avoided with proper attention."

— IN reply to "T. H. P.," who inquires respecting the best system of *KEEPING WALNUTS*, Mr. T. Record sends a description of "a plan which has answered very well. If the nuts are ripe they will come out of their shells quite bright and clean, while others which are not ripe should be laid on a mat in the sun for a day or two, when they will split open and shell easily. The cleanest and best samples should be kept separate from the others, but all should be wiped, not washed, before storing, then get some large flower pots—I use No. 1, or the next size—stop the holes at the bottom with clay, then fill with the nuts to within an inch of the rim, lay a piece of brown paper over them, then take them to a south wall or shelter and dig a hole large and deep enough for the pot to go 6 inches below the surface, then cover securely with a large piece of slate or seasoned board, covering it with earth, banking it against the wall so as to throw off the wet, heating it firm with the spade. In this way I have found them keep fresh and sweet without the kernel wasting in the least degree. When any are required for use take out what are wanted a few hours previously, wipe them with a cloth and let them dry."

#### GARDENERS' ORPHAN FUND.

At a meeting of the Executive Committee held on Friday last, George Deal, Esq., in the chair, the following, who have accepted office as Honorary Local Secretaries, were appointed for the various districts in which they are resident. A sub-Committee was appointed to select Local Secretaries for Ireland, Scotland, and Wales. Several applications for the benefits of the "Fund" have already been received.

Several of the trade wrote making proposals for the distribution of circulars with regard to the fund in their catalogues, which the Committee highly approved of, and the Hon. Secretary, Mr. A. F. Barron, R.H.S. Gardens, Chiswick, will be pleased to receive the names of others.

*Bedfordshire.*—Mr. Empson, Ampthill House Gardens, Ampthill.  
*Berkshire.*—Mr. C. Howe, Benham Park Gardens, Newbury; Mr. J. H. Rose, Lockinge Gardens, Wantage.  
*Buckinghamshire.*—Mr. G. T. Miles, Wycombe Abbey Gardens, High Wycombe.

*Cambridgeshire*—Mr. J. Taylor, Sefton Park Gardens, Newmarket.  
*Cheshire*—Mr. J. Atkins, Tatton Park Gardens, Knutsford.  
*Derbyshire*—Mr. J. H. Goodaere, Elvaston Castle Gardens, Derby ; Mr. W. Bennett, Rangemore Gardens, Burton-on-Trent ; Mr. G. Bolas, Hopton Hall Gardens, Wirksworth.  
*Devonshire*—Mr. Peter Veitch, Royal Nurseries, Exeter ; Mr. D. C. Powell, Powd rham Castle Gardens, Kenton ; Mr. G. Baker, Membland Hall Gardens, Ivybridge ; Mr. W. Napper, Messrs. Lucombe, Pince, and Co., The Nurseries, Exeter.  
*Dorsetshire*—Mr. T. Denny, Down House Gardens, Blandford.  
*Essex*—Mr. S. Coulter, Copt Hall Gardens, Epping.  
*Gloucestershire*—Mr. W. Foster, nurseryman, Stroud.  
*Hampshire*—Mr. W. Wildsmith, Heckfield Place Gardens, Winchfield ; Mr. W. Earp, Hume Tower Gardens, Bournemouth ; Mr. G. H. Richards, Soberley Gardens, Ringwood.  
*Herefordshire*—Mr. W. Coleman, Eastnor Castle Gardens, Ledbury ; Mr. C. Denning, Holme Lacy Gardens, Hereford.  
*Hertfordshire*—Mr. J. C. Mundell, Moor Park Gardens, Rickmansworth.  
*Kent*—Mr. R. Cannell, The Nurseries, Swanley ; Mr. F. Miller, Northdown Park Gardens, Margate.  
*Lancashire*—Mr. Atherton, Fern Bank Gardens, Cadley ; Mr. Goldby, Walton's Nursery, Burnley.  
*Lincolnshire*—Mr. D. Lumsden, Bloxholm Hill Gardens, Sleaford ; Mr. H. Divers, Ketton Hall Gardens, Stamford.  
*Norfolk*—Mr. S. Castle, West Lynn, King's Lynn ; Mr. C. Penny, Sandringham Gardens, King's Lynn.  
*Northamptonshire*—Mr. H. Birch, Castle Ashby Gardens.  
*Somersetshire*—Mr. J. C. Clarke, Cothelstone House Gardens, Taunton ; Mr. J. H. Vallance, Redland Lodge Gardens, Bristol ; Mr. W. Iggulden, Marston Gardens, Frome ; Mr. J. Ellicott, Crowe Hall Gardens, Bath.  
*Suffolk*—Mr. D. T. Fish, Hardwick House Gardens, Bury St. Edmunds ; Mr. W. Low, Euston Hall Gardens, Thetford ; Mr. J. Bole, Somerleyton Hall Gardens, Lowestoft.  
*Staffordshire*—Mr. J. Udale, Elford Hall Gardens, Tamworth.  
*Surrey*—Mr. H. Appleby, Boxhill Nursery, Dorking ; Mr. J. Burnett, The Deepdene Gardens, Dorking ; Mr. G. W. Cummins, The Grange Gardens, Wallington ; Mr. F. Ross, Pendell Court Gardens, Bletchingley ; Mr. W. G. Head, Crystal Palace, Sydenham.  
*Sussex*—Mr. A. J. Brown, The Lodge, Finches, Lindfield.  
*Warwickshire*—Mr. R. Greenfield, Priory Gardens, Warwick.  
*Westmoreland*—Mr. W. A. Miller, Underley Hall Gardens, Kirkby Lonsdale.  
*Wiltshire*—Mr. H. W. Ward, Longford Castle Gardens, Salisbury ; Mr. A. Read, Grittleton House Gardens, Chippenham.  
*Worcestershire*—Mr. W. Cramp, Malresfield Court Gardens, Great Malvern ; Mr. J. Austen, Witley Court Gardens, Stourport.  
*Yorkshire*—Mr. H. J. Clayton, Grimston Park Gardens, Tadcaster ; Mr. R. Scott, Moorfield Gardens, Manningham, Bradford ; Mr. G. Hemming, Allerton Hall Gardens, Leeds ; Mr. E. Austen, Browville House Gardens, Sheffield.

### EXHIBITS AND JUDGING.

It was generally understood hereabouts that the £50 given by the Durham and Northumberland Horticultural Society Committee was in honour of Her Majesty's Jubilee, and not at all to be taken as a precedent to be followed in the future. Being honoured by three such good men entering and contesting, the gentlemen who so ably represent this flourishing Society made it no secret that they considered themselves amply justified and compensated for their loyal venture. The prize was a special one for a very special occasion. The same schedule offering four and five prizes for ordinary exhibits, undoubtedly shows the opinion of the Committee, allowing the exhibitor more latitude in the choice of the exhibits he may set up, and lengthening the prize list, to give to all who exhibit worthily a reasonable chance of securing a prize, are generally the changes that are necessary to secure more successful exhibitions.

The twenty bunches of Grapes at the Crystal Palace being also a speciality, it may be counted as certain that there would have been a special competition, but it is an old arrangement, hitherto faulty, and ought now to be considered as dead. The Edinburgh prize for "six black and six white" is also too restricted. Twelve bunches, not less than six varieties, would be an arrangement likely to secure greater success.

As to judging. Has the time not arrived when judging cards, such as I suggested a few years ago, might be brought into use? By a rough glance through Mr. Hunter's and Mr. McIndoe's Jubilee exhibits, I, on the principle then suggested, made out the former 249 and the latter 220 points. My wonder was, how but by point judging had the decision been arrived at? I hold no hard-and-fast ideas, but some such change I contend, is most necessary. Next, just a word, Cannot your correspondents moderate their comments and criticisms?—JOSEPH WITHERSPOON

MR. WARD'S experience would surely teach him better than to send such "worthless exhibits," as some of your correspondents would have us believe, to such a show as the Crystal Palace, where the keenest competition might be expected. The first prizes there are anything but extravagant, and the third not remunerative enough to entice anyone from a long distance, and that ought to be quite sufficient to show that

Mr. Ward has been unfairly treated. It is quite optional, as a matter of course, whether Mr. Ward exhibits again at the Palace, but before he does so I hope the exhibits will be simply numbered the same as they are at many other shows, as the present Palace system is not quite satisfactory. We have, in last week's Journal, advice from the north, and we wish some of our northern friends would venture south more frequently with their productions. Northern exhibits that I have seen are often deficient in quality, and, as an instance, I may state that both the Veitch medals were awarded to exhibits quite unfit for table, at the Edinburgh Show, a few years ago, and Mr. Barron did not ask the winners about sending their exhibits to their employer's table.—R. M.

### STABLE MANURE.

WE cannot help thinking, judging from what we frequently see, that much stable manure, both in the gardens of the rich and of those not so well to do, is not much better than wasted. I am aware that I may be taken to task here, for I remember reading some years ago that "nothing was wasted." Nevertheless I assert that in many cases much of the valuable nitrogen in the form of ammonia is dissipated, and to the cultivator is practically lost.

Where there is no other than stable manure, as is often the case, it is by no means an easy matter to prevent this loss, for we all know the tendency it has to become violently heated, when of course the loss takes place, dry rot immediately sets in, and in a few days what might have been valuable manure is only so much dry straw or litter scarcely worth removal. In all cases where manure of this kind is kept there should be a good brick and cement tank constructed to hold the liquid portion of the manure, a portion of which should each morning be sprinkled over the fresh manure. This is a matter which needs particular and daily attention ; any haphazard slovenly manner in dealing with this will only result in such a condition as described.

In our case we always endeavour to keep a portion of old manure in one half of the space allotted to our manure heap, the other half being set apart for the fresh manure which comes from the stable every morning. The new is shaken out and evenly distributed, and then a layer of the old shaken upon the top and the whole sprinkled with water from the cesspool beneath. It has often surprised me to find in what a short time this will become a heap of valuable manure for any purpose. As this is a very valuable article with us, as well as many besides, we are careful to have every particle of vegetable matter thrown on this heap, as well as old potting soil and night soil, &c., which were formerly kept separate from the manure heap, but which now we think are more profitably used mixed together.

The drainings from this heap we value very much, as upon this we have to depend for all the liquid manure that we get. We would much prefer to have the drainings from the cow and pig houses into this tank, but in our case this is quite impracticable. Of course in cases where manure from the cow house is mixed with the stable manure the heating will not be so violent and the heap altogether easier to manage.

How often manure heaps in and near towns which are often a public nuisance and danger, if managed a little more after the manner described might be made much more profitable as well as less objectionable. It is surprising how much ignorance we meet with in matters of this kind. Quite recently we were endeavouring to persuade a horsekeeper of the desirability of thus attending to the manure if he would profit by it. He coolly said it did not pay him to bother with it, as he had no difficulty in securing a good price for it even if it was dry, as the purchasers reckoned it would "do for taties."—WM. JENKINS.

### TRANSPLANTING AND ROOT-PRUNING FRUIT TREES.

THE prevailing idea is that planting and root-pruning are operations that should be carried out during the winter season. There appears also to be a vague idea that there is more time than for such matters than during any other period. If this was really a fact there would be some grounds for the entertainment of such views. Such, however, is not the case, for there is in all gardens less demanding urgent attention after the fruit has been stored than after the foliage has fallen.

If this matter is examined carefully we shall find that if transplanting is not started and brought to a close early in the season it is generally of necessity left until January. How often is the work still farther delayed by several weeks' frost, and thus it is carried out during the following month or postponed altogether. The labour required to keep most gardens tidy often prevents

Other work being pushed forward rapidly. When the leaves have fallen a general clearing up is needed, which in a good many places takes until Christmas, then the kitchen garden needs digging, walks turning, and many other matters require attention. Root-pruning must be done early in the season before the foliage falls, when the weather is good and the land in the most satisfactory condition. The last is a matter of importance and cannot be ignored, for we invariably find it in any but a satisfactory condition, even in November, and is very frequently worse one or two months later. Trees or plants do not start away well when the ground is trodden and worked about their roots in a wet condition. When transplanting is done early before the foliage falls the trees have every chance to make a few fresh roots and thus become partially established before the approach of winter. Not only can the work be done better and easier, but there is no comparison between the growth of trees the following season that have been transplanted early and those that have been left two or three months later. These are not the only advantages, for the fruit garden is ready for clearing directly the leaves have fallen, say two months earlier than can possibly be the case when this work is left until the approach of winter before it is attempted.

It is concluded, of course, that early pruning is practised, which is of equal importance with the early system of transplanting and root-pruning. I have repeatedly urged the necessity of doing this work while the weather is warm and genial, not only from an economical point of view, but also for the well-being of the trees and the prospect of a good crop of fruit the following year. Pruning as soon as the fruit has been gathered, or as it is gathered, cannot well be too strongly or too frequently urged, when we see in many gardens such waste of the energies of the tree. Light and sunshine are prevented from reaching those parts that most need it, the few weeks left to the trees to perfect their work being spent on material that is useless and eventually to be cut away. All useless shoots and branches should be removed directly the fruit has been gathered, so that the whole energies of the trees can be concentrated upon the development and perfection of the fruit buds. If more attention was paid to this highly important matter, planting and root-pruning being done earlier, we should soon perceive rapid progress in the culture of hardy fruits.

The best time in my opinion for transplanting and root-pruning is during the present month. The work can be commenced directly the fruit is gathered from the trees; in fact it need not be delayed until the whole has been gathered, but the two operations can be going on at the same time, commencing with those from which the fruit has been taken first, and finishing with trees that have to be purchased from a nursery. Planting takes but little time provided the ground has been previously prepared for the reception of the trees. Delay in planting results in many instances from lack of forethought, and the ground is left until the trees arrive before an attempt is made to prepare it. My advice is to those who have deferred this as winter's work to set about the preparation of the ground at once, and I venture to predict that they will not return to the general system, one that should have been obsolete long ago.

It may be argued that root-pruning is a waste of time, and only betokens mismanagement of the branches. To dispense with pruning the branches as well as the roots means following a natural system, or what some call "extension," or in other quarters the "letting alone" principle. This system may have advantages, but it also has disadvantages that cannot be ignored. It is, however, no part of my present duty to examine this mode of culture; suffice it to say that trees grown on these principles are not suitable for all positions. They have a straggling appearance when their branches are weighed in all directions by carrying a crop of fruit, which in a few years results in fruit of moderate size only.

When trees have to be restricted, as thousands have, in gardens of nearly all sizes, pruning the branches and roots is necessary to keep the trees within bounds and in a healthy fruitful condition. They can certainly be managed without either, which is the result of cropping them until they become a mass of fruit spurs. Trees in this condition are not desirable for a few years means decreased vigour and puny fruit, which, if they are to be restored, must be subjected to a rather severe system of pruning. Root-pruning, as some understand and teach, consists in digging up the trees, shaking the whole of the soil from the roots, cutting them severely back, and then replanting in the same position. The system I advise is a moderate one, to be practised at intervals of two, three, or more years, according to circumstances. It consists in digging a trench round the trees and shortening roots that are taking the lead and causing the tree to grow too luxuriantly to be fruitful. If this is done periodically after the trees have been planted (say three years) it insures their making abundance of fibry roots and very few of the strong useless ones that are formed when a haphazard system of

root-pruning is adopted, and which is the result of leaving the tree alone too long after planting. The more the trees are dug round the more fibry their roots become, and the check they receive if they have to be transplanted is considerably less. Trees that have been root-pruned at given intervals can be removed without crippling them seriously, but not so a tree that has been neglected and only possesses long strong fibreless roots. Trees in this condition are crippled and the crop lost for one year at least, and the second season they are often puny and small. Trees that have been subjected to root-pruning only need digging round them, and the few roots cutting back to the edge of the ball and then filling with soil again. It is a simple system that takes up but little time and is sufficient to check the exuberant growth of the trees rendering them fruitful without proving too severe, and thus interfere with the plant swelling its fruit to a large size. Trees in good fertile soil will produce fruit equally as large as they did the previous season, but the growth will only be of moderate strength, which is necessary under all circumstances in order to sustain the trees in health and ensure their fruit swelling to good size.

Trees that have become a mass of fruiting spurs and to all appearance need neither pruning at their branches nor their roots will, if left alone, fruit themselves to death or until they are so weak as to produce fruit that is worthless. The spurs or trees of this description should be cut back freely, thoroughly thinned, and the whole near the extremity of the shoots cut back. This will induce the formation of new growth. If the tree has become very feeble it must be rather severely pruned. A trench must be dug round it sufficiently far from the stem not to cut the roots, a portion of the soil should be worked from amongst the roots and then laid amongst a little fresh soil. Old potting soil, the soil removed from the surface of Vine and Peach borders, or that in which Melons and Cucumbers have been grown, will do very well. Any tree that is declining in vigour should be treated in this manner, and it is surprising how soon they are again restored to health and vigour and capable of yielding fine fruit annually. It must be remembered that if a tree is to produce good fruit it is necessary for it annually to produce a moderate growth of wood, by which means only can the activity of the roots be ensured.

If trees have the fruit thinned annually, are branch and root pruned, if they need it, as soon as the fruit has been gathered they seldom fail to produce fruit annually, and when they do failure is due to the ungenial weather when the flowers expand. Even in the north they do not appear to fail half so frequently as many people's trees do in more favoured spots from this cause. The weather is too often blamed when failure is due to other causes, which could often be overcome by a better and more judicious system of culture.  
—WM. BARDNEY.

#### VIOLAS.

I HAVE read with great interest Messrs. Jenkins and Dean's practical remarks on the culture of this now popular flower, and I was anxiously looking forward last week to see if anyone else would give us the benefit of their experience. As Mr. Dean truly says, it has taken some time to write the Viola into popularity, but when we see such men as Downie, Dobbie, and Lister taking it up, we may feel sure there is an increasing demand for exhibition varieties. Mr. Jenkins and Mr. Dean as large growers will no doubt have everything at their command, but what about the amateur, who, although on a small scale, likes to have his blooms up to exhibition form, and cannot always get good cow manure, old Cucumber beds, or decayed turf from an old pasture as some recommend? I have had several good receipts on the secret of growing Pansies sent me, but they all require a great deal of unnecessary labour. What the amateur wants is a method as simple as possible, and one that does not demand much labour or expense. I will therefore give a few particulars on the mode of treatment mine have received with marked success. The particulars of my culture are taken from the advice of Mr. John Downie to an old florist friend of mine some time ago. Last year I had put myself to some trouble and expense in preparing my bed, and purchased some very fine varieties which I planted in April. They did very well for a time; however, as the season advanced one after another showed signs of going off. I was therefore obliged to take most of them up and place them in a shady border to save them. My friend happening to come past at the time and hearing my sad tale, asked me to try Mr. Downie's plan, and plant them on a piece of ground after Potatoes. Accordingly a piece which had been well manured for the Potatoes was chosen and dug in the autumn. A little soot was thrown over it and allowed to get well pulverised with the frost. The ground was forked over a few times during the winter, the bed squared up and planted in April, with the result that I have not lost a single variety. Of course during the dry weather I kept them damp, and gave them a little liquid manure on two or three occasions, but I must also endorse what Mr. Dean says about deep planting, as I have experienced the benefit of it this year.

I grow about fifty varieties, but the following are the most robust growers:—Duchess of Albany, Unique, Mrs. J. Cowan, Archie Grant, Bullion, Mrs. Steel, The Mearns, Pantaloon, Clipper, Duchess of Suther-



land, Mrs. Baxter, Mont Blanc, Countess of Kintore, Ethel Baxter, Abercorn, Beauty, Columbine, Crown Jewel, and Queen El-anor. With regard to the newer varieties I cannot say much for Ethel Baxter, of which Mr. Dean seems to think so much; it has a good constitution and habit, but these, I think, are her only recommendations. Mrs. Baxter is a very fine variety and a robust grower. I am pleased to say I have a good companion for it in a seedling I raised last year. I shall send Mr. Dean blooms of it, and perhaps we may hear his opinion by-and-by.

Now, I wish to ask a question or two, which perhaps some of your correspondents will kindly answer. First, What are the characteristics of a Viola? Secondly, What is the difference between a Viola and a Pansy? I have put this question to several gardeners, but have never had a definite answer. I have also seen the question asked in different gardening journals, but never answered to the point. Now, I think it is time we had a line drawn, as so many different fancy Pansies are being introduced which will be classed among the Violas as bedding Pansies. Now, I hold that if a prize is given for say six or twelve Violas, Violas ought to be staged, and any stand containing any of these bedding Pansies ought to be disqualified. I remember at the Pansy Show in Edinburgh two years ago asking a gentleman, a noted florist, and a judge, too, why he classed Merchiston Castle with the Violas. His reply was, "Man, she's sae bonny we canna set her aside." If these are the lines we are to go by, where shall we end? We have the characteristics of a Pansy clearly defined, let us also have that of the Viola. When these questions are answered I may perhaps have something more to say on this useful flower.—G. STEEL.

### ALNWICK CASTLE.

NORTHUMBERLAND'S county town of Alnwick, which for hundreds of years in the troublous times of the Border feuds was the scene of continual strife, and one of the most important of the northern strongholds, is now a quiet country town, interesting for its antiquities and history, famous for its grand old castle, and an agreeable resort for tourists who wish to spend some time in the pleasant district surrounding it. Traces of ancient British and Roman inhabitants are found, but it appears to have been a Saxon town at the time of the Norman invasion. For a period subsequent to that event it was identified with the De Vesey family, and since then for five centuries its history has been practically that of the noble Percy family. Though some modernisation has taken place the antiquary can still find abundance to study both in and around the town, as ruins of abbeys, priories, and other buildings are numerous in several directions, and afford ample food for reflection. One of the old gates, the Bondgate, still remains entire, but the walls have disappeared together with many of the ancient buildings, the peculiar customs and ceremonies, which gave such a distinctive character to the place in past years. The visitor arriving by train from Bilton Junction, a short branch of the North-Eastern mainline, three or four miles in length, now finds a spacious station, a new line connecting it with Coldstream having recently been opened, and enters the town by a pleasant tree-shaded road, more suggestive of some modern continental resort than a secluded Northumbrian town with a history of so many hundred years. Proceeding towards the Castle the lofty "Tenantry Column" is noticed on the right, situated on a mound and surrounded by a small public garden, maintained at the expense of the Duke of Northumberland. This column was erected seventy years since to commemorate the second Duke's liberality in remitting a large portion of his rents at a time of severe depression, and as it cost some £3000 it has also gained the local name of the "Farmers' Folly," as proving how little their landlord's generosity was needed. It may, however, also be regarded as an instance of gratitude that is probably unique. A few minutes' walk from there and the entrance to the Castle gardens is reached, close to the Old Bondgate, and as that is our destination we leave the town to place ourselves under the charge of the Duke of Northumberland's able and energetic gardener, Mr. George Harris.

Alnwick Castle is one of the grandest of the old baronial strongholds to be found in the kingdom, and though little of the original building remains, its characters are practically unaltered, as renewal or repairing has been conducted most carefully. At the time of the Conquest a chief named Tyson is said to have been the lord of Alnwick, then for three hundred years it remained in the possession of the De Vesey family. The Castle and barony were purchased by Henry de Percy in 1309, and for a period of three centuries this family was one of the most powerful in the country, its members being famed for their valour in the innumerable conflicts of the time, one of which has been celebrated in the ballad "Chevy Chase." The Earldom of Northumberland was created in 1377, and the Dukedom in 1766, the present possessor of the title being the sixth Duke. Speaking of the Percys, Burke says, "Not more famous in arms than distinguished for its alliances, the house of Percy stands pre-eminent for the number and rank of the families which are represented by the present Duke of Northumberland, whose banner consequently exhibits an assemblage of nearly nine hundred armorial ensigns, among which are those of King Henry VII., of several younger branches of blood royal; of the sovereign houses of France, Castile, Leon, and Scotland; and of the ducal houses of Normandy and Brittany, forming a galaxy of heraldic honours altogether unparalleled."

During the life of the fourth Duke, "Algernon the Magnificent," as he was known in the north, the restoration of the Castle was undertaken, and it is said that in a period of ten years £300,000 were expended.

Certainly the work was performed in a princely manner, and the superb apartments, with their elaborate carvings, tastefully decorated ceilings, palatial stone staircase, with the library of 15,000 volumes, constitute it a residence literally "fit for a king." The massive walls and defensive resources also indicate that its strength in the feudal ages was equally as remarkable as its internal grandeur is at the present time. Situated, too, upon elevated ground above the river Alne, it commands a beautiful view of the park and gardens, and from a point on the opposite side of the river, termed Barbara Bank, the photograph was taken from which the illustration (fig. 38) was prepared.

### THE GARDENS.

But we must return to the garden, where there is much to be noted of more special interest to Journal readers. As might be expected, the requirements of such an establishment are very large, and to meet them the garden must be proportionate both in size and conveniences. This is not only found to be the case, but its general condition and thoroughly practical system of management are in perfect accordance with its reputation. As to the demands sometimes made upon its resources, it may be stated that as many as 1600 persons have dined in the Castle in one day, but this was a very special occasion (the coming of age of Lord Percy), and then both the experienced *chef de cuisine*, Mr. Thorpe, and the gardens were severely taxed. The kitchen and flower gardens are some distance to the east of the Castle, the greater portion enclosed within substantial walls 12 to 14 feet high, and slightly sloping northwards or towards the river, but well elevated above it. This is rather unusual, but there are portions with warmer slopes that can be utilised for the earlier crops, and late supplies are principally required at Alnwick. The majority of the glass houses are situated in a large quad-

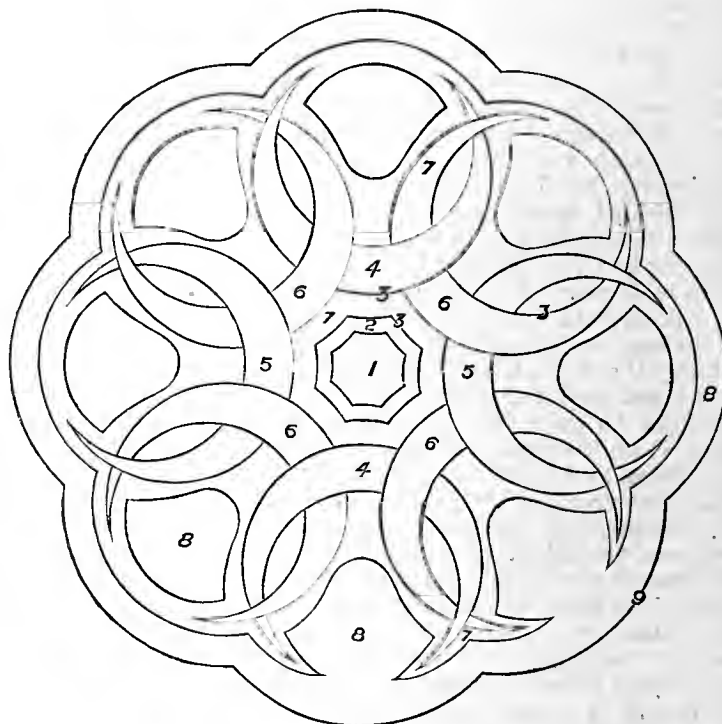

Fig. 37.—A Bed of Hollies.

angular space near the gardener's house at the lower portion of the ground, the flower garden and remarkable Holly beds occupying the upper part, which communicates with the chief division of the kitchen garden by ornamental iron gates. At the lowest part of the ground is the conservatory, a spacious building 120 feet long, 26 feet wide, and 30 feet high, which is filled with a number of useful flowering plants. There a series of iron pillars at the sides of the broad central paths supporting the roof, and upon these are trained free growing and free flowering plants that have a very pleasing effect. The fragrant *Luculia gratissima*, for instance, seems to be thoroughly at home; it is in perfect health, is 12 feet high, and flowers most abundantly every season. *Fuchsia corallina* is another very beautiful plant on one of these pillars, and though only three years old it is 20 feet high and was loaded with flowers. The white *Lapageria*, *Habrothamnus elegans*, *Plumbago capensis*, *Clanthus puniceus*, and *Abutilon Boule de Neige* are trained in a similar way, forming quite a floral avenue, while *Solanum jasminoides* hangs in long festoons from the roof. Amongst the miscellaneous plants in pots the *Francoas* were conspicuous at the time of my visit, *Camellias*, *Dracenas*, *Dicksonias*, and *Rhododendrons*. One specimen of the useful *R. Countess of Haddington* 8 feet high in vigorous health is an admirable example of this handsome *Rhododendron*. A *Dicksonia antarctica*, with a stem 5 feet high, has a wonderful crown of fronds, and much of its success is attributed to the practice of watering the stem freely.

### FRUIT HOUSES.

Parallel with the conservatory, about the centre of the flower garden, are two ranges of houses, one on each side, lean-to's with curved roofs. Upon the left-hand side are the vineries, 150 feet long, in three divisions, and upon the other side are the Peach houses of the same length. Vines

are well grown at Alnwick, and by means of a process of renovating old specimens, or planting young, the houses are now filled with healthy fruitful Vines, of which Mr. Harris may well be proud. Several of the best varieties are grown, Black Hamburgh and Muscat of Alexandria being first favourites, and fine bunches of both are produced. The Muscats are an especial feature, capital bunches being obtained weighing from 4 to 6 lbs. each, and these from cut-down Vines. Some young Vines, two years planted, are thriving well, making fine rods that in a year or two will give some substantial results. Mrs. Pince, Lady Downe's, Alicante, and Trebbiano are the other leading varieties, all being extremely good, the first-named unusually so. In the Peach houses are some fine old trees, several perhaps exceeding fifty years in age, and one tree of Royal George, I think, has its stem over a foot in diameter at the juncture of the stock and scion, yet this has had 300 fruits in one season, and is in good health now. Violette Hâtive, in the same division, is also of great size, similarly vigorous and fruitful. The second division con-

Red affording the principal crops of the latter. Out of doors Earliest of All has proved not only the earliest but the most prolific cropper, as the other cultivators have found. Mushrooms are grown extensively, and a large house is appropriated to this purpose filled with four tiers of iron stages each 9 inches deep, so that a very moderate amount of manure and soil is required on each bed. Care is exercised in procuring good spawn, and plentiful crops are obtained throughout the greater portion of the year. In the plant houses, of which there are several, for the propagation and culture of decorative plants, table plants, Ferns, &c., is a fine stock of healthy little specimens, Ferns and Palms being uncommonly well grown. Calanthes are similarly successful, and a plant that is much valued is the Otaheite Orange. Numbers of these are grown in 48 and 32-size pots, and when bearing twenty or more small brightly coloured fruits they have a very ornamental appearance. The cuttings are struck in spring, this variety being really increased by this means, and in two years compact bushy little specimens in 32-size pots are secured which

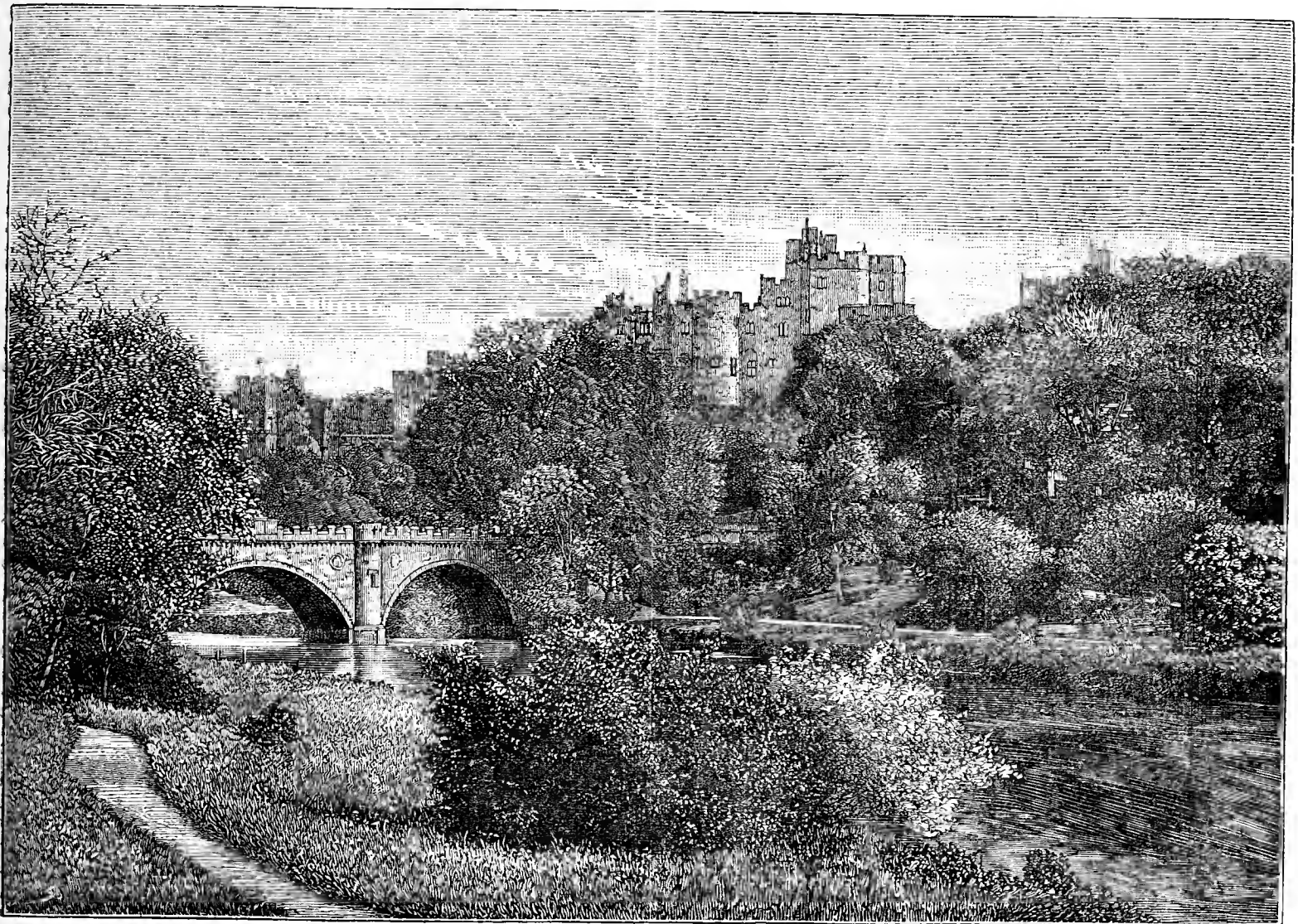

Fig. 38.—ALNWICK CASTLE.

tains some younger trees, and others that have been lifted, the borders drained, and their condition correspondingly improved. A specimen of Royal George, two years planted, is making good progress; Pineapple Nectarine is a favourite, and does well. Barrington has had a magnificent crop, some of the fruits weighing 11 ozs., and Prince of Wales is much appreciated as a late variety, bearing a large crop of fine, good-flavoured fruits. In the third division, Late Admirable Peach, Elruge, Violette Hâtive, and Hunt's Tawny Nectarines, are surprisingly prolific, from ten to fifteen dozen fruits having been gathered daily.

Numerous other houses are devoted to fruit and plants. Pines occupy several houses and pits, about 400 fruiting plants being grown every year. Queens, Smooth Cayenne, Charlotte Rothschild, with a few Black Jamaica and Lambton Castle, are the varieties, and fine even fruits are obtained of each, the two first named being mainly relied upon. Melons are in much demand, and a long succession of fruits are obtained from La Favourite, Victory of Bristol, Read's Scarlet Flesh, and Longleaf Perfection, some of the latter weighing 6½ lbs., and the variety is valued highly for its fine quality and excellent flavour. The plants are grown in pots, several crops being obtained from the same plants, by liberal treatment and encouragement of fresh growth. Cucumbers and Tomatoes are also largely grown, Earliest of All, Hackwood Park, and the Old

ripen their fruits by Christmas time, and are then most useful for many purposes.

FLOWER GARDEN AND HOLLY BEDS.

The flower garden, as previously stated, extends from the conservatory up to the kitchen garden wall, the principal beds and borders being formed in four large oblong grass lawns, with broad paths up the centre and across at right angles. Facing the conservatory at the end of the central path is a fountain or pool of water surrounded by masonry, and above this is a steep slope with a scroll in Box and large masses of variegated Hollies, Laurels, and Mahonias arranged in festoon-shaped beds on the banks at the side. Hypericum calycinum also covers a large space on the bank, having been established in a sandy soil, where little else would thrive. The central portion of this slope is occupied with an uncommon and effective design representing the Ducal badge of the crescent, interlaced in small closely clipped Hollies. The plan of this design is shown in fig. 37 greatly reduced, the entire circle being 72 feet in diameter. In the centre (1) is a specimen plant of the Golden Queen Holly surrounded by a neat edge of the small-leaved Wood Ivy (2), and common Box (3), which also forms the defining line to the crescents, as marked in the plan. The latter are planted with Hollies as follows;—In opposite pairs, 4, 4, with Golden Queen; 5, 5, with



Silver Queen; the other four (6) with scotica, a very hardy deep green variety. The central space (7) and the spaces between the horns of the crescent are filled with small white stone chippings, which brings the whole design into bold relief, the spaces (8) occupied with grass neatly kept having the same effect. The Holly has been planted for twelve years, but by frequent clipping and close attention it is kept down to a uniform height of 9 inches, forming compact beds that colour well. The whole is margined with a cement composition (9), giving a neat finish to the design, which is of an exceedingly uncommon character, and presents an idea that with various modifications to adapt it to particular situations might be followed in many gardens.

From the higher ground near the Holly bed a good view is obtained of the flower beds on the lower level, and early in September the effect was excellent. No attempt is made to produce formal designs, but mixed beds of several suitable plants are freely introduced. In the chief beds a dwarf pure white Antirrhinum is largely employed for lines, and a remarkably fine variety it is, surpassing in general effect the best of the white Zonal Pelargoniums. It has been grown at Alnwick for a number of years, and is valued highly. Henry Jacoby Pelargonium is relied upon for richness of colour, and very satisfactory it is in contrast with the Antirrhinums, white or blue Lobelias, Verbenas, or Golden Pyrethrum. Mixed beds of Purple King Verbena and variegated Pelargoniums with a few Fuchsias were attractive, as also were some of purple and white Violas. A central carpet bed of pretty design deserves notice; it is a circle nearly 20 feet in diameter, the groundwork of Oxalis corniculata rubra, with interlacing lines of Mentha Pulegium gibraltarica, Herniaria glabra and Antennaria tomentosa, with a centre of blue Lobelias and a Dracena australis, and angles or various shaped spaces of Sedum glaucum, and Mesembryanthemum cordifolium variegatum, edged with Pyrethrum selaginoides, and dotted here and there with Echeverias and Sempervivum. The variegated Gazania splendens is used as broad bands in several beds and is very useful, its brilliantly coloured flowers contrasting well with the foliage. Interesting borders of hardy plants are also formed, Carnations, Pentstemons, Ast-ers, and many others being largely grown of the best strains. Roses also succeed well, and the collection comprises most of the leading garden varieties. To the right of the Holly slope is a lawn tennis or croquet lawn, which was originally surrounded by a double line of Lime trees to form a kind of avenue; the branches of these have now been bent down at right angles and trained over the path, so that a leafy tunnel or corridor has been formed, affording a pleasant shaded retreat for tired players.

#### FRUIT TREES AND KITCHEN GARDEN.

The wall space devoted to fruit trees is very extensive, and fine specimens Apricots, Peaches, Plums, Cherries, and Pears are numerous. On one of the walls at the lower part of the flower garden, about 12 feet high, with a south aspect, are some capital Apricot trees, that both for health and abundance of fine fruits could scarcely be surpassed. An example of Moorpark twenty-five years old covers a space 30 feet long, and is in perfect health with a large crop. Another lifted last year is not quite so old, but is similarly satisfactory. Several other fine trees are trained to walls in the kitchen garden, one covering a space 20 feet long by 14 feet high, and in vigorous health. These Apricots remind me of some trees I saw a year or two since in Perthshire, at Dupplin Castle and elsewhere, but it is seldom that they are found so free from disease in southern gardens. Peaches and Nectarines also succeed out of doors on the walls, but they give better results under glass. Jefferson is found to be a reliable variety here, and some large old trees give a beautiful crop; Golden Gage also seldom fails. Prince of Wales, Victoria, Coe's Golden Drop, and Kirke's are also included in the collection. Mayduke and Morello Cherries are grown largely with invariable good results. The Pears comprise Louise Bonne of Jersey, Beurré Clairgeau, Pitmaster Duchess, Marie Louise, Beurré Rance, Easter Beurré, Beurré Colmar, which crops very heavily; Beurré Superfin, Knight's Monarch, much valued; Flemish Bon Chretien, a most prolific variety and found to be one of the best kitchen Pears in this district, and Chaumontel, which, however, does not ripen well. Most of those named are represented by large trees, evenly trained and closely spurred, but they give a large return for the labour and attention required. The Apples are mostly as standard bush trees or espaliers, and the most reliable varieties are Lord Suffield, Keswick Codlin, Ecklinville, Pott's Seedling, Cellini, Duchess of Oldenburgh, and Devonshire Quarrenden, which ripens well, and Ribston Pippin against a wall affords a useful supply of fruits.

In the kitchen garden quarters are devoted to Gooseberries, and there was a large quantity of Warrington and Glanton Green carefully netted over for late use, Currants being treated in a similar way. The principal Strawberries are Sir Joseph Paxton, President, Vicomtesse Hericart de Thury, and Marshal Macmahon. Vegetables are grown extensively, Cabbages, Brussels Sprouts, Carrots, Onions, and similar crops occupying considerable space. Where ground is intended for Onions Mr. Harris employs a dressing of gas lime and salt at the rate of about a barrowload to 15 square yards, or just sufficient to sprinkle the surface, applied in the winter after being spread out some weeks before to lose its most violent properties. A mixture of soot, salt, and gas lime in small quantities after a suitable preparation is also useful for ground intended for several other root crops, such as Carrots. One distinguishing character of all the vegetable quarters was their cleanliness and freedom from weeds, and another was that it was evident the drought had not been so keenly felt there as in the south, as shown by the freshness of the crops.

#### THE ARBORETUM.

Outside the walls, on the slopes leading to the river, an arboretum was commenced some years ago, and several specimens have now attained good size and handsome proportions. One of the best modes of establishing tender Conifers, however, is to provide efficient protection for them when young, and several instances are noticeable at Alnwick, where protected trees have far outstripped others of the same kind in more exposed positions. Pinus austriaca Mr. Harris commends very highly as a "nurse" tree, and his experience agrees with that of many other planters in northern districts. A group of flourishing Deodars in sheltered corner form a very beautiful feature in the grounds, and there are some handsome examples of Abies magnifica, A. nobilis, A. Veitchii, 6 feet high, and never injured by frost. A lasiocarpa is also in fine condition where protected from the winds; one example sheltered by a large Beech is 30 feet high, and specimen of A. grandis of the same height has a spread of branches of 15 feet—a finely proportioned symmetrical tree. The silvery A. Engelmanni glauca is represented by a tree 9 feet high in prime health and condition; A. amabilis is, however, apparently too tender. Araucarias are occasionally injured, and Wellingtonias have suffered, but there are a few good examples. Cryptomeria elegans and Golden Yews do well, and contribute greatly to the beauty of the garden. From an elevated position above the river, termed the Duchess's Seat, in this part of the garden, a delightful view is obtained of the Alne winding past the Castle and through the grounds, the well-wooded and extensive park rising beyond, with the Castle on the left and the Brizlee Tower in the distance, constituting a pretty picture. A walk past the Castle and its velvety grass slopes conducts to the Dairy Grounds, a picturesque valley that has been well planted, and owing to the protection afforded by a high bank of deciduous trees, some of the Conifers there have reached a considerable size, Abies Douglasi in particular being represented by numbers of tall, handsome trees. Still beyond are the Hulne Parks west of the Tower, containing a variety of pleasant scenery, with several interesting ruins. This portion of the estate is surrounded by a wall thirteen miles long, and is said to include eighty miles of rides and walks. The Brizlee Tower, which was erected about 100 years since, as a kind of ornamental observatory, is 90 feet high, and commands a magnificent prospect, extending in clear weather from the Cheviots on the northern side to the Durham hills on the south, and embracing an astonishing variety of scenery.

These notes must, however, be concluded, though reluctantly, for the day. I spent at Alnwick was one of the most pleasant during my northern tour.—LEWIS CASTLE.

#### SELECTIONS OF APPLES AND PEARS.

SOME extracts were given last week from the admirable report of the Edinburgh Apple and Pear Congress, and the following selections of varieties are of such general interest that they are specially worthy of reproduction:—

##### APPLES AND PEARS SUITED FOR SCOTLAND.

Number of selectors, 77.

The best varieties for a regular supply during the season, with the number of votes each received, and the month for which the variety is suited.

*I. Dessert Apples.*—Irish Peach (43), August; Oslin (15), September; Thorle Pippin (24), October; Kerry Pippin (44), November; King of the Pippins (63), December; Cox's Orange Pippin (41), January; Ribston Pippin (48), February; Blenheim Pippin (53), March; Court of Wick (24), April; Duke of Devonshire (16), May.

*II.—Culinary Apples.*—Keswick Codlin (54), August; Lord Suffield (61), September; Ecklinville (66), October; Hawthornden (31), November; Stirling Castle (62), December; Tower of Glamis (25), January; Warner's King (55), February; Alfriston (51), March; Wellington (51), April; Northern Greening (21), May.

*III. Dessert Pears.*—Jargonelle (56), August; Williams' Bon Chretien (44), September; Beurré d'Amanlis (28), October; Louise Bonne of Jersey (32), November; Marie Louise (55), December; Winter Nelis (20), January; Hacon's Incomparable (22), February; Glou Morceau (27), March; Easter Beurré (40), April; Beurré Rance (24), May.

The most profitable varieties for the purposes stated, arranged alphabetically, with the number of votes each received.

*IV. Twelve Dessert Apples for Bushes, &c.*—Blenheim Pippin (25), Cambusnethan Pippin (24), Court of Wick (28), Cox's Orange Pippin (43), Golden Pippin (17), Irish Peach (48), Kerry Pippin (47), King of the Pippins (55), Oslin (22), Ribston Pippin (29), Thorle Pippin (31), Worcester Pearmain (33).

*V. Twelve Apples for Orchards.*—Alfriston (43), Blenheim Pippin (39), Ecklinville (56), Golden Noble (22), Hawthornden (24), Keswick Codlin (44), Lord Suffield (47), New Hawthornden (22), Stirling Castle (58), Tower of Glamis (32), Warner's King (53), Wellington (46).

*VI. Twelve Dessert Pears for Bushes, &c.*—Beurré d'Amanlis (28), Beurré d'Arenberg (17), Beurré de Capiaumont (10), Beurré Diel (19), Easter Beurré (16), Hacon's Incomparable (22), Jargonelle (27), Louise Bonne of Jersey (36), Marie Louise (21), Muirfowl's Egg (22), Swan's Egg (12), Williams' Bon Chretien (35).

*VII. Six Pears for Orchards.*—Autumn Bergamot (12), Crawford (17), Hesse (43), Louise Bonne of Jersey (13), Muirfowl's Egg (27), Swan's Egg (13).

*VIII. Three Stewing Pears.*—Catillac (45), Uvedale's St. Germain (19), Verulam (16).

##### APPLES AND PEARS SUITED FOR ENGLAND AND WALES.

Number of selectors, 32.

*I. Dessert Apples.*—Irish Peach (18), August; Worcester Pearmain (10), September; Kerry Pippin (15), October; King of the Pippins (19), Novem-



ber; Cox's Orange Pippin (26), December; Ribston Pippin (26), January; Blenheim Pippin (19), February; Court of Wick (10), March; Duke of Devonshire (15), April; Sturmer Pippin (10), May.

II. *Culinary Apples*.—Keswick Codlin (21), August; Lord Suffield (25), September; Ecklinville (14), October; Stirling Castle (15), November; Golden Noble (12), December; Warner's King (13), January; Blenheim Pippin (17), February; Alfriston (21), March; Wellington (25), April; Northern Greening (12), May.

III. *Dessert Pears*.—Jargonelle (22), August; Williams' Bon Chrétien (18), September; Beurré d'Amanlis (11), October; Louise Bonne of Jersey (20), November; Marie Louise (21), December; Winter Nelis (12), January; Glou Morceau (17), February; Easter Beurré (20), March; Josephine de Malines (16), April; Bergamotte d'Esperen (11), May.

IV. *Twelve Dessert Apples for Bushes, &c.*—Adams' Pearmain (11), Blenheim Pippin (18), Court of Wick (10), Court-pendu plat (13), Cox's Orange Pippin (24), Devonshire Quarrenden (11), Irish Peach (11), Kerry Pippin (20), King of the Pippins (25), Margil (10), Ribston Pippin (14), Worcester Pearmain (13).

V. *Twelve Apples for Orchards*.—Alfriston (16), Blenheim Pippin (17), Ecklinville (19), Golden Noble (9), Hawthornden (9), Keswick Codlin (25), King of the Pippins (11), Lord Suffield (22), Stirling Castle (13), Tower of Glamis (8), Warner's King (22), Wellington (30).

VI. *Twelve Dessert Pears for Bushes, &c.*—Beurré d'Amanlis (18), Beurré Bosc (11), Beurré Diel (14), Beurré Hardy (6), Beurré Superfin (10), Doyenné du Comice (7), Easter Beurré (6), Jargonelle (10), Louise Bonne of Jersey (23), Marie Louise (12), Pitmaston Duchess (8), Williams' Bon Chrétien (23).

VII. *Six Pears for Orchards*.—Beurré d'Amanlis (7), Beurré de Capiaumont (7), Hessele (17), Louise Bonne of Jersey (17), Swan's Egg (8), Williams' Bon Chrétien (21).

VIII. *Three Stewing Pears*.—Catillac (29), Uvedale's St. Germain (15), Verulam (16).

#### APPLES AND PEARS SUITED FOR IRELAND.

Number of selectors, 9.

I. *Dessert Apples*.—Irish Peach (6), August; Devonshire Quarrenden (4), September; Kerry Pippin (8), October; King of the Pippins (9), November; Cox's Orange Pippin (8), December; Ribston Pippin (6), January; Blenheim Pippin (8), February; Court of Wick (4), March; Court-pendu plat (4), April; Duke of Devonshire (4), May.

II. *Culinary Apples*.—Keswick Codlin (7), August; Lord Suffield (4), September; Ecklinville (7), October; Hawthornden (6), November; Tower of Glamis (4), December; Warner's King (4), January; Yorkshire Greening (5), February; Golden Noble (4), March; Alfriston (9), April; Wellington (8), May.

III. *Dessert Pears*.—Jargonelle (8), August; Williams' Bon Chrétien (7), September; Beurré d'Amanlis (5), October; Louise Bonne of Jersey (6), November; Marie Louise (8), December; Winter Nelis (5), January; Hacon's Incomparable (5), February; Glou Morceau (8), March; Easter Beurré (9), April; Bergamotte d'Esperen (6), May.

IV. *Twelve Dessert Apples for Bushes, &c.*—Blenheim Pippin (5), Court of Wick (5), Court-pendu plat (6), Cox's Orange Pippin (7), Devonshire Quarrenden (5), Golden Pippin (5), Irish Peach (4), Kerry Pippin (9), King of the Pippins (9), Ribston Pippin (3), Sam Young (4), Worcester Pearmain (4).

V. *Twelve Apples for Orchards*.—Alfriston (8), Blenheim Pippin (5), Ecklinville (6), Hawthornden (7), Keswick Codlin (6), King of the Pippins (4), Lord Suffield (5), Northern Greening (5), Stirling Castle (4), Warner's King (5), Wellington (7), Yorkshire Greening (4).

VI. *Twelve Dessert Pears for Bushes, &c.*—Beurré d'Amanlis (7), Beurré d'Aremberg (4), Beurré Diel (5), Beurré Superfin (5), Comte de Lamy (4), Doyenné du Comice (4), Easter Beurré (3), Hacon's Incomparable (6), Louise Bonne of Jersey (6), Marie Louise (5), Napoleon (4), Williams' Bon Chrétien (8).

VII. *Six Pears for Orchards*.—Aston Town (4), Beurré d'Amanlis (4), Hacon's Incomparable (4), Hessele (7), Louise Bonne of Jersey (7), Williams' Bon Chrétien (8).

VIII. *Three Stewing Pears*.—Catillac (9), Uvedale's St. Germain (6), Verulam (7).

#### LILIUM SPECIOSUM AND ITS VARIETIES.

AMONGST the reminiscences of a long horticultural life is one which, like most of the impressions of early days, is vivid enough—and that was the first time, not far short of fifty years ago, when I came home proud in the possession of a flowering plant of this very beautiful Lily. I will not say what I gave for it, for I fear it was a bit of extravagance, and people who can now buy them for a few pence can hardly think of guineas having been given for them, especially as imported bulbs do not, like those of *Lilium auratum*, quickly perish, but when we remember that not half that time has passed since 15 guineas was given for *L. auratum*, we need not wonder at the price given for *speciosum* in those earlier days. Having received last season from Messrs. Ant. Roozen & Sons some of the varieties mentioned by them in their catalogue, and also one or two from Mr. W. Bull, and having carefully noted them during their season of flowering in pots, perhaps the following notes may not be unacceptable to some of the many Lily lovers who read the Journal.

Before describing them, however, is it not a remarkable thing that so little result has been attained by the hybridiser with them? When we consider the prominence of the organs of fertilisation, and the facility with which they seed—a remark which equally applies to *L. auratum*—it is remarkable that so little has resulted from the many attempts which have been made at cross-breeding between the two. With the exception of *Lilium Park-*

mani I am not aware of any well defined hybrid, and this has suggested the question whether one or another of the two may not be a natural hybrid. Some have imagined that *auratum* is a hybrid between *speciosum* and *longifolium*; others that *speciosum* is the parent, and *auratum* a cross between it and *longifolium* or *eximium*. Be this as it may, it is somewhat strange that so little has been done; the varieties which have been produced are those of selection, noting amongst the seedlings those possessing any deviation from the type.

There are, I think, few well defined varieties in ordinary cultivation—album, punctatum, roseum, and rubrum—and those which I have to enumerate are derived from these. As is well known, they are, with the exception of punctatum, which seems to have a delicate constitution, hardy; they, at any rate, in the southern part of our islands, stand the severest winter and flower freely in the open, but anyone who wishes thoroughly to enjoy them must grow them in pots; not but what they are very beautiful in the garden, but they produce pollen so abundantly, that when rain comes it is splashed all over the delicate white ground of the flower and so injures its beauty. In the house they can be preserved from all this, and coming into flower as they do in August and September, when a good many of the ordinary denizens of the greenhouse have been put out of doors, they form a very agreeable addition to the flowers then available. There are many who would perhaps say they see very little difference in the varieties, but the same would be said by any outsider about the various collections of florist's flowers which, to the initiated, are full of variation.

Of the varieties of *L. s. album* there are three which I have grown—the old album, which has a considerable shade of green in it; then there is *Lilium Kratzeri*. This is a clearer, much clearer white; the habit is stout, height medium, and it is very free-flowering. But the finest of all in this section that I have seen is one I received from Mr. Ant. Roozen under the name of *Vestita*. It is stately in its growth, about 5 feet in height, while the flowers are of the purest white; the petals are broader than in the other two varieties, and the flowers altogether much finer. There is another kind which I have not grown—*corymbiferum*, in which the flowers are produced in clusters, being individually similar to album, but *Vestita* is without doubt the best of the white ones.

When we come to the other varieties it is somewhat difficult to say whether they are to be referred to roseum or rubrum—the lighter coloured ones must be referred to roseum. Of these I have had roseum improved, somewhat different from the type, and of better form, and monstrosum, where the flowers are produced in clusters varying but little from the ordinary form. It is, however, in the varieties of rubrum that we have the greatest varieties, and there are some very beautiful ones amongst them. Foremost I must place one, *L. s. superbum*, which I received from Mr. Bull. This is stately in growth, and produces freely flowers with very broad large petals, deeply suffused with red and spotted with purple, altogether a very striking flower, and I think equal in colour to any that I have seen. I do not know whether it is the same as *atro-purpureum* of Ant. Roozen, for I have not yet flowered it. *Lilium s. Melpomene*, raised by the late Mr. Hovey, is a very brilliant coloured flower, but not so large as the one just described. *L. s. macranthum* is another of Mr. Ant. Roozen's flowers, approaching in character to *superbum*; flowers large, and colour very bright. *Corymbiferum* is another effective variety, differing very little from the ordinary form in colour, but flowering in clusters rather than in single blooms. *Schulzmatri* has a deep rosy crimson blotch in the centre of the petal densely spotted with purple. The plant is of moderate height, and altogether a pleasing variety.

The one variety that I have always found more delicate than the rest is *punctatum*, and probably the faintness of its colouring would make it less pleasing than the more highly coloured sorts, but it is exceedingly pretty, and well worthy of cultivation.

There is little to say in the matter of cultivation, for most people have their own way of growing them, some advocating large pots, and some small ones. Some say, plant deep, others plant shallow; some say use loam and peat, others only peat and leaf mould; and as they succeed under these different methods of culture, I can only conclude that, like a good many other things, they submit easily to various methods of cultivation. I think that most people, however, are agreed that it is best to repot them as soon as possible after the stems have discoloured. The plan of standing them out exposed to all the autumnal rains is a bad one, and oftentimes the seed of disease is sown at this time. They should, however, be placed somewhere to ripen, but not withholding water from them. They may be safely potted in October. I do not use very large pots, and as the space at my command is very limited I do not grow them in large pots, but singly in large 32's or small 24's. I do not think it is a good plan to disturb them unnecessarily. The surface roots sprung from the base of the stem may be, and should be, carefully twisted off. I use simply

peat and small pieces of charcoal, and in potting leave a portion of the bulb exposed, and then, when it begins to make growth and push out rootlets at the base of the stem, I fill up the pot with lumps of peat. The pots are kept in a cold house, and then, when they have made growth, are brought up into the greenhouse. Here for a couple of months they continue to produce their delightful and fragrant blooms, and common though they be, they are deserving of a good deal more care and attention than they generally receive.—D., Deal.

### KEEPING PLANTS CLEAN.

KEEPING plants clean and free from insects is one of the greatest troubles of the modern gardener. Under the best conditions it is a task involving continual watchfulness and unceasing attention. Ordinarily there is not much time for watchfulness, and attention is chiefly devoted to keeping plants from being fairly overwhelmed. The extravagant employment of plants and flowers has added so materially to the already large number grown, that gardeners have found it impossible to cope with their work. The result is, that the work least noticeable to the ordinary observer goes undone, and the mischief wrought by insects up to a certain stage being completely out of sight, neglect is often allowed here. But no species of neglect shows plainer in the end than this, or more completely renders profitless the whole previous labour spent on the subject attacked. An insecticide that is at once cheap and quickly efficient is a desideratum that many hard-worked gardeners want. Efficient insecticides are not uncommon, but there is none so inexpensive as to allow them to be employed lavishly enough to do their work quickly. The great want is a preparation that will allow a large collection of plants to be passed rapidly through hand, either by dipping or syringing, and at so little expense, that the process may be repeated at intervals short enough to render the operations effective. Pure water is the cheapest of all, but in bad cases it is of no use. I remember having charge of a collection of stove plants infested with mealy bugs and other insects. The aid of cold water was called in, and a spreading *Stephanotis* attacked energetically. Every afternoon the nozzle of a Warner's garden engine was brought to bear on the invaders, and every afternoon the enemy appeared to have been completely routed, but by the afternoon succeeding the old position had been regained, and in the end the pump had to be withdrawn discredited. In cases of red spider attacks the efficacy of a stream of cold water is, however, well known, though not always acted on.

Next in simplicity to cold water is hot water, applied either with or without the addition of softsoap. Water almost boiling, when applied by means of a syringe, is a safe insecticide to use on plants with foliage not easily injured. Camellias, Peaches, and *Stephanotis*, are examples of such plants. I have employed it without inflicting any injury on large *Crotons* and *Ixoras* which were very dirty, and it is well known that these plants can be kept in a perfectly clean condition by such simple means, repeated, of course, when necessary. Many plants, however, are extremely susceptible to injury from hot water—*Gardenias*, *Ferns*, *Dracenas*, and *Grape Vines*, are common examples. About 120° is considered a perfectly safe temperature for syringing, but in some instances even that will be found too hot, the condition of the plant operated on at the time of application having, without doubt, a very distinct effect as to the heat being either hurtful or harmless. A careful and painstaking man will kill insects quite as effectively with a solution of softsoap in water inclining to hot as a less careful operator will with a good insecticide.

The employment of petroleum as a killing agent marked a great advance in this branch of practical gardening. It had, of course, been in use for a number of years. Here and there a bold cultivator had tried petroleum, and sometimes killed the insects together with their hosts. But it is to America that we are indebted for the first public intimation of the only safe and effective method of employing petroleum. This was by mixing milk, potash, or soap with the petroleum, so that, while the nature of the mixture was unchanged so far as insect life was concerned, no harm resulted to the plant. A simple way of so preparing petroleum consists in dissolving half a pound of softsoap in a small quantity of boiling water, when dissolved the soap appearing as a thin paste. An ounce and a half or 2 ozs. of oil are then added and mixed, then hot water to the quantity of three or four gallons. The mixture is ready for use, and capable of destroying all or any insects infesting plants. The better method of preparing the petroleum is, however, more complicated, though not too much so for everyday use. In this method the softsoap is heated until dissolved to a semi-liquid condition. Petroleum and boiling water are then added and mixed, and more of each continued to be added until the softsoap is all utilised. The material, while being prepared, is kept quite hot, as this facilitates the operation. The addition, in

the course of preparation, of a little spirits of turpentine completely hides the scent of the petroleum, the manufactured article, when ready for use, having the appearance of cold cream. So entirely harmless to vegetation is petroleum when prepared in this way, that the mixture may be employed without dilution and employed as an ointment. I have so used it to kill what before had proved an indestructible scale infesting *Cattleya pseudo-bulbs*, and that without in any way hurting the plants. When wanted for washing, the preparation is dissolved in warm or hot water, and is then ready for use. Mixed with clay it forms a capital winter dressing for Vines, and is used at the consistency of paint and applied with a brush.

The quickest method of treating a collection of plants is to make a good size tubful of the solution. A 5-inch potful to twelve to sixteen gallons of water indicates roughly the quantities required. If the water is at 90° when ready, the hardier foliaged plants should be dipped first, giving each one a turn in the solution, and passing them without delay through a bath of clean water at a slightly lower temperature. When the temperature has declined to 80° Orchids and more tender plants can be dipped, always giving a second bath in clean water. We have here safety, cheapness, rapidity, and efficiency. The only insect which such a solution fails to kill is mealy bug, but the external covering of this insect renders any insecticide powerless. The syringe is the simplest means of applying it. The force of the particles of water at once destroys this envelope, and effects the destruction of the insect. A collection of stove plants may be kept fairly clean in foliage and free from insects by such occasional dippings, the larger plants being syringed with the mixture. The only difficulty will be with mealy bug, and that for the reason explained. At the same-time sponging the plants is not a thing to be set aside as entirely superfluous. If there is time for sponging, do so, and especially during the season of quietness that is approaching. In sponging, all that is needed for plants in fairly clean condition is to dip the sponge in the mixture, squeeze as much liquid out again as possible, then draw once or twice over each leaf, and when another dip is necessary first wash the sponge in clean water, then proceed as above. If plants are thoroughly well cleaned during winter it is wonderful how clean they remain through the summer months.

It may be well to caution inexperienced cultivators—young men fond of experiments, especially—that with all insecticides there is a certain amount of danger in the using. I have not given any stated quantity of insecticide to be employed, for the simple reason that it is impossible to do so. I have found the quality of the soap differ, while the less refined the petroleum the greater its killing power. But apart from that, the quality of the water itself has a disturbing effect on this or any other solution. If the water is hard a certain quantity of the soap will be used in softening it, and some of the mineral oil will be set free, and the mixture in consequence be rendered more or less dangerous. On this account all water of a hard nature should be well boiled before using. A pinch of common washing soda added in the process will help to render the water soft and do no harm to plants. Rain water is, of course, much the best, but even deep well water may be used if prepared as recommended. The solution mixes in cold water, but is best mixed and used hot, being much more powerful in a hot state. Thrips, aphides, and red spider are readily destroyed at a low temperature by dipping. Mealy bug should be treated with hot water as high at least as 100° to 120°, and the solution forcibly applied with a syringe. Passing plants through clean water immediately after dipping is, though not absolutely necessary, a very safe proceeding, and should always be followed. All kinds of plants I have tried are perfectly safe under this treatment.—B.

### A LONG DROUGHT AND ITS EFFECTS.

AS far as my experience goes we have never experienced a more trying season than that of 1887. First we had a long spell of wintry weather which lasted till the end of March, and following this we had a most uncongential spring. The rainfall from February was exceptionally light or very much below the average, so that when the long spell of dry weather set in the ground was already in a comparatively dry state, and the springs far from standing at their normal height. Drought and hot weather was felt everywhere, very few districts being favoured with any rainfall throughout the "hot season," so that I need not comment further on this, but will at once proceed to discuss its effects in this and other districts that I have visited. From what I can learn very few wish for a repetition of the summer of 1887, but by far the majority would prefer it to a wet and sunless year such as we too often experience in this variable climate. The question which naturally arises, or ought to do so, is "What would have been the result of an average English summer had such been experienced this year?" In May and June we were all anticipating a late season, and a very late maturation of crops generally would undoubtedly have resulted had we not been favoured with such a glorious summer.



After all that has been said, and the amount of grumbling indulged in, what have we to lament? No doubt Strawberries, Raspberries, Red and Black Currants, and in a lesser degree Apples, Pears, and stone fruit generally, suffered badly from the long drought and excessive heat, while Peas, Cauliflowers, and salading cut up badly; but how quickly all this has been almost forgotten. A few rainy days has started the garden crops and many flowers into unwonted active growth, and those who persevered with the planting for winter generally, getting it established before the rains came, in most cases have the ground well covered, and the prospect of a scarcity is at present dispelled. Here and there we notice fruit trees and bushes nearly killed, and I have been surprised to observe several forest trees quite dead, these being evidently killed by drought. These are trifling occurrences, and all losses will be more than compensated for from the fact that trees of all kinds will be better ripened than has been the case for very many years, and we may reasonably anticipate a wonderful show of bloom next spring. In addition many trees of choicer sorts of fruits, notably Apples, will have been reinvigorated in a marked degree. The summer of 1886 benefited many of our trees, and they have both fruited well and formed much better growth than usual.

As we might naturally expect, the advocates of deep culture under all and every circumstances have long since concluded those who do not quite agree with them are having a very poor time of it indeed. As far as I am concerned the old battle might be fought over again, but I fancy readers of the *Journal of Horticulture* would prefer the matter to be dropped for a time, so much having been written on the subject. This being so, I will touch upon it as briefly as possible, and without any idea of reviving a well thrashed-out subject. I cannot help being amused at the "interviewing" tactics of "A Thinker," and candidly am surprised so good a man should seek to be corroborated by exhibitors of vegetables. He may bring forward the opinions of another hundred exhibitors without improving his position—in the eyes of practical gardeners at any rate—one iota. He forgets that I have "done a little to it," and know how to estimate such evidence at its proper worth. It must not be thought I wish to underrate the success attending the labours of the thirty successful exhibitors mentioned (page 112); far from it. It is very much to their credit that they have been so successful during such a trying season, but why did they mention only the trenching and mulching? What about the amount of watering, the supplies of liquid manure, the temporary shading in some cases, and the many hours of unpaid overtime expended over those vegetables?

Will my friend, "A Thinker," allow me to remind him of what once occurred to him when in charge of a garden somewhere not far from Lincolnshire? In the course of his interesting jottings he once mentioned he returned from a visit in time to find the garden men clearing off a breadth of Beet. It was being wheeled off to the pigs. My friend's respected employer gave the order, and in spite of remonstrances maintained that it was Mangold and not Beet that was growing where the latter ought to be. It was a forcible method of impressing a lesson on the gardener that coarse vegetables generally were not approved of in that establishment. Our thinking friend took the hint, and has since, more than once, "pointed the moral." Yet we are, now that it suits his purpose, to have the coarse prize vegetables held up for approbation. I may be blamed for calling prize vegetables coarse, but let me ask what good cooks care for huge Carrots, Onions, Parsnips, Turnips, Beet, Cauliflowers, Celery, Cabbage, and Potatoes, or those extra fine podded Beans and Peas? As a matter of fact, and as I have repeatedly pointed out, they will not have them if they can possibly help it; and who will dispute their wisdom? Surely not "A Thinker."

The most noteworthy failures in the way of summer vegetables were Peas and Cauliflowers. Even all those thirty exhibitors were not able to produce the latter, or I am very much mistaken. Trenching, mulching, and watering would not insure a healthy growth of either Peas or Cauliflowers, or we should have done better with them, for, strange as it may appear, we give the practice yet another trial. They cannot grow Peas and Cauliflowers in America during the summer months, and this summer we, too, were blessed with sunshine and heat too powerful for those crops. Did we but know what weather to expect there would be fewer failures, but unfortunately it is all a glorious uncertainty. Personally, while I am in charge of this garden I prefer hot and dry summers, and certainly should not resort to trenching under the impression that this laborious practice is the most economic and profitable in the long run. Some gardens, as I have from the first stated, are benefited by intelligent deep cultivation, and there are plenty very much injured by a reckless adoption of the plan. Heavy cold lands want sunshine and warmth, and they also require good surface culture. Our garden never worked so well before, the dry severe winter thoroughly pulverising it, and I am quite delighted with the progress various crops are yet making. Few private gardens are more closely cropped, and very few indeed get so little manure. With more of the latter and plenty of time to devote to the culture of vegetables for exhibition, we might upset the calculations of some of those "thirty spade-deep friends" of "A Thinker." The re-introduction of the phrase "surface tickling" may raise a smile on the faces of those who read it, but let me repeat there is a great difference in the surface culture Mr. Gilbert sometimes considers ample for his land, and the work of a straight spade in the hand of an able labourer.

I have more than once drawn attention to the extraordinary manner in which Lettuces, Kidney Beans, and Peas thrive on the ridges between the Celery trenches, and it is in these positions we have again secured,

the former especially, throughout the season. Lettuces last summer were very scarce, and we could only grow them on these ridges. No manure and little else but hard soil to root in, yet they grew to a good size and did not bolt much more quickly than usual. Our latest Peas were gathered from rows growing on unmanured and firm ground, and but for the birds these would continue to yield. Runner Beans sown on ordinarily dug ground in the coolest part of the garden, and watered twice only, have not yet ceased to be productive, and a remarkably heavy crop of Old Ashleaf Potatoes were lifted from a piece of undug unmanured ground. The latter were planted as late as the second week in May, being simply laid on the surface and moulded over. They formed scarcely any haulm, but when lifted we were surprised at the size of the tubers and the great weight of the crop. We wanted several bushels of "seed" Potatoes, and we obtained ten barrowloads of large and rather ugly tubers, but which are of excellent quality. What say our "spade-deep friends" to this curious phenomenon?—W. IGGULDEN.

### THE BIRMINGHAM GARDENERS' ASSOCIATION.

THE first meeting of the autumn session was held in the Midland Institute on Wednesday evening the 27th inst., when the Mayor of Birmingham, Sir Thomas Martineau, presided, and nearly 200 members attended. A very interesting practical paper on the Rose was read by the Rev. J. A. Williams, Alderminster, Stratford-on-Avon. Mr. Williams brought with him a number of very fine Tea Rose blooms, and obtained from Messrs. Perkins of Coventry samples of Roses on various stocks as well as Rose plants as examples of good and bad pruning. Mr. Williams divided his subject under the following heads:—Soil and Manure, Buying Plants, Planting, Pruning. As to soil and manure, remarked that it was a common fallacy that they could be grown well only in clay soil. Roses on their own roots do not like a clay soil, but the Dog Rose does. The late Mr. Rivers introduced the Manetti stock, which is generally used for Roses, but it perishes in cold, clayey soils. Discard the Manetti, Mr. Williams says, and plant Roses on the Briar. On light soils manure with cowdung, with deep trenching when practicable, and fully 4 inches of it, or fish refuse deep in the trench. This with chopped turf and road scrapings and lump charcoal and bones will produce fine blooms. Liquid manure to be used often and regularly, and in a clear state, and ordinary water in a clear state. Mulch with plenty of manure, but not in a raw state.

In buying, buy close at hand if plants can be had good and true, and if from a distance to be sent by parcels post or passenger train, securely packed so as to come quickly. In planting, dig a hole so large that when the plant is placed in it there is ample room for the roots to extend. Plant by the end of October or the beginning of November, if possible, and root-action will speedily commence. For Roses on the Manetti, the junction should be quite 3 inches below the soil; on the seedling Briar fully 1½ inch, even 3 inches, and in either case "tonguing" the scion, and trim old decaying roots only. Mr. Williams illustrated a portion of his lecture by examples of dwarf Roses, H.P.'s, and Teas on the seedling Briar, and H.P.'s on Briar cuttings, and in the latter case the roots were more numerous and fibrous, and a good specimen of a root-feeding plant; but early or late pruning depends upon the soil and situation. For beds Roses of a colour continuous blooming and an even habit of growth were recommended.

Tea Roses are to a great extent as hardy as H.P.'s, and will resist mildew and other pests, and are in bloom from April until December. Mr. Williams stated that from one plant of Marie Van Houtte he had that morning cut fifty blooms. In the Alderminster Rectory Gardens the plants are grown in an exposed situation, but close to water, and with an open autumn Mr. Williams cuts fully up to Christmas, and recommends Tea Roses on the seedling Briar or Briar roots.

In pruning H.P.'s he explained how and when to prune, advocating severe pruning the first year, and not so severe after, and with examples of well and badly pruned Rose trees was able to convey to his hearers practical evidence of the result. The properly pruned plant was all a young Rose tree should be. In the other the growth had been left 12 inches long and produced thin unproductive wood.

Then, with respect to budding and propagating. Bud from a good strain—that is, from shoots producing fine quality flowers, using every eye from such shoots, and in November shorten back the long shoots of Roses, giving a final pruning in March.

We are only able here to give a brief outline of an excellent evening's advice as to growing the Rose. Very cordial votes of thanks were voted to Mr. Williams for his lecture and to the Mayor for presiding. The Gardeners' Association has just published in book form the papers read during the last sessions.

### FACTS ABOUT FRUIT.

UNDER this heading, on p. 279, are some statements from Mr. Samuel Morgan, which are scarcely to be relied upon by those who wish to arrive at "facts" about fruit. They bear on their face the marks of the enthusiast rather than those of the shrewd practical worker. Is it true that we can produce in this country "in profusion," such nutritious and medicinal (why "medicinal?") fruits as Apples, Pears, Tomatoes, Plums, and Nuts? I think not; but no doubt Mr. Sampson Morgan, being a dealer, is in a better position to judge. What does he mean by saying (in the same paragraph, too), that in one year we imported Apples to the value of £717,031, and yet a few lines further on that from "the States we import Apples to the value of £500,000, from



Belgium and other continental countries to the value of £1,000,000, and from Canada to the value of £91,000?"

That is a small matter, for enthusiasts are not careful as to figures; but what does Mr. Morgan mean by the statement that all the ills of the flesh can be cured or mitigated by the use of fruit? The sick man does not care for what is called the Grape cure, the Tomato cure, the " &c." cure. What he wants is prevention. There is sound common sense in the statement that it is best for each to decide for himself how fruit should be eaten, but it is news to learn that the skin of the Plum may be eaten with safety. To the healthy organism there is probably little risk in eating that, but it sounds strange when in the same tones we are told not to eat the skin of the Peach or of the Apple, and that all skins are insoluble. "Fruit has its best effect when eaten with brown wholemeal bread, not as dessert, but food." Why "brown?" Is there any other coloured wholemeal bread—is there, in fact, any wholemeal bread which is well baked and not brown? "Roasted Apples are slightly laxative," we are told; but when the system becomes accustomed to them, what is the effect then? Pears are, it seems, more digestible than Apples, but Gooseberries should be cooked if eaten in any quantity. How does our kindly instructor know all these "facts?" Has he a monopoly of knowledge on such matters, or is he airing stale platitudes? Plums, we are told, "do not digest as well as Grapes," and the "same" it appears is true of Cherries, though what the "same" is Mr. Sampson Morgan leaves to conjecture, though he does say one should reject the stones of Grapes and Cherries, and discard the skins of Grapes. Why? Surely no one swallows the stones of Cherries, but most people eat them "skin and all."

As to Mr. Morgan's remarks about preserving fruit, I wish he had been more explicit. If he knows of any method of doing that without using sugar or some other preservative, why does he not describe it? for he may rest assured that the British people will eat as much fruit as can be provided for them at a low price, and still even "spring a point or two," if sound fruit can be presented to them, without inquiring too closely into its actual food value. "Sound, ripe fruit," is, he tells us, "very beneficial." Just so, that is not news. What we want is to get fruit at a low price, and that is the point at which Mr. Sampson Morgan leaves us. Possibly he is going to start as a "grower" himself, and when he does so it is certain that he will modify some of his opinions, especially if he tries the American system of drying or evaporating "fruit for winter." However, his remarks may set people thinking, and that, after all, is the principal thing to aim at.—COMMON SENSE.



#### KITCHEN GARDEN.

**FORCING PITS.**—The forcing season is fast approaching, and attention should now be given to making preparation for it. Where pits with flues are devoted to it clean the flues out thoroughly from end to end, and when the covers are removed to do this see that they are replaced without leaving any small holes about the edges, and whether the covers are moved or not repair all defects. In forcing roots they are frequently placed on a bed over the flue, and when once in they cannot be well removed until forcing is done, but if there is a flaw underneath it cannot be well repaired during forcing, and it may do much harm before this is over. We have known Asparagus roots placed on a flue which did well until cutting began, when there was a leakage of smoke and the crop was nearly lost. The same remarks apply to hot-water pipes, but they are not so liable to get out of order as the flues. A dirty flue never beats well, and they should all be cleaned out before the winter sets in. Limewashing pits at this season is also a good plan, and all frames should be washed and painted, and the glass lights made quite clean. Fallen tree leaves always play an important part in hotbed making, and they should be collected for the early beds. The Beech and the Oak leaves are not falling very much yet, but the Sycamores and some others are, and although these are not very lasting in a bed they do very well for a beginning. Handlights are also very useful, and if these require repairing have them done before the day they are wanted. All such work should be done at once.

**EARTHING CELERY.**—There are various times and ways of doing this. In some cases it is left until nearly fully grown, then one good earthing is given, and in others it is earthed little by little throughout the autumn months. Both ways may be practised, but the one earthing plan is not useful where the Celery is wanted immediately, as stems that have never been earthed will be very hard and tough, and must have the soil about them for several weeks before they become blanched and tender. Of large and small Celery we prefer the latter as being the most compact and useful, as there are too many superfluous leaves on the large sticks; in fact, half of them are generally thrown away, and only the centre used. Large plants are also liable to grow very tall, and then the leaves and stems are sure to break and fall over. This is objectionable, and may be avoided by tying a piece of matting round

each plant some distance above the soil, and not too tight, and in all cases of earthing the greatest care should be taken that none of the soil falls into the centre of the plants. Earthing should only be done when the soil is dry, and break it fine with the spade along the sides of the rows, and push it up to the plants with the hands. We always tie our plants to keep them close together before earthing, and untie them again when the operation is completed.

**THINNING YOUNG VEGETABLES.**—All vegetables are better in winter when well thinned before the days shorten too much. This applies particularly at the present time to Spinach, Radishes, Turnips, Lettuces, and Endive. When these are kept too close in the rows they draw each other up, and then when the frost comes they are killed. It is different, however, when they are well thinned in good time or before they become crowded, as then they grow dwarf and robust, and are in every way capable of bearing much severe weather without being injured to an unprofitable extent.

**WEEDS IN AUTUMN-SOWN ONIONS.**—The autumn-sown Onions are now growing freely, and so are the weeds amongst them. These very soon become a mat in the rows, and they act as injuriously on the young plants as overcrowding. Some might think that they would protect the plants, and no doubt they would if they were only appearing in the time of frost; but it is before that comes that they do the mischief. All who wish to have sturdy Onion plants throughout the winter and by next spring should keep them quite free from weeds at the present time.

**MORE CABBAGES.**—The present is a good time to make a second plantation of Cabbages. Those planted before this time might, if the winter is mild, all bolt to flower prematurely, while the present plantation would all heart, and in any case it is a good plan to have more than one lot to depend on. Vacant ground is now plentiful; plants, too, are grown up ready for planting, and it only requires attention to have another fine quarter of young plants. At present we are filling a large piece with Ellam's Early, and we are planting them at a distance of 16 inches apart each way. It is an excellent little early Cabbage.

**TURNIPS.**—Where many were sown to come in at this time they may be too numerous, and some of them may give indication of decaying before they are required. To prevent this pull them up and store them in a cool not too dry shed. A little leaf soil may be thrown over them to prevent them from shrivelling.

**HERBS.**—These are growing a second time, we have as much fresh new Mint now as we had in May, and other varieties are equally productive, which offers those who neglected to dry them some time ago a chance of doing so now. Herbs of all kinds are very useful during the winter, in fact they are indispensable, and many of them will be required before they grow in spring, which makes it all the more necessary that they should be stored in quantity. We like the plan of drying them thoroughly and rubbing them down small so as to put them in bottles and cork them.

**LETTUCE AND ENDIVE IN FRAMES.**—These may be grown in frames during the greater part of the winter. In some cases these are allowed to grow large and remain in the open until November, then they are lifted and stored in the frames. When treated in this way they seldom root anew, and they do not grow much more. Indeed they very often decline or decay, especially if the weather is damp; but if the young plants are lifted when small, as many of them are now, and planted in frames in good soil, they soon begin to grow and make capital plants before the winter. These are not half so liable to decay as newly planted ones in November or December, and planting them small and allowing them to grow is much the best way to secure a fine stock of winter Lettuces and Endive.

#### FRUIT FORCING.

**MELONS.**—Be careful in the application of water, but the latest plants with fruit swelling must not be allowed to become dry at the roots. Keep up moderate moisture by damping every morning and at closing time, earthing the plants as required. Remove all superfluous growths as they appear, and maintain a temperature of 65° to 70° at night, 70° to 75° by day, up to 85° or 90° with sun. Keep the bottom heat at about 80°. Fruit ripening will be the better of a little extra fire heat and a little air constantly; a dry state at the roots, but not so dry as to cause the leaves to flag, accelerates the ripening process. In dung-heated pits and frames no water will be required after this. Keep the frames well lined, admitting a little air constantly, which with the fruit raised well above the surface of the bed will do much to impart flavour. Any fruit it is wished to keep for a time should be cut when changing with a good portion of stem, and be kept in a dry airy room, or if wanted ripe at once they may be placed in a warm airy house in the full sun, and they ripen better than in frames or pits devoid of artificial warmth.

**VINES.**—*Early-forced Houses.*—Vines that are to be forced to furnish ripe Grapes in March or early April should be started by the middle of November. It is not advisable to start permanently planted Vines so early where there is convenience for growing some in pots, as it is a great strain on the energies of the plants through their having to make their growth at the dullest period of the year and to rest at the hottest. Retain some lateral growth as an outlet for any sap which the roots absorb, and which without the laterals would probably force the buds that are intended to furnish the succeeding season's crop of Grapes. The house after pruning should be kept cool and dry, and the outside border protected from autumn rains by covering them before the ground is chilled with continued wet and cold. A good covering of dry leaves, with a little litter to prevent the leaves blowing about, is an effective

protection, and if tarpaulin is employed over all to throw off heavy rains and snow nothing further need be done to outside borders, and they need not be covered until they have been well moistened by the autumn rains, yet before they become soddened and much reduced in temperature. Where, however, fermenting materials are available they are a great aid in forcing operations, and especially so for placing inside the house to generate and maintain a genial condition of the atmosphere, without recourse to so much fire heat or sprinklings from the syringe. The materials need not be used until the house is closed, but they will need to be thrown into a heap a week or ten days previously, turned and moistened if necessary. Three parts of Oak or Beech leaves to one of stable litter will give a more suitable warmth and ammonia vapour than all dung. Mix well together when thrown into the heap, damping if dry, turning when getting warm, again damping if necessary, and when well warmed through they are fit for placing in the house.

**Early forced Vines in Pots.**—If bottom heat can be given to start them they will mark their appreciation by breaking well. Provided there is a bed of about 3 feet depth and 4 feet width, the pots may be raised upon those bricks in pillar fashion, so that their rims are slightly higher than the pit edge, and so that the pots will be in the centre of the bed. Leaves being placed in to fill the pit a gentle warmth will be afforded the Vines, and the roots will pass from the pots into the leaves, deriving support beneficial to the growth of the Vines. The temperature at the roots ought not to exceed 75°, and in the atmosphere 50° to 55° by artificial means, until the buds swell, then gradually increase it to 60° to 65° when they are breaking. The canes should be depressed to a horizontal position to secure their breaking regularly. Damp the house and canes morning and afternoon. To have ripe Grapes in March the Vines should not be started later than the early part of November.

**Late Grapes.**—These will be thoroughly ripe if they were hastened in spring by the aid of fire heat, which is much preferable to having to maintain a foreign temperature after October comes in to secure the ripening of the fruit. In the latter case the temperature must not be less than 70° to 75° by day and 65° at night, falling 5° through the night, allowing an advance to 80° or 85° from sun heat, continuing this until the Grapes are ripe, at least until the wood is brown and hard. The fruit being thoroughly ripe, in which state only can the Grapes be expected to winter satisfactorily, and the wood thoroughly matured, all spray or laterals may be removed down to the main buds, ventilating freely on all favourable occasions. Fire heat will then only be necessary to prevent the temperature falling below 50°. To prevent dust settling upon the berries raking or sweeping must not be practised. Mats or dry clean straw laid over the inside borders will to some extent prevent evaporation, assist in keeping the atmosphere dry, and prevent the soil cracking. The outside borders must be covered if the fruit is to keep satisfactorily. Glass lights are best, wooden shutters good, and tarpaulin over dry bracken or straw answers well. A good thick thatch of bracken or straw is very serviceable.

**Young Vines.**—Those that have a disposition to keep on growing to a late period may be checked by stopping the shoots moderately, and facilitate the ripening of the wood by a high and dry temperature by day, shutting off the heat and keeping the ventilators open by night.

**CHERRIES.**—If it is intended to plant any trees it should be seen to as soon as the leaves have fallen, or if the trees are at hand those trained to walls for four to six years are best, and repeatedly lifted, they may be planted as soon as the leaves give indications of falling. The Cherry—like all stone fruits—thrives best in a calcareous soil, turfy loam inclined to be strong rather than light, with a tenth of old mortar rubbish and a sixth of road serapings thoroughly incorporated, answering well, the border being about 24 inches deep, over 9 inches to a foot of drainage, secured with a layer of old mortar rubbish, and about 6 feet wide, which is ample for trees grown under glass. Black Tartarian and May Duke are the best varieties, but Early Rivers is a welcome addition, and especially valuable for early dishes. The yellow-fleshed varieties form an excellent addition to the dessert when fresh fruit is not plentiful; Early Jaboulay, Elton, and Governor Wood are first-rate. The lights having been removed they need not be replaced for a month or six weeks, the old surface soil being removed without injury to the roots and replaced with fresh compost, that above named answering with the addition of a fourth of manure. Trees in pots required to be shifted into a larger size should be attended to at once; and those not required to be so treated should be turned out of the pots, removing a few inches of soil from the base, cutting back the roots, and supply fresh loam, adding about a tenth of old mortar rubbish and a sprinkling of half-inch bones, good drainage being provided. The surface soil should be removed, supplying the above compost, adding a fourth of decayed manure. The soil, whether for trees planted out or in pots, should be made firm. Afford a good watering, and place the trees where they can have plenty of air. If stood outdoors they should be plunged over the rim of the pots.

#### PLANT HOUSES.

**Camellias.**—Those that require cleaning should be attended to without delay. This is especially necessary where the buds are swelling rapidly. Those of later growth can be cleaned afterwards if the time cannot now be devoted to them. Be careful not to use insecticides too strong at this period of the development of the flower buds, for they are easily checked, which would most probably result in them falling in a short time or before the buds are fully developed. If the plants are

syringed with a solution of petroleum and water it is much better to do so twice than to subject them to one strong application. No better insecticide than petroleum can be used, for if followed by syringing the plants at intervals of a few weeks it is certain to effect the destruction of scale, which is the worst enemy of the Camellia. At this period of the plant's growth it will be safe to use 3 ozs. of petroleum to four gallons of water. This must be well mixed before it is distributed over the plant, and repeated again in about a fortnight. If the leaves are covered with a black glutinous matter, which is deposited principally by scale, add a lump of common washing soda to each four gallons about the size of a Cob Nut. This will loosen all the dirt, which can then be washed off by subjecting the plants to a heavy syringing. Plants that have been outside must be carefully treated after they are housed. If they are stood upon a dry base and the atmosphere about them becomes dry they are certain to receive a check, and the buds will eventually fall. Keep the atmosphere moderately moist and syringe the plants twice daily. They must also be watered with great care at their roots, for it is of the utmost importance that they are neither too wet nor too dry. Those that are confined at the roots in tubs or pots may be supplied with weak stimulants every time they need water. Stimulants in a strong state must be avoided, because greater harm than good will result; but, if applied as directed, the plants will be greatly benefited, for in their present stage they need support more than at any other period of their growth.

**Azaleas.**—Where these plants are placed outside for a short time annually, no time should be lost in getting them under cover; in fact, they may be placed at once in their winter quarters. Before doing so, however, examine them, and if any trace of thrips exists upon the plants thoroughly syringe them with a solution of tobacco water and soft soap, in which has been dissolved a small piece of washing soda about the size of a Cob Nut to each 4 gallons of the mixture; about 1½ oz. of soap will do in the same quantity. The tobacco water should be diluted until it is about the colour of stout. If this washing is thoroughly done, and the house in which they are placed is clean, the plants will give very little more trouble in this respect until they have flowered. Give the plants full exposure to the sun with plenty of air day and night. Keep the atmosphere rather moist, syringing the plants once or twice daily according to the weather. Supply water carefully to the roots, and do not allow the plants in any stage to suffer by an insufficient supply of water.

**Greenhouse Rhododendrons.**—These should also be under cover, for nothing does them more harm than being saturated by heavy rains. If any thrips are found on the plants syringe them the same as advised for Azaleas. These insects are easily found on Rhododendrons, for they only attack the upper side of the foliage. These plants should stand on some moisture-holding material.

**Amaryllises.**—These will be showing signs of going to rest. They should be fully exposed to the sun and the atmosphere kept moderately dry. Less water should also be given at their roots, but it must not be withheld suddenly. The supply must be gradually diminished, for by this means only can their fleshy roots be preserved in good condition. If the supply of water is withheld suddenly they are certain to perish.

#### THE FLOWER GARDEN AND PLEASURE GROUND.

**Shrubby Calceolarias and Violas.**—We give these almost identical treatment from first to last. Both being comparatively hardy, the Calceolaria the least so, the roughest of frames are all that are necessary for protecting them during winter, these being occasionally covered with mats or straw litter. It is not advisable to insert the cuttings or to cause them to root early, as the less growth they make before or during the winter the better. Early in October is quite soon enough to put in the cuttings, and no bottom heat whatever is necessary or advisable. Ordinary garden frames being devoted to them, a thick layer of half decayed stable manure and leaves should be firmly packed in the bottom, on this about 4 inches of loamy soil, finishing off with about 2 inches of sifted sandy soil, and this may farther be faced with sharp sand. In the case of the Calceolarias the preference should be given to the firm flowerless shoots, these, cut to a joint and the lower pair of leaves trimmed off, being about 3 inches long. They should at once be dibbled in about 4 inches apart each way, watered, and kept close and shaded from bright sunshine till rooted. Subsequently they should receive plenty of air on all favourable occasions, so as to keep them alive and sturdy till the time has arrived for encouraging quick growth. The short flowerless shoots of Violas springing from the stems of the old plants are most suitable for cuttings, but if these be scarce the tops of the old shoots may be taken off and rooted, these also usually pushing up healthy growth during the following spring.

**Carnations and Pinks.**—Layered shoots of the former ought now to be well rooted and ready for separation from the parent plants. In the southern districts the bulk of the plants may safely be placed out at once where they are to flower next season, but on the whole we prefer to pot them up and winter them in cold frames or pits. We use clean well-drained 3½-inch pots, and a compost consisting of two parts of good loam to one of leaf soil, adding plenty of sharp sand. The young plants require to be carefully and firmly potted, and after being set in a frame should be watered and kept rather close for a few days. Being well rooted they require no shading, as this encourages a weakly growth. They ought during the winter to receive all the light and air possible, being closely protected from severe frosts only. Ours are raised near

to the glass in a sunny pit, and are usually sturdy well rooted plants when either planted out or given a shift in the spring.

The commoner sorts, notably the good old Clove Carnation, may be readily increased by division at the present time. Even quite long rootless pieces will strike in the open ground, our best plants in the herbaceous borders being established in that way. No trimming is necessary, the principal point to be observed being to insert them deep enough. They should be buried up to the lower healthy leaves, and they usually fail to strike if any bare portions of the stems are exposed. The popular Mrs. Sinkins and other Pinks may be increased in a similar manner. They are often greatly improved by being split into small tufts, a few roots, if possible, being preserved with each. Both Carnations and Pinks seem to thrive best on raised beds, and all delight in a deeply worked loamy soil to which has been added a liberal dressing of old Mushroom bed manure and road grit.

*Pyrethrums.*—Herbaceous Pyrethrums are a beautiful and serviceable class of plants, and perfectly hardy. Unfortunately slugs are particularly fond of them, and frequently destroy all young growth as it appears. This soon kills the plants. It is advisable, and in many cases quite necessary, to lift the choicer varieties, splitting these carefully with a plunging fork, and potting up the divisions thus formed. Any good loamy soil suits them, and after being placed in pots large enough to hold them comfortably, they may set in a cold frame or pit for the winter. Strong clumps of commoner sorts may also be increased and much benefited by division and replanting in good fresh soil.

*Chrysanthemums.*—These promise to be remarkably floriferous, the early sorts being already in full bloom. When left in the open they are liable to be much damaged by winds, rain, and frosts. If properly staked up before the growths have fallen about winds do not greatly disfigure the plants, and they will also stand a moderate amount of wet weather or dry frosts. To be certain of a lot of bloom, however, some sort of protection must be afforded. If grouped together a temporary framework may easily be erected over them, this supporting the blinds or mats that are to ward off the frosts. If this cannot be managed it is advisable to lift some of the best of the plants and replant against a wall or the blank wall of a plant or fruit house, where they may readily be protected with mats or other material. They can usually be moved with a good ball of soil and roots, and many either pot up plants from the open ground, or else transplant to borders in fruit houses or the conservatory. Lifted plants ought not at first to be exposed to a bright sunshine; they should never suffer for want of water.

*Disbudding Chrysanthemums.*—Those few who go to the length of disbudding their outdoor Chrysanthemums are frequently well rewarded for their pains. It is those planted against walls and thoroughly strong and well established that pay best for this treatment. The Rundle family rarely assume a perfect globe form unless disbudded, and their beauty is not therefore fully realised. Many other incurved and Japanese sorts are also improved by disbudding, one good bloom being worth more than a cluster of imperfect flowers. The strong central bud only in each terminal cluster should be reserved, the remainder being either removed with the point of a pencil or stick, or with the aid of Grape scissors. It ought to be done at once. Outside Chrysanthemums in many positions have not recently had sufficient moisture at the roots. A good soaking of either clear water or liquid manure will not be thrown away on them.

## THE BEE-KEEPER.

### NOTES ON BEES.

#### BEES IN A BOX.

"INQUIRER" wishes to know how best to preserve a swarm of bees in a box 16 inches by 13 by 10. Keep the bees until they have from 20 to 25 lbs. of honey. Preserve them from external damp, and cover the box about 4 inches deep with dried grass on the top, and 2 inches or so at the sides, and it will be all the better if a ventilating floor be provided. That is easily done by making a box the same size as the hive, covering it with perforated zinc, a foot in each corner, and a close-fitting trap door beneath. If a swarm is wanted add a super when the honey flow commences next summer. If no swarm is wanted, then add proper sized boxes filled with foundation when the bees begin to show signs of crowding the hive next spring, and add supers when required.

#### THE WEATHER AND HONEY.

That 1887 has been a good honey season generally none who has managed bees properly can deny; yet on my way south a few days ago I learned from a station master and bee-keeper, to my astonishment, that one of

the finest districts for honey in Scotland had given no returns this year. The cause was said to be the cold and backward May of which we had all felt the influence, but what was most surprising to me was I had in my possession a letter from a bee-keeper situated in the midst of this district as follows:—"My bees have given a great quantity of honey, particularly the Carniolians you assisted me to introduce last year." The writer of that letter was a pupil of mine, while the unfortunate bee-keepers who have no honey are those who, advised by the British Bee-keepers' Association, spread brood and contract during winter. Doubtless, although it has been a productive season we have experienced much better, and although hives that were in good order have reached a great weight, those that were not have done little.

#### THE HEATHER SEASON.

This has been much the same as the Clover one. During the time the Heather was in bloom the weather was unsettled; only twice did the bees get the advantage of two fine days in succession. The weather, however, was warm, and that compensated for other adverse circumstances. Some hives have made extraordinary weights. The large swarm of bees that I described as having made upwards of 100 lbs. in fourteen days, in two months' time and with not more than twenty honey-gathering days, weighs now, together with the 60 lbs. taken from it before it was sent to the Heather, 244 lbs., the tare for boxes being 30 lbs., and it is, like all others, lighter than it was. This weight is by no means an exceptional one, as there are heavier ones. Twelve hives from a truck load weigh a ton. The heaviest are the Syrians, Carniolians, and crossed Cyprians, and yet the two lightest are a pure Syrian and pure Carniolian. These two lots of bees are kept in small hives for breeding purposes, are therefore similarly situated to those bees whose masters complain of the unproductiveness of the foreign ones. Give the Syrian and Carniolian races of bees plenty of scope in their hives and they will do well, as they have done with me. Mr. Pettigrew used to give the results of the heaviest hives in the Carluke district. The following taken from the *Hamilton Advertiser* gives the weight of one near Carluke this year:—"The bee-keepers in Braidwood now have their hives back from the Heather. At the beginning of the season there is usually a little rivalry who will have the heaviest skep. This year, Mr. William Steel, Hamperhill Colliery, takes the lead with a splendid top of first-class quality, weighing 178 lbs, the largest ever known in the district."

#### PREPARATIONS FOR WINTER.

No time should be lost in having all hives that admit wet put right, and everything done to keep bees comfortable. These chilly nights are telling on the bees in the observatory hive, many creeping out of the hive in a weakly state from the effects of the cold. I have put it into winter quarters as well as my other stocks. No work that is necessary to bees and hives should be performed after the middle of October. A zinc-covered roof that had a ridge soldered on the top and overlapped the other part 2 inches was defectively soldered for quarter of an inch only, and at this little defect the rain was drawn up by capillary attraction, carried right along the ridge, and dripped on the top of the hive at the opposite end from where it entered. The same thing occurs in many ways, so great care should be taken to keep the insidious enemy out.

#### SUSPENDING SECTIONS FROM THE TOP BAR.

Every day brings further proof that sections as they are made and managed upon the hive are unsatisfactory.



The expense of having many crates and dividing into so many compartments, together with the broad bottom rail, all tend to obstruct the bees and lessen the honey harvest. The following plan is perhaps the cheapest, most simple and effective plan. The crates are simply one of the divisions of the cheap hive, fitted with top bars  $1\frac{3}{4}$  broad, L shaped staples are driven at the proper distances on one edge of top bar, so that the section is held equally from both ends. To hold the section firmly put it close to the underside top bar and slide beneath the short end of the staple, now drive one in the centre on the opposite edge, and they will bear 50 lbs. if necessary. The sections may either have no bottom rail or a very narrow one, and they may be of one or many sizes as fancy dictates. The ease by which such sections are manipulated and the advantages to both bees and bee-master cannot be over-estimated.—A LANARKSHIRE BEE-KEEPER.

#### TEMPER OF BEES—PLEA FOR CYPRIANS.

THE temper of the various races of bees is, perhaps, the principal subject of inquiry by the masses concerning them. With many this makes little difference. In a large apiary run for extracted honey, such as we find in the southern counties of California, the rapid handling that is generally necessary will render any bee vicious. Bee-keepers get used to it to such a degree that they are as much at home among irritable bees as among gentle ones.

Others, however, desire to find bees that will permit frequent examination without resenting it. Having but few colonies of bees, they can spare the time to handle slowly and gently, and to pet the insects without stint. Unless it be the Carniolians, which I have not seen, it is only a trite statement that Italians in their purity surpass all others for such persons. I have worked them repeatedly in a yard of ten or a dozen colonies, opening hives and handling all the combs without smoker or veil, and the bees have generally paid no more attention to me than would flies on a window. However, I must say that in such a yard I have had even hybrids so trained to slow handling that I could do likewise. Among the bees in a larger apiary I do not make it a point to venture without both a veil and a smoker.

I have for the past season been handling Cyprians, both pure and hybridised. Imbued as I had been with impressions of their irritability almost beyond the control of the operator, the season's experience has been a constant surprise. While having my smoker ever ready, I have seldom had occasion to use it. Even in taking off the cover from a hive, I seldom have to blow in any puffs of smoke to control them. In taking out combs I have found that the bees remain evenly spread upon them, and they fly but little. I have received but very few stings from Cyprians, except when I have accidentally pinched them. The queens are easily found, although they are now more nervous than Italian queens, as well as smaller, and inclined to be striped. While easily found, they seek the edges of the comb more noticeably than do the Italians.

The crosses between the Cyprians and the blacks are in no respect worse than the Italian hybrids. They vary much, however, in disposition. I find some colonies that I can handle easily, and others that I must subdue with smoke. While in ordinary handling many of these hybrids as well as pure-bloods will remain quietly on the combs, yet a sudden jar is sufficient to dislodge nearly all of them. In handling both pure-bloods and hybrids thus, I have noted that the bees thus thrown into the air immediately start for the entrance, instead of seeking the vulnerable parts of my person, as I expected.

I will say that I have not extracted this year, and this must have made some difference. I have one colony from a Syrian queen mated with a Cyprian drone. Her bees are light yellow, and bear handling much the same as pure Cyprians.

I have handled pure Holy Land bees a little, and their crosses with blacks much more, during former seasons in Mr. R. Wilkins' apiaries in Ventura county. There, in the height of the extracting season, they bore a good comparison with the Italian hybrid bees that were in the same circumstances.

Thus it will be seen that while some find the new races intractable, others find them easily managed. I only add my experience as one in a general column of figures, and I claim for it only its own influence on the general footing up. The Cyprians seem to be very active and excellent honey gatherers. I do not believe that they can be surpassed.—A. NORTON (in *American Bee Journal*).

#### TRADE CATALOGUES RECEIVED.

William Fell & Co, Hexham.—*Autumn Catalogue of Dutch Flower Roots*, 1887.

C. Turner, Slough.—*Catalogue of Roses, Fruit Trees, and Nursery Stock*.  
Frank Law, Oldham Road, Rochdale.—*Catalogue of Carnations, Picotees*, &c.

J. Schwartz, Lyon, France.—*Catalogue of Roses*.  
Fisher, Son & Sibray, Handsworth, Sheffield.—*Catalogue of Fruit, Forest and Ornamental Trees, and Shrubs*.



## TO CORRESPONDENTS

All correspondence should be directed either to "THE EDITOR" or to "THE PUBLISHER." Letters addressed to Dr. Hogg or members of the staff often remain unopened unavoidably. We request that no one will write privately to any of our correspondents, as doing so subjects them to unjustifiable trouble and expense.

Correspondents should not mix up on the same sheet questions relating to Gardening and those on Bee subjects, and should never send more than two or three questions at once. All articles intended for insertion should be written on one side of the paper only. We cannot reply to questions through the post, and we do not undertake to return rejected communications.

**Leaving a Situation (J. K. D.).**—In the absence of any special arrangement to that effect you cannot claim the expenses for your journey.

**The Mammoth Gourd (M. C.).**—It can be cooked in various ways—in soup, pies, &c., and most works on cookery give directions as to the best methods of preparing it.

**Insects on Poplar Leaves (C. M. S.).**—The insects sent on the Poplar leaves are the larvæ of a Sawfly, *Tenthredo Populi*, an insect allied to the familiar destroyers of the Gooseberry and the Turnip, but they are feeding later than usual, or possibly a second brood has hatched owing to the long summer.

**Levelling and Relaying Turf on Lawn Tennis Ground (F. T. D.).**—Much depends on the nature of the ground and the consequent amount of work required. If it be only taking off the turf, the levelling being such as will not occasion more work than is entailed in ordinary digging or trenching, and relaying with the needful heating, the 3d. per square yard is a fair price, or, if there is much wheeling, then 4d. to 6d. per square yard. Of course, those prices are for good work, and unless it be done properly it will ever be a source of trouble.

**Compost for Vine Border (F. H.).**—"Black peaty turf" should have a sixth of old mortar rubbish, a fifth of road scrapings, and a fourth of marly clay mixed with it to form a suitable compost for the Grape Vine. The clay must be chopped small, the old mortar rubbish be freed of laths and other bits of wood, and the road scrapings free of the roots of coarse weeds. Use manure on the surface only as a mulch.

**Dr. Hogg and Royal George Peaches (Idem).**—Dr. Hogg is one of the best second-early Peaches, the tree being an excellent grower and bearer, and the fruit is of good size, highly coloured, and though firm in the flesh is rich and full-flavoured. Royal George is undeniably one of the best-flavoured if not the best of the midseason Peaches. Perhaps their want of flavour this year is caused by overcropping, accelerated by the drought, and consequently lack of support, which timely and judicious thinning of the fruit, mulching, watering, and feeding with liquid manure would have prevented. Overcropping is the greatest drawback to full-flavoured fruit.

**Samphire (P. T., Sussex).**—The botanical name of this plant is *Crithmum maritimum*, and it is included in the natural order Umbelliferae. It grows abundantly on some of the rocky cliffs of the British coast, and on the rocky seashore. The whole plant is odorous, with a piquant, aromatic, and slightly saline taste. The entire plant and its thick fleshy leaves make an old-fashioned and excellent pickle, with vinegar, which forms an excellent condiment, and is considered very diuretic. In some of the markets at seaside towns this is frequently sold as a pickle, and we have seen abundance of it in the Brighton market, where you could readily procure it.

**Lilies of the Valley Outdoors (M. C. B.).**—An open situation should be chosen, the soil being well manured, and stirred as deeply as the good soil allows. They succeed in any good loam, but preferably in one containing decayed vegetable matter, such as leaf soil, the most suitable soil being alluvial. Any good garden soil will grow them well, only if the soil be light it must be made firm, but a strong loam will not need firming. Afford a good mulch of manure or leaf soil in autumn, and supply liquid manure during summer, not allowing them to become dry, as they are moisture-loving plants. It is poverty of soil that causes them to grow so indifferently, which is accelerated by allowing them to become crowded.

**Cropping Peach Trees (T. C.).**—1, One fruit to every square foot of surface—i.e., wall or trellis—covered by the trees, is ample in order to ensure the fruit attaining the highest perfection and not unduly taxing the vital forces of the trees. This applied to your trees represents about ten dozen per tree, whereas your "full crop" is sixteen to twenty dozen—nearly twice as much as the trees ought to bear in order to secure fruit of the largest size, the finest colour, and the fullest flavour. 2, The reduction of fruit should take place annually, and not at intervals. One year's overcropping may impair its vigour and capability of bearing for two or more years. 3, The best means of securing the finest fruit and the longest vitality is cleanliness, keeping the trees free from insect and fungoid pests, feeding by surface mulching and due supplies of water or liquid manure. Expose the foliage to light and air by thin in preference to close training, so that the food supplied may be properly assimilated.

**American Blackberries—Black Hamburg Grapes not Colouring (F. J.).**—There are 504 square yards in a rod, pole, or perch; 40 rods 1 rood; and 4 roods or 4840 square yards 1 statute acre. Blackberries

require to be treated similarly to Raspberries, the canes that have borne fruit being cut out and young strong ones of the current year trained in their places, cutting out the weak so as to give more encouragement to the fruiting canes, as well as securing strong canes for the succeeding crop. Black Hamburgh Grapes sometimes do not colour fully, which is usually a consequence of overcropping, though it may arise from grossness and deficient ripening. When it arises from overcropping, the Vines being otherwise in good condition, the Grapes, though red, are good in flavour but devoid of that sprightliness so esteemed in well-finished examples of Black Hamburgh. The flesh, too, is not nearly so firm in the "red" as in the black, and they will not keep so long. Cutting the Grapes as they ripen will certainly assist those that are not ripe, but it will not help them to colour.

**The Nectarine Peach (W. W. B.).**—The Nectarine Peach was noticed for the first time in the "Gardeners' Year-Book" for 1868. The fruit is large, and is remarkable for being terminated by a nipple, like Téton de Venus and A Bec. There is a little down on the skin. The skin is yellow, and with a bright mottled red on the side next the sun; the sun're well defined, particularly near the nipple. The flesh is semi-transparent, as is the case with almost all Mr. Rivers' seedlings, and with a brilliant red stain round the stone, from which it separates, leaving some rings behind it. It is melting, very richly flavoured, and with a fine racy smack. The stone has a tendency to split, and the kernel has a very mild bitter taste. It ripens in the middle of September. Flowers large; glands

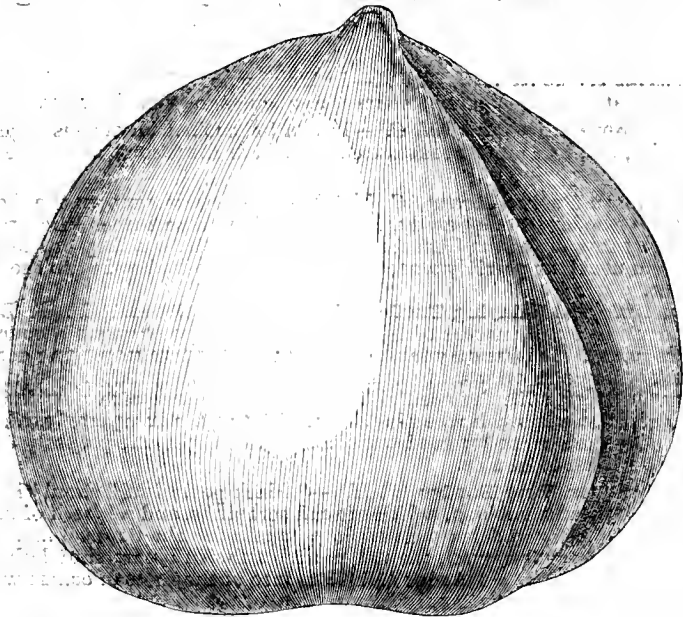

Fig. 30.

kidney-shaped. The variety was raised by Mr. Rivers from seed of a variety named Grand Noir, imported from Holland. Some find it of rather weakly habit out of doors.

**Walnut Trees Coming into Bearing (J. W. Newton).**—There is a great difference in the soil and locality in respect of the age at which the trees come into bearing. Trees on silicious and calcareous soils produce fruit sooner than trees on rich and moist soils. The mode of raising also affects the age at which trees bear; those grafted come into bearing in about half the time that those raised from seed require. Trees of the common Walnut 6 to 10 feet high, and grown thinly as well as frequently transplanted, will usually bear in three to five years after being placed in their permanent quarters. The earliest-bearing is Dwarf Prolific, which bears abundantly at 6 feet high, affording good-sized well-flavoured nuts, and is a variety that reproduces itself from seed. It, however, requires a warm soil and situation. Ordinary varieties of the common Walnut which are usually raised from seed do not afford profitable crops until of the age you name—viz., thirty or forty years. The only thing likely to cause trees of that age to bear is to root-prune them, which should be done as soon as the foliage turns yellow or is beginning to fall. In order to secure more fertile trees, scions should be taken from trees that are noted for fertility and good quality, grafting the stocks from seed so as to secure earlier bearing and a certain character. For elevated and northerly localities the Yorkshire is very desirable.

**Names of Fruits.**—The names and addresses of senders of fruit to be named must in all cases be enclosed with the specimens, whether letters referring to the fruit are sent by post or not. The names are not necessarily required for publication, initials sufficing for that. Only six specimens can be named at once, and beyond that number cannot be preserved. (S. Taylor.—1, Lewis' Incomparable; 2, Norfolk Bearer; 3, Gravenstein; 4, Manks Codlin; 5, Manks Codlin; 6, Nelson Codlin. (A. Y. Z.).—1, Van Mons-Léon Leclerc; 2, Beurré Kennes; 3, Fondante d'Automne; 4, not known. Apples: 1, Pomme de Neige; 2, Fearn's Pippin. (R. P. S.).—1, Golden Pearmain; 2, Blenheim Pippin; 3, not known; 4, Mother Apple; 5, Gloria Mundi; 6, Court-pendu-plat. (J. L. Peach).—1, Althorp Crasanne; 2, Urbaniste; 3, Beurré Bosc; 4, Duchesse d'Orleans; 5, Chaumontel; 6, not known. (John Coppin).—1, Lord Suffield; 2, Brad-dick's Nonpareil; 3, Fearn's Pippin; 4, Dutch Codlin. (Jam's Birch).—Trumpington. (J. Mooridge).—1, Forelle; 2, Beurré Superfin; 3, East'r Beurré; 4, Chaumontel; 5, Doyenné du Comice; 6, Vicar of Winkfield. (F. W.).—1, Theodore Van Mons; 2, Small Vicar of Winkfeld; 3, Noveau Poiteau; 4, Beurré Langlier; 5, London Pippin; 6, Miushall Crab. (B. L.).—1, Doyenné du Comice; 2, G'ou Morceau; 4, probably Passe Colmar; 4, Eyewood. (P. H. Wright).—1, Gloria Mundi; 2, Flower of Kent; 3, New Hawthornden; 4, Ord's. (A. H.).—The Pear is Williams' Bon Chrétien, and the specks are characteristic of the variety.

**Names of Plants.**—We only undertake to name species of plants, not varieties that have originated from seed and termed florists' flowers. Flowering specimens are necessary of flowering plants, and Fern fronds should bear spores. Specimens should arrive in a fresh state in firm boxes. Slightly damp moss or soft green leaves form the best packing, dry cotton wool the worst. Not more than six specimens can be named at once. (J. R. S.).—1, Sedum spectabile; 2, Aster Amellus bessarabicus; 3, Pyrethrum uliginosum. (W. R.).—1, Grevillea robusta; 2, Hoya Paxtoni; 3, Cuphea platycentra; 4, Lobelia cardinalis; 5, Asplenium marinum.

COVENT GARDEN MARKET.—OCTOBER 5TH.

HEAVY supplies of Cobs reaching us, causing prices to fall. No change otherwise. FRUIT.

	d.	s.	d.		s.	d.	s.	d.
Apples, 1/2 sieve	1	6	3	6	Oranges, per 100	6	0	12
Nova Scotia and Canada barrel	0	0	0	0	Peaches, dozen	2	6	6
Cherries, 1/2 sieve	0	0	0	0	Pears, dozen	1	0	1
Cobs, 100 lbs.	45	0	50	0	Pine Apples, English, per lb.	1	6	0
Figs, dozen	0	3	0	6	Plums, 1/2 sieve	1	6	2
Grapes, per lb.	0	6	2	6	St. Michael Pines, each	3	0	5
Lemons, case	10	0	15	0	Strawberries, per lb.	0	0	0
Melon, each	0	6	1	0				

VEGETABLES.

	s.	d.	s.	d.		s.	d.	s.	d.
Artichokes, dozen	1	0	2	0	Lettuce, dozen	0	9	0	0
Asparagus, bundle	0	0	0	0	Mushrooms, punnet	0	6	1	0
Beans, Kidney, per lb.	0	3	0	0	Mustard and Cress, punt.	0	2	0	6
Beet, Red, dozen	1	0	2	0	Onions, bunch	0	3	0	6
Broccoli, bundle	0	0	0	0	Parsley, dozen bunches	2	0	3	0
Brussels Sprouts, 1/2 sieve	0	0	0	0	Parsnips, dozen	1	0	0	0
Cabbage, dozen	1	6	0	0	Potatoes, per cwt.	4	0	5	0
Capiscums, per 100	1	6	2	0	" Kidney, per cwt.	4	0	0	0
Carrots, bunch	0	4	0	0	Rhubarb, bundle	0	2	0	0
Cauliflowers, dozen	3	0	4	0	Salsafy, bundle	1	0	1	6
Celery, bundle	1	6	2	0	Scorzoneria, bundle	1	6	0	0
Coleworts, doz. bunches	2	0	4	0	Seakale, basket	0	0	0	0
Cucumbers, each	0	4	0	8	Shallots, per lb.	0	3	0	0
Endive, dozen	1	0	2	0	Spinach, bushel	3	0	4	0
Herbs, bunch	0	2	0	0	Tomatoes, per lb.	0	4	0	6
Leeks, bunch	0	3	0	4	Turnips, bunch	0	4	0	6

PLANTS IN POTS.

	s.	d.	s.	d.		s.	d.	s.	d.
Aralia Sieboldi, dozen	6	0	12	0	Fuchsia, dozen	0	0	9	0
Arbor vitae (golden) dozen	6	0	9	0	Geranium (Ivy), dozen	0	0	0	0
" (common), dozen	0	0	0	0	" Tricolor, dozen	0	0	0	0
Asters, dozen pots	3	0	6	0	Gladiolus	4	0	6	0
Azalea, dozen	0	0	0	0	Hydrangea, dozen	9	0	12	0
Begonias, dozen	4	0	9	0	Lilies Valley, dozen	0	0	0	0
Capiscums, dozen	6	0	9	0	Lilium lancifolium, doz.	12	0	18	0
Cineraria, dozen	0	0	0	0	" longiflorum, doz.	0	0	0	0
Creeping Jenny, dozen	0	0	0	0	Lobelia, dozen	0	0	0	0
Dracæna terminalis, doz.	30	0	60	0	Marguerite Daisy, dozen	6	0	12	0
" viridis, dozen	12	0	24	0	Mignonette, dozen	3	0	6	0
Erica, various, dozen	9	0	18	0	Musk, dozen	0	0	0	0
Euonymus, 1/4 var., dozen	6	0	18	0	Myrtles, dozen	6	0	12	0
Evergreens, in var., dozen	6	0	24	0	Palms, in var., each	2	6	21	0
Ferns, in variety, dozen	4	0	18	0	Pelargoniums, dozen	6	0	12	0
Ficus elastica, each	1	6	7	0	" scarlet, doz.	3	0	9	0
Foliage Plants, var., each	2	0	10	0	Spiræa, dozen	0	0	0	0

CUT FLOWERS.

	s.	d.	s.	d.		s.	d.	s.	d.
Abutilons, 12 bunches	2	0	4	0	Lilies, White, 12 bunches	0	0	0	0
Anemones, 12 bunches	0	0	0	0	" Orange, 12 bunches	0	0	0	0
Arm Lilies, 12 blooms	3	0	6	0	Marguerites, 12 bunches	2	0	6	0
Asters, 12 bunches	2	0	6	0	Mignonette, 12 bunches	1	0	3	0
" French, bunch	1	6	2	0	Myosotis, 12 bunches	1	6	3	0
Bouvardias, bunch	0	6	1	0	Narciss, 12 bunches	0	0	0	0
Camellias, blooms	0	0	0	0	" White, English, bch.	0	0	0	0
Carnations, 12 blooms	1	0	2	0	Pansies, 12 bunches	0	0	0	0
" 12 bunches	4	0	6	0	Peas, Sweet, 12 bunches	1	6	3	0
Cornflower, 12 bunches	1	6	3	0	Pelargoniums, 12 trusses	0	9	1	0
Dahlia, 12 bunches	2	0	4	0	" scarlet, 12 trusses	0	3	0	6
Daisies, 12 bunches	2	0	4	0	Pinks, White, 12 bunches	0	0	0	0
Encharis, dozen	2	0	4	0	" various, 12 bunch	2	0	4	0
Gardenias, 12 blooms	2	0	5	0	Poinsettia, 12 blooms	0	0	0	0
Gladiolus, 12 sprays	1	0	1	6	Primula (single), bunch	0	0	0	0
Hyacinths. Roman, 12 sprays	0	0	0	0	" (double), bunch	0	9	1	0
Iris, 12 bunches	0	0	0	0	Polyantbus, 12 bunches	0	0	0	0
Lapageria, white, 12 blooms	1	6	3	0	Ranunculus, 12 bunches	0	0	0	0
Lapageria, coloured, 12 blooms	1	0	1	6	Roses, 12 bunches	2	0	6	0
Lilac (white), French, bunch	0	0	0	0	" (indoor), dozen	0	9	1	0
Lilium longiflorum, 12 blooms	2	0	3	0	" Tea, dozen	1	6	3	0
Lilium lancifolium, 12 blooms	0	6	1	0	" red dozen	0	0	0	0
					" de Moix, 12 bunches	0	0	0	0
					Stephanotis, 12 sprays	2	6	4	0
					Tropeolum, 12 bunches	0	0	0	0
					Tuberoses, 12 blooms	0	6	1	0
					Tulips, dozen blooms	0	0	0	0
					Violets, 12 bunches	1	0	1	6



MICHAELMAS

IN a review of the farming year the drought and its effect upon crops is the reverse of a pleasant reminiscence.

On many a farm, especially where the soil is thin, spring corn, roots, and pasture were all seriously affected by it, pasture especially becoming so parched that the hay crop was much below the average, and there was little, if any, growth upon it subsequently till after harvest. Now this was just one of those untoward things which upset all calculations, and in many an instance compel a farmer to sell his cattle and sheep prematurely at unremunerative prices.

Let us see now if it is possible by any improvement in practice so to combat, or rather forestall, such periods of drought by improved methods of culture as to avoid having to incur losses that must cripple our efforts, and which may lead to positive ruin. It must certainly be owned that hitherto in the principal corn-growing districts there has been little, if any, attempt at the cultivation of permanent pasture. Upon every farm there are a few meadows, but the herbage is generally of an inferior character, and there is frequently a large per-centage of worthless perennial weeds. Because noxious weeds are so common to pasture, it by no means follows that they should remain in it. It is customary upon some farms that the shepherd shall devote spare time to spudding Thistles and Docks and mowing Nettles. Far better would it be if he were set to gradually uproot such pests and so eradicate them. To get rid of Thistles we have only to pull them up when the soil is sufficiently softened by rain, and there is an end of them. The destruction of Nettles and Docks is more laborious, because they must be dug or grubbed up; but then the work is done with, and there will be no subsequent occasion for the periodical mowing and spudding of growth which is now so common.

The application of manure to pasture is another matter to which we have frequently called attention. We have repeatedly had proof in our own practice that pasture maintained in a high state of fertility invariably affords a full crop of hay, and suffers much less from a hot dry summer than poor pasture, or that which has no systematic cultivation. It is altogether a mistake to suppose that the grazing of a certain number of sheep or cattle upon pasture will enrich it sufficiently. If sheep are passed over it in folds and are well fed they will do so, but folding is a very different matter from turning them loose upon it to ramble at will. In even a brief reference to this matter, one is tempted by a sense of its importance to enter upon details of cultivation which experience has shown cannot be neglected with impunity. It will, however, suffice now if we mention that good work may be done at once by draining wet pasture, and sheep-folding during autumn or winter will ensure an early and strong growth in spring. If sheep cannot be had then give a dressing of home-mixed chemical manure next February, and it will be found that the money so spent is a very profitable investment.

Green crops on arable land proved very useful. We first had the sheep in folds on Rye, which was eaten off so closely that the land was quite bare when they left it; so abundant was our supply of other green food that we did not require the strong second growth of Rye which the folding induced, and it was left for seed and straw. This was harvested in excellent condition, threshed early, and the seed not required for sowing was sold not quite to our satisfaction, for it was excellent seed for which we should have had to pay 2s. per quarter, but we could only obtain 2s. from a corn merchant, who thus got a profit of 3s. per quarter. When corn is so purchased and sold at once, without being taken into the merchant's

warehouse, he certainly gets what upon the face of it appears to be an undue amount of profit, but in buying he has always to take into account the possible contingency of storage and a slow sale.

Sainfoin gave us plenty of sheep food after the Rye, and the lambs did remarkably well upon it. We have harvested a good stock of seed from much of the second growth, which seed will not be milled; but sown in the husk at the rate of four bushels to the acre with a corn crop next spring. Our young layers of Sainfoin are a good strong plant now, and we intend sowing much more of it and less of Red Clover upon our heavy land farms next spring. Red Clover gave an excellent first crop, much of which was made into stover, but some was eaten off by sheep, and the second growth saved for seed. It was only where the sheep went that we had a fairly strong second growth, for drought checked growth so much after the mowing that it was stunted and unfit either for seed or stover.

(To be continued.)

#### WORK ON THE HOME FARM.

What sowing has so far been done easily and well, and we have decided to have no more corn threshed on the heavy land farms until the whole of the winter corn is sown. We have sent seed of Oakshott's D-fiance Red Wheat to all of our farms for trial next season. We had a small field of it this season at the home farm, and another at an off farm, and the yield and weight are sufficiently good to induce us to give it a further and more extensive trial. We have only threshed a little Wheat as yet for food; the surplus quantity of that was sold, and we got 2s. 6d. a quarter more for Webbs' Giant White than for White Chaff Red. The difference in price is not a large one, but is still enough to be worth having; £12 10s. in every hundred quarters of Wheat will make a material difference in our balance sheet at the end of the year. Winter Beans have been sown by fastening a spout drill to a plough, other ploughs following without drills, so as to keep the rows far enough apart. This is a very satisfactory way of sowing Beans much followed by Suffolk farmers, the ploughing and drilling being done at one and the same time, and there is almost always a good strong plant from Beans so sown, while the rough surface of the land affords some protection to it during winter. We called attention last winter to the high value of Beans for fattening cattle, better results being obtained by a judicious dietary of Beans, chaff, and roots than from one into which oilcake enters largely. We strive to make farms self-supporting in this matter so far as we can do, for we hold that a heavy expenditure for cake should be avoided.

The prevalence of swine fever has led to the issue of printed forms, with spaces left for every farmer to make a declaration that his farm is, and has been, free from infection for a given period of time. This is a step in the right direction, which may have some effect in checking the spread of the fever, but it will do little more if farmers do not help themselves by seeing that pigs are kept in such a cleanly condition as to ensure good health. The spread of swine fever is simply an outcome of the careless, care-going practice of keeping them in a filthy condition and feeding them with equally filthy food.

#### FARMERS AND THEIR CATTLE.

At a time when our pastures are yielding very little food, and our hay and Turnip crops are from one-third to one-half below an average, with the eventual prospect before us of a great scarcity before next May of feeding stuffs for our cattle, perhaps I shall do my fellow farmers a service by calling their attention to a cheap food adjunct, which is at present available for us, and which at one time was highly valued—I allude to that of green malt. Since the malt duty was removed, every farmer can make malt for himself free from all restrictions, and the cost to him of making it is a nominal one. Formerly very much was thought of malt as a feeder for all stock, and it is especially good for cows, as they will upon it, with bran and other food, produce plenty of rich sweet milk all the winter through; sheep, beasts, and horses all thrive and fatten upon a mixture of it and other foods, but of late years it has not been much used, as its cost has been higher than other feeders. Malt is termed green when the roots and stem of the Barley from which it is made are sufficiently grown for it to be put upon the kiln to be dried. It is also at this stage of its growth that it is of the most value as a feeder—it being found that green malt gives better feeding results than dried malt—and, as I will show later on, every farmer can easily make this sort of malt himself, almost without any manufacturing cost.

As I have already said, the general use of green malt has been curtailed by its comparative expensiveness, but this objection does not exist at the present. There is no better Barley for making this malt from than that imported from Russia, being less liable to mould, and singular to say, this sort of Barley has never before been so plentiful nor so cheap



as it is at the present time—in fact, it can be got at the chief ports at 6d. per stone or £1 per ton, which is below the price of hay, undecorticated cotton cakes and bran; in fact, feeding Barley is at present more than  $1\frac{1}{2}$ — $1\frac{1}{2}$  penny per stone, or £1 per ton cheaper than Maize, and is not very much higher in price than straw in some parts of the country. No doubt this unprecedented cheapness of feeding Barley will cause it to be used largely, in its unconverted state, either unground or ground into meal, along with Turnips and other food, but I prefer it when converted into green malt, and for the benefit of those farmers who are inclined to follow my example in this respect I may say that the process of conversion is as follows:—

The Barley must first be steeped overhead in water (allowing it room to swell) about forty-eight hours, and this can be done in any tank or large tub or casks which may be available (the latter can also be bought of any cooper for a few shillings each), into which a large plug-hole should be made at the side, as near the bottom as possible, and over the inside of the plug-hole should be fixed some perforated zinc (which can be got at any ironmongers) so that when the plug is taken out, the water may be drained off through the zinc and plug-hole, and the Barley left behind. It is a good plan to let the perforated zinc enclose a larger space than is occupied by the plug-hole, so as to let the water drain to it more quickly. When the Barley has been steeped forty-eight hours and the water drawn off, place it thickly upon a floor, say 2 feet thick, and let it remain there until some warmth is developed; it must then be thinned down to say 6 inches, and must be daily turned over until it strikes out its roots; as soon as these have grown a little and show signs of withering, the Barley should be sprinkled with a watering-can and the turning continued until the acrospire—or what would be the stalk if the Barley were planted—has forced its way well up the back of the Barley under the skin; when this is accomplished, the Barley has been converted into green malt, and is at the stage of manufacture which is of most value to the farmer for feeding purposes. The whole operation from first wetting till ready for use will occupy from ten to twelve days. As regards the floor for growing Barley upon, a concrete one is the best, but either brick or wood will do, only in the latter case more moisture will have to be added whilst the Barley is upon it. A wooden floor may also be cheaply covered with galvanised iron sheets, and is then even better than a concrete floor. It follows that the quantity steeped or wetted every forty-eight hours should be calculated according to what is required for two days' consumption; and any farmer who may wish for further information respecting the process can no doubt obtain it from his nearest neighbouring malster. Mr. W. J. Harris, of High Hampton, Devon, has lately contributed a long article to the newspapers, giving calculations showing that the deficiency in this year's crops of Oats, hay, Turnips, and straw, amounts to 14,600,000 tons, and this estimate is also concurred in by other authorities. Mr. Harris further calculates that this deficiency can be made up by using 12,000,000 qrs. of feeding Barley, and it is certainly fortunate for us that this article is at present cheaper than all other feeding corn, and that it can be bought at as low a price as hay and undecorticated cottonseed cakes.

In case the rain should now cause a sharp growth of succulent grass it will be found advantageous to give dry Barley to stock to prevent scour.—J. SHAW, *Walkington Towers Farm, Beverley.*

REFERRING to this subject the agricultural correspondent of a daily paper remarks—"That cattle do well on malt—whether 'green' or dried—there is no doubt, but Mr. Shaw has not the sanction of science for its being an economical form in which to use Barley. A certain quantity of feeding material is lost in the chemical changes and evaporations which occur during germination, and it has never yet been shown that the malt resulting from a quarter of Barley is sufficiently superior in intrinsic feeding properties to raw Barley to atone for the actual loss that takes place in conversion. Unless the malt from a quarter of Barley has greater fattening or milk-producing powers than is possessed by the original quarter of unmalted Barley, the expense of converting into malt must be regarded as an economical loss. The experiments of Sir John Lawes and Dr. Gilbert controvert the idea that there is any such gain in nutritive value as to balance the loss in germination and the cost of treatment. If malt has any superior value over raw Barley as a food, it is probably a condimentary value, and no doubt an allowance of green malt, mixed with such unpalatable food as chopped straw, for instance, might tempt an animal to enjoy rations which he would otherwise only tolerate. It is sometimes argued that if a beast is healthy condiments are superfluous and unnatural, but it is often forgotten that the whole processes of stall-feeding and fattening an animal for the butcher are more or less unnatural, and there are circumstances under which, even for healthy cattle in good condition, condiments have a value, and valuable as are its feeding properties, it is as a condiment, rather than as a food, that we are inclined to class malt. A small proportion of malt, whether 'green' or kiln-dried, will flavour a good deal of Barley or other food, and it is in this way, rather than as a chief constituent of diet, that malt is probably to be most economically used. The fact that notwithstanding the abolition of the malt duty, hardly any farmers malt the Barley which they give to stock is in itself a very pregnant fact. It was at one time thought that the abolition of the malt tax would confer on farmers a great boon by giving them freedom to malt grain for their feeding boxes. But experience since shows either that the boon, if such it is, is very poorly appreciated, or that practice in this matter endorses the dictum of science. Quite apart, however, from the malting question, Mr. Shaw is right in calling attention to the cheapness and abundance of foreign Barley."

## TRUE AND FALSE HESSIANS.

In re the Hessian fly, we are now discovering that we have to deduct a percentage from the reports of its appearance, sundry other flies having been mistaken for *Cecidomyia destructor*, as was likely to happen. To take one instance, the supposed new foe turned out to be the ribbon-footed corn fly or the gout fly, so styled from the effect produced on the stem by the attack of the larva or grub. Though this fly occurs on various cereals it shows a preference for Barley, and did much mischief, chiefly in North England, during the summers of 1841 and 1846. The fly, *Chlorops tæmatus*, is small, about an eighth of an inch long, and stumpy in form, very distinctly striped with black on the body; it generally lays its eggs on the rudimentary ear while the plant is young. Generally the ear is produced, but the grains are few and often misshapen, the plant assuming a dwarfed aspect, having the stem somewhat curved and puffy at the joints. On opening up one attacked we perceive the long blackish furrow made by the larva, at the bottom of which the pupa lies till matured. It is a pest that evidently selects those blades growing upon moist land, and seldom occurs upon chalky soils. To supply the Barley with abundant nutriment is one of the preventive means, hence the application of superphosphate or of the nitrate of soda has been advised, salt and caustic lime have also been used. The efficacy of these is rather doubtful. Good drainage is important; it is stated that sometimes thousands of the flies secrete themselves in stacks when the insect has bred in fields near; so these should be looked after. A backward crop is always in peril, and on the earliest signs of the presence of this grub infected specimens should be sought out and removed.

It was quite natural that the attack of the corn sawfly should in some cases be taken for that of the Hessian insect, as by the operations of both species the straw falls, but differently. With the Hessian fly, however, the stem bends at about the first or second joint from the soil, while from the effects of the corn sawfly the stem breaks off near the ground, in fact so near that afterwards the part left in the soil is not easy to find. This fly, *Cephus pygmaeus*, occurs every year, probably in about the same numbers; it seems to have been more noticed during 1887, because the reports relating to the Hessian fly have led to careful observation of the corn crops. The larva feeds also upon the stems of grasses, but it has never been of serious injury to cereals in this country; on the Continent it appears to be more prolific. This fly is nearly double the size of the Hessian insect, and it is four-winged, marked with black and yellow, and fond of flying in the sunshine; its emergence takes place about May or early in June, when the female insect distributes her eggs, placing one upon each plaut. The maggot is legless, pale yellow, with a brown horny head, armed with jaws strong enough to enable it to eat through the straw just as it becomes adult. It then remains in the pupa state through the winter, hidden within the fragment of the stem that is buried. Hence, though burning the stubble after reaping destroys the insect, to do this most effectually it is necessary to loosen and raise the soil somewhat, or a part of the pupæ will escape.

It is possible that some persons who have failed to read attentively the particulars given concerning the habits of the Hessian fly, seeing a swarm of midges about the corn on a June evening, may have supposed they were the enemy. These tiny flies belong to the species *Cecidomyia tritici*, and their larvæ feed upon the young ear, being popularly known as "red maggot."—ENTOMOLOGIST.

## METEOROLOGICAL OBSERVATIONS.

CAMDEN SQUARE, LONDON.

Lat. 51° 32' 40" N.; Long. 0° 8' 0" W.; Altitude, 111 feet.

DATE.	9 A.M.					IN THE DAY.				Rain	
	Baromet. ter at 39° and Sea Level.	Hygromet- ter.		Direction of Wind.	Temp. of soil at 1 foot.	Shade Tem- perature.		Radiation Temperature.			
		Dry.	Wet.			Max.	Min.	In sun.	On grass		
1887. Sept.—Oct.	Inches.	deg.	deg.	deg.	deg.	deg.	deg.	deg.	deg.	In.	
Sunday .....	25	31.317	48.9	45.2	S.	54.9	62.5	38.4	100.2	31.6	—
Monday .....	26	29.871	55.6	53.1	S.W.	54.6	59.7	49.3	72.9	44.7	0.112
Tuesday .....	27	29.496	51.7	49.2	E.	54.8	59.8	47.2	93.3	44.6	0.013
Wednesday .....	28	29.296	45.3	43.1	N.W.	54.2	58.2	40.6	102.3	37.2	—
Thursday .....	29	29.410	47.5	43.9	N.	52.8	59.8	34.3	97.8	31.4	0.011
Friday .....	30	29.783	49.2	46.0	N.	51.8	56.4	39.1	92.5	34.3	0.448
Saturday .....	1	30.116	53.7	50.2	N.	52.1	60.5	45.4	103.4	39.8	—
		29.752	59.3	47.2		53.6	59.5	43.0	94.6	37.7	0.184

### REMARKS.

- 25th.—Fine and bright, with warm sunshine.  
 26th.—Dull, with occasional spots of rain; heavy rain at night.  
 27th.—Fine, bright morning; clouded over in afternoon; shower about 6 P.M.; fine evening.  
 28th.—Bright; fresh and cool.  
 29th.—Fine, bright morning; cloudy afternoon; shower about 6 P.M.; bright evening and night.  
 30th.—Bright morning; cloudy with spots of rain at noon; showery afternoon; clear fine night.  
 October 1st.—Bright early; cloudy with spots of rain from noon to 1 P.M., then again fine and generally bright.

A pleasant autumnal week; variable, but with a good deal of sunshine. Temperature about 4° below that of the preceding week, and 3° below the average.—J. SYMONS.



## COMING EVENTS

13	TH	Hardy Fruit Show at Manchester (three days).
14	F	
15	S	
16	SUN	19TH SUNDAY AFTER TRINITY.
17	M	
18	TU	
19	W	

### NOTES ON GRAFTING. PEARS AND APPLES.

**F**ANCIFUL accounts of the results of grafting were given by some of the ancient writers, but cultivators of the present time smile at descriptions of black Roses produced by Black Currants as stocks, red Apples on the Elm, or red Oranges on the Pomegranate. It is also well understood that the marvellous compound trees said to bear Pears, Grapes, Figs, Plums, &c., were simply tricks to impose upon the credulous, and even those who should have been better informed seem to have fallen into the snare. But though justly regarding these as idle stories, and though a wonderful advance has been made in the practical results of grafting as applied to fruit trees, it is still an admitted fact that much remains to be done before the information obtained can be classified or thoroughly understood. The chief cause of this seems to be the want of recorded experiments extending over a number of years conducted both practically and scientifically. Numbers of isolated experiments have been made, the results of which are never conveyed to the world, and the few that have been published are so widely scattered as to be consequently inaccessible to those whom they would most interest. If some of the nurserymen who trade largely in fruit trees, or amateur pomologists, would take such a matter in hand they would do horticulture an important service.

The interesting note in the Journal recently respecting a Pear tree grafted on an Apple stock suggested these observations, and unquestionably many readers could contribute much information bearing on the subject generally. It has been abundantly proved that success in grafting can only be obtained when there is a natural affinity between the stock and scion, and the more nearly related they are the more readily is the union effected. But there are numerous instances of grafting being successfully accomplished not only between species of the same genus, but even between those of different genera. For example, the Pear has been worked on several species of *Cratægus*, and these are well defined distinct genera. The *Cotoneaster* has also been grafted upon *Cratægus oxyacantha*, and the Medlar can be worked on the same stock successfully. Another example often referred to as showing that very distinct plants can be united by grafting is the case of the *Garrya elliptica* grafted on the *Aucuba*, which by most botanists are classed in different families, though later authorities have placed them together in the Dogwood family. They are at least extremely distinct in appearance and manner of flowering. Amongst the Coniferæ and other ornamental plants many examples are afforded of grafting being effected between species of different genera, and in some families like

the Cactea, certain types as the *Epiphyllums* freely unite with such distinct forms as the *Pereskias* and *Cereuses*. In most instances, however, these results point to a close relationship, and the botanist may occasionally obtain a hint from the horticulturist where the determination of generic limits is difficult.

Amongst ornamental plants grafting or budding has been extensively employed during the present century with great advantage, but the most important results have been those secured by the fruit cultivators. We know that grafting has been practised in Britain for over 300 years, but it is only within the present century that any real progress has been made in the selection or adaptation of stocks to particular situations and soils. The Pear and the Apple as constituting the two most important of our hardy fruits have especially engaged the attention of cultivators or experimentalists, and now the owner of a garden upon almost any soil can, by a judicious selection of trees upon suitable stocks and due attention, secure crops of useful fruit without having to wait a number of years before they come into bearing. Two valuable records recently issued—namely, the Royal Horticultural Society's Report of their Pear Conference in 1885, and the Royal Caledonian Horticultural Society's Report of the Apple and Pear Congress in the same year, contain much important information upon the respective value of the different stocks employed for Apples and Pears. They are particularly useful as the first attempts to present a general review of the varying results in widely separated districts, and though the respective editors have not attempted to make any general deductions from the numerous facts chronicled, there are several points that are very noticeable. With regard to the Pear a large majority of growers have proved the advantages of the Quince stock, and in nearly every case the finest fruits were those from trees on this stock. An excellent example of this was shown in the collection of ninety varieties from Mr. W. Wildsmith, gardener to Viscount Eversley, Heckfield Place, Winchfield, and the remarks accompanying the exhibit were so much to the point that they were reproduced on page 154, August 25th, 1887.

As a general rule the Pear stock is recommended for light soils, and where it is desired to form large trees; some of the exceptions are, however, worthy of note. Mr. G. T. Miles, Wycombe Abbey Gardens, for instance, had forty varieties of Pears from trees on the Pear stock, the fruits being good examples of their varieties. The soil is "dark peaty loam," the trees being planted in "good loam, 30 inches deep, beneath which a layer, 15 inches thick, of broken bricks is placed." The latter fact, no doubt, accounts to some extent for the success of the trees on a strong stock in such a damp soil. An example of Pear stocks being preferred in heavy soil is afforded at Madresfield Court Gardens, Malvern, whence thirty-seven large fruits were sent, and Mr. Crump remarked as follows:—

"Situation, 135 feet above sea-level, with very little shelter; aspect, open. Soil, strong loam, approaching to clay; subsoil, red marl, with gravel. Pears are largely cultivated on the free or Pear stock; they do remarkably well in the strong soil of this district so long as the roots are kept near the surface by systematic root-pruning, till the balance of fertility is struck, otherwise, if allowed to root down unrestricted into the wet, unkindly subsoil of strong marl, the fruit cracks and becomes spotted and worthless, the trees making gross wood, which does not ripen. Glou Morceau is one of the first to show distress. I do not infer that this root-pruning, however judiciously done, will always secure full crops, as spring frosts have to be taken into account. Our very finest Pears are grown on a west aspect wall."

It is commonly said that exceptions prove the rule, but such exceptions as these show how difficult it is to formulate generalities. As to the usefulness of the Quince as a stock for bush and pyramid trees in most gardens there can, however, be no question; they come into bearing quickly, are generally prolific, and are by no means short-lived when well treated. The late Mr. T. Rivers was a strong advocate for this stock for Pears, and assisted largely in its extension with considerable benefit to many owners of small gardens.

Double-grafting for Pear trees has not been so much practised in England as on the Continent, though some nurserymen have found it beneficial in the case of delicate varieties that do not succeed well direct on the Quince. The introduction of some hardy variety as an intermediary facilitates the matter, and fine fruits are thus obtained where considerable difficulty had been previously experienced. That fine old Pear, Gansel's Bergamot, has been found most satisfactory in this way, and Marie Louise also. Much more might, however, be done in this direction.

Judging by the Apple Report already mentioned, which gives the experience and opinions of over 250 practical men, the Crab stock is most generally satisfactory for Apples, and a number of very old trees are named as still fruitful and healthy. But some of the best specimens were from trees on the Paradise, and it appears that many of the others are orchard trees, for which the Crab is undoubtedly the most fitted. For smaller growing trees of the bush, pyramid, or cordon style of training are preferable on the Paradise.

It would take too much space to refer now to the other hardy fruits and their several stocks. The Apricot and Peach are particularly interesting, as they have been tried upon so many different stocks, but perhaps other readers can tell us something about these, together with the Plum and the Cherry.—C.

### OCTOBER FLOWERING PERENNIALS.

THE recent rains which followed the long-continued drought of the summer now passed has been conducive to the production of plenty of hardy flowers out of doors up to the present time; indeed, there is a wealth of flowers still, which but for the cold, chilly, and frosty nights occasionally experienced of late might lead one to believe that we are still in summer, though this is again contradicted by the appearance of many strictly autumn-flowering plants. I will point to some of the more worthy still in bloom as well as those which are fading.

I will first take the Sunflowers, of which there are five varieties still producing good flowers. These are *Helianthus multiflorus plenus*, *H. m. major*, *H. m. grandiflorus*. These three are still in excellent condition and promise a continuance of flowers for some time to come, and this notwithstanding that they have been producing abundance of flowers since July. The two other forms are *H. intermedius* and *H. rigidus latifolius*, the last named just passing out of bloom, while *H. rigidus* completed its flowering about three weeks since. The plant which I here allude to as *H. rigidus latifolius* is that generally sold as *H. japonicus*, but as there is no species whatever found in either China or Japan, there is no doubt that such a name is quite erroneous. These Sunflowers are beautifully adapted for the decoration of large borders, and their bold flowers are very handsome; for large vases or the like they are very pleasing. The *Gaillardias* are useful. A large bed planted in spring has given hundreds of their gaily coloured blossoms, which continue to expand as fresh as ever. Wonderfully varied, too, are these flowers; some are pure golden selfs, others light yellow selfs, and others again are aglow with shades of crimson and scarlet and a belting of gold to complete it. Such flowers as these cannot fail to become popular. They are so gay, so profuse, and so easily grown that no garden should be without a dozen clumps of these strikingly beautiful plants, which are quite unique for their wonderful combination of colour. For vase decoration under artificial light they are extremely effective.

The single *Pyrethrums* seem next to demand a passing word, and while they do not boast the array of colour which the *Gaillardias* assume, they are pleasing and highly interesting at this time. They close their flowers early in the afternoon (the florets drooping after the manner of some of the annual *Chrysanthemums*) and remain in this state till about 10 A.M., earlier or later according to the presence or absence of sun. In a cut state they are delightful, and by adopting special means in their culture they may be had with flowers equally large and handsome as in the height of their season. At present the most conspicuous colours are crimson lake, amaranth, various shades of rose, rosy blush, lilac blush, together with white and many shades of pleasing rosy lilac.

There are many which must be included in this short note, and among these just now *Leucanthemum maximum* and *Pyrethrum uliginosum* deserve special note as being useful and both having white flowers which are produced freely. The first-named is keeping up its flowering late, for it did not produce flowers with its usual freedom in summer on account of the parching heat. The latter is a strictly autumn flower, and very serviceable too at this time. The one great drawback respecting it appears to be the height which it attains—viz., 6 feet, but I have made it exactly half that height by cutting it to within 6 inches of the ground in the first week in June, afterwards pinching out the points of those breaks that would appear to take the lead, and at this height it makes a splendid bed. For those who require plenty of flowers when hardy flowers are swept away by frost I suggest growing it in pots plunged in the open ground and cut hard back as recommended, lifting them at flowering time for the decoration of the conservatory, or grown in this way it would make a fine companion plant for *Aster amellus bessarubicus* and *A. longifolius formosus*. These three would make a delicious autumn bed, placing the *Pyrethrum* as a centre with *Aster bessarubicus* next, and the latter forming the margin. This would make a pure white centre, with purplish blue next, and a margin of bright rose, lasting a long time in perfection.

For another plant with trusses of light pink flowers we must turn to *Sedum spectabile*, which attains to about 15 inches high, and has broad flattish heads of bloom. It is a very free bloomer and suited to dry hot positions, but is more vigorous in loamy soils. Another conspicuous plant is *Rudbeckia Newmanni*, growing 2 feet high, flowers deep gold with a black disc in the centre. It is a valuable plant in the border, and a grand summer plant may be found in *Rudbeckia purpurea*, a fine plant by no means common. Now look at something quite distinct in point of colour, I mean *Aconitum japonicum*, the flowers of which are an intense deep violet, habit dwarf and sturdy, and just now in its prime. It is quite alone among perennials and should not be lost sight of, for it is a valuable colour. Beyond this we have the gay flowers of the *Pentstemons*, very effective and varied. These are very attractive and useful as summer and autumn bedders, and their spikes of richly coloured flowers find but little to oppose them in the waning months of the year. There is, however, ample room for greater variety in this group, and it is in this respect they appear to have stood unaltered and unimproved for years.

Herbaceous *Phloxes* are nearly past, though one or two seem determined to make the display as lengthened as possible, *Mrs. Grundy*, lilac, suffused white, and *Queen of Lilacs*, pinkish lilac with salmon shade, being among the best remaining. Then to give some idea of the wide range in the flowering of *Lilium auratum* and its varieties, I may mention that plants are still producing good blooms, the earliest of which began in July. These all occupy the same bed, were planted at the same time, and yet there is a difference of three months in their time of flowering. We shall not have many more expand out of doors now, for the nights are too cold; but those who have spikes of well-formed buds may be glad to know that the buds will all expand if placed in water either in the greenhouse or the sitting-room, though for many people their perfume is much too powerful. Equally variable, too, is the colouring of the *L. auratum*, following which come *platyphyllum* and the varying forms of *Virginalis*. In some cases the latter are of the purest white and spotless, others have few spots, and are thus intermediate with *platyphyllum*.

Lastly, among the incessant flowerers are the *Violas*, in which *Archie Grant*, always to the fore, is conspicuous. I have not seen finer blossoms the whole year than I have gathered this week, with others of *Skylark* and its margin of deep violet; the colour of this is much deeper than in spring, and is certainly quite novel and pleasing. *Bullion* is improving. *Mrs. Gray*, *Queen of Lilacs*, and others still continue much the same. *Michaelmas Daisies* are very pleasing, and contribute shades of blue, violet, white, &c., and besides those mentioned are summer-flowering *Chrysanthemums* in variety, *Dahlias* of all sections, *Alströmeria aurea*, *Gladiolus* on the wane, also *Liliums* of the *speciosum* type, and when I conclude by saying that any and all of these may be found in any good collection of hardy plants in October, I think there is little room left for



questioning the lengthened period during which hardy perennials may be had in bloom, some of which I enclose that you may also get a glimpse of some at least of these worthy autumn-flowering plants, to which many more might easily be added.—J. H. E.  
 [A very fine assortment of flowers accompanied these notes.]

**NOTES ON CHRYSANTHEMUMS.  
 TOPPING PLANTS—EARLY BLOOMS.**

IN reference to Mr. Murphy's remarks (page 288) I agree with cutting down some of the tall growers, especially Madame C. Audiguier. We have plants 10 feet high and the flowers will not be open for a month or five weeks; on other plants that were topped good solid buds formed

at these (the Chilwell) nurseries will commence a week earlier than expected. I am told it will be opened to visitors the first week in November. Liberal prizes are also offered for Apples and Pears, which will be on view during the same period.—J. P.

**CHALLENGE PLATE AT HULL.**

WE have been favoured by the Secretary of the Hull Chrysanthemum Society with an illustration of the several pieces of plate that are to be competed for on November 16th. It is an imposing display, especially for a young Society, and indicates enterprise on the part of the Committee. As will be seen, the aggregate value of the articles is considerable, and that the Society has generous supporters. The references are given according to the arrangement of the plate, and the classes in the schedule indicated in each case.



**Class 24 and 25.**  
 Value £8 8s.  
 Presented by the Hull Amateur Floral and Horticultural Society.  
 Won in 1885 by E. Goddard, Esq.  
 Won in 1886 by A. W. Stanley, Esq.

**Class 1. Value £15.**  
 Presented by G. Bohn, Esq., Chairman of the Society, 1883-6.  
 Won in 1885 by Sir T. Edwardes-Mose, Bart.  
 Won in 1886 by C. W. Neuman, Esq.

**Class 30.**  
 Value £10 10s.  
 Given by the Society.  
 Won in 1886 by G. Lawson, Esq.

**Class 43.**  
 Given by Geo. Bohn, Esq., Chairman of the Society, 1883-6.  
 Won in 1886 by Miss Jameson.

**Class 13.**  
 Value £10 10s.  
 Presented by R. Falconer Jameson, Esq., Chairman of the Society, 1887.  
 Not yet competed for.

Fig. 40.—CHRYSANTHEMUM CHALLENGE CUPS.

on stems about 7 feet, and will be open in three weeks. Belle Paule is quite unsatisfactory; both on unchecked plants of 10 feet and topped plants the buds look puny, and do not plump up freely, although the plants are vigorous enough. It is quite the reverse with Fair Maid of Guernsey, for good buds will be open in three weeks on plants fully 10 feet high. The Queen family were mostly topped, the result being some good buds, but irregular; height averaging 4 feet. My experience of this family is, for large bloom they should be grown naturally, producing three flowers on an average. The kinds opening earlier here are Chinaman, La France, Mdle. Lacroix, Lady Selborne, Criterion, Jeanne d'Arc, fine; Alexander Dufour, Alfred Chantrier (new), Madame Freeman, M. Mousillae, Lakmé, Comte de Germiny, Fleur d'Hiver, François Deleaux, Henri Jacotot, Margot, Annie Clark, Reine des Blanches, Refulgence, and Thorpe Junior. The above are showing colour all from crown buds, and good blooms are expected. The exhibi-

**A LONG DROUGHT AND ITS EFFECTS.  
 DEEP v. SHALLOW LAND WORKING.**

PERMIT me to say that I think the curious article on page 300 last week might have been more appropriately headed "Iggulden's Mixture." As a concoction founded on facts and fancies, especially fancies, it must surely be unique. No one else, I suspect, could have prepared such a mixture for the gardening community to swallow. When reading it I was forcibly reminded of the observation of one of the best educated and most accomplished of British gardeners recently. It was in these words—"What is the matter with Iggulden? I am afraid he is overtaxing himself—writing so much in one place and another that he seems to be losing ballast." I was scarcely prepared to comply, but am now constrained to defer to the judgment of an unprejudiced overlooker of the literary arena.

Mr. Iggulden has no justification whatever for his cool assumption that I had charge of a garden "somewhere not far from Lincolnshire." I never had charge of any garden on the borders of that county. No Beetroot of my sowing and growing was ever wheeled out of the garden to the pigs in the manner so graphically described on the page quoted. A circumstance of the kind may have occurred somewhere, and no doubt did occur, or it would not have been recorded, but I have certainly never been snubbed for growing coarse vegetables, as the fanciful remarks imply.

And yet presenting that view of my capacity, your correspondent flatteringly refers to me as so "good a man." I am not aware he has ever seen my work "except on paper," and clearly that does not meet his approval. Where, then, does the "good" come in? I grow coarse vegetables and get snubbed; I communicate what my critic labours to prove erroneous, yet he, by some strange method of reasoning, applies to me the same mark of commendation as if he approved of everything I said and did. Ballast wanted.

As to the controversy of deep *versus* shallow land working, Mr. Iggulden is ready to fight the battle over again. That we can quite understand; but it is not necessary, and better for him not to fall foul of the first principles of husbandry. He knows best, no doubt, how to manage the land in his charge, or at least he is learning how to do so; but to denounce deep culture as a system is a waste of words. His first onslaught on it was practically unqualified, but he has since taken care to qualify almost every sentence. The last is in this wise, "Some gardens are benefited by intelligent deep cultivation, and there are plenty injured by a reckless adoption of the plan." The plan of what? Intelligent deep culture? No garden has ever been injured by that; and as for reckless intelligent culture there is no such combination, for if a practice is reckless it is not intelligent, and if intelligent it is not reckless. Much land in gardens and fields has been injured by deep working, as all intelligent gardeners and farmers know in these days. Burying a thick layer of sour subsoil on the better surface soil that is turned down in the process is not "culture;" it is spoliation. Culture represents improvement, and a cultivator is an improver. It is well to comprehend the significance of words before assailing a system. The so-called steam "cultivators" that were recklessly employed twenty or thirty years ago were entirely misnamed. They ought to have been called land ruiners. The best implements are very different now, for they stir well the surface and break up the subsoil, leaving the great bulk of it below. That represents culture by the crops following being better than those before them. I do not think there are any of these real "cultivators" in Mr. Iggulden's part; they have not reached there yet. The high culture of the north travels southwards slowly, consequently where the surface of land is merely turned over, the hard subsoil being left unmoved from generation to generation, farmers have to be content, or discontent, with less crops, landlords with less rent, and workmen with less wages than where the opposite system prevails.

Founding an argument in favour of shallow over deep working on a patch of ground of exceptional density—land that has not had its cultural resources developed—is a mistake. It is inherently faulty—a small dabbling with a great subject that can only do good in one way, and that is by making the weakness of the mere surface digging system more apparent. There are soils that will "hold" sufficient nutriment for the support of a fair annual crop in 9 inches or a foot from the surface, but even most of these are amenable to improvement by a more "intelligent" system, and in the overwhelming majority of cases the improvement from deeper working would be enormous. Science and practice prove this to demonstration. Most gardeners who have to be content with shallow culture regret the want of means to work the land deeper, but Mr. Iggulden does not appear to be one of them.

He says truly "heavy cold lands require sunshine and warmth." I suspect they cannot have warmth without sunshine, and goes on to add, "and they also require good surface culture." Why "also" when they cannot have the greatest warmth without it? They are warmed the quicker and better when the subsoil is broken and the water passes the more freely away. They are cold because wet, and that is the condition of the Marston garden. It is not until the stagnant water is out that the warm air can enter with its great fertilising power. The water must be dissipated before the heat of the earth is raised a degree. I told Mr. Iggulden a long time ago when trying to answer one of his characteristic essays, that if he could not drain his land in the ordinary way to throw it into ridges and crop them instead of sowing and planting on the level. He appeared to have found that Lettuces grew best on Celery ridges, and actually had the temerity to claim that as evidence against deep culture. They grew so well because of the deeper soil he provided them and warmer rooting medium. His own facts scatter his fanciful theories to the winds. If he can dig out a number of trenches and spread the soil on the ground between them without making that ground deeper he will be very near the solution of the old problem of putting a quart of beer into a pint pot. His experience of the best crops being on ridges proves with exactitude the benefit of a deepened and warmer soil. He lets us know that his past method of culture, which he advocated so strongly, was not the best, for he describes his ridge crops as "extraordinary." He is then learning still, and finding out in spite of himself the benefits of deep culture.

His successful experiment of placing Potatoes on the surface and covering them with soil equally proves the advantages of a deeper and warmer rooting medium for the plants. But what is an experiment with Mr. Iggulden is the regular practice in some other gardens where the land is of a cold heavy nature. I hope he will admit that the

difference between placing the sets on the surface and sinking them 3 inches below it is a gain in depth to that extent, and of the best and warmest soil. It is nothing less than extraordinary that anyone should so completely prove the fallacy of his own arguments, and apparently without knowing it.

My jaunty critic amuses himself at my expense because I gathered evidence in favour of deep culture from several of the best exhibitors of vegetables during the past hot season. These men he complacently pats on the back, and then denounces prize vegetables as coarse. I think he knows that in the best competition they are quite the reverse. They may be large, perhaps some of them too large for my fancy, but they are not coarse, or they would not win. And now let me give the retort courteous that he has invited. Judging by the reports of shows Mr. Iggulden never misses a prize when he can win it. He admits the hot summer has suited his garden exactly, yet I am not aware he has been strikingly successful in vegetable classes against the best growers. He used to be considered rather a formidable opponent, and I, with others, have been hoping to see him come to the front again, but so far in vain. The summer was right, but something else was wrong evidently; perhaps he had not time to muleh and give water, and attend to showing; still, I am glad to see he "pulled off" several prizes for fruit and cut flowers, and hereby has the congratulations of one whose harmless signature appears to "tickle him up" a little.—A THINKER.

[Another communication on this subject arrived too late for insertion this week.]

### GRAPE JUDGING.

AS one of those at the Crystal Palace fruit and flower Exhibition who heartily agreed that Mr. Ward was not justly treated by the Judges who were entrusted in making the awards in the Grape classes, I may be allowed to say a word on the subject, not that I am the least in favour of a matter of this kind being brought before the gardening community through the different periodicals, but quite the reverse. That errors do occur on the part of the judges is an established fact, and there is not the least doubt that exhibitors are very apt to overrate their own productions; but in Mr. Ward's case we have from the different reports which have appeared ample evidence that the Grapes in question were under-estimated. Further, I think it is scarcely consistent with reason that Mr. Ward, whose reputation as a fruit grower is well known to the public generally, or any other exhibitor of proved ability, would ever attempt to take inferior produce a distance of over a hundred miles in view of the chance of snapping up a prize, and especially to a first-rate exhibition, where the liberal prizes are likely to bring out a great competition. I am willing to admit that in Mr. Ward's collection there were a few weak points; but is not this the case in every collection of twenty dishes of fruit put up for exhibition, still not sufficient to condemn the lot, nor to convince those that saw them they were only deserving of a third prize? I had the privilege of seeing Mr. Ward's Grapes last year which easily secured for him the second prize in a good competition, and I saw them again this season, and at once took them to be far superior to those of last year. It is evident that such an enthusiastic gardener as Mr. Ward knew his bunches well before taking them to the Palace, and was not the least afraid of all comers, and undoubtedly he fully expected meeting several. In conclusion I need hardly say that to have twenty bunches of Grapes in ten distinct varieties fit for the exhibition table by the end of August or the beginning of September is a task probably only known to the grower.—VENN.

### PÆONY MOUTAN.

THE deciduous shrubby Pæony is becoming a great favourite. For many years two species have been cultivated, but of late the French and other hybrids have been introduced, and their extreme effectiveness as decorative plants has been recognised. There are two drawbacks to be found in Pæony culture, one is that the young shoots are liable to be injured by frost, the points of the growth also being generally killed back during winter. The other drawback is, that there will be very few shoots to become damaged unless some change is made in the old-fashioned mode of culture. Under ordinary shrubby cultivation the plants do not grow and seldom flower, but place them in rich well worked soil, and in a few years you have a bush which you occasionally step round in order to compare its progress, and the flowers a foot across may be counted by the dozen. After getting established the shoots must be occasionally thinned, and when the plants become too large they may be cut back with impunity. Both foliage and buds are of much value for filling large vases. They are indeed plants which everybody who has room should grow.—B.

### NOTES ON THE CULTIVATION OF ASPARAGUS.

I AM sorry I cannot answer "J. L. B.'s" queries on September 29th in the way I should like to do, as the Asparagus grown on the flat was only under my charge for the latter half of the season, and I do not know to what extent manure was given to the ground previously, although I believe it was the practice to give a good dressing of cow manure in the autumn, but not with salt in spring as advised. To some extent "J. L. B." may be right in his surmise as to its not being so liberally treated, and of course, through not salting, weeds were much more troublesome than they are now.

I should like to give my reasons more fully than in previous notes

for preferring the beds rather than the flat. First, I think they prevent the soil becoming close and hard, as it does by constant treading when cutting the heads and putting on manure, &c., as of course when the beds are made 3 feet 6 inches wide there is no need to tread on them, and the alleys being 6 inches below the surface of the beds, and dug in the autumn, act as drains for the surplus of the very heavy rains during the winter. It also has a much better appearance when planted in beds than on the flat. A small matter some may say; but for myself I consider the effect should be studied a little in such matters. It is also much easier to cover the manure with soil. I do not mean to say that Asparagus grown in very light soil, such as we have here, would never benefit by being grown on the flat. For instance, if we were likely to have many seasons like last, they would most likely benefit by it. At the same time, I think, that as a rule, before the dry season sets in, the grass is well advanced, thereby giving shade enough to prevent the roots suffering from the drought.

I am sorry I cannot quite agree with "J. L. B." in leaving the dressing of manure until the spring, as I should think that by doing it in the autumn it would help to keep the severe weather from the roots during the winter, thereby causing root-action to commence earlier in the spring than when it is delayed until then. Time, too, is a point to be considered, as it is far easier to spare it in the autumn than spring, and I question whether the rains after it is done in February would be sufficient to wash the manure down to the roots soon enough to assist the crowns in pushing up strong heads early in the season. This, I consider, is a thing to be aimed at, as if they are not a good size it often proves very unsatisfactory after our employers have been in the habit of having on their table some good French Asparagus. If the autumn dressing gives us an advantage here I consider that it fully makes up for loss of manure washed away through the winter. I also doubt whether manure is procurable decayed enough not to interfere with the young heads pushing through as regards heavy ground. For those who are placed at that disadvantage I would advise a trial of well forking the beds over as deep as they can without injury to the roots, and also leaving the surface as rough as possible in the autumn before covering with manure.

I, too, have seen beds treated in the way that "J. L. B." describes them to have been done in his young days, although I can hardly consider mine to have departed yet, and I quite agree with what he says, but I believe it is now only the practice of a few, and to those who still carry on the practice of deep beds. I feel sure that if they would give them a fair trial of the depth and culture, as recommended in Notes of September 15th, they will soon be rewarded with far superior Asparagus to what they have been having.

In concluding these notes, I beg to thank "J. L. B." for his kind and mild criticism and also for his advice, and I need hardly say that we are at one on this point—viz., that nothing succeeds like success. My reason for giving my first notes was that as I had succeeded so well I thought I would do all I could to assist others to attain that end; and I would also add that if others far better experienced than me would do the same—i.e., when they find plants under their charge doing extra well, give a good account of their mode of culture, &c., it would be advantageous to all.—P. T. D.

ORNAMENTAL TREES AND SHRUBS.

As the planting season is now here, advantage should be taken of it by garden owners to introduce new kinds of trees and shrubs by planting them in unoccupied positions, or rooting out worthless trees. We all know how greatly those old specimens of trees and shrubs to be found in many old gardens are admired, and how much the absence of them tells against the character of a new place, but with a proper selection and care in planting, the newest places may be made to assume a highly interesting appearance. New places, however, are not always planted with the best varieties. On the contrary, they are not unfrequently filled with the cheapest that can be bought, regardless of variety or future results. I have repeatedly heard garden owners say, "I had a great bargain in these trees and shrubs," but in nineteen cases out of the score there is no real truth in this. Planting of this kind may give temporary satisfaction, but when the trees grow and display their very common character, few will be satisfied with them, and it generally ends in many of them being rooted out. My advice, therefore, is to plant good varieties at first, and if expense is a consideration, I would rather be content with six good ones than twelve common and inferior.

WEIGELAS.—There are several varieties of these, but the best of them all is *W. rosea*. It is a native of China, and succeeds admirably in this country. It is quite hardy, and grows as a graceful spreading bush. The largest specimens we have are about 10 feet high and as much in diameter. It is deciduous, and comes into leaf in the early spring, and blossoms in April and May. Many of the branches are arching, and the Foxglove-like flowers are closely produced all along the branches. When in full flower it has a grand appearance. The plants bloom freely from the first, as I have seen small pieces only a few inches high clothed with flowers. It is therefore suitable for immediate effect, either isolated on the grass or mixed with other bushes. It grows freely in all sorts of soil, and I never knew it to fail either to grow or flower. Another favourite variety is *W. rosea variegata*. This has flowers like the preceding, but the leaves are more than half white, and it is one of the prettiest hardy bushes anyone could plant. Apart from the foliage its flowers are as showy as those of *rosea*, but it might also be used as a fine-foliage plant, as in this respect it rivals many of the Maples.

AZALEA MOLLIS.—These are comparatively new and not so widely known or extensively grown as they merit. As a rule they are only found in pots for greenhouse and conservatory decoration, and they are very useful for such purposes, but it cannot be too widely known that they are perfectly hardy and grow and bloom admirably in the open air. In this respect they are equally as good as the more common Ghent varieties, but they are far more massive and beautiful than these and vie with the best greenhouse varieties. They may be procured in variety, and should be planted in quantity, according to the extent of the garden. We have had some out for several years in different positions, and find them succeed well without peat or sand; or, in fact, just in ordinary soil, such as is to be found in all gardens. They cannot be planted in too many instances, and they may be transferred from the pots to the open soil as soon as the leaves drop in the autumn, or any time before they come on again.

THE LABURNUM.—This is known to everybody, but it is one of the finest flowering trees we possess, and it is not valued and planted half so much as it ought to be. Its pendulous racemes of bright flowers render it more pleasing and interesting than almost any other tree that could be named. They have a charming appearance in large or small gardens, and they are also admirably adapted for planting in front gardens in towns. They may be seen frequently, but the majority of the trees are getting up in years, and they must have been more extensively planted at one time than they are now. The golden flowering sort is the best of them all, and I would never plant a dozen deciduous ornamental trees without including this.

WELLINGTONIA GIGANTEA.—The Monkey Puzzle or Araucaria imbricata is a tree more frequently planted than the Wellingtonia, but it is by no means so valuable or pleasing, and I cannot understand why the Wellingtonia is not more planted in small gardens. The impression that it gains gigantic proportions and is altogether unsuitable for a small space may cause it to be shunned, but it need not, as although it gains a good size in this country it is by no means a clumsy tree. On the contrary, it is graceful in character and pretty in appearance. Six years ago there were two planted here by the Prince and Princess of Wales. At that time they were 18 inches high, but they are now seven feet, so that their average growth upwards is about 1 foot a year. They always keep a good form and are conical. Our largest tree is about 65 feet in height and 14 feet 10 inches round the stem at a distance of 3 feet 6 inches from the ground. This specimen, although large, is very compact, and would be by no means out of place in a much smaller garden than this. No special soil is needed for the Wellingtonia, and although they succeed best in partial shelter they also grow well in ordinary positions.—J. MUIR.

SHOW AND FANCY DAHLIAS AT THE NATIONAL DAHLIA SHOW.

THE Show of Dahlias at the Crystal Palace this year was the largest ever held there. The Fancies, no doubt owing to a new regulation governing the classes devoted to nurserymen, were rather less numerous than in 1886, but on the other hand there were nearly 270 more Show varieties staged than at any of the previous National Exhibitions.

The following short statement gives the number of flowers shown in each division during the last five years:—

1883	...	692 Shows and	269 Fancies.
1884	...	754	" " 425 "
1885	...	837	" " 355 "
1886	...	840	" " 387 "
1887	...	1106	" " 350 "
		4229	1786

The above figures are surely encouraging to the promoters of these National Dahlia Shows, as they clearly indicate a steadily increasing appreciation of this grand autumn flower. It will also be seen by the totals what a large number of blooms are now at our disposal for the purpose of this analysis.

Among the established Show varieties which were more frequently represented this year than usual may be mentioned James Cocker, Goldfinder, Prince of Denmark, James Stephen, John Standish, and Miss Cannell; and in the Fancy division Mrs. Saunders, Rev. J. B. M. Camm, Chorister, Professor Fawcett, and James O'Brien.

That exquisite variety, Mrs. Gladstone, again distances all her rivals in the Show section, being staged this year in no less than eighteen more stands than any other Dahlia, and in fifteen more stands than at the previous exhibition. At No. 22 we find Mrs. F. Foreman, and at No. 41 Mrs. G. R. Jefferd, both of which came out in the same year as the leading flower. Mrs. Langtry, although not quite so frequently exhibited as last year, still holds the first place (No. 11) among the 1885 flowers, but is closely followed by T. J. Saltmarsh at No. 13, and a few steps further down (at No. 22) by Mrs. Douglas, a refined and beautifully shaped scarlet variety. Mrs. W. Slack only made her first appearance in 1886, but never-



theless, for so new a comer, already occupies the very high position of No. 6 on the list, while Harry Keith stands No. 18, Thomas Hobbs No. 19, and R. T. Rawlings No. 47. Colonist, sent out only this spring, also takes a good place (No 22), considering how very recently it has been introduced; and at a respectful distance come two other novelties, Crimson King (No. 47), and Mrs. G. Rawlings (also No. 47).

The Fancies of recent introduction, headed by General Gordon (1885) at No. 5, occupy the following positions:—Duchess of Albany (1884) and Eric Fisher (1886) both at No. 15; Pelican (1886) No. 24, Lotty Eckford (1884) No. 25, Henry Eckford (1886) No. 26, and Edmund Boston (1887) No. 29.

It will thus be seen how rapidly the newer Dahlias are coming to the front. It is not, however, until we go back a few years that we begin to appreciate at anything like its true extent the surprising progress that has recently been made. Referring to my first analysis, which appeared in 1883, and comparing it with the present one, I find that no less than twenty Show varieties, which were not then generally grown, appear in this year's list among the

first fifty Dahlias named in it—viz., Mrs. Gladstone, Mrs. W. Slack, Mrs. Langtry, T. J. Saltmarsh, Harry Keith, Thomas Hobbs, Harrison Weir, Colonist, Imperial, Mrs. Douglas, Mrs. F. Foreman, James Stephen, Miss Cannell, Earl of Ravensworth, Hope, Mrs. G. R. Jefferd, Sunbeam, Crimson King, John Henshaw, and Mrs. G. Rawlings. In the list of Fancies the advance is not nearly so marked, for among the first twenty in the present analysis there are only three—General Gordon, Duchess of Albany, and Eric Fisher, which did not find places in that of 1883.

Of the twenty-three Dahlias just mentioned thirteen were raised by Keynes & Co., four by Rawlings Bros., and one each by Eckford, Fellowes, Harkness & Son, Hurst, and Turner.

In the tables the averages in the second column are calculated as follows:—For varieties distributed before 1883 the averages are for five years, for those of 1883 for four years, for those of 1884 for three years, for those of 1885 for two years, whereas in the case of the 1886 and 1887 flowers, the total number of times they were staged at this year's exhibition alone regulates their position in the analysis.

## SHOW DAHLIAS.

Position in present Analysis.	Average Number of Times Shown.	Number of Times Shown in 1887.	Name.	Date.	Raiser's Name.	Colour.
1	17.0	47	Mrs. Gladstone ... ..	1884	Hurst ... ..	Pale blush
2	22.2	24	Hon. Mrs. P. Wyldham ... ..	1881	Keynes & Co. ... ..	Pale yellow and rose
3	21.8	29	James Cocker ... ..	1871	Keynes ... ..	Purple
4	20.6	23	Henry Walton ... ..	1873	Keynes ... ..	Pale yellow and scarlet
5	19.2	27	Goldfinder... ..	1881	Fellowes ... ..	Yellow and red
6	17.0	17	Mrs. W. Slack ... ..	1886	Keynes & Co. ... ..	Blush white and purple
7	16.8	24	Prince of Denmark ... ..	1881	Fellowes ... ..	Dark maroon
7	16.8	20	William Rawlings ... ..	1881	Rawlings ... ..	Crimson purple
9	16.0	16	Mrs. Harris ... ..	1873	Harris ... ..	White and lilac
10	15.4	18	Joseph Ashby ... ..	1879	Turner ... ..	Shaded orange
11	15.0	14	Mrs. Langtry ... ..	1885	Keynes & Co. ... ..	Cream and crimson
12	14.4	13	Ethel Britton ... ..	1880	Keynes & Co. ... ..	White and purple.
13	14.0	16	James Vick ... ..	1881	Keynes & Co. ... ..	Purplish maroon
13	14.0	20	T. J. Saltmarsh ... ..	1885	Rawlings ... ..	Yellow and chestnut
15	13.8	13	Prince Bismarck ... ..	1879	Fellowes ... ..	Puce
16	13.4	13	Shirley Hibberd ... ..	1881	Rawlings ... ..	Dark crimson
17	13.2	14	Vice-President ... ..	1868	Keynes ... ..	Orange
18	13.0	13	Harry Keith ... ..	1886	Keynes & Co. ... ..	Rosy purple
19	12.0	15	Flag of Truce ... ..	1868	Wheeler... ..	White and lilac
19	12.0	12	Thomas Hobbs ... ..	1886	Keynes & Co. ... ..	Purplish rose
21	11.7	18	Harrison Weir ... ..	1883	Rawlings ... ..	Yellow
22	11.0	11	Colonist ... ..	1887	Keynes & Co. ... ..	Chocolate and fawn
22	11.0	12	Imperial ... ..	1883	Keynes & Co. ... ..	Purple, shaded lilac
22	11.0	11	Mrs. Douglas ... ..	1885	Rawlings ... ..	Scarlet
22	11.0	19	Mrs. F. Foreman... ..	1884	Keynes & Co. ... ..	Lilac
26	10.8	14	George Rawlings ... ..	1882	Rawlings ... ..	Dark maroon
27	10.7	9	Burgundy ... ..	1877	Turner ... ..	Dark puce.
28	10.4	14	John N. Keynes ... ..	1871	Keynes ... ..	Yellow
28	10.4	7	Mrs. Dodds ... ..	1881	Keynes & Co. ... ..	Blush and lilac
30	9.7	12	Clara ... ..	1879	Rawlings ... ..	Rosy peach
31	9.4	19	James Stephen ... ..	1882	Keynes & Co. ... ..	Orange scarlet
31	9.4	10	John W. Lord ... ..	1877	Keynes ... ..	Orange buff
33	9.2	19	Miss Cannell ... ..	1881	Eckford ... ..	Cream and crimson
34	9.0	21	John Standish ... ..	1872	Turner ... ..	Crimson
35	8.6	14	Constanoy... ..	1878	Harris ... ..	Yellow and lake
36	8.4	14	Earl of Ravensworth ... ..	1883	Harkness & Son ... ..	Lilac
36	8.4	9	Mr. Harris... ..	1881	Rawlings ... ..	Crimson scarlet
38	8.1	12	Hope ... ..	1883	Keynes & Co. ... ..	Light rosy lilac
39	8.1	11	Mrs. G. R. Jefferd ... ..	1884	Keynes & Co. ... ..	Deep yellow
40	8.0	14	Sunbeam ... ..	1881	Fellowes ... ..	Buff
41	7.8	6	Mrs. Shirley Hibberd ... ..	1877	Rawlings ... ..	Cream and pink
42	7.6	10	John Wyatt ... ..	1877	Keynes ... ..	Crimson scarlet.
43	7.4	8	James Service ... ..	1873	Keynes ... ..	Dark crimson
43	7.4	3	John Bennett ... ..	1875	Rawlings ... ..	Yellow and scarlet
43	7.4	4	Julia Wyatt ... ..	1869	Keynes ... ..	Creamy white
43	7.4	5	Royal Queen ... ..	1875	Eckford ... ..	Cream and crimson
47	7.0	7	Crimson King ... ..	1887	Keynes & Co. ... ..	Deep crimson scarlet
47	7.0	12	John Henshaw ... ..	1883	Rawlings ... ..	Ruby crimson
47	7.0	7	Mrs. G. Rawlings ... ..	1887	Rawlings ... ..	Blush and purple
47	7.0	7	Rev. J. Goodday ... ..	1879	Rawlings ... ..	Maroon, shaded purple
47	7.0	7	R. T. Rawlings ... ..	1886	Rawlings ... ..	Clear yellow
52	6.6	11	Champion Rollo ... ..	1881	Keynes & Co. ... ..	Orange
52	6.6	18	H. W. Ward ... ..	1881	Keynes & Co. ... ..	Yellow and crimson
52	6.6	5	Ovid ... ..	1874	Turner ... ..	Purple
55	6.4	4	Lord Chelmsford ... ..	1880	Keynes & Co. ... ..	Maroon
55	6.4	3	Thomas Goodwin ... ..	1873	Goodwin ... ..	Dark maroon
57	6.2	7	Alexander Cramond ... ..	1872	Keynes ... ..	Shaded maroon
57	6.2	6	Herbert Turner ... ..	1873	Turner ... ..	French white
59	6.0	8	Criterion ... ..	—	Edwards ... ..	Creamy rose

FANCY DAHLIAS.

Position in present Analysis.	Average Number of Times Shown.	Number of Times Shown in 1887.	Name.	Date.	Raiser's Name.	Colour.
1	180	22	Mrs. Saunders ... ..	1872	Turner ... ..	Yellow and white
2	174	14	Gaiety ... ..	1879	Keynes ... ..	Yellow, red, and white
3	146	21	R v. J. B. M. Camm ... ..	1873	Keynes ... ..	Yellow and red
4	134	13	Chorister ... ..	1881	Keynes & Co. ... ..	Fawn and crimson
5	110	4	Fanny Sturt ... ..	1868	Pope ... ..	Red and white
5	110	16	General Gordon ... ..	1885	Keynes & Co. ... ..	Yellow and scarlet
7	108	10	Flora Wyatt ... ..	1871	Keynes ... ..	Orange and red
7	108	16	Professor Fawcett ... ..	1881	Keynes & Co. ... ..	Lilac and brown
9	98	9	George Barnes ... ..	1878	Keynes ... ..	Lilac and crimson
9	98	10	John Forbes ... ..	1882	Keynes & Co. ... ..	Maroon
9	98	13	Peacock ... ..	1877	Turner ... ..	Maroon and white
12	96	11	Henry Glasscock ... ..	1875	Keynes ... ..	Buff and crimson
13	94	10	Mrs. N. Hall's ... ..	1881	Rawlings ... ..	Scarlet and white
14	84	6	Hugh Austin ... ..	1881	Keynes & Co. ... ..	Orange and red
15	80	11	Duchess of Albany ... ..	1884	Turrer ... ..	Orange and crimson
15	80	8	Eric Fisher ... ..	1886	Keynes & Co. ... ..	Buff and scarlet
15	80	4	Miss Lily Large ... ..	1876	Keynes ... ..	Yellow and crimson
18	78	4	Hercules ... ..	1877	Keynes ... ..	Yellow and crimson
18	78	3	Miss Browning ... ..	1880	Keynes ... ..	Yellow and white
20	74	6	Egyptian Prince ... ..	1873	Keynes ... ..	Orange and red
20	74	14	James O'Brien ... ..	1881	Keynes & Co. ... ..	Yellow and crimson
20	74	7	Rebecca ... ..	1883	Keynes & Co. ... ..	Lilac and crimson
23	70	4	John Lamont ... ..	1875	Keynes ... ..	Maroon and black
24	65	7	Pelican ... ..	1886	Keynes & Co. ... ..	White and purple
25	63	3	Lotty Eckford ... ..	1884	Eckford ... ..	White and purple
26	60	6	Henry Eckford ... ..	1886	Rawlings ... ..	Yellow and red
26	60	3	Oracle ... ..	1877	Fellowes ... ..	Yellow and crimson
28	54	4	Jessie McIntosh ... ..	1880	Keynes & Co. ... ..	Red and white
29	50	5	Edmund Boston ... ..	1887	Keynes & Co. ... ..	Orange and crimson

My thanks are due to Mr. T. W. Girdlestone for an excellent suggestion as to the numbering of the different varieties in the above lists. This suggestion I have now adopted. The alteration may be perhaps best explained by an illustration. As the tables have been hitherto numbered Mrs. Harris would appear as No. 8 in the list of Show Dahlias, but in the present analysis it is entered as No. 9. The reason for this is that Prince of Denmark and William Rawlings being equal and both No. 7, the next best Dahlia, Mrs. Harris, is therefore not entitled to the eighth, but to the ninth place. The relative values of the varieties may, however, be best ascertained by consulting the second column of the tables, which gives the average number of times each sort was shown at the last five National Dahlia exhibitions. I am also indebted to Mr. J. Burrell for kindly assisting me in taking down the names, and to Mr. W. H. Williams for supplying the dates of a few of the newer varieties which appear in this analysis for the first time.—E. M., *Berkhamsted.*

AROUND NEWCASTLE-ON-TYNE.

WYLAM.

A SHORT run by rail down the Tyne Valley, passing the birthplace of "Geordie" Stephenson *en route*, and the town of Wylam is reached around which we found several good gardens, the inspection of which kept us busily engaged until late in the evening. First upon the day's programme was a visit to Mr. George Cook of Stanley Vale, a few minutes' walk from the station, and notable for its bijou Alpine garden and the excellent taste displayed in the elegant villa and its surroundings. After a service of some years as gardener at Holeyn Hall, Mr. Cook was left a substantial annuity, and having acquired the site of the present house, he has since devoted his time to the formation of a garden unique in its way, and the cultivation of flowers, fruits, and vegetables for amusement. Few gardeners are fortunate enough to be able to spend the autumn of their lives in such an agreeable manner, and after working so long for others' pleasure, to devote their later years to the entertainment of themselves and their friends. Such, however, has been Mr. Cook's good fortune, and how fully he has appreciated his advantages is amply demonstrated in his garden. Adjoining the house is a small lean-to vinery, which is utilised for plants as well, and constitutes what is sometimes curiously termed "a mixed house." Black Hamburgh Grapes are chiefly grown, and alternate with them, trained up the front of the house, are Tea Roses, such as Marie Van Houtte and Niphotos, which yield abundance of their useful flowers. Then upon the back wall are Zonal Pelargoniums, with *Plumbago capensis* and *Lonicera sempervirens* that also flower freely in this position. Tomatoes in pots (the variety is Hackwood Park) are trained up at the side of the path, and most of the other portion of the house is occupied with

Adiantums and Begonias. All look in excellent health, and some idea can be formed of the interest derived from this vinery, which is conveniently reached from the house.

Outside is a small kitchen garden, and conspicuous amongst its occupants was a Cabbage of considerable fame in the north—*i.e.*, Cook's Improved Early, which is one of the most useful varieties grown. It is somewhat after the style of Ellam's Early, but I am under the impression it is rather more conical in form than that; it is, however, very compact, forms a solid heart, of good flavour, and comes into use very early. The great advantage of such Cabbages is their adaptability for small gardens, as they take up little space, and amateurs can fully appreciate the value of a variety that is so easily managed. This Cabbage has been much improved by Mr. G. Cook, but was originally raised by his uncle some years before, and is now as great a favourite in that district as Ellam's is elsewhere. Near the vegetable quarters are some prolific and healthy dwarf Apple trees, planted seven years ago, but root-pruned since then and now in excellent condition. Very satisfactory are Lord Suffield, Winter Hawthornden, and Cox's Orange Pippin, which give good and regular crops. Chrysanthemums, particularly the early varieties, are grown in quantity; Madame Desgrange, G. Wermig Mrs. Cullingford, and La Vierge are the favourites amongst the early varieties.

The garden slopes to the Stanley Burn, a small rocky stream, dividing Northumberland from Durham, and a pretty miniature landscape is afforded of well wooded hills beyond. To the right of the garden is a hillside and bank covered with Broom, which produces a beautiful effect when in flower, together with the Primroses, wild Hyacinths, and Ferns, which abound on the banks, constituting a charming piece of natural scenery. The higher portion of the garden is converted into a series of mounds, covered with hardy Heaths, and the general contour is exactly that of the Heather-clad hills which are so attractive in the north. There also a miniature alpine rockery has been formed upon a well considered system that gives it an appearance of much greater extent than it really possesses, a few large masses being employed in preference to a great number of small pieces, which give to some pretentious rockeries a close resemblance to a "heap" of stones. Numbers of Sedums and Sempervivums are planted in large patches, the pretty silvery white *Sempervivum Laggri* at once attracting notice. *Thymus lanuginosus* also runs about freely over the rocks and soil, forming a pretty carpet, while *Aubrietias* are largely used with capital results. Saxifragas are numerous, and the pretty *Acena Nova-Zealandica* covers square yards of the rockery with its numerous bright red needle-like flowers. The Edelweiss thrives as freely as it could in its native home, producing its curious woolly flower heads abundantly. Now that it has been found that this plant is readily raised from seed, and that plants in favourable situations will ripen its seed in this country, many will be induced to undertake its culture who have hitherto been deterred by the reputed difficulty of preserving it in health, and imported plants are seldom satisfactory. To afford some relief Alocs, Yuccas, and Funkias

are employed, with variegated Hollies, Thunias, and Retinosporas at the back. Narrow winding paths pass through and around the alpine garden, which is beautiful at any time, but must be especially so in the spring and early summer.

#### OAKWOOD.

Half an hour's walk or more across the rail and river, through the town of Wylam and Oakwood, the residence of Norman C. Cookson, Esq., is reached, where Orchids have been made a study and a specialty for some years past with a large share of success. Mr. Cookson is one of the few amateurs who have made any attempt at raising seedling Orchids on a large scale, but that he has given some considerable attention to the matter may be judged from the fact that there are now in the collection nearly 3000 seedlings in all stages, and these, moreover, the results of crosses innumerable between species and varieties in the same and different genera. Messrs. J. Veitch & Sons' wonderful stock of seedling Orchids will probably never be equalled, but as the production of an amateur in comparatively few years, Mr. Cookson's collection is remarkable. Of course, amongst so many they cannot all be prizes, but some good results have already been obtained in the *Calanthes*, and these first brought Mr. Cookson's Orchids into general notice. The seedling *Calanthes* in flower shown at South Kensington in 1885 were greatly admired, and that the Floral Committee should select two for certificates when good varieties of these plants are so numerous is an indication of their merit. *C. Alexanderi*, from a cross between *C. Veitchi* and *C. vestita rubro-oculata*, is remarkable for its intensely rich crimson colour in contrast with the two whitish lower sepals; *C. Cooksoni*, the result of a cross between *C. Veitchi* and *C. vestita luteo-oculata*, is one of the finest white-flowered forms in cultivation, the flowers of great size, pure white, with a yellow eye. Numbers of other crosses have been made with these plants, *C. Williamsi* being employed in several crosses with varieties of *C. vestita*, and there is quite a host of seedlings from which something good may be confidently expected.

The houses are conveniently built but not of any special character, the principal object being to obtain as much light as possible, with a uniform temperature and moisture according to the plants grown, a cooler house being reserved for *Odontoglossums*. But everywhere are seedling Orchids springing up—on the moss covering the roots, on the sides of the pots or baskets, and even on the material covering the stages. All are carefully watched until they can be placed with safety in the diminutive thimble pots plunged in larger pans or pots filled with moss, where they get through their early stages of growth. It would be impossible to refer to all the crosses made in this establishment, but a large book is kept in which careful record is kept of the time when the cross is made, the parents employed, and other particulars. It is, however, very difficult to preserve the identity of such minute plants as seedling Orchids, and, writing me in reference to this matter, Mr. Cookson observes, "I should be very glad to give you a list of the different hybrids I have, were I able to do so; but the fact is, though my gardener and I feel sure about the parentage of most, there are many I cannot be sure about until they are proved by flowering. Seed is often sown in certain pots, but is washed through on to the stages when watering, and grows on or under them. This year alone we have potted off many hundreds taken off or under the stages. Again, in dipping basket plants seed often floats off, and is afterwards carried on to plants where no seed has been sown, and there germinates. The great majority of plants, however, appear on the pots on which the seed is sown. A few years since we considered 5 per cent. of results good (*i.e.*, if we sowed 100 capsules, that five of them should produce plants). Last year and this we have only had 5 per cent. of non-successes. With regard to treatment, there is absolutely no difficulty or secret. Each capsule we obtain, both Murray and I examine with a microscope (generally using the  $\frac{1}{2}$  or  $\frac{1}{4}$  power) and we rarely find pods without some good seed. In the case of *Dendrobies* and *Cattleyas* the seed can be seen to commence to germinate very shortly after sowing, in some cases within a couple or three weeks. Many people are inclined to doubt this, but it is a fact. We have pricked off good strong hybrid *Dendrobies* within three months of sowing seed. The elements of success appear to me to be to keep the temperature and moisture right, and not to suffer dirt; more especially not a single thrip, to exist. One thrip is sufficient to kill a young plant (if allowed to remain on even for a few days) when in the young state. Another *sine qua non* is to water properly, or to put it more correctly, not to water improperly. I have seen seedlings suffer from too much water; but I do not remember having seen the reverse."

*Dendrobiums* have been made a special feature, and numbers of interesting seedlings are advancing rapidly. One that might be expected to produce something of an uncommon character is a cross between *D. Cooksonianum* or *Heathfieldianum*, and *D. nobile nobilius*, and this was in leaf seven weeks after the seed was sown. Other crosses in this genus have been effected as follows:—*Nobile album* × *japonicum*, *Ainsworthi* × *Linawianum*, *Falconeri* × *nobile*, *Ainsworthi* × *nobile*, *luteolum* × *nobile*, *Freemani* × *nobile*, and *nobile* × *Falconeri*. It will be seen from this that *D. nobile* is valued as a seed parent, and owing to its vigorous free-flowering habit it is just the type that requires to be increased for all useful purposes.

*Cypripediums* have had a large share of attention, and a great number of seedlings raised, probably more than of any other genus. Some young plants of an interesting and important cross are making good progress, and their flowering will be looked for eagerly. These were obtained from a cross between *C. Sanderianum* and *C. Veitchi* (*superbiens*), but Mr. Cookson informs me that the seed from which they

were raised was sent him by Captain Vipan, Stibbington Hall, Wansford, as at the time the seed parent was fertilised there was not a plant of *C. Sanderianum* in the Oakwood collection. A combination of the distinct characters in these two species should be remarkable. No less than seventy-nine crosses have been made between species in this genus, a few of the more notable being as follows:—*Parishi* × *Veitchi*, *Parishi* × *barbatum*, *Spicerianum* × *Haynaldianum*, *concolor* × *Boxalli*, *Veitchi* × *laevigatum*, *Lawrenciaum* × *venustum*, *Boxalli* × *laevigatum*, *Lawrenciaum* × *niveum*, and *Harrisianum* × *Stonei*. The *Cypripediums* are readily crossed, grow quickly, and the success or failure of the hybridist's skill can usually be ascertained in a few years, time, though we have seen hybrids that have not flowered until they were large plants eight or ten years old. Some of the finest results have, however, been secured in this genus, such for instance as the lovely and valuable *C. Morgania*. It should be added that a plant of *Cypripedium spectabile* growing outside at Oakwood had a seed pod swelling at the time of my visit which had been fertilised with pollinia from *C. niveum*. Whether it will result in a genuine hybrid is of course uncertain, but it would be a great step if a union could be effected between such very distinct groups.

*Cattleyas* require a considerable time to rear them from the seedling stage to flowering size, and much patience is requisite in those who wish to secure additions in this genus. Mr. Cookson has not done so much amongst these at present, but he has promising crosses between several of the *Cattleyas* and *Laelias*. The most noticeable of these are *C. Mendeli* × *Laelia purpurata*, *L. purpurata* × *C. Warneri*, *L. præstans* × *C. Dowiana*, ditto reversed, *C. Trianae* × *L. harpophylla*, *C. Lawrenceana* × *Mossia*, *L. majalis* × *C. Mossia*, and *C. Mossia* is also employed with several other *Cattleyas* and *Laelias*.

Amongst miscellaneous crosses in other genera may be noted one between *Phaius Walliehi* and *P. tuberosus*, which was made the 26th March, 1886, and the seed was sown in October or November of the same year. One young plant is now visible, and it may be imagined with what care it is watched. Crosses have been made between several of the *Odontoglossums*, and in some cases not only has good seed been secured, but plants have also been raised, only, however, to die long before flowers could be obtained—seldom; in fact, getting beyond the "infantile" stage. *Zygopetalum Mackayi* is regarded as a doubtful character by those experienced in these matters; and though crosses are apparently obtained between it and several other genera, the results are generally unsatisfactory, the seedlings, if any are produced, being simply forms of the *Zygopetalum*. Mr. Cookson has crossed it with different genera, notably with *Odontoglossum cordatum* and *Cœlogync cristata*, but what will be obtained is as yet uncertain. *Masdevallia bella* has also been crossed with *M. tovarensis*, and the seedlings are now ten months old.

There is a good general collection of Orchids, healthy plants of many fine varieties, in all the leading genera. In the cool house amongst the *Odontoglossums* is that grand variety of *O. crispum* named *Cooksonianum*, and in the *Cattleya* house there are also many handsome forms. The plants are well grown and evidently receive the best attention at the hands of the gardener, Mr. Murray, who takes as much interest in the experiments as his employer.—LEWIS, CASTLE.

#### NOTES ON EUCHARIS CULTURE.

It would be something like a national calamity in floriculture if anything serious were to happen with the successful cultivation of this plant. More especially in recent years losses, been met with by its cultivators, and various have the ideas been in regard to the cause and the cure. The *Eucharis mite* is said to be the cause. Various opinions by cultivators exist in respect to the insect, whether it is the cause, or the result of an unfavourable condition. There can be no doubt as to the result that may be brought about when the *Eucharis* gets into a declining condition. It takes time to cure it; though, like many other plants, if they get so low in condition, the question would deserve consideration if they would be worth "bothering" with for a cure—whether it would not "pay" best to start with a new and healthy stock.

My experience of *Eucharis* culture extends considerably over twenty years. For the last fifteen years or so I may say we have never been without some fine flowers in August until this year. Some of the specimens have been noted in the gardening press. Frequently we have had them with about fifty spikes, and up to over seventy spikes, all in flower at the same time, and your readers can imagine what a fine show they made. Some years ago I had a dread of this *Eucharis* disease or mite, as I knew it appeared with the most skilful cultivators, but luckily for a long time we succeeded in being able to say that we were free from it. But this year I have not been able to raise a flowering specimen of *Eucharis* in August, and if the question had been asked if we were free from this *Eucharis* mite, I could not freely say that we were. I account for them in the following way. I wanted to keep nearly a score of plants last winter for flowering at Christmas. The flower spikes just coming were quite visible over a month previously, and I wanted to keep them back for the purpose named. To effect this, they were kept so long in a cold and damp place, that when brought back to their old quarters in the stove the plants were much injured. Some of the edges of the leaves and stems were decaying, and on examination with a glass I found insects, which was the first time that I could say that I had seen a mite on any *Eucharis* under my own charge. All spring and summer I have felt rather vexed at the result. The summer, too, has been such a hot one that I applied no shade, as the stove is used for



Crotons and other plants that are rarely shaded. By reason of these two influences—injury in winter, and too much sun in summer—we failed this year to have a flowering pot of Eucharis in August. I am now, however, very glad to report that our Eucharis plants are looking most promising, as, though they were rather short of foliage until now, they at present show fine healthy young leafage, which is an almost certain indication of throwing off disease. Such a condition as this is rather cheering. I feel no doubt but the plants will be in their usual vigour again very soon.

Writing from memory, I think your frequent and ingenious correspondent, Mr. Bardney, once held the idea that he could produce the Eucharis disease and then cure it. I believe, too, personally he held the same views in conversation with myself. Latterly I think Mr. Bardney has modified his opinion, and my present impression is somewhat like his first view—that it may be produced; that circumstances will bring it about. As long as the plants are kept in good health, I think the Eucharis mite can be overcome; but the unnatural drying and storing in cool houses may soon ruin the plants. From my own experience now I do not dread the so-called mite, as I think I can say that we are now free from it, as our plants are throwing up such a profusion of young leaves with numerous white roots on the surface of many of the pots.

—R. M. A.

### METHODS OF PRUNING VINES.

"EXPERIENTIA DOCET" advocated a practice—to wit, long pruning, as a panacea for unsatisfactory cropping Vines, the roots of which were not under control. His favourite course seems to be in supplying information in respect of pruning Vines to the best bud terming it the "unorthodox system," yet when asked to point that bud out he declines, and refers me to "Work for the Week," September 1st, page 193. I fail, however, to discover any mention of long pruning for Vines that do not afford satisfactory crops of Grapes, but instead find a system in which modified extension is included—that is, pruning to a plump, sound, well matured bud on thoroughly ripened wood. "Experientia docet" makes the edifying statement that he did not write "Work for the Week;" all the same, the paragraph expresses very concisely his views on pruning Vines, which is the first acknowledgment of whence his indebtedness for ability to teach originates. That he has proved an apt scholar we are asked to believe in that he considers himself able, at least offers, to give "object lessons" for which he does not intend to charge until there is a better crop of Grapes. He now intimates he has done with the subject on paper "at present," therefore we hope he is going to practise, and further "experience" may be forthcoming. In the meanwhile we will regard him as like some of Tennyson's brooks this season—dried up; but "Work" gets fresher and fuller every week of information to cultivators seeking a supply of Grapes that will do them credit at the dessert as well as on the exhibition table.

Fruit trees bristle with buds this autumn, the hot summer has arrested wood and formed fruit—i.e., embryo. How was it there were such abundant crops of fruit in the year succeeding the last hot one? Is there not a prospect of its repetition to look forward to with hope and thankfulness?—G. ABBEY.

### CRYSTAL PALACE HARDY FRUIT SHOW.

OCTOBER 6TH, 7TH, AND 8TH.

The exhibition of Apples and Pears at Sydenham last week was a most satisfactory one, and very rarely has so extensive a display of fine samples been seen in London. Many expected that owing to the remarkably dry season the outdoor fruits would have been much under size, and it was also thought that there would have been fewer competitors. It was consequently an agreeable surprise to find these anticipations unfulfilled. The Show was held in the north nave, where fourteen stages, each 30 feet long by 9 wide, were arranged in two rows down the centre, besides a number of side and end tables devoted to vegetables and miscellaneous non-competing exhibits, very prominent amongst which was the extraordinary display of Tomatoes from Messrs. Sutton & Sons.

APPLES.—By far the most attractive portion of the Show, from a decorative point of view, was formed by the Apple classes, the colours being so varied and rich, and some of the fruits shown were of unusual size. The chief class was that for a collection of Apples, the number of dishes not specified, the prizes being £10, £6, £4, and £3. There were seven competitors, and the Judges had considerable difficulty in determining their relative position, as different numbers of varieties and fruits were staged, and this, taken in conjunction with differences in size and quality, necessitated a very careful comparison of the several collections. Ultimately Messrs. G. Bunyard & Co., Maidstone, were adjudged first honours for a beautiful display of 150 dishes, comprising a large number of handsome highly coloured fruits of all the leading varieties in cultivation. Grand fruits of Blenheim Pippin and Peasgood's Nonesuch were prominent amongst them; as were also the following varieties:—Annie Elizabeth, Red Astrachan, Frogmore Pippin, Lord Grosvenor, Malakovna, Melon Apple, Twenty Ounce, Wellington, Hoary Morning, Lord Suffield, Lady Henniker, Tower of Glamis, Red Hawthornden (very handsome), Washington (similarly fine), Pott's Seedling, Royal Jubilee (a yellow Apple of good size), Tyler's Kernel, Wealthy, Mabbott's Pearmain, Beauty of Kent, Stone's Apple, Cornish Aromatic, Ribston Pippin, Emperor Alexander, Manx Codlin, Lord Derby, Cox's Pomona, Scarlet Nonpareil, Warner's King, Stirling Castle, Cellini, Duchess's Favorite (brilliant colour), Downton Pippin, New Hawthornden, Gascoigne's Scarlet Seedling, The Queen, Colonel Vaughan, Queen Caroline, Golden Noble, Norfolk Beefing, Cox's Orange Pippin, Mère de Ménage, Tibbett's Pearmain, Crimson Queening, Alfriston, Small's Admirable, Ecklinville, and Belle Dubois. The Kentish

Apples were very strong all through the Show, but the credit of Hereford as an Apple county was also well maintained by Mr. John Watkins, Pomona Farm, Withington, Hereford, who was placed second in the large class. His collection comprised about the same number of dishes, the fruits even in size, remarkable for their high colour, and representing more local varieties than the first. Notable amongst the best sorts were Bull's Eye, Tom Putt, Holland Pippin, Calville Rouge, Striped Beefing, Nelson's Codlin, Warner's King, Green Costard, Stoke Edith Pippin, Hambledon Deux Ans, Peasgood's Nonesuch, Cox's Orange Pippin, Orange Goff, Lord Derby, Scarlet Crofter, Cox's Pomona, Crimson Costard (very handsome), Golden Noble, Mère de Ménage, Tyler's Kernel, Devonshire Quarrenden, Catshead, Blenheim Pippin, Duchess of Oldenburgh, Worcester Pearmain, Emperor Alexander, Gloria Mundi, Pott's Seedling, Ten Commandments, Hall Door, Tower of Glamis, and Lady Henniker. Mr. H. Borwick, Sidmouth, Devon, was third with good even fruits, and Mr. C. G. Sclater, Birchy Barton, Heavitree, was a close fourth.

A class for twenty-four dishes of kitchen and dessert Apples were also provided, in which the prizes of £3, £2, and £1 brought five competitors, Mr. J. McKenzie, Linton Gardens, Maidstone, winning first honours with some of the finest Apples in the Show. They were remarkable alike for their great size and high quality, the respective characters of the varieties being finely developed, and were all, we understand, from bush trees. The varieties were Loddington, Winter Hawthornden, Fearn's Pippin, Mère de Ménage, Ribston Pippin, Cox's Orange Pippin, American Mother, Cox's Pomona, Gloria Mundi, Lady Henniker, Ecklinville, Court of Wick, Warner's King, Gascoigne's Scarlet Seedling, Lord Suffield, King Pippin, Peasgood's Nonesuch, Frogmore Prolific, Summer Pippin, Worcester Pearmain, Emperor Alexander, and Lord Derby. Mr. Waterman, Preston Hall Gardens, Aylesford, being a good second, also with large fruits of Gloria Mundi, The Queen, Blenheim Pippin, Tower of Glamis, and Emperor Alexander. Mr. G. Ford, Leonardslee Gardens, Horscham, was placed third for clean even fruits of Lady Henniker, Peasgood's Nonesuch, Warner's King, and Blenheim Pippin amongst others of good quality. With twelve dishes of Apples, kitchen and dessert, the competition was exceedingly keen, no less than nine exhibitors entering. Mr. Fred. Smith, Loddington, Maidstone, secured the first place with handsome fruits of Tower of Glamis, Scarlet Admirable, Golden Noble, Gascoigne's Seedling, Ross Nonpareil, Cox's Orange Pippin, Ribston Pippin, Loddington, Warner's King, The Queen, Mabbott's Pearmain, and an unknown variety much like an enlarged form of the last-named variety. Mr. W. Jones, gardener to J. R. Brongham, Esq., Carshalton, won the second prize, his best fruits being Hollandbury, Emperor Alexander, American Mother, Gloria Mundi, and Ribston Pippin. The third place was taken by Mr. C. J. Goldsmith, gardener to Mrs. Howe, Kelsey Manor, Beckenham, who had some capital examples of Blenheim Pippin, Warner's King, Cellini, Ribston Pippin, Peasgood's Nonesuch, Emperor Alexander, Hawthornden, and King Pippin.

PEARS.—Similar classes were provided for Pears, and in the large class there were eight competitors showing eighty to 120 dishes, which occupied considerable space on the tables. Mr. F. Butler, gardener to A. J. Thomas, Esq., Orchard Lane, Sittingbourne, was easily first with ninety dishes of large handsome fruits, comprising remarkable examples of the following:—Beurré Clairgeau, Doyenné Bonsoch, Louise Bonne of Jersey (highly coloured), Pitmaston Duchess, Duchesse d'Angoulême, Durondeau, Beurré Diel, General Todleben, Triomphe de Vienne, Catillac, Beurré Rance, Marie Louise, Fondante d'Automne, Williams' Bon Chrétien, Beurré Hardy, Maréchal de Conr, Marie Louise d'Uccle, and the Black Worcester. Messrs. Rivers & Son, Sawbridgeworth, were second with about 120 dishes, including many fine fruits, but one or two of the earliest sorts were past their best, and the large size of Mr. Butler's Pears won him the first prize. Notable amongst the numerous varieties were Triomphe de Jodoigne, Catillac, Durondeau, General Todleben, Uvedale's St. Germain, Marie Louise d'Uccle, Duchesse d'Angoulême, Gansel's Bergamot (unusually fine), Glou Morceau, Pitmaston Duchess, Doyenné du Comice, Doyenné Boussoch, Magnate, Marie Benoist, Louise Bonne of Jersey, Fertility, Beurré Bosc, and Rivers' Princess. Messrs. G. Bunyard & Co., followed with eighty dishes of good fruits, some like Grosse Calebasse being of great size. Some of the best of the others were Beurré Diel, Williams' Bon Chrétien, Marie Louise, Louise Bonne of Jersey, Pitmaston Duchess, Souvenir du Congrès, Beurré Clairgeau, Triomphe de Vienne, Doyenné Boussoch, Marie Louise d'Uccle, Vicar of Winkfield, Durondeau, Brockworth Park, and Beurré de Capiaumont. Mr. C. J. Goldsmith was third with a large and good collection such as few private gardens could surpass. About seventy-two varieties were represented, and though some of the fruits were smaller than in the preceding numbers of fine fruits were observable of the best varieties.

The class for twelve dishes of Pears was extremely well filled, fourteen competitors staging, and the task of judging was a considerable one. Mr. C. J. Goldsmith won first honours with a most creditable collection of fine even fruits, clean, and well grown. The varieties were Uvedale's St. Germain, Doyenné Boussoch, Beurré Superfin, Doyenné du Comice, Beurré Bachelier, Pitmaston Duchess, Beurré Clairgeau, Williams' Bon Chrétien, Louise Bonne of Jersey, Durondeau, Chaumontel, and Beurré Diel. Mr. W. Chisholm, Oxon Houth Gardens, Tonbridge, followed, Mr. S. Ford taking the third place, both exhibiting well.

VEGETABLES.—Two classes were devoted to vegetables besides one for cottagers, and the numerous collections entered made an excellent display. In the large class for the best collection, number of dishes not stipulated, Mr. H. Waterman, Preston Hall Gardens, won the leading position for a tastefully arranged exhibit comprising over forty varieties of vegetables all in admirable condition. Mr. J. Neighbour, gardener to E. J. Wythes, Esq., Bickley, Kent, was second with a slightly smaller collection of good quality, and Mr. W. Must, Igham, Sevenoaks, was third with an exhibit of even merit. Ten competitors with twelve dishes of vegetables entered, and Mr. Neighbour secured the first place with fresh well-developed samples of Leicester Red Celery, Scarlet Runner Beans, Vicar of Laleham Potatoes, Rider's Tomatoes, Hollow Crown Parsnip, Veitch's Autumn Protecting Broccoli, Culverwell's Prolific Marrow Peas, Sutton's New Intermediate Carrots, White Globe Onions, Muskrooms, and Pragnell's Exhibition Beet. Mr. A. Waterman was a close second, Mr. C. J. Waite, Glenhurst Gardens, Esher, being third. Messrs. Wood & Son, Wood Green, also offered a

silver cup and money prizes for the best six fishes of veg tables, which brought five competitors. Mr. C. J. Waite was the most successful exhibitor, winning the handsome cup with Sutton's Perfection Tomatoes, Carter's Jubilee Runner Beans, Veitch's Autumn Giant Caul flowers, Prodigy Peas, Sutton's New Intermediate Carrots, and Deverill's Rousham Park Hero Onions, all in their best condition. Mr. T. A. Beckett, Cole Hatch Farm, Amersham, was a good second, and Mr. W. Must third.

**GOURDS AND PUMPKINS.**—The classes for these added some interest to the Show. Eleven specimens were shown in the class for the heaviest Pumpkin. The fruit from Mr. S. T. Wright, gardener to C. Lee Campbell, Esq., Glewston Court, Ross, Herefordshire, weighing 140 lbs., gaining the first prize, the others ranging from a Green Veg table Marrow weighing 22 lbs. to Pumpkins of 64, 72, and 94 lbs. Mr. C. Osman, South Metropolitan Schools, Sutton, had the best collection of Ornamental Gourds, including some very pretty varieties. Mr. T. Squire, 37, Westow Hill, Upper Norwood, having the best collection of Pumpkins and Gourds, mostly large fruits.

**MISCELLANEOUS EXHIBITS.**—Foremost amongst the non-competing exhibits were the Tomatoes from Messrs. Sutton & Sons, Reading, which occupied a side table 200 feet long, and constituted the most effective representative display that has been seen in London. The plants had all been grown out of doors, and were cut off near the ground and arranged on sloping frames just as they had grown, showing not only the particular character of each variety, but also their respective prolificness. The collection comprised thirty-five sorts, comprising Messrs. Sutton's own introductions, such as Earliest of All, Reading Perfection, Maincrop, Abundance, and Chiswick Red. The first-named sort, Earliest of All, was ready for use in August. It is a medium-sized Tomato of brilliant red colour and superior flavour, and very prolific. Two other excellent Tomatoes are Maincrop and Abundance, both of which are large croppers and excellent in quality; but Reading Perfection bears away the palm as regards quality, size, and productiveness. Some of the specimens of this variety exhibited were of immense size, the colour rich, and the fruit solid and of superb quality. The same firm also had a collection of Cockade Asters, a dwarf strain for bedding purposes.

Messrs. J. Veitch & Sons, Chelsea, had an extensive collection of Apples and Pears, notable for the clean even character of the fruits and the correctness of their names. Of Apples 130 dishes were staged, representing all the best varieties in cultivation and some of the recent varieties not yet generally known. Very handsome was Bismarck from maiden trees planted last year. The Sandringham and The Queen were also notable amongst the newer varieties. Of Pears there were eighty-five dishes similarly good and well grown. Messrs. T. Rivers & Son, Sawbridge-wor, contributed a collection of fruit trees in pots, together with Pears, Apples, Peaches, Plums, and Grapes. Of the last named Alicante and Gros Maroc were remarkably well coloured, and a tree in a pot of Bijou Apple, a medium-sized variety of bright red colour, was very attractive. Messrs. G. Bunyard & Co., Maidstone, had an interesting collection of Apples arranged on white paper in diamond-shaped beds, including some fine and bright samples. Messrs. G. & J. Lane, St. Mary Cray, also had a large collection of Apples.

Messrs. Cheal & Son, Crawley, contributed a varied group of Dahlias and hardy flowers, the former including Pompon and single varieties chiefly. Messrs. Paul & Son, Cheshunt, showed a similar group, but "Cactus" Dahlias and Michaelmas Daisies were the chief features.

### ABBERLEY HALL.

ABBERLEY HALL is not altogether a "new" place, but it has a comparatively new owner in Mr. J. J. Jones, who possesses not only wealth, but also the taste and discrimination capable of producing the best results. Mr. Jones' estate comprises many acres of field and wood. It is situated in a charming corner of Worcestershire adjoining the picturesque Severn valley, and the Hall stands on a noble eminence from which still more lofty summits may be discerned almost on every side. Abberley may be likened to a high mound in a capacious basin, for hills edge the horizon in a circle drawn with the eyesight round from left to right, while below stretch fertile valleys. From the front of the broad plateau on which the house stands the distant hills stand out sharply, while on the right is the almost precipitous Abberley Hill. Nature has done much for this fine Worcestershire residence, and Art, admirably directed, has stepped in to complete the work.

The Hall is approached from Stourport, distant about five miles, and the drive from this busy little town on a mellow summer evening is a pleasant experience. The road is a somewhat hilly one, and after a constant series of ups and downs, with every now and then a turn in the road or a break in the woodland opening up fresh views, the journey is finished by a short but steep ascent up the densely wooded hill to the gates and the garden.

Mr. Arthur Young is in charge at Abberley, and many practical articles in the Journal have given him the best introduction to its readers that could be had. The gardens are situated on the somewhat steep slope of the hill. They comprise several acres, a good portion having been brought under cultivation since Mr. Young's appointment some eighteen months ago. The kitchen garden is of considerable extent, and below it is a space of about an acre and a half planted with fruit trees this spring. The kitchen and fruit garden is hidden from the house by the trees and shrubs which clothe the bank above it. The latter was wild woodland till recently, now it has been cleared and planted with a rich collection of shrubs. Several specimens of *Lycostera formosa* and *Salisburia adiantifolia* have also been planted. This bank should form a very fine feature when the shrubs have developed. Ascending it and leaving the kitchen garden behind us we reach a delightful spot at the end of the house that can be best appreciated by non-visitors from a glance at the engraving (fig. 41.). Stone boulders have been skilfully arranged in a semblance of nature round a central pool, into which water trickles from interstices in the "rocks." A variety

of Water Lilies occupy it and lend attractiveness to the scene. Above this is a series of small caves, delightfully cool in the hot weather of early August. Between the trees shown in the photograph will be observed a handsome tower that has been erected by Mr. Jones at a cost of several thousands of pounds in memory of a deceased relative. The mansion is a fine substantial building, with a side wing, but this imparts a one-sided appearance to the structure that is not pleasing to the artistic eyes of its owner, and a second wing is about to be added. The place the latter must occupy is at present filled by the conservatory and fernery. The former is one of the most beautiful glass houses in the country. The floor is of marble, dark and white slabs alternating, and a magnificent marble fountain occupies the centre. The fernery adjoining is a delightful retreat. The Ferns are planted amongst boulders, and the sight and sound of trickling water amongst the latter render it still more enjoyable. A fine view of a large portion of Mr. Jones' estate can be had by stepping through the fernery to the broad terrace in front of the house. The first object to catch the eye is the tower before alluded to. It is a splendid building with 20 bells and unequalled chimers. Behind and beyond it the fine growth of trees—a great feature of Abberley—arrests attention. Many are of stately proportions, the dark green of the noble clumps being enlivened here and there by the red berries of the Mountain Ash. Just below the house on the right, and quite on the side of the hill, is a beautiful lake that has been constructed at enormous expense and labour under Mr. Jones' direction. Further afield may be observed the model farm now in course of construction, and which when completed will be one of the most perfect in the country. Picturesque lodges and labourers' cottages are dotted here and there. It is Mr. Jones' commendable wish to improve his estate in every possible way, and garden, wood, and farm all bear witness to his love of order and completeness.

Decorative plants and table decorations are largely in demand at Abberley. Houses are devoted almost exclusively to the culture of plants suitable for the purposes indicated. In one we find handsome little specimens of *Crotoneus aigburthiensis*, *interruptus aureus*—most useful for table decoration—*Queen Victoria*, *Warreni*, *Heathi elegans*, &c., *Dracenas rubra* and *elegans*—greenhouse kinds—*Linden*, *terminalis*, and the beautiful *Cooperi*. Then there are *Poinsettias*, *Caladiums*, such as the charming *candidum* and *Alfred Nain*, *Begonias*, and many other plants all in splendid condition. In one frame some fine *Cockscombs* were noted. The plants were raised from seed sown in March, and in August they were excellent plants for the decoration of the conservatory, having well-developed combs. In another there was an equally healthy collection of *Bouvardias*. Orchids have hitherto been mainly represented at Abberley by a collection of *Calanthes*, but Mr. Jones has just commenced preparations for the construction of fresh houses with a view to the cultivation of some of these beautiful plants.

In the existing glass structures the fine range of vineries is the chief feature. The range of vineries and Peach houses is 100 yards in length, and the houses have been constructed on the most approved principles. The Vines are something to see and discuss. The Black Hamburghs form a grand house. A good crop rather than exhibition bunches is aimed at, yet there are some fine clusters. There is a fine house of *Muscats*, too. Trained for several years on the short-spur system these Vines failed with exasperating persistency, but Mr. Young tried a fresh plan; he trained the Vines on the modified extension principle, and the result has been almost magical. They are carrying a fine crop, grand in bunch and berry. There are excellent crops, too, of *Black Alicante* and *Lady Downe's*. In one house the Vines were old and unsatisfactory when Mr. Young was appointed, so he removed them and planted young canes. These are not being fruited, and will be cut down until they form thoroughly strong stocks, while a temporary border has been made in front of them, and planted to produce fruit until the permanent occupants of the house are ready. Vines in pots, ripened bunches 4 lbs. in weight.

A word may be devoted to the Peaches and Nectarines. Of the former *Royal George* was bearing a fine crop, *Walburton Admirable* developing an equally meritorious one for later use. Another approved variety is *Violette Hâtive*. This is a very fine cropper. Amongst the Nectarines *Pineapple* and *Victoria* were perhaps the most esteemed for general good qualities. All the trees were in the best of condition. *Blenheim Orange* is the variety of Melon grown. It bears very freely, is of good quality, and is one of the hardiest of Melons; excellent, therefore, for gardeners and amateurs alike. Mr. Young never uses the syringe in the Melon house after the fruit has set. Tomatoes are not greatly in request, but a fair quantity is grown, the plants being cultivated in large pots in the Peach houses, and the growths trained to trellises. Amongst a good number of varieties tried, including several of recent introduction, the old *Hathaway's Excelsior* is much liked.

From fruit indoors we may pass to fruit out of doors. A large space in the kitchen garden is enclosed by a substantial wall. This is utilised to the fullest extent. The south aspect, which stretches for 100 yards, is clothed with as fine a row of Peaches and Nectarines as could be found. The trees are large and in splendid condition. The border was mulched to a distance of several feet from the wall, which is surmounted by a broad glass coping. To the mulching may no doubt be largely attributed the present excellent condition of the trees, for there had been little or no rain for many weeks, and here among the hills water had been very scarce. Amongst other good varieties of Peaches may be mentioned *Alexandra Noblesse*, *Barrington*, *Bellegarde*, *Noblesse*, *Royal George*, and *Sea Eagle* (an excellent late sort); and of Nectarines *Lord Napier*, *Pineapple*, and *Victoria*. On the west wall is a fine stretch of



young cordon Pears, there being about seventy trees 18 inches apart. These have been planted by Mr. Young and were mulched with decayed manure. Amongst the best varieties are Bergamotte Esperen, Beurré d'Amanlis, Beurré d'Aremberg, Beurré Superfin, Doyenné du Comice, Emile d'Heyst, Glou Morceau, Josephine de Malines, Louise Bonne of Jersey, Marie Benoist, and Pitmaston Duchess.

The open quarter of young Apple trees below the kitchen garden was earlier referred to. The space was formerly occupied by a few old trees of comparatively little use. These were promptly grubbed up, and

as Raspberries, Strawberries, and Gooseberries, are largely grown; the former have been excellent this year. Dr. Hogg and James Veitch are favourite varieties of Strawberries, the whole crop looking well. Mr. Young does not follow the old plan of applying the mulch just previous to fruiting time, but places it between the rows in spring. Of Gooseberries, Currants, &c., there are many hundreds of bushes.

The vegetable quarters bear the impress of one who has learned kitchen gardening under Mr. Lumsden, and would do credit to that great vegetable grower himself; they are extensive and well stocked.



Fig. 41.—ABBERLEY—ROCKWORK AND TOWER.

vigorous young trees of bush and pyramid planted in their place. It was late this spring when these were planted, but they were well mulched, and give every indication of forming fine fruitful trees. Amongst the varieties may be noted Potts' Seedling, a grand early Apple, Reclinville Seedling, Stirling Castle, Winter Hawthornden, Dumelow's Seedling, Cox's Orange Pippin, Greenup's Pippin, Tower of Glamis—a favourite variety, The Queen, Golden Noble, Warner's King, Schoolmaster, Alfriston, Mannington's Pearmain, Flanders Pippin, Domino, Peasrood's Nonesuch, Waltham Abbey Seedling, also much liked, Tom Putt, a capital amateur's Apple, and Maltster. Such other hardy fruits

Three of the best Peas were G. F. Wilson, Eckford's Progress, and Telephone. The first-named, as many know, is a fine variety of the Veitch's Perfection type; it would be very hard to find a better flavoured sort. Progress is new, and has created a most favourable impression; it is very prolific and sweet, growing about 5½ feet high. This season has been a severe test of new Peas, which have perhaps scarcely had a fair chance; still, there is the more credit due to such as have come well through the fiery ordeal. Telephone is now almost too well known to need comment; it is not likely to be discarded where tried. Autumn Cauliflowers are represented by Eclipse and Veitch's Autumn Giant;



the former is scarcely considered as good as the Giant, but is a little earlier, hence useful. There is a grand bed of Asparagus and another of Seakale, a young stock of the latter being raised annually. Of Rhubarb, too, there is a fine piece, planted in the spring. Johnston's St. Martin's is grown for early use, and the old Victoria for later pulling. Horseradish, which is generally allowed to look after itself in obscure corners, is cultivated in an open bed, so that when a few roots are wanted an hour has not to be spent on a busy day in hunting for them. Vegetable Marrows are grown quite in the open, and Pen-y-Byd occupies the post of honour; it is distinct and wonderfully prolific. The bed is prepared for the plants by excavating the soil to a depth of 3 feet and replacing a portion of it well enriched with manure. The Marrows are then planted and left to do the best they can; they have been good, even in this dry season, and they have not been supplied with a drop of water. Carrots, Onions, &c., are satisfactory crops. Of the latter, the Giant White Tripoli is much esteemed, and a variety named Golden Ball promises well. Potatoes are a good crop, Magnum Bonum being the most largely grown. Winter Greens were abundantly represented. Brussels Sprouts looked exceedingly well, and Kales are grown largely; of these the Scotch is found most valuable. It must be added in conclusion that the bothy is not a ramshackle shed, unfit for a human habitation, but a well-built house in the so-called Gothic style of architecture, with comfortable, well-lighted rooms that afford almost home comforts to Mr. Young's assistants. Possibly more may be heard about Abberley.—W. P. W.



**SNOW IN LONDON.**—The first snow of the season fell in London yesterday (Wednesday) morning, the roofs of buildings being covered from half an inch to an inch deep.

— **THE WINTER IN SCOTLAND.**—A correspondent writes: "In South Perthshire frequent frosts of from 2° to 4° were followed on the nights of the 8th and 9th inst. by 9° and 10°. Garden display is over. Potatoes are completely cut down. Bedding plants, Dahlias, and Gladioli are destroyed for the season. Snow has frequently fallen heavily on Ben Nevis, and on the 9th inst. the north slopes of Ben Lomond were white. The first snow in the low grounds fell on the morning of the 10th, when the frost gave way to heavy showers of sleet, and the lower hills had their first winter coat. The fall of the leaf is general and rapid, and already many trees are bare."

— A REVISED and cheaper edition of Mr. A. F. Barron's "VINES AND VINE CULTURE" has just been issued, and can scarcely fail to meet with ready acceptance by many cultivators who failed to obtain the original edition, and even those will find fresh and interesting matter in the new volume. We shall refer to it again.

— **CARTER'S KING OF THE RUSSETS POTATO.**—I see a reference to this new variety, page 292, last issue, and as it is likely to find its way into general cultivation, I should like to ask if other growers' experience differs from mine this season. It was planted in an experimental plot with thirty other varieties on the 16th February last, and lifted last week. The soil, a fairly rich loam, with south-western aspect, and rather high. The "sets" were cut to two eyes, and planted with only a limited manure dressing. The persistent dry and very warm weather checked somewhat the growth, but not to the same extent as other varieties. The growth was enormous, and the yield leaves little to be desired—thirty-five times the quantity planted—and this would be increased had the season been different. The tuber is very handsome, with shallow pink eyes, and the shape roundish ovate. It seems like a seedling from the old favourite "Pink Eye." It is wholly free from disease, and should be in request for exhibition purposes.—W. J. MURPHY, *Clonmel*.

— **MR. PIERCY** of Forest Hill sends us shoots of the early CHRYSANTHEMUMS LEON LASSALI and MRS. J. R. PITCHER to show the superiority of these plants for outdoor decoration when disbudding is not practised. One growth of the last-named variety was bearing twenty to twenty-five good blooms of a pleasing soft pink shade fading to white. The backs of the florets are of a deeper pink hue, hence a cluster of expanded blooms and buds have a charming effect.

— **METROPOLITAN PUBLIC GARDENS ASSOCIATION.**—The Earl of

Meath, the Chairman of this Association, has just appointed Mr. William Goldring, landscape gardener, Kew, to be Honorary Inspector of public gardens and open spaces in London. There are now a large number of these public gardens distributed about the metropolis, and their area, including those in course of construction, amounts to nearly seventy acres, constructed at a cost of over £15,000.

— **MANY** Chrysanthemum lovers and other horticulturists will learn with regret that MR. HARDING, gardener to J. D. Galpin, Esq. Bristol House, Putney Heath, died on Wednesday last, after being in delicate health for a considerable time. Mr. Harding won the Kingston challenge cup the first year it was offered—i.e., 1879, and after two years' unsuccessful attempts he won it a second time in 1882, when it passed into the possession of his employer. Mr. Harding was well known as a careful gardener, and as a quiet unobtrusive man gained many friends.

— **THE LEWISHAM AND DISTRICT FLORAL SOCIETY** will hold their Chrysanthemum Show in the Lewisham Town Hall on November 11th and 12th. The Hon. Sec. is Mr. H. Drake.

— **ONE** of the ancient habitats in Middlesex of the CHAMOMILE (ANTHEMIS NOBILIS) is being destroyed. The whole of Acton Green was carpeted with it; but now a thick layer of soil is being spread over the surface in order to raise the Green and render it drier, but this has destroyed the covering of Chamomile. This is one of the habitats given in Trimen and Dyer's *Flora of Middlesex*.

— **WE** have been furnished with another well-authenticated case of the UNION OF AN APPLE AND A PEAR TREE BY GRAFTING. The example which we reported a fortnight ago at page 271 of a Pear being grafted on an Apple, and both producing excellent fruit, is supported by a statement made by Mr. W. Kerl, of Angmering, who informs us that the account of his friend Mr. Stevens' success has induced him to make public an instance of an Apple being grafted on the Pear in his own garden. Mr. Kerl says, "I have a Jargonelle Pear trained against a wall which persisted in producing an abundance of wood but no fruit. I root-pruned and otherwise treated it, but got no fruit. About eight years ago I cut its head off and grafted what in Herts is called a Worstead Stocking Apple, an old favourite. After the first year it began to bear well, and now has a nice head over the wall. This year I gathered 110 fruit. I enclose a few small ones, the larger ones having been eaten. This year I grafted the ten horizontal branches with good Pears and Apples; ten of them have taken, and one has now five Apples one of which, the rosy one, I enclose."

— **MR. W. S. MANNING**, of the Vegetarian Society, 62, Ludgate Hill, sends the following APPEAL TO FRUIT GROWERS:—"We are holding weekly meetings in the largest halls around London during the next six months with a view to increase the demand for fruit as foods. To enable the public to see the need of thinking out and testing the question of a fruit and grain diet, we distribute at all these meetings, samples of wholemeal bread of attractive make and rolls, also Apples and Pears, with a view to increase the popular interest in home-grown hardy fruits of the best dessert qualities. We therefore venture to invite your readers to inform us if they can send any samples of their surplus fruit either for distribution or for exhibition. The meetings held in North London during the past month have been on each occasion thronged by intelligent audiences, and the greatest interest has been shown in the question. If ever the people can be got to realise all the benefits to be enjoyed from really good fruit they will study to know our own Apples and Pears, and will be eager to become connoisseurs of the best sorts, and this must tend very largely to increase the demand for such fruits. In fact the consumption might be easily doubled of all our home-grown fruits every year for some time to come if the needful supply could be only put on the market of the most attractive and popular sorts." Farther particulars can be had from the address given above.

— **VIOLET CULTURE.**—Mr. J. Roberts writes:—"Your favourable comments upon the Violet blooms I sent you, induce me to write a word as to their cultivation as practised here. We only grow three varieties, Marie Louise, Comte de Brazzi, and Odoratissima (paragons in Violets). These are grown in immense quantities to meet our demands, the latter being grown outdoors mainly for their foliage for bunching, leaves being scant on really good flowering plants of the other hues."

Our soil—so called for compliment—is really nothing more than a thin layer of shaly stones. The greater part of our stock are cuttings struck annually outdoors, in the autumn, and left in the cutting beds until late in the spring, when they are transplanted under fruit trees for the summer and following winter, receiving no attention further than weeding, until lifted in spring, divided if necessary, and transplanted 9 inches apart in the open quarters of the kitchen gardens, mostly following Cauliflowers or such crops. They are treated liberally during summer with 'Beeson's,' and in autumn lifted with good balls of earth and roots, and placed in sunken pits for winter blooming, covering with lights merely to throw off heavy rains, &c., and for protection against severe frosts. From various causes we have recourse at times, from scarcity of stock of struck cuttings, to dividing the old plants, selecting the strongest healthiest crowns, giving them similar treatment in every way to the others during their last preparatory season, as these will in all cases be good flowering plants at the end of their first summer. Treated thus we are seldom without Violet blooms during any part of the year. As to the mode of packing you so approve of, I may say that we annually send hundreds of boxes similarly packed, and have not had a single complaint of their having arrived at their destination other than in the most satisfactory condition."

**SOUTH AMERICAN PLANTS.**—In 1884 Mr. John Ball, F.R.S., published a paper in the Journal of the Linnean Society (vol. xviii. pages 203-240) giving the first comprehensive account of the flora of North Patagonia. This was based on a collection obtained from him during his travels in South America from M. Georges Claraz, a Swiss gentleman who had passed several years chiefly at Bahia Blanca. Mr. J. L. Williams-Andrews has now sent to Kew a beautifully preserved collection made by him in the same region during the years 1881-85. The excellence of the specimens is the more remarkable as the majority of them have travelled more than 600 miles on horseback. Mr. Williams-Andrews writes to Kew:—"The Indians are certainly a very fast-decreasing race, and at the present day cannot exceed 2000 in number. The combs, or rather brushes, mentioned by Mr. Ball in his paper, page 225, are formed of a species of very tough grass, not of roots. The use of vegetable dyes is also rapidly dying out amongst them, though they still make a considerable quantity of textile fabrics, of which I have numerous examples; the same is to be said of their silver ornaments." Vice-Consul Goodhall, of Bahia Blanca, has taken much trouble to obtain information about the plants used by the Indians for dyeing purposes. He has unfortunately failed in obtaining trustworthy specimens, as "the Indians are most jealous about affording any information on the subject." Mr. Ronald Bridgett, Consul at Buenos Ayres, has sent to Kew some articles dyed by the Indians, in which the greens and yellows are native dyes made from roots and plants. These have been sent to the Chemistry and Dyeing Department of the Bradford Technical College.—(*Nature*.)

— AT the ordinary weekly meeting of the WAKEFIELD PAXTON SOCIETY, held at the Saw Hotel, the President (Ald. W. H. Lee, J.P.) presided, and Mr. Hudson occupied the vice-chair. There was a good attendance of the members. Mr. Thomas Tate, F.G.S., teacher of Botany at the Mechanics' Institute, delivered an able lecture on "Flowering and Non-Flowering Plants Compared," in which he explained that the distinction—based upon the reproductive structures and functions—which has seemed to separate these two groups of plants, have been dispelled by the recent investigations of English and German botanists. The lecturer illustrated his subject by diagrams and drawings on the black board. He was very attentively listened to, and at the close a hearty vote of thanks was passed to him, on the motion of Mr. W. L. Skinner, seconded by Mr. T. Senior, for his admirable lecture.

— THE "American Gardener's Monthly" generally contains some useful practical hints, and from the October issue we extract the following suggestive paragraphs:—"One of the cheapest and best modes of destroying insects on pot plants is to invert the pot and dip the plant for a few seconds in water warmed to 130°. It is the best plan for destroying insects, unless we have to deal with plants on a very large scale. We notice that the 'Garten Zeitung,' in referring to the plan says that the Azalea will stand 133° without injury. We usually heat the water pretty well and pour in cold till 130° is reached."

— OIL AND MILDEW.—"Those who are likely to be troubled with mildew would do well to remember Mr. Veitch's remedy of oil on hot-

water pipes is good against its development. Since Mr. Veitch gave that remedy to the public we find by research in chemical botany that oily vapour has long been known as inimical to the growth of the lower forms of fungi, and that Mr. Veitch's successful practice is in full accord with the teachings of this branch of science.

— GLAZING WITHOUT PUTTY.—"No one uses putty over glass in glazing in America any more, but it is still used for bedding in the glass, but even this is unsatisfactory. It will often loosen and come out. Mr. Henderson recommends that thick white lead and oil be run along, and on this sprinkle dry light sand before laying on the glass. It is a much better plan than the old putty bedding."

— HORSETAILS FOR THE FLORISTS.—"Green ferny foliage that will not rapidly wilt as Fern fronds will has caused a number of plants of the Asparagus family to become almost indispensable to the florist. An addition to this class of popular florists' stuff has been found in Europe in the different species of Equisetum or Horsetails. These have firm fronds that do not wilt easily."

— To the diminutive PRIMULA SAPPHIRINA and bell-shaped P. REIDI a plate is devoted in the October issue of the "Botanical Magazine." They are both Himalayan species, and the first named was discovered by Sir Joseph Hooker in the Sikkim Himalaya at elevations of 13,000 to 15,000 feet, "Where it starred the otherwise bare soil and rocks, soon after the melting of the snow, with its gem-like flowers." The plants vary from 1½ to 2½ inches high from the base of stem to the top of the flower head. P. Reidi we have already figured and described; it was found by Mr. Duthie in the Western Himalaya at elevations of 12,000 to 13,000 feet.

### HOLLYHOCKS.

I HAVE to thank Mr. Webb most heartily for his courteous reply through the Journal for his list of leading varieties. From what I have heard of some he enumerates I think we are on the right track. Mr. Boston in his able remarks, page 267, certainly takes the little conceit we have out of us in Hollyhock growing, but I would remind Mr. Boston "not to despise the day of small things." Many of our finest novelties have been raised in the cottage garden of some of these "minor lights," and if it had not been for the little shoemaker (Mr. Chas. Barron), where would he have got many of the gems he so proudly speaks of? We have as yet nothing to boast of in Hollyhock growing, and are at present content with blooms half the size of Mr. Boston's 9-inch "corner peg." Our object is to encourage growers, and in raising new varieties we may yet be honoured with another Glory of Waltham, a Lizzie, or even a Lord Loughborough. Let us not overlook Mr. Boston's hint as to the disease. There is not the least doubt that plants which have been heavily fed for exhibition are the first to succumb. The constitution seems to be forced out of them, they can neither stand frost nor damp. I think artificial manure ought to be used with great caution, for I have often noticed where plants have been artificially fed the ground is infested and putrefied with vermin of every description.

Mr. Dean has no doubt reason to be proud of the interesting remarks he has already drawn from your readers, and as he says, with the winter before us, there there is ample time to discuss the Hollyhock disease and its remedies.—G. STEEL.

### NATIONAL CHRYSANTHEMUM SOCIETY.

FLORAL COMMITTEE, OCTOBER 12TH.

The second meeting of the season was held on Wednesday afternoon in St. Stephen's Hall, Westminster, but it was rather too early for many exhibitors, and there will no doubt be a better attendance at the next meeting on October 26th.

Present:—Mr. E. Sanderson in the chair, and Messrs. R. Ballantine, C. Gibson, R. Owen, J. Mardlin, H. Cannell, Lewis Castle, G. Gordon, R. Dean, J. P. Kendall, C. Swift, and G. Langdon.

This season silver and bronze medals are offered for the best stands of new varieties not included in English nurserymen's catalogues before November, 1886, and two collections were entered for these awards. Respecting the first there was little difficulty, but with regard to the other it was decided one of the varieties had been listed before the time stipulated, and it was therefore reluctantly disqualified. The silver medal was awarded to Mr. G. Stevens, Putney, for a stand of twelve new Chrysanthemums, comprising Feu de Bengale, William Cobbett, C. Wagstaff, a large white Japanese, Ormonde, Macbeth, Rose Stevens, James Stevens, O. J. Quintus, Elsie (reflexed), Romeo, Martinus (reflexed), and M. Canet (reflexed). The blooms were of good size and fresh. A stand of a dozen fine blooms of Middle Lacroix was sent by the same exhibitor. The new varieties are described in the report of the South Kensington meeting. A vote of thanks was accorded to Mr. R. Owen, Maidenhead, for a stand of twelve varieties, mostly new, but a bloom of William Holmes excluded it from the award of a bronze medal. Romeo, Lincoln's Inn, and William Cobbett were the most notable blooms. Mr. Owen also sent a box of fine Tuberos Begonia blooms. Mr. William Holmes, Hackney, exhibited a stand of Japanese blooms similar to those at South Kensington on the previous day, O. J. Quintus being very notable for its soft mauve colour (vote of thanks). Messrs. H.



Cannell & Sons, Swanley, had a basket of plants of the neat double white Begonia Octavia with blooms of double and single Tuberos Begonia.

A first-class certificate was awarded to Mr. G. Stevens for the Japanese William Cobbett, the same variety that was certificated the previous day at South Kensington, and is described on page 325 this week.

The majority of the Chrysanthemum growers present state that their plants are later than usual this year, and it is expected that some of the public displays like that at Finsbury Park will be fully a week later than last year. The prospect of good blooms and plenty of them is encouraging, and with favourable weather satisfactory shows will no doubt attract numbers of visitors.

### VINES AND INSECTS.

THERE are still those who cling with considerable tenacity to the notion that it is next to an impossibility to grow Vines under glass without their being subjected to an attack of red spider in some stage of their growth. Such conclusions may have a very consoling effect on the minds of those who have their old friend year after year to devour the foliage of their Vines and cripple their energies long before the work of accumulation and maturation has been completed. It would indeed be a comfort to us if we could but realise from the following year's results that no harm was done by an attack of this troublesome little pest.

To look upon red spider as practically harmless if the Grapes can be finished, is fostering in the minds of many young gardeners and amateurs a sort of indifference and carelessness about a matter that is of the utmost importance if Vines are to be retained in health and produce large crops of excellent fruit annually. I have seen Vines literally devoured, and considered by those in charge as a "slight attack;" in fact the matter treated with indifference by not attempting, after the fruit had been cleared away, to eradicate it. The destruction of the foliage early in the season, or months before it should assume an autumn appearance, too frequently results in badly coloured puny fruit that shanks and shrivels the following season instead of attaining a high state of perfection. It may be questioned whether a severe attack of red spider will result in shanking the following season. It would be difficult to disprove the case, much more so than to prove many of the notions to which shanking is attributed. To allow the foliage to be devoured and rendered useless, just at the time when there is most need for it to assist the Vine to bear the burden of the crop and finish in a natural manner its season's work, is equally as bad as tearing the foliage from the Vines in a green state as soon as the fruit is ripe. What would be thought of the individual who did this? The wonder is that there is fruit of any description the following season, for the fact cannot be overlooked that directly the foliage fails the whole work of the Vine is brought to a standstill. Only half the season's work has been done when the fruit is ripe, for the Vine has to perfect its wood and buds for the following season, and store food from which the young growths can draw supplies before the roots are called into requisition.

It may be thought that I am presenting an overdrawn picture of the evils that result from red spider attacks, but such is not the case, for I have seen Vines, and Peaches too, this season, that were as brown as if they had been roasted in an oven. If the destruction of the leaves by spider results in such baneful effects, slight attacks also do injury to some extent. It may not be sufficient to be perceptible the following season, nevertheless it is hard to say what superior results might be attained if no injury to the foliage had occurred. Many houses are cleared of Grapes and the foliage still fresh upon them; in fact as the fruit is cut see that no insects exist upon the foliage. If ever so few they should be destroyed at once, although the season is advancing and they would not spread to any serious extent now that the sun has lost its power and the houses will be kept cool. It is important that they be destroyed, not only for the preservation of the foliage this year, but as a provision against an attack another season. It is not sufficient to trust to a thorough washing or painting of the house and the removal of the surface soil of the border. There are plenty of crevices in which insects can establish themselves ready to spring into life and attack the Vines at the first favourable opportunity that presents itself in spring or early summer. A few good syringings might displace them, and prove ample for the preservation of the foliage until the end of the season. But this would not insure thorough destruction, therefore more stringent measures should be adopted to do so.

Various courses can be taken, and the Vines syringed thoroughly with any insecticide that will destroy spider. Many have compositions which they prefer and have proved to be effectual in destroying it, but there may be others who scarcely know how to proceed, or whether they are using a too strong or too weak solution. The one I prefer for red spider consists of 3 ozs. of softsoap dissolved in four gallons of water, with two good handfuls of sulphur stirred into it. This should be mixed first with a little water, and then stirred into each four gallon bucket as the solution is applied. If placed into the bucket or other vessel used it floats, and takes some

time before it can be properly mixed ready for use. This solution may be freely applied, for it will do no harm. This may be allowed to remain on three or four days, or even a week. The length of time depends upon the weather, whether it is bright or the reverse. It does its work quickly and effectually during bright fine weather, and is considerably longer and less effectual during dull sunless weather. It may here be mentioned that if red spider attacks the foliage during the growing season this is our sole remedy. The under side of the leaves are sponged when it is first seen; not only the leaves attacked, but for some considerable distance round. It may take a little longer than sulphuring the pipes, which is practically useless unless they are rendered hot, for it will not destroy the red spider, and if the fumes are strong enough to do this they are certain to prove injurious to the Vines. The plan advised I have never known to fail. After the Vines have been syringed and the sulphur has been allowed to remain until the spider is destroyed, then thoroughly wash the Vines with clean water.

Next to this plan a solution of petroleum and water is preferred. Three ounces of the former to four gallons of the latter will prove effectual. The oil must be well broken up by returning one syringeful in the bucket with force, and then distribute the next quickly upon the Vines. The action of the sun and oil is apt to turn the foliage rather yellow, but this can be prevented by a light shade over the roof for a day or two until the oil has evaporated. As soon as the foliage is dry the shading may with safety be removed. Fir tree oil, lemon oil, Fowler's insecticide, and Gishurst compound, mixed as recommended by each vendor, will also destroy red spider without injury to Vines.

Thrips are no less harmful on Vines than red spider if they are allowed to commit their ravages unmolested. It is indeed questionable if they would not do greater harm than the red spider in less time, for they are not content with devouring the foliage, but prey upon the wood as well as the fruit. They are, however, much less to be feared, for their ravages can be checked by fumigating the house with tobacco smoke, and two or three applications at intervals of a few days will destroy them. Perhaps thrips do most injury if they make an attack about the time the fruit is approaching maturity or is hanging ripe on the Vines. This arises principally from a common idea that the smoke will interfere with the flavour of the fruit, and in consequence they are left until the fruit has been cut. Smoking when the fruit is ripe, or approaching that stage, will not injure it in the least. All that is needed is to cut the supply for a few days before the house is fumigated, for the fruit will smell of the smoke for a few days only.

It has been said that mealy bug amongst Vines is "worse than phyloxera," and that it is "impossible" to eradicate it. I would rather have the former than the latter to deal with, and differ widely from those who think its destruction an impossibility. How to accomplish this desirable end will take up too much space on this occasion, and must therefore form the subject of another communication.—WM. BARDNEY.

### ABERAMAN HOUSE.

ABERAMAN HOUSE, the South Wales residence of Sir George Elliott, Bart., M.P., is situated midway between Aberdare and Mountain Ash. The house is a modern structure, and attached to it is a fine balcony supported by fifteen columns, which gives it a grand architectural appearance. Adjoining the mansion is a span-roof conservatory, which at the time of my visit was occupied with Fuchsias and collection of Palms and other choice plants, some of the Palms being grand specimens, particularly Phoenix dactylifera, Phoenix reclinata, and Scaforthia elegans 10 feet high, with fine foliage down to the base. This house also contains a fine specimen of Latania borbonica, about 12 feet in diameter. The lawn in front of the house was looking very effective with bedding plants intermixed with Conifers, Yuccas, &c. The pleasure grounds in general with the huge clumps of Rhododendrons, Ghent Azaleas, choice Conifers, herbaceous borders, &c., are all one could wish to see in a nobleman's establishment.

Aberaman has been noted for many years for the cultivation of the Pine Apple, and at the time of my visit I came to the conclusion that they are still well grown. I noticed some fine Queens, which when ripe would weigh over 5 lbs., and Smooth Cayenne would no doubt reach 8 lbs.; they are all fruited in 12-inch pots. The Vines are also looking well, bearing large bunches of the varieties Black Hamburgh, Black Prince, Alicante, Golden Champion, Mrs. Pince, Venn's Muscat, Trebbiano, Gros Guillaume, West's St. Peter's, Muscat Hamburgh, Bowood Muscat, Lady Downe's, and Muscat of Alexandria. The whole of them are in good condition, carrying a fine crop of Grapes, the bunches weighing from 2 lbs. up to 7 and 8 lbs. each. The black Grapes are superb in colour, berries, bunch and general finish, the Black Hamburgh having been awarded the first prize for three years in succession at the Aberdare Horticultural Show in strong competition; this is sufficient proof that the Grapes are well grown in these vineries. The stove plants are in good condition, amongst them being some fine specimens. Eucharises are well grown, the plants measuring 5 feet in diameter,



with healthy foliage, and numerous handsome spikes of bloom. Strawberries for forcing look well and promise to produce a good crop of fruit. The kitchen garden being well stocked with vegetables, very creditable for this climate; in fact, the whole garden is kept in excellent order by the gardener, Mr. Mitchell.—VISITOR.

### VIOLAS.

MR. STEEL'S interesting communication on page 275 has prompted me to offer the following remarks, though I trust your correspondent may alter his mind as regards his closing words, and let us know what he has to say of Violas generally, even if his questions are not answered to his liking. Why should not Mr. Steel as a grower of these flowers contribute his quota towards solving the problem? From a botanical standpoint the characteristics of a Viola are as follows:—"Calyx with unequal sepals, all drawn out at the base more or less into ear-like appendages, lower petals drawn out at the base into a hollow spur. Stamens approximate, the two anterior anthers furnished with awl-shaped appendages; capsule trigonal; valves opening with elasticity." As I understand the Viola distinct from the Pansy, so-called, but which is, I suppose, a hybrid Viola really itself, exhibiting the marked improvements of many years, the line of distinction should be drawn in the first sentence of the above quotation—viz., "Calyx with unequal sepals," a character not allowed in the florists' Pansy. But if we rigidly pursue this course we shall exclude the best Violas, such as Countess of Hopton, Lady Polwarth, Archie Grant, and all those whose flowers have the same rounded tendency; these, then, would go to the bedding Pansies, while such as Mrs. Gray, Elegans, Grievei, lutea grandiflora, and such like would be retained as Violas. But how are we to establish such a rule? We ask some of the veteran florists what the Pansy was fifty years ago, and is there no chance of our present race of Violas being improved also? I have before me a copy of the "Floricultural Cabinet" for May 1st, 1835, which contains a plate of Carnations and Pansies, two of each; the two former, which are rather a Picotee and Carnation, are equal to the best flowers of the day, while the Pansies, which are named Iver Beauty and Royal Crimson, could not well be equalled for their inferiority; but in successive volumes of the "Cabinet" the improvement in these is marked, until the unequal sepals of fifty years ago have reached the standard of our present florists. From the Violas of years ago we have great improvements, which, if continued, will end in well-rounded flowers. But Mr. Steel's remarks seem to refer to the exhibition board, upon which I stand neutral, though I hope to hear the opinions of some of the grey-haired veterans on the subject. Cannot our friend, Mr. W. Dean, help us?—E. JENKINS.

### KEEPING PLANTS CLEAN.

THIS important matter to all horticulturists is so well handled by your correspondent "B." in last week's Journal, that we would advise your readers to re-peruse the article. "B." sensibly bases his remarks on the principle that "Prevention is better than cure." After mentioning the fact that neglect in taking precautionary measures is the prime cause of the amount of injury wrought by insect pests, "B." puts a proposition with which all will cordially agree—viz., that "An insecticide that is at once cheap and quickly efficient is a desideratum that many hard-worked gardeners want." "B." however, errs in the conclusion he comes to in the next sentence. He also infers wrongly "that it is to America"—as he states in another paragraph—"that we are indebted for the first public intimation of the only safe and effective method of employing petroleum." In the interests of British trade and enterprise in horticulture we may be allowed to assert that two methods of preparing petroleum as an insecticide have for some time been before the public in this country. One of these—an "emulsion of paraffin,"—is apparently (we write without prejudice) very similar to the emulsion "B." describes, and we have heard it highly spoken of. The other, our own preparation, combines a preparation of petroleum by means of softening potash and other elements taken up with tobacco powder. We have by these means an insecticide strongly impregnated with petroleum, and which has the advantage of being applied in powder as it is put up, or by means of water for dipping or syringing. In using this insecticide in liquid we could not give more fitting directions than those given by "B." in his two latter paragraphs, and only add that the temperature at which the water may be applied is immaterial with us. We will readily place this insecticide at "B.'s" service, if he will investigate it for himself, and, if disposed, inform you of the results.—W. WOOD & SON, Wood Green.

### TWEED VINEYARD, CLOVENFORDS.

THROUGH the kindness of Mr. W. Thomson I was lately enabled to pay a visit to this far-famed Grape-growing establishment, and I was utterly astonished at the wonderful crops of Grapes. For the production of late-keeping Grapes Mr. Thomson erected four span-roofed houses, each 200 feet long and 24 feet wide, each having a sharp pitched roof. Two of the four large houses are devoted to Lady Downe's exclusively, and the Vines have an enormous crop of fruit, for there are 5000 bunches in the two houses of this variety alone. They are grand bunches, too, quite symmetrical, the berries closely set, and a badly set bunch or scalded berries are almost unknown here. Many shoots have two bunches which weigh from 2 lbs. to 2½ lbs. each, and the colour is sloc like. The Vines

have three and sometimes four branches to each—a kind of modified extension, allowing enough foliage without crowding. The young wood made annually is not very large, but short-jointed, ripe, and solid. The houses are heated with twelve rows of pipes, six rows being placed on each side, thus abundance of heat is obtained without heating the pipes unduly. Simple ventilating gear is supplied to the top and bottom front lights.

The other two houses of the same size as those devoted to the Lady Downe's are planted with Gros Colman principally, and present a most remarkable sight. There are over 4000 bunches hanging, and many of them weigh 4 lbs. each, the berries measuring 1½ inch in diameter. The berries and bunches from the top to the bottom of the Vines are wonderfully even, and were promising at the time of my visit (Sept. 8th) to finish grandly in colour. Some of the Vines are upon their own roots, while others are grafted upon different stocks, no difference being discernible except in the case of one Vine which is worked on Burchardt's Prince; the bunches here assume a tapering appearance resembling the Prince, the berries are very large and even. One Vine has as many as ten branches growing from one stem; another Vine, which has some of its branches through the partition into the adjoining compartment, has no less than 253 bunches, or a total weight of more than 5 cwt. of Grapes. At the end, on one side of one of the large houses, is growing a Vine of Alicante, which has thirty-nine bunches, every one fit to place upon an exhibition table.

A corridor from which three of the large houses named branch is 120 feet long by 24 feet wide; in this some very fine bunches of Duke of Buccleuch were hanging, being the remains of the crop, the berries large, free from the objectionable spot so often seen upon this variety, while the flavour was first class. Along with these were growing a few rods of Black Hamburgh, but this variety is giving way to later keeping varieties. Several other houses, principally lean-to in shape, are now devoted to Grapes. Pine Apples and plants for market used to be grown largely; these have all given way to Grapes. One low house previously used for Pelargoniums is now filled with a grand crop of Gros Colman. A former Pine stove is planted with Muscat of Alexandria; the crop was at the time of my visit nearly cleared, sufficient remaining to show the quality. The soil from its appearance does not appear to be particularly well adapted to Grape growing. Mr. Thomson depends almost entirely upon his Vine and plant manure, which he applies in the form of a surface dressing three times a year, and no manure of any other kind is now used. As showing the appreciation of his prepared manure generally it may be stated that as much as 94 tons were sold during the month of January last. Mr. Thomson considers that by increasing the application this year to his Vine borders he has added considerably to his crop of Grapes, which are estimated at 10 tons weight.

Orchids, too, are largely grown in this establishment. Special varieties are cultivated more than a collection of kinds, such as *Lelia purpurata*, *Dendrobium Leichianum*, *Cœlogyne cristata* (a fine stock), and *C. Massangeana*, of which large stocks are kept, all in splendid condition, reflecting much credit on Mr. W. Thomson, jun., who pays special attention to this branch of their trade, much of the management of the vineries devolving upon Mr. Thomson's second son, John, who may well be proud of his achievements in that branch. Any gardener having the opportunity to pay Clovenfords a visit should not fail to do so, for he is sure to receive a cordial welcome.—E. MOLYNEUX.

### THE UNITED HORTICULTURAL BENEFIT AND PROVIDENT SOCIETY.

AFTER an arduous existence of twenty-one years the Committee of this excellent and well conducted Society determined to celebrate the attainment of its majority by a dinner at the "Caledonian Hotel," Adelphi, Strand, which was held on Tuesday evening, October 11th. That the idea of such a reunion was well received may be judged from the fact that nearly eighty members and visitors were present, including a number of the leading metropolitan horticulturists, nurserymen, and seamen, to many of whom the Society was only obscurely known until quite recently. The result of a more intimate acquaintance with the objects and admirable method of management has been a considerable increase in the number of members, while at the meeting in question substantial additions were made to the list of honorary members. It is quite clear that all the Society needs is a greater publicity, and then, as the Treasurer, Mr. J. Hudson, remarked, the number of its members would rapidly advance beyond the present 200, although this is a total far exceeding what had been previously obtained. The principles of the Society are so good, and it is conducted upon such an unusually economical basis, that it would admit of an almost indefinite development with a proportionate increase of advantages to the members.

The chair was taken at 8 P.M., by Harry J. Veitch, Esq., who was supported by F. A. Paulbrick, Esq., Q.C., and W. Roupell, Esq., with Messrs. Weeks, G. Deal, Sherwood, J. Laing, Manning, G. Stevens, and W. Collins (Secretary). Mr. R. Dean was in the vice chair, the Treasurer (Mr. J. Hudson) and other officers of the Society also being present. After disposing of an excellent repast, the special business of the evening was commenced by the Chairman proposing the usual loyal toast, which was introduced in appropriate terms, with particular reference to the social and intellectual progress that has been made in the Queen's fifty years' reign. Following that on the list was the toast of "Continued Success to the United Horticultural and Benefit Society," coupled with the name of Mr. J. Hudson. Mr. H. J. Veitch, in a concise and excellent speech, reviewed the objects and position of the Society as follows—

As in all matters connected with the benefit of the human race no effort can be too great, we cannot do better at this, the twenty-first anniversary of the establishment of the United Horticultural Provident and Benefit Society, while looking back to see what has already been done, look forward

also to see if more cannot be accomplished. In regard to the Institution of which we are now celebrating the twenty-first anniversary, it will be in the recollection of many that it was founded by three gentlemen, to one of whom—Mr. Baker—I should like particularly to refer. He was unfortunately unable to be present here to-night, owing to his residing at so long a distance, but I recently had the privilege of spending a very pleasant day with him, and in the course of conversation this Society was referred to, Mr. Baker expressing his great interest in its progress. The other two gentlemen were Messrs. Heale of Hereford, and Rhodes of Sydenham, both of whom have now passed away. The Society, then, was formed by these three gentlemen in 1866, but after a few months it was thought well to add to the sick fund a benevolent fund.

The first object of the Society we find in Rule I., to which I will refer you. It is as follows:—"The objects of this Society are to render assistance to gardeners in time of sickness, calamity, and old age. Firstly, by allowing sick pay until the member reaches his 70th birthday, as stated in Rules XIV. and XV.; secondly, by assistance from the Benevolent Fund after attaining 70 years of age in time of sickness, or in seasons of distress, as stated in Rule XVIII." Nothing more noble than that could, I think, enter the thoughts of man. Subsequently to accepting the invitation to preside over this meeting I procured a copy of the rules and read them through very carefully, and I would say that, connected as I am with several benefit societies, I was struck by their liberality. Members can be enrolled from 18 to 45 years of age, and after contributing 2s. per month for twelve months are entitled to 10s. 6d. per week for six months in case of sickness. I would appeal to those present if any rules could be more liberal. Further, if members remain ill for a longer period than fifty-two weeks they are handed over to the Benevolent Fund for further assistance. I mention these matters to you as showing the very liberal terms of the Society. I also asked the Secretary for a few data as to the membership of the Society from its inception, and these, too, I will place before you. Few joined the Society at first. In its first year I gather that there were but 21 members, and the number increased very slowly; in the second year there were 31, in the next 40, and in succeeding years the figures were 41, 43, 42, and 44. Things went on in this way until 1876, when I find there were 66 members enrolled, in 1882 there were 96, and in 1883, 120. When I inquire the reason for the rapid increase during these years I am told that it is thanks to the cause of the Society being taken up by the Press, and that the result is more particularly due to the efforts of the *Journal of Horticulture*, which, by placing the advantages offered by the Society prominently before its readers, was the means of bringing in many members. The number at the end of last year was, I may add, 177.

I now inquire as to the sick pay, and, beginning with 1870, find that £16 14s. 6d. was paid in a membership of forty-three; in 1871, with forty-two members, £19 18s. 4d. was paid. Then going to 1876, I find £4 5s. 6d. paid; and in 1881, with eighty-eight members, only £1 11s. 6d. Thus it will be seen the payments vary very greatly. Certainly the Society may be congratulated on being in every form in a thoroughly healthy condition. In addition, a few inquiries into the payments of the Benevolent Fund show us that assistance was given to the widow of a deceased member to the amount of £6 10s. 6d., and in 1874-8-9 £18 8s. was expended in a similar manner. A somewhat similar case occurring not long ago, that of the widow of Mr. McElroy, the late Secretary, may be alluded to particularly. Mr. McElroy's work for the Society was purely a labour of love. Too old to become a member of the Society, he yet discharged the duties of Secretary for fourteen years, amongst them the most trying years the Society has had, and although the rules permit of £20 a-year being paid to the Secretary, Mr. McElroy steadily refused to accept anything beyond the small balance remaining over the working expenses. We ought therefore to pay an earnest tribute to the manner in which Mr. McElroy worked on the Society's behalf. I hope I may be allowed in passing to refer to another institution with which I am connected—namely, the Gardeners' Royal Benevolent Institution. When asked to come here it was suggested to me that my connection with the Society just named would render an acceptance of the invitation inadvisable, but I represented to myself that any institution having for its object the benefit of our fellow creatures is deserving of all support. Well, I have received from the Secretary of this Institution, of which Mr. McElroy was a member for eighteen years, an intimation to the effect that its members hope to put Mrs. McElroy's name down as a life member of the Institution in January next. I should like, in quitting this matter, to point out that a gardener being a member of one Institution by no means prevents him joining another.

The next question that arises as to the work of this Society is, "At what cost is it done?" This, in my opinion, is a very strong point indeed. Well, last year I find that the working expenses were less than 2s. 6d. per head in a membership of 177, and the figures speak conclusively as to the admirable management of the Society by the appointed officials. Though, as I have before remarked, a member of several societies, I know of none worked so cheaply as this. Members present may heartily congratulate themselves as to the present condition of the Society and as to its future prospects. The great object should be to get more members; the present number ought not to be considered satisfactory. Amongst thousands of gardeners there are but 177 in the Society, and as the Press has been of the greatest assistance in the past it is to be hoped that it will advocate the cause of the Society in the future.

There is one omission in the rules which I should like to call attention to—namely, the absence of any provision for making the Society more generally known. If concise circulars could be printed—they must not long, or they will not be read I am afraid—thousands could be distributed by asking your honorary members to enclose them in their packages and hampers after Christmas. Messrs. Laing, Sutton, Williams, and other nurserymen would, no doubt, willingly distribute circulars in this manner free of cost. If the funds of the Society cannot be devoted to the purpose, I would suggest the organisation of a special fund, and will gladly give £5 to aid it. The Society provides such great advantages that it is a pity it is not more widely known. Numbers would; I am convinced, be only too willing to join. We gardeners are a long-lived family, ranking next to parsons, I believe; and perhaps you will suggest that in this respect we distinguish ourselves in good company. Be that as it may, we have much to be thankful for, and as we look a pretty healthy lot, we should, if we could present ourselves in a body, no doubt do well. As we

cannot do this, we must adopt other means of making the advantages of the Society better known and securing increased membership [applause].

In responding, Mr. Hudson remarked that the officers and friends of the Society were deeply grateful to the Chairman for his kind and encouraging remarks, and also said how sensible they were of the great assistance that had been rendered by the Press, especially by the *Journal of Horticulture*. He considered that gardeners had an undoubted right to a benefit society of their own, and that, owing to their necessary sobriety and exceptional freedom from sickness, they were placed at a great disadvantage when joining the larger mixed societies. He referred also to the fact that no entrance fees or fines for non-payment of subscriptions were imposed, and there was no difference in the scale of payments at different ages, anyone joining between eighteen and forty-five years of age pay at the same rate and are entitled to the same privileges. If payments are discontinued after the lapse of a specified time the member is not entitled to relief in sickness, but the amount standing to his credit is retained, and at the age of sixty it is repaid to him without interest, or, in case of previous death, to his nominee. By means of the Benevolent Fund also, it is possible to considerably extend relief in deserving cases. As an instance, he noted that a widow of a member had been recently paid £34, and when she died shortly afterwards £20 were voted to the orphans. He had found on calculation that their death rate was a very low one—namely, 7 per 1000. At the last annual meeting there were 177 members, but they had now advanced to 200, and he earnestly hoped that they would some day reach 1000, and he was convinced that this might be accomplished. He concluded by proposing the Hon. Members, coupled with the name of Mr. Sherwood, of Messrs. Hurst and Son, and observed that there were now twenty-two honorary members, as compared with eleven last year.

Mr. Sherwood returned his most sincere thanks for the honour that had been paid him, and observed that he was glad he had accepted the invitation to attend the meeting, as, though he heard but little of the Society until recently, he was convinced that it thoroughly deserved the support of all who could give it. Its usefulness is undoubted, and the more it is known the greater will be its success.

Mr. W. Roupell in proposing the health of the officers of the Institution coupled with the names of Messrs. Wheeler, Cole and Collins, said that their motto, "Union is Strength," was an excellent one, and he hoped they were all united there in the desire to further the aims of so admirable an institution, and to signify his willingness to assist he wished to become an honorary member. He remarked that in the majority of charitable institutions or benefit societies much was wasted in the management, or at least was not expended to the full advantage of the members or intended recipients. By reference to the balance-sheet of this Society he was, however, surprised and pleased to see how economically the affairs were managed, the only charge being 2s. 6d. per annum for each member. Mr. J. Wheeler replied in a few fitting terms, stating that it gave him much pleasure to see such a gathering of old and new friends. Mr. Nathan Cole also expressed his thanks, observing that he had been present at the birth and christening of the Society, and was delighted to see its coming of age celebrated in such a remarkable manner. As one of his friends had stated, the Society was in such a weakly state at one time that it was proposed to call in a doctor to its assistance, that doctor was Dr. Hogg, who could not come himself but he sent the (Wright) man, and the right man did the right thing, and the weakling had grown stronger ever since. Mr. W. Collins also replied in a few appropriate terms.

Mr. F. A. Philbrick, Q.C., proposed the Horticultural Press, and commented in most flattering terms upon the services rendered to every good object connected with horticulture. The reports in the Press were of great importance in disseminating a knowledge of and increasing a love of the art of gardening. He considered that engaging in horticulture, either as an amateur or professional, was one of the most ennobling pursuits, and the Press in encouraging this was conferring a benefit upon the community generally.

Messrs. Wynne and Gordon, in responding, said that the Press was always willing to assist in any deserving cause that was brought under the notice.

Mr. Bery then proposed the Horticultural Builders and Seedsmen, which was replied to by Messrs. Laing and Weeks in a few words.

The health of the Chairman, Mr. H. J. Veitch, was proposed by Mr. R. Dean, who referred to the readiness with which he had always given both pecuniary and earnest social support to all matters beneficial to gardeners, and noted his connection with the Gardeners' Royal Benevolent Institution as Treasurer, and the handsome donation of £100 recently made to the Gardeners' Orphan Fund. He also noted the wonderful services that had been rendered to practical horticulture by the three generations of Veitches, which at Exeter, and then at Chelsea, had developed such a widely famed business. This toast was received with acclamation, and Mr. Veitch returned his cordial thanks for the manner in which the toast had been welcomed; and after Messrs. G. Daal and Manning had made a few remarks as visitors who desired to become honorary members, votes of thanks were accorded to the dinner stewards and Messrs. Thomson & Sons of Cleverfords for the Grapes sent, the meeting terminated.

#### ROYAL HORTICULTURAL SOCIETY.—OCTOBER 11TH.

THOUGH flowers and plants were not quite so numerous as usual, there were a few novelties—some fine Chrysanthemums and Dahlias, and a small group of Orchids. The Apples from Chelsea and the vegetables in competition for the special prizes alone constituted an exhibition of considerable interest, the vegetables being of exceptional merit.

FRUIT COMMITTEE.—Present—T. Francis Rivers, Esq. (in the chair), and Messrs. John Lee, William Paul, T. B. Haywood, A. H. Pearson, G. T. Miles, T. J. Saltmarsh, G. Norman, J. Woodbridge, F. Rutland, H. J. Veitch, F. Burnett, Philip Crowley, G. Bnyard, R. D. Blackmore, and J. Fitt.

Mr. W. Roupell, Harvey Lodge, Roupell Park, exhibited a plant of Duke of Buccleuch Grape grafted on White Frontignan, the wood ripened earlier and produced a lateral fruit-bearing shoot the first year. A plant of Muscat of Alexandria in a pot, and bearing eight good bunches, very clean and well ripened. Remarkably clear, highly coloured bunches of Muscat of Alexandria from Vines grown in pots, in warm pits, and ripened chiefly by sun heat were sent; they were of first-rate quality. Fine bunches of



Madresfield Court were also shown, and a vote of thanks, with a cultural commendation, was awarded. Messrs. James Veitch & Sons, Chelsea, contributed a similar extensive and meritorious collection of Apples and Pears to that noted in the report of the Crystal Palace Show, a silver Banksian medal being awarded. Mr. T. Bate, Kelserton, Flint, sent samples of an Apple believed to be a seedling from Ribston Pippin, but the Committee thought it was Trumpington. Messrs. W. Johnson & Sons, Boston, sent a collection of Pears, mostly small, but including some good samples. Mr. W. Divers, The Gardens, Wierton House, near Maidstone, sent fruits of the Brunswick Fig, Beurré d'Amanlis Pear, and a seedling Plum, a standard on its own roots, which always bears abundantly, and is valued for kitchen use. Mr. Palmer, Thames Ditton House, Surrey, had fine samples of Veitch's Red Globe Turnip, and a neat seedling Tomato. M. Victor Dürfeld, Olbernhau, exhibited some very fine models of Apples and Pears that were specially commended. Mr. T. Perry, Ye Olde Lodge, Sonthall, sent fruits of a large green-striped Melon from the Soudan.

First-class certificates were awarded for the following:—

**Apple Bismarck** (J. Veitch & Sons).—A handsome Apple, 4 inches in diameter, 3½ deep, eye closed with long segments in a deep depression slightly plaited; stalk short, thick, in a deep basin. Colour greenish white, heavily streaked and suffused with red on the side towards the sun. Flesh firm and of good brisk flavour. The variety is one of the Emperor Alexander type, and was introduced from New Zealand a year or two since.

**Apple Gascoigne's Scarlet Seedling** (Mr. Gascoigne, Maidstone).—A free-fruited variety of the Duchess of Oldenburgh type, slightly conical, yellowish white, with a deep red colour on the side exposed to the sun, and having a delicate wax-like bloom. The flesh is crisp and the flavour agreeable.

**FLORAL COMMITTEE**.—Present: G. F. Wilson, Esq. (in the chair), and Messrs. H. Bennett, J. Douglas, J. Fraser, G. Duffield, H. Herbst, W. H. Lowe, J. Walker, J. Hudson, W. Holmes, R. Dean, D. Noble, C. Pilcher, H. M. Pollett, J. Dominy, A. L. Landy, J. O'Brien, E. Hill, H. Turner, W. Goldring.

Mr. G. Stevens, St. John's Nursery, Putney, contributed a beautiful collection of Chrysanthemum blooms, comprising forty-eight beautiful flowers of Mdle. Lacroix, pure white, large, full, and excellent (vote of thanks). The other varieties were also Japanese, including Mons. H. Jacotot, deep crimson; Alfred Cbantrice (Delaux, 1886), bronze yellow; G. Wrigley (Delaux, 1886), flat florets rosy crimson, white reverse; M. Cossart (Delaux, 1886), a compact bloom, short florets, fluted, reddish bronze to yellow; Feu de Bengale (Delaux, 1887), narrow long twisted florets, bronze yellow; Thomas Stevens (Stevens, 1887), a pretty variety with flat florets slightly tinted at the tips, tinged pale purple, white centre; Macbeth (Delaux, 1887), long narrow florets, bright clear yellow; James Stevens (Stevens, 1887), long drooping florets, bronze red, full and good; Ormonde (Delaux, 1887), florets long, drooping, twisted, bright yellow; and Rose Stevens (Stevens, 1887), a useful decorative variety, somewhat similar in colour to Belle Paule, a dozen good blooms of this were shown. A pretty reflexed variety, Elsie (Cannell, 1887), creamy white, very good; and Martinus (Delaux, 1887), a small reflexed of a rosy tint; and a neat Pompon named Miss L. Stevens, pure white. Mr. W. Holmes, Hackney, had a stand of a dozen Chrysanthemum blooms in four varieties, one of which, L'Africaine, was certificated. The others were Mdle. Lacroix, Romeo, deep crimson maroon, and O. J. Quintus, lilac blush, fluted florets, very pretty.

F. G. Tantz, Esq., sent a plant of the distinct and pleasing *Cypripedium Fairieanum*, bearing three flowers, and *C. Harrisianum superbum*, which was certificated. Mr. C. J. Salter, gardener to J. Southgate, Esq., Selborne, Leigham Court Road, Streatham, was adjudged a vote of thanks for a raceme of *Aerides Lawrencei* (Southgate's variety) with thirty-nine unusually large flowers, the sepals and petals white tipped purplish crimson, the lip of similar colour. A dark brown and yellow *Oncidium* was also shown. Mr. Sharp, gardener to A. Curle, Esq., Prionwood, Melrose, N.B., was awarded a vote of thanks for flowers of the peculiar greenish yellow *Cynoches chlorochilon*. Mr. Ballantine, gardener to Baron Schröder, The Dell, Staines, showed a plant of *Cattleya porphyrophlebia*, with medium sized flowers, delicate pale bluish sepals and petals, the lip rich crimson in the centre, white at the margin.

A bronze Banksian medal was awarded to Messrs. J. Veitch & Sons, Chelsea, for a collection of their varied and handsome *Rhododendrons*, the variegated *Impatiens Sultani*, *Phrynium variegatum*, and the deep rose coloured *Begonia John Heal*. From the Society's gardens, Chiswick, plants of *Hedychium Gardnerianum* were sent, bearing strong heads of its fragrant yellow flowers. Messrs. H. Cannell & Sons, Swanley, showed a basket of the fine double white *Tuberous Begonia*, Octavia, remarkable for its symmetrical shape, also a number of handsome single and double *Tuberous Begonia* blooms. Mr. R. Dean, Ealing, was adjudged a vote of thanks for examples of the double pure white *Dianthus Heddewigii* Snowdrift, *Gaillardias*, and the brilliant blue *Phacelia campanularia*. A vote of thanks was accorded to Messrs. Rawlings Bros., Romford, for seventy-five fine blooms of Show and Fancy Dahlias, capital blooms, good in size and colour. Mr. T. S. Ware, Tottenham, showed plants and flowers of the bright purple *Stokesia cyanea*, several varieties of *Tritoma*, including T. Metschi, a garden hybrid in which the flowers open from the top of the scape downwards. Plants of the bright crimson *Nerine sarniensis* and the scarlet *N. venusta* were also shown, and a vote of thanks was accorded. Mr. G. Prince, Oxford, exhibited a number of dwarf Tea Roses on seedling Briar, one and two years old, very strong and excellent samples.

**CERTIFICATED PLANTS**.—*Chrysanthemum L'Africaine* (W. Holmes).—A Japanese variety sent out several years ago, and known in some collections as George Gordon. The florets are broad, flat, brilliant crimson, with a pale gold reverse, and when seen as Mr. Holmes showed it the variety is very ornamental. Unfortunately many have proved it too unreliable to be of much value, and it was a matter of surprise that the Committee had awarded it a certificate.

*Chrysanthemum Wm. Cobbett* (Stevens).—A Japanese variety raised by Delaux, sent out this year. The florets are broad and flat or very slightly fluted, of a rich rosy salmon hue when first opening, becoming paler. A promising variety.

*Cypripedium Harrisianum superbum* (F. G. Tantz, Esq.).—A grand variety with large flowers, the dorsal sepal broad, edged white, and deeply

veined with blackish purple; the petals are broad, margined with hairs, and of similar colour, the lip being slightly lighter. The whole flower has a shining appearance, as if polished.

**SPECIAL PRIZES**.—The vegetables in competition for Messrs. Sutton and Sons' prizes formed an unusually fine display, the good quality of the exhibits and the taste in the arrangement rendering the collections remarkable. The Judges had considerable difficulty in selecting the winners from the eight exhibitors. Mr. W. Pope, Highclere Castle Gardens, Newbury, was awarded the first prize for admirably grown samples of Sutton's New Intermediate Carrots, Prizetaker Leek, Veitch's Main Crop Onions, Reading Exhibition Brussels Sprouts, Autumn Giant Cauliflower, Sutton's perfection Tomatoes, Chancellor Potatoes, very fine one; Veitch's Early Rose Celery, fine solid heads. Mr. C. J. Waite, Glenhurst Gardens, Esher, was a close second, showing good beads of Wingrove's Prize Red Celery, Sutton's Intermediate Carrots, fine Perfection Tomatoes, Michaelmas White Broccoli, Reading Exhibition Brussels Sprouts, and Rowham Park Hero Onions. Mr. S. Haines, The Gardens, Colesbill House, Highworth, was third, his strongest dishes being Anglo-Spanish Onions, Perfection Tomatoes, Autumn Giant Cauliflowers, and Lyon Leeks. Mr. A. Waterman, Preston Hall Gardens, Aylesford, was fourth with Sulham Prize Celery, Autumn Giant Cauliflowers, Snowdrop Potatoes, and Canadian Wonder Beans in excellent form. Mr. T. Wilkins, Inwood House, Blandford, was fifth with fine solid white Celery, London Hero Potatoes, Perfection Tomatoes, and Sutton's Prize Leeks.

There were twelve competitors in Messrs. Sutton & Sons' class for Scarlet Runners, Mr. R. Lye winning the first place with even pods 10 inches long. Mr. W. Palmer, Thames Ditton House Gardens, was a close second, Mr. C. J. Waite third, and Mr. W. Pope fourth.

Messrs. J. Carter & Co.'s prizes for a dish of their Champion Runner Beans brought ten competitors, all exhibiting capital specimens. Mr. J. Bunting, Holtwhites Hill, Enfield, was first with very even specimens, 9 inches long. Mr. C. J. Waite was second, and Mr. P. Cornish third.

The third prize was awarded to Mr. F. W. Edgcomb, St. Mary Cray, for a dozen roots of Carter's White Emperor Onion, the only exhibit.

Messrs. Webb & Sons' prizes for their Improved Banbury Onions were awarded to Messrs. E. S. Wiles, T. A. Beckett, and W. Pope, amongst six competitors, all of whom had fine solid heavy samples.



#### HARDY FRUIT GARDEN.

**REGULATING WALL TREES**.—Most of the wall trees are now sufficiently matured to admit of their being transplanted safely, and a better time for the work could not well be chosen for regulating or re-arranging them. Some sort of system should be introduced where necessary, or where there is a general mixture on nearly all the walls. For instance, a very sunny south wall ought not to be occupied largely by Plums, Pears, and Cherries. It is in these positions where the choicer Peaches, Nectarines, Apricots, and Figs should be grown. Cherries thrive admirably against walls with either a west, south-west, or south-east aspect, though as far as our experience goes they scarcely merit a great amount of valuable wall space. Good dessert Cherries can usually be bought much more cheaply than they can be grown and preserved by nets, and in very many instances the wall space might be much more profitably devoted to Pears. The latter in all southern and most midland districts can be grown to perfection against walls of south-west, west, east, and south-east aspects, and in favoured districts a few sorts will do well even against a north wall. In the less favoured northern districts we would devote the principal portion of the sunniest walls to Pears, no other hardy dessert fruit being in greater demand or more acceptable in most establishments. Plums we would relegate to the walls with east, south-east, and north-east aspects, and in the sunny south even the north walls appear to suit them, and it is with the aid of these and other somewhat cool aspects we contrive to maintain a long succession of Jefferson, Gages of sorts, Kirke's, Victoria, and Coe's Golden Drop, and other favourite Plums. The Morello Cherry really requires a cool site, and it is the walls with a north or northern aspect that should be profitably occupied with them. Figs succeed admirably in the southern counties, especially along the coast, and many more of the wholesome and as we find much appreciated fruit might well be grown against the open walls. If there is a hot sunny corner formed by the union of a west with a south wall this is just the spot for Figs. Planted in poor loam, to which lime rubbish has been freely added, the trees form sturdy short-jointed growth that is both fruitful and hardy. American Blackberries thrive best and are most fruitful against a wall. Years ago we saw a high wall in a frame-ground connected with a Sussex garden fully clothed with these Blackberries, and which had immense clusters of fine fruit beautifully ripe in August and September.

**TRANSPLANTING THE TREES**.—As Peach, Nectarine, and Apricots are liable to gradually lose the principal portion of the branches—the Apricots especially so—and seeing that these occupy the most valuable sites, with perhaps a glass coping overhead, young trees of each should be in readiness to take their place directly they cease to be profitable. We "feed" our south walls with trees prepared against a south-west wall, and quite large trees, providing they are not very old, can safely be transplanted without the loss of a crop. Sometimes it is advisable to shift good trees into a Peach house, replacing these with others from



a cooler site, and filling up the blanks in the latter with young trees from a nursery. All this means a little extra labour and some expense, but it is always wise to utilise the best positions to their fullest extent. If we wait till the old trees collapse and then fill their places with the best that can be procured from most nurseries, much valuable wall and house space is wasted for some time. Almost any tree that has not occupied its present site, say more than twelve years, may, as a rule, be moved safely, and if the work is carried out in a thorough manner they will be improved by the operation. Before transplanting a tree see that the proposed site for it is well prepared. Wherever an old tree has long been standing, the greater portion of the border within a half-circle of about 6 feet in diameter will be totally unfit for the reception of a fresh tree. A depth of about 6 inches of soil may usually be thrown back, but at least a good spit under this ought to be wheeled clean away, and a fresh compost consisting, if possible, of equal portions of turfy loam and fresh garden soil be substituted. If all fresh loam could be used so much the better, and plenty of burnt garden refuse, and in the case of heavy soils lime rubbish, will always improve the compost. Quite young trees should have no solid manure in the soil, but we usually add a little for the larger trees, and crushed bones also when we can get them. Starvation treatment is very wrong in the case of wall trees, these meriting more liberal treatment than any kind of vegetable, yet the latter usually have all the best of it.

The trees to be moved ought not to be unnailed or released from the walls till the roots and intended ball have been well undermined. First open a wide trench, in some cases fully 6 feet from the stem of the tree, gradually and carefully undermine the roots, using forks principally for the work, with the idea of saving as many of the fibres as possible. Do not attempt to save a larger ball of soil than those doing the work are capable of lifting and carrying. Cleanly cut through all deep running roots, lighten the ball on the top, and make the bottom as flat as possible. Next work under the ball and stem of the tree either a short, wide, and strong board, such as can be got comfortably into the hole, or a short legless handbarrow, then unfasten the tree and let it settle on this, when it can then be carried to its new site, and at once slipped off to where it is to remain. Plant rather above the surrounding level to allow for sinking, all bruised roots being cut back, and the points of the remainder cleanly cut across, then spread out evenly and thinly much as they spring from the stem and covered with some of the finest of the soil, making this fairly firm about them. Only temporarily fasten the trees to the wall, or otherwise they will not settle with the soil, and if there are leaves yet hanging it may be advisable to give a good soaking at the roots, and an occasional overhead syringing. All newly planted trees should have a mulching of strawy manure, this saving the already mutilated roots from further injury from frosts. The warmth enclosed may also assist the roots in healing and forming fibres before the winter sets in. Much that has been advised in the case of the wall trees is also applicable to various kinds of fruit trees in the open ground, and which also well repay for a little extra attention occasionally.

#### FRUIT FORCING.

**MELONS.**—The end of the Melon season is approaching, especially as regards those grown in frames and pits heated by fermenting materials. though fairly well flavoured fruit may be had up to November, especially of Scarlet Premier, which is one of the very best for late work, and has the advantage of keeping a considerable time, therefore continuing the supply to a late period. Any fruits approaching ripeness should be cut with a good portion of stem, and placed in a house with a gentle warmth, where they will ripen and be welcome additions to the dessert.

In houses the supply will be kept up for some time longer, indeed our latest fruits are only swelling. Sufficient moisture will be secured to this crop by damping in the morning and again early in the afternoon, affording water to the roots moderately—a supply once a week will be sufficient. All superfluous laterals must be cut out, so as to afford the principal foliage the benefit of the autumn sun. Plants with fruits approaching ripeness should be kept dry, and a brisk heat maintained with rather free ventilation, the temperature being kept at 65° at night, 70° to 75° by day, rising to 85° or 90° from sun heat, affording a little air at the upper part of the roof whenever the weather is favourable.

**CUCUMBERS.**—Place out the latest plants which are to afford a supply of fruit about the new year on ridges or hillocks, training with a single stem to the trellis, up which they may be allowed to advance about two-thirds, when the lead may be pinched. Those not having the convenience of a Cucumber house may secure fair supplies of winter fruit by growing the plants in pots or boxes, training the growths near the glass over the pathways in stoves, fruiting Pine houses, or other heated structures. Plants in bearing should not be overcropped or the fruit allowed to remain longer than it is fit to cut, removing all deformed fruit in a young state. Maintain a night temperature of 70°; 5° less in the morning; 75° by day, up to 85° with sun, admitting a little air at the top of the house at every favourable opportunity. The evaporation troughs should still be charged with liquid manure, and the floors damped about 8 A.M. and 4 P.M., dispensing with the syringe. Reduce the supply of water at the roots, but not so much as to cause flagging. A few horse droppings sprinkled on the beds occasionally will benefit the plants through the waterings and the ammonia given off. Keep the foliage thin and the glass clean, so as to secure thoroughly solidified growth.

**STRAWBERRIES IN POTS.**—The autumn and winter fruiting plants must, without further delay, be placed under glass and on shelves, so

that they may enjoy a free circulation of air, ventilating so as to dispel damp, as the fertilisation of the flowers is not satisfactorily effected in a moist atmosphere. Those swelling and ripening the fruit in frames should have moderate ventilation, and though the fruits will swell and ripen in cold frames they swell better and the flavour is improved in a house where there is a moderate degree of heat, 50° to 55° as a minimum and 70° to 75° as a maximum by artificial means.

Plants for next year's fruiting are unusually late. They are neither so strong nor the crowns so well matured as they should be at this time of year. Those intended for early forcing should be placed on a base impervious to worms in frames, or cold pits, exposing them fully to every gleam of sun, employing the lights only to ward off heavy rains, and at night keep the remainder in a sunny situation, as they will require every ray of light and sun's warmth to enable them to mature the crowns properly.

**PEACHES AND NECTARINES.**—*Earliest House.*—The trees are at rest, and very promising they are. The buds are not too large—a good sign, and, through the lights being removed some time, the horders have been thoroughly moistened, therefore there is no fear of the buds falling. The trees should be pruned, dressed with an insecticide, and the whole of the house thoroughly cleansed. The trees should also be tied to the trellis, everything forwarded so that a start can be made without delay when the proper time arrives. The lights must remain off until the time of closing the house, or, if the lights are fixed, which is a great mistake, the inside border must not lack moisture, and air must be given to the fullest possible extent.

*Second Early House.*—The trees are casting the foliage. Our roof lights have been removed, as the trees have made stronger wood than usual, and that takes more time to mature than the moderately vigorous. The exposure of the trees has an invigorating tendency; it insures perfect rest, and the rains do much to free them of insects, besides soaking the borders. When the foliage is all down the necessary pruning, dressing with an insecticide and cleansing the house should be proceeded with, removing the surface soil down to the roots, and replacing it with fresh material, but not covering the roots deeper than 3 or 4 inches. In the case of fixed roof lights watering may be necessary; under no circumstances must the trees be allowed to become dry at the roots.

*Midseason Houses.*—The trees in these are just in the proper condition for lifting. It should be done with dispatch, all the materials being in readiness. Provide efficient drainage, shortening back any strong roots, and bringing any that are deep nearer the surface, employing the compost moderately firm. Good loam, rather strong, with an admixture of a sixth of old mortar rubbish and a sprinkling of about a fortieth of crushed bones and a like proportion of charcoal, will grow Peaches and Nectarines perfectly. If the soil be light add a fourth of clayey marl, and if very strong a similar quantity of road scrapings. Avoid manure, except at the surface. Give a good watering and the trees will soon get established in the fresh compost. Trees judiciously treated at the roots whilst they have foliage seldom fail to set and stone the fruit satisfactorily. Borders that have the surface a soapy mass and it is not possible to remove it may have a good dressing of quicklime quite an inch thick, mixing it with the surface soil as deeply as the roots allow without much disturbance.

*Latest Houses.*—Our last dish was gathered to-day (October 6th), but we have none later than Sea Eagle, a large, showy, and good flavoured fruit, with a juicy melting flesh. It is one of the best late sorts, devoid of the stringiness and mealiness too prevalent in some late Peaches. As the wood is not too ripe the house is almost closed by day so as to secure a good heat, there being of course enough ventilation to ensure a circulation. Any trees that have too gross wood should have a trench taken out as deep as the roots and about one-third the distance from the stem the trees cover of trellis, and left open for a fortnight, then filled in again firmly.

## THE BEE-KEEPER.

### PRACTICAL BEE-KEEPING.—No. 20.

SOME bee-keepers desire to increase the number of their stocks, and at the same time to obtain a moderate surplus of honey for sale or home consumption. Others are compelled by peculiarities of the season or by the absence of bee flowers at certain periods of the year to adopt a system suited to their special requirements. In a former article the circumstances which make the adoption of a moderate increase system not only advisable but actually essential to a profitable management have been discussed, and it is therefore only necessary now to point out the best method of taking less than an ordinary swarm from each stock.

The principle of the proportionate increase system is to make two, three, or even more strong stocks each yield their quota of bees or comb, brood, and honey. The

end achieved by this plan is that while not depopulating any stock beyond what it is well able to afford, yet a strong swarm, and one which cannot fail in an average season to yield a good surplus, is obtained. Every bee-keeper is aware that a large swarm is more profitable than a small one: true, it is said that after a certain weight—6 lbs. I believe—extra weight of bees do not give a corresponding advantage, but, generally speaking, it may be taken for granted that the larger the swarm the more profitable it will be. If, in addition to this, we are able to take the large swarm early in the season the profit will be greatly increased unless the weather is most unpropitious. Now in taking an artificial swarm from one stock the chief fact which we have to keep in mind is that if too large a swarm is taken the stock will be depopulated to such an extent that it will be a very considerable time in regaining strength, and may quite possibly not recover that year. In taking one swarm from several stocks we may make the swarms as large as we like, because if three stocks cannot afford the necessary bees and combs we may call to their assistance even a fourth or fifth stock. Again, a swarm taken from several stocks is, if one system is pursued, furnished at once with combs of brood and store, and thus in effect becomes a stock, and consequently rapidly forges ahead of swarms taken in the more usual manner. In addition to this a swarm provided with built out combs, some empty, some stored with honey and pollen, and some filled with brood in various stages of development, actually increases in strength day by day, while the swarm provided even with built out combs certainly decreases in strength until the eggs deposited by the queen of the swarm begin to hatch. This fact is of itself an immense advantage, and should not be forgotten. Add to this the fact that the stocks from which a part of a swarm only is taken scarcely feel the loss, and are therefore in a fit condition for supering when stocks from which a large increase has been taken in the ordinary way are still comparatively weak in number, and the case in favour of the methods about to be described for the benefit of those whose circumstances demand a small increase seems made out.

In the case of skeps the most practical method, and one followed with almost invariable success, is to drive all the bees and queen from one stock and to place the swarm thus taken on the stand of the stock removed, placing the stock itself on the stand of another strong stock, and removing the latter to a new position. The whole of this manipulation should be performed in the middle of a fine, warm, sunny day when bees are flying freely; it will then be attended with certain success. A fertile queen should be introduced to the stock from which the swarm was taken, otherwise the bees will have to raise a queen, and considerable time will be consequently lost. The same method may be adopted with frame hives, but there are many variations which simplify the operation when manipulating hives with moveable frames of similar size.

If, for instance, there are six colonies in the apiary, and all are strong enough to yield for swarming purposes a couple of frames of brood, an increase can very easily be taken. Two frames of brood must be taken from five of the stocks; the adhering bees, and also the queen if she is on the combs, being brushed or shaken back into their respective hives, and frames of foundation being inserted in the place of the removed frames, taking care not to place the frames of foundation together but placing a frame of brood between them. From the sixth stock the queen and a few bees only need be taken, and these

being placed in a hive containing the ten frames, the hive containing these frames must be placed on the exact spot occupied by the stock from which the queen was taken. It perhaps simplifies the matter to take the frame on which the queen is seen and the adhering bees from the stock and to place the frame in the centre of the ten frames. This, however, is not at all necessary, but there is less danger of injuring the queen. All this manipulation must be performed in the middle of a fine sunny day, and if the combs removed to form the swarm do not contain a few pounds of honey, syrup must be given until outside supplies yield sufficient to render such assistance unnecessary. Another method is to remove five combs of brood—not taking the queen or any bees—from a stock and place them in an empty hive, alternating between each comb both in stock and swarm a frame of foundation. A comb of brood with adhering bees and the queen must now be removed from another colony, and this frame placed in the centre of the hive containing the removed frames, and this hive being placed on the stand of the stock from which the one frame of brood and queen was taken the operation is complete. One stock will now be queenless, and will therefore require attention.

The great drawback in artificial swarming is the fact that driven bees return to their own stand. This may be obviated by the bee-keeper making an exchange of bees with another residing not less than two, or, still better, three miles distant. It is often most convenient, and profitable therefore, to exchange some dozen pounds of bees at swarming time, because when this can be done all the bees and their queen may be taken from a stock, and the stock being removed to any desired position sufficient of the bees from a distance may be given to the stock to rear its brood, and if necessary to raise a queen, and there is therefore no necessity to resort to what may seem to some to be the more intricate and difficult methods of proportionate increase.

In concluding this description of swarming methods allusion must be made to "nucleus swarming." My experience of this method is very slight; but as it is a favourite plan with some bee-keepers of great experience it will be only fair to describe it. The plan is well described in the "British Bee-keepers' Guide Book" in the following words: "Examine one of the nucleus hives in which a queen has been reared, and if she has commenced laying eggs confine her in a queen case. Remove the division boards, and fill up the hives with frames containing empty comb or comb foundation. Now remove a strong stock to the stand occupied by the nucleus, and place the latter where the stock stood." The flying bees thus entering the nucleus take care of the brood, and "after thirty-six hours the queen in the nucleus may be liberated." A fine day and strong stocks are necessary in this as in all the manipulations above described. It will be necessary to describe the formation and management of nucleus hives in a future article; but it may be well to explain that a "nucleus" is a small stock consisting of a few frames of brood and honey—generally three—used for queen-raising.

To those bee-keepers who are already acquainted with the rudiments of apiculture it may seem prolix and unnecessary to describe so fully the simplest manipulations, but many bee-keepers who have as yet all their practical experience to acquire are eagerly in search of the most detailed instruction on the simplest points. To take anything for granted means vexation for a beginner searching for information, and bearing out the smallest detail in describing a simple manipulation, is very often the cause

of failure when the operation is attempted by one who cannot bring practical experience to bear on theoretical knowledge.—FELIX.

P.S.—I must ask “A Lanarkshire Bee-keeper” to excuse my delay in replying to his criticism on these papers. My time, however, is so completely taken up that it is impossible for me at present to do so. In the course of a few weeks I hope to have the pleasure of “breaking a friendly lance” over one or two points. In his criticism on “No. 18” I think “A Lanarkshire Bee-keeper” has misapprehended my meaning, and I must confess to not being able to grasp the point of his criticism with reference to “queen cells” in stocks from which swarms have issued.—FELIX.

TRADE CATALOGUES RECEIVED.

Dick Radclyffe (Limited), 128 and 129, High Holborn, W.C.—List of Bulbs, Stoves and Ornaments.  
Martin Grashoff, Quedlenburgh (Germany).—List of Novelties.



All correspondence should be directed either to “THE EDITOR” or to “THE PUBLISHER.” Letters addressed to Dr. Hogg or members of the staff often remain unopened unavoidably. We request that no one will write privately to any of our correspondents, as doing so subjects them to unjustifiable trouble and expense.

Correspondents should not mix up on the same sheet questions relating to Gardening and those on Bee subjects, and should never send more than two or three questions at once. All articles intended for insertion should be written on one side of the paper only. We cannot reply to questions through the post, and we do not undertake to return rejected communications.

Insects on Chrysanthemums (W. M.).—The leaves sent are attacked with a species of aphid, of which there are several, some attacking the Rose, others the Dahlia, others fruit trees, &c. All these plant-lice differ in colour somewhat, but are members of the same family, the one before us being the Chrysanthemum louse. They will injure the plant if not destroyed by an insecticide.

Chrysanthemums (James).—You can strike the “strong healthy looking cuttings” now, though we fail to see what advantage you will derive from doing so, as we suspect you will have some difficulty in keeping the plants sturdy through the winter.

Tomatoes (S. O. L.).—All the fruits that are showing signs of colouring in the open air will ripen if cut now and suspended in a warm glazed structure or room, but will not attain such a rich colour nor develop the same high flavour as those ripened on the plants in summer.

The Mammoth Gourd (M. C.).—You are in error in stating that no answer has been given to your letter. Please refer to page 305 last week and see the second reply in the column.

Rose William Allen Richardson (Mrs. L.).—You have been misinformed. So far from its being a weak and bad grower we find few Roses grow more satisfactorily. It is suitable for growing against a wall, and in good soil, and kept clean, soon covers much space, affording flowers in abundance till the approach of frost.

Pelargoniums in Winter (J. D. F.).—Zonal Pelargoniums do not flower well and continuously in winter in greenhouses of mixed plants, and where the temperature often falls to 40° or lower. The position for these plants cannot be too light in winter, and a temperature of about 50° is desirable.

Large Cauliflowers (E. Adams).—In reply to your question as to whether “a large, splendid, crisp, solid head of Veitch’s Giant cut up into half a dozen smaller heads, is not then as suitable for table as if the small heads were grown on so many miserable plants?” we are inclined to answer in the affirmative, but every case must be judged on its own merits. Your superlatives indicate something wonderful even in the way of this fine Cauliflower.

Salting Asparagus Beds (F. Mason).—We think your employer is wrong in insisting on giving the beds a heavy salting as soon as they are cleared in the autumn, on the ground that salt has a tendency to keep the soil very wet in winter without any compensating advantages. We prefer its application in the spring, and as often as is necessary in the summer, for preventing the growth of weeds. Weeding Asparagus is a tedious process, and allowing the beds to be crowded with weeds is wasteful, as they abstract the virtues of the soil and manure that are necessary for the

production of strong Asparagus. Show your employer this reply, then do as he tells you. Some persons like to have their own way even if it is not the best, and in matters of this kind it is well to remember the old saying, “Those who pay the piper have a right to choose the tune.”

Luxuriant Peach Tree (P. Owen).—No trees lift better than do Peaches, and replanting yours, shortening some of the strong roots, would be certain to do it good. Turfy loam, with a liberal admixture of lime rubbish and wood ashes, would be suitable for placing round the roots. A firm and not very deep border will answer your purpose, mulching well in summer for keeping the roots near the surface. If you cannot lift the tree, cut off some of the strongest roots, paring the ends smooth with a sharp knife.

Lifting Vines (E. G.).—As the Grapes are “perfectly ripe,” and you are anxious to renovate the borders, we should cut the crop at once, inserting the laterals bearing the bunches in bottles of water, and suspending these in a room where the temperature is equable—45°, or thereabouts. As the leaves are fading you may remove them from the severed laterals, but we should allow those on the Vines to remain, as several of them may be fresh enough to encourage fresh root action, or at least to facilitate the callusing of the smoothly cut ends of the roots. We should lose no time in border renovation and raising and placing the roots in fresh soil. The roots inside the house will be of great service to the Vines next year, and we should not disturb them till next autumn, or until the outside border is occupied with active feeders from the lifted roots. Protect the border from drenching rains and melting snow in winter.

Woad (R. D. E.).—The Dyer’s Woad is *Isatis tinctoria*, from which a blue dye is obtained, with which the ancient Britons painted their persons, and in consequence of which the northern inhabitants of our island were called by the Romans, Picts, while those of the south were styled by the Celts, Britons, from the Celtic word *britho*, to paint. In Celtic it is called *glas*, signifying blue, and from this the name of Glastonbury is supposed to have arisen. As an article of commerce, Woad is now of much less value than it formerly was, when it formed a very important feature in English agriculture, its place having been supplied by indigo, which can be produced in much greater quantity and at a considerably cheaper rate. When the plant is ripe, which is known by its first leaves beginning to dry, all the leaves are cut off and laid in a heap to wither, in a place sheltered from the sun and rain, and are frequently turned over to make them heat equally. When properly fermented they are taken to a mill, similar to that used for crushing linseed, and there ground till reduced to a paste, which is afterwards formed into cakes of about a pound weight, and these are laid to dry in a covered place sheltered from sun and rain. In about a fortnight this paste has acquired sufficient consistence to be formed into small roundish lumps by means of little wooden moulds. As fast as they are moulded they are laid on wicker hurdles to dry, and when they have become hard they are in a condition for market. The dye obtained from Woad makes an excellent blue, and very lasting, but when it is used in the present day it is always in union with indigo, which adds considerably to the improvement of the colour. The leaves of Woad have a fleeting pungent odour, and an acrid durable taste. The plant is still cultivated to a small extent in the northern portion of the kingdom, notably about Boston.

Names of Fruits.—The names and addresses of senders of fruit to be named must in all cases be enclosed with the specimens, whether letters referring to the fruit are sent by post or not. The names are not necessarily required for publication, initials sufficing for that. Only six specimens can be named at once, and beyond that number cannot be preserved. (Fritton)—1, Bergamotte Esperen; 2, Ne Plns Meuris; 3, Beurré d’Aremberg; 4, Fondante de Noël; 5, Not known; 6, Felle. (Hogg & Wood).—1, Dutch Codlin; others not known. (H. C.).—1, Flemish Beauty; 2, Bergamotte Esperen; 3, Beurré Superfin. (T. Healey).—1, Dutch Mignonette; 2, Old Hawthornden; 3, Cornish Gilliflower; 4, Cox’s Orange Pippin; 5, Not known; 6, Carlisle Codlin. (J. M.).—1, Dunmore; 2, Beurré Defays; 3, Napoléon. (F. A. L.).—We had 10d. to pay for carriage of your box. (R. H.).—Louise Bonne of Jersey. (J. Udale).—1, Maréchal de Cour; 2, Easter Beurré; 3, Josephine de Malines; 4, Doyenné du Comice; 5, Autumn Bergamotte; 6, Not known. (J. P. Bartlett).—1, Adams’ Pearmain; 2, Not known; 3, Burr-Knot. (J. Moresby).—1, Gloria Mundi; 2, Flower of Kent; 3, Brabant Bellefleur; 4 and 5, Not known; 6, Easter Beurré. (J. Russell).—1, Glou Morceau; 2, Broompark; 3, Louise Bonne of Jersey; 4 and 5, Not known; 6, Madame Durieux. (W. H. P.).—Large Apple not known; small, Pearson’s Plate; Pear, Comte de Lamy. (Henry Heath).—1, Duchesse d’Angoulême; 2, Beurré Clairgeau; 3, Nouveau Poiteau; 4, Calebasse Grosse, or if it is melting and richly flavoured when ripe it may be Maréchal de Cour; 5, Not known.

Names of Plants.—We only undertake to name species of plants, not varieties that have originated from seed and termed florists’ flowers. Flowering specimens are necessary of flowering plants, and Fern fronds should bear spores. Specimens should arrive in a fresh state in firm boxes. Slightly damp moss or soft green leaves form the best packing, dry cotton wool the worst. Not more than six specimens can be named at once. (R. P. O.).—Aster Amellus var. *bessarabicus*. (Constant Reader).—We could not recognise the *Oncidium*, it was too small a scrap; and no “border flower” was enclosed in the box. (W. J. S.).—It is a variegated form of *Barbarea vulgaris*, a member of the Cruciferae family, and we do not remember having seen such a well-marked variety before. (J. J.).—*Asplenium caudatum*.

COVENT GARDEN MARKET.—OCTOBER 12TH.

ALL classes of goods in heavy supply, with business quiet, prices remaining the same.

		FRUIT.			
		d.	s. d.	s. d.	s. d.
Apples, ½ sieve .. .. .	1	6	to 3 6	Oranges, per 100 .. .. .	6 0 to 12 0
Nova Scotia and				Peaches, dozen .. .. .	2 6 6 0
Canada barrel	0	0	0 0	Pears, dozen .. .. .	1 0 1 6
Cherries, ½ sieve .. .. .	0	0	0 0	Pine Apples, English,	
Cobs, 100 lbs. .. .. .	45	0	50 0	per lb. .. .. .	1 6 0 0
Figs, dozen .. .. .	0	3	0 6	Plums, ½ sieve .. .. .	1 6 2 6
Grapes, per lb. .. .. .	0	6	2 6	St. Michael Pines, each	5 0 6 0
Lemons, case .. .. .	10	0	15 0	Strawberries, per lb. ..	0 0 0 0
Melon, each .. .. .	0	6	1 0		



VEGETABLES.

	s. d.	s. d.		s. d.	s. d.
Artichoke, dozen ..	1 0	2 0	Lettuce, dozen ..	0 9	to 0 0
Asparagus, bundle ..	0 0	0 0	Mushrooms, punnet ..	0 8	1 0
Beans, Kidney, per lb. ..	0 3	0 0	Mustard and Cress, punt.	0 2	0 6
Beet, Red, dozen ..	1 0	2 0	Onions, bunch ..	0 3	0 6
Broccoli, bundle ..	0 0	0 0	Parsley, dozen bunches ..	2 0	3 0
Brussels Sprouts, 3 sieve	0 0	0 0	Parsnips, dozen ..	1 0	0 0
Cabbage, dozen ..	1 6	0 0	Potatoes, per cwt. ..	4 0	5 0
Capisoums, per 100 ..	1 6	2 0	Kidney, per cwt.	4 0	0 0
Carrots, bunch ..	0 4	0 0	Rhubarb, bundle ..	0 2	0 0
Cauliflowers, dozen ..	3 0	4 0	Salsify, bundle ..	1 0	1 6
Celery, hundle ..	1 8	2 0	Scorzoner, bundle ..	1 6	0 0
Coleworts, doz. bunches ..	2 0	4 0	Seakale, basket ..	0 0	0 0
Cucumbers, each ..	0 4	0 6	Shallots, per lb. ..	0 3	0 0
Endive, dozen ..	1 0	2 0	Spinach, bushel ..	8 0	4 0
Herbs, bunch ..	0 2	0 0	Tomatoes, per lb. ..	0 4	0 6
Leeks, bunch ..	0 3	0 4	Turnips, bunch ..	0 4	0 6

PLANTS IN POTS.

	s. d.	s. d.		s. d.	s. d.
Aralia Sieboldi, dozen ..	6 0	to 12 0	Fuchsia, dozen ..	3 0	to 9 0
Arhor vita (golden), dozen ..	6 0	9 0	Geranium (Ivy), dozen ..	0 0	0 0
(ordinary), dozen ..	0 0	0 0	Tricolor, dozen ..	0 0	0 0
Asters, dozen pots ..	3 0	6 0	Gladiolus ..	0 0	0 0
Azalea, dozen ..	0 0	0 0	Hydrangea, dozen ..	9 0	12 0
Begonias, dozen ..	4 0	9 0	Lilies Valley, dozen ..	0 0	0 0
Capisoums, dozen ..	6 0	9 0	Lilium lancifolium, doz.	12 0	18 0
Chrysanthemums, dozen	4 0	12 0	longiflorum, doz.	0 0	0 0
Cineraria, dozen ..	0 0	0 0	Lobelia, dozen ..	0 0	0 0
Dracena terminalis, doz.	30 0	60 0	Marguerite Daisy, dozen	6 0	12 0
viridis, dozen ..	12 0	24 0	Mignonette, dozen ..	3 0	6 0
Erica, various, dozen ..	9 0	18 0	Musk, dozen ..	0 0	0 0
Eucynimus, in var., dozen	6 0	18 0	Myrtles, dozen ..	6 0	12 0
Evergreens, in var., dozen	6 0	24 0	Palms, in var., each ..	2 6	21 0
Ferns, in variety, dozen	4 0	18 0	Pelargoniums, dozen ..	0 0	0 0
Ficus elastica, each ..	1 8	7 0	scarlet, doz.	3 0	9 0
Foliage Plants, var., each	2 0	10 0	Spiraea, dozen ..	0 0	0 0

CUT FLOWERS.

	s. d.	s. d.		s. d.	s. d.
Abutilons, 12 bunches ..	2 0	to 4 0	Lilies, White, 12 bunches	0 0	to 0 0
Anemones, 12 bunches ..	0 0	0 0	Orange, 12 bunches	0 0	0 0
Arum Lilies, 12 blooms ..	3 0	6 0	Margnerites, 12 bunches	2 0	6 0
Asters, 12 bunches ..	2 0	8 0	Mignonette, 12 bunches	1 0	3 0
French, bunch ..	1 6	2 0	Myosotis, 12 bunches ..	1 6	3 0
Bouvardias, bunch ..	0 6	1 0	Narciss, 12 bunches ..	0 0	0 0
Camellias, blooms ..	3 0	6 0	White, English, bch.	0 0	0 0
Carnations, 12 blooms ..	1 0	2 0	Pansies, 12 bunches ..	0 0	0 0
12 bunches ..	4 0	6 0	Peas, Sweet, 12 bunches ..	1 6	3 0
Chrysanthemums, 12 bchs.	2 0	6 0	Pelargoniums, 12 trusses	0 9	1 0
12 blooms ..	1 0	6 0	scarlet, 12 trusses	0 3	0 6
Cornflower, 12 bunches ..	1 8	3 0	Poinsettia, 12 blooms ..	0 0	0 0
Dahlia, 12 bunches ..	2 0	4 0	Primula (single), bunch ..	0 0	0 0
Daisies, 12 bunches ..	2 0	4 0	(double), bunch ..	0 9	1 0
Eucharis, dozen ..	3 0	6 0	Polyanthus, 12 bunches ..	0 0	0 0
Gardenias, 12 blooms ..	2 0	5 0	Ranunculus, 12 bunches	0 0	0 0
Gladiolus, 12 sprays ..	1 0	1 6	Roses, 12 bunches ..	4 0	9 0
Hyacinths, Roman, 12			(indoor), dozen ..	0 9	1 0
sprays ..	0 0	0 0	Tea, dozen ..	1 6	3 0
Iris, 12 bunches ..	0 0	0 0	red dozen ..	0 0	0 0
Lapageria, white, 12			de Mois, 12 bunches	0 0	0 0
blooms ..	1 8	3 0	Stephanotis, 12 sprays ..	4 0	6 0
Lapageria, coloured, 12			Tropaeolum, 12 bunches	0 0	0 0
blooms ..	1 0	1 6	Tuberose, 12 blooms ..	0 6	1 0
Lilium longiflorum, 12			Tulips, dozen blooms ..	0 0	0 0
blooms ..	4 0	6 0	Violets, 12 bunches ..	1 0	1 6
Lilium lancifolium, 12			(French), bunch	1 0	1 3
blooms ..	1 8	3 0	(Parme), hunch	3 0	3 8

Turning now to practical results, we could point to examples of success and failure, such as a crop of Barley worth £12 to £13 an acre, and another which only sold for £1 an acre. We may be told that these are extreme cases marking the difference between crops on light and heavy land in a season of extraordinary drought, and it would be right enough in some respects. But the light land was undoubtedly in such low condition as to be incapable of affording sufficient sustenance to sustain a crop in full vigour even under a moderate degree of drought. We could quote plenty of examples of equally striking contrasts in root crops, which we know are owing to good and bad culture and not to drought. One of our bailiffs is justly proud of an eleven-acre field of Mangolds with such large, firm roots as to actually surpass the fine crop of last year; yet within 100 yards of it, upon a tenant's farm with land of the same staple, the Mangold crop is altogether inferior, simply through inferior cultivation. In point of fact the inferior crop should have been the better of the two, for it is in cool deep soil at the bottom of a valley.

The lesson which we wish to convey is that the crops on land under high cultivation are much less affected by unfavourable weather than those are in poor soil. A tenant whose rent was reduced to 14s. an acre has given notice of his intention to leave the farm next Michaelmas because he cannot make it answer. Now this man has two other farms, one of them his own freehold, the other hired upon another estate. Clearly he has too much land, and he is quite right in giving up some of it, if only his intention is to cultivate the remainder thoroughly. Judging from what we have seen of his practice, we are doubtful if he could make any land answer, for the whole of what he has is foul with weeds and low in fertility. It is precisely such men who allow their crops to suffer from poverty of soil and a second crop of weeds. They complain loudly of hard times; has not the landlord a right to complain of their negligence and slovenly practices? Undoubtedly the difficulties of the situation are great, but we certainly cannot yet think them insuperable. All farmers have had serious losses, but those who farmed well and were prudent in good times are with few exceptions still able to make their farms answer well enough to keep clear of debt. We have been told of failures among such good men and true, and we fear that in more than one instance it has been owing to ignorance.

For example, when a man has gone on year after year for a long time applying chemical manures to his land, and at length finds his crops fail, surely such failure may be attributed to ignorance. He has probably—most probably—used valuable fertilisers wastefully by rote, without striving to ascertain the condition of the soil, and so restrict his use of its requirements, or rather of those of the crops to be grown in it. Liberality in the application of manures is undoubtedly part and parcel of high farming, but it must be done intelligently and not in such haphazard fashion. When farmers generally come to regard the soil as a medium for conveying food to plants; when they set themselves in real earnest to understand the nature of the soil they cultivate; when they can combine practical and scientific knowledge so well as to know the best fertilisers and the due proportion requisite for the full development of each crop; then, indeed, shall we see high farming in its best aspect, and a farmer's knowledge of his calling will no longer be termed empirical. We do not pin our faith solely to the possession of such desirable knowledge, but rather desire to see it in combination with



MICHAELMAS.

SINCE writing our last paper much Michaelmas work of a special nature has been done, such as farm valuations, the giving tenants notice to leave farms, or receiving from them notice of their intention to do so. Not lightly do we part with a tenant now, but there are occasionally such instances of incapacity as to render it desirable in the mutual interest of tenant and landlord that the farm should be taken in hand, and the tenant relieved of an undertaking for which results show that he is quite incompetent. Prompt payment of rent may certainly now be taken as proof of capacity in a farmer, and glad are we to say that upon the estate under our care there are very few defaulters. Liberal reductions in rent have been made, the landlord thus doing his part "to meet the times;" the tenant's part is clearly to cultivate his land in the best way, so that by abundant crops of high quality he may continue to make his farm answer.

prompt, energetic, intelligent practice. We have in the past year seen remarkable results achieved by the use of farmyard manure, and by a thorough timely system of cultivation and cropping. We hope, nevertheless, to see eventually chemical manures given a more prominent place in agriculture, unless indeed the great sewage problem is solved, and we are able to obtain fertilisers for the soil from our large centres of population.

(To be continued.)

#### WORK ON THE HOME FARM.

The rain which fell so quickly after harvest has caused such a free strong growth upon pastures that we have now plenty of green food both for cows and sheep. Late-sown Turnips are growing freely, but we shall not have them singled, as at best this crop can only afford some green food for lambs in spring, and there can be no useful roots from growth so late in the year. On the whole we shall be tolerably well provided with roots. Mangolds are almost without exception a full crop, Swedes about two-thirds of a crop, but early white Turnips are a failure. This is all the more vexatious from the fact of really good fields of white Turnips being common enough, owing we believe to local showers of rain having fallen at a critical time upon such favoured spots. Rye, Rye Grass, Trifolium, and other autumn-sown green crops are a full plant, and there is now an ample provision of green food for next spring. Field Potatoes were taken up some weeks ago, as soon as signs of supertuberation were visible. Where attention has not been given to this matter the crop of late Potatoes will probably be spoilt. We know some large fields of Potatoes now with the haulm fresh and green and full of growth, showing clearly that a lateral growth both from haulm and tubers has been induced by heavy rain after drought. When the tubers are taken up it will be found that they are worthless, the legitimate crop of tubers having practically become seed which has produced an abortive crop of small worthless tubers.

Under present low prices for farm produce we are bound to curtail our labour expenses; while doing so enough men and horses must be kept going to cultivate the land really well, for it is altogether a mistake to let land become foul, and thus entail subsequent heavy losses in our crops. The practice of economy is most desirable and praiseworthy, but by all means let it be tempered with discretion. Drains should be seen to wherever there are faults or new ones are required. Ditches should also be scoured, and the mouths of all drains examined. Hard times have led to much negligence in the keeping of hedges and ditches in order, trim well-kept hedges being quite a thing of the past upon many farms. We regret to add that dilapidations in farm buildings are also as common now, and are an unmistakeable sign of poverty among landlords.

#### SEEDS AND ROOTS AT THE DAIRY SHOW.

Two well-known seed firms in Messrs. Sutton & Sons, Reading, and Messrs. Webb & Sons, Wordsley, Stourbridge, were represented by stands at the Dairy Show, held from October 6th to October 11th inclusive at the Agricultural Hall, Islington, London, N. The stands of both these firms were of an interesting character. That of Messrs. Suttons was found on the right immediately on entering the main hall of the building. At the front were large piles respectively of Sutton's Oxheart and Golden Tankard Mangel, both valuable kinds, specimens of Sutton's Champion Short Top Kohl Rabi, and of the Grass Bromus inermis, which is recommended for soiling, hay, or silage. At the sides of the stand were numerous specimens of natural Grasses and neat cases of Grass seeds, showing Mr. Martin Sutton's prescriptions for various soils. There were also models of roots. Messrs. Webb's stand was noteworthy for bunches of the firm's specially selected corn, such fine varieties as Golden Drop, Square Head, Hybrid Kinver, and Kinver Giant Wheats, with Challenge White and Prolific Black Tartarian Oats, and New Golden Grain and Kinver Chevalier Barleys being represented. There were also sample bags and sacks of Grass seeds and seed corns, collections of garden seeds, cases of manure, and specimen roots. Some samples of natural Grasses neatly labelled added to the effect of the stand. In other portions of the Show, garden produce grown from seeds supplied by the firms named, and Messrs. James Carter & Co., 237 and 238, High Holborn, London, W.C., was observable, also farm roots in competition for prizes offered by Messrs. Carter and Webb. Farm food and fertilisers were represented in the exhibits of Messrs. Jenson, manufacturers of the fish potash manure, and Spratt, makers of feeding cakes, &c.

#### REPORT OF THE SEED HARVEST OF 1887.

**Red Clover** (*Trifolium pratense perenne*).—There is a moderate crop of English seed of good average quality. Continental reports, including Italy, France, Germany, Denmark, and Russia, show some variation, but the latest information speaks of an average crop of well-ripened seed in these districts. The reports from America are not so satisfactory; and, as last year, the indications are that the supplies of sound seed will not be more than the home consumption will absorb. Considerable damage appears to have been done to the American crop by the dry weather, and the samples will not compare favourably with European grown seed. Taken all round, European Red Clover will be

good average quality, but, in consequence of the dry summer, the crops are somewhat lighter than usual.

**White Clover** (*Trifolium repens*).—The small quantity of this seed produced in England is of excellent quality, and from America our correspondent reports "very light crops." In Germany and Poland the crops are excellent both in quantity and quality, and prices for this article will be expected to rule moderate. Reports from France are not so satisfactory.

**Alsike Clover** (*Trifolium hybridum*).—Some very bright samples of English-grown seed have come into our hands, for which moderate prices are asked. From America the report is, "moderate crop, advancing in price," so that we need hardly expect to look to that district for supplies. On the other hand, reports from Germany, Poland, and Sweden are very satisfactory, so that fine European samples may be expected at reasonable prices.

**Trefoil** (*Medicago lupulina*).—The dry summer has had a bad effect upon the quantity of seed produced, both in England and on the Continent. Samples that have come forward are somewhat small, but good in colour.

**Lucerne** (*Medicago sativa*).—This crop is reported to be an average one.

**Timothy** (*Phleum pratense*).—Very unfavourable accounts are given of this crop both in the United States and Germany, and considerably higher prices are expected to rule than last year.

**Rye Grasses** (*Lolium perenne* and *italicum*).—Accounts of the English, Irish, and French crops state they are most abundant, and better in quality than for many years. As an instance of this, it may be mentioned that the natural weight for Perennial Rye Grass this year is 28 lbs., whereas for several years it has been about 24 lbs.

**Rap**.—Is a fair average crop, harvested in excellent condition, and the samples are very bright and black.

**Mustard**.—Fair average crop.

**Swede and Turnips**.—The burning summer secured the samples "shot dry," but the produce is exceedingly short in many varieties.

**NATURAL GRASSES**.—*Anthoxanthum odoratum* (Sweet Vernal).—There is a very fair crop of this Grass, showing an exceptionally high standard of germination. *Agrostis stolonifera* (Fiorin).—This is a good average crop, both in Germany and America, but, as this Grass is very subject to ergot, samples free from the impurity command good prices. *Alopecurus pratensis* (Meadow Foxtail).—This is again one of the shortest harvests of the Natural Grasses, and samples are not numerous that will give the average germination for the past two or three years. *Cynosurus cristatus* (Crested Dogstail).—Is a good average crop in England, Ireland, Holland, and Germany; brighter in colour and higher in germination than it has been for some previous years. *Dactylis glomerata* (Cocksfoot).—Is only a moderate crop. Reports from New Zealand have not been satisfactory. European samples have a high standard of vitality, and command higher values than they did this time last year. *Festuca tenuifolia* (Fine-leaved Fescue).—This crop is usually very light, but as its principal use is for the formation of lawns and pleasure grounds it is not an important factor in the supply. *Festuca duriuscula* (Hard Fescue).—Is again a good average crop, and seed of high germination. *Festuca pratensis* (Meadow Fescue).—Is perhaps the most satisfactory of any Grass crop of the year, with germination exceedingly high, and many of the samples absolutely pure and free from objectionable features. *Festuca elatior* (Tall Fescue).—This Grass is more plentiful than in previous years; but as the supply is still under the demand, the best samples command high prices. *Poa trivialis* and *memoralis* (Rough Stalk Meadow Grass and Wood Meadow Grass).—Are good average crops, fine in quality. *Poa pratensis* (Smooth Stalk Meadow Grass).—Reports from Europe and America speak of a fair average crop, but many American samples are very deficient in vitality.—JAMES CARTER & Co., 237 and 238, High Holborn, London.

#### METEOROLOGICAL OBSERVATIONS.

CAMDEN SQUARE, LONDON.

Lat. 51° 33' 40" N.; Long. 0° 8' 0" W.; Altitude, 111 feet.

DATE.	9 A.M.					IN THE DAY.				Rain	
	Barometer at 52° and Sea Level.	Hygrometer.		Direction of Wind.	Temp. of soil at 1 foot.	Shade Temperature.		Radiation Temperature.			
		Dry.	Wet.			Max.	Min.	In sun.	On grass.		
1887.											
October.											
Sunday .....	2	30.307	51.7	49.3	N. N.	52.2	57.6	45.2	75.9	39.9	—
Monday .....	3	30.401	53.1	49.1	N. N.	52.3	57.7	47.8	70.2	42.4	—
Tuesday .....	4	30.382	52.6	47.9	N. N.	52.6	59.1	49.3	72.7	47.6	—
Wednesday .....	5	30.337	52.2	47.8	N. E.	52.8	54.6	50.0	69.2	48.3	—
Thursday .....	6	30.177	50.9	46.8	N. N.	52.8	57.3	48.4	91.4	47.4	—
Friday .....	7	30.085	50.4	47.6	N. W.	53.0	61.1	48.2	102.3	46.9	—
Saturday .....	8	29.937	52.1	49.0	S. W.	53.2	63.6	47.6	101.9	44.4	—
		30.228	51.9	48.2		52.7	58.7	43.1	82.4	45.3	—

#### REMARKS.

2nd.—Cloudy all day.  
3rd.—Dull and calm.  
4th.—Overcast all day, and almost without wind.  
5th.—Overcast and calm all day.  
6th.—Dull early, fine after 11 A.M.  
7th.—Fine, and at times bright.  
8th.—Fine, bright, and pleasant.  
Temperature much the same as in the previous week, but the nights warmer; generally calm and cloudy; no rain.—G. J. SYMONS.



## COMING EVENTS

20	TH	Inner Temple Chrysanthemum Show opens.
21	F	
22	S	Finchbury Park Chrysanthemum Show opens.
23	SUN	20TH SUNDAY AFTER TRINITY.
24	M	
25	TU	Royal Horticultural Society—Fruit and Floral Committees at 11 A.M.
26	W	

### THE ROSE SEASON OF 1887.

**I**HAVE for several years past recorded in the pages of the Journal my review of the Rose season, and expressed opinions resting on a rather varied experience in all parts of the kingdom as to its character; and in the years that I have done so I never had to record so terribly a disappointing one. The question is often put, When are we to have seasons for

Roses such as we used to have? It is no boyish regret of past days; no foolish praise of the better times which have preceded us, that leads to the question being asked. We, of course, have to look at things from our own point of view, for as a matter of fact for the general lover of the country and the bright summer time, we have not had for many years a more enjoyable summer; and yet it has been, as I believe, about the worst season for the Rose-grower I ever recollect, not even the terribly wet season of 1879 was more disastrous.

I have had during the past season fuller opportunities for giving my opinion than in the two previous years. Once more have I crossed the border, and at our National Show in Edinburgh, and at Helensburgh, seen what is the state of Rose culture and Rose showing in Scotland; while in England I have had the opportunity of judging at Canterbury, Sutton, Hitchin, Farningham in the Home Counties; at Christleton, Wirral, Manchester, and New Brighton in the North; and later on at Taunton and Bath in the West; and this with my experience at the National ought to give me a good foundation on which to form a comprehensive judgment. But, besides this, I have been enabled to visit many private Rose gardens, and some, too, of the growers for sale, and to gather from these sources facts and opinions which have helped me to form my conclusions.

No better adjective occurs to me to describe the Rose season of 1887 than disappointing. We had hoped much: the Rose-grower had patiently waited for the time when all his care and trouble should be rewarded; things seemed to be favourable, foliage was healthy, green fly had not made its appearance, buds were well developed, and if only a propitious time were given at the end of June and beginning of July there were strong hopes that a very fine Rose season would follow. But, alas! this was not to be. In the early part of June the drought set in. This was bad enough, but as the month drew to a close the temperature mounted up; while in the first fortnight of July, when the Rose shows mostly take place, the thermometer was rarely below 80° in the daytime, sometimes getting nearer to 90°, with a high night temperature also. What this was in its results on Roses it requires no witch to tell. It pro-

duced as a first result undersize throughout; it also produced in high-coloured Roses a faintness of colouring, and in some cases complete disfiguring; and the only flowers that really showed to any advantage were those light-coloured varieties to whom a dry sunshiny time is life itself. It thus happened that at all the Rose shows flowers had a tired and used-up look, and it was only where flowers could be cut close at hand and removed but a short distance to the place of exhibition, that one saw them at all in their proper condition. Thus Mr. Lindsell at Hitchin, Mr. Hall at Wirral, and one or two others, made one much desire that all could exhibit under the same conditions. But it must not be supposed from this that Roses were not shown in fair condition, for they were, and the marvel to me was that after such a night for travelling as the night preceding the Edinburgh Exhibition, Roses could be produced so well worth looking at; but they were not All, not merely in matter of size, for this is a point on which I fear Rose-growers are going astray, but in that freshness and brilliancy of colour which go to form so much of the charm of the Rose. And I think that most people who know anything of the difficulties of the season were ready to say, as they stood abreast of some of these stands, "It is wonderful how they do it, but they do it."

And yet, notwithstanding all these disheartening circumstances, one can see no abatement in the zeal of Rose-growers, for although some societies have committed the happy despatch yet there are others springing up. Cardiff, which had maintained under many disadvantages an uphill fight, has at last succumbed. Cray Valley, too, commencing well as it did, has had but a short life; let us hope it was a merry one. Henfield, with even a shorter span of life, has very soon died of inanition. Moreton has gone up like a skyrocket, but I am afraid has come down like the stick thereof. Leek has revived, and I hear of a very successful one near Derby; but I fancy that there are not so many to take the places of those that have fallen out, while in some few there appears a slackening of interest.

The National Rose Society, of course, claims the first place in the affections and interest of all real lovers of the flower, and this year has been a notable one in its history. For the first time it has crossed the border, and nothing could exceed the loyalty and kindness with which it was welcomed in Edinburgh. The Lord Provost and some of the City dignitaries attended the Show, and welcomed the Committee and exhibitors, and such a show of Roses was given to the Scotch folk as they have not before seen. But I confess, for reasons which I have before given, that I do not anticipate a renewal of this, for the simple reason that there is in Scotland a complete absence of what we know as the amateur class. Such men as Messrs. Lindsell, Pemberton, Hall, Girdlestone, Grant, and others are utterly unknown there. An amateur with a couple of hundred Rose trees is a prodigy, and when our friend Mr. Gray started his Rose-growing at Dunkeld he was considered "aye daft." This was painfully apparent in the district prizes at Edinburgh—a more sorry lot it is impossible to conceive. I do not think that this arises from the soil or climate. There are districts in Scotland where both are as favourable to the culture of the Rose as some of the most favoured parts of England. The exhibits of Messrs. Smith of Stranraer, and Cocker & Son of Aberdeen prove this, but it is just simply that the class is not there. The same prevails to a great extent in France, and it may be



perhaps adduced as one of the results of the close intimacy in former days between the two countries!

Of the Exhibition at South Kensington one has to write with bated breath; in extent it probably was equal to any that have preceded it, although as I have said the season prevented the quality of the flowers from being up to the mark. To this exception may perhaps be made in the case of the Teas, of which both in extent and quality there was a most wonderful exhibition; indeed, all through the country this class has come wonderfully to the front; and although in the north they cannot be grown out of doors as in the other parts of the kingdom, yet there they are cultivated extensively and successfully under glass. But oh! the dreariness, the desolate character of the place—no band provided, not a single member of the Council of the Royal Horticultural Society present to say officially good speed to the Society. The coldness of the reception might have somewhat mitigated the heat of the day, were it not so depressing, and when only the next week the Society was so cordially welcomed at Edinburgh, it was useless to avoid drawing unfavourable contrasts. What wonder that one heard on many sides, "It is the last time I will show here." And it is a matter of deep regret, I am sure, to all who value the advance of horticulture, to see the utter want of appreciation that there seems to be of what may best advance those interests.

The character of the season has had some remarkable effects in the style of the showing. The greater coolness of the north helped the northern growers, but I do not think that anyone was prepared for the exceptional success which awaited the two striplings, the Messrs. Harkness of Bdale (and I may say in passing, that if all knew their history as I do, they would feel glad that such success has awaited them). They have the following record to give. They commenced with the National at South Kensington, and from that to the 26th July they showed thirty-five stands, obtaining twenty-two firsts, eight seconds, and five thirds, winning all the prizes for seventy-two's offered by the National and its affiliated Societies, besides the two challenge trophies of the National Rose Society; they have shown at Bath, Birmingham, Hereford, Wirral, North Lonsdale, Chesterfield, Derby, and Hull.

Coming to the amateurs, the most successful records have been those of Mr. Grant of Ledbury, and Mr. T. B. Hall of Larkwood, Rockferry. The former began at Moreton-in-the-Marsh on the 29th June, and from that on, showed at South Kensington, Crystal Palace, Oxford, Malvern, Birmingham, Hereford, Wirral, and Christleton. He gained altogether forty-one first prizes and a special, twelve seconds, twelve thirds, and two fourths, two silver medals National Rose Society, and one gold medal, besides the challenge trophy of the National Rose Society. Mr. Hall, whose coming to the front I have long felt was a matter of certainty, although he suffers something with regard to the earlier shows, commenced at South Kensington, and ending at Sefton Park, Liverpool, on July 28th, when his Roses were at their best, the total results being twenty-nine firsts, eleven seconds, and seven thirds, with the Jubilee trophy at Edinburgh, two gold, two silver, and one bronze medal. These are both highly honourable records, and show with what enthusiasm many of our amateurs enter into Rose-growing. I have mentioned twice the Jubilee challenge trophy. This arose, as its name implies, out of the celebration of Her Majesty's Jubilee. The National Rose Society desired to do something to mark it in connection

with the national flower, and it had been long felt that the midland and northern growers were handicapped as far as the southern trophy was concerned, and hence, when the idea was started and responded to, it was determined to appropriate the money subscribed to two trophies, to be competed for at the Provincial Show, one by nurserymen, the other by amateurs; and then, as if in irony of our wisdom, a northern grower comes down and takes the southern nurserymen's trophy, just as Mr. Whitwell of Darlington once took the amateurs'.

There is one subject in connection with the past season which we cannot omit—the production of new Roses, and the behaviour of those not absolutely new, whose position we are anxious to ascertain. Of really new Roses there has not been a plethora, but there are two, of which I have already written, which are, I believe, destined to take a high place—Earl of Dufferin, the beautiful bright crimson Rose raised by Messrs. Alex. Dickson & Sons of Newtonards in the Co. Down, Ireland, and Sir Rowland Hill, the dark claret Rose originated by Messrs. Mack & Son of Catterick Bridge, Darlington. As good wine needs no bush, so a Rose that has gained the first prize for the best of any one Rose at a National Show, and another which has gained the Society's gold medal, need no further recommendation.

Of Roses not quite absolutely new Her Majesty claims the first mention. Opinions differ, and I am myself somewhat prejudiced against large Roses. I confess that Roses of the size of Paul Neyron, Ulrich Brunner, Etienne Levet, Antoine Mouton, &c., are not those which I consider the type of perfection, and therefore, when Her Majesty's size is applauded, I cannot chime in with it. I can only be disloyal enough to mutter "coarse," and to say that if you want to show it in anything like decent form, you must treat it like Paul Neyron, and either starve it or cut it from a weakly shoot or perhaps bud it on the Briar. Clara Cochet has been, so far, disappointing, being too thin, but this may have been the effect of the season. Grand Mogul, which is a promising Rose, has had a hard time of it, and was but little seen. Alphonse Soupert has proved itself a valuable Rose. To these may be added Victor Hugo and Prosper Langier. Amongst Tea Roses, as with Hybrid Perpetuals, little has been seen of those of last autumn, but Comtesse de Frigneuse is no doubt an acquisition, being of a bright canary yellow, with large and full flowers, and of good growth, while Souvenir de Gabrielle Drevet is a fine Rose of the Souvenir d'Elise style, salmon white, with deep rose in the centre, changing from coppery yellow to clear salmon. The Bride, too, is no doubt a great acquisition, a white Catherine Mermet. What more can we want? It is very beautiful, and will, no doubt, be a general favourite both for market and exhibition purposes. Ye Primrose Dame and Viscountess Folkestone are Hybrid Teas, and are pretty Roses.

It now only remains for me to do what I hope I have, however inadequately, done before, express my sincere thanks to those many, many, kind friends by whom I have been so cordially welcomed while "on circuit," and to thank others who have reposed confidence in me in asking for my recommendation when I could not judge myself. The courtesy and kindness with which I have been everywhere welcomed makes me more than ever feel what "good fellows" Rose-growers are; while I cannot but express my deep thankfulness that, although my engagements have been so numerous and at such distances from one another, yet I have been enabled to fulfil them all,

and for a septuagenarian this ought to be, as it is to me, a deep cause of gratitude.—D., *Deal*.

## IMPROVEMENT OF SOILS.

### DIGGING—MANURE.

THE present is a suitable time to review the best methods of cultivating soils in order that the largest amount of produce may be secured with the least outlay of labour. Depth of fertile soils is considered, and rightly considered, the test for gauging the value of any particular piece of ground. No doubt there are other conditions, but anyone wishful of renting a piece of ground would be guided to a greater extent by the depth or shallowness of the soil than by any other or perhaps most of the other conditions together. I have several times proved that the addition of new material to the surface of shallow soils has improved the crops to an extent that would hardly be believed by those who have had no experience of the good effects of such a procedure. Where plenty of waste material is to be had there would be no cheaper method of soil improvement than that of adding it to the depth of 6 inches to a foot on shallow soils. Provided the material is open in texture—and that is a necessity—the benefit is immediate and continuous.

The ordinary methods of soil improvement by digging or trenching are much slower in effecting improvement. They are, however, very necessary, and of the very first importance when rightly performed. Turning up soil to the influences of the weather means that a certain portion will be completely pulverised, and thereby rendered in the best condition for the roots of plants to ramify and increase and secure food with rapidity. In the case of very heavy soils the importance of keen frosts and drying winds as a means of securing a good seed bed can hardly be over-estimated. The similarity in effect of strong heat and extreme cold is well exemplified in cases where surface soils are pulverised by burning, though generally the good effects following are not so much attributed to this complete breaking up of the soil into minute particles, as to the setting free of certain food constituents which previously were unavailable. That is so, of course, but it may be taken that the main benefit in cases of soil exposure to extreme heat and extreme cold is due to the old-fashioned reason of the soil having been rendered of a "good working condition;" but the improvement mechanically is also of importance, and here it may be pointed out that turning soil, either one, two, or three spits deep, as the case may be, gives no clear intimation of the benefits of the process. The object of all cultivation is the breaking up of soil, and the better this is performed just so much the greater will be the improvement following; hence the necessity of thoroughly breaking all clods and lumps of soil which are too deep for weather influences to reach, and well executed work will not consist only of the turning soil to the surface, but also of a rough-and-ready pulverisation of the deeper soil in the course of working. Some gardeners who thoroughly recognise the importance of this have discarded spades and employ forks for turning ground. I think the work is more rapidly performed by means of spade culture, but it is more necessary to see that the workmen are duly paying attention to the furrows than if forks are used. As to the question of how deep soil should be cultivated, that of course depends on the kind of soil. If the subsoil be so bad as to admit of no improvement or amelioration, then it would be waste of time to try to improve it by any other means than increasing the depth of fertile soil from the surface. All the advocates of deep cultivation contend that shallow cultivation cannot yield the same good returns that deeper soils will; therefore, the point each individual has to consider is the best means of deepening the soil he has to deal with. If by subsoiling, then certainly do so. If too shallow naturally for that, then add to the surface as pointed out at the beginning of this paper.

As to the best time to turn up soil, I think it cannot be done too early in autumn. Soil either dug or trenched in October invariably turns out in the best condition in spring. Winter-dug ground is occasionally damaged by snow, and when left till spring the ground misses the good effect of frost, &c. At the same time, if ground is thoroughly well worked, either digging or trenching may be performed at any time from spring to late autumn, and if planting or sowing follows directly, the good effect of the process will be very noticeable. The time to apply manure and the method of application is also a moot point. For my own part I allow myself a pretty wide latitude. If I think it will pay to mix manure in a stratum of soil 18 inches or 2 feet deep, I do so. If, on the contrary, the manure would be likely to be more quickly effective applied just under the surface, then that is done. To particularise, I would not, as a rule, place dung at the bottom of a deep trench. Cases occur, however, when it is necessary to do so.

I find that Globe Artichokes, for instance, cannot be well grown unless on deeply manured soil. The Hollyhock, as a flower, has the same liking, therefore in preparing ground for these and others of a like nature, the dung is put in deeply. But in preparing a quarter for Cauliflowers, Cabbages, Savoys, &c., plants which require to make very rapid progress from the first, and which, as a rule, do not go far in search of food, we do not bury the dung deeply. In many cases we put horse or cow manure just a few inches beneath the surface of the soil. This applies to anything which is to remain only a short time on the ground—such, for instance, as seedlings, Spinach, or pricked out flowers, &c. The time of application also varies, but as a rule good dung should be dug in just before the crop is sown or planted. That, of course, cannot always be followed out, but it is a good principle to work by. Such crops as Potatoes, Strawberries, Peas and Beans, Broccoli and Brussels Sprouts, are most satisfactory when grown on soil which had been manured for a previous crop.

Then it may be asked, What is "good" manure? Very many do not think it is entitled to that adjective until it has become old and decayed. Unfortunately the best of its manurial properties have then disappeared. There are cases where partially decayed manure is advantageous, as for Celery trenches, but generally the fresher dung is on application, so long as it is not quite "green," the better is it for crops.

Though I should not care to follow any artificial method of cropping ground such as is laid down for guidance in gardening works, still it is necessary that gardeners should work their ground systematically. It is not only good for the ground itself, but the land is more cheaply wrought and yields more profusely. As examples, Potatoes will be found to succeed excellently after late Cauliflowers and Broccoli. The ground, if well manured or mulched for these, will be quite rich enough for Potatoes. The texture of the soil will be open and the crop certain to be good. In like manner early Kidney Potatoes do very well after Celery, merely pointing over the ground. Peas and Beans also do well after Cauliflowers and spring Broccolis, but these should be sown in trenches. The space between, if not too hard, will grow fine Lettuces, Turnips, &c. After Potatoes, Spinach, Winter Onions, Lettuce, Endive, Scotch Kale, &c., do splendidly. The ground requires no turning up, and if help is needed to bring on crops in spring a slight dressing of sulphate of ammonia will put that all right. Brussels Sprouts do very well after Seakale or other crops that have been on enriched soil. No digging is required, and Sprouts are always best from rather poor soil. Where there is much pressure for space it will sometimes be found convenient to sow annuals or plant flowers in certain likely portions of the vegetable quarters. In such the flowers succeed splendidly.—B.

## THE DRY WEATHER AND SPINACH GROWING.

ONE very important lesson taught us by the excessively dry weather of the past summer was to make extra provision for the storage of water, either by constructing new tanks or enlarging those already made. It was well nigh a water famine, for no rain fell from the last week in May until the 16th of August. The soil of the garden being a chalky loam, very shallow, and resting on solid chalk, it will be inferred that all kinds of vegetables suffered severely, but as regards Spinach it was very difficult indeed to get a dish. The ordinary way of growing it was a failure, for as soon as it was up and began to form leaves the plants ran to seed. The only way I could obtain any was by digging trenches a spade's width and depth, then putting in manure, covered with soil, sowing the seed upon it, and by keeping the plants watered I managed to get a partial crop. The hot weather had its effect, as it soon ran to seed, and but for a sort of perpetual Spinach grown here I could not have kept up a supply. This plant was new to me. I therefore send you a flower stem, also a few leaves, and will thank you to enlighten me upon it. My employer calls it "Sea Spinach," and there is a salty flavour in the leaves. He prefers it to any other, as my orders are to send it to table as often as I can get it. The plants were growing the whole of the dry weather, and proved so useful to me that I think it ought to be better known to be more cultivated. I therefore give my system of culture, which is very simple.

Select a piece of ground in the open with a fair depth of good garden soil, dig it deeply—that is, to the full depth of the spade, adding plenty of manure, well bury it so that there may be 6 inches of soil over. Level the surface by raking it down, then set out the rows, which should be 2 feet 6 inches apart, and the plants in the row 18 inches. This distance appears great, yet if the plants do well the bed should last three years or more, and before that time they will meet each other. When planting use a trowel or small fork instead of a dibble, and set the plants in deep enough to make firm and water them. The after treatment is mainly to

keep the ground clean by hoeing, and keep all flower stems picked off, the plants will then make numerous shoots close to the soil and establish themselves well enough to begin. Pick the leaves at the end of the season. In the following spring, after hoeing between the plants, place on a thin coat of manure. The leaves are much smaller than the ordinary Spinach, but much more numerous, and if in gathering the largest are taken, the others will come on in regular succession. The plants can either be increased by division or seed, but the former is much the better and most expeditious way. The month of March or beginning of April is a fit time to make a plantation, and it should be removed about every third year.—THOMAS RECORD.

[The plant is *Beta maritima*, and the experience of our correspondent is both interesting and useful.]



#### ORCHIDS AT MYLNHURST, ECCLESALL, SHEFFIELD.

THE owner and occupier of this fine place, Major Blake, J.P., is a great admirer of Orchids, and is fast forming a valuable and interesting collection, containing many choice and rare specimens, amongst which are two plants now flowering of the rare and beautiful *Catasetum Bungei*. These plants were purchased in the early summer from Messrs. Stevens as dry freshly imported pieces. One of the two has matured a very strong growth equal in size of pseudo-bulb to those the plant made in its native home, and which produced one spike carrying thirteen flowers. The other plant has made two new growths not quite so strong, one of which has two flower spikes and six flowers, the other two flowers. The flowers are very beautiful and singularly attractive, with the large shell-like lip, pearly whiteness of colour, and delicious perfume. The plant appears to be very free, and will certainly become popular as it becomes cheaper and more plentiful. Of *Cattleya guttata* Leopoldi, a fine var., obtained as dry imported piece in spring, is now flowering with two flower spikes, one spike having six flowers. *Lælia Perrini*, obtained at the same time and in the same condition, is also flowering with two spikes. A plant of *Lælia purpurata*, obtained dry at the same time with twenty old pseudo-bulbs, has thrown out ten good leading growths. Four plants of *Cypripedium insigne* in 9½-inch pots are very fine, having extra large foliage and an average of twenty fine flowers to each plant. *Cypripedium Harrisianum*, a smaller plant, has twelve flowers; *C. Spicerianum*, four flowers; *Lælia autumnalis*, three very strong flower spikes; *Lælia albida*, a plant in a 12-inch basket, has twelve strong flower spikes; *Odontoglossum Uro-Skinneri*, just getting past its best, has had twenty-one flowers on one spike.

Some fine *Oncidiums* are flowering. *O. Lanceanum* has three spikes and eighteen flowers; *O. crispum*, imported dry in spring, is now carrying a spike of twenty flowers; *O. tigrinum* has an immensely strong spike; *O. incurvum*, very pretty, with seven flower spikes; *O. bicallousum*, a very effective and beautiful variety, with bright golden yellow lip and orange yellow sepals and petals, very crisp curly-looking flowers, 2 inches across, and a rich scent resembling Violets. Two large plants of *Maxillaria grandiflora* are laden with flowers, about twenty fully expanded on each.

*Lycaste Skinneri delicatissima* is a very choice form of this old favourite; a plant here with two leads is carrying five flowers. A number of good varieties of *Odontoglossum Alexandræ* are flowering, also *Pleione Lagenaria*, *Dendrobium Deari*, *Brassavola Martiana*, and numerous other good plants. Especially noticeable is the free-flowering character of the plants throughout the collection, and which we think due in no small measure to the extremely light and airy houses in which they are growing. Mr. Herriott, the gardener, has also been remarkably successful in establishing newly imported plants, as many of those I have above referred to testify.—W. K. W.

#### LONG DROUGHT AND ITS EFFECTS.

UNDER the above heading (page 300) Mr. W. Iggulden treats the readers of the Journal to an interesting if not amusing recitation of his views respecting the manner in which a kitchen garden should be cultivated. If our friend is satisfied with the results secured at Marston by following the method of procedure which he advocates, well and good; but he should not indiscriminately condemn that followed by all good kitchen gardeners who have the means at command, including the thirty exhibitors referred to, and who have at least given ample proof

at most of the leading exhibitions of vegetables of the soundness of the practice which he would have your readers believe is faulty.

Indeed, the magician must have waved his wand over the kitchen-garden at Marston this year, for Mr. Iggulden informs us that "Lettuces, Kidney Beans, and Peas have done best on the ridges between the Celery trenches during the past summer," remarking that the Lettuces had "no manure and little else but hard soil to root in, and yet they grew to a good size and did not bolt more quickly than usual." Before I touch farther on this subject I should like to ask how far this statement is to be accepted as evidence in favour of his plea for surface cultivation. Again, we are told in the same and concluding paragraph of what may be termed Mr. Iggulden's "Jubilee contribution" to kitchen gardeners at large, that "our latest Peas were gathered from rows growing on unmanured and firm ground, and which but for the birds would have continued to yield" (?). The soil at Marston must indeed be remarkably fertile and moist, for rows of late Peas sown presumably the first or second week in June in "unmanured and firm ground" during such weather as we experienced throughout the past summer months to have yielded one creditable gathering of Peas, to say nothing about continuing to yield "but for the birds." The conclusions which all practical kitchen gardeners will arrive at after reading the above statements is that far better and heavier crops would have been secured had the ground been deeply dug and liberally manured before being cropped. Does Mr. Iggulden mean to say that his remarkably heavy crop of old Ashleaf Potatoes which were lifted from a piece of undug unmanured ground, would not have been still heavier and better in quality had the conditions under which they were planted been the reverse of those indicated? Potatoes we know, though smaller, are always of better quality during a dry summer. Although one would have thought that Potatoes which were "simply laid on the hard surface and moulded over" with the burning surface soil would, instead of producing "a remarkably heavy crop of rather ugly tubers," have been slowly "roasted" during the past tropical summer.

Your correspondent says in substance that the practice of successful exhibitors of vegetables at the leading metropolitan and provincial shows should not be accepted as evidence in the question of "deep against surface" culture in the kitchen garden. Why not? It is the opinion and practice of men who have and do still distinguish themselves in the culture of fruits, plants, and vegetables, which are especially worthy of the consideration and emulation of all gardeners who not only wish to excel in culture, but who also wish to arrive at a satisfactory conclusion of any question arising out of the cultural details involved in those subjects. Mr. Iggulden says, "What about the amount of watering, &c., expended over exhibition vegetables?" What about it, indeed! Does not your clever correspondent and every other practical gardener well know that any "amount of watering" with liquid manure and otherwise at the roots of vegetables, fruit trees, and plants with the view of securing the most satisfactory results from the ground cannot be looked upon otherwise than the right thing to do, whether the produce be required for exhibition purposes or for home use? He is quite right in saying that he "may be blamed for calling prize vegetables at a first-class exhibition coarse," because, as a rule, the produce in prizewinning collections and single dishes of vegetables combine with size quality. Your correspondent must know very well that only produce of first-rate quality will find a place in the prize list at really good shows; and also he must know that large specimens of Carrots, Cauliflower, &c., may be obtained without being necessarily coarse, although large specimens of kitchen garden produce, as a rule, are sent to and cooked for the servants' hall, while the medium-sized ones are prepared for the dining-room table. However, I would remind our advocate of "surface tickling" that a large well-grown Carrot, Parsnip, Cauliflower, or Cabbage is not necessarily tough and wanting in flavour, neither are small specimens of the kinds indicated which have been grown in 6 inches or 9 inches deep of loose soil resting on a hard pan of "undisturbed" fertile soil necessarily crisp and full of flavour. When I tell Mr. Iggulden that an experienced man (French) cook with five assistants presides over the kitchen department of the establishment which it is my privilege and duty to supply with all kinds of garden produce, he will, I think, readily admit that I am in a position to know what the likes and dislikes of good cooks are in the way of vegetables.

Our garden soil is light and rests on a gravelly subsoil, and is from 2 to 3 feet deep. We trench a portion of our kitchen garden to that depth annually, burying therein three good layers of stable dung as the trenching is proceeded with, so that every six or seven years the whole of the garden is trenched, and before the ground is cropped it receives a good surface dressing of wood ashes. In the trenched ground we plant our autumn-raised Cauliflowers towards the end of February and at intervals during the first three weeks in March between rows of Carter's Telephone, Telegraph, Pride of the Market, Stratagem, and other mid-season Peas in drills about 3 inches deep and 2 feet apart, and at the same distance in the row. As soon as the Peas appear a couple of inches above ground they have a little soil drawn up to them on each side and are then staked in the ordinary way. This done, a good mulching of dung to the thickness of 5 or 6 inches and about 9 inches wide is laid on each side the ranks of Peas. All our previous and subsequent sowings and plantings (for we annually transplant a good number of Peas out of pots when about 6 inches high) are treated in a like manner as regards the mulching of the rows. It may not be without interest to Mr. Iggulden to know that from Peas treated as indicated we gathered ample supplies to meet the requirements of our establishment during the past summer and up to the middle of last month, and we have now



(October 10th) a row of Webb's Chancellor well furnished with large partly filled pods, and from which, should the weather continue as it had been the week or ten days, we shall yet hope to gather a good dish or two of Peas.

I may add that our rows of Peas had several good waterings at the roots during their growing period. I may also remind Mr. Iggulden that Peas and Cauliflowers could be grown satisfactorily enough in America during the summer months, provided they were kept moist enough at the roots. It was the insufficiency of moisture that caused so many failures of these crops this season, the failures being especially noticeable in light and "shallow-cultured" soils. Those who attended the Shrewsbury Show in the middle of last August and that at Cheltenham a month later could not help being impressed with the grand samples of kitchen garden produce so admirably staged at both shows. The soil must be very rich, stiff, and retentive of moisture in those districts to yield such praiseworthy specimens during a season like the last. These facts prove conclusively enough that where soil is rich and deep, and the various kinds of kitchen garden crops were kept sufficiently moist at the roots, the best possible results have been secured during the past intensely hot summer. Such, at any rate, is the experience of.—A GROWER AND EXHIBITOR.

I AM much pleased with "A Thinker's" reply to Mr. Iggulden respecting Potatoes and Lettuce on Celery ridges. Mr. Iggulden has several times before placed himself in the same false position. Undoubtedly, "Thinker" is right in his statement that the Lettuce and Potatoes were better because of their having deeper, warmer, richer, rooting medium by the fact of having two surface soils in the space of one; or, in other words, double the quantity of soil of equal fertility in a given superficial area.

I commenced a system of deep cultivation by bastard-trenching in 1873, and I have continued that system to this day, and shall do so in the future. Each year strengthens my faith in the system—heavier crops (about double) of vegetables and fruit, and each of higher quality, being produced from the same area of ground. Any tendency to coarseness, as in the case of Beet, is obviated by leaving the plants closer together than is usually the case; we thus get double the quantity of juicy and tender roots.

When I came here my employer complained to me about the hardness and stringiness of the Beetroot they had been having all that winter and the previous winter. Thinking that, perhaps, the Beetroot was not so bad as she stated, I tried them for myself, and found them uneatable; I also came to the conclusion that the sole cause of it was that they had been grown on poor shallow soil. I adopted my usual method of culture, with the result that there has not been a word of complaint about the Beetroot. We have had a constant supply of Cauliflowers and Peas up to the present date. Cauliflowers that were on untrenched land nearly all went "blind" in the summer. Our supply was kept up by those planted on a border that was bastard-trenched last winter 2 feet deep. No water was given them except in spring shortly after being planted. I intend to bastard-trench every available square yard of this kitchen garden, all being well.—A NOBLEMAN'S GARDENER.

ALLOW me to explain that it was "A Northern Gardener" who detailed his exploits in the way of growing "Beet for the pigs," large Celery, big Onions, and other vegetables that the cook would invariably reduce to a serviceable size. I do not admire "A Thinker's" style of conducting a discussion, and the first paragraph of his last epistle was anything but kind. Perhaps he was anxious to convey a delicate compliment, but why do it at my expense?—W. IGGULDEN.

### MINA LOBATA.

OCCASIONALLY instances are brought under notice of old plants that have been lost sight of in gardens for years again coming into favour, and one of the most recent examples of such a recovery is afforded by *Mina lobata*. This plant was introduced from Mexico in 1841, when seeds were sent to the Earl of Burlington at Holker by G. Frederiek Dickson, Esq. From Holker plants were sent to the London Horticultural Society, but being exposed in severe weather they were lost, and only two seeds saved. It does not appear to have extended beyond the gardens of a few who were interested in curious or rare plants, and it either gradually died out or became so extremely scarce as to be practically unknown to the majority of cultivators. A short time since Messrs. Haage & Schmidt re-introduced it to Europe, and now it is in the hands of most of the British seedsmen and nurserymen.

The genus *Mina* was named in honour of a Mexican celebrity, Don Francisco Xavier Mina, and this species is said to have been generally grown in Mexico for a number of years for ornamental purposes. It is nearly related to the *Ipomæas*, which it particularly resembles in the foliage, but the flowers are totally dissimilar both in form and arrangement. They are in one-sided racemes, which attain the length of 16 inches, the flowers gradually expanding from the base to the tip

which continues to elongate throughout the season. The corollas are ovoid in the bud, when they are of a bright red colour, the expanded flower being tubular and varying from red through yellow shades to white. The older flowers at the base of the raceme are of the lighter tints, and there is thus gradation in each from white or yellow to the deep red terminal buds, giving a strangely varied appearance to the plants.

*Mina lobata* is a rapidly growing plant and covers a high wall in a month or two. When in such fine condition as we saw it last month at Raby Castle, Darlington, it has a most remarkable effect, and could scarcely fail to become popular. Writing in reference to the system of culture adopted, Mr. R. Westcott observes as follows:—"The seed is sown in February in a stove temperature, and the plants kept in the same

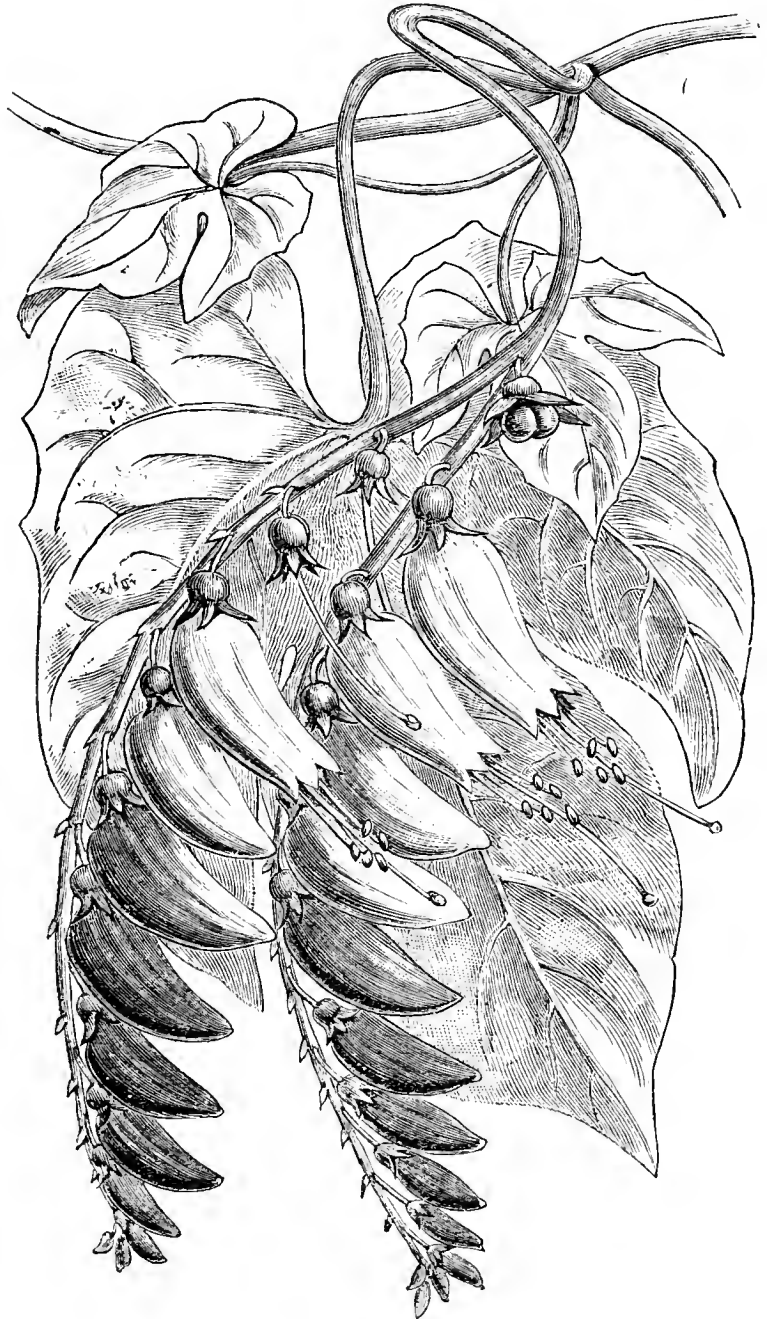

Fig. 42.—*Mina lobata*.

house until established in 3-inch pots, using light fibry soil, gradually reducing them to greenhouse and cold pit temperature. By that time they should be in 6-inch pots, which will be sufficiently large until they are planted out about the second week in June, which should be on a well-raised border against a south wall. The soil should wholly consist of light fibry loam, mixed with a liberal portion of half-decomposed cow manure. The plant, which is of coiling habit, should be trained on strong cords, and the shoots will soon reach the top of any ordinary garden wall. The plants here reached the top of a 13 feet wall this season and then ran horizontally, flowering at every joint and maturing a quantity of seed. The flowers have a novel and most pleasing effect in bouquets."



MR. EDW. HARLAND, Hon. Secretary of the HULL AND EAST RIDING CHRYSANTHEMUM SOCIETY, calls our attention to the fact that "a slight error crept into our note accompanying the illustration of the challenge plate of this Society in the Journal of 13th inst. The cups will not be completed for on 16th November, as therein stated, but on the 17th."

— THE sudden change in THE WEATHER experienced recently with severe frosts varying from 10° to 15° has effected a great alteration in gardens, all tender plants being killed, and the leaves of many deciduous trees have fallen very quickly and early. Walnut and Mulberry trees were completely denuded of their leaves in a single night. Almost the only trees that still retain their foliage fresh and green are the Elms and Planes, which present a striking contrast to the others.

— MR. G. R. ALLIS, Old Warden Park, writes:—"We have had a first taste of winter. Snow fell early on the morning of the 12th inst.; the ground was covered at daylight, but it soon melted, except in a north shaded aspect. The thermometer registered 28°, or 4° of frost, slightly injuring Dahlias and other tender plants, but the following morning was still sharper, when the mercury stood at 24°, or 8° of frost, which killed Dahlias and other tender plants. Heavy showers of hailstones fell on the 13th, followed by a slight frost at night. The weather during the week has been very cold and stormy for so early in the month, with the wind chiefly blowing from the north-east."

— A CORRESPONDENT at Hampton states that on October 13th he registered 15° of frost; 10° on the 12th, and 7° on the 11th.

— WRITING from Cardiff on the 16th inst. Mr. Pettigrew observes:—"We have had no rain to speak of, and scarcely sufficient frost to kill the Dahlias." Mr. W. Wenman, The Gardens, Hickleton, Doncaster, also writes: "We had 8° of frost here on the 12th, completely destroying Beans and Peas. We also had cold storms with hail and sleet. Some of the trees have quite lost their leaves."

— GARDENING LECTURES. — The Birmingham and Midland Counties Gardeners' Mutual Improvement Association announce the following lectures to be delivered on Tuesday evenings at 8 P.M. in the Midland Institute, Birmingham:—October 25th, "Tuberous and Winter Flowering Begonias," by Mr. J. Lee; November 8th, "Remarks on the History and Nomenclature of Noteworthy Apples," by Mr. W. Gardiner; November 22nd, "Plants for Room Decoration," by Mr. C. R. Bick; December 6th, "Notes on the Narcissi and its Varieties," by Mr. W. Spinks; December 20th, Discussion, and Election of Best Vegetables; January 3rd, General Annual Meeting and Exhibition of Chrysanthemums.

— THE second annual CHRYSANTHEMUM SHOW AT LEEDS will be held in the Town Hall of that town on Tuesday and Wednesday, November 29th and 30th. Thirty-five classes are provided for plants and cut blooms of Chrysanthemums, together with miscellaneous plants, bouquets, and stands of flowers. The prizes range from £5 to 1s. The Secretary is Mr. J. H. Clark, 15A, Briggate, Leeds.

— ON Monday, the 10th inst., MR. WILLIAM HEALE died at Hereford regretted by many friends. Mr. Heale had been connected with several nursery firms, such as Messrs. H. Low & Co. Clapton, Cheal and Sons, Crawley, and later as manager to the Cranston Seed & Nursery Company, Hereford. He also assisted in the formation of the United Horticultural Benefit and Provident Society twenty-one years ago, and had taken much interest in its advancement ever since.

— THE BEDFORD CHRYSANTHEMUM SOCIETY will hold their first Exhibition in the Corn Exchange, Bedford, on Wednesday and Thursday, November 23rd and 24th, this year. Prizes are offered for groups, specimen plants, cut blooms, together with fruit and vegetables in ninety-eight classes, the amounts varying from 2 guineas to 1s. A show of pigeons, rabbits, and cage birds will be held in connection with it. The Hon. Sec. is Mr. J. Sanders Clarke, 49, Linden Road, Bedford.

— HAM GREEN FAVOURITE TOMATO.—"T. H." writes:—"This Tomato has been grown at Ham Green for the past four years. It was raised by the present gardener, Mr. Crocker. He has a small span-roof house, 25 feet by 10 feet, with about thirty plants grown on the single rod system, and each plant carrying from ten to twelve trusses of fruit each, having from twelve to fourteen excellent fruits in different stages. The house is worth making a special journey to see. I remember seeing a house of it last April equally as good as the present one, and Mr. Crocker assured me he had been cutting all through March. It is the finest variety I ever saw, and the flavour is good. It has been grown at Chiswick this year and received a first-class certificate."

— GARDENING APPOINTMENT.—Mr. George Fisher, late gardener to the late J. C. Richardson, Esq., J.P., Glanbrydan Park, Manordeilo, Carmarthenshire, has been appointed gardener to Arthur J. Williams, Esq., M.P., Coedymuster, Coychurch, near Bridgend, Glamorganshire.

— A GARDENER of considerable note in northern Britain, MR. GEORGE JOHNSTON OF GLAMIS CASTLE GARDENS, died on the 30th ult. at the age of fifty years, leaving a widow and five children. Mr. Johnston was widely known and much respected for his cultural skill, and during the twenty-one years, in which he had charge at Glamis he maintained the gardens in high condition, and became especially celebrated for fruit culture, particularly Grapes, and it is said that he won over £300 in prizes at the chief northern shows since 1868. Mr. Johnston was born on October 31st, 1837, at Fingask, Kirkcaldy, Inverness, and served in several good gardens, including Castle Kennedy, before obtaining his appointment at Glamis.

— AUTUMN RASPBERRIES.—Mr. J. Lyon, Riddings Court, Caterham Valley, Surrey, sends us some remarkably fine Raspberries, and remarks that "They were gathered on October 17th from my garden. We are 550 feet above the level of the sea, and the garden where they were gathered faces the north-west. Two nights last week we had 8° of frost." There are several varieties which usually ripen their fruits in October, and some will last far into November in favourable seasons, but it is not often we see such fine fruits as those sent at this time of year.

— WE are requested to state that MESSRS. W. WOOD & SON, Wood Green, N., have arranged to stage exhibits of four dishes of Potatoes for competitors for their silver cup and other prizes at South Kensington on the 25th inst.

— A GENERAL meeting of the members of the NATIONAL CHRYSANTHEMUM SOCIETY will be held at the "Old Four Swans," 84, Bishopsgate Street, City, on Monday, October 24th, the chair to be taken by the President, Mr. E. Sanderson, at 7 P.M. The Floral Committee will meet in St. Stephen's Hall, Westminster, on October 26th, November 9th and 24th, and December 7th at 1.30 P.M. each day, except November 9th, when the hour of meeting will be 12 noon.

— AN EXHIBITION OF APPLES AND PEARS AT MANCHESTER, was opened on Friday last in the main avenue approach to the Royal Jubilee Exhibition, and continued on Saturday and Monday. Large numbers of fine fruits were staged, the Apples being especially good. In the nurserymen's classes the chief prizes were won by Messrs. J. Watkins, G. Bunyard & Co., Cheal & Sons, Cranston & Co., and A. J. Thomas of Sittingbourne. In the amateurs' classes the successful competitors were Messrs. Goodacre, S. Barlow, P. Thelusson, R. C. Naylor, Col. Wingfield, and F. Smith. Several classes were devoted to amateurs residing within twenty miles of the Manchester Town Hall, in which the leading exhibitors were Messrs. Upjohn, W. Nield, and Alfred Jones of Marbury Hall Gardens, which is within half a mile of the largest salt and chemical works in Northwich. The non-competing exhibits comprised groups of plants and flowers from Messrs. Dickson & Robinson, F. and A. Dickson & Sons, S. Barlow, and H. Heine; Mr. H. Merryweather, Southwell, Notts, being awarded a first-class certificate for Bramley Seedling Apple.

— A WORK on "THE CULTIVATED ORANGES AND LEMONS, &C., OF INDIA AND CEYLON," by Brigade-Surgeon E. Bonavia, M.D., of the Indian Medical Department, is about to be issued. The writer's object is mainly practical and economical, but he deals also with some questions of purely scientific interest. His researches have brought him into contact with every variety of Citrus in India and Ceylon, and he

claims that he has been able to dispose of, or at any rate to throw new light on, certain disputed points, both botanical and historical, in connection with this genus. The book will be accompanied by an atlas in foolscap size, consisting of 259 plates of outline drawings of all the varieties of Citrus to be found in India and Ceylon.—(Nature).

— THE October number of the "Botanical Magazine" contains an illustration of ANEMONE FANNINII, a South African plant discovered in 1863 at Dargle Farm, Natal, by Mr. G. Fannin, and since then specimens have been sent to Kew from other localities at elevations of 2 to 4000 feet. It is said to grow in some places to the height of 5 feet, with leaves 2 feet in diameter, the white fragrant flowers being 3 or 4 inches across. It has flowered at Kew in a cool pit, but has been found quite hardy.

— AN illustration of STATICE SUWOROWI is also given, and well portrays the character of this annual, which has obtained some favour in gardens recently. It was discovered by Dr. Albert Regel in Western Turkestan, and seeds have been distributed by Messrs. Haage & Schmidt of Erfurt. Plants have flowered at Kew on the rockery and in a cool house, and it has been observed that some plants have remained in flower for two months. The long branching dense cylindrical spikes of bright rose-coloured flowers have a very distinct appearance.

— A PECULIARLY distinct Iris is represented in plate 6960 of the same issue—namely, IRIS SARI, VAR. LURIDA. This is a relative of I. Susiana, and was flowered by Mr. R. I. Lynch in the Cambridge Botanic Garden last May. The standards are broad and curiously veined and mottled with purple, the falls being similarly broad, mottled with a brownish tint on a light ground.

— GISHURSTINE.—We are reminded of the approach of winter by the reception of samples of this valuable dubbinz for boots. Experience confirms its worth, and it may be used with service and comfort by persons whose engagements take them among wet grass and manure.

— MR. R. OWEN, Maidenhead, writes: "I enclose you a bloom of MARGUERITE CLOTH OF GOLD cut from a plant in a small 60-sized pot. The plant being in bloom some months, I could send you a quantity of such blooms from the same size pots. It is really a grand yellow Marguerite for winter blooming; in fact, it is a perpetual bloomer, as I have never been without flowers since I raised it." The bloom sent is a beautiful one, and we remember seeing some of Mr. Owen's plants late in the season flowering most freely.

— MILDEW ON ROSES.—"Nothing is more disheartening to amateurs," says "Olton," "than this terrible pest, and in the district in which I live in the midlands it is not only in my garden, but in many others where I notice it in a strongly developed stage. I think a large number of us amateurs who grow only a few and have not the experience of larger growers, would be very thankful if some of your readers could give us advice as to pruning Roses now, which are so much affected by mildew, and their treatment afterwards. Is dryness at the root a cause? for we have experienced a very hot, long dry season here, and dry through September and October."

— A WRITER in the *Indian Forester* gives the following account of "a REAL WEeping TREE":—"On my way to and from the Mussoorie Library I have noticed for some days a small pool of water in the middle of the road just above 'Auehnagie.' It struck me as something singular; and to-day when passing I noticed several drops of water fall into it; on looking up I saw it was the sap from a branch high up on a tree that was falling into it; the drops were large and were falling at the rate of one a second. I afterwards noticed several other trees of the same kind on the roadside dropping sap from their branches in the same way. The tree is a large one, called by the natives Kágashi (Cornus macrophylla?). In the spring, if the bark of this tree is wounded by an axe, the sap runs out of the wound in a great stream; some of it solidifies into a thick mucilage of a bright orange colour; it was from a broken branch that the sap was coming, broken most likely by the heavy fall of snow we had at the end of January. These trees are just bursting into leaf, but they have been weeping for the last ten days at least."

## VIOLAS.

I WILL leave to those learned in botany the task which Mr. Jenkins asks me to solve, if they can, for all Pansies, Violas, and Violets are botanically Violas, the two former of the Viola tricolor section. What I think we shall have to do is to make sections of families of our Pansies and Violas in future catalogues. Thus, Show Pansies, the old race of Pansies so dear to our oldest Pansy growers still, before the fancy Pansy became popular, which should consist of white grounds, having a regular belting of a shade of purple colour in the three lower petals, the two upper petals of a self colour, and a dark, dense, well-cut blotch in the centre. Yellow grounds, which should have a ground or body colour of a shade of yellow, with rich maroon or purple belting on the top petals, and a dense blotch; and Selfs, either white, yellow, or dark purple, or shade of purple, in each case the flower possessing a dense dark blotch in the centre, such as I have indicated in the white and yellow ground flowers. I need scarcely add that florists have rigid rules as to form, substance, belting, blotch, and colour in this section of the Pansy class.

Fancy Pansies would form another division, in which we cannot lay down the same strict rules as to colour, belting, &c.; but we look for form, substance, and smoothness, combined with bright telling colours, and for distinctness especially, for we now have such a long list of fancy varieties, quite three hundred, that distinctness combined with high class quality must be a *sine qua non* in new varieties.

All the varieties catalogued now as Violas need re-arranging into two sections, one of these to be bedding Pansies, such as Holyrood, Blue King, Cliveden Purple, Archie Giant, Adonis, Lord Darnley, Queen of Violets, Queen of Purples, and other varieties which wholly or to a great extent preserve the character of the Pansy in growth and flower. In the Viola section I think the generally distinctive character should be a close dense sturdy habit with smaller blooms than the Pansy, good constitution, very floriferous, and very early and continuous bloomers, such as Ardwell Gem, Mrs. Gray, Elegans, lutea grandiflora, Golden Prince Improved, lilacina, Countess of Kintore, Duchess of Albany, Skylark, Bullion, Duchess of Sutherland, Queen of Spring, Golden Queen of Spring, Mrs. Smith, Queen of Lilacs, True Blue (the best of all blues), and many others.

Then we come to a cross-bred race, partaking of the mixed characters of the Viola and Pansy, in which Mr. Jenkins gives Countess of Hopton a place; but as this grand variety has such a very close growing habit, is so early blooming, and continuous in flower, that I should give it a place amongst our Violas, but amongst these hybrids we must give a place to Archie Grant, Bronze Queen, Lady Diana, Paragon, Pantaloon, Unique, and such others of the same strain, also the large-flowering kinds which partake more of the Pansy character in growth and flower, and in this division Spotted Gem, Mrs. Baxter, York and Lancaster, and others would find a place.

No hard-and-fast line can be drawn as to what are really Violas and what are Pansies, and I do not see that any effort to do so is necessary. What we all want is distinctness, good telling colours, a close sturdy habit, good constitution, and very free, early, and continuous bloomers. Form in the flower of the Viola is quite a secondary matter. What the public want must possess the qualifications I have indicated.—WILLIAM DEAN, *Walsall*.

## THE HORTICULTURAL CLUB.

### OCTOBER PEARS.

THE first monthly dinner of the Club for the present season took place on Tuesday evening, Oct. 11th; there was a good attendance of members. Mr. John Lee was in the chair. Amongst those present were Messrs. F. Rivers, Balderson, Crowley, H. J. Pearson, A. H. Pearson, Strange, Cozens, and Drury. In the evening Mr. Geo. Bunyard read a paper on "October Pears," which we here give, and an interesting discussion took place, in which most of those present joined. H. Balderson, Esq., of Comer Hall, brought ten bunches of beautifully finished Grapes which had all been grown in one house without any partitions. They included such kinds as Muscat of Alexandria, Black Hamburgh, Golden Queen, Mrs. Pince, Muscat, Trebbiano, Buckland Sweetwater. He detailed his method of culture, and it was considered by all present that it was very successful, and, while all the Grapes were good, the bunch of Mrs. Pince was considered equal to any that had been shown this year as regards colour, size of bunch and berry, and complete finish. The thanks of the meeting were given to Mr. Bunyard and Mr. Balderson. Mr. C. T. Drury brought some of his very handsome and serviceable enamelled plant labels. A very pleasant and profitable evening was spent. The following is Mr. Bunyard's paper:—

In bringing before you the above subject I should, at the outset, observe that I feel there is little to be added to the present sum of knowledge on the subject, by the few remarks I am about to make in the limited time allowed me for the purpose. Owing to the late spring and the protracted drought the Pears of September will, in some cases, be in season in October, but as this is abnormal I will confine myself to those usually in season in the present month.

It has been observed by competent judges that all the good Pears may be counted on one's fingers, which, in a degree, is true. Mr. Barron's Pear Conference report gives fifteen varieties only which had over fifty votes, as the selection of 100 exhibitors at the 1886 Chiswick Conference, and Mr. Dunn gives fifteen as by the exhibitors at Edinburgh having over twenty votes, of this number the cream (nine varieties) come in season in the southern counties during October—viz., 1.



Louise Bonne of Jersey; 2, Marie Louise; 3, Beurré Superfin; 4, Beurré Hardy; 5, Pitmaston Duchess; 6, Fondante d'Automne; 7, Thompson's; 8, Comte de Lamy; 9, Emile d'Heyst. I intend to confine my remarks to the above, being those suited for dessert, and which no connoisseur of Pears would object to use himself.

1, *Louise Bonne of Jersey*.—This succeeds on the Quince and makes a fertile pyramid. The fruit is of very refreshing flavour, juicy; the best flavoured coming from standards on the Pear stock, on which it succeeds well.

2, *Marie Louise*.—Best flavoured from open trees, but seldom bears freely, as the blossom is tender; very fertile as a wall Pear and as an espalier; requires much root-pruning as a pyramid, is not happy on the Quince.

3, *Beurré Superfin*.—Very fine as a pyramid on the Quince, producing handsome richly flavoured fruit, fertile, also a good grower.

4, *Beurré Hardy*.—This possesses a rich, unique flavour; a beautiful grower as a pyramid, and very fertile; fine on a wall; succeeds on the Quince.

5, *Pitmaston Duchess*.—Large, not always of fine quality, but yet so handsome as to be worthy of culture in any form, hardy and a free bearer; succeeds on the Quince.

6, *Fondante d'Automne*.—One of the sweetest and best melting Pears, forms a fertile pyramid on the Quince, and is good in any form.

7, *Thompson's*.—One of the finest Pears; very melting in texture; thin skinned, of delicious flavour, distinct, and valuable; succeeds on the Pear, but requires double working on the Quince.

8, *Comte de Lamy*.—Particularly rich in flavour; very fertile on the Pear or Quince; rather an awkward grower, as it bears on the points, and has much bare wood as many eyes fail to start.

9, *Emile d'Heyst*.—Shape like Marie Louise, very fertile both on the Pear and Quince, very little known, but most desirable, of rich honeyed flavour. In use towards the end of October.

All the above form good cordons, except Comte de Lamy.

In order to make the October Pears complete, the following may be added as worthy of a place in the garden, though not always of choice flavour or texture, still some are valuable substitutes when the better class fail to hear:—

1, *Colmar d'Été*.—A very sweet rich Pear, profuse bearer.

2, *Graham's Autumn Nelis*.—Small, but delicious; a sweetmeat, crowded out by larger sorts.

3, *Doyenné Boussoch*.—Fertile, of refreshing acidity.

4, *Durondeau*.—Large and fertile, and fairly good.

5, *Seckle*.—Small, but delicious.

6, *Beurré Bose*.—Of rich flavour.

7, *Eyenwood*.—Bon Chrétien flavoured; a very good small Bergamot kind, most fertile.

8, *Beurré Diel*.—Of peculiar richness (end of October).

The market varieties for October would be Beurré de Capiaumont, Duchesse d'Angoulême; Rivers' Fertility, Marie Louise d'Uccle, Louise Bonne of Jersey, Pitmaston Duchess, Beurré Rose. These are for growth on standards, or better as half-standards, crop being all-important.

I cannot let this opportunity slip without a word as to culture. It is most important that the roots be kept near the surface, that they may have the benefit of the sun warmth in the soil, for it is mainly on these that the fruit depends; they are in fact the foragers for size and flavour (as against the tap roots, which provide for the woolly growth and extension of the tree). To this end root-pruning is a valuable aid; and although from the general overworked condition of many gardeners this is not so regularly carried out as could be desired, still, as it does away with much top-pruning, the operation is all-important and saves labour in other ways. October is the best time.

Mulching is valuable, but should only be carried out when the tree has a good crop, and if extra sized clean fruits are desired a previous dressing of Clay's fertiliser or a similar stimulant will be useful. The moss manure now so much in use is valuable, as it contains fertilisers in a high degree, and is neat in appearance and handy for use. We employ it with great benefit—*e.g.*, our Pears gained third prize against competitors who have grand walls and aged trees at the Crystal Palace, October 6th. Upon this mulching a liberal or rather copious supply of soft water should be given once a fortnight in the dry season. Some foliage may also be removed where it shades the fruit, and the summer removal of inside spray will further assist the ripening of wood and add size to the fruit.

Thinning must be carried out with caution until the fruit is safely set, when all double bunches may be reduced to one (unless the tree is partially cropped, when it will carry them). As regards stocks upon which the trees should be; for garden work, except in very light soils, the Quince is preferable, as its surface-rooting character is more amenable to treatment, and it also takes nourishment more readily.

In sandy soil those on the Pear stock alone should be tried, though a few choice sorts on the Quince might be grown in tubs or large pots sunk into the ground, in which of course a suitable soil could be used.

#### KEEPING PLANTS CLEAN.

I HAVE not the Journal by me to refer to my remarks on this matter, so kindly criticised by Messrs. W. Wood & Son at page 323. However, I do not think I am wrong in giving to America the credit of the "first public intimation" of the manner of preparing petroleum in a safe and effective manner. I had my information from an American

State paper of four or five years ago, and I have been employing the mixture recommended in the Journal for the past three years. I scan most of the papers in connection with our calling, and have failed to see any intimation of this manner of preparing petroleum in this country until it appeared in the Journal a fortnight ago. It is hardly necessary to point out to Messrs. Wood that preparations made for sale give no intimation of how they are made up; and as to the necessity of gardeners and others having a cheap and ready method of preparing a good insecticide there is a very strong case presented at page 322 of the same Journal, where Mr. Bardney recommends the rough-and-ready method of mixing the petroleum with a syringe. I may say in conclusion that I have no doubt that the insecticide manufactured by Messrs. Wood & Son is an effective one.—B.

#### CHRYSANTHEMUM NOTES.

##### THE INNER TEMPLE.

By the courtesy of the Benchers, the Exhibition of Chrysanthemums at the Inner Temple Gardens will be opened to the public to-day (Thursday), and will continue to attract visitors for three weeks or a month to come. This is the eighteenth season that a display of these popular autumn flowering plants has been produced under Mr. Newton's charge, and their condition gives every indication of as fine a display of blooms as he has ever had. There are 900 plants representing over 500 varieties, and though, like many others, they are somewhat later than usual this year, there is a good number of the early varieties in flower, substantial buds of the main season varieties giving promise of grand blooms within the next fortnight. The incurved and Japanese varieties are well proportioned in numbers, and some of the best of last year's novelties are included. The majority of those at present out are Japanese, and comprise M. W. Holmes, which was seen so well last season; M. Delaux, of great size; Elaine, large and pure; La Triomphante, M. Henri Jacotot, Frizon, the early and free Alexandre Dufour; remarkably large buds of Pelican being now advancing rapidly. Of incurved the Rundle family, Beverly, Aurea Multiflora, Guernsey Nugget, Lord Wolseley, Empress of India, and Refulgence are the most forward, the latter being much better than it is usually seen.

##### FINSBURY PARK.

The display provided in Finsbury Park under the management of Mr. Cochrane and his foreman, Mr. J. Mardlin, opens on Saturday the 22nd inst., and, as we are accustomed to seeing them there, the plants are in excellent condition. Fine buds are abundant, but fully a week will elapse before the majority of these expand, so that we shall have an opportunity of referring to them again.

##### CHRYSANTHEMUM SHOWS.

THE following are the dates of the principal shows to be held during the coming month, at which Chrysanthemums will be the leading feature:—The figures following the names of the places at which the shows are to be held indicate the number of days devoted to the exhibitions, and it will be seen that a large majority are two-day shows.

##### NOVEMBER.

Tuesday, 1st ...	Southampton (2)	Tuesday, 15th ...	Southgate (2)
Thursday, 3rd ...	Henfield (2)		Lincoln (2)
Friday, 4th ...	Leicester (2)		Winchester (2)
	Crystal Palace (2)		Putney
Tuesday, 8th ...	Royal Horticultural Society	Wednesday, 16th	York (3)
	Brighton (2)		Birmingham (2)
	Highbury (2)		Northampton (2)
	Southend (2)		Ealing
	Kingston (2)		Chelmsford
Wednesday, 9th	Bath (2)	Thursday, 17th	Dartford (2)
	Croydon		Bury St. Edmunds (2)
	National Soc. (2)		Hull (2)
	Ascot (2)		Barnsley (2)
	Cornwall (2)		Colchester
Thursday, 10th ...	Portsmouth (2)	Friday, 18th ...	Sheffield & West Riding (2)
	Brixton (2)		Chorley (2)
	Ipswich (2)	Saturday, 19th ...	Ramsbottom
	Weald of Kent (2)	Monday, 21st ...	Wolverhampton (2)
	Dawlish		
Friday, 11th ...	Hitebin	Tuesday, 22nd ...	Liverpool (2)
	Canterbury (2)	Wednesday, 23rd	Bedford (2)
	Street (2)	Friday, 25th ...	Eccles (2)
	Lewisham (2)		Pontefract (2)
Monday, 14th ...	Sheffield & Hallamshire (2)	Tuesday 29th ...	Leeds (2)

##### DECEMBER.

Thursday, 8th, Alnwick.

#### INDIAN EXPERIENCES.

(Continued from page 281.)

THE history of the introduction and subsequent establishment of the Chincona plant on the hill tracts of India has been often written, but a rapid retrospect may not be out of place in these papers. In introducing the plant into British India the primary object of the Government was ostensibly providing the natives of the fever-stricken districts with a cheap febrifuge. Before its introduction quinine and

other forms of Chinchona bark extract were only obtainable by the wealthy, the prices to the masses of the natives being prohibitory. It was not intended, in the first instance I believe, that the State, for any length of time at least, should keep itself in the position of a private producer and trader, and regularly place large consignments of bark on the London market in competition with private individuals. This practice, however, has been kept up ever since its adoption in the year 1872, when the trees planted at the commencement were twelve years old. In consequence of this there have been loud and general complaints by private planters against the successive Governments of the day.

It was in the year, 1859 that Her Majesty's Government engaged the services of Mr. Clements R. Markham for the special duty of introducing the Chinchona plant into India. He started on an expedition to South America in the early part of 1860, and arrived in India at the end of the same year with the first instalment of Chinchona plants. Mr. Markham was ably assisted in the arduous and dangerous work of collecting, establishing in cases, and subsequent transmission to India of the different species of Chinchona plants by Mr. Spruce and Mr. Cross, both, I believe, practical gardeners and botanists. The plants were taken to the Nilgiri Hills and placed under the care of the late Mr. W. G. McIvor, at that time Superintendent of the Government Botanical Gardens at Ootacamund, and who was subsequently appointed Superintendent of the Government Chinchona Plantations on the Nilgherries. Under his able management the plants introduced from South America were rapidly propagated and the magnificent permanent plantations of the present day established. The Government, beyond all question, were fortunate in having at hand a gentleman of Mr. McIvor's great abilities to at once undertake the work, otherwise the great success, of the experiment might not have been so rapidly achieved. Honours were in due season bestowed on the collectors and introducers of the plants, and no one grudged them these, but in the opinion of many these honours ought to have been divided. With the introduction of the plants the undertaking was only, as it were, begun, and all success in this direction might easily have been rendered abortive by subsequent mismanagement, but, as a fact, the whole of Mr. McIvor's labours from the first introduction of the plants to the complete establishment of the enormous plantations proved to be a brilliant success, but so far from his being equally rewarded with Mr. Markham and his coadjutors, we actually find Mr. McIvor in the year 1876, shortly before his death, making the following complaint to the Government of Madras: "It also becomes instructive to note the effects of this undertaking on the position of the parties employed in its development. Mr. Clements Markham, Mr. Cross, and Mr. Spruce, were the prominent agents employed in the introduction of the plants and seeds. The duty on which these gentlemen were employed was of a preliminary nature and of short duration, and the fruits of their labours depended on the judgment with which the plants and seeds were managed in this country. The great success I attained in the propagation and cultivation of these plants secured for these gentlemen a graceful and well merited reward. Mr. Markham received a bonus of £2000, and was created a Companion of the Bath; to Mr. Spruce a pension was granted, and Mr. Cross received a bonus. How different has been the effect on myself. Instead of being rewarded I have been degraded from that independent position I originally occupied. Even the ordinary increments of salary accruing from length of service in every position under Government has been denied me, and for upwards of ten years I have laboured in this department without receiving an increase of emoluments. I do not make this statement in the form of complaint, because I am not entirely without my reward. I stemmed the torrent of error which would have swept away all benefit from a great national undertaking, and my judgment and courage in doing this has met with the approbation of the civilised world. Still it is important that the illiberal treatment of myself and my department should be understood. It has retarded the development of the undertaking. It has caused all my experienced assistants to leave and seek employment elsewhere."

What made Mr. McIvor's complaint the more bitter was that he had been recently, and most unjustifiably, degraded from an independent position with regard to the Chinchona experiment to a subordinate one under the Commissioner of the Nilgiris consequent upon his indomitable pluck in support of views of cultivation and treatment of the plantations, which he knew to be right, against those of others of no experience, although holding high official positions. I may be pardoned for thus extending my remarks on the late Mr. McIvor, when it is known that at that time it was too much the custom amongst the Civil Service officials of India to look askance at successful endeavours on the part of anyone outside the pale of their own favoured community, and the very name of planter, or, worse still, gardener, was with them a byword or term of reproach.

In Mr. McIvor the successive Governments of Madras had a man of intelligence and ability, indomitable energy, and great resource, which they were not always willing to acknowledge and act upon. Mr. McIvor was appointed by the Honourable East Indian Company Superintendent of the Botanical Gardens in the year 1848 in the unenvied Civil Service, and this appointment, in conjunction with the superintendence of the Chinchona experiment he held with honour to himself till the time of his death in 1876. He was essentially a gardener, and was never ashamed of being called by that name. He lost no opportunity of upholding the honourable character of his calling, or of holding out encouragement to young men in the same profession throughout a long and useful career in India.

About the year 1864, or at an early stage in the Chinchona experi-

ment, Mr. McIvor made the discovery of what is still called the "mossing system," and which subsequently proved to be a very important and valuable one. Whether this discovery was made accidentally or otherwise is, I believe, not known. It consisted in applying to the stems of the trees a thick covering of moss, which was allowed to remain for a year, it was then removed and the bark taken from the tree by alternate strips of about 1 to 2 inches wide—that is, a strip was taken, and one left all round the stem of the tree. It was found that this process of excluding the light and air from the stem had the strange effect of increasing to a very considerable extent the alkaloids in the bark. After the removal of the first strips of bark the stems of the trees were again mossed and allowed to remain for another year before the remaining strips were removed. By this time it was found that the decorticated portion of the stem had renewed its bark all over, and presented a light coloured granulated appearance. This renewed bark in its turn was harvested, and found to contain even a greater amount of alkaloids than the original bark under the mossing process. Mr. McIvor made no secret of his discovery, but, on the contrary, strongly recommended its adoption on the Government plantations. This recommendation was met by a storm of opposition from various quarters, but chiefly from the Government Medical Department, and from the Government Quinologist, who was appointed on a large salary by the Home Government in 1867, to investigate on the spot various questions connected with the elaboration of alkaloids, the harvesting of the bark, the most economical and efficacious mode of preparing the febrifuge, &c. One instance of the kind of opposition offered may be recorded. Dr. Bidie of the Madras Medical Establishment, in a report submitted to Government, bearing date 1874, says:—"As various facts appear to me to point to the conclusion that mossing does not increase the alkaloid by exercising a fostering influence on the process by which they are eliminated from the crude sap, but that the increase is possibly obtained at the expense of the original bark." Dr. Bidie did not state in his report what these "various facts" were, and the groundlessness of this theory was soon after demonstrated by the experiments of the late Mr. Howard on the barks produced under the several varying conditions. The Quinologist himself recommended the coppicing system of taking bark to that of mossing, but Mr. McIvor had already put this system to the test and found it wanting, and so the battle went on, without any very satisfactory results even up to the date of Mr. McIvor's death. The fact, however, that ever since that date renewed barks of all the species of Chinchona under the mossing process have obtained in all the markets of the world much higher prices than those unsubmitted to such treatment abundantly establishes the great value of the discovery. Mr. McIvor made an attempt to protect his discovery by applying for a patent for the process, which was, perhaps, very properly refused. At the same time it is the general opinion in India that he ought to have been in some way amply rewarded by a Government that was not slow to take advantage of the discovery.

Private enterprise in Chinchona planting on the Nilgiris has made gigantic strides since Mr. McIvor's time, notwithstanding the steady opposition and petty annoyances offered to planters who are willing to invest their capital in the land; in fact, the development of the industry has been so great, resulting in such an enormous production of bark and a consequent reduction in prices, that planters are almost beginning to despair of realising the handsome returns they once hoped for. In addition to the Government still continuing in the position of private producers and sellers of bark on a large scale, they also continue to hamper the private planter in many ways, and their unwillingness to facilitate the efforts of private enterprise is thus complained of in a recent issue of a Nilgiri journal:—"Thousands of acres of virgin forest in the southern and other parts of India, admirably adapted, not only for the cultivation of Coffee, Tea, and Chinchona, but of numerous other products, are lying idle and unproductive because the Government choose, without assigning any reason, to put a veto on their assumption by men who would transform them from a desert into a garden, and in doing so find employment for and ameliorate the condition of thousands of natives. The old cry that India is unsuitable for the employment of Europeans is too stale to meet with further credence, and is contradicted by the prosperity of the Tea planters of Assam, Cachar, Chittagong, and the Nilgiris. The real source of this antagonism on the part of the Government will, we think, be found in the old Civil Service jealousy of Europeans unconnected with the Government obtaining any social position, wealth, or influence in the Mofussil. The members of the governing faction naturally resent the influx of a body of men who share with them the respect of the natives, and who, if allowed to become sufficiently numerous, might ultimately be called upon to assume a portion of those magisterial duties which are now reserved for their own particular service, and who in time might render that service almost unnecessary." With regard to the waste land laws the following is the state of matters at present existing on the Nilgiris:—Under the old rules rupees two per acre per annum is charged on all forest lands in addition to the original purchase money, but in no case is any sholah—i.e., forest of more than a quarter of an acre in extent given, and if there should be a spring or passing stream even these small bits are reserved. Under the same rules eight annas or one shilling per acre per annum is charged for grass lands, with the first five years free of rent. This grass land is not rich, and great care and expense have to be incurred before Chinchona plants can be induced to make a start on it, and of course growth is slow and the planter has to wait a long time for any returns.—PLANTER.

(To be continued.)

## AROUND NEWCASTLE-ON-TYNE.

## HOLEYN HALL.

A SHORT distance beyond Oakwood, on the same road from Wylam is Holeyn Hall, a most pleasantly situated residence, upon elevated ground overlooking the Valley of the Tyne, which is at this point much more picturesque than it is nearer to the great coal city, where many of its natural beauties are disfigured by the abundant factories and furnaces, and their never-ceasing smoke. The whole of the Valley of the Tyne, from Wylam on to Hexham and beyond, presents a charming panorama of fertile country and varied scenery such as few would expect to find in the "Black Country." In fact, when escaping from the towns and a few of the immediate centres of mining operations, the applicability of the latter designation is by no means apparent. So we find at Holeyn Hall gardening is conducted with few difficulties to contend with beyond those inseparable from its northern situation. For many years when in possession of Major Woods, Mr. G. Cooke had charge of the gardens at Holeyn Hall, which became noted in the district for the careful culture displayed in them, and now under the charge of Mr. Irving every effort has been made to maintain their reputation. There is no attempt at elaborate display or sensational effort, but the work is performed in a quiet, unassuming, creditable manner, such as all true lovers of gardens like to see. The house itself occupies a prominent position commanding a fine prospect, with a well-kept lawn in front and a neat balustraded terrace. Upon the walls of the house are several fine plants of *Cotoneaster microphylla*, which constitute an interesting feature both for their rich dark green leaves and freely produced bright red berries. Alternate with the *Cotoneasters*, some of which occupy considerable space, are globular specimen Golden Hollies about 4 feet high, evenly clipped and highly coloured. Formal specimens of this character are sometimes quite out of place, and where they are employed too freely they impart an artificiality to a garden that can satisfy very few persons, but planted in narrow borders near the house, their bright colours contrasted with the dark *Cotoneasters*, they have an excellent appearance. An elegant conservatory of moderate size is close to one side of the house, and is furnished with flowering plants varying according to the season, Zonal Pelargoniums being much valued for their floriferous habit and rich colours. Now that so many varieties have been raised in all the sections, including the graceful Ivy-leaved type, it is comparatively easy to have a succession of flowers throughout the year, and for brilliancy of colouring there is scarcely any plants to equal them: even the tuberous Begonias pale before them. The double varieties are so useful for cutting, too, the individual flowers when wired being available for either buttonholes or bouquets. The glass accommodation is not very extensive, but there is a range of vineries and Peach houses from which good crops of fruit are obtained. A large and healthy tree of Lord Palmerston is especially notable amongst the Peaches, and at the end of the range a division is devoted mainly to Roses trained on a curved trellis in front. *Gloire de Dijon*, *Cheshunt Hybrid*, and *Homère* are the favourites, the second named being uncommonly fine.

Leading from the terrace is a beautiful grass slope bordered by a rockery and shrubbery, as shown in the illustration (fig. 43). The lower portion of this is planted with the ordinary alpine and dwarf hardy plants that succeed well in such positions, and being backed up with fine Hollies and various ornamental Conifers, with a selection of deciduous trees and shrubs, a diversified and effective feature is formed. In other portions of the garden there are large specimen Oak and Beech trees, the arboretum being somewhat rich in Conifers, the majority of which do well, but *Abies Pinsapo* does not thrive as well as might be wished, though *A. Douglasi* is represented by several vigorous specimens, and *Wellingtonias* are good.

The kitchen garden is well cropped with vegetables, and is also exceptionally well stocked with fruit trees, espaliers and trained wall trees being uncommonly fine. The espalier Apples and Pears are remarkable, for seldom are such excellent old trees seen with long straight stems and producing fruit by bushels. Upon the walls are some good Pear trees grafted with several different varieties, and in two or three cases where the varieties have been selected specially for the different seasons at which they ripen, the effect is curious and interesting, a supply of fruit being obtained over a long period, some being ripe and fit for use long before the others. These seem to have been some of the experiments with which Mr. Cooke amused himself, but it was an amusement of a practical character, for many an old tree has had its vigour partially renewed by a careful system of grafting.

## NEWTON HALL.

A sharp drive behind a stout nag guided by our friend, Mr. Dundas Macrae, and the Newton Hall estate, near Stocksfield, was reached, owned by Miss Joicey, the heiress of the late Colonel Joicey. This gentleman may be classed amongst many of whom Northumberland is justly proud as having by sheer force of intellect, business ability, and energy advanced themselves far above the ranks and amassed fortunes that excite the envy of princes. It is such as these who delight in great works, and the estate at Newton Hall is a substantial monument to the taste and liberality of its late owner.

The estate consists of about 5000 acres, a large portion of which is situated on land 600 feet above sea level, and consequently not only commands extensive views, but also a considerable diversity of surface. It is about twenty years since the improvement of this place was taken in hand, walks and drives were formed and planting conducted upon an extensive scale, the real effects of which are only just becoming

apparent. For several years the gardens had that appearance of newness which is always so noticeable in such establishments, but now the trees are assuming somewhat of their true proportions the grounds have a more natural and clothed effect. Indeed, very shortly a work of another kind will have to be taken in hand—namely, thinning, as there is a danger that otherwise good specimens may be spoiled by overcrowding now they are advancing so fast. In forming arboretums and shrubberies that are desired to develop and retain their beauties over a long period it is quite as necessary to avoid crowding as it is to make a judicious selection of species and varieties suitable to the district. Sometimes, however, with a view to securing an immediate effect thick planting is practised advisedly, and then thinning requires still closer attention.

The illustration (fig. 45, page 344) gives a view of Newton Hall and a portion of the grounds from the lake, but the photograph was taken at too great a distance to do full justice to either. In the lake, at the time the photograph was taken, the celebrated Grace Darling boat was moored, and that is its usual position, but this year it has formed a special attraction in the Newcastle Jubilee Exhibition, to the Council of which it was lent by Miss Joicey for the season. There is a fine expanse of water, and from that the ground rises gradually, and in some places steeply, to the house and gardens, while a still higher elevation—an observatory not shown in the view—commands one of the most extensive prospects to be obtained in any private garden in the kingdom. Upon a clear day the view is magnificent. In a westerly direction can be seen Hexham Valley and town, to the north the Cheviot Hills bound the prospect, while in the direction of Newcastle the Tyne Valley forms the chief feature. Fine intermediate tracts of cultivated and wooded country fill up the picture, while in what may be termed the foreground we look down upon the Newton Gardens, with their masses of trees and handsome vigorous Conifers, *Abies Douglasi*, *A. Pinsapo*, with *Deodars* and *Pines* standing out conspicuously. The grand drive to the Hall, over a mile in length, can be traced by its fine banks of shrubs on each side, luxuriant beds of Portugal and common Laurels, strong clumps of *Berberis Darwini* and *Mahonia aquifolia*, with steeper, drier banks of *Furze* and *Ivy*, which are allowed to grow with their natural freedom, except preventing their undue encroachment upon the drive or other occupants of the banks. Both the common single and the double *Furze* are well adapted for such positions, and we have seen more than one good instance of the picturesque effect produced by planting them freely as marginal banks to carriage drives. One capital example is afforded at Shirecliffe Hall, Sheffield, and when the *Furze* is in flower it is something to remember. The *Mahonia* is equally valuable, and few strong-growing hardy plants possess so many recommendations—glossy dark green foliage, and profusion of yellow flowers followed by abundance of clustered purplish fruits that in themselves are ornamental in no ordinary degree. *Berberis Darwini* and *B. stenophylla* cannot be surpassed for the richness of their flowers, and a large bed of the former constitutes a charming picture.

Of the glass houses the special attraction is the conservatory, a handsome and commodious structure, 150 feet long, 40 feet wide, and about the same in height. This is near the house with corridors leading from it, and being now well furnished with large specimen Tree Ferns and Palms it has quite a tropical appearance, though there is also a combination of plant inhabitants of the temperate zones in both hemispheres. Amongst the larger specimens are finely proportioned examples of *Dicksonia antarctica* and the more seldom seen but distinct *D. squarrosa*; the stately *Cyathea dealbata*, 32 feet high, with a fine crown of fronds, and *C. medullaris*, which is as vigorous as if in its native soil and climate. Then of the Palms *Seaforthia elegans* and *Chamaerops Martiana* are notable for their size and health, while that rapidly growing tree *Araucaria excelsa* rises amongst smaller plants with its characteristically straight stem and peculiar whorls of flat angular branches. As a pillar plant the variegated *Euonymus latifolius* is effective, an example 8 feet high with clear well-marked variegation showing its value to the best advantage. *Fuchsias*, *Camellias*, *Abutilons*, *Cordylines*, and *Dracænas* are freely used; large *Hydrangeas*, the fragrant *Rhynchospermum*, variegated *Aralias*, with *Roses* and *Lapagerias* and climbing plants on pillars, arches, and roof, contribute to the attraction of the house. Innumerable small plants of the usual decorative character are employed, and in the corridors are large plants of *Acacia dealbata*, *A. affinis*, *Fuchsia refulgens*, *Lantanas*, *Begonia metallica*, and *Laurustinus*; the last named being found very useful in pots for indoor decoration, as they flower well and last a great time with ordinary care.

The stove contains a large miscellaneous collection of heat-loving plants in all stages, from the small sp. cimens suitable for table decoration up to those of exhibition size, *Crotons*, *Colensés*, *Alocasias*, and *Achimenes* being favourites. *Acalypha tricolor* is also much valued in small pots, and excellent plants are obtained within a year from the time the cuttings are inserted. The useful *Pancreatium fragrans* is another valued stove plant at Newton Hall, its flowers being of such a pure white, so sweet, and so freely produced that it cannot be over-estimated. Some of the most successful bouquetists employ the flowers of this *Pancreatium* whenever they can procure them, and with a succession of plants they can be had during a good portion of the year. They have not the substance of *Eucharis* it is true, but their long petals render them much more graceful. *Eucharis*s, however, are also well grown at Newton, and there are some extraordinary specimens 5 feet in diameter which have had 120 flowers open at one time. They are grown on the "high pressure" system, but so far from suffering they are in the most vigorous health without a



suspicion of the grower's great enemy, the Eucharis mite. After flowering the plants receive six weeks' or two months' rest, and it is found easy, with liberal treatment, and not too hard forcing, to flower them five and six times a year. Allamandas have been long grown with considerable success in this garden, and about twenty years ago a variety raised by Mr. Wardle, formerly gardener there, was brought into prominent notice under the name of Wardleana. Small plants were exhibited at South Kensington in 60-sized pots, and were much admired for their dwarf compact growth and free-flowering habit, as even those diminutive plants had several large flowers each. After comparison with A. Hendersoni, which was certificated in 1864, A. Wardleana was regarded as synonymous with that, or at least too much like it to be readily distinguished. A. Hendersoni has been said to be a hybrid between A. cathartica and A. Schotti, but the evidence is not quite clear respecting its origin, and some regard it as an introduced plant. Concerning its beauty and usefulness there cannot be any difference of opinion, however, and the best proof of this is afforded by the large numbers grown in British gardens.

The fruit houses comprise several early and late vineries, the Vines in satisfactory fruitful condition, such late varieties as Alicante and Lady Downe's bearing excellent crops of well-coloured Grapes at the

THE STRUCTURE OF FLOWERS WITH REFERENCE TO INSECT AID IN THEIR FERTILISATION.

IN the year 1793 Christian Conrad Sprengel published his interesting treatise on the structure of flowers with special reference to insect aid in their fertilisation. This book was almost wholly neglected for more than half a century. Nevertheless, it contains, with some fanciful ideas, the germs of the doctrine now generally held, together with many excellent illustrations of it. That eminent naturalist, the late Charles Darwin, published in 1862 his admirable treatise on the fertilisation of Orchids by the aid of insects. Since that time a copious special literature has appeared on the subject. We may mention the names of Herman, Müller, Delpino, Hugo von Mohl, and Hildebrand, amongst Continental writers; Charles Darwin and Sir John Lubbock, amongst our own countrymen; and Dr. Asa Gray and Dr. Goodale amongst our brethren across the Atlantic.

Linnaeus and his immediate successors taught that the adjustments in hermaphrodite flowers were such on the whole as to secure the application of the pollen of its stamens to the stigma of its pistil or pistils. "The present view," to quote the words of Dr. Asa Gray, "is that this is doubtless strictly secured in certain flowers of a moderate number of



Fig. 43.—HOLEYN HALL.

time of my visit. Madresfield Court is successfully grown, and little difficulty is experienced in obtaining well-coloured bunches of fine berries free from cracking by allowing liberal growth. There is a convenient Peach range, occupied by large vigorous but fruitful trees, Royal George, Noblesse, Late Admirable, Prince of Wales, and Grosse Mignonne being the best Peaches, with Elruge, Lord Napier, and Pine-apple as Nectarines. Several other smaller houses are devoted to various purposes—for instance, there is a Cucumber house where from two plants of the variety Duke of Edinburgh, 200 fruits have been cut. There is also a Melon house, where from Eastnor Castle, Read's Hybrid, and Gilbert's Scarlet Flesh a plentiful supply is obtained. The kitchen garden consists of four acres of land, mostly enclosed by walls, and upon a warm southern slope, a position that greatly increases the value of a kitchen garden in this part of the country. It is admirably cropped with all the most useful vegetables, and the walls are covered with trained fruit trees. Cherry trees are a special feature on the walls Morellos and May Dukes being grown very largely, the fruit being supplied for preserving and other purposes by the hundredweight.

Newton Hall garden is under the charge of a thoroughly practical gardener, Mr. D. Macrae, and every department indicates the care exercised in its supervision. It was indeed a matter for regret that we could only spend so short a time with our hospitable guide, but prior engagements had to be kept, and in early evening we were therefore speeding back to Newcastle well satisfied with the day in the Wylam district.—LEWIS CASTLE.

species, but never in all the flowers of any such species; that in ordinary flowers where it may commonly take place, it is not universal; that in the larger number of species there is something or other in the floral structure which impedes or prevents it." It will be gathered from this definition that some flowers are adapted for close fertilisation, some for cross-fertilisation, some for either. Before proceeding further, let me state for the information of those who have not given much attention to the construction of flowers that they consist of two kinds of organs—viz., what have been apparently called protecting organs or floral envelopes, which when of two sets are named calyx and corolla; and the essential reproductive organs which co-operate in the production of seed—the stamens and pistils.

"A complete flower," to quote from Sir John Lubbock, "consists of (1) an outer envelope or calyx, sometimes tubular, sometimes consisting of separate leaves called sepals; (2) an inner envelope or corolla, which is generally more or less coloured, and which, like the calyx, is sometimes tubular, sometimes composed of separate leaves called petals; (3) of one or more stamens, consisting of a stalk or filament and a head or anther, in which the pollen is produced; and (4) a pistil or an ovary, which is situated in the centre of the flower and contains one or more seeds or ovules. The pistil consists of a stalk or style and a stigma, to which the pollen must find its way in order to fertilise the flower, and which in many familiar instances forms a small head at the top of the style. In some cases the style is absent and the stigma is consequently sessile." For our present purpose the stamen may be regarded as the

fertilising organ, and the pistil as the seed-bearing organ. In an ordinary flower the pistil is surrounded by a row of stamens, and at first sight it would appear that a more simple arrangement for the reproduction of the plant could not well be contrived. The pollen would seem to be arranged to fall upon and dust the stigma of the pistil, and effect what is known as close fertilisation. This does happen with some flowers, chiefly with the inconspicuous ones. In the largest number of flowers with a gay corolla, or which emit a sweet scent and possess honey-glands, cross-fertilisation is the rule and close fertilisation the exception.

There are various contrivances in these flowers which effectually prevent self-fertilisation. In many species the stamens and pistils are situated in different flowers. Such species are named *diclinous*; when the stamens and pistils are situated in different flowers on the same plant, the species is called *monœcious*; when on different plants *dioecious*. Darwin has classified flowers into *Anemophilous* (literally wind-lovers) and *Entomophilous* (insect-lovers), denoting wind-fertilised and insect-fertilised. It is not my purpose in this paper to treat of the former, but will observe that wind-fertilised flowers are mostly neutral or dull in colour, destitute of odour and honeyless. Pines, Firs, and other *Coniferae* are examples of *anemophilous* plants. Dr. Asa Gray observes that "Insect-fertilisable or entomophilous flowers are correlated with showy colouration (including white, which is most showy at dusk), odour or secretion of nectar, often by all three modes of attraction to insects combined. Some insects, moreover, visit flowers for their pollen, a highly nutritious article, and ordinarily produced in such abundance that much may be spared. The showiness of the corolla or other floral envelopes is an attractive adaptation to fertilisation, enabling blossoms to be discerned at a distance; nor do we know that fragrance or other scent, or that nectar, subserves any other uses to the flower than that of alluring insects."

Adaptations in the pollen of such blossoms for transportation by insects are various. Commonly the grains are slightly moist or glutinous, or roughish, or studded with projection, or strung with threads (as in *Oenothera*), so as not to be readily dispersed in the air, but to have some slight coherence as well as capability of adhering to the head, limbs, or bodies of insects, especially to their rough surfaces; and in two families (*Orchidaceae* and *Asclepiadaceae*) the pollen is combined in masses and with special adaptations for being transported *en masse*. With this the stigma is usually correlated, by roughness, moisture, or glutinosity." Sprengel was the first to discover that in many species where the stamens and pistils are situated in the same flower they do not mature at the same time; consequently the pollen cannot fertilise the stigma. Sometimes, as in the *Arum*, the pistil matures before the anthers. Such plants are called *proterogynous* (or *protogynous*). In others the anthers mature before the pistil. These plants are named *proterandrous* (or *protandrous*). The familiar *Arum maculatum*—the common *Arum* or *Lords* and *Ladies*—of our woods and hedges is a good example of a *proterogynous* plant. The well-known green leaf encloses a central pillar which supports a number of stigmas near the base, and of anthers somewhat higher. Nothing would seem easier at first sight than that the pollen of the anthers should fall on and fertilise the pistils below them. But this does not take place. The stigmas mature before the anthers, and by the time the pollen has fallen have become incapable of fertilisation. It is consequently impossible for the plant to fertilise itself. Owing to the construction of the spathe the pollen cannot be carried away by the wind. What happens is as follows:—The pollen when shed drops to the bottom of the tube, where it remains secure from disturbance by wind. Small insects attracted by the showy central spadix, or the prospect of honey or shelter, enter the tube while the stigmas are mature. Above the anthers and growing from the central pillar is a fringe of hair pointing downwards. This contrivance allows small insects to enter, but effectually prevents their exit until the stigmas have matured. After a while the stigmas have ripened, and each secretes a drop of honey, thereby rewarding the insects for their imprisonment. Then the anthers ripen and shed their pollen, which falls upon and dusts the insects. Shortly after the hairs referred to shrivel up and the insects are set free. They carry the pollen with them, and on their visit to another plant can hardly fail to deposit some of it on the stigmas. In this manner cross-fertilisation is secured. I have often noticed a large number of small insects, especially flies, safely imprisoned in the *Arum* before the hairs have shrivelled up.—W. G. WHEATCROFT (in *Journal of Microscopy*).

(To be continued.)

#### ZONAL PELARGONIUMS AT CHILWELL.

A GRAND display of these is provided at Messrs. Pearson's, Chilwell Nurseries. The plants kept for show purposes are neatly arranged in a lean-to house 100 feet in length. All shades of colour are found, the plants carrying luxuriant foliage and immense trusses of bloom, make a very gay appearance at this dull season of the year. I am told that most of the plants have been in flower during the whole of the summer, and seem likely to remain so for months to come. I will name a few of the latest and most distinct varieties. Charles Mason, supposed to be the finest scarlet variety yet raised, has a fine bold truss with immense flowers. Eccentric is salmon coloured, shaded orange, a decided acquisition, quite a novelty in colour. Eurydice is a good habited lilac pink, very free, and should be good for specimens. International has the truss and flowers very large. Lady Chesterfield is salmon tinted suffused with orange, pretty and effective. Lady Francis Russell, a clear

rose pink, a noble flower, very distinct. Another of the lilac pink section is found in Mrs. David Saunders, with a clear white blotch on the upper petals. By far the largest flower in this class is the Rev. R. D. Harris, salmon scarlet, a much admired variety. The whole of these varieties were raised at Chilwell, and some very promising seedlings will be heard of next season.—W. B.

#### REVIEW OF BOOK.

*Vines and Vine Culture.* By ARCHIBALD F. BARRON. London: *Journal of Horticulture* Office and Royal Horticultural Gardens, Chiswick.

THIS volume is entitled by its author as a "new and cheaper edition, revised and enlarged," of a work which is a standard one on the subject on which it treats. This cheaper and at the same time more complete edition will be a boon to many gardeners who did not feel themselves justified in expending half a sovereign on a work however excellent; but now they can have what is equally useful, or more useful, for half the money, not many of them will be content till they possess the new volume. The price of the work has been reduced, as is stated in the preface, because the employment of smaller type and printing the illustrations with the text materially decreased the cost of production, while at the same time space was provided for important additions.

The work now consists of 189 clearly printed pages, and contains sound information on Vine culture in its various aspects and in fuller detail than can be found elsewhere. In the historical sketch it is just possible that Mr. A. Pettigrew of Cardiff Castle may not entirely concur in the intimation that the cultivation of Grapes in the open air for wine-making at Castle Coch is "not considered to be very successful." There are nearly 10,000 Vines grown at Castle Coch, and the results are considered so satisfactory that preparations are in progress for planting 50,000 more. It is not, however, to the culture of Grapes for wine-making, but to their production in the best manner for dessert purposes that the work is devoted. This is the practical view of the question, and as the contents of almost every page shows, Mr. Barron is a master in the art of teaching the multitude who know less than he does how to grow Vines from the insertion of buds to the production of bountiful crops of Grapes.

It is not to be expected that all cultivators will give unqualified adherence to every line of advice in the book; yet, nevertheless, where a method may be dissented from by some persons evidence can be adduced that the same method has proved highly satisfactory. On few aspects of Vine culture is there perhaps a greater divergence of opinion than on the treatment of young Vines during their first season of growth, some cultivators advocating and practising what is known as the rambling system, while others restrict the growths to a reasonable extent, treating them as they would treat Vines that are prepared for fruiting in pots—*i.e.*, topping the leader at a given height of 9 to 10 or more feet, subduing the laterals and devoting the resources to the development of the best possible main leaves on the lower as well as the upper portion of the cane for feeding the buds. This plan was adopted by Mr. William Taylor with the celebrated "Vines at Long-leat," and subsequently with those at Bath; that have already afforded testimony that it was not very erroneous. A house of young Muscats at Chatsworth, worked on the method, has this year been one of the finest features of that fine garden, and it is not easy to conceive that better results could have been accomplished by the adoption of any other plan of routine. Some time subsequently to the preparation of the notes on Abberley, which appeared last week, we had the pleasure of inspecting the good work in that garden, and some of the best of it was represented in a house of Vines planted in the spring, and which are undoubtedly capable of bearing a heavy crop of fine Grapes next year. These Vines have not been grown on the rambling system, and it would be difficult to find stouter, harder, and more fruitful canes. They were treated substantially in accordance with Mr. Barron's instructions for preparing canes for fruiting in pots on page 73 of the volume before us. This plan is, however, not advised in respect to Vines planted out, but on the contrary, we are told on page 41 that—"Once fairly started young Vines are all the better for the first summer to be allowed to grow and ramble pretty freely, with as little checking and stopping as possible." The reason for this is given in two lines (for the instructions in the work are commendably concise and to the point)—namely, "The more leaves and shoots developed the more roots produced, and the stronger the foundation laid for the future."

This plan intelligently carried out, including cutting down closely the rambling growths, has given satisfaction to cultivators who are not satisfied with ordinary produce, and therein rests its justification; but is there not a danger in the hands of the comparatively inexperienced, of there being few "developed" leaves in the thicket of growths? and in that case are not the necessarily imperfect leaves exhausters of the border and the Vines rather than supporters? and do not an undue proportion of the roots then produced perish in the winter? This point is not dwelt on with the object of questioning the soundness of Mr. Barron's teaching, which we know is based on successful practice, but his observations provide an opportunity for presenting the alternate plan for the consideration of those, and they are many, who are interested in the subject.

The pruning of newly planted Vines is a subject of perplexity to many growers who have not had long experience; indeed, as Mr. Barron states, "the first question that is generally asked by the uninitiated, is this, 'To what length shall I prune my newly planted Vines?'" and his reply is, "Our general answer is, Cut them as low down as you can, even



to within 3 or 4 inches of the ground, if it is light, but if there is a wall shading the lower part, then stronger Vines should be planted, and cut back at the first pruning to two or three eyes above the level of the wall plate—i.e., the line of light." All this is very good advice, and the question may perhaps be summed up in some such way as this—the weaker Vines are the more closely should they be shortened, and the stronger they are the longer the canes may be left.

But there is another point in connection with the planting and pruning of young Vines that ought not to be overlooked, and this is shortening or disbudding them *before* planting. Planting Vines with, it may be, comparatively few roots and weak canes 8 or more feet long, and leaving these intact with all their buds, is one of the commonest and greatest mistakes of the inexperienced, and the cause of many Vines refusing to make satisfactory growth the first season. We do not know whether Mr. Barron has given sufficient prominence to this phase of routine, for the work teems with so many good hints and vital points that it is quite easy to overlook some of them in a quick glance through the pages.

Relative to the new matter in the book we find something of interest on the setting and non-setting of Grapes, and cite a short and highly suggestive paragraph:—

"Herr Stefan Molnor, director of the school of Vine culture at Buda-Pesth, has observed that the 'free-setting' varieties of Grapes have the stamens erect, forming a cluster round the stigma; whilst the 'bad-setting' varieties have the stamens deflexed or falling away from the pistil, so that the pollen does not so readily reach the stigmas. Dr. Englemann has also observed the same peculiarity, and states that 'the fertile plants are of two kinds—some are perfect hermaphrodites with long and straight stamens, the others bear smaller stamens, shorter than the pistil, which soon bend downwards and curve under it, these may be called imperfect hermaphrodites and do not seem to be as fruitful as the perfect hermaphrodites unless otherwise fertilised.'"

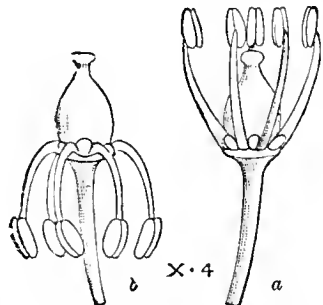

Fig. 44.—Flowers of the Grape Vine showing position of stamens, a, erect, free setting; b, deflexed, shy setting.

One of the most important chapters in the book and quite new is that on commercial Grape culture. There is more information in it of a reliable kind than we have yet seen in the space of the half dozen pages. The chief British growers of Grapes for market are enumerated, and the magnitude and method of Grape culture in Jersey described. We are told that one London salesman disposed of about 250 tons last year, and that the aggregate market supply of English grown Grapes is nearly 400 tons; that a fruiterer in Kensington sold to his customers last year 40,144 lbs., the cost price of which amounted to £2113 14s., or a little over a shilling a pound. The dates of sales and prices obtained by Mr. Webber are given throughout the year, and we are informed that some of Mr. Bashford's vineries in Jersey are 890 feet in length by 44 feet wide. Methods of packing Grapes are also illustrated, and a N.B. is appended to the chapter worth remembering—namely, "Never send Grapes to market on Saturday."

This excellent volume goes to the world with our high commendation as useful to all who grow or are intending to grow Grapes, and indispensable to most of them who desire to feel on firm ground in their procedure. It is dedicated to Dr. Robert Hogg.

### NOTES ON EUCHARIS CULTURE.

I HAVE not the remotest idea who your correspondent "R. M. A." is, or whether we ever held a conversation on the subject of the Eucharis disease. I daresay it is possible, for I have been much interested in the subject for a good number of years. I ought to be pleased to find an experienced Eucharis cultivator boldly embodying the views I expressed some years ago. I am not, however, but should have been gratified if my more recent contributions on the subject had been confirmed instead of being mildly taken to task for changing my opinions.

My earlier opinions on the disease were expressed with as much sincerity as my later ones. There is a tendency when certain ideas have once been expressed to cling to them whether they are right or wrong. Such methods cannot be too strongly condemned, for I have found that through failure we add to our store of useful knowledge much more than we do by success. I have modified my views on several subjects, and this has been brought about, not by success, but through failure, and I have not been afraid to communicate the results for the benefit of others. We are often too elated by success, and overlook the facts that result in successful attainments.

I do not know that I have ever used the exact words attributed to me by "R. M. A.," "that I could produce the disease and cure it," but I have said, and written, that the disease was brought about by the cultivator, and could be prevented. This may be practically the same, but at that time I thoroughly believed that the Eucharis mite was not a reality. That plants were diseased I never doubted, but I attributed the cause to the method of culture that had a few years previously been placed before the public and strongly urged—namely, growing the plants without rest. Planting out the Eucharis became all the rage in

beds over hot-water pipes, and by these means they could be flowered four times in the year. This, as I have argued, and again contend, might be accomplished one year, but it could not the next. That they can be flowered four times in one year is a fact, counting from the time they first flower, but the growth had to be made before they flowered first, and no allowance was made for this. Keeping the plants continually growing was the basis upon which I formed the opinion that the disease was brought about by the cultivator, and could be prevented if he followed a more natural system and allowed the plants a season of repose as Nature demands. By the violation of this law disease may be caused, and under such circumstances my previous views still hold good. While my plants remained healthy, and they grew and increased like weeds at one time in these gardens, I attributed much of the success to a judicious periodical system of resting them.

This brings me, however, to consider "R. M. A.'s" view of the case, for he believes that the mite is produced by resting or retarding the plants. Disease may be caused by retarding or carrying the process of resting to the extreme, as he appears to have done. But when he attributes the appearance of the insects to this cause—that is, a check to the plants, he opens up, to my mind, the vexed and questionable theory of spontaneous development of insect life. I could more readily believe that the insects were in existence, say, in the soil ready to attack the plant the moment it was brought into a suitable condition, or directly disease from any cause manifested itself. But this is a very doubtful view to take, and could only be proved by taking a thoroughly healthy plant and placing insects in the pot and watching the result. I had intended to test this matter, but my experiments with Eucharis have been upset by the disposal of our plants. I promised to record some experiments I was conducting, but I was prevented carrying them out. I received orders to sell the plants, and was determined if mites still existed on my Eucharis they should not prove a nuisance to any person, and so I destroyed them. Under the circumstances I am sorry that I did so, for I could before now have told if the plants were clean or not. All I can say is, after the skinning they received they soon commenced to root and grow again vigorously, and would, in the course of the season, have made good flowering bulbs.

I am convinced that if the presence of the mite could be determined directly it attacks the Eucharis it could quickly and effectually be destroyed by washing the roots and bulbs thoroughly in any insecticide that would destroy aphides or thrip, but when they eat into the bulbs cleaning becomes a tedious and difficult process. To try and eradicate this pest may not be worth the trouble when clean plants could be obtained to start again with. This would, perhaps, not be a difficulty with "R. M. A." or myself at one time, but many are not placed in such favourable positions. I think it right to try and overcome such difficulties for the benefit of others.

Your correspondent is evidently more certain of success than I should dare to be if I had once discovered the presence of the mite at the bulbs of my Eucharis. I hope his bright anticipations may not be blighted by finding before long that he has too hastily come to a conclusion. I thought again and again that I had overcome the pest by the plants starting freely and vigorously into growth, while the root activity was all that could be desired. But hope was quickly dispelled by the plants assuming their old habit of going yellow round the margins of the leaf. I have had them displaying every signs of doing well from three to nearly twelve months, but I found at last that this was only the result of the reduced numbers of the insects. The more thoroughly they were cleaned the longer they appeared to do well. I sincerely hope our friend will not be disappointed in finding the plants only grow and do well while the insects are increasing their numbers until they bring growth to a standstill.—WM. BARDNEY.

### FRUIT TREE PLANTING.

ALL persons laying out new gardens, or betaking themselves to the conducting of old ones, with the soil of which they are imperfectly acquainted, should, first of all, well ascertain the character of both soil and subsoil. As to wetness, or, as practical men term it, "sourness," all the world knows that draining is the only radical cure. The opening of a few holes here and there will soon show if stagnation exists. But then there is the surface-soil to be considered; this may be the best loam imaginable for fruit culture, and yet too tenacious. It has been affirmed by men of sound practice that there needs little nicety in testing land as to its mere mechanical character, and that any land or soil on which the water stands for three days after a heavy rain has ceased, affords a most decided case for drainage. I do, indeed, think this matter indisputable; and I also think that, as an off-hand rule, nothing can be better. The character of the subsoil, however, exercises a most important influence on the welfare of tender fruit trees. It matters not talking about platforms if the bottom soil is ever damp, perhaps wet, and this brings us back to thorough drainage. But we must proceed to examine still farther the platform affair.

I advise strongly, then, that wherever the least amount of grumbling exists about low situations, damp air, damp soil, and that sort of ill usage which a garden here and there lays claim to—a sort of unenviable pre-eminence—drain, elevate; what ought not to be done below the ground level do fearlessly above. An honest Hibernian once remarked that he had, in the course of a long life,



observed that, however people might elbow each other, there was ever lots of room overhead. And so with fruit trees and their roots. If you have not depth enough below, or that depth is of an improper character, why then go upwards—above the ordinary ground level. Some good gardeners have affirmed that the best way to plant fruit trees in general is to set them on the surface of the soil and to pile the proper compost over them; and, in good truth, if we must thus lump and generalise things, better advice can scarcely be given.

One thing here I would name, or rather suggest, that, what gardeners term a sound or adhesive loam, should enter into what little compost is considered requisite; I care not if it be only two barrowfuls. I do not, by any means, say that good fruits cannot be produced without this loam of the practical gardener; but this I will fearlessly affirm, that if we were to convene a jury of gardeners—genuine ones, I mean—as to the benefits derivable from the use of a little loam, as to fruit trees, that jury, if composed of a score of those bronzy-looking gentlemen, would not possess three dissentients. I have found three barrows of loam, if pretty adhesive, sufficient for any fruit tree, on a dwarfing system, providing the ordinary soil is what may be termed good garden soil.

half-rotten leaves and shrubbery rakings form more than half this mixture. The best way is to collect, the moment the leaves fall, all rakings, garden clearings, and rubbish of any kind, and at once place it in some sheltered spot to ferment. All coarse grass, lawn mowings, &c., which can be come at may be blended with the mass, and the whole thrown into a high state of fermentation; and as soon as a fair amount has been got together, say by the beginning of December, my practice is to coat the whole over a foot thick with old hotbed linings, which had originally been about two parts leaves and one part dung, but which, having been used for the above purpose in the last spring, have become nearly rotten. This shuts in the fermentation, and the heap may thus lay, with any additions, until March, when it is turned and mixed thoroughly, and well broken by forks.

Such a surface-dressing I would give every second year to all choice fruits planted above the level as here described. If such practice is carried out, and no spade or hoe work is permitted over the stations, it will be found that trees will come into bearing earlier, will continue bearing more steadily, will make little surplus spray, and at all times ripen well both blossom buds and fruits. —N. R. E.

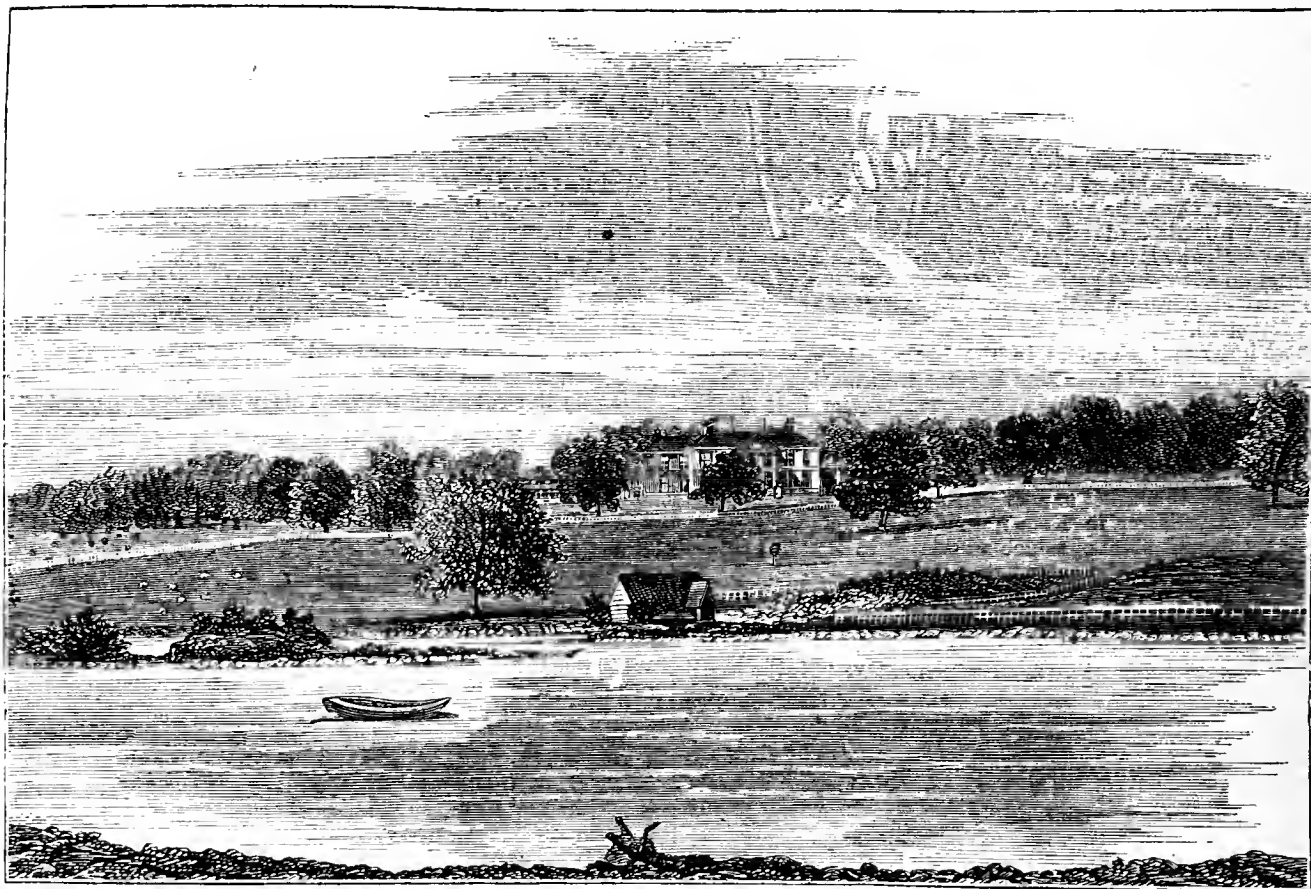

Fig. 45.—NEWTON HALL (see page 340).

I am of opinion, however, that if a more liberal amount of strong loam could be given, that fruit trees in general would benefit much by being planted on the surface of the soil without any excavations, provided that occasional surface-dressings were given, and the spade was never used over their roots. If such practices were well carried out we should hear much less fuss about stocks.

Let me here warn the amateurs against planting trees in the same soil, unimproved, that decayed trees have been removed from. They will seldom succeed. Whether it be on account of the exuviae of the former tree, or that certain qualities have been abstracted, I know not, probably from the two combined; but certain it is that the practice is bad. It is very easy to exchange such exhausted soil for that of some bed or border contiguous. Where soil is very hot and loose, I have several times used, and recommended, lumps of marl and clay to be placed on the impervious material which forms the base of the station. This serves to retain moisture during the summer droughts; and I have ever found, that under such circumstances, they cling to the fatty material with the utmost tenacity.

As before observed, surface-dressings are most important. I collect a huge heap of materials for this purpose every season, and

#### FLOWER FARMING IN SOUTHERN FRANCE.

CONSUL MASON of Marseilles, in a recent report upon flower farming in Southern France, says that the conditions of industrial success in flower growing can be best studied by a specific example, and he quotes the case of a plantation at Seillans in the department of the Var. This farm is about twenty-three acres in extent, and is situated on the southern slope of the hills, about 2000 feet above the level of the Mediterranean, and at a distance of twenty miles from the coast. The calcareous soil was originally naturally poor and thin, and the Olive trees which had occupied the ground for a century or more prior to 1881, yielded but scanty and unnecessary returns. The slope of the surface was so steep that the water of a spring which flows from the rocks above the track could be but imperfectly utilised for irrigation, and the land was regarded as practically worthless. In 1881 the proprietor caused the Olive trees to be removed and the land prepared for flower culture. The ground was dug up to the depth of 4 feet, the larger stones removed, and built into sustaining walls for the terraces into which the surface was divided and levelled. Along the upper margin of each terrace a shallow ditch was cut, connecting with transverse channels which supply the spring water for irrigation. The abruptness of the slope will be indicated by the fact that, on the tract of eighteen acres, the terrace walls required to produce a series of level or gently sloping surfaces are over 2000 yards in length. Thus terraced, the tract yielded

about seventeen acres of prepared ground for planting. In the autumn of 1881, 45,000 tufts of Violets and 140,000 roots of the white Jasmine were planted. The following spring the remainder of the ground was planted with Roses, Geraniums, Tuberoses, and Jonquils, and a laboratory erected for the manufacture of perfumes. The position proved to have been well chosen, as the flowers grew vigorously and well; and in 1885, the fourth year after planting, this farm, which had previously yielded a rental of £23 a year, produced perfumes valued at £8630, giving a net profit of £1553. This is sufficient to illustrate how lucrative flower farming may become in favourable districts and under good management.

From observation at Scillans and in the neighbourhood of Grasse, where perfume flower growing is the leading industry, Consul Mason says that the essential conditions appear to be an altitude of from 500 feet to 2000 feet. Flowers grown on such elevated positions are said to be richer in perfume than similar varieties which bloom in valleys and lowlands; a soil rich in calcareous elements, a situation sheltered from cold northern winds, and not subject to the white frosts which in spring and autumn affect the damp lowlands. In countries like Southern France, where the rainfall is always scanty, and often wanting entirely from May until September, irrigation is essential to the culture of flowers as well as every other crop. It is said the perfume growers and distillers on the Mediterranean coast attribute their success not less to the peculiar climate of Provence than to their knowledge of every detail of the industry—a knowledge acquired by more than a century of experience, and transmitted from generation to generation. One essential principle in perfume culture is that all fancy and "improved" varieties of flowers are discarded, and the natural, simple, old-fashioned kinds are exclusively grown. The Roses on the slopes of Scillans are the common pink ones, and the single wild Violet is preferred to all the larger artificially developed varieties. Only the white Jasmine is used; the yellow and less fragrant variety appearing to be either discarded or unknown. Jasmine plants are set in rows about 10 inches apart, and are closely pruned. Roses are grown on the lower terraces, and are also cut low, and the ground between the plants heavily manured. After the Roses have been gathered the stem is cut to within a few inches of the ground to preserve for the next season the entire vigour of the plant.

During the harvest season traders or "middle men" go through the country every day with waggons collecting flowers from the farms, for which they pay prices varying according to the extent of the crop and the demands of the market; their loads are hurried to the nearest manufacturer, and delivered while the flowers are still fresh and crisp. The flowers are usually gathered in the morning, as soon as possible after the dew of the preceding night have disappeared. The manufacture of perfumes includes the making of pomades and oils by the process of absorption, and of essences and essential oils by distillation. Every complete establishment is provided with apparatus for all these processes. Pomades are the commercial vehicles for absorbing and transporting the perfumes of the Jonquil, Tuberoses, Jasmine, and other species of flowers. A square frame or chassis of white wood, about 20 inches by 30 inches in size, is set with a pane of strong plate glass. On either side of the glass is spread a thin, even layer of grease—two parts lard to one of tallow—which has been purified and refined by previous boiling and straining. Thus prepared, the frames are piled up in ranks, 6 or 7 feet high, to await the season of each special flower. When the blossoms arrive, the petals are picked from the stem, and laid so as to cover the grease in each frame. These being again piled so as to rest upon their wooden edges, which fit closely together, there is formed a species of tight chambers, the floors and ceilings of which are of grease, exposed to the perfume of the flower leaves within; the grease absorbs the perfume, the spent flowers are removed daily, and fresh ones supplied, and this process goes on from two to four or five months, according to the desired strength of the pomade, which, when sufficiently charged with perfume, is taken from the glass with a wide thin spatula, and packed in tin cans or stagnons for export. By these methods the delicate odours of flowers are extracted, and retained for transport to distant markets, where the grease, being treated with alcohol, yields the perfume to that stronger vehicle, and produces the floral waters and extracts of commerce. Coarse pomades are made by boiling the flowers in the grease, and subjecting the residue to pressure. The spent pomades are used for toilet purposes, and in the manufacture of fine soaps. The process of preparing perfumed oils involves the same principle, except that instead of solid grease superfine olive oil is used. With this oil pieces of coarse cotton fabric are saturated, which are then spread upon wire netting framed in woollen chassis about 3 feet by 4 feet in size. The flowers are spread upon the saturated cloths, and the frames piled one upon another, so that the perfume of the flowers is absorbed, as in the previous process.

Essences and scents are produced by ordinary distillation, in which the flowers are boiled with water in large alembics; the vapour carries off the perfume, and is condensed in adjoining copper tanks. Some of the retorts used for this purpose are of sufficient size to receive at once half a ton of fresh flowers, with the requisite water for their distillation. When scents are to be produced alcohol is used in the distilling tank to receive the perfumes. By skilful combinations of the perfumes of the different flowers, sometimes with the addition of chemicals, a large variety of scents, such as "patchouli," "jockey club," &c., are produced at the original laboratory. The work of the manufactories is largely done by women, who earn from tenpence to one shilling for a day's labour of ten hours, and during the busy season of Roses and

Orange flowers they earn half as much more by working until midnight or even later.—(*Journal of the Society of Arts.*)



#### KITCHEN GARDEN.

**BETROOT.**—Frost is injurious to this, and the best of the roots should be taken in. It may be stored in any cool shed; loosen the soil in which the roots are growing with a fork, but do not break any of the root, then draw them up by the tops and trim off the latter at a distance of 4 inches from the crown. They may then be banked up amongst fine ashes in the shed, and if this is done when the roots are dry they will remain good without further attention until April or May next year.

**ONIONS.**—Those which were drawn up and taken under cover in the rough should now be cleaned of all loose skin and stored carefully away. We have tried many ways of storing Onions, and now we only follow one. This is, after cleaning they are spread out in a layer about 6 inches in thickness in a cool dry house, and there they remain sound and good until far into spring. We guard them from frost and never excite them with much heat. The plan of stringing Onions is good, but takes some time to accomplish, and except that it is a good way of showing the Onions it has no advantage over laying them out.

**TOMATOES.**—It has been a splendid season for Tomatoes in the open air. We never knew them do so well. They have been ripening for some months past, and now there are many still unripe on the plants. But these will not ripen much more now, and there is great danger of their being injured by frost. It is therefore best to cut the whole of them from the plants, tie them in clusters of ten or a dozen, and hang them in a warm room or glass house to ripen. We hang ours in a vinery. Fruits treated in this way do not become quite so good in flavour as those ripened under favourable circumstances on the plants, but they are by no means bad, and in fact they are very acceptable in the winter months. We have kept such fruits hanging until Christmas, and always try to store as many of them as possible.

**TOMATOES FROM CUTTINGS.**—All who wish to secure very early Tomatoes should propagate the plants from cuttings now. It will be seen that the old plants are bearing many young side shoots. These form excellent cuttings, and a quantity of them should be taken off and inserted singly in 2 or 3-inch pots. If placed in a light sandy soil and plunged in gentle bottom heat, they will root in a fortnight. They should then be kept quiet until about Christmas, when, if transferred into larger pots and placed in a gentle heat, they will soon grow and bear very early crops. Next spring we do not intend raising any Tomato plants from seed, but are preparing now to have a good number of rooted cuttings. We find them fruit sooner and more freely than seedlings.

**VEGETABLE MARROWS.**—The frost has cut down most of these plants, but there are still many fruits on them, and if these are cut off and stored in a dry room they will remain sound and fit for use for two or three months. They are very acceptable as other vegetables become scarce.

**LATE POTATOES.**—The crops of these are splendid. Our fears of second growth and other ailments have been unfounded, as the tubers are numerous, large, and clean, with little disease. Indeed our crops were never better, but they do not make any progress now; and the sooner they are all dug and stored the better. Do not disturb them when it is wet, but choose a fine day, dig them, and place them under cover; then they are safe, and can be picked over and finally stored. Their perfect keeping depends a great deal on dry storing.

**SPINACH.**—The last sowing is growing freely. The plants are inclined to become crowded, but to allow them to do this would be a mistake. Some may think that they will get a heavier crop from crowded plants, but the leaves of such will be very small, and it is large leaves that are most valuable. If the plants are thinned out to a distance of 6 inches apart they will produce a more satisfactory crop than if only grown 1 inch asunder.

**CAULIFLOWERS.**—Veitch's Autumn Giant is still fine. Many more are turning in than are required, but by cutting them before they are too old, trimming most of the leaves off, and then inserting the stems in boxes filled with sand or leaf soil, and placing them in a cool shed, they remain good for a month. Those which are formed, but not large enough for cutting, may be injured by frost if not slightly protected, and this may easily be done by breaking some of the large leaves half through and turning them down over the heads.

#### FRUIT FORCING.

**VINES.**—With so many good late varieties the necessity of forcing Vines to have ripe Grapes very early is no longer desirable where the late varieties are grown in sufficient quantity to afford a supply up to May. For long and good keeping without any deterioration of quality Lady Downe's is without a rival, keeping fresh and plump until May. It is also a certain cropper, and though not so imposing in appearance as some it forms compact bunches, which finish in less time and invariably better than the larger berried varieties. Mrs. Pinec comes next in respect of keeping, and in quality is superior; indeed, it has



the advantage of flavour over any late Grapes, but it requires more heat and time to finish it satisfactorily than Lady Downe's. We have it in a house started in February with the berries black as jet to the stalk, and the quality equal to Black Muscat. Alicante, started in good time so as to finish not later than the middle of September, is capital in crop and appearance through size of bunch and finish. Gros Colman is perhaps the most profitable of Grapes to grow for a market supply. It is magnificent in appearance, the berries being splendid, the bunches compact, and it is an enormous cropper. The latter property is often taken advantage of to the injury of the crop in finish. It requires more time than any other Grape, and should be started early so as to have August and September to finish in. Gros Guillaume also requires a long time to colour and ripen thoroughly. It is not so compact in bunch as Gros Colman, but is larger, and on that account is very often over-cropped, in which case it is a poor Grape, as it is not even sweet, and is most unsatisfactory for keeping through the softness of its footstalks. If grown well Gros Guillaume is anything but coarse or inferior in flavour. Trebbiano when thoroughly ripened is good in flavour; and Syrian is by no means despicable, nor is Calabrian Raisin. All points considered we prefer them in the order given. The only other deserving of note is Alnwick Seedling, an excellent Grape. West's St. Peter's is too small in bunch for our modern ideas of a late Grape, otherwise it is an excellent table variety.

Where late Grapes are not cultivated in quantity to maintain a supply to May preparations must be made for early forcing. The Vines having been pruned in September, the loose bark stripped off, the house may be cleansed, the border top-dressed, and the Vines dressed with a solution of softsoap, half pound to a gallon of water, brought to the consistency of cream with flowers of sulphur, adding, if there have been any scale, half a gill of spirits of turpentine, the composition being equally effective against mealy bug, killing all it touches. The whole being in readiness as advised in former calendars, cover the outside border with leaves and stable litter, so as to warm the border preparatory to applying fire heat. If there be the convenience for making up a good bed inside the house of Oak or Beech leaves, with about a third of stable litter, it will greatly facilitate the Vines breaking, and be more beneficial to them than fire heat alone, therefore have them in readiness for placing in the house at the early part of next month. Vines, however, to produce ripe fruit in late March or early April are best grown in pots, as stated a former calendar, selecting early sorts, such as Buckland Sweet-water, Foster's Seedling, and White Frontignan in white Grapes; and of black, Black Hamburg, Mill Hill Hamburg, Royal Ascot, and Madresfield Court. They should now be in position preparatory to starting them early next month.

**Renovating Vine Borders.**—There is no doubt that Vines thrive for an almost indefinite period in a soil suited to their requirements, and where they have a good extent of rooting area, as may be seen in many places where the Vines were originally planted to cover a large area. Vines mostly past have their roots confined to limited areas, and the natural outcome is that the soil becomes less favourable as a rooting medium if not defective in aliment, hence the desirability of renewing the soil or such portion of it as will secure as many active feeders as possible. There is probably nothing equal to fresh soil as an encourager of Vine roots.

Where Vines are unsatisfactory no time should be lost as soon as the leaves have effected their functions to the extent of perfecting the buds and wood, and whilst they are still upon the Vines, in removing the soil down to the roots and picking it from amongst them, so as to displace as much of it as possible with fresh. In the case of the border being very unsatisfactory and the roots few and deep, it will be necessary to remove all the soil and renew the whole border, commencing with the drainage, which should be clear 9 inches to 1 foot thick, having a layer of fine material at the top, nothing answering better than old mortar rubbish, a 3-inch thickness over 9 inches of brickbats, &c. The drainage must have a tile drain under to carry off the superfluous water. Two feet depth of soil is ample, and the roots should be laid out evenly in the top foot, encouraging those from the collar by laying any that proceed therefrom only just beneath the surface. The whole should be made firm, and the compost moderately dry. If the roots are inside and outside, one part may be done one year, and the other the next without any danger of loss of crop, care being taken to preserve all the roots possible, and to keep them from the drying influences of the atmosphere whilst the work is in progress. Muleh the surface with a little short material, preferably fresh horse droppings, and cover outside borders with a good thickness of leaves or other protective material. As regards soil good turfy loam is best, but any ameliorated soil will grow good Grapes. Preference should be given to medium textured soil, that overlying clay being better than that overlying sand. The most suitable is a rather strong loam overlying the limestone formations and interspersed with flints.

#### PLANT HOUSES.

**Begonias.**—Such Begonias as *manicata* and *hydrocotylifolia* must be removed from cold frames, for they are too damp for them, and if allowed to remain much longer their large foliage will be injured. They will do very well for some time in a cool house provided the air is kept dry and the plants watered with care. While under these conditions they should be kept rather dry, but not to such an extent as to injure their roots. No more water should be thrown about the house than is necessary when the plants are watered, which should be done in the morning. After a spell of dull days it may be necessary to use a little fire heat in order to expel moisture from the atmosphere.

**Celosias.**—The majority of the stock prepared for autumn and early winter decoration will be sturdy plants with their plumes well developed, unless they have been hurried in their last stages. When necessary to push them forward in heat they soon run up tall, and are soft, which necessitates great care when they are removed to cooler quarters. Plants in this condition must be screened from cold draughts, or their foliage will fail, and if overwatered they quickly damp off. Those brought forward under cool conditions are far less liable to suffer from damp. These will be safe in any structure where the night temperature does not fall below 50°. When they require water apply it only in a tepid state. If any of these plants are in a backward condition, grow them close to the glass in a temperature of 60°, with a good circulation of air day and night, which will prevent their lengthening too quickly.

**Cyclamen.**—Where it is necessary to keep these plants in cold frames for some time longer they must be wintered with care and freely ventilated, or the foliage is liable to become spotted, and the flower buds to damp off. Where practicable remove them to a light airy structure, where the atmospheric conditions can be regulated to suit them. The main stock of these plants will not require any artificial heat for some time to come. If a few plants are required in flower, remove the most forward to a shelf close to the glass, where a temperature of 55° is maintained. Give a little air day and night to prevent the foliage drawing. Water carefully, but do not allow them to suffer by an insufficient supply. Weak stimulants may be given to all that have filled their pots with roots.

**Heliotropes.**—Plants that have been grown outside and housed some time ago will soon come into flower in a temperature of 55° to 60°. If they are to continue flowering they must be kept in the latter to keep them growing; if they once cease growing they will also cease flowering. Place young plants that are now rooted into 3-inch pots, and grow them on a shelf for a time in an intermediate temperature until they are well established, then harden them, and place on a shelf where the temperature is about 45° at night. Cuttings for early spring flowering may still be rooted, but they must be encouraged to grow until they have formed three or four shoots.

**Petunias.**—Petunias established in small pots before the winter are invaluable for flowering early in the season for conservatory decoration. Cuttings rooted now and left in the cutting pots will yield plenty of good cuttings early in the season for succession, and are much better and easier managed than old plants.

**Fuchsias.**—Those that have flowered may be gradually dried and placed in a cool airy house to rest; a shed will do very well. Others that have been outside for some weeks since they ceased flowering may be dried and given the same position. Do not store them away in a wet condition. Place those that were rooted some time ago into 3-inch pots, and store them on a shelf where they can be kept slowly moving during the winter. Others just rooted may be placed into thumbs, and when established give the same position as for those in 3-inch pots.

**Zonal Pelargoniums.**—Place those rooted towards the end of July, and that have since been pinched, into 5-inch pots. Pot them firmly to prevent a soft growth, and place them on the greenhouse shelf for the present. Water carefully until well established, and then keep them on the dry side until the end of the year. They must be kept until practically at a standstill, but rather encourage them to grow slowly than allow them to go back by too low a temperature and too much water.

**Shading.**—All shading should now be removed, the blinds being taken off the houses, dried, and stored for the winter. The shading that has been employed over Ferns and cool Orchids will not be needed any longer. This year we have gradually dispensed with the shading much earlier than usual, and the plants look better for the admission of more light. Where a good number of blinds are employed these should be labelled, stating to which house they belong and the side they are arranged for. This saves confusion when they are wanted again.

**Protection for Chrysanthemums.**—Where an attempt is made to have the flowers of these plants during January and February, it is important that they be left outside as long as possible. To insure their safety they must be protected from frost. Any rude lean-to or span-roofed structure will answer the purpose well. The pots may be plunged to keep them from being knocked in all directions by heavy winds. The sides of the structure can be protected with mats, and the top with canvas blinds. The latter can be drawn up early on fine mornings and the mats removed. During severe stormy weather they can be kept on. This light protection will be ample to protect them from injury until near Christmas, unless severe weather sets in exceptionally early. In some seasons they can be kept outside very late without the slightest protection, but one frost may upset the whole work of the season, and therefore it is necessary that provision for their protection should be made. It should not be used until an occasion arises. When the whole or nearly the whole of the plants are placed inside at one time the majority are in flower all at once, and do not therefore prove so useful as if brought forward in batches according to the demand. With attention in this respect there is no difficulty in having a supply of these flowers until the middle or end of February. Place some at once where they can have tiffany placed over them at night in case of frost; it will be found that many of the plants can be kept outside fully a month or six weeks longer. This will make at least two or three weeks' difference in the time of flowering.

#### THE FLOWER GARDEN AND PLEASURE GROUND.

**Clearing the Beds.**—We have experienced sharp frosts much earlier than last year; then we had Dahlias, Begonias, Gaillardias, Pelargo-



niums, and various other plants flowering freely fully a month later than will be the case this year, and even Chrysanthemums are badly injured by the frosts. This early destruction of the more delicate bedding plants will not be without its compensating effects. The beds must be cleared at once, and this will admit of their being refilled before November is reached. Where few cuttings of Zonal Pelargoniums were taken it is advisable to winter as many of the old plants as possible. All should be forked out of the soil, have all dead blooms and the greater portion of the old leaves picked off, and the roots lightly shortened prior to storing them thickly in boxes, pots, or beds of soil in heated pits. The delicate variegated sorts keep best in pots, and they may be either packed thickly in 6-inch pots or be placed singly in 3-inch pots. Any loamy soil will do, and they should be potted firmly. No water must be given to any of them, and they must be protected from both damp and frost. Abutilons and Veronicas, Grevilleas and Acacias may be lifted with a small ball of soil about the roots, potted and placed in a greenhouse or conservatory. Polemoniums, Centaureas, and Cinerarias, after being potted, may be wintered in a cold dry frame.

Succulents, notably *Echeveria metallica* and *metallica glauca*, *Pachyphytums*, *Kleinia repens*, and *Sempervivum arboreum*, are crippled. These must be potted and stored in a dry pit or greenhouse, and require little or no water. The *Kleinias* may be packed thickly in ordinary bedding Pelargonium boxes. *Sempervivum californicum* is quite hardy, but *Echeveria secunda glauca* is not, and during most winters requires protection. They may either be bound to stakes after the manner Onions are stored, and hung up in a greenhouse or vinery, or be packed away as thickly as possible in temporary pits or frames, and, in addition to the lights, be further protected with litter or mats during the prevalence of a very severe frost. They are also frequently wintered successfully packed over the surface of, sloping mounds of soil formed against a sheltered wall. Even in these positions they require to be covered with mats occasionally, or snow and frosts together will cripple them. Choice *Gladioli* must be lifted, dried under glass, and then packed in boxes of dry sand.

Dahlias should have the stems shortened to about 9 inches in length, lifted without injuring the tubers, and after being well dried to be packed closely on a dry floor of a shed or cool and light cellar, covering them with a little dry soil. The least valued sorts, including many singles, are frequently left in the ground all the winter, and if well protected with a mound of ashes they usually survive. *Salvia patens* may be lifted, and either treated similarly to the Dahlias or be stored closely in shallow boxes of fine mould. Tuberous *Begonias* should not have the soil too closely removed from them, but after being slightly dried may be packed thickly in boxes of fine mould and kept through the winter in a cool room or shed, taking care, however, to well protect them from severe frosts. The roots of *Verbena venosa* can be most surely preserved by lifting and packing closely in boxes of fine mould, this being just moist enough to keep them plump. It is these roots, preserved in a cold frame or shed, that are best adapted for propagation next spring. Cannas may be lifted in large clumps, partially cleared of soil, and then either stored in a dry cellar or under a greenhouse stage. These and various bulbous or tuberous plants are frequently stored under a greenhouse stage only to be damaged or killed by drip and too much moisture. If this method of keeping any kind of dormant plants must be resorted to, see that some provision is made for keeping them much drier than is usually the case in such positions.

**Refilling the Beds.**—Up to this time little rain has fallen, and the ground has been too dry for the usual methods of transplanting the Forget-me-nots, Silenes, Wallflowers, Primulas, and various annuals and shrubs. All when so very dry ought to be well watered a few hours prior to lifting, or the chances are little or no soil will be retained with the roots. They need to be carefully transplanted, well and firmly replanted, and should the soil be at all dry well watered. These, even more than some of the summer bedding plants, require fairly rich soil, and a little manure may be added to those beds that have not received any lately. As bulbs alone do not long beautify the beds the best course is to mix these with the flowering plants, and they may be inserted at once. Hyacinths are very effective when disposed about 12 inches apart and 4 inches deep, one or at the most two colours being employed in each bed. Tulips may be inserted from 4 inches to 6 inches apart and 3 inches deep, and in separate colours as much as possible. Narcissi may be given the same room as the Hyacinths. Crocuses to be either planted in small patches of different colours, or in lines, the bulbs being placed about 2 inches apart and 4 inches deep. Snowdrops also look well in patches, or they be otherwise treated similarly to Crocuses. Plant Scillas near the edges, about 2 inches apart and not less than 3 inches deep. Now is a good time to plant the Irises, notably the lovely Spanish section. If these are planted about 6 inches deep in well worked fresh loamy soil they may remain undisturbed, and will do well for several seasons, large clumps forming where each one was planted. The surface of the bed may be planted thinly with spring and summer-flowering plants. The Grape Hyacinth should also be planted deeply and not often disturbed. Fritillarias are suitable for the backgrounds of borders where they will not often be disturbed. Plant the bulbs at once, surrounding each with a little silver sand and cover with about 3 inches of soil. Dodecatheons (American Cowslips), *Eranthis* (Winter Aconite), and *Erythroniums* (Dog's-tooth Violets) are all best planted where they are not often disturbed. A peaty soil suits them, and a little sand should be placed about the bulbs. Anemones may be planted now if an early display is desired for flowering late in the spring; February is soon enough to plant. These again thrive much

more satisfactorily if left undisturbed in the ground. They delight in good loamy and well-drained soil, and may be planted in drills drawn about 5 inches apart and 3 inches deep, disposing the tubers about 5 inches apart, and cover with a good sandy soil. *Triteleias* may be planted now, and these again we prefer to place in patches, where they may remain a long time undisturbed. *Ranunculuses* if planted now would most likely perish during the winter, and January is quite early enough to place these in the ground.

## THE BEE-KEEPER.

### HINTS FOR BEGINNERS.

#### PREPARING FOR NEXT SUMMER.

THERE is, perhaps, no better time than the present to tell young bee-keepers what should be done to insure success next summer, and my advice is what I put into practice myself. After making sure that all hives are in a proper state to defend the bees from wet and the inclemency of the winter, it is imperative that all stocks should have young and fertile queens, with ample bees. I cannot advise anyone to keep weak stocks, although a large percentage of my own have not more than about 1 lb. of bees or little more, and I have every hope that these will turn out profitable stocks next summer as in bygone years. But I recommend bee-keepers to be careful that the bees are well provided with plenty of stores and in full sized hives of worker comb, or having but little of drone comb. However much we recognise the usefulness of drones under certain conditions we also know how they deter in others, therefore the wisest course is not to induce the breeding of too many drones.

With the exception of my stocks kept for rearing queens, all others are nuclei of the present year, vigorous and healthy but not numerous, occupying from 248 cubic inches up to 1000. I have added to all these nuclei sufficient combs filling three divisions of the tiering hive. These combs contain sufficient honey and pollen to carry the bees successfully through the winter and far into spring, by which time they will be greatly increased in numbers and in a fair way towards crowding the hive, and ready to store surplus honey when the first flow commences during April and May. The conditions under which my hives now stand are favourable for preserving the bees during the most trying weather, while breeding, when once started, will go on uninterruptedly till the close of another season.

The great weight my hives reach in good seasons is entirely due to the autumn preparation as described above, and not to any manipulation whatever during winter or spring. Amongst all the hives I have broken up this autumn I have not observed a single unhatched foul cell, and very few unsealed cells of honey, also due to the mode of management, and particularly to the mode of ventilation. "Foul brood" is a preventable disease, and no means which tends to prevent the plague should be neglected.

#### SWARMS GREAT IN NUMBERS.

Whatever inexperienced persons urge in favour of small hives or bees that cannot produce great numbers the beginner should disregard. It is from prolific queens and large hives only that large quantities of honey can be taken. I am of the opinion that some of my hives during the height of the season would contain a hundred thousand bees, even so far on as the 7th October, that being about the earliest I was able to attend personally and take the bees from my heaviest hives. Some swarms of the current year contained as many as 12 lbs. of bees,

and these were not gorged with honey either, having been shaken from the combs before they had time to fill themselves. One of these swarms, less a third of the number, was sent to a gentleman in England, who received them the following day they were taken from the hive in a semi-dormant state from hunger, but all were reencituated, and were styled by him as "a fine lot of bees." A third of the whole number was formed into a fine stock with a pure Syrian queen at their head, for the purposes of amusement and experiment next summer. That queen is now the fourth generation from the first imported, I expect that by-and-by the climate will have the effect of smoothing the temper and making more hardy that beautiful and industrious race of bees. Having Carniolians to winter with her will insure her usefulness next year.

However great the advantage may be of having strong swarms at this season, there can be no doubt but that medium, and very often weaklings in autumn, are the most profitable during the following summer, and beginners will do well to study, experiment, and find out the happy medium strength a stock should be. I then ask the question, What good would have accrued to me by joining two 12-lb. lots of bees and putting them into one hive at this season? I have an opinion on the strength a colony of bees should be now in this country as well as what they should be in one having a much lower temperature, but shall be glad for further information from anyone capable of answering, without prejudice as to the saving of condemned bees.

#### SWARMING VERSUS NON-SWARMING.

This subject has from time to time received a great deal of attention, and different opinions have been expressed thereon. To answer definitely which is the best system without allowances for season and locality would be committing an error unjustifiable in all its aspects, as under certain circumstances the one is as good as the other, and that which may be the most profitable one season may not be so the next. With the exception of breeding stocks I keep my bees on the non-swarming principle, and I am as often as not rewarded with swarms from almost every hive. To have full control and prevent bees swarming is an impossibility. We use the means to prevent it, and often, owing to the shortness of the honey season, so protract or delay swarming that the bees by instinct change their intentions, thereby preventing utter ruin to themselves.

Of all the plans contrived to prevent swarming none is reliable. The nearest approach to it is a full sized hive with little drone comb; a young, fertile, and prolific queen; ample super room in advance of their wants; shade and ventilation during hot weather. Where the former is wanting a wet blanket wrapped round the hive will keep the bees cool and at work. In order to show that neither ekes nor space in front nor supers prevent swarming, I will cite the following cases, and I could adduce hundreds of similar ones. I have two full-sized hives that have a ninth part of their hive beneath empty, never having been combed, and yet, with the addition of unfilled supers, swarmed for three years in succession. The first hive that swarmed this year occupied one-half of its hive only, although it had its under box and filled with foundation; several swarmed five days after being hived, while the space they occupied was not half filled. Two hives having young unfertilised queens and without eggs, had a spare queen caged on the top of their hives, and immediately both swarmed, but in neither case did the queen leave. When the caged queens were

removed swarming ceased, but when restored again they swarmed. Just as the caged queen was left or removed did the bees swarm or settle, and not in one instance did the queen leave with the bees. Space will not permit to detail further the swarming propensities of bees, while to the beginner no good would accrue.

As I have stated, I keep my bees on the non-swarming system as far as I am able, but do not care whether they swarm or not providing they do not do so before they are in full strength; then a swarm is as good as any non-swarmers need be, provided all or a portion of the unfilled supers from the old stock are given to it, and all the better if a portion of the brood combs too find their way to the swarm. Care must be taken not to allow the swarm to build much drone comb, because if the honey season is a long one it will be liable to swarm again, particularly at the Heather.

When a non-swarmers throws a swarm unexpectedly, after dealing with the swarm as advised above, no time should be lost in providing the old stock with a fertile queen after excising all royal cells and surplus sealed honeycomb, and all empty space must be filled with comb foundation. Where Heather is available this should be attended to, and if the weather is unfavourable for honey gathering, a little feed should be given to encourage breeding. This is seldom necessary, but should not be neglected when honey is scarce, as breeding stopped in July means no honey from the Heather.

#### COMB FOUNDATION.

I have before hinted at the desirability of having all comb foundation made from genuine native wax only, as well as to have all honey of the first quality that is meant for consumption. By having the former good depends greatly what the latter will be.

Much of the foundation made from foreign wax that I have seen this year would not be used by me under any consideration; it is so soft and simply abominable, some of it so much so that honey stored in it after being extended was uneatable and incited nausea and vomiting. My attention has been drawn to several cases of the kind, the honey tasting of rancid grease or of castor oil. A bee-keeper informs me that three hives he purchased fitted with comb foundation, after it was drawn out, filled, and sealed by the bees was of the same disgusting nature, while a fourth hive filled with foundation made from native wax, the honeycomb was splendid. So careful am I of having my honey of first quality I do not even use wax made from combs that were originally built from foreign wax. Other subjects of importance to beginners will be treated upon as the season advances, but we may caution them to beware of being entrapped into purchasing articles unsuitable or unnecessary through testimonials from mere novices.—A LANARKSHIRE BEE-KEEPER.

#### THE PAST HONEY SEASON IN HALLAMSHIRE. SKEPS AHEAD.

THE past season on the whole has been quite satisfactory to all who use large hives worked in a proper manner, while those who use small ones and follow the teaching of the "B. B. J." declare the season a complete failure on account of the drought and consequent failure of the Clover in July.

April was a grand month, the weather fine and warm, causing queens to breed heavily. May was damp and very cold, which caught those who had spread brood, completely ruining many fine stocks; while those left alone, with plenty of food left over winter, duly hatched out all the April-laid eggs, and which gathered in the June honey flow.

June began grandly and yielded honey in profusion from Apples, Sycamores, and Raspberries, and in the last week from White

Clover. Swarms during the first week hived in large skeps, and therefore were not helped with foundation, had from 40 lbs. to 80 lbs. of honey, and casts in the second and third week had from 10 lbs. to 20 lbs., while old stock hives had fully sufficient to last them till next June. These figures apply chiefly to skeps and native black bees too, and as I had most of the swarms and casts for driving, the contents (honey and wax) were nett profit.

Bar-frame hives did not come up so well, although they were worked on the non-swarmer system, the reason of this being they are colder than skeps. They did not mature so many of the April-laid eggs, therefore they were not at all equal in numbers of bees with skeps, and only yielded from 40 lbs. to 50 lbs. surplus. Had July been the best honey month as usual, what with empty combs and the extractor, no doubt frame hives would have left the skeps behind. The bees of those pupils of the "B. B. J." were beginning to approach swarming condition at the end of the month—hives being quite full of brood—when they put on the supers, expecting with such hot weather the greatest Clover honey harvest known, but a month's cloudless sky had dried the ground around of all honey-producing plants. Thus it continued, no rain, no honey, the bees doing nothing but soiling combs with propolis until August 15th, at which date I had fully given up all thoughts of getting any Heather honey, as the moors were in full bloom and no bees working. Then it began to rain a little day by day till the 20th, when it had soaked into the dust-like soil about 4 inches. In the evening the glass began to go up and so did my hopes, for I began to make all at home safe for travelling to the Heather, which was not completed until the church clocks had chimed Sunday morning (the 21st). The afternoon being more promising, I took a walk to see those stocks which had been at the Heather all August, and found them bringing in a little Heather honey. Monday, the 22nd, I hired a dray for the evening to take the whole, and when I went to secure the entrances I found them returning in clouds from the moors loaded with Heather honey. The moors are fully five miles from my apiary to its nearest edge, and the bees had to make a rise of over 500 feet. This is no new experience with me, as every time the Heather has yielded in profusion for years all bees within six miles have brought in Heather honey during settled days. The "B. B. J." has lately been preaching that bees never travel more than two miles, and it has quoted numbers of authorities (?) to prove, or rather support, their assertion. One correspondent and the editor advises setting bees down right in the midst of the Heather. Just remember that the moors are practically roadless. I formerly used to put them down on its edge, but never again shall I do it. I now with more experience (dearly bought) place them a mile at least from it, and give them also a rise of nearly 500 feet. The reason I do so I intend to explain fully in another article. This enables me to visit them by train. I can go there and back before breakfast.

But to return. I safely took the bees as soon as they had settled, and placed them four miles nearer in about a straight line between the apiary and the moors. Judge of my surprise on visiting the apiary next morning to find many thousands of bees flying about loaded with Heather honey. They were taken four miles at midnight, then they had another mile to fly to the moors, and from there they found their way back five to six miles. Some of the "B. B. J." people will perhaps explain this on their two-mile theory. Bees had returned from all stocks except pure Cyprians (I had no pure Syrians at the time), native blacks, Carniolians, Syrian hybrids, and Punic. I procured a queen, fixed up an empty hive, put in the queen, and all the bees began to collect and settle in it, and at night I found they were equal to a big swarm, and day after day they worked to and from the moors. The fine weather lasted just seven days, during which time the bees quite filled all their combs with honey. I never saw Heather honey so thick when freshly gathered, or combs so quickly filled. One stock of Syrian—black hybrids, first cross, and which I have always regarded as the best kind of bees for extracted honey—increased in weight over 60 lbs. This was when I brought them home, and as they had reared a lot of brood, no doubt they made 10 lbs. per day. Cyprians pure did very well, so did Carniolians. Taking into consideration their strength; a small stock of Punic bees, which seem to be pure, though I thought at first they were hybrid—the queen was one of this year's and mated in a nucleus of native bees, some may have been left (aged and of a dark colour)—has gathered the most honey and bred the most young bees for winter. I found all brood hatched on September 30th. Last year the old queen was laying heavily on November 9th. This race, I believe, will take the lead in all apiaries not worked for comb honey; for which purpose Carniolians will beat them, as they use so much propolis, causing the combs to have a dirty appearance. This makes them tougher, and is an advantage when worked for extracted. I have previously pointed out the extraordinary hardiness of this race of bees. Whether their

extra honey-collecting qualities result from this peculiarity, resulting in fewer bees being chilled to death when out from home, or longer lived, or their great determination to have honey whenever possible, I have not yet determined; probably all three qualities have to do with it.

One peculiarity of the season has been the total absence of black honey in the hives. Some say it is "honeydew." I have always affirmed it to be Blackberry honey, which I determined by catching and dissecting the bees working on that kind of blossom. This year Limes, Maples, Oaks, and Black Currants have been covered with it, yet bees preferred to starve rather than collect a bit, while the Blackberries failed along with Limes to yield honey on account of the drought. I have never seen bees collecting honeydew, and surely they had every inducement to do so the past season. Those who still think the black honey comes from it will oblige by accounting for its absence this year.

Bees generally are in good order for winter without feeding, except late swarms upwards of six miles off the Heather; all within that distance are in splendid order as regards bees and honey. Most have learned a sharp lesson to use larger hives in future, nor do skepists feel inclined to adopt the frame hive, for they certainly have reaped by far and away the greatest rate of profit on capital and labour, proving much what the late Mr. Pettigrew so ably taught in these columns.—A HALLAMSHIRE BEE-KEEPER.

#### TRADE CATALOGUES RECEIVED.

James Dickson and Sons, Newton Nurseries, Chester.—*Select Roses*, 1887 8.

E. P. Dixon and Sons, Hull.—*Catalogue of Roses, Trees, and Shrubs*.

L. Späth, Berlin.—*General Catalogue*.



## TO CORRESPONDENTS

\* \* All correspondence should be directed either to "THE EDITOR" or to "THE PUBLISHER." Letters addressed to Dr. Hogg or members of the staff often remain unopened unavoidably. We request that no one will write privately to any of our correspondents, as doing so subjects them to unjustifiable trouble and expense.

Correspondents should not mix up on the same sheet questions relating to Gardening and those on Bee subjects, and should never send more than two or three questions at once. All articles intended for insertion should be written on one side of the paper only. We cannot reply to questions through the post, and we do not undertake to return rejected communications.

**NAMING FRUIT.**—The attention of senders of fruit to be named, is respectfully directed to the intimation near the foot of page 351.

**The Horticultural Benefit Society (A Member).**—We had seen the report to which you direct our attention. It was undoubtedly taken from our columns but reproduced fully and in that respect fairly, and we make no complaint if it served a good purpose, and will assist a good cause.

**Dendrobium Dalhousianum (A. W.).**—It is doubtful if you will succeed in inducing the plant to flower so much earlier than its usual time without a season or two's preparation. Endeavour to ripen the growth by full exposure to light, rest the plant in a cooler house, and then introduce it to heat. The flowers are produced on the old pseudo bulbs which you apparently refer to as spikes. By promoting an early growth and ripening you may cause the plant to flower earlier than usual, but scarcely to the extent you anticipate.

**Age When Seeds Cease to Germinate (W. D.).**—There is a long list in Johnson's "Science and Practice of Gardening." We extract the following from it:—"One year: Peas, Beans, Kidney Beans, Carrot, Parsnip, Orache, Herb-Patience, Rhubarb, Elm, Poplar, and Willow. Two years: Radish, Salsafy, Scorzonera, Purslane, the Alliums, Cardoon, Rampion, Ali-ander, Love Apple, Capsicum, Egg-plant. Three years: Seakale, Artichoke, Lettuce, Marigold, Rue, Rosemary. Four years: Brassicas, Skirret, Spinach, Asparagus, Endive, Mustard, Tarragon, Borage. Five and six years: Burnet, Sorrel, Parsley, Dill, Fennel, Chervil, Hyssop. Ten years: Beet, Celery, Pomplion, Cucumber, Melon."

**Caterpillars on Ash (G. S. Balfour).**—The caterpillars sent are those of the dusky Thorn, *Ennomos fuscantaria*, a rather local species of moth. They had evidently placed themselves under the bark in order to form their cocoons, in which they would remain as quiet through the winter, the moths appearing during the summer. It is not generally found on any tree except the Ash of which the caterpillars eat the leaves, cutting roundish holes in them, but seldom occurring in any abundance. Sprinkling soot freely about the roots has been serviceable, and watering with tobacco



liquor in the evening, but gas lime applied in a ring around the trees is one of the best remedies. The lime, however, must have been exposed to the air for a time, or it may be injurious to vegetation.

**Destructive Caterpillars (*W. B. Cork*).**—These are the half-grown caterpillars of the great yellow underwing, *Tryphæna pronuba*, which has been abundant in many parts of England this autumn, though it is every season more or less troublesome to gardeners and farmers. It feeds from early autumn to spring, unless the weather be severe, and varies its operations by attacking the roots during the day, and then issues from the soil at night to gnaw the crowns or stems of plants. Gas lime, at the rate of 2 ozs. or 3 ozs. to the square yard, pointed in at the least a month before sowing or planting, is an excellent grub antidote, but injurious to crops if used in excess or at the time of inserting the plants. It should be well mixed with the soil near the surface.

**Oil on Hot-water Pipes (*Malvern*).**—You ask us "what oil we recommend to be applied to hot-water pipes against mildew," also observe that you "had not heard of Mr. Veitch's remedy before." Our reply is, we did not recommend any kind of oil; but as is stated on page 321, the paragraph referred to was extracted from the "American Gardeners' Monthly" as "suggestive." We may also add that the Mr. Veitch referred to is not the respected head of the great firm at Chelsea, but an American authority of repute. Petroleum is referred to as oil in America, but we are not in a position to state whether that is the kind advised in our Transatlantic cotemporary or not. Perhaps we shall hear more on the subject, and in the meantime it will be safe for those who may try the oil vapour remedy to proceed cautiously and experimentally.

**Pear Trees Unhealthy (*Amos*).**—Judging from the spur sent we suspect the cause of the unhealthiness of your trees to be ungenial and possibly water-logged soil. If the soil is wet drain it thoroughly to a depth of 3 feet, having a clear outlet for the water. If the subsoil is not wet, then the condition of your trees is attributable to poverty of the soil. The remedy in this case is to remove the surface soil, just barcing the roots, and cover them with the best soil you can obtain, and over the soil place a good covering of rich manure. Limewash the trees, or, what is equivalent, dust them with dry lime when the branches are wet. If blossom buds predominate over wood buds remove some of the former, especially taking off any at the tips of the branches. Your aim must be to induce clean healthy young shoots, not permitting the trees to blossom profusely, and your trees will regain their vigour.

**Rose Heps (*T. R. B.*).**—These are not in any way injured by remaining on the trees to be frozen to some extent, indeed it is questionable if severe frosts are detrimental to their germination. Gather them when ripe, open them and store the seeds in damp cocoa-nut fibre refuse or leaf mould till spring. They may be sown either in pots or boxes in a frame on a mild hotbed, or in drills in the open ground in March. Artificial heat accelerates germination, but as the first essential of the Rose is hardiness some raisers sow in the open, on the assumption that only seedlings that prove their undoubted hardiness are reliable for propagation. Some of the seeds are often slow in germinating, therefore there must be no undue haste in disturbing the beds, or withholding water from pots or boxes in which the seeds have been sown. As you do not state your conveniences for raising the plants a choice of methods is given. Cover the seeds an inch deep and keep the soil uniformly moist by shading to arrest evaporation, and watering to supply moisture as it may be required.

**Tomatoes (*H. W. G.*).**—The disease attacking the stem of the plant is almost certainly due to over-feeding, more sap being provided than the leaves could assimilate, hence a case is produced analogous with blood poisoning. The same mistake of growing the plants in a large bulk of rich soil, or giving them liquid manure or active stimulants in some other form in excess, predisposes the leaves to the attacks of fungus, inasmuch as the peculiar and unhealthy state of the sap is favourable for the germination of the spores. The fungus is allied to that which attacks Potatoes under similar conditions, especially when the weather is dull and wet, checking transpiration and the elaboration of the sap. A close damp atmosphere should, therefore, be avoided for Tomatoes, as well as guarding against over-stimulating the plants with manure. A peck of soil, if of the right kind, is sufficient for a Tomato plant, if sufficient water is afforded in hot weather when the plants are in full growth. We have seen a splendid crop on plants this year that were planted 18 inches apart in a trough 9 inches wide and deep, the plants being confined to one stem; and we have seen plants in 9-inch pots roped with fruit to a height of 14 feet. The plants, of which portions are before us, have been treated too generously, and the atmosphere of the house has not been in the best state for keeping them healthy.

**The Mirabelle Plum (*S. Edwards*).**—So far from being useless, this Plum is highly appreciated by some persons. The late Mr. Rivers liked it and recommended it in the following words:—"For very many years I have admired this charming little Plum, and have often felt surprised that it is so seldom cultivated in England. It is not to be thought of as a dessert Plum, for uncooked it is rather dry, with a dull sweetness and of no taking flavour, but when cooked or made into jam its flavour is delicious; and what is very remarkable, although there are hundreds of varieties of Plums, not one has the peculiar aroma of this sort. If bottled (without water), the flavour is fully preserved, and a tart or pudding of Mirabelle Plums at this season is a real treat. Some years since, when Louis Philippe was king, I happened to visit the *potagerie* at Versailles, and there to my surprise I saw scores of baskets of this sort of Plum gathered ready for the Royal kitchen. On inquiry I found it was the favourite Plum of the Royal Family, no other variety equalling it in flavour for compôtes, &c. I afterwards learned that in the east of France it was equally esteemed, as it is now—it is, in fact, called Mirabelle de Metz. Its small oval fruit, bright yellow mottled with red, are most ornamental on the trees, and its stone the smallest of all Plum stones. The tree is best cultivated as a bush, and when in blossom should have a covering of light flannel when the nights are frosty. It requires a dry warm situation, and is well worthy of extra care."

**Roses in Pots (*Duncan*).**—Successful growers of Roses in pots repot them every year, not necessarily in larger pots if the plants are already large and the accommodation for growing them limited, but that they may make new roots, and receive a greater amount of good food during the

summer that is so essential for producing fine flowers in the following spring. The best time for potting Roses is in the month of June, directly after they have finished blooming, using a compost of two-thirds of good turfy loam and a third of well decayed manure, Tea Roses having the addition of a little leaf soil and sand. By repotting them at that period the new roots take kindly to the soil, which enables the plants to make good growths early, that become hard and ripe before the summer is ended. After potting they should be plunged in an open situation, and a thick coating of manure placed around and over the surface of the pots, so that the roots are kept cool, and the rains wash in the properties of the manure. Roses in pots are often spoiled through neglect during the summer, which is the season they should receive the most attention. You would not reap much benefit by repotting now; the better plan would be to loosen and remove a portion of the surface soil and apply a top-dressing of rich compost. Prune the plants during this month and the next, tie the points of the shoots downwards, and allow them to break very steadily and without any assistance from fire heat. They may possibly break back from the old wood. As they advance in growth a slight sprinkling of chemical manure over the surface of the soil will strengthen them, using a solution of cow manure and soot as the flower buds advance.

**Raising Seedling and Cutting Briars (*Notts Amateur*).**—The hedges should remain on the bushes till they assume a dark almost black colour, as then the seeds may be expected to be ripe. A brisk frost does them no harm. If there are only a few they may be placed in a flower pot and buried in the ground. If in large bulk they may be mixed with damp sand and buried in a pit. Take them out in March or as soon as the ground is in good working condition, separating the seeds from the husks, and sow them in drills 2 inches deep and a foot asunder, covering them with free loamy soil. They will not all germinate at once, and some may be long before producing plants. If sown late or until the soil gets dry and a hot summer follows they may remain dormant all the season, therefore sow as soon as the soil is in suitable condition; and if dry hot weather occurs before the seedlings appear shade the ground with brushwood or whatever will lay lightly on it and prevent evaporation. When large enough for transplanting take them up in the autumn, sort them, separating the large from the small, and transplant 6 inches apart in rows thrice that distance asunder; then when the stems are large enough for the reception of buds, also full of sap, so that the bark rises freely, insert the buds in them as low down as possible, and below any incipient buds on the stems. The stocks are not cut down before the buds are inserted, nor till the spring following, when starting into growth, they remaining dormant in the winter. Some growers consider stocks raised from Briar cuttings equal to seedlings. The cuttings are made from firm young wood produced in the summer, cut into foot lengths, all the buds being carefully removed except two or three at the top, and the cuttings inserted thickly and firmly up to those buds. Some die, but many grow, and are transplanted in the autumn for budding. The sooner they are put in after the present time the better, failure often resulting when the work is deferred till spring.

**Pansies and their Culture (*C. S.*).**—Several articles have appeared from time to time on the cultivation of Pansies. You do not state your object in growing them, but the following remarks on their characteristics and culture may be useful:—Many have written upon the characteristics which belong to it when really a superior flower, and their opinions are combined in the following:—1, Each bloom should be nearly perfectly circular, flat, and very smooth at the edge; every notch, or unevenness, being a blemish. 2, The petals should be thick, and of a rich velvety texture. 3, Whatever may be the colour, the principal, or ground colour of the three lower petals, should be alike; whether it be white, yellow, straw colour, plain, fringed, or blotched, there should not in these three petals be a shade difference in the principal colour; and the white, yellow, or straw colour should be pure. 4, Whatever may be the character of the marks or darker pencillings on the ground colour, they should be bright, dense, distinct, and retain their character, without running or flushing—that is, mixing with the ground colour. 5, The two upper petals should be perfectly uniform, whether dark or light, or fringed or blotched. The two petals immediately under them should be alike; and the lower petal, as before observed, must have the same ground colour and character as the two above it; and the pencilling or marking of the eye in the three lower petals must not break through to the edges. 6, If flowers are equal in other respects, the larger, if not the coarser is the better; but no flower should be shown that is under 1½ inch across. 7, Ragged or notched edges, crumpled petals, indentures on the petal, indistinct markings or pencillings, and flushed or run colours, are great blemishes; but if a bloom has one ground colour to the lower petal and another colour to the side ones, or if it has two shades of ground colour at all, it is not a show flower. The yellow within the eye is not considered ground colour. A suitable situation is the chief point in the cultivation of the Pansy; this should be one sheltered from all cutting winds, as these often kill the plants by twisting them about. The situation should be open to the free circulation of the air, and exposed to the influence of the morning sun, but protected from the midday sun; cool and moist, but thoroughly drained, for although the Pansy requires considerable moisture during the blooming season, and through the summer months, yet it is very impatient of superabundant moisture. The soil should be rich and tolerably light. Decayed Cucumber-bed dung is good, as also is decayed cow manure, and the soil which suits best is a light hazel loam, thoroughly mixed with a good portion of decayed turf from pasture land, by frequently stirring and digging, and to three barrowloads of this soil add one of the Cucumber-bed manure two years old. Manure water, particularly guano water, applied during the blooming season, is very beneficial. Those who intend to grow the Pansy for exhibition should select young plants well established from cuttings for the purpose. For the spring exhibitions in May and June, select plants struck the previous autumn, in August and September; and for the autumn exhibitions in September, select plants struck early in the spring, and after these have produced their blooms, save them for store plants, to produce cuttings, always having a constant succession of young plants for the purpose of blooming. The propagation of the Pansy is very easy. The young side shoots are to be most preferred for cuttings, as the old hollow stems seldom strike freely, and do not grow so strong. For spring blooming, take off a sufficient quantity of these side shoots in August or the beginning

of September, and for autumn blooming in April and May; these insert either under handglasses or in pots placed in a cool frame in some good light compost, mixed with a good quantity of silver sand, taking care to keep them moderately moist, and shading them from hot suns.

**Names of Fruits.**—The names and addresses of senders of fruit to be named must in all cases be enclosed with the specimens, whether letters referring to the fruit are sent by post or not. The names are not necessarily required for publication, initials sufficing for that. Only six specimens can be named at once, and beyond that number cannot be preserved. (*J. Mooreby*).—1, Duck's Bill; 2, Striped Holland Pippin; 3, Not known; 4, Bedfordshire Foundling; 5, Gloria Mundi; 6, Formosa Pippin, Flower of Kent and Beauty of Kent are not synonymous. (*James Wood*).—1, Margil; 2, Nanny; 3, Josephine de Malines. (*J. P.*).—1, Bellissime d'Hiver; 2, Doyenné du Comice; 3, Not known; 4, Cox's Orange Pippin. (*F. Jellico*).—1, Cellini; 2, Fearn's Pippin; 3, Ross Nonpareil; 4, Beurré Diel; 5, Not known; 6, Bezi de la Motte. (*W. M.*).—1, Blenheim Pippin; 3, Cellini; 4, Reinette Van Mons; 5, La Fameuse. (*H. W.*).—1, Duchesse d'Angoulême; 2, Verulam; 3, Pigeonnet; 4, Clayzate Pearmain. (*G. P.*).—1, Belle de Septembre; 2, Jefferson inferior; 3, Yellow Gage inferior; 4, Doyenné du Comice; 5, Cox's Pomona; 6, Bramley's Seedling; (*J. E.*).—1, Rhode Island Greening; 2, Blenheim Pippin. (*J. C.*).—1, Lamb Abbey Pearmain; 2, Kerry Pippin; 3, Aromatic Russet. (*F. W. S.*).—1, Wormsley Pippin; 5, Pearson's Plate; 11, Margil; 12, Lord Burghley. (*J. E. F.*).—1, Emperor Alexander; 2, Hawthornden; 3, Resembles New Northern Greening; 4, Napoleon; 5, Louise Bonne of Jersey; 6, Gansel's Bergamot. (*W. C. L.*).—1, Beurré Capiaumont; 3, Doyenné Boussoch; 4, Bellissime d'Hiver; 5, Louise Bonne of Jersey; 6, Glon Morceau. (*Saul Taylor*).—1, Cox's Pomona; unnumbered, Hollandbury; 2, Emperor Alexander; Pears, 1, Maréchal de Cour; 2, Not known, worthless; 3, Beurré d'Amanlis. (*F. A. L.*).—1, Easter Beurré; 2, Souvenir du Congrès; 3 and 4, Beurré Superfin; 5, Beurré d'Anjou; 6, Duchesse d'Angoulême. N.B.—In consequence of Dr. Hogg's absence from London, fruit cannot be named by him till after the middle of November.

**Names of Plants.**—We only undertake to name species of plants, not varieties that have originated from seed and termed florists' flowers. Flowering specimens are necessary of flowering plants, and Fern fronds should bear spores. Specimens should arrive in a fresh state in firm boxes. Slightly damp moss or soft green leaves form the best packing, dry cotton wool the worst. Not more than six specimens can be named at once. (*W. L. B.*).—*Taxus baccata*. (*W. R. S.*).—1, Davallia Mooreana. 2, Nephrolepis Duffii. 3, Adiantum excisum.

COVENT GARDEN MARKET.—OCTOBER 19TH.

BUSINESS quiet, with supplies quite equal to the demand.

PLANTS IN POTS.

	s. d.	s. d.		s. d.	s. d.
Aralia Sieboldi, dozen ..	6	5 to 12	Fuchsia, dozen ..	3	0 to 9
Arbor vitæ (golden), dozen	8	0	Geranium (Ivy), dozen ..	0	0
" (common), dozen ..	0	0	" Tricolor, dozen ..	0	0
Asters, dozen pots ..	3	0	Glaucolins ..	0	0
Azalea, dozen ..	0	0	Hydrangea, dozen ..	9	0
Begonias, dozen ..	4	0	Lilies Valley, dozen ..	0	0
Capsicums, dozen ..	6	0	Lilium lancifolium, doz.	12	0
Chrysanthemums, dozen	4	0	" longiflorum, doz.	0	0
Cineraria, dozen ..	0	0	Lobelia, dozen ..	0	0
Dracæna terminalis, doz.	30	0	Marguerite Daisy, dozen	6	0
" vtridia, dozen ..	12	0	Mignonette, dozen ..	3	0
Erica; various, dozen ..	9	0	Musk, dozen ..	0	0
Euonymus, in var., dozen	6	0	Myrtles, dozen ..	6	0
Evergreens, in var., dozen	6	0	Palms, in var., each ..	2	6
Ferns, in variety, dozen	4	0	Pelargoniums, dozen ..	0	0
Ficus elastica, each ..	1	6	" scarlet, doz.	3	0
Foliage Plants, var., each	2	0	Spiræa, dozen ..	0	0

CUT FLOWERS.

	s. d.	s. d.		s. d.	s. d.
Abutilons, 12 bunches ..	2	0 to 4	Lilies, White, 12 bunches	0	0 to 0
Anemones, 12 bunches ..	0	0	" Orange, 12 bunches	0	0
Arum Lilies, 12 blooms ..	3	0	Marguerites, 12 bunches	2	0
Asters, 12 bunches ..	2	0	Mignonette, 12 bunches	1	0
" French, bunch ..	1	6	Myosotis, 12 bunches ..	1	6
Bouvardias, bunch ..	0	6	Narciss, 12 bunches ..	0	0
Camellias, blooms ..	3	0	" White, English, bch.	0	0
Carnations, 12 blooms ..	1	0	Pansies, 12 bunches ..	0	0
" 12 bunches ..	4	0	Peas, Sweet, 12 bunches ..	1	6
Chrysanthemums, 12 bchs.	2	0	Pelargoniums, 12 trusses	0	9
" 12 blooms ..	1	0	" scarlet, 12 trusses	0	3
Cornflower, 12 bunches ..	1	6	Poinsettia, 12 blooms ..	0	0
Dahlia, 12 bunches ..	2	0	Primula (single), bunch ..	0	0
Daisies, 12 bunches ..	2	0	" (double), bunch ..	0	9
Encharis, dozen ..	3	0	Polyanthus, 12 bunches ..	0	0
Gardenias, 12 blooms ..	2	0	Ranunculus, 12 bunches	0	0
Gladiolus, 12 sprays ..	1	0	Roses, 12 bunches ..	4	0
Hyacinths, Roman, 12			" (indoor), dozen ..	0	9
sprays ..	0	0	" Tea, dozen ..	1	6
Iris, 12 bunches ..	0	0	" red, dozen ..	0	0
Lapageria, white, 12			" de Moiss, 12 bunches	0	0
blooms ..	1	6	Stephanotis, 12 sprays ..	4	0
Lapageria, coloured, 12			Tropeolum, 12 bunches	0	0
blooms ..	1	0	Tuberose, 12 blooms ..	0	6
Lilium longiflorum, 12			Tulips, dozen blooms ..	0	0
blooms ..	4	0	Violets, 12 bunches ..	1	0
Lilium lancifolium, 12			" (French), bunch	1	0
blooms ..	1	6	" (Parme), bunch	3	0

FRUIT.

	s. d.	s. d.		s. d.	s. d.
Apples, 1/2 sieve ..	1	6 to 3	Oranges, per 100 ..	6	0 to 12
Nova Scotia and			Peaches, dozen ..	2	0
Canada barrel	0	0	Pears, dozen ..	1	0
Cherries, 1/2 sieve ..	0	0	Pine Apples, English,		
Cobs, 100 lbs. ..	45	0	per lb. ..	1	6
Figs, dozen ..	0	0	Plums, 1/2 sieve ..	1	6
Grapes, per lb. ..	0	6	St. Michael Pines, each	5	0
Lemons, case ..	10	0	Strawberries, per lb.	0	0
" n. each ..	0	6			

VEGETABLES.

	s. d.	s. d.		s. d.	s. d.
Artichokes, dozen ..	1	0 to 2	Lettuce, dozen ..	0	9 to 0
Asparagus, bundle ..	0	0	Mushrooms, punnet ..	0	6
Beans, Kidney, per lb. ..	0	3	Mustard and Cress, punt.	0	2
Beet, Red, dozen ..	1	0	Onions, bunch ..	0	3
Broccoli, bundle ..	0	0	Parsley, dozen bunches	2	0
Brussels Sprouts, 1/2 sieve	2	6	Parsnips, dozen ..	1	0
Cabbage, dozen ..	1	6	Potatoes, per cwt. ..	4	0
Capsicums, per 100 ..	1	6	" Kidney, per cwt.	4	0
Carrots, bunch ..	0	4	Rhubarb, bundle ..	0	2
Canliflowers, dozen ..	3	0	Salsafy, bundle ..	1	0
Celery, bundle ..	1	6	Scorzoneria, bundle ..	1	6
Coleworts, doz. bunches	2	0	Seakale, basket ..	0	0
Cucumbers, each ..	0	4	Shallots, per lb. ..	0	3
Endive, dozen ..	1	0	Spinach, bushel ..	1	6
Herbs, bunch ..	0	2	Tomatoes, per lb. ..	0	4
Leeks, bunch ..	0	3	Turnips, bunch ..	0	4



MICHAELMAS.

FAILURES among Mangolds, Swedes and White Turnips are so general that many a farmer has sold his flock this Michaelmas at a serious sacrifice. Others cling to the sheep, and they do well if only they have food enough to support them either till spring or till they are fattened. Late lambs appear to be very unprofitable, and we were not surprised to hear one of our tenants say a few days ago that he really did not know what to do with his lambs, for he had given them oilecake ever since they could eat it, and now he had winter before him without any roots, and lambs were so cheap that to sell was to encounter a serious loss. This seemed to us one more instance of the evil of purposeless effort—of the want of an end and aim in one's work from the outset. It does not answer to breed either late or inferior lambs, and for ordinary or general purposes there is nothing equal to a good crossbred animal. We have more than once explained our preference for lambs from Hampshire Down tups and half-bred Suffolk. This cross gives us hardy vigorous lambs, which at sixteen or seventeen weeks of age realise some 30s. apiece if sold at the cattle mart in open competition with other lambs. We submit that such results are satisfactory in any season, but especially so this year when both pasture and root crops suffered so severely from drought. Not only have we found it answer best to have early lambs, but also either to sell early in June or to keep them till they can be sold advantageously as fat hoggets.

We have again heard complaints of the low price of lambs sold in July, yet we believe it will be found that cheap lambs in July were not by any means fine animals, for we have repeatedly seen lambs in July at South Down fair in Sussex as forward in size and condition as hoggets are often seen in the following February. Unquestionably it does answer to feed lambs well from the first, if only we take care to breed them well so as to insure early development. It is all very well for a man to boast of the number of his lambs, but if they are small weakly animals we certainly do not think he can render them profitable. The importance of caution in the use of Turnips for feeding pregnant ewes has often been mentioned, and the exercise of such caution was much called for when pasture became covered with snow a month or two before the last lambing season, for then the temptation to use roots freely induced some shepherds to be

imprudent, and an excessive use of Swedes led to losses both of lambs and ewes to a serious extent in several flocks. Such losses were all the more vexatious because they might have been avoided. Pea or Oat straw in racks, Oats and chaffed straw and hay in troughs, with a few roots daily, is a safe and nourishing dietary for ewes in December, and if some Cabbages or Thousand-headed Kale can be added there is nothing left to wish for. The chief thing is to give plenty of sound dry wholesome food, with just enough fresh succulent food added to promote health; beyond this we would not go till after lambing, when roots of all kinds may be used without risk and with decided advantage. We ought perhaps to qualify this statement with a word of caution, about the risk of scour in lambs from eating rotten Turnips which have been frozen, and though apparently sound are rotten inside. Scour also proceeds from a greedy consumption of Rye, but is easily checked by withdrawing the flock occasionally or frequently from such soft green food as is found necessary. These are trifling matters of detail, but they require prompt attention in order that harm to the lambs may be avoided.

We lost some ewes in the lambing season from debility. We had been careful to withdraw all over-aged or delicate ewes from the flock after the weaning, and we had to purchase a certain number to replace them. This cannot be done without some risk of buying a certain percentage of faulty animals, and it proved so in our case, careful selection notwithstanding. We have purchased no ewes this autumn from a resolution to curtail rather than add to our flocks with a short crop of roots and bare pastures till the end of August. Well is it to keep always within the scope of our means, and to have a moderate surplus of food rather than a want of it next March. A late spring and its attendant difficulties in food supply for the animals of the farm ought always to be taken into account in autumn, upon the principle that prevention is better than cure.

#### WORK ON THE HOME FARM.

The continuance of fine dry weather has enabled us to push on briskly with autumn work on the land. Corn sowing has been done quickly and well, a fine seed bed enabling us to cover the seed thoroughly and not leave any exposed upon the surface. A sharp outlook is notwithstanding being kept for rooks, as their depredations upon winter corn often does a serious amount of harm. Expediency has a certain amount of influence upon our corn sowing, as for example, at Little Rookwoods Farm, which came in hand this Michaelmas. The land has, under the lease of the outgoing tenant, been left under a four-course shift, and there is therefore some fifty acres of long fallow land which has been ploughed and harrowed so many times that it is quite free from weeds of any sort. We at once decided to sow this fallow with Wheat without manure now in order to get through with the sowing as quickly as possible, and in spring we shall give it a dressing of chemical manure. The result will be interesting. We hope too it will be profitable, as we have reason to suppose it must be, for results from the use of nitrogen and phosphorus upon Wheats this year have been most satisfactory. We had to take upwards of £100 worth of farmyard manure in the valuation of this farm, and shall use that manure for roots and spring corn. Why, indeed, should we not use manure as much for Barley and Oats as for Wheat? A fine bold sample of Barley always commands a good price, and it is still possible to obtain 40s. per quarter for Barley, but such a price for Wheat appears to be a vain dream now.

Farm covenants are curious—often vexatious when from some freak or other a clause or two has crept into the lease binding an incoming tenant to pay for straw by valuation or an excessive price per coomb for corn in order to keep the straw upon the farm. Local custom, too, binds one to make changes in valuations which press with undue severity upon the means of an incoming tenant, as for example, when a root crop has failed, and the full value of tillages and manure has to be paid.

#### AGRICULTURAL EDUCATION.

THE awakening which has recently taken place to the necessity of technical education, if we are to maintain our industrial supremacy amongst the nations, has naturally turned attention to the means of education in the most important industry of all, that of agriculture. We have persistently shut our eyes to the need of teaching our artisans the

science of their craft until our continental neighbours, who have been fully alive to the advantage of such teaching all along, are treading very closely on our heels by dint of it. If technical instruction is such a very practical benefit, why not apply its reviving influence to the industry that is languishing most with us, languishing, in fact, to the point of collapse? So we are hearing on all sides of the desirability of establishing more agricultural schools, and of doing something to promote the education of young farmers, that they may be able to checkmate foreign competition for all their genial climes and rentless acres by the mere exercise of superior intelligence. There is no harm in the movement. Our farmers, in common with the rest of us, will stand the infusion of a little more intelligence. But let us not lean upon a broken reed; let us not imagine that agricultural education can ever do for agriculture in this country what technical instruction has done for industrial art in Germany. We are authoritatively told, and the truth can be demonstrated by experiment, that no man, by taking thought, can add one cubit to his stature. Neither can the farmer, by exercising the most elaborately cultivated intelligence, make two blades to grow where one grew before. Nature obeys her laws. By manipulating her mechanical and physical laws we have succeeded in multiplying our productive power, in certain directions, a hundredfold. But our ability to manipulate stops at the laws of organic growth. We may foster growth, we may stimulate it, we may do much to insure the best result, but by no human process can we double or multiply the product fixed by Nature. Ingenuity backed by capital has worked miracles in the manufacturing world. To every man it has given a hundred hands. But what is its power upon the soil? Has the accumulated ingenuity of forty centuries improved very materially upon the agriculture of the Egyptians? They, at least, made agriculture pay; we do not.

My object in writing this letter is to point to the practical lesson in the fertility of agricultural education which we only need to look to the United States to learn. Farming is there an industry of greater importance, if that be possible, than it is in this country. Realising this, the American Congress, in the year 1861, provided for the establishment in each State of a College of Agriculture and Mechanic Arts. A substantial subsidy was granted, equivalent to some £2,000,000 sterling. Most of the institutions have now been in full swing for the best part of a quarter of a century. They are replete with every educational requirement, several of them having experimental farms attached, and all furnished with a staff of competent professors. They have been in existence long enough to secure the confidence of the public. Yet what do we find? We find that in the year 1885, at the Californian College, out of 246 students but 17 were taking the agricultural course; at the Illinois Institution, one of the most elaborately equipped agricultural schools in existence, of 356 students 21 were taking agriculture. It is the same throughout every State in the Union—buildings, experimental farms, large teaching staffs maintained to minister to about a score of youths per annum. In our own dominion of Canada we may read the same lesson. The Guelph Agricultural College is maintained by the Province of Ontario to teach its young men farming. The staff is most efficient; the fees are most nominal, yet the attendance is wretched, and would be worse were it not for the students who go over from England. There, in the United States and Canada, everything has been done for agricultural education that we could do—money spent lavishly, teaching talent brought from far and near. There, too, the agricultural population is relatively greater than with us, and the result has been failure. The farmers will not send their sons to be taught what they think they can teach better themselves. They dread the infusion of bookish tastes, since there is very little in common between studying the chemical composition of manures and applying them in all their odoriferous reality to the ground. Unless we want to waste the public money we would do well to take warning. To the limited extent that agricultural schools have been tried here they have given no promise of a success beyond the meagre measure they have had in the United States—if anything rather less, for surely the American, be he farmer or artisan, is a degree more go-ahead than we are.—J. A. WESTWOOD OLIVER (in *Glasgow Herald*).

#### METEOROLOGICAL OBSERVATIONS.

CAMDEN SQUARE, LONDON.

Lat. 51° 32' 40" N.; Long. 0° 8' 0" W.; Altitude, 111 feet.

DATE.	9 A.M.					IN THE DAY.				Rain.
	Baromet. ter at 32 and Sea Level.	Hygromet- er.		Direction of Wind.	Temp. of soil at 1 foot.	Shade Tem- perature.		Radiation Temperature		
		Dry.	Wet.			Max.	Min.	In sun.	On grass	
1887.										
October.										
Sunday .....	29.709	51.5	48.0	E.	53.6	53.9	47.4	57.8	46.2	0.041
Monday .....	29.412	46.2	45.9	S.W.	52.7	49.7	45.1	72.6	44.6	0.305
Tuesday .....	29.705	41.9	38.1	N.W.	51.1	48.9	32.6	91.4	29.9	0.025
Wednesday ..	29.638	35.6	34.1	N.	48.0	46.9	31.9	84.2	27.8	—
Thursday .....	29.788	35.0	34.0	N. E.	47.5	47.7	27.2	71.7	23.2	0.014
Friday .....	29.820	42.3	39.9	N. W.	46.6	49.6	35.0	68.4	31.8	0.035
Saturday .....	30.051	40.1	37.2	N.	45.8	50.1	34.2	93.7	29.4	0.380
	29.784	41.7	39.6		49.3	49.5	36.2	77.1	33.3	0.453

#### REMARKS.

- 9th.—Dull, foggy morning; damp and showery after.  
 10th.—Wet and dull in the morning; heavy showers and sunshine alternately in the afternoon.  
 11th.—White frost early; bright cool day.  
 12th.—Snow early; bright cool day; foggy evening.  
 13th.—Sharp frost early; damp, foggy morning; cloudy and showery afternoon.  
 14th.—Dull damp morning; storm of rain and hail at 1.30 P.M.; cleared in afternoon; bright night.  
 15th.—Fine and bright till 10.30 A.M., then showery.  
 A wet and very cold week, the temperature being 5° below the average, and more than 10° below that of the preceding week. The minimum temperature in shade on the 13th, 27.2° is the lowest recorded in October since 1881. The snow which fell on 12th remained visible on the ground for an hour or so, which is unusual in October.—G. J. SYMONS.





# COMING EVENTS

27	TH	
28	F	
29	S	
30	SUN	21st SUNDAY AFTER TRINITY.
31	M	
1	TU	Southampton Autumn Show.
2	W	

## AUTUMN WORK—OLD GARDENERS AND NEW.

**T**HE autumn may be said to be the beginning of the gardener's year, and if he falls behind with his work at this season, or if his preparations for the next are inadequate, his will not be a bed of Roses during the coming months. It is customary for proprietors of gardens to make changes in the autumn—not in respect to routine or improvement only, but of those whose duty it is to carry out what is required to be done. Gardeners, also, of their own account find the advantage of entering into fresh engagements in the autumn if they can enter on them soon enough. There is, perhaps, no period more favourable for changes of managers than the end of August or early September, as there is then time to make provision for a supply of early produce by autumn sowing, and propagating is also done by the person who is responsible for growing the plants and the general effect produced by them next year. When changes are made late in the year or in spring the character of the ensuing season's work is influenced by the action of the "last man," and the "new gardener" cannot be fairly estimated as to capacity till he has had a second summer in which to show the results of his own forethought and labour, for the work of autumn affects materially the results during the summer next succeeding.

As a rule, when a fresh gardener is placed in charge of an establishment, no matter whether it be large or small, a great change is expected in the way of improvement. No matter how able the old servant may have been, the new one is expected to excel him in every department, and in not a few instances more is expected than it is in the power of man to produce with the means at his disposal. These great expectations are thus not realised, and while those indulging in them may not feel exacting nor hard taskmasters they are yet disappointed, and through lack of knowledge, which they cannot be expected to possess, may form an erroneous view of the ability of the gardener who had been so highly recommended. The man is judged not by his own work alone, but by that which he inherited from his predecessor, and which might be different from his own if he had been there to lay the foundation of it.

Not long ago, in passing round a garden of no inconsiderable extent, the proprietor pointed disapprovingly to what he considered, and what unquestionably was, faulty in some if not most of the departments. "The place," he observed, "has been going steadily down for the past three years, and I have quite decided to have a fresh man. Look at those Vines," he continued, "the crop is worse than ever, and I must have something very different next year." His new gardener

was engaged to enter on his duties on November 1st, and it was clear from the tone of the remarks of the owner of the Vines that Grapes of exhibition quality were expected from them in 1888. In the interest of an unknown man it was thought advisable to point out that the Vines, which were a dense thicket of growths, and the small thin leaves "swarming" with insects to such an extent that they were curled as if seared, could not, under any possible treatment, be made to do what was expected from them so soon. By vigorous and well directed action in August in the way of cleansing and relieving the overcrowding, also by inciting fresh root-action in new soil given in September, some improvement in the next crop might have been effected; but even then a full crop of superior fruit could not have been produced. All competent gardeners know, and owners of gardens ought to be told, that it is the condition of the Vines this year that governs the crop of the next; and in the case in question, when the matter was explained, the real facts of the case were to some extent, and it is hoped to a large extent, appreciated.

The flower garden was also certainly not in the condition it ought to have been and might have been with the resources at disposal. It was expected to be fresh at least, if not gay, in the early part of the shooting season, or in September and the beginning of October, yet several of the beds had been bare for weeks through the wrong kinds of plants having been employed—dead hardy annuals and dying Stocks, yet not an Aster to be found. The whole of the beds were expected to be massed with Pelargoniums and plants of that nature next season, yet cuttings were not inserted nor provision made for filling one-fourth of them when an early frost had left its deadly impress on the leaves. As was pointed out, how was it possible for a coming man to do what was relied on, without purchasing at the least 10,000 plants to effect the purpose? Great virtue is attributed to the "master's eye," but it must be trained to be able to judge fairly and suggest effectively. The eye had not seen the lack of preparations this autumn, and the mind next summer might consequently be unable to comprehend the difficulties of the position that would be then experienced, or at the least to fully appreciate their true origin and real cause. In the kitchen garden also no satisfactory preparations had been made for the spring and early summer supply of vegetables; and though an able man can do much in raising early Cauliflowers and Lettuce under glass he cannot find substitutes for Cabbage, Spinach, and Lettuces that ought to have been raised outdoors in the autumn. This is in no sense a fancy picture, but the accurate record of existing facts.

It is not suggested that all new gardeners are better than the old. The very reverse may be the case, and instances must be familiar to most persons of experience, of owners of gardens acting contrary to their own interests in effecting changes without due consideration, or through misconception of the circumstances of the case; nor, on the other hand, can any assurance be felt that all gardeners when approaching the expiration of their term and nearing their departure make the same provision for the future that they would if they remained to incur the responsibility of their own work. Those who are lax in this respect err very grievously, for they do injustice to themselves, deprive their employer of his rights, jeopardise the position of a successor, and bring discredit on the craft to which they belong, and from which they

ought to be excluded. Every right-minded and prudent man who has some thought for his future exerts himself to his utmost during the closing period of his term to have the garden well furnished, and as far as in him lies to leave no just cause for complaint behind him. It is pleasant to feel there is no lack of such high-minded gardeners, and very few of them fail to have their services recognised sooner or later; but it is not pleasant to have a new gardener ever on the search for faults of the old for the purpose of exposing them, nor is it agreeable to find the gardener who has left a charge taking advantage of opportunities for disparaging the man in possession, and the sooner such paltry jealousies are obsolete the better for all, and especially for those who are afflicted by them.

Change, for the mere sake of change, seldom proves of advantage to any, and the fickle-minded and fanciful who are always looking for and often making room for the supposed perfect man are not very likely to find him; and masters who are fairly served, and men who are fairly comfortable, may easily err by too hasty action, as many have erred in past times, and regret they did not try to mend what they ended too abruptly.—EXPERIENTIA DOCET.

### FERNS—WINTER TREATMENT.

EVERYONE interested in the culture of plants of any kind is agreed that as the season advances the care which plants of all sorts require now is greater than at any other time of the year. It is well known and easily understood that when a plant, whatever may be its nature, is in full vegetation its health is not so easily affected by lack of constant attention as it is when in a dormant state. But, notwithstanding the truth of the above statement, it must always be borne in mind that in trying to avoid one evil it frequently happens that one falls into another, the results of which, if not so glaring, and consequently not so easily detected, are quite as bad and as detrimental to the health of the plant which is affected by it. Many plants during the winter require to have their roots kept comparatively dry, but though an excellent rule as applied to the generality of plants this, however, has some serious exceptions. One of the most prominent of these exceptions is in regard to Ferns, either cultivated in the stove or in the greenhouse, or grown in frames or even outside. The advice consisting in keeping Ferns dry at the roots during the winter, frequently tendered by people professing to be well acquainted with all the requirements of these plants, is a most injurious and perfectly erroneous notion, as is amply shown by the ways of Nature. If anyone will only take the trouble to observe the treatment to which most if not all Ferns are subjected in their natural stations, he cannot fail to be convinced that many cases of failure in the culture of these plants are traceable to dry winter treatment.

Taking as an example our own British Ferns, we notice that one and all of them receive a much greater amount of moisture during the winter, their resting season, than while under the influence of summer heat and drought when in full growth. It is not only those generally dwarf-growing kinds, such as the Scale Fern (*Ceterach officinarum*), *Asplenium trichomanes*, the Wall Rue (*Asplenium Ruta muraria*), or the Downy and Alpine Woodsias, all of which are found growing naturally on rocky and exposed places, or on walls, which, during the summer when their vegetation is active, receive a great deal less water at the roots than during the winter; but also all the stronger growing kinds which naturally thrive under the shadow of the hedges or under the shade of the trees. In such positions the Ferns during the summer are kept comparatively dry, for the simple reason that whatever rain comes down can hardly reach them on account of the protection of the foliage overhead. Ordinary showers only make the atmosphere surrounding them more humid, but do not penetrate through the foliage of the trees under which our Polypodies, some of our Spleenworts (*Aspleniums*), or the Bladder Ferns (*Cystopteris*), and others grow so luxuriantly, and the same may also be applied to the hedgerows by the side of which that which for some reason or other is erroneously called now the French Fern (*Asplenium Adiantum nigrum*) and the Hard Fern (*Blechnum spicant*) generally grow. These, no doubt, to a certain extent benefit by the general moisture of the atmosphere thus occasionally produced during the active period of their growth; but it will be perceived at a glance that such superficial humidity

produced at a time when through the action of the sun it soon vanishes is not to be compared with the thorough soakings which the same plants enjoy during their period of rest, when trees and shrubs alike are deprived of their foliage, and consequently offer no hindrance whatever to the autumn and winter rains, every drop of which actually finds its way to the Ferns growing under their friendly shelter. Now, if we add to this argument the fact that during the resting season of the Ferns rain is at least ten times more frequent than at any other time, we shall, I think, have clearly demonstrated that, far from having their roots kept dry while at rest, they are, on the contrary, kept particularly active by what we must consider a wise provision of Nature.

Then, again, what can be said in favour of a comparatively dry winter treatment in regard to those kinds which grow in quite the open meadows, such as the Lady Fern (*Athyrium Filix-fœmina*), the Male Fern (*Lastrea Filix-mas*), the soft and prickly Shield Ferns (*Polystichums angulare* and *aculeatum*), or of those which, like the Royal Fern (*Osmunda regalis*) are found on banks of streams, which places during the summer, and especially during such a summer as we have had to endure this year, being in most cases exposed to the full effects of the sun are partially dried up. Why, we are bound to conclude that their freshness, which they retain the whole summer through, in spite of the heat and drought to which they are subjected for weeks together, is only due to the extraordinary amount of moisture stored in the ground through the winter, during which time they are frequently thoroughly covered over with water for two or even three consecutive months. Yet in that position the Male Fern, Lady Fern, *Osmunda*, and *Polystichums* not only grow but luxuriate. We know from experience that during comparatively dry winters such plants as the Oak and Beech Ferns, for instance, have their slender underground rhizomes shrivelled to such an extent that when spring comes they only make a very poor start.

But if such is the case with Ferns in their natural state and growing in the open where there are no impediments to their roots, which have the full benefit of every drop of moisture contained in the ground, plants in pots must surely be more severely affected, for in their case the terminal sucker of nearly each root is brought in contact with the pot and dries up much more rapidly than in the open ground. There is evidently no reason to think that the treatment which our own Ferns receive in their natural state is not identical with that which is dispensed to exotic kinds. During its resting time the *Adiantum pedatum*, for instance, a Fern of particularly great beauty, which in North America is found growing very extensively in exposed places, remains when at rest, during the winter, covered for two or three months with a coating of snow, the thickness of which varies from 2 feet to 3 feet and occasionally more. Now, this quantity of snow has for immediate effect to prevent anything like a dry winter treatment at the roots, and also to supply the dormant plants beneath with a quantity of moisture far greater than anything to which they are exposed during the summer. It is therefore not surprising to find that under cultivation that lovely Fern has the most undeserved reputation of being a bad grower, and that frequently after four or five months of dry treatment its crowns have vanished. It is the same with most of the deciduous Ferns, which class of plants amateurs in general are more and more inclined to eliminate from their collections under the pretence that they are usually lost during the winter. If they are so lost, it is evidently from the want of moisture at the roots during their resting time, and if the effects of such a pernicious yet general treatment are so disastrous to plants devoid of foliage, it certainly follows that Ferns of an evergreen nature must by the same treatment be punished to a greater degree still. From what precedes we must not conclude that the present treatment only needs reversal, making the summer treatment a dry one, superseding that which is now in favour during the winter, for when Ferns are in full growth their requirements, so far as liquid at the roots is concerned, are a serious consideration; but at the same time these waterings must neither, as is frequently the case, cease altogether for the deciduous kinds, nor become for the evergreen ones so very remote as to be of almost practically no value for keeping the roots of the plants in a perfectly constant state of moisture, which Nature teaches us is the state in which Ferns should be kept during their resting time.—THEO.

### COARSE VEGETABLES.

WHEN Mr. Iggulden penned his little note on page 335, I hope he did not think I was dead and thus not able to reply to it. I assure him I am in the land of the living, and there hope to remain for some time, but, as I am advancing in years, try to spend as quiet a life as circumstances permit. He, however, disturbs my rest, and I shall have no difficulty in showing how erroneous is his statement concerning me, but as to putting him right, that is another matter, and I imagine not a very easy task to accomplish.

It is not necessary for me to say that Mr. Iggulden is a hard hitter in a controversy, and like some others seems hurt if he gets a sharp return. He must not expect glory without scars, which, well won, are honourable, and if he fear them he will do well to be careful in his attacks. Your correspondent is apparently getting entangled in his own misconceptions. I feel confident that if he searches through every page in the Journal he will be unable to place his finger on one sentence over the signature of "A Northern Gardener" that attributes to him the "exploiting" of anything good, bad, or indifferent. If he had, stated I had detailed my experience of growing certain crops he would have perhaps exercised better taste; but he makes a definite assertion in these words—"It was 'A Northern Gardener' who detailed his 'exploits' in the way of growing Beet for the pigs," and other vegetables that were condemned for their coarseness.

I have in reply to tell your correspondent that it is not in his power, nor in the power of any man, to authenticate that charge. So far from growing unwieldy Beet, wasteful Celery, and gigantic Onions, I grew just the opposite when I was writing on the subject, and it was because I did so systematically, and because the produce met with approval, that I advocated high quality against mere size, and denounced the waste that I found attendant on attempts to produce examples of vegetables of unwieldy proportions.

So far from detailing my "exploits" in blundering in the way suggested, the Beet grown was so much admired for its small size and sweetness that I had to send packets of seed to guests of the family, and I have distributed in that way hundreds of ounces; but though the selected variety was no doubt good, the roots would not have been so small and juicy if the sowing of the seed had not been deferred till the end of May or early in June, and in very deep and fertile soil, enriched the previous year for Celery, and the growth of the crop stimulated with nitrate of soda. Sowing in March or early in April is the way to get Beet too large for table, and growing it in poor shallow soil is the way to have it dry and earthy in taste.

As regards wasteful Celery, my practice at the same time was to grow for the main crop the most compact variety I could find, and this was a choice selection of Turner's Incomparable, subsequently known as the Sandringham. The seed was sown thinly early in April in a layer of rich soil on a bed of leaves that heated mildly. The bed had the protection of mats when needed, and the dwarf sturdy plants were transferred direct to the trenches after the early Cauliflowers and Cabbages were cleared off in June or early July. The Celery was grown about 10 inches apart, five rows in each trench, 3 feet ridges between. Mr. Iggulden will perceive that close cropping prevailed, and as a practical man will know that plants so raised and grown could not be made large and coarse by any possible means. They were wanted small, with the least waste in trimming, and were small, yet large enough, and the hearts white, crisp, and solid. If he can state how more heads can be grown on a given space with less waste of time in "pricking out," and of material in the form of luxuriant leafage, he will, I respectfully submit, be better engaged than in formulating a charge against me of being humiliated by having my produce turned out of the garden as unfit for human beings to eat.

When ground is limited and demands great it is necessary to grow the greatest amount of produce that will actually be used, and under these circumstances huge Onions are huge mistakes, therefore my practice was to sow thinly in drills, and leave the plants to grow and the bulbs to find room for themselves. They were nothing to be proud of as regards shape and size, but there was always plenty when wanted, and in sizes to suit various culinary purposes. When Onions were grown of sensational size in the same garden the waste was so great in the scullery that purchasing had to be resorted to long before the season was over, but I never had to spend a penny for extra supplies. So much for my "exploit" in growing big Onions, and so I might go on in respect to other crops, but it is not necessary.

If Mr. Iggulden ever has to provide vegetables and small fruit for twenty persons daily, and often more, from an acre of land, and does supply them with produce in season for seven years without a blank to cause an inquiry, he will find he has no room for growing crops to be wasted. He will also find out something else—namely, that he would fail completely by a system of wide planting in soil dug a spit deep and a hard sole a foot below the surface. He would have to resort to closer cropping than he has yet described, and to deeper and better land working. It is close and constant cropping that proves the value of a deep and good rooting medium. Where there is such a wide expanse of surface that a slipshod method suffices, the capacity of the ground is seldom developed, because the spur of necessity is not applied; and if Mr. Iggulden considers that vegetables must of necessity be coarse and inferior when grown in soil that is both rich and deep, my experience, not exploits, justifies me in expressing my belief that he is labouring under a very great delusion. Such a dictum, by whomsoever advanced, I am convinced is unsound and indefensible.

Mr. Iggulden may say that the views which he has advanced condemnatory of trenching land in gardens have been exaggerated or not understood; that his qualifications have not been appreciated, nor his modifications sufficiently taken into account. This may be so, and I am one of those who suspect he is not such an extremist as many suppose him to be; but it is not what a person intends to convey, but the effect of his utterances that make or mar his reputation, and I am constrained to say that our mentor has not done justice to himself in treating a subject that has given rise to so much controversy, because of the impression created that his teaching had a retrograde tendency.

His intentions have no doubt been of the best. In his desire to avoid what he considered a wasteful expenditure of labour in trenching when trenching was not needed, and in doing the work recklessly and wrongly when it was undertaken, he in a moment of earnestness overshoot the mark and he was understood, rightly or wrongly, to assail a system that as such is practically unsailable. I have planted many crops without even digging the ground for them, because the firmness of that particular soil was advantageous, and because I knew it had been deeply worked previously and that its fertility was ample for those crops; but so far from this being evidence against deep culture it is the strongest possible testimony in its favour as judged by the value of the two or more crops obtained after one working of the land.

Although Mr. Iggulden has allowed himself to be tempted to make an allegation that cannot be substantiated I do not seriously dissent, because it was founded on a mistake and will do me no harm. The mistake was this. I described with exactitude the practice of a hard-working man who persisted in growing vegetables of a substantial size against the desire and often expressed wishes of his employer, who conveyed a stern rebuke in having a lot of coarse Beet and other things cleared away. I was not very likely to indicate the perpetrator of the error or it would have prejudiced him in obtaining a situation where gigantic vegetables were not disapproved, and I am glad to know that such a position was found for him. I recorded the facts of the case as a lesson and a warning that might possibly deter others from pursuing a similarly mistaken course of pleasing themselves instead of complying with the wishes of those whom they might be engaged to serve. Those are the facts, and so far from my having incurred displeasure by my methods of procedure I was presented with what I never expected, and did not know I had deserved, every member of a family joining in a tribute that would not have been accorded for growing coarse vegetables.—A NORTHERN GARDENER.



#### ORCHIDS AT ARNOT HILL, ARNOLD.

A FEW miles from Nottingham is the residence of C. G. Hill, Esq., and although gardening is cherished there in all its branches, one can soon see that Orchids are a specialty. The varieties have been very carefully selected, and the healthy condition of the whole collection testifies to the care and attention bestowed by Mr. Albert Philp, who has charge of them.

The first houses are large and span-roofed, connected by a corridor on the north. This is in three divisions, the first being filled with *Odontoglossum vexillarium*, all clean healthy pieces. The useful autumn-blooming variety *rubellum* is well represented by fine plants in flower. The second part contains most of the *Masdevallias*, and in bloom are *M. Harryana*, *M. macrura*, *M. Wallisi*, *M. trochilus*, *M. Veitchiana*, and *M. bella*, which continues to bloom all the year round, while the third is used for the cooler *Odontoglossums*. At the time of my visit on September 24th there were forty spikes of blooms, chiefly *O. Alexandræ* and *O. Pescatorei*. Of the former there were large healthy plants with twenty growths each and branching spikes. Most of the flowers were of the large type, and some heavily blotched. A fine form of *O. Pescatorei* having broad petals and sepals well marked is a near approach to the famous *O. P. Veitchi*. Another large branching spike had about three dozen blooms on it. Others doing well in this house were *O. Halli*, *Oncidium macranthum*, *Mesospinidium vulcanicum* in bloom, *Epidendrum erubescens*, and *Odontoglossum coronarium*. On the roof are suspended many *Sophronis grandiflora* in pans, with good flowering growths. *Cœlogyne cristata* is noticeable in the first large house, being over 3 feet through, also large pots of *Pleiones*, the old *Cypripedium insigne* 4 feet across and equally good, *C. Boxalli* and *C. villosum*, and the sweet-scented *Oncidium ornithorhynchum* with its graceful spikes of bloom. *Dendrobium Hilli*, named in honour of the possessor, is represented by a large specimen with many growths. Other members of this genus have completed growth and are at rest on the cool side of the same house, *Dendrobium Wardianum* being well ripened and promising well for a good display of bloom. The *Lycastes* and *Maxillarias* are accommodated here, also large pieces of *Cymbidium giganteum* and *Sobralia macrantha*.

The *Cattleya* house contains some rare treasures. Nearly all the varieties of *Lælia anceps* are grown with the white forms, *Sanderiana* and *Stella*. Among others flowering *L. a. Hilli* is very distinct, being lighter in colour than the variety named *Percivaliana*. *Cattleya gigas* has made a grand show, but these were past at the time of my visit. Of *C. aurea* I saw a fine plant with a bloom having



a large lip and broad sepals and petals. *C. Trianae* alba is furnished with several sheaths. All the *C. Trianae*, *C. Mossiae*, *C. maxima*, and *C. Gaskelliana*, with the white variety, have done remarkably well.

Large plants of *Cymbidium eburneum* and *C. Lowi* are in splendid condition. *Calanthe masuca* had a strong spike and many blooms. *Vanda coerulea* was conspicuous in the next compartment, with fine heads of bloom, the finest form having thirteen flowers on a spike. *Cypripedium Spicerianum*, another valuable plant so useful for autumn and early winter bloom, is grown here in quantity; *C. Domini*, *C. longifolium*, *C. Roezli*, and *C. Sedeni*, giving a succession of bloom, remain in beauty for months; *C. Harrisianum*, *C. Stoneanum*, *C. vexillarium*, and many others are in robust health. There is also a quantity of *Cypripedium* seedlings, no doubt interesting hybrids, which will be heard of again on some future occasion. *Ceologyne Massangeana*, immense plants, have been yielding many spikes for a long time. Other occupants are *Angraecums*, *A. eburneum*, and *A. Ellisi* being extra good, also *Aerides Larpentae*, *Vanda insignis*, true, and various *Miltonias*. Only a few *Phalaenopses* are grown, but these are very good.

In another house are good specimens of *Oncidium ampliatum majus*, *Laelia crispa*, *L. elegans alba*, *L. harpophylla*, *L. Perrini*, *L. cinnabarina*, the true autumn-flowering *Cattleya labiata*, *C. Reineckiana*, and *C. Wagneri*, with many others equally valuable.

After passing some useful plant houses, vineries, &c., we arrive at a long lean-to facing the north in three divisions. *Odontoglossum tripudians*, of which there are many, is blooming in the first part; *O. Rossi majus* and *O. Edwardi* are numerous. The second contains hundreds of *Odontoglossum Pescatorei* and some of the *O. grande* section, and the last is full of *Odontoglossum Alexandrae*. All the stages are covered either with Derbyshire spar or coal siftings, and a good supply of rain water is provided in large tanks underneath.

It is interesting to note how healthy all the plants are, considering an accident which happened nearly three years ago, when a boiler gave way in frosty weather. Many of them were frozen, but fortunately only a few were killed.—G. W. CUMMINS.

### NATIONAL AURICULA AND PRIMULA SOCIETY.

As the time is now arriving when the rules for next spring's show will be in course of settlement, I have the following suggestions of amendment in those rules to make, as the result of my recollections of the past year's show. Mr. Douglas, I believe, generally approves these suggestions, or most of them, but thinks it well that they should be ventilated in your columns, and agreeing with him on that point I venture to invite criticism and improvement from yourself or others. My suggestions are:—

1, That at least in all the Primrose classes exhibitors should be invited to show any quantity of each kind, and this not only in pots (which should be optional) but in baskets or boxes surfaced with moss, or otherwise naturally "set," for instance, in herbage. The effect would be incomparably better; but, as the rules at present stand, exhibitors would not feel free thus to exhibit. Similar advantage might accrue from a like invitation in the species of *Primula* classes.

2, That to avoid all doubt and ambiguity, and to disqualify from the class for double Primroses any of the "duplex" (hose-in-hose) varieties, the words "flore pleno" should be inscribed in brackets, as descriptive of the double flowers intended. It is difficult to deny that a "duplex" is a double, for it is the literal translation of the word. As obviously ought the two varieties to be kept quite distinct, as they always, in fact, have been.

3, The difference between a Primrose and a Polyanthus requires definition (which it at present lacks) and that very carefully. For there is scarcely a Primrose which does not occasionally, even frequently, produce "bunched" blooms (and thus become a Polyanthus). I am mistaken if Polyanthuses were not shown as Primroses this year in quantity. Certainly they are popularly thus confused. The whole of Mr. John Waterer's exhibit of "Primroses" were, in fact, "Polyanthus." I apprehend that the difference is that the Primrose, however it may at times yield bunch blooms, normally produces single blossoms only, or at least produces some such blossoms. Either there should be a condition that from plants shown in Primrose classes any "bunch" blooms should be removed, or alternately (without exacting this) some such definition as above of the true Primrose should be laid down, or as a further alternative, if thought desirable, it should be laid down that, for purposes of the exhibition, every Polyanthus may be deemed a Primrose.

4, My last suggestion is perhaps rather for an enlargement of the scope of the Society and of the show than for an addition to the rules. It is that *Androsaces* and *Anemones* (at least species of

*Anemones*) should be hereafter included in both. If this extension were adopted, my above suggestion, No. 1, would be, in my view, additionally applicable.—H. SELFE LEONARD.

### GARDENERS' ORPHAN FUND—A SPECIAL APPEAL.

WITH your kind permission I would ask those whom I have not written to, as well as those I have sent to specially, to note that I shall be very pleased not only to receive their subscriptions, but to give any particulars that may be required, and also to forward rules, &c., of the above Fund. Having been for some time pushing the objects of this Fund, I am somewhat disappointed at the present results of my efforts. It is true that times are bad, wages low, and retrenchment the order of the day. Still, I think 5s. per year could be sent by most gardeners without much distress to themselves. I have to make my return in December, and hope to show a good book. Readers please note this, and while fresh in your mind send on to me at once. These remarks apply more particularly to the Norfolk brethren, though I am allowed to solicit and receive subscriptions from anyone out of the county.—STEPHEN CASTLE, *Local Secretary, West Lynn, Norfolk.*

### BALLAST BURNING.

THE approach of the calm wet months of early winter induces me to remind your readers that this is the best time of the year for burning clay, &c. Labourers will soon be unemployed, and small coal is cheap. Is it not, then, wisdom on the part of landowners to set to work and thoroughly drain their land by the ballast system? I would suggest to everyone who has a garden, the subsoil of which is clay, to try the experiment of digging trenches 3 feet deep and say 10 feet apart over the entire area, putting at the bottom of the trenches 2-inch drain pipes connected with the house drain, burning all the clay that is dug up, and turning the burnt clay back after passing it over a screen. The fine material that passes through the screen when dug into the surface soil will permanently lighten it, as well as supply a large quantity of soluble alkaline salts to the land. I am at present burning a hundred cubic yards of clay for this purpose, and, with your permission, will send particulars of the cost as soon as the work is completed. If any of your readers desire to see the operation in progress I shall be happy to show it to them. My address can be had from the Editor.

In close proximity to the limestone rocks of this country there is generally an abundance of clay land which requires draining, liming, and loosening in texture. Here ballast-burning would be invaluable, and where it is going on the lime problem is exceedingly simple. The cost of reducing a ton of limestone to quicklime on a ballast fire never exceeds 1s. I may state that any description of clay will burn provided it does not contain too much sand; in such a case what is wanted is, of course, the plough.

A year ago, in describing the method by which clay is burnt, I recommended the use of the fine material as a manure for Potatoes. This year I grew 600 feet run of Early Rose in a stiff yellow clay, with no other "manure" than fine ballast siftings. The yield has been 120 gallons from the entire crop. As to the flavour, flouriness, &c., of the tubers you will be able to judge from the specimens I send herewith. Might I respectfully suggest to farmers that there are thousands of people who would rather pay £20 a ton for Potatoes with a fine flavour than £2 a ton for organised insipidity?—W. M.

[Potatoes have assumed abnormal shapes this year in many places in consequence of heavy rains after a long period of drought; still, taking this into consideration, we think the tubers sent are of the Beauty of Hebron, this variety being often sold as Early Rose by London vendors who are not experienced gardeners, nurserymen, or seedsmen. The tubers sent were cooked, and we never tasted either of the varieties named of better quality. We shall be glad to have the particulars of the cost of burning clay soils obligingly promised.]

### FLOWER GARDENING.

MUCH discussion has taken place from time to time respecting the advisability of relying exclusively upon hardy plants for the adornment of the flower garden, thus saving the expense of annually propagating and wintering large numbers of tender plants. This, however, is not a gardener's question so far as a decision rests as to the changing so marked a feature as the flower garden is in the majority of estates. It lies within the province of a gardener to bring the merits of all plants that he thinks may be suitable to the wants of the garden under his charge before the notice of his employers. If they or any of them are wanted there is no fear but the gardener will get full permission and encouragement to grow them; and if not wanted there will be slight likelihood that he will be able to find a place for them longer than his master or mistress wishes. That has been my experience, and it is not by any means rare.

Coming to the practical question as to the present position of flower gardening, there does not appear to be a great falling off in the employment of bedding plants. So long as proprietors are able to keep a garden the culture of flowers does not fall off appreciably. In cases where the house is closed it is only natural

that all kinds of gardening not actually of a profitable nature should be allowed to lapse. But when the house is inhabited, especially in the summer and autumn months, bedding plants are, and long will be, much appreciated. The bedding-out system has been inadequately represented in many gardens, but worse than that, it has been caricatured by both employers and their gardeners through a very common lack of appreciation of the effects of colour and arrangements. I do not intend to say a word against bright colours. They are indispensable. The fault is in the use made of them. No colour is more often rendered unpleasant than yellow, and yet no colour when rightly employed is more effective or more pleasing, especially in autumn. It does not matter much whether the effect is produced by a mass of Calceolarias, single Dahlias, or *Précocité Chrysanthemums*, of single Marigolds, common Cornflowers, Violas, or Pansies, the effect is much the same in all, though I prefer variety of form when it can be had, so grow them all, and many more yellow flowers beside. It is only when trying to associate any of these with flowers of another hue—crimson Pelargoniums, scarlet Tritomas, blue Lobelias, or Violas, and these again with others—that so often the fatal mistake is made and condemnation follows. But putting that aside as a fault which is apparent in every branch of gardening where colour is a feature, it is perfectly certain that no plants have yet been found that are capable of superseding the ordinary bedding plants. True, we do not now require to confine the plants we grow to a few; such recent additions as Tuberosus Begonias and single Dahlias, and those of a later date, such as Violas and *Tropæolums*, are of themselves features which have done much to change the appearance of ordinary bedding. Still, the fact remains that some of the older sorts cannot be dispensed with. Calceolarias are still bright, Pelargoniums as represented by the newer varieties are much brighter than of old, Lobelias are better, so are *Ageratums*. Those who are fond of leaf effects have a very wide selection. Of hardy annuals themselves we have quite a good number; Phlox Drummondii is a host in itself, *Tropæolums* in beautiful variety, Snapdragons, Marigolds, and older kinds like Saponarias, the crimson Flax, &c., are useful.

What about hardy herbaceous plants? Is it necessary or desirable even to revert to the condition of gardens before the bedding-out system, with all that was bad about it, opened the eyes of the whole community to the beauty of flowers? Shall we not rather do as we are; and have been doing for years, change what is bad and repugnant to refined and educated taste in the bedding-out system, and at the same time add all we can of the beautiful, whether they be tender or hardy, to the number of our outdoor decorative plants? That is the system I am pursuing, and it is the system which must prevail in the future. We are a changeable people, but we are also utilitarians, and from among the crowd of new and old plants which have found their way into gardens during the past dozen years those which are best fitted to adorn our beds, borders, lawns, and desert places will alone remain, and the many which are of doubtful effect pass out of sight. If I may be permitted I would strongly advise gardeners to get out of all ruts, and to strike out for themselves decorative features suitable to their particular cases. The treatment of hardy plants from a decorative point of view is in very many cases quite as bad as ordinary bedding ever could be. Passing through gardens we hear the oft-repeated never-ending phrase about there being always something fresh "coming out" among herbaceous plants, and too often that is their only redeeming point. The overwhelming majority of garden possessors do not so much want "something interesting to look at" as bold effects and plenty of flowers, and whether these are tender, half-hardy, or hardy, softwooded, annual, or perennial will not trouble them. Nothing I am acquainted with can compete in richness of effect with Henry Jacoby Pelargonium, and no other flowers of the same colour last for so long a period. Yellow Calceolarias hold exactly the same position among yellow flowers, and we might note others; but although this is the case we find room for growing large quantities of Tritomas, of *Précocité Chrysanthemums*, of *Sedum spectabile*, of all sections of Dahlias, of Michaelmas Daisies, of Daffodils, Primroses, Polyanthus, Paris Daisies, Carnations, Pentstemons, Phloxes, Asters, Pansies, Lilies, of many annuals, &c.; and I am fully persuaded that the gardens and grounds would suffer were we to do away with any particular section of plants.—B.

#### GELASINE AZUREA.

A BULB GROWER desires some information respecting this little-known plant, which he will obtain from the following note:—*Gelasine azurea* was first introduced into this country in the living state in 1837, having been sent from Boston, U.S., to the collection of the Dean of Manchester at Spofforth, where it flowered and ripened its seed. It is a native of

the Banda Oriental, and the province of Rio Grande, where it occurs in stony places. It is sufficiently hardy to bear exposure in this climate especially if covered with a few dry fern leaves, and, like some of the Irises, retains a part of its foliage through the winter. It is readily raised from seed, and young plants will produce flowers the second season; so that it will, we hope, soon be classed amongst the commonest of our hardy bulbs. The seeds germinate most freely when sown as soon as ripe on a gentle heat, and the seedlings should be kept growing through the winter. The plant also produces offsets, by which it may be increased.

It grows from 18 inches to 2 feet high, the flower stalk being furnished with four bracts placed at regular distances, the upper one being leaf-like. The leaves are from 1 to 2 feet in length, and about 1 inch in breadth, pointed at their extremities, and plaited, as in the case of the Tiger-flower (*Tigridia pavonia*). The flowers are produced from a spathe, which is shorter than their footstalks. The funnel-shaped limb of the blossom is divided into six regular segments, alternately smaller, which are united at the base into a tube; each segment is marked with white at its base, on which are several black spots, the segments themselves being of a deep blue tint. The three filaments are united into a short

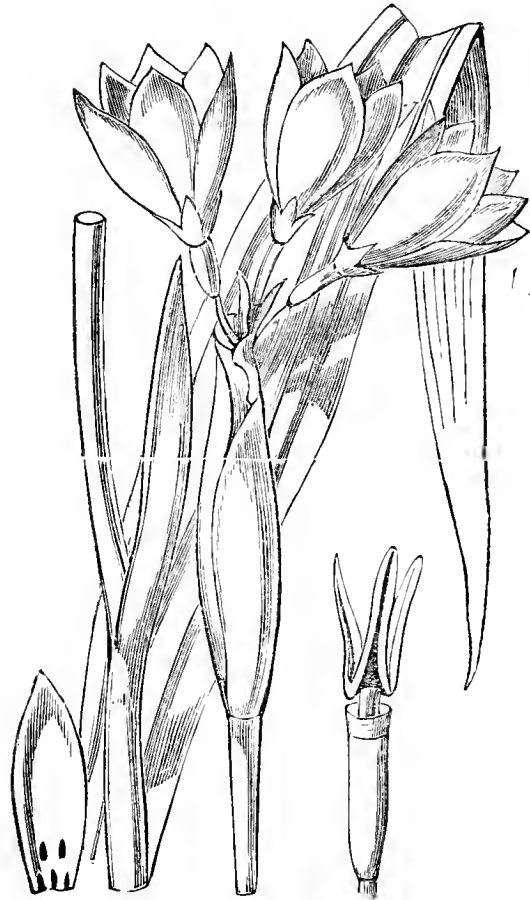

Fig. 46.—*Gelasine azurea*.

tube, in other words monadelphous, the anthers tapering upwards, and opening by their sides.

#### DRAYTON MANOR.

THE Staffordshire seat of Sir Robert Peel is one of the most beautiful in the county. The surrounding country is slightly undulating and well timbered, and evidently the trees were planted with due regard to shelter and appearance. Beautiful landscapes present themselves to view from various points; the ornamental waters in the middle distance—besides rendering the charm that adequate sheets of water always do in such positions—act as huge mirrors when seen from the terraces adjoining the mansion, and reflect the islets and neighbouring ornamental groups of trees and shrubs. Whoever laid out the ornamental grounds the designer was an artist with a master mind, and additions or alterations more recently made exhibit an equal appreciation of the beauty and fitness of things.

The flower garden is large and of beautiful design, and a little below the level of the terraces and to the right of the mansion as one faces it. It has on three sides ornamental trelliswork of iron and wire, forming a lovely promenade covered with Roses overhead. Glowing statements as to the beauties of Drayton Manor Gardens had frequently been made to me, and I always discounted them a little, but I need not have done so, for they are truly beautiful gardens. Chatsworth is grand and magnificent, but for beauty I prefer Drayton Manor. The conservatory

adjoins the mansion, and is a commodious structure. Externally its architectural features are unobtrusive. Nor are the internal arrangements more conspicuous; there is plenty of space for promenading round the fountain in the centre, and the plants are grouped at the sides of the structure. The floor is not laid with blue and red Minton tiles or Italian marble; but it is as comfortable and safe to walk upon as fine gravel, is clean in appearance, and neutral in colour. Growing all over the roof is a gigantic *Acacia mimosæfolia*, from which cartloads of flowers are cut annually. Ferns and foliage plants are grouped about, and a clump of *Bambusa* is in full flower, and its plumes have a beautiful effect.

Planted on the lawns are beautiful specimens of Conifere, varying from 20 to 30 feet in height. These have been planted judiciously in partially sheltered positions; hence nearly every tree is a perfect specimen of its kind. Thousands of Conifers are spoiled through lack of shelter from the prevailing winds. People think that if the soil and climate are suitable for them that is all that is required, but a greater mistake could not possibly be made. Conifers will thrive in almost any kind of soil—but retentive loamy soil is the best for them—and in a comparatively bad atmosphere, if they are only sheltered from the wind; and the best shelter is that afforded by other trees.

Among the Conifers most worthy of notice were *Thujaopsis borealis*, *Cupressus Lawsonianus*, *Picea Nordmanniana* and *P. Pinsapo*, *Cryptomeria japonica*, *Thuja Lobbi* and *Thuja gigantea*, *Abies canadensis*, *Abies Douglasi*, *Larix Kæmpferi*, *Pinus cembra*, *Pinus excelsa*, *Araucaria imbricata*, *Cedrus Deodara*, *Cedrus atlantica*, *Wellingtonia gigantea*, and *Picea nobilis*; these represent the "cream" of the Conifere, and it is a treat to see such a splendid collection. When artistically grouped the effect produced by this class of trees cannot be surpassed by any fine-foliaged plants in the stove or greenhouse. Prominent features at Drayton Manor are the avenues of *Pinus excelsa* with its silvery-grey effect; the avenue, dark and sombre—and in contrast with the sparkling waterfall beyond—of the fine Irish Yews; and the stately avenue of *Araucaria imbricata*, with their walks of velvety greensward.

In the glass structures were good crops of Tomatoes, Cucumbers, Grapes, &c., and hundreds of small decorative plants were in exuberant health. The vegetable and fruit crops in the kitchen gardens were luxuriant and abundant, and testify to the energy and ability of Mr. Mack.—J. UDALE, *Elford*.

#### LILIUM SPECIOSUM AND ITS VARIETIES.

At the conclusion of the first paragraph at page 299 on the above subject, your correspondent, "D., Deal," remarks that his "notes may not be unacceptable to some of the many Lily lovers who read the Journal," and I for one confess that I have read his "notes" with great interest, and the more so when I see that he has an acquaintance with this Lily of which few can boast. Would "D., Deal," mind stating if the species was first called "speciosum," or whether the name "lancifolium" now regarded as erroneous was adopted? Some years ago I had the acquaintance of a very old nursery hand who was conversant with the introduction of *Lilium lancifolium*, by which name he always spoke of this group. I have another reason for asking the question—namely, "The Floricultural Cabinet" for 1838 contains a coloured figure of this Lily under the name of *L. speciosum*, while *L. lancifolium* appears to be first introduced in 1820. But the variety to which I refer as figured in the number of the "Cabinet" quoted, is nearly if not quite identical with the now existing *L. s. Melpomene*, and is thus described, "It is not only handsome on account of its clear deep rose-coloured flowers, which seem all rugged with rubies and garnets and sparkling with crystal points, but has a very delightful fragrance." Then, again, in the "Cabinet" for 1839 there is another variety figured under the name of *L. lancifolium roseum*, but this appears to me to be a mistake, and I am inclined to the belief that it is the true *punctatum* by its very distinct spots, and also by its yellow anthers, which is I believe the true characteristic of *punctatum*, and as far as I know found in no other coloured Lily of this group. This appears to be a later introduction, and reference is given as to its flowering in Messrs. Low's nursery at Clapton, and also Messrs. Loddiges' of Hackney. No notice is taken about calling the one *speciosum* and the other *lancifolium*, and both are referred to as of delightful fragrance. I also notice that "D., Deal," speaks of their "delightful and fragrant blooms," but can this be regarded as strictly correct? I think if it was at all fragrant I should have found it out years ago, and I have been associated with thousands of their flowers this summer. Its non-fragrance I had regarded characteristic of the group, and since your correspondent's notes appeared I have requested several people to tell me whether they could detect any perfume, and to-day, October 17th, I have had a last try for this season on a bloom or two of *Kraetzeri*, but it cannot be regarded as a fragrant Lily, as compared with *auratum*, *longiflorum*, *chalcedonicum*, *Szovitzianum*, *tenuifolium*, *pomponium*, and others. Perhaps "D., Deal," will tell us more of this fragrance, of which I cannot find any mention in Dr. Wallace's "Notes on Lilies," but this I find that the *punctatum* of Lemaire, "Flore des Serres," 276, *albiflorum* of the "Bot. Mag.," t. 3785, and *lancifolium roseum* of "Paxton's Magazine," vol. v., tab. 267 are synonymous.

Will your correspondent be good enough to inform the readers of the Journal if his variety *punctatum* has yellow anthers? This is an important characteristic, but which I do not find mentioned in any work I have. My experience of it is identical as regards its more delicate constitution.

There are not many well defined forms, as stated at page 299, which is to be wondered at considering its free seeding qualities and the number of seedlings raised by the Dutch growers, hence the numerous slight variations of flowers and of general habit. To the list of varieties named I would add *L. s. album præcox*, and *L. s. album novum*. The former is a July flower, pure white, and the latter is also a pure white very distinct flower, revolute when fully open, good vigorous habit, 5½ feet high; this has also yellow anthers, consequently a very distinct white on that account, and a companion to *punctatum* in this particular. This is somewhat singular that these two should be possessed of yellow anthers, while all the others, at least I believe all, have brown or chocolate anthers; it is, however, a most decisive character, and which cannot be well confused.

These Lilies may, as far as winter frost is concerned, be regarded as quite hardy; not so, however, in the biting frosts of spring, which in some localities is very trying to them, and in some seasons disfigure them not a little, but a very slight protection will suffice, such as a few sprays of Laurels or small sticks, or boughs of trees, or if they are planted in the Rhododendron bed, the leaves and branches of these will perform the necessary function; and to protect their blossoms when expanding I make it a rule to remove the anthers as soon as the buds open, and while they are yet hard; the flowers then last for a fortnight and even longer either on the plants or in a cut state, but as pot plants for the greenhouse and conservatory they are unrivalled at their time. To their culture in pots I cannot add much that is new; I must, however, endorse what has been said in the notes referred to, of the great risk in standing them out exposed to all weathers, for this is as dangerous as drying them off. After they are repotted in October stand them on a bed of coal ashes, and cover with about 6 inches of the same material. I find they keep well at this depth, and never become too wet, but if from incessant rains I should deem it requisite I cover with old lights, boards, or the like. I prefer deep planting, and the soil is a rich light loam without peat, though they do not object to it. I see no improvement, however, by using it, and being an expensive item I do without it. Nearly two years ago I planted a large bed, about 200 *Kraetzeri*, to which I gave peat; these I lifted on October 17th, and though they are in splendid style, I see nothing exceptional which is likely to cause me to use it again, since others planted in loam are equally good. I plant deeply with a view to assist the great mass of stem roots annually formed, and I find that by deep planting a greater number of stem bulbs are formed, which is a consideration.

I consider 24-size pots a fair size for good bulbs; under this I do not think there is sufficient room for the proper development of the future bulb, and a little extra room always brings its reward. My plants usually carry from ten to sixteen flowers, and I give weak cow manure and soot water regularly daily in summer time. Charcoal is excellent and never out of place. But why does "D., Deal," in potting leave a portion of the bulb exposed? He most certainly would not do so if he planted in the open ground; why, then, does he pursue it for pot culture, and what benefit does the plant derive? Would it not be as well to supply the whole of the soil at once as well as at two periods? and is it not foreign to the nature of any Lily that its bulbs should be exposed to the ever-changing influences of atmosphere? For my part I never allow any Lily, even if I expect to plant it in a day or so, to be left uncovered for an hour. I cover with bags immediately they are out of the ground, and with fibre or soil directly they enter the shed.—J. H. E.

#### INDIAN EXPERIENCES.

(Continued from page 339.)

WHEN a person is desirous of obtaining a piece of land on the Nilgiris nowadays for the purpose of Tea or Chinchona cultivation he must first of all consult the district maps to see whether the choice is reserved. If there is no reserve he then makes formal application to the collector to have it put up to auction, and after a delay extending over several months the sale is advertised in the district Gazette, and the land is sold. On the day of sale woe to the applicant who is out of favour with the wily native, for, as the auction is public, he may find his discharged cook, butler, or tailor calmly bidding against him. Should the first applicant cease bidding, and the land be knocked down to the native, he generally manages to disappear in a mysterious manner, and the land relapses to the Government, who will put it up again if requested; but as probably the original applicant is by this time disgusted the land remains waste.

Under the new rules land may be taken up without going to auction, but in this case the rent is payable from the date of occupation. This tax on land may not appear heavy to English agriculturists, but when it is taken into account that there is no return from *Chinchona officinalis* (almost the only species now cultivated) until the fifth or sixth year after planting, it will be seen that this tax, combined with the restrictions of sale and the difficulty in actually becoming possessor of the land, is much too high. Chinchona planters have other difficulties to contend with. Grass collected from waste lands—that would otherwise fall a prey to annual fires on the hill sides—for the use of the plantations is taxed, as is also all forest produce used in buildings, except grass used in thatching; so that if two bundles of grass be cut and only one used in thatching, that one is taxed, while the other goes free. As the decortication of the Chinchona trees is only undertaken during the rainy season, fuel is required for drying the bark, which is used at the rate of 3 lbs. of fuel to 1 lb. of bark. This fuel is supplied by the



Government from the neighbouring forests at the rate of 1½ rupee, or 3s. per 1000 lbs., or say 6s. 9d. per ton, the planters cutting, stacking, and removing it from the forests to their plantations. Fuel used in the manufacture of Tea is supplied by the Forest Department on the same terms. It should be also borne in mind that most of the planters on the Nilgiris have had to contend with the mistake of having planted at the outset large quantities of the succirubra species of Chinchona, the bark from which is now of little marketable value, and to rectify this mistake by the substitution of trees which produce more valuable barks, causes great labour and expense. As bearing on this point, I quote the following extract from a letter just received from a Nilgiri planter of great experience.

"Government show great want of thought. They are themselves large growers of Chinchona, and well know that only the richest barks will pay to send home, yet they have just added another tax to the already overtaxed planter in the shape of a grazing duty. For each cow or bullock grazing on Government waste lands the tax is 8 annas, or 1s. per head per annum; buffaloes twice the above rate, while goats are not allowed at all. We have in addition land tax, road cess, village service tax, tax on grass and all forest produce, and between Neddiwattum and Mettapollium railway station, a distance of some forty miles, no less than six toll gates. How we are to carry on under such unfavourable circumstances remains to be seen. Government have again started the manufacturing of febrifuges for the supply of their dispensaries, and by doing this they argue that they are not placing themselves in competition with private growers, forgetting that these febrifuges, if used, displace so much of those manufactured from privately grown barks."

Large tracts of land are now under Chinchona cultivation on the Nilgiris. In addition to private plantations companies have been formed, and in one instance as many as 22 lacs, or 2,200,000 plants have been put down on one property. The plants are usually planted 4 feet by 4 feet apart, and in three or four years the plantation becomes almost a thicket, and has a very pretty appearance. It would seem that the success of Chinchona planting in India is about to prove its ruin. Over-production has brought down prices to such an extent that unless some new use be found for the bark and its extracts, it is feared that many planters may not be able to hold out much longer. Quinine, I believe, is now selling at from 2s. 6d. to 3s. per oz., which ten years ago fetched £1 per oz., or nearly so. So far as the plateau of the Nilgiris is concerned, should planters be compelled to relinquish the further cultivation of Chinchona, the land would still be available for Tea and other products, which is not the case with Coffee land at a lower elevation. At this juncture of the planting industry in South India, it is worth consideration if it would not be profitable to encourage the settlement of European families in such splendid climates as those of the higher ranges of the Madras hills, where abundance of waste land is to be found, and where profitable employment might be found in its cultivation. The speculative system of land cultivation in South India has had a long and exhaustive trial, and has proved beyond question an utter failure. Why, then, not give the allotment or small holding system, a trial which has proved such a blessing to France and many other European countries? Here is a district of Madras possessing a climate admirably suited to the European constitution, where fever, cholera, and other diseases of the plains are unknown, and where Englishmen may work all day in the open without the fear of sunstroke, and where thousands of acres of rich land are lying waste.

The cultivation of Tea has made rapid strides in late years on the Nilgiris, but, as with Chinchona, mistakes of a serious nature were made at the beginning of the experiment. A large area was planted at too great an elevation, consequently the growth of the plant was very slow, and the yield of leaf very unsatisfactory. A large number of estates, however, now exist at elevations of not more than 6000 feet above sea level, and these have given satisfactory yield of leaf, which, when manufactured into Tea, is found to be second to none grown in India, and is not so well known in the London market as it deserves to be. The Tea shrub seems to have fewer insect and other enemies than Coffee, and it is not at all unlikely that ere long a large area of land in Southern India will be under the cultivation of Tea if the present waste land rules are relaxed. Coffee on the Nilgiris is perhaps the finest in South India. Grown at a greater elevation than the neighbouring districts of Wynaad and Coorg the trees present a much more sturdy and robust appearance, and are longer lived. Elevation, however, has not been a protection against the ravages of leaf disease, at the same time the after effects on the plants do not seem to be as severe as on estates at a lower elevation. There is a good deal of Coffee on the Nilgiris grown at an elevation of from 4500 to 6000 feet, and on one estate I have seen Coffee growing up to 7000 feet elevation, and where the trees in some seasons were cut by frost. Coffee from these elevations is of excellent quality, and fetches high prices in the London market. Before the advent of leaf disease the numerous Coffee estates situated near the top of the Coonoor Ghaut, or pass leading to the low country, were a splendid sight. One side of the valley was clothed with the dark green of the Coffee shrub for several miles in extent, and as at this elevation drought had not such an effect upon them as on trees at a lower elevation, they were always fresh and green winter and summer. The trees were of immense size, and yielded under high cultivation splendid crops. In addition to this the climate is good, and the surrounding scenery superb, making a planter's life in this locality truly enjoyable.

A few words regarding the inhabitants of the Nilgiris may not be

uninteresting. The tribes are five in number—viz., Todas, Badagas, Irulars, Koorumbers, and Koters. The first named is, perhaps, the most interesting of the five. They are said to have been the first that settled on the hills, but whence they came is a mystery, as there is no other native tribe in South India bearing the slightest resemblance to them in physical appearance, language, or customs. They are fine handsome men with glossy black hair and beards. They never wear any covering for the head save what Nature has provided. Their only garment is a thick cotton plaid or toga, which is thrown over the right shoulder, falls over the left arm, and covers the body almost to the knees. This they wear night and day, and it is said the Toda never washes from the cradle to the grave. They number under a thousand souls, and their "munds," or hamlets, number about a hundred scattered over the plateau. A Toda's dwelling is a hut resembling in appearance the top of an English waggon of the olden time placed on the ground. It is thatched with grass and shaven in a wonderfully neat manner. They are a pastoral race, and of a very peaceful character. They possess large herds of magnificent buffaloes from which they derive excellent milk. Until very recently they never performed work of any kind, save that in connection with the grazing of their herds, &c., but now, I believe, some few are willing to work on the Chinchona plantations. This tribe shift their hamlets from time to time, and, what is very curious, invariably choosing spots for the erection of their huts of the most beautiful and picturesque description, close to some charming wood and running stream of the purest water. Their huts have no windows, and the doors are never high more than 2 feet, so that the occupiers have to enter on "all fours."

The Badagas are the most numerous tribe on the Hills, and are the original cultivators of the soil. These men are largely employed by Europeans as "estate coolies," and are excellent workers. They are supposed to have come from the southern parts of Mysore and Canara, being allowed to settle by the Todas, who were at that time the lords of the soil, upon conditions that they should yearly supply to their masters a certain number of measures of grain of various kinds, which contract is carried out most religiously to the present day, although originally entered into doubtless some centuries ago. The Badaga villages are neatly built, many of the houses being of brick and roofed with tiles. They are an industrious tribe, and cultivate many roots and grains, including Wheat, Barley, Peas, Onions, and Potatoes. They possess large herds of cattle, which are, however, of an inferior breed. They frequently plough with a bullock and a buffalo, and according to their proverb, "the bullock pulls for the hill side, and the buffalo for the swamp." The Poppy is cultivated by the Badagas, and the brown juice dried and solidified, is eaten to some extent, and sold. This tribe is sub-divided into numerous castes, the highest being strict vegetarians, whilst the lower grades will eat any flesh they can get, save that of the cow. They differ in complexion from very dark to very light.

The Koorumbers are a tribe of mountaineers not very numerous. They are regarded by the Badagas with great superstition, the latter believing that the Koorumbers have possession of certain magical arts, which they can use with fatal effect against whomsoever they choose. The Koorumbers are regarded as priests whose presence is essential at every sacrifice, and whose occult power alone can remove calamity. They are paid in cash and kind by Badagas and others, who do not scruple to pay them after another fashion when they fail by means of herbs, gums, charms, &c., to cure the sickness or take away the curse. When Badagas begin to break up the fallow ground the Koorumber must slay a kid to propitiate Ceres (Bhudévy), hold the first plough at starting, and throw the first handful of seed. So also, when crops ripen to the sickle, the Koorumber must cut the first sheaf.

The Koters are a race of people who are said to come next to the Todas in priority of occupation of the Hills, and of all the Hill tribes are the most clever. The Koter is a curious character, or rather combination of characters. He is blacksmith, whitesmith, goldsmith, silver smith, carpenter, tanner, currier, roper, potter, barber, washerman, and cultivator, in fact "Jack of all trades, and master of none." Yet he is master of the situation, equal to it, and has been so for generations. The other tribes cannot possibly do without him. The Koter is a man of no caste, corresponding with the pariah of the plains. He will eat almost anything. His habits are dirty in the extreme, and his village is constantly surrounded by immense flocks of vultures, kites, and crows.

—PLANTER.

(To be continued.)



THE WEATHER in the northern part of the kingdom has been rather wintery, snow having fallen in several districts. In the neighbourhood of London there have been several sharp frosts, 10° to 14° having been registered, but there has been no snow, and the weather continues dry and bright in the daytime.

— WRITING under date, October 18th, a correspondent states that

though frost has cut plants badly in low-lying districts around Sheffield, in more elevated localities Dahlias are flowering freely, and bedding Geraniums are also still bright with flowers. Chrysanthemums are looking better than usual, and good blooms are expected. They are opening very kindly.

— A CORRESPONDENT, "C. J.," desires to know where he can get ordinary sized flower pots glazed on the outside, within reasonable distance of Croydon, Surrey.

— THE NATIONAL CHRYSANTHEMUM SOCIETY held a general meeting on Monday last at the "Old Four Swans," Bishopsgate Street, London, when in addition to the usual business forty-seven new members were elected and five Fellows. It was announced that £72 had been paid for prizes at the September Show, and that twenty-two silver medals, eighteen bronze medals, and sixty-eight certificates had been issued to affiliated societies. The prizes from the Veitch Memorial Trustees have also been received.

— MR. R. P. BROTHERSTON sends us a box of SPOTTED AND STREAKED ANTIRRHINUM FLOWERS, exceptionally varied and beautiful. They range from nearly pure white with only a few streaks to heavily rose and crimson splashed flowers of bold appearance. The light forms are extremely delicate, and the others are proportionately bright. Our correspondent remarks—"I do not think these are at all common, though they well deserve to be grown. This strain came originally from an amateur florist, and I think I have improved it considerably in the course of the years it has been in my possession. Four lines of it, each 120 feet in length, have been very attractive during the summer and autumn. The rose-coloured varieties with salmon orange and yellow throats are particularly effective."

— ON the evening of the 18th October, in the schoolroom at Carlton, the CARLTON-IN-LINDRICK ROSE SOCIETY (the Rev. Mr. Foxley in the chair) held a special meeting, to hear a paper read by Mr. Duncan Gilmour, jun., of Sheffield. The subject was "Some Hints on Rose Culture." There was a fair attendance. After the lecture many questions were put by various members, and some information elicited. Among others present Mr. J. Mallender, the veteran Rose grower and able head gardener at Hodsock Priory, and his opponent, Mr. H. V. Machin of Gateford Hill, both large growers of Roses, added much interest to the proceedings by their remarks and queries. The meeting closed with the usual vote of thanks to the Chairman and Mr. Gilmour.

— PLANTING ROSES—A WORD IN SEASON.—"I have no doubt," writes Mr. D. Gilmour, jun., "that thousands of people visiting our great and little flower shows this last summer registered a mental vow to plant Roses, so as to secure flowers in their own gardens as soon as the season came for so doing. Nine-tenths of these people, with minds full of good intentions, have made no preparation whatever towards having the ground ready, neither will they take any step in the matter; some from ignorance, but the greater number from that familiar way we, most of us, get into, of putting off until next week what we ought to do now. Truly is 'Procrastination the thief of time.' I am asked on the average at least once a day by somebody, 'What is the best time to plant Roses?' My reply is, and I wish I could give it in a voice that should ring from one end of the kingdom to the other, 'Now is the time;' that is, now is the time for those who desire good flowers and satisfactory growth next season. But for those who can afford to wait about eighteen months after planting for flowers and growth, or who wish to look on at the struggles a Rose will make for dear life all through the summer after being planted late—who, in a word, do not mind wasting a whole year in this short feverish life of ours, the proper time will be in the spring, and the later the better."

— A CHRYSANTHEMUM SHOW AT THE PEOPLE'S PALACE, MILE END, is to be held on November 16th, 17th, 18th, and 19th, under the management of Mr. W. Earley. A large display is expected, as assistance will be rendered by many amateurs in the south of London.

— MR. JAMES HICKS, The Gardens, Ravenswood, Heaton, Bolton, one of the Secretaries of the BOLTON AND DISTRICT CHRYSANTHEMUM SOCIETY, sends us a schedule of the first Show, to be held in Bolton Town Hall, on November 17th and 18th, and observes, "Although our prizes are not large, we hope to get a good collection of plants and flowers together." We hope so too, and commend the prudence that is

apparent in commencing on a moderate scale involving small risk of failure.

— THE WIMBLEDON AND DISTRICT ROYAL HORTICULTURAL AND COTTAGE GARDEN SOCIETY will hold its autumn Show of Chrysanthemums and other plants and fruit in the Drill Hall, Wimbledon, on November 17th. Dr. George Walker and Mr. J. Lyne are the Honorary Secretaries.

— GARDENING APPOINTMENTS.—Mr. Charles Deane, late gardener to C. P. Stewart, Esq., Silwood Park, Ascot, has been appointed gardener to the Earl of Essex, Cassiobury Park, Watford. Mr. G. Abbey, jun., recently foreman to Mr. Gilbert at Burghley, has been appointed to succeed the late Mr. Harding as gardener to J. D. Galpin, Esq., Bristol House, Putney Heath.

— We have received the schedule of the HAVANT CHRYSANTHEMUM SOCIETY, the fourth Exhibition of which will be held on November 3rd and 4th. Mr. N. Fuller, The Gardens, Idsworth, Horndean, is the Secretary.

— BOUVARDIA PRESIDENT CLEVELAND.—Looking into the Bouvardia house in Messrs. Veitch's nursery at Chelsea, in which all the best varieties are represented, attention was at once rivetted on the new American introduction above named. It far surpasses in richness all others of the genus, the colour of the flowers being rich velvety scarlet, not brick red. Few scarlet Pelargoniums or Begonias are brighter than this new Bouvardia, which we believe is also to be found in other trade collections, and if we mistake not it will find its way into every garden in which Bouvardias are grown, and also become a popular market favourite. The plant is a free grower and trusses well, only being exceeded in these qualities by the very floriferous and extremely useful Priory Beauty, which was distributed by Messrs. Veitch a few years ago, and is in great demand for decorative purposes.

— BEGONIA JOHN HEAL.—In the establishment above mentioned we could not fail to be impressed with the unquestionable distinctness and great decorative usefulness of this new variety. It was raised in the nursery from *B. socotrana* crossed with a tuberous Begonia, and possesses the roundish foliage of the former, and the flowers, much reduced, of the latter parent. The plant is dwarf, and so free that it commences flowering in 3-inch pots. The blooms are an inch or so across, rich rosy carmine in colour, and borne in loose panicles. They possess the merit of hanging till the petals decay, and are not easily shaken off the plants in the manner that is common to most forms. Plants a foot high in 5-inch pots are highly attractive and appropriate for various decorative purposes, and the flowers can be used in a cut state. This new Begonia far surpasses *B. Ingrami* and other dwarf varieties that flower freely in the winter. It was certificated when first presented to the Floral Committee at South Kensington, and the bright and elegant appearance of the plants now afford sufficient evidence of the honour being well merited.

— RESTING AMARYLLISES.—We entered the large house that presents such a magnificent effect in the spring to find the plants being dried off for the winter. They are grown in 5 and 6-inch pots, and root over them into the plunging material early in the season. This induces strong leaf-growth, and the ripening process commences. No water is given after August, and a dry atmosphere is maintained. Eventually the pots are withdrawn, and the roots outside them allowed to perish, as having done their work; the leaves gradually wither, and when changed in colour and limp are cut off as having then done their work also, the bulbs remaining as bare and as dry as Onions, but kept in the pots till the time arrives for taking them out, adding fresh soil and starting them in the spring. The old plan of preserving the foliage in the winter has been fairly and fully tried and found wanting—hence is discontinued, with what results visitors know who inspect the collection when the plants are in flower. The routine may be summarised thus—Steady growth with little water in early spring till flowering; warm, genial treatment, with sufficient water to produce quick and good foliage in the summer; a roasting autumn, or all the sun possible; and complete rest in winter.

— MR. W. WENMAN, The Gardens, Hieleton, Doncaster, sends for our inspection a bunch of MARIE LOUISE VIOLETS, and observes:—"When we were lifting plants from the open ground and planting them in frames we had a few to spare, and potted them in 6-inch pots and

placed them on shelf in cool vinery, hoping to get a few flowers from them in frosty weather when the frames could not be opened. They are a mass of bloom and buds now." The flowers are very good indeed, but we prefer not to have their delicate fragrance overpowered by a fringe of sprays of the powerful *Lippia citriodora*; to others, however, the mixture might possibly be acceptable.

— At a recent meeting of the members of the WAKEFIELD PAXTON SOCIETY, Councillor Milnes, one of the Vice-Presidents, was in the chair, and there was an average attendance. Mr. T. L. Moseley of Huddersfield, a well-known naturalist, and who has been engaged by the Huddersfield School Board to deliver lectures on natural history, gave a long and interesting address on "Farm and Garden Insects: their Deleterious and Beneficial Effects on Produce." The lecture was admirably illustrated by a collection of sketches of insects of various kinds, which were exhibited by means of a magic lantern. After a little discussion a hearty vote of thanks was awarded to the lecturer, on the motion of Mr. G. Parkin, seconded by Mr. E. B. Wrigglesworth.

### MEMORIES OF A TOUR.

LET no one expect a series of elaborate descriptive notes of the nature of the series so ably contributed by Mr. L. Castle on parks and gardens in the north of England, or the penalty of disappointment will assuredly be incurred. I have visited so many gardens in my time, and filled so many pocket books with notes, many of which have never been transcribed, that I resolved to take it easy in my last ramble, trusting to memory for a few jottings (that may not be entirely uninteresting to all readers), save that on a waistcoat pocket tablet a few lines of poetry were inscribed from a temple at Chatsworth, and an inscription from a stately column on the heights of Lincolnshire.

¶ The "heights" of Lincolnshire will sound strangely to those readers who have pictured that county as a great expanse of marsh and fen, as level as the sea, and only one remove from a swamp; but they will find something very different if they call on Mr. Tillyard at Brocklesby, and walk thence to the Pelham's pillar that was erected by one of the Earls of Yarborough commemorative of the planting of upwards of 12,000,000 trees on the fine estate. This was not, however, the commencement of my tour, or the first resting place in it, but nearly the last.

It has in some respects been a tour of extremes—namely, from the extreme west of England and a little beyond it, to the extreme east; or from points of vantage overlooking Swansea Bay on a day that was misty, and the waters of the German Ocean on another day that was clear. It embraced in its range the largest city in the empire and the smallest, and involved the traversing of roads from 1000 or more feet above the sea to 50 or more feet below it. It afforded opportunities for inspecting crops in poor soil and in rich, in deep soil and in shallow, in trenches and on ridges. It brought under review some 10,000 Vines growing in a field and the crop ripening for the vintage; then, as a change, a dozen or so in the greenhouse of an amateur from which all the bunches except a few at the top had been cut by thieves. Vines of all ages from one year to a hundred have been examined and chatted over. Grapes "on the spur" have been admired that would have delighted Mr. Abbey; and others on something else, we will say on the "cane," that would have made "Experientia docet" jump for joy, and claim them as a triumph in support of his views. If those contestants had been with me I believe I could have made each of them believe in the other, and effect a reconciliation between them in a manner that I have also seen—the swapping of aprons.

I have further had the pleasure of impression on the memory Vines in 7-inch pots bearing at the least 10 lbs. of splendid fruit, and others ten times their size planted out and bearing next to nothing. Camellias growing in gravel walks in the open air have gladdened by their luxuriance, and others in pots have depressed by their dried and roasted appearance in hothouses. Orange trees 300 years old have spread their fruit-laden branches above us, and Lemons, as happy as Lemons could be, were passed on the back wall of a vinery growing and fruiting abundantly in the shade. Pears are remembered on the free stock with their branches breaking down under their load of grand fruit, and others on the Quince prematurely dwindling away; and not to be forgotten were plantations of Apple trees and Osiers planted together by the acre, the land in these days of falling prices being thereby increased in a few years more than 100 per cent., while among other things photographed on the mind are yellow *Calceolarias*, perfect cones of gold, 8 feet high, yet not a year old from the cuttings.

There may be some disadvantages in trusting to treacherous memory, for it is almost certain that some things, and it may be several, will be omitted that are worthy of record, but there is a set off to this, regarding the matter from a selfish point of view, for if anything is told at once there is no excuse to go again; and the welcome we have received, for there were a pair of us, was so cordial everywhere, and the hours spent with friends so pleasant as to make us look longingly forward to the possibility of another visit for picking up the fragments. There is also an advantage arising from forgetfulness, regarding the matter from a point of view that is not selfish—namely, that other visitors may find plenty to say that has not been said in a mere skimming over the sur-

face of a few gardens, most of which have been heard of before and I will be heard of again.

We left the largest city in the empire, London, on September 15th, and was very near the smallest, Llandaff, the same night. Gliding along the Great Western Railway we had a passing glance at Messrs. Veitch's extensive trial grounds and Rose and fruit nursery at Langley, the beds and lines of autumn flowers being still gay; the well known and well furnished nurseries of "Turner's of Slough," and the great blocks of colour, crimson Asters being most glowing, in the level tract of land of Messrs. Sutton's of Reading. Onwards through the park-like scenery of Berks, we search for the historical white horse on the steep hillside, not far distant from Uffington and Shrivvenham, but failed to find it, then drew breath at Swindon. Beyond that an impression possessed us that we were in or near what we called "Igguld-n's country," and we thought his lot had fallen in greener places than those left behind us—greener trees, and hedges, and fields, as if the drought had been less exhausting than in some other districts. We thought of him, as we had previously seen him industriously working, for in spite of himself and his critics he does wonderfully well with the resources at his disposal, and we vote him an excellent gardener, an esteemed friend, and a genial man.

We crawl on, losing time as only trains can sometimes, and were forcibly reminded of the difference between an express and an ordinary train as defined by a son of Erin on a former occasion—"And shure, sorr, the only difference that I can see is the ordinary trains stop at all the stations and the expresses between them." However, we reached Bath, regretting our inability to see Mr. Chaffin's Grapes and their accomplished, and as "D., Deal," has truly described him, very modest grower. It is a little singular that we are apt to admire virtues in others that we do not ourselves possess. I studiously try to be as modest as possible, but somehow fail to reach the standard of Mr. Wm. Taylor. I hope he will not chide us for not giving him a call. We push on to Bristol through a downpouring rain—as dismal an outlook as could be imagined for a holiday in the country; and soon after leaving the murky town find ourselves sliding town into the Severn tunnel—one of the greatest works of modern times, a submarine monument of trade enterprise and engineering skill. The tunnel slopes to the centre, and the timid might fancy the hissing that is heard is the water rushing in from above us, but it is only the brakes checking the downward movement of the train. The crown of the arch we were informed by a fellow passenger, who appeared to be no stranger to the locality, is 40 feet below the bed of the Bristol Channel, and the length of the tunnel 4½ miles and 7 chains. We were thus at the least 50 feet below the level of the sea. There was nothing uncomfortable in passing "under the water," though after twelve minutes' experience of it daylight was welcome on the other side.

Our course was next through a generally flat and not highly picturesque district, a level expanse of pastures on the left or channel side, but the water not visible, and on the right higher and drier ground with whitewashed homesteads dotted amongst the trees, and here and there a village, looking substantial and comfortable. Passing through Newport we soon arrived at Cardiff, and were greeted on the platform by Mr. Pettigrew and whisked away to his pleasant and commodious dwelling for our first night's rest in Wales.—A TOURIST.

(To be continued.)

### CHRYSANTHEMUM NOTES.

AS soon as October mists and frosty nights announce the arrival of autumn weather the Chrysanthemum interest begins to revive; exhibitors watch the slowly expanding buds with some anxiety, and prepare their plans for the approaching campaign. An effort has been made by the National Society to awaken the Chrysanthemum enthusiasm at their early show in September, but the attractions are then divided with the Dahlias, and the latter have hitherto had somewhat the best of it on these occasions. The early flowering Chrysanthemums are useful garden plants, but they come at a time when we still have abundance of flowers both indoors and out, and consequently want the charm that attaches to the November varieties. But there are now so many early flowering Japanese forms, which expand freely in October, that there is a constant succession from September to the end of the year. The incurved varieties are, however, the true November flowering type, and with them come most of the leading exhibition Japanese varieties.

### THE SHOWS.

There is no sign of a diminution of interest in Chrysanthemums—on the contrary, there appears to be a decided increase both in the number of growers and admirers. Over sixty exhibitions have been announced to be held this year, and the majority of these take place in the first three weeks of November. If we consider the number of exhibitors and visitors at these shows, the total amount expended in prize money, and the receipts for admission, it will give an idea of the popularity of the autumn queen. Nor is this confined to one portion of England. From Alnwick to Portsmouth and from Cornwall to Kent, nearly every important town or district has its annual show, several being added to the list this year. Two have, however, been withdrawn, from lack of funds rather than lack of interest—namely, Richmond and Stoke Newington. It is difficult to understand why the Richmond (Surrey) Show should not have proved more successful from a financial point of view. The district is a good one; there are numbers of experienced cultivators within easy reach of the town; the position where the show was held was con-



venient for all concerned, and what is also very much to the point, the Society has an excellent Secretary in Mr. Ford. It is said, however, that the Jubilee demands have been so great upon the purses of the inhabitants that it was feared insufficient support could be obtained, and rather than incur a possible heavy deficit in the year's accounts it was decided to discontinue it, at least in the present season. Many will regret that the Stoke Newington Show has been stopped, as it was—in name at all events—of much interest historically. The first Stoke Newington Show was held in 1846, long before the Chrysanthemum had become as popular as it is now, though the Society which has continued the shows in recent years is only a section of that which started them, the stronger portion having developed successively into the Borough of Hackney and the National Society. Still, for incurved blooms and specimen plants the Stoke Newington Show had retained much of its former fame.

#### CHALLENGE CUPS.

The chief shows of the year will probably be those at Southampton, the Crystal Palace, Kingston, Westminster, Portsmouth, Birmingham, Hull, and Liverpool, at all of which substantial prizes are offered, besides several challenge and other cups. The contests at Kingston, Portsmouth, and Hull will be regarded with special interest, as at each there is a challenge competition as yet undecided. Mr. C. Gibson, Mr. E. Molyneux, and Mr. Mease were the last year's winners, and if they are again successful will be the heroes of the season.

#### CERTIFICATING NEW VARIETIES.

It is as yet too early to say much about the novelties of the present season, but some that were brought into notice last year are gaining rapidly increasing favour already. Unfortunately, some of the French growers have become rather reckless and are sending out so-called new varieties by scores, evidently without fully testing their merits in comparison with the numerous well-proved varieties already in cultivation. This will do much injury to both sellers and buyers if unchecked, and necessitates great care on the part of British nurserymen in announcing the continental novelties before they have had a season's trial in this country. We have seen a collection of fifty new varieties under the best cultivation, a large proportion of which were much inferior to other varieties of a similar type already grown here. In checking such novelties, the Floral Committees of the Royal Horticultural and the National Chrysanthemum Societies can do good service. The latter body has become much more cautious in the award of certificates that at one time were scattered very freely, but at Kensington, owing to the peculiar constitution of the Committee, strange awards are made for exhibits of a special character. It was a matter of surprise to many recently to find that the Japanese L'Africaine had been honoured with a certificate there after being so many years in commerce and so little valued. In a mixed Committee which has to deal with plants of widely different character the opinion of specialists in each should have the greatest weight, but this does not seem to be followed, for more than one of the best Chrysanthemum Judges present at the meeting in question were opposed to granting a certificate for the variety mentioned.

#### CHRYSANTHEMUMS AROUND LONDON.

□ A summary of the prospects in the north has already been given, and a few notes on the collections around the metropolis will indicate the probable character of the southern competitions. It must, however, be remembered that the plants generally seem to be later than usual, and much will depend upon the weather during the next fortnight. The hot dry season has been favourable to the thorough ripening of the wood, but has necessitated close attention on the part of cultivators, especially in the supply of water, and neglect in this matter in such a summer as the past would mean positive failure. Plants generally are most satisfactory, the growths well developed and matured, with abundant good foliage, the buds large and expanding evenly. Belle Paule is again troubling some growers a little, but as one of the most experienced remarks, "It is so distinct and telling on a board when in good condition that it is worth all the attention it requires." There are few complaints respecting the general stock of plants and varieties, and the prospect is encouraging to the majority of exhibitors.

#### CAMBERWELL.

At the Lilford Road Nursery, Camberwell, Messrs. Davis & Jones have an excellent display, and as their plants, unlike most others, are somewhat earlier than usual, there is a number of blooms out now well showing the characters of their respective varieties. The principal show house is a lofty span-roofed structure 65 feet long by 30 wide, and in that the plants are arranged in a central bed, Japanese mostly on one side, the varieties of similar colour together, incurved on the other side, and miscellaneous varieties round the sides. Five other span-roof houses are also filled with Chrysanthemums in various stages, but about 3000 plants are grown in large pots for specimen blooms, the others being for stock or to afford blooms for cutting. All the best varieties in the different sections are grown together with the novelties which come in such numbers from the continent every year, but at the present time the chief portion of the display consists of Japanese. Prominent amongst these is Edouard Audiguier, which made its appearance last year, but we only saw one really good bloom of it, for which a certificate was awarded by the National Society. This year it has come in admirable form both from crown and terminal buds. The plants are from late struck cuttings, are 3 to 4 feet high, and have three to six good blooms or buds each, every one of which is expanding freely, and indicating by the number of the florets the size the blooms will ultimately

attain. The habit and constitution of this variety are exceptional, the growth strong, the leaves large and dark green, the stems being of a deep purplish tint, so that the plants are readily distinguished even when not in flower. The bloom represented in fig. 47 was from a crown bud, and measured 6 inches in diameter by 5½ deep, the florets crimson maroon with a silvery reverse, twisted and drooping, showing the lighter under surface. From terminal buds the blooms are intense maroon tint, very rich, but with scarcely any of the crimson noticeable in the crown bud blooms. Large blooms would be extremely effective in an exhibition stand.

The early variety, William Holmes, which was honoured with so many certificates last year, is well maintaining its credit as a fine variety, but is too early to be of much use to exhibitors, though some of the blooms would not disgrace any stand, and the colour is very rich. Carew Underwood is notable for its great size, some blooms being 10½ inches across from tip to tip of the florets; they are also filling up well, the colour a peculiar rosy bronze hue, yellowish in the centre. Phœbus deserves especial praise, and it is certainly one of the best Mr. Salter has raised. The blooms are of fine shape and size, the florets slightly recurving, imparting a beautiful outline to the blooms, and the colour—a rich golden tint—is unsurpassed. This should constitute a telling variety in a stand. Ormonde, a new Japanese of this year, is not fully out yet at Camberwell, but some early blooms of it recently exhibited, though rather thin, were promising, as the character is so distinct. It opens of a reddish bronze hue gradually turning to yellow, the florets long, drooping and twisted. With a little more substance this would make a capital addition to the list, and we shall expect to see it much better another season.

A small-flowered early Japanese, Roi des Precoces, is, of course, not an exhibition variety, but it will probably become one of the greatest favourites as a decorative plant for cutting, and in this respect it will take a place amongst the most useful. The blooms are neat with spreading slightly fluted florets, of a brilliant red colour, almost scarlet. They are produced in great numbers during October, at a time when they are most valuable for harvest decorations, and arranged with white flowers they have an excellent effect. It has already attracted the attention of growers for market. Alexandre Dufour is better known, of somewhat similar habit, but bearing larger blooms, the colour somewhat purplish crimson. Of such varieties as Mdlle. Lacroix, Lady S. Iborne, Elaine, La Triomphante (very fine), Madame C. Audiguier, Mandarin, and Comtesse de Beauregarde, there are numerous plants, and Mr. J. Laing is coming very fine this year, as it is elsewhere.

It is too early to say anything about the incurved except that the plants are in capital condition with good buds, and Jeanne d'Arc is promising remarkably well. Amongst the Anemone Japanese Fabien de Mediana is expanding some large blooms, the charming Mdlle. Elise Dordan, the bronze red Alice Butcher and its parent Lyon being notable amongst the Pompons. But for several weeks to come there will be much of interest to be seen at Lilford Road, which, it may be added, is reached in a few minutes' walk from Loughborough Junction on the Ludgate Hill and Victoria line.

#### PUTNEY.

The St. John's Nursery at Putney will, no doubt, be visited by many admirers of Chrysanthemums this year, for Mr. Stevens has one of the best shows he has yet obtained, and under the management of Mr. C. Orchard several highly effective groups have been formed. Something like 6000 plants are grown, the principal houses devoted to them being two span-roofed structures respectively 52 feet long by 22 feet wide and 54 feet long by 26 feet wide, besides a conservatory attached to the dwelling house, which formerly sufficed, but has been found much too small for the purpose in recent years. Large numbers of varieties are represented, the plants have been thoroughly well grown and are bearing substantial buds and blooms, though the majority of the latter are as yet far from fully expanded. Of Mdlle. Lacroix, however, there is a capital display, and the grand blooms recently shown both at South Kensington and Westminster are only examples of many more in the nursery. Elaine has also afforded a fine show, some hundreds of large and pure blooms having been cut within the past week or two.

Mr. Orchard has repeatedly given proof of his skill in the arrangement of groups of plants at shows and in the conservatory at Coombe Leigh, Kingston, and the large banks of plants at this nursery have afforded him an excellent opportunity for producing similar effects. When the blooms are more advanced these groups will constitute an important feature well worth a visit. A few of the new varieties are expanding freely and indicate their characters, some far surpassing last year's expectations concerning them. Notable in this respect is Mrs. J. Wright, which was certificated last year at the Crystal Palace, but was then thought rather too small to make a first-rate exhibition variety, though well fitted for the front rows in stands on account of its purity. But this year the blooms have come of excellent size, full, deep, and well proportioned, though they are not all pure white, some being blush tinted. It is, however, quite distinct and a very handsome variety that will soon become a favourite. Edwin Molyneux is another Japanese variety, which was rather disappointing last year, but has greatly improved, and will probably take its place amongst the best flowers of the year. It is of the Comte de Germiny habit, with broad incurving florets, an intense crimson on the upper surface, with a bronzy gold reverse, and the only defect at present visible is that the florets do not seem likely to unfold sufficiently to permit the rich upper surface being readily seen. Possibly this may be avoided, and then it will be a very

telling flower on a board. A Japanese variety sent out by Messrs. Cannell & Sons under the name of C. Orchard is also of the Comte de Germiny type and rather promising. William Cobbett, for which Mr. Stevens obtained certificates recently at South Kensington and West-

Amongst the general stock the following are advancing favourably:— Henri Jacotot (some blooms over 6 inches in diameter), Carew Underwood, Striatum Perfectum, Margot, Salmoneum plenum, Madame de Sevin, Fernand Feral, Lakmé, Belle Paule, and scores of others. Of the



FIG. 47.—CHRYSANTHEMUM EDOUARD AUDIGUIER.

minster, is a variety of good substance and delicate colour, while another of a similar type, La Villat des Prunes, is almost intermediate between that and Margot. Maiden's Blush, which has become an established favourite, maintains its good character; and several others that have been sent out from this nursery are equally satisfactory.

inured we shall have occasion to speak later on; at present Mr. Bunn is almost the only variety in its best condition, and of this there are some very deep blooms. Apart from the Chrysanthemums, it must be added that four span-roofed houses full of double white Primulas constitute a stock that could be scarcely equalled, all healthy plants.



## MORDEN PARK.

The residence of J. Wormald, Esq., where Mr. C. Gibson has gained such fame as a Chrysanthemum grower and exhibitor, is within half an hour's walk of either Morden or Lower Merton stations on the Wimbledon lines from Croydon, London Bridge, or Ludgate Hill; and this year Mr. Gibson has equalled the best of his former efforts to produce good plants and blooms. About 500 plants are grown, 400 of these being incurved and Japanese, the others chiefly reflexed, Pompons and Anemones. Three lean-to vineries, 140 feet long, are devoted to the plants, and as some of the Vines still retain a portion of their foliage shading has not been necessary up to the present, though preparations have been made to afford it should the weather become unusually bright. During the summer the plants were placed in a portion of the gardens well exposed to the sun, but adequately sheltered from winds, and received every attention in watering. They are now fine vigorous specimens without a suspicion of grossness, the wood and foliage well developed, the latter clothing the stem to the base in the majority of cases. The blooms too, where open, are of excellent substance, while the numberless expanding buds are coming freely without any tendency to deformity or irregularity. Much of his success Mr. Gibson attributes to a good start and careful treatment in the early stages. He has fully detailed his system in the "Chrysanthemum Annual," and remarks respecting the early stage as follows:—

"In growing the Chrysanthemum for exhibition a great point is gained by a good start. Take great care to select the best cuttings possible—vigorous and healthy, rejecting the slender and weakly ones; also to be careful to have them true to name. A little extra time spent in taking cuttings is more than repaid afterwards; a strong cutting grows into a strong plant, but with a weakly plant the season is spent before it has gained full vigour with sufficient reserve strength to develop blooms satisfactorily. The time most preferred by myself for inserting cuttings is the end of November and the beginning of December. We place them singly in small 60-size pots, arranging them in a cold pit. The pit should be in a position open to the sun, and at an angle to obtain the greatest amount of light. Mine is used for Cucumbers or Melons during the summer, and a layer of ashes a few inches deep is placed on the soil, so that the cuttings are about 12 inches from the glass at the back and 6 inches in front. The advantages of a cold frame are the cuttings do not droop, so, of course, have no check; and the cold frame is more in character with the hardy nature of the plant. If I had a frame but no brick pit, I would pack 12 inches of long litter or bracken round it, so that a covering of mats, according to the state of the weather, would be a sufficient protection."

It would be unnecessary to enumerate the varieties that are well represented at Morden Park, for that would mean naming the great majority of those grown. Incurved varieties have received much attention, and the plants are very satisfactory. Earlier in the season, when the plants were out of doors, a long row was formed of the "Queen family," and very seldom could such fine even specimens be seen. The promises they then gave are being fulfilled, and we shall expect to see some admirably finished blooms in Mr. Gibson's stands this season. Bronze Queen is opening a good colour, and if it attains sufficient size will make a welcome addition to exhibition varieties. At Morden Park it looks better than we have hitherto seen it, but is not fully developed. Capital blooms of Prince Alfred are advancing, also of Jeanne d'Arc, Lord Wolseley, Princess Beatrice, Barbara, Novelty, Mr. G. Glenny and Mrs. G. Rundle. There are some exquisite blooms of the two last-named, very fine for those varieties, remarkable for their purity and substance. Refulgence is also unusually good, especially from the crown bud, as in several instances blooms from terminal buds are thinner, though a few later blooms are necessary. Mrs. Norman Davis is fully maintaining the good opinion formed of it last season, but grown upon the large bloom system it is coming earlier.

Greater numbers of Japanese are open, and these are equally satisfactory. They vary in height from 6 to 9 feet high, the tallest being Thunberg, Madame C. Audiguier in excellent condition, and Belle Paule. Of the latter the blooms from terminal buds look the most promising, the crown buds not proving quite so "kind" this season. Some that remained hard for a long time and seemed very reluctant to open are now advancing rapidly, and when in this stage a few days make an astonishing difference in the blooms. Very notable amongst new and recent varieties is Album fimbriatum (Laing), which has pure white florets fimbriated at the points, but develops into a bloom of the Elaine build. Snowstorm is a beautiful variety, pure white, large, and, as Mr. Gibson has it, possesses much to recommend it as an exhibition bloom. Moonlight, yellowish white, is also expanding of great size. Such names as these might be increased, for they certainly possess more interest and more meaning than nine-tenths of the French titles, and the ordinary English names are not much better. Ralph Brocklebank is advancing steadily, half-opened blooms being of good size and a rich golden yellow colour. By the way, someone recently described this as a sport from Princess Teck; it is, however, scarcely necessary to remind readers that it is a golden sport from Meg Merrilies, a Japanese sport from an incurved variety would certainly be a novelty. Phœbus is excellent also, and in contrast with Peter the Great and Agréments de la Nature, which are near the plant, its superiority is instantly apparent. The colour is richer than the first, and in form the bloom surpasses both. Triomphe de la rue des Châlets, Comte de Germiny, Pelican, M. Delaux, Hiver Fleuri, M. Ardenc, Maiden's Blush, Dormillion, are all represented by large blooms, and there are some fine Japanese Anemones developing freely, especially Sœur Dorothee de Souille, and Fabien de Mediana. Such

reflexed as Chevalier Domage, King of the Crimsons, and Cullingfordi will soon be in prime condition.—L. CASTLE.

## THE HULL CHALLENGE CUP.

CONSIDERABLE interest in the past has been attracted to those societies which have ventured out of the beaten path and offered large trophies for Chrysanthemums to be the property of those who succeed in winning them two years in succession. Whatever may be urged in their favour or whatever popularity they bring to a society, cups offered on these principles are not now regarded with much favour amongst growers of the plants and blooms.

The first of these cups was offered at Kingston-on-Thames, and finally resulted in the southern and northern growers trying their relative strength. The interest in this struggle was of the keenest description. It will be remembered that Mr. Harding ultimately succeeded in securing the cup, and I think north and south alike endorsed the verdict without calling into question the fair and unbiassed decision of the judges. At the same time, from what I can gather from southerners and northerners, it is conceded that Mr. Tunnington staged the greatest number of good flowers if the number of points had been counted throughout the contest, hence by this test the cup would have fallen to him. It is, however, no part of my duty to act the part of judge in this matter, but one fact has been brought prominently to the front—namely, that more credit is due to Mr. Tunnington than to any other man for stimulating the high culture of this autumn flower, especially the incurved, while he can justifiably claim the same honour in regard to Japanese in the neighbourhood of Liverpool.

During the last two years Hull has been unmistakeably the centre of attraction, especially in the northern parts of the country, for the contest for the challenge cup has been waged between two noted Liverpool growers. I am aware the competition was not confined to these gardeners, but the struggle for the coveted prize naturally seemed to lie between the two, for both up to the present have been successful. This year might have decided the conflict if Mr. Mease had been successful; if Mr. Lindsay had secured the custodianship of the cup another contest at least would have been inevitable. If all went well no doubt both exhibitors would have come out in their finest form, and the struggle would unquestionably be close. But circumstances have occurred that have altered this state of things. Nobody now, at least in one great Chrysanthemum centre, seems particularly interested in the coming contest, for it has become known that Mr. Mease is not to take part in the competition for the coveted vase. It is contended, so I understand, that to allow him to do so would be illegal, as his employers, Mr. and Mrs. Neumann, have both died since he won the cup last November. At this time last year speculations as to the probable winner were fully discussed, but the matter this year is scarcely mentioned, and no wonder when one of the principal competitors has been debarred.

I think when decisions of such a nature are arrived at they should be made known, for they are of great public interest. What are the grounds upon which such a decision has been arrived at? This is a natural question to ask. Is any precedent known to the Committee of the Hull Chrysanthemum Society to warrant them in coming to the conclusion they have done, or has it been decided on legal grounds? Under any circumstances it is important that intending exhibitors, as well as those interested, should know the grounds upon which Mr. Mease has been ruled out of the list of eligible competitors. A clear statement of the facts should be made public, for they might prevent considerable trouble and annoyance in the future, and, perhaps, legal proceedings, which it is always wise to avoid if possible, and often might be avoided if the reasons for such actions were placed before the public instead of being kept a secret.

When the circumstances of the case are taken into consideration I fail to see any justifiable reason for excluding an exhibitor. If Mr. and Mrs. Neuman had left no representatives then I could have understood the contest being rendered void. But in this case the plants were kept for the purpose of carrying to a conclusion, either successfully or otherwise, engagements that had been entered into by Mr. Mease during the lifetime and with the sanction of his employer. After the decease of Mr. and Mrs. Neumann, who were legally entitled to the care of the cup until it had to be returned to the Committee of the Society, I venture to assert that the executors were the gentlemen to do it, and to them the Committee would have to look for its being returned, and who but these gentlemen would have had to replace it in case of damage or destruction?

I have said that trophies offered on the conditions that they have to be won two years in succession are not highly favoured by growers, and I feel convinced that they will attract less attention in the future than in the past; for many circumstances might prevent exhibitors taking part a second and third year, and if they are liable to be dropped out of the contest for reasons that are not very clear, or that are never laid before the public, attention will be concentrated towards prizes offered to be won in one year.

This matter is not brought forward from any selfish or personal motives, but to ascertain, by discussion of the subject or otherwise, the basis upon which such decisions are formulated.—A CHRYSANTHEMUM GROWER.

[Our correspondent is not a disappointed exhibitor.]

## CHRYSANTHEMUM SHOWS.

THE following are the dates of the principal shows to be held



during the coming month, at which Chrysanthemums will be the leading feature:—The figures following the names of the place at which the shows are to be held indicate the number of days devoted to the exhibitions, and it will be seen that a large majority are two-day shows.

NOVEMBER.

Tuesday, 1st ... Southampton (2)	Tuesday, 15th ... Southgate (2)
Thursday, 3rd ... Havant (2)	Lincoln (2)
Friday, 4th ... Henfield (2)	Watford (2)
Monday, 7th ... Surrey (2)	Finchley
Tuesday, 8th ... Royal Horticultural Society	Winchester (2)
Brighton (2)	Putney
St. Neots	York (3)
Lambeth (3)	Birmingham (2)
Highgate (2)	Faversham (2)
Southend (2)	Northampton (2)
Kingston (2)	Ealing
Wednesday, 9. h	Dartford (2)
Bath (2)	Chelmsford
Croydon	Bury St. Edmunds (2)
National Soc. (2)	Chiswick
Ascot (2)	Hull (2)
Cornwall (2)	Barnsley (2)
Portsmouth (2)	Taunton
Brixton (2)	Colchester
Walton	Wimbledon
Ipswich (2)	Bolton (2)
Weald of Kent (2)	Friday, 18th ... Sheffield & West Riding (2)
Dawlish	Reading
Hitchin	Chorley (2)
Canterbury (2)	Saturday, 19th... Ramsbottom
Huddersfield (2)	Monday, 21st ... Wolverhampton (2)
Street (2)	Tuesday, 22nd ... Liverpool (2)
Lewisham (2)	Wednesday, 23rd Bedford (2)
Monday, 14th ... Sheffield & Hampshire (2)	Friday, 25th ... Eccles (2)

DECEMBER.

Thursday, 8th, Alnwick.

THE INSECT ENEMIES OF OUR GARDEN CROPS.

THE GRAPE.

(Continued from page 143.)

SOME people have an idea that we are troubled with more insect pests about our gardens and houses than were those who lived, say, a century ago or more, but such is not the case; it is rather likely we have less, only we read and hear a good deal concerning them owing to the free communication of facts in the present day. The enormous imports of foreign plants have not made such difference, for out of many species of insects that occasionally accompany these it is certain that few have established themselves in Britain. Now, with regard to the Vine, there is a perceptible improvement. Take the instance of the annoying and prolific scale insect; scarcely a house would be found now in the condition that slow-going folks sometimes allowed them to be formerly, when the insects spread from the Vines to the woodwork, and the simple but severe remedy was the destruction of both. I am inclined to think the Phylloxera, which is allowed to be a comparative novelty, has, though of so evil a repute, done less harm here than the older foes of the same tribe of insects, the scale, the bug, and the doubtfully placed thrips. From aphids, so often a scourge to fruit-bearing trees, the Vine is remarkably free, especially if under glass, but this may now and then be discovered at the tips of the shoots or clustering on young leaves. Not, apparently, a species peculiar to the Vine, it is one or other of those which are erratic in their habits; frequently it is the aphid of the Cherry or the Peach, and is easily dealt with.

The names of blight and bug have been freely applied to two of the insects of the Hemipterous order, which contains so many notable enemies of the Grape crop; but without going into the science of the matter, there is at once the distinction that one is a mealy creature and the other throws forth a profusion of woolly substance. This is usually and aptly called the Vine scale, from the singular shield into which the body of the female is transformed; it is also the more troublesome pest, owing to its persistency in diffusing itself, and the difficulty in effecting its extermination. *Coccus vitis* occurs upon Vines in and out of houses, and if the scale-like body of the female has been left intact during the winter the wool which enwraps the eggs, loosened by the winds of spring, is a medium for the conveyance of part of the brood to new localities, and though the estimate that each female lays from 800 to 1000 eggs may be in excess, the number is certainly large, for the young larvae are very small, yet they soon produce marked results by their suction of the sap. They are slender, six-footed, and at

first brownish white, afterwards they darken to a deep brown, the females retaining the larval appearance, but becoming more rounded, and as they cling closer to the stem, and the shield or scale develops, the legs are absorbed into the body. The males emerge as flies during the summer, with the usual opaque wings of a coccus, and two filaments at the tail, scarlet in colour, yet being diminutive they appear to be seldom observed. Possibly they are fewer in number than their female companions.

Owing to the double protection the young brood get from the parent's shield, and the woolly matter secreted, fumigation is not to be relied upon, nor syringing or wetting, which only moistens the insect without actually removing it from the rods and branches. Besmearing the Vines with clayey or sticky compounds in which are contained tar or other insect killers is not a practice to be advised. Applications made from Gishurst compound or nicotine soap are useful, and the wash of softsoap and petroleum, often recommended as a dressing for various fruit trees, which may safely be applied even to the young shoots of Vines, say at a temperature of 120°; or softsoap liquor alone will often avail with diligent rubbing, and this may be some degrees hotter; it is safe to 160° for the resting rods I am told. One article that is specially poisonous to this scale is nux vomica, the powder being added to hot water, but this is expensive and dangerous.

The mealy bug or *Coccus adonidum* is no doubt a naturalised foreigner, though no one can say when and from whence it arrived in our island. With us it is confined to houses, but in warmer climates the species thrives out of doors and attacks a great variety of softwooded plants. This has no coat of scale, but it throws out a whitish meal, reminding us of the American blight of the Apple, on removing which we see the scarlet body of the bug. As in the preceding species, the male is slender and winged. The female resembles the house bug, though it is larger, and if not so prolific as the scale insect it breeds more frequently, the spring brood being succeeded by others, which pass rapidly through their changes in the warmth of the houses unless they are interfered with. Tobacco does not have that effect on mealy bug that it has upon the aphides or thrips; sulphur is fatal to them, but then ruinous to Vines, but there is no reason why this pest should be suffered to increase so as to render a sulphur fumigation requisite. A sulphur wash, prepared from sulphur vivum (or black sulphur), with a little quicklime added to the water in which the sulphur is boiled, while well stirred for three-quarters of an hour, answers as a winter dressing for Vines and other trees infested. The proportion is half a pound of sulphur to each gallon, the liquid being cooled and poured off the dregs; but plain water cold, even, and still more effectually at 120° applied forcibly and persistently clears off this insect by dislodging it or removing its mealy coating. Some persons put much faith in spirits or oils used diligently with a soft brush; these certainly kill the insect, if not always the eggs, but the oils, such as rape oil and turpentine, may have, under some circumstances, a hurtful influence upon the Vine. There is less objection to the employment of proof spirits of wine or whisky, and these are much favoured across the Atlantic, where the mealy bug is too well known. There are occasional instances where the mussel scale of the Apple, *Aspidiotus conchiformis*, shows itself upon Vines out of doors; in this case the attack is sometimes thought of no moment from the minuteness of the foe, but it is desirable to remove it by a soap wash or other dressing during the spring, as the young brood creep from under the parent's shells in April and May.

The dry summer of 1887 was favourable to the species of thrips, and the Vine did not escape their active hosts, which are best dealt with, if observed, while in their larval condition and only able to crawl. There are several broods in succession, and if the first of these is allowed to develop the greater part of the thrips in their winged state it is sure to be troublesome the rest of the season. While the Vines are fruiting it is impossible to adopt strong measures in houses, and the only plan is to sponge the leaves carefully with tobacco water or softsoap liquor. Early in the year there is no better remedy for thrips than tobacco fumigation, but when the leaves have expanded and it suddenly appears it may, like the red spider, require sulphur treatment.—J. R. S. C.

THE STRUCTURE OF FLOWERS WITH REFERENCE TO INSECT AID IN THEIR FERTILISATION.

PROTERANDROUS plants, or those in which the anthers mature before the stigmas, are much more numerous. As examples amongst the wild flowers which are to be found in this locality (Bath) I must mention Wild Thyme (*Thymus scryphillum*), Rose Bay, Willow Herb (*Epilobium angustifolium*), Blue Meadow Crane's Bill (*Geranium pratense*), Mountain Crane's Bill (*G. pyrenaicum*), with many of the Umbelliferae and most of the Compositae. Sir John Lubbock states that most of the British wild flowers which contain both stamens and pistils are more or less proterandrous. These are almost dependent upon the visits of insects

for fertilisation. Amongst foreign plants now common in conservatories, *Clerodendron Thompsoni*, a verbenaceous African climber, is a good example of a proterandrous plant. Its crimson corolla and bright white calyx in combination are very conspicuous and serve to attract insects. The long filiform filaments and style, upwardly euerled in the bud, straighten and project when the corolla opens, the stamens remain straight, but the style proceeds to curve downward and backward on the second day, the anthers are effete, and the filaments recurved and rolled up spirally; while the style has taken the place of the filaments, and the two stigmas, now separated and receptive, are in the very position occupied by the anthers the previous day. The entrance by which the proboscis of a butterfly may reach the nectar at the bottom is at the upper side of the orifice. It is impossible for the flower to self-fertilise. A good sized insect flying from flower to flower, and plant to plant, must carry pollen from one to the stigma of the other.

I cannot help calling attention to the mode in which cross-fertilisation is secured in the Blue Meadow Crane's Bill (*Geranium pratense*) for several reasons. This beautiful Crane's Bill, with its lovely blue corolla and elegant leaves, must be well-known to all who stroll in the meadows adjoining the Avon or by the brooks in the neighbourhood of this fair city. It is especially interesting as the flower which first led Sprengel to his researches. "In the year 1787," writes Sir John Lubbock, "he (Sprengel) observed that in the corolla of this species there are a number of delicate hairs, and convinced, as he says, 'that the wise Author of Nature would not have created a single hair in vain,' he endeavoured to ascertain the use of these hairs and satisfied himself that they served to protect the honey from rain." Another point of interest in this flower is the spontaneous movement of the stamens and pistils. Kolreuter seems to have been the first to observe this motion in another dichogamous plant, *Ruta graveolens*. He supposed that the object was to bring the stamen in contact with the pistil and so insure close fertilisation. Nature, as Sprengel pointed out, had a very different purpose to fulfil. It was to bring the stamen and pistil successively in contact with the same part of the insect's body, and so insure cross-fertilisation. When the flower first opens, the stamens lie on the petals, at right angles with the upright pistils. As they come to maturity they raise themselves parallel, and close to the pistil, which is, however, not yet capable of fertilisation. After they have shed their pollen they return to their original position and the stigmas unfurl themselves. As the stigmas do not become mature until all the stamens have shed their pollen, *G. pratense* is wholly dependent upon insect aid for fertilisation. The spontaneous movement thus insures cross-fertilisation, and indicates another of Nature's plans for bringing about the end desired by making certain insects the carriers of the pollen.

I will now direct attention to another very successful arrangement for promoting cross-fertilisation through the agency of insects. Probably many have noticed the Primroses (*Primula vulgaris*) present different appearances with regard to the stamens and pistils. In some the pistil is found at the top of the tube, and the stamens half way down; in others the stamens are at the top of the tube, and the pistil half way down. Corresponding differences may be seen in the Cowslip (*P. veris*), *Polyanthus*, and *Auricula*. This difference in the form of the flowers has long been known by the homely names of "thrum-eyed and pin-eyed." Plants which present these differences of form are known as heteromorphous; those which have two forms of flower, like the Primrose, as dimorphous; and those which have three forms, as in *Lythrum salicaria* (Purple Loosestrife), as trimorphous. Sprengel, as Darwin mentions, had noticed this difference in form in *Hottonia* before 1793. "Sprengel," writes Darwin, "with his usual sagacity, adds that he does not believe the existence of the two forms to be accidental, though we cannot explain their purpose." Trimorphism was noticed by Vaucher in 1841, and by Wirtgen in 1848. It was left to our great naturalist, Charles Darwin, to interpret, in the *Journal of the Linnean Society*, 1862, this curious phenomenon.

Referring to dimorphism in the case of the Primrose, Sir John Lubbock observes, "An insect thrusting its proboscis down a Primrose of the long-styled form, would dust its proboscis at a part which, when it visited a short-styled flower would come just opposite the head of the pistil, and could not fail to deposit some of the pollen on the stigma. Conversely, an insect visiting a short-styled plant would dust its proboscis at a part further from the top; which when the insect consequently visited a long-styled flower would again just come opposite the head of the pistil. Hence we see by this beautiful arrangement insects must carry the pollen of the long-styled form to the short-styled, and *vice versa*." Mr. Darwin has shown that much more seed is set if pollen from the one form be placed on the pistil of the other, than if the flower be fertilised by pollen of the same form, even taken from a different plant.

This eminent naturalist, in his interesting work on the forms of flowers, after giving a minute and graphic description of trimorphism in the case of *Lythrum salicaria* (Purple Loosestrife), observes, "In a state of Nature the flowers are incessantly visited for their nectar by hive or other bees, various Diptera, and Lepidoptera. The nectar is secreted all round the base of the ovary; but a passage is formed along the upper and inner side of the flower by the lateral deflection of the basal portion of the filaments; so that insects invariably alight on the projecting stamens and pistils, and insert the proboscis along the upper and inner margin of the corolla. We can now see why the ends of the stamens with their anthers, and the end of the pistil with the stigma, are a little upturned; so that they may be brushed by the lower hairy surfaces of the insects' bodies. The shortest

stamens, which lie enclosed within the calyx of the long and mid-styled forms, can be touched only by the proboscis and narrow chin of a bee; hence they have their ends more upturned, and they are graduated in length, so as to fall into a narrow file, sure to be raked by the thin, intruding proboscis. The anthers of the longer stamens stand laterally further apart, and are more nearly on the same level, for they have to brush against the whole length of the insect's body.

"I have found no exception to the rule that when the stamens and pistil are bent, they bend on that side of the flower which secretes nectar. . . . When nectar is secreted on all sides, they bend to that side where the structure of the flower allows the easiest access to it, as in *Lythrum*. . . . In each of the three forms, two sets of stamens correspond in length with the pistil in the other two forms. When bees suck the flowers, the anthers of the longest stamens, bearing the green pollen, are rubbed against the abdomen and inner sides of the hind legs, as is likewise the stigma of the long-styled form. The anthers of the mid-length stamens, and the stigma of the mid-styled form, are rubbed against the under side of the thorax and between the front pair of legs. And lastly, the anthers of the shortest stamens, and the stigma of the short-styled form, are rubbed against the proboscis and chin; for the bees in sucking the flowers insert only the front part of their heads into the flower. On catching bees, I observed much green pollen on the inner side of the hind legs, and on the abdomen, and much yellow pollen on the under side of the thorax. There was also pollen on the chin, and, it may be presumed, on the proboscis; but this was difficult to observe. I had, however, independent proof that pollen is carried on the proboscis; for a small branch of a protected short-styled plant (which produced spontaneously only two capsules) was accidentally left during several days pressing against the net, and bees were seen inserting their proboscis through the meshes, and, in consequence, numerous capsules were formed on this one small branch. . . . It must not, however, be supposed that the bees do not get more or less dust all over with the several kinds of pollen; for this could be seen to occur with the green pollen from the longest stamens. . . . Hence insects, and chiefly bees, act both as general carriers of pollen, and as special carriers of the right sort."

A long series of experiments proved that both kinds of pollen are nearly or quite impotent upon the stigma of the same flower, and that no ovary is fully fertilisable in any other manner than by stamens of the corresponding length. *Nesaea verticillata*, a common *Lythraceous* plant of the Atlantic United States, is, according to Dr. Asa Gray, similarly trimorphous. Several South African and American species of *Oxalis* are trimorphous, and have been investigated by Darwin and Hildebrand, with the same result as in *Lythrum salicaria*. Referring to trimorphism, Mr. Darwin observes in one of his valuable works, as follows:—"Fritz Müller has seen in Brazil a large field, many acres in extent, covered with the red blossoms of one form (of an *Oxalis*) alone, and these did not produce a single seed. His own land is covered with the short-styled form of another species, and this is equally sterile; but when the three forms were planted near together in his garden they seeded freely." "All known flowers," writes Dr. Asa Gray, "exhibiting reciprocal dimorphism, or trimorphism, are entomophilous" (insect fertilisable). No such wind-fertilisable species is known. Few of them are irregular, and none very irregular; they do not occur, for instance, in *Leguminosæ*, *Labiatae*, *Scrophulariaceæ*, *Orchidaceæ*, &c. Nature is not prodigal, and does not endow with needless adaptations flowers which are otherwise provided for.—W. G. WHEATCROFT (in *Journal of Microscopy*).

(To be continued.)

## ROYAL HORTICULTURAL SOCIETY.

OCTOBER 25TH.

A REMARKABLE display of vegetables was provided in the conservatory at South Kensington on Tuesday last, when the numerous prizes offered by the leading firms of seedsmen induced a large attendance of exhibitors. Very seldom is such an extensive show seen in London, as, besides the collections, considerable space was occupied with Potatoes, Onions, Celery, and Carrots, the majority of fine quality. In addition to these there were the usual exhibits before the Floral and Fruit Committees, Messrs. Hooper and Co.'s Carnations and Mr. R. Gilbert's Burghley novelties being the chief features in each case. The side tables were fully occupied, and a broad central table, extending the whole length of the conservatory, was filled with the vegetables, the western half being devoted to Messrs. Sutton's classes, and the opposite end to Messrs. Carters', Webb's, and Wood's classes.

FRUIT COMMITTEE.—Present—H. J. Veitch, Esq., in the chair, and Messrs. T. J. Saltmarsh, T. B. Haywood, A. H. Pearson, Harrison Weir, Arthur W. Sutton, C. Ross, Wm. Denning, W. Warren, R. D. Blackmore, J. Burnett, P. Barr, Sidney Ford, and John Woodbridge. Messrs. J. Veitch and Sons, Chelsea, exhibited handsome fruits of Bismarck, Sandringham, and Baumann's Reinecke Apples, the latter highly coloured. Mr. C. Ross, Welford Park Gardens, Newbury, was awarded a cultural commendation for three exceedingly fine Smooth Cayenne Pine Apples, weighing 8½ lbs., 8 lbs., and 6 lbs. 13 ozs., very deep finely proportioned fruits of a rich colour. Mr. T. Laxton, Bedford, sent fruit of his seedling Pear, Laxton's Bergamot, but it was over-ripe. Mr. J. Bond, Coventry, sent fruits of Adam Bede Apple. Messrs. James Backhouse & Sons, The Nurseries, York, showed samples of Backhouse's Beurre Pear. Mr. Hough, Harrow Hill, showed fruits of an Apple named Harrovian, which was passed. Mr. H. Wingrove, Rousham Park Gardens, Steeple Aston, Oxon, sent fruits of a pretty little yellow Apple, said to be a seedling from Blenheim Pippin. Messrs. W. Johnson & Son, Boston, Lincolnshire, exhibited fruits of Apple Manchester Beauty, of a bright red colour, and fair flavour. Mr. S. Ford, The Gardens, Leonardslee,



Horsham, exhibited fruits of a seedling Apple somewhat like a large form of the last named, and coloured similarly.

Mr. W. Divers, Wierton Gardens, Maidstone, was awarded a cultural commendation for fine fruits of Seckle Pears, and seedling Apples were sent by several other exhibitors, amongst them being one named Lord Cottenham, from Dr. Walker, 12, Lingfield Road, Wimbledon, very neat in shape, somewhat conical, yellow, with red streaks on one side. It is a heavy Apple, and of good appearance. Mr. John Crooke, Farnborough Grange Gardens, Hampstead, sent several dishes of Plums, Coe's Golden Drop, Reine Claude de Bavay, and Blue Imperatrice. A dish of fine fruits of Pears Doyenné du Comice from a tree on a wall, and fine fruits of Beurré Superfin were also shown. Mr. D. Murray, Culzean Castle Gardens, Maybole, Ayrshire, exhibited a fine sample of Green Curled Kale. Mr. R. Dean, Ealing, sent tubers of Potato Prime Minister, grown since September 1st, large and even; a good Moss-curl Parsley also came from the same exhibitor. Mr. J. Lye, The Gardens, Clyffe Hall, Market Lavington, exhibited tubers of a seedling Potato, a cross between Purple King and Woodstock Kidney. The tubers were large, somewhat flat, but even, and with few eyes. The haulm is said to be stout, about 20 to 24 inches high, and this is the third year's trial.

Mr. R. Gilbert, Burghley Gardens, Stamford, exhibited a collection of his vegetable novelties, comprising Chou de Universal with sprouts of immense size; Jubilee Green Sprouts, also large and solid; Universal Savoy, a small compact-hearted variety; and the celebrated Chou de Burghley, for which a vote of thanks was awarded. Mr. Gilbert's exhibit was very interesting, and attracted much attention. A cultural commendation was awarded to Mr. G. Bloxham, The Gardens, Brickhill Manor, Bletchley, Oxon, for six specimens of Veitch's Superb White Cos Lettuce, very solid and good. Mr. Fletcher, Annesley, Notts, showed a new Potato named Lord Tennyson, very large flat tubers with purple eyes. Mr. Burden, The Gardens, Wakegreen House, Moseley, Birmingham, also sent a new Potato named Vicar of Moseley, said to be the result of a cross between Vicar of Laleham and Woodstock Kidney; it resembled the former.

FLORAL COMMITTEE.—Present: G. F. Wilson, Esq., in the chair, and Messrs. J. Douglas, W. Wilks, J. Fraser, H. Herbst, W. H. Lowe, R. Dean, W. Holmes, C. Noble, C. Pilcher, H. Ballantine, H. M. Pollett, J. O'Brien, A. J. Lendy, G. Duffield, Shirley Hibberd, James Hudson.

Messrs. Hooper & Co., Covent Garden, exhibited a large group of Carnations in pots, comprising 120 well grown plants in three dozen varieties. Some of the most notable were F. V. Raspail, scarlet in its early stage, becoming rather lighter when more advanced; J. P. Nugue, rich scarlet, very dwarf and early, strong and free; Irma, bright rose; Sultan, white streaked rose; Dr. Raymond, deep maroon, like a Clove; Jean Naturelle, very free, salmon flaked bright rose, fine blooms, keeps its colour well; Mlle. Carle, pure white, excellent; Vesuvius, a strong growing variety, very free, bright scarlet, capital for cutting; Louise Chrétien, pure white ground, with few bright rose streaks; Madame Bordet, large white, few pale rose streaks, handsome; Souvenir de la Bruyère, scarlet, exceedingly floriferous, good habit; Zuave, red streaked dark scarlet, good habit; Charles Lombard, crimson rose, bright, light centre, handsome, compact in habit; Lonis Bernhard, fringed, purplish crimson shaded, distinct; Madame Massicault, yellowish centre, edged purplish lilac; Chateaubriand, very large, rose coloured, dwarf, best in spring; George Paul, salmon centre, shaded pale pink, pretty; Henriette Nugue, white streaked rose, large flower, dwarf and free. A silver Banksian medal was awarded for this handsome group. Mr. W. Holmes, Frampton Park, Hackney, showed thirty-six Japanese Chrysanthemum blooms of new varieties, comprising several of considerable merit. A special vote of thanks was awarded for Macaulay, a peculiar bronze yellow with much curled and crisped florets, deeply and irregularly cut at the points. This would have been certificated, but only two blooms were shown, and three are required by the Committee's rules. One named Forester was much like Belle Paule. Samuel Morley, brilliant red, gold reverse, medium size; M. Canet, dull red, a curious colour; Wm. Cobbett, certificated last meeting; C. Wagstaff, pure white, broad florets; Othello, bronze yellow, edged red; and Macbeth, bright yellow.

A vote of thanks was awarded to W. Cobb, Esq., Sydenham, for a plant of *Vanda Sanderiana* with a raceme of nine large flowers. Mr. Cowley, gardener to F. G. Tauts, Esq., Studley House, Hammersmith, was awarded a vote of thanks for *Cattleya Loddigesii* candida with one pearly white flower, a *Cypripedium* named *obscurum* in the style of *C. insignis*, and *Cirrhoptalum ornati-ssimum* with four flowers, the lateral sepals bearing a curious tuft of purplish hairs. Messrs. J. Veitch & Sons, Chelsea, exhibited plants of the following:—*Begonia John Heal*, the beautiful hybrid between *B. socotrana*, and a *Tuberona* variety. It is very free flowering, bright rose in colour, lasting for a great length of time, all the flowers being staminate. *Amaryllis solandriiflora*, a New Grenadan species with very long tubular flowers (10 inches long) greenish white. *Begonia Adonis*, a cross between one of the tuberous varieties and *John Heal*, the latter being the pollen parent. In habit it resembles the tuberous section, with large but rounded leaves and large rosy scarlet well-formed flowers. A box of brilliant hybrid *Rhododendron* flowers was also shown, and a fine new scarlet *Bouvardia*.

#### CERTIFICATED PLANTS.

*Chrysanthemum Mrs. J. Wright* (G. Stevens, Putney).—A Japanese variety raised by Messrs. J. Laing & Co., and shown and certificated at the Crystal Palace in 1886, but the blooms were not nearly so fine as those at Kensington, which were 7 inches in diameter, deep, with substantial recurving florets of a pearly white tint. Exceedingly handsome, one of the best new varieties shown this year.

*Chrysanthemum Marie Ouvray* (W. Holmes).—A new Japanese variety of the present year with spreading florets, rosy crimson, white reverse. Full and rich colour.

*Bouvardia President Cleveland* (J. Veitch & Son).—An excellent novelty, remarkable for its brilliant scarlet flowers, the lobes of the corolla large, and the clusters dense. The plant is of good habit and a fine addition to the *Bouvardias*.

#### SPECIAL PRIZES FOR VEGETABLES.

Twenty-one classes were appropriated to Vegetables, in all of which the

prizes were offered by seedsmen, and some idea of the competition can be formed from the fact that in the leading classes the number of entries ranged from ten to twenty-four.

Messrs. Sutton & Sons, Reading, contributed prizes for six dishes of Potatoes, which brought seventeen exhibitors. Mr. Hughes, Eydon Hall Gardens, was first with excellent samples of Forty-four, Prizetaker, Twenty-one, Reading Russet, Favourite, and Reading Ruby. Mr. E. S. Wiles was a close second, showing fine dishes of Twenty-one, Abundance, Reading Ruby, Sutton's Seedling, Favourite, and Reading Russet; Mr. W. H. Smith, Harpit Wanborough, Shrivensham, was third. Mr. G. Allen, gardener to Sir J. Burdett, Bart., Rainsbury Manor, Hungerford, fourth; and Mr. E. Chopping, Milton, fifth.

There was also a good competition with five dishes of Potatoes, sixteen collections being staged. Mr. Hughes won first honours with Twenty-one, Forty-four, Sutton's Seedling, Abundance, and Thirty-six, fine even tubers. Mr. E. Chopping was a close second; Mr. E. S. Wiles third; Mr. C. W. Howard, Bridge, Canterbury, fourth; and Mr. C. Ross fifth.

In the class for four varieties of Onions there were seven competitors, and Mr. E. S. Wiles won the first prize with Abundance, Silver Globe, Crimson Globe, and Golden Globe; followed by Messrs. Hughes, T. A. Beckett, and R. Lye. For twelve Onions of one variety, Mr. E. S. Wiles was first amongst fifteen exhibitors, with Improved Reading. Messrs. Hughes and J. Baker following.

Three prizes were offered for three sticks of White Gem Celery, which brought twelve exhibitors, the first prize specimens from Mr. R. Lye being fine solid heads; Mr. J. Bunting, Enfield, and Mr. R. Timms, Amersham, being second and third. With six roots of Dark Red Beet there were nineteen competitors, Mr. J. Neighbour, Chislehurst, taking the lead, with Messrs. C. J. Waite and R. Lye as winners of the second and third prizes. The largest class of all was that for six specimens of New Intermediate Carrot, twenty-four entering in this, staging clean handsome samples of this fine selection. Messrs. Neighbour, Pope, Lye, Waite, and G. H. Richards were the prizetakers in the order named. Fifteen exhibitors of six Prizetaker Leeks competed for the three prizes, which were secured by Messrs. J. Spottiswood, J. Mair, and E. Chopping. Of the fourteen lots of Student Parsnip Mr. Lye had the best examples, followed by Messrs. Waite and Richards. The prizes in all these classes were offered by Messrs. Sutton and Sons, who in addition had a fine exhibit of Potatoes, occupying considerable space at one side of the conservatory. The principal varieties shown were seedlings raised by the firm, some of which are named and others still under numbers. First and Best, Woodstock Kidney, Prizetaker, Abundance, Sutton's Seedling, and Reading Hero were very noticeable. A silver Banksian medal was awarded for the collection.

Messrs. J. Carter & Co., High Holborn, offered prizes for a collection of vegetables, which brought ten exhibitors. Mr. W. Pope, Highclere Gardens, Newbury, won first honours with handsome samples of Lyon Leek, Dark Red Beet, Ashtop Fluke, Village Blacksmith, and Chancellor Potatoes, Autumn Giant Cauliflowers, Maincrop Onions, New Intermediate Carrots, Little Pixie Cabbages, Green Top Six Weeks Turnips, Holow Crown Parsnip, and Standard Bearer Celery. Mr. R. Lye, Sydmonton Court Gardens, was a good second with very even fine specimens Autumn Giant Cauliflowers, Lyon Leeks, and Early Six Weeks Turnips being notable. Mr. S. Haines, Cobesbill House Gardens, Highworth, was third, and Mr. C. J. Waite, Glenhurst Gardens, fourth.

Messrs. W. Wood & Son, Wood Green, offered a silver cup and other prizes for four dishes of Potatoes; there were twenty-four exhibitors, and all were very close in merit. Mr. J. Hughes, Eydon Hall Gardens, Byfield, was first with London Hero, Vicar of Laleham, Mr. Bresee, and Chancellor, all very good. The second and third exhibitors, Mr. Ellington and Mr. E. S. Wiles, showed tubers so near in quality that a medal was awarded to each. Amongst other exhibitors, Mr. Chopping had a wonderfully fine dish of Sutton's Thirty-six.

Messrs. Webb & Sons, Wordsley, Stourbridge, offered prizes for six dishes of Potatoes, which were won by Messrs. Ross, E. S. Wiles, and W. Pope, in the order named. The first prize collection comprised Red King, Renown, Improved Schoolmaster, Surprise, Discovery, and Kinver Hill, all Messrs. Webb's varieties. Messrs. Webb & Sons also contributed a large collection of Potatoes, for which a bronze Banksian medal was awarded. Some of the most notable varieties were Emperor, Wordsley Pride, M.P., The Dean, Improved Schoolmaster, Stourbridge Beauty, Prime Minister, Rector of Woodstock, Benefactor, Prizetaker, and Renown.

Mr. H. Deverill, Banbury, offered prizes for varieties of Onions, such as Rousham Park Hero, Anglo White Spanish, Improved Wroxton, and Maincrop, also for Aylesbury Prize Red Celery and the Wroxton Brussels Sprouts. These brought a large number of exhibitors, the principal prizes being awarded to Messrs. Wiles, Neal, Wingrove, D. Murray, F. Doherty, S. Haines, and C. J. Waite. Mr. H. Deverill also had an extensive exhibit of Celery, Carrots, Beet, Onions, and Brussels Sprouts of his special varieties. A silver Banksian medal was awarded for this collection.

In the classes provided by Mr. C. Fidler, Reading, there was good competition, Mr. Hughes taking the lead with six dishes of Potatoes, Chancellor, Pink Perfection, Fidler's Perfection, Prolifio, London Hero, and General Gordon. Mr. Hughes was also first in the class for three dishes. Mr. Wiles was first with nine dishes, comprising Clipper, Reading Russet, Snow Queen, M.P., Reading Giant, Crimson Beauty, Chancellor, Vicar of Laleham, and London Hero. Other exhibitors and prizewinners were Messrs. G. Allen, E. Chopping, and J. Lye. Mr. C. Fidler had a large collection of Potatoes not in competition, representing a great number of varieties, and a silver Banksian medal was awarded for them.

Mr. T. Laxton, Bedford, had a collection of new seedling Potatoes with fruits of his open air Tomatoes, of excellent colour, and samples of Sandy Prize Onions. Mr. J. House, Peterborough, sent thirty-nine varieties of Potatoes, for which a vote of thanks was accorded, a number of the best varieties being represented by good tubers. A collection of Potatoes was shown from the Society's garden at Chiswick, comprising a number of seedling varieties that have been tried there this season. A large collection of Turnips was also shown from Chiswick, representing numerous varieties,



## NATIONAL CHRYSANTHEMUM SOCIETY.

FLORAL COMMITTEE.—OCTOBER 26TH.

PRESENT.—E. Sanderson, Esq. (in the chair), and Messrs. C. Gibson, Lewis Castle, H. Cannell, George Gordon, Charles Swift, T. Bevan, G. Stevens, R. Owen, J. Mardlin, J. P. Kendall, R. Dean, and W. Holmes.

The third meeting of this Committee in the present season was held, as before, in St. Stephen's Hall, Westminster, and there was a much larger number of exhibits than at the preceding meeting. The majority of the blooms shown were new varieties of this year, but most of them had to be passed without comment as too small, insufficiently advanced, or not distinct enough from others already in cultivation. Some discussion occurred respecting the variety *Elsie*, which has been hitherto regarded as a reflexed flower, but some were shown at this meeting of both reflexed and Japanese types. Ultimately a certificate was awarded for the reflexed flower, which we understand was from undisbudded plants, the larger and coarser blooms coming from plants grown in the large exhibition bloom style. It is evidently unsuited for this mode of culture. Mr. Stevens obtained another certificate for the pearly white Japanese Mrs. J. Wright, the blooms being from crown buds, and it should be observed that a bloom from a terminal bud shown by Messrs. Davis and Jones was larger, later, and did not show the same character, being thinner and more spreading.

Mr. Stevens, Putney, was awarded a silver medal for twelve new varieties, comprising *Le Reveil*, a quilled bronze (Delaux); *Cream Seedling* (Stevens) flat florets; *Feu de Bengale* (Delaux), bronze red; *Theodore Bullier* (Delaux) crimson recurving florets; *Middle Temple* (Delaux), spreading rosy floret; *Lord Tenynson* (Delaux), yellow centre, bluish outer, spreading; *Duke of Berwick* (Delaux), thread florets, drooping, ivory white, with a faint rose tint in centre (first-class certificate); *Ralph Brocklebank* (Winkworth); *Samuel Morley* (Delaux) crimson reflexed; *Ormond* (Delaux), yellow long florets; *Elsie* (Cannell), creamy white reflexed; *Elie Rumble* (Delaux), rosy lilac, a small Japanese.

A bronze medal was awarded to Messrs. Davis & Jones for fine blooms of *C. Wagstaff*, white; *M. Molle*, bronzy red; *Mina*, thread recurving florets, white tinted rose; and *Miss Gorton*, cream white, large. The others were smaller, but *Romeo*, *Duke of Berwick*, *Anna Roudiere*, *Guy Fawkes* (a large incurved), and *Bickley Park*, recurving florets, rosy crimson, were pretty. Mr. R. Owen, Maidenhead, sent a stand of new flowers, comprising *Amy Furze*, the semi-double *Buttercup*, bright yellow, and *Elsie*, reflexed creamy yellow (certificated). Mr. W. Holmes, Hackney, had a stand of new varieties similar to those at Kensington yesterday. A first-class certificate was awarded for *Macaulay*, the peculiar crisped curled bronze yellow variety already noted.

Messrs. J. Carter & Co, High Holborn, showed a new Japanese variety named *Lady Lewisham*, white, tinted crimson, recurving florets, but too small. A reflexed seedling named *James Carter* was commended for its colour, a rich golden bronze, but it was not considered large enough for an exhibition bloom.

Mr. T. S. Ware, Tottenham, sent several interesting novelties, but not quite advanced enough for any award. Mr. Sinclair, gardener to the Marquis of Downshire, exhibited blooms of a reddish buff sport from *Bouquet Fait* named *Marquis Downshire*, the florets flat and spreading, rather thin, but promising. Mr. H. Elliott, Springfield Nursery, Jersey, showed several blooms of new Chrysanthemums raised from seed gathered last January. They were too small to receive any award, but a yellow recurving Japanese appeared distinct, and it was requested that it be shown again.

The most distinct of the varieties certificated were *Macaulay* and Mrs. J. Wright, both of which will probably become familiar exhibition blooms. *Macaulay* constitutes quite a new type, and judging by the better of the two blooms shown it is likely to come of good size. It has been not inaptly termed *Golden Endive*, and the peculiarly twisted florets are very suggestive of the ordinary curled *Endive*. Some of the older growers thought that dry hot summers were conducive to the production of sports, and it was rather strange that two sports from *Bouquet Fait* were shown at this meeting. The one named *Marquis of Downshire* is quite distinct, and is said to have been thoroughly tested; the other named *Marie Louise* was delicate and pretty, but too nearly resembled its parent to be of much value. The reflexed *James Carter* was greatly admired for its colour, but it was considered too small as compared with other good reflexed varieties. Possibly a certificate might have been obtained for it as a decorative variety had a plant been shown to indicate its habit. It is essential that this condition be enforced, as it is impossible to judge the decorative value of a small-flowered Chrysanthemum without seeing a plant.



## HARDY FRUIT GARDEN.

SELECTIONS OF FRUIT TREES.—We have frequently pointed out how unwise it is to delay ordering new trees till such times as the old ones are become quite worthless. When a tree gives signs of failing, and cannot be restored, or is not worth renovating, a new one should be ordered at once and gradually prepared for the vacancy whenever it occurs. Large trained trees can certainly be purchased from the nurseries, but they do not transplant so safely as do those grown in the garden where they are required. There are generally a few unoccupied spaces on the walls where young trees can be prepared for more important positions, and failing these Pears, Cherries, and even Peaches, Nectarines, and Apricots may be grown and trained for a year or two on

a sunny border. The nursery trees are principally prepared in the open ground, and there are no reasons why gardeners with their superior facilities cannot follow the same practice. Those who intend to plant fruit trees of any description should order and plant early, and thereby fare better at the hands of the nurserymen, the trees also being more likely to start well next season when planted early. The following selections, and which have been slightly influenced by the past two seasons' experience, may be of service to some of our readers.

APPLES.—Eighteen good dessert sorts, arranged somewhat in their order of ripening, consist of *Irish Peach*, *Beauty of Bath*, *Kerry Pippin*, *Golden Reinette*, *King of Pippins*, *Cox's Orange Pippin*, *Court of Wick*, *Claygate Pearmain* (more reliable than *Ribston Pippin* and nearly as good), *Margil*, *Old Golden Pippin*, *Reinette de Canada*, *Court Pendu Plat*, *Adam's Pearmain*, *Wyken Pippin*, *Northern Spy*, *Lord Burghley*, *Cockle's Pippin*, and *Sturmer Pippin*. A like number of culinary sorts consists of *Keswick Codlin*, *Lord Suffield*, *Manks Codlin*, *Stirling Castle*, *Alexander*, *Cox's Pomona*, *Lord Derby*, *Warner's King*, *Mère de Ménage*, *Peasgood's Nonesuch*, *Blenheim Pippin*, *Kentish Fillbasket*, *Northern Greening*, *Dumelow's Seedling*, *Alfriston*, *Bramley's Seedling*, *Winter Greening*, and *Norfolk Beefing*. For espaliers and cordons we can recommend the following mixture of dessert and culinary sorts:—*Adam's Pearmain*, *Blenheim Pippin*, *Beauty of Kent*, *Claygate Pearmain*, *Brad-dick's Nonpareil*, *Cellini*, *Cox's Orange Pippin*, *Court of Wick*, *Dumelow's Seedling*, *Ecklinville*, *Gravenstein*, *Herefordshire Pearmain*, *Golden Noble*, *Lord Derby*, *Grenadier*, *Kinz of Pippins*, *Lord Suffield*, *Hawthornden*, *Melon Apple*, *Bramley's Seedling*, *Mère de Ménage*, *Tower of Glamis*, *Peasgood's Nonesuch*, *Royal Somerscot*, *Reinette Van Mons*, *Waltham Abbey Seedling*, *Royal Pearmain*, *Sturmer Pippin*, *Ross Nonpareil*, and *Alfriston*. In most instances, and especially for strong soils, the dwarfing or *Paradise stock* is the most suitable for the latter selection.

PEARS.—The lists of these in common with Apples are much extended, many sorts being included in most catalogues that are not worth garden room. *Doyenné d'Été* is the first to ripen, but is very small and keeps badly. *Jargonelle* is not easily trained, but is the most luscious early Pear we have. *Williams' Bon Chrétien* does well on walls of various aspects, and also as bushes and standards; it keeps badly. *Beurré d'Amanlis* does well on walls of various aspects, and makes a fine pyramid or standard, it is a second early useful Pear. *Beurré Superfin* follows closely, and is a grand sort for either walls or pyramids. Next we have the fine *Pitmaston Duchess*, and this also does well either on wall or in the open. *Louise Bonne of Jersey* is an old favourite and well adapted for walls or for pyramids. *Brown Beurré* forms a good succession, this being closely followed by *Doyenné du Comice*. The last named is one of the most delicious Pears in cultivation, but is best on walls. *Maréchal de Cour* grows to a good size, and is of first-rate quality. *Marie Louise* everybody grows or ought to do. It does well in any form of training, and the fruit are of first-class quality. *Beurré Diel* is not so reliable as far as quality is concerned, but both wall trees and pyramids rarely fail to crop heavily. *Thompson's* is a good useful Pear, and the same may be said of *Napoleon*. Those who admire large sorts should grow *Van Mons Leon Leclerc*, and *Huyshe's Prince Consort* is a heavy cropping and fairly good variety. *Passé Colmar* is a serviceable Pear, and *Beurré Bachelier* does well on walls. *Beurré d'Aremberg* is a great cropper either on walls or pyramids, and the fruit keeps well. *Glou Morceau* all should grow, but it usually succeeds best on walls. *Knight's Monarch* is another old favourite, and the same may be said of the delicious little *Winter Nelis*. *Josephine de Malines* rarely fails to bear and keep well, and is best with wall protection. *Easter Beurré* does well against walls, and is a fine late keeping sort. *Olivier de Serres* and *Nec Plus Meuris* should have wall protection, and these are long keepers. *Bergamotte Esperen*, which completes our list, may be grown either in the open or against wall, and is an exceptionally heavy cropping late-keeping sort. Twelve useful Pears for walls are *Williams' Bon Chrétien*, *Beurré d'Amanlis*, *Pitmaston Duchess*, *Louise Bonne of Jersey*, *Doyenné du Comice*, *Marie Louise*, *Glou Morceau*, *Beurré Diel*, *Josephine de Malines*, *Winter Nelis*, *Easter Beurré*, and *Bergamotte Esperen*.

APRICOTS.—We can recommend six varieties—viz., *Ambrosia* or *St. Ambrose*, an excellent, early, and most prolific sort; *Large Early* reliable and good; *Hemskerk*, midseason, fine and constant; *Moorpark* midseason, of excellent quality, but liable to die piecemeal; *Shipley*, midseason to late, fine sort and to be depended upon; and *Powell's Late*, a capital variety that ought to be in every collection.

PEACHES.—Suitable for open walls are *Early Louise*, small, but early and good in quality; *Hales' Early*, probably the best early sort; *Dr. Hogg*, fine, second early; *Stirling Castle*, successional and very good in every way; *Bellegarde*, midseason, one of the best; *Violette Hative*, rather late and good; *Lady Palmerston*, large and sometimes very good; *Barrington*, late, but reliable; and *Sea Eagle*, handsome, late, and a sure bearer. *Royal George*, *Grosse Mignonne*, and *Alexandre Noblesse* succeed remarkably well in some gardens, but as a rule cannot long be depended upon.

NECTARINES.—These often fail where Peaches do well. *Lord Napier* is the earliest, but the fruit is frequently much scarred. Advance to succeed it is well worthy of a trial, while the old *Hunt's Tawny* is yet one of the most reliable. *Balgowan*, midseason, is a good sort; *Elrue* is still one of the best; and *Humboldt*, late, is sometimes profitable.

CHERRIES.—Good dessert sorts for either walls or the open ground are *Early Red Bigarreau*, *May Duke*, *Frogmore Early Bigarreau*

Bigarrean Napoleon, Black Tartarian, Elton, Governor Wood, and Reine Hortense. For culinary purposes the best are Morcello, Kentish, and Belle Magnifique, all of which do well as standards or against a cool wall.

**PLUMS.**—Good dessert sorts are July Green Gage, suitable for standards or walls; Denniston's Superb, good second early; Jefferson, very handsome and good for walls; Green Gage, suitable for standards or walls; Kirk's, rather late, very fine walls and sheltered fruit quarters; Transparent Gage, fine, midseason, especially good on walls; Reine Claude de Bayay, good for all positions; Guthrie's Late Gage, fine on walls; Coe's Golden Drop, good alike on wall and standard trees, keeps late; and Ickworth Impératrice, suitable for walls and keeps longer than any. Good culinary Plums are Early Prolific, small and early; Victoria the most reliable sort in cultivation; Czar, Washington, White Magnum Bonum, Pond's Seedling, Michelson's, Prince of Wales, Diamond and Winesour: all succeed as bushes or standards, and we consider Victoria and Pond's Seedling worthy of a place against an east wall.

**FIGS.**—Brown Turkey is the most reliable, White Marseilles being also hardy, prolific, and good in quality; Brunswick is larger than either, and quite as hardy, but it is a shy bearer; Black Bourgassotte has done well with us, though not quite so hardy as the foregoing.

**GRAPES.**—Royal Muscadine or Common Sweetwater is the variety most generally grown against sunny walls, and Black Cluster is a great bearer, the bunches and berries being small and sweet.

**MEDLARS.**—The Dutch grows to the largest size and is a good bearer, but the Nottingham is superior in point of quality.

#### FRUIT FORCING.

**PEACHES AND NECTARINES.**—*Earliest Forced House.*—The trees in this structure have been at rest for some time, the roof lights have been removed, the house thoroughly cleansed, the trees untied, pruned, dressed with an approved insecticide, re-arranged and tied on the trellis, the border surface dressed, and all is in complete order ready for a start when the time arrives. If, however, the roof lights have not been removed, care must be taken not to allow the soil to become dry at the roots of the trees, as this is sufficient to cause the buds to fall. If the trees are weakly, or with too many buds, as they generally are this season, a supply of liquid manure whenever water is necessary will be of great benefit. The surface soil also should be removed down to the roots, not disturbing them, replacing with 2 or 3 inches thickness of good loam, and if the soil be light, add a fourth of marl, with a bushel each of bone meal, soot, and wood ashes to every cartload of soil, thoroughly incorporated, making it firm, and giving a good watering. Borders that are rich in humus through heavy dressings of manure or liquid manure may be dressed with freshly slaked lime an inch thick, and mixed with the soil as deeply as practicable without disturbing the roots to any great extent, omitting the top-dressing before named. In treating borders it should be pursued on both the inside and outside. Complete the pruning and dressing, cleansing the house, &c., admitting air to the fullest extent possible. The outside border being thoroughly moistened, it may be covered with a few inches thickness of leaves, with litter to prevent their blowing about.

*Second Early-forced House.*—The trees are leafless, and should be pruned, after untying, dressed, and re-arranged on the trellis. This, with a thorough cleansing of the house, makes an end of all insects before they have time to find safe winter quarters. In pruning early-forced trees it is not desirable to cut away much wood, nor indeed trees of any sort at the winter pruning, confining it to removing any useless parts that have escaped the knife at thinning after the fruit was gathered, and any long unripened shoots may be cut back to a triple bud, making sure that the centre one is a wood bud, or to a wood bud on well ripened wood. Shoots, however, that are well ripened need not be shortened, and those of from 8 to 12 inches length should not be shortened under any circumstances, having usually a few wood buds at the base and one at the extremity, the rest being fruit buds. It is, however, a great mistake to retain much wood, which weakens the trees in flowering, and there is not space to train in the young growths without crowding. In other respects treat the trees, house, and borders as advised for the early house.

*Third Succession House.*—In this the trees also are leafless or nearly so. As the trees in this structure were rather vigorous beyond that needed to a full crop of large fruit, yet not so luxuriant as in our opinion to necessitate lifting or root-pruning, the lights have been continued over them, the house having been kept rather close by day and thrown open at night, which has browned or hardened the wood, and the roots being kept moist the buds have plumped well, so that the roof lights will be removed at once. Where the roof lights are not moveable care must be taken to prevent the soil becoming dry, and air must be admitted to the fullest extent, securing as complete rest as possible. Let no opportunity pass of pushing forward the pruning, dressing the trees, and having all needful work done.

*Later Houses.*—These may contain midseason varieties or late sorts, in each case having fire heat to assist in spring at setting and in the early stages of growth, or in unfavourable weather during growth. The trees are shedding their leaves, and it will be advisable to remove the roof lights as soon as the foliage is sufficiently advanced, but where green leaves hang long it is an indication of unripe wood, and the roof lights must not be removed for some time longer, and if this condition

prevails generally the trees should be lifted carefully and root-pruned. If this is performed judiciously it will not prejudice next year's crop, but it must be done whilst the foliage is still upon the trees, but with the wood firm, keeping the house rather close, the trees syringed, and the house shaded if the weather be bright. Under ordinary circumstances as to weather those precautions are not necessary. It is only when the trees are gross and the wood unripe that the careful treatment is requisite. In the case of young trees it will suffice to take out a trench one-third the distance from the stem the trees cover of trellis, and down so as to cut off all roots to the drainage, leaving the trench open for a fortnight, not allowing the soil in the radius to become so dry as to distress the foliage to a very severe degree of flagging, but not giving any water so long as the leaves maintain their persistence, and then the trench may be filled in firmly. This will check the tendency to a late growth and ripen the wood and buds.

*Unheated Houses.*—These may be arranged to afford a succession of fruit over a lengthened period, or may be planted with early, mid-season, or late varieties. If to afford a succession over as long a period as possible, obtain Alexander, \*Hale's Early, Dr. Hogg, \*Stirling Castle, Alexandra Noblesse, Bellegarde, \*Barrington, Walburton Admirable, and \*Sea Eagle. If more are wanted, Condor, Crimson Galande, Grosse Mignonne, or Belle Beauce, Noblesse, Royal George, Violette Hâtive, and Princess of Wales. Under glass Prince of Wales is very large, highly coloured, and good in quality—indeed, one of the very finest, but its constitution is not hardy enough for outdoor culture. Of Nectarines, secure \*Lord Napier, Hardwicke Seedling, Rivers' Orange, Milton, \*Pine Apple, Newton, Spencer, and \*Victoria. Those only requiring a few sorts may select those distinguished by a star. In making selection for unheated houses, have the following:—Early—Alexander, Hale's Early, and Dr. Hogg; Nectarines, Lord Napier, Goldoni is likely to prove a fitting companion. Midseason—Stirling Castle, Alexandra Noblesse, Bellegarde, and Belle Beauce; Nectarines, Hardwicke and Rivers' Orange. Late—Barrington, Princess of Wales, Walburton Admirable, Sea Eagle, and Gladstone; Nectarines, Pine Apple and Victoria. The structures should have south or south-west aspects. We have one a hundred feet long with a west aspect, which has been very satisfactory. East aspects are not nearly so good for fruit houses as westerly. The chief thing with trees in unheated houses is to train the growths rather thinly, so as to insure short-jointed wood, thoroughly solidified growth, to allow unobstructed light, and provide efficient ventilation. Of course, proper attention must be given to cleanliness and due supplies of aliment. There is also one other very important consideration, and one very often neglected—viz., retarding the blossom in spring as far as practicable. This we find best effected by removing the roof lights, and allowing them to remain off until the blossoms are swelling and showing colour. It also has a very beneficial effect on the trees by the cleansing influence of rain and snow; also in securing the thorough moistening of the soil. Such trees can be kept perfectly under control by occasional lifting and root-pruning as may be considered expedient. Over-luxuriance, or a tendency to late growth, is overcome by lifting, which should be done after the wood becomes firm, and whilst the foliage is still upon the trees. Intelligently practised lifting and laying of the roots near the surface, and firm soil is the surest remedy for trees that fail to set and stone full crops of fruit.

#### PLANT HOUSES.

*Cinerarias.*—The earliest plants are producing their flower stems, and will be found invaluable towards the end of November and during the following month. These should be stood on some moisture-holding material where a night temperature of 45° to 50° is maintained, and they will come forward rapidly. Give these plants clear soot water every time they need water, and syringe them liberally on the mornings of bright days. If this is not done they are very liable to flag if they occupy a sunny position, and in consequence soon lose their lower leaves if stood on a dry base. The next plants now growing freely in their largest pots may still occupy cold frames. Those for spring-flowering should be placed at once into 5 and 6-inch pots; if these are well cared for they will be valuable for conservatory decoration. For the latest supply place the most advanced plants from the last sowing out of pans into 3 and 4-inch pots, and the remainder into pans or boxes to be potted singly towards the close of the year.

*Calceolarias.*—These are growing rapidly since the weather has been cooler. The largest plants should be placed at once into 6-inch pots and stood on ashes in cold frames; others may be transferred into different sizes, as they need more root room. Be careful not to allow them to become root-bound before they are transferred into larger pots. The smallest of all now growing in pans may be placed in 2-inch pots. These plants do well in three parts good loam, the remaining part being composed of leaf mould, sand, and manure, about one-seventh of the latter. When the weather compels these plants to be housed they must occupy a cool house from which the frost is excluded. Fire heat ruins them, and the same may be said of arranging them on shelves or any position with a dry base. Destroy aphides directly they appear by fumigating with tobacco smoke.

*Scented Pelargoniums.*—These are invaluable in many gardens where greenery is needed during the winter in quantity for associating with flowers. From the present they should occupy a light position where a temperature of 50° at night can be maintained and a circulation of air admitted during the day. They must not be drawn up soft and weakly, or they will not last half so long in a cut state. If the pots are full of

roots give them clear soot water occasionally, and apply a little artificial manure to the surface of the soil. These plants are very subject to aphides, and fumigations of tobacco smoke turn the foliage yellow, rendering it useless, besides destroying the appearance of the plants. When these insects make their appearance they can easily be destroyed by dipping the plants in a weak solution of Fir tree oil, Fowler's insecticide, or any others that individual cultivators may prefer.

*Vallota purpurea*.—This is perhaps one of the worst treated plants in cultivation, for it is generally accorded some makeshift position when the weather compels protection inside. It will live in almost any position and with any treatment, but it is worthy of the best care and attention. It is as useful and equally as beautiful as any of the newer forms of Amaryllis. What can be more beautiful than a single bulb producing fifteen of its bright scarlet flowers on two spikes fully 2 feet high? To keep this plant in good condition give it a light position in any structure where frost is excluded, and water it with care, but never allow it to suffer by the want of supplies, for any attempt at drying it off means injury, if not ruin.

*Imantophyl ems*.—The whole of these plants should have completed their growth, and may occupy any cool position provided they are not overwatered at their roots. They should be kept on the dry side, only giving sufficient water to keep them fresh and plump. If they are too moist at their roots the tips of their leaves will go brown and their appearance will be sadly disfigured.

*Kalosanthes*.—Place these on a shelf close to the glass in the greenhouse; in fact, any cool house where they can be protected from frost, which is all that they need. This is necessary to keep them from growing, that is those that have had a clear season's growth. Water these plants carefully, give them no more than will keep their leaves and stems fresh.

*Early Bulbs*.—Roman Hyacinths and early Narcissus that have been removed from the ashes and have their foliage green by gradual exposure to light may now be brought gently forward in a temperature of 50° to 55°. Start them gently at first, for nothing is gained by hurrying them.

*Washing the Glass*.—If this has not been done inside lose no time, and well wash the woodwork in addition. Whitewash walls and make every portion of the house clean, so that they will be as light as possible for the occupants. It is surprising how much better plants do in houses that are rendered sweet and clean at short intervals, and how much lighter they are after this process has been completed. Not only is it necessary to wash the glass inside, but it should be thoroughly done outside after the removal of the blinds. In the neighbourhood of towns it is important that they be washed outside two or three times during the winter, for they quickly become covered with soot, and heavy rains fail to remove it. Clean all the houses inside before placing the plants under cover. If the inside is done the outside glass can be washed from time to time as convenient, so as to bring the two operations to a close as early as possible. If more attention was paid to cleaning houses thoroughly two or three times a year there would quickly be a marked improvement in the health and condition of plants generally.

*Winter Blinds*.—Thick canvas blinds for the protection of warm and intermediate houses are invaluable during cold weather, both from an economical point of view and for the well-being of Orchids and many other plants that are suspended only a short distance from the glass. They prevent the escape of heat to a large extent, the house can be kept warmer by employing them without having to resort to extra firing, which in very windy weather becomes necessary, even when the various structures are well supplied with pipes. Much injury is done to valuable plants by cold air striking upon them during the winter through the laps of glass, which can be prevented by the employment of thick blinds. These can be fixed at any time when convenient before the approach of cold weather.

## THE BEE-KEEPER.

### PRACTICAL BEE-KEEPING.—No. 21.

A SMALL swarm is never very profitable in the hands of the ordinary race of bee-keepers. A large swarm under the same management will give great results and large profits where the season and locality are favourable to the adoption of the swarming system of management. If these two small swarms issue or are taken from our stocks it is better to unite the two rather than to hive each swarm separately. If, again, built-out combs and a few frames of brood, taken from a stock well able to afford the loss, are given to a small swarm good results may be expected; but if no such combs are available, then in ordinary cases it is a wiser management to unite all small swarms with the least possible delay.

At swarming time bees are generally, but not by any means invariably, well disposed both to man and bees.

The usual precautions which must be adopted in many cases when uniting stocks need not in the case of swarms be practised. When a swarm issues, and the bee-keeper sees that it does not contain sufficient bees to become a profitable stock unless managed upon different lines to those generally followed in the apiary, he hives the swarm in the usual way, and gives the usual small amount of syrup, proceeding in every way as if the swarm so hived were of greater weight and would of itself be expected to form a stock. In the space of a few days another small swarm will perhaps issue, or possibly he sees an opportunity of purchasing a small swarm at a cheap rate. Upon obtaining this swarm he hives it in a skep and places the skep in close proximity to the hive in which the swarm to which he wishes to unite it is located. When the bees are settled in the hive, the skep being carefully raised and held a foot or more above a sheet fastened to the floorboard of the hive containing the swarm, and gradually sloping in a gentle decline to the ground, where it may be held fast by a couple of bricks placed upon the corners, he suddenly jerks the skep containing the swarm down to within an inch or two of the sheet, and then "pulls up short." Nearly every bee will at once be thrown from the skep on to the sheet and floorboard, and a few more shakes will effectually dislodge those bees which seem more determined than the rest to remain in the skep. In a minute or so a general movement ending in a continual march towards the entrance of the hive will be perceived, and in a very short space of time every bee will have disappeared within the portals of the new home.

The sooner the union is effected after the issue of the swarm which it is intended to unite to the swarm which was hived a few days or a week previous the better. The secret of the good reception accorded by the located swarm to the homeless swarm is that the bees of the latter swarm are well supplied with those "material comforts" which bees never affect to despise, whether gained by their own hard labour or by the distressing toil of the colonies. The latest period at which the union should be attempted in this easy method is the evening of the day of issue of the second swarm, and, if possible, the union should be effected as soon as the bees are knitted in the skep.

Certain bee-keepers think, and act on their ideas, that the safest time to unite swarms is at dusk. It may be successful, but for a bee-keeper who has any regard either for the bees themselves or for his personal comfort to follow this practice always seems to me surprising. At dusk bees crawl and rarely if ever rise on the wing; there is a time just before dusk when bees may easily and with comfort be united; but if evening draws quickly on, as it frequently does, the bee-keeper finds that his clothes are well dotted over with gorged bees, which, though not desiring to sting perhaps, are compelled in self-defence to make their presence felt. Many bees are lost in this way, many stings are received by the manipulator, and nothing is gained. This warning refers more especially to uniting driven bees in September, when the evening shades draw quickly on, and the interval between light and darkness is very short.

It need hardly be said that when uniting bees in September to established stocks a somewhat different plan to the one used when dealing with swarms must be followed, but it will be more useful and simple to consider the difference in the methods at a future time when "winter preparations" are being discussed.



As every swarm contains in its normal state one queen, casts often contain several; therefore, if the bee-keeper knows that one queen is in any way superior to the other or others the inferior queens should be destroyed, and the better one saved. If, however, the bee-keeper has no choice he may leave all the queens to fight it out, and the union will be equally successful. Again, if two small swarms, or three, or even more issue on the same day, the simplest plan is to destroy all the queens but one, preserving, of course, the best, or if the best is not known then the best by inference, and to throw all the swarms together in front of the hive which they are intended to people. In this case, also, the precaution of removing or destroying all the queens but one is not by any means necessary, but it is satisfactory to know that the best queen reigns, and that, as a great writer on bees says in effect, though the exact words have left my recollection, "the best fighting queen is allowed, by a wrong interpretation of the 'survival of the fittest' theory, to perpetuate that quality at the expense of qualities far more desirable from the standpoint of the practical bee-keeper."

Swarms may in the same manner and without any additional precaution be united to old stocks, the honey carried by the bees of a swarm for the purpose of furnishing the new home being a sufficient bribe to insure a glad reception. In the same manner a cast may be returned to the stock from which it has issued, and will very rarely indeed come forth again unless supering arrangements have been grossly neglected. If it does not issue again on the following day the bee-keeper may rest assured that the would-be emigrants have been received back in the old home, and will not again set forth until another summer's sun shines upon a new generation of bees.

If a bee-keeper cannot with facility unite swarms to stocks and swarms to swarms he had better at once recognise that he is like a cat in a dairy—in the wrong place! It is the easiest of all manipulations, and it is scarcely possible for any man who does not wish to supply the "missing link" in Darwin's famous chain of descent to fail in his first attempt to unite bees made friendly to bees by their homeless condition, and bees made friendly to bees by the handsome bribe of a supply of honey gratuitously given to the common store.—FELIX.

#### ODOURLESS FOUL BROOD.

AMONGST all the infectious diseases from which bees suffer the above is the most insidious. Phenol, salicylic acid, camphor, and in fact all and every remedy which has been known to cure the offensive form of foul brood, is powerless to cure or prevent the odourless form of the disease spreading. Its appearance is exactly like the other—viz.,appings of cells sunken, dark coloured dead brood coffee coloured and rosey, but it has no smell whatever, hence it is very apt to cause no alarm, and by interchanging combs one may get it into every stock before its nature is suspected, particularly when combs are changed in autumn and spring to save feeding.

I write this from bitter experience. I first noticed it in 1881, but as all authorities agreed that foul brood could not be mistaken on account of its offensive smell, and that it was the only infectious disease bees were liable to, I thought it must be chilled brood, then thought no more of it. In 1882 by changing combs I had it in nearly every stock—about eighteen; I then began to experiment with it. First, I shaved the caps off diseased combs, and put them into healthy stocks to see if it was infectious, and as the first brood hatched out of the diseased cells apparently healthy I at once concluded it was not infectious. In this I made an unfortunate mistake, for had I noticed the stocks until after the second batch of brood began to hatch I should have not only found it in the comb introduced, but all through the brood nest. I then took the queens from the diseased stocks and introduced them into healthy ones to see if the disease was in the queen alone, and as such stocks at once became diseased I at once concluded that the disease was congenital, and not really infectious. Here I made another error. I was supported in this in breeding queens in small nuclei, which turned

out diseased, while those bred in strong stocks proved healthy. Here let me say, that thinking the disease was not infectious, I may have unconsciously used infected combs in the nuclei, and combs free from taint in the full stocks.

In 1884 I thoroughly tried Hibbert's plan of fumigating with salicylic acid, feeding the acid in syrup (Cowen's plan of curing foul brood), also placing large pieces of camphor in the hives. I never saw much of the disease in the spring, the reason being that every autumn I get many driven bees and young queens, which were chiefly the bees that passed through the winter, and which is explained in the sequel.

In the spring of 1885, still thinking the disease lay alone in the queen, I sent a native British queen that I had obtained with driven bees the previous fall, that was producing foul brood, to Mr. Frank Cheshire, who at once wrote back saying her ovaries were full of bacilli, which was quite new to him; that the bacilli lay in strings and resembled links of sausages, whereas the bacilli of offensive foul brood resembled bits of sticks, crossed about anyhow, presenting a striking contrast. He asked for samples of the brood, which I sent him, and in which he found the same bacilli. During the summer I sent him a number of queens that I knew had produced healthy brood and bees in the spring—two were with swarms lived on perfectly empty but tainted combs—and he found the same bacilli in the ovaries of every one. One I sent him was from a stock that had not more than fourteen or fifteen foul cells in all, and he said he examined her ovaries without seeing any bacilli, and was going to report that she was healthy when he examined the last portion and found the same bacilli. This was a most important report to me in understanding this disease, and I think I was most fortunate, as well as the bee-keeping world, in having the services of such a skilful microscopical dissector as Mr. Cheshire.

Towards the close of the year 1885 I decided to try Cheshire's phenol remedy for foul brood, which he claimed to be a certain cure; so I thought if it will cure one kind of bacilli, why not another? and as, owing to the weather, no honey was coming in, I considered I had a splendid opportunity to get rid of it without destroying a comb. As I had lots of driven bees all healthy, I destroyed the old infected queens, united these, and fed upon phenolated syrup. The combs were filled with it; eighteen stocks were packed up for winter reduced from twenty-six, and twenty lots of driven bees were added; three of these eighteen never had been diseased, and they were the only healthy ones I had in the spring of 1886. The rest were either dead or weak, and all that were alive were diseased, and to make matters worse the three healthy ones found a way into one of the hives that had died and cleared out the phenolated syrup from the combs, and they also became diseased. This circumstance was valuable in its way, as it proved the spores of the disease can be carried in the honey from an infected hive. I concluded that the spores went in the honey to the queen and as aliment to the eggs, which became foul, producing in turn spores to again go to the queen and so pass through more eggs, in which I was confirmed in the fact that when bees are bringing in honey the stock increases in strength and shows little traces of disease, while when it ceases and the queen has to be fed from honey stored in infected combs the bees rapidly dwindle and the brood becomes very foul. Therefore I reasoned that if I turned the queen and bees into an empty hive or box, and if no honey was coming in, feed them for four days to induce the bees to build comb into which the queen could deposit her diseased eggs, and before they began to hatch turn the queen and bees into a clean hive on starters only, I ought to get clear of it and even cure the queens. This proved to be correct, for every case treated so has proved a cure, even curing in a most complete manner every diseased queen. I have at the present time several queens whose mothers were diseased last year, and as I write this I have over thirty fine strong healthy stocks inhabiting hives, frames, and quilts that have had diseased stocks in them, yet in looking over them this fall I could not find a single "foul" cell.

Having described the disease, I will now describe how to stamp it out if it is noticed in the spring or summer. Turn the bees and queen into an empty hive or box on the old stand, allowing them full liberty to fly where they wish in search of stores; if they can get honey freely they will need no more attention for four days; if not, then they must be fed for four days. In the meantime extract the honey from the combs, which after straining will be all right to eat, but the greatest care must be taken against any bee getting a sip of it. Then melt the combs down for wax—there is nothing gained in trying to save the brood—bake or boil every frame, quilt, and hive; if you have neither an oven or boiler to hold the latter rear it against the kitchen fire until the inside at least is well baked; now fix foundation guides not more than half an inch deep in the frames, and at the end of four days set it on the old stand, dump out the bees from the hive or box and let them run into the hive, and at once destroy the combs they have built. If honey is to be had the work is done; if not they must be fed, taking great care that all food and feeders are first boiled.

The plan I here describe is quite novel, never having to my knowledge been advocated as a means of curing foul brood or other forms of disease; though a plan much like it called the "starving" process has been much advocated. But, according to many reports, it seems rather uncertain; and well it may, as bees starve according to the amount of activity they exhibit. Thus they may drop down exhausted in twenty-four hours, or they may show no signs of weakness at the end of fourteen days, as I soon found in my experiments; hence the plan I recommend is more simple and certain.

If the disease is noticed in the fall never delay a day in suffocating

the bees, for they might die in winter or spring, and before discovered the other bees may have carried off the remaining stores into their hives, which would be certain to establish the disease in them; in fact, it is just in this manner in springtime that the disease is mostly propagated. The only advice I can give is to kill the bees at night, bury or burn every one, extract the honey and wax from the combs, and treat the hive, &c., as before directed. Keep a sharp eye on all the bees in your district; of everyone who keeps bees particularly inquire after those stocks that have not swarmed, for they are the ones to suspect, also all that are weak: a little neighbourly help or advice in this respect is well repaid.

It must not be supposed that the disease only exists in Hallamshire; in fact, I question whether there is a district in the whole of the British Isles that is free from it. By most it is mistaken for the offensive form of foul brood, and treated according to the directions for it. Hence they never succeed, and at once condemn the Cheshire cure and all other cures, and go in for total cremation, never dreaming that they have quite another disease. In my system of treatment nothing of value is destroyed, the combs yield their value in wax, and the bees build fresh ones for nothing if honey is to be gathered; and I can recommend it with the greatest confidence, as I have never known it to fail. True, my success only extends over two years, but then I can point to fifty healthy stocks where formerly diseased ones stood.

I have been very diffident about making this disease known for several reasons, one being I expected Mr Cheshire to publish it; another one, I expected as soon as I did do so, I should be deprived of all the credit in connection with the work. In this I have not been mistaken, as I gave a short account of the disease and how to cure it in *The Bee-keeper's Record* for July last, which would enable anyone to recognise and cure it. The result was, the editor of the *British Bee Journal* in less than two weeks after published an article in his journal explaining the disease, its appearance, gave directions to cure it, which I know will always fail, says he has long known of it, names it *Bacillus minor*, and refrains from saying that anyone has given another way founded on years of patient experiments and proved in results to be right. Now, as a matter of fact, Mr. Cowen has been a recognised authority on foul brood for years, he has written much on it; therefore if he previously knew or had distinctly noticed the disease I here refer to as being different from the offensive form, then would he not have mentioned it? As its discoverer, I claim the right to give it a popular name—viz., "odourless foul brood," and I call on Mr. Cheshire to give it a scientific one.—HALLAMSHIRE BEE-KEEPER.



All correspondence should be directed either to "THE EDITOR" or to "THE PUBLISHER." Letters addressed to Dr. Hogg or members of the staff often remain unopened unavoidably. We request that no one will write privately to any of our correspondents, as doing so subjects them to unjustifiable trouble and expense.

Correspondents should not mix up on the same sheet questions relating to Gardening and those on Bee subjects, and should never send more than two or three questions at once. All articles intended for insertion should be written on one side of the paper only. We cannot reply to questions through the post, and we do not undertake to return rejected communications.

**NAMING FRUIT.**—The attention of senders of fruit to be named, is respectfully directed to the intimation near the foot of page 373.

**Unhealthy Eucharises (Weybridge).**—We have examined the Eucharis bulbs with great care inside and out, and though they present all the symptoms of being attacked by the mite we are unable to find the enemy. It is possible your plants may have sustained a check that has arrested growth and incited decay by some treatment to which they have been subjected, but at the same time we are not satisfied that they have not been attacked by the pest, though the microscope does not reveal its presence in the examples that we have carefully examined.

**White Iris (E. A.).**—Iris florentina is one of the best free flowering white Irises for growing in clumps in the open ground, and the flowers are sweet. Soil free from stagnant water and made fertile to the depth of 18 inches will grow the plants well. If poor mix well decayed manure with it, and wood ashes; if very heavy add leaf mould and gritty matter freely; if light add strong loam. German Irises are of easy culture, and will grow well in any soil that would produce a good crop of Potatoes. You may plant at once, and cover the ground over the roots with cocoa nut fibre refuse, or a layer of littery or partially decayed manure.

**Asparagus Beds (A Country Parson).**—It will not benefit the old beds very materially to put on the sea sand and dig it in as deeply as the roots

allow. The best plan would be to leave them as they are, relying on what can be effected by manuring and liquid manure in the summer for a production of heads until the young beds, which we strongly advise you to make, are in bearing, using the sand for mixing with the top foot of soil, and in these plant the seedling plants in early April, or so soon in spring as they make 1 or 2 inches of growth. The fresh beds will come into bearing in the second or third year from planting, when the old beds may be destroyed. We will consider your suggestion.

**Gooseberry Cuttings (Amateur).**—These may be made and inserted as soon as the leaves fall or can be easily rubbed from the shoots. The cuttings should be as strong as possible, firm, and about 12 or 14 inches long. All the buds should be pruned clean away, with the exception of the topmost four, previously to planting. The cuttings may be put in about 6 inches asunder, in rows a foot apart. By the next autumn there will be two or three good shoots on each cutting, and these must be pruned down to about four eyes or buds on each shoot. Unless particularly wanted to plant in their final stations, they should remain another season in the cutting beds; they will then be strong bushes, and deserving a permanent place.

**Cherry Leaves Blistered (Somerset).**—The leaves are attacked by a leaf-mining insect, the larva of a minute moth, probably *Argyromyces clerckella*, which is much smaller than the Pear tree blister moth, *Tinea clerckella*, that is cause of the black blotches that often appear on the leaves in the autumn. In the leaves you have sent eggs were deposited some time ago, and these hatching, the larva penetrated the under cuticle, eating the parenchyma and tunnelling through the leaf, leaving the two surfaces untouched—at least, until the miners emerge in the autumn. They pass the winter in the chrysalis state. All the leaves of infested trees should be burned and the surface soil removed for some distance from the stems, a good dressing of soot given, and fresh soil added.

**The Chrysanthemum Leaf Miner (South London).**—The "marks in the leaves" are caused by the larva of a small fly, *Tryptera artemisiae*, also known as *Acidia artemisiae*, and *Tephritis artemisiae*. The eggs are deposited in the leaves, and the resulting larva burrows within their interior, eating out the substance in the same way that the grubs do in Celery leaves, these being the larva of *Tephritis onopordinis*. The affected Chrysanthemum leaves should be gathered and burned, or the enemy will emerge, change into the chrysalis state, pass the winter in the soil, escape in the winged form in early summer, and again attack the plants. If these cannot be grown in another and distant part of the garden next year, the ashes on which the pots have been arranged should be scraped off, and a fresh thick layer provided for the next plants.

**Insects Destroying Cyclamen (W. B.).**—The species now sent has nothing whatever to do with the insects which gave you trouble previously. It is a beetle in the larval condition, one of the weevils called the red-legged, or *Oti rhynchus tenibicus*, allied to the more common Vine weevil. The specimens sent are nearly adult, and after passing the winter as pupae, they emerge as beetles during the spring, and gnaw the buds, shoots, and young leaves of the choicer fruit trees, such as the Peach and Apricot. Subsequently the females deposit eggs on the earth, or beneath it, and the maggots feed upon the roots of the Currant, Raspberry, and other shrubs, also upon vegetables and flowers, and especially those of a succulent nature. The difficulty of dealing with them arises from the fact that their presence is often unknown till the mischief is well nigh accomplished, but quassia water is said to kill them, also diluted ammoniacal liquor. As we have previously suggested, all compost you use for potting should be sufficiently scorched to destroy all insect life, and the fertility of the soil will be increased rather than impaired by the process.

**Perennials for Town Garden (Brixton).**—You give no idea of the number you require. The following have been found to thrive satisfactorily: *Alyseum saxatile*, *Ajuga alpina*, *Agrostemma coronaria* vars., *Adonis vernalis*, *Alstromeria aurantiaca*, *Iberis saxatilis*, *Iris reticulata*, *I. germanica*; *Lilium colchicum*, *candidum*, *Martagon*, *chalconicum*, and *lancifolium* vars.; *Hepatica angulosa*, *H. triloba* in variety, *Lychnis Haageana* and its variety *splendens*, *Lythrum roseum superbum*, *Mimulus roseus pallidus*, *Paeonia albiflora* and *officinalis*, which are splendid for town gardens; herbaceous *Phloxes*, *Polemonium caeruleum*; *Primula acaulis*, double lilac, purple, crimson, white, and sulphur varieties; *P. auricula* vars.; *Pulmonaria officinalis*, *Perethrum* vars., *Salvia nemorosa*, *Tradescantia virginica*, *Spiraea filipendula*, *Thalictrum anemoneoides plenum*, *Trollius europæus*, *T. napellifolius*, and *T. asiaticus*, *Tritoma Burchelli*, *T. uvaria* and its variety *glaucescens*, *Tussilago Farfara variegata*, *Vinca elegantissima*, *Hesperis matronalis floro-pleno*, *Geum coccineum grandiflorum*, *Fritillaria imperialis*, *Galanthus nivalis* and *G. plicatus*, *Erigeron grandiflorus*, *Draba aizoides*, *Dodecatheon Meadia*, *Dielytra spectabilis*; Pinks, Carnations, and Picotees; *Delphinium formosum*, *D. Belladonna*, *D. alopecuroides*, *Convallaria majalis*, *Chrysanthemums*, *Cheiranthus Marshallii*, *Campanula aggregata*, *C. pulla*, *C. cserpatica*, *Anbrietia deltoidea grandiflora*, *Anemones*, *Columbines*, *Anemones*, and *Arabis albida*.

**Oleanders not Flowering (E. Mossley).**—According to your description of them the wood of your plants has not been ripened. It is quite true the plants require much water when growing, but they also need rest. The Oleander naturally is a marsh plant and a dry-baked mud plant alternately. It blooms uniformly at the points of the shoots, made and ripened the previous season. These facts furnish the *rationale* of successful culture. Any light soil may be used when the plant is young, but when established the soil should be good stiff loam, with a fair portion of decayed cow-dung. The treatment, however, is more important than the soil. Here, for instance, is a plant cut down, and commencing to grow in March; encourage it as much as possible with water and a fair amount of heat. Thin out the young shoots, so as to let those left have plenty of air and light. No stopping of shoots intended to bloom next season must be thought about. Wherever grown, harden off so as to get the plants out of doors by the beginning of August, and for a few days keep them in a shady place; then full in the sun; watering as they require it. By the middle of September place them against a south wall, and give not a drop more water than will keep the leaves from flagging. Take means to prevent their being

soaked with rains. House before frost; a cool greenhouse will do. Keep them dryish and cool all the winter; and as soon as the heat of the spring increases, or you put them into heat, then water must be gradually given; and as fresh growth commences the flower-buds at the points will show themselves. When the plants are intended to bloom every year, there must be a number of young shoots coming on to replace those that are flowering, which may be cut out as soon as the flowering is over, and that will throw more strength into the succession shoots, which must be managed as above.

**Vines Unsatisfactory (A Gardener).**—The Vines will need thorough renovation of the border so as to rejuvenate them. From the crops of Grapes being a "long way from satisfactory," and the bunches "shanking badly," the roots are in a very unfavourable rooting medium; and no wonder, as pigs that have died on the farm are buried in it, and night soil has been put upon it. Pigs and night soil are poisonous to Vines when applied so recklessly. Animal matter must be decomposed and pulverised with lime and soil, and night soil mixed with wood ashes to become safe fertilisers, they then form a valuable manure. In the absence of any roots near the surface it would be of no use applying rape cake or other manure, and it would be sheer waste to do so. New roots are wanted, and until they are produced the Vines will never yield good Grapes. The proper way to proceed would be to remove the soil down to the roots, and if the drainage be good it would only be necessary to take the old soil from amongst the roots and lay them in fresh material nearer the surface. As the Vines have only an outside border care will be needed so as not to injure the roots; indeed all should be preserved as far as practicable, and they should be kept as much as possible from the atmosphere. If the drainage be bad it ought to be rectified, which may necessitate the lifting of the Vines and remaking the border. If not in very bad condition it would perhaps be sufficient to take part of the old soil away, bring up some of the roots, and add new soil as you propose. In no case should the uppermost roots be deeper than 4 inches, mulching with the same thickness of short but not soapy manure. If the leaves are not off the Vines it would be advantageous to do the work now. Failing any attempt at lifting, a dressing of lime a couple of inches thick may be given, and mixed with the soil as deeply as can be done without disturbing the roots, taking advantage of any roots lying near the surface or proceeding from the collar to raise them and lay them in the fresh soil, from 4 to 6 inches deep. If you could pick out the soil for a yard or more around each Vine and quite up to the stem, replacing it with fresh material, fresh roots would be produced that would permeate the soil, changed by the lime into a more suitable and abundant source of food. Encourage fresh growth on the Vines another season, but do not crowd the foliage, a good spread of foliage exposed to light being a good preventive of shanking. No parcel has reached us.

**Making Grape Wine (Inquirer).**—Your letter did not reach us until after our last issue was published. Though Sweetwater Grapes are not the best for wine-making, still, as you observe, "something can be made of them." A very good wine can be made from Grapes which do not attain their perfect maturity in the open air in this country. The fruit should be allowed to hang as long as it is likely to derive any benefit in the way of ripening, and when it is ready the bunches are to be gathered and laid carefully, so as not to bruise the berries. The berries are to be picked separately from the stalks, discarding all that are in any way decayed. Measure the fruit as it is put into the fermenting tub, and to every 15 gallons of fruit add 1 gallon of soft water. Stir and bruise the fruit, and after standing for twenty-four hours strain and press the fruit through a hair cloth or coarse canvas bag, subjected to pressure. Now test the liquor by the saccharometer, and bring up the gravity to 120 by the addition of sugar, every pound of sugar raising the density 35 or 36. Let the whole be well stirred, and add 1 oz of argol to every 3 gallons of must. Stir the must every day, morning and evening, and when the density falls to 80 and the fermentation becomes languid the cask is to be bunged up, and the wine bottled off in the month of March following. We append a figure of a saccharometer, the instrument having been obtained from Messrs. Cetti, opticians, Brook Street, Holborn, London, at a cost of 3s. 6d. Each space between the figures should be multiplied by 5, thus, 80 multiplied by five records a gravity of 150. Argol, which is a combination of tartaric acid and potash, and called bitartrate of potash, can be had from chemists.

**Fir Tree Branches Withering (D. W.).**—As we understand your letter, the trees, of which the leaders are dying, were about 6 feet high when transplanted. In that case unless they had been grown thinly and in good condition for removal, there would be great risk of some of them falling during the first and second years afterwards, especially as the summers were the reverse of favourable for newly planted trees. Scotch Firs and Austrian Pines that are allowed to grow large in close rows often fail to make satisfactory progress after removal. If we have not indicated the cause of the leaders withering, the Pine-destroying beetle, *Hylurgus piniperda*, is possibly the originator of the evil. It is very small, and drills a hole into the shoot, enters the pith, eating its way upwards through the terminal bud, which it destroys. We have seen much injury caused by this enemy to Pine trees, though we cannot trace its working in the dry-shrank specimen you have sent. The rings on the shoots are formed by the axis of growth pushing right through the calyx of the buds, leaving this grasping the shoot and strangling it. Possibly the dry weather has had something to do with the non-decay of the scales and tissue. If you are careful you can draw the rings up the shoots, and in that way remove them. They have nothing whatever to do with the withering of the leaders sent, and marked No. 1.

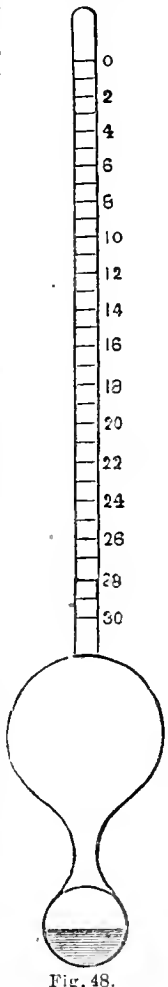

Fig. 48.

**Names of Fruits.**—The names and addresses of senders of fruit to be named must in all cases be enclosed with the specimens, whether letters referring to the fruit are sent by post or not. The names are not necessarily required for publication, initials sufficing for that. Only six specimens can be named at once, and beyond that number cannot be preserved. (Colley).—5, Maréchal de Cour; 10, Van Mons Levan Leclerc; 11, Easter Beurre; 13, Knight's Monarch; 14, Suzette de Bay; 15, Beurre Diel. (A. P. T., Lyndon).—1, Bergamotte Esperen; 2, Easter Beurre; 3, Josephine de Malines. (H. J. P.).—1, Baddick's Nonpareil; 2, Royal Pearmain; 3, Court Pendu p't; 4, Nonouch; 5, Cellini; 6, Cox's Pomona. (A Subscriber).—Sorry we cannot identify either; they are probably local varieties. (G. T.).—1, Winter Nelis; 2, Duchesse d'Angoulême; 3, Comte de Lamy; 4, Groom's Princess Royal; 5, Red Doyenné; 6, Forelle. (J. C. M.).—1, Golden Winter Pearmain; 2, King of the Pippins; 3, London Pippin; 4, Stirling Castle; 5, Aromatic Russet; 6, Bishop's Thumb. N.B.—In consequence of Dr. Hogg's absence from London, fruit cannot be named by him till after the middle of November.

**Names of Plants.**—We only undertake to name species of plants, not varieties that have originated from seed and termed florists' flowers. Flowering specimens are necessary of flowering plants, and Fern fronds should bear spores. Specimens should arrive in a fresh state in firm boxes. Slightly damp moss or soft green leaves form the best packing, dry cotton wool the worst. Not more than six specimens can be named at once. (B. C. D.).—1, Rudbeckia Newmanni; 2, Enothera biennis; 3, Aster horizontalis; 4, Tanacetum vulgare. (T. L.).—Dacrydium Franklini. (T. H.).—1, Pelargonium denticulatum; 2, Pelargonium crispum; 3, Pelargonium tenuifolium. (Eucharis).—Such forms are occasionally seen, but seldom so regular as yours.

COVENT GARDEN MARKET.—OCTOBER 26TH.

PRICES remain the same, with business stagnant.

PLANTS IN POTS.			
	s. d.	s. d.	s. d.
Aralia Sieboldi, dozen ..	6	0	12
Arbor vitæ (golden), dozen ..	6	0	9
" (common), dozen ..	0	0	0
Asters, dozen pots ..	3	0	6
Azalea, dozen ..	0	0	0
Begonias, dozen ..	4	0	9
Capsicum, dozen ..	6	0	9
Chrysanthemums, dozen ..	4	0	12
Cineraria, dozen ..	0	0	0
Dracena terminalis, doz. ..	30	0	60
" viridis, dozen ..	12	0	24
Erica, various, dozen ..	9	0	18
Euonymus, in var., dozen ..	6	0	18
Evergreens, in var., dozen ..	6	0	24
Ferns, in variety, dozen ..	4	0	18
Ficus elastica, each ..	1	6	7
Foliage Plants, var., each ..	2	0	10
Fuchsia, dozen ..	3	0	to 9
Geranium (Ivy), dozen ..	0	0	0
" Tricolor, dozen ..	0	0	0
Gladolus ..	0	0	0
Hydrangea, dozen ..	9	0	12
Lilies Valley, dozen ..	0	0	0
Lilium lancifolium, doz. ..	12	0	18
" longiflorum, doz. ..	0	0	0
Lobelia, dozen ..	0	0	0
Marguerite Daisy, dozen ..	6	0	12
Mignonette, dozen ..	3	0	6
Musk, dozen ..	0	0	0
Myrtles, dozen ..	6	0	12
Palms, in var., each ..	2	6	21
Pelargoniums, dozen ..	0	0	0
" scarlet, doz. ..	3	0	9
Spiræa, dozen ..	0	0	0
CUT FLOWERS.			
	s. d.	s. d.	s. d.
Abutilons, 12 bunches ..	2	0	to 4
Anemones, 12 bunches ..	0	0	0
Arm Lilies, 12 blooms ..	3	0	6
Asters, 12 bunches ..	2	0	6
" French, bunch ..	1	6	2
Bouvardias, bunch ..	0	6	1
Camellias, blooms ..	3	0	6
Carnations, 12 blooms ..	1	0	2
" 12 bunches ..	4	0	6
Chrysanthemums, 12 bchs. ..	2	0	6
" 12 blooms ..	1	0	6
Cornflower, 12 bunches ..	1	6	3
Dahlia, 12 bunches ..	2	0	4
Daisies, 12 bunches ..	2	0	4
Eucharis, dozen ..	3	0	6
Gardenias, 12 blooms ..	2	0	5
Gladiolus, 12 sprays ..	1	0	1
Hyacinths, Roman, 12 ..	0	0	0
" sprays ..	0	0	0
Iris, 12 bunches ..	0	0	0
Lspageria, white, 12 ..	1	6	8
" blooms ..	1	0	1
Lspageria, coloured, 12 ..	1	0	1
" blooms ..	4	0	6
Lilium longiflorum, 12 ..	4	0	6
" blooms ..	1	6	3
Lilium lancifolium, 12 ..	1	6	3
" blooms ..	0	0	0
Lilies, White, 12 bunches ..	0	0	to 0
" Orange, 12 bunches ..	0	0	0
Marguerites, 12 bunches ..	2	0	6
Mignonette, 12 bunches ..	1	0	3
Myosotis, 12 bunches ..	1	6	3
Narciss, 12 bunches ..	0	0	0
" White, English, bch. ..	0	0	0
Pansies, 12 bunches ..	0	0	0
Peas, Sweet, 12 bunches ..	1	6	3
Pelargoniums, 12 trusses ..	0	9	1
" scarlet, 12 trusses ..	0	3	6
Poinsettia, 12 blooms ..	0	0	0
Primula (single), bunch ..	0	0	0
" (double), bunch ..	0	9	1
Polyanthus, 12 bunches ..	0	0	0
Ranunculus, 12 bunches ..	0	0	0
Roses, 12 bunches ..	4	0	9
" (Indoor), dozen ..	0	9	1
" Tea, dozen ..	1	6	8
" red dozen ..	0	0	0
" de Moiss, 12 bunches ..	0	0	0
Stephanotis, 12 sprays ..	4	0	6
Tropæolum, 12 bunches ..	0	0	0
Tuberose, 12 blooms ..	0	6	1
Tulips, dozen blooms ..	0	0	0
Violets, 12 bunches ..	1	0	1
" (French), bunch ..	1	0	1
" (Parma), bunch ..	3	0	3
FRUIT.			
	s. d.	s. d.	s. d.
Apples, 1/2 sieve ..	1	6	to 3
" Nova Scotia and ..	0	0	0
" Canada barrel ..	0	0	0
Cherries, 1/2 sieve ..	0	0	0
Cobs, 100 lbs. ..	50	0	6
Figs, dozen ..	0	0	0
Grapes, per lb. ..	0	6	2
Lemons, case ..	10	0	15
Melon, each ..	0	6	1
Oranges, per 100 ..	6	0	to 12
Peaches, dozen ..	2	0	6
Pears, dozen ..	1	0	1
Pine Apples, English, ..	1	6	2
" per lb. ..	1	6	2
Plums, 1/2 sieve ..	1	6	2
St. Michael Pines, each ..	3	0	5
Strawberries, per lb. ..	0	0	0
VEGETABLES.			
	s. d.	s. d.	s. d.
Artichokes, dozen ..	1	0	to 2
Asparagus, bundle ..	0	0	0
Beans, Kidney, per lb. ..	0	3	0
Beet, Red, dozen ..	1	0	2
Broccoli, bundle ..	0	0	0
Brussels Sprouts, 1/2 sieve ..	3	6	4
Cabbage, dozen ..	1	6	0
Capsicum, per 100 ..	1	6	2
Carrots, bunch ..	0	4	0
Cauliflowers, dozen ..	3	0	4
Celery, bundle ..	1	6	2
Coloworts, doz. bunches ..	2	0	4
Cucumbers, each ..	0	4	0
Endive, dozen ..	1	0	2
Herbs, bunch ..	0	2	0
Leeks, bunch ..	0	3	0
Lettuce, dozen ..	0	9	to 0
Mushrooms, punnet ..	0	6	1
Mustard and Cress, punt. ..	0	2	0
Onions, bunch ..	0	3	0
Parsley, dozen bunches ..	2	0	3
Parsnips, dozen ..	1	0	0
Potatoes, per cwt. ..	4	0	5
" Kidney, per cwt. ..	4	0	0
Rhubarb, bundle ..	0	2	0
Salsafy, bundle ..	1	0	1
Scorzenera, bundle ..	1	6	0
Seakale, basket ..	0	0	0
Shallots, per lb. ..	0	3	0
Spinach, bushel ..	1	6	2
Tomatoes, per lb. ..	0	4	0
Turnips, bunch ..	0	4	0





PROGRESS.

DARE we venture to mention such a word as progress in connection with agriculture at the present time? Yes, we certainly may do so, for it is an immutable law of Nature that nothing under her control remains quiescent, it either improves or decays. Change, incessant change, there always must be, and whether such change proves beneficial for the farmer or the reverse depends in no inconsiderable degree upon himself. If under the heavy cloud of depression that is now hanging over us, we were to own ourselves beaten and withdraw from a struggle which becomes increasingly arduous year by year, there would soon be an end of agriculture in this country, for an increasing demand for farm produce would receive prompt attention from importers, who would hasten to reap the rich harvest to be gained by supplying the wants of so wealthy a nation as this is.

But the British farmer is not wont to yield lightly to difficulties, and however easy-going he may have been in the "good times" he is now on his mettle, and strenuous efforts for all possible improvements are being made, and the lessons of adversity will indeed prove to be invaluable if they enable him to overcome the difficulties of his position and to hold his own in the keen competition with foreign produce in which he is now engaged.

As a sign of progress we gladly note the lively interest taken by farmers generally in improved sorts of corn. We may go farther and acknowledge a feeling of surprise at the spirit of enterprise shown in the purchase of pedigree Wheat and other pure samples of Wheat, Barley, and Oats. We make our home farm in fact a nursery for raising and supplying our off farms with the best sorts of corn. We have been so successful in doing this that we were induced to exhibit some bunches of Wheat on our market stand. They attracted much attention and led to many warm discussions of the relative merits of one sort with another, and we found that however enthusiastic farmers were over a fine sample of corn, prudence kept them from indulgence in giving fancy prices for it. At our last market we purchased some 15 quarters of Scholey's Square-head Red Wheat at 30s. We were asked 40s. for it, but while eager to secure it for sowing we felt safe in not going beyond market value. The result proved us to be right, and we were so fortunate as to secure this Wheat in time for sowing. It weighed 67 lbs. a bushel, and the yield was 5 quarters an acre. It will thus be seen that in both weight and measure it was much above the average. There are, however, plenty of farms where the yield has been equal to this. While writing this article we have received samples of corn from Kent, of which the Red Wheat yield was 5 quarters, and the weight per bushel 65 lbs.. We know an instance where the Wheat yield reached as high as 7 quarters an acre on a Suffolk farm. Take such a crop at market value now, and the grain is worth £10 10s., to which we may certainly add £5 for the straw, and we may certainly claim that £15 an acre for Wheat is an unmistakable sign of progress. Yet we are told that Wheat-growing in this country will be a thing of the past: may we not qualify this by saying that bad practice in Wheat-growing here will soon be

ended? In our own practice we do not sow Wheat upon land that is out of condition, and we have no doubt that the failure of many farmers was caused by doing so. As a plea for rent reduction we are told that land is cold, thin, poor, hungry, and wet. We are always ready to assist a tenant with drainage to correct the cold and wet condition of his land, but it rests with him to plough deeply and apply manure.

We may certainly take it as a sign of progress when men of energy, intelligence, and enterprise continue to make farming answer under the difficulties which beset their work now. At one time farming was said to be so profitable an undertaking that anyone might turn to it with advantage; that time is certainly gone by, and those who went into farming without sound practical knowledge have had to pay the penalty of their rashness in undertaking a business of which they are so ignorant. It may appear like a bit of grim satire to say that the failure of such men is a sign of progress, yet we do say so. The time for easy-going practice in any calling has gone by. In these days of keen competition the best men come to the front and remain there to grapple with and overcome difficulties which prove insuperable to less able men.

(To be continued.)

WORK ON THE HOME FARM.

Especial attention is being given to the cleaning and dressing of corn for market, for we have found the sale of corn much affected by care in dressing. For this reason we never purchase old corn-dressing machines, but have new hand machines as they are required. We get excellent machines from Mr. Robert Boby, of Bury St. Edmunds, with fans and a complete set of screens for all sorts of corn and fine seeds. In East Anglia these machines are held in such high esteem that to "Boby" corn is a common expression when excellence in dressing is spoken of. The hand machine we recommend is sold with a guarantee to screen sixty bushels of corn an hour, but to do this well we find the corn must be tolerably clean beforehand. We have therefore to take equal care in our selection of a threshing machine. Old threshing tackle can now be bought at so low a rate that it is quite exceptional to be able to hire a really good set of tackle. We have to hire several, because the farms which we have in hand are so far apart, and we find much difference in the condition of the corn after threshing is done. There is no doubt that the bearings of old machines become so much worn that the work cannot be well done, and some Barley was so badly screened by a drum used at one of our farms that it had to be passed twice through a new Boby screen before it was fit for market. Tail corn can always be used advantageously for pigs and poultry, and none of it should be left in the bulk of corn that is screened either for sale or sowing. We hope now there is an end of using tail corn for seed, yet at one time the practice of sowing such inferior seed was common enough, and the result was an inferior crop.

We are taking pains to have only pure corn seed sown upon our farms, and we have been at much trouble and expense in obtaining the best known sorts. The best seed, the best manure, thorough drainage, clean land, deep cultivation, a fine seed bed, timely sowing, these are the indispensable points of culture to which attention is given, and which go far to render corn-growing successful.

METEOROLOGICAL OBSERVATIONS.

CAMDEN SQUARE, LONDON.  
Lat. 51° 32' 40" N.; Long, 0° 8' 0" W.; Altitude, 111 feet.

DATE.	9 A.M.					IN THE DAY.				Rain	
	Barometer at 32° and Sea Level.	Hygrometer.		Direction of Wind.	Temp. of soil at 1 foot.	Shade Temperature.		Radiation Temperature			
		Dry.	Wet.			Max.	Min.	In sun.	On grass		
1887.											
October.											
Sunday .....	16	30.449	40.5	39.4	N.	45.4	52.3	35.1	85.8	29.3	In.
Monday .....	17	30.579	47.0	44.1	N.	45.3	51.1	39.7	94.3	33.6	—
Tuesday .....	18	30.610	43.0	41.9	W.	45.4	53.1	36.2	77.6	30.2	—
Wednesday ..	19	30.502	47.4	43.2	N.W.	46.2	49.1	42.9	70.2	42.6	—
Thursday .....	20	30.337	43.9	44.4	W.	45.8	54.8	35.2	62.4	30.4	—
Friday .....	21	30.472	43.3	40.5	N.	46.2	53.6	34.7	84.0	27.3	—
Saturday .....	22	31.536	31.5	31.6	Calm.	45.1	45.4	28.2	62.2	23.8	—
		30.512	42.7	40.7		4.55	52.5	35.1	76.8	31.0	—

REMARKS.

16th.—Fine and bright all day.  
17th.—Bright, pleasant day.  
18th.—Foggy till nearly midday; fine afternoon.  
19th.—Cloudy morning; pleasant sunny afternoon; clear night.  
20th.—Fine, but almost without sunshine.  
21st.—Fine, bright and warm.  
22nd.—Cold, with dense fog necessitating gas till noon, then fine; fog again in the evening.  
A rainless autumn week. Fine and pleasant except during the fogs of the 18th and 22nd. Temperature about 5° below the average, but more than a degree higher than that of the preceding week.—G. J. SIMONS.



## COMING EVENTS

3	TH	Havant and Henfield Shows.	
4	F	Crystal Palace Show (two days).	
5	S		
6	SUN	22ND SUNDAY AFTER TRINITY.	
7	M	Surrey Chrysanthemum Show.	[St. Neots Shows.
8	TU	R.H.S. Committees at 11 A.M.; Kingston, Brighton, Highbate, and	
9	W	National Chrysanthemum Society; Bath, Croydon, Ascot, and Cornwall Shows.	

## THE FERTILISATION, STONING, AND SWELLING OF GRAPES.

**A**BOUT a year since, while giving the results of my experience in the direction indicated, I made inquiries, and caused some little attention to be devoted to the subject; with your permission I will now again trouble you with further particulars. I send a few samples of Grapes for examination, seeing and tasting in this case affording the best means of estimating the value of fertilisation. Before dealing with these varieties and their peculiarities a few lines on their treatment and the present appearance of the crop will not be inappropriate. Speaking generally, the crop is satisfactory, only in a very few instances are the Vines too heavily laden. Last year I erred very much in this respect, and every Vine so overcropped shows the effects of it very plainly now.

Beginning with my Gros Colman house, the Vines on their own roots; for the first time I have the Grapes beautifully coloured (see No. 4 sample sent). Wishing to keep them into May, they were thinned more freely than is customary when the crop is intended for winter use. The Vines were started on February 1st, the border having had a heavy dressing of lime in the autumn, and another application at the time of starting. As the Grapes hang I have no serious fault to find, for the crop is good, still there are but few berries with the full complement of stones (four). But if the crop is good at the present moment I am not satisfied, having regard to the keeping properties of the Grapes, nor shall I be until I get the normal number of stones in each berry. I have no fear of premature collapse if the berries have only two seeds; one is not enough, one-seeded berries shrivelling a little on one side. Seedless Grapes will not keep after they are ripe. Having done all I thought necessary to the roots of the Vines I did not stop at that, but every bunch was very carefully touched with a soft brush, using different varieties of pollen. At the date of writing it does not require a very practised eye to detect the influence of the Black Hamburgh pollen; a vast improvement resulted from this, as is apparent from the samples sent. Muscat of Alexandria pollen also left its mark, but I think the grandest result of all is from the Madresfield Court. My regret is that with all this care there is a deficiency of stones in the Grapes. Before leaving this house of Gros Colman I may say, though the crop is not heavy, there are nine bunches to eleven laterals, or from twenty to twenty-four bunches on a Vine, all for late keeping. The foliage is very fine and still holds on, but changing colour, and the bright autumn tints are attractive on a sunny morning. Madresfield Court grown in two corners of the house are the best coloured bunches

No. 384.—VOL. XV., THIRD SERIES

I ever saw, and look like keeping; no cracks; bunches not large, nor berries either, but there are fifty bunches on the two Vines, and considering the weight the Grapes are, I think, as good as could be reasonably expected. For heavier bunches and larger berries of Gros Colman I have to go to the Muscat stock; the same fault, however, is apparent in the stoning. For colour the berries are the intensest black I have seen.

Muscat of Alexandria (see No. 5).—Of this fine variety the fruit is sound and will keep till April. In the liming process here I was very liberal, even to giving the Vines an extra dose after thinning, and all the bunches were fertilised. Though these are not large all round I am tempted to feel somewhat proud of the crop at times, or, at least, until I bethink me of the noble examples at Longleat and Bath. Shrivelling I am aware is a great drawback to this most luscious Grape, but from this calamity I have escaped much better than usual, and am positive that front ventilation has a close connection with shrivelling; indeed front air admitted freely when the house is hot will materially accelerate it. One particular Vine suffered through want of water at the roots, but without doubt the fruit on this Vine would not have shrivelled so soon if air were not admitted through the front ventilators. After many experiments in feeding Vines I have come to the conclusion that for top-dressing dry night soil, lime, and soot are good; for liquid feeding, sheep or cow dung form the best of manures.

Black Hamburghs have been black and good—I had cut all the best before I thought of sending; the shoulder piece (see No. 3) will give you an idea of what they were; not bad, I think. Gardeners who have tasted them have admired the flavour much. For the first time I had no difficulty in colouring the fruit, yet the crop was good.

Now I come to Alicante grafted on Buckland Sweetwater—a really good result (see No. 1); over-thinned you may perhaps think, but not for my purpose. Such a piece as I send would keep till April, without doubt. A word from you on the flavour will oblige. This variety is equally good on the Black Hamburgh stock. I have plenty of good rods so growing, but seeds are wanting in the Grapes as in the others.

Gros Maroc on Buckland Sweetwater will, I think, bear examination; for crop, size of berries, colour, and flavour I have seen nothing to touch it. I do not yet know how the stones are, but, as you will see by the sample (No. 2) the berries are very sound and noble-looking. The sample (No. 6) is of the same variety from a Vine on its own roots bearing a very heavy crop in a cold house. The berries are smaller than the others, but much longer. I think the difference in shape remarkable. Very little heat has been used in this house, which has much to do with the condition of the last sample (No. 7) of Alicante, not fertilised, and only the very smallest berries cut out, and those left are nearly seedless. I wish you particularly to note this sample, as the Alicante is generally supposed to be so free in setting.

This year I have had several bunches of Grapes sent to me for inspection, including a sample from the great Manresa Vine, and while this was the best of all the Black Hamburghs, only a few berries had four seeds in them. I wish Grape growers generally would give their experience on the subject of the seeds in Grapes influencing the size and keeping of the fruit. There may be some who do not admit the proposition, but I am of opinion a Grape is

No. 2040.—VOL. LXXVII., OLD SERIES.

not perfect as a fruit when short of the proper number of stones. I have seen Lady Downe's this year quite worthless because, as I considered, practically seedless.

I have made a special point of fertilisation, and shudder to think what the crops would have been without it. One bunch of Muscats hanging "tells a tale." I touched the top portion of the bunch, down one side, and also the bottom, with pollen; where it was not touched all the berries are small, and the effect very striking. Yet the large berries want more stones; and if I did not know it before I know now, that, beneficial as fertilising is, it will not of itself produce seeds in Grapes. Remembering the grand results achieved by Mr. Taylor from the very free use of lime in perfecting stones in his Grapes, I am utterly at a loss to know why my apparently healthy Vines should not, when the same means are applied, answer to my call. I have used a stone (14 lbs.) of lime to a square yard in some cases, and even more coprolites and gypsum. I should like to know what more can be done to effect the desired object. As to the time of applying lime, I have given it three times a year, never top-dressing or mulching without using it. When making the borders I may have depended too much on old mortar rubbish, which is good for a mechanical purpose, and it is possible if more active lime had been used I should have better results; but the point is a moot one, and I leave it for further consideration. Reverting to artificial fertilisation, I cannot help feeling vexed to hear clever men, who happen to catch me dusting the bunches, remark they never have any trouble in setting their Grapes, but "just tap the Vine, and all is right." I wish I had this magician's wand.

My prospects for the next season are good. The wood is extra well ripened and strong—*i. e.*, stronger than that of last year. As the fruit is cut a good sprinkling of lime will be given, washing it well in, following at the spring top-dressing with a heavier dose; the soil being naturally tenacious, will do with more than some of a friable nature.

The question was very gently put to me once this summer—Did I think the Muscats had as much fire heat as they wanted at flowering time? To this I replied, "Supposing they did not, surely the want of fire did not injuriously affect the black Grapes," yet all are alike faulty in stoning. I am fully aware there are faulty bunches, in one house especially, but I think other crops counterbalance this, and believe that more than one good reader of Journal will bear me out in this opinion.—STEPHEN CASTLE, *West Lynn.*

[Our correspondent gives his experience on a subject of considerable importance; and it is observable that he does not hesitate to admit the faultiness of some of his crops, not dwelling on those alone that are meritorious. Mr. Stephen Castle sent us samples of Grapes on a previous occasion, and we could not fail to notice that the skins were lacking in texture, as well as the seeds being few. The condition was attributed to overcropping, or a deficiency of lime, or both. The overcropping is now admitted, and lime has been liberally used. There is a distinct improvement in the samples, the skins being thicker and colour better, and the seeds in the larger berries more numerous, but the smaller are very defective in this respect.

A close examination of the berries sent, the whole of them having been dissected, reveals the influence that the seeds exert on the size of the fruit, apart from its keeping. As a rule, the size of the berries was in pro-

portion to the number and character of the seeds in them, the exceptions to this being so few as to have practically no modifying effect. There can be no seeds without fertilisation, and those thus formed cannot be developed in the absence of lime, potash, and phosphoric acid, of which they are mainly composed, these comprising more than 80 per cent. of their constituents. Mr. S. Castle has evidently applied sufficient lime, and possibly more than enough, in which case the border would be the poorer and the Vines the losers, for if more food is liberated than they can appropriate it is washed away and lost. Has he applied sufficient potash? Well-developed stones contain about 5 per cent. more lime than potash; but if we add the skins thereto we find a great excess of potash in the composition. We are of opinion, however, that the want of seeds in this case is mainly the result of defective fertilisation.

It is quite true that many gardeners have no need to exercise the care that Mr. Castle bestows in the setting of the fruit. This we suspect indicates a difference in temperature or atmospheric conditions during the flowering period. The reluctance of our correspondent to use the front ventilators, which we know are often seriously abused, suggests the possibility of the atmosphere being too damp, according to the temperature, at a critical time. The fruit will set in a low temperature if the air be dry, but not otherwise, and the higher the temperature the drier the air as a rule, when other routine conditions are alike in the two cases. The position of the vineries being low, and the sea not far distant, a naturally moist atmosphere may prevail, and if this is so the corrective that occurs is more fire heat when the Vines are flowering. We have had Grapes set freely at a temperature of 50° in a dry house and district, but found an increase of 15° under opposite conditions distinctly advantageous. Further comment on the subject is left to others, and we now briefly indicate the character of the samples before us.

Gros Colman, fertilised with Black Hamburgh pollen: the largest berry 1 $\frac{1}{8}$  in diameter, contained four good seeds; the majority, nearly as large, two and three seeds, a few smaller berries one seed; colour very good, and quality above the average. Muscat: the largest and roundest berry was the only one having three seeds, the majority two seeds, every small berry one only; size below average, but the firmness remarkable, and quality excellent. Gros Maroc on own roots in a cool house: berries oval, much more so than the Muscats; medium size, well coloured; the largest two seeds, the majority one; quality inferior—soft and watery, the result probably of low temperature and overcropping. Gros Maroc on Black Hamburgh stock: a remarkable change. One berry only, the largest, had four seeds; the majority, 1 $\frac{1}{8}$  inch in diameter, two and three; the smallest only one stone. Berries quite round, and exactly resembling Gros Colman; colour good, and quality far superior to the other. Judging from appearance alone nine out of ten gardeners would have pronounced it Gros Colman, but the palate test settled its identity as Gros Maroc. Black Hamburgh: below average in size; seeds as a rule imperfect, only one berry having four, the majority two, the smallest one; stems weak; footstalks long and slender; colour good, and quality above the average. Judging by the sample alone the Vine is not in a satisfactory condition. Black Alicante on Buckland Sweetwater: berries round and well coloured, medium size, and of fair quality; a few of the largest contained three seeds, the majority two, but several only one. The same variety not fertilised: small, loose, nearly seedless, and practically worthless.



The descriptions are as exact as we can present them, and the results of the examination interesting and suggestive. Mr. Castle grows Buckland Sweetwater well, but he has not stated whether it forms seeds freely or not. We have often seen large berries of it defective in that respect. Much more might be said on the setting, stoning, and swelling of Grapes, and the subject is left for the consideration of cultivators.]

### HELLEBORES.

FROM the middle of November, and even earlier than this, when the giant of its race, *H. altifolius* (*maximus*) commences to flower, onward to the end of February, Helleboré flowers may be had in profusion. It is no wonder, then, that they rank among the choicer flowers of the market at this time of the year. It was not of their value in a cut state, nor yet their beauty in the garden generally, that I wish to say a few words, but to give a few brief observations as to the best season for planting them. The question is a vexed one, and one which is not easily settled. The old rule—viz., “divide the roots immediately after flowering and transplant them,” does not hold good in the case of the varieties of Hellebores, for at this time they will have made many of their new roots, which it is of the utmost importance should be retained, and this can hardly be the case if planting is done late in the season, or what will be more readily understood, after they have ceased flowering. Whatever may be the right time for planting these favourite flowers, I doubt not but that many have this year discovered the wrong time. One of the surest as well as one of the most general signs of the varieties of *Helleborus niger* being unhappy is the absence of their foliage in summer time, the loss of which is due in a great measure to the new roots having been made and the planting done some three or four months after. The primary points for consideration, then, are these, that the planting be done at a season when the newly forming roots may be preserved and the foliage retained intact.

I have been watching these Christmas Roses for some years, and have noted some of their habits. The result of my observations, as applied to the proper season for planting them, is that this should be done during October, or even at the end of September. My reasons are these. Towards the end of September the varieties of *H. niger* begin to emit new roots, which is continued throughout October and November, and it is this particular set of roots which all who court success should endeavour to preserve. These early autumn roots I place much faith in; they are those large fleshy roots which are in healthy clumps emitted so freely direct from the rhizome which continue to grow for several weeks. In good soil they go down to a depth of 2½ feet. Soon after the flowering is complete, which will vary according to the varieties, the young leaves commence to push forth, and simultaneously with these begins the formation of a complete mass of small fibrous roots, the value of which can hardly be over-estimated. Therefore to pursue planting at such a time cannot but endanger the larger roots, and at the same time inflict an irreparable check on the smaller fibres which will take a season to recover. Too often is the loss of these roots followed by the loss of foliage, and if a dry summer like that of 1837 ensues, the plants will have a dry hard time indeed. I have been considerably assisted in these observations by growing them largely in pots, by which I have been enabled to examine the plants from time to time without injuring them.

Some eleven years since, in a garden under my charge, I had occasion to move some large clumps fully 2 feet across, the foliage of which spread out on the lawn, on account of their being planted too near the margin originally, and consequent upon their being moved at a wrong time they lost the whole of their leaves, and pitiable objects they were, notwithstanding that a large ball of earth was taken with them and apparently little harm done to the roots. Luckily it was only necessary to move about three such, so that the remainder, of which there was a score of plants of equal size, had the opportunity of displaying their superiority, and at the same time affording an illustration beyond doubt of their preference for remaining undisturbed. My advice, then, for all Hellebores of the niger section, is to plant at once, and for those who are desirous of lifting old clumps for the decoration of the greenhouse later on, to lift these and pot without delay, as by so doing the great majority of their roots will be saved. In the open ground it is almost impossible to provide them with a soil too deep or too rich, and once planted, allow them to remain for years undisturbed, when, if all is well, you will annually be repaid by numbers of their useful flowers; and if you can assist old established clumps with liberal supplies of liquid manure during the

summer time, it will all add to their vigour both in foliage and flowers.

Of the varieties of *H. orientalis* and others, which constitute the Lenten Roses, I will not speak in detail. These may be planted now with equal success as the forms of *H. niger*, and any new planting should be made at once. In this particular they are not so fastidious, and may safely be planted any time from now till March, and I have planted them after flowering is complete, though I do not recommend its general adoption, since you entail the risk of losing much of the then current foliage, and which add considerably to their general beauty and picturesque bearing.—J. H. E.

### MELONS IN 1837.

THIS year I grew in frames Melons A. F. Barron, received from Mr. Gilbert; Marston Park, received from Mr. Iggulden; and two of Mr. Abbey's seedlings, which were sent me as W. Iggulden, but proved to be nothing like so good as that useful Melon, the seed of which I unfortunately lost when moving, and I am sorry to find the raiser (Mr. Abbey) is in the same plight. I also grew Read's Scarlet, a seedling of my own, and Lunefield Hybrid. The results are as under.

A. F. Barron I found rather tender at first, and it evidently requires a good deal of heat. It was with me deeply ribbed, but a friend of mine who grew it in a house had fruit with very slight ribs, and another friend who had it in a frame had only the very slightest sign of ribs. A peculiarity about this Melon is the rapidity with which it turns from a very deep green to yellow when ripening. In twelve hours I saw a fruit turn from deep green to yellow, much to my surprise. The skin is extremely thin, the flesh white and luscious, the flavour delicate, but in the latter quality it is surpassed by Marston Park.

Marston Park, another whiteflesh, seemed at first as if it meant to perish, and I could not induce it to set the fruit, and when it did it was a long time ripening, but I was amply repaid, for the fruits were most delicate in flavour; in fact, surpassed any Melon in that particular I ever tasted, and no doubt the hot summer contributed to this. The skin is very hard, and this will no doubt prove a good keeper.

The two seedlings which ought to have been W. Iggulden were nothing like so good as the Melon whose name they borrowed.

Lunefield Hybrid, a free setter and beautifully netted scarlet flesh, oval in shape, did not turn out so well as last year, but it is a good Melon.

Read's Scarlet is a first-class Melon for frame culture, and the fruits are extremely handsome, being very round, and the netting everything one could wish. It sets well, is hardy, and the fruits are very heavy. It is full flavoured, and several friends pronounced it the best Melon of all, but I cannot agree with that opinion, although it certainly was by far the most fruitful and useful. After I had cut the last fruit it set another crop, which would have matured had I not required the frame for another purpose. I can strongly recommend it for framework to those who like a scarlet flesh. I may add it keeps fairly well.

Next season, through the kindness of Mr. Abbey, I hope to grow successfully his J. Wright, and if it only equals his W. Iggulden it will indeed be a good one, for I consider the latter the most useful and profitable Melon grown with quality to boot.

Although it was a hot summer I gave no shading, and I attribute the extra quality of the fruit a good deal of this circumstance. To make up for want of shading I gave more air than usual, keeping the lights well up till three o'clock during the hottest part of the summer, and I was rather sparing with the waterpot. Good ventilation is in my opinion the main thing, feeding being a secondary consideration.—H. S. EASTY.

### MILDEW ON ROSES.

MILDEW on Roses this year has been very prevalent in many localities, and, on page 337 your correspondent, “Olton,” asks, “Is dryness at the root a cause?” I have long since pointed out that drought was one of the main causes by which the plants were checked, and thus predisposed to an attack of this destructive disease. Mildew no doubt may be brought into existence by many causes other than the one named—for instance, a wet, cold, saturated soil, the atmosphere in the same condition, poor soil, overfeeding, in fact any cause that would enfeeble the energies of the plant and bring growth to a standstill. Any one of these causes or a combination might result in an attack. It is sometimes difficult to trace the origin of the disease to the right source. In seasons like the past it cannot be attributed to a saturated atmosphere or soil. It might, however, have its origin when the plant is growing in soil of an unfertile nature. If the plants are growing on well drained, deeply worked fertile soil, then in hot dry seasons it may safely and surely be the outcome of an insufficiency of moisture about the roots. I am of opinion that it is more often due to this cause than any other, or

rather the germs of the disease may be first brought into activity and quickly developed with any change in the weather. After it has once started it may only be visible on a few leaves, but has been sufficiently long to scatter its spores on the foliage of many of the plants. This being so a week's damp sunless weather would bring them into life, and the results might not be visible for a short time afterwards. How easy and natural to conclude that the attack was due to the cold damp condition of the atmosphere. I think it may safely be concluded that those plants with feeble constitutions are most likely to suffer. They are most susceptible to the disease, and would be the first to become checked by drought or other causes, while those with strong constitutions with hard leathery foliage generally escape.

It is much easier for those who grow only a few plants to arrest disease on its first appearance, and carry into effect remedies to prevent it when the cause is that of drought. It can be destroyed by syringing, directly it is visible, the whole of the plants with sulphur and water. One good handful or a 3-inch potful may be mixed and stirred into each two gallons of water that may be needed. If done directly it is visible sulphur may be dusted on the affected parts, and if left on for a few days will soon kill the mildew. The whole of the sulphur can afterwards be washed from the foliage with clean water. This is not all, for if the cause has been dryness it will quickly appear again, unless the plants are thoroughly watered and the surface of the soil mulched with manure or other material to prevent evaporation. Mulching on light shallow soils, or to avoid watering, should be done early in the season while the ground is moist. This is the best and most effectual method. In some seasons the mulching would be better off, especially on heavy soils, if the season proves a damp cold one. Next to mulching the soil should be constantly stirred with the hoe, so that there is a good layer of light fine soil on the surface. This is beneficial for light soils, and of greater importance in the case of heavy ones that are liable to crack seriously, and the moisture be evaporated to a greater depth than would rally be the case from light soils, which seldom crack to such an extent as to bring serious consequences. Such methods are altogether useless when the disease arises from the opposite extreme, or a cold saturated atmosphere. The mildew may be kept in check by the use of insecticides, but it is impossible to exterminate it. Although large growers may have the advantage over amateurs and those who grow a few plants by their superior knowledge of their culture and requirements, the latter have also advantages. The suggestions pointed out are not really practicable for large growers; to carry them out to be effectual would entail too great an outlay, which in the present state of trade, and the price for which they are bound to dispose of their plants would leave them without profit. I am, of course, alluding to those who grow for sale. The same holds good to a certain extent with large amateur growers.

Your correspondent further asks for advice respecting the "pruning of Roses now" that have been "badly affected by mildew." The current season's wood may be pruned back to within 18 inches of the starting point. The prunings should be burnt, and the leaves most affected may be removed and destroyed in the same manner. The remainder of the foliage should be carefully gathered up, or it may be picked off in the course of a month and also burnt. Do not fork the leaves beneath the soil, for Nature has provided this pest with a covering that will protect its spores from destruction by rain and frost. The genial weather of May and June will cause the germs to issue forth, which often germinate in the air and finally settle upon any prey that is in a suitable state upon which they can grow and spread.

There is another aspect to this matter, and large growers, especially those who grow for sale, have an advantage over amateurs as well as many professional gardeners. The latter are often so limited for space that the plants occupy the same ground for many years, and frequently are undisturbed. Nurserymen who grow tens of thousands proceed very differently. A change of soil is without doubt as beneficial to the Rose as any other plant, in fact I cannot think it is an exception to an almost general rule. Even if the plants could not be changed to fresh positions they could be lifted at intervals of three years, and the soil well and deeply worked with fresh supplies of manure incorporated, or a little fresh soil, which in many cases would perhaps be preferable. This would do more to keep the soil in a sweet fertile state, and thus assist wonderfully in retaining health and vigour to resist attacks of mildew. There can be no doubt that plants growing in soils that are deeply worked resist the disease much longer, in fact are less liable to be attacked than those growing on shallow soils. The nurserymen have the plants on the same soil for only two years, the stocks are planted on well and deeply worked well drained land as a rule, and the second season afterwards they are disposed of, others being prepared on a different piece of land. How different is this from the system that prevails in not only small but many large gardens. Again, the plants of large growers have always youth and vigour on their side, and thus grow with greater strength and luxuriance than many of the plants to be found in gardens that are old and practically worn out. Solitary plants or small beds are more liable to suffer by drought than the large flats grown by the trade. They are surrounded by drying influences, and suffer proportionally in consequence. When large quantities are grown together the plants shade the ground, and thus they prevent rapid evaporation from the soil. There is greater need when a few only are grown for mulching than when large numbers are grown together and practically cover the ground.—W.M. BARDNEY.

A YEAR or two ago I advocated in the Journal the use of Fir tree oil as a preventive of green fly and mildew on Roses. My experience

since confirms my estimation of it, until now I am almost inclined to think that those who continue to suffer much from these pests either desire, or at least deserve, to do so. I aim at prevention rather than cure; and by the use of Hughes' spray-distributor on Teas under glass, and the syringe or a fine-rosed watering pan in the garden, I find the oil quite satisfactory. I use it about the strength recommended—if anything a little over it. I now seldom use soap and quassia, the other being both cheaper and more readily prepared. Those who have not given the oil a trial should do so, if they desire a preventive, efficacious, easily applied, and pleasant to use. I had occasion lately, after a few weeks' absence, to use it as a remedy with the usual good effect. In repotting my Auriculas I dip them in a somewhat weaker mixture. My plants are too well watched for aphides to get a footing, but the oil seems very distasteful, and I use the spray now and then when the bloom is over. I have seen the mealed foliage a little browned by the mixture when stronger than prescribed in the directions for use. In the case of Roses that are persistently attacked by mildew I agree with Mr. Gilmour that the best treatment is to get rid of them, and I act accordingly. The results from such sorts never repay the trouble they give. This year, Violette Bouyer and Lady Mary Fitzwilliam, the latter both under glass and in the garden, have been with me the most inclined to it. I would be sorry to part with either, and hope they will mend their ways and retain their place. If not, off they go.—A NORTHERN AMATEUR.

### VIOLAS.

I AM sorry to find the subject was not continued last week, but perhaps Mr. Jenkins is waiting for my reply before he contributes anything more. Our subject was the Viola, its properties and classification; but as Mr. Dean has so well defined the show Pansy, I will leave the properties of the Viola also in his able and experienced hands, and give my ideas regarding its classification. The Viola has now become very popular, and during the last few years some fine varieties have been raised, but these again I am convinced will soon be superseded by varieties of finer form, and with markings and edgings as perfect as possible. It is with this object in view that we wish to have Violas classed, and we are inclined to favour Mr. Dean's opinion that the time has arrived for such an arrangement. Mr. Jenkins, in his communication, page 323, defines the characteristics of the Viola, and agrees with us that a line of distinction should be drawn, and solves the problem thus, "Calyx with unequal sepals," a character not allowed in the florist Pansy; but I fail to see how such a description can guide us, for in the order Violaceæ we have in one genus six species, which may be defined in the same way, and I think if Mr. Jenkins were to examine a Pansy he would find the calyx, sepals, stamens, anthers, and capsule very similar to what he has described. But he goes on to say if we rigidly pursue such a course we shall exclude some of our best Violas, and asks how we are to establish such a rule. I answer, in the same way as Mr. Glenn defined the properties of the Rose, the Carnation, or any other flower. We shall exclude none of the fine varieties Mr. Jenkins enumerates, but simply arrange them in two families as suggested by Mr. Dean, page 337—viz., bedding Pansies and Violas. These again I would divide into classes, as follows:—First, bedding Pansies, which would consist of class 1, Sells, where Archie Grant would find a place; class 2, Picotee edged, including Merchiston Castle; class 3, feathered or clouded varieties, comprising Mrs. Baxter. I have chosen these popular varieties as examples in their respective classes, and which I consider bedding Pansies. Of course we shall have all the colours represented in each class; for instance class 1 will be formed of purple, white, yellow, or any other coloured self; class 2 in the same way, only the Picotee edge must be bright and well defined; the same in class 3. Violas I would arrange in the same order—viz., class 1, self, in which Pilgrimage or Bullion would form an example; class 2, Picotee edged, where Skylark or Goldfinch would be represented; class 3, feathered or flaked varieties, including Sejour or some of our new varieties.

The preceding remarks are only our own opinion, and are open to criticism. I know there are many who will not agree with them, but we shall be pleased to learn their opinions through the Journal. For instance, in the two recent communications Mr. Jenkins and Mr. Dean are not quite agreed. Mr. Jenkins would like to retain Archie Grant among the Violas, while Mr. Dean would give it a place amongst the bedding Pansies, and also thinks it a fit companion for Bronze Queen, Lady Diana, or Mrs. Baxter, but these minor points I feel sure will soon be overcome. Now, with regard to the exhibition table. We must ask the secretaries of the different Pansy societies to help us, and give a special or extra prize for bedding Pansies, independent of their prizes for Violas. Such a prize would greatly facilitate keeping the two families separate, for I think nothing seems more absurd (from a florist's point of view) than to see a stand of Violas containing two or three bunches of bedding Pansies. Why not introduce a bunch, or two of Viola odorata as well? Botanically speaking, they would be quite as much in place. Again, I wonder what some of the judges would say to a stand of H.P. Roses with one or two China or Hybrid Tea blooms in it. I fancy they would pass it, and give an inferior stand of H.P. the first place. I would enforce the same rule with Violas.

The object of a classification is to place together those plants which resemble each other in the greatest number of important particulars, and thus to facilitate their study and assist the memory. Two systems have been adopted by different naturalists in their efforts to classify plants. Natural and artificial systems begin with the whole vegetable

kingdom, and divide it into groups, according to some important points of structure. These groups are again divided and sub-divided on a pre-arranged plan until the individual plants are reached. Thus, according to the presence or absence of flowers, vegetables are formed into the two great sections of flowering plants (Phanerogamia) and flowerless plants (Cryptogamia). Each section is divided into sub-kingdoms, each sub-kingdom into classes, and the classes are divided into orders, orders into genera, and genera into species, and some species into varieties. The natural system begins with the individual plants, placing together those which are most closely related in important points of structure, and thus by the repeated grouping of nearly related forms rising at last to a general view of the entire vegetable kingdom. All those plants which agree together in all essential characters, and which appear to have descended from a common stock, are placed together and called a species. All the species which agree together in the essential characters of their flowers or reproductive organs are collected into a genus. We would still like to have the opinion of some more of our experienced florists on the subject. Cannot Mr. James Grieve help us? We have no better judge, and few have done more than Mr. Grieve to raise the *Viola* to its present high position.—G. STEEL.

## MEMORIES OF A TOUR.

### CARDIFF AND ITS GARDENS.

FIVE minutes under the roof of Mr. Pettigrew, the Marquis of Bute's trusted gardener, sufficed to make us feel quite at home. With Mrs. Pettigrew and Mrs. Tourist it appeared to be a case of "love at first sight," and as to her "gude man," his geniality is proverbial to all who know him. Though darkness deepened long before the discussion on sundry matters ended, we could not retire without a look round the garden, or rather "the houses," and with the necessary lantern for our guide we sallied forth at a time that we had been taught years ago all good people should be in bed. Many a midnight hour have I spent happily in exploring glass ranges with a guttering candle. We can look at plants leisurely then, and individually, for we cannot see many at once, while those under the light appear to look better and brighter in contrast with the dark veil beyond; and if we alight on a slug or a cockroach, it is hooked with the glee of the sportsman who "plays" his salmon to the bank. We passed through the different ranges, fumigating as we went along; but at each pause to examine something more closely, the voice of the chief chimed in, "We will see it better in the morning." It is not always so, for I have often noticed that a candle-light view seems to heighten in effect that which is good, and throws a mask over that which is comparatively inferior. We found no slugs or any such "game," but peered among the Melons and the Pines, gauged the merits of the plants, and climbed up to the Grapes, still to the same refrain, "We will see them better in the morning;" and so, in the small hours we prepared for rest, perhaps not feeling ourselves much worse than those very good people who had gone some time before us. Our best friends, however, waited with exemplary patience, and hoped we had had a good "crack."

The morning opened brightly after the rain; the air was sweet, and the lawn a bright emerald green, like spring. But we could see no Castle. The gardens seemed somehow mixed up in the town, for we could see houses on two sides of them, and a highway on a third; over this road and behind the trees on the slopes of the moat the historical building was hidden—forming a boundary, so to say, of another part of the town, only a narrow sunken garden, bounded by a low wall over which loungers can lean, separating the great pile from the street. But we are on the garden side of the highway, and have to see what is to be seen there by daylight.

Mr. Pettigrew's residence overlooks a lawn of two or three acres. It is like a villa in its own pleasure grounds. The first thing to arrest attention was a great clump of the New Zealand Flax, *Phormium tenax variegatum*, in the shrubby border. This and other such clumps have been established for years and are not protected in winter. The bottom or older leaves are cut off, torn into strips as fine as is desired, and used forthwith for tying, instead of harsh dry bast. The fresh strands are soft, tough, and admirable for the purpose. And here a rather curious fact may be recorded. It is this. Only the variegated form of the plant survives the winter, the green species succumbing. If variegation, as some think, is an indication of weakness and the expression of disease, how is it, to speak paradoxically, that the "weak" lives while the "strong" is killed by cold? The problem is delegated to some of the thinkers of the Journal wherewith to exercise their mental powers in finding a solution.

On the lawn are large beds, not all of them filled with tender plants. In one we remember a fine collection of tree Paeonies that must be grand in their season, edged with a broad margin of white Pinks, compact and agreeable by its neatness, while practically keeping itself in order. Another bed is filled with choice Roses, producing growths that presage prize blooms, such as the plants have often produced. Then we find beds of Hydrangeas, the mention of which calls to memory some specimens at another place, over which we caught Mr. Watson, of Kew, raising his hands in astonishment; but of those more anon; we have not yet done with Cardiff. There are beds of Brompton Stocks on Mr. Pettigrew's lawn—sturdy plants that we should like to see next June; also, there is a large bed of a plant we had not seen massed before, forming a sheet of white that puzzled at a distance, but on nearer approach asserted itself as *Achillea Ptarmica flore pleno*, with the largest

rosette-like blooms we had seen—the effects of cultivation, or deep rich soil. Thus large beds on lawns can be effectively filled with other than tender plants, and we suspect are here filled with a purpose. The Castle is a huge building, and small handfuls of flowers and dainty "table" plants are lost in it; to be "seen" flowers must be sent in by armfuls, and these beds will afford them, and the decorative plants must be exhibition specimens, and these too are provided. On the margin of the lawn are bees, in the management of which Mr. Pettigrew proves himself worthy of the name he bears, though he is not of the family of the "old Pettigrew" of world-wide fame, who not only kept bees but made his bees keep him. At Cardiff 100 lbs. of honey in sections are taken from a hive, which is not bad work for a gardener with a wide range of duties far outside the garden walls. On the cottage just one plant was mentioned—the variegated form of *Rhynchospermum jasminoides*, that has been there for years without being covered, and flowers most profusely. A variegated plant again that ought to be tender according to some philosophers, yet there it is, growing against the chimney back, which no doubt helps it, though it must have been frozen over and over again when 15° to 20° of frost were registered in the garden.

And now we enter the kitchen garden. The town buildings are close to the main wall; one of them, a hideous barn-like structure, jutting against it, and made more ugly in contrast with a romantic looking ivy-covered ruin, a monastic relic, perhaps, on the opposite side. This garden may fairly be called a town garden, and it will be proclaimed the best town garden in the kingdom till another is found surpassing it in general all round excellence indoors and out; indeed it would run a close race with most of the best country gardens in those respects. The soil is good, and by intelligent deep culture has been made wonderfully fertile; and it may be safely said it could not have been rendered equally productive by any other means. The glass structures are good, commodious, well designed, well ventilated, and well built. Under these circumstances it may be asked, What drawback can there be as placing the garden at a disadvantage against real country gardens? This, the prevalence of red spider. No one who has not had the charge of gardens in or near large towns can fully appreciate the persistency of the attacks of this destructive pest, and the difficulty of combating it. It is bad enough in some country districts, no doubt, but, as a rule, very much worse where the breezes cannot play freely in a long refreshing sweep over vegetation in summer. The subject can be made clear by an illustration. Plant some Violets close to a south wall, and before there has been a month of hot weather they will be "eaten up with spider," the dry air rebounding from the wall being exactly suited to the well-being of the pest, which multiplies accordingly; then go to a hedgerow or bank in an open field, and though the soil may be much less rich than in the garden, the leaves of the Violets will be fresh and green. The air coming in contact with buildings is deprived of its moisture to a far greater extent than when passing over cornfields and pastures. In touching on this subject, memory takes me back to a time when I had to grow Violets somewhat extensively. Some were planted near a wall facing south, with the idea that in such a warm sheltered place the plants would afford flowers in the winter; others were grown on the south side of a hedge of espalier fruit trees. Those near the wall were a complete failure; those sheltered by the trees, yet with a current of air passing through them and over the plants, a great success. This little Violet test shows the difference in town and country gardens as affected by the insects in question.

In the town-sheltered garden under notice the pest abounds greatly in summer. The row of Elms on the "country" side of the walled enclosure get red with it; the leaves of Apple trees are drained of their juices, but Pears escape with comparative immunity. How is that? Is it not because the cuticle of the leaves is harder, hence more resisting, and the insects attack the softer and thinner leaves of the Apple? Do not they proceed on the same lines in vinerias, attacking the laterals and thin flimsy leaves first, leaving those that are stout and "leathery" till the last when the others are drained of their juices? If that is so, and I believe it is, the moral is clear—namely, the stouter, hence better, the leaves the less vulnerable they are to the attacks of the enemy. The best preventive of insects is good culture and good management.

Pines, Grapes, Peaches, Melons, Cucumbers, and plants are grown well at Cardiff, but all have to be shaded more or less in the summer to aid in keeping the ubiquitous foe at bay. Syringing, damping, and care in ventilating do not suffice, nor would the shading were it not conducted with judgment—not used in excess, and when not wanted, nor if vigorous growth were not induced. Dark, firm-leaved Pines, with their massive fruit—one a Jamaica Queen, if I remember rightly—15 or 16 pip deep, show that shading has not hurt them; a grand house of Alicante Grapes, with hard, short-jointed wood, stout dark foliage, and a crowded crop of well-finished fruit, gives the same assurance, as does the Peach house, 60 feet long or more, occupied with four splendid trees; and it is the same with Melons and Cucumbers, that bear continuously throughout the season, the latter watered to the last like the former, and the flavour of the best. Shading, as it is understood and practised by some persons, would ruin all those crops, but as applied at Cardiff they are benefited. If I were asked to what extent the shading is conducted, I should answer, without knowing, just enough for mastering the red spider, and no more; and as to the material employed, I should say, brains. If further particulars are wanted, Mr. Pettigrew must be good enough to supply them. I cannot; for I either forgot to ask, or forget if I were told; but I hear that friend Iggulden arrived, tantalisingly, the day I left, and perhaps he knows, so I leave him to put me right



where he conceives I am wrong, and trust he will not find the exercise uncongential.

The early Grapes were cut, the Vines being in the same excellent condition as to sturdiness and firmness of laterals as those bearing so heavily. In a lean-to range vigorous young Vines are covering the roof, some of the Gros Colmans bearing medium bunches of splendid berries beautifully finished. The borders were bedded down with clean straw to prevent the moisture rising, too much of it not being good for late Grapes; for the principle of osmosis is a great fact, its existence and action only being denied by persons who do not understand it. Under these Vines were some very fine Ferns, chiefly *Adiantum farleyense*, and the moisture from them was sufficient for the Vines in that stage without evaporation from the border. It may be said that all the inside Vine borders were thickly covered with littery manure, dry on the top where the Grapes were ripe or the crop removed, but damp below. The borders are as firm as Mushroom beds, and sixteen-stone men like Mr. Pettigrew and his visitor could jump on them without making any marked impression. On "poking" through the mulching, the soil was found distinctly moist, and permeated with a bristling mass of active fibrous roots. Here, then, was the secret of the short-jointed wood and well finished, though, at the first glance, too heavy crop of Alicantes. Those roots are the finishers of Grapes and the supporters of foliage, but they could not have been in anything approaching such numbers in a light, loose, dry-surfaced border. Each Vine carries several rods, some more than others, and if there is any difference, the greater the number of rods from a stem the better the crop. It were easy to say the rods were too close, from 2 to 3 feet apart, but the great crop of fine bunches and berries enforced silence. Spur-pruning is adopted, and Vines in the condition of these will endure it to any extent, and to depart from the method would not be a change in the right direction.

It is the back wall of one of the lean-to vineries that is covered with Lemons, three trees furnishing in the most complete and satisfactory manner a wall 30 feet by 10 feet. Only once have I seen the wall of a vinery covered so satisfactorily, and that was with white Camellias, the value of the blooms equalling that of a good crop of Grapes under the roof. But Lemons cover a wall much more quickly, the bright green leaves are attractive always, the blossoms must emit delicious perfume in their season, and the large juicy fruit succeeding are highly ornamental and at the same time useful, those on the wall in question being quite above the average of imported "shop fruit." It is of little use visiting gardens without picking up hints that may be useful or suggestive, and the method of Lemon culture at Cardiff is recorded as showing how the back walls of vineries may be covered effectively.

To the best of my recollection three span-roofed houses are devoted to plants, two of them 60 feet long, about 22 feet wide, and perhaps 20 feet high to the ridge, the other house being larger. One of them was mainly occupied with Fuchsias—decorative plants for the Castle—huge bushes in 10-inch pots, not plants pinched and tight-laced, and made artificially prim, but represented in their natural freedom and gracefulness. They must have been very handsome when in their prime. Not many varieties are grown, but several plants of a few that are most suitable for the purpose for which they are required. Mr. Pettigrew does not waste much time in pinching and restricting either plants or trees and moulding them into fanciful shapes, but allows them as far as is practicable to assume their natural habits. *Aralia Veitchi* is grown 10 feet high, the leaflets usually slender, being 1½ inch or more in diameter—trees rather than plants. In one of the stoves *Eucharis* luxuriate, and suspended from the roof is a noticeable plant of *Æschynanthus Lobbianus*. It is in a basket, its healthy growths hanging down about 4 feet, and when covered with orange scarlet flowers must be a beautiful object. Prominent in the larger stove is one of the best specimens in the kingdom of the yellow-stemmed Palm *Areca lutescens*, a splendid example of *Encephalartos villosus*, many large freely grown and brilliant *Crotons*, with other kinds that need not be enumerated, and as regards their quality it is enough to say that Mr. Cypher's had to stand second to them when placed in competition. Plants are, however, not grown for exhibition at Cardiff, but local shows are encouraged with what "happens to be worth taking" at the time of their occurrence; and it is very certain they would have to "happen" at a peculiar time when something could not be found for enriching them. Outside we found a few hundreds of *Chrysanthemums*, large, well-grown bushes that would yield a wealth of blooms; but plants of various kinds must be left for jotting down a remembrance of fruit trees.

Whatever may be forgotten, no one who visits the walled garden of about four acres, and another splendid kitchen garden, apparently a good deal larger, will be likely to forget the pyramid Pears at Cardiff. Apples and other fruits are grown as well as we could desire to see them, but the Pears are magnificent. No such mistake has been made as planting a tree each of all the varieties to be found in a catalogue, and pinching and root-pruning them into a lot of pomological dolls, but the sides of the different quarters have been each occupied with half a dozen trees of a sort. They were planted as maidens, and for years pruning has been limited to the thinning out of a few branches to prevent overcrowding. More perfect and handsome trees could with difficulty be found, and in all my travels I have not seen any of their age to equal them. Several are 25 feet high, forming grand avenues, and must bear tons of fruit of the first size and quality, for the ground was trenched for them and made good to the depth of 2 or 3 feet. The thinly disposed branches that grow as much as they like or can, and not being shortened, form natural spurs their entire length, are "roped" with fruit, and roped, too, to prevent it breaking down the branches, for

long poles are inserted round, and the trees of Pitmaston Duchess particularly, laced with wagon ropes. These rows of such Pears as the one just named, *Jargonelle*, *Beurré d'Amanlis*, *Beurré Diel*, *Marie Louise*, *Louise Bonne de Jersey*, *Bergamotte Esperen*, and others of sterling usefulness, were worth going to Wales to see. The first and last mentioned were, perhaps, the more striking, and will dwell in the memory as triumphs of high culture, and as witnesses of the usefulness of the Pear stock that will bear all the examination and cross examination that can be levelled against them and it. Quince stocks and Paradise stocks have been tried at Cardiff, and answer well enough for a time, but eventually trees on free stocks assert their supremacy in prolonged vigour and productiveness.

The walls are covered with trees, well trained, healthy, and fruitful, the Pears there also on the free stock, and in greater variety than in the open; the walls are covered with stone copings, projecting about 9 inches, and the ground is not cropped nearer than 4 feet from the stems, but there mulched. The borders are probably narrower 30 than 25 wide, so there is plenty of room for vegetables, which are grown in abundance, without cropping close to the walls. Young Peach trees of the best sorts have been planted where they are likely to prosper, and the Tomatoes between them would bear the inspection of the author of the useful treatise on this popular fruit. How far a fine round local variety is distinct from existing sorts I will leave him to determine; another, a chance seedling, was remarkable for its huge clusters, but, on reflection I do not think is sufficiently distinct from King Humbert or Chiswick Red, and Mr. Pettigrew will have to try again, and perhaps wait a long time before he produces something as worthy of the place as the Cardiff Castle Cucumber. The mention of the town and the Castle reminds me I have said nothing about either of them; but I had two days to look round, and have only jotted down a few memories of one of them; those of the other must wait.—A TOURIST.

P.S.—Two misprints occurred in my article on page 361, last week. The word "impression" in the fourth paragraph ought to have been "impressing," and the word "anything" in the fifth, was written everything.—A. T.

## GLADIOLUS NOTES.

THE present has been the best season for *Gladiolus* that we have experienced for many years. The plants made a strong growth, the spikes of blooms being correspondingly large, and the earliest ripened sorts which we have just been lifting have fine corms. As exhibiting the difference of seasons, it may be stated that in 1886 our principal blooms were not out until the middle and end of September, whereas in the present year we had a continuous show from about the 10th of August until the end of September, the earlier spikes opening in July, and there are still a few late ones to open. Owing to the very unsatisfactory flowering last year, an old-fashioned plan was resorted to in spring in order if possible to secure a better and an earlier season. In order to err on the safe side, we have also further grown many more of the earlier varieties, which, if not so rich in bright colours as the late flowering sorts, have the advantage in yielding spikes in a cold season, whereas the late varieties do not.

The plan referred to was one that was very common when the *Gladiolus* first began to be grown as a popular flower, and that was to start the corms well into growth before planting them out. As we had a very large number to prepare and not much room for the purpose, the corms were simply set out closely together in boxes on a layer of leaf mould, the corms covered with moss and then set on the inside border of a vinery. This was done about the end of March. The growths started immediately, roots being freely formed at the same time. When the top growth was 2 inches long the boxes were removed out of doors, sheltered from sun and cold for a few days and nights by means of mats thrown on the top of the moss. They were planted out about the 10th of April, the roots at that time being 3 inches in length, and were lifted out of the leaf soil without any breakages. The tops were not longer than 3 inches and were covered in planting. A little leaf soil was placed under and over the roots. During the summer drought the plants were watered and had three or four surface dressings of manure, which helped them greatly. The best of our spikes for the last few years have been produced by imported French corms. Next year, if the season is anything like as warm as that just ended, our home-grown corms will be quite as good as the French ones. We have also secured some well-ripened seeds from a few of the best kinds, a thing that has been impossible here for several years back.

As catalogues give no indication of the earliness or lateness of the varieties, I append a list of good early sorts, as well as those which are later in flowering. Early varieties.—*Ambroise Verschaffelt*, deep rose, sometimes fine; *Amitié*, a mixture of carnation, soft yellow, and purple, very beautiful, new in 1884; *André Leroy*, cherry and white; *Antiope*, orange cerise, long spike; *Archduchesse Marie Christine*, flowers very large, fleshy white, with marks of rose; *Bicolore*, very distinctly marked salmon, the two under lateral sepals pure white; *Carnation*, fleshy white and carmine, fine; *Cré-*

puscule, lilacy rose, with stripes of carmine and violet, very fine variety; Dalila, a very telling and good sort, rose; Daubenton, a peculiar shade of rosy lilac; Diamant, not a good show variety, but as fine in its marking and effect as an Orchid, very light; Didon, nearly white, very fine; Gloire de Fontainebleau, carmine rose, white lines in middle of petals, long spike, fine; Hesperide, a beautiful coloured sort, salmony rose on pure white, rather wanting in texture, but fine; Leander, lilac, of a telling shade, very fine; L'Unique Violet, deep violet and carmine, extra fine; Mabel, a very fine sort of the white and carmine shaded class; Ondine, a most lovely white kind with a small violet spot on the lip; Opale, very delicate rose, fine; Orphée, rosy carmine, one of the finest; Pactole, a good yellow; Panorama, lilacy rose, very prettily marked; Penelope, flesh, most useful kind; Pepita, yellow; Psyche, light rose, prettily marked; Shakespeare, white with rose spot, one of the most useful; Sylvie, a very taking light variety; Tamerlane, very dark variety and one of the best; Jacqueminot, a very beautiful sort, orange salmon and scarlet spots and stripes.

Of later flowering varieties Africain, a most distinct kind, slaty brown and scarlet, with lines of white; Aramis, fine, a mixture of rose, cherry, carmine and white; Atlas, long spike and good sort, white and lilac; Benvenuto, very long spike, brilliant orange red, white spot; Camélion, slate, with white lines in middle of the petals; Caprice, very beautiful, fresh rose and white; Dictateur (1886), lilac, carmine and white, fine; Eugène Souchet (1884), a most beautiful kind in the way of Teresita and Orphée, one of the very best; Grand Rouge, scarlet, a most magnificent variety; Horace Vernet, very brilliant red and white spots, a really grand old sort; Jupiter, deep red, and stripes and spots of darkest carmine, fine; Le Vesuve, brilliant red, long spike, very fine; Madame Desportes, an old and beautiful white kind, tender; Matador, red, white lines; Michael Angelo, crimson, extra fine when it does well; M. Ad. Brongniart, rosy orange, very fine and distinct; Murillo, cherry, fine; Octavie, clear rose spots and lines of white, fine; Parmentier, a very lovely deep rose, with carmine and white spots; Phoenix, cherry, fine; Phidias, purple and violet, good; Rayon d'Or, yellow and carmine, very pretty; Titania, salmon, long spike. These late varieties are, as a rule, much richer in the colouring and generally more effective than the earlier ones. Starting the corms as recommended should suit these well where they do not flower and finish their growth naturally.—B.



THE storm, which appears to have raged so furiously in various parts of the country early in the week, was only slightly felt in the metropolitan district, and we have not heard that any material damage was done to buildings, trees, or gardens in or near London.

THE NATIONAL CHRYSANTHEMUM SOCIETY'S GENERAL COMMITTEE held a meeting on Monday last at the "Old Four Swans," Bishopsgate Street, the President, Mr. E. Sanderson, in the chair, and there was a good attendance of members. Several new Fellows and members were elected. The Hon. Sec., Mr. W. Holmes, was empowered to make some necessary arrangements for the forthcoming Show at Westminster. A discussion took place respecting the special prizes, as a continental grower had not forwarded the prize money at the time promised. Assurances were, however, received, that the prizes announced would be duly paid.

THERE is an unusually fine display of PITCHER PLANTS IN MESSRS. J. VEITCH & SONS' NURSERY, CHELSEA, at the present time, and numerous as the "pitchers" have frequently been, we do not remember observing so large a number before. Over 2000 "pitchers" in different stages are borne by the plants in one house, and these represent forty species or varieties, greatly diversified in form and colouring. *Nepenthes Mastersiana* is very handsome, some plants in moderate sized baskets having thirty-three well formed dark coloured pitchers. The peculiarly beautiful *N. Northiana*, *N. bicarata*, the large *N. Rajah*, and *N. Veitchi* at once attract attention. Then there are the old *N. Rafflesiana* and *N. Hookeri*, which retain their pitchers so long; the brightly coloured *N. Morganiae*, the curious green *N. cylindrica*, *N. Chelsoni*, richly mottled; *N. sanguinea*, *N. Wrigleyana*, one of the best of the numerous hybrids; *N. Sédani*, *N. Curtisi*, and many others.

Those who imagine that *Nepenthes* are difficult to grow or not ornamental enough to deserve a place in a stove should see the way in which the Chelsea plants flourish, and the varied character of their markings and colours.

— MESSRS. PERKINS & SONS, Coventry, send a box of FLOWERS, comprising a few samples of what is most in demand now for floral decorations, and conspicuous amongst them were the white and scarlet *Bouvardias*. Especially fine was President Cleveland, the most brilliant scarlet variety yet obtained, and possessing the additional recommendation of compact habit and floriferousness. Pompon *Chrysanthemums* Rose buds, and double Zonal *Pelargoniums* were also included, and a list of the prizes won at exhibitions during the present year for bouquets, buttonholes, &c. It appears from this that seventy-four first prizes have been awarded to Messrs. Perkins & Sons at twenty-six shows.

— THE best of this year's *Chrysanthemums*, flowering in Messrs Davis & Jones' collection, is MR. GARNAR. It is a Japanese variety raised by Delaux. It is a broad shouldered bloom of the "build" of Edouard Audiguier, with roundish twisted florets of the richest yellow imaginable, in this respect being equalled by few and surpassed by none. The plant is a sturdy grower with large foliage, and promises to be an acquisition. The great majority of the new French varieties of this season, now flowering in the same collection, are worthless. Mr. Davis is disgusted with them, as well he may be, and no doubt most of them will be destroyed.

— MR. HENRY DRAKE, Hon. Sec. LEWISHAM AND DISTRICT FLORAL SOCIETY, informs us that at the general quarterly meeting of their Society, on October 26th, Mr. N. Davis (of Messrs. Davis & Jones), *Chrysanthemum* Nurseries, Camberwell, kindly contributed a paper on "Chrysanthemums, our Successes and Failures." It appeared to give general satisfaction to the members, who attended in good numbers to hear advice from so experienced a grower. In a recent issue we stated that the Lewisham *Chrysanthemum* Show was to be held at the Lewisham Town Hall, it should be Lewisham Public Baths.

— GARDENING APPOINTMENT.—Mr. Louis Ware, late foreman to Mr. Norman, Hatfield House, has been appointed head gardener to Baron W. Von Schröder, The Rookery, Nantwich, Cheshire.

— MESSRS. ALFRED PEEL & SONS, horticultural builders, &c., High Street, Wood Green, London, inform us that they have been awarded a first-class medal at the Royal Yorkshire Exhibition, Saltaire, for their Paxton span-roof greenhouses.

— MR. R. P. BROTHERSTON observes:—"DR. HOGG PEAR fruited here this year for the first time. It is of a most delicious flavour, and by far the best in that respect of any early Pear we have. The handsomest autumn Pear is Flemish Beauty or Fondante de Bois of French catalogues. The flavour is not first-rate, but for large autumn parties one can dispense with that so long as there is something fine to look at. It is also a certain and heavy cropper, and a Pear worth growing."

— A CORRESPONDENT writes:—"Permit me to call attention to the exceeding beauty of DOUBLE IVY-LEAF PELARGONIUMS IN WINTER. A large plant of the scarlet Emile Lemoine, which had been placed in a warm house and bloomed there, first showed me the treat we might hope to expect from these. I shall be very much surprised if we do not find the newer sorts, which with finer fuller flowers have a dwarf habit of growth, quite commonly grown as winter-blooming plants. There is no shade in any flowers we have which can compare in softness of colouring with such varieties as Isidore Feral, Madame Thibaut, and Lemoine's Galilee of this year."

— MESSRS. JOHN LAING & Co. send us from Forest Hill a flowering spray of the NASH COURT VARIETY OF LAPAGERIA ROSEA that they are now distributing. The blooms are 4 inches long, not measuring the stalk, and the colour a bright rosy scarlet. It is unquestionably a beautiful variety of a deservedly popular plant.

— A LARGE MARKET GROWING ESTABLISHMENT.—A visitor who has recently inspected the Brothers Rochford's establishments at Broxbourne, Cheshunt, and Tottenham, writes:—"I was quite astonished to see the quantity of Grapes and Tomatoes. Two of the brothers said they each had been sending for some time about three tons of Tomatoes to market a week. One of them has a house that covers over half an acre of ground. It was erected this spring, and planted with Alicante and

Gros Colman. The Vines are planted about 3 feet apart and 6 feet between the rows. They are to be grown on upright wires, and stopped when they reach the roof. It will be interesting to know how that system will answer. Between the Vines are planted Tomatoes, which were bearing enormous crops. One of the brothers alone has fifty-two houses, ranging from 80 to 120 feet long, principally planted with Grapes, Tomatoes, and Cucumbers."

— A LAWN TENNIS GROUND.—"G. W. C." states that "at Canwick Hall, Lincoln, there is a tennis ground made two or three years ago by Mr. William Harris, the gardener. When the soil had been wheeled out to the required depth, the rough stones were placed back again in the bottom to the depth of 9 inches, then about 3 inches depth of coarse cinders was put on, the whole well rolled in, and finished off with 2 inches of binding ashes from a brickyard. It is occasionally rolled, and has a fine even surface. The size is 123 feet by 100 feet. It is so porous that a game may be played a few minutes after a shower, and in the winter by allowing it first to become hard with frost it may be flooded to a depth of 3 inches, which then forms a sheet of ice, and thus makes a safe place for skating. The lawn is extensive, and is sometimes used in addition to the above for tennis courts. There are some splendid specimen trees growing on it, noticeable very fine Cedars, *Picea Pinsapo*, the Weeping Elms and Beech, an enormous dropping Ash, and in the shrubberies around are several grand specimens of *Ailantus glandulosa*."



#### ORCHIDS AT LINCOLN.

EAST CLIFFE HOUSE, the residence of N. Clayton, Esq., has been celebrated for some years in the neighbourhood for the collection of Orchids and other valuable plants grown so successfully by Mr. A. Wipf. Although the new and rarer plants are added the grand old ones are not forgotten, as may be seen in the large healthy specimens of *Cypripedium insigne*, numerous *Cœlogyne cristata*, well flowered pieces of *Lycaste Skinneri*, a plant of which last year bore thirty-two blooms, and which promises to carry as many or more before long. It is surprising that this does not become a more general favourite; few Orchids last longer in perfection. I have known an individual bloom to remain fresh for six months, and some of the varieties are very beautiful.

*Dendrobium nobile* is represented by some good plants, and their season of blooming is extended by hastening some into early growth and retarding others. The lovely *D. Dearei* is flowering freely, one small plant carrying twenty charming white blooms; this, too, remains quite fresh for a long time. *D. infundibulum* close by is an admirable companion to the above. A fine specimen of *Cattleya Aclandiae*, 2½ feet through, must be a sight worth seeing when in bloom. It is grown in a large pot, well drained, and potted in good fibrous peat, with a little fresh sphagnum. *Cymbidium eburneum* is grown well and blooms very freely every season. Of *Odontoglossum Phalenopsis* and of *O. vexillarium* there are some clean healthy plants. *Cypripedium niveum* and *C. Spicerianum* are grown in quantity. The *Phalenopses*, some of which are flowering, look at home. *Aerides Lobbi*, *Saccolabium Blumei majus*, and *S. retusum* are in bloom, the latter having three spikes of waxy white, spotted with pink, flowers. These are only a few of Mr. Wipf's favourites. *Nepenthes* and *Sarracénias* also come in for a large share of attention, and there are many interesting hybrids of the latter rapidly forming good plants.

#### CANWICK HALL.

This is one of the country seats belonging to C. C. Sibthorp, Esq., and although the Orchids are not numerous (for they only occupy part of the plant stove) there is something to give the amateur an idea of what may be grown satisfactorily associated with other plants. The first to command notice is the old but lovely *Oncidium flexuosum*, which is grown in quantity. The plants are in 48-sized pots, the compost being equal parts of good peat and sphagnum moss. The variety is larger than the ordinary form, bright yellow, spotted with brown. Some of the plants were carrying four spikes each, producing abundance of flowers that will last a long time. Another favourite of easy culture is *Odontoglossum grande*. This annually yields a grand display of flowers in the dull autumn days, rendering it doubly valuable to the

owners, who are so fond of flowers, and it has the advantage of remaining a month or more in beauty if the flowers are kept dry. Another plant which is grown remarkably well is the old *Zygopetalum Mackayi*. There are many specimens which flower during the winter months and last a long time in perfection. *Oncidium Papilio*, a fine healthy plant, has not been disturbed from a block that it was placed on ten years ago, and it continues blooming from the old flower stems. This is rooting freely, and during the growing period receives a liberal amount of water. Some *Cattleyas* and *Dendrobiums*, &c., are grown in the same house. The gardening management throughout reflects much credit on the painstaking chief, Mr. W. Harris, who has been in charge for so many years.

#### SUDBROOKE HOLME.

This is another residence of C. C. Sibthorp, Esq., and is about six miles from Lincoln. The gardens are in charge of Mr. George Gray, who is a skilful plant grower and a good all-round gardener. His plants are tastefully arranged. In one house are principally Ferns and Orchids. The iron supports and roof are furnished with light and graceful-growing climbers, such as *Asparagus plumosus*, *Lygodium scandens*, and *Stigmaphyllon ciliatum*, the latter blooming very freely with flowers somewhat resembling an *Oncidium*. Half way between the stages and the floor a long narrow box about 4 inches wide and the same depth runs the entire length. This is filled with *Panicum variegatum*, and adds greatly to the charm of the house. Mr. Gray is a great believer in the free use of guano, and judging from the freshness of his plants he evidently knows how to use it to advantage, although he does not make a practice of administering it direct to his Orchids. *Acropera Loddigesi* in large plants with many pendulous racemes is very interesting. It succeeds best well elevated above the rim of the pot and grown in a warm house. Another plant requiring similar treatment is the old but handsome *Gongora atropurpurea*, for when in flower it is very interesting. *Oncidium ampliatum majus* and *O. incurvum* are well grown, the latter flowering freely. The blooms are small, but are produced freely and remain a long time in perfection. It is useful during the autumn and winter months. *Calanthes* are sending up good stout spikes, which will succeed the *Odontoglossum Alexandrae* and *O. grande* now in bloom. *O. citrosum* is making strong growths, which will make a fine display in the spring, and *Cattleya crispa*, *C. Mossiae*, and *C. Trianae* are likewise promising well for the future; they are all large plants. The fragrant *Lycaste aromatica* in good specimens is much admired. *L. (Maxillaria) Harrisoni* and *L. H. alba* are well worth growing, especially when the plants attain the size of these at Sudbrooke. Other good plants of easy culture are *Brassias*, various sorts of *Epidendrums*, *Cypripediums*, *C. Boxalli* is exceptionally well done, *Stanhopeas*, and *Zygopetalums*. In one of the vineries at rest are some *Dendrobiums*, and in another house are good plants of the pretty *Anæctochilus Dawsonianus*. Many fine species of this genus have been introduced, but some are so difficult to manage that one seldom has the pleasure of seeing a good collection. I believe the most satisfactory manner of growing them is to pot them in peat and sand, with a little fresh sphagnum moss and potsherds broken small and placed on inverted pans or pots in a large pan of water, taking care that the water does not touch the pots containing the plants, the whole being covered with a large bellglass, mounted an inch or two above the water to allow a sufficient amount of air to pass under. The leaves of the one under notice are very attractive, and the flowers, which are white, are very useful for cutting.—G. W. C.

#### INDIAN EXPERIENCES.

(Continued from page 359.)

THE Government botanical garden of the Nilgiris is situated on the slopes of the Dodabetta Mountain at Ootacamund, and, as previously stated, was first laid out by the late Mr. W. G. Melvor in 1848. Since that date it has undergone considerable change and improvement, and is now under the direction of Mr. A. M. Lawson, late professor of botany at Oxford, who was appointed some few years ago director of Government *Chinchona* plantations, parks, and gardens, with Mr. Jamieson, the former superintendent, as curator. The garden, since the time of its first formation, has gradually developed into one of the most beautiful, and, on account of the climate, one of the most enjoyable spots on the face of the globe. Beautiful trees, shrubs, plants, and flowers, collected from many lands, may be seen and studied in their fullest development in the open air all the year round. Originally the site of the gardens was a thickly wooded ravine with a range of altitude of from 200 to 250 feet. Mr. Melvor, with great skill and taste, contrived, by preserving portions of the natural forest and large individual trees, to lay out, by paths, terraces, parterres, and pieces of water, a garden at once beautiful and picturesque, a veritable queen of pleasure grounds. Above and around the garden the slopes of the Dodabetta Mountain are clad with splendid specimens of Australian and Tasmanian trees, including many examples of the Blue Gum and other species of



Eucalyptus, as well as numerous species of *Acacia*, all of which take extremely kindly to the climate of the South Indian hill tracts.

At the entrance gate is a large conservatory, in which is grown tender plants, such as *Begonias*, *Bougainvilleas*, *Orchids*, &c., but no artificial heat is ever used. The director's and curator's houses are situated near the centre of the garden; and there are other glass structures which were built for propagating purposes during the early stages of the *Chinchona* experiment. The garden is entirely worked by coolies from the Mysore and sometimes Chinamen, with East Indian overseers. The only portion of ground in the garden that may be called flat is situated near the entrance, and this is occupied with lawns, ponds, and flower beds, together with many fine specimens of coniferous and other ornamental trees and shrubs. This is the only portion of the grounds that suffers from frosts during the winter months. Hoar frosts may frequently be seen here in the early morning, while the upland slopes escape altogether. Many of the pieces of water contain miniature islands planted with grand specimens of *Pampas Grass* and *Arundo conspicua*, both of which yield at Ootacamund larger and finer spikes of flower than any I have ever seen in England. Around the edges of these ponds may be seen, with their roots reaching far into the water, luxuriant plants of the *Lily of the Nile* (*Richardia aethiopica*) with their perennial display of white blossoms. Fish, consisting of rudd, lake trout, tench, carp, gold and silver fish, &c., were introduced into these ornamental ponds about the year 1869. Since that date quantities of these fish have found their way from the garden ponds to the Ootacamund lake and to many streams on the Nilgiris. To the late Mr. McIvor and to Dr. Day must be accorded the credit of having introduced European fish to the waters of the Nilgiris.

The first terrace is laid out in flower beds in the Italian style, with a very ornamental band stand in the centre. This portion of the grounds is a favourite promenade for the public. Rising from this in successive terraces and winding paths the top of the garden is reached, from which a magnificent view of the whole station of Ootacamund is obtained, with its beautiful lake in the centre, and picturesque houses on every hill. Throughout the whole station the Australian *Eucalyptus* and *Acacia* are planted in abundance, giving a somewhat sombre and churchyard appearance, but this is somewhat compensated for during the months of July and August by the glorious display of the yellow blossoms of the *Wattle Tree* (*Acacia dealbata*). During these months the appearance of these trees is truly magnificent.

The paths and walks of the garden are mostly hedged with such plants as *Fuchsias*, *Heliotrope*, *Roses*, &c., and all yielding an abundance of blossoms all the year round, such plants as *Roses* and *Heliotrope* being wonderfully fragrant. Large and magnificent plants of *Brugmansia sanguinea* and *suaveolens* are continually met with on the steep grassy slopes, clad in their huge pendant blooms, which at nightfall throw off their peculiarly agreeable fragrance. Branches of these plants roughly lopped off and stuck into the ground, will as quickly form plants in this climate as *Willows* do in England. Grassy banks covered with *Hydrangeas* covered with bloom may also be seen, which are perfectly wonderful to behold. The flowers are usually of a very deep blue tinge, 'tis said from the presence of iron in the soil. French spotted and large-flowered *Pelargoniums* bloom admirably when planted out permanently on the sloping banks, and required no other treatment save a yearly pruning. I have seen banks of these plants covered with immense trusses of bloom and lasting for many months in the rarest beauty. In one particular recess towards the top of the garden there used to grow and bloom freely a clump of *Camellias* of various colours, and climbing up, and growing in the surrounding trees and borders, and flowering luxuriantly withal, such plants as *Clianthus Dampieri*, *Habrothamnus*, *Tacsonia*, *Mandevilla suaveolens*, *Kennedya*, *Chorozema*, *Begonia fuchsoides*, *Azaleas*, *Aloysia citriodora* (huge trees), *Aralias*, and scores of others.

A very beautiful fernery exists near the top of the garden, which is very tastefully arranged and planted with numerous *Ferns* indigenous to the hills as well as from other countries. Although the Ootacamund botanical garden contained a most extensive and very rich and interesting collection of plants brought together from all parts of the world, no attempt—at least up to the year 1877—was ever made at scientific arrangement, which was always a matter of deep regret. No better locality on the face of the globe could be found than Ootacamund for a garden of instruction in the true sense of the word, and where expensive glass structures are not necessary for the bulk of the plants grown. Matters have no doubt improved since the advent of the present Botanical Director, Mr. Lawson, who, no doubt in time—should he be allowed the necessary means—will make the gardens at Ootacamund worthy to be classed with the best botanical institutions of the world.

In closing these articles I have only a few words more to say with regard to the general appearance and climate of these beautiful hills. The first visit of those who have been for some time located on the hot and arid plains of Madras is delightful and exhilarating to the last degree. The visitor as he begins the ascent of either of the Ghauts leading from the plains, is not prepared for the wonders that are gradually revealed to his gaze as he ascends mile after mile of the winding mountain road. Leaving the steamy and hot village at the foot of the Coonoor Ghaut, with its acres of graceful *Cocunut* and *Areca Palms*, the traveller gradually mounts into a region where the rich tropical vegetation gives place to a more stunted form of growth. From the splendid forms of the *Palms* at the foot to the region of *Cinnamon*, *Cloves*, *Guava*, *Loquat*, *Mangosteen*, *Nutmeg*, *Papaw*, *Theobroma*, and *Vanilla*, and higher still into the region of *Coffee*, *Tea*, and *Chinchona*,

till at last the plateau is reached where is produced the *Orange*, *Pear*, *Apple*, *Plum*, *Wheat*, *Barley*, and innumerable other plants and fruits from the temperate climates of the world. And if this view of the cultivated products of this wonderful region be deeply interesting to the visitor, still more so is the natural scenery of the mountain gorge through which he has passed for a distance of some eight or nine miles, and rising in that distance to an elevation of 6000 feet. At an elevation of 3000 feet the scenery becomes bold, increasing in grandeur till huge walls of rock rise on each side of the road, every rift and cranny of which sends out its living mantle of everlasting green, while on one side of the path is a deep ravine choked up with a mass of forest verdure, on which you look down with awe and hear, but cannot see, the rushing and tumbling of a stream far in the depths below. Streams of water dashed into the whitest spray fall at intervals from the heights above down the face of the rocks, giving infinite beauty and grandeur to the scene. *Ferns* and *Lycopods* innumerable clothe the roadside banks, including species of *Adiantum*, *Microlepia*, *Davallia*, *Pteris*, *Angiopteris*, *Asplenium*, &c., while the graceful tops of the *Tree Ferns* (*Alsophila*) may be seen in every ravine pushing through the mass of other foliage.

On the plateau itself may be found wild in abundance the *Dog Rose*, *Honeysuckle*, *Cotoneaster*, *Hypericum*, *Passiflora*, *Rhododendron arborescens*, *Indigofera*, and numerous other flowers and shrubs. Many plants, such as the common *Groundsel*, *Oenothera*, *French Marigold*, and others, which have originated no doubt from seeds imported from England, have become acclimatised and now grow as weeds on cultivated grounds. I have seen the *Neddewattum Chinchona* plantation belonging to the Government literally covered with the *French Marigold*, the product of self-sown seed. The roads of this plantation are all hedged with *Box*, which is allowed to grow from 2 to 3 feet in height, and which looks very trim and beautiful. In addition to the numerous plants met with on these hills, both introduced and indigenous, the song of the thrush and blackbird is continually heard in the glens and woods.

The plateau is not rich in showy *Orchids*, but there are some at the higher elevations which are to be found in large quantities, and are very pretty. *Cœlogyne corrugata* and *C. odoratissima* are both found growing on sheet rocks, sometimes in large masses of ten or a dozen yards square, which are very lovely when in flower. These two plants, I believe, are supposed to be difficult to flower in this country, and this, I imagine, is from the want of proper treatment. I recently saw a large plant of *C. corrugata* at Kew in a house amongst other cool house *Orchids*; the pseudo-bulbs were very large, but the foliage was at least 3 or 4 inches longer than I have ever seen it in its wild state on the Nilgiris. The pot was at that time placed in a position at least 10 feet from the glass, and I was told that the same plant had been in the gardens for three or four years, but had never flowered. It ought to be remembered that these plants come from a climate where the maximum temperature is only 77°, and where the mercury frequently falls to 38°. They also grow on sheet rocks on the grassy slopes entirely unprotected from the bright sunshine and monsoon rains. They have also to undergo the annual privation of from four to five months of total drought without one single drop of rain to moisten their leaves or roots. I would humbly suggest to growers of the two *Orchids* named above that they never be subjected to any great heat, and be kept during the period of their growth in an open frame fully exposed to both sun and rain at least during the height of the English summer. On the slopes of the hills leading to the plains numerous *Orchids* are found, including *Dendrobium album*, *D. Pierardi*, *D. barbatulum*, *Vanda Roxburghii*, *Saccolabium* (several species), *Aerides crispum*, and numerous others.

In closing these articles I would give a word of warning to young gardeners about to go to India to engage in planting. In India with care there is little or no danger to be apprehended from the climate, and there is always the chance for a steady man to do well and save money. On the other hand, if extravagance be not avoided, disappointment and ruin will be the inevitable result.—PLANTER.

#### NOTES FROM BADMINTON.

BADMINTON, the Gloucestershire residence of the Duke of Beaufort, is one of the best known places in the west of England, but it is only of late years that the name has become so familiar with horticulturists. Mr. Nash, the well-known gardener in charge of the gardens having deservedly gained a good reputation both for fruit and vegetable culture. The park is undoubtedly one of the finest in the country. It comprises many thousands of acres of land well stocked with a variety of noble trees, and there are numerous fine avenues, delightful drives, and charming views, and fine droves of deer, to be seen by all who choose to avail themselves of the noble proprietor's liberality in throwing open the place to all comers. Of the pleasure grounds but little be said beyond remarking that they are kept in excellent order. It is a famous place for horses, hounds, and fox hunting, and pleasure grounds, conservatories, and flower gardens are quite a secondary consideration.

Not so the kitchen garden and fruit houses to which Mr. Nash has devoted so much time and labour with highly satisfactory results to all concerned. Large quantities of *Grapes* are grown, and well grown too; and strange as it may appear, the favourite variety is the *Black Alicante*, which is in demand early and late. It cannot by any means be termed a richly flavoured sort, no matter how well grown it may be, but it is considered most refreshing by the tired fox-hunter, hence the great demand for it. *Black Hamburgh*, *Madresfield Court*, *Gros Colman*, and *Muscat of Alexandria* are also grown in quantity, and in most instances

the crops, though heavy, were of excellent quality. Mr. Nash is an old "Colemanite," and attaches much importance to the process of renovating the borders, more especially from the front. There are several good Peach houses, including one recently contrived and built at a trifling outlay by Mr. Nash. Several fairly large trees were shifted into this house last March, and these were carrying fairly heavy crops at the time of our visit. Such old favourites as Stirling Castle, Bellegarde, and Barrington Peaches, and Elruge, Huut's Tawny, and Pitmaston Orange Nectarines are largely grown, and they frequently prove very hard to surpass. A long succession of Melons is maintained, several useful sunken houses being devoted principally to their culture. Sutton's Perfection is much liked, and there was a fine crop of it hanging, the old Golden Gem also being plentiful and in good condition. Cucumbers for all seasons are grown very similarly to Melons—that is to say, are not stopped till the top of the trellis is reached, the fruit being produced from the laterals and sub-laterals. When exhausted they are at once rooted out, the supply being maintained by successional plants, as in the case of Melons. This is found to be a better plan than depending solely on partially exhausted red-spider-infested plants so frequently to be met with. Cardiff Castle is the sort solely depended upon, and it would be a difficult matter to name a more generally excellent variety. Tomatoes also are in great demand, and a lot of plants in various stages of growth were doing good service in the Melon and Cucumber houses. Old Orangefield, Dedham Favourite, and Sutton's Perfection are the sorts grown, and all give good crops of excellent quality. In the plant houses are grown a useful assortment of plants, principally for house decoration. A fine plant of Tea Rose, Rubens, trained over the roof of one of the plant houses, is found to be invaluable. It yields flowers freely all the year round, and in the spring immense quantities of fine blooms are gathered from it.

There are eleven acres of kitchen garden, the greater portion being enclosed by fine old walls in good preservation, and which were erected in the year 1792. The Apricot wall is 14 feet high, and well furnished with trees, which, with the aid of blinds and fish nets, rarely fail to yield heavy crops. Ambrosia is very highly spoken of, and other Apricots that do well at Badminton are the Moorpark, Hemskirk, Early Turkey, Breda, a useful early sort, and Shipley, the best late variety. A great amount of wall space is devoted to Pears, and there are a fine lot of trees, which are principally horizontally trained. The most reliable sorts are Jargonelle, Williams' Bon Chrétien, Beurré d'Amanlis, Pitmaston Duchess, Hacon's Incomparable, Beurré Diel, Marie Louise, Glou Morceau, Josephine de Malines, Zephirin Gregoire, Winter Nelis, Beurré Rance, and Soldat d'Esperen. Peaches, Plums, Cherries, and a few Apples are also well treated, and altogether there are a fine lot of wall trees. They are not starved, all receiving a good share of the solid manure so very abundant at Badminton, and in most instances the roots have a 6 feet wide border to themselves. It is the vegetable crops disposed close to the walls that frequently ruin so many wall trees in other gardens. Apples were plentiful and good, Kentish Pippin being found one of the most generally useful sorts grown, various other good varieties, however, finding a place in the collection.

As before stated, the kitchen garden is exceptionally extensive, and under Mr. Nash's able management is made to produce enormous quantities of good vegetables. The soil is well and deeply worked, abundance of good manure being deeply mixed with both spits. In spite of the dry season Peas were plentiful late in August, Ne Plus Ultra and Sturdy being found the most reliable sorts, the quality in each case being of the very best. The yield of Potatoes is usually enormous, but this season abundance of haulm and roots were formed, but comparatively few tubers, this being most marked in the case of Scotch Champion. In addition to the last-named, Magnum Bonum is also extensively grown, the sorts preferred for the earliest supplies being Raehorse and Reading Russet. Large breadths of Broccoli, Brussels Sprouts, and other winter vegetables were in fine condition, while the Celery was exceptionally well grown. Lettuces were most plentiful, and equal to any we have yet tasted in a more favourable season. They are grown on wide deeply dug borders in which large quantities of old Mushroom bed manure being added to the soil. Black-seeded Brown Cos is considered one of the best for summer as well as winter use, and Veitch's Superb White Cos and Sugar Loaf are grown with it. Box edging has been gradually superseded by thin roughly dressed and locally quarried stones; these forming a neat edging, do not afford harbour for slugs, and are of no further trouble after they are once properly fixed. There are fine herbaceous borders running through the centre of the kitchen garden, these containing a great variety of useful plants and shrubs. The large bushes of Golden Elder just outside the walls were very beautiful, and the fine bushes of Galega officinalis alba were covered with flowers. The Moutan Pæonies have been grown to a great size, and are but little affected by the late severe winter. Large batches of Garraway's White Mignonette are grown for cutting from, and it is much liked at Badminton.—VISITOR.

#### JAPANESE CHRYSANTHEMUM MRS. J. WRIGHT.

THIS promises to be a valuable addition to the large-flowered Japanese section that exhibitors of cut flowers would do well to add to their collection. It was raised from seed by Messrs. John Laing & Co. of Forest Hill, and distributed last year by them to a few cultivators to test its merits. It was first brought into public notice at the Crystal Palace Autumn Exhibition, when Mr. Flight of Winchester showed two medium

sized blooms in one of his winning stands. After judging in the incurved classes, Mr. J. Wright of *The Journal of Horticulture* had his attention attracted to the bloom as being distinct, the colour pure, and the florets and flowers generally of good substance, and he thought it a promising variety. It proved to be an unnamed seedling, that year on trial, and the raiser then named it Mrs. J. Wright, as a compliment to one who we may say first discerned its merits, and who is, as many of the readers of the Journal know, a close observer of the Chrysanthemum. After a close inspection by all the judges the flower was unanimously awarded a first-class certificate, and that honour has this year been confirmed by the Royal Horticultural Society and the National Chrysanthemum Society.

The plant is naturally of a tall habit, growing from 6 to 8 feet high, and the bud from which the accompanying flower was produced was taken by Mr. Stevens about the first or second week in August. The flowers shown by him this autumn were all from crown buds, the terminals that were allowed to grow were much taller and produced very indifferent flowers in comparison. The bloom when first opening throws its florets out straight, but after being more fully developed they begin to curl and slightly contract, which gives the flower a somewhat smaller but more solid and beautiful appearance. It has been accurately described in the reports of the Journal. I may say that it is of good constitution, with light foliage, somewhat intermediate between Belle Paule and Fair Maid of Guernsey.—C. ORCHARD.

[Mr. Molyneux writes:—"This variety has not done well with me this year, but I have seen it in grand condition elsewhere, and it is quite first-rate." Mr. Tunnington observes:—"I am much disappointed with Mrs. J. Wright. The flowers, now half open, appear too light in build, though our plant is strong, and I had been proud of it all the season. I fear it will not prove a flower worthy of the name." The engraving is not in the slightest degree exaggerated.]

#### SEASONABLE HINTS ON FLORISTS' FLOWERS.

ALTHOUGH not perhaps so interesting a month to the florist as those in the early part of the year, when he is looking daily for the full development of the flowers he has watched over so carefully, it is nevertheless as important a one as any, for on the well-being of the plants there depends a vast deal of their future progress. If they have been neglected, and are in any way, either in the soil or plant, dirty; if the drainage of the pots is bad, or the frames where they are to be housed are not watertight, then mischief will ensue, and the loss of valued, if not valuable, plants or roots must follow. I am now writing of what we old-fashioned people know as florists' flowers—Auriculas, Carnations and Picotees, Pansies, Pinks and Ranunculuses, Tulips—added to which the Gladiolus and Chrysanthemum have put in a claim which cannot be refused; but of many other claimants, Pentstemons, Delphiniums, Calceolarias, &c., I must say you are very excellent in your way, but I cannot admit you into this brotherhood.

AURICULAS.—I should imagine that it has been a trying season for the Auricula. The long-continued drought has not been good for a plant, which, although it abhors stagnant water about its roots, yet is fond of moisture during the summer months. Although it is now a long time since its "forbearers" were induced to forsake their Alpine homes and become civilised, there is yet some of the old tendency left. During the summer months Alpine heights are exposed to heavy dews and mists, and all Alpine flowers rejoice in them, and get strength to bear the scorching sun. We cannot, and do not desire to imitate this; and now when we have brought them into their winter quarters, we must remember there is another condition attaching to them. They are there covered with snow and kept warm. This we cannot do; but at the same time we must avoid exciting the plants; keep them as restful as we can, and do not expose them to the alternating heat and cold of our winters. They should be kept as restful as possible, not allowed to get dust dry, but just kept from flagging. Should aphides appear on the leaves it will be better at this season not to fumigate, but to brush them off with a soft painter's brush. As to the woolly aphid of the roots, nothing can be done with it now, but in the spring, when the pots will have to be generally overhauled, it is desirable that the frames should be well looked over, and any deficiency in putty or paint remedied. Nothing is more injurious to the Auricula than drip, and therefore every possibility of its recurring should be carefully guarded against. Care should also be taken that the frames should be raised on bricks, for the present, at any rate, so as to allow a free ventilation of air about the plants. When the weather becomes more severe they may be withdrawn, and the frames allowed to stand upon the ground.

CARNATIONS AND PICOTEES.—With these, again, the chief



requisites are cleanliness and freedom from damp. I was somewhat unfortunate with my plants in pots this year, so many of them not throwing out grass for layering until it was too late. Mr. Douglas has, however, most kindly remedied this for me, and

must be guarded against, for although not so fatal as in the case of the Auricula, it yet sours the soil and leads to the unhealthiness of the plant.

GLADIOLUS.—I have never had my beds look so well and with



FIG. 49.—CHRYSANTHEMUM MRS. J. WRIGHT.

my own plants, which are now potted two in a pot, are looking well. They are placed in the pit where I bloom my Auriculas, and are thus easily looked over. At present all look remarkably well and free from any appearance of spot. With these, too, damp

so few showing symptoms of disease as this autumn, proving, as I imagine, that the dry season has been suitable for the corms. Formerly I should at this time have been busy lifting, but I have determined this year to wait until the middle or end of next month



before I do so. I did try my corms of "Shakespeare," one of the earliest blooming varieties we have, and found the corms large and clean, and if they were a fair sample of what I might expect I shall be very well satisfied.

**PANSIES.**—These have done very well with me this year. I grew my small collection in pots, and afterwards turned them out in a cool part of the garden, the coolest I could find. I adopted the somewhat lazy plan of dividing the roots, keeping the young root-shoots for potting up. They are looking well, being now in small pots, where they will remain until the spring placed in a cold frame and kept from damp and frost. I have now none but Fancy varieties, so completely have they jostled out the more refined Show class, their greater hardiness and rich and varied colours making them most desirable.

**DAILLIAS.**—The early October frost has made sad havoc with these very susceptible plants, and I fear seed savers, both of the double and single kinds, will be grievously disappointed. It will be now time to lift the tubers. They will be probably pretty ripe owing to the dry weather, and should be placed where they can be gently dried without fear of frost; damp being also in their case to be specially guarded against, as it causes rot in the roots.

**RANUNCULUS.**—The earlier or Turban varieties may be planted as soon as the soil is in good order, but these are not florists' flowers. This honour is reserved only for the later or Persian varieties, and with these nothing can very well be done at present. They may be looked over, just to see that they are free from damp, and are in some place clear of frost.

**TULIPS.**—Years and years ago I used to grow these, and have made many a pilgrimage to see collections of them in flower. I am old enough to remember journeying to Walworth to see Mr. Henry Groom's collection, in which bulbs were priced at fifty or a hundred guineas, but which did not at the sale fetch as many pence. I have also reminiscences of visits to private growers in the neighbourhood of London, but all these are matters of ancient history. Mr. Turner grew a fine collection for years, invited people to see them, but no one came, and at last in despair he gave them up. Will the taste ever revive? They are surely a most stately flower. They have, too, a history, as Mr. Polman Mooy, in his paper read before the Horticultural Club last year, and published in the Journal, clearly showed. The difficulty of growing them has been exaggerated. But if anyone did commence, where are they to get bulbs? Whether they are advertised in the north I know not, but one never sees an advertisement of them in the gardening papers. I believe that they are a most unsaleable commodity, and perhaps this is one reason why they are not put forward. We used to consider the 20th of November about the best time for planting, and very particular are Tulip growers as to the way they should be planted; what flowers ought to be in each row arranged according to height, &c. It seems absurd to say anything about planting when there are none perhaps to plant; but it may be as well to say that they require a rich soil, and when the bulbs are put in, a little silver sand should be placed round them. Here in the south I do not think the old plan of covering the beds is needed.—D., Deal.

### VINES IN POTS.

FOR an early crop of Grapes, or in cases where old Vines have been removed, and until the young Vines come into bearing, pot Vines are most useful for securing a crop without causing a break in the supply. Vines that are forced early decline in vigour much sooner than those that are not started until the turn of the new year, and in these cases it is preferable to grow the early supply from pot Vines. Planting out young Vines in brick pits in small houses has been advocated in the Journal, and an excellent plan it is, as we can testify from temporary Vines in later houses; but in the majority of cases these small houses are not at command, or are required for growing other plants later on after the pot Vines are cleared out. In our case a crop or two of Melons, or a good crop of Tomatoes can be grown, allowing ample time for the house being properly cleaned before the pot Vines are introduced. Last season we were fairly successful in their production. Bunches of Black Hamburgs turned the scale at 2 lbs., and in some cases 3 lbs., and Muscat of Alexandria 4 lbs.; but in the case of the Black Hamburgs we give preference to bunches which weigh about 2 lbs., as they are invariably better finished. I am under the impression that many pot Vines are ruined through receiving too much water in the early stages of growth, for if freely watered before the roots become active the latter will perish. Very little water is required until fresh roots and active feeders form, but by the time the Vines are in free growth liberal supplies should be afforded. Attention in watering and feeding is the secret of success in the cultivation of pot Vines, for if allowed to become dry or flag failure is certain.

The principal pot Vines here are grown in a lean-to Melon house;

brick pedestals are built up for standing the pots on, but previous to the pots being placed in position a layer of good fibry turves is placed on the top; the crock holes are also enlarged to permit the egress of the roots. The old surface soil down to the roots is removed and top-dressed firmly with good loam, and a sprinkling of fine bone meal or Thomson's Vine manure. After all the pots are placed in position water is given to settle the surface soil, and the pit filled firmly with Oak or Beech leaves so as to generate a bottom heat of 70° to 75°. It is the usual practice to remove the lower buds up to the trellis after they have started, but last season we allowed the lower buds to extend to five or six leaves, and which helped to swell up the stem to a large size; in fact they were treated in this respect as recommended by Mr. W. Taylor for building up the stems of permanent Vines. The Vines being short-jointed, all shoots for which there was not room for laying in as laterals were pinched to two leaves; this helped the upper part of the rods to swell considerably, and had a great influence on the crop.

From the time the Vines were started water was only applied when really necessary, the leaves helping them in this respect. The after treatment as regards temperature, stopping, &c., was of the usual kind. After the Grapes were thinned care was taken that the Vines did not suffer by the want of moisture at the roots. Liquid manure (made of cow manure and soil) was freely applied, and surface dressing once a week of Standen's manure, and occasionally of Thomson's Vine manure. As the roots came to the surface a layer of loam, wood ashes, and pulverised cow manure in equal parts was placed on as required, this causing a plentiful supply of active surface feeders, ready to take up whatever was applied. These repeated surface dressings made it necessary to place a ring of turf around the rims of the pots to hold water.—A. YOUNG.

### BULB BEDS.

IN preparing borders for mixed bulbs nothing further is needed than good soil 18 inches to 2 feet deep, enriched and stirred. If manure is added it should be short and fresh. There is very little virtue in manure reduced to a soapy mass. It, at best, is not more valuable than leaf soil, if, indeed, so good. The soil being a heavy loam overlying clay, it was mixed with leaf soil and the *débris* of the rubbish heap, the woody portions being charred, in about equal parts, and put on a foot thick, mixing it with the soil below, and stirred about a foot deeper, but not bringing the stubborn material to the surface. Drains with proper fall and outlet may be provided in some cases, 3-inch pipes laid 3 feet deep or more. In one case, the soil varying considerably, gravel was found within a foot of the surface. About 18 inches depth of the gravel was taken out, and a mixture put in of strong loam, leaf soil, and the rubbish heap in equal parts, with a fourth of sand, the whole thoroughly incorporated. In all instances the beds are raised about a foot in the centre. There are three beds, two have a background of evergreen shrubs to the north. The idea in one bed, a round one, is to have white and sweet flowers only. Crinum capense disposed 3 feet apart, the outside ones about 18 inches from the sides of the bed. They are planted so that the bulbs are buried 4 to 6 inches deep. These are simply magnificent in foliage. At 18 inches apart are *Lilium longiflorum* *Harrisi* planted 4 inches deep. They have been lovely, and alternately with the *Lilium* is *Anthericum Liliago* in the centre and *A. liliastrum* near the margin—*ie*, 9 inches from it; and at 9 inches all over, excepting, of course, where the other plants are placed, there are *Belladonna Lilies*, which are planted 4 inches over the bulbs. It ought to be stated that the bulbs in all cases have a little sand placed under, around, and over them. I have only one suggestion to make, and that is an edging 6 inches from the grass of *Zephyranthes candida* and var. *minor*.

Another idea was to have a mixture of bulbs in an irregular-shaped bed, and it is a decided success. *Tritoma nvaria nobilis* was planted 6 feet apart, the whole surface being then set out at 2 feet apart, and in those places are planted in about equal proportions *Lilium speciosum album*, *L. speciosum roseum*, *L. tigrinum* var. *splendens*, *Gladiolus gandavensis* var. *brenchleyensis*, and *Galtonia* (*Hyacinthus*) *candicans*. At a foot distance apart, excepting where preoccupied, about equal proportions of German Iris, *Iris Susiana*, *Lilium Thunbergianum*, *L. candidum*, *L. croceum*, and Crown Imperials (*Fritillaria imperialis*), and on the margin there are *Narcissi* of the bicolor and *incomparabilis* class, which are also dispersed through the bed along with *Gladiolus* of the *blandus*, *byzantinus*, and *cardinalis* type. In this bed there is a display of *Narcissus* and Crown Imperials, then of Irises, followed by the *Liliums* *Thunbergianum* and *candidum* with the early *Gladioli*, afterwards with Orange Lily with the *Galtonia*, and *Gladiolus brenchleyensis*, the white of the *Galtonia* and scarlet of the *Gladiolus* being in combination unique with the Tiger Lilies; later come the second stems of the *Galtonias* with the *Lilium speciosum* vars., and the *Tritomas* bring up the rear,

lending colour to the Galtonias and Lilliums, which prolong the bloom into October. The Galtonia and Lilium speciosum were very effective even as late as October 21st, and there is the greenery of the German Iris and Lilium candidum; in fact, this arrangement is never without interest, and there is always something to charm from April to November inclusive. In this bed are a few bulbs of Lilium auratum and some Tuberoses. The Golden-rayed Lily does well, but the Tuberoses have their spurs to win. Perhaps it would be an improvement to introduce a margin of Winter Aconite, Snowdrops, Crocuses, and Scilla sibirica.

The other bed is a regular shape on grass in the open. It has Day Lily (*Hemerocallis flava*) at 4 feet apart, and *Alstromeria chilensis* vars., with *aurantiaca*, *peruviana* vars., and *A. aurea* at 2 feet apart; and at 1 foot apart Spanish Irises, *Lilium aurantiacum*; and at 6 inches apart Hyacinths and Parrot Tulips. The best display is made by the Parrot Tulips, and the Irises, the Day Lilies, and Orange Lilies help to fix the eye and take off the monotony. The Hyacinths are set off by the comparing greenery, and the *Alstromerias* are quaint and effective, keeping on up to frost. These merely require attention to weeding in summer, and a surface-dressing in autumn of partially decayed leaves or spent manure—that of an old Mushroom bed or hotbeds that have been formed of dung and leaves. Be the winter ever so severe no harm is done with the mulching, but a little dry hay may be used as an extra precaution against harm in a severe weather, with which aid the most tender passed safely the severe winter of 1886-7. The situation is 300 feet above sea-level, formation chalk. A mulch of cocoa fibre refuse in summer would be a manifest advantage, but it was not used this year.

I have jotted down the foregoing as indicative of a change in favour of a much-neglected class of plants, a desire to have beds and borders that will have something of interest and beauty at all seasons. The idea could be extended with great advantage to many hardy and even half-hardy plants which are now excluded by the prevailing taste for masses.—G. ABBEY.

### CHRYSANTHEMUM NOTES.

#### MR. MEASE AND THE HULL CHALLENGE CUP.

THE remarks of "A Chrysanthemum Grower" on page 364 respecting the report that Mr. Mease is ruled "out of competition" at Hull this year is a great surprise to me, as it will be to many others. If that report is correct, I think, and hope, that such action of the Committee of the Hull and East Riding Chrysanthemum Society will be the death blow to that kind of competition. On referring to the Hull schedule for 1886 I find that rule 15 gives them the "right to reject any exhibit." The same rule is also in their schedule for 1887. Had that rule been omitted from the schedule for either year, I am of opinion that Mr. Mease could not have been debarred from competing in the class for the challenge cup this year; but under the circumstances I suspect the Hull Committee are within their legal rights, but whether that far higher law—*i.e.*, the moral law—is equally on their side, is quite another matter.

"A Chrysanthemum Grower" has conferred a boon on Chrysanthemum exhibitors by making public the case of Mr. Mease, if it is true; if untrue, then I shall expect to see an official contradiction of the statement in your next issue. It is not possible to form a perfectly correct opinion of this matter, because we are not informed whether Mr. Mease entered the flowers originally in his own name, or whether he entered them in the name of his employer. This is a distinction with a difference, and the whole case turns upon it. Whether the Hull Committee are right or wrong in their action, the system under which the cup was offered is to blame, for had that not been in existence, the unpleasant experience of Mr. Mease would not have happened. The men of Sheffield have pluckily set a better example by offering a very valuable cup and a handsome prize in cash to the first winner, and it is to be hoped that our best Chrysanthemum growers will show their appreciation of the "new departure" by making a grand effort to obtain the magnificent prizes so generously offered on two separate occasions in that town.—J. UDALE, *Elford*.

I LEARN from the letter of "A Chrysanthemum Grower," in your Journal of the 27th inst., that in consequence of the death of my late lamented brother and sister, Mr. Mease is not to be allowed to exhibit his plants in Hull on the 17th prox. I should be glad if you could inform me on what grounds, or according to what rule of the Society such a decision has been arrived at. Mr. Mease is cultivating the plants at my request and at the expense of the estate, for he still holds the position of gardener at Wyncote.—T. F. NEUMANN, *Executor of the late Mr. and Mrs. C. W. Neumann*.

It is greatly to be regretted that owing to exceptional circumstances the winner of the Hull challenge cup has no opportunity of winning it finally. What are the facts? Should the same exhibitor win the cup twice consecutively, or three times altogether, it becomes his property. The winner of 1885 failed to attain to the first position in 1886, otherwise it would have become his property. The winner of 1886 cannot finally win it this year, owing to the lamented death of his employer in

the interval. He has, however, been allowed to keep the plants by the executor for the purpose of this competition. If the winner of 1885 wishes to perform a graceful act he should announce that if the winner of 1886 enters and successfully competes this year, he will waive all future rights in the competition so far as the winner of 1886 is concerned. I believe the Hull Committee would be unanimous in wishing to have the competition as between these two noted growers decided, whoever else may enter the contest.—A MEMBER OF THE HULL COMMITTEE.

IN reply to "A Chrysanthemum Grower" in your this week's issue, allow us to say that the decision of our Committee not to allow Mr. Mease to compete for the challenge cup of this Society, "as the holder of the cup" was arrived at after consulting the best horticultural authorities and taking legal advice on the matter. The circumstances of the case to be decided are very exceptional, and it is therefore necessary to carefully consider the interests of all parties—that of the Committee as well as the exhibitors. Your correspondent writes quite in the interest of the present holder of the cup. We had to consider our position in regard to Mr. Lindsay, for Sir T. Edwards-Moss, because in case the cup was won again by Mr. Mease (for the executors of the late Mr. Neumann) he might protest against its being finally handed over to them. The Society is advised by its solicitor that the property in the cup only rests for one year, and is personal to the late Mr. Neumann. Much as the Committee desire to give Mr. Mease a chance of winning the cup finally this year, they cannot be blamed for following legal advice, and having some regard for the possible "trouble and annoyance in the future, and perhaps legal proceedings," to which your correspondent refers.

Let us, however, add that Mr. Mease is not excluded as a competitor. It is quite open to him to enter the competition, either personally or on behalf of his employers, the executors of the late Mr. Neumann, and if he wins the cup it will be handed to him as the winner in whichever capacity he enters, but it will have to be returned to the Society at the end of the year in accordance with the rules. Our Committee having taken legal advice must follow it. They have no other course.—EDWARD HARLAND, JAMES DIXON, *Hon. Secretaries Hull and East Riding Chrysanthemum Society*.

[This will answer the letter of Mr. Neumann better than we can and the suggestion of "A Member of the Hull Committee" will also be noted by those who are interested in the subject.]

#### NEW VARIETIES.

MANY of the newer varieties seem inclined to be flowering too early for exhibition. We have many now almost at their best, such as the following:—Annie Clarke, Charlotte de Montebrier, both very fine blush pink rose; Favourite, a beautiful blush variety; La Triomphante, a splendid flower, which has been described previously in your columns; M. D. D. Hillier, a noble flower, crimson and gold, a fine variety; Ornaments, a very fine colour, after the style of Tokio, but a much larger bloom; M. H. Elliott, a very curious salmon, suffused with cerise, a large flower; Salmoneum plenum, another handsome salmon tinted variety; Mr. Wm. Clark, quite the best of this class, a bold well-formed flower; William Stevens, should be in every collection, a well-formed bronzy red; Phœbus, very large flower of golden amber; Edouard Audiguier, very fine, of a splendid velvety maroon; J. H. Laing, very handsome; Jupiter seems a delicate variety, though a fine flower of the orange scarlet type; Snowstorm, promises to be a very fine white; Mme. la Marquise de Mun, Mr. Deville, and Exposition de Troyes, the two former with ground silvery white, suffused with pink, the latter a beautiful pink, a fine noble flower; J. A. Laing is a very promising salmon colour, with twisted petals; M. Castel is a beautiful variety, crimson gold tipped, a very showy flower.

Of the older varieties the most notable are:—Bacchus, Commandant Baco, Coquette de Castille, Criterion (very fine), Emeraude, Etoile du Midi, Garnet, Henri Jacotot (very fine), Joseph Mahood, J. Délaux (very large), La Triomphante (has come very fine with us), Marguerite Marrouch, Mr. Townshend, Mme. C. Audiguier (very large), Mme. Clos (a fine Anemone), Mdlle. Laeroix (seems to be good with most growers), Peter the Great, R. Ballantine, Tisiphone (a very useful variety, though small), Triomphe de la Rue des Chalets (very promising). I should have included M. N. Davis in the new varieties, as it is a very pleasing colour and good flower. Amongst Anemones and reflexed Cincinnati seems likely to be a telling variety. Cullingfordi will be good in a week; in fact, the whole of the sorts mentioned are nearly at their best. Most of the incurved varieties are ten days later. I have named the above with a view to see if some of my southern friends will mention which have come earliest with them, most of these are from crown buds.—A NOTTS GROWER.

#### CHELSEA.

MESSRS. J. VEITCH & SONS for many years past have provided an annual display of Chrysanthemums in their King's Road Nursery, comprising both novelties and old varieties of proved merit. This season the usual number of plants are grown, a large span-roofed house being filled with them, and besides that an avenue of plants is formed in the Camellia house near the Brompton Road entrance, which has a very pleasing appearance. No special effort is made to obtain the plants in flower early, and it is found much more convenient to have a good display at the time when so many Chrysanthemum admirers are visiting the numerous metropolitan shows. The first and second weeks in No-

vember are the best times for inspecting Messrs. Veitch's exhibition, but in common with others they are this year rather later than customary.

All the best of the numerous Continental varieties grown, and there is a fine stock of incurved, Japanese, and the other sections, but in addition to these the varieties raised by Mr. A. Salter and sent out by this firm include some of great merit. The Japanese variety Phœbus, sent out last year, we have repeatedly noted before, and it is worthy of general cultivation both for its fine clear yellow colour and good form. The list of all those raised by Mr. Salter may be interesting, as English seedlings are by no means numerous, though of course the seed was not ripened in this country. The years indicate the time when the varieties were sent out by Messrs. Veitch & Sons:—1882—Lord Beaconsfield (Jap.), salmon red, shaded amber yellow; Marquis of Lorne (Jap.), reddish carmine semi-globular flowers; Mary Major (Jap.), beautiful white variety; Rex rubrorum (Jap.), deep-red shaded with crimson. Pompon, early flowering—Anastasis, pink shaded magenta, fragrant; Inimitable, bright amber yellow; Virginia, pure white, the best of the early whites. Brunette (late flowering Pom.) amber yellow.—1883—Mrs. Cullingford large, pure white (early flowering); La Candeur, pure white (large flowering); Royal Purple, bright purple (large flowering); Sir Beauchamp Seymour, bronzy red (large flowering), Duchess of Albany, pure white, outer petals tinged lilac (Jap.); Lucifer, vermilion red (Jap.); Tisiphone, petals threadlike, bright orange red (Jap.).—1884—Annie Holborn, white, tinged with lilac (Jap.); Comet, bronzy reddish rose (Jap.); Distinction, golden yellow, striped scarlet (Jap.); Duke of Teck, rosy mauve suffused with white (Jap.); Gloria Solis, bright golden yellow (Jap.); Salteri, deep red, passing to scarlet (Jap.); Single white, a good white (Jap.), single flower.—1885—Maid of Athens, pure white, very late (Jap.); Mary Salter, white, broad petalled (Jap.); Rob Roy, centre orange red, shaded yellow (Jap.); Tubiflorum, pale rose, passing to white (Jap.); Prince of Orange, bright yellow shaded orange (large flowering); Talfourd Salter, bright red tipped yellow (reflexed large).—1886—Lady Rosebery, satiny rose (Jap.); Megara, narrow thread like petals, golden yellow (Jap.); Mrs. Weldon, mauve pink, quilled (Jap.); Phœbus, bright canary yellow (Jap.); Rosy Morn, rosy pink (Jap.); Memnon, deep carmine, shaded with violet (large flowering); Ruby, rich ruby red shaded with maroon (large flowering).—1887—Alice Bird (syn. Buttercup) bright yellow (reflexed); Aspasia, pale satiny rose (reflexed); Irene, pale soft rose (reflexed); Aurantia, bright orange yellow (Jap.); Janira, deep carmine red, toned with purple (Jap.); Melton, brick red, reverse nankeen yellow (Jap.).

The plants are all very healthy, dwarf, and well clothed with good foliage, and there are large numbers of substantial buds to open. Amongst the Japanese already out the following are the most noteworthy—Alfred Chantrier, Charlotte de Montebrier, Ornaments, W. Holmes. Phœbus, Brise du Matin, Boule d'Or, Lakmé, J. Delaux, and Mr. J. A. Laing.

#### ROEHAMPTON.

Passing Putney Heath, the right hand road in the direction of Roehampton leads to several good gardens where Chrysanthemums are prized, and amongst them being Dover House, Roehampton House, and Downshire House, a trio of establishments where Chrysanthemums are skilfully grown and gardening carried out with some spirit. Dover House is the residence of J. S. Morgan, Esq., and Mr. Forbes, the gardener in charge, has distinguished himself as an able cultivator in every department of an exceedingly well-kept garden. About 700 Chrysanthemums in all are grown, but the principal group of flowering plants is arranged in a span-roofed greenhouse or conservatory, later plants occupying the Peach houses, of which there are two remarkably long ranges. Very conspicuous in the group mentioned are plants of Elaine with large substantial pure white blooms, which deservedly render this variety such a favourite one for cutting. Japanese varieties predominate at this early date, and Phœbus is again especially notable for both size and colour. Belle Paule is expanding well, and there are some fine examples of Margot, Fernand Feral, Chang, Chinaman, and L'Île des Plaisirs. The handsome richly coloured reflexed Cullingfordi is looking extremely well, while one of the best of incurved varieties set out is Jeanne d'Arc of admirable substance. Late in October is not the best time to visit Dover House Gardens, except to see the Chrysanthemums, but a cursory glance through the ranges of vineries and other houses is amply sufficient to indicate how much can be done by a judicious liberality in expenditure under the direction of a practical man.

One portion of the grounds attached to Roehampton House, the residence of the Countess of Leven and Melville, adjoins the preceding estate, and there we found Mr. Berry busy amongst his favourites, but in common with other growers lamenting the tardy development of buds and flowers. Some 300 Chrysanthemums are grown in the exhibition style, and incurved varieties have for many years formed a prominent feature in the collection. Now Japanese are so abundant and the majority so easily grown, there is a danger that the incurved may be neglected, and admirers of these exquisite blooms cannot but feel thankful to the older growers who still give their close attention to those varieties. At present Mr. Berry has a number of the earlier Japanese in flower, and there are grand blooms from both crown and terminal buds. Unusually fine are Madame Desbrieux, M. Delaux, Mlle. Lacroix, Elaine, and Belle Paule, while scores of others are advancing steadily. A conservatory is just being completed for the plants, and when arranged in that they will form a beautiful group. In vineries and other houses it is difficult to see these plants to the best advantage.

Downshire House is situated on the opposite side of Roehampton Lane, but quite near to the last named, and there the occupier, D. B.

Chapman, Esq., enjoys a well-kept garden, and a varied rural prospect in the direction of Richmond Park. The gardener, Mr. Sullivan, has an extensive charge, every department of which is creditable to his energy and ability, but he also manages to include a collection of some 500 Chrysanthemums that are promising some highly satisfactory blooms. Here, again, the peculiar retarding effect of the season is apparent, and in it seems that some exhibitors, even in the south, will find it difficult to have their blooms fully cut for the earlier shows. Whether it was the cold late spring, the exceptionally dry summer, or the effect of both, it is hard to say, but the general complaint is that Chrysanthemums suffered a check before they had completed their growth. In some cases the results of insufficient water supply are apparent in deformed or stunted buds, but happily Mr. Sullivan is little troubled in this way, the majority of his plants being in excellent vigorous condition, not gross, but clean and healthy, the buds showing this character by expanding steadily and evenly. The collection comprises most of the leading varieties both of Japanese and incurved, and we shall expect to hear something more of the blooms from this establishment during the season.

#### WARREN HOUSE.

Mr. G. Woodgate, Lord Wolverton's able gardener, grows Chrysanthemums well at Warren House, near Kingston-on-Thames, and not many cultivators know the special requirements of different varieties better than he does. The plants are not grown luxuriantly, compact well-finished blooms being the chief object in view, nor are they grown mainly for exhibiting. Mr. Woodgate wisely recognises the first claim of the family he serves, and cheerfully cuts any blooms that may be wanted by them, yet he has generally some to spare for showing, and is seldom left out of the circle of prizewinners. Amongst the noticeable varieties were Mr. Cannell's introductions from Japan—the welcome quartet—Mr. Cannell, Mrs. Cannell, Edwin Molyneux, and C. Orchard. The first is yellow, the second white, the third rich crimson, and the fourth pale chestnut. They are of the "Dragon" type, and promise to develop handsome blooms. Stanstead White was bearing fine and very attractive blooms; and others expanding well were Carew Underwood, Ralph Broeklebank, Mrs. J. Wright, Gorgeous (a broad-petalled yellow American variety), Mr. J. J. Hillier (apparently the same as John Laing), and Martha Harding. The noticeable incurved flowers were four fine blooms of Novelty on one plant, Lord Wolseley good, Prince of Wales very deep, Jardin des Plantes, and Prince Alfred, with others less advanced yet coming to time satisfactorily. The noble standard and columnar Sweet Bays on the terrace are not often seen equally fine in this country, and a large house is in the course of erection for wintering them. The garden is also celebrated for Carnations, of which Lady Wolverton is a great admirer, and Mr. Woodgate strives to do all things well.

#### FINSBURY PARK.

The exhibition of Chrysanthemums at Finsbury Park was opened to the public recently, and has already attracted a large number of visitors. This display has become very popular in the north of London; the plants are well grown and effectively arranged, constituting a show of considerable beauty. About 2000 plants are grown, but the exhibition house, which is 100 feet long by 18 feet wide, will only contain 500 or 600 of the large specimens, the others being utilised for stock. The plants are disposed in two sloping banks at the sides, with a broad path down the centre, and as the visitors are only allowed to enter at one end and pass through no confusion is caused however large the numbers may be. The collection of varieties is a large one, comprising many new or recent introductions, as well as the standard stock of incurved, Japanese, reflexed, Anemones, and Pompons. The Japanese are much more advanced than any of the others, and Comte de Germiny, which is always grown well there, is largely represented, the blooms being abundant and of good size. Of Tendresse, M. Tarin, Elaine, Album plenum, Frizou, M. Roux, chestnut red, with yellow reverse; the bronze red Joseph Mahood, and M. Henri Jacotot are all in first-rate condition. M. J. Laing, of a reddish brown hue; Alfred Chantrier, bronze red, with long quilled florets; Flamme de Punch, M. Delaux, and M. Moussilac also have fine blooms. Amongst the incurved Mr. Bunn, G. Glenny, Aureum multiflorum, and Golden Beverley are the most advanced, fine clean blooms. A hybrid Pompon of a bright red colour named Paul & Son is likely to be a useful decorative variety, but Laing's Anemone does not seem to be keeping its character as seen last year. The Superintendent, Mr. Cochrane, entrusts much of the management of the Chrysanthemums to his foreman, Mr. Madlin, who gives close attention to the plants with very satisfactory results.

#### HACKNEY.

Mr. Wm. Holmes of the Frampton Park Nursery is well known in the Chrysanthemum world, and he has this year provided an interesting display of plants in one of his houses at Hackney. He also has two houses devoted to new varieties at his Plaistow nursery, and at both places the plants are well worth seeing. At Hackney they are grown more in the usual exhibition style, and a handsome group is formed of the leading Japanese and incurved varieties, many of which are now advancing rapidly, and developing fine blooms. At Plaistow, however, the plants are remarkably dwarf, having been stopped the second week in June, and the success of this practice has been conclusively proved by the handsome blooms they are bearing, being fully up to exhibition quality. They range from 18 inches to 2½ feet high, compact vigorous specimens with four to six blooms each, and are invaluable for grouping purposes. The new varieties include many of great promise, to which we shall have occasion to refer in another issue.—L. CASTLE.



## NORTHERN SHOWS—A CHALLENGE.

FOLLOWING closely on the heels of Mr. Molyneux in his tour amongst the northern Chrysanthemum growers I found a great deal of interest evoked by his notes as published in the Journal. There has been a strong rumour that Mr. Molyneux intends to exhibit at Sheffield at the forthcoming Show there, and some of the growers have an impression that one object in his northern journey was to view the nakedness of the land, and to see his chances of success if he ventured so far north as an exhibitor, and most growers, both great and small, with whom I am acquainted would be delighted if Mr. Molyneux would exhibit, say at either Hull on the 17th, or Sheffield on the 18th, or Liverpool on the 29th. In the first place, by so doing Mr. Molyneux would give small growers and beginners an opportunity of judging for themselves as to the results of his teachings as set forth in his book on "Chrysanthemum Culture," and in the second place it would probably settle the vexed question as to the quality of flowers South v. North, and Mr. Molyneux has never yet exhibited in the north he would have the opportunity of winning liberal prizes and vindicating his position as champion grower. At present the northern growers object to his title as such until he has met them and vanquished them on their own ground.—W. D.

## MEASURING BLOOMS.

I HAVE thought it may interest some of your readers if I were to describe a simple inexpensive contrivance we have in use here for measuring Chrysanthemum blooms. It consists of a thin deal board a foot square, on which is marked consecutive rings a quarter of an inch apart, all being drawn from the same point—the centre of the board. A slot wide enough to take the flower stems is made to the centre, and

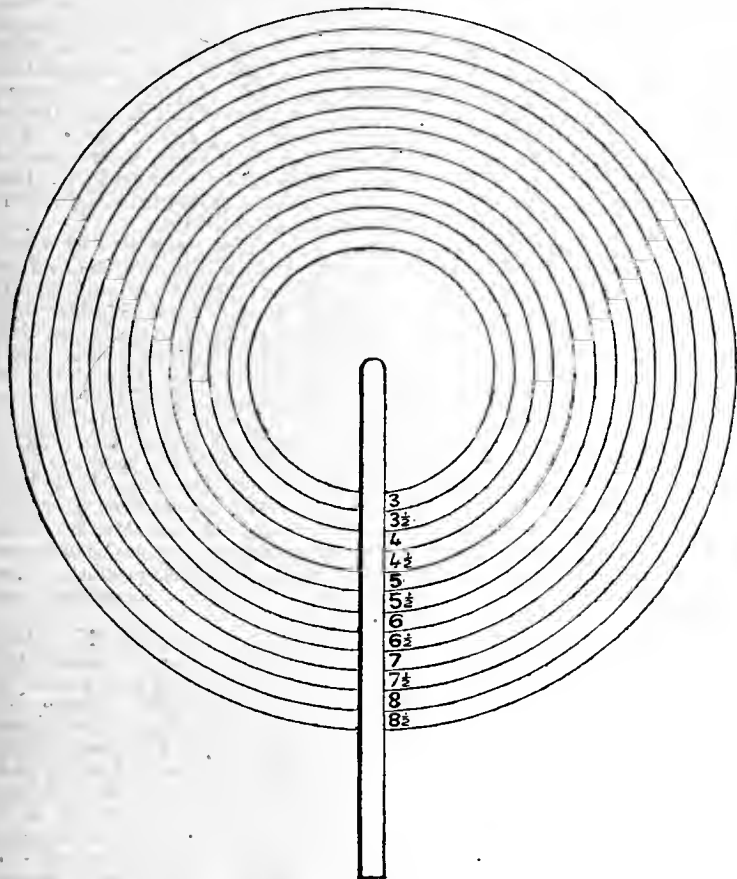

Fig. 50.

on the outside of each circle is marked its diameter, which multiplied by 3 gives its circumference. A flower any size can thus be measured much more correctly and quickly than by any other method that I am acquainted with. I send with this a rough sketch of our board, which you may reproduce in a reduced form in your pages if you think well. Our board is 9 inches in diameter.—THOS. WINKWORTH.

## DEEP CULTIVATION—GAS LIME.

THIS subject has been previously so much discussed and approved by experienced men, that I am much surprised at the statement made by Mr. Iggulden on page 300, that was very ably responded to by your correspondent "A Thinker," which leaves but a narrow margin for any addition to be made, except that the majority of experienced men would rather agree with him than with Mr. Iggulden. In my opinion Mr. Iggulden's statements are very misleading, for to obtain such crops with so little labour he must be favoured with exceptional advantages. There are few, I think, who will dispute the advantages of "intelligent deep cultivation." Certainly due consideration is required in the practice, and a thorough knowledge of the ground to be operated upon is necessary. It is not wise (quite the reverse) to bury good soil 2 feet deep, and bring to the surface that which is so much inferior. If the subsoil is good and has been previously double dug or trenched no harm can be done in

bringing it to the surface. Much depends upon the nature of the ground to be worked. If very heavy frequent double digging is beneficial, but if light this operation need not be so frequently performed. There is not so much labour in the operation as many are inclined to think, for after a piece of ground has been double dug and exposed to the influence of a winter's frost, it will grow two or three crops without being even plainly dug again; in fact for some crops, such as the Brassica tribe, the firmer the ground the better, especially for those which are required to stand through the winter. By judicious management ground can be beneficially deeply worked without running the risk of having "coarse vegetables." If ground is in fair order no manure is required for such as Beet, Parsnips, or Carrots. For the latter a good dressing of gas lime is most beneficial, especially if it is an old garden, and in any ground that is found to contain wireworm gas lime is the best remedy, but should be put into the ground for some time previous to sowing or planting—about one bushel to 20 square yards, and worked into the ground directly. Great care is necessary in the use of it; if used too freely it will destroy the first crop put in. Writing of the use of gas lime reminds me of a farm bailiff I knew, who, in preparing some ground for the cultivation of roots, Carrots, Mangolds, &c., for exhibition purposes, dressed the ground too heavily with gas lime, with the result of destroying two sowings of the seeds. I usually manage to have a portion of ground double dug every winter, and that portion I generally sow with Peas, for no crop I consider pays better for good cultivation than Peas. Ground that is deeply worked is much drier than that which is not, consequently it is proportionately warmer and better suited for the quick growth of vegetables.

Mr. Iggulden's personal remark concerning "A Thinker," whether true or otherwise, is not calculated to be generally interesting to correspondents or readers of the Journal, and the less such remarks are indulged in the better, as they can serve no useful purpose, and often are mischievous in the end.—W. SIMPSON, *Knowsley*.

## THE STRUCTURE OF FLOWERS WITH REFERENCE TO INSECT AID IN THEIR FERTILISATION.

(Continued from page 366.)

THE last, but not the least remarkable example of the adaptation of flowers to the visits of insects for the purpose of fertilisation to which I will allude is that of the Orchidaceous family of plants. The flower of the Orchis is very abnormal. Its genera vary amazingly in the structure of the anther, the column, the lip, and indeed of all parts, but in the consolidation of the style and stamen they are all agreed. "The flowers," to quote the words of an eminent modern botanist, Otto W. Thomé, "are rarely solitary, usually in spikes, racemes, or panicles; and the superior perianth consists of two whorls, each of three leaves. Of these, the inner whorl is always irregular, and often has a spurred lip or labellum, the remaining five leaves of the perianth forming together the galea or helmet. The stamens are united with the style into a fleshy column or gynostemium, upon which the anthers are so placed as to stand above the stigma, which is but little developed, and consists usually of a large viscid surface. Of the six stamens which are probably originally present, only one, less often two, attain perfect development. When only one is thus developed, it is always opposite the labellum; but when two, then one is on each side of the gynostemium. Only a few Orchids have the pollen grains perfectly distinct; usually they are united together in fours, and these again into granular masses; or the grains are combined by a viscid fluid into a club-shaped mass or pollinium within each anther lobe. The two pollinia terminate at their lower end in a pedicel consisting of the dried-up viscid substance, connected together by a viscid gland or rostellum, as in the Bee Orchis, or distinct, as in Orchis morio."

If we dissect a flower of the early purple Orchis, we shall find that the stigma is bilobed, and consists of two almost confluent stigmas. It lies under the pouch-formed rostellum. The anther consists of two rather widely separated cells, which are longitudinally open in front: each cell includes a pollen mass or pollinium. The pollinium consists of a number of wedge-shaped packets of pollen grains united together by exceedingly elastic thin threads. Below the pollen mass is the elastic caudicle. The end of the caudicle is firmly attached to a viscid button-shaped disc. Each pollinium has its separate disc, which has a ball of viscid matter at its under side. The rostellum lies immediately below, and the balls of viscid matter lie concealed within it. Let me now try to explain how this mechanism acts. Suppose an insect, say a bee in search of honey, to alight on the labellum, which forms a good landing stage, and to push its head into the chamber, at the back of which lies the stigma, in order to reach with its proboscis the end of the nectary, or what does quite as well to show the action, push a sharply pointed lead pencil into the nectary. Owing to the projection of the pouch-formed rostellum, it is almost impossible to push an object into the gangway of the nectary without touching the rostellum. When this is effected one or both of the viscid balls will almost invariably touch the intruding body. These balls are so viscid that they stick firmly to whatever they touch, and the viscid matter sets hard and dry like cement within a minute or so. As the anther cells are now open in front, when the insect withdraws its head, or when the pencil is withdrawn, one or both pollinia will be withdrawn firmly attached to the object, sticking up like horns. The firmness of the cement is necessary, for if the pollinia were to fall sideways or backwards they would never fertilise the flower. Now let us suppose the insect to fly to another flower, or insert the pencil with the pollinium attached into another

nectary. If this be done at once it is evident that the pollinium will be pushed into or against its old place, the anther cell. How, then, can the flower be fertilised? This is effected by a very beautiful contrivance. Within a minute the pollinia, by the contraction of the minute disc to which they are attached, move downwards to an angle of about 45° from the first upright position. When the insect sucks the next flower the pollen masses come in direct contact with the stigmatic surface. The stigma is so very viscid that it is certain to pull off some of these pollen packets and rupture the threads. The whole pollinium is scarcely ever retained by the stigma, so that one pollinium serves to fertilise several flowers. So economical is Nature in her workings that even a few pollen masses are not unworthy of her sedulous care.

Of all the pollen-carriers, and consequently flower-fertilisers, bees are the most assiduous. Attracted by the gay colours of the corolla, sweet scent, or the prospect of honey, they visit most flowers that are incapable of self-fertilisation. That bees can distinguish between one colour and another, and that they exhibit a preference for certain colours has been clearly proved by Sir John Lubbock and others. The bodies of some bees, and the legs of others, are so admirably adapted for the collection and carriage of pollen, that it is almost impossible for them to visit any flower in pursuit of honey without bearing away a large quantity of pollen grains. The body of the humble bee (*Bombus terrestris*) is the best adapted for pollen-carrying. Lepidoptera stand next in order of importance to bees as pollen-carriers. Their long proboscides enable them to drain nectaries which less favoured insects cannot reach. The despised wasp is not without its use as a fertilising agent; for, according to Mr. Darwin, "if wasps were to become extinct in any district, so would *Epipactis latifolia*."

Honey, I need scarcely say, is the principal object of attraction to bees, butterflies, moths, and many other insects which assist in the work of fertilisation. It is secreted by specialised organs known as nectar glands. "In the flower," according to Dr. Goodale, an eminent American botanist, "these glands consist usually of specialised parenchyma, not unlike the secreting surface of the stigma." "Nectar glands," continues the author, "may occur in any part of the flower, upon its bracts, or upon some part of the flower-stalk near it. From the nectar glands of proper floral organs the secretion of nectar is generally copious, and is prone to collect in minute cavities, such as shallow pits, or in conspicuous special receptacles, the so-called nectaries. The period of most copious secretion of nectar usually coincides with the maturity of the anthers or of the stigma." Here we perceive another of Nature's beautiful contrivances for carrying out her purposes. Just at the time when the pollen is ready to do its work of fertilisation, or the stigma to receive it, a copious supply of honey both attracts and rewards the insect pollen-carriers.

The odours of flowers must be classed amongst the most potent attractions of insects. White flowers are more generally fragrant than those of any other colour. As examples of the accuracy of this proposition, I would refer to those delicately scented flowers, the Lily of the Valley, the Jasmine, and the Butterfly Orchis. I cannot do better than quote the words of Mr. Darwin in explanation of this:—"The fact of a large proportion of white flowers smelling sweetly may depend in part on those which are fertilised by moths requiring the double aid of conspicuousness in the dark, and of odour. So great is the economy of Nature that most flowers which are fertilised by crepuscular or nocturnal insects emit their odour chiefly or exclusively in the evening."

I have ventured to call attention to a comparatively large number of important facts, and for the purpose of giving my authorities have quoted largely. If these quotations have the effect, as I trust they may, of directing attention to, and inducing a perusal of, the works referred to, this paper will not have been written in vain. It will naturally be asked, Why has Nature planned all these contrivances to bring about cross-fertilisation? Mr. Darwin has clearly proved that plants which are the product of cross-fertilisation are both stronger in constitution and more prolific in seed-bearing, than those resulting from close-fertilisation. Another and more important result may have been designed, namely, the origin of new varieties and new species. If we consider how much the skilled nurseryman has effected, within living memory, in the direction of producing new varieties in such well-known plants as Roses, Strawberries, Pelargoniums, Primulas, and a host of other flowering and fruit-bearing plants, we may readily understand how pollen-carrying insects may, in the countless ages that have passed, have been instrumental in effecting changes of a similar character in plant development.

### CHRYSANTHEMUM SHOWS.

#### LONDON CORN EXCHANGE.—NOVEMBER 1ST AND 2ND.

THE first of the metropolitan shows was held in a room of the London Corn Exchange on Tuesday and Wednesday last in aid of the Corn Exchange Benevolent Society. Prizes ranging from £2 2s. to 5s. were offered in nine classes for cut blooms, and it is stipulated in the schedule that all blooms, whether in competition or not, should be sold by auction on the second day. With the admission fees and the proceeds of the sale a substantial amount is usually realised, thus since 1883 the total has ranged from £13 to £27. A Rose show is also held in the summer on the same principle, which since 1875 has been very successful, the amount in one case (1883) reaching as much as £64. The shows are held under the management of Mr. Henry Robins, the courteous Secretary of the Corn Exchange, who deserves much credit for the successful results. The date fixed this year, owing to the late season, was fully a week too early, and many exhibitors were unable to enter; still the blooms that were shown were extremely good, especially those presented by Messrs. Davis & Jones, Camberwell. Successful exhibitors

with Japanese varieties were Mr. Cyrus Legg, Selhurst Road, South Norwood; Mr. H. Shinder, Epsom; Mr. A. B. Lambert, Streatham, and Mr. A. Margetson, Streatham. The incurred were not so fine, several of those named gaining prizes. Other exhibitors were Messrs. J. Spiers, Tottenham Park; A. Fowkes, Northampton; Wickham Jones, South Norwood; Robert Pim, Streatham; Claude Bennett, 16, Mincing Lane; J. Westwood, Wanstead; John Aste, Norwood; O. Hodge, Chislehurst, and N. Sherwood, Esq., who sent a tasteful basket of *Chrysanthemum* blooms. Miss Percy and Mrs. Robinson also had handsome bouquets of blooms, the former's all white varieties, the latter's bronze and yellow.

#### SOUTHAMPTON.—NOVEMBER 1ST AND 2ND.

CONSIDERING the late season, it was feared the date would be too early, but a capital Show was provided. Cut blooms made quite a good display, while the quality in the Japanese blooms was excellent. The competition in all the Japanese classes was keen, as many as 550 Japanese blooms were staged. Fruit, as it always is at this Show, was of good quality. Vegetables were extensively staged and of very fine quality. Table plants, Palms, and groups for effect were of the best character.

CUT BLOOMS.—With twenty-four blooms, twelve Japanese and twelve incurred, nine competed. First, Mr. Woodfire, gardener to J. P. Boyd, Esq., J.P., Emsworth House, Havant, showing *Triomphe de la Rue de Chalets*, Madame C. Audiguier, Thunberg, M. Astorg, Princess of Wales, Lord Wolseley, and Novelty, very fine; second, Mr. J. Trinder, gardener to Sir H. Mildway, Dogmersfield Park, with large blooms a trifle coarse; third, Mr. C. Penford, gardener to Sir F. Fitzwygram, Leigh Park. For twenty-four blooms, not more than two of any one sort, Mr. W. Neville, gardener to F. W. Flight, Esq., Cornstiles, Twyford, Winchester, was first with full solid blooms of Japanese and incurred; second, Mr. Wm. S. Woodfire, whose Japanese was of capital quality; third, Mr. G. Inglefield, gardener to Sir T. N. Kelk, Tedworth, Marlborough. Ten competed. For twelve incurred blooms three only competed. First, Mr. J. Snow, gardener to J. Bruce, Esq., South Park, Wadhurst, Sussex; Messrs. W. & J. Drover second. For twelve Japanese Messrs. W. & J. Drover, The Nurseries, Fareham, were easily first with a fine stand of full solid blooms, Carew Underwood and Fair Maid of Guernsey were the best; second, Mr. Penford, with fresh blooms. There were thirteen entries. For twelve *Anemone* varieties Messrs. Drover were again first, a close second being Mr. Woodfire. Eight entries. For twelve reflexed, first, Mr. Woodfire, with good medium-sized blooms; second Mr. Wildsmith, gardener to Lord Eversley, Heckfield, Winchfield. In other classes for those not having won prizes and those debarred from showing in former classes there was brisk competition and good produce.

For the best group of *Chrysanthemums* in pots, space 8 feet by 6 feet, Mr. S. Busby, gardener to F. Willan, Esq., Thornhill, Bitterne, was first for dwarf, clean, well flowered, and neatly arranged plants. Second Mr. T. Osborne, gardener to H. J. Bachan, Esq., J.P., Wilton House, Southampton. For six incurred or reflexed, first Mr. Wakeford, gardener to G. Harris, Esq., Alder Moor, Shirley. For six Japanese, first Mr. Wakeford, 5 feet over, freely flowered, smallish blooms. Single specimen Japanese was best shown by Mr. E. Wills, gardener to Mrs. Peace, The Firs, Basset—i.e., Lady Selborne. Mr. Wakeford was second with a large plant of Madame B. Rendatler, with small flowers. For the best incurred or reflexed Mr. Wills was first with Dr. Sharp, Mr. Wakeford second with Mrs. G. Rundle. For the best group of miscellaneous plants arranged for effect, 12 feet by 7 feet, first Mr. J. Reynolds, gardener to Col. the Hon. H. C. L. Crichton, Netley Castle, with a bright arrangement of flowering seasonal plants. Second Mr. G. Wills. The best group of Orchids was staged by Mr. Osborne, very choice varieties.

Table plants and Palms were staged by Mr. C. J. Waite, gardener to the Hon. Col. Talbot, Glenhurst, Esher, and Mr. J. Reynolds. *Solanums*, *Poinsettias*, and *Primulas* were staged well.

FRUIT.—For three bunches of Grapes, distinct varieties, Mr. Hall, gardener to Captain Davidson, South Stoneham House, with Alicante, Barbarossa, and Muscat of Alexandria, all well finished, but rather small in berry; Mr. E. Molyneux, gardener to W. H. Myers, Esq., Swanmore Park, Bishop Waltham, being a close second with Alicante and Barbarossa, first. Third Mr. H. W. Ward, gardener to Earl Radnor, Longford Castle. For three bunches of black Grapes Mr. Molyneux was easily first for Barbarossa, averaging 5 lbs. each, well coloured, of good shape. Mr. Hall was second with Alicante, finely finished. Mr. C. Curtis, gardener to J. S. Dixon, Esq., Holly Bank, Hythe, being third. For three bunches of white Grapes, Mr. J. Chalk, gardener to G. Reed, Esq., Westwood, Wilton Road, Salisbury, was first, his Grapes being good in quality. Second, Mr. T. Hall, with two bunches black Grapes. Mr. C. Warden, gardener to Sir F. Bathurst, Clarendon Park, Salisbury, was first with Alicante in good condition. Second, Mr. T. Osborne. For the same number of bunches of white Grapes, Mr. W. Sanders, gardener to J. East, Esq., Loystock House, Stockbridge, was first. Second, Mr. C. Penford. For the heaviest bunch of Grapes, first, Mr. Ward with Gros Guillaume, weighing 9 lbs. 15 ozs. Second, Mr. Molyneux, with the same variety, weighing 8 lbs. 14 ozs. For one Pine Apple Mr. Wildsmith was first, and Mr. Ward second.

For four dishes of Apples, distinct, first Mr. Saunders with large finely coloured fruits. Second, S. Goodwin, Esq. For three dishes of dessert Apples, distinct, first Mr. Wildsmith with King of Pippins, R. boston Pippin, and second Mr. Goodwin. For three dishes of kitchen Apples, first Mr. Saunders, second Mr. Hall. For four dishes of Pears, distinct, Mr. Saunders first, General Todtleben and Pitmaston Duchess very fine; second Mr. Wildsmith, also fine. For three dishes of Pears, first Mr. Saunders; second Mr. A. W. Rooke, gardener to W. Gascoigne Roy, Esq., Byans, Machwood.

Vegetables.—For a collection of six varieties, first Mr. E. Molyneux, all in capital condition; Mrs. G. Busby second, also good. For the best collection of six varieties the prizes given by Messrs. Sutton & Sons brought seven competitors. First Mr. J. C. Waite with splendid produce; Mr. Pope, gardener to Earl of Carnarvon, Highclere Castle, Newbury, was second, with very fine produce; third Mr. G. Inglefield; fourth Mr. Saunders.

Mrs. M. Smout, scavenged florist, 8, Trinity Street, Hastings, had a first-class certificate for specimens arranged for table-decoration, ballrooms, flowers, &c. First-class certificates were awarded to Mr. F. W. Flight for a new seedling Japanese *Chrysanthemum* Bertha Flight, a full flower, long drooping florets of a pale blush or pink colour, very promising; and to



Messrs. W. & G. Drover for a new Japanese variety of the Comte de Germiny pattern of form and petals, very pale creamy lilac, striped and margined with a deeper shade of rosy lilac.

Mr. W. Colchester had a stand of Icthemio guano, &c; Messrs. W. Wood & Sons, Wood Green, London, also had a stand of their Orchid peat, and artificial manures. Very fine specimens of Mangolds grown on the Portwood Sewage Farm were shown, and Messrs. R. Smith & Co., St. John's Nursery, Worcester, had 60 dishes of Apples, all the leading sorts, finely coloured, and of excellent quality.

### CHRYSANTHEMUM SHOWS.

The following are the dates of the principal shows to be held during the coming months, at which Chrysanthemums will be the leading feature:—The figures following the name of the place at which the shows are to be held indicate the number of days devoted to the exhibitions, and it will be seen that a large majority are two-day shows.

#### NOVEMBER.

Thursday, 3rd ...	Havant (2) Henfield (2)	Tuesday, 15th ...	Watford (2) Finchley Southend (2) Winchester (2) Putney
Friday, 4th ...	Leicester (2) Crystal Palace (2)	Wednesday, 16th	York (3) Birmingham (2) Faversham (2) Birkenhead Northampton (2) Ealing Dartford (2) People's Palace (4)
Monday, 7th ...	Surrey (2)	Thursday, 17th	Chelmsford Bury St. Ed- munds (2) Chiswick Hull (2) Barnsley (2) Taunton Colchester Wimbledon Bolton (2)
Tuesday, 8th ...	Royal Horticul- tural Society Brighton (2) St. Neots Highgate (2) Kingston (2) Bath (2)	Friday, 18th ...	Sheffield & West Riding (2) Reading Chorley (2) Ramsbottom Monday, 21st ... Wolverhampton (2)
Wednesday, 9th	Croydon Weston - super - Mare Westminster (2) Ascot (2) Cornwall (2) Portsmouth (2)	Saturday, 19th ...	Bedford (2)
Thursday, 10th ...	Brixton (2) Walton Ipswich (2) Weald of Kent (2) Dawlish Hitchin	Monday, 21st ...	Eccles (2)
Friday, 11th ...	Canterbury (2) Huddersfield (2) Street (2) Lewisham (2) Sheffield & Hal- lamshire (2)	Tuesday, 23rd	Live-pool (2)
Monday, 14th ...	Twickenham	Friday, 25th ...	
Tuesday, 15th ...	Southgate (2) Lincoln (2)	Tuesday, 29th ...	

#### DECEMBER.

Thursday, 8th, Alnwick.

flowers ought to be kept as dry as possible. Those in pots should be moved into a dry airy pit or house to form their pods. We never found Kidney Beans sown about this time a profitable crop, as they do not make much progress in December and January, and as the cook salted a large quantity of pods from the runners for midwinter use, we will not try to force more after our present supply is exhausted.

**ROOTS FOR WINTER.**—Nothing gives more satisfaction in the kitchen in winter than a good supply of Carrots, Turnips, Onions, Carrots, Beetroot, Salsafy, and Parsnips. Onions keep best in a dry cool place; Carrots and Beetroot should be drawn up, and after cutting the leaves off pack them in moderately dry sand, leaf soil, or ashes, safe from wet and frost. They should only be stored when dry, and if packed in with the crowns protruding it will prevent many of them decaying. Turnips that are still growing may be left, but any large bulbs that might decay soon in the wet should be taken under cover. Do not bury them, but merely put them in a heap and throw a little straw over them. Parsnips and Salsafy are very hardy, and are better left in the ground. We only take up a quantity when we see indications of a long spell of frost.

**LATE PEAS.**—These have not been very successful this season. We gathered what may be our last dish on October 24th. The variety was Ne Plus Ultra, but they were sown during the hot weather, and were much scorched before rain came. They have retained the marks of this until now, as the lower part of the haulm is quite brown and withered. Very early Peas are a more certain crop than very late ones, and those who wish to extend the Pea season as far as possible should give extra attention to the first crops.

**OLD VEGETABLES.**—At this time of the year there are always many decayed vegetables in the kitchen garden. Peas are mostly over, Kidney Beans quite past, and other vegetables have become useless. There is no gain in allowing them to remain, and the best plan is to clear them all away. We do not approve of trenching this refuse in until it is partially decayed, and if it can be mixed with leaves and other refuse before returning it to the soil it will be all the better for the succeeding crops. Save the best of the Bean and Pea sticks, and burn the decayed ones, but do not clear away any green tops of Cabbages, as before very long every green vegetable may be in demand.

**CELERY.**—Although the season has not been one which is generally regarded as favourable to Celery this crop is good. The excessively dry weather did not cause many of the plants to bolt, but it prevented their making too luxuriant a growth, and the result is solid compact plants. The whole of the winter crop may now be earthen up another stage, and as this will be the last earthing for many rows it is a good plan to finish the top of the ridge and round the plants with finely sifted ashes, as these do not cause the plants to decay so much as soil in damp or frosty weather. It is early yet to begin to protect it from frost, but should it come very severe sprinkle a little fern or straw over the plants.

**FORCING RHUBARB.**—Our next notes will be mainly devoted to forcing, but as Rhubarb roots are the first to become ready for this operation they may be taken in hand at once. The leaves having died the most prominent crowns should be selected for the first crop. We do not advise their being lifted at this season, but if a cask with one end out, or a large box is turned upside down over the crown, and then form a good hotbed of fermenting manure of leaves over it and well round it, the young growths will spring up in a very short time. One good bed will force it to maturity, but the box or cask should not be completely shut in, as if the steam cannot escape from the interior it may cause the young growths to decay, and this should be avoided by having a little ventilation.

### FRUIT FORCING.

**FIGS.—Early-forced Trees in Pots.**—If these have been placed in the open air they should be taken under cover to protect them from the cold autumn rains. It is presumed that the trees have been top-dressed, repotted, or had the drainage rectified, as advised in a former calendar. The trees should be placed in a rather dry well-ventilated house. Any thinning or shortening crowded attenuated growths should be attended to, and the trees dressed with an insecticide—8 ozs. softsoap to a gallon of water may be used for washing the trees, using a somewhat stiff brush, especially if scale has been present, following with the same, to which sulphur has been added, to bring it to the consistency of cream, being careful not to damage the points of the shoots and the embryo fruit. A dish of forced Figs early in the season is now considered a necessity in large establishments, and is not by any means difficult to obtain, but a light well-ventilated house is necessary, with the command of plenty of heat, having pits containing fermenting materials to afford bottom heat to stimulate the roots. The Fig in pots requires abundance of liquid manure when growing, the trees being most prolific under limited root space. One of the great advantages of Fig culture in pots is the number of varieties that may be grown in a house of moderate dimensions, and which if forced early come in at a time when the dessert is not too varied. Brown Turkey is unquestionably the best Fig for general purposes, and the best white is White Marseilles. The following are also well suited for forcing and pot culture:—Osborne's Prolific, Early Violet, Black Ischia, Brown Ischia, Violette de Bordeaux, Negro Largo, Angelique, White Ischia, Col di Signora Bianco, and Royal Vineyard.

**VINES.—Early-forced Vines.**—Those for affording ripe Grapes in April must now be started, whether they be in pots or planted out. Bottom heat in neither case is indispensable, though in all forcing



### KITCHEN GARDEN.

**THE WEATHER AND THE CROPS.**—Until very recently the weather has remained dry with us. About the middle of October the water supply had sunk as low as it was in the warmest and driest part of the year, but vegetation did not suffer so much, and the cold dewy nights have kept plants fresh. Still, autumn crops have not grown as we have seen them, and an early winter would be much against many of them. Vegetables may yet be scarce, and any produce that is likely to go to waste should be used first. Brussels Sprouts are now well in, but there is little danger of their being spoiled, and although some might be inclined to use them, they may be kept until other vegetables are used that may be destroyed by the winter. Only use the large leaves of Spinach and allow all half-grown ones to remain to gain size.

**BRUSSELS SPROUTS.**—The bottom leaves of these are decaying, and if allowed to remain on and hang down over the sprouts they will cause many of them to decay. It is therefore a good plan to examine them, taking all the dead and decaying leaves, but do not remove any of the green ones or the tops, as these assist greatly in sheltering the sprouts.

**KIDNEY BEANS.**—We have been gathering many tender pods from a late sowing, but 8° of frost on October 25th blackened the plants, and our open air supply is over. Others in frames which have been covered at night are just beginning to bear, and those who took our advice some time ago and sowed seed in their vacant frames will still have acceptable gatherings. Seed sown in pots have produced plants which are showing signs of flowering, and they will succeed those in the frames; but damp is a great enemy to Kidney Beans at this season, and the foliage and



operations it hastens growth considerably; therefore place fermenting materials in the pit in which these in pots are stood on pedestals of loose bricks, being careful not to allow the heat about the pots to exceed 70° to 75°. Suspend the canes in a horizontal position over the fermenting material to insure a regular break. Syringe three times a day, keeping every part of the house moist by sprinklings in bright weather. Vines started at this season require a higher temperature to excite the buds than those started later. A temperature of 50° to 55° at night and 60° to 65° by day will not be too much to start with. Those planted out should have the border inside thoroughly soaked with water or liquid manure at 90°. The border or floor of the house should, if convenient, be covered 2 feet deep with leaves and stable litter in a state of fermentation, occasionally turning the material, as the ammonia given out is very beneficial to the Vines. The outside borders must be attended to; if fermenting materials are not obtainable cover with a good thickness of leaves, with tarpaulin, shutters, or lights to throw off rain or snow.

*Houses for Starting in Decemb r.*—Complete the pruning as it promotes rest. In pruning two eyes are ample for affording useful bunches, but Vines that do not afford bunches as large or so freely as desired should be allowed more buds, four to six, according to their vigour; yet with the wood stout and short-jointed the close pruning will mostly afford the most satisfactory results, as what is gained in size of bunch is lost in size of berry, compactness of bunch, and good finish. A good useful bunch of well-coloured, thoroughly ripened Grapes is always appreciated, therefore aim at that, as size, whether of bunch or crop, is quite secondary. Dress the Vines, cleanse the house, having all in good order ready for a start at the proper time.

#### PLANT HOUSES.

*Hardy Azaleas.*—The Ghent and Azalea mollis varieties intended for early forcing may be lifted at once, and placed in suitable pots according to their size. If plenty of pots are available, the whole stock of plants intended for winter and spring forcing may be safely potted now. When the whole of the plants are lifted those not required for some time may be plunged outside in a convenient position ready for introducing to the various fruit houses as they are cleared for starting, or into other structures in which they are eventually to be brought forward. Our practice has invariably been, after potting the earliest, to lift the remainder ready, and lay them in for potting in succession as the pots utilised for Chrysanthemums become vacant. No advantage is gained by crowding houses with those required for spring flowering, for they are just as well outside, provided the pots are protected from frost by ashes or leaves. Rhododendrons may also be lifted and treated in the same way, as well as other hardy evergreen flowering shrubs.

*Liacs.*—Those that have been plunged in pots may now be lifted from the soil, and all the roots that have extended over the edge and out of the base of the pots may be cut away. Those needed for early work should be left outside until they have been subjected to a good frost, which sends the plants quickly and completely to rest. By subjecting these hardy plants to early frosts they start afterwards quickly and freely into growth without reverting to undue measures. Young stock should be potted at once for next year's supply of plants, or those that were forced late in the season may be pruned back closely, potted if they need it, or top-dressed with rich material, and plunged in an open sunny position. If these operations are performed early, the plants will make a capital growth next season and give little or no trouble in watering. Those that are lifted, if the foliage is still fresh upon them, should not be pruned before the leaves fall. This will give them a chance of making a few fresh roots before the approach of winter. To be certain of having good flowering growths another year it is necessary to restrict the plants at their roots, for they are liable, especially Charles X., to make growths too strong to ripen sufficiently to set flower buds.

*Guelder Roses.*—The best plants from the stock potted last year should be selected for forcing, and the remainder cut close back. It is much better to rely upon plants prepared in 5 to 7-inch pots than to lift large bushes for forcing. This can be accomplished by striking cuttings every year either from young wood early in spring or from ripened wood at this season of the year. If strong one or two-year-old plants are lifted and potted at once in the sizes named, and then plunged, a good number of plants of a suitable size for decoration will be the result another autumn. Primroses may also be lifted and potted. It is a mistake to lift these plants and force them a month or two after they are potted. This system is certain to ruin the constitution of plants, or injure them to such an extent that they are useless again until the second or third year afterwards.

*Deutzias.*—With the exception of a few young plants lifted every autumn the whole of these plants are kept in pots. Young plants may be lifted and placed in 5 and 6-inch pots according to their size, and then plunged in ashes outside. They should be liberally syringed to preserve the foliage as long as possible, and then they will be partially established before winter. As soon as the foliage has fallen they should be pruned close back and plunged in cold frames, and if brought forward gently in spring they will make early growth ready for forcing moderately early in the season. If the plants from the general stock that have become weakened by forcing have the old soil shaken from their roots and repotted in fresh, and then treated the same as advised for young plants above, they will thoroughly recruit themselves in a season and make excellent plants. If this system is followed periodically the whole stock can be kept in admirable condition.

*Lily of the Valley.*—These, Spiræa japonica, and other similar plants used for forcing should be potted without delay, and those with small crowns planted for the next season's supply of plants. After potting, the whole of these plants are better outside than in until they have been exposed to a good frost.

#### THE FLOWER GARDEN AND PLEASURE GROUND.

*Evergreens and Conifers for Flower Beds.*—Flower beds, especially when situated near a dwelling house, unless filled with plants of some kind, present a very dreary appearance, and even when nothing but spring-flowering plants are used they are far from being attractive during the winter. Moreover, in many instances the Wallflowers, Forget-me-nots, Silences, Saponarias, Limnanthes, and other biennials and perennials are at their best when many families are migrated to town. The style of planting that usually gives the greatest satisfaction includes ornamental evergreens, bulbous rooted and spring flowering plants, and if well carried out the effect is good from the commencement. It is somewhat expensive, especially at the outset, all but the biennials and such perennials as Alyssums, Arabisis, Aubrietias, Violas, Iberises, Primulas, and Polyanthus having to be purchased. Some of the principal nurserymen prepare a variety of Conifers and evergreens specially for the decoration of the flower beds during the winter, and early in November is a good time for transplanting all and any of them.

*Selections of Suitable Plants.*—Any of the variegated Aucubas are effective, especially in large beds, and we have also largely used variegated Hollies of sorts, those about 2 feet high being very effective, no great difficulty being experienced in transplanting them either now or in May. The gold and silver variegated Box are of very accommodating habit and look well, while the gold and silver variegated Euonymus are still more effective. Euonymus radicans variegata is a showy edging plant, serviceable alike during winter and summer. The tree Ivies (Hedera arborea), both golden and silver, and Vinca elegantissima are very showy, while plants of Yucca recurva are most ornamental, and well adapted for the centres of small beds filled with dwarf plants. Mahonia aquifolia, Myrtle-leaved Portugal Laurel, and even neat plants of common Laurel, may be employed freely when large beds have to be filled. Of flowering shrubs the most serviceable are the dwarf or herbaceous Ericas, Andromeda floribunda, Kalmia latifolia, Laurustinus, Ligustrum japonicum, and Rhododendrons daphnoides, myrtifolium, ovatum, and Wilsoni. Berried plants of Skimmia japonica, Cotoneaster microphylla, and Pernettyas in variety are also very ornamental. The best effect, however, is often produced by a liberal employment of dwarf Conifers, notably Cupressus Lawsoniana erecta viridis, lutea, nana glauca, Cupressus nutkaensis, Cryptomeria elegans, Juniperus tamariscifolia, Retinosporas erieoides, obtusa aurea, nana, plumosa, plumosa argentea, squarrosa, and plumosa aurea, Taxus baccata elegantissima, and Thujaopsis dolabrata. These Conifers can be had in a very dwarf state and most suitable for planting in panels or neat designs, and a few about 2 feet high or less are attractive when dotted among flowering plants. A well planted bed would look well throughout the summer, all being amenable to pruning, and may, therefore, be kept in good form for several years. If preferred they may be removed in April or May, and if properly attended to will be available for the beds again when required. The coarser evergreens may be planted in mixture or in rings or panels as preferred, and if not planted thickly the effect will be further enhanced next spring if Narcissi and Hyacinths are interspersed among them. The front or margins of these beds ought to be covered with dwarf ornamental foliated or flowering plants, among which dwarf Tulips, Crocuses, Snowdrops, and Scillas may be distributed.



#### HINTS FOR BEGINNERS.

##### FIXING COMB FOUNDATION IN SECTIONS.

In a recent number of this Journal I described the simple plan of suspending sections to the top bar whereby any number can be wrought on a hive in one compartment, thus putting the bees on the best footing to make the greatest weight in the least time, and providing the bee-keeper with the cheapest system of management. I now supplement the above by adding that comb foundation can be fixed in sections without more labour than dropping the guide into saw cuts in the centre of the upright portions of the sections. This plan is very handy when bees are situated at a distance from houses or workshops, such as when they are at the moors, for neither instrument nor melted wax are necessary.

Should the bee-keeper find that the honey gathered by

the bees can be extracted and that a portion of it is desirable, this system gives him an opportunity of working for sections and extracted honey from the same hive at the same time. It can also be done with less cost and trouble than by any other system.

#### HONEY STRAINER.

After a good extractor or presser nothing is more essential than a good honey drainer, which also serves as a jelly strainer, and to be convertible into other useful household utensils. We have one composed of boxes with their sieves which serve many useful purposes, and the boxes hold jars, while they can be used as seats. One serves as a small press, while another is convertible into a capital meat safe. Its panels of perforated zinc are portable, and moveable shelves hold honey or other preserves. It stands about 41 inches high by 20 inches square; uppermost is a common sieve 18 inches in diameter, the honey is first poured into that and then passes into a milk pan 2 inches larger than the sieve and on which the latter rests. The bottom of this shallow milk pan has a hole about an inch in diameter, which is opened or closed by a sluice at will. The honey passes from this pan into another sieve of a finer work and wholly of wire cloth, standing also inside a smaller milk pan, which has also a hole and sluice. A third may be used if necessary. A muslin tapered bag suspended by hooks right beneath the lowest pan completes the arrangement, and nothing is more cleanly nor gives more satisfaction than this kind of drainer, as any portion can be examined without disarranging or interfering with another, and the whole thing is inexpensive.

#### THE WEATHER.

The weather, after fully two weeks of a night temperature ranging between 20° and 25° Fahrenheit, suddenly changed to a mildness of 63° in the shade on the 27th October. The pleasant change was welcomed alike by bees and bee-master, enabling the young unflown of the former to take a cleansing flight, and return to their hives in safety. The mildness did not come a day too soon, and the colonies will be all the better, it enabling them to withstand subsequent severe weather and come out more healthy at the close of winter than they would had the favourable opportunity not occurred.

As the mildness had an enlivening effect upon the bees, so did it act upon myself, and for the first time for some weeks did I attempt to have my bees well secured for the winter. It was late enough, seeing they had stood nearly bare but dry during the whole time of the cold—an unavoidable mistake, but rectified by prompt action the first mild day. Single-cased hives are either well packed between the hive and outer case, as well as on the top, or are wrapped on the sides with sacking covered by an apron of felt, and a good layer of soft material on the top, fully protected by a curved sheet of galvanised iron. The double-cased ones have it only on the top, and every colony occupies a full sized hive filled with combs. The custom of confining bees to as little space as they can be crammed into during winter I cannot commend, and those who advocate the system have much to learn.

#### SYRIAN BEES.

Syrian bees still give me much cause for reflection, and those people who have had an opportunity of studying these insects, but neglected it, have lost much that is interesting. At the end of July I divided an old stock of Syrians after it had swarmed into four nuclei. The fully filled honeycombs were removed, leaving ten large sized

frames to be divided amongst the four. One had one comb, a second had two, a third three, and the fourth four. The last mentioned two I manipulated on the 27th, transferring the frames and bees from single to double-cased hives, and to my astonishment I did not observe a single empty cell. Notwithstanding the lateness of the season, no less than six frames were tolerably well filled with brood in all stages. Five others were sealed to the floor with honey, and both hives are much alike in all respects. I added a twelfth frame, and made all snug for the winter. One of the four missed fertilisation, and the other has been strengthened with bees from a Carniolian—it being pure will be kept for breeding purposes for another season. These cases give a fair idea what the Syrian bee can do. Taking everything, and the state of these nuclei into consideration when sent to the Heather, they have far outstripped every other hive both in honey gathering and breeding. Whether so much late breeding will tell against the colony should a severe winter occur remains to be seen, but in their present state nothing could be more promising.

#### THE DISTANCE BEES FLY.

I have been much interested with the articles by "A Hallamshire Bee-keeper," particularly that part speaking of the distance bees fly for honey. I quite agree with him in opposing the idea or assertion that bees do not fly more than two miles. I have written much upon the distance bees fly, and the absurd views of those who say bees do not fly more than two miles. The present year my bees stood amongst fine Heather, yet at times they flew over it, and were seen gathering honey at a higher altitude by a thousand feet than where they stood, and at a distance of nearly three miles bee flight. Between the shores of Arran and the "Holy Isle" is a distance of three miles, yet the bees cross regularly, and when situated a long distance, too, from the shore. Lately, in the house of a clergyman I saw and tasted sealed Heather honey, gathered by bees nearly four miles from the nearest point on which Heather grew, and I have witnessed my bees often at a distance of nearly four miles working upon the Heather. When the Ligurian bee was first introduced here I saw numbers of them lying in a grocer's window, three miles fully from where the hives stood. I have never searched for bees further from their hives than the distances stated, but I have known a few bees and many drones return from a distance of nine miles. We have it on record where black bees were standing seven miles from Ligurian stocks that the queen of one was crossed by an Italian drone. I could cite many cases of bees being seen five and six miles from where they stood.

Doubtless bees fly longer distances than two or three miles either, but the question that affects us bee-keepers most is, not how far far bees can fly, but how far from their stands will they gather honey abundantly, or rather how far can bees be stood from their field of labour before they show signs of a diminution of honey. At a distance of between one and two miles from the Heather I have witnessed hives gather as much as those amongst it, but while this happened at one end of the moor, at the opposite one bees similarly situated were a long way behind.

When bees are a little distance as a mile or so from the Heather during fine weather I have noticed no appreciable difference in the quantity gathered from those nearer it, but during showery and squally weather those situated nearest it had the advantage. A mile or two for a bee with an empty bag is no great task for

a bee to fly; the disadvantage is not in the distance, but in the time of gathering the honey, or in the homeward journey. A heavily laden bee contending with adverse winds and a long distance is more likely to be lost than one within easy flight between the hive and forage ground. The distance bees can be situated from their field of labour without showing signs of less honey being gathered than those close to it has long engaged my attention; but while I find some say that bees are better to be situated at least a mile from it, the greatest evidence says as near as possible.

For my own part I am unable to answer the question, but I am of the opinion that the nearer the bees are situated to their labour the better; still I consider that half or even a whole mile from there will not diminish the yield of honey. If the question could be answered in a satisfactory manner it would be a great boon to many. As yet it is problematical, and there are few bee-keepers caring about making the experiment. I know this, I have in some seasons seen a quantity of Heather honey gathered by my bees at a distance of three miles from the Heather, while in others (and it was more often the case) not a cell. Now, taking these things into consideration I think most will agree with me, "A Hallamshire Bee-keeper" not excepted, that the nearer bees are situated to their labour the better the chances are that more honey will be gathered than at a distance if greater than a mile.—A LANARKSHIRE BEE-KEEPER.

### THE TERM OF A BEE'S LIFE.

#### NUMBER OF EGGS LAID BY A QUEEN.

In reading "Lanarkshire Bee-keeper's" recent "Essay on Bees" I noticed some statements which seem to require some explanation, and I would be greatly obliged by your giving me that explanation. You say, "I never fail to have bees every year in June that were hatched the May and June previously." What is your proof that the working bee will live a year or more? I have seen what seemed to me proof to the contrary. You say also in addition to the foregoing there are other wonderful phenomena, such as the almost "continued activity of queens in depositing 3000 to 4000 eggs in twenty-four hours." The accumulation of bees at that rate would be enormous, especially if they live a year—viz., 90,000 to 120,000 a month. What becomes of them, and how can a hive contain them? I have for a great number of years taken a deep interest in bees, and a reply to the above queries will be esteemed a great favour.—A. T. F.

[My proof is what I have said in my essay. There is no difficulty whatever in recognising bees a year old when a queen of a different breed has been introduced to a queenless colony during August or September, and which bees could not be hatched later than June, and if of a sufficient number many survive until the next May or June as stated. I have other proofs I could adduce, but which are unnecessary, more particularly as you withhold "proof to the contrary." Not knowing the evidence you can bring forward in support of your theory, I do not care to occupy more space than is necessary. The fact is, whatever proof there may be as to the life of the bee, it will only stultify the other argument regarding the number of eggs a queen can deposit in twenty-four hours. I have witnessed a queen and the eggs she laid during that time, which numbered not less than 6000. This is, perhaps, more astonishing than the modest number of 3000. But then you say the hive will not hold them, but hives are not all of one size. There is a very important factor which may be brought into this argument which I have never heard mooted by any writer on bees, and which tends to keep the great accumulation of bees in check—viz., more bees die or are lost at all seasons between the ages of ten and twenty days than when older. At the present moment a number of my Syrian stocks have much brood in all stages. Now, I am certain that more aged bees will be alive in June than young ones. The more aged bees are, until their wings become ragged, the more vigorous they are.

As to the number of eggs a queen lays in twenty-four hours, there is no difficulty in ascertaining, and as little in answering. I have times without number examined hives containing about 80,000 square inches of comb containing eggs and brood in all stages.

Now, as every inch of comb contains fifty young bees, there would be upwards of 70,000 eggs and young bees in their various stages. Now, all these eggs were laid within twenty days, which would be deposited at the rate of from 3000 to 4000 daily, and I have witnessed much larger breeding space filled with brood. I could say much more on this question, but think sufficient has been said until we hear your arguments against well substantiated facts.—LANARKSHIRE BEE-KEEPER.]

### TRADE CATALOGUES RECEIVED.

J. P. Williams & Brother's, Wilhelm's Rhue, Heneratgoda, Ceylon.—List of *Seeds of Tropical Plants and Commercial Products*.  
William Etherington, Swanscombe, Kent.—*Select List of Chrysa the-mums*.



## TO CORRESPONDENTS

All correspondence should be directed either to "THE EDITOR" or to "THE PUBLISHER." Letters addressed to Dr. Hogg or members of the staff often remain unopened unavoidably. We request that no one will write privately to any of our correspondents, as doing so subjects them to unjustifiable trouble and expense.

Correspondents should not mix up on the same sheet questions relating to Gardening and those on Bee subjects, and should never send more than two or three questions at once. All articles intended for insertion should be written on one side of the paper only. We cannot reply to questions through the post, and we do not undertake to return rejected communications.

**NAMING FRUIT.**—The attention of senders of fruit to be named, is respectfully directed to the intimation near the foot of page 395.

**Size of Stands for Exhibition Chrysanthemum Blooms (T. W. L.).**—The rule adopted by the National Chrysanthemum Society is the following: "Exhibitors are required to have their stands made in accordance with the metropolitan plan—viz., stands for twelve blooms to be 24 inches long and 18 inches wide, with holes 6 inches apart from centre to centre, to stand 6 inches high at back, and 3 inches in front. Two 'twelve-boards' may be used for twenty-four blooms. The six-stands to be the same width—viz., 18 inches by 12. All stands to be painted green, and to have the supports secure. No limit as to size of board in any classes where Japanese blooms are exhibited."

**Doyenne du Comice Pear (M. C. B.).**—You may safely plant the trees, this excellent variety succeeding well in this country where the soil and position are favourable for the growth and ripening of Pears. It is recorded in the last edition of the "Fruit Manual" that the tree is a healthy grower and a very good bearer. It forms handsome pyramids on the Quince. Mr. R. D. Blackmore, writing from Teddington, says, "This is, to my mind, the best of all Pears; very healthy, a certain cropper, of beautiful growth, and surpassing flavour. I have grown it to the weight of 14 ozs. on heavily cropped trees. But on a wall it is far inferior." Writing from the Weald of Sussex, Mr. Luckhurst, of Oldlands, says, "It is a most delicious Pear, very sweet, rich, melting, and juicy."

**Fruit Trees on Walls (An Amateur).**—As the trees that were planted last autumn "made no wood, and were troubled a good deal in the summer with ants," we suspect insects were permitted to infest the leaves and arrest growth. Ants do not as a rule trouble trees that are free from insects. All that can be done is to shorten the branches to a wood, not a fruit bud, and mulch the ground over the roots with manure, and the trees may possibly start growing in the spring. Any incipient growths that may be found on the branches may be cut back to buds at the base. If there is scale on the branches dress them with soft soap and petroleum or other approved insecticide; and in the spring adopt timely measures to prevent insects attacking the young growths and expanding leaves; permitting them to get encrusted with aphides, then having recourse to strong insecticides for their destruction, is an excellent way to prevent them from growing.

**Roses for Wall (C. B.).**—You do not indicate whether you live in the north or the south, or whether you require rambling growers or choicer sorts. The following are good, producing beautiful flowers when well grown:—Gloire de Dijon, Reine Marie Henriette, Belle Lyonnaise, Cheshunt Hybrid, Maréchal Niel, the Waltham Climbers, Nos. 1, 2, and 3, William Allen Richardson, Climbing Devonensis, Souvenir d'un Ami, Rêve d'Or, climbing Victor Verdier, climbing Capitaine Christy, Celine Forestier, Madame Joseph Desbois, Solfaterre, Blaire No. 2, and Fulgens. Planted at equal distances they will cover the wall.

**Heating a Small Greenhouse (N. S. R.).**—As you wish to exclude frost with the least trouble in stoking we should have a small apparatus heated with gas, which we understand you have in your dwelling house. You will not find the cost of a small pipe for conveying it very serious. If you prefer, you can have the boiler you name to be heated with coke and small coal; but this would require more attention, and perhaps at times when it would be inconvenient. A flow and return 3-inch pipe along the front of the house, if it is a lean-to, would be ample, without the pipes being overheated, involving the consumption of much fuel.



**Flowering Plants for Shrubbery Border Infested with Rabbits** (J. S.).—The best of all are Rhododendrons, and we should use them as the principal evergreen. Azalea pontica (Ghent and English varieties), also A. mollis vars., Mahonia aquifolium, and the different varieties of Ribes are not particularly relished. Lilacs are somewhat nibbled, but Guelder Rose escapes, and so do most of the Spiræas. Sweet Briar is good, and so are Deutzia scabra and D. crenata flore-pleno. Cotoneaster Simmondsi is not seriously attacked, and the Syringas (Philadelphus) are allowed to grow, whilst Weigela escape scot-free. Hypericums are not much damaged, nor is Berberis Darwini. Dogwood and Elder, the Golden being very effective, also Double Gorse are very suitable. Spurge Laurel is not eaten by rabbits. The difficulty is at first planting. After the plants become established the Rabbits seem to care less for them; but anything fresh they set upon with remarkable zest.

**Walks for Kitchen Garden** (F. J. B.).—A good sound walk can be made with coal tar or gravel, or preferably with ashes and coal tar, having granitic siftings for the surface to insure its wearing better. The way to proceed is to bring the walk to within 3 inches of the intended surface with rubble—i.e. brickbats or similar material, giving the necessary incline, and putting any drains, with their cesspools and gratings at the proper level, the walk being made precisely as if it were intended to finish with a coat of fine gravel. The ashes need only be sifted through a three-quarter-inch screen, so as to rid them of the coarser material. They should be dry, and being placed on a hard bottom be made into a mortar-like mass by pouring boiling coal tar into a hole in the centre, and mixing thoroughly. The walk having a somewhat smooth level surface spread on the asphalt evenly, and beat down firmly after having sprinkled it with half-inch granite chips. When sufficiently firm roll so as to form a close mass and even surface. When dry, which will depend on the weather as its attaining sufficient firmness to admit of traffic over it, you will have a first-rate walk that will last a lifetime. Granite siftings make a capital walk, having them dry and made into a mortar-like mass with boiling coal tar.

**Constructing Pinery** (Ferndale).—You confine us to a length of 10 feet. Such a structure is too small for anything save a supply of Pines occasionally, which may be all you require. The site should be free from stagnant water lodging within 3 feet of the ground level, and have the advantage of every ray of light. The aspect for the house should be south. A three-quarter span would be the most suitable, having the house 10 to 12 feet wide, with the pathway at the back. We should make an excavation below the ground level 2 feet deep, and have the front wall 4 feet 6 inches high, and the back about 6 feet. The roof lights may have a slope of about 1 foot in 3 feet of width. Side lights are not necessary; wooden ventilators immediately under the front wall plate, about 2 feet by 1 foot in every alternate light, with a similar width—i.e. a foot at the apex and on the south side the whole length of the house—will afford sufficient ventilation. The side walls should be taken up 9 inches thick to within four courses of bricks of their height, and then 4½ inches, the last being built in cement. This will form a ledge in front, on which there should be two rows of 4-inch pipes, and other two will be needed at the back, but they should be in the path and on a similar level to the front ones. Those will be necessary for top heat. By having a 4½-inch wall to form the side of the bed about 2 feet 6 inches from the back wall, and the height of the front wall to the ledge, you will have a bed about 3 feet 6 inches deep for tan to afford bottom heat, and you can have hot-water pipes covered and surrounded by rubble, or have them in a chamber covered with wood slabs, slate, or flag, whichever method you may think most applicable to your convenience. The front roof lights should be moveable, so as to be raised or removed as required for cultural requirements.

**Re-grafting Pears** (N. E.).—Your proposed plan is an excellent one, as in the course of a few years very satisfactory results may be looked for. Of the very early Pears is Rivers' St. Swithin, which is of medium size and not unlike Jargonelle. Clapp's Favourite is large and handsome, having a better constitution than Jargonelle. The old Windsor is not despicable as a market Pear; then comes Williams' Bon Chrétien and Madame Treyve. Louise Bonne of Jersey is capital where it succeeds, also Fondante d'Antonne, but it is only of medium size and will not keep. Beurré Hardy is good, but does not bear freely in a young state. Of the large Pears Gregoire Bourdillon, Pitmaston Duchess, and Durondeau are good. Doyenné du Comice is in every respect excellent. In some localities Marie Louise does remarkably well, and where it does not Marie Louise d'Uccle may be tried. It is large and good, and generally bears when others do not. We have only named those of which we have experience, and on that account we recommend them.

\* The publication of this and the two preceding replies has been delayed through an irregularity in the post.

**Names of Fruits.**—The names and addresses of senders of fruit to be named must in all cases be enclosed with the specimens, whether letters referring to the fruit are sent by post or not. The names are not necessarily required for publication, initials sufficing for that. Only six specimens can be named at once, and any beyond that number cannot be preserved. (T. B. Q.).—1, King of the Pippins, very fine; 3, the same variety small; 2, Nonesuch; 4 and 6, not recognised; 5, Cox's Orange Pippin. (Fritton).—1, Vicar of Winkfield; 2, Brown Beurré; 3, not recognisable; 4, Knight's Monarch; 5, Charles Van Mons. (J. C. C.).—Pears: 1, Doyenné du Comice; 3, Beurré Diel; 4, Duchesse d'Angoulême. We do not think the seedlings possess any merit. Apples: 3, Yellow Bough; 6, Margil. (W. J. G.).—1, Doyenné Blanc; 3, Altho'pe Crasanne; 4, Green Yair; 5, too brimised for identification. The Apple is Margil. (W. M.).—1 and 2, not recognisable; 3, Tom Putt; 4, Golden Noble; 5, Dumclow's Seedling; 6, Hambleton Deux Ans. (G. T.).—1, Beurré Diel; 2, Catillac; 3, Glen Morçeau; 4, Maréchal de Cour; 5, Napoleon; 6, Beurré Rance. (Maud Cave).—Marie Louise d'Uccle. (J. Udale).—1, not recognisable, inferior; 2, Annie Elizabeth; 3, Claygate Pearmain; 4, probably local, worthless; 5, Gilgil; 6, Wyken Pippin. N.B.—In consequence of Dr. Hogg's absence from London, fruit cannot be named by him till after the middle of November.

**Names of Plants.**—We only undertake to name species of plants, not varieties that have originated from seed and termed florists' flowers. Flowering specimens are necessary of flowering plants, and Fern fronds

should bear spores. Specimens should arrive in a fresh state in firm boxes. Slightly damp moss or soft green leaves form the best packing, dry cotton wool the worst. Not more than six specimens can be named at once. (Juvenis).—1, Montbretia Pottsii; 2, Ophiopogon spicatum variegatum; 3, not recognisable; 4, Cassia corymbosa; 5, Clematis Flammula; 6, too imperfect, but apparently a Lonicera.

COVENT GARDEN MARKET.—NOVEMBER 2ND.

BUSINESS in an unsettled state. Prices unaltered.

PLANTS IN POTS.

	s. d.	s. d.		s. d.	s. d.			
Aralia Sieboldi, dozen	6	0 to 13	0	Fuchsja, dozen	6	0 to 9	0	
Arbor vitæ (golden), dozen	6	0	9	0	Geranium (Ivy), dozen	0	0	0
" (common), dozen	0	0	0	0	" Tricolor, dozen	0	0	0
Asters, dozen pots	0	0	0	0	Gladiolus	0	0	0
Azalea, dozen	0	0	0	0	Hydrangea, dozen	9	0	12
Begonias, dozen	4	0	9	0	Lilias Valley, dozen	0	0	0
Capsicums, dozen	0	0	0	0	Lilium lancifolium, doz.	0	0	0
Chrysanthemums, dozen	4	0	13	0	" longiflorum, doz.	0	0	0
Cineraria, dozen	0	0	0	0	Lobelia, dozen	0	0	0
Dracæna terminalis, doz.	30	0	60	0	Marguerite Daisy, dozen	6	0	12
" viridis, dozen	12	0	24	0	Mignonette, dozen	3	0	6
Erica, various, dozen	9	0	18	0	Mnsk, dozen	0	0	0
Euonymus, in var., dozen	6	0	18	0	Myrtles, dozen	6	0	12
Evergreens, in var., dozen	6	0	24	0	Palms, in var., each	2	6	21
Ferns, in variety, dozen	4	0	18	0	Pelargoniums, dozen	0	0	0
Ficus elastica, each	1	6	7	0	" scarlet, doz.	3	0	9
Foliage Plants, var., each	2	0	10	0	Spiræa, dozen	0	0	0

CUT FLOWERS.

	s. d.	s. d.		s. d.	s. d.			
Abutilons, 12 bunches	3	0 to 6	0	Lilies, White, 12 bunches	0	0 to 0	0	
Anemones, 12 bunches	0	0	0	" Orange, 12 bunches	0	0	0	
Arum Lilies, 12 blooms	6	0	9	0	Marguerites, 12 bunches	2	0	6
Asters, 12 bunches	2	0	6	0	Mignonette, 12 bunches	1	0	3
" French, bunch	0	0	0	0	Myosotis, 12 bunches	0	0	0
Bouvardias, bunch	0	6	1	0	Narciss, 12 bunches	0	0	0
Camellias, blooms	3	0	6	0	" White, English, bch.	0	0	0
Carnations, 12 blooms	1	0	2	0	Pansies, 12 bunches	0	0	0
" 12 bunches	0	0	0	0	Peas, Sweet, 12 bunches	0	0	0
Chrysanthemums, 12 bchs.	6	0	12	0	Pelargoniums, 12 trusses	0	9	1
" 12 blooms	1	6	6	0	" scarlet, 12 trusses	0	4	0
Cornflower, 12 bunches	0	0	0	0	Poinsettia, 12 blooms	0	0	0
Dahlia, 12 bunches	0	0	0	0	Primula (single), bunch	0	0	0
Daisies, 12 bunches	2	0	4	0	" (double), bunch	0	9	1
Encubaris, dozen	6	0	8	0	Polyanthus, 12 bunches	0	0	0
Gardenias, 12 blooms	2	0	5	0	Ranunculus, 12 bunches	0	0	0
Gladiolus, 12 sprays	1	0	1	6	Roses, 12 bunches	0	0	0
Hyacinths, Roman, 12					" (indoor), dozen	1	0	1
sprays	1	6	2	6	" Tea, dozen	1	6	3
Iris, 12 bunches	0	0	0	0	" red, dozen (French)	1	0	2
Lspageria, white, 12					" yellow	0	9	1
blooms	1	6	3	0	Stephanotis, 12 sprays	4	0	6
Lspageria, coloured, 12					Tropæolum, 12 bunches	0	0	0
blooms	1	0	1	6	Tuberose, 12 blooms	0	6	1
Lilium longiflorum, 12					Tulips, dozen blooms	0	0	0
blooms	6	0	9	0	Violets, 12 bunches	1	0	1
Lilium lancifolium, 12					" (French), bunch	1	6	2
blooms	1	6	3	0	" (Parme), bunch	5	0	6

FRUIT.

	d.	s. d.		s. d.	s. d.			
Apples, ½ sieve	1	6 to 3	6	Oranges, per 100	6	0 to 12	0	
Nova Scotia and				Peaches, dozen	2	0	6	
Canada barrel	0	0	0	Pears, dozen	1	0	1	
Cberries, ½ sieve	0	0	0	Pine Apples, English,				
Cobs, 100 lbs.	65	0	50	per lb.	1	6	2	
Figs, dozen	0	0	0	Plums, ½ sieve	0	0	0	
Grapes, per lb.	0	6	2	6	St. Michael Pines, each	3	0	5
Lemons, case	10	0	15	0	Strawberries, per lb.	0	0	0
Melon, each	0	6	1	0				

VEGETABLES.

	s. d.	s. d.		s. d.	s. d.			
Artichokes, dozen	1	0 to 2	0	Lettuce, dozen	0	9 to 0	0	
Asparagus, bundle	0	0	0	Mushrooms, punnet	0	6	1	
Beans, Kidney, per lb.	0	3	0	0	Mustard and Cress, punt.	0	2	0
Beet, Red, dozen	1	0	2	0	Onions, bunch	0	3	0
Broccoli, bundle	0	0	0	0	Parsley, dozen bunches	2	0	3
Brussels Sprouts, ½ sieve	3	6	4	0	Parsnips, dozen	1	0	0
Cabbage, dozen	1	6	0	0	Potatoes, per cwt.	4	0	5
Capsicums, per 100	1	6	2	0	" Kidney, per cwt.	4	0	0
Carrots, bunch	0	4	0	0	Rhubarb, bundle	0	2	0
Cauliflowers, dozen	3	0	4	0	Salsafy, bundle	1	0	1
Celery, bundle	1	6	2	0	Scorzoner, bundle	1	6	0
Coleworts, doz. bunches	2	0	4	0	Seakale, basket	0	0	0
Cucumbers, each	0	4	0	6	Shallots, per lb.	0	3	0
Endive, dozen	1	0	2	0	Spinach, busbel	0	1	6
Herbs, bunch	0	2	0	0	Tomatoes, per lb.	0	4	0
Leeks, bunch	0	0	3	0	4	0	6	
					Turnips, bunch	0	4	0



PROGRESS.

We were making a Michaelmas farm valuation recently, and a discussion of the table of costs prepared for our guidance by a certain estate agents' society led to the remark that "Such guidance was undoubtedly useful, but after all much was left to the judgment of a valuer."

It is just so in agricultural education; for however well grounded a young man may be in theory, practical experience must be had to enable him to effect any real improvement, and to obtain results at all superior to those obtained by the ordinary practitioner. That improvement is possible we know full well, and we may go farther and insist upon it that farm crops may be so improved as to render them really profitable.

Take for example Wheat, of which we are told by a very high authority that the average yield throughout the country is under 30 bushels an acre; yet we have both White and Red Wheat yielding fully 40 bushels an acre, and we know a farm where the yield ranged as high as 56 bushels an acre. Why is there so much difference? it may be asked. A sound practical answer is given by two Wheat ears lying beside us as we write. One is 2½ inches long, the other fully 6 inches in length, with straw almost as large as our penholder. Careful selection of a pure sample of seed goes very far to insure a paying crop; without such care it were far better to give up growing Wheat at all.

We certainly do not agree with the sweeping assertion that Wheat-growing does not answer and must be discontinued in this country. Rather would we continue to devote a fair proportion of all suitable land to it, and at the same time take good care to do all that is possible to rear animals for market. There can be no doubt that is a sad want of energy in this matter. We are told that the number of home-fed cattle sold in the London cattle markets has decreased from 55 to 49 out of each 100 animals submitted to the salesman. The proportion of sheep has declined from 71 to 45 in each 100 sold, and pigs have gone down from 76 to the miserably small number of three out of each 100 swine sold. In striking contrast to this falling off in the numbers of home-reared animals is an account of the beef and pork trades of Chicago in the *Times* of October 21st. We are there told that "The hog is regarded as the most compact form in which the Indian Corn crop of the States can be transported to market. Hence the corn is fed to the hog on the farm, and he is sent to Chicago as a package provided by Nature for its utilisation. A ride out among the rows of wooden buildings still existing by the square mile in the southern suburbs, as if to tempt another great fire, leads to the Union Stock Yard. The extensive enclosure is a town of itself, with its own banks and hotel, 'Board of Trade,' post office, town hall, and special fire department, the latter being a necessity, as it occasionally has very destructive fires. About £400,000 has been invested in this undertaking, which covers nearly a square mile, a large part of it being cattle pens, through which lead eight miles of streets, and having sufficient capacity to accommodate 200,000 animals at one time. A scene in this place is most animated, the cattle men riding about on horseback driving their herds, while adjacent are the immense 'packing houses' that prepare the pork and beef for market. During the past twelve months these establishments have killed and packed 4,426,000 hogs, and 1,608,000 beeves, their product going to all parts of the world. This represents a very large proportion of the whole number of these animals in the States which are fatted to kill, for at the opening of this year it was estimated that there were in the country, of hogs of all ages, 44 millions, and of cattle, exclusive of milch cows, 33 millions. The products of the packing reach enormous figures, being no less than 1,055 millions of pounds of pork and lard for the year, and 573 millions of pounds of dressed beef. A very large proportion of the pork

and lard, 810 millions of pounds, were exported beyond the States, and of this 90 per cent. went to the United Kingdom. The packers say their hog trade does not increase, but their beef trade grows at an extraordinary rate."

When are we to hear it said in this country that the hog is a package provided by Nature for the utilisation of cheap corn? Nothing can be more deplorable than the mismanagement of pigs in this country. Filth and improper food bring swine fever, which spreads over the farms near, quickly leading to serious losses. It will be a true sign of progress when the management of pigs has the care and attention its importance merits. In any attempt at reform in this matter the value of oatmeal for fattening pigs must not be overlooked. Oats are not worth more than half the value of grinding Barley to sell or buy, yet the intrinsic value of the two sorts of corn as fat and flesh formers is almost equal.

(To be continued).

#### WORK ON THE HOME FARM.

The collection and storage of Mangolds is now in hand. Most farmers have put off doing this as late as possible, owing to the vigorous growth of the crop throughout October, and such growth was much wanted where the roots were backward and small. Where silage has taken the place of roots there must be a considerable saving effected, but the makers of Maize silage have had that useful crop much cut up by early frost. We have seen several fields of Maize with all the upper portion of the plants browned by frost. We shall put no Swedes in clamps this autumn, for the roots are so small and compact that they will be better left on the land, unless there are special reasons for a clearance before spring. We have had to take large quantities of farm-yard manure in valuation, and Wheat sowing was at once followed by carting all such manure upon the land for Barley and Peas. It will at once be spread and ploughed in, and the land so left in readiness for the spring corn. This is not strictly according to routine practice, but expediency has much more weight with us than routine. We wish to get as forward as we can with all the land to be cropped next spring, because we have much foul land to grapple with next season. Where there is no ploughing in of manure ridging will be done, as it tends to expose the soil well to the action of the weather, and it is harrowed down for spring sowing fine as ashes, and the sowing may usually be done much earlier than if the land were not ridged. Of the foul land, that which is heavy may have to be kept for a long summer fallow; that which is light or good mixed soil may be cleaned soon enough for a root or green crop. If it can be had for green crops it may be enriched by ploughing in of a crop or two, and so be brought into a condition of fertility for the following season. We might say that foul land and failure go hand in hand, for whenever a farm is thrown upon our hands by the failure of a tenant, we have always to contend with its foulness and poverty. We hold that it answers best to devote the first year to getting such land thoroughly clean, dry, and fertile. To do all this in a single season, however, demands a special effort; certainly any attempt at cropping would not answer.

MALTING BARLEY COMPETITION.—Messrs. E. Webb & Sons inform us that the sample which secured the champion prize medal for English-grown Barley at the Brewers' Exhibition was Webb's Kinver Chevalier, originally grown from their seed. There were forty-eight competitors.

#### METEOROLOGICAL OBSERVATIONS.

CAMDEN SQUARE, LONDON.  
Lat. 51° 32' 40" N.; Long. 0° 8' 0" W.; Altitude, 111 feet.

DATE.	9 A.M.					IN THE DAY.				Rain	
	Barometer at 32° and Sea Level.	Hygrometer.		Direction of Wind.	Temp. of soil at 1 foot.	Shade Temperature.		Radiation Temperature.			
		Dry.	Wet.			Max.	Min.	In sun.	On grass.		
1887.											
October.											
Sunday .....	23	30.316	41.2	40.8	E.	43.5	52.3	30.2	72.4	26.0	0.06
Monday .....	24	30.026	40.9	37.2	N.W.	43.7	45.1	30.7	79.4	36.2	—
Tuesday .....	25	30.510	35.3	33.0	N.W.	43.2	45.9	30.4	81.0	26.6	—
Wednesday .....	26	30.546	30.7	30.0	S.W.	42.2	48.3	25.4	77.4	23.2	—
Thursday .....	27	30.153	46.5	43.3	S.E.	41.9	52.5	30.2	64.4	26.3	0.112
Friday .....	28	29.747	52.4	52.1	N.	43.1	59.6	44.2	98.4	42.3	—
Saturday .....	29	29.711	50.3	47.9	S.	44.3	57.8	42.4	91.8	35.4	0.612
		30.144	42.5	40.6		43.1	51.6	34.6	80.7	30.9	0.736

#### REMARKS.

3rd.—Dull early; bright, pleasant day.  
24th.—Rain in small hours; fine cold day.  
25th.—Slightly foggy at times; otherwise bright and cold.  
26th.—Cold, with slight fog till 11 A.M., then bright.  
27th.—Dull, with occasional showers.  
28th.—Rain in small hours, dull and damp till about 10 A.M., then fine, warm, and bright.  
29th.—A lovely day, bright and warm; solar halo from 2 P.M. to 2.30 P.M. Rain in the evening. Gale at night.  
A fine bright week, nearly all the rain recorded having fallen at night. Temperature about 5° below the average.—G. J. SYMONS.



## COMING EVENTS

10	TH	Portsmouth, Brixton, Walton, Ipswich, and Dawlish Shows.
11	F	Hitchin, Canterbury, Huddersfield, and Lewisham Shows.
12	S	
13	SUN	23RD SUNDAY AFTER TRINITY.
14	M	Sheffield and Hallamshire Show. [Chester, and Putney Shows.
15	TU	Twickenham, Southgate, Lincoln, Watford, Finchley, Southend, Win-
16	W	York, Birmingham, Northampton, Ealing, Dartford, & Chelmsford Shows.

### CRINUMS.

**S**TOVE bulbous plants of an ornamental character are not nearly so abundant as those adapted for culture in greenhouses or similar cool structures, and nearly all the best of the bulbs available for the warmer houses, are included in the Amaryllis family, which also in the Narcissi affords such a wealth of flowers out of doors. The Amaryllises or Hippeastrums take foremost rank for size of flowers and brilliancy of colours, but they do not need strictly stove treatment, succeeding best in warm conservatories or "intermediate" houses. With them may be named the Imantophyllums which have been so greatly improved in recent years, and the useful Vallotas. The Eucharis, however, is an all-important plant in both private and market establishments, its white wax-like flowers being highly valued for wreaths and bouquets, and scarcely less esteemed are some of the graceful and fragrant Pancratiums. Both these are restricted to a few cultivated species, but in the Crinums we have a much larger number to select from, presenting a range of floral form and delicate tints that places them at the head of all stove bulbs.

Though the majority of Crinums are natives of tropical regions in the Old and New Worlds, some are found in districts of a much lower temperature, and from South Africa we have a few species which with their varieties and hybrids thrive well out of doors in the warmer parts of Great Britain. Both the indoor and outdoor groups are easily grown, flower freely, and when in their best condition are exceedingly beautiful, bearing great umbels of twelve to twenty flowers on stout stems rising from the bulbs. The leaves are mostly long, 2 or 3 inches broad, bright green, and rather fleshy, often gracefully arching over the bulbs 3 feet or more in length. The bulbs attain considerable size under favourable treatment, but we rarely see such numbers of flowers produced in cultivation as in their native state, for specimens sent home by botanists frequently have as many as forty flowers in an umbel, particularly of the stronger growing species. There is one disadvantage attending many of the Crinums, and that is the flowers are not very durable, nor do they produce such a succession of flowers as the Eucharises and Pancratiums. To compensate for this, however, they rarely miss flowering, and as the various forms naturally flower at different periods it is easy by growing a good election to have some in bloom during the greater portion of the year. The form of the flowers varies of large massive, funnel-shaped or spreading flowers, with broad divisions, the tube either short or long, and in the latter case often curved and more deeply coloured than the other portion of the corolla. Upon the characters furnished by the position of the flower—that is, whether it

be erect or curved—botanists found some of the groups in which the species are classed. Much difference is notable between the broad petalled Crinums and those which partake more of the Pancratium type, such as *C. Hildebrandti*, with long, narrow drooping divisions, and but for the absence of the characteristic corona of the Pancratiums they might be readily mistaken for one of them. White flowers preponderate, but there are numbers with delicate rose-tinted corollas, with rich rosy stripes down the centre of the divisions, rosy red tubes, and some even of a purplish crimson hue, especially amongst the *C. capense* hybrids. The fragrance, too, of numerous species is delightfully delicate, exactly of the well-known *Pancratium fragrans* style, not too powerful to displease the most sensitive, and yet so freely produced as to diffuse itself throughout a large house.

Referring briefly to the culture of the Crinums it may be well to deal first with those requiring stove treatment, or at least needing plenty of heat in their growing period. Bulbs are imported by the principal nurserymen of full flowering size, and they also grow on stocks from offsets or seed, so that purchasers can readily procure plants of almost any age to start with. The best soil for them in any stage is old turfy loam with one-fourth of leaf soil or peat, but any good substantial though not adhesive loam is suitable, with sufficient sand added to render it moderately porous. For well-established plants that are wished to flower vigorously a small portion of old manure can be incorporated with the soil, but as a rule any assistance needed can be better afforded by means of weak liquid manure. Many of the Amaryllidaceous and other bulbous plants are not benefited by placing manure in the soil to the same extent as might be expected. Some of the most successful growers of Amaryllises now exclude all such substances from the soil, employing instead only the best loam procurable. Where these plants, too, are plunged in old tan, it is surprising what vigorous growth the roots make in it. Crinums are moisture-loving plants during their growing period, and must therefore have a soil that will permit the free passage of water, with efficient drainage to prevent any stagnation. The pots must be proportioned to the size of the bulbs, but 10-inch pots will be found large enough for most flowering plants if the offsets are removed. Some prefer repotting the plants with their offsets, as the latter usually provide a succession of flowers, and one specimen may be thus had in bloom several times during the year; but if it is desired to increase the stock, and very large pots are not wanted, it is better to separate the offsets, and grow them on singly.

It is a rather tedious process raising Crinums from seed, as three or four years elapse before they reach flowering size even with the best management; it is therefore preferably left to the nurserymen. Still it is not difficult to obtain a stock of young plants in this way, and seed is readily ripened if the plants are in a sunny situation. Experimental and professional hybridists have taken full advantage of the facility with which crosses can be effected in this genus, and numbers of very interesting hybrids have been obtained, especially by Dean Herbert, who has given in his works lists of the crosses he secured and the results, many of which afford some curious evidence of the laws ruling cross-fertilisation. The seed must be sown in sandy soil in heat, and when the young plants are visible they should be pricked off singly into small pots, being very careful in the supply of water at these early stages. As they advance they can



be transplanted into larger pots, and about the third year they will require their largest size, when they will probably flower if they have much good growth.

A period of rest is necessary, but the plants should not be dried off to the same extent as some plants are treated. Encourage free growth, let this be well matured and the bulbs ripened by exposure to the sun, then the resting should consist in partially withholding water until the soil becomes dry, but not parched, so that either bulb or leaves suffer.

The hardy *Crinums* of the *C. capense* group are excellent plants for well drained borders of rich deep soil in warm districts, such as the South and West of England and Ireland. Provided there is no stagnation they may be planted near ponds or lakes, as they like plenty of water, but they are more liable to suffer during winter in such places. A warm, moist border where protection can be given during severe weather is the best suited for them, and if they are covered with a heap of dried leaves it will be sufficient in most cases, or a mat will answer the same purpose. Strong growing bulbs are often planted too near the surface of the soil, and *Crinums* should be at least 5 or 6 inches below the surface where the border is suitable. Travellers at the Cape of Good Hope have remarked how deep some of the numerous bulbs are found in a wild state, and have reasonably thought that failures in cultivation may often be traced to ignorance of this, especially as regards those in pots where a comparatively small depth of soil can be provided.

An enumeration of the *Crinums* known to botanists, or even to those alone which are grown in botanical collections, would require a series of articles, but a few of the most distinct and ornamental species may be noted. In extremely few private gardens would a dozen distinct *Crinums* be found, yet they might take the places of some other less beautiful occupants of our houses with advantage. Of the tropical species the following deserve especial note as worth addition to stove plants—*C. amabile*, one of the most handsome of the genus, an East Indian plant, introduced by Dr. Roxburgh in 1810. It is strong in habit, with umbels of twenty or more fragrant flowers, the corollas 9 inches long, with broad recurving white divisions having a central crimson line, and purple stamens, anthers, tube, and ovary. This has a grand appearance when bearing one of its large umbels.

*C. americanum* is a West Indian and South American plant with large flowers and bulbs, the former white, with spreading petals, and red stamens. *C. asiaticum* is another East Indian *Crinum*, its favourite habitat being at the side of rivers. It has an elegant appearance, the flowers being of good size with long narrow drooping white divisions, the filaments long, and tipped with red. The leaves are broad, and the umbel of considerable size.

*C. erubescens* is a South American species, but in general style it is suggestive of *C. Hildebrandti*. The flowers have long red tubes with long narrow white divisions, reddish filaments, and yellow anthers. The leaves are broad and furnished with a toothed cartilaginous edge, which distinguishes it from some selected species. *C. giganteum* is appropriately named, for in growth and size of flower it is the giant of the family. It is a native of Sierra Leone, whence bulbs were sent to the Marchioness of Rockhampton in 1792. The leaves are long and broad, the flower stems frequently 3 feet high, the corollas having tubes 9 inches long and 6 inches across at the mouth, white with a tinge of green on the external surface of the tube, the anthers being dark

purple. Owing to the breadth of the oval divisions the flower has great substance and a bold appearance.

*C. Hildebrandti* was discovered by the gentleman after whom it is named, Dr. Hildebrandt, in 1875, amongst the mountains of the Comoro Islands, at an elevation of 3000 feet. In the same year bulbs were sent to the Berlin Botanic Garden, but it seems uncertain whether any were then transmitted to England. Three years later, however, Dr. J. Kirk, in honour of whom the next species was named, rediscovered it in its native land, and forwarded bulbs to Kew, where it flowered in 1881. It has not become generally known, however, outside those gardens until Messrs. J. Veitch & Sons recently flowered it, and exhibited a plant at South Kensington (fig. 51, page 406). The leaves are, when fully grown, about 2 feet long; the flower stem is 1 foot or more high, with six to twelve flowers, pure white, the tube 6 inches long, the divisions narrow and drooping. The filaments are red and the anthers very dark, affording a striking contrast with the pure white of the other portion.

As showing two distinct types of *Crinums*, the figure of *C. Kirki* (page 407) may be compared with that of *C. Hildebrandti*. In this the flower has broad spreading divisions, white with a clearly defined central rosy crimson bar. It is free-growing and produces large umbels of flowers. The plant was introduced from Zanzibar in 1879, and was brought prominently into notice by Mr. B. S. Williams a few years ago, when it was certificated by the Royal Botanic Society at Regent's Park.

The principal hardy *Crinum* is *C. capense*, but of this there are numerous varieties, and by crossing with other species it has yielded several beautiful hybrids. It is sometimes seen under the name of *longifolia*, an old synonym, but quite obsolete now and very misleading, as there is a tropical species named *C. longifolium* quite distinct from *C. capense*. The latter has long, curving, funnel-shaped flowers, ranging in colour from pure white to purplish crimson. The leaves are long, and in habit the plant is strong, developing a large bulb. Three of the best varieties are *album*, pure white; *riparium*, purplish; and *striatum*, streaked with rose and white. With these must be named *C. Powelli*, a cross between *C. capense* and *C. Mooreanum*, which has proved quite hardy and free flowering in several districts. *C. Mooreanum* and *C. ornatum* have been successfully tried out of doors in a few warm sheltered situations, but they cannot be regarded as safe in most localities.—C.

## FACTS ABOUT GRAPES.

### GROS MAROC.

ALTHOUGH I have never yet written much in praise of Gros Maroc, quite the reverse in fact, I am bound to say it is sometimes to be met with in really first-class condition. Innumerable good examples, as far as appearance is concerned, have been forthcoming in all directions, but, with two exceptions, all I have tasted have proved of very poor quality indeed. We have it on a Black Hamburg stock in a second early house, and this rod perfected really grand bunches, each weighing about 3 lbs., but the flavour was very second rate. In a Muscat house on its own roots it was of very poor quality, and those bunches now hanging on a rod grafted on a Black Hamburg stock in late house are no better. This being the experience of others beside myself, I was the more agreeably surprised to find it when tasted recently altogether superior. At Hindlip, near Worcester, it proves one of the best and most pleasantly flavoured black sorts grown, being rich, yet not too much so, as sometimes happens in the case of good Black Hamburg. Added to this the bunches were of good size, the berries large, black as sloes, and carrying a good bloom. It is grafted on a Foster's Seedling, and Mr. Barker informs me it is invariably good on this stock.

Since I saw and tasted these a second eatable crop of Gros

Maroc has come under my notice, this time in quite a different direction—viz., at Gunnersbury House, near Acton. Here again it is worked on the Foster's Seedling stock, and Mr. Hudson, the well-known gardener in charge, says it is always similarly good in every respect with him. According to my experience with the practice of grafting and inarching Vines of one kind on a stock of a totally different character, no perceptible difference, either for better or worse, is to be noticed in the habit and quality of the inarched variety. We have Muscat of Alexandria on the Black Hamburgh, Gros Guillaume on the former and Black Hamburgh, Mrs. Pince and Alicante also on the Hamburgh, and in neither case is there any noticeable difference from those on their own roots. The Gros Maroc is naturally of rank-growing habit, and it may be the restraining influence of the less vigorous Foster's Seedling stock has the effect of checking grossness, an improvement in the quality also resulting. Foster's Seedling is not remarkable for the superiority of its fruit; at any rate it is inferior to the Black Hamburgh, and in many instances might well be changed for a longer keeping variety, such as Gros Maroc. The latter invariably sells well, and this cannot be said of any white sort other than Muscat of Alexandria.

#### BUCKLAND SWEETWATER.

In this district it is surprising how rapidly the Buckland Sweetwater is supplanting Foster's Seedling, this being mainly due to the rather undue partiality judges at flower shows have developed for it. When well grown and finished it certainly is the more handsome of the two, but when as at Taunton the preference is given to rather second rate examples when there are perfectly finished bunches of Foster's Seedling pitted against them, the judgment is decidedly wrong. As a rule exhibitors are not often in the habit of placing themselves second, but the shrewd exhibitor of the Buckland Sweetwater was agreeably surprised at being awarded the first prize. Foster's Seedling is no doubt more easily grown than Buckland Sweetwater, and in my estimation is the better Grape of the two. Neither ought to be grown very extensively, especially seeing that Lady Downe's, Alicante, Gros Colman, and Gros Maroc require very little, and in some positions no more fire heat to grow them to perfection. Moreover, the Alicante, Gros Maroc, and Mrs. Pince force capitally, and being of better appearance frequently realise much better prices in the market than any of the reputed early kinds.

#### MRS. PINCE.

It appears that Mrs. Pince is improved by forcing. Mr. Lewis Barnes, gardener at Collingwood House, Hawkhurst, Kent, invariably succeeds without hard forcing in ripening Mrs. Pince early in July, and has exhibited some of the best finished bunches I have yet seen. Exhibitors in the "any black class of Grapes other than Hamburghs" should take a note of this, especially if they fail to prevent cracking in the case of Madresfield Court. It would appear that there is every prospect of a much enlarged Mrs. Pince being shortly brought forward. In the vineries connected with the gardens at Hallow Park, Worcester, one spur on a rod of Mrs. Pince has developed for two successive seasons a bunch with berries fully double the size of those on the other bunches, and if the young Vines raised from the lateral retain this character we shall have yet another new variety in commerce. As far as I could see this extraordinary sportive bunch has set the berries evenly, and they have the square appearance denoting a fair complement of seeds. If it should prove to be as shy setting as its parent, or as in the case of the Canon Hall Muscat, even worse in this respect, it will be a pity for another disappointing sort to be distributed. A free setting extra large berried Black Muscat would, however, be welcomed on all sides.

#### ALNWICK SEEDLING.

I have tasted Alnwick Seedling in various parts of the country, but in no instance has the quality proved satisfactory. It is really a second rate Grape. Very few now fail to set the berries as evenly as Alicantes, and I have never seen them when ripe other than black. As far as habit and fruitfulness are concerned it is all that could be wished for; but there, however, its good qualities cease, as it is not even a good keeper. West's St. Peter's is altogether superior to it, yet we rarely meet with it, and I must also plead guilty to a reprehensible neglect of this good old sort. Mr. Hudson has long grown it at Gunnersbury House, and experiences no great difficulty in effecting a good set. It requires about the same amount of heat as the Alicante, and is grown in a mixed late house. It produces abundance of bunches, rather loose in character, while the berries are round, medium sized, quite black, crisp, and pleasantly flavoured. Mr. Hudson long ago discovered that invalids could eat this Grape when all others proved unpalatable, his experience being exactly identical with that of one of our greatest authorities on Grapes—viz., Mr. A. F. Barron.

#### LATE GRAPES.

Yet another note from Gunnersbury House. In the year 1878 Mr. Hudson planted a house with late Grapes, those intended to be permanent having an outside border all to themselves, while the supernumeraries were disposed in a narrow inside border or pit. The latter is about 3 feet deep and 20 inches wide, and was built close to the front wall. Both borders were built on the tank system—that is to say, are so constructed as to hold water in the case of its being necessary to flood out a second attack of phylloxera, with which Mr. Hudson has had an unwelcome experience. The inside and outside borders are not connected by means of an arched wall, but there are a few small drainage outlets at the bottom of the former. The supernumeraries alternated with the intended permanent Vines, and from the first proved quite as profitable; in fact, they have annually done so well that they are yet preserved. Lady Downe's, Alicante, and Gros Colman are the principal sorts growing in these narrow pits, and each on an average are carrying ten good bunches. An annual good top-dressing of loam and manure with abundance of water and liquid manure is what Vines in narrow borders need, and what they receive at Gunnersbury House. I could give other instances where excellent Grapes have long been grown in narrow raised borders, but sufficient has been stated to open the eyes of intending planters to the fact that a small well attended border is much superior to the usual large borders only partially occupied by roots.

#### BLACK HAMBURGH.

Few Grapes pay better for superior culture than the Black Hamburgh, and no other sort appears so amenable to all sorts of treatment. At Gunnersbury Park last year a house of this variety was ripened in April. After being rested for about six weeks they were started afresh, and actually ripened off a good crop by mid-winter. It is not to be supposed that Mr. Roberts ever thought the Vines would go on perfecting two crops in the year, this being too much even for the long-suffering Hamburgh. They were thus treated in order to get all that was possible out of them in a short space of time prior to clearing them out and replanting with different varieties. In March a number of pot Vines were planted in a narrow loamy border, and these have developed into some of the finest rods I have ever seen. All reached the top of the house, and many of them will be only lightly shortened. One cane selected at random measured 2 inches in circumference upwards of 12 feet from the roots, and all are very short-jointed with little pith, the wood being really as hard as it could well be. Strange to relate, one of the old Vines that was first cut hard back, both at the top and roots, and then planted with the young Vines, is nearly or quite as vigorous as the rest. If a good start has anything to do with it Mr. Roberts will eventually have some fine Grapes from those Vines.—W. IGGULDEN.

#### CHRYSANTHEMUM NOTES

##### SWANLEY.

ONE of the most remarkable characteristics of Messrs. Cannell and Sons' "Home of Flowers" at Swanley is the regularity with which a succession of special attractions is maintained throughout the year. At one time the houses seem full of Pelargoniums, at another the Primulas appear to occupy all available space. Verbenas and Tuberous Begonias have similarly special seasons when they engross all the attention of visitors, and now having reached dull November several houses are devoted to Chrysanthemums. Enormous numbers of plants are grown to afford the requisite supplies of cuttings to meet the annual demand, and it is always found difficult to obtain sufficient of such varieties as Lady Selborne, Refulgence, White Globe, and some others that are not very prolific of base shoots. A large space of ground outside has consequently been planted with a reserve stock, besides some thousands planted in borders under glass to yield early cuttings, and as a measure of safety in the event of severe frost. Beyond these three span-roofed houses are devoted to plants in large pots, grown to show the characters of the best varieties in all sections as well as the novelties which are now so abundant. The plants are dwarf, with large dark green leaves to the base of the stems, and there are numbers of fine buds that with favourable weather may be expected to develop satisfactorily. At present the display is chiefly confined to the earlier Japanese, and in one of the houses these form a beautiful bank of bright and varied colours. Amongst the novelties are those sent out by Messrs. Cannell & Sons early in the present year. These comprise the following, raised from imported seed—Lady Cave, Arthur Wood, Mrs. Castle, Mrs. B. Wynne, Mr. Matthew, and C. L. Teesdale; imported direct from Japan Mrs. H. Cannell, Mr. H. Cannell, Lady T. Lawrence, Lady Emily, Mr. Addison, Mr. H. Wellam, Shirley Hibberd, Edwin Molyneux, and Mr. C. Orchard. Few of these are as yet at their best, but the two last named, of the Comte Germain type, are very promising in several collections. It should be added in reference to these that special prizes of £10, £5, £3, and £2 were offered at the National Chrysanthemum Society's Show, Royal Aquarium, Westminster, November 9th and 10th, for the best twelve blooms of

these varieties. In announcing these prizes Mr. Cannell stated that they were to be judged by ballot—namely, each stand to bear a number only, small cards being sent to eighteen experts, who were requested to record upon these their decision, slipping the cards into a box, which was to be opened at 4 P.M. and the votes counted. Some doubts might be entertained as to the advantages of such a system at large exhibitions. On a few occasions it might be suitable, but much delay would be caused in making known the awards.

Beautiful as are the Chrysanthemums, their brightest colours pale in contrast with the brilliant Zonal Pelargoniums, of which there is grand display in several houses. In one the effect is strikingly rich, the white, pink, salmon, and scarlet tints being well proportioned and most tastefully arranged. There are several new varieties, but a quartette merit special notice—namely, Mrs. Cannell, a fine single white, with large beautifully formed flowers; Swauley White, a double variety of excellent habit, very free and pure; Goldfinder, a brilliant double scarlet, most floriferous and compact in growth; and Chameleon, one of the dwarf decorative type, bearing double flowers of numberless narrow petals, scarlet, pink, and purplish, most variable and distinct. It will be useful both for decorative purposes owing to its compact habit, and for cutting, as the blooms stand well. Large numbers of Primulas are making good progress, and promise a fine show later on, and there are besides hosts of other attractions in the various houses. Mr. Cannell has now found ample scope for his energies at his Eynsford nursery and seed farm, where he has over 300 acres under cultivation. A considerable portion of the land near the railway (the Sevenoaks branch from Swanley), is devoted to hardy plants, Pæonies, Pansies, and Violets being grown by acres. A selection of the most useful herbaceous plants is also included, and the soil evidently suits them. Other portions are devoted to vegetable seed growing. Some 20 or 30 acres have been planted with choice fruit trees, and the other part is at present devoted to pasture or ordinary farm crops. A seed store house of considerable size has just been commenced, and preparations for the first range of houses are also visible. The farm is situated in a very pretty portion of Kent, and within a few minutes' walk of Eynsford station.

#### FOREST HILL.

Just as the last flowers are fading of the Tuberous Begonias, and the outdoor roots have been housed, Messrs. J. Laing & Sons are preparing to devote some of their convenient houses to the Chrysanthemums. For some years past the show of these popular plants has attracted many visitors, and this season it is one of the most satisfactory yet obtained. A new departure has been made in growing the plants dwarf instead of allowing them to run up to what exhibitors regard as the normal height, but which amateurs often object to. When arranging plants for effect it is most difficult to make a decent display of these giants; and though fine blooms have great weight in competition, yet well finished groups are much more satisfactory, and a few dwarf well furnished plants in the front have secured many an exhibitor honours that would not have been otherwise obtained. Several good growers have also proved that substantial representative blooms can be produced on such plants with due attention to disbudding and liberal treatment at a suitable period. This also Messrs. Laing & Sons have proved, for their plants were stopped the third week in June, and the majority are now 3 to 4 feet high, bearing four or five good blooms each, the stems clothed with well developed foliage to the base of the stems. A few of the tall-growing varieties, which usually run up to 6 and 7 feet when grown unstopped, do not exceed 4 to 5 feet on the stopping system. The plants are grown in 9 or 10-inch pots, and though vigorous growth is encouraged no attempt is made to induce the grossness which some apparently consider essential to the production of fine blooms.

The chief show house is a span-roofed structure 100 feet long, with a low central and two side stages. The plants being arranged upon these are brought near the glass, yet the blooms can be conveniently seen when passing round the house. All the best varieties are represented, and the so-called continental novelties have also been tested this year, with the result that several are found to be synonymous with those sent out in previous years, and in several cases those really distinct are not superior to others already in cultivation. Last season Messrs. J. Laing sent out several seedlings raised at Forest Hill, and some of these have more than justified the good opinion previously formed of them. These were as follows, all Japanese varieties:—Agnes Flight, creamy white long florets; Album Fimbriatum, pure white broad fringed florets; Alpha, purplish rose; Evelyn, crimson; Mrs. J. Wright, pearl white (figured last week); Mr. D. B. Chapman, purplish crimson, long florets, cut at the ends; Mr. Stephenson Clarke, orange red, broad florets; Mr. W. H. Burbridge, creamy white; Rose Beauty, rosy lilac; and Stanstead White, a large bloom. Some of these, like Mrs. J. Wright, have proved very satisfactory this season. Alpha, Album Fimbriatum, and Mr. D. B. Chapman have also gained certificates at several shows. Album Fimbriatum we recently noted in promising condition at Morden Park, and Mr. Gibson has a very favourable opinion respecting its qualities. It would be an advantage to English cultivators if the practice of raising seedlings here was extended, as nurserymen in this country are compelled to exercise more discretion in sending out novelties than the continental growers.

Some of the most notable of the new and recent varieties are the following Japanese, the incurved not being quite out at present—Florence Piercy, white, narrow curled and twisted drooping florets, deep fine blooms from crown buds; Val d'Andorre, grand, richly coloured blooms, on plants 2½ feet high; Coquette de Castille, excellent blooms

on 2 feet high plants; Ornaments, deep red, gold reverse, not very large, but fine colour; Forester, broad flat florets, white flushed with purple, large, but rather thin; Duke of Berwick, narrow twisted florets, white, flushed with purple; and Lucien Baltet, purplish crimson, rich distinct colour, the florets broad and recurring. Other good varieties in flower are Madame de Sevin, Alexandre Dufour, Mr. Freeman, Mandarin, Madame Laing, Wm. Stevens, Comte de Germiny, Moonlight, Phœbus, Elaine, La Triomphante, Wm. Robinson, Madame Paule Dutour, Le Camoens, Bonnington, La France, Alfred Chantrier, Belle Paule, L'Or du Japon, and Theodore Bullier. The large Pompon, Elise Dordan, is also in excellent condition.

In the other houses there are the usual stocks of healthy stove and greenhouse plants, Orchids, &c., the Nash Court variety of *Lapageria rosea* having been an especial feature for some weeks past, its richly coloured flowers far surpassing any other variety in size and numbers.

#### STOKE NEWINGTON.

The Brunswick Nursery, Stoke Newington, now occupied by Mr. J. R. Chard, of "floral decoration" renown, was once widely famed for its Chrysanthemums—namely, when Mr. Forsyth was the ruling spirit. Specimen plants and blooms are not grown now, but some thousands of small useful plants for cutting, or employment in decoration, have taken their places. A house 120 feet long is devoted to compact dwarf plants in pots for a late display, as they are most in demand during December and up to Christmas. Handsome little bushy Pompons in 48-sized pots, now covered with blooms are very attractive and useful. Mr. Chard also has a large stock of Ferns, Pelargoniums, and miscellaneous bedding plants.

#### CHILWELL.

A long journey may be taken and a good deal seen and done in a day in these fast times. Leaving St. Pancras at 10 A.M., we are at Nottingham in two hours and a half, and another ten minutes' journey takes us to Beeston for Chilwell; we spend five or six hours there, and another equally good train brings us back to St. Pancras at 10 P.M. A run of about 250 miles and reporting a Chrysanthemum show is perhaps not a bad day's work; but "work" is scarcely the proper term, for a pleasant journey and a most agreeable reception at the end of it renders the day one of enjoyment rather than of labour.

Judging from the great array of plants in the splendid houses of Messrs. J. R. Pearson & Sons, Chilwell must be regarded as the great Chrysanthemum centre of the midland counties. A greater number of plants are grown by some of the specialists in the south, and more attention paid to disbudding and the development of individual blooms; but as a representative collection of plants, disbudded and otherwise, and the effect produced by them, in a span-roofed house 100 by 30, and about 15 feet high, this home exhibition at Chilwell must take very high rank amongst the best of the year. But though special attention has not been devoted to the production of a limited number of show blooms throughout the collection, it must not be supposed there are none, for undoubtedly both of incurved and Japanese varieties could be cut worthy of being arranged in stands at the best public exhibitions.

In the former section, perhaps, finer blooms of Jeanné d'Arc have never been seen. They are remarkable for their depth and solidity, while there is an absence of that roughness or bristliness which often mars the effect of this variety. Mrs. W. Shipman is in grand form, large enough for back row blooms in good stands, and unusually good in colour. It is questionable if finer examples have been seen of the variety. Lady Hardinge is above the average in size and depth, worthy of any stand. Prince Alfred, Lord Wolseley and Alfred Salter are also very good, and the Queen varieties promising, while Lord Derby is deeper and finer than it is commonly met with. Mr. Bunn and the Beverleys are also good, and there is a bloom of Arigena, also known as Inner Temple, that is not often seen equalled. It is prominent by its size and effective by its amaranth colour, but the florets of this variety are too short for incurving, and even a bloom like this would weaken a stand of good incurved flowers. There are other varieties showing well, but as a rule Japanese and decorative varieties preponderate, and a few more good examples of the incurved section would give weight to the bright and diversified collection.

Among the Japanese varieties the palm must be given to Wm. Stevens for brightness and effectiveness, handsome and elegant orange red blooms of it showing to great advantage. For size, substance, and general "build," also well coloured, Criterion is conspicuous, blooms of it equaling Mr. Tunnington's best productions, and perhaps no one has grown this variety better than he has. Madame Lacroix is represented in its best form, and must be regarded as one of the most constant and useful white varieties in cultivation. The newer Mrs. J. Wright, which Mr. James Douglas says is the best white yet raised, was not expanded, but the free growth and bold buds, seven or eight on a plant, characterised it as a "good doer," and that is what growers like, though the plant is too tall for low houses. It will be tried on the cutting-down system at Chilwell, then taking the crown buds; and if the "crowns" are a week later in consequence, that will probably be an advantage rather than otherwise, for southern shows at least, if not generally. Mr. Stevens' handsome blooms were too early for the shows, and so far as has been seen those from terminal buds are not large enough, yet charming for decoration. It is almost certain that the descriptions of varieties by a "Notts Grower," on page 287 last week, though Mr. Pearson is not the author of them, were taken from this collection; at any rate, they are very accurate, and it is therefore unnecessary to repeat them here. The beautiful new yellow Japanese variety, Mr. Garner, was flowering and



will be in request; the blooms this year (the first) are not quite large enough, but stronger plants another season will probably remedy that. Phœbus was in good form, with very clear yellow drooping florets, but they appear a little destitute of substance, and the blooms will probably not last long in beauty. The American Anemone variety Thorpe, jun., deep clear yellow, was admirably represented. Ordinarily its guard florets are too irregular, but one bloom from which some of them had been removed was compact and smooth enough for any stand; it was also large, with a good cushion, and worth at least five points out of six in counting.

It is found that many varieties are more useful at Chilwell when topped two or three times, then allowed to bear all the flowers they can without disbudding. In this way they are suitable for decorative effect, and affording a wealth of sprays for cutting. Alex. Dufour, L'Or du Rhin, Source d'Or, and some others, including the bright and new Roi de Précoces, cannot produce large blooms if disbudded, and these and the following will be grown as indicated next year. Sœur Melanie, Le Neige, Chevalier Domage, Tendresse, Embleme, Flambeau, L'Africaine, Bonquet Fait, Ville d'Heycres, William Clark, Rubra Perfecta, La Frissure, James Salter, Lady Selborne, Soliel Levant, and possibly some others. Apart from the display, which is now attracting numbers of visitors, another very large house is filled with late varieties, and it is quite certain that there will be no scarcity of Chrysanthemums at Chilwell from the present time till the middle of January, and probably later.

In visiting Chilwell it is impossible to overlook the Zonal Pclargoniums that are now a "blaze of beauty." For habit, freedom, quality, and colour, the varieties raised here are pre-eminent, and so far from the public tiring of them, the demand this year has been greater than ever. Nor is this surprising when we see such as Charles Mason, Sissy, Lord Tredegar, Mrs. David Saunders, International, and Lady Francis Russell; while of the old sorts for winter flowering Mrs. H. T. Barker and Charles Smith commanded attention. In others of the large house we find one devoted to Ferns and Vines, another to Stephanotis and Eucharis, a third to Vines in pots, very fine; a fourth to Camellias, a fifth to Maréchal Niel and other Roscs, a sixth to Camellias, and so to the number of over twenty; and in one vinery is a fruit exhibition, the Messrs. Pearson having offered prizes to collections grown north of the Trent, but they were not awarded when we left the Nursery. Time did not permit an inspection of the 20 acres of young fruit trees, nor the 100 acres of orchards, but a glance was had at what cannot be found elsewhere—2000 fine plants of the beautiful *Yucca filamentosa variegata*, established in the open nursery, and have never been protected even when the thermometer has fallen below zero. For rockwork and choice positions such plants as these would add a feature distinct from everything else and attractive.

#### TWO GOOD NEW CHRYSANTHEMUMS.

MANY Chrysanthemums have been introduced last year, especially from France, that are either old varieties under new names, as pointed out by Mr. Davis some time ago, or that are destined to a transient fame. Of those that seem most promising, La Triomphante and L'Ebouriffé, both raised by Reydellet, deserve to be specially noted. They are excellent contrasts. The former opens a lilac rose and gradually assumes a whitish pink; the latter opens a crimson-reddish orange, and finally becomes almost pure yellow; the former gracefully reflexed, while the latter is equally as good incurved. [The National Chrysanthemum Society, when they next issue an edition of their excellent catalogue, might divide the Japanese into reflexed, incurved, &c.] Both commenced blooming, from crown buds with me, the last days of October, and thus would evidently be good for all the earlier November shows; while with terminal buds, any day to the end of November. Both blooms would be large enough for show purposes, and are likely to be more largely grown next year. Of other new ones the tallest growing is Le Cid, while the dwarfest is Veitch's Fils, not reaching 18 inches in a 10-inch pot. I cannot speak for the quality of the blooms of those or others yet, but would suggest that growers give you an opportunity of publishing a list of dwarf-growing Chrysanthemums. They would be exceedingly useful for conservatory and other decorative purposes where the tall growing cannot be utilised. I should have noted in reference to La Triomphante that the foliage is similar to Lady Talfourd, Ariadne, and a few others. Distinguishing Chrysanthemums by their foliage is often important.

#### REFLEXED CHRYSANTHEMUMS.

This class is very limited, so I am sure all lovers of those will welcome the three new additions noticed at Messrs. Veitch's—viz., Alice Bird (Buttercup), bright yellow; Aspasia, pale satiny rose—this description resembles Emperor of China, one of the most useful, freest blooming, and hardiest Chrysanthemums in existence; and Irene, pale soft rose. As you have permitted me to make so many suggestions, the last would be that you give your readers a detailed description of those three when they are at their best.—W. J. MURPHY, *Clonmel*.

#### NORTHERN AND SOUTHERN GROWERS.

"W. D.," whether designedly or unconsciously I am unable to say, pays Mr. Molyneux a great compliment on p. 339 last week, for if he can by inspecting plants in September forecast with any substantial accuracy the character of the blooms they will develop in November he must be endowed with no ordinary mental power of penetrating into the future. The suggestion of his viewing the "nakedness of the land,"

and thereon calculating his chances of success in competition with the Liverpool growers, is not such as is heard from men who have won a high position as cultivators, for such men have no objection to anyone seeing their plants two or three months before a show, and they do not attribute selfish motives to any fellow gardener who may give them a call. But if that was Mr. Molyneux's object, why did he not report on the plants grown by Mr. Tunnington, who is one of the chief of the Liverpool growers? If he inspected those plants and kept silence about them he might lay himself open to suspicion; but if he did not see them, what becomes of the "impression" that "W. D." has recorded? If Mr. Molyneux called at Calderstone, or whatever the name of the place may be, it is fair to assume he would have reported on the plants there the same as on those at other places at which he called.

As to the "results" of Mr. Molyneux's teaching, have not they been seen by many experienced judges at many shows, and are not these judges as capable of estimating the character of his blooms as "small growers and beginners" are? If not, then the "beginners" ought to be the judges according to "W. D.'s" theory.

In reference to the old "North and South" controversy, and the relative capacity of growers, it is safe to say there are first-rate Chrysanthemum growers in both districts, and possibly not far wrong to surmise there are some of the other sort. As a southern grower Mr. Molyneux's record is known. What is the record of "W. D."? If through want of opportunities it should not happen to be quite so good, perhaps he can furnish the records of others who have won a greater percentage of first prizes in a given time than Mr. Molyneux has. A few "returns" of that nature would be interesting.

Possibly "W. D." knows that the best Liverpool growers have competed in the south, and lost and won prizes there, still they failed in the end to win the coveted cup at Kingston, excellent as were their exhibits. The late Mr. Harding proved the victor, but I venture to assert that the judges at those shows would say, if they had to make an affidavit on the matter, that every collection which Mr. Molyneux subsequently staged there was far in advance of Mr. Harding's. It seems natural for a man who rises above his fellows, no matter in what he may be engaged, to be the subject of a certain amount of envy. Rivalry is good and wholesome, but petty jealousy not worth encouraging.—W. D. No. 2.

#### MR. MEASE AND THE HULL CHRYSANTHEMUM TROPHY.

SOME years ago, when the Carter's cup for vegetables was offered for competition, I did not compete for it, as it looked too much like a decoy bird, but the firm was most honourable in the matter, and gave the beautiful trophy to its lawful and meritorious winner, and I hope the Hull Committee will do likewise. However that may be, I trust Mr. Mease will compete again this year, and if successful he will be the recognised champion.—J. H. GOODACRE, *Evaston, Derby*.

THE Hull Committee, through their Secretaries, inform the public that, having taken legal advice, there is no other course open but acting upon it. Surely an appeal by them to the parties personally interested in the competition will clear the way of all difficulties.

A peculiar hardship in Mr. Mease's case is that if he again enters the competition and is placed first, as very possibly he may be, his position will still be as anomalous a one as is the case at present. Being gardener to the executors of his late employers it is very improbable that they will carry on the gardens and retain Mr. Mease on the mere prospect of his winning the cup.

Supposing that he competes for and wins the cup at the forthcoming Show, I suggest that a fund be raised by public subscription to test the validity of the position of the Committee if they refuse Mr. Mease absolute possession of the cup. If other means fail to bring about a satisfactory solution of the difficulty I shall be glad to give my mite of 10s. 6d. towards the above object. On every hand we hear expressions of sympathy with Mr. Mease, and some have already promised practical help in this matter.—YORKSHIREMAN.

I HAVE noted the correspondence with reference to the Hull Challenge Cup for Chrysanthemums. It may possibly simplify the case if I at once announce that as I last year lodged a protest against the Judges' decision, and as those Judges have been this year re-appointed, the Otterspool Gardens will not be represented at the coming show.—D. LINDSAY (*for Sir T. Edwardes-Moss, Bart.*).

[As was stated in the report of the Hull Show last year, Mr. Lindsay only entered a protest against the awards in those classes in which he lost—not in the one in which he was awarded the first prize. His protest was founded on the assumption that the judging was not done by points. The Judges' "points" were placed before the Committee, and their accuracy was tested by scrutineers, who confirmed the verdict in favour of Mr. Mease and against Mr. Lindsay. We are authorised to state that the Judges expressed their readiness to be relieved from officiating this year, or to act with a third accredited Judge, who might be approved; one was appointed to whom Mr. Lindsay made no objection. He now retires.]

I HAVE read with astonishment in the Journal of 3rd inst. Mr. Udale's strictures on what he assumes to be the reasons actuating the Committee of the Hull and East Riding Chrysanthemum Society in this matter.

Mr. Udale has entirely failed to grasp the facts of the case, and attributes unworthy motives to the Committee, which could find no

place in the minds of honourable men. Mr. Udale writes, to quote his own words:—

"It is not possible to form a perfectly correct opinion of this matter, because we are not informed whether Mr. Mease entered the flowers in his own name, or whether he entered them in the name of his employer."

Notwithstanding Mr. Udale's admitted ignorance of the facts, he still apparently considers himself qualified to sit in judgment on the case. It is perfectly true, that by one rule of this, as of many other societies, the Committee "reserve to themselves the right to reject any exhibit." This rule, however, was never intended to be applied in such a case as this. If it could be so used, a Committee might always avail themselves of it whenever there was danger of a piece of challenge plate being finally won. In this case it so happens that the rule was never even thought of. Mr. Udale's own good sense ought to have saved him from making such uncalled for remarks.

The conditions affecting the challenge vase are as follows:—

"The winner to hold the vase until the next exhibition, when it shall be returned to the Society. Should the same exhibitor win the vase twice consecutively or three times altogether, it shall become his property. The vase to go to the employer, the money to the gardener."

These conditions, and these only, were considered by the Committee, and are those upon which the opinion of legal and horticultural authorities was asked.

The entry last year was made by Mr. Mease in the name of his employer, the late Mr. C. W. Neumann; therefore I think even Mr. Udale will admit that Mr. Mease, personally, has no vested interest in the vase whatever; and as regards any interest which Mr. Neumann's executors might have in it, our legal adviser is of opinion that the interest in it was personal to Mr. Neumann himself, and died with him.

This being so, the Committee, much to their regret, have no alternative but to decide that Mr. Neumann's executors cannot count last year's win; it would be manifestly unfair to the winner of the vase in 1885 if they came to any other decision, for it must not be forgotten that the Committee have their duty to the latter as well as to the former. They have endeavoured to act in an impartial manner, and if their sympathy with Mr. Mease led them to an illegal course of action, it would no doubt be called in question by the other winner.

Either Mr. Neumann's executors or Mr. Mease, are however, perfectly at liberty to compete as new exhibitors, and if any means can be found by which the former may be allowed to count last year's win, I am convinced our Committee will be only too pleased.

In conclusion I may mention that I saw Mr. Mease at the Bradford Chrysanthemum Show last Friday, and am happy to be able to state by his authority that he imputes no wrong motives whatever to our Committee.—R. FALCONER JAMESON, *Chairman Hull and East Riding Chrysanthemum Society.*

### VIOLAS.

I DO not think Mr. Steel has read my communication rightly, or he would not attribute to me any desire of absolute exclusion of any Violas; they are too highly esteemed by me for that. If Mr. Steel will read my note again at page 323, he will find that I merely exclude those varieties with rounded flowers formally, and refer them to the bedding Pansies. He also infers that Mr. Dean and myself are not agreed as to Archie Grant, but my statement runs thus—"If we rigidly pursue this course—*i.e.* calyx with unequal sepals, we shall exclude the best Violas, such as Countess of Hopetown, Lady Polwarth, and Archie Grant, and all those flowers having the same rounded tendency. These, then, would go to the bedding Pansies, while such as Mrs. Gray, elegans, Grievi, lutea grandiflora, and such like, would be retained as Violas;" and if he will compare Mr. Dean's remarks with the above quotation he will find that the latter and myself are quite agreed save in the case of Countess of Hopetown, which Mr. Dean, on account of its dense habit, early and continuous blooming, would place among the Violas. But if this be so, Mr. Steel and Mr. Dean are not agreed, for in Countess of Hopetown we have a decided self, and if the distinction is to be followed of close or dense habit, we must admit such as Mrs. Chas. Turner and Lady Polwarth, while Pilrig Park, Champion Bullion, with pencilled or rayed flowers, cannot be regarded as selfs in the same way as Countess of Hopetown. Still, I do not see the necessity for such a classification as this, and I think the whole might be more conveniently grouped under two heads—*viz.*, Violas and Bedding Pansies; beyond this, if occasion required, they may be grouped to colour, while the miscellaneous varieties, such as York and Lancaster, may be grouped as Fancies. Although Mr. Steel takes exception to the answer I give to his question—"What are the characteristics of a Viola?" he has not himself advanced anything more obvious, and requests me to examine a Pansy, but the Pansy has no existence botanically, and must be referred to the fountain head of *Viola tricolor* var., therefore the difference between a Viola and Pansy is nothing botanically, since they are, in the majority, the descendants of one species. Our florists past and present have lifted the Pansy to its present standard of perfection, and very naturally laid down hard-and-fast rules for their own guidance. One of these is form, which I take to mean symmetry, there fore nothing but a well rounded flower having all other qualities would be admissible, hence my reason for drawing the line at "unequal sepals;" for though this was allowed in the Pansies of fifty years ago, it is not admitted now, while Violas, such as Mrs. Gray, Elegans, Ardwell Gem, and many others, all have unequal sepals, which I have always regarded as typical of the Viola.—E. JENKINS.



A FULL meeting of the Executive Committee of the GARDENERS' ORPHAN FUND was held on Friday evening last at the "Caledonian Hotel," Adelphi, London, Mr. G. Deal presiding. Mr. Sherwood and Mr. John Lee were unanimously elected Vice-Presidents. After a careful consideration of the most convenient and absolutely safe method of investing a sum of money, it was resolved to place £500 in three per cent. consols, leaving a working balance at the bankers. Letters were read from gardeners of standing in Ireland, Scotland, and Wales, expressing their willingness to become local secretaries, and seven were appointed in Ireland and four in Wales; an addition was also made to the list in England, which now numbers nearly sixty. Messrs. Pope and Son, Birmingham; Messrs. Wood & Ingram, Huntingdon; and Messrs. Cannell & Sons, Swanley, kindly offered to distribute circulars containing a summary of the rules and subscription forms in their catalogues, &c., and a number were ordered to be printed for that purpose. At the next meeting, which will be held in December, it is not improbable that preliminary steps will be taken and methods formulated for dispensing such portions of the fund as may be justifiable, according to the rules, for the object for which it is being established. A feeling of satisfaction pervaded the meeting with the position attained, and with the co-operation of all who are willing to give it a great success is anticipated and much good expected to be done through the agency of the Institution.

— THE POSTPONEMENT OF SHOWS.—We have already announced the postponement of the Liverpool Show to the 29th inst. in consequence of the Assizes, and the Southend Show has also been postponed to the 15th inst. Probably we shall also hear of others, but it is a serious matter to alter the dates of exhibitions so late in the season as this, and Committees should be very careful before doing so to consult the intending exhibitors, or they may do a great injustice to some persons who have successfully contended against the retarding effects of the season. An experienced grower remarks that he considers "the greatest skill is shown when a competitor has his blooms up to time in an unfavourable year, and a week's delay will often render all his efforts useless." Still, when it is the general desire that a date should be altered, it is advisable to do so rather than sacrifice the show.

— A VISITOR writes:—"I was much interested in MR. GILBERT'S VEGETABLE NOVELTIES at South Kensington the other day, but what pleased me the most was the Universal Savoy. This seems likely to be a really useful vegetable, the hearts solid and compact, such as would take up little space in a garden and give good returns. I shall try this the first opportunity. The Chou de Universal (what an extraordinary name) failed to impress me as a good addition to our vegetable list. It resembled a very strong coarse strain of Brussels Sprouts, but perhaps it possesses some quality I could not detect."

— MESSRS. J. VEITCH & SONS exhibited specimens of their interesting hybrid BEGONIA ADONIS at a recent meeting of the Royal Horticultural Society, South Kensington, and the plant has also been attractive in their nursery for some time past. It will be remembered that Begonia John Heal resulted from a cross between *B. socotrana* and a tuberous variety, the former being the seed parent, and is remarkable for only producing staminate flowers. The pollen from this was applied to one of the best of the modern Tuberous Begonias, and from the seed thus obtained was raised Begonia Adonis. Much of the *B. socotrana* habit is observable in the seedling, the leaves being large and rounded, but the growths are those of the ordinary tuberous type. The flowers are large, with broad rounded petals, and the colour a pleasing rosy scarlet. It is not so free as *B. John Heal*, but is attractive and no doubt useful. If white or double varieties of *B. John Heal* could be obtained they would be welcome additions to the winter flowering section.

— THE WATFORD CHRYSANTHEMUM SOCIETY will hold their second annual Show in the Agricultural Hall, Watford, on Tuesday and Wednesday, November 15th and 16th. The fourteen classes are in six divisions, for all exhibitors, members employing two or more gardeners.

amateurs, and cottagers. The prizes range from £2 10s. to 1s., Chrysanthemums, miscellaneous plants, fruit and vegetables being included. The Hon. Sec. is Mr. C. R. Humbert, Watford.

— **THOUGH** possessing no claim to be regarded as a novelty, the **GOLDEN-EDGED PRIVET** is a handsome and neglected shrub, for it is seldom seen in gardens. Messrs. Laing & Sons have some excellent samples of it planted out and in pots, and the golden margin to the neat leaves, which are not quite so large as those of ovalifolium, is very rich and striking. The plant retains its leaves well, and at this time of year its colour is particularly bright, perhaps due in some degree to the dry hot summer just past.

— **IN** Mr. B. S. Williams' nursery at Upper Holloway we recently had the good fortune to see an extremely fine variety of **LÆLIA PRASIATA** which Mr. Fitch was sketching in his customary admirable manner. The plant is a very strong one, with branching stems and four flowering growths, each bearing a raceme of large highly coloured flowers, two having six each, one with seven, and one with four. The sepals and petals are purple tinted, but the chief beauty of the flower rests in contrast between the pure white tube of the lip and the broad rich crimson limb with unfolded side lobes tipped with crimson. The effect produced by twenty-two such fine flowers can be readily imagined, and we understand that the plant has been procured for one of the largest collections of Orchids in the south of London.

— **THERE** are many other noteworthy Orchids and general flowering plants in Mr. Williams' large collections, but just now we can only accord a special paragraph to **PLUMBAGO CAPENSIS ALBA**, which is destined to become a companion for the familiar blue form in some hundreds of gardens. Some little doubt has been expressed by those who have not seen this variety in flower as to whether it would prove pure white, as so many so-called white varieties of blue flowers come with a faint tinge of colour. The plants of the Plumbago that have been flowering for some time past at Holloway effectually dispel all such uncertainty, as the flowers are a pure opaque white and without the faintest tinge of colour. The plant is of free flowering and vigorous habit, and is well adapted for culture in pots or training to the roofs or pillars of conservatories.

— **THE** supplies both of flowers and fruit in **COVENT GARDEN MARKET** are abundant, and amongst the former Bouvardias and Chrysanthemums are conspicuous. The red and white varieties of Bouvardias are in much demand, as they can be used in the most choice arrangements of flowers, and they possess a fine wax-like substance that fits them for association with any of the usual bouquet or wreath flowers. White Chrysanthemums, either Pompons, Japanese, or incurved, are largely used; a few of the more delicate shades of yellow or bronze also being favourites, while the scarlet *Roi des Précoces* has already made its appearance in some of the florists' shops. Plants of *Alexandre Dufour* in small pots prove how well adapted this variety is cultivated in this style, as in a dwarf state the flowers are produced very freely, and the colour is a pleasing one. Apples and Pears are the most abundant of the fruits, good and cheap samples of both being numerous under a variety of erroneous names. The Apple and Pear Congresses may have assisted in correcting the nomenclature of fruits grown in private gardens, but they do not seem to have done much for those sent to market.

— **"S."** sends the following note on **PANSY CUTTINGS**—"This may appear a late period for inserting cuttings of Pansies and Violas, but I have found that late in October and early in November, so long as the frost is not severe, is a suitable time for the work. The soil is well dug, a little old manure is incorporated with it, but if the soil is naturally rich this is not necessary, and the chief point is to provide thorough drainage. If the soil is finely pulverised the cuttings root readily when inserted firmly in lines, and beyond seeing that they are not forced out of the ground by frost little attention is needed until they are transplanted in spring."

— **REFERRING** to the award of **CERTIFICATES TO OLD PLANTS**, "An Old Florist" writes—"Is there any rule to regulate these awards at the Kensington Floral Committee meetings? It seems not, for sometimes an old plant is certificated, and at others an equally meritorious old plant is disregarded. Does it depend upon the partiality of influential members of the Committee for particular classes of plants? I have noted some very peculiar instances of both the above cases, and being unable to discover any rule for them I thought, perhaps, some of

your readers could enlighten me. There are numerous excellent plants that have never been certificated, and some that are as scarce as introductions of the current year, but rarity cannot be a sufficient recommendation for such awards."

— **ALEXANDRA PALACE ROSE SHOW.**—Mr. Jno. Bateman, 72, Twicken Road, N.W., writes—"Can you spare me a little of your valuable space in which to ask whether the exhibitors at the above Show, held last July, have received any of the prizes then awarded? Not having received mine, or any word about them, I wrote twice to Mr. J. S. Cooke, the Secretary, but failed even to get a reply."

— **THE** autumn Exhibition of the **TWICKENHAM HORTICULTURAL SOCIETY** will be held on November 15th and 16th, in the Town Hall of that town. The schedule enumerates thirty-five classes, in the majority of which three prizes are offered, Chrysanthemums, plants, and cut blooms constituting the chief features. Miscellaneous plants, vegetables, and fruits are also well provided for, and these usually form an important attraction at the show. Many of the prizes are liberally offered by friends of the Society in the district. The Hon. Sec. is J. J. G. Pugh, Esq., 2, Heath Road, Twickenham.

— **AT** South Kensington recently, Mr. J. Crook, Farnborough Grange Gardens, Hants, exhibited several well-grown plants of **TRICHINIUM MANGLESI**, which is seldom seen in first-rate condition, although it has been grown very successfully at Kew. With them were some pretty *Celosias*, *Salvias*, and the useful *Primula obconica*.

— **WE** are informed that the Committee of the **HULL CHRYSANTHEMUM SOCIETY** have erected a building 100 feet long adjoining the Artillery Barracks, for large as this building is it is inadequate for the accommodation of the products staged and the crowd of persons who attend the Show. The Exhibition is expected to be a very fine one, and much as the legal decision is regretted that affects Mr. Mease, and which the Committee are bound to obey, it at least affords a wider opportunity for other competitors winning a position in the coming contest.

— **A** **NORTHERN AMATEUR** says: "The reduction in the price of **GLADIOLI** of late has been so great that a dozen first-rate sorts may now be had for the cost of one five or six years ago. This makes loss of the earnings a comparatively trifling matter, and the grand flower should now be grown everywhere. In some catalogues, such, for instance, as that of Mr. Campbell of Gourrock, the order in time of flowering of the French varieties is carefully indicated in four classes. In our northern climate the latest sorts can be got to bloom only in favoured spots, and even there in exceptional seasons. Purchasers not acquainted with the *Gladiolus* should confine themselves mainly to the two earlier sections; the third is at best uncertain. The classification in the catalogue affords broadly a reliable guide, but remarkable deviations in the matter of time occur in all the classes and in different plants of the same variety."

— **WE** are requested to state that the address of Mr. **WILLIAM DEAN**, florist (late of Walsall), is now Mill Lane Nursery, Solihull, Birmingham.

— **A** **CORRESPONDENT** sends us a report of the autumn Show at the **GREAT WESTERN NURSERIES, GLASGOW**; but our pages were filled to overflowing on its receipt. The different structures are described as being attractively furnished, and were admired by nearly six thousand visitors.

— **MR. H. ALDERMAN**, gardener to G. Hatfield, Esq., Morden Hall, Mitcham, has harvested a grand crop of **APPLES**, mostly from old orchard trees. A very useful variety, and one which ought to be more extensively grown, is "Lewis's Incomparable." The fruit is large and very even, and more than 10 bushels have been gathered this year from one or two trees.

— **MR. G. W. CUMMINS** writes—"Mr. Thomas Creed, gardener at Hill Top, Bramley, Leeds, is a successful grower of **POINSETTIAS**. The method he has adopted for some years is to cut down the plants (after they have rested a time) to within 3 or 4 inches of the pot, and when they commence growing, about three shoots are allowed to remain. These are encouraged to grow strongly, and with his treatment they each attain the height of 9 or 10 feet, with bracts 20 inches in diameter. Some of his plants are several years old, but he is of opinion that they are at their best when three years of age."

— **MR. CHARLES BENHAM**, Middleton Hall Gardens, Leeds, has some **STRAWBERRIES IN POTS** bearing a fair crop of fruit. The plants were



forced early in the spring, and after the produce was gathered they were placed outside and watered as required. At the end of August second blooms were observed, and when we saw them a few weeks ago they were arranged in their old quarters in a vinery, and judging from their appearance it will be an experiment worth repeating.

— THE eleventh number of the KEW BULLETIN is devoted to descriptions of "Colonial Fruit," comprising Apples, Pears, &c., with a view to encouraging their production in Canada, Cape Colony, Natal, Australia, and New Zealand. The imports of fruits into Canada are stated to be as follows:—The imports of such fruits into Canada (as might in large proportion be grown here) for the year ended June 30th, 1886, were as follows:—Apples from the United States, 31,575 barrels, value 63,775 dollars; small fruits—viz., Blaekberries, Gooseberries, Raspberries, and Strawberries, from the United States, 231,378 lbs., value 23,557 dollars; Cherries and Currants, from the United States, 51,085 quarts, value 4914 dollars; Cranberries, Plums, and Quinces, from the United States, 17,170 bushels, value 34,650 dollars; from Newfoundland, 15 bushels, value 13 dollars; Grapes from the United States, 389,863 lbs., value 27,340 dollars; Peaches from the United States 592,880 lbs., value 42,571 dollars.

## MEMORIES OF A TOUR.

(Continued from page 380.)

### TWO CASTLES AND THEIR SURROUNDINGS.

LEAVING the Marquis of Bute's kitchen gardens, we cross the highway into the Castle grounds, then take a drive of four or five miles to Castle Coch to see the vineyard. First let us look at Cardiff Castle, or as it was described in past times, when princes dwelt therein, Caer Taff or Caer Dâf, the Fortress on the Taff, the river that rolls hard by. It is a truly noble building in splendid condition, a great portion appearing to have been rebuilt—indeed its restoration by the present Marquis, if I remember rightly, involved an expenditure of £160,000; one tower, St. George's, I think it is called, costing £50,000. Externally the architecture of this tower is very beautiful, while the mediæval decorations of the interior are superb. The noble Marquis is a great patron of art, and has it represented in its highest forms. We had the privilege of an ascent up some 170 stone steps, and though it was a tedious twisting journey, the fatigue was forgotten when the uppermost room was reached. Rich beyond description is the furnishing and treatment of the walls and pillars, yet without a suspicion of gaudiness; the sculptures, paintings, and stained glass blending in pleasing harmony. What a change from the turbulent times of the past, when the double moat was forded and the Castle lost and won by the force of arms. The moat that surrounds the walls encircles many acres, a second moat protecting the keep that stands alone within the enclosure some distance from the main building. The walls extending from this like huge protecting wings, reaching nearly to the keep, are massive and high. One of them terminating in Robert's tower, with its dismal entrance the same as it was more than 700 years ago, when Robert of Normandy was imprisoned in the dungeon for twenty-six years, and for trying to escape had his eyes put out. We read much about the chivalry of the days when might was regarded as right and brutal force as king, but it is to be feared its lustre was deeply tarnished with cruelty. The top of one of the walls forms a promenade that can have but few parallels. It is quite level, perhaps 150 yards long and 10 feet wide, clothed with grass, and flanked on each side with battlements 2 or 3 feet high. Trees grow out of the wall and in places form a canopy overhead, and to look down into the depths below is enough to turn nervous tourists dizzy. The walls from the outer side are clothed with various creepers and ivy that, judging by its stems, must have held its position for centuries; but the wall on the town side is covered with Vines to a height of about 30 feet, the finest Vine wall no doubt in the kingdom. Several varieties are planted, the rods trained vertically. The Grapes were generally ripening well, and the crops, notably on the young wood, very good indeed, lighter where elose spurring had long been practised. The juice of these Grapes is perhaps now fermenting for light wine—not the best, for Mr. Pettigrew is an adept at wine-making as we shall see by-and-by.

Previous to his entering on his extensive charge there were practically no dressed grounds near the Castle. Now, apart from the small lawn within the moat, and the few flower beds, one "swallowing" 3000 plants, there are about thirty acres of lawn as level as a bowling green and as smooth as velvet. Leaving the burnt pastures in fields, and the seared grass plots in gardens, in the south of England, it was most refreshing, even exhilarating, to look on this bright green lawn, on which the long shadows of the trees were clearly defined by the bright declining sun. Not a sign of drought was apparent, yet it had been a "terrible" summer. Wherever we went, save in one instance, we were impressed with the views there held, that nowhere else could the drought have been so serious. The heat may have been great, and the scarcity of rain inconvenient, but the recovery therefrom must have been sudden, for the grass was as green in Cardiff and in other gardens in Wales as if it were growing in April, whereas in some parts of England the prevailing tint was brown a fortnight after we left the vale of Glamorgan. No, my friends in the principality, I am not con-

vinced you have undergone such a roasting ordeal as your brethren have had to endure in some of the higher, and, as I think, drier districts of Britain, therefore be thankful. It is right to observe that Mr. Pettigrew did not blame the weather for any scarcity of garden produce, for he could say, and with truth, that he had "plenty of everything," and of many crops plenty to spare.

The pleasure grounds are being extended at the rate of about four acres a year, lawns being made, drives formed, and shrubberies planted; and if the work continues a few years longer it looks like reaching Llandaff. And it is all done well, though a large piece of this smooth lawn has to be made over again. It is in this wise:—The drought revealed the existence of something below besides soil; and as Lord Bute likes going to the bottom of things, and has strong archaeological proclivities, digging commenced and was continued till the foundations and lower portions of the walls of an ancient monastery were laid bare. It has been no light task, but was conducted cheerfully by Mr. Pettigrew, and in due time, when plans are settled, all will be put right and the rough made smooth once more. Yet, though the noble margins adds to the beauty and interest of his estate, which he has good right and great reason to enjoy, he does not live for himself alone, making no provision for the industrial population of the thrifty town for which he and his predecessors have done so much and received so much in return. The advantages are mutual, and here, if anywhere, the aristocracy and democracy appear to march hand in hand; at any rate, the coronet is prominent on the railway engines at the docks, indicating their ownership, while the men who drive these engines look as happy as if they were lords and masters of the whole concern. Well, for these, and all who choose to enter them, pleasure gardens eleven acres in extent have been provided alongside of the Castle grounds. These gardens have been established some years, and the trees overshadow the paths, which are thus cool promenades in the summer. In half the public gardens in England trees have been planted far in the background, where they spoil the shrubs beneath them, while the walks are exposed to the burning sun, visitors either shunning them or panting for the shade that they cannot enjoy. They make no such mistakes on the Continent, the first consideration of the authorities there being to provide shade, which is so restful and delicious, where it can be the most conveniently enjoyed during the period of outdoor life, that is so wholesome near towns. The glaring sun pouring down on the London Thames Embankment gardens simply drives the people out of them in hot weather, or they herd together under the few isolated specimens in crowded discomfort, while at the same time there is shade enough in the enclosures that cannot be enjoyed, because either the trees or the walks are in the wrong places. The Marquis of Bute has given ninety acres of land at Cardiff for a public park, and it is hoped those who are responsible for laying it out will not plant all the trees as far from the roads and walks as possible, but will take care to provide shade for the multitude, as is done by the Elm avenue in Battersea Park and the Chestnut walk in Regent's Park, that are delightful resorts for Londoners to lounge in during the tropical period of the year.

In continuation of the pleasure garden referred to, a recreation ground of 4 acres has not long since been completed by Mr. Pettigrew, and here the youth of the town can indulge in sports and trials of skill that are necessary for the physical development of those whose days are spent in shops or sedentary employment. Nor have those who need not such stirring exercise been forgotten, and for such a bowling green has been made at a cost of £1400. It is one of the best we have seen, with well-appointed rooms attached, and our friend is to be congratulated on the excellence of his work. There are also twelve squares in the town, most of which have been planted by Mr. Pettigrew, and for the keeping of all he is responsible. It appears evident that every reasonable want is provided, and it is clear that whatever is undertaken is carried out well. This is not wasting money, but expending it wisely; it is wasted when work is only half done, leaving an inheritance of patching and botching that gives satisfaction to no one. Thoroughness appears the governing principle in the conduct of improvements effected on Lord Bute's estate. A project now in hand affords an example of this. It has been said the Castle grounds and the kitchen gardens are situated on opposite sides of a main thoroughfare. From the castle walls, which are high above the road, across the moat and highway, is a great distance to bridge; yet it will have to be done, and to do it in a style worthy of the place will necessitate an outlay of £30,000—a nice little bill for making a walk to a garden.

A reference to Cardiff would be incomplete without including the docks. They are the chief agents of its prosperity, and the outcome of the foresight and energy of the Bute family in past generations, with a continuation of it that shows no signs of abatement; £3,000,000 have been expended on them and the approaches, the new dock of 36 acres, opened this year, having cost £500,000, and its equal, perhaps, cannot be found. The merchandise is coal, all coal, the output being between 7,000,000 and 8,000,000 tons a year, or, say, 150,000 tons a week. Trains run to the ships' side, a 10 ton truck is run on a platform, which rises high enough, by hydraulic power, for tipping, and the contents are turned into the hold with greater ease than a gardener tips a scuffleful of soil on a potting bench, and about as quickly. When the tipping is in full progress the noise is like a protracted, yet intermittent, roll of thunder. Yet with all the attendant dust the main portion of the town is not black, and if we take the police as representing the inhabitants, they are the cleanest, finest, smartest men we have seen in the "foree" of any corporation.

We have seen what wealth can do when well applied, what labour it

employs in creating more, what an impetus it gives to trade and to art, what an incentive to the development of capacity; and if we trace it to its source we must follow the black caverns under mountain and plain, and though we recognise the presiding lord of the castle as good and great and noble, yet, after all, no other conclusion can be arrived at than that coal is king at Cardiff.

#### CASTLE COCH.

The drive from Cardiff to this ancient Castle is through a flat country. It is not picturesque, but the land is evidently fertile, and some, but not all, well cultivated. If I were asked what was the most noticeable feature along the route, which includes a village or two not quite arcadian in aspect, I should be inclined to say the number of dingy, repellent, not to say ugly, public houses. One or two looked snug, clean, respectable hostelrys, but the majority were the reverse of tempting to wayfarers. Passing through one village, however, with an unrememberable name, we admire a bright cheerful little mansion on the right, standing in well-kept and attractive grounds, which both owner and gardener must take delight in. This residence is in a measure historical, for the late Lord Beaconsfield spent many happy hours in it before he took therefrom a wife; and this reminds me of a memorable afternoon spent with Mr. A. F. Barron in the House of Commons, when the famous statesman's great political antagonist made an earnest and eloquent appeal for a national monument for him, which speech the then Sir Stafford Northcote, with his proverbial grace, described as a memorial in itself never to be forgotten, and imperishable. Thus party strife was hushed, and perhaps for the only time in my life I was really satisfied with the utterances of public men. If there should happen to be any readers who dissent from these remarks, I must ask them to blame Mr. Pettigrew for driving me past that house in Wales and awakening these slumbering memories. However, my reverie is ended, and we push on to Castle Coch. We see it ahead of us, rising above the trees on the slope of a commanding hill, and shortly reach its portal.

It is an ancient fortress, but not very extensive, overlooking a pass between the hills on the east and down which a river flows, while the outlook from its towers southwards embraces a great extent of country to the Bristol Channel. It was for many years an uninhabited ruin, but has been restored by the present Marquis of Bute to its pristine strength, and the interior beautified in a manner that its old warlike chiefs never dreamt of. It is entered by a drawbridge and protected by a portcullis as in the olden time, and forms a quiet and secluded residence for the family when they wish to move from the greater building near the busy town for a few days' rest. It is surrounded by trees, indeed appears to be situated in a great wood, but not very far from its margin on the sides indicated, but high above the level of the surrounding district. It is a romantic looking pile, of a kind that baffles the enterprise of American millionaires to produce, one of whom once told me on an ocean steamer they could get anything for money but the old castles in the old country, and in respect to these they would own to being "whipped." Something has happened, deferring a reference to the chief object of our visit—the vineyard—to a future issue.

#### EARLY CHRYSANTHEMUMS—SAVING SEED.

It must be remembered that in these notes I do not write about the prizewinning class of plants, unless they are like Madlle. Lacroix, good for all purposes; but about those that are early, semi-early, good for the open garden, and as pot plants for decoration, for market and large quantities of cut flowers. These monster one, two, or three flowers on a plant, are not indicative of the ability or strength of a sort as a flower producer in other modes of culture. The certificates granted, too, are very misleading, some even being given to old sorts—see for instance at South Kensington, the Floral Committee's first-class certificate on the 11th of October this year to L'Africaine.

This season has not brought many striking novelties in early flowering Chrysanthemums, and the long continued dry weather during the summer has rendered it hardly fair to fully judge the merits of those new sorts we have had under cultivation. We have learned this by observing the behaviour of several old varieties—for instance, some have come later and partly failed. I will deal first with the shows. That at the Crystal Palace on the 2nd and 3rd of September being a week earlier than usual, added to the effect of the season, which seemed to drive the flowers later, was not in favour of the display, in this instance only consisting of two competitors—viz., Messrs. Davis & Jones of Camberwell and myself, though Mr. Miles of the Dyke Road, Brighton, sent a very fine group of Mrs. Burrell for which he received a certificate.

At the Aquarium Show on the 13th and 14th of September there was no particular new sort shown. The groups had the advantage of not being so tall as usual, and a new exhibitor, Mr. J. H. Witty of Highgate Cemetery, showed well. This is interesting, as it reveals the progress being made and the fitness of these plants for such places. The most striking advance in this exhibition was in the collections of cut flowers, the first prize going to Mr. Kendall, Rochampton, but he had old Chromatella and not F. Marronet, which is better. Mr. T. Ware of Hale Farm Nurseries, Tottenham, put in, I believe, a first appearance in this class with a thoroughly representative exhibit, which had all been grown in the open ground, showing their capacity as open garden flowers. Mr. J. Blackburn, gardener to Mr. J. Scott, jun., Elmstead Grange, Chislehurst, took first prizes for eighteen and twelve blooms of Madame Desgrange, which were very fine. Mr. H. Elliott, gardener to

Mrs. L. Harrison, Leyden House, Mortlake, took first prize for twelve blooms of the yellow Desgrange, also very good; in fact, the whole show exhibited marked progress, but I think there should be some regulation in the class for cut flowers to discourage more than one bunch of a sort and to encourage the exhibition of new sorts. I noticed several old varieties shown when there are better ones in cultivation, such as old Illustration instead of Salter's Early Blush. I did not exhibit, as I do not quite like the mode of judgment. Personally, I have no objection in any way to Mr. Holmes; he is polite, obliging, and energetic, but as chief officer of the National Chrysanthemum Society I do not think it is good for him to act as judge or referee at the Society's shows. If two judges are not sufficient, and in some cases they may not be, by all means have a third, but that third should not be anyone who must know who is the owner of each exhibit to be judged. Last year I did not know that Mr. Holmes was a kind of third judge, but when I received the report and schedule of this year it was plain enough, and I think it is not for the benefit of the Society that it is so.

The difficulty of last season with regard to the Chrysanthemum Mrs. Burrell has disappeared I am satisfied, as I have grown both it and the yellow Madame Desgrange, and I see it is slightly paler. Besides, I have had the opportunity of seeing a large number growing together mixed, and it was then quite easy to pick out the pale ones; still the difference is so small that unless they are grown side by side many will say they are the same.

Mr. J. R. Pitcher has this season come out well. Messrs. Davis and Jones, both at the Crystal Palace and the Aquarium, Westminster, exhibited some noble flowers from 5 to 6 inches across, of course disbudded blooms, and I showed at the Palace some good plants of natural growth. Its value consists in its differing so materially from Madame Desgrange, which has pointed florets, while Mrs. Pitcher has rounded florets and of a different shade of colour.

Leoni Lassali; with extended stock I have been able to test the varied merits of this. It is a peculiar but capital plant, with the habit of disbudding itself in a measure, for some buds fail and others come out into large flowers. I have had it in bloom from May, and it was flowering on October 30th, many of the flowers being 3 inches across. It comes into competition with Blanche Columbe, which I think it will surpass. Wm. Holmes has proved a first-rate scarlet crimson Japanese; it is a superb plant either to grow for show bloom or for masses of flowers. It likes a large pot, but can make a good specimen in 32-size. It is in the way to M. H. Jacotot, but does not seem to pale under glass so much as that does. It is probably rather earlier too, is of more robust habit, and is a more profuse bloomer; besides, when all the buds are left on it has rather longer stalks to keep the flowers apart. I doubt not that it will prove a great market sort for cut flowers. It stands a fair amount of frost even when the flowers are partly out.

I have been growing this season Vierge Japonaise. It is very much like Madlle. Lacroix and is said to be a seedling from it, but the flowers seem not quite so large, though they are very beautiful, and the plant has power enough to develop every bud to a flower worth looking at. It will be most useful amongst white flowers in October.

Alice Butcher is coming into favour, and is certainly the best early red Pompon, with Pierre Verfil and Toreador making the three best early reds. Red Luxembourg is likely to be good for rough culture, and my red orange to yellow Piercy's Seedling seems likely to be useful for market.

Many of the new sorts of this season sent us as early have proved by no means so, and some of the French ones are rubbish, notably two sent us by Délaux, "Nain Perpétuel" and "Nanum Tolosanum." In the first place, they are so much alike that I fail to see the least difference, and they are neither of them so good as old Curiosity, which we gave up years ago. Out of twenty-eight new this season on Délaux's list marked as early most have not bloomed till October, and at present I have only found seven that are either semi-early or remarkable. All this wastes time, labour, and money, and will certainly tend to damage the reputation of those growers in France who serve us thus.

One of the best finds of the season is Golden Fleece, of American origin. It is very early, blooming at the end of August, of a bright lemon yellow slightly resembling a Dandelion in form. The flowers are about 2 inches across, and the plant 2 feet high. It comes into competition with Flora, but the individual flower stalks are longer, making it in some cases more desirable as a cut flower.

Lord Mayor, a new French variety; dwarf bushy plant, 3 feet high, flowers about 3 inches across; colour slightly resembling White Cedo Nulli; base of petals white tipped pink; reflexed, very full and charming flower; most profuse bloomer in October. Will make, I think, as the French say, a good small pot plant for market.

Lambeth Amateur is a most remarkable dwarf, robust variety, with leaves like none other, more like pieces of Cabbage leaf than anything else. I have a plant 3 feet high, which seems its natural stature, which is 3 inches round the stem at the base. The flowers are from 3 to 4 inches across, white with a pale yellow centre, florets very broad and much reflexed. Blooms in October.

M. Chrétien, a good stout Japanese sort, grows about 3 feet high, blooms 3 to 4 inches across, florets magenta in colour, standing out straight, blooms in September. Marie Ouvray is an October bloomer, deep magenta Japanese, about 4 feet high, flowers 4 inches across, the florets very much reflexed. Mrs. Matheson (Matheson) has shown no sign of bloom at the end of October. Panaché Toulousain and Fanchette are not worth growing.



I remember years ago when I used to have all my Chrysanthemums destroyed by the frost just as they were coming into bloom in the open ground it led me to grow early Chrysanthemums, thinking when I had the first Nanum into bloom in May why I could not grow seed. Well,

Davis, lately of Plumstead, Kent (no relation of Mr. N. Davis of Camberwell, London), had grown fertile seed there, from which he raised good seedlings. M. V. Lemoine of Nancy, France, says he could not grow seed there. I sent my early sorts to Mr. Laxton of Bedford, and



FIG. 51.—CRINUM HILDEBRANDTI (SEE PAGE 398).

he trial was made, the seed was looked for, but none obtained. Information of growers was sought. I was told to pull the middles of the flowers out; still with no results. It was said that plants from seed had been accidentally obtained in the nursery of Mr. Drain, Southgate Road, Kingsland, from which some good sorts were grown; and that Mr.

he failed to get good seed; and also to Mr. H. Elliott of the Springfield Nursery, St. Heliers, Jersey, who also failed. From all this and other experience I came to the conclusion that we must have season enough, flies enough, and pollen enough, which latter condition in these beautiful double flowers is wanting—there is no pollen and no fertile seed. The



next thing to consider was that there were no early or semi-double sorts to be obtained, which shut off progress in that direction; but in a season or two, through the craze for single flowers, one was saved by W. H. Cullingford, Esq., of Crouch House, Seaford, Sussex, from seed he had from Mr. Hartland of Cork, Ireland, for which reason it was named Hartland's Marguerite. From that last season I grew good ripe fertile seed. When I first raised seedlings years ago it was, of course, from foreign seed, and my first season they grew with vigour; leaves, stems, and roots all through the summer, but neither buds or flowers appeared. I was then told, "Oh, they do not bloom the first summer," so grew them on again the next. When well into the autumn they did flower, but proved useless. I afterwards grew others, but always thought from the results

then in bloom, or anything near, and some are not now (October 30th). But the surprising part was the great variation, for no one would have thought, without the same experience, that they could have all come from the same plant, foliage, habit, and strength being so different; some very strong, others very weak; some tall, some short; but none was so tall as the parent. Though two were earlier, most are later. This great divergence is very strange and instructive. It is so different from our wild *Chrysanthemum* (*C. leucanthemum*), which does not vary in the least when grown from seed. I may mention here that at Santa Barbara, California, Mr. Holland says the seed of *Chrysanthemums* there falls out and germinates when the rain comes. He does not say what sorts, but I suspect only semi-double or single sorts. We want a

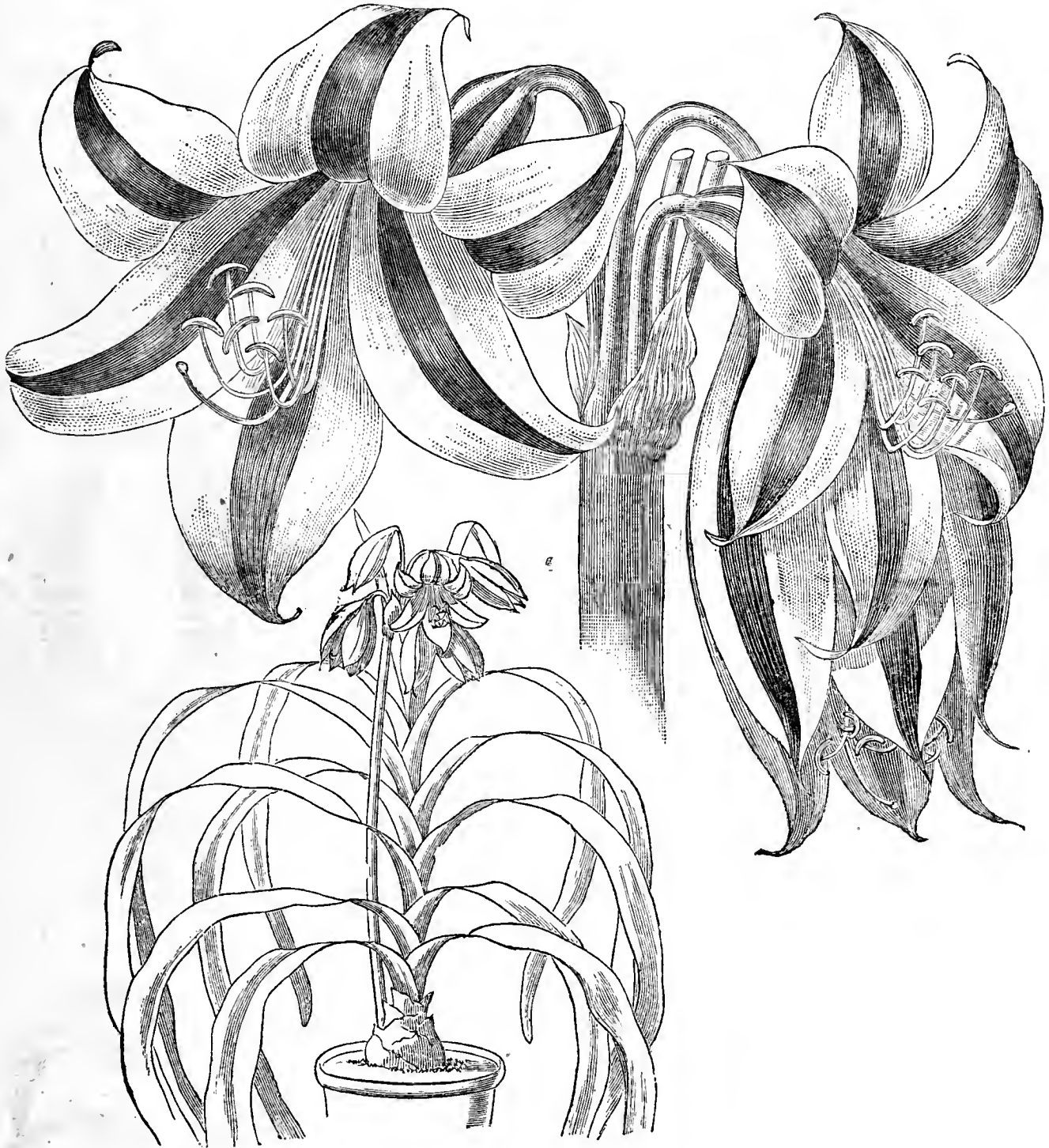

FIG. 52.—CRINUM KIRKI (SEE PAGE 398).

that the seed was saved in the most slovenly way from very indifferent and mixed plants.

A season or two ago, Mr. Thorpe of Queen's, New York, U.S.A., sent me a small parcel of seed, to me of unknown parentage, from which I raised about 120 plants, sowing in slight heat on the 1st of March, one of which turned out good dwarf and very early, called Piery's Seedling. Two others fairly good did not bloom that season in time to judge them, but did in 1886. They are Ella Zuila and Crimson Anemone. These seedlings, like all others, were very various. This seed of my own growing was not so good-looking as the trade seed is, and more resembled that sent from New York, for with a glass you may pick out almost every seed that will grow. I sowed my own seed on the 1st of March in heat, and by the end of August two plants had bloomed, and I believe one had ripened seed. —All the others, thirty-six in number, were not

few enthusiastic amateurs like the Rev. F. Freeman of Wickersly Rectory, Rotherham, to carry on this work.

I may suggest that the new *Leoni Lassali* is a promising sort for a seed parent, having pollen in some flowers. It will bloom in May from old plants, or struck cuttings the summer before. *Roi des Précoees*, too, though later, like *Leoni Lassali*, has a little pollen. Our great want is a good early crimson Japanese, or in fact any other sort if of good colour and one suitable for lamplight. *Roi des Précoees* is acceptable for this reason, I believe, for as a flower it has neither size nor form to recommend it. It is not unlikely that *Mrs. Le Mout*, although little more than a single, will prove saleable as a cut flower, as it is a good colour, a robust plant, and profuse bloomer, though not quite so early as *Roi des Précoees*, flowering from the middle to the end of October.—W. PIERY, 89, West Road, Forest Hill, S.E.

## GARDENERS' ORPHAN FUND.

A WELL-ATTENDED meeting of the Committee was held at the Caledonian Hotel, Adelphi, on Friday last, Mr. George Deal in the chair.

Amongst others, donations of 20 guineas from Mr. Sherwood (Hurst and Sons), and 5 guineas from Mr. John Lee were reported, these gentlemen being unanimously elected to the office of Vice-Presidents.

Of the subscriptions and donations already received, it was agreed to invest the sum of £500 in Consols.

The following gentlemen having intimated their willingness to act as Local Secretaries were duly appointed:—

## ENGLAND.

(In addition to previous List.)

- Mr. G. R. Allis, The Gardens, Old Warden Park, Biggleswade.  
 Mr. W. Blair, *Free Press* Office, Tonbridge.  
 Mr. W. Bryant, Nurseryman, &c., Rugby.  
 Mr. J. Burn, Abbey Park, Leicester.  
 Mr. W. A. Green, Corporation Street, Manchester.  
 Mr. J. Gore, Nurseryman, &c., Sefton Park, Liverpool.  
 Mr. J. Hughes, Northwood Villas, Metchley Lane, Harborne, Birmingham.  
 Mr. L. Kershaw, 20, Gladstone Road, West Hill Park, Halifax.  
 Mr. G. Nqrman, The Gardens, Hatfield House, Herts.  
 Mr. W. Ratchelous, St. Neots, Hunts.  
 Mr. T. Wilkins, The Gardens, Inwood House, Henstridge, Blandford.  
 Mr. D. Williams, The Gardens, Canford Manor, Wimborne.

## SCOTLAND.

- Mr. R. P. Brotherston, The Gardens, Tynningham, Prestonkirk.  
 Mr. P. Drummond, The Nurseries, Stirling.  
 Mr. G. Day, The Gardens, Galloway House, Garlieston.  
 Mr. R. Laird, The Nurseries, Edinburgh.  
 Mr. H. Ross, The Gardens, Dalcherizic by Crieff, Perth.

## IRELAND.

- Mr. T. Bradshaw, The Gardens, Hillsborough Castle, Hillsborough, County Down.  
 Mr. H. Carter, The Gardens, Downhill Castle, Coleraine, Co. Kerry.  
 Mr. E. Dumper, The Gardens, Summerville, Limerick.  
 Mr. A. Porter, The Gardens, Woodlawn, Co. Galway.  
 Mr. T. Sheasby, The Gardens, Castle Dillon, Armagh.  
 Mr. E. Tucker, The Gardens, Curraghmore, Portlaw, Waterford.  
 Mr. W. Wilson, The Gardens, Dromoland, Newmarket-on-Fergus, Co. Clare.

## WALES.

- Mr. A. Calder, The Gardens, Vaynol Park, Bangor.  
 Mr. W. B. Fisher, The Gardens, Stackpole Court, Pembroke.  
 Mr. J. S. Trevor, The Gardens, Bryngwyn Hall, Bwlch-y-Ciban, Montgomery.  
 Mr. G. Vearcy, The Gardens, Gogirddan Hall, Aberystwith.  
 Mr. F. Woodward, Nurseryman, &c., Llandaff.

A goodly supply of subscription forms and circulars is now prepared, which nurserymen and others may wish to distribute in their catalogues. These may be obtained on application to Mr. A. F. Barron, Honorary Secretary, Royal Horticultural Society's Gardens, Chiswick.

## ROYAL HORTICULTURAL SOCIETY.

NOVEMBER 8TH.

OWING probably to the abundance of Chrysanthemum attractions elsewhere the exhibits at Kensington were very few on Tuesday, and the Committees' duties were quickly performed.

**FRUIT COMMITTEE.**—Present T. F. Rivers, Esq., in the chair, and Messrs. John Lee, W. Paul, J. Smith, J. Willard, G. Bunyard, J. Woodbridge, G. T. Miles, G. Norman, T. B. Haywood, H. J. Veitch, W. Warren, R. D. Blackmor, and P. Crowley. There were very few exhibits before this Committee. Messrs. Rivers & Son, Sawbridgeworth, were awarded a vote of thanks for a new black Grape named *Prenelaan*, in the way of Mrs. Pince, but with a sweet not a musky flavour. A vote of thanks was also accorded to Messrs. W. Paul & Son for two dishes of Pears named *Fondante Thiriot* and *John Mannington*, the former being of good flavour. J. Gabb, Esq., Bewdley, showed fruits of a seedling Pear, like a small Bergamot, but it was over-ripe. Mr. F. Tozer, Leamington Spa, sent some seedling Potatoes raised from seed this year, the fourteen kidney-shaped tubers being all from one seedling.

**FLORAL COMMITTEE.**—Present G. F. Wilson, Esq., in the chair; Rev. W. W. Wilks, J. Fraser, H. Bennett, H. Herbst, G. Duffield, W. Goldring, W. H. Lowe, B. Wynne, H. Ballantine, C. Pilcher, E. Hill, J. Doiny, H. M. Pollett, J. O'Brien, A. Lundy, T. Baines, J. Walker, and W. Holmes. Messrs. J. Veitch & Sons, Chelsea, sent several new Chrysanthemums and a box of *Bouvardia* blooms, together with plants of the brilliant red *President Cleveland*. Mr. A. Hart, 130, High Street, Guildford, was awarded a vote of thanks for a richly coloured broad leaved *Coleus* named *Hart's Conqueror*. Mr. Lawrence, gardener to B. Knox, Esq., Caversham, was awarded a vote of thanks for a *Cypripedium Lawrenceanum* with twin flowers. Mr. W. Cummins, The Grange Gardens, Carshalton, exhibited a plant of *Celogyne Gardneriana*, with a spike of white flowers and lemon coloured lips (vote of thanks). From the Society's Gardens, Chiswick, came a group of winter flowering *Begonias*, comprising *insignis*, *Knowsleyana*, *Carrieri*, and *Saundersi*, freely flowered. Mr. W. Holmes, Hackney Road, had a vote of thanks for a group of

dwarf Chrysanthemums, mostly new varieties Japanese, of the present year, and the group merited a higher recognition. A bronze *Banksian* medal was awarded to Mr. J. May, St. Margaret's, Twickenham, for a group of excellent *Cyclamens*, the flowers large and the plants vigorous.

## CERTIFICATED PLANTS.

*Oalanthe Halli* (W. Hall, 14, Upper Tulse Hill).—A cross between *C. Veitchi* and *C. vestita luteo-oculata*, with pure white flowers of great size and substance. They were 2½ inches across, the lip broad. The plant had two spikes about a foot long each, and four small pseudo-bulbs. It was raised from seed about six years ago, and seems as notable for its dwarf growth as the fine substance of the flowers.

*Chrysanthemum Mr. Ralph Brock'ebank* (T. Winkworth).—The beautiful yellow sport from *Meg Merrilies*, which has been repeatedly described.

*Chrysanthemum Edouard Audiguier* (J. Veitch & Sons).—A handsome Japanese variety which has been awarded several certificates, and which was recently figured in this Journal.

*Begonia Adonis* (J. Veitch & Sons).—An interesting hybrid between *Begonia John Heal* and a tuberous variety. It is fully described in a paragraph of Notes and Gleanings this week.

## CHRYSANTHEMUM SHOWS.

CRYSTAL PALACE.—NOVEMBER 4TH AND 5TH.

WHEN it was found that Chrysanthemums were so late in expanding their blooms this season, it was feared that the early shows would suffer considerably, and the Crystal Palace Exhibition was spoken of as one that would not be satisfactory. It was therefore an agreeable surprise to many to see blooms so well represented on Friday last, both in numbers and quality. The weakest portion of the Show was that comprising the incurved variety classes, but these blooms are unusually late this year. The Japanese, however, included some remarkably handsome blooms, and the four groups of plants of the same section were the best we have seen at Sydenham. The competition was keen in some of the classes for blooms, from ten to seventeen entering in several instances. Besides the competing exhibits Mr. W. G. Head, the Superintendent, had a series of tastefully arranged groups of well-grown Chrysanthemums in the centre transept and at the sides with large Palms and miscellaneous shrubs, which added greatly to the attractions of the Exhibition, imparting a furnished appearance to the surroundings.

## CUT BLOOMS.

The principal class was that for forty-eight blooms, twenty-four incurved and twenty-four Japanese, not less than eighteen varieties of each, nor more than two of one variety. The prizes were £10, £7, £5, and £3, and these substantial amounts brought ten competitors, the 480 blooms thus entered in this class making an extensive and beautiful display. Mr. C. Gibson, gardener to J. Wormald, Esq., Morden Park, Surrey, won the premier honours with a most creditable collection of flowers, comprising the following, named in the order they were arranged:—Japanese, back row: *Madame C. Audiguier*, *Maiden's Blush*, *William Holmes*, *Fernand Feral*, *Hiver Fleuri*, *Madame C. Audiguier*, *William Holmes*, *Fair Maid of Guernsey*; middle row: *Mdlle. Lacroix*, *Fernand Feral*, *Comte de Germiny*, *Mdlle. Lacroix*, *M. Ardene*, *Criterion* (very fine bloom), *Maiden's Blush*, and *M. Tarin*; front row: *Thunberg*, *Elaine*, *L'Adorable*, *M. Délaux*, *Album Plenum*, *Grandiflorum*, *Triomphe de la Rue des Chalets*, and *Golden Dragon*. Incurved, back row: *Empress of India*, *Lord Alcester*, *Alfred Salter*, *Queen of England*, *Golden Queen*, *Lord Alcester*, *Queen of England*, and *Empress of India*; middle row: *Beethoven*, *Novelty* (solid fine bloom) *Lord Wolseley*, *Golden Empress*, *Lord Wolseley*, *Refulgence*, *Jeanne d'Arc*, *John Salter* (solid handsome deep bloom); front row: *Mr. G. Glenny*, *Refulgence*, *Princess Beatrice*, *Prince Alfred*, *Barbara*, *Lady Hardinge*, *Golden Eagle*, and *Mrs. Dixon*. The Japanese were remarkably fine and grandly coloured. The incurved in the back row were not quite so deep as we have seen them from Mr. Gibson before, as they were not fully out, but the Queen type were notable for the breadth of the florets, and the two front rows comprising *Novelty*, *Refulgence*, and *John Salter* were solid well-finished blooms of great merit for such an early date. Mr. H. Shoosmith, gardener to the Rev. Canon Saltwood, Rectory, Hythe, won the second prize with very neat incurved blooms, not large, but clean and with good florets, the Japanese being bright but somewhat thinner than the third stand. Mr. J. McKenzie, gardener to T. S. W. Cornwallis, Esq., Linton Park, Maidstone, was third; some of his Japanese, such as *J. Délaux*, *Val d'Andorre*, *Belle Paule*, and *Gloriosum* were of great size and substance, but the incurved were rather rough. Messrs. W. & G. Drover, Farcham, Hants, were fourth with a stand of large Japanese blooms, but irregular incurved, and they were not put up to the best advantage.

Three classes were provided for incurved blooms, but the exhibits had evidently been contending against an adverse season, and the blooms were generally much below the standard. There were three exhibitors of eighteen incurved varieties, the prizes being secured by Mr. J. Horsefield, gardener to Lord Heytssbury, Heytesbury, Wilts; Mr. J. Snow, gardener to J. Bruce, Esq., South Park, Wadhurst, Sussex; and Mr. W. J. Smith, gardener to Mrs. Bryan, Nevill Court, Tunbridge Wells. The competition was rather better with twelve incurved varieties, six entering; but the best were small, though those which gained the first prize for Mr. T. Wyatt, gardener to J. Perry, Esq., Braddenhurst, Caterham Valley, were neat. The varieties in this stand were as follows:—Back row: *Lord Alcester*, *Jeanne d'Arc*, *Prince Albert*, and *Empress of India*; middle row: *Alfred Salter*, *John Salter*, *Queen of England*, and *Jardin des Plantes*; front row: *Mrs. Dixon*, *Mrs. G. Runle*, *Mr. Bunn*, and *Lord Wolseley*. Mr. C. Slade, gardener to Lady Bowater, Petersham, was second, *Barbara* and *Mr. Bunn* being very good. Mr. T. A. Benson, gardener to W. H. Roots, Esq., Canbury House, Kingston-on-Thames, was third. For six incurved of one variety Mr. J. Snow was first with *Jeanne d'Arc*, small but solid; Mr. G. Stevens second with *Mr. Bunn*; and Mr. J. Pannell, gardener to D. McDonald Smith, Esq., Ashley House, Caterham Valley, was third with *Lord Wolseley*.

Japanese varieties were excellently represented in all the classes, and the competition was remarkably keen; for instance, in the class for eighteen Japanese there were seventeen entries, and some were very close in merit.



Mr. J. P. Munro, gardener to E. J. D. Paul, Esq., Cambridge House, Twickenham, was placed first with large blooms of fine substance, but which had been a little too early, for some of the back-row blooms showed some fading florets. The varieties were as follows:—Back row: Madame C. Audiguier, Fair Maid of Guernsey; M. Ardene, Comtesse de Beauregarde, Meg Merrilies, and Belle Paule; middle row: Criterion, Madame de Sevin, Thunberg, Mdle. Lacroix, Baronne de Prailly, and Madame Bertie Rendatler; front row: Val d'Andorre, Hiver Fleuri, Margaret Marrouch, Feruud Feral, Comte de Germiny, and Bouquet Fait. The second prize was won by Mr. W. Packman, gardener to C. E. Shea, Esq., The Elms, Foot's Cray, Kent, who had excellent blooms of Criterion, Val d'Andorre, and M. Astorg. The third place was taken by Mr. A. Elphick, gardener to J. Clutton, Esq., The Orchards, Reigate, with Belle Paule, Val d'Andorre, Meg Merrilies, M. Astorg, and J. Délaux very notable. For twelve Japanese Mr. J. Wyatt won first honours amongst the same number of exhibitors with fresh handsome blooms of the varieties named:—Back row: M. Ardene, Maiden's Blush, Belle Paule, and Boule d'Or; middle row: Val d'Andorre, Soleil Levant, Elaine, and Madame C. Audiguier; front row: Album Plenum, Comte de Germiny, J. Délaux, and Meg Merrilies. Mr. E. Mawley, Rosebank, Berkhamstead, was second with capital blooms of Thunberg, Val d'Andorre, Elaine, Agréments de la Nature, Mdle. Lacroix, and Baronne de Prailly. Mr. J. Hewitt, gardener to H. B. Mackerson, Esq., Hillside House, Hythe, Kent, was third, J. Délaux being very fine, also Val d'Andorre of very dark colour, and Madame J. Laing unusually richly tinted. The prizes for six Japanese of one variety brought sixteen competitors, Mr. J. P. Munro winning first honours with grand blooms of Belle Paule, the best examples of this beautiful variety yet staged. They mostly exceeded 7 inches in diameter, very full, symmetrical, and with the purplish-mauve margin to the florets deep and well defined. Mr. H. Shoemith was second with Mdle. Lacroix, very handsome deep blooms, such as are seldom seen; and Mr. Packman followed with good examples of Elaine.

The reflexed variety made a pleasing display, and the sixteen stands of twelve blooms entered caused the Judges considerable trouble in determining the awards. Ultimately Mr. C. Gibson was successful with fine, clean, bright blooms arranged as follows:—Back row: King of Crimson, Cloth of Gold, Amy Furze, and King of Crimson; middle row: Chevalier Domage, Phidias, Madeleine Pezier, and Phidias; front row: Cullingfordi, Amy Furze, Felicity, and Chevalier Domage. Mr. Shoemith was second, Cullingfordi being very rich in colour. Messrs. W. & G. Drover were third.

Nine stands of twelve large Anemone blooms were staged, Mr. A. G. Hoskings, gardener to Sir H. Thompson, Hurst Side, West Moulsey, leading with good blooms. Mr. Gibson gained a similar place with twelve Pompon Anemones; and Mr. M. Sullivan, gardener to D. B. Chapman, Esq., Downshire House, Roehampton, won first honours for six Japanese Anemone, fine blooms of Ratapoi, Sœur Dorothee Souille, Madame Clos, and Margouline. Mr. G. Duncan, gardener to C. T. Lucas, Esq., Warnbam Court, Horsham, was accorded the chief prize for twelve Pompons, fresh bright blooms of good varieties.

#### PLANTS.

The groups of Chrysanthemums arranged for effect, and already noted as being an exceptionally beautiful feature of the Exhibition, were entered in the class for a group occupying a space not less than 100 square feet, Japanese varieties only, except the margin, which might consist of Pompons. Four competitors arranged groups, and so close were they in quality of blooms and taste in arrangement that the Judges spent nearly half an hour in arriving at a decision. Messrs. Davis & Jones, Lilford Road Nurseries, Camberwell, however, well deserved the premier prize they finally won, as their group was in all respects the best shown from that establishment. Conspicuous were several plants of the handsome Edouard Audiguier, the deep and distinctly coloured blooms of which contrasted well with Mdle. Lacroix; the clear yellow Mr. Garnar of a similar type occupied the centre of the group, and was honoured with a certificate; Hamlet, another good new variety with spreading florets of a reddish tinge tipped with yellow, and the brilliantly coloured Garnet added much to the group. Martha Harding, Mr. J. Laing, Val d'Andorre, and a neat bright red Pompon Délaux's Precocity were noteworthy amongst many other fine varieties. Messrs. J. Laing & Son, Forest Hill, were second with dwarf well-grown plants 2 to 5 feet high, clothed with foliage to the rims of the pots, and bearing fine blooms. The varieties were mostly those specially noted in another page, and the group was arranged with much taste, plants of this size being admirably adapted for grouping. Mr. G. Stevens, Putney, was third with a group of good plants bearing many fine blooms; and Mr. G. Edwards, Balham, had a group that was highly commended. Mr. G. Stevens also had the only group of incurved varieties, for which the second prize was awarded. The best amateurs' group in a space of 50 square feet was from Mr. W. Webster, 12, Wilton Terrace, Thornton Heath; Messrs. F. Ball and P. Cobb being second and third with bright groups.

Several classes were devoted to specimen plants, in which the leading prizes were gained by Mr. W. Clark, gardener to J. H. Lile, Esq., Devou House, Brixton Hill; Mr. C. Portway, gardener to B. B. Portal, Esq., Daventry House, Upper Tooting; Mr. A. Tomalin, Mr. A. Luff, and Mr. J. Weston.

Primulas from Messrs. Rodbourn, Welstead, Lambert, and J. Carter and Co. were good; and Mr. A. Killick, Maidstone, had a large collection of Apples; Messrs. Wood & Son, Wood Green, and Wm. Colchester, Ipswich, had stands of artificial manures, soils, &c. First-class certificates were awarded for the following:—To Messrs. Davis & Jones for Chrysanthemums Edouard Audiguier and Mr. Garnar; to Messrs. J. Laing & Son for Amy Furze and Edouard Audiguier; to Mr. T. Wulworth for Mr. R. Brocklebank; to Mr. Woodgate for C. Orchard; and to Messrs. J. Carter & Co. for Mrs. Beale, a Japanese variety with broad curving substantial florets, a most promising variety. The others have been previously described.

#### HAVANT.—NOVEMBER 3RD AND 4TH.

ALTHOUGH the general complaint of the slow progress that Chrysanthemums have made since the buds set reaches the extreme southern districts, the Havant Society can favourably compare their excellent Show of the present season with any of its previous efforts; and though only a young Society it can boast of showing its light over a large area, several of the

principal prizewinners at the larger Southampton Show hailing from this locality.

The incurved blooms showed a marked falling off both in quality and quantity, but the weakness in this section was more than balanced by the splendid quality of the Japanese varieties, many of the blooms in this section being of unusual excellence, particularly such varieties as Meg Merrilies, Fair Maid of Guernsey, Madame C. Audiguier, Thunberg, Jeanne Délaux, Marguerite Marrouch, Val d'Andorre, Golden Dragon, and Triomphe de la Rue des Châlets. The reflexed class also brought a strong competition, and included some remarkably good blooms, among others of King of Crimson, Distinction, and Cullingfordi.

**CUT BLOOMS.**—In the class for twenty-four cut blooms, distinct, twelve incurved and twelve Japanese, Mr. R. Woodfine, gardener to C. P. Boyed, Esq., Emsworth House, took the premier position, closely followed by Mr. A. Payne, gardener to Mrs. E. Smith, The Oaks, Emsworth, and Mr. C. Hoskins, gardener to G. Wilder, Esq., Stanstead. For twelve Japanese, distinct, Mr. Woodfine was again first, Mr. A. Payne second, Mr. C. Penford, gardener to Sir J. Clarke Jervoise, Bt., third. For twelve incurved, distinct, Mr. F. N. Fuller, Idsworth Gardens, Horndean, had the best stand, but was disqualified through inadvertently having two blooms of one variety, the prizes going to Messrs. Payne, Hoskins, and Roberts in the order named. For twelve large Anemones (Japanese excluded) Mr. C. Penford would have been a good first, but as the stand contained blooms of Fabien de Mediana and Sœur Dorothee Souille, this exhibitor was likewise disqualified, the prizes going to Messrs. Payne, Woodfine, and W. Roberts, gardener to E. R. Longcroft, Esq. With twelve reflexed Messrs. Woodfine, Payne, and Penford were the winners. For twelve Japanese Anemones Messrs. Payne and Fuller were first; the other prizes going as follows:—For six blooms Japanese, distinct, to Messrs. E. Smith, W. Covell, and W. Moseley, gardener to J. Taplin, Esq. For six incurved to Messrs. Covell, Smith, and Moseley. For six Anemones to Messrs. Covell, Moseley, and Hoskins. For six reflexed to Messrs. Covell and Moseley. For twelve Pompons (three blooms each) to Mr. H. Garnett, gardener to Commander Arbutnot; W. Roberts, and N. F. Fuller, all in order named.

**PLANTS.**—The principal plant class was for groups to occupy 40 feet, and the prizes were well competed for; Mr. W. Roberts having the best exhibit, followed by Mr. W. Moseley and Mr. N. F. Fuller. For eight plants, distinct, Mr. Covell took the first, Mr. N. F. Fuller the second prize. For six plants, Pompons, Mr. H. Garnett was first, Mr. W. Roberts second, and Mr. N. F. Fuller third. In the classes for single-handed gardeners the following showed some very excellent stands of blooms:—Messrs. H. Newell, H. Budd, T. Garnett, and R. S. Inthill. In the amateurs' classes the best blooms came from the Rev. R. J. Wells and Mr. J. Horril, both showing exceedingly well. In the cottagers' classes Mr. G. Kimber, Mrs. Skinner, and Walter Canner also had meritorious exhibits. Fruit and vegetables were largely shown, the competition being very keen and quality good throughout.

#### KINGSTON.—NOVEMBER 5TH AND 9TH.

A HIGHLY satisfactory Show was held as usual in the Drill Hall, Kingston-on-Thames, on Tuesday and Wednesday last, the competition being keen in all the principal classes for cut blooms, but specimen plants and miscellaneous groups were not so numerous as usual, nor were the incurved blooms up to the customary quality, though the Japanese were generally fine.

#### CUT BLOOMS.

After a long struggle Mr. C. Gibson, gardener to J. Wormald, Esq., Morden Park, succeeded in winning one of the Kingston challenge vases, and he deserves hearty commendation for the perseverance which has culminated in success. His blooms were excellent, but he did not stage them quite so well as the second prizewinner, who had elevated his blooms at the back with considerable advantage to the general effect. This is the fourth challenge vase offered by the Kingston Society, one having been won by the late Mr. Harding, two by Mr. Molyneux, and this by Mr. Gibson, who has, however, competed in the class four times. It will be remembered that the prize is offered for forty-eight blooms—twenty-four incurved and twenty-four Japanese, distinct varieties—and in the winning stand the incurved were distinguished by their neatness, breadth of florets, and solidity. The Japanese were also substantial and richly coloured. The varieties were as follows:—

**Incurved.**—Back row—Lord Alcester, Alfred Salter, Empress of India, Golden Empress, Queen of England, Bronze Queen of England, Golden Queen, and Jeanne d'Arc. Middle row—Novelty, John Salter, Princess of Wales, Lord Wolseley, Jardin des Plantes, Prince Alfred, Refulgence, and Beauty. Front row—Mabel Ward, Princess Beatrice, Golden Eagle, Lady Slade, Barbara, Mrs. W. Shipman, Lady Hardinge, and Sir Stafford Carew.

**Japanese.**—Back row—Madame C. Audiguier, Madame Lacroix, Japonais, Maiden's Blush, M. Ardene, Criterion, Belle Paule, and Fair Maid of Guernsey. Middle row—Thunberg, Hiver Fleuri, Meg Merrilies, Triomphe de la rue des Châlets, Ralph Brocklebank, Comte de Germiny, and Golden Dragon. Front row—Agréments de la Nature, Album Plenum, Boule d'Or, Marguerite Marrouch, Grandiflorum, Dormilion, Mdle. Moulise, and M. Tarin. The second prize was gained by Mr. E. Coombs, gardener to W. Furze, Esq., Roselands, Teddington, who had deep incurved flowers, but not so solid as the first; his Japanese were, however, very fine both in size and colour, especially notable being a corner bloom of Ralph Brocklebank, J. Délaux, Baronne de Prailly and Thunberg. Mr. R. Cawte, gardener to J. P. Robinson, Esq., Brookleigh, Esher, was third with good Japanese, but rather rough and irregular incurved. The fourth prize was awarded to Mr. J. Quarterman, gardener to C. E. Smith, Esq., Silvermore, Cobham, with fresh blooms. There were five competitors.

The incurved blooms were generally weak, though they were better than at the Crystal Palace. Mr. E. Coombs won the premier prize for twenty-four incurved, with fresh examples of the following, but rather small: Back row—Golden Empress, Alfred Salter, Empress of India, Lord Wolseley, Queen of England, Novelty, Prince Alfred, and Lord Alcester. Middle row—Nil Desperandum, Jardin des Plantes, Prince of Wales, Jeanne d'Aro, John Salter, White Beverley, Barou Beust, and Mr. Bunn. Front row—Cherub, Princess Beatrice, Isabella Bott, Golden Eagle, Mrs. Shipman, Refulgence, Lady Hardinge, and Princess Teck. Mr. G. Warren, Kingston, Surrey, secured the second prize; Mr. J. Carpenter, gardener to C. J.



Abbott, Esq., Rydens, Walton, was third; and Mr. J. Watson, gardener to Capt. Cundy, Southborough Park, Su biton, was fourth. The best twelve incurred was from Mr. C. Slade, gardener to Lady Bowater, Richmond Park, with good blooms of—Back row—Queen of England, Golden Empress, Bronze Queen, and Empress of India. Middle row—Jeanne d'Arc, Hero of Stoke Newington, Golden Queen, and Lord Alcester. Front row—Nil Desperandum, Jardin des Plantes, Alfred Salter, and Barbara. Mr. J. Thorne, gardener to A. E. Flood, Esq., The Bush, Walton, was placed second, but his blooms were neater and more solid than the first. Mr. R. Cawte was third, and Mr. J. W. Reed, gardener to E. Pettit, Esq., Oatlands Park, was fourth. In a class of eight competitors, Mr. J. Wilkins, gardener to J. M. Pearson, Esq., Kingston Hill, took the lead with six incurred blooms, representing Golden Empress, Empress of India, Jeanne d'Arc, Alfred Salter, Hero of Stoke Newington, and Mrs. Heale. Mr. A. Carter, gardener to Alderman Evans, Ewell Grove, Ewell, was second, and Mr. J. Buss, gardener to A. W. Aston, Esq., West Hill, Epsom, third. There being six competitors. Mr. J. Thorne had the best six incurred blooms of one variety, clean pure blooms of Empress of India. Mr. Quartermain followed with the same variety, and Mr. Carpenter with Lord Alcester. In the class for six incurred blooms from exhibitors who had never won a prize before, Mr. W. Allen, gardener to Sir G. Russell, Bart., M.P., Swallowfield Park, Reading, won the chief prize with good blooms. Mr. W. Palmer, gardener to Hume Dick, Esq., Tames Ditton House, was a good second, and Mr. W. Skeet, gardener to F. J. W. Ponsford, Esq., Littleworth, Esher, was third.

The Japanese blooms made a good display, and in the class for twenty-four distinct varieties there were seven competitors, several of which ran very close for the chief prizes. Mr. J. Munro, gardener to J. Dean Paul, Esq., Cambridge House, Twickenham, won the first prize with substantial blooms of these varieties. Back row—Belle Paule, Fair Maid of Guernsey, Comtesse de Beauregarde, Val d'Andorre, Madame B. Rndatler, Baronne de Prailly, Meg Merrilies, and Madame C. Audiguier. Middle row—Criterion, M. Burnet, Thunberg, Madame Lacroix, M. Ardene, Duchess of Albany, Magnnm Plenum, and Hiver Fleuri. Front row—Bouquet Fait, J. Delaux, Album Plenum, Comte de Germiny, M. Marrouch, Fernand Feral, Grandiflorum, Madame de Sevin. Mr. G. Warren was a close second with fine blooms, comprising M. Astorg, J. De'aux, Mrs. J. Wright, Mdle. Lacroix. Mr. J. Carpenter was third with an even stand, and Mr. G. Holden fourth. The class for twelve Japanese blooms was also a well-filled one, eight competitors staging fine blooms. Mr. J. Thorne was first with back row—Boule d'Or, Ralph Brocklebank, Trio npe de la ruede Châles, and Soleil Levant. Middle row—Fernand Feral, Madame C. Audiguier, Mdle. Lacroix, and J. Delaux. Front row—J. Latz, Golden Dragon, Baronne de Prailly, and Elaine rather poor. Mr. J. Wilkins was second, Mr. R. Carter third, and Mr. J. W. Reed fourth. All first blooms, but rather rough.

Nine stands of six blooms were entered, and Mr. C. Slade won the chief place with Meg Merrilies, Soleil Levant, Val d'Andorre, Fair Maid of Guernsey, Belle Paule, and Madame C. Audiguier, of good substance; Mr. J. Buss and Mr. Quartermain followed in the order named. Ten stands of six blooms of one variety were staged, Mr. G. Warren leading with fresh bright blooms of Fernand Feral; Mr. J. Quartermain was second with large but rough blooms of Comte de Germiny, and Mr. J. Thorne was third with a capital stand of Meg Merrilies, which we preferred to the second blooms.

Reflexed Chrysanthemums were well represented by six exhibitors, Mr. Cawte having the best twelve blooms of King of the Crimsons, Cullingfordi, Chevalier Damage being very notable. Mr. E. Coombs was second, also having good blooms of Cullingfordi, and Mr. C. Gibson third.

There were seven competitors with twelve large Anemone flowers. Mr. E. Coombs had the best blooms, good examples of Lady Marguerite, Acquisition, Minnie Chate, Gluck, Empress, and Georges Sand; Mr. Warren followed with neat blooms, and Mr. C. Gibson was third. Of the four stands of twelve Japanese Anemone Mr. G. Carpenter was first, showing handsome blooms of Mdle. Cabral, Fabien de Mediana, Madame Clos, Madame Berthie Pigny, Timbale d'Argent, and Marguerite Villageoise; Mr. C. Gibson was second, and Mr. J. Child third.

Pompons were well shown by Messrs. W. Clark, J. W. Reed, C. Slade, and W. Lemon. In several other smaller classes there was good competition. Dr. Walker, 12, Longfield Road, Kingston, was first with twelve incurred blooms, and Mr. Hawkins with six. Dr. Walker was also first with twelve Japanese blooms very creditable examples; and Mr. W. Northover, 20, Queen's Road, Wimbledon, was first with an excellent six Japanese.

The prizes for the premier incurred and Japanese blooms in the Show were awarded to Mr. C. Gibson for Lord Alcester, a clean handsome example with broad florets; and to Mr. Cawte for Criterion, a large well-developed bloom.

#### GROUPS AND SPECIMEN PLANTS.

The groups furnished some welcome colour to the Show, and arranged round the sides of the Drill Hall with the specimen plants they occupied considerable space. With a group of Chrysanthemums to occupy a space of 50 square feet, Mr. G. Stevens, Putney, won first honours with a most tasteful contribution, comprising well grown plants and fine blooms, in which Japanese preponderated. The colours were very rich, but there was also a good proportion of light tints. Mr. W. Richer, gardener to Mrs. Dunnage, Allbury, Surbiton, was second with a bright and effective group. Mr. Hawkes, gardener to G. B. Tate, Esq., Lisaine, Kingston, was third; and J. Bigwood, Esq., The Lawn, Twickenham, fourth, there being six exhibitors. An extra prize was awarded to Mr. C. Lane for a very neat and well finished group. Only one group of miscellaneous plants arranged for effect in a space of 100 square feet was entered, Mr. Filsett, Hatfield House, Twickenham, gaining the premier award with a graceful group, consisting of a groundwork of Adiantums with an edging of Isolepis, a few Palms, Crotons, Chrysanthemums, Ericas and Coleuses arising from amongst them.

Mr. R. Cawte secured first honours with six trained specimens, fine even plants, 4 feet in diameter, and bearing good flowers. The varieties were Mrs. Dixon, G. Glenny, John Salter, Prince Alfred, Mrs. G. Rundle, and Prince of Wales. Mr. J. W. Reed, had the second prize for plants of quite second-rate quality, but Mrs. Dixon was good. Mr. Cawte also had the best six specimen Pompons, free and beautiful specimens of Maria Stuart, Miss Nightingale, Brilliant, Marguerite de Coi, Mr. Astre, and Molel. Mr. Cawte

was again first with three Japanese, Marguerite Marruch, Madame B. Rndatler, and Madame Lacroix, all well flowered, followed by Mr. W. Reed. Mr. J. W. Reed had the best single specimen Pompon, a well flowered plant of Golden Madame Marthe, the best reflexed, Pink Christine, and the best Japanese, Val d'Andorre. Mr. R. Press, Cowleage, Kingston, won several prizes; Mr. W. Lemon, Kingston; Mr. Wilson, and Mr. W. Holt, Norbiton, also secured prizes. Dr. Walker, Wimbledon, showed several seedling Chrysanthemums, raised in February this year, which were commended. Mr. Elliott won the first prize for the only three standards—Mrs. Dixon, Mrs. Rundle, and G. Glenny.

#### MISCELLANEOUS.

The plants for table decoration always constitute a pleasing feature at Kingston, and staged up the centre of the tables they have a beautiful appearance. With nine plants Mr. W. Bates, Poulett Lodge Gardens, Twickenham, won the leading prize with well grown plants of Crotons interruptus, interruptus aureus, and Weismanni, Dracaena elegantissima, and two plants of Pandanus javanicus variegatus, Thrinax elegans, Cocos Weddelliana, Geonoma gracilis. Mr. H. Carter was second with graceful Crotons and Dracaenas, but a large leaved Abutilon spoiled his collection. Mr. Herbert, gardener to F. A. Davis, Esq., Anglesea House, Surbiton, was third with larger plants. Mr. J. Buss had the best six table plants, very neat. Mr. G. Holden was second, and Mr. A. Carpenter third. For six berried plants placed on the tables in a similar way, Mr. Elliott was first with six good Solanums, Mr. Cothron following with well berried Solanums, and Mr. Buss was third with Princess of Wales Capsicums.

In the fruit classes there was good competition, especially with Apples and Pears. Mr. Griffin, gardener to Miss Christy, Coombe, was first in the black Grape class with good bunches of Alicante well coloured; Mr. W. Davies, Weir Bank, Teddington, and Mr. H. Bonner, Wolsey Grange, Esher, following with Alicante and Alnwick Seedling respectively. Mr. Griffin was also first with Muscat of Alexandria, well coloured and clean, Messrs. Bates and Bonner following with the same variety. The chief prizes for Apples were won by Mr. J. Child, gardener to Mrs. Slade, Claygate; Mr. W. Bates, and Mr. J. Wilkins; for Pears by Mr. W. Davies, Mr. G. Smith, and T. A. Glover. Primulas also contributed to the attractions of the show.

For stands of flowers Miss Prior and Mrs. J. Dr-wett were the winners in the order named. Mr. W. Brown, Richmond, was first for a stand of hardy shrubs, Ferns, and Grasses, closely followed by Mr. Drewitt. Messrs. Perkins and Son, Coventry, had the best hand bouquet, an extremely graceful example, followed by Mr. W. Brown, Richmond; and Messrs. Perkins & Son were also first for buttonhole bouquets, very neat combinations of a few flowers.

A first-class certificate was awarded for *Chrysanthemum E. Molyneux* (G. Woodgate), a Japanese variety with long broad flat florets, brilliant crimson on the upper surface and golden on the reverse. If it comes with more substance this will be a good variety, for its colour is very distinct.

#### HIGHGATE.—NOVEMBER 8TH AND 9TH.

The Highgate, Finchley, and Hornsey Chrysanthemum Society held its third annual exhibition in the Northfield Hall, Highgate, London, N., on the above dates. The Hall in question is a spacious one, but the entries were so numerous that extra accommodation had to be provided in the shape of a somewhat large marque. The Show was not restricted to Chrysanthemums, classes being also provided for fruit, and sections were reserved for amateurs and cottagers respectively. Mr. Henry Barnaby was an efficient Secretary.

The open classes comprised cut blooms only. There was but one entry with twenty-four incurred flowers—namely, Mr. B. Calvert, gardener to G. K. n, Esq., Southwood, Highgate, whose stand was of good average merit, several popular varieties being well represented, and the first prize was awarded. The same exhibitor won with twelve blooms, followed by Messrs. Brittain, gardener to F. Reckitt, Esq., J. P., Caen Wood Tower, Highgate, and Mr. A. D. Clarke, gardener to W. B. Brand, Esq., Elm Grange, Finchley. Japanese varieties were best shown in the principal class (twenty-four blooms) by the last named exhibitor, his blooms being fresh and clean. Mr. Calvert followed closely, the third position being occupied by Mr. T. Taylor, gardener to J. Johnstone, Esq., Upper Terrace House, Hampstead. Two lots of twelve blooms were shown, a really excellent collection from Mr. Clark, which comprised several first rate blooms, winning with something to spare. The second prize went to Mr. Taylor, the only other competitor. Four contested with twelve reflexed blooms, and here Mr. T. Caryer, gardener to A. G. M. isner, Esq., was the most successful. He showed King of Crimsons, Chevalier Damage, and Cullingfordi remarkably well. Mr. Brittain was second, and Mr. T. L. Turk, gardener to F. Boney, Esq., Cholmeley Lodge, Highgate, third. Mr. Brittain showed Anemone-flowered varieties splendidly, and won easily. Mr. Turk being placed second. There was no other competitor.

In the second section, open to ordinary members and cottagers, the principal class was for twenty-four incurred blooms, not less than eight-een varieties, but there was no entry. Too many blooms were asked for. Even in that for twelve flowers there was but one entry, this being Mr. Brooks, gardener to Walter Reynolds, Esq., The Grove, Highgate. The stand was a good one, the flowers being remarkably fresh. First prize was awarded. Japanese were fairly shown, Mr. Calvert winning with twelve, followed by Messrs. P. Clement, gardener to S. Hicks, Esq., Springfield House, Muswell Hill, and T. L. Turk. These were all satisfactory. Pomps were fair, Mr. Newry, gardener to Rev. R. W. Powell, M.A., The Vicarage, Holy Innocents, Hornsey, was first; Mr. Brooks a very close second, and Mr. Turk third. In further classes for incurred and Japanese, restricted to single handed gardeners, Messrs. Turk, Caryer, and Newry were the chief prize takers.

Division 2, open to amateurs, provided an attractive portion of the show bringing forward many meritorious exhibits. There were four classes provided for specimen plants; Mr. Crane, 4, Woodview Terrace, Archway Road, winning with large flowering varieties—healthy, well-grown specimens, highly creditable to him as an amateur. Mr. J. Smith, Fitzroy Road, Millfield Lane, was second. The last named won with Pompons, also with a single specimen plant, another prizewinner being Mr. Murray, 2, Northwood Road, Highgate, who showed very creditably. Twelve cut blooms were best shown in this section by Mr. J. Press, 11, Victoria Cottages, Arch-

way Road; Mr. Rundle, 28, Northwood Road, and Mr. Linfield, 20, Vernon Terrace, East End, Finchley, followed. These amateurs showed exceedingly well. Mr. Sears, 43, Gordon Road, Hornsey Vale, won with six incurved, and also with six Japanese, minor prizes going to Messrs. Linfield, Press, and Crane; Mr. J. Smith was successful with Pompons. The cottagers also made a highly creditable display.

Fruit was fairly shown, six classes being provided for members and cottagers: Mr. Brittain won with three bunches of black Grapes, having capital examples, good in bunch and berry. Mr. Calvert was a fair second, and Mr. Waterworth (gardener to W. Holloway, Esq., Southwood Hall, Highgate) was third. In a corresponding class for white Grapes, Messrs. Brittain and Waterworth were first and second, both showing well-ripened bunches. Mr. J. Hutt, gardener to T. Reipath, Esq., Harriston, Hornsey, won with dessert Pears; Mr. Pink, gardener to J. Beauchamp, Esq., Newtownards, Highgate, with dessert Apples; and Mr. A. D. Clarke with kitchen Apples, minor prizes falling to Messrs. Clement, Calvert, Wilkinson, and Shepherd. Mr. Turk won with a dish of Tomatoes, Messrs. Pink and Clarke following.

Numerous special prizes were offered, amongst others a cup, value £21, the money for its purchase being bequeathed to the Society by the late Mr. J. G. Westlake. This is to be won three times before becoming the property of the exhibitor. Cash prizes were also offered by Mr. Westlake, senior. The cup is offered for the two best specimen plants, and it was won on the present occasion by Mr. J. Books with very fine profusely bloomed specimens of Mrs. G. Rundle and Bouquet Pat. Mr. Brittain was second. Special prizes were also offered, amongst others, by Messrs. W. E. Boyce for a specimen plant of the Pompon Mrs. Mardlin; by Messrs. Wood and Son for the best white Chrysanthemum fed with their liquid manure powders; by Messrs. C. L. Bush & Son for cut blooms; and by Mr. B. S. Williams for table plants. Effective miscellaneous groups were also arranged by the last-named firms.

#### EXETER.—NOVEMBER 4TH.

THE annual Exhibition of Chrysanthemums and Fruit was held in connection with the Devon and Exeter Horticultural and Natural History Society, in the Victoria Hall, Exeter, on the above date, and was considered by those acquainted with the history of the Society to be the finest autumn Show ever held in the Devon capital. The display of cut blooms was especially fine, and the same may be said of the Grapes, Apples, and Pears. The Committee and the new and energetic Hon. Secretary (Mr. G. D. Cann) are to be congratulated upon the excellent manner in which the Show was conducted.

PLANTS.—The first class in the schedule is for a group of plants in pots, not less than eighteen varieties, arranged for effect in a circle with a diameter of 8 feet, the use of Ferns for front being optional. First, Mr. J. Weeks, gardener to E. A. Saunders, Esq., with a good and tastefully arranged group, many of the plants carrying fine fresh flowers. Mr. Bartlett, gardener to Lady Hotham, was a creditable second. In the following class for a group of like dimensions, quality of blooms to be the leading feature, effect also to be considered, Mr. Prothero, gardener to T. Knappan, Esq., was first with an excellent group, containing good flowers of several popular sorts; second, Mr. Bartlett; third, Mr. Rowland, gardener to W. Brock, Esq. The last-named exhibitor was first with a miscellaneous collection of plants arranged for effect, having a very light and pretty arrangement. Second, Mr. Bartlett, whose group was not quite so light in style, but included fine Eucharis and Poinsettias. Primulas, Cyclamens, Bouvardias, Poinsettias, and plants for table decoration were best shown by Messrs. Crump (gardener to Mrs. Hart), Williams (gardener to W. Sun, Esq.), and Bartlett.

CUT BLOOMS.—There was a grand display of these. For thirty-six Japanese, in not less than twenty-four varieties, the premier position was gained by Mr. Barnes, gardener to F. C. Daniels, Esq., Stoodleigh, Tiverton, with a splendid stand, all the blooms being characterised by freshness and good colour, Belle Paule, Baronne de Prailly, J. Delaux, Mdlle. Lacroix, Val d'Andorre, and Moonlight, being all magnificent blooms. Mr. H. W. Ward, gardener to the Earl of Radnor, Longford Castle, Salisbury, was a close second, and Mr. Dolling, gardener to Mrs. Wild, was third with a bright fresh stand. Mr. McMillan, gardener to Sir George Stuckley, Bart., Moreton House, Bideford, was first for twenty-four blooms of Japanese, distinct, with a fine stand, containing good examples of Hiver Fleuri, Comte de Germiny, and Mdlle. Lacroix; the second and third prizes going to Mr. Barnes and Mr. Rowland in that order. Mr. Southy, gardener to General Hamilton, was the only exhibitor of eighteen Japanese, distinct, and he was awarded the first prize, his blooms although fresh were not very solid. The remaining prizes for Japanese fell to Messrs. Dolling, Barnes, Stiles (gardener to Mrs. Frupp), McMillan, and W. Fitzherbert, Esq. For six of any other colour Mr. Stiles was first with Madame C. Audiguer. Mr. Delors, gardener to F. W. Grant, Esq., was second with Bertie Rendatler. Three stands were put up in the class for thirty-six incurved, in not less than twenty-four varieties. The premier position was easily won by Mr. H. W. Ward with an even well finished stand, Empress of India, Golden Empress, Mabel Ward, Cherub, and Jardin des Plantes being in fine condition. Mr. Dolling was second, and Mr. Rowland third. Mr. McMillan was first for twenty-four blooms, distinct, showing Mrs. Hea'e, Jeanne d'Arc, Princess of Wales, and Empress of India in good condition; Mr. Rowland being a creditable second. Mr. Stiles was first for eighteen varieties, Mr. Southy being second, and Mr. Rowland was third. Other prizes for incurved were won by Messrs. Dolling, Southy, and McMillan. Reflexed (six blooms distinct) were shown in grand condition by Mr. Dolling, who took first prize, having, amongst others, grand blooms of King of the Crimson and Mrs. Forsyth. Messrs. H. W. Ward and McMillan followed.

FRUIT.—There was a good display of fruit. Pears and Apples being quite a feature in the Show, and the Grapes were of high quality throughout, four classes being provided for them.

GRAPES.—Mr. Pike, gardener to the Rev. H. Clark, was first for three compact well-coloured bunches of Black Alicantes, Mr. Barnes being a close second. There was only one stand of Gros Colman staged; the bunches and berries were large and fairly well coloured, and for which Mr. Sparkes, gardener to R. Barnett, Esq., was awarded first prize. Four stands of Lady Downes were put up, Mr. H. W. Ward being easily first with three good

sized and grandly coloured bunches; Mr. Sparkes securing second place. Mr. Barnes was first for three bunches of Muscat of Alexandria, showing clean well-coloured bunches; Mr. Martin, gardener to Lord Poltmore, Poltmore Park, Exeter, was second.

Mr. Bull, gardener to general Sir R. Buller, Downes, Crediton, was first with a Smooth Cayenne Pine between 7 lbs. and 8 lbs. weight; the second going to Mr. H. W. Ward for a nice fresh Queen.

APPLES.—For these sixteen classes were provided, and it would be impracticable to give details of all the awards. Mr. John Garland, gardener to Sir T. D. Acland, Bart., Killerton, Broadclist, secured first place for a collection of twenty-four varieties, staging among others fine examples of Golden Noble, Alexander, Blenheim Pippin, King of the Pippins, Prince Albert, and Warner's King; second, Mr. Williams; third, Mr. Slado, gardener to Mrs. W. H. Cook. Mr. Mairs, gardener to Sir John Shelley, was to the front with a collection of twelve varieties, his Beauty of Wilts and Cellini being remarkably good; Mr. Gibburp, gardener to Rev. Gibbs, was second, and Mr. Mortimore, gardener to Colonel White Thomson, Broomfield Manor, Exbourne, third.

Mr. Street, gardener to Colonel Walrond, was first for collection of six varieties (culinary), his best dish being Emperor Alexander. Mr. Hopkins, gardener to Major G. H. Courtenay, and Mr. Garland being placed equal second. In the corresponding class for dessert varieties, Mr. Hopkins was to the front again, being followed closely by Mr. Martin. Messrs. James Eastone, gardener to Sir John Duckworth, Bart., Wear House, Exeter; Burnett, gardener to James Searle, Esq.; Williams, Martin, Street, J. Baker, Mr. Gibburp, Mogridge, gardener to Mrs. Ord; Delne, Garland, and R. W. Baker, Esq., took the remaining prizes for Apples.

PEARS.—For nine varieties Mr. Williams was first with clean even well coloured fruit, his Pitmaston Duchess being very large and beautifully coloured. Mr. Garland was a good second. The latter was first in the next class with a collection of six varieties, his Beurré Clairgeau being very highly coloured. Mr. Burnett was a good second, and Mr. Mairs third. With three dishes dessert Mr. Street was first and Mr. Hopkins second. In the corresponding class for culinary Pears Mr. Street occupied first place again with grand dishes of Catillac, Uvedale's St. Germain, and Black Pear of Worcester, Mr. Martin being second. Several of the exhibitors already named, with Messrs. J. Hans, W. J. Baltishell (?) and Powlesland were successful in minor classes.

Messrs. Robert Veitch & Son of Exeter had a fine miscellaneous collection, comprising a good group of Chrysanthemums in small pots, a collection of Apples and Pears, and cut blooms of Chrysanthemums. Messrs. Richard Smith & Sons, Worcester, staged a magnificent collection of Apples and Pears. Mr. S. Randall of Exe Bridge, Exeter, displayed a collection of Apples and useful decorative plants; and Messrs. Stevens & Cannan put up some good stands of Japanese and incurved Chrysanthemums.

#### BRIGHTON AND HOVE.

THE fifth annual Show of the above Society was held in the Dome and Corn Exchange Royal Pavilion, and was as great a success as ever. The cut blooms especially were much better than last year, both in numbers and quality, there being over 1500 cut blooms staged in the various classes.

GROUPS.—The larger groups, 100 square feet, were arranged in circular form along the centre of the Corn Exchange, and with the Palms intermixed they had a fine appearance. The first prize was awarded to Mr. J. Turner, gardener to Major Way, Wick Hall, Hove, whose Palms were a little larger, which seemed the chief point of merit over Mr. Spottiswood's of Queen's Park, Brighton, who was second. Mr. Geo. Miles, Victoria Nursery, Dyke Road, was third with a neat arrangement of small plants. Mr. J. Bunny, gardener to W. A. Campion, Esq., Danny Park, Hurst, was first in the smaller groups, while Mr. J. Hill, gardener to M. Wallis, Esq., Springfield, Withdean was a good second. There were ten competing groups staged. Mr. J. Hill was an easy first for four standards, very good; Mr. E. Meachen, gardener to Mrs. Armstrong, Woodside, Withdean, being second. For four pyramids Mr. Meachen was first, and Mr. Hill second. The same exhibitors were first and second for dwarf trained plants. Mr. Hill was first with very neat plants. For six table plants Mr. J. Snow, gardener to J. Bruce, Esq., South Park, Wadhurst, was first with clean healthy plants. Mr. J. Turner was second, the plants being fine altogether.

CUT BLOOMS.—These were very good indeed. The chief prize of £10 for forty-eight blooms was won by Mr. Russell, gardener to Dr. C. F. Lewis, Henfield; the second was awarded to W. Jnpp, gardener to G. Boulton, Esq., Forfield, Eastbourne; Mr. J. Hopkins, High Cross, Framfield, Well-dene, Sussex, being third. The competition was very close, there were nine entries in this class. Mr. Russell was first for twenty-four incurved, closely followed by Mr. J. Snow. The first prize for twenty-four Japanese was awarded to Mr. W. F. Smith, gardener to Mrs. Byass, Nevill Court, Tunbridge Wells; Mr. Russell being second. For twelve incurved, Mr. G. Duncan, gardener to C. F. Lucas, Esq., was placed first, and in the corresponding class for Japanese first place was given to Mr. A. Emery, Alcon, Eastbourne. There was a keen competition in the classes for six blooms of various kinds, and the amateur classes contributed much to the extent of the Show. The class for six incurved, one variety, was a strong class, Mr. Russell winning with Queen of England; as was also the six Japanese, one variety, won by J. Snow with Madlle. Lacroix, very fine. There was a good display of table bouquets, an improvement on those of last year. Mr. R. Miller, Shoreham, was first. Table decorations were not numerous, but a teful. Mrs. Funnell, Tunbridge, was placed first.

FRUIT.—The entries for fruit, especially Grapes, were not quite up to those of last year. For three white bunches Mr. Duncan, Warnham Court, was first with Muscats in excellent condition; Mr. Spottiswood was a good second. There were more entries for black, chiefly Alicantes. Mr. W. Coleman, gardener to R. Potts, Esq., Bentham Hill, Tunbridge Wells, was first with well-finished Alicantes; Mr. Spottiswood second with neat compact bunches of the same; Mr. J. Duncan was placed third and Mr. Godby fourth with excellent Black Hamburgs. With four dishes of dessert Pears there was a good contest. Mr. J. McLeate of Hungershall Park, Tunbridge, was placed first with even fruits; Mr. G. Duncan was second and Mr. C. Goldsmith third. In those shown by the latter exhibitor there was a dish of Pitmaston Duchess of extra size. Mr. Bunney was placed first for stewing Pears, the variety being Catillac. For four dishes of dessert Apples Mr.



Goldsmith was first for Blenheim Pippin, Ribston Pippin, Cox's Orange Pippin, and King Pippin, all very good; Mr. Bunney was a good second. Mr. Goldsmith also took first place in the culinary class, his best dishes being Warner's King and Peasgood's Nonsuch.

**VEGETABLES.**—There was a good display, but time and space forbid giving particulars. The special prizes (for a collection of six vegetables) were given by Messrs. Sutton & Sons of Reading. Mr. Bunney was awarded first, his Anglo-Spanish Onions being particularly fine; Mr. Spottiswood's second prize collection was distinguished by remarkable fine Prizetaker Leeks. For the best specimen Chrysanthemum, prize given by Mr. F. W. Setman of Western Road, Mr. Bunney was the winner with a fine natural grown plant of Source d'Or, to which was also awarded a certificate by the National Chrysanthemum Society. A similar award was also awarded to Mr. Hill for the best standard in the Show. For twelve Cyclamens (which were very good), given by Mr. C. Kilmister of North Street, Brighton, Mr. W. M. Miles was first and Mr. Godby a good second. The prize by Messrs. Norman Bros., St. John Potteries, for twelve Primulas brought ten competitors, first honours being awarded to Mr. Bunney for good double and semi-double sorts. A first-class certificate was awarded to Mr. George Miles of Dyke Road for early flowering Chrysanthemums, Mrs. Burrell, a valuable addition to this class.

Messrs. Sutton & Sons had a large collection of Potatoes; Messrs. Cheal and Sons of Crawley had a large collection of Pears and Apples, also fine samples of their new Potato, Trusland Beauty. Great credit is due to Messrs. Balchin for the tasteful decoration of the stage and its surroundings, and to the energetic Secretary, Mr. Longhurst, and the Committee, who has made such a success by their liberal prizes and excellent arrangements.

#### NATIONAL CHRYSANTHEMUM SOCIETY.—NOVEMBER 9TH AND 10TH.

The annual Chrysanthemum, fruit and vegetable Exhibition of this Society was held on Wednesday and Thursday in the Royal Aquarium, Westminster, the numerous liberal prizes offered inducing brisk competition and an admirable display in all the sections. A very comprehensive schedule was prepared early in the year, and though the Society does not provide any sensational challenge vases, it has been found that exhibitors appreciate a substantial money prize quite as much, and perhaps more, as it requires only the one season's struggle. Four classes were included in which the first prizes were £10—namely, for a group in a space of 100 square feet, for forty-eight incurved blooms, not less than twenty-four varieties or more than three blooms of a variety, for forty-eight blooms of Japanese varieties with the same conditions, and Messrs. H. Cannell & Sons' special prize for their new Japanese varieties. Several prizes of £6, £5, and £4 are offered as the first awards in various classes, two five-guinea silver cups (or cash) were contributed by Messrs. Davis & Jones for six blooms of Mrs. Norman Davis, and Messrs. W. M. Wood & Son, Wood Green, for one trained specimen plant, six Veitch Memorial medals and money prizes being also offered for twenty-four cut blooms, incurved, Japanese, reflexed, large Anemones, hybrid Anemones, and Pompons. The classes devoted to Chrysanthemums were divided as follows:—1 to 9 for plants in pots, 10 to 34 to cut blooms open to all exhibitors, 35 to 38 amateur classes, 39 to 43 metropolitan classes.

The prizes for fruit and Potatoes were contributed by the Royal Aquarium Company, Apples, Pears, black and white Grapes, and Potatoes having eight classes devoted to them, the chief prize being £5 for twelve bunches of Grapes in six varieties, with second and third prizes of £3 and £2. Then there were two classes for collections of vegetables, in which Messrs. Sutton & Sons, Reading, offered five prizes and Messrs. Webb and Sons four prizes ranging from 3 guineas to 7s. 6d.

The exhibits were as usual arranged in the body of the Hall and in St. Stephen's Hall, and much difficulty was experienced in staging the competing plants and blooms conveniently. The energetic Hon. Secretary, Mr. Wm. Holmes, however, with the aid of a willing band of exhibition Stewards, succeeded in producing a picturesque display, though the effect would have been much heightened if the exhibits could have been concentrated in the large lower hall.

We can only briefly note the principal features of the Show this week, with the names of the most successful competitors, as the time at which we go to press on Wednesday would not permit a detailed report such as this extensive Show deserves. The National Chrysanthemum Society affords a remarkable instance of development from a local northern Society at Hackney, and the character of the exhibitions held in the past two or three years with the rapid advance in the number of members prove how well a judiciously enterprising spirit of management is recognised both by exhibitors and the public. The weather on the opening day this year was extremely unfavourable, wet, and dull.

Seven competitors entered with large groups, Mr. G. Stevens, St. John's Nursery, Putney, being awarded the first prize for a handsome group in which there was a good proportion of incurved varieties in comparison with some richly coloured Japanese. Mr. G. Edwards, Balham, was second with a bright effective group; Messrs. Davis & Jones, Camberwell, were third, also with a handsome group containing a larger number of Japanese varieties, the plants well grown and the blooms fine. For groups of dwarf plants Messrs. J. Laing & Co were first; Mr. J. Townsend, Putney, was second with a very pretty group of compact plants and good blooms; Mr. Wm. Holmes being third with neat specimens. Standard specimens were very neat and good. Mr. G. Gilbey, Clapton, had the best four plants; Mr. W. Davey, Stamford Hill, being second, and Mr. J. Mitchell, Bexley, third. For nine specimen Chrysanthemums Mr. W. Davey was first with excellent plants, followed by Mr. Portway, Upper Tooting. Mr. Lovegrove, Highbury, was accorded first honours for six standards; neat, but not large specimens. Messrs. Wood & Sons' silver cup for a specimen was won by Mr. Alfred Clerk, manager to Mr. James, Norwood, for a beautiful example of Elaine, very even and well trained.

The competition was very keen in the class for forty-eight incurved, nine exhibitors entering, the blooms generally being superior to those at Kingston on the previous day. Mr. C. Gibson, Morden Park Gardens, was again successful with neat solid blooms. Mr. Doughty, Angley Park, Cranbrook, was a very close second, and Mr. Hookings, West Moulsey, third. Mr. Gibson's stand comprised the following varieties:—Back row—Empress of

India, Golden Empress, Queen of England, Lord Alcester, John Salter, Lord Alcester, Golden Empress, Princess of Wales, Empress of India, Alfred Salter, Queen of England, Bronze Queen, Lord Alcester, Queen of England, and Golden Empress. Middle row—John Salter, Novelty, Beauty, Golden Queen, White Venus, Golden Queen, Jeanne d'Arc, Lord Wolseley, Golden Queen, Princess of Wales, Lord Wolseley, Lady Hardinge, Jeanne d'Arc, Princess Beatrice, Jeanne d'Arc, and Beauty. Front row—Mrs. Dixon, Princess Beatrice, Jardin des Plantes, Golden Eagle, Mrs. W. Shipman, Empress Eugenie, Princess Beatrice, Venus, Mrs. W. Shipman, Lady Hardinge, Barbara, Jardin des Plantes, Golden Eagle, Mabel Ward, Sir Stafford Carey, and Barbara. Three stands of twenty-four incurved blooms were entered, Mr. E. Sanderson, Harlesden, winning first honours with extremely neat fresh blooms; J. R. Wildman, Esq., Clapham Park, and Mr. A. Ives, gardener to E. C. Jukes, Esq., Winchmore Hall, were second and third.

With forty-eight Japanese blooms, Mr. W. Packman, gardener to C. E. Shea, Esq., The Elms, Foot's Cray, won first honours with a remarkably even handsome collection, comprising the following varieties:—Back row—Fair Maid of Guernsey, Val d'Andorre, Golden Dragon, Triomphe de la Rue des Châlets, Mdlle. Blanche Pigny, J. Delaux, Thunberg, Belle Paule, Mdlme. B. Reudatler, Baronne de Prailly, Boule d'Or, Mdlme. C. Audiguier, Fair Maid of Guernsey, Val d'Andorre, Soleil Levant, and Madame C. Audiguier. Middle row—Mdlme. J. Laing, Meg Merrilies, M. Tarin, Comte de Germiny, Soleil Levant, La Triomphante, Japonaise, M. Astorg, Red Gauntlet, Criterion, Mdlle. Lacroix, Mdlme. B. Reudatler, Red Gauntlet, Comte de Germiny, Elaine, Mr. J. Laing. Front row—Elaine, J. Delaux, Criterion, M. Astorg, M. Delaux, Mr. J. Laing, Peter the Great, La Triomphante, Martha Harding, Mr. J. Laing, M. Delaux, Fernand Feral, Thunberg, Maiden's Blush, Belle Paule, and Golden Dragon. The second prize was awarded to Mr. J. McKenzie, Linton Park Gardens, Maidstone, and the third to Mr. C. Gibson.

Mr. W. Elphick, The Orchard Garden, Reigate, was the most successful with twenty-four Japanese, followed by Mr. J. Brown, Great Doods Gardens, Reigate, and Mr. J. Child, Esher. There were ten stands of twelve Japanese, Mr. J. Bettsworth, Cheshunt, leading; E. Mawley, Esq., second; and Mr. J. Hewett, Hythe, third. For six of any white Japanese variety, Mr. W. Green, Barnet, was first with fine Elaines; Mr. D. Hill following with Mdlle. Lacroix; and Mr. Wildman with Elaine.

The reflexed blooms were well shown, the chief prizes being secured by Mr. Hookings, West Moulsey; Mr. H. Moore, Bexley; Mr. W. Wildsmith. Mr. Sullivan had the best stand of twenty-four hybrid Anemones, and Mr. G. Duncan of Pompons. There were several other classes for Japanese and incurved, in which we could not obtain the awards, but we shall have occasion to refer to them in another issue.

#### FRUIT AND VEGETABLES.

The best collection of twelve bunches of Grapes was shown by Mr. W. Pratt, Longleat Gardens, who had large bunches of Alicante, Muscat of Alexandria, Gros Colman, Trebbiano, and Lady Downe's. Mr. W. Allan, Gunton Park Gardens, followed with fine bunches, but not quite coloured, of Black Morocco, Alicante, Mrs. Pince, Gros Maroc, Lady Downe's and Muscat of Alexandria. Mr. J. Wallis, Keele Hall Gardens, was third: Mr. A. Smith, Loughton, had the best three bunches of black Grapes, Gros Colman very handsome. Mr. S. Castle, West Lynn, was second with the same variety, and Mr. T. Osman third. Mr. W. Pratt was first with white Grapes, Muscat of Alexandria beautifully coloured. Mr. F. Lee, Mundford, Norfolk, second with the same variety, and Mr. G. Duncan, Horsham, third.

Fourteen collections of six dishes of dessert Apples were shown, Mr. R. Dean, Ealing; M. J. McKenzie, Linton Park Gardens; and Mr. Goodacre, Elvaston Castle Gardens, being the prizewinners in that order. There were also ten competitors with six dishes of culinary Apples, Mr. J. McKenzie leading with grand specimens, followed by Mr. C. Ross, Welford Park Gardens, and Mr. A. Smith, Warren Hill, Loughton.

Pears were not so numerous, but there were ten exhibits of six dishes dessert varieties, Mr. Wm. Allan, Gunton Park Gardens, securing the premier award: Mr. C. Goldsmith, Kelsey Manor Gardens, Deckenham, and Mr. T. Osman, Chertsey, being second and third.

With twelve dishes of Potatoes there were seven exhibitors, Messrs. E. Chaffing, Ellington, and E. S. Wiles, winning the honours in the order named, while of the ten collections of six dishes Messrs. Ellington, C. Ross, and F. Miller were the winners.

Messrs. Sutton's prizes were won by Mr. J. May, Barnet, and Mr. T. A. Beckett, Amersham; Mr. C. J. Waite, Esher; Mr. Wm. Pope, Newbury. Messrs. Webb's prizes were won by Mr. Wm. Pope, Mr. G. Haines, Highworth; Mr. J. May, and Mr. C. J. Waite.

#### MISCELLANEOUS.

Messrs. G. Bunyard & Co., Maidstone, Kent, had a most extensive exhibit of Apples and Pears, 150 dishes, besides a dozen baskets of grand specimens of Blenheim Pippin, Gascoigne's Scarlet Seedling, Warner's King, Cox's Pomona, Lord Derby, Peasgood's Nonsuch, and other. All the fruits in this collection were exceptionally fine. Messrs. Sutton & Sons, Reading, had an exhibit of Potatoes, representing thirty general varieties, besides twenty-two sent out by this firm, and a number of seedlings. All the samples were remarkable for their even size and good appearance. Messrs. Webb & Sons, Wordsley, Stourbridge, showed fifty dishes of Potatoes, including the selected varieties sent out by themselves. Mr. C. Fidler, Reading, also had a large collection of Potatoes.

Messrs. H. Cannell & Sons, Swanley, had a magnificent exhibit of Chrysanthemum blooms, with Zonal Pelargoniums and other plants. Mr. H. G. Smyth, Drury Lane, also had a stand of peat, soils, manures, &c. Messrs. Wood & Son, Wood Green, had a stand of horticultural sundries, manures, &c. Mr. James George, 10, Victoria Road, Putney, showed samples of peat, Mushroom spawn, tobacco paper and cloth, Thomson's manure, and fine Gros Colman Grapes. Mr. B. Field, Queen Victoria Street, had a stand of horticultural sundries; and Mr. W. Colchester, Ipswich, had a stand of manures and horticultural sundries.

**FLORAL COMMITTEE.**—Present: Mr. E. Sanderson, in the chair; and Messrs. T. Bayan, Lewis Castle, R. Dean, S. Gilbey, C. Gibson, J. P. Kendall, G. Langdon, R. Owen, G. Stevens, and C. Swift. There were



numerous exhibits before this Committee, novelties being more numerous than at any previous meeting this season. Certificates were awarded for several varieties of considerable merit, and Mr. G. Stevens obtained another silver medal for a stand of new varieties, Mr. R. Owen of Maidenhead securing a bronze medal for a similar stand, in which the blooms were not so large. Mr. Elliott of Jersey sent a large collection of seedlings raised this year. They were most varied in character, and the Committee thought them very interesting, desiring to see the best of them again another season. Mr. Addison, Maud Villas, Parchmore Road, Thornton Heath, exhibited blooms of Dr. Besancele sent out by Bonamy three or four years ago, and which has reappeared under the name of *Le Reveil* from Délaux this year.

Certificates were awarded to the following:—

*Mrs. M. Russell* (M. Russell, Henfield).—A sulphur coloured sport from the Anemone Madame Goderau, considered very promising.

*Lord Eversley* (Stevens).—A neat incurved, white sport from Princess Teck certificated last year at Reading.

*Thorpe Junior* (Shoemich and Pearson).—A large Anemone of rich golden colour, a handsome bloom of good size with broad guard florets and a high centre.

*Gorgeous*.—(J. P. Kendall).—A golden yellow Japanese of the Thunberg style, with long twisting florets.

*Sarah Owen* (Owen).—A sport from the Japanese Madame J. Laing, golden, with slight bronze tint. Very promising.

*Amy Furze* (reflexed), *E. Molyneux*, *Charles Dickens* (Veitch), *Mrs. Beale* (Carter); and a few others were honoured that have been previously noted.

#### CROYDON.—NOVEMBER 9TH.

INCREASING entries and a desire to cater for public patronage by the attraction of a band this year, induced the Croydon Horticultural Society to seek more commodious premises for its annual Exhibition of Chrysanthemums than it has had in former years, the large Public Hall in George Street being requisitioned. Unfortunately, though the Exhibition, as such, was a success, the quality of the blooms being excellent, exceedingly unfavourable weather militated against a satisfactory attendance. The principal awards are appended:—

The chief class for incurved (twenty-four blooms) in the open classes produced a surprise in the defeat of the Surrey champion, Mr. C. Gibson, gardener to J. Wormald, Esq., Morden Park, Mitcham, who could only secure second place to Mr. J. Wyatt, gardener to J. Perry, Esq., Bradenhurst, Caterham Valley. The latter had a stand of fresh good sized blooms excellent examples of *Jeanne d'Arc*, *Jardin des Plantes*, and *Lord Wolseley* being the most conspicuous. Mr. Gibson's best blooms were, it was evident, elsewhere, those in competition, though large, being somewhat rough and irregular. The back row flowers were good, notably *Alfred Salter*, *Jeanne d'Arc*, and *Empress of India*. Mr. King, gardener to Philip Crowley, Esq., Waddon, was third, two others competing. In the corresponding class for Japanese the last named was more successful, taking first place from Messrs. Wyatt and Gibson. *Val d'Andorre*, *Triomphe de la Rue des Chalets*, and *Soleil Levant* being perhaps his best blooms. There was but one entry with reflexed flowers, Mr. Gibson, to whom the first prize was awarded for a meritorious stand. Mr. J. R. Box, North End, Croydon, had the best group, Mr. W. Curd, George Street, Croydon, taking second place. The latter had the more diversified arrangement, the former the best blooms. Mr. King won with foliage plants; Mr. H. Alderman, gardener, Morden Hall, second; and Mr. Rodbourn, gardener to Baroness Heath, Coombe House, third.

Competition with cut blooms was not very brisk in the classes reserved for gardeners and amateurs practising within a radius of four miles of the Croydon Town Hall. Mr. E. Stew, gardener to E. Parritt, Esq., Lower Addiscombe Road, was the solitary exhibitor of twenty-four incurved, and received the premier award. With the same number of Japanese Messrs. R. Ridger, gardener to Lady Ashburton, Addiscombe, and R. Haynes, gardener to Miss Freeman, South Norwood Hill, had the field to themselves, and were placed first and second in the order given, nothing in the stands calling for special comment. Mr. Rodbourn had a remarkably even stand of twelve incurved, *Prince Alfred*, *Lord Wolseley*, and *Jeanne d'Arc* being well represented amongst others. First prize was awarded. Messrs. Welstead, gardener to Mrs. J. Lodge, Branley Hill, and J. Lover, gardener to M. Hodgson, Esq., Shirley Cottage, were second and third. Mr. Steer won with twelve Japanese, Messrs. Rodbourn and Lane, gardener to Mr. Alderman Burrow, J.P., Park Hill, securing the remaining awards. Prizes in other classes for incurved and Japanese were won by Messrs. Tilbury, gardener to C. Legg, Esq., J.P., South Norwood; Staines, gardener to J. Newton, Esq., J.P., Park Hill; W. Jupp, gardener to C. Johnson, Esq., The Waldrons; Dyer, gardener to G. Parsons, Esq., Selhurst Road; C. S. Bowman, London Road; and Hazell, gardener to J. R. Frewer, Esq., Lower Addiscombe Road, besides others already named. There was only one entry for twelve Anemone-flowered and twelve Anemone Pompons respectively, Mr. Rodbourn being awarded the first prize in the first, and Mr. Dohson, gardener to Miss Stenning, Addiscombe Road, in the second. Both were good stands



#### HARDY FRUIT GARDEN.

PLANTING FRUIT TREES.—Much depends upon the proper preparation of the ground for young fruit trees, these being of a too valuable nature, and occupy one site too long to be planted in a haphazard fashion. We do not advocate preparing the holes before the trees are received, for the simple reason that newly moved soil is liable to become badly saturated during a few hours of rainfall, in which state it is totally unfit to receive the roots of fruit trees. It is a wiser course to

lay the trees in by their "heels" directly they are received, properly planting them as fast as the holes are ready. The drainage ought first to be seen to. Most kitchen gardens are sufficiently well drained, an addition to the number of drains in such cases being calculated to do more harm than good. A deep drain, or say about 3 feet below the surface, taken along the front of a wall border, or close to the walk, will do good service, especially when the subsoil is of a retentive nature. On no account would we take a drain immediately under trees, this carrying off moisture that is much needed at times. A single deep drain is capable of drawing off all superfluous moisture a distance of 10 feet on either side. Nor do we discover any advantages attending the introduction of a quantity of rough stones in the bottom of a hole formed for the roots of a fruit tree. They seem to encourage rather than check deep root action, and are very much in the way when lifting and root-pruning becomes necessary in order to induce fruitfulness, or the formation of sounder better fruit. In all cases carefully avoid low and also deep planting. If the soil is broken up two spits deep, and which is advisable where the subsoil is a fertile or fairly free-working nature, this will sink considerably and the tree with it. In the case of clayey subsoils we would either remove these as much as possible, substituting the best loamy soil procurable, or only lightly fork it up in order to assist the drainage. Do nothing to encourage the roots to ramble into such stuff, but rather make the surface soil more attractive, and, above all, plant high. Holes a little larger than the spread of roots are unsuitable, especially in the case of retentive soils. Let the holes be at least 4 feet in diameter, quite the largest trees needing them still larger. Remember it is not merely for one year but for many years that the site will be occupied, and the better the roots are treated the more likely that good crops will be secured. Each tree ought to have its roots examined prior to planting, it being advisable to cut away all bruised or cut portions, and all the broken points cleanly cut over. A clean cut always heals more rapidly than a bruise or break of any kind. Many of the trees received from the nurseries have their roots all matted together, this being the result of faulty planting. They should be spread out flatly and thinly into the fresh soil, or much as they start from the underground portion of the stem, a little of the best soil or some fine compost being rather firmly disposed about them. When finished off the topmost roots ought to be no more than 4 inches from the surface, while the "collar" of the tree, or that portion nearest the roots, should in most cases be at least 6 inches above the ordinary level. This allows for sinking, and if eventually they remain above the level so much the better for the tree and its owner. Exposed trees to be staked up at once. Apricots against walls on heavy soil ought always to be planted high, and Peaches and Nectarines also thrive well when well raised. It should also be added that all fruit trees are benefited by a liberal addition of turfy loam, crushed bones, and burnt garden refuse to the ordinary soil; but it is the wall trees that usually stand most in need of it, owing to the same sites being so long occupied, perhaps for a century, with fruit trees, many of which have been dead and burnt before the present owners of the garden were in possession.

DISTANCES AT WHICH TO PLANT.—Fan-shaped Peaches and Nectarines for walls may be about 15 feet apart, 20 feet not being too much where they succeed well. High walls can be better or more quickly furnished by planting both dwarf and half-standard trees alternately, in which case the dwarfs may be disposed 20 feet apart, and the half-standards or "riders" midway between them. Apricots grow to a larger size than Peaches, at least in gardens where they thrive, and these may well be planted a distance of from 15 feet to 20 feet apart, and 24 feet apart, if half-standards are mixed with the dwarfs. If they do not last long plant them about 8 feet apart and train to a single stem—a system to be described more fully later on. Espalier or horizontally trained Pears, either on walls or along the garden walks, if on the Pear stock to be 15 to 20 feet apart, but if on the dwarfing or Quince stock a distance of 10 feet to 12 feet apart is ample. Pyramidal Pears on the Pear stock and encouraged to extend to their full size to be about 12 feet apart, but if restricted both at the top and roots 8 feet apart is sufficient space. On the Quince stock and not root pruned they may be planted 6 feet apart, and root-pruned 4 feet apart. Double oblique and upright cordons 2 feet apart and single cordons somewhat closer. The five-branched vertical cordons, one of the best methods of training Pears, ought to be disposed not less than 5 feet apart. Standard Apple trees, these always being best on the natural or Crab stock, may be planted 24 feet apart each way, or rather more if fruit bushes are to share the quarters with them. Horizontally trained Apples on the Crab stock to be 15 feet apart, and on the Paradise or dwarfing stock 12 feet apart. Single horizontally trained cordons to be 12 feet apart, and the double horizontals about the same distance. Pyramidal and bush-trained Apples on the Crab stock to be from 10 feet to 15 feet apart, and on the Paradise stock 3 feet to 4 feet apart. Fan-shaped Plums on walls ought to be from 15 feet to 20 feet apart, pyramids being 8 feet, and standards 24 feet apart, Cherries being given about the same distances. Black Currants, Red Currants, and Gooseberries may be disposed either among standard fruit trees or in a quarter by themselves. They ought to be 4 feet apart from row to row, the same distance dividing them in the rows.

#### FRUIT FORCING.

PEACHES AND NECTARINES.—*Earliest Houses*.—To have fruit ripe in April houses that are planted with Alexander and Waterloo Peaches may be closed about the middle of this month, fire heat not being applied until the beginning of December. Desirable, however, as are those varieties for forcing to afford very early dishes of ripe fruit, it must be

borne in mind that they have not the quality of Hales' Early, Stirling Castle, or Royal George, which started at the same time will not afford fruit until May. The house may be kept close, but admitting air freely above 50°, employing fire heat only to prevent the temperature falling below 35°. The more slowly the trees are excited the stronger will be the blossoms. The outside border must be well protected with litter or dry fern, and if wooden shutters or tarpaulin are available they will be advantageous in throwing off excessive wet. A thorough soaking of water should be given to the inside borders, and if the trees are weakly a soaking of liquid manure not too strong will tend to a more vigorous break. Sprinkle the trees in the morning and afternoon of bright days, but do not keep them dripping with moisture.

**Succession Houses.**—All the leaves are off, except in the latest house, where they should not be forcibly removed, at least not until they part readily from the trees, but when they are all off or come easily by brushing with the hand or a light broom, unfasten the trees from the trellis, prune them, thoroughly cleanse them and the house, and if need be paint the woodwork and trellis. Tie the trees to the trellis, leaving room for the branches to swell, tight tying being inducive of gum. Remove the surface soil and supply fresh, give a good watering to the inside borders, thereby having all in readiness for a start when required. The houses should be kept as cool as possible.

**Lifting, Root-pruning, Fresh Trees.**—Any lifting, root-pruning, or the introduction of fresh trees should be performed at once, the planting being proceeded with as soon as the leaves are nearly off the trees to be removed. Trees for planting in houses are best three to five years trained and prepared for lifting by digging round them a year previously. Such trees can be lifted with an abundance of fibres, and being carefully planted they force well the first season, not being brought on too rapidly, and a moderate crop taken. It is always best to select such trees in preference to planting young ones, which do not fruit much the first two or three years, hence the advantage of planting trees in an already bearing state.

**Figs.**—*Early Forced Planted out Trees.*—These should now be nipped from the trellis and pruned. Those with the roots restricted to small borders will require the shoots thinned where too crowded, but those not having the roots restricted will need a hard pruning at the upper part of the trellis, cutting back those shoots that have reached to the limit, to where the succeeding shoots start. Remove any elongated spurs, reserving such as are short-jointed and fruitful. The house should then be thoroughly cleansed, washing the woodwork with scalding water, washing the walls afterwards with quicklime and sulphur. Wash the trees with soapy water, and afterwards dress with an insecticide. Then secure the trees to the trellis, allowing room for the growth of the branches, forking the surface of the border slightly, removing the loose material, and apply a top-dressing of short partially decayed manure, about 3 inches thick, giving a good watering. Ventilate freely at all times, except when frost prevails, which it is well to exclude.

**Succession Houses.**—Prune and cleanse the trees without delay especially where insects have obtained a footing. Complete any root-pruning, lifting, &c., remembering that Figs with the roots restricted or confined to limited space are more manageable and fruitful than those with an unlimited root area. Any unfruitful trees should be rather severely root-pruned, and the roots restricted to moderate-sized borders, depending more upon active feeders near the surface encouraged by mulching than a large extension of roots.

**STRAWBERRIES IN POTS.**—One of the greatest errors in growing Strawberries in pots is placing them in Peach houses and with open ventilators, where from the passing currents of air evaporation is constant and excessive, which only wastes the energies of the plants, and not unfrequently destroys the root at the sides of the pots. All plants for early forcing should be in frames, with a view to protect them from heavy rains only. Those for midseason and late forcing are just as well plunged in ashes in a sheltered situation as anywhere, having a light covering of bracken or straw in severe weather. Drought is the great bane of the Strawberry, therefore those in frames must never be neglected, the soil always being kept moist. Plants of *La Grosse Sucrée*, *Vicomtesse Hericart de Thury*, or other early sorts must be held in readiness for placing in the early Peach house, to which fire heat will be applied early next month, or in the Strawberry house if one exist. In a season when the plants are late it is advisable to make up a bed of leaves about 2 feet in height, and place the plants in a frame upon it, packing the spaces between the pots with damp leaves. The bottom heat at the base of the pots need not exceed 65°, the top being kept cool, 50° not being exceeded, and when mild draw off the lights. This will tend to promote activity at the roots and to push the crowns. After three weeks to a month of this treatment the pots must be withdrawn or raised if the bed be still warm, so as to insure the plants bearing the temperature of the Peach house or Strawberry house without check, as would be the case were they taken from a warm bed direct to the shelves. Plants for placing in vineries to be started next month require similar treatment. In case of plants having well developed crowns and abundant roots the slight bottom heat is not necessary.

Those having the convenience of a house for forcing Strawberries will find it a considerable advantage (in seasons like the last) to start the plants in bottom heat, and if a pit be employed having artificial heat, so as to maintain the top heat at 50° in severe weather, keeping them in it until the trusses are pushed clear of the crowns before removing them to their fruiting quarters. Time will be gained, as late plants (and all are late this season) will need very careful treatment to secure a satisfactory result with the first early-forced plants. If worms

have gained an entrance to the pots dislodge them with lime water rectifying any defects of drainage.

**PINES.**—Liberal ventilation should be afforded to houses or pits containing young plants whenever the weather is favourable, and avoid damping, as keeping the houses constantly saturated is more injurious than otherwise. Water will be required frequently, yet the plants must be examined every ten days, watering such as require it, as too great dryness is more prejudicial than is commonly supposed. In the fruiting department lose no opportunity of closing the house at 85°, keeping the night temperature at 70°, or a few degrees less in cold weather. Remove all the superfluous suckers, retaining one only, the best on each plant. Suckers on successional plants that appear before the fruit is visible should be removed, unless an increase of stock is urgent. At this time of year it is usual to make new beds of fermenting materials for the young plants. Tan is unquestionably the best material, a good substitute being found in Oak or Beech leaves, which should now be collected as dry as possible. In forming beds of leaves they should be firmly pressed; tan, on the other hand, should be placed lightly together.

**CUCUMBERS.**—Maintain a night temperature of 70°, a few degrees less in severe weather, advancing to 80° and 85° with sun heat. Admit a little air at the top of the house whenever the weather is favourable, but it must be done without lowering the temperature, it being better to shut off the top heat for an hour or two when the sun is powerful than to admit air when the winds are sharp and cold. Moderate ventilation is, however, beneficial in carrying off steam or accumulated moisture. The syringe may be laid aside except for damping the paths' walls, &c., in the morning and afternoon in warm bright weather, keeping the evaporation troughs filled with liquid manure. The water or liquid manure given to the roots must be of the same temperature as the house, as also must the soil that is added to the beds.

The autumn fruiterers being now in full bearing must not be over-cropped, therefore remove the fruit as soon as it attains a fair size, and all deformed fruit when seen. Examine the plants at least once a week for the removal of bad leaves, stopping or cutting away superfluous growths.

Let the winter fruiterers advance well up the trellis before stopping them, training the side growths evenly, and not more closely than to allow of the foliage being well exposed to light. Stop at a few joints of growth, or one or two joints beyond the show of fruit. Allow few or no male blossoms or tendrils, removing them as fast as they appear, and add fresh warmed soil as often as the roots have fairly covered the surface of the bed.

#### PLANT HOUSES.

**Lilies.**—The various Lilies that are used for decoration in pots and have properly ripened their flower stems need attention at once. More of these plants are ruined during the season of inactivity, through being kept too dry, or too wet, than by any other cause. To grow these plants well, they should be so accommodated that they will need no water from the present time until growth commences at the top of the bulbs. During this time they must not be dry, but the soil in an intermediate state. If the old flower stem is thoroughly ripe, it may be removed and all the old soil above the bulb, and if the remainder of the soil is sweet, and the drainage clean and good, they will only need supplying with a rich top-dressing of good loam, one-seventh of decayed manure and sand. Annual pottings is not needed with those that have ample room at their roots—for instance, *L. lancifolium album* and *rubrum* will do well in the same pots for years. Those, however, that need larger pots should have the drainage and all loose or sour soil removed, and then be placed into a size larger. If the loam is of a heavy nature one-third of leaf mould may with advantage be added. The roots should not be disturbed, for injury to those that are plump and healthy will be certain to tell against the plants next season. Be careful that the soil of the old ball is in an intermediate state for moisture when potting is done, and the new soil should be in the same condition. Plunge the pots in a cool shed or cold frame, where the plunging material will protect them from frost and prevent the evaporation of moisture. If the surface of the soil and rim of the pots are buried beneath 2 inches of ashes the bulbs will remain in a capital condition until they commence root and top growth early in the season. Bulbs that are potted for the first time should be subjected to the same treatment, only a little sand should be placed at the base of each bulb as they are potted.

**Lilium candidum.**—This variety, *Harrisi* and *longifolium*, that have been forced in previous years must be grown for a time in the greenhouse or other position close to the glass where they will be safe from frost; in fact, the temperature should not fall below 45°. They must be kept growing slowly, so that undue forcing to bring them into bloom early in the season need not be resorted to. Any of these potted for the first time may be plunged in cold frames. The leaves of *L. candidum* will be developed, and, therefore, this variety should not be plunged too deeply to injure the foliage. Our newly potted bulbs of this variety were plunged when potted, and, therefore, their foliage has been developed through the plunging material in a natural manner.

**Preparations for Forcing.**—A good supply of leaves in a dry state should be stored ready for making up fermenting beds in which to plunge various hardy flowering shrubs to bring them into flower. The moist gentle heat afforded by leaves is most beneficial in bringing forward various plants. If the house to be set apart for forcing operations has been thoroughly cleaned, leaves may be wheeled in and a bed made up without further delay. Early Hyacinths, Tulips, Narcissus, *Azalea indica*, and other plants that are ready may be stood upon the surface. The gentle heat produced by the leaves will be ample for the plants at first without resort to the hot-water pipes unless sharp weather should



set in early. Callas, if needed early, come forward in a position of this description very quickly, especially if their pots are plunged.

## THE BEE-KEEPER.

### PRACTICAL BEE-KEEPING.—No. 22.

In the old days, when the price of honey was comparatively high, and there was a ready market at the then current price for all available surplus of good quality, it was customary to advise all bee-keepers who desired to obtain a maximum of profit from their stocks to deprive them very closely at the end of each season, and to give a sufficient supply of syrup to take the place of the honey so extracted to last each stock until the end of March or beginning of April. A change has of late come over the aspect of affairs, a black cloud has somewhat dimmed the rising sun on the bee-keeper's horizon, and a changed policy will commend itself to all those practical bee-keepers who are ready to meet new wants and present requirements by a change of system and ideas. In those old days, when the price of honey was relatively high compared to that of sugar, it was undoubtedly a very profitable practice to deprive each stock of all its honey and then to feed with sugar syrup until a sufficient supply of artificial store had been given. In isolated instances and in bad seasons when honey is scarce and a good price can be commanded, the system of total deprivation will still commend itself, but unless honey is readily saleable at a fairly remunerative price it is folly to pursue the practice. In the vast majority of instances the price of honey is so reduced that—taking into consideration the loss occasioned by feeding, by the process of storage in the cells, and evaporation before sealing, by loss of energy and therefore prematurely shortening of bees' life, and by the labour which the bee-keeper must expend in taking the honey-making syrup and feeding it to the bees—the margin of profit is so small that, especially in view of the state of the honey trade, it seems suicidal to throw an extra surplus upon an already overstocked market.

Every bee-keeper is beginning to feel more keenly the wide-spread depression which extends throughout the land, and affects in a greater or less degree every trade industry and profession. The gradual but long continued drop in prices has very considerably affected the position of the practical bee-keeper, and if he does not desire to find himself left stranded on the shore by the wave of remorseless competition he must at once exert himself in every possible way to combat low prices, not only by a cheapened production, but also by paying due regard to certain points in the management of the apiary and the sale and creation of surplus which have hitherto in this country escaped the notice which their intrinsic importance demands in view of the present crisis. The cause of the present low value of honey is that production has been increased, while the demand for the commodity has not increased in anything like the same ratio. This increase in production without a correspondingly increased demand has had the natural effect of depressing the market to the advantage of the consumer at the expense of the producer. Added to this, there has been for years a very considerable importation of honey from the Colonies, America, and other countries, which has—on account of the low prices which the foreign production has realised—considerably increased the exigency of the situation. A more equal adjustment of the balance of supply and demand can alone in future regulate prices. If this adjustment cannot in a short time

be effected by a determined attempt to extend the consumption as well as the production of honey, many a bee-keeper will find that he is producing at a loss, and will consequently retire and take up some new industry which seem to afford him a better chance of making a profit by his exertion. If there is a practically unlimited supply, and only a relatively small demand, the market must be glutted, and prices will consequently recede to a point which will in the majority of instances absolutely preclude the possibility of making the management of an apiary a profitable undertaking. Even now the supply is practically unlimited, while the demand is comparatively small and increases very slowly.

Without in any way taking a pessimist view of bee-keeping it is impossible, and if it were possible it would be most unwise, to take a rose-coloured view of the present state of the industry; it is wiser to look facts in the face and endeavour to meet the exigency of the moment by changing our management. By this depriving system a large extra surplus is thrown upon a market already glutted. Bee-keepers who have the greatest difficulty in effecting a sale of their surplus honey proper, take this extra surplus for the sake of a possible chance of making an extra profit, forgetting that as things are at present there is more than a possibility of reaping a loss. Does it not seem suicidal to add to an already overstocked market an additional weight of honey which can never at the present relative prices of sugar and honey yield a fair profit? Is it not a wiser policy to leave the bees sufficient to supply their wants until another summer, and be content with taking as a surplus that honey only which remains over and above the amount required for the preservation of the stocks in the winter and spring? There has been considerable discussion on this point in America, and the opinion of those who ought to be able to decide the question on a profit and loss view of the matter seems to be strongly against the purchase of sugar for feeding purposes when honey is in any case scarcely saleable at a price which will remunerate the bee-keeper for his trouble, and in many instances is only saleable at a price which will entail upon him positive loss. But in the United States they have also, in forming an opinion upon the point, to deal with the question of adulteration, which has of late apparently assumed a somewhat serious aspect owing to the fabrications of persons who have attempted without a shadow of justification to condemn section honey as a product of machinery, and therefore a fraud. Apparently it is decided, if we may judge from the "American Bee Journal," that when honey is low in price and not very readily marketable even at that low price, it is little short of madness to deprive stocks and then to feed them up into sugar. By doing so not only is the honey market glutted to a greater extent than is at all necessary, but the sister industry of the sugar boiler is assisted by his competitor, the bee-keeper, to the manifest disadvantage of the latter. When honey is plentiful it can only be sold at a price which leaves a very small margin of profit, and even this small profit sometimes entirely disappears. If, however, the purchase of sugar for feeding purposes was stayed, and the requisite amount of honey for keeping the stock in health were withdrawn from the market, it would be far less difficult to dispose of first-class honey at a price far more satisfactory to the bee-keeper. At present we have not to contend in any great degree with the suspicion of adulteration, but the consumption of large quantities of sugar in the apiary at the very time when the surplus is being taken does often cause suspicion, and therefore gives an



impetus to the childish jokes by which certain ignorant people across the Atlantic attempt to ruin an honest industry in which many of their countrymen are engaged. At the present time many of the bee-keepers of my acquaintance are unable to effect a sale of their honey, and yet they have deprived their stock very closely. To do this they have had to expend a considerable amount of time, to purchase a large quantity of sugar, and have on hand a fictitious surplus which they may very possibly be compelled to use in the apiary. They have therefore lost very considerably. On the other hand, in certain instances where care has been taken to discover a market before taking the honey from the stocks a fair profit has been left to pay for the labour.

To those bee-keepers who find a difficulty in disposing of their ordinary surplus at a remunerative price, my advice is not to closely extract from the combs of the hive itself, but to leave sufficient in every case to keep the bees until spring. That honey only can be considered surplus which is the overplus of food required by the bees themselves. If the bee-keeper can make a profit by also taking the supply of honey left for the support of the bees, and supplying them with syrup at a profit to himself, he will doubtless pursue that policy with advantage; but if he is unable to effect the exchange at a profit he is not only injuring himself but he is also doing a great injury to others by glutting the market with a fictitious surplus, and thereby reducing prices, and rendering bee-keeping a more precarious undertaking by increasing the supply when there is no demand.—FELIX.

#### BACILLUS MINOR.

I MUST ask you, in justice to Mr. Cowan and myself, to allow space for the article to which reference is made by "A Hallamshire Bee-keeper" on the above subject in your issue of October 27th, and which I venture to think will sufficiently answer the charges brought forward.

The contribution was made under the head of "Useful Hints," in the *British Bee Journal* of July 21st, 1887, by myself, and of it Mr. Cowan was not even cognisant.

The entire responsibility, therefore, rests upon me, and I flatter myself that public opinion will acquit me of any desire to infringe upon what your correspondent claims as his own discovery.

At all events, with him I have no desire to enter into controversy, and beg respectfully to decline being drawn into any discussion beyond the present contribution.—THE WRITER OF "USEFUL HINTS" IN THE *British Bee Journal*, November 2nd, 1887.

"BACILLUS MINOR.—We notice in several American communications, also in our contemporary, the *Record* (current number), descriptions of diseased brood, which differs considerably in its symptoms from the ordinary foul brood. (Bacillus alvei). Of this disease we have had cognisance for some years, but always felt inclined to consider it incipient foul brood, which, if allowed to remain undisturbed, would end in the malignant Bacillus alvei. The symptoms are—listlessness in the bees, while other colonies are energetically at work; death of the larvæ at all ages, but chiefly in its early stages; putridity, free from the usual offensive smell of foul brood; death of the nymphs, unable to emerge from the cells, but free from putrescence, and pierced and sunken cells. Of the few young bees which emerge most are imperfectly developed, some being wingless, others having one wing only, some minus a leg, and many extremely diminutive—the prettiest little dwarfs, indeed, that can well be imagined. Gradually the colony dwindles, although, when possessing a prolific queen, the population is often maintained at par for many months—even to the end of the second year after the commencement of the attack.

"On opening a diseased hive there is no offensive smell perceptible, but still there is an absence of the pure fragrance emanating from a healthy colony during the storing season—a certain acidity which betokens fermentation. With the Editor of the *Record*, we are inclined to the opinion that the disease is partly congenital, but not entirely so, since we have known cases in which the contagion has been conveyed from hive to hive, and in which a change of queens has resulted in the infection of the newly introduced and healthy queen. We have been in the habit of designating this disease by the title of Bacillus minor, although its deadly effect, though slower, is equally sure with that of 'Bacillus major alvei.' That its cause is a species of Bacillus we have not the least doubt, and we hope to be able to induce Mr. Cheshire fully to experiment upon some diseased colonies, and to report the results. Some of the queens lose their pubescence, and become feeble and languid, and whenever, in such cases, an attempt has been made by the bees to supersede the queen, it has invariably failed, the embryo insect

perishing either in the larval or pupa stage. Much of the dead larvæ in the early stage becomes desiccated, and is extruded by the bees, and may often be found on the alighting-board, while beneath may be seen, often in considerable number, the abortive nymphs. Our attempts at curative measures have always failed, although we have applied phenol, salicylic acid (both in syrup and as disinfectants), camphor, coffee, &c. Queens of other infected colonies have, to all appearance, continued in a perfectly normal condition, retaining their pubescence and fertility to the very last. We trust a remedy may soon be found for this insidious and most dangerous disease."

#### TRADE CATALOGUES RECEIVED.

Thomas S. Ware, Hale Farm Nurseries, Tottenham.—*Catalogue of Roses and Shrubs, and List of Specialties.*

James Yates, Underbank, Stockport.—*Catalogue of Carnations and Picotees.*

Ewing & Co., Havant.—*Price List of Nursery Stock.*

B. R. Cant, Colchester.—*Descriptive Rose Catalogue.*

W. Ethington, Swanscombe, Kent.—*Select List of Chrysanthemums.*

Cooling & Sons, Bath.—*Catalogue of Roses and Fruit Trees.*

Little & Balantyne, Carlisle.—*Catalogue of Trees and Shrubs.*

T. S. Ware, Tottenham.—*Catalogues of Roses, Climbing Plants, Peonies, and Specialties.*



\* All correspondence should be directed either to "THE EDITOR" or to "THE PUBLISHER." Letters addressed to Dr. Hogg or members of the staff often remain unopened unavoidably. We request that no one will write privately to any of our correspondents, as doing so subjects them to unjustifiable trouble and expense.

Correspondents should not mix up on the same sheet questions relating to Gardening and those on Bee subjects, and should never send more than two or three questions at once. All articles intended for insertion should be written on one side of the paper only. We cannot reply to questions through the post, and we do not undertake to return rejected communications.

**Book (Young Beginner).**—"Select Ferns and Lycopods," by Mr. B. S. Williams, obtainable at the Victoria and Paradise Nursery, Upper Holloway, will probably suit you.

**Tennis Lawn (J. L.).**—It is not absolutely necessary under all circumstances in forming a lawn tennis ground to put a layer of chalk or other drainage underneath before laying down the turf.

**Bramley's Seedling Apple (A Lincolnshire Gardener).**—No matter how good your "authority" is on the subject, we venture to say that the variety mentioned is quite different from Warner's King. The fruit is different in appearance and solidity, keeping much better than the other, and the tree is a more sturdy grower, yet is abundantly vigorous to form a fine standard.

**Gros Maroc Grape (Gervase).**—No doubt, as you say, the evidence is conflicting relative to the keeping properties of this fine-looking Grape. A good deal depends on houses and management in preserving Grapes sound. We have seen Black Hamburgs in February, but not often, and on the evidence of those few we cannot regard the variety as a long keeper. As you "require sound Grapes of good quality in March, and cannot afford space for experiment," you will adopt a safe course in not relying on Gros Maroc.

**Chionodoxa Lucillæ (S. Porteus).**—This beautiful spring flowering bulbous plant is quite distinct from Scilla bifida, though it is not uncommon to find a few of the latter amongst the Chionodoxas. The bulbs are very similar, and as they are said to grow together where the former are collected it is not easy to separate them, though all firms of standing make every endeavour to do so. If the whole of what you ordered for the Glory of the Snow proved to be Squills we should try some bulbs from another source. Chionodoxas are well worth cultivating, and are as hardy as and often flower with Snowdrops, the combination being appropriate and attractive.

**Improving Lawn (E. Lucas).**—It would be of little use sowing grass seeds now with the object of giving your lawn a "better and greener face," but if you had done so a month or six weeks ago it would in all probability had a greener appearance in winter. Many lawns have been injured by the protracted heat and drought of summer, especially where the soil was thin and poor, and a top-dressing of sifted soil, wood ashes, and manure, with a little bonemeal added thereto, and used as a top-dressing in February, sowing towards the end of March a renovating mixture of lawn seeds would improve them considerably. When lawns consist largely of deep-rooted weeds, such as Plantains, it is the best plan to dig them up, forking the weeds out carefully, add fresh soil, or otherwise enrich the ground, then sow seeds for forming an entirely new lawn. Dry weather in early spring should be chosen for doing the work in question.

**Pears not Bearing (E. Donald).**—It is quite impossible for us to advise you on the question of root-pruning, as you give not the faintest idea as to

whether the trees are stunted in growth, or whether they grow luxuriantly. If the latter is the case, and few or no blossoms expand, then root-pruning, carefully done, would probably be beneficial; but if, on the other hand, they grow little and blossom much, any restriction of the roots would do more harm than good. Severe frosts and inclement weather in spring may have prevented the setting of the fruit. This is often the case, and when the calamity occurs two or three years consecutively the trees not infrequently assume a too luxuriant habit of growth.

**Striking Chrysanthemum Cuttings (J. Simpson).**—It is quite true that "Chrysanthemum cuttings are inserted in November, rooted in cold frames, and there kept all the winter." We do not see why you should wonder at that, as the plants are hardy, though when in frames the pots are plunged to their rims in ashes or cocoa-nut fibre refuse, and the cuttings or young plants are afforded protection from severe frost with mats, straw, or other suitable material. The cuttings are usually, but not always, inserted separately in 2-inch pots, then there is no material disturbance of the roots in repotting. As to the best methods of procedure, that is a question of convenience for raising plants. We prefer them raised under cool conditions in autumn than drawn up weakly in a hot Cucumber frame in the spring. Read Mr. Molyneux's book.

**Sea Eagle Peach (G. D., Hants).**—We have seen excellent crops of this good Peach ripen perfectly on open walls this year in the south of England, and we have not a doubt that it would succeed under good management in Hampshire. It is described as follows in the "Fruit Manual," and you will perceive it is there stated to be suitable for your purpose:—"Fruit very large, 3½ inches wide and 3 inches high, round and even in its outline, and marked with a slight suture. Skin pale lemon yellow, and with a deep red cheek on the side next the sun, that on the shaded side being paler. Flesh white, with a pale yellow tinge and a deep stain of red next the stone, which extends nearly through the whole; vinous and richly flavoured. Flowers large. Leaves with round glands. A very handsome late Peach, ripening in the end of September and beginning of October in the open air, and one of the best for outdoor cultivation. It was raised by Mr. Rivers of Sawbridgeworth from Early Silver Peach."

**Plants for Shaded Wall (R. D. K.).**—We question if there is any plant better adapted for "covering a wall much shaded by Palms and Ferns in a large and warm conservatory," than *Ficus repens minima*. It clings to the wall like Ivy, forming a smooth face of deep green leaves, not much larger than those of the tree Box, but much darker and more pointed. The warmer the house the faster it grows, and it likes moisture in the summer. The lofty back walls of a range of houses at East Cliff, Lincoln, are beautifully covered with this *Ficus*, and much admired by visitors. The species, *Ficus repens*, has larger leaves, and may perhaps cover a wall a little more quickly than its smaller variety, but of this we are not sure. Possibly if this meets the eye of Mr. Wipf, Mr. Clayton's able gardener, at Lincoln, he may oblige by stating how long the plants were in covering the wall so effectively. The climbing Fern, *Lygodium scandens*, would cover the wall attractively in summer if wires were provided up which it could climb, but it loses many of its fronds in winter, especially in cool houses. *Asparagus plumosus nanus* grows well in the shade, and soon covers a lofty wall, where a warm greenhouse or cool stove temperature is maintained, and has a very agreeable appearance.

**Tuberose Culture (W. P. R.).**—A successful grower has described his method of culture as follows:—"The imported bulbs are received in December or January, when they are at once potted singly in 6-inch pots, and plunged where they can have the benefit of bottom heat to start them into growth. After they once start fairly they can be grown in a lower temperature and without bottom heat; and when all danger of frost is over, if they are not wanted to flower early, they can be placed in a deep cold pit and be merely protected from the worst of the weather till the flowers commence opening, when they will be improved by being taken into the greenhouse. Plants so treated will generally flower some time between July and October. After flowering most people throw them away as useless. This is quite a mistake, as I will endeavour to prove. Mine are at once shifted into 7 or 8 inch pots without disturbing the ball, using a good rich compost consisting of turfy loam with a little decayed manure, a few half-inch bones, and a little charcoal. They are again placed in a warm house and soon commence throwing up shoots out of which only 1 is left to grow, and it soon forms a new bulb on the top of the old one, which will not fail in its turn to send up a good strong flower stem. The American variety known as The Pearl is one of the best, and is largely grown by those engaged in supplying cut flowers for Covent Garden Market."

**Names of Fruits.**—The names and addresses of senders of fruit to be named must in all cases be enclosed with the specimens, whether letters referring to the fruit are sent by post or not. The names are not necessarily required for publication, initials sufficing for that. Only six specimens can be named at once, and any beyond that number cannot be preserved. (G. B. Henley).—1, Thompson's; 2, Deux Sœurs; 3, Easter Beurré; 4, Uvedal's St. Germain; 5, Maréchal de Cour; 6, Chaumontel (John Cranston & Co.).—4, Passe Colmar; 5, Fondante de Malin's; 6, Orange Bergamot; 7, Napoëon; 9, Beurré Rance; 10, Chaumontel. (H. Hewat Crow).—1, Kerry Pippin. This is surely the Apple which puzzled us so much last year. It seems to keep so long when grown on your soil that we failed to recognise it. 2, Is very much like Cackle's Pippin, but too angular at the upper part, which may be the result of local influences. 3, Not Graven-tin, probably Wormsley Pippin; 4, Afriston; 5, Afriston. (Quota).—Pears—1, Nouveau Poiteau; 2, Pitmaston Duchesse; 3, Maréchal de Cour; Apples—2, Beauty of Kent; 3, Wormsley Gange. (P. H. Wright).—Marie Louise.

**Names of Plants.**—We only undertake to name species of plants, not varieties that have originated from seed and termed florists' flowers. Flowering specimens are necessary of flowering plants, and Fern fronds should bear spores. Specimens should arrive in a fresh state in firm boxes. Slightly damp moss or soft green leaves form the best packing, dry cotton wool the worst. Not more than six specimens can be named at once. (M. C. B.).—No numbers were attached to the specimens, it is therefore difficult to make it clear to which the names apply. The purple flower is *Aster novæ-angliæ*; the plant with small blue flowers in close spikes is

*Veronica spicata*; the slender plant without flowers we cannot name, but it resembles a *Coleonema* in growth; the yellow flower was quite withered. (E. R. W.).—The specimen was scarcely recognisable, but is thought to be *Epidendrum replicatum*.

COVENT GARDEN MARKET.—NOVEMBER 9TH.

BUSINESS in an unsettled state. Prices unaltered.

PLANTS IN POTS.			
	s.	d.	s. d.
Aralia Sieboldi, dozen	6	0	to 12 0
Arbor vitæ (golden) dozen	6	0	9 0
" (common), dozen	0	0	0 0
Asters, dozen pots	0	0	0 0
Azalea, dozen	0	0	0 0
Begonias, dozen	4	0	9 0
Capsicums, dozen	0	0	0 0
Chrysanthemums, dozen	4	0	12 0
Cineraria, dozen	0	0	0 0
Dracæna terminalis, doz.	30	0	60 0
" viridis, dozen	12	0	24 0
Erica, various, dozen	9	0	18 0
Euonymus, in var., dozen	6	0	18 0
Evergreens, in var., dozen	6	0	24 0
Ferns, in variety, dozen	4	0	18 0
Ficus elastica, each	1	6	7 0
Foliage Plants, var., each	2	0	10 0
Fuchsia, dozen	6	0	to 9 0
Geranium (Ivy), dozen	0	0	0 0
" Tricolor, dozen	0	0	0 0
Glaucolus	0	0	0 0
Hydrangea, dozen	9	0	12 0
Lilies Valley, dozen	0	0	0 0
Lilium lancifolium, doz.	0	0	0 0
" longiflorum, doz.	0	0	0 0
Lobelia, dozen	0	0	0 0
Marguerite Daisy, dozen	6	0	12 0
Mignonette, dozen	3	0	6 0
Musk, dozen	0	0	0 0
Myrtles, dozen	6	0	12 0
Palms, in var., each	2	6	21 0
Pelargoniums, dozen	0	0	0 0
" scarlet, doz.	3	0	9 0
Spiræa, dozen	0	0	0 0

CUT FLOWERS.			
	s.	d.	s. d.
Ahulfions, 12 bunches	3	0	to 6 0
Anemones, 12 bunches	0	0	0 0
Arum Lilies, 12 blooms	6	0	9 0
Asters, 12 bunches	2	0	6 0
" French, bunch	0	0	0 0
Bouvardias, bunch	0	6	1 0
Camellias, blooms	3	0	6 0
Carnations, 12 blooms	1	0	2 0
" 12 bunches	0	0	0 0
Chrysanthemums, 12 bchs.	6	0	12 0
" 12 blooms	1	6	6 0
Cornflower, 12 bunches	0	0	0 0
Dahlia, 12 bunches	0	0	0 0
Daisies, 12 bunches	2	0	4 0
Eucbaris, dozen	6	0	8 0
Gardenias, 12 blooms	2	0	5 0
Glaucolus, 12 sprays	1	0	1 6
Hyacinths, Roman, 12 sprays	1	6	2 6
Iris, 12 bunches	0	0	0 0
Lapageria, white, 12 blooms	1	6	3 0
Lapageria, coloured, 12 blooms	1	0	1 6
Lilium longiflorum, 12 blooms	6	0	9 0
Lilium lancifolium, 12 blooms	1	6	3 0
Lilies, White, 12 bunches	0	0	to 0 0
" Orange, 12 bunches	0	0	0 0
Marguerites, 12 bunches	2	0	6 0
Mignonette, 12 bunches	1	0	3 0
Myosotis, 12 bunches	0	0	0 0
Narcis, 12 bunches	0	0	0 0
" White, English, bch.	0	0	0 0
Pansies, 12 bunches	0	0	0 0
Peas, Sweet, 12 bunches	0	0	0 0
Pelargoniums, 12 trusses	0	9	1 0
" scarlet, 12 trusses	0	4	0 9
Poinsettia, 12 blooms	0	0	0 0
Primula (single), bunch	0	0	0 0
" (double), bunch	0	9	1 0
Polyanthus, 12 bunches	0	0	0 0
Ranunculus, 12 bunches	0	0	0 0
Roses, 12 bunches	0	0	0 0
" (indoor), dozen	1	0	1 6
" Tea, dozen	1	6	3 0
" red, dozen (French)	1	0	2 0
" yellow	0	9	1 6
Stephanotis, 12 sprays	4	0	6 0
Tropeolum, 12 bunches	0	0	0 0
Tuberoses, 12 blooms	0	6	1 0
Tulips, dozen blooms	0	0	0 0
Violets, 12 bunches	1	0	1 6
" (French), bunch	1	6	2 0
" (Parme), bunch	5	0	6 0

FRUIT.			
	s.	d.	s. d.
Apples, ½ sieve	1	6	to 3 6
Nova Scotia and Canada barrel	0	0	0 0
Cherries, ½ sieve	0	0	0 0
Cobs, 100 lbs.	65	0	50 0
Figs, dozen	0	0	0 0
Grapes, per lb.	0	6	2 6
Lemons, case	10	0	15 0
Melon, each	0	6	1 0
Oranges, per 100	6	0	to 12 0
Peaches, dozen	2	0	6 0
Pears, dozen	1	0	1 6
Pine Apples, English, per lb.	1	6	2 6
Plums, ½ sieve	0	0	0 0
St. Michael Pines, each	3	0	5 0
Strawberries, per lb.	0	0	0 0

VEGETABLES.			
	s.	d.	s. d.
Artichokes, dozen	1	0	to 2 0
Asparagus, bundle	0	0	0 0
Beans, Kidney, per lb.	0	3	0 0
Beet, Red, dozen	1	0	2 0
Broccoli, bundle	0	0	0 0
Brussels Sprout, ½ sieve	3	6	4 0
Cabbage, dozen	1	6	0 0
Capsicums, per 100	1	6	2 0
Carrots, bunch	0	4	0 0
Cauliflowers, dozen	3	0	4 0
Celery, bundle	1	6	2 0
Coleworts, doz. bunches	2	0	4 0
Cucumbers, each	0	4	0 6
Endive, dozen	1	0	2 0
Herbs, bunch	0	2	0 0
Leeks, bunch	0	3	0 4
Lettuce, dozen	0	9	to 0 0
Mushrooms, punnet	0	6	1 0
Mustard and Cress, punnet	0	2	0 6
Onions, bunch	0	3	0 6
Parsley, dozen bunches	2	0	3 0
Parsnips, dozen	1	0	0 0
Potatoes, per cwt.	4	0	5 0
" Kidney, per cwt.	4	0	0 0
Rhubarb, bundle	0	2	0 0
Salsafy, bundle	1	0	1 6
Scorzoneria, bundle	1	6	0 0
Seakale, basket	0	0	0 0
Sballots, per lb.	0	3	0 0
Spinach, bushel	1	6	2 0
Tomatoes, per lb.	0	4	0 6
Turnips, bunch	0	4	0 6



PROGRESS.

IMPROVEMENTS in the general management of farms near large towns are much in advance of the general practice still followed in those which are distant from a town or railway station. This state of things is just an outcome of circumstances, yet we hold that the distance is much greater than it ought to be. Let us take for

example the formula laid down for the guidance of the judges in the annual farm-prize competition under the auspices of the Royal Agricultural Society of England, which are:—

- 1, General management with a view to profit.
- 2, Productiveness of crops.
- 3, Quality and suitability of live stock
- 4, Management of grass land.
- 5, State of gates, fences, roads, and general neatness.
- 6, Mode of book-keeping followed (if any).
- 7, Management of the dairy and dairy produce, if dairying is pursued.

And we think it must be granted that the conditions so specified are of importance upon any farm, especially the first of them. For it is undoubtedly the general management with a view to profit that marks the progress or the reverse in a farmer's practice.

The cropping of a first-prize farm near Liverpool on the estate of the Earl of Derby was 34 acres Wheat (19 acres after a layer, 15 acres after Potatoes and Turnips), 17 acres of Oats (5 after roots, and 12 after a layer), 15 acres of Barley, 5 acres of Tares, 22 acres of Potatoes, 2 acres of Swedes, 1 acre of Mangolds, 42 acres of first year's seeds (22 after Oats and 14 after Wheat), 22 acres of second year's seeds, 6 acres of permanent pasture. No strict rotation is followed, but it is usually as follows:—First year, fallow crop, mostly Potatoes, and a few Swedes and Mangolds. Second year, Wheat sown down with seeds. Third and fourth year, grass, usually cut five times in the two years. Fifth year, Oats, and sometimes Wheat.

Now, we have drawn attention to a similar rotation to this before, but we give the course and cropping here fully, as showing the sort of crops which are found to answer best near a large town. It will be noticed that a large proportion of the land is in seeds—that is to say, a mixture of the stronger-growing Grasses and Clovers, of which extraordinary crops are had by the repeated application of top-dressings of sawdust soaked previously in liquid manure. We commend this dressing to the attention of buyers of peat moss litter for the bedding of horses. We tried the peat moss litter upon its first introduction into this country, and are bound to own that we found it answer well enough, but we ask, Why buy it when we have a much cheaper and equally suitable supply of such material as sawdust ready to our hands? Sawdust is now much used in towns as bedding for horses, and it is eagerly sought after by farmers, who find a ready sale in return of green fodder, of which heavy successional crops are obtained by liberal top-dressings of the saturated sawdust

To show something more of practical details on such a farm we may add that in the year it was in competition for the prize 160 tons of hay were made there; that the first crop of grass was 12 tons an acre, which sold at 20s. a ton; of Tares the yield was 16 tons an acre at rather under 20s., a ton, and there was something like 110 tons to dispose of. But, then, it must be mentioned that some 1500 tons of manure was used either as top-dressing or for ploughing in, and clearly the result justified the expenditure.

Repeatedly are cleanliness and thorough cultivation mentioned in the account given of the farm by the judges; and we take it as a remarkable example of what may be done by an intelligent farmer keeping well within the scope of his means, and doing his work in the best possible manner. We recently gave an account of the practice

upon the farm of the Aylesbury Dairy Farm near Horscham, in which the condition of the land was said to approach that of a garden owing to superior and very deep cultivation. Why should it not be so? we ask. If by high cultivation we ensure crops proportionate in bulk and quality to our work in the production of them, then by all means let us have them. Repeatedly have we urged the importance of such high farming upon the notice of our readers, and we doubt not that eventually, instead of the best land going out of cultivation, we shall find it is being brought into a state of fertility such as our forefathers never conceived possible. That indeed will be a sign of progress much to be desired, for then shall we be able to hold our own in the keen competition with produce imported from the markets of the world, which competition we fear it is a foregone conclusion that we cannot avoid, and are therefore bound to grapple with it in the best way we can.

(To be continued).

#### WORK ON THE HOME FARM.

The labour question has become a serious matter to farmers as well as labourers, for the farmer is bound to curtail expenditure in everything, and payments for labour are reduced as low as possible. Instead of hedging, ditching, and draining being done in winter, little if any of such work is done now. Ploughing is pushed briskly on after harvest, winter corn sown, the root crop got off the land entirely or in part, and then the men who are regarded as supernumeraries are turned off to shift for themselves. Greatly as we deplore this unsatisfactory arrangement, yet it is by no means an easy matter to suggest a remedy. But we do say that under no circumstances can it answer for land to be badly cultivated, and it is clearly wiser for a farmer to curtail his acres rather than his labour, to do all the work he can by the use of improved farm implements, to select a few intelligent men, and so arrange his farm work as to keep on the men constantly. Harvest work and corn thrashing of course call for extra labour, which need not be dwelt upon now, as such labour is always forthcoming.

We have frequent consignments of small pigs of the size termed Londoners sent to the Metropolitan Meat Market, and generally find it answer best to have them killed and so disposed of rather than send them alive to local sales. Careful selection is, however, necessary for the London market, the best size being from 6 to 7 stones of 8 lbs. In proof of this, we may mention that of our last consignment, porkers weighing 7 stone sold readily for 4s. 4d. per stone, but others weighing 10 stone only realised 3s. 10d. per stone. The salesman said the 10 stone pigs were altogether too large and fat, the smaller size, not fat, being most in demand. This is one of those matters of detail worthy of attention, as leading to a profit upon both the feeding and sale of pigs. The smaller size of porkers should be had at the age of eight or nine weeks, but to have them ready for market by that age they must have the benefit of careful attention in feeding, warmth, and cleanliness, and there is no question that such care answers. We recently saw a sty containing a lot of porkers withdrawn from the sow and in a state of semi-starvation. Two or three Mangolds had been thrown to them, but no sign was there of corn eating, and they would require much of it to bring them into condition.

#### METEOROLOGICAL OBSERVATIONS.

CAMDEN SQUARE, LONDON.

Lat. 51° 32' 40" N.; Long. 0° 8' 0" W.; Altitude, 111 feet.

DATE.	9 A.M.				IN THE DAY.				Rain			
	Baromet. ter at 33 and Sea Level.	Hygrome- ter.		Direction of Wind.	Temp. of soil at 1 foot.	Shade Tem- perature.		Radiation Temperature				
		Dry.	Wet.			Max.	Min.	In sun.		On grass		
1887.		deg.	deg.		deg.	deg.	deg.	deg.	deg.	Ir.		
Oct. & Nov.	Inches.	deg.	deg.		deg.	deg.	deg.	deg.	deg.	Ir.		
Sunday .....	31	29.345	42.8	42.2	W.	45.0	52.3	38.9	86.7	59.0	0.61	
Monday .....	31	29.533	40.0	38.4	W.	44.8	50.4	37.9	81.5	3.5	—	
Tuesday .....	1	29.329	47.4	43.4	S.	44.0	48.4	38.1	52.2	3.4	0.276	
Wednesday .....	2	29.246	45.9	44.0	S.	43.9	52.1	39.2	81.2	31.3	0.163	
Thursday .....	3	28.839	49.5	44.1	S.	44.2	51.6	43.2	79.2	26.7	0.604	
Friday .....	4	28.980	48.4	45.5	S.W.	44.8	55.4	42.3	82.9	39.4	0.163	
Saturday .....	5	29.537	40.6	40.0	W.	44.8	53.0	37.4	89.9	32.6	0.212	
		29.238	44.9	43.1			44.5	51.9	39.6	79.1	34.3	2.035

#### REMARKS.

- 30th.—Gale in small hours; violent squall at about 5.30 a.m.; day generally bright, but with occasional showers and rainbows; lunar halo in the evening.
  - 31st.—Fine and bright after 11 a.m.; clear night.
  - 1st.—Unusually red sunrise; squally from S.E., with rain from 10 a.m. till 4 p.m., then dull and damp.
  - 2nd.—Morning alternately bright and dull, with rain at 7.30, between 9 and 10, and a few spots at 11.40 a.m.; fine bright afternoon; windy night.
  - 3rd.—Wet morning, with very low barometric pressure; bright for a couple of hours at midday; then chill again with frequent rain.
  - 4th.—Fine bright morning, with showers in the afternoon.
  - 5th.—Fine and generally bright; rain in late evening and night.
- A stormy and very wet week. Temperature about 3° above that of the preceding week, and 1° below the average.—G. J. SYMONS.





## COMING EVENTS

17	TH	Colchester, Chiswick, Hull, Barnsley, Taunton, Bolton, and Wimbledon	
18	F	Sheffield and West Riding, Reading, and Chorley Shows.	[Shows.]
19	S	Ramsbottom Show.	
20	SUN	24TH SUNDAY AFTER TRINITY.	
21	M	Wolverhampton Show.	
22	TU		[Westminster.]
23	W	Bedford Show. National Chrysanthemum Society—Floral Committee,	

### WINNING AND LOSING PRIZES.

**N**T no period of the year is greater interest manifested in the floral world than during the present month, when the prizes offered for Chrysanthemums are being keenly contested for. Many of these have been lost and won now, yet many more remain to be decided. It is curious to observe how showing—that is, winning and losing prizes—brings out the idiosyncracies of individuals; and as a rule it is noticeable that those who are the most jubilant when winning the honours provided are, obversely, the most depressed, not to say annoyed, when they happen to lose them. Occasionally we find an unsuccessful exhibitor so overcome by a defeat that he cannot restrain himself, and the only relief he appears to find consists in abusing the judges, who in his view have committed the glaring mistake of inspecting the exhibits with their own eyes instead of his. It is reported that when Canon Hole had once been adjudicating at a Rose show, a disappointed exhibitor was so violent in the denunciation of the awards that the Canon was moved to rebuke him in this gentle but not to be forgotten manner—"My friend, I always said if ever I went crazed it would be over the Rose." It was very sympathetic, no doubt, but very keen, and it is said the man of noise collapsed.

After some experience of shows and showing I have found that no competitor is so unpopular, even with persons whom he regards as his friends, as one who gains for himself the notoriety of being a "bad loser;" and, on the other hand, no one wins such general respect as an exhibitor who accepts his defeat manfully, or who at least does not impute sinister motives to the adjudicators nor proclaim the incapacity of officials of at least equal, and probably of far greater, experience than himself.

It would perhaps be difficult to mention a better loser at floral contests than the late Mr. Charles Turner of Slough. Even if he should think the adjudicators had made a slight mistake, which is a possible occurrence, he took care not to make another mistake by a torrent of verbal abuse in the show, or writing ill-judged letters to the press assertive of his own superiority, not as a cultivator alone, but as a judge of his own handiwork. An exhibitor who does such things may be a good judge and honest in his convictions, but he cannot make the public believe in his strict impartiality. That is not the way to get mistakes rectified; and if by accident they occur, no judges worthy of the name, and no directors of a show, would hesitate to put right what was alleged to be wrong if their attention were called to the matter in a reasonable manner; and if after a searching re-examination of the products in competition no reason is found for alter-

ing the awards the disappointed contestant, who still storms, simply makes himself obnoxious and does injury to a society, because cultivators have no pleasure in entering the lists against him. Mr. Turner, when he happened to sustain a defeat, used to pass it off with a pleasant shrug of his shoulders and a well-known observation—"Ah, well! we must try again, and do better another time." That is a spirit which all admire—a manly utterance implying conscious strength, and a persevering nature that never fails in the end, not in winning prizes only, but the wide and unfeigned respect of all who are connected with shows and showing.

It is fortunate there are so many exhibitors in the Chrysanthemum ranks who, though hard-working gardeners, yet are true gentlemen in putting the best construction on decisions that may happen to be adverse to their own interests, and not attributing motives that are the reverse of honourable to persons who can have no other motive than to do what is right in each case, and who, if they should happen to err through whatever cause, would be the first to hasten to rectify the error if it were brought to their notice in time for them to do so. They would do this in the maintenance of their own reputation—as an act of justice, so to say, to themselves as well as to others; and only the thoughtless, prejudiced, or those capable of swerving from the path of duty could refuse to admit that such is the fact. The few who are differently constituted render themselves by their scarcity the more conspicuous, and are pitied accordingly. The man who cannot lose a prize without losing his temper is out of place as an exhibitor, and will best consult his own peace of mind and the comfort of others by winning fame at home, as he may be quite capable of doing, and as many have done in the past and as others will do in the future.

Exhibiting is made pleasant or the reverse by the conduct of those who engage in it, and beyond any doubt those who receive their honours without ostentation, and bear their losses bravely, command the most esteem. No better evidence of this is necessary than that afforded by an episode at the National Chrysanthemum Show last year, when Mr. C. Gibson, by an accident of his own, placed himself out of competition in a class in which he was the best exhibitor. His manly bearing on that, as on all occasions whether he wins or loses, led to the performance of an act as graceful as it was gratifying—the granting of a silver cup to him, which must surely be one of his most prized possessions. Had he been one of the unenviable few who rejoice in the defeat of others and rebel against their own, his discomfiture would have been regarded as befitting, and certainly no substantial token of sympathy would have been forthcoming under the circumstances. The judges who disqualified him did their duty, and he knew it, hence acquiesced in the decision. He has more recently won the great prize at Kingston, and is thus rewarded for his perseverance through several contests. However near he was previously to the goal, not a murmur escaped him, and it was his high-minded conduct in this respect—retiring with grace and a resolve to try again, that caused such an unanimity of congratulations to be expressed on his well won triumph.

Nothing is more pleasant in a show and more agreeable to all connected therewith than to see a loser bearing his defeat bravely. In this is displayed the character of the man, and it commands general approval. On the other hand nothing is more painful and pitiful in con-

nection with exhibitions than to see and hear a disappointed competitor indulge in the vulgar exercise of abusing the judges, and proclaiming their incapacity, if not something worse, in respect to classes in which the verdict has been against him, while he approves that of the same officials when in other classes they award him the coveted prize. He thus places himself in a dilemma of admitting their competence and fairness, while he at the same time condemns it. It is a most unenviable, not to say humiliating, position to be placed in, and only wants to be seen and recorded to be avoided. It is further curious that anyone so forgetting himself should be blind to the results, these being almost inevitably to strengthen the judges and weaken himself.

In awarding the prizes for Chrysanthemums and other products, the judges do not know, nor want to know, whose collections are under examination, and that fact alone ought to shield them from the repulsive charge of favouritism; yet such insinuations are not unknown, and it is because there are exhibitors capable of entertaining them that encouragement is withheld by those who are able to grant it effectually, and public exhibitions lose the support they would otherwise obtain, and thus a serious check is given to the advancement of practical horticulture. It does not follow, however, that judges of garden produce should be above criticism. They are public functionaries, and as such are, by their decisions, open to public criticism. If they are incapable, the committees of shows and societies are responsible for their appointment. If open to influence from whatever source they must thereby merit the contempt of honourable men, and ought to be drummed out of the ranks of the great army of cultivators to which they belong. Judges must be men of ability, integrity, and courage; and exhibitors men of mettle who can accept defeat when it is their lot to endure it, because the time is never likely to arrive when they will be tolerated to judge their own products and award themselves prizes to which they have no just claim.—EXPERIENTIA DOCET.

### SOME GOOD HARDY PLANTS AND THE WAY TO INCREASE THEM.

ALL real lovers of their gardens, and those who wish for something more useful than the class of plants with which the beds and borders are at present filled from year to year, welcome the growing taste for hardy plants, and the change which is gradually taking place of a more natural arrangement. The want at present felt by a great many gardeners and amateurs is a better knowledge of the best and quickest means of propagating and raising a good stock of the various things that are recommended to be grown. There is no comparison between the beauty of our hardy plants when grown in masses and the same plants in two or three isolated specimens. Beds and borders filled with a few good things are far more useful for cutting from, and more effective than if filled with a mixture of many kinds. Before they can be used in this manner a good supply of plants at command is requisite. To buy them in any quantity soon becomes expensive, but many of the best plants are easy of propagation, and the grower will soon become acquainted with the best means of doing so, by observing the habits of the different classes of plants. Some are easily increased by dividing the roots, others by seed and cuttings. Raising them from seed is always interesting, and a good batch of something uncommon can often be obtained in this manner.

A sharp look-out should always be kept for any plants which show signs of ripening seed, and be careful dying stems are not cut off indiscriminately by those tidying the borders, and the chance of saving it be lost. The first flowers which open should be left on plants of which seed is desired, as these have a better chance of ripening, and will always be found to contain a greater proportion of good seeds. The pods or heads should be gathered before they become quite ripe, or they will burst and the seeds be lost; others will be blown away by the wind.

Most seeds are best sown as soon as ripe, if not too late in the season (say the end of August), then it is better to defer sowing until spring. Some seeds are a long while germinating, and are often thrown away, after a time, under the impression they were bad. For this reason it is best to keep seeds of hardy perennials by themselves. A small frame and a few handlights will do for this purpose. In summer time a rather cool shady place is most suitable for them until germination takes place, when more air and light should be given to prevent the seedlings becoming drawn.

Cuttings, both of roots and tops, are ready means of increasing many hardy plants. Most of them will strike in a cold frame or under handlights. The point most particularly to be observed is to insert the cuttings and place them where they are to strike as soon as possible after they are taken off, and keep them close until rooting commences. A border should be set apart as a nursery where seedlings, rooted cuttings, and offsets can be planted out for a time until they are large enough to be transplanted to their permanent quarters. The following are some effective and useful plants illustrating different modes of propagation. Japanese Anemones, white and pink, are amongst the first on the list. In March lift the soil round the old plants with a fork, when numerous buds will be found just ready to burst into leaf. These should be taken off with an inch or so of root attached, and inserted in pans of light soil. Place them in a frame (if with a gentle bottom heat the better). When two or three leaves have grown to each cutting harden them off, and plant out in rows on the nursery border. By autumn they will have grown into good plants for filling beds or forming groups in the borders.

Narcissus are all beautiful and desirable. The incomparabilis and poeticus sections are perhaps the most hardy and useful. Their long flower stalks and light elegant blooms make them most valuable flowers for cutting. To increase them, lift the old clumps when the foliage has turned yellow, divide them, take off the offsets. The largest bulbs can be planted in the same place, if desirable, after replacing the old soil with some new. The small bulbs and offsets plant out in rows on the nursery border. In two or three years they will grow into flowering bulbs.

German Irises are increased by dividing the roots either in spring or autumn. The offset should have two seasons in the nursery border, when they will be strong clumps for transplanting. When making groups of them do not plant too closely, leave spaces between to be planted with *Gladiolus*. These flowering after the Irises take off the bareness they have in summer when by themselves.

Perennial Sunflowers should be largely planted. The varieties which are too tall for the flower garden can be used in the shrubberies. Dividing the roots in spring is the usual way of increasing them, but if one has only a few plants it takes some time to get a good stock in this manner. The small shoots which spring from the axils of the leaves on the flower stems may be taken off with a heel, or the stems, before becoming too hard, can be cut into lengths with a pair of leaves at the top. Place them under close handlights. Although they are rather slow in striking, eventually roots will be formed, and they will make good plants. Winter them in a cold frame and plant out in spring. The side shoots on the flower stems of *Lychnis chalconica plena* will strike in the same way.

*Rudbeckia Newmanni*, perhaps next to *Anemone japonica*, is the most popular of hardy perennials, and deservedly so. It is a plant that is easily propagated either by division, cuttings, or seed. The cuttings should be put in about August. *Bupthalmium salicifolium*, *Helenium pumilum*, and *Doronicum Harpur Crewe*, are three most useful yellow Composites. The latter is valuable as it flowers early. They are all propagated in the same way as *Rudbeckia Newmanni*.

Although of the same character and colour, *Coreopsis lanceolata* claims a foremost place on account of its value for cutting purposes, also its long season of flowering. It is best raised from seed annually. Plant the seedlings in the nursery for a time where they will form strong clumps for transplanting.

*Senecio pulcher* should be largely grown on account of its colour. This plant can be increased by cuttings of the roots, which should be taken off in the spring. Cut into lengths of about an inch, and given a little bottom heat, a good stock can soon be raised in this manner. I have found it a rather difficult plant to save seed of, but this year I have saved some.

*Pentstemon barbatus* is not often seen, but when seen in good clumps it is very beautiful with its long elegant spikes of scarlet flowers. The cuttings are a long time forming roots, and require to be kept close under handlights.

*Erigeron speciosus superbus*, when seen in large masses, is a striking object in the garden. The quiet colour of the flowers, which are produced in profusion, is always pleasing to the eye.

They keep fresh a long time in water when cut. Cuttings taken in August soon root under handlights.

The variety of the Tiger Lily named splendens is far superior to the type, the spikes and individual blooms are larger, and the colour brighter. The small bulblets which form in the axils of the leaves on the flower stems should be collected and sown in pans of light soil. When large enough plant them out in the nursery.

*Hyacinthus candicans* is seldom out of place wherever it is planted. It is easily raised from seed. The seedlings will bloom the year after sowing.

I am afraid my list is already too long, but I cannot omit the perennial *Asters*. No garden should be without a good selection of them. *A. Amellus* is the best; *longifolius formosus* is also very good. *Archie Hind* is taller, but very free flowering. It is rather difficult to get them true to name. Before propagating any kind in quantity it is well to make sure you have a good variety. *A. Amellus* is not so readily increased by division as the other kinds, but if seed can be secured of it a good stock can soon be raised for home planting.—A. BARKER, *Hindlip*.

### MULCHING STRAWBERRY PLANTATIONS.

THIS operation is generally performed in the spring, but in my opinion the present time (or rather the first time after this that the frost has sufficiently hardened the ground to render wheeling on it a harmless operation) is the most suitable time, especially for young plantations. Although the Strawberry is comparatively a hardy plant, young plants that have not had sufficient time to get well established in the ground sometimes suffer most severely in very hard winters, especially in low-lying and damp districts, but on higher and drier ground the plants appear to stand the winter better. Apart from the protection the mulching affords to the plants, it can far more conveniently be placed on the ground when slightly frozen, and other work at this time is not so pressing as in the spring. I have for several years mulched Strawberries in early winter, and have seen the good effect it has produced on the plants, and especially during last summer, which proved so dry all through the season. Some may be inclined to say that the stimulating properties of the manure would be all washed out of it before the plants could assimilate it, but I consider where the ground is prepared for planting Strawberries it should be made sufficiently good and solid that the plants should be independent of assistance from the mulching for at least two years after planting. After the second season a mulching of a more stimulating nature may with advantage be applied. When the ground is solid I consider that it retains all the stimulating properties of the manure the rains may wash out of it, and if the manure consists, as it ought to do, of a portion of rather long straw material, that will get well sweetened by the action of the air and rain, and form a good bed for the fruit to lie upon. When the mulching is placed on it should be applied round the plants, so that in the winter time the bed will have the appearance of a bed of straw rather than a Strawberry bed. Some may say that the mulching would form a good harbour for slugs during frosty weather, but if the mulching was not on they would only descend farther into the ground out of the reach of frost. The many advantages that arise from applying it on at this season of the year are sufficient to counterbalance any slight objection that may be brought forward. I am assuming that no disturbance of the soil will take place either before or after the mulching is applied in the shape of forking between the rows. In my practice no implement is used among the plants except the hoe after the fruit and runners are off; the old mulching is cleared off, and the ground lightly hoed to keep down weeds, and when frost comes round again fresh mulching is applied.

Some Strawberries are much more tender than others. *British Queen*, although a strong grower, will sometimes succumb to a hard winter. All those that are found to suffer most should have a thicker coating of mulching material, which may be of a lighter nature. The best manure for the purpose is undoubtedly that from the stables where a good supply of straw is used in bedding. This thrown together just as it comes from the stables, and turned over twice, will make an excellent mulching, protecting them from frost in winter, drought in summer, and enable them to bring to maturity good crops of fruit—that is, if other conditions are favourable.—W. SIMPSON, *Knowsley*.

### ROSES AT ALDERMINSTER LODGE.

THE Rev. J. A. Williams is a well-known rosarian, and in a very pleasant district, not far from Stratford-on-Avon, he grows Roses admirably, Teas especially. Not that the soil is one of the best, but Mr. Williams knows so well what to do with Roses that he

is never without good blooms from June until December unless the latter month should be most wintery. At the foot of his garden a narrow portion of the river Avon is situated, and when tired of using its water he can sit down in the shade and indulge in piscatorial pursuits. Mr. Williams not only excels in Roses, but he is a good all-round amateur gardener, and the cottage gardens about Alderminster give evidence of his practical teachings in this respect. When he gave his lecture on Roses lately in Birmingham he brought with him superb blooms, which were much admired, and induced me to pay him a visit soon afterwards to see his plants and how he treated them. The garden is rather exposed and slopes towards the river, so that Roses do not suffer from an excess of moisture at the roots and ripen the wood well. With good manure underneath and mulchings in summer the Teas luxuriate, and amongst the numerous collection at Alderminster Lodge the following were very fine in October:—

**MADAME LAMBARDE.**—A most profuse bloomer and fine in form, varying in the shades of colour, sometimes darker than at others, and also in the foliage; a very fine variety.

**PERLE DES JARDINS.**—Pale yellow and very free blooming, especially in the autumn; a lovely Rose.

**HOMERE.**—This good old variety does not do well here as a dwarf, and Mr. Williams thinks it should be grown with him as a standard.

**MOIRET.**—Exquisite in a half expanded state, and a very free bloomer.

**INNOCENTE PIROLA.**—White tinted with flesh; a lovely Rose and a good autumnal bloomer.

**ALBA ROSEA.**—Very free blooming, and a favourite with Mr. Williams.

**ANNA OLIVIER.**—Tinted rosy buff, fine.

**SOUVENIR DE PAUL NEYRON.**—White, tinted with rose and yellow.

**CATHERINE MERMET.**—Shy in blooming, but a beautiful Rose.

**GRACE DARLING.**—One of Mr. Bennett's new Roses, light shaded pink, continuous bloomer, and a beautiful Rose.

**MARIE VAN HOUTTE.**—In various stages and fine everywhere; a grand Tea, and should be generally planted. I noticed on a young shoot of a young plant eight good blooms.

**MONSIEUR FURTADO.**—Bright sulphur yellow.

**RUBENS.**—A very early bloomer, white, tinted with rose, free grower and excellent for market work.

**AMAZONE.**—A long pointed bud of the richest yellow colour.

**JEAN DUCHER.**—Very distinct, and, as with Madame Lambard, varies in colour. Mr. Williams designates its colour as "Strawberries and cream," as it resembles that combination in colour: very lovely, but not a wet weather Rose.

**BELLE LYONNAISE.**—There is a monster tree of this variety growing against the stables, which flowers continuously and is most useful.

These are but a few of the fine Roses grown at Alderminster. Of course there are such varieties as William Allen Richardson and Bouquet d'Or, the latter a free grower and a very free bloomer, short-jointed wood, and a fine buttonhole Rose. *Gloire de Dijon* does best here in a northern aspect, as it colours better.

What a grand climbing Rose *Reine Olga de Wurtemberg* is. Mr. Williams has a large tree, which covers a considerable space of wall, and for its rich deep green glossy foliage alone it is worthy of a foremost place. It is a strong grower, holds its foliage late, quite distinct, and the flowers are of a brilliant colour. Mr. Williams had this Rose three years ago from Mr. George Paul, and thinks most highly of it. *Rève d'Or* is another fine vigorous-growing Rose for a wall, a plant here being quite 20 feet in height, and the dark-coloured young foliage gives it a very pleasing appearance. There was an abundance of buds on it, and it is a very free bloomer.

*Reine Marie Henriette* is a grand pillar Rose, and the coral colour of the flowers is most pleasing; and *Noisette Madame Caroline Kuster*, pale yellow with deeper coloured centre, is a very free bloomer and a charming Rose.—D.

### STABLE MANURE.

THE communication by Mr. Jenkins on page 204 on this subject will doubtless set many gardeners and others thinking how they can improve stable manure, and thus convert it from practically useless into valuable material as he appears to do. Stable manure varies widely in its quality, and we have no idea of its condition when ejected from the stable and passed under the supervision of your correspondent. But it may be very naturally concluded that it is only of inferior quality, if his own statements are rightly judged. The manure thrown out daily from 90 per cent. of stables in private establishments is very little better than straw. In the neighbourhood of towns straw is of more value, and therefore horsekeepers



use no more than they are really compelled to do, and therefore we may reasonably conclude that the manure they have to dispose of will be as valuable as that Mr. Jenkins goes to so much trouble to prepare. It is of course concluded that he has to deal with a large per-centage of straw, the same as most of us have to contend with. Manure, whether from cattle sheds or stables, that can be purchased by gardeners and farmers, and by the latter principally relied upon in the neighbourhood of towns, is much better than the manure I could ever prepare from our stables. Sawdust and German moss are largely used in stables in the neighbourhood of such towns as Liverpool, Manchester, and others. At one time considerable trouble was taken here in the preparation of manure from the stables. It was found that plants generally did not do so well with this manure, prepared, as we thought, carefully, to prevent, by fermentation, the formation of carbonate of ammonia, which is very volatile and readily makes its escape. It is not doubted that Mr. Jenkins is following a scientific method of forming organic acids, which take up ammonia, by keeping his heap of manure moist and at a low temperature. It is, however, no easy matter to manage a heap of fresh manure from the stable with a large per-centage of straw at a temperature below 80° Fahr. Above this the escape of carbonate of ammonia is said to take place. More than once it has been concluded that a heap of manure carefully prepared to fix the ammonia was particularly rich in this ingredient, but it failed to produce the gratifying results that were achieved with purchased manure from the cattle market and horsekeepers.

Practical results of this nature led us to consider whether the heap of manure so carefully prepared was after all so valuable as had been supposed. The fact must not be overlooked that the preparation of manure on the principles advocated entails considerable labour, which must be added to the cost of the manure, and it is very questionable whether the manure is increased sufficiently in value to warrant this extra labour and outlay, for manure cannot be prepared without adding materially to its cost. At the same time, it is useless trying to fix ammonia when perhaps there is little or none to fix. The value of manures and their effect made from such materials as are thrown out of private stables, depends to a large extent upon the quality and texture of the land to which it is applied. It is observed that Mr. Jenkins only uses it in a thoroughly decomposed condition, but the majority have not supplies sufficiently ample to allow of their doing this. Supposing they had, it is an open question whether it is best applied in this condition or in a fresher state, so that its properties are naturally absorbed by the soil ready for the roots as they take possession of the soil. The properties must be materially reduced in strength if the manure is exposed to much rain, and to be continually returning this to the manure means labour and expenses. Would it not be better to use manure practically short and scatter it on the surface of the soil as it is dug, or some short time before it is necessary to crop the ground? This depends upon the time the ground is dug, and the nature of the soil. On our light land we have practised this with excellent results, and have forked it beneath the surface some time prior to seed-sowing or planting. It is generally supposed that it is best buried just beneath the surface on light soils, but it is questionable whether greater loss takes place by spreading it on the surface than by any other method of application. For heavy soils such a course is not advisable, for they are turned up and benefited by exposure to the weather nearly as much as they are by an application of manure; in fact, the action of the weather must not be prevented by any such course from carrying out its beneficial effects.

With regard to stable manure that is principally composed of straw, my course has been for some years past not to attempt to bring the straw into a decomposed condition. As much has been dried and stored as required for covering the ground amongst fruiting Strawberries to keep the fruit clean. Some given to the men for their pigs, and a good portion carted away to the farm for bedding. The short material has proved to be doubly valuable, and effected a considerable saving in labour. Less of it is required on the land, and this means unmistakable economy, for labour spent in preparation and wheeling an extra quantity on the flats will more than buy any extra manure required. Short material is much more advantageous for our land than long straw decayed by any such process advanced by Mr. Jenkins. For heavy land, say such as Mr. Iggulden must have at Marston, long half-decayed manure formed by a similar process to that described on page 204 would prove of great value if only to keep it open and porous, so that air and warmth would have a better chance of penetrating it.

It may be brought forward that there are many who must make use of the material thrown out of the stables or go without. This may be very true, but it does not alter the fact that the most economical method of procedure is not adopted. In the neighbourhood of towns where straw is wasted in the manner I have described, many would gladly fetch it away if dried, and return the manure

after its conversion into superior material to what it would ever make by any attempt at decomposing it. Such a method would prove far more economical and advantageous to gardeners, especially those who have light soil to deal with, than would arise from daily attention to insure it being kept at a very low temperature.

I am not writing to disparage those who are trying to make the best of what they have, but to point out that trying to fix ammonia is only a waste of labour when there is little to fix.—WM. BARDNEY.

### KITCHEN GARDEN WALKS.

It too often happens that kitchen garden walks are neglected. It is thought that as they are not in the pleasure grounds it does not matter in what condition they may be so long as they can be walked or wheeled on; but this is a mistake, as a substantial tidy walk in a vegetable garden is always valued, especially in winter. I do not approve of having very wide walks in a vegetable garden where space is limited. It is seldom anyone wishes to drive a carriage and pair through the kitchen garden, and if the walks are capable of accommodating two abreast, or allowing two wheelbarrows to pass each other without having to break down the edging, nothing more need be desired as a rule. But it is not with the width of walks generally that fault can be found so much as their condition, especially in winter, and it is better to have a 6 feet walk in good condition than one 10 feet or 15 feet wide in bad order. There is no economy in deficiently made walks; as they will take much more labour to keep them in repair than it would take to make them properly, and it is astonishing how little repair a thoroughly well-made walk requires.

If any repairing or alteration is required now is the time to attend to it. If the foundation is soft dig it out, as it is impossible to keep up a walk over a marshy bottom. Go down 2 feet if necessary, and in all cases of a deficient foundation go down 18 inches at least. Put plenty of large stones in the bottom, and make the surface of some material that will bind. Keep the middle 3 inches higher to every yard width of the walk than it is at the sides, and there will always be a comfortable footway no matter what the weather may be. If the walk is a yard wide make it 3 inches higher in the centre than at the sides; if 6 feet have it 6 inches, and so on. Edge with boxwood, tiles, stone, or wood, which should also be kept in trim.—A KITCHEN GARDENER.

### VIOLAS.

THE notes on the above are very interesting and profitable, inasmuch as the Viola is calculated (at no great expense) to contribute in a most distinct and telling manner to the adornment of our flower gardens. Few, if any plants, can compete with them for general usefulness and effect. For fully seven months of the year Violas may be had in bloom, and some even push their way through the snow in early spring, and are gay almost with the Snowdrop and Crocus. They are quite hardy, readily propagated, easily managed, and mostly bloom simultaneously, consequently ought to be, and I believe are, destined to be the most popular of all bedding plants. With ordinary cultivation in the south they will answer admirably for spring and early summer decoration, and with careful planting, as pointed out by Messrs. Jenkins, Baxter, Dean, and others, will be equally useful all through the season, whilst in the midlands and the north they should form the "backbone of our spring and summer bedding."

Of 8000 Violas and bedding Pansies planted here for stock there was not a single failure, and the season has certainly not been in their favour, rather to the contrary. Of course, odd plants died, but every row has been a perfect line of colour. For bedding and massing I would strongly recommend good self colours—the best grown here being Countess of Hopetoun, white; Bullion, yellow; Archie Grant, purplish blue; Mulberry, the name correctly indicating the colour; Duchess of Sutherland, lavender; Ardwell Gem, primrose yellow; Queen of Lilacs, soft pleasing shade of colour. We have not a good blue of the Blue King Pansy colour, but this Mr. Dean promises to supply in his True Blue.

For exhibition, if they aspire so high, the best would embrace the most of the foregoing, with the Fancy or parti-coloured varieties, such as Countess of Kintore, Pantaloon, Mrs. Baxter, Mina Baxter, Unique, Dawn of Day, Skylark, and York and Lancaster, this latter variety being very distinct in early summer, and in every way desirable. These parti-coloured varieties are also very useful for bedding, massing, and general garden decoration, but are not in such demand as the selfs. It is strange that Mina Baxter has not found its way into Mr. Steel's good graces. Here it is most distinct; good dwarf habit and constitution, as Mr. Steel admits, and flowers almost crimson, the top petals regularly barred white.

In attempting to define the difference between the Viola and Pansies might I suggest that the blotch be the one distinguishing feature? It is quite evident that if they are for exhibition as cut flowers the distinction must lie in the flower, or there would be no end of quibbling. We must not allow habit to be the criterion, as many

Pansies might then have claim to be classed as Violas, and numerous Violas would find their way into the list of Pansies. Neither is there necessity to pursue a course calculated to deprive us of some of the best Violas—viz., calyx with unequal sepals. Our aim should be to bring the whole family of Violas to resemble in shape Countess of Hopetoun, whose faultless flowers place it far ahead of most existing kinds.

By adopting my suggestion that the blotch be the characteristic of the Pansy, and the absence of the blotch or rayed centres to distinguish the family of Violas, we would lose only such as Holyrood Sovereign, Blue King, which are all received as Pansies, whilst we should retain all that are entirely without markings, such as Bullion, Countess of Hopetoun, Golden Queen of Spring, &c., and all rayed varieties, such as Pilgrimage Park, Ardwell Gem, &c., and nearly all fancy kinds in the way of Countess of Kintore, Mrs. Baxter, York, and Lancaster, &c. In my conversations with Mr. Dean or Mr. Baxter I have always forgotten to mention this perplexing subject, but now that it is under discussion it is to be hoped that it will be satisfactorily and finally disposed of.—**JOHN HARKNESS, Bedale.**

## CHRYSANTHEMUM NOTES.

### THE HULL CHALLENGE CUP.

BEING much surprised at the tone of Mr. Jameson's remarks on pages 401 and 402, I have carefully read my note on page 387 in order to see if I could find anything that would account for such an expression of feeling. I do not find a word that can fairly be interpreted as even guessing "the reasons actuating the Committee of the Hull and East Riding Chrysanthemum Society in this matter," far less do my remarks attribute "unworthy motives to the Committee." I repudiate the suggestion of such thoughts or intentions. I have no reason to suppose the members of the Committee of the Hull and East Riding Chrysanthemum Society—collectively or individually—to be other than men of honour and integrity, and I do not think any of them would knowingly and wilfully commit an act of moral injustice to anyone; and I think that Mr. Jameson will, in calmer moments, regret that he has hastily attributed to me suggestions and insinuations that had no existence either in my thoughts or my words. I did not suggest that the Hull Committee were acting under Rule 15 in this matter—my remarks, so kindly quoted by Mr. Jameson on page 402, being sufficient proof that I had in my mind other possible reasons for their action—consequently, your correspondent, in his haste to show how I had "entirely failed to grasp the facts of the case," plainly exhibits his own failure to comprehend accurately the meaning and intentions of plain language. Mr. Jameson credits me with considering myself "qualified to sit in judgment on the case," and in doing so he credits me with far more vanity than I possess, although I admit not being alone in the possession of a fair share of it; but I may say I have known solicitors to err in their judgment; and it is generally admitted that the soundest advice they give their clients is when they advise them to have "nothing to do with law." In the present case the Hull Committee had no other alternative to their action; but on reflection I am of opinion that Rule 15 would not shelter them, even if they were disposed to place themselves behind it, and their solicitor had advised that course.

When I see a case of public interest that involves a positive hardship to an individual, and the hardship arises through what I conscientiously believe to be a pernicious principle attending such case, I hope my "own good sense" will always be backed by sufficient moral courage to enable me to draw public attention to the matter.

As regards the principle of challenge cups for individual competitors, there has not been a reason given why such a system should be applied to Chrysanthemums any more than to any other product of the garden. If such a cup or cups is offered annually for any other garden product I shall be pleased to be informed of it; what it is for, and where it is offered.

I am very glad to find that I have drawn from Mr. Jameson a clear statement of the facts in *re* Mr. Mease and the Hull Committee, consequently I think my original remarks were not written quite in vain. I feel sure that neither Mr. Mease nor any other right-thinking person would impute wrong motives to the Hull Committee.—**J. UDALÉ, Elyford.**

P.S.—I suggest that in the future a clause be inserted in schedules issued by societies offering a challenge cup, distinctly stating that the death of an employer will invalidate the claim to a cup that has not been finally won; exhibitors will then know what they are doing, and no hardship will be inflicted upon them. The case of Mr. Mease has forcibly illustrated one of the serious flaws incidental to the system of competition for challenge cups.

[It is fair to Mr. Udale to state that in a note accompanying his former communication he said he "did not in the least wish to injure the Hull Society or Show."]

### MR. MEASE AND THE HULL CHALLENGE VASE.

I HAVE to state that in consequence of Mr. Lindsay's letter in the Journal of 10th inst., announcing the withdrawal of Sir Thomas Edwardes-Moss from the competition for the challenge vase, the Committee are enabled to allow the executors of the late Mr. C. W. Neumann to count last year's win, and Mr. Mease has been informed of this.

With regard to the reason Mr. Lindsay gives for the course adopted, I wish to say for the information of those who are unaware of the fact,

that the Judges last year were Mr. George Gordon and Mr. John Wright, and they have been reappointed this year in conjunction with Mr. Wm. Kipps of Walton Lea, Warrington. Comment on these names is unnecessary, but I may say that they are published in the schedule which was issued and sent to all previous exhibitors last spring. I should also like to add that Mr. Wright and Mr. Kipps judged at the Liverpool Show last year, and have, I understand, been reappointed this year.

I omitted to say in my letter of last week that instances having come within the cognizance of the Committee of employers having refused their gardeners permission to compete, the then Chairman, Mr. George Bohn, with a view of inducing them to do so, offered this challenge vase as an addition to the money prize of £10 previously given, and it is within my knowledge that it has had the desired effect. This, of course, benefits the gardener as well as the Show.

I wish to draw particular attention to the fact that the challenge vase was an *addition*; the Committee did not rob Peter to pay Paul, but continued the same money prize, and this year have increased it to £15.—**R. FALCONER JAMESON, Chairman Hull and East Riding Chrysanthemum Society.**

## HORTICULTURAL CLUB.

THE usual monthly dinner and conversazione took place on Tuesday evening the 8th inst., when there was a large attendance of members. Mr. P. Crowley, in the absence of Mr. John Lee, presided; there were also present the Rev. W. Willis, the Rev. F. H. Gall, Messrs. Girdlestone, H. J. Pearson, Chas. Pearson, T. W. Girdlestone, L. Upcott Gill, W. J. Jefferies, J. Walker, Francis Rivers, E. B. Lindsell, and the Secretary, Mr. James Walker of Whitton was elected a member.

In the evening an interesting conversazione on the Chrysanthemum took place. Mr. J. Laing of Forest Hill kindly sent some dwarf plants to illustrate his method of culture, and Messrs. Davis & Jones of Lilford Nurseries a box of some of the newer varieties. The subject was introduced by the Hon. Secretary, who stated that while he had been for many years a cultivator of the flower, it had been for his own enjoyment, and not for the purpose of exhibition. He had been longer a cultivator of them than anyone in the room, and referred to the years gone by when Mr. James Salter of the Versailles Nursery, Hammer-smith was *the* great cultivator, and the introducer of all the new varieties. At that period and for many years afterwards there were no Japanese varieties, and when they were first introduced they were cried down by florists as "ragged jacks;" since then opinion on them had greatly changed, and they were now the most popular classes, and it was a remarkable fact that while all the new, or nearly all, incurved varieties were sports, the number of Japanese seedlings seemed to be unlimited, for not only were they raised in Europe, but new varieties were yearly being introduced from Japan and China. He mentioned that one firm alone—Delaux—had this year advertised a hundred new varieties, or so-called new. It seemed to him that, as it was with the Rose, there were many who considered size to be the chief object to be looked for, and this he believed to be a mistake. The plants sent by Mr. Laing's treatment, which he considered the best for general use as ensuring dwarf plants and good blooms, was described. The plants are struck in the usual way in January, they are allowed to grow without stopping, repotted as usual, and then about the middle of June are cut down to within 6 or 7 inches; they then break, and three or four shoots are allowed to grow, and thus nice bushy and well-finished plants not higher than 4 feet are obtained. These, as soon as the flower buds show, are disbudded, and with the result as shown in the plants exhibited—dwarf habit, with good and large blooms, quite large enough for any purpose.

The Rev. W. Wilks cordially approved of Mr. Laing's plan, and deprecated the growing of plants some 6, 7, and 8 feet high, which required a 6 foot step ladder to be used in order to see them. He also felt that the immense sizes obtained was no advantage, and that moderate sized blooms were far more elegant. He also thought that disbudding was carried too far, and that many varieties were much better without it.

Mr. Charles Pearson, having first kindly read a paper by Mr. Laing which appeared in the "Scottish Gardener," said that he had devoted a good deal of time and thought to the question of disbudding, and that he felt persuaded there were several varieties which were much better for not being so treated; that if they were they did not give satisfactory flowers, while if they were left in their natural state they were much more beautiful, and were covered with bloom; and that, therefore, indiscriminate disbudding had to be avoided. He gave a list\* of those which he had found were better if left in their natural condition. He also stated that he believed hard potting tended to the dwarfing of the plants, and that he had latterly rammed them quite hard when potting. He also considered that the plan of plunging the pots was a bad one, as the roots ought to have the benefit of the sun's action as much as possible, and it was most probably only used to save trouble in watering. The loss of foliage in the lower part of the stems was attributed to carelessness in this respect.

[The list arrived too late for insertion, but most of the varieties are named on page 401 last week.]

## ADVICE TO JOURNEYMEN GARDENERS.

WITH your kind permission I wish to give a few remarks for the above readers of the Journal. Several years ago I went as journeyman in the houses, under a well-known and much respected gardener in this country. The first advice he gave me was to keep a diary of operations

in the gardens. I have been very grateful to him for that advice. During the three years I was employed in the gardens in question I kept a diary of the work in progress, inside and out, which I am glad to say has been of great benefit since, hence my reasons for drawing young gardeners' attention to the subject. This time of the year is as good a time to commence as the beginning of the year; for instances, starting Vines, and preparing other plants for forcing, for supplying fruits and flowers for another year's demands. By taking notes of plants that are forced to be in at a given time—for example, *Deutzia gracilis*, make a note when it is placed in heat, also when in flower; by so doing anyone will be able to tell within a few days how many weeks it takes to force the above plant into flower. The temperature of the forcing house will act as a guide. There are many other ways young gardeners can employ themselves in their spare time, such as taking note of plants that are most useful for house, table, and other decorative purposes. I would advise beginners, especially those employed solely inside, to give the outside a good share of their attention, particularly the kitchen garden. The way that I found answered well was to make a note of the previous crop to the one put in. Peas, for instance, name of the variety, when sown and gathered. In some places the kitchen gardens are situated some distance from the other part of the garden. In such cases, where it is not convenient to look round every day during the busy part of the season, once a week would answer. Enough has been said, I think, to impress on the minds of young gardeners the advantages derived from keeping a diary.—M., *Lancashire*.

### CANKER IN FRUIT TREES—BULLFINCHES.

It is quite useless, I suppose, for me to say anything more on this subject in the Journal after Mr. Burton and the Editor, on page 226, appear so well satisfied that some new growth of wood has resulted from treatment of the roots. What the treatment was we are not informed. Time must prove whether the insects, which are acknowledged to be present, are innocent, and as to whether the canker will show on the new growth. "Wait a wee," examine, and report again in two or three years, and I shall be interested to know if they remain healthy.

I am well satisfied with another year's experience of my plan. All the treatment at the roots that my trees have received is a treat occasionally in the way of a few bucketfuls of liquid manure during the past unprecedented dry season, and they have borne some of the best fruit I have had, and the trees, which were almost dead with canker, are now as healthy as any I have and desire, irrespective of sorts and situations. Mine is not the only case. It so happens that I can enclose a Ribston Pippin Apple from a tree which a few years ago was condemned, and was about to be grubbed up as useless, so badly was it cankered. I advised my neighbour, Mr. Allan Thornton, seedsman, &c., to try a good dressing of stem and branches with a strong insecticide. He used Gishurst compound, and the result is that it is nearly cured, and bears finer fruit than it ever did before, and this without disturbing a root.

Next to canker and blight—*i.e.*, periodical visits of aphides, in order of destructiveness to fruit trees, come bullfinches. These birds are more numerous this season than ever noticed before. This means a lot of trouble and mischief later on if they are not destroyed or caught. Some years ago I remember recommending catching them for many reasons in preference to shooting them. Within the past few weeks I have taken thirty-nine in trap cages within a few yards of the house door, the cages being hung against the buildings out of the reach of cats. This is no doubt a comparative clearance from the neighbourhood, as they fly from garden to garden in search of berries in the autumn, and later on destroy the prospect of the coming season by taking off the bloom from most kinds of fruit trees, especially Plums, Cherries, Gooseberries, and Currants, and to some extent Apples and Pears. House sparrows, which are almost as destructive to fruit buds as bullfinches, and large tits (*Parus major*), which are very fond of pecking holes in Apples and Pears, as well as destroying nuts, before they are ripe, and which are very destructive to Green Peas, are easily caught in the same way.—J. HIAM, *Astwood Bank, Worcester-shire*.

[The Ribston Pippin is good, but its appearance marred by numerous specks, especially on the shaded side. With better root action, consequent on better growth, the crop will probably be still farther improved next year. We have never denied the advantages gained by Mr. Hiam through dressing his trees, and possibly after further experiment we may have to say something in favour of his plan.]



### ORCHIDS AT MORDEN PARK.

READERS of the Journal would learn from Mr. L. Castle's remarks, which appeared the week before last, that Mr. C. Gibson, gardener to J. Wormald, Esq., has again some grand Chrysanthemums. I venture to assert that had he the convenience to grow

Orchids, he would be quite as formidable a rival at the great summer shows as he is at the Chrysanthemum exhibitions, but his plants are restricted to one house associated with other occupants usually found in a stove. The stages formed of slate slabs are 5 feet wide, and a small crevice is made between the walls and stage above the hot-water pipes to allow the heat to circulate better among the plants. *Dendrobium Parishii* growing on blocks with a little sphagnum and suspended are a dozen fine pieces, having growths from a foot to 14 inches long. They increase in size each year, as may be seen by the old pseudo-bulbs, some of which are not more than an inch or two in length. *D. cretaceum* is equally good under the same treatment; *D. Dalhouseianum* is represented by a very fine specimen with fifty growths, and last summer bore twelve dozen spikes of bloom. Another plant of the same size is *D. Paxtoni*, growing vigorously in a large pot. This blooms at different times of the year, and its beautiful orange and brown flowers are always admired. *D. formosum giganteum* in a 9-inch pot is also grown well. Other species showing the same care bestowed on them are—*D. aggregatum majus*, *D. chrysanthum*, *D. densiflorum*, *D. nobile* and the variety *pendulum*, *D. Pierardi*, *D. primulinum*, *D. pulchellum*, and *D. suavissimum*. *Cymbidium Mastersi* with about thirty growths, and well furnished with flower spikes, will soon be in perfection; there are already twelve blooms open on some of them. It is much like *C. eburneum* in its habit of growth, but the flowers are smaller and different in shape; they are produced during the winter months, and remain fresh for a long time. The compost used for potting is rough peat. *Sobralia maerantha*, which would make a fine plant for exhibition, is growing in a 13-inch pot with a hundred or more growths, and would evidently enjoy a good shift, for the stems are coming up quite close to the rim of the pot, and are produced so closely together that it is only just possible to see through it.

The *Calanthes* on a shelf over the path are sending up spikes, and the useful *Cypripediums*, *C. barbatum*, *C. insigne*, and *C. villosum* are also grown. As I have already stated, Mr. Gibson has not sufficient space at his command, but he certainly knows how to make the best use of what he has. Besides the shelves and stages full, there are many suspended from the roof, including good plants of *Oncidium ornithorhynchum* showing flower, *Aerides odoratum*, *Cœlogyne cristata*, *Cattleya Trianae*, *Stanhopeas*, &c., and below these are *Lycastes*, *Peristeria elata*, *Saccolabium giganteum*, and various *Cymbidium*s and *Oncidium*s. The Orchids, as well as every part of the garden, prove that Mr. Gibson is not only a successful Chrysanthemum grower but a thorough gardener.—G. W. CUMMINS.

### ORNAMENTAL TREES AND SHRUBS.

THE TULIP TREE.—Botanically this is known as *Liriodendron tulipifera*, but the common designation is a fitting title, as the curious and interesting flowers are very like a Tulip. As the tree comes into foliage in early summer the leaves are of a very soft green colour, curiously cut and very ornamental; then they become darker, and in late October they assume a bright golden yellow colour, which is more intense than any other leaves of this hue. It is in June the crowds of blooms appear, and their decided Tulip form, as well as their green and creamy colour, at once attract attention. It is strange that with all these good points Tulip Trees are not more planted. There should be at least one in every garden, and in large gardens they may be planted more freely with advantage. About eight years ago we planted half a dozen Tulip Trees. The soil was not the most favourable, but they have done well, as they are now from 10 feet to 14 feet in height, and they are bushy and healthy. I can therefore assert that they do not require special or extra good treatment to make them succeed, and my experience is that they are as easily grown as any tree I could name.

SWEET BAY.—The well-known *Laurus nobilis* is not absolutely hardy, as I have known it to be injured by frost and a severe winter in Scotland, but that is only in exceptional years, and I never knew it to be killed in the south or in mild localities. Here it grows luxuriantly, and if sheltered in cold districts it might almost be depended on to succeed. It is worth trying everywhere, as it has the deepest green leaves of all bushes; its fragrance is very agreeable. The plants are very pretty when of conical form, and large clumps of them are also exceedingly effective. If the bushes are small and severe weather comes they can be easily drawn together by a string and then covered, but this practice will not often have to be put into operation. Plants are very effective amongst other trees and shrubs, and if planted in the spring months they will become established before the summer is over.

KALMIA LATIFOLIA.—This comes under the heading of American plants, and there are several *Kalmias*, but in my opinion none of them equals the one named above in the great beauty of its flowers. It is a bushy shrub with foliage not unlike a Laurel, only the leaves are smaller. It is a good evergreen when not in flower, and when in blossom nothing can excel its pleasing appearance. The soft pink blooms are produced in showy clusters at the end of each shoot; they are very neat in outline, and so beautiful as to make them welcome in the most choice



cut flower arrangement. The plant is quite hardy, but it likes a little shelter, and it keeps up its American character by doing best in a mixture of peat, loam, and sand. A bed of *Kalmias* is a grand feature, and in planting them in this way the whole of the old soil should be taken out of the bed, refilling it to the depth of 2 feet 6 inches with the compost recommended. In planting single specimens a few barrowloads of old soil should be taken out, filling up with some of the proper material before planting.

**HARDY AZALEAS.**—I am reminded of these at the present time, as some large bushes here are glowing with their rich autumnal tints, and they are objects of special beauty twice a year. It is impossible to over-estimate the beauty of these Azaleas when in flower in early summer, and all who grow them will be attracted by their exquisite colours and delightful fragrance. They come out with the *Rhododendrons*, and although these may be more glaring than the Azaleas they are not so pleasing. Little groups of them in small gardens are always valuable, and where there is much pleasure ground or good woods they may be scattered about profusely. They delight in a sandy and peaty soil, but will also grow in ordinary material. They are deciduous, and may be planted a little while before the leaves fall in autumn or any time during the winter. As they do not grow very fast it will be many years before they attain the proportions of large bushes, but they are always compact, and therefore admirably adapted for small gardens. There are single and double-flowering varieties; all are pretty, and should always be planted in variety. The mixed colours of these Azaleas are so pleasing that I would plant four or five dozen varieties.

**HALESIA TETRAPTERA.**—This is commonly called the Snowdrop Tree, and is not very often planted, but it has a good habit of growth with pleasing foliage, and when in flower in early summer it is highly interesting, as the branches all bear a large number of pendant white flowers, which have a strong resemblance to the Snowdrop. It will grow freely and bloom profusely if planted in any garden amongst a general collection of trees, and all who know anything of good shrubs will always regard it as valuable.—J. MUIR.



WE desire to THANK CONTRIBUTORS who have favoured us with reports of Chrysanthemum Shows, and notes on other subjects of interest, though all of them cannot be promptly inserted during the brief period of the November exhibitions.

— A CORRESPONDENT writes:—"I do not think much of Mr. Winkworth's contrivance for MEASURING CHRYSANTHEMUMS, for the reason that it only gives the horizontal diameter, which in itself is very misleading in regard to the actual size and quality of the flowers. It is a common occurrence for the ugliest and worst of flowers to give the greatest horizontal diameter."

— WE regret to learn that the well known continental rosarian, M. FRANCOIS LACHARME, died at Lyon on the 5th inst. M. Lacharme was born at St. Didier-sur-Cheronne, France, on January 28th, 1817. He was the son of an agriculturist, but early formed a liking for Roses, and in 1836 was apprenticed to M. Poncet of Lyon. He afterwards spent some time in Paris, and in 1840 took Mr. Plantier's nursery at Lyon, where he has since raised many fine Roses, of which we may mention Alfred Colomb, Captain Christy, Charles Lefebvre, Comtesse de Serenye, Hippolyte Jamain, Louis Van Houtte, Madame Lacharme, Victor Verdier, Violette Bouyer, and Xavier Olibo amongst the H.P.'s, and Madame Willermoz and Madame Lambard amongst the Teas.

— AN Aylesbury correspondent writes:—"Having taken the Journal in for many years, may I ask your assistance in again obtaining two or three plants of *PRIMULA EROSA*? for I have applied unsuccessfully to several nurserymen who were likely to have it. A few years ago I had any quantity, and distributed it largely amongst my friends, but it is gone both from my own garden and theirs. I think if the Journal would kindly notice this want, and ask for information where it may be now obtained we should hear of it, and I could regain my lost pct."

— THE beautiful CONSERVATORY AT ABBERLEY HALL, STOURPORT, is rendered gay just now by the very fine collection of Chrysanthemums grown by Mr. Young. There are fine blooms of such varieties as Lady Selborne, Fair Maid of Guernsey, Dr. Macary, Elaine, Mrs. G. Rundle, Madame C. Audiguier, Mr. Bunn, King of the Crimsons,

Lord Leicester, Empress of India, and Queen of England. Besides plants bearing flowers of exhibition quality, others are grown in bush form for decorative purposes, and these are now a mass of bloom.

— A SOMEWHAT large collection of *BOUARDIAS* is grown at Dover House, Roehampton, and the plants are of the utmost value in affording bright and fragrant flowers for cutting. They are sturdy little specimens a foot high, growing in 5-inch pots, and are flowering profusely. Several varieties are grown, including Priory Beauty, soft rose, very free; Elegans, rosy red, also very floriferous and useful; Dazzler, bright scarlet; Vreclandi, white; President Garfield, double, pale salmon, a well known and beautiful variety; and Alfred Neuner, double, pure white, free and good.

— WE have received from Sir Archibald Dunbar of Duffus House, N.B., specimens of fruit grown in the garden there which challenge the productions of our more favoured southern climate. We have seen some very fine specimens of Grosse Calebasse Pear, but we have no record of any exceeding that which is now before us, which is 9 inches in length and which weighs 1 lb. 14½ ozs.; Gansel's Bergamot is nearly 11 inches in circumference, and weighs 14 ozs.; Doyenné du Comice weighs 10 ozs.; Haeon's Incomparable, 11 inches in circumference, weighs 12 ozs.; Sinclair, 4½ inches long and 3½ inches in diameter, weighs 11½ ozs.; and Durondeau, 5½ inches long, weighs 13¾ ozs. A splendid specimen of Peasgood's Nonsuch Apple was the finest we have ever seen, being 14½ inches in circumference and weighing 1 lb. 3½ ozs. The conditions under which these were grown will be found in the following communication which accompanied the fruit:—"The garden is situated between the county town of Elgin and the shores of the Moray Firth, sheltered from the north by a hill which rises about 200 feet above the level of the sea, while the garden is only about 55 feet above sea level. Sir A. has had a sort of experimental garden here for upwards of forty years. He now finds that only about one-fourth of the varieties of Pears mentioned in Dr. Hogg's valuable descriptive catalogue, tried here, succeed, and these only on the walls. Both early and cooking Apples do well; but late varieties of first-rate Apples also require a wall. A few varieties of Plums and Damsons succeed and bear abundantly, and all sorts of Geans and Cherries are almost a certain annual crop. Being anxious to encourage fruit-growing in these parts, Sir A. gives grafts or cuttings freely."

— MR. JOSEPH MALLENDER sends the following SUMMARY OF METEOROLOGICAL OBSERVATIONS AT HODSOCK PRIORY, WORKSOP, NOTTS, FOR OCTOBER, 1887:—Mean temperature of month, 44.9°. Maximum on the 28th, 58.7°; minimum on the 26th, 24.0°. Maximum in the sun on the 2nd, 103.6°; Minimum on the grass on the 26th, 17.2°. Mean temperature of air at 9 A.M., 45.3. Mean temperature of soil 1 foot deep, 46.7°. Nights below 32° in shade, five; on grass twenty. Total duration of sunshine, ninety-one hours, or 28 per cent. of possible duration. We had seven sunless days. Total rainfall, 1.74 inch. Rain fell on fourteen days. Maximum fall in twenty-four hours on the 8th, 0.62 inch. Wind velocity exceeded 400 miles on two days, and fell short of 100 miles on three days. Average velocity, 9.1 miles per hour. Approximate averages for October:—Mean temperature, 48.2°. Rainfall, 2.84 inch. Sunshine (six years), eighty hours. Another dry and very cold month. The mean temperature is lower than any of the last ten years except 1880, when it was the same. The nights were especially cold, and the number of frosts on the grass is very large.

— CARTER'S PROVIDENT SICK FUND.—The second annual meeting was held on Tuesday, the 8th inst., in the warehouse of Messrs. James Carter & Co., Queen's seedsmen, High Holborn, one of the spacious floors being specially cleared for the purpose. It was attended by about 250 members, who by the keen interest displayed in the proceedings showed their appreciation of the benefits which had been obtained by the establishment of the fund. The chair was occupied by the manager, Mr. C. H. Sharman. The report and balance-sheet were read and adopted, various suggestions for increasing the usefulness of the Society being given, and the necessary amendments of the rules made. During the second year of the Society's existence the number of members on the register had risen from 268 to 353, all of whom were employed in various departments of the business. A further sum of £20 was added to the reserve fund. A donation of £10 was made to the Hospital Saturday Fund, and not the least pleasing feature in the meeting was the solicitude displayed by the members to make a provision so early in the Society's existence for the assistance of widows or orphans of deceased members,

and a proposition was made that a subscription should be given to the Gardeners' Orphan Fund recently established, and which it was thought would secure the objects in view; but after a fair discussion it was seen that the benefits to be derived from that source would necessarily be very limited in extent, not being available for the relief of any but the orphans of managers or departmental foremen in nursery and seed establishments. An amendment was therefore proposed and carried unanimously that the reserve fund should be charged to the extent of £10 per annum for that object when required. The officers and members of the Committee were re-elected with acclamation, and a hearty vote of thanks for the chairman brought the proceedings to a close.

— FERTILE HYBRIDS.—“It is perfectly amazing,” says the “American Gardeners' Monthly,” “how much work is needed to drive the great error out of the world that hybrids are generally sterile, simply because that much-abused beast, the mule, happens to be commonly (though not absolutely) sterile. Instances of the reverse are continually before us. One of the most useful is the success of Mr. Carman of the *Rural New Yorker*, in getting a productive race of grain between Wheat and Rye. He has also been very successful in getting the Blackberry and Raspberry to unite, though Mr. Wm. Saunders of London, Canada, has occupied this part of the field before him. Latterly Mr. Carman has been successfully crossing different species of Roses, and has seedlings, but we do not yet know that the hybrids are fertile or sterile.”

— GRAPES AT IPSWICH.—The following cutting from the *Suffolk Chronicle* has been forwarded to us, as referring to an old reader of this Journal:—“Mr. John May and his gardener are to be congratulated upon their success as Grape growers. For five years in succession at Ipswich autumn Show Mr. May has beaten the district. In fact, he has never been beaten since he exhibited. His fruit is remarkably fine and we daresay the quality is no less unexceptional. The competition is on no limited scale. The country houses, whose vineries lack no means and appliances for perfect cultivation, enter the lists, only to take subordinate position to Mr. May. We like to encourage generous rivalry in such peaceful contests. Other growers had better make up their minds to beat Mr. May—if they can.”

— A COLONIAL paper thus describes a HUGE GRAPE VINE:—“There is a Grape Vine in Carpenteria, the property of Jacob Wilson, that exceeds the famous Montecito Vine that was forwarded in 1876 to the Centennial. At the butt it measures 5 feet 10 inches, and 5 feet from the ground 5 feet 2 inches. It is of the Mission variety, and is reputed to be the largest Grape Vine in the world. It is supported by a trellis, covering an area of ground almost 100 feet square. Mr. Wilson informs us that the Vine, two years ago, produced four tons of Grapes.”

— JUST as we are going to press we learn that at the HUDDERSFIELD CHRYSANTHEMUM SHOW, held on the 11th inst., the £10 prize for the best forty-eight cut blooms was won by Mr. A. R. Cox, gardener to W. H. Watts, Esq., Liverpool. For twenty-four varieties, twelve incurred and twelve Japanese, Mr. J. P. Leadbetter, gardener to A. Wilson, Esq., Hull, won the premier prize, other exhibitors being Messrs. Cox, Hargreaves, Daniels, Stokes, W. Smith, J. Bubb, and J. T. Sharp. Groups were also well shown by Mr. J. F. Brigg and Mrs. J. W. Taylor, who were first and second. The Show seems to have been very satisfactory.

### THE SOIL

[A paper read before the Paxton Society, Wakefield, October 29th, by Mr. D. Gilmour jun.]

WHEN we gaze upon a forest of trees in all the beauty of their full foliage, or pass by a well kept farm at harvest time, where we see the golden grain ripe for the sickle, or visit a range of plant houses where are all the most lovely and interesting specimens of floral life collected together for man's pleasure and gratification, it is difficult to imagine that at one period of its history the surface of this earth was nothing but a solid rock. I believe that some scientific men go so far as to say that at a still earlier date the whole of the elements of this globe—air, land, and sea—were in a gaseous state, and simply consisted of vapours. However, we do not need to go back so far as that, but will content ourselves with making a commencement with the rocks.

Most of us will have noticed that the surfaces of the stones used in our buildings, when these buildings have been erected some years, are subject to a kind of decay; it is a very slow process, slow, but sure. It is this process going on in the world for countless ages which has produced the soils which we cultivate at this present time. There is a certain element in the air we breathe called oxygen, necessary to all vegetable and animal life, and it is this element which gives us life, to

which most of, if not all, the decay and change in the world is due. If we examine the face of a cliff or crag which has been exposed for some time to the action of the weather, we find it gradually crumbling away. It may be very slowly, or it may be rapidly. This crumbling away naturally produces a quantity of loose material, in the more minute portions of which seeds become fixed and gradually form soil. So it was in the first instance. The rains and winds that beat upon the smooth face of the rocks gradually wore them away and formed a little soil in which the lower forms of vegetable life appeared. This oxygen I spoke of forms about one-fifth of the atmosphere; it forms nearly the whole of water also, 9 lbs. of water containing 8 lbs. of oxygen. It is easy to see, therefore, that water assists change and decomposition very much. There is another element which is often present in both air and water, which much assists oxygen in its efforts to produce decay and decomposition, and this is carbonic acid gas, of which I may have to speak again.

If a portion of soil be examined it will be found to consist of two parts, organic and inorganic, the organic parts consisting of remains, animal or vegetable—flesh or wood for example—and the inorganic being pieces of stone, earth, or metal.

The greater portion of all soils, except peat, consists either of sand, clay, or lime, and soils generally contain all three. The sand has been derived from the decay of sandstone rocks, the lime from limestone or marble, and the clay from slate. But a good garden soil contains other elements besides these three—the organic part before mentioned, consisting of animal matter, bits of wood, straw, hay, the roots of grasses, and the remains and dung of animals. If we go further and get a chemist to prepare an analysis of the soil, we find it generally contains all the following materials:—Organic matters, silica, alumina, lime, magnesia, oxide of iron, oxide of manganese, potash, soda, ammonia, chlorine, sulphuric acid, phosphoric acid, carbonic acid.

To enumerate all the things that man takes out of the soil would be to name everything on the face of the earth. The soil is the grand storehouse from which all life, animal and vegetable, draws its food. If we had a garden, and were to keep on growing vegetables in it, and removing the same year after year, there could be eventually only one result. No matter how rich the soil; no matter what efforts we made by digging and trenching, there would come a time when the garden would refuse to grow anything, the crops would gradually dwindle away and diminish in quantity, and finally fail altogether. Why? Simply because our successive crops go on removing certain constituents from the soil; and there being only a certain quantity of these constituents there to begin with, they must come to an end sooner or later. This will be news to some beginners, who imagine that with the purchase of the plants and shrubs they wish to cultivate, and planting them, their duties cease. Now were these persons to purchase a horse or a dog, it would hardly be necessary to point out to them the advisability of occasionally giving it a meal of some kind. So it is with plants and flowers, and it will be found that he who grows the finest flowers, fruits, and vegetables, generally has a goodly heap of manure and old turf somewhere on the premises.

Wherever we turn our eyes we see the improving hand of man, and we generally see chemistry going hand in hand with him in his improvements. Not very many years ago it was the fashion to scoff at chemistry when applied to agriculture. Intelligent farmers and gardeners now, however, have abandoned this, and gladly welcome the assistance of science in the cultivation of the soil. Unfortunately for horticulturists, the efforts of agricultural chemists have been naturally almost entirely directed to agriculture; and thus, although we can refer to probably more than a dozen analyses of Wheat and other farm crops, we cannot obtain one which gives us any information about flowers. In my own little experiments in Rose culture I am always brought to a stand by my ignorance of the chemical constituents that go to make up the plant and flower.

If we wish to get the best results from the soil, we must endeavour to arrange that it shall contain all the ingredients necessary to the growth of the crop. It is not enough to know that there is the quantity of each constituent present, there must be more; and further, it must be in such a state that the roots can readily absorb it; the plant must not be kept waiting for food; the food must be in readiness when required. When we dress our soil with good stable manure, and plenty of it, we supply it with all the ingredients that a general crop requires—that is, supposing a soil to be fairly fertile, neither containing any injurious substance in such quantities as to be detrimental to vegetable life, nor wanting in anything not supplied in the manure, which is a necessity to the crop. But when we possess the knowledge that a certain crop requires an excess of some one constituent, it will greatly assist both crop and soil if we add it in addition to the manure. For instance, the ash of Potato contains 63 per cent. of potash and soda; the ash of Wheat contains only 31 per cent. of these. But on the other hand the ash of Wheat contains 46 per cent. of phosphoric acid, and that of the Potato only 18 per cent. Now it is not difficult to see that the same amount of potash and phosphoric acid applied to fields where it was intended to grow these two crops side by side must result in a loss, for if we applied the greater amount of each in both cases the manure would be wasted, and if we applied only the smaller quantity the crops would suffer.

A few words now as to how we can improve the soil. If there were no decay there would be no growth, for it is decay of matter in the soil which supplies food to the plant. Our object, then, must be to bring the and into such a state that the manures and other matters which we put

into it may undergo those changes which turn them into plant food. If we wished to cause a piece of wood or other vegetable matter to decay as quickly as possible, what should we do with it? I should say place it in a position where air and moisture could both get to it. It has been proved by experiment that decay is most rapid where air and water meet. A bar of iron placed upright in a tub of water for some time will be found to rust away most rapidly just at the part which is nearest to the surface of the water. Take a beam of wood, build it into a house, keep it properly dry, and it will last for hundreds of years. Take the same beam, bury it deep in a bog, deep in water but preserved from air, and again it will keep sound for centuries. Only the other day we read in the newspapers of the finding of the framework of an ancient ship, probably eight or nine hundred years old, in Lincolnshire; it was discovered during the excavating for a gas-holder deep in the ground, and the wood was perfectly sound. Not very long ago I stood in a natural forest high up among mountains, where great trees, probably 8 or 10 feet in diameter, being blown down by the gales, decay and fall away to earthy matter in about four or five years, so wet is the climate, while the same trees down in the valleys, some 3000 feet below, I believe, stand sound and strong, the wood becoming like iron, for thirty or forty years after the settler has killed them.

(To be continued.)

### FRUIT EXHIBITION AT THE CHILWELL NURSERIES.

NUMBERS of visitors are attracted to these nurseries to inspect the fine display of Apples and Pears, and £10 being offered in prizes brought a good number of exhibits. The Show is held in a spacious vinery 100 feet in length; 310 dishes are very neatly arranged on a table down the middle of the house. The collection of twelve varieties, culinary Apples (six fruits each) brought seven exhibits. Mr. S. Rhodes, Thurgarton Park, Notts, was first with good fruits, the most conspicuous being Maltster, exceptionally fine, New Northern Greening, Spencer's Favourite (Queen Caroline), Caldwell, Emperor Alexander, Normanton Wonder, Warner's King, and Blenheim Pippin. Second, Mr. J. Jones, gardener to the Hon. Louis Hope, The Knowle, Haylewood, Derby, showing a splendid dish of New Hawthornden. Equal second Mr. F. Oldham, gardener to C. Schwind, Esq., Broomfield Hall, Derby. With dessert Apples there were ten exhibits of six dishes. First, Mr. Anderton, gardener to H. R. Clifton, Esq., Clifton Hall, Notts, showing in good condition Lord Lennox, Blenheim Pippin, Cox's Orange Pippin, King of the Pippins, New Bess Pool, and Ribston Pippin, all well grown. Mr. F. Oldham was a close second with King of the Pippins, Golden Reinette, Cox's Orange Pippin, Worcester Pearmain, Blenheim Pippin, and Eve. Third, Mr. Attenborough, gardener to W. H. Farmer, Esq., Alexander Park, Nottingham. With twelve dishes of Pears, distinct, there were five entries. First, Mr. Cunningham, gardener to J. Marriot, Esq., The Elms, Crosswell, Rubley, Notts.—viz., Beurré Hardy, Glou Morceau, Beurré Rance, Uvedale's St. Germain, Urbaniste, Doyenné du Comice, Marie Louise, Durondeau (very fine), Doyenné Boussoch, Marchal de Cour, Beurré Sterckmans, and Beurré Diel. Second, Mr. Marks, gardener to C. R. P. Morewood, Esq., Alfreton Hall, Derby. Third, Mr. Oldham. In the class for six varieties—first, Mr. Anderson; second, Mr. Attenborough; third, Mr. Coy, gardener to Rev. Drooston, Bingham Notts. For the heaviest Apple there were five entries, the first prize going to Mr. Rhodes with a Malster, weighing 12½ ozs. An extra prize in this class was awarded to Mr. Anderson for a beautiful fruit of Blenheim Pippin. For the best dish of Pears Mr. Cunningham was first with a grand dish of Beurré Diel, and Mr. Milner extra for an exceptionally fine dish of Winter Nelis. Mr. Toulson of Chilwell, exhibited, not for competition, a fine Warner's King, weighing 20½ ozs., also dishes of New Northern Greening, Court Pendu Plat, and King of the Pippins in good form.

Mr. Ingram, of Belvoir Castle Gardens, showed a very fine sample of a new Potato, Ideal, and Mr. Taylor, of King's Newton, a very promising late culinary Apple, which he intends to name Newton Wonder. Among the varieties selected from Messrs. J. & R. Pearson's own orchards were noticeable Golden Reinette, Cellini, Warner's King, Spencer's Favourite, Beauty of Kent, Pott's Seedling, New Northern Greening, and Duchess of Oldenburg, the latter still sound, though ripe in September. Blenheim Pippin was included in every collection, and was very fine throughout both in size and colour. New Northern Greening was well represented. Mr. R. Milner exhibited in three classes, but as the competition was confined to Notts, Derby, Lincoln, Stafford, or north of these counties he was disqualified from showing against the other exhibitors, but owing to the exceptional quality of his fruit he was awarded an extra first for twelve varieties of Pears, and an extra second for dessert Apples.

### MEMORIES OF A TOUR.

(Continued from page 405.)

#### THE CASTLE COCH VINEYARD.

I WAS brought to a sudden stop last week just when entering on a description of this interesting example of Grape-growing in an open field as a commercial undertaking in the production of wine. In order to make as clear as possible the method of growing the Vines, I had a photograph of one of them sent to an engraver some time ago, and subsequently sent a written request to be furnished with the engraving of this Vine. It seems the artist had at the same time the view of a celebrated garden in hand, and so when I asked for the Vine he sent me the "view," and as there was no time to rectify the error I had to pull up sharp. The Vine now appears, and the view will no doubt follow in due course. Both of them afford sufficient evidence that my talented coadjutor can do his work better than I do mine, for I must attribute the mistake to my faulty calligraphy, of which I am often not a little

ashamed. However, I managed to write "Vine" plain enough the second time, and had my reward. This reminds me of a delicate compliment bestowed by a celebrated gardener to whom I had occasion to write some time ago, and who replied, "I have received your letter, but can only read some of it, as the style is so distinguished." I thought that admirable, and the more so since my friend's "style" of writing was so far beyond me, that I have not to this day been able to decipher anything like the whole of his letter, so we both stand "distinguished" for bad writing. This is mentioned in the hope that young gardeners who are desirous of entering the literary arena may take a lesson from our shortcomings, and distinguish themselves in a directly opposite manner. And now having stated what "happened" to check progress, we will glance at the vineyard, and see if what has been done there does not afford material for reflection.

As was recently intimated in the review of Mr. Barron's excellent work on the Vine, the author remarked that, "the Castle Coch experiment of growing Grapes in an open vineyard is not considered to be very successful." There was sufficient justification for the observation at the time it was penned in 1883, but there have been many changes since then, and amongst them the most important have been better and brighter summers than those shortly anterior to that date. The Vines were planted in 1875, and in 1877 yielded forty gallons of wine, which, at the price now obtained for the "Castle Coch" brand, would be worth £60, or £30 an acre; but the Vines were young then, and more wine was obtained in the following year. Then came the not to be forgotten season of 1879, when the Potato and grain harvests were failures through excessive wet, and many of the Grapes dropped off the Vines. This meant another year's failure, for the wood was of necessity soft and unfruitful. There was a good crop in 1881, then two more failures through bad seasons, so that Mr. Barron was quite right, for up to 1883 the experiment was certainly not very successful. If we take the first ten years probably the value of the wine made would not much more than pay expenses, yet there would presumably be no loss. The weather during the greater part of that period caused other fruit crops to fail, and the Vines had to endure an ordeal of exceptional and abnormal severity. But what do we find since then? Not prosperity in agriculture, nor in ordinary fruit culture in this country; but taking the wine value of this year's vintage alone, we have at its actual selling price of £3 a dozen a total of £840, the yield, Dr. Hogg tells me—and he has seen the must, or new wine, since I saw the Vines—being 10 hogsheads. If we spread that over twelve years we have an average of £70 a year, or £35 an acre, two acres being under cultivation. Can ordinary fruit culture or farm crops show an equal result? for that is a fair way of testing the matter; and judging by that test, the Marquis of Bute is surely not adopting a reckless policy in extending his vineyards very considerably. The experiments now may fairly be considered satisfactory, and there is at least as bright a future for wine-growing in South Wales as for any other crop that is ordinarily grown in this country. Eleven more acres are to be planted, making a total of thirteen, or 62,920 Vines.

The vineyard at Castle Coch is favourably situated both as to site and soil. The soil is yellowish loam of a medium texture resting on broken limestone. It was trenched 2 feet deep, and the turf turned in gave it a fibry texture. There is thus a good feeding ground and good drainage. It slopes to the south from the base of a high and heavily wooded hill, thus is well sheltered from the north; it is also fairly protected from the east and west by lower and less heavily wooded hills from a quarter to half a mile away. The Vines are growing 3 feet apart in lines from north to south, with the same distance between the plants, or one to each superficial yard, making 4840 to the acre. They are secured to strong stakes cut from the wood, such as are commonly used for Raspberries, and rise about 4 feet above the ground. As viewed from either end, looking up the slope from the south side, or down it from the north, the straight rows of Vines, neatly dressed, no laterals bristling from them, the ground clean, and the Grapes changing, it was impossible not to admire the general effect, and particularly the remarkable health of the Vines and the care with which they were tended. Mr. Pettigrew's trusted helper practically lived amongst these Vines, and had his little lodge for shelter. He knew where the best bunches were, and pointed them out with modest pride and a politeness of manner that is not equally possessed by all tillers of the ground. His appeared to be a pleasant occupation, and he carried out intelligently the wishes of his chief. This active and experienced Vine dresser, though not old, had passed the meridian of life, and has since been summoned to his long rest, leaving a good name behind him.

Most persons, I apprehend, who are expecting to see something for the first time form an imaginative sketch of the object. In my forecast of the Vines at Castle Coch I was at fault in one particular. I was under the impression they were managed the same as Raspberry canes are—that is, taking two or three up a stake, bearing them their entire length, then cutting them down in winter; others, of the summer's growth, being trained in their stead. That is simple enough, but the method adopted with the Vines in question is simpler still. It consists in cutting back the bearing canes every year close to the main stem or stump 9 inches or so from the ground. The stem naturally enlarges, just as a spur does on the main rod of a Vine under glass. The Vines then may be said to be cut back to the spur every season, exactly the same as "pollarding" Willows. Several buds break, and growths start in the spring, just as they do from spurs in a vinery. Disbudding is then resorted to, and a selection of the most promising growths made for bearing. In the engraving three are shown, a leaf or two having been



removed to render them more visible. The bunches are produced from the second, third, or fourth joints from the base, but under glass the bearing laterals are topped, or as we commonly say "stopped," at the first, second, or third leaf beyond the bunch, according to the space between the rods; but in the open air there is no limit to the space upwards, and the growths, which correspond to the laterals in vineries, are allowed to reach the top of the stakes and are then topped, it may be at seven or eight leaves beyond the bunch. The secondary growths or sub-laterals are suppressed as fast as produced, this pinching and hoeing the ground to prevent weeds being all that needs to be done in the summer. The ground is not dug, but is firm, and "netted" with roots, and a dressing of Thomson's manure has been, if I remember rightly, once applied. *WOLSCOT.*

The health of the Vines is of the best that can be imagined, as indicated by the sturdy growth of the canes and the extraordinary texture of the foliage. Consequent on the short-jointed growth the crop is clustered towards the base and not far from the ground; and it is



Fig. 53.—A Castle Coch Vine.

possible that it ripens the better on that account through the radiation of heat from the earth. The leaves of the Vines are not quite so large as those of well-grown Black Hamburgs under glass, but equal the best of them in substance, far surpassing the majority in that respect; and it would not perhaps be easy to find examples under glass equalling in weight the best grown in this open vineyard. It is not the mere size or superficial area of leaves that represents their value, but texture or weight in accordance with size, or, in other words, a Vine leaf 9 or 10 inches in diameter may be better, because stouter and heavier, than one a foot or more across. When Vine leaves are abnormally large, and at the same time thin in texture, soft and flimsy, it is a certain indication of imperfect growth, and indubitable evidence of something being wrong somewhere. That there was nothing wrong with the Castle Coch Vines, or at least with the variety best adapted for the purpose in view, and which is the most extensively grown, was apparent, and I have not the remotest fear of anyone who inspected them in September, and who is competent to judge on the matter, questioning their superior con-

dition. In that respect they quite exceeded my expectations, and I was more than satisfied with my visit to this vineyard when the Grapes were ripening for the best vintage that has been seen in England in the memory of man. Whether the monks of old had better from their vineyards we shall never know, but if they grew their own wine in various parts of the country—and for what other purpose could the vineyards be established?—why cannot it be produced in other districts than South Wales now? The rainfall is less in many parts, and equally good shelter could be found, such as in clearances that might be made in unproductive woods and plantations. If I were in the position of many landed proprietors I should certainly try what could be done, and should not expect to fail. But it has to be remembered that wine-growing involves waiting for results, these now attained at Castle Coch being represented by 60s. per dozen for the rich, yet vinous, Sauterne-like wine that is there produced through all stages, from inserting the cuttings of the Vines, pressing out the juice from the Grapes, and maturing and bottling the wine by Mr. Pettigrew. The demand for this wine exceeds the supply, the Marquis of Bute is satisfied, and his gardener ought to be proud of his work.

Much more could be written on this interesting subject, but Chrysanthemums are in the ascendant just now, show reports claiming space, and it can only be added that the ordinary early Sweetwater and Muscadine Grapes are of no use for wine-making in comparison with the variety chiefly planted by Mr. Pettigrew—the Gammy Noir. The bunches are not thinned, the Grapes, being small and blue-black in colour when ripe; but it is not necessary that Grapes should be dead ripe for wine-making.

We returned from Castle Coch *via* Llandaff, a neat, well-to-do-looking village-like city of apparently three or four hundred inhabitants, glanced at the beautiful tower of the restored cathedral, peered through the trees at the Bishop's palace, and a two-miles drive, mainly through an avenue of young trees planted by Mr. Pettigrew, took us to his house again, from which we soon afterwards departed, with pleasant remembrances of unbounded kindness, for Margam.—A TOURIST.

\* \* The figure 2 appears to have dropped out of the type on page 40 last week, making the Recreation Ground at Cardiff 4 instead of 24 acres.

#### GROS COLMAN GRAPES NOT COLOURING.

I SHOULD be glad if some of your able correspondents could inform me why this Grape has not ripened with me. This is the first time I have grown it. The vinery was started on January 15th at 45°, the heat was gradually increased until it reached 65° during the flowering period—night temperature—the day being 10° or 15° higher, according to the weather. The Vines all broke strongly and regularly, and all finished their crop beautifully, except Gros Colman. The Vine is not heavily cropped, having but eleven bunches of medium size. The Vines were planted in 1884. What crops they carried previous to last year I do not know, but when I took charge, a little more than a year ago, every Vine from which the fruit was not cut had twenty-four bunches on, some of them very large. I thought the crop too heavy, so allowed none of the Vines this year to carry more than twelve bunches, and so give them a chance to recoup themselves this year. Would the heavy crop of last year affect the ripening this year? A clever piece of workmanship on the part of my predecessor was to plant the early vinery with Black Hamburgs, Gros Colman, Muscat of Alexandria, and Buckland Sweetwater, while the late house in which the Grapes are required for Christmas is planted with Alicante, Lady Downe's, Mrs. Pince, and Black Hamburg. Is it too late for me to shift the Gros Colmans and Muscat of Alexandrias into the late house, and bring the Black Hamburgs into the early vinery? I must start the early vinery in January, and the late one in March. I would not mind having to sacrifice a crop next year on the Black Hamburg that I want to move if I could secure a few bunches off the Muscats and Gros Colman in the late house. The vineries are span-roofed, and contain six Vines on each side. The soil is sandy loam, the top spit from the deer park. It contains no lime, and as far as I can ascertain no lime rubbish was used in making the borders. The Vines have had plenty of water and liquid manure from the farm yard, also two dressings in spring of half inch bones. I may add, the last of the Grapes in the early vinery—with the exception of Gros Colman—were cut a fortnight ago, the crop having given entire satisfaction to my employer in all points. I enclose sample of Grapes in question for the Editor's opinion. They are deficient in stones (also flavour) as they were never fertilised beyond tapping the rods.—A YOUNG HEAD GARDENER.

[The Vines may be removed and replanted at once, due care being exercised in the work, and the leaves retained as long as possible. The Gros Colman Vine was weakened by overcropping last year, and this year's crop, though much lighter, was still too heavy. The Grapes are of good size, but the skins too thin and tender for long keeping.]

#### ROYAL HORTICULTURAL SOCIETY.

NOVEMBER 8TH.

SCIENTIFIC COMMITTEE.—Present: G. F. Wilson, Esq., F.R.S., in the chair; Messrs. Lynch, Smith, O'Brien, Smece, Michael, MacLachlan, Pascoe, Bidley, Murray, Professor Church, Professor Ward, and Rev. G. Henslow.

*Eryngium Species as Bee-flowers.*—With reference to Mr. Wilson's observations on *E. giganteum* being a good bee-flower, Mr. Henslow

remarked that a bee-keeper in North Wales had ascertained that *E. maritimum* was also a good plant. Observations were made upon honey scented by particular flowers, Mr. MacLachlan remarking that Lime gave a remarkable flavour to it at Blackheath. Mr. Smee added that the honey from near Mitcham was so strongly flavoured by Peppermint as to be uneatable. Professor Church called attention to the fact that many specimens of "scented honey" had long been in the Bethnal Green Museum, obtained by placing the hives near to particular plants. He believed they came from Russia.

**New Method of Glazing.**—Mr. Smee reported upon the specimen sent by Messrs Newton to the last meeting, and corroborated the impressions then expressed; especially with reference to the allowing for due expansion and contraction.

**Weevil in Orchids.**—Mr. Paseoe exhibited a specimen of *Baris eburifera* found on *Vanda teres*, and requested that all such discoveries of foreign insects might be sent to him.

**Frost and Trees.**—Professor H. Marshall Ward drew attention to the fact that several notices had lately been made upon the injuring which trees sustained when growing on a south sloping bank; but that it had long been noticed and recorded by Gilbert White. The interpretation is that the roots are stimulated by the warmth due to the position, so that the proper ripening of wood does not follow before frosts set in.

**Cladosporium fulvum.**—Mr. W. G. Smith brought, and Mr. Plowright of Lynn sent specimens of this fungus on Tomatoes. The latter forwarded the following communication:—"I herewith send specimens of *Cladosporium fulvum* on the fruit, leaves, and stems of Tomato. I have had them in my possession for six weeks, and the Tomatoes have turned red, so that the zone of green colour which surrounds the fungus in its earlier stages, while the Tomato is changing colour, has disappeared. This maintenance of colour in and around the parasite is found with several of the Uredines, and is due to the presence of the mycelium of the fungus causing delay in the normal processes of maturation of the host plant's tissues."

**Dilophosporium graminis.**—Mr. Plowright also added the following remarks upon this parasite:—"I stated in the *Gardeners' Chronicle* last week that this plant had not been found in this country as a parasite upon Wheat. This is an error, for I find that Mr. Berkeley, in the 'Annals of Natural History,' in 1865, mentions that a crop of Wheat was seriously injured by it in Sussex in 1862. Mr. F. Currey found it on *Alopecurus agrestis*."

**Monstrous Flowers, &c.**—Mr. Smee exhibited two flowers of *Vanda cœrulea*, with the dorsal sepal aborted, in one case, and drawn out to a slender stalk with a cup-like extremity in the other. Bulrushes, with two and three "heads" to them; also a *Chrysanthemum* of the Anemone-flowered type, with supernumerary heads below the ray, or "hen and chickens" variety.

**Solanum corniculatum.**—Mr. Ridley exhibited the curious orange-coloured fruit of this plant; it is about the size of a hen's egg with four or five horns proceeding from the base. They are protrusions, the central tissue of which is common with that of the mesocarp of the fruit. It is an introduced plant, and used for liver complaints in Fernando Noronha.

**Cactus species.**—This, like the preceding, was brought from Fernando Noronha, but it is endemic. It had large oval crimson fruits, scented and edible. The flowers only expanded at about 10 P.M.

**Erythrina species.**—He also showed a drawing of a native tree in blossom. It is the only one left, as all the large trees are cut down lest the convicts should make rafts.

**Croci.**—Mr. Lynch exhibited the following autumn flowering species from the Botanic Garden at Cambridge:—*C. Pallasi*, *Tingitanus*, *Tourneforti medius*, *canecllatus var. cilicium*, and *longiflorus*.

**Lilium polyphyllum.**—Mr. G. F. Wilson exhibited a stem grown at Wisley to show the difference between the cultivated form, which had thirteen blossoms, and the wild one bearing only four to six. He stated that a Dutch missionary, a friend of Mr. Hufklen of New York, describes *L. polyphyllum* in its own country (the Nilgiris) as a very handsome Lily 5 or 6 feet high, with from four to six flowers on a stalk 5 feet 5 inches. Mr. Gamble has seen it on the hills about Simla, but has never seen wild any so big as we describe.

**Carbonised Coquilla Nut (Attalea funifera).**—He also exhibited nuts or fruits of this Palm, well known for turnery purposes, which had been dug up in the city. The three internal septa and the ovary walls were completely changed to coal. It had doubtless been formed under great pressure. Similar results had been found after the great fire in Tooley Street. Professor Church remarked upon the remarkable hardness of the Cocoa-nut, which, as charcoal, had an extraordinary power of absorbing gases.

**Mandevilla suaveolens.**—The Hon. and Rev. Boscawen sent fruit pods of this apogynaceous plant, which are not often seen in this country, though Mr. Lynch said they found it at Cambridge. In the "Botanical Register," 25, 7, it is described as flowering in conservatories, but not fruiting.

## CHRYSANTHEMUM SHOWS.

PORTSMOUTH.—NOVEMBER 10TH AND 11TH.

The new Drill Hall, Landport, in which the Exhibition under notice was held, is a building of unusual size. So large is it that vans can be drawn between the tables and their contents deposited at any desired point, and if fifty vehicles were under the roof at once the whole of the available

space would not be occupied. This is a great convenience to exhibitors, and the wide promenades between the tables is convenient in another respect, for we are informed that upwards of 8000 visitors entered the Show in three hours—namely, from six to nine o'clock on the evening of the second day at 1d. each for admission. The Show was also of great magnitude and merit—a striking advance on the Exhibition of last year. The groups were numerous and effective, some of the collections of specimen plants splendid, and the cut blooms, of which 2000 were staged, were most creditable to the several exhibitors. There was great and close competition in most of the classes, and the work of judging was no light task.

**Cut Blooms.**—The principal class was that for thirty-six blooms, distinct varieties, eighteen incurved and the same number of Japanese, the chief prize being the challenge vase, value £25, and £6 in cash; second prize £5; third, £2 10s. For these eight collections were staged, making a very fine display. It will be remembered that Mr. E. Molyneux, gardener to W. H. Myers, Esq., Swanmore Park, Bishops Waltham, succeeded in winning the first prize last year, the conditions being that should the same exhibitor win the vase twice (not necessarily consecutively) it should become his property. Much interest was attached to the present year's contest, as it was thought the high and dry hill of Swanmore during the tropical summer would not be favourable to the development of superior blooms, and Mr. Molyneux might have to relinquish possession of the vase. His blooms were not so large as we have seen them, but they were quite large enough for the occasion, also bright, and beautifully finished, winning with comparative ease as respects the incurved, though there were strong stands against them. The Japanese were not so large as some others, but remarkably fresh, the whites pure and the remainder rich and clear in colour. The former, however, won him the position, and were the best incurved blooms we have seen this season. He has now won three great challenge cups in six consecutive years, and none of his competitors will question the justice of the awards. The following are the varieties staged at Portsmouth:—

**Incurved.**—Back row—Alfred Salter, Golden Empress, Empress of India, Golden Queen of England, Lord Alcester, and Queen of England. Middle row—John Salter, Lady Hardinge, Empress Eugénie, Jeanne d'Arc, Lord Wolseley, and Princess of Wales. Front row—Mrs. Heales, Prince Alfred Barbars, Hero of Stoke Newington, Princess Teck, and Lady Carey.

**Japanese.**—Back row—Madame C. Audiguier, Meg Merrilies, M. Délaux, Fair Maid of Guernsey, Baronne de Prailley, and Ralph Brocklebank. Middle row—Criterion, Madame Lang, Thunberg, Val d'Antorre, Avalanche (fine), and Triomphe de la Rue des Châlets. Front row—Belle Paule, Soliel Levant, Edwin Molyneux (rich), Mille Lacroix, Martha Hardinge, and Jeanne Délaux. Messrs. W. & G. Drover, nurserymen, Fareham, were placed second, the Japanese blooms in this stand being heavy and good, but there was a falling off in the incurved blooms, though they were far from inferior. Mr. R. Woodfine, gardener to Captain Boyd, Emsworth House, Emsworth, Havant, was a close third with fresh but smaller examples and meritorious. A fourth prize was worthily awarded to Mr. W. Neville, gardener to F. W. Flight, Esq., Cornstiles, Twyford, Winchester, Mr. J. Wright and the new Miss Flight being attractively staged.

For two Japanese blooms, distinct varieties, there were seventeen entries, the best coming from Mr. Woodfine, these being large, rich in colour and fresh, Jeanne Délaux, Thunberg, and Belle Paule being the best. Messrs. Drover occupied the second position, while Mr. Molyneux took third honours. For twelve incurved blooms, distinct, there was a strong and close competition of twelve stands, Mr. Molyneux leading with fresh, full, solid blooms. Messrs. Drover were second, and Mr. Woodfine third, both staging well. Ten competed for twelve reflexed, not less than eight varieties. Messrs. Drover were first with full deep specimens of Cul ingfordi, Amy Furre, Peach Christine, and C. of Gold. Mr. Russell, gardener to Dr. C. F. Lewis, Henfield, Sussex, was second with medium-sized full blooms, Mr. Neville third. Mr. Russell gained the highest honours for the same number of Anemone blooms, Mr. Woodfine being second, and Mr. Penford, gardener to Sir F. Fitzwygram, Bart., Leigh Park, Havant, third. For six Japanese Anemones, three varieties, Messrs. Drover scored first honours, Fabian de Mediana and Mille Cabrol being very fine, Mr. Penford second. The best Pompons were staged by Mr. Russell, closely followed by Mr. E. Garnett, gardener to Captain Arbuthnot. Messrs. W. Wood & Sons, Wood Green, London, offered their Jubilee silver medal with a money prize for eighteen cut blooms, six to be Japanese, six incurved, and six reflexed, the plants to have been fed with their "liquid manure powder," Mr. Molyneux was an easy first, staging grand incurved, fine Japanese, and good reflexed specimens, Messrs. Drover second. For twelve incurved blooms, distinct, amateurs only, the Rev. J. Wells, Havant, was an easy winner, showing a capital lot; notable in this lot was a magnificent specimen of Lord Alcester, which was awarded the premier prize as the best bloom incurved in the Show. The premier Japanese was Avalanche in Mr. Molyneux's stand, a pure white bloom, extra deep and solid, a new kind but little known. A beautiful stand of single varieties, arranged in bunches of three, was staged by Mr. Molyneux, "not for competition," to which an extra prize was given, so meritorious were they considered. Many prizes were offered to growers living in Portsea Island only, and amateurs, the competition being keen, and the quality as a whole excellent. Mr. Molyneux took first honours for the best two blooms, one Japanese and one incurved, to be shown in separate classes with fine specimens of Madame C. Audiguier and Lord Alcester; second Mr. Roberts, gardener to E. R. Longcroft, Esq., Havant.

**PLANTS.**—A special inducement was offered for these in the form of a Jubilee first prize of £10 for the best eight specimens, four incurved and reflexed, and four Japanese. Six competitors entered the lists, and the magnificent specimens justified the offering of such a prize. The best plants came from the neighbourhood of Southampton. Mr. Wakeford, gardener to G. Harris, Esq., Alder Moor, Shirley, was accredited chief honour for very fine specimens, some of them measuring 5 feet in diameter, neatly trained, with good foliage, and profusely flowered, Fair Maid of Guernsey, Peter the Great, Mrs. Sharpe, and Peach Christine being extra good. Mr. E. Wills, gardener to Mrs. Pearce, Firs, Bassett, Southampton, was placed second with some very fine plants, but in justice to this exhibitor it should be said that some evil disposed person, on the night of November the 5th, wilfully cut and destroyed many of his finest specimens—a most dastardly act. Mr. A. Smith, gardener to Mrs. Learmouth, Havant, was a



distant third. Another class was provided for the same number of plants, four to be Japanese, and the same number to be either incurved or reflexed. Mr. Will's took first honours with large neatly trained specimens freely flowered. Mr. G. Lambert was second, and Mr. Penford third. The best single specimen, any variety, was staged by Mr. Willa, a very fine one of Dr. Sharpe, second Mr. Penford. For the best group of Chrysanthemums in a space of 50 feet, eleven competed. Mr. Hatch, gardener to the Victoria Park Committee secured leading honours with an effective arrangement mainly composed of Japanese varieties carrying fine flowers and good foliage. Second Mr. C. H. Kingswell, gardener to Admiral Hopkins, The Dockyard, Portsmouth; third Mr. Roberts. Specimen Pompons were of moderate quality only. Table plants and Solanums were best staged by Mr. Molyneux and Mr. Penford.

Fruit was not staged in large quantities, but the quality was good, particularly the black Grapes from Mr. Molyneux, who took first honours for two bunches of black with Alicante finely coloured and of good size. Mr. E. Smith was second, showing the same variety, but smaller. The same exhibitors showed the heaviest bunches, that from Mr. Molyneux being 9 lbs. 12 oz., a shapely bunch of Groa Guillaume; that from Mr. Smith being Alicante, smaller. Mr. J. Chalk, gardener to G. Read, Esq., Salisbury, was first with two bunches of white Grapes, with medium-sized, well finished examples of Muscat of Alexandria; Mr. J. Covell, gardener to J. A. Martin, Esq., being second with the same variety.

Vegetables were staged in goodly numbers. For a collection of eight distinct kinds, Mr. Molyneux was first with Veitch's Autumn Cauliflowers, Brussels Sprouts, Tomatoes, and Leeks being the most noteworthy; Mr. Penford was second, staging good produce. Other classes were well filled with choice kinds.

So great was the crowds of people visiting the Show, that barriers had to be placed in front of the cup blooms, and a policeman had to be stationed at that point to keep the people moving: 14,133 persons visited the Exhibition during both days, the amount taken at the doors being £165—namely, £92 at 6d. each, £40 at 3d., and £33 in penny admissions. So much for popular prices in a populous district. Much credit is due to Mr. F. Power, the courteous and indefatigable Honorary Secretary, for the excellent arrangements made both for exhibitors and the public, ably assisted by Messrs. Barnes, Ellis, Hatch, and Collins, members of the Committee, the latter directing the staging of the exhibits. Under such efficient management the Portsmouth Chrysanthemum Society is sure to prosper, and its exhibitions are probably destined to take a very high rank in the floral world.

#### BRIXTON.—NOVEMBER 10TH.

The annual Exhibition of the Brixton and District Horticultural Society is invariably a model in the even quality of the exhibits and the excellence of arrangement, but this year the want of adequate space was felt more keenly than ever. The courteous and experienced Secretary, Mr. W. Hall, however, disposed the exhibits most tastefully, and the general opinion was that it was the best Show the Society has had.

The Show of the present season was held in the lecture hall, Congregational Church, Streatham Hill, on November 10th. The building is of moderate size, and is provided with a gallery, from which the cut blooms and specimen plants arranged in the body of the hall can be seen to great advantage.

A long table ran along the middle of the hall, large specimen pyramidal Chrysanthemums clothed in bloom being arranged along it in the centre, with Primulas immediately in front of them on one side and Ferns on the other. Stands of cut blooms occupied the remaining portion of the tables, which were thus most attractively furnished. The platform at the upper end was occupied with Tree Ferns, specimen Chrysanthemums, stove and greenhouse plants, and Orchids, and also looked well. Other specimen plants were arranged at the sides of the hall.

The schedule embraced thirty-eight classes, while several special prizes were also offered. The following were the awards:—

**SPECIMEN PLANTS.**—Mr. E. Cherry, gardener to Mrs. Gabriel, Streatham, secured the first prize for six plants of large-flowered varieties, having well-bloomed examples of Dr. Sharpe, Mrs. Dixon, John Salter, Mrs. Halliburton, Lord Alcester, and Barbara, Mr. J. Weston, gardener to Mr. D. Martineau, Clapham Road, being second with good specimens, and Mr. W. Clarke, gardener to Mr. J. H. Lile, Brixton Hill, third. Mr. Weston won with six Pompons, having large profusely flowered plants, amongst which Golden Cedo Nulli and White Cedo Nulli were conspicuous. Mr. Cherry followed with smaller but healthy plants, Mr. Luff, gardener to Mr. R. B. Hyatt, bringing up the rear with a meritorious batch. Pyramid Pompons were best shown by Mr. Luff, his collection including fine examples of Sœur Melaine and Calliope. Mr. Livermore, gardener to Mr. F. Webb, Christ Church Road, was second; he had La Sultaine large and profusely bloomed, but other plants were weak. Mr. Cherry was third. Mr. R. Clarke, gardener to Mr. Griffiths, Streatham, showed well in the class for three plants of large varieties, having Lord Alcester, Mrs. G. Rundle, and King of Crimson in excellent condition. These easily accounted for first prize; Mr. W. Clarke and Mr. Cherry following in close order. In minor classes for Pompons, Messrs. Weston, Cherry, W. & R. Clarke, Livermore, Luff, and Howes, gardener to Mrs. F. Bennett, Upper Tulse Hill, were most successful. Mr. Sadler, gardener to Mrs. Lambert, Streatham, took first place in a class for twelve Japanese for prizes given by the President, Mr. T. Gabriel; Mr. Howes followed, third prize going to Mr. Luff.

**CUT BLOOMS.**—The leading incurved class was that for twenty-four distinct varieties, and the premier award fell to Mr. C. J. Salter, gardener to Mr. J. Southgate. He had exceedingly bright and fresh blooms, the majority of good size. The varieties were as follows:—Back row—Lord Alcester, Prince Alfred, Princess of Wales, Alfred Salter, Empress of India, Prince of Wales, Golden Empress, and Queen of England. Middle row—Lady Hardinge, Jeanne d'Arc, Lord Wolseley, Beverley, John Salter, Mrs. Heale, Mr. Cobay, and Jardin des Plantes. Front row—Mr. Bunn, Bronze Jardin des Plantes, Barbara, Refulgence, Mrs. Dixon, George Glenny, Mrs. Shipman, and an unnamed variety. Mr. T. Sadler was a close second, and Mr. Luff third. Mr. Salter was to the fore with twelve solid even blooms. Mr. Howe, gardener to Mr. H. Tate, Streatham Common, was the next in

order of merit, making an excellent fight, and Mr. Sadler was third. Messrs. Salter, Howe, and Gibbons, gardener to Lady M. Pollock, Clapham, took the prizes for six blooms in the order named.

A first-rate stand of large Anemone-flowered took the first prize for Mr. Swain, gardener to Mr. E. Jones, Clapham Park, in the class for twelve of that section, the varieties represented being—Back row—Gluck, Minnie Chate, Lady Margaret, and Georges Sand; middle row—Sœur Dorothee Souille, Georges Sand, Acquisition, and Gluck; front row—Louis Bonamy, Prince of Anemones, Mrs. Pethers, and Sœur Dorothee Souille. Neat blooms from Mr. Livermore took the second prize, Mr. Gibbons accounting for the third. There was not much to choose between any of these; all were good. Mr. Livermore was first with Anemone Pompons, Mr. Gibbons following.

Japanese were finely shown in the class for twenty-four by Messrs. Mursell (gardener to Mrs. Burton, Streatham), Howe and Salter. The former showed Madame C. Audiguier, Fair Maid of Guernaey, Jeanne Délaux, Yellow Dragon, Madame P. Pigny, M. Freeman, Triomphe de la Rue dea Châlets, and Meg Merrilea in the front row; E. Molyneux, Ralph Brocklebank, Elaine, Val d'Andorre, Fernand Féral, Comte de Germiny, La Triomphante, and Boule d'Or, in the central row; and Mdlle. Moulise, Mrs. Townsend, Madame Féral, Mdlle. Lacroix, L'Adorable, Madame Laing, Marguerite Marouch, and Snowatorm, in the front row. These were large richly coloured blooms, and did great credit to the exhibitor. Mr. Howe's second prize stand comprised good examples of Criterion, Belle Panle, and Hiver Fleuri, amongst others, and Mr. Salter showed well for third place. Mr. Sadler's stand was very highly commended. Mr. Mursell was again to the front with twelve blooms. Mr. Salter followed closely, and Mr. Sadler was third. Mr. Howe won with six reflexed, a very neat stand, composed of King of Crimaons, Chevalier Domage, Distinction, Cullingfordi, Félicité, and Christine. Messrs. Sadler and Livermore were respectively second and third. In a maiden class for previous non-prizewinners Messrs. Plumb, gardener to Captain Grote, Clapham Common, and A. Moorcock, gardener to the Rev. S. N. Ranson, Streatham Park, were respectively first and second.

**ORCHIDS.**—For six Orchids, distinct, in bloom, Mr. Salter was placed first. He had well-flowered pieces of *Cypripedium Harrisianum*, *C. Spicerianum*, *Vanda cœrulea*, *Pleione lagaria*, *Odontoglossum Inaleayi*, and *Angræcum Kotschy*; Mr. Howe followed closely, with Mr. Luff third. For three plants Mr. Salter was again first, having *Cypripedium Harrisianum*, *Vanda cœrulea*, and *Cattleya Dowiana*; Mr. Luff was second and Mr. Howe third. Mr. Salter followed up his previous victories by winning with a specimen *Vanda cœrulea* with two fine spikes; Mr. Mursell was second and Mr. Fulbrook, gardener to Mr. B. B. Baker, Roupell Park, third.

A first class certificate was awarded to Mr. Salter for a fine mixed group of Orchids, and another to Mr. W. Hall for *Calanthe Halli*, the beautiful white-flowered hybrid recently certificated at South Kensington.

**STOVE AND GREENHOUSE PLANTS.**—Mr. Livermore occupied the post of honour with three plants—namely, *Epacris Model*, *Erica hyemalis*, and *Epiphyllum truncatum*, Messrs. Fulbrook and Gidner, gardeners to Major Saunders, Clapham Park, taking the remaining prizes. Messrs. Hill and Livermore were successful with single specimens.

Fine-foliage plants were best shown by Messrs. Luff, Cherry, H. Guyett (gardener to Mr. T. Gabriel, Streatham), and Howe; Ferns and Lycopods by Messrs. Luff, Wright (gardener to Mr. J. A. Whittard, Streatham Hill), Hill (gardener to Mr. G. W. Ryder), Ranson (gardener to Mr. J. T. Gabriel), and Fulbrook; Primulas by Messrs. Mursell, Ranson, and Salter (all very fine); table plants by Messrs. Luff, Guyatt, and Ranson; and Zonal Pelargoniums (Mr. Hyatt's special prize) by Messrs. Ranson, Mursell, and Luff.

**FRUIT AND VEGETABLES.**—Mr. Howe won with three dishes of dessert Pears, Messrs. Wright and Salter following. Mr. Guyett was first with kitchen Apples, and Mr. Sadler with dessert varieties; Mr. W. Collina, gardener to A. A. Flashto, Esq., also showing well. Some fine bunches of Grapes were shown. Mr. Howe was first with excellent bunches of Alicante and Mr. Salter with Muscat of Alexandria, a minor prize falling to Mr. Wing, gardener to Mr. W. Shepherd. Mr. Henry Tate's special prize fell to Mr. Howe, who exhibited some fine well-ripened examples.

Mr. Howe was a good first for a collection of vegetables, followed by Messrs. Hill and Vince. Special prizes, given by Mr. J. R. Box, Croydon, went to Messrs. A. Luff and Swan. Other prizewinners with vegetables were Messrs. Sadler, Wright, Salter, Howe, and Case.

#### LEWISHAM.—NOVEMBER 11TH AND 12TH.

The spacious public baths, near the South-Eastern Railway Company's station at Lady Well, Lewisham, were requisitioned by the Lewisham and District Floral Society for its Chrysanthemum Exhibition on November 11th and 12th. They were admirably suited for the purpose, the ground floor of the large bath affording ample space for the chief exhibits, those of a miscellaneous character being arranged in the smaller bath adjoining. Two rows of tabling provided space for the cut blooms in the larger compartment, while groups and specimen plants were arranged at the sides and end. The collective display was a highly attractive one, and the general arrangements of the Show reflected credit on the Management Committee and the energetic Secretary, Mr. Drake.

The schedule comprised sections for amateur members of the Society; others open to all comers, with substantial prizes; others for gentlemen's gardeners practising within a radius of three miles from the Lewisham Parish Church; and others for ladies, with several special awards.

**AMATEUR MEMBERS' CLASSES.**—Medals were offered for groups of plants, certificates and money prizes for specimens, and medals, certificates, and cash prizes for cut blooms.

**Groups.**—For the best groups of Chrysanthemums arranged in a space of not more than 50 square feet, quality and general effect to be the leading features, silver and bronze medals were offered, the chief award going to Mr. John Lock, 11, Wistaria Road, Lewisham, for bright, fresh plants, judiciously arranged. Mr. W. E. Jupp, Brockley, was second, his specimens bearing many fine blooms, but losing the first prize through carrying a number of dead flowers.

**Cut Blooms.**—Mr. G. Walker, Lingfield Road, Wimbledon, was the only exhibitor of twelve Japanese, and he received the chief award for a neat



stand, the varieties represented being L'Adorable, Val d'Andorre, Fair Maid of Guernsey, Criterion, Meg Merrilies, Belle Paulc, Flamme de Punch, Elaine, Fernand Féral, Mdle. Lacroix, and Jupiter. Mr. T. Wickham Jones, South Norwood, was to the front with six blooms, these being large, well-coloured examples of Mdle. Lacroix, Madame B. Rendatler, Triomphe de la Rue des Châlets, Marguerite Marrouch, Gloriosum, and Criterion. Mr. G. S. Addison, Thonon Heath, was a good second, and Mr. Walker third. This was a popular class, there being seven other stands in competition.

With twelve incurved, Mr. Frank Bingham, 6, Bethune Road, Stoke Newington, was to the front, and he had remarkably neat and even flowers. Mr. Walker followed. Mr. Bingham was again successful with six blooms. Mr. Wickham Jones took second place with fresh but small flowers, Mr. Addison bringing up the rear. There were six others competing.

Six Japanese, one variety, were best shown by Mr. D. B. Crane, 4, Woodview Terrace, Archway Road, Highgate, the variety being Val d'Andorre, and the examples good. Mr. H. Needs, 35, Ringstead Road, Catford, was second with Mdle. Lacroix, five others competing. Mr. Addison was the only exhibitor in the corresponding incurved class, and he was awarded the first prize for fresh examples of Mr. Bunn. Six Japanese Anemones were also represented by but one grower, and here the first prize went to Mr. Wickham Jones for a capital stand.

Further prizes for Japanese and incurved were won by Messrs. Walker, Addison, E. B. Douet (11, Carlton Road, St. John's), Humphry (42, Popc Road, Bromley), and Wickham Jones. The premier incurved bloom in the Show was Angelina in Mr. Frank Bingham's first prize stand of twelve. The prize was a silver medal, and the winning flower was of good size, symmetrical, substantial, and fresh.

**OPEN CLASSES.**—These comprised cut flowers only. Three prizes, value £5, £2, and £1, were offered for forty-eight blooms—twenty-four Japanese, and twenty-four incurved, not less than eighteen distinct varieties in each. Mr. Shoosmith, gardener to the Rev. Canon Hodgson, Saltwood Rectory, Hythe, easily won the first prize. The majority of his blooms were large and well finished. The varieties represented were as follows:—Japanese: Meg Merrilies (2), Sol il Levant, Val d'Andorre, Mdle. Lacroix, Boule d'Or, Madame Audiguier, and Carew Underwood in the back row; Carew Underwood, Madame John Laing (2), Boule d'Or, Jeanne Délaux, Triomphe de la Rue des Châlets, La Triomphante, and Thunberg, in the middle row; Thunberg, Japonaise, Fair Maid of Guernsey, L'Adorable (2), Mrs. W. Harris, Roi des Japonaises, and M. Astorg, at the front. The incurved varieties, which were particularly good, were—back row: Queen of England, Lord Alcester (2), Empress of India (2), Alfred Salter, Golden Empress, and John Salter; middle row: Hero of Stoke Newington, Jeanne d'Arc, Mrs. N. Davis, Mrs. Heale, Golden Empress, Princess of Wales (2), and Mrs. Shipman; front row: Mrs. Dixon, Lord Wolseley, Princess of Teck (2), Cherub, Sir Stafford Carey, G. Glenny, and Barbara. Mr. J. Staines, gardener to Mr. J. Newton, J.P., Park Hill, Croydon, was second. His Japanese were good on the whole, but several of the incurved blooms were weak. Mr. Pascoe, gardener to Captain Torrens, Hayes, was a close third. Mr. W. Packman, gardener to Mr. C. E. Shea, The Elms, Foot's Cray, had an excellent stand of twelve Japanese, and won easily; Messrs. Moore, gardener to Mr. W. C. Pickersgill, Blurdon Hall, and Staines following. There were eight in competition. Mr. Moore improved his position in the corresponding class for incurved, a u at stand securing him the premier award. Mr. Packman followed, Mr. Ridge, gardener to Lady Ashburton, Addiscombe Farm, Croydon, being third. Four others competed.

There were three stands of Japanese Anemone-flowered, and Mr. Packman's first prize blooms were fine. Pompons, twelve varieties, in bunches of three, were best shown by Messrs. Pascoe & Edwards, The Nurseries, Balham. The latter was successful with a hand bouquet of Chrysanthemums, Messrs. Perkins & Sons, of Coventry, being placed equal first.

The local gardeners' classes included groups, specimens, and good blooms. Some of the chief prizewinners were Messrs. Hudd, Dodson, Nunn, Adlam, and Cox.

The classes provided for bouquets, epergnes, and baskets of Chrysanthemums were an admired feature of the Exhibition. Mrs. Birdseye, 23, Lanier Road, was first and Mrs. Wickham Jones second for a hand bouquet, the last-named lady winning with a basket; Miss Hoyton, 24, Rycroft Road, Lewisham, following. These were all charming arrangements. Mrs. Jones and Mrs. Birdseye won with epergnes, and the former lady also accounted for the first prize for a decorated table, Mrs. E. A. Searle, Ringstead Road, being second.

The silver medal offered by Messrs. Wood & Son for the best trained specimen fed with their liquid manure powder went to Mr. W. Green, 3 Patrol Place, Catford, Mr. Lapwood being second. Mr. T. S. Ware's prize for six bunches of the useful decorative Chrysanthemum, Mrs. H. J. Jones was won by Mr. Edwards. Messrs. Davis and Jones also offered prizes for Princess of Teck and Mrs. Norman Davis, but the classes did not fill.

The most noteworthy miscellaneous exhibits were fine groups of Chrysanthemums from Messrs. Davis & Jones and Laing & Co., a large collection of fruit from Messrs. G. Bunyard & Sons, and cut blooms of Chrysanthemums and Zonal Pelargoniums from Messrs. Cannell & Sons, which were highly commended. Messrs. Carter & Co. exhibited Primulas and Mr. Arthur Robinson Cyclamens, the latter highly commended. Mr. Benjamin Field had a large stand of horticultural sundries, Mr. George a basket of Grapes, and Mr. Cox (a prizewinner with Chrysanthemums) a collection of Potatoes, some being very fine.

It may be added that on the second day of the Show a gold watch was presented to Mr. Drake, the able and popular Secretary, by a few friends of the Society, in recognition of the zeal he had displayed on its behalf.

#### BATH.—NOVEMBER 9TH AND 10TH.

ALTHOUGH comparatively rather slow in starting a Chrysanthemum show, the Bath horticulturists cannot be twitted for any supineness now that they are thoroughly interested in the matter. At any rate, the Committee, with Messrs. King and Pearsons respectively as Chairman and Secretary, do their best to maintain the reputation of the district, with the result of bringing together what most probably was one of the best all-round exhibitions of the season. The prizes offered throughout are fairly

liberal and the competition most keen, but we are afraid the unfavourable weather, experienced on the first day especially, militated against the chances of a large attendance of visitors.

**SPECIMEN PLANTS.**—These, one of the Judges, a prominent Liverpool exhibitor, rightly characterised as being very superior, and, in our opinion, the best ever brought together in the district. The premier prize for six large-flowering varieties was awarded to Mr. G. Tucker, gardener to Major W. P. Clarke, Trowbridge, who had grandly flowered specimens, about 4 feet through, of Mrs. Dixon, Golden Christine, Mrs. Forsyth, Mrs. Glenny, Mrs. Rundle, and Pink Venus. Mr. S. Kerslake, gardener to the Rev. E. Handley, Bath, staged pretty even blooms, and was second, the third prize going to Mr. T. W. Fisher, gardener to R. B. Carter, Esq., Bath. With four varieties Mr. A. W. Southard, gardener to F. J. Walker, Esq., was a good first, having Sir Stafford Northcote (very fine), and Mrs. Forsyth, Pink Venus, and Mrs. Rundle, also good. Mr. A. Hawkins, gardener to T. Jolly, Esq., was second, and Mr. J. Weston, gardener to the Rev. C. C. Layard, third. The best three standards of incurved varieties were shown by Mr. M. Cole, gardener to S. Tredwell, Esq., these consisting of Empress of India, Mrs. Glenny, Mrs. Rundle, all very good. Mr. J. Southard, gardener to W. J. Brown, Esq., was a close second. Pyramids were well shown by Messrs. W. Taylor, gardener to S. P. Badd, Esq.; J. Southard; and T. W. Fisher, who received the awards in the order named. For a large flat trained and well flowered Mrs. Rundle, Mr. J. Southard was awarded the first prize and also the silver medal of the National Chrysanthemum Society, Mr. T. W. Fisher being a creditable second, and Mr. W. Taylor third. Capitally flowered Japanese varieties were shown. Mr. G. Tucker was again first, such sorts as La Frisure, Hiver Fleuri, Madame Sevin, and La Nymph being particularly good. Mr. S. Kerslake was second, and Mr. T. W. Fisher third, both staging creditably. With four plants Mr. M. Cole was first, having beautifully flowered specimens of Margot, Madame Bertie Rendatler, Madame de Sevin, and L'Isle des Plaisirs. Mr. T. W. Fisher was second, and Mr. W. Taylor third. With three standards Mr. M. Cole took the lead, being closely followed by Mr. B. B. Titley, both having fresh and beautifully flowered plants. Pyramids of Japanese sorts were not so good as usual, but the Anemone-flowered were fairly well shown. Classes are also provided for conservatory plants, but all compete with small trained plants instead of more naturally grown, and therefore more serviceable examples. Groups of Chrysanthemums to occupy a space not more than 12 feet by 6 feet were arranged by six growers, and all were highly meritorious. They were disposed down one side of the hall, and the majority of them were not less than 7 feet high at the back and well finished at the front. Mr. J. Southard was rightly awarded the first prize, the whole of the plants used being clothed with good foliage and had very fine blooms. Mr. W. Taylor was second, and Mr. A. A. Walters third.

**MISCELLANEOUS PLANTS.**—Prizes were offered for a great variety of flowering and fine-foliage plants, and capital examples were brought together. Mr. T. W. Fisher was the only exhibitor of six Orchids, and was awarded the first for fairly good Oncidium Forbesi, Oncidium varicosum, Odontoglossum graude, and other well known species. Primulas were wonderfully good. For twelve plants Mr. C. Fisher was first; Mr. Mould, gardener to E. E. Bryant, Esq., second; and Mr. T. J. Tait, gardener to Mr. W. Pumphrey, third. With six plants Mr. E. Reeves was first and Mr. M. Cole second. Poinsettias were good, and with these the prizewinners were Messrs. M. Cole, W. Pumphrey, and F. J. Walker. Mr. Pumphrey was first for Bouvardias, Mr. A. A. Walters second, and Mr. W. C. Drummond third; and with Cyclamens the prizewinners Messrs. A. A. Walters and W. C. Drummond. Excellent table plants were shown, but the Judges displayed strange taste in their selections. Mr. G. Shelton, gardener to W. K. Wait, Esq., Clifton, was rightly placed first, Messrs. Cooling & Sons second, and Mr. A. A. Walters third. Three groups of mixed plants arranged for effect were in competition, but here again the Judges were at fault, the first prize being awarded to the least meritorious; the second and third prize groups comprising a greater number of choice flowering and fine-foliage plants well grouped. Mr. W. J. Mould was first, Messrs. Cooling & Sons, Bath, second; and Mr. W. C. Drummond third. Messrs. W. J. Mould, H. Podger, W. C. Drummond, W. Dobson, J. Murch, T. W. Fisher, and H. Hawkins were the principal prizewinners in the classes for choice fine-foliage and flowering plants.

**CUT BLOOMS.**—There were several exhibitors new to Bath well to the front with the e. The best twenty-four large flowering varieties were staged by Mr. J. Horsefield, gardener to Lord Heytesbury, of Heytesbury House, who had a very creditable collection. Mr. H. W. Ward, gardener to Lord Radnor, Longford Castle, was only a few points behind, and took the second prize, his best bloom being Lord Alcester (awarded the silver medal of National Chrysanthemum Society). Mr. J. Baylis was third. With twelve varieties, Mr. J. H. Copp, gardener to W. E. S. Erle-Drax, Esq., Sherborne, was well first; Mr. R. Richard, Bristol, followed closely. With six varieties the prizewinners were Messrs. J. Miller, gardener to F. Tagart, Esq., Bristol, M. Cole, and S. Andrews, gardener to A. G. Hayman, Esq., Frome.

The competition with Japanese varieties was close and good. Mr. H. W. Ward was rightly awarded the first prize for twenty-four varieties, among these being very fine fresh examples. Mr. Horsefield took the second prize, he also having fine blooms. Mr. R. Richards was third, and also first for twelve varieties. Mr. J. H. Copp was second, and Mr. Ward third in this class. The best six varieties were staged by Mr. Miller, the second prize going to Mr. B. Hopkins, gardener to John Baily, Esq., Frome, and the third to Mr. S. Andrews, all having very good blooms of popular sorts. Remarkably good blooms were staged by Mr. R. Richards in the class for Anemone-flowered sorts. Mr. G. Tucker was second, and Mr. T. Hobbs third. The best Pompons in bunches were staged by Messrs. Copp, F. Hooper, and Hawkins. The first prize for a vase or epergne of flowers was awarded to Mr. W. Dobson, Bristol; Mr. E. T. Hill, Bristol, being second, and Miss E. E. Hill third. Mr. C. Winstone, Clifton, had a huge yet well made bouquet, and was first, Miss Lambden being a good second, and Mr. W. Dobson third.

**FRUIT AND VEGETABLES.**—Some grand Grapes were staged, Pears and Apples being also plentiful and good. The best collection of six dishes of fruit was staged by Mr. W. Pratt, gardener to Lord Bath, Longleat, these consisting of very fine Muscat of Alexandria and Alicante Grapes, a good

Golden Perfection Me'on, Sa'wey Peaches, Forelle Pears, and Coe's Golden Drop Pears. Mr. W. Nash, gardener to the Duke of Beaufort, was a very creditable second, losing points principally with white Grapes, Mr. J. Ellicott, gardener to H. W. Tugwell, Esq., Bath, being a close third. Alderman Chaffin (Mr. W. Taylor, grower, Bath), was placed first for four bunches of Grapes in two varieties, but he was fortunate in getting the "benefit of the doubt," the exhibits of Mr. Pratt apparently equalling Mr. Taylor's. Both had Alicante and Muscat of Alexandria, and what Mr. Pratt lost with the former he fully regained with his Muscats. Mr. Nash had very well finished Alicantes and fine Gros Colman, and took the third prize. Alderman Chaffin was again first for three bunches of black Grapes, winning with three grand bunches of Lady Downes, these only requiring a little more colour to make them perfect. Mr. Nash followed with good Alicante, and Mr. Hopkins was third with the same variety in good condition. There were also fine Gros Guillaume shown in this class. In the class for a white Grape, Mr. Pratt was well first with superb Muscat of Alexandria, Mr. Chaffin following with fine bunches of the same variety, and Mr. Ellicott was a good third. Mr. W. G. Pragnell, gardener to J. D. Wingfield Digby, Esq., Sherborne Castle, was first in a good class for six varieties of Pears, having fine clear fruit of Pitmaston Duchess, Marie Louise, Beurré Diel, Winter Neli, Glou Morceau, and Doyenné du Commerce. Mr. W. Bannister, gardener to H. St. Vincent Ames, Esq., Bristol, was a good second, and Mr. S. Downs third. For four varieties, Mr. G. Pymm, gardener to Mrs. Gouldsmith, Trowbridge, was first, having fine dishes of Pitmaston Duchess, Beurré Diel, Beurré Clairgeau, and Van Mons Leon Leclerc. Mr. W. Fidler, gardener to Baron C. de Tuyl, was second, and Mr. J. Ellicott third. Mr. Garraway, Bath, was first for six varieties, these consisting of highly coloured dishes of Woodstock Pippin, Empress Eugenie, Ribston Pippin, Cox's Orange Pippin, Blenheim Pippin, and King of Pippins. Mr. E. Hall was second, and Mr. Bannister third. With four dessert varieties, Mr. Ward was first, Mrs. Pinder second, and H. Taylor third. A fine lot of culinary Apples were shown. Mr. Pragnell was first for six varieties, these consisting of Alfriston, Mère de Méoage, Gloria Mundi, Peasgood's Nonesuch, Warner's King, and Blenheim Pippin. Mr. G. Garraway was second, and Mr. J. Aplin, gardener to W. M. Baker, Esq., Gloucester, third, the last named having a fine dish of Lord Clyde. In a large class for one variety, Mr. Ward was first with Blenheim Pippin; Mr. Pragnell second with Peasgood's Nonesuch; and Mr. Aplin third. Collections of vegetables exhibited on a space 4 feet by 3 feet were very good indeed, the three prizewinning lots being nearly of equal merit. Mr. Copp was first, Mr. G. Garraway second, and Mr. Pragnell third.

#### WESTON-SUPER-MARE.—NOVEMBER 9TH.

THE third Exhibition of this Society was a most successful one in every way. A marked improvement was evident in nearly all the plant classes, and a much better lot of fruit was shown than on previous occasions. Cut blooms were not quite so good as last year, owing to the absence of two prominent Taunton exhibitors. Their places, however, were fairly well filled by fresh competitors from Wells, and the local growers staged many good blooms. Messrs. W. H. Vanes and S. Lewis are the Honorary Secretaries, and these gentlemen, ably assisted by a practical Committee, managed the whole affair in capital style.

The best six plants of large flowering varieties were staged by Mr. W. Brooks, Weston-super-Mare, who had neat well-flowered specimens of Gloria Mundi, Prince of Wales, and the Rundle family. Mr. Tatchell, gardener to A. G. Andrews, Esq., Wells, was a good second, and Mr. W. Brown, gardener to the Rev. W. W. Aldridge, Weston-super-Mare, third. In a class for four plants Mr. C. Holland, gardener to W. Ash, Esq., Weston-super-Mare, was well first; Mr. H. Lambert second; and Mr. W. Treble, gardener to Mrs. Mager, third. Mr. Holland had the best six plants of Japanese varieties, among these being beautifully flowered specimens of Margot, Madame Berthie Rendatler, Elaine, and Bouquet Fait. Mr. W. Brooks was a close second, and Mr. G. Tatchell third. With four plants Mr. W. Brown was first with freely flowered naturally grown specimens of Source d'Or, Little Beauty, and Madame Berthie Rendatler. The strongest competition was in the class for three standards of any variety. Mr. C. Holland was placed first with creditable examples of Mrs. Forsyth, Guernsey Nugget, and Fingal. Mr. M. Cole, gardener to S. Tredwell, Esq., Bath, followed closely, the third prize going to Mr. W. Brooks, and a fourth was awarded to Mr. Tatchell. In the class for the largest and best grown specimen of any variety, Mr. C. Holland was first for a well-flowered finely trained Mrs. Rundle, Mr. W. Brooks being a good second with Mrs. Dixon. The successful exhibitors of pyramids of incurved and Pompon varieties were Messrs. Holland, Brooks, and W. Lewis, gardener to E. J. Cole, Esq. Mr. C. Holland was first for six Pompons; and Mr. H. B. Harrington, Weston-super-Mare, for four plants, the other prizes being won by Messrs. W. Brooks, H. Horstman, and W. Lewis. Four very creditable groups of Chrysanthemums were arranged, the plants in the first and third prize groups having excellent foliage as well as good blooms. Mr. W. Brooks was first; Mr. M. Baines, gardener to Cecil Smyth-Piggott, Esq., second; Colonel Mordaunt third; and Mr. W. Lewis fourth. Several good Palms were included in Mr. W. Brooks' first prize group of six stove and greenhouse plants, and Mr. C. Holland was a good second, and W. Lewis third. Mr. Brooks was also first with six Ferns, these consisting of Dicksonias and other good Tree Ferns. Mr. W. Lewis followed closely, and Mr. C. Holland was third. Mr. W. Brown was a good first with six Pimulas, Mr. C. Holland being second, and Mr. W. A. McKenzie (gardener to Craswell Crump, Esq., Wells), third. Mr. W. Brooks was easily first with a choice group of miscellaneous plants arranged for effect, and Mr. W. Lewis second.

In the class for twenty-four cut blooms of large flowering Chrysanthemums Mr. McKenzie was well first, his best being Empress of India, Lord Alcester, Golden Empress, Inner Temple, Prince Alfred, Princess of Wales, Eve, Lord Wolseley, Isabella Bott, Empress Eugenie, John Salter, and Mrs. W. Shipman. The second prize was taken by Mr. Brooks, who had good blooms of Lord Wolseley, Prince Alfred, Mrs. Rundle, and other sorts just named. Mr. Tatchell was third. With twelve varieties Mr. M. Masters was first; and Mr. E. Wheeler, gardener to Mrs. Charrington had a similar award for six varieties. Japanese varieties were much better represented.

Mr. McKenzie was well first, his best being Meg Merrilies, Madame Audignier, Madame Lacroix, Madame Sevin, Belle Paul, Madame Laing, Thunberg, and Fair Maid of Gaersey. Mr. Tatchell was a creditable second, and Mr. W. Brooks a close third. Mr. C. Holland was first for twelve varieties, and Mr. W. Coates, gardener to Mrs. Miller, for six. The best twelve Anemone-flow red were shown by Mr. W. Brooks, who had Madame Bertha Pigay, Fabien de Médiana, Lily Marguerite, Duchess of Edinburgh, Minnie Chate, and Madame Cabrol fresh and good. Mr. C. Winstone, Clifton, fully deserved the award of a first prize for a basket of autumn foliage and fruit; Mr. W. Brooks being second, and Mr. W. Treble third. Mr. Winstone was also first for a magnificent hand bouquet, the second prize going to Mr. Brooks, who also had a grand but rather closely packed bouquet.

Several stands of black Grapes were staged. Mr. W. DuFurn, Weston-super-Mare, was well first for perfectly finished Alicante, Mr. J. Coates being a good second with the same variety. In a corresponding class for any white sort Mrs. Miller was first with two excellent bunches of Muscat of Alexandria, Mr. W. Lewis being second with Syrian. The best four dishes of Pears were staged by Mr. McKenzie, who had good Marie Louise, Hacon's Incomparable, Beurré Diel, and Vicar of Winkfield; Mr. W. Duffurn was second. Mr. J. H. Virgo was well first for four varieties of dessert Apples, and Mr. E. Brooks for culinary sorts. Other successful exhibitors of Apples and Pears were Messrs. C. Clarke, H. Marshall (gardener to R. Cox, Esq.), and W. Lewis. Good prizes were offered for collections of vegetables, and three good lots were staged. Mr. T. Tilley, gardener to Colonel Cotgrave, Banwell, was easily first, his collection including several of Sutton's best varieties. Mr. J. Hall, Cracombe, was second, and Mr. McKenzie third.

#### ASCOT AND DISTRICT.—NOVEMBER 9TH AND 10TH.

THE fourth Show of this flourishing Society was held on the above dates in the spacious halls attached to the Grand Stand, Ascot Racecourse, and proved as regards exhibits highly successful, although the unfortunate state of the weather must, we fear, have militated against a financial success. In the neighbourhood are some first-class growers of both group plants and cut blooms. They would undoubtedly do credit to themselves if exhibiting at Metropolitan exhibitions, the winning stands being equal to those at the National Society's Show. Groups are always well done, and this year all were remarkably good, the competition for those of a miscellaneous nature being very keen. Seven handsome groups were arranged round the sides of the principal hall. Fruit and vegetables also were well represented, quite a grand display of the latter being made by the cottagers.

PLANTS.—For the best group of Chrysanthemums to occupy a semi-circular space not exceeding 6 feet in radius, Mr. Lane, gardener to Miss J. Dunning-Smith, King's Ride, Ascot, was first with handsome dwarf plants well arranged. Specially noticeable were plants of Meg Merrilies scarcely 2 feet in height from the pot, and each carrying three flowers fit for an exhibition stand. Second Mr. Hawthorn, gardener to the Rev. B. Pearce, Ascot. Third Mr. Hughes, gardener to H. F. de Paravicini, Esq., Heathfield, Ascot, with taller plants and fine flowers, but badly finished in front. Fourth Mr. Bird, gardener to C. Barnett, Esq. Mr. Lane was the principal exhibitor of trained plants, taking first prizes for four distinct varieties, also for three standards, King of Crimsons among the latter in fine condition.

CUT BLOOMS.—The principal class was that for thirty-six blooms, to comprise eighteen incurved distinct varieties and the same number of Japanese, a handsome and valuable silver challenge cup going to the first prizewinner in this class. Seven competitors entered, all their collections being good. Mr. Page, gardener to A. Southard, Esq., Fern Lodge, Bracknell, was first, putting up two remarkably good stands of blooms, the Japanese especially being extremely large, deep, and grandly coloured. They comprised:—Back row—Triomphe de la rue des Châlets (very fine), Fair Maid of Guernsey, Madame C. Audignier, Japonaise, Meg Merrilies, and Val d'Andorre. Middle row—Mlle. Lacroix, Ralph Brocklebank, M. Marrouch, Maiden's Blush, Madame J. Laing (fine), and G'oriosum. Front row—Criterion, M. Freeman, Thunberg, Balmoreau, Madame Banche Pigny, and J. Delaux. The incurved were:—Back row—Queen of England, Empress of India, Alfred Salter, Lord Alcester, Prince Alfred, and Golden Empress. Middle row—Empress Eugenie, Lord Wolseley, Jeanne d'Arc, Baron Beust, St. Patrick, and John Salter. Front row—Mrs. Heale, Princess Beatrice, Mrs. Shipman, Jardin des Plantes, Lady Hardinge, and Mabel Ward. Mr. Lane was a good second. Third Mr. Tomlin, gardener to T. Ashby, Esq., Braeside; this exhibitor being last year's winner of the challenge cup. Four classes were provided for incurved blooms, and fine flowers were staged, the competition being keen in each class. For eighteen, distinct, seven stands were entered, first, Mr. Page, having large solid blooms. Second Mr. Popple, gardener to the Hon. Lady Stepney, Woodend, Sunninghill. Third Mr. Paul, gardener to J. C. Bowring, Esq., Forest Farm, Windsor Forest, with large but rough uneven flowers. In the class for twelve incurved Mr. Hibbins, gardener to General Thornhill, Lavender Farm, Winkfield, was first; Mr. Lane second; and third Mr. Sinclair, gardener to the Marchioness of Downshire, Easthamstead Park, in whose stand was a remarkably fine bloom of Jardin des Plantes. For six incurved Mr. Thorn, gardener to J. T. Mackenzie, Esq., Sunninghill, was first; Mr. Godfrey, gardener to H. C. Rothery, Esq., Bagshot, second; and Mr. Hughes third. For six incurved, one variety, Mr. Paul was first with extra fine blooms of Lord Alcester, one of which was awarded the National Chrysanthemum Society's certificate of merit for the best bloom in the Show.

The same number of classes was provided for Japanese blooms, the competition in every case being keen. In the open class for eighteen, Mr. Page again won first honours, among ten competitors, staging in fine style varieties almost the same as those before mentioned; the variety Moonlight was very good in this stand; second, Mr. Popple; third, Mr. Tomlin; fourth, Mr. Hughes. The next class for twelve varieties was as strongly contested as the preceding one, Mr. Lane securing the first position with excellent blooms, Ralph Brocklebank being very fine, also Belle Paul, Thunberg, J. Delaux, Criterion, and Triomphe de la Rue des Châlets; second, Mr. Hibbins; third, Mr. Sinclair. In the six of one variety class, Mr. Pope was first with remarkable flowers of Triomphe de la Rue des Châlets.



One class was provided for twelve reflexed, Mr. Page securing another first with a grand stand of blooms, King of Crimson, Jewess, Cloth of Gold, Distinction, Phidias and Mount Etna being especially fine.

As previously mentioned groups of miscellaneous plants were well represented, and the Committee would do well to increase the prizes in this class. Mr. Sinclair won first honours with an excellent arrangement, consisting largely of Calantbes, Palms, Dracenas, Ferns, with a suitable edging of Panicum, &c.; second, Mr. Thorn, who freely used Cocos Weddelliana and Crotons, but was rather deficient in flowering plants; third, Mr. Wells, gardener to Mrs. Ravenhill, Winkfield. Plants for dinner table, Primulas, Solanums, Cyclamen, &c., were shown in large numbers, and arranged down the centres of the tables produced a pretty effect.

The display of fruit was good, Grapes, Apples, and Pears being extensively shown. For two bunches of black Grapes, Mr. C. Cooper, Sunninghill, was first with good Gros Colman; second, Mr. Hughes, with Alicante, medium bunches, very fine berries; third, Mr. Wells. With white Grapes, Messrs. Sinclair, Lane, and Bird were the prizetakers. For three dishes of Apples and the same number of Pears (dessert), Messrs. Godfrey, Holdforth, and Fenner won the honours. Several other classes were equally good, many handsome dishes of Pears and Apples being staged.

Vegetables, for which Messrs. Sutton & Sons offered special prizes for six varieties, made a fine display, the produce throughout was excellent. Mr. Godfrey was first, Mr. Hughes second, and Mr. Wells third. Messrs. Sutton & Sons staged fifty dishes of Potatoes, large, clean samples of their well-known varieties. Much praise is due to Mr. Watkins, Secretary (who also secured the silver cup in the amateur classes); also to Mr. Hay for the excellent staging arrangements, the management in every way being a great improvement upon last year's show.

#### STREET (SOMERSET).—NOVEMBER 11TH.

VERY marked progress in Chrysanthemum-growing has been made in this district, and a capital display of plants and cut blooms was the result. These were well arranged, and shown off to the best advantage in the Crispin Hall, a remarkably suitable place for holding such an exhibition, much credit being due to the Honorary Secretary, Mr. A. D. Porter, and the Committee generally.

The principal class was for groups consisting largely of Chrysanthemums, and four competitors entered for the prizes. Mr. F. Edwards, gardener to James Clark, Esq., Street, was awarded the first prize, his group comprising many well-grown plants with fine blooms, and arranged in good style, such sorts as Fair Maid of Guernsey, Comte de Germiny, Madame C. Audiguier, Mrs. Rundle, Thunberg, Hiver Fleuri, Mons. Henri Jacotot, Gladiateur, and Jardin des Plantes being well shown. The second prize was well won by F. J. Clark, Esq., Street, his exhibit being good alike as regards both quality and arrangement, a few Orchids being included. The best Chrysanthemums were Cullingfordi, Val d'Andorre, Comte de Germiny, Meg Merrilies, Fair Maid of Guernsey, and Venus. The third prize was won by Mr. G. Chislett, gardener to Mrs. Rees Mogg, Glastonbury, who had capital plants, but the effect was sadly marred by the massing of pink shades on one side of the group. Mr. Chislett obtained the first prize (a silver medal of the National Society) for six trained large flowering varieties, these consisting of capitally flowered and not too formally trained plants of Mrs. Dixon, Lord Alcester, Jeanne d'Arc, Venus, Prince of Wales, and Mr. G. Glenn. The second prize was awarded to Mr. G. Potter, gardener to A. Colson, Esq., who had more formally trained specimens, while Mr. J. Mundy was third. Japanese varieties were capitally represented, the prize plants being trained in good style and beautifully flowered. Mr. Potter was first, and received a silver medal for six plants, consisting of Nuit d'Hiver, Madame Berthie Rendaler, Mdlle. Lacroix, Margot, Peter the Great, and Comte de Germiny. Mr. Chislett was a good second, his best being Dormillion, James Salter, and M. Henri Jacotot. Mr. J. Mundy had the remaining prize. The first prize for six plants, any varieties, was awarded to Mr. Potter; Mr. C. Bacon, gardener to Miss Ansell, being a good second. Mr. J. Mundy, an amateur, staged a capital lot of plants, and was first in several classes from which professional gardeners were excluded. Mr. J. Payne, gardener to the Lord Bishop of Bath and Wells, Wells, Palaeo, was first for table plants and Primulas; and Messrs. T. Tatchell, gardener to A. J. Andrews, Esq., Wells, J. Potter, and G. Chislett, were also successful in the different plant classes.

There was quite a large display of cut blooms, the competition being close in every class. The first prize for twenty-four blooms, twelve incurved and twelve Japanese, was won by Mr. J. Payne, who had Golden Empress, Princess of Wales, Prince Alfred, Empress Eugenie, Princess Beatrice, Cherub, Eve, and Lord Alcester fresh and good; while the best Japanese were Triomphe de la Rue des Châlets, Madame C. Audiguier, Baronne de Prailly, Mons. Tarin, M. Ardene, J. Delaux, and Flamme de Punch. Mr. W. A. McKenzie, gardener to G. Cresswell Crump, Esq., Wells, was only a few points behind, several of his blooms, however, lacking freshness. Mr. T. Tatchell was a good third. In the class for twelve incurved varieties the first prize, a silver medal of the National Society, was awarded to Mr. McKenzie, his best blooms being Empress of India, Golden Empress, Lord Wolsley, John Salter, Eve, Mrs. Heale, and Mrs. W. Shipman. Mr. Tatchell was a good second, and Mr. Payne third. Another bronze medal was awarded to Mr. Payne for the best twelve Japanese varieties, among which were good blooms of M. Tarin, Boule d'Or, Dormillion, Japonaise, and Madame C. Audiguier. Mr. Tatchell was again second, and Mr. McKenzie third. The prizewinners with Pompons were Messrs. Bacon, Payne, and F. J. Clarke. Mr. Tatchell was first for a vase of Chrysanthemums with Fern fronds added, and Mr. Summerhayes second; and for a bouquet Mr. Tatchell was first, Miss Summerhayes second, and Mr. Payne third. Mr. Payne was first for a beautiful basket of hardy foliage and berries, and Miss Summerhayes second.

#### LINDFIELD.—NOVEMBER 10TH AND 11TH.

THE annual Show of the Lindfield Chrysanthemum Society was held on Thursday and Friday last, when, notwithstanding the falling off in the competition for groups, there was a very good show, which was arranged in the assembly room. There were only two entries for groups, the premier

award going to Mr. A. G. Brown, gardener to W. Savile, Esq., Finches. There were very good blooms in this group, which were tastefully arranged. The second prize was awarded to Mr. Braysber, gardener to Mr. Cale, Lindfield. The cut blooms, especially Japanese, made a good show. Mr. Venn, gardener to W. Thuday, Esq., had some excellent blooms in the first prize stand of twenty-four (twelve incurved and twelve Japanese), the Japanese being especially well finished. A good collection of Apples, not for competition, from Mr. Hodges, gardener to S. C. Gibbons, Esq., Walstead House, Lindfield. The majority of the prizes were taken by the following:—Messrs. A. J. Brown, T. Venn, J. Hodges, S. Horscroft, gardener to—Potter, Esq. There was keen competition for the special prizes for fruit and Potatoes, given by various nurserymen. Notwithstanding the unfavourable weather the Committee have reason to believe they will have a balance in hand. At the dinner, held during the day, the Chairman, Mr. A. J. Brown, referred to the benefits of the Gardeners' Orphanage Fund and stated that he hoped that the gardeners of Sussex would send in their names and subscriptions to him as soon as possible, he being Local Secretary for the county.

#### NEWPORT, ISLE OF WIGHT.

THE annual Exhibition took place at the Drill Hall on Wednesday and Thursday, and as regards the number and quality of the exhibits was a great success. Of the cut blooms 900 were arranged in the centre of the hall. There was a very keen competition in the open class, as well as in the class for forty-eight blooms, twenty-four Japanese and twenty-four distinct varieties. A great feature in the Show was the ladies' class, no less than fifteen entering with bouquets and baskets, which the Judges had a difficulty with. Great praise is due to Mr. A. E. Marvin, the popular Secretary, and the Committee, for the way the Show was carried out.

Groups of Chrysanthemums, any variety, gardeners' class, Isle of Wight only.—First, Mr. G. Freeland. Second, Mr. G. E. Marvin. Six specimen plants, incurved or reflexed.—First, Mr. G. Freeland. Second, Mr. A. E. Marvin. Three specimen plants.—First, Mr. G. Wilkins. Second, Mr. W. Morris. One specimen.—First, Mr. G. Wilkins. Second, Mr. G. Freeland. Nurserymen's class, group, any variety.—First, Mr. J. W. Gould. Six specimens.—First, Mr. J. W. Gould. Six specimen Japanese.—First, Mr. J. W. Gould. Twenty-four cut blooms, incurved or reflexed, eighteen varieties.—First, Messrs. H. Drover & Son, Ventnor. Twenty-four Japanese.—First, Mr. J. W. Gould. The amateurs' class was well represented. Mr. F. Cooper taking all the first prizes for cut blooms. In the cottagers' class there were over fifty entries for cut blooms and pot plants. Ladies' class, best arranged basket of Chrysanthemums and Ferns.—First, Mrs. J. H. Sbarland. Second, Miss Lucy Sanders. Third, Miss Kate Marvin. Epergne of Chrysanthemums and Ferns.—First, Mrs. Morris. Second, Miss A. A. Hellaby. Equal third, Miss Stark and Miss G. R. Marvin. Open classes, forty-eight cut blooms, twenty-four Japanese, distinct, twenty-four incurved, distinct.—First, Messrs. W. & G. Drover, Fareham. Second, Mr. J. Gash. Six cut blooms, any variety.—First, Messrs. W. & G. Drover. Second, Mr. W. H. Jobling. Third, Messrs. H. Drover & Son. Twelve cut blooms, Anemones.—First, Messrs. W. & G. Drover. Second, Mr. J. Gash. Third, Mr. G. Ingram. Special prizes, the premier bloom in show, incurved, Queen of England, first, Messrs. W. & G. Drover. The best Japanese in the show was Carew Underwood, from Messrs. W. & G. Drover.

#### WALTON AND WEYBRIDGE.

THE thirteenth annual Exhibition of this Society was held in the Public Hall, Weybridge, on the 10th inst., and was well up to the average, although there was a slight falling off in some of the plant classes. Despite the inclement weather the Show was well attended, and under the management of Mr. Masters (Secretary), assisted by an able Committee, everything passed off satisfactorily, but want of space prevented us giving an account of all the exhibits. For six trained plants (large flowering) there were only two entries, the first prize being won by Mr. Reed, gardener to E. Pettit, Esq., Oatlands Park, second Mr. Plowman, gardener to C. Lavers Smith, Esq., Walton, both having neatly trained plants with rather small flowers. For three plants, first Mr. Millican, gardener to H. Cobbett, Esq., Walton; second Mr. Doyle, gardener to E. Aylward, Esq., Hersham. Standards were only moderate; for three varieties Mr. Reed, Mr. Plowman, and Mr. Millican gained the prizes in the order of their names. Single specimen—first Mr. Reed, with a good plant of Pink Christine. Pompon varieties did not claim much comment, the majority of the plants being thin and the flowers not at their best; but in the single specimen class Mr. Reed was first with a beautifully flowered plant of Golden Madame Marthe; second, Mr. Plowman with Marguerite de Coi, nearly as good; third, Mr. Millican with the same variety.

Cut blooms were numerous and generally well shown, especially the Japanese, but the incurved varieties have been seen better, many of the flowers lacking depth. For twenty-four varieties, incurved, open class, first, Mr. R. Cawte, gardener to P. J. Robinson, Esq., Esher, with a very even lot; second, Mr. Carpenter, gardener to J. Abbott, Esq., Walton; third, Mr. Plowman. For twenty-four incurved (home class), first, Mr. Plowman; second, Mr. Carpenter; third, Mr. Reed. Twelve blooms, first, Mr. Doyle; second, Mr. Thorne, gardener to A. E. Hood, Esq., Hersham; third, Mr. Quarterman, gardener to E. Smith, Esq. Reflexed varieties were well shown by Messrs. Carpenter, Plowman, and A. Turner, Esq., Walton. Mr. Reed being disqualified, his stand unfortunately containing a bloom of Salteri. Japanese were splendidly shown by Mr. Plowman, who was first for twenty-four varieties with very bright clean flowers, Messrs. Carpenter and Reed following in the order of their names. Twelve blooms, first, Mr. Thorne; second, Mr. Quarterman; third, Mr. Millican. Mr. Thorne's stand contained beautiful blooms of Ralph Brocklebank and Gloriosum, Mr. Millican's a grand Belle Paule. There were three stands of Japanese Anemones. Mr. Plow-



man was first with a fine lot, beating Mr. Carpenter's, which were first at Kingston; Mr. Millican was third.

One of the features of the Show was a new class (prizes offered by the President, H. Cobbett, Esq.) for twelve large flowering blooms distinct, to be shown as grown with foliage on the stems, not less than 12 inches from the top of the box. This brought seven stands, the first prize going to F. Hopkins, gardener to J. Widderspoone, Esq., Walton; second, Mr. Carpenter; third, Mr. Plowman. Special prize for group of Chrysanthemums, first, Mr. F. Hopkins; second, Mr. Reed. For floral ornament and hand bouquet, Mr. Millican was first in each instance, there being strong competition. For nine table plants, first, Mr. Reeves gardener to W. Hemett, Esq., Oatlands Park. Mr. Doyle was first for Primulas.

#### PUTNEY AND DISTRICT.—NOVEMBER 15TH AND 16TH.

THE tenth annual Exhibition was held on the dates named in the Cromwell Hall, Putney, a much more capacious and suitable building for this purpose than the Assembly Rooms, and the Show was altogether worthy of the place and district. In the large group class of not less than twenty varieties there was excellent competition, the silver cup being awarded to Mr. A. Newell, gardener to Sir Edwin Saunders, Fairlawn, Wimbledon, with a freely disposed assortment of plants bearing handsome blooms and deep green foliage. Mr. G. Stevens, St. John's Nursery, was second with a remarkably bright group, consisting mainly of Japanese varieties, the face of the group being, perhaps, rather too smooth, but the arrangement undeniably beautiful. Third honours fell to Mr. J. Carter, gardener to H. J. Parry, Esq., Heathside, Wimbledon, the group, like the first, including many incurved varieties, the Japanese, that relieve the weight, being rather weak. Mr. James Townsend was adjudged the remaining prize for an arrangement that would have been first at many shows, though rather close packing was apparent. The plants sloped from 8 feet at the back to a foot at the front, and the group was on that account admired. Prizes were awarded for smaller groups, but we failed to obtain the names of the winners.

In the class for four specimen plants Mr. Pickling, West Lodge, Mortlake, secured the first position with upright trained plants 3 feet high, bearing from twenty to thirty fine blooms and splendid foliage, Mr. C. Bentley, gardener to H. Smith, Esq., having to take a second place with dwarf-trained and very good plants. Third, Mr. C. Bentley. This exhibitor staged the best pair of Japanese plants, very good indeed, also the best specimen incurved, a fine plant of Venns; Mr. J. Bentley being second. Mr. Elliott, gardener to Mrs. Harrison, Mortlake, was placed first for a standard, Mrs. Dixon, with a beehive-shaped head, 3 feet across the base and 2½ feet high; Mr. C. Bentley closely following; he was first also in the corresponding Japanese class with Roseum superbum, quite a bouquet; Mr. J. Bentley very closely following.

In the class for twenty-four incurved cut blooms, distinct, the contest was exceedingly keen between Mr. E. Coombs, gardener to W. Furze, Esq., Roseland, Teddington, and Mr. Sullivan, gardener to D. B. Chapman, Esq., Roehampton, the former winning by the skin of his teeth. Mr. Sullivan had the best back row blooms, including the premier in the Show (Lord Alcester), for which the prize was offered by Mr. Icton, but lost a few points in the front rows. These were very fine stands indeed, worthy of being staged at any show in the kingdom. Mr. Stevens was third. In the classes for twelve and for six incurved blooms Mr. Sullivan took the lead with beautiful stands, Mr. J. Bentley, gardener to Sir T. Gabriel, Bart., being a good second, and Mr. J. Burnett, gardener to Capt. Fenwick, Wimbledon, a close third. Mr. J. Bentley took the prize for the best six blooms of any variety with compact solid examples of Lord Alcester; Mr. Campbell, gardener to Dr. Wood, Wimbledon, following with Queen of England. Mr. Coombs, Mr. Sullivan, and Mr. Stevens were the prizewinners in the order named for twenty-four Japanese varieties, all staging well; for twelve blooms, in which there was great competition, the prizes falling to Messrs. Sullivan, Knowles, and J. Bentley. There were many other classes and excellent competition that we are compelled to pass. In the amateurs' class for twelve incurved Mr. J. Dark, gardener to J. Hooker, Esq., Putney, was first with extremely neat solid blooms; Dr. G. Walker, Wimbledon, being second with larger but somewhat looser examples. Mr. G. Stevens took the lead with twelve reflexed blooms, followed by Messrs. C. Bentley and J. Batten. Mr. Sullivan staged the best Anemone blooms, and Mr. C. Knowles the best Japanese Anemones, Mr. Stevens being a very close second in both classes, and Mr. C. Woodhouse outdistancing other competitors with Pompons.

Wreaths were beautiful, the first prize one, by Mr. Campbell, gardener to Dr. Wood, Roehampton, being the best we have seen made by a gardener, Messrs. Fall and Townsend following closely. Mr. G. Stevens took a distinct lead in bouquets, winning the first prizes in both classes, Messrs. Alderman, Moore, and Knowles also being prizetakers.

Mr. Pitt's prizes for groups of miscellaneous plants were won by Mr. Campbell, gardener to Dr. Wood, Mr. C. Knowles, and Mr. J. Batten. They were somewhat lacking in brightness, and in some the pots were obtrusive. Messrs. Mahood's prizes for vegetables were won by Messrs. Batten and Coombs; the Society's prizes by Messrs. C. Woodhams, Tigwell & Son, and J. Batten with excellent collections. Grapes were fairly represented, the prizes for black going to Messrs. Knowles, Batten, and Richardson; white, C. Bentley, Springthorpe, and J. Bentley. The best kitchen Apples were staged by Mr. Batten, and the best dessert by Mr. J. Bentley.

Mr. G. H. Pitt and Mr. J. Moore, to whom so much credit is due in

the management of the Society, continue their valuable services in the position of Treasurer and Secretary.

#### TWICKENHAM.—NOVEMBER 15TH AND 16TH.

THE autumn Show of the Twickenham Horticultural Society, held in the Town Hall on Tuesday and Wednesday last, was highly satisfactory in all respects, and in quality of exhibits would bear favourable comparison with many other more pretentious shows. The entries were numerous, the total exceeding that of previous years by fifty, a most encouraging advance. The groups of Chrysanthemums were uncommonly good, and all were effectively arranged. Cut blooms were also of considerable merit. Table plants, fruit, and vegetables in competition were well represented, the non-competing exhibits also occupying a large space and possessing more than ordinary merit. The courteous and able Hon. Secretary, Mr. Jas. J. G. Pugh, assisted by Mr. Bates and an experienced practical Committee, arranged the exhibits to the best advantage in the large hall and three smaller rooms of the building, the general effect being exceedingly bright and pleasing.

For a group arranged in a space of 50 square feet there were five entries, T. Twining, Esq. (gardener, Mr. Parsons), winning first honours with a very handsome group, distinguished by the good quality of both Japanese and incurved blooms, the plants also being well disposed. The second place was taken by J. Bigwood, Esq., M.P. (gardener, Mr. Waldie), who had a highly meritorious group of dwarf plants, the blooms fresh and good, but the general appearance was rather flat owing to the plants being of uniform height and placed closely together. T. Lane, Esq. (gardener, Mr. Campin), and Mr. G. Street were third and fourth.

The principal cut bloom class was that for twenty-four, twelve incurved and twelve Japanese, the competition being very keen between J. D. Paul, Esq. (gardener, Mr. Munroe), and W. Furze, Esq. (gardener, Mr. Coombs), the former being very strong in Japanese and the latter in incurved blooms. Mr. Munroe also had some solid fresh incurved blooms, and after careful consideration he was adjudged the first prize. Mr. Davis followed in the third place. Mr. Furze was, however, the chief winner of twelve incurved, excellent neat blooms, Mr. W. Davis and W. Truefitt, Esq. (gardener, Mr. H. E. Lambert), following. In another class for twelve incurved Mr. Munroe took the lead, Col. Costley Murray (gardener, Mr. G. Morrell), and Mr. G. Warne securing the second and third places. Amongst six exhibitors of twelve Japanese Mr. Munroe was again the premier exhibitor with fine fresh blooms, Mr. W. Furze and Mr. Davis again following. For twelve large Anemones and twelve Pompons Mr. W. Furze was easily first, showing admirable blooms, Lady Margaret and Acquisition in the former being remarkably handsome.

The miscellaneous plants comprised some baskets arranged for effect, G. J. Atkins, Esq. (gardener, Mr. T. Buckland), being first, a graceful Palm with Zonal Pelargoniums, Primulas, and Ferns edged with Isolepis. Mr. G. Fittell was a close second. The table plants formed an interesting class, Messrs. Munroe, Street, and Capt. Webb being the prizewinners. Mr. H. Little, Twickenham, showed a group of Tuberos Begonias and Marigolds in pots, which attracted much admiration, and were very highly commended. Mr. Warren of Isleworth had a group of extremely well grown Cyclamens (highly commended), similar recognition being accorded to Mr. J. May, St. Margarets, and Mr. J. Walker of Whitton for groups of Cyclamens, and to Messrs. Hooper & Co. for a most tasteful group of Orchids, Ferns, and other plants. Mr. H. Bray, Richmond, and Mr. W. Brown had interesting floral exhibits, the former bouquets and wreaths, and the latter two bouquets.

With a stand of flowers Mr. G. Fittell was first for a very bright and tasteful arrangement, Mr. W. Brown and Mr. Gardner taking the second and third places. For stands of autumn leaves and berries Mrs. Tindale had the most elegant contribution.

Fruit and vegetables were numerous, Pears and Apples being especially well shown. Mr. G. Garrod had the best four dishes of Pears, excellent even examples of Duchesse d'Angoulême, Baurré Diel, Doyenné Gris, and one like Seckle. Mr. G. Morrell was second, having fine Marie Louise and Glou Morceau, Mr. E. Battle being third, showing large Catillac. Messrs. Garrod, Morrell, and Stroud were the winners in the Apple class, and with four dishes of fruit Mr. Wadham was in the first place, Mr. T. Buckland, Mr. Davenport, being second and third. The collections of vegetables from Messrs. Stroud, Garrod, and Morrell were selected for honours, the second named also having the best Tomatoes. Collections of Apples and Chrysanthemums from Mrs. Meek (gardener, Mr. Bates) were very highly commended, also Apples and vegetables from Mr. W. Mann, Whitton, and from Mr. W. Poupart, including some extraordinarily fine Celery.

#### SHEFFIELD AND HALLAMSHIRE.—NOVEMBER 14TH AND 15TH.

THIS Show was held in the Engineers' Drill Hall, Glossop Road, Sheffield, on Monday and Tuesday last. The exhibitions of the Society have in previous years been confined to members of the Society, but this season it was decided it should be extended, and open classes were provided for twenty-four incurved varieties and twenty-four Japanese, prizes £10, £5, and £2 10s. for each class. In the class for twenty-four incurves there were but three entries, and the first prize was secured by Mr. J. Jellicoe, gardener to F. H. Gossag, Esq., Camp Hill, Woolton, Liverpool, with exceptionally fine blooms, very fresh and even. The second prize was secured by Mr. D. Heany, gardener to H. G. Schintz, Esq., Mossley Hill, Liverpool; third, J. Lambert, gardener to Col. Wingfield, Onslow Hall, Shrewsbury. In the corresponding class for

twenty-four Japanese there were five entries, Mr. Jellicoe again securing first honours with large and fresh blooms. The second prize went to Mr. Hargreaves, gardener to J. P. C. Starkie, Esq., Ashton Hall, Lancaster; Mr. D. Heany being placed third with a good collection, only one or two points inferior to those placed second. The two other exhibitors in this class were Mr. Morton of Mordon Bridge, Darlington, nurseryman, and Mr. James Harrison of 107, Hoole Street, Walkley. Mr. Morton's stands were not placed, there being only three prizes, which is to be regretted, as his flowers were of high quality. The remaining stand of twenty-four Japanese, exhibited by Mr. James Harrison, a Sheffield working grinder, though not quite so large as those last mentioned, were very creditable to the exhibitor, who is closely engaged during the greater part of each working day at his own trade.

All other classes set forth in the schedule excepting the two above described, were limited, as in previous years, to members of the Society. In the classes devoted to cut flowers the principal exhibitors and prizewinners, taking them in the order as named, were Mr. Redmill, gardener to — Lowood, Esq.; Mr. E. Austin, gardener to Mrs. Allcard; Mr. Stimpson, gardener to — Craven, Esq.; Mr. Simmonds and Mr. Whiteley. The Japanese varieties shown in these classes were of much superior quality to the incurved, and were in many cases creditable exhibits.

Groups of Chrysanthemums were much more numerous, and decidedly superior in quality to those shown at any previous exhibition of this Society, the prizewinners being the same as mentioned above for cut flowers. The first prize large group, shown by Mr. Stimpson, consisted for the most part of trained plants, and was very effective. Some good groups of miscellaneous foliage and flowering plants were also shown, and added much to the attractions of the show. In those for competition the first prize went to Mr. Speight, gardener to Mrs. Fawcett; second to Mr. Redmill; third, Mr. E. Austin.

Very fine groups, not for competition, were shown by Mr. Mower, Westbourne Conservatories, and Messrs. Fisher, Son & Sibray. That from the first named was of a very extensive character, filling the greater part of one side of the room, and was brightly coloured with Erias, Solanums, Roman Hyacinths, &c. In the latter group were some good specimen Cypripediums, greenhouse Rhododendrons, foliage plants, and Ferns. Primulas were as usual at the shows of this Society a very fine display. No less than five large groups were staged, and all of superior quality. The first prize was obtained by Mr. T. Marsden, a well-known local grower and prizewinner; second, Mr. Redmill; third, Mr. Simmonds. Some very fine specimens of Epiphyllum truncatum were shown by Mr. Speight, with heads 3 feet across and covered with blooms. Cypripedium insigne was also shown in considerable numbers and some noble specimens, the prizewinners being Mr. Simmonds and Mr. Herriot. The latter exhibitor was also first for three Orchids, with good well-bloomed specimens of Cypripedium insigne, Odontoglossum grande, and Oncidium Forbesii.

There were ten stands of Grapes (two bunches each) exhibited, Mr. Stimpson obtaining first prize in the class for black Grapes with medium-sized well-coloured bunches of Alicante. The white Muscats were not so good an exhibit, but the first prize bunches exhibited by Mr. Watts, Rotherham, were very creditable specimens. The same exhibitor put up, not for competition, a collection of well-grown Apples and Pears. Messrs. Fisher, Son & Sibray also showed, not for competition, about fifty dishes of hardy fruits grown at their Handsworth Nurseries.

The Show was much superior to most previous ones held by this Society, and was well arranged throughout, reflecting much credit upon those officials and members of the Committee upon whom has rested the responsibility and work, and especially upon the Secretary *pro tem.*, Mr. R. Hall, who has been filling the office at a very arduous and difficult time, owing to the unfortunate illness of the Secretary to the Society, Mr. E. Austin.

#### IPSWICH.

THE annual Show of Chrysanthemums, fruit, and vegetables was held at the Corn Exchange on Thursday and Friday last, and was acknowledged to be the best autumn Show the Society has ever had. The groups of Chrysanthemums in pots were arranged in the centre of the hall; on each side of the group were two tables, one being devoted to the cut blooms, the other to fruit, bouquets, baskets of flowers, and table plants. The vegetables were arranged on tables round the walls.

The display of cut blooms was very fine, especially the Japanese, the incurved being small, and some rather rough. The best blooms in Messrs. Saltmarsh & Son's stand of twenty-four were Lord Wolsey, Refulgence, L'Adorable, M. H. Jacotot, Mr. John Laing, and Criterion. Second, Col. Lowe (gardener, W. Danec) with good blooms of J. Delaux, Criterion, L'Adorable, and a good bloom of Madame Audiguier, to which was awarded the silver medal of the National Chrysanthemum Society for best bloom in the Show.

Amateurs, twenty-four varieties, Mr. H. Lister, gardener to Lord Brooke, Eaton Lodge, Dunmow, was first, the best blooms being Queen of England, Empress of India, Novelty, Refugence, Mr. W. Shipman, Thunberg, Madlle. Lacroix, and a large bloom of Triomphe de la rue des Châlets. Second, Mr. C. B. Skinner, with good blooms of Lord Wolsley, Japonaise, M. Marrouel. For twelve incurved, amateurs, the Rev. H. Berner was first with very neat well-finished blooms; the best were Lord Aleester, Jardin des Plantes, and Empress Eugénie, very fine.

#### CHRYSANTHEMUM SHOWS.

THE following are the dates of the principal shows to be held during the coming months, at which Chrysanthemums will be the leading feature:—The figures following the name of the place at which the shows are to be held indicate the number of days devoted to the exhibitions, and it will be seen that a large majority are two-day shows.

#### NOVEMBER.

Thursday, 17th	Bury St. Edmunds (2)	Friday, 18th	Sheffield & West Riding (2)
	Chswick		Reading
	Hull (2)		Chorley (2)
	Barnsley (2)	Saturday, 19th	Ramsbottom
	Taunton	Monday, 21st	Wolverhampton (2)
	Colchester	Wednesday, 23rd	Bedford (2)
	Wimbledon	Friday, 25th	Eccles (2)
	Bolton (2)	Tuesday, 29th	Liverpool (2)

#### DECEMBER.

Thursday, 8th, Alnwick.



#### KITCHEN GARDEN.

**FORCING ASPARAGUS.**—We can never have too much Asparagus. It is therefore desirable that its season be extended as long as possible, and very early forcing will give much satisfaction in this respect. As a rule we begin to cut our forced Asparagus in November, and from then until spring the supply never ceases. It is one of the easiest of all vegetables to force. Good roots will produce plenty of fine heads in a very short time, but our crowns are not so good this year as we have had them, as the hot and dry weather checked growth in summer. They are well matured, however, and that is important, as, no matter how large the roots may be, unless they are well ripened they will not force profitably. No roots are ready for forcing until they are four years old, and they may be forced from then until they are in their teens. Where the roots are growing rather close together one may be lifted here and there for forcing, and where it is intended to remove any beds or plantations they may be lifted now and placed in heat, as the roots are never too old to force; and although they may have to be dug up now, as might be the case in making alterations, they should on no account be thrown away before being forced. Any place with a bottom heat of 85° or 90° and a top heat of 65° will be found suitable for Asparagus forcing. We generally force our winter roots in the bed of a Cucumber pit with a flue underneath it, and they succeed well there. At times when our Cucumber pit was not available we have made up a hotbed and forced Asparagus on this, and the results were equally good. The roots should be placed into their forcing quarters immediately they are lifted, as they soon dry up, and this is very injurious. On whatever kind of bed they may be placed for forcing there should always be a layer of soil under the roots, then pack them on closely and cover with more soil until the crowns are hidden. Water thoroughly afterwards with water heated to 90°, and forcing will begin. From good roots we cut produce from twelve days to fifteen days after putting them in heat, and each supply of roots will yield heads for a fortnight or upwards of three weeks, and fresh supplies must be put in at intervals of this extent where a constant supply is required, but where the roots are not sufficient to keep up continuous forcing some may be put in occasionally to meet special demands.

**SEAKALE.**—The leaves of this do not die as soon as those of Asparagus or Rhubarb, and forcing cannot begin until the crowns are leafless. Our plants will be bare in about another week, and then the first roots will be put in. It is not easily forced in the ground at present, and the best way is to lift the roots. They are very accommodating, and if cut a little near the bottom in lifting them it will not do them any harm. Only well-developed crowns should be lifted to force thus early; fifty or sixty will give abundance of produce. It is impossible to lift Seakale with any soil adhering to the roots, but that does not matter. We find a good way of treating them is to put a quantity of fresh tree leaves in the bottom of a 10-inch pot, then place from six to ten roots in it with the crowns just above the rim, and while one person holds them in this position another puts the soil all round and amongst them. The soil is settled about them by pressing it down and shaking the pot a little; when this is finished they are watered, and then they are ready for forcing. If a large number are potted at once some may be placed in a cool place to be transferred to heat as required. It is always an advantage to have some in stock in times of severe frost or snow. At the time the roots are being lifted a hotbed should be formed in some dark shed or other

place, and as soon as the heat begins to rise in this plunge the pots to the rim in it. In ten days or so the growths will begin to push up, and they must be kept in the dark, as Seakale is not good unless perfectly blanched. After the first watering it rarely requires more, as the condition of the bed keeps the soil moist, and cutting the produce is all the attention it requires after the first operations have been completed. If the pots can be placed on a warm flue in a dark place growth will be produced, but in this case they will require much water, which should always be given at a temperature of 90°. Boxes might be used in the place of pots, and other dark places besides any indicated may be utilised for forcing.

Asparagus, Seakale, and Rhubarb are the three favourite vegetables for winter forcing, but there are a few others of less importance for which there is a demand. Kidney Beans were dealt with in our last notes, and Mustard and Cress come more under the heading of salads than kitchen vegetables, but they are used in both the kitchen and pantry, and as other salads become scarce they will be much valued. They are the easiest and quickest of all to grow. They will be ready for use in ten days after sowing. If a little soil is put into any shallow box, made firm and watered, and the seed sprinkled on the surface, and placed in a temperature of 60°, growth will be rapid and satisfactory. We do not approve of covering the seed at this season, and it is a mistake to keep it too damp. When ready for use the boxes should be moved into a cool dry place. Chicory or Witloef, it matters not which, are useful salads in winter, and with Mustard and Cress and one or other of these no one need ever be deficient of a good salad all the winter. The roots are Carrot-like in their habit of growth, and if dug and treated in all respects like Seakale they will furnish a fine quantity of valuable salading.

#### FRUIT FORCING.

**VINES.**—*Houses of Thin skinned Grapes.*—The heavy and continued falls of rain have saturated the soil and atmosphere, causing Grapes, particularly Black Hamburgs, to damp considerably; even Madresfield Court keeps better, not being liable to suffer from damp to nearly the same extent as Black Hamburgs, and the liability to crack is entirely at an end as soon as the wood and foliage is thoroughly ripened; indeed, Madresfield Court keeps capitally until the end of November, and might possibly be kept until January, but we have not been able to save any as a test, so great is the demand for this Grape. Black Hamburgs, and other thin-skinned Grapes, have been ripened well; the skins may not be thicker, but the flesh is certainly firmer, the berries being particularly rich and sugary, and though ripe early in August are, with Foster's Seedling, keeping wonderfully well. Vines ripening their crops in September are still in foliage, and will bear more moisture at the roots and in the atmosphere than those that have had the Grapes ripe since August; indeed a moderate amount of air moisture is necessary to prevent undue evaporation, the shrinking of the Grapes, it not being so much air moisture as a stagnant atmosphere that is fatal to the keeping of Grapes. Slight heat in the pipes will be required constantly to maintain an equable temperature, but this must not be high, or it will cause the berries to shrivel prematurely, 50° not being exceeded by artificial means, ventilating freely and early in bright weather so as to prevent moisture being condensed by the berries. The outside borders have been protected from rains by shutters or other material, and if inside borders too are covered with straw the Grapes will keep better. Covering the border prevents its cracking, and keeps down moisture likely to arise and prove injurious.

*Houses Cleared of Grapes.*—Directly the Vines are leafless and the Grapes cut attend to the pruning. If the Vines are strong, having stout, short-jointed wood, they may safely be pruned to a couple of eyes. If, however, the base buds are small, and the Vines have not from similar buds in previous years given as large bunches as desired, the laterals may be left a little longer, but it is necessary that a plump, round (not flat), well-developed bud on stout, hard, thoroughly ripened wood be selected for pruning to, aiming at a close compact bunch of well-set berries with a stout footstalk in preference to a large uneven bunch, which usually follow large flat buds on long-jointed wood, the foliage supporting such being large, thin, and incapable of elaborating the food and concentrating it in the buds at their base. Avoid pointed buds, they usually are not productive of bunches, and if they are on long-jointed wood the bunches should have a tendency to revert into tendrils. Wash the house thoroughly, and cleanse the glass. Remove only the loose bark, avoiding the scraping. Tepid soapy water is unquestionably the best means of cleansing the Vines, using a brush with care and judgment, following with an approved insecticide. Remove the mulching or loose surface material down to the roots, and place on a couple or 3 inches thickness of fresh loam, mixed with some old mortar rubbish passed through a three-quarter-inch sieve, night soil, soot, and wood ashes. If the loam be light add some clay marl dried and reduced to powder. Of turfy loam cut 3 inches thick and chopped moderately small have twenty bushels, of sifted old mortar rubbish add two bushels, of night soil mixed with an equal proportion of dry earth one bushel, soot half a bushel, wood ashes one bushel, clay marl (if the loam be light), two bushels, and one bushel of bone meal. Charcoal may be added to the extent of four bushels, together forming a chaldron, when thoroughly incorporated, of dressing for Vine borders, good alike as a rooting and feeding area. The early watering will wash the assimilated matter down to the roots, and fresh feeders encouraged into it can be kept there by surface dressing or mulching with short manure

after the Grapes are set, feeding with liquid as necessary. If the houses must be used for plants they should be kept cool, admitting air freely, not exceeding 40° to 45° by artificial means. It is best, however, to dispense with the plants, admitting air freely in all but very severe weather, a few degrees of frost doing no harm to the Vines, but insuring more complete rest.

*Earliest-forced Vines in Pots.*—The earliest started will now be showing signs of growth, so that the temperature may be slightly increased—55° min. and 66° max. by fire heat, with 10° more from sun heat, proportionately increasing the atmospheric moisture. The ventilation will require to be very moderate, and what is given should be at the top of the house; if side ventilation be employed the cold air should be made to pass the heating surface so as to become warmed, as cold currents of air are extremely pernicious.

**CUCUMBERS.**—Cold sunless weather is very trying, as the continued firing dries the atmosphere more than is good for the foliage, the fruits becoming stunted and swelling indifferently, and when the pipes are close to the roots the soil is dried too much for healthy growth. Be careful in ventilating, providing it, however, whenever a favourable opportunity offers, but exclude it when the external air is sharp and cold. In bright but cold weather turn off the top heat when the sun is powerful and likely to raise the temperature above 80° in such weather, damping the house morning and afternoon, closing early. Care must be taken in damping, so as not to wet the embryo fruits, or they will damp off. Water will be required at the roots about twice a week. A temperature of 60° to 65° at night and 70° to 75° by day is suitable.

The winter fruiterers or plants from the August sowing, and planted out in September, have grown to the extent of the trellis or nearly so. Unless there is undue vigour in the plants they should not be allowed to fruit for a few weeks. Attend frequently to stopping, thinning, and tying the shoots, avoiding overcrowding and overcropping as the two greatest evils, subduing canker at the collar with quicklime well rubbed into the parts affected, removing every decayed leaf promptly. If mildew appear dust with flowers of sulphur, it being well to dust some over the plants with a view to its prevention. Aphides should be destroyed by fumigation with tobacco, being careful not to give an overdose.

**MELONS.**—Except in the latest house these are about over. Our latest Melons have the fruit just beginning to net, and will be ripe some time in December. They need a rather moist genial condition of the atmosphere to insure their swelling, damping the house in the morning and again in the afternoon, putting on a "crack" of air in the early part of the forenoon to insure the dissipation of moisture and induce evaporation from the foliage. The night temperature is 60° to 65°, and 70° to 75° by day artificially, advancing as much as can be had from sun heat after the sun passes the meridian. The plants have liquid manure about once a week. Plants that set their fruit early in September from late July sowings are ripening. They should have air constantly, and a temperature of 70° to 75°, with as much more as can be accorded by day, husbanding the sun heat, but not closing the house, withholding water from the atmosphere and roots. The fruit will ripen and prove acceptable even at Christmas and new year.

#### PLANT HOUSES.

*Ci'anthos.*—The earliest plants will be pushing up their flower spikes rapidly, and great care must be taken in pushing water to the roots. After the first two or three flowers open, or the foliage has all died naturally away, they will need very little water, if any. This depends very much upon the temperature in which they are placed to bring them into flower. If the temperature ranges about 65°, and the atmosphere is moderately dry, they will need sufficient water to keep the pseudo-bulbs fresh and plump. If they are in a temperature 5° lower, with a fair amount of moisture in the atmosphere, they will need no water. Nothing is gained by hurrying them out in strong heat; 60° by night with a rise of a few degrees by day will be ample unless they are needed in flower as early as possible. Later plants should be kept in the same temperature, except those that have been grown purposely for flowering in January; and these must be kept slightly warmer and judiciously watered until they have thoroughly ripened and matured their pseudo-bulbs. The plants still in active growth should be arranged close to the glass, and on the sunny side of the structure, for under the most favourable circumstances it is difficult to mature them sufficiently to insure health and vigour.

*Cattleyas.*—Such species as *C. Trianae* will have completed their growth as far as appearance is concerned. Remove all in this condition to the coolest end of the structure, and admit more air to them than is needed for those in a less forward condition of growth. The atmosphere in this portion of the house should also be kept drier by throwing less water about the floor and amongst the plants. It is difficult to regulate exactly the condition of the atmosphere in this respect, but much can be done if the method pointed out is only carefully carried into effect. Drier conditions generally in this structure will be needed. The syringe should be dispensed with, and less water applied to the roots. Too much water from this date will end in the roots perishing, and if the atmosphere is kept too moist the foliage is liable to be spotted. A night temperature of 60° will be ample, a few degrees more on mild occasions will do no harm. Watch for yellow thrips, which, if once allowed to become established, will cause considerable labour and annoyance, besides injury to the foliage. The conditions of the atmosphere from this time are very favourable for this pest. Directly any are observed dust the parts



attacked with tobacco powder. This should be washed out at intervals of three days, and again applied until they have been eradicated.

*Pendrobium*.—Do not place deciduous species that have matured their pseudo-bulbs and ripened their foliage in a cold draughty house. They will bear without injury the temperature of a cold house provided they are dry at their roots, the atmosphere moderately dry, and the plants are carefully screened from exposure to cold draughts. All that are not hard and well-ripened should not be placed in a lower temperature than 50°. Pseudo-bulbs that are badly ripened and then placed in a cold house are very liable to damp. This can be avoided only by placing them where the atmosphere is moderately dry and a little heat used. Such species as *D. chrysotoxum*, *D. densiflorum*, *D. thyrsoiflorum*, and others of an evergreen nature must not after the completion of their growth be placed in too low a temperature. By such treatment the foliage is certain to be injured and the plants sadly disfigured in consequence. The foliage, if it does not turn yellow towards the extremity while under cold treatment, is certain to do so directly they are returned to heat and moisture. Cold treatment during the period of rest will result in a few years in the plants decreasing in health and vigour. They must not at any time be in a lower temperature than 50°, and even then they should be dry at their roots and protected from cold draughts.

*Cœlogyne cristata*.—This and its varieties that have thoroughly matured their growth may be placed in the Odontoglossum house, or any cool structure where the temperature will not fall below 45°. They should not be syringed over the foliage, and less water will be needed at their roots, but on no account allow them to suffer or shrivel by an insufficient supply. The pseudo-bulbs must be kept fresh and plump.

*Masdevallia tovarensis*.—The Odontoglossum house is too cool for this variety unless the temperature maintained does not fall below 50°, and even then it should occupy the warmest end of the house. Under cool treatment it will go back rapidly if it does not die before the spring. It will increase quickly if given a position at the coolest end of the Cattleya house, unless an intermediate temperature between this and the Odontoglossum house can be afforded.

## THE BEE-KEEPER.

### IN-AND-IN BREEDING.

In most animal life, whenever in-and-in breeding has been continued for a length of time, a great amount of degeneracy takes place, visible often in the first and second generation. Very often precocity is produced, resulting in impaired vitality. The long flight of the bee enables it, however, to avoid to a great extent the possibility of mating with closely related bees.

As is well known I have been taking a deep interest in the Syrian races of bees for various reasons, one of these being a determination to disprove the assertions of those who seem to find no good in them. I have succeeded in my endeavours, and it is not my opinion only, but experience of their gathering in many instances double the quantity of honey that others did in the same time, which enables me to speak with confidence. That the Syrian bees have their faults I will not deny, but most of these are easily overcome after their habits are known.

This year many people asked me for a queen of that race, and to accommodate them I set about to raise queens to supply my friends. For various reasons I bred or rather mated some, removing for that purpose the bees to a place where crossing with other drones would be avoided. In this I was tolerably successful, but owing to this very cause a number remained sterile, it being at all times difficult to get fertilised queens where there are none but closely related drones. At one time I was hopeful that all who had asked for queens would be supplied, but, unfortunately, after these queens had produced a worker they suddenly became drone breeders. Precocity does not show itself in the bee by early breeding, as often the earliest laying queens are the best, and their progeny good workers. In fact any light I can throw upon this important subject is but a conjecture, so must describe only what I witnessed. As I have stated, all the

pure mated queens of this clutch have come to grief through becoming drone breeders immediately after a few hundred workers had been produced, just the opposite to what often takes place with a healthy normal queen. I have had the opportunity of dissecting one only of these queens, and the only portion was the sperm sac and the contents. The appearance of the spermatheca was thin and watery looking, as if some sort of fermentation had taken place. The drones that were produced presented nothing unusual about them. Judging from that I am inclined to think that Nature, abhorring related mating, has so designed that it shall become sterile or partly so.

Whether I am correct or not—and I have presumptive evidence that I am—we see those crossed with alien blood showing extra amount of vigour, and this to a great degree even when the cross is of the same variety. More than once I have sent bees to isolated places for the purpose of crossing, and it has been remarked that the first season showed the improvement in a decided manner.

Most of us have experienced the great advantage of crossing with foreign varieties, but we should be careful to note on the other hand the degeneracy that takes place by in-and-in breeding. Another year I hope to be able to experiment further in this direction. Meanwhile those who have been disappointed in getting Syrian queens from me will know the cause.

### DRONES IN NOVEMBER.

It is not the first time there have been drones in great numbers in my hives at Christmas, and this year appears to be no exception to this phenomenon. It is only two weeks since the majority of drones were killed in all hives unless one still retaining a number. As a rule drones appearing so late indicate a sterile queen, but in this as it was in other cases the queen is in quite a normal state—at least was so several weeks since. A few queries are still lying unanswered, but these will have due attention at an early date.—A LANARKSHIRE BEE-KEEPER.



## TO CORRESPONDENTS

All correspondence should be directed either to "THE EDITOR" or to "THE PUBLISHER." Letters addressed to Dr. Hogg or members of the staff often remain unopened unavoidably. We request that no one will write privately to any of our correspondents, as doing so subjects them to unjustifiable trouble and expense.

Correspondents should not mix up on the same sheet questions relating to Gardening and those on Bee subjects, and should never send more than two or three questions at once. All articles intended for insertion should be written on one side of the paper only. We cannot reply to questions through the post, and we do not undertake to return rejected communications.

*Vines (J. S.)*.—It is not necessary to publish your letter, nor can it be satisfactorily answered in the pressure of preparing for press. It shall, however, have our best attention.

*Staging Chrysanthemum Blooms (A Would-be Exhibitor)*.—As you desire your letter to be answered by Mr. Molyneux it shall be sent to him, and we doubt not he will oblige with a reply.

*Selling Trees (Inquirer)*.—We think that, as a market gardener, you can do what you suggest, but by all means consult a solicitor before signing any agreement.

*Rose-Growing (R. H. C.)*.—Precise information on the subject of your letter can only be obtained by writing to Mr. D. Gilmour, Highbury, Sheffield, and this course we advise you to adopt.

**The Hull Challenge Cup (B. L.).**—You will find from a letter in another column that there is what you term a "deliverance from the dilemma," and it is therefore not necessary to publish your communication.

**Books (Lux).**—"Hardy Florists' Flowers," by Mr. James Douglas, will no doubt give all the information you require. It can be obtained from the author, Great Gearies Gardens, Ilford, Essex. (E. H.).—There are few books of the character you require, and to be successful in growing either plants, flowers, fruits, or vegetables for market a considerable amount of practical experience is needed. You would, however, find some useful hints in Shaw's "London Market Gardens" (London: 37, Southampton Street). Also, if Grapes are to form a part of the trade, obtain Mr. A. F. Barron's "Vines and Vine Culture," published at this office.

**Eucharis (F. F. C.).**—The plants are evidently attacked by the Eucharis mite, but we could only find one or two on the bulbs sent, and they do not appear to be badly infested at present. By all means follow the directions given, and keep the Eucharises away from the Pancratiums.

**Wellingtonia Growths Dying (H. M.).**—The roots sent to us do not suggest that the source of the evil is in the soil. The withered branches present the appearance of being injured by sulphurous acid, and as you say "much smoke and sulphur from the works near pass by and over the tree" that, we believe is the cause of the injury. We are obliged by your letter, and the communication to which you refer will appear in due time.

**Erica mundula (C. M.).**—The woodcut (fig. 54) will give you a better



Fig. 54.—*Erica mundula*.

idea of this Heath than any description. It is a summer-flowering species of neat habit, the branches slender, the flowers in fours, bright red in the centre bordered with white.

**Warts on Hibiscus Roots (C. L.).**—The warted condition of the roots is more marked than usual, and is natural to many plants besides Hibiscus. They are not as a rule detrimental, but are usually most noticeable when the plants are grown in soil containing much organic and especially vegetable matter. Their presence is not due to nematodes, as in the case of many plants that have galled roots, the galls existing as an essential of the plant's economy. It is supposed they act the purpose of storing matter required by the plant. That they have economic value is manifest from their never being absent in the most vigorous examples. The specimen roots sent have every appearance of being healthy, though very much galled. Try baking the soil before it is used; not, however, burning it, but heating in an oven or other place to a temperature of over 212°, striking and growing the plants in that soil. There is no danger, however, at present of the plants falling a prey to nematodes of the description that infest cucumber roots. If you like to try an experiment on your present plants, or some of them, place about a teaspoonful of iron filings on the surface of a 9 inch pot and stir lightly in, watering whenever necessary with a solution of chloride of sodium (salt), half ounce to a gallon of water, then nitrate of potash (saltpetre), also half ounce to a gallon of water, and chloride of lime, also half ounce to a gallon of water, and afterwards with water only as required. We should be obliged if you would in a month send us roots of a plant so treated.

**Scale on Apple Trees (H. H. C.).**—Strong solutions of Gishurst compound, nicotine soap, Fir tree oil, and other insecticides will destroy scale, used as advised by the vendors; so will a strong soap solution and petroleum in equal parts, applied after the leaves fall. We do our best to name fruits from the specimens before us, but both Apples and Pears are influenced by soils, stocks, and position; and it is seldom that the precise conditions under which the specimens are grown are made clear to us, this placing both the growers and ourselves at a disadvantage in endeavouring to ascertain correct names.

**What is an Amateur? (W. F. P.).**—A categorical reply cannot be given to this question. The framers of the schedules of very large shows regard all persons who are not nurserymen as amateurs; but this distinction cannot apply to local shows, in which it is desirable to draw the line between professional gardeners and persons who do not employ them, or only very occasionally to carry out work that is ordered to be done. In such cases an amateur might perhaps be defined as "one who does not make his living by gardening, and does not employ a gardener regularly." This slight altering of your suggestion may possibly meet the case of others who may be in a similar position to yourself.

**Eucharis and Gardenia Culture (Young Gardener).**—The Eucharis are infested with the mite. They will do no good until they are shaken out, the roots washed, and started again in fresh compost. The best plan would be to secure a fresh stock of healthy plants. They do well in a compost of turfy loam rather strong, with a fifth of well-decayed manure intermixed. In potting the bulbs should be covered fully an inch deep. Bottom heat will assist them to make roots, it being 90° at the base of the pots. Gardenias do well in good fibrous peat without any admixture, and will take almost any amount of liquid manure. Eucharis can be flowered twice or oftener in a year by first securing good growth, and when complete affording a rest of about six weeks, then placing the plants in heat, when they will start into flower. When in good condition they flower twice a year without any particular treatment, other than that of growing in a stove with plenty of light and liberal feeding when making fresh growth. The Pelargoniums will not do much good on the back wall of a vinery. Camellias, if you want flowers, would be more suitable. The Roses would be best planted out, making a border for them about 18 inches to 2 feet deep, and providing good drainage. Good loam, with a fourth of well-decayed manure and a sprinkling of crushed bones, would grow them well.

**Preserving the Colours of Leaves (B. T.).**—The following plan is recommended by a lady who has been successful in preserving autumn leaves:—As soon as possible after gathering them the leaves must be pressed. If they begin to wilt or shrivel before you are ready to press them; put them in water and keep them there until they revive. See that no soil, no foreign substance of any kind, is on either side, and then with a warm, not hot, flat iron press and iron each leaf on its upper surface till it is perfectly dry, spreading it for this purpose on several layers of paper, or on an ordinary ironing-board, just as if it were cotton cloth. This over, oil each leaf on the same side on which it was ironed with lard, olive, or lard oil, using a small camel-hair brush or a bit of cotton batting tied to a stick, and then place them on dishes in the sunshine to dry. When dry reject all those that have a semi-transparent or oily appearance; to prevent this get the thickest leaves you can for your collection, and do not oil them too generously nor with a rough brush. It is a mistaken notion that autumn leaves need varnishing. Varnish makes them brittle and more liable to crack, while the excessive lustre that it imparts is unnatural. Oiling gives sufficient polish, deepens, clears, and preserves the colours, and keeps the tissues somewhat elastic. When the leaves get dusty wipe them with a damp cloth; if they curl damp them, and place the branch for a few hours between papers under a pile of heavy books.

**Marechal Niel Rose (R. S. V. P.).**—You do not say whether you intend to grow the Rose under glass or in the open, or whether it is dug from the open ground or established in a pot. A compost formed of five or six parts sound turfy loam, one of manure sufficiently decomposed to mix well with the soil, with a shovelful or two of wood ashes to a bushel of the loam, will grow the Rose well if kept scrupulously free from insects. A quart of bone meal and a little less of soot would still further improve the compost. Roses dug from the ground must be closely pruned. More particulars are necessary for enabling the most suitable treatment to be detailed.

**Heating a Greenhouse (N. E. S.).**—We thought our reply covered every thing. We stated what in our opinion was the easiest, cleanest and most certain method. We have not had experience with the "oil hot-water apparatus" you mention. We have known stoves in houses both fail and succeed according to their capacity for the work, and the aptitude and attention displayed in their management. If your house is a span-roof we have not seen an oil stove that would heat it satisfactorily, nor are we certain you would find one to answer if the house is a lean-to. You give no idea of its height.

**Plants for Rockery (W. R. T.).**—Do not confine your plants to those of a "creeping character," but mingle with them others of a dwarf compact or spreading growth, and the effect will be much more satisfactory. Among those which we find to answer are *Erica carnea*, *Azalea amcena*, *Kalmia nana*, *Erica Foxi*, *Phlox frondosa*, *P. Nelsoni*, *P. verna*, *P. setacea*, *Plumbago Larpentea*, *Thymus lanuginosus*, *Silene maritima*, *Hypericum patulum*, *Lithospermum prostratum*, *Rhododendron ferrugineum*, *Andromeda floribunda*, *A. Catesbaei*, and *Gaultheria procumbens*.

**Lady Downe's Grape Unsatisfactory (Rev. F. F.).**—The specimens sent show a very unsatisfactory condition of the Vine, the berries being very small, badly set, and shrivelled. It is no doubt in consequence of a deficiency of heat in the early stages of growth, defective ventilation, and neglect of fertilisation when in flower. There must also have been a deficiency of nutriment during growth (especially at the time of ripening) and not sufficient heat. To grow Lady Downe's well it should be started not later than early March, and encouraged with gentle fire heat in the spring and early summer. It should be fertilised with Black Hamburgh pollen, maintaining a rather dry heat during the setting of 65° to 75° artificially, 10° to 15° advance from sun heat. In thinning be careful to remove the very small berries only, and early, deferring the general thinning until the berries are the size of peas, when the stoneless ones from their lagging behind are readily distinguished. This Grape is also liable to scald, which usually takes place when the stoning is completed, or about three weeks before changing colour for ripening. Maintaining a temperature of 65° at night and 70° to 75° by day artificially, ventilating early and freely through the day, is effectual in preventing it. The Grapes ought to be thoroughly finished by the middle of September, or at latest by the end of that month, but the highest perfection is attained when the ripening is

attained with sun heat early in September. The Vine is a free grower, and requires liberal supplies of nutriment, mulching, and liquid manure until the colouring is advanced. The shoots should not be stopped less than two joints beyond the show of fruit, better three or four. The sub-laterals should be stopped at the first leaf—i.e., below the bunch, and on a level with or beyond it they may be allowed to extend more, but no more leaves must be allowed to expand than can have full exposure to light. This applies equally to the leaves up to the bunch. After stopping keep them closely pinched to one joint as fresh growth is made. Ventilate freely in the early stages of growth, so as to insure good well developed foliage, and always ventilate early, admitting just a little air to insure a circulation by or before the sun acts powerfully upon the house. Close early with plenty of moisture, and you ought to grow this very best of long-keeping Grapes.

**Palms for Room Decoration (C. B. M.).**—For this purpose the plants should be grown as hard in texture as possible, confining them to comparatively small pots and feeding with liquid manure, soot water imparting a good deep green colour to the leaves. The following succeed well in a greenhouse temperature, but we grow our young plants in a cool stove, so as to get them to a decorative size in as short a time as possible, and they do not suffer when taken into a warm room, but those for halls should be well hardened before removal into the cooler quarters. *Chamaerops excelsa*, *Corypha australis*, *Phœnix reclinata*, *P. tenuis*, *Rhapis flabelliformis*, *Seaforthia elegans*, *Sabal Blackburniana*, *Pritchardia filamentosa*, and *Areca rubra*. Cool stove kinds are *Cocos Weddelliana*, *Dæmonorops Palembangus*, *Areca lutescens*, *Kentia australis*, and *Latania borbonica*; the latter is very useful for warm rooms. The chief cause of the foliage becoming withered at the tips is from their being grown in a warm house, moist, and close, which renders them soft, so that they cannot bear the dry air of rooms.

**Violets in Winter (Mrs. M.).**—It is not difficult to have Violets in winter if the plants are given good treatment in summer, planting out well-rooted runners or suckers in April in rich soil in the open ground, keeping them free of weeds and runners during the summer, mulching before dry weather, or in June, with short manure, and watering in dry weather. They will be fine plants by the end of September, and commencing to flower, when they may be taken up with balls of soil and placed in frames in rich soil or leaf mould, only using the sash lights in case of frost. They cannot have too much air whenever the weather is mild. In severe weather they should have protection over the lights. Good plants in a cool conservatory ought to flower well in boxes or pots in a position close to the glass, but all depends on the previous preparation of the plants. Perhaps the blooms are eaten by slugs. Look for them after dark with a lantern. Fine varieties are—single purple—Wellsiana, Victoria Regina, and Oloratissima. Single white—White Czár and Rawson's White. They are good alike for frames or outdoors. The best Violets, however, for winter are the varieties of Neapolitan—viz., New York, Marie Louise, De Parme, and Comte Brazzi. They are excellent for frames, blooming from September to April inclusive, and are charming grown in pots. We make a practice not to recommend dealers, because it would be unfair to do so. We are always pleased to answer questions on horticultural subjects.

**Names of Fruits.**—The names and addresses of senders of fruit to be named must in all cases be enclosed with the specimens, whether letters referring to the fruit are sent by post or not. The names are not necessarily required for publication, initials sufficing for that. Only six specimens can be named at once, and any beyond that number cannot be preserved. (*James Hiam*).—Red Pear, Beurré Clairgeau; the other resembles Thompson's. Apple not known, certainly not Nonesuch; probably a cider fruit. (*W. A.*).—1, Brown Beurré; 2, Easter Beurré; 3, Beurré Rance. (*J. B. W.*).—*Maréchal de Cour*. (*Joseph Harrison*).—1, London Pippin; 3, Alfriston; 5, Golden Reinette; 6, Golden Pearmain; Nos. 2 and 4 were loose in the basket. (*G. Harris*).—The Apple is Alfriston, and the Pear Hacon's Incomparable. (*W. A.*).—4, Embroidered Pippin; 5, Reinette de Caux. (*A. Mitchell*).—1, Durondeau; 2, Crassane; 3, Beurré Diel. The Apple is Orange Goff. (*E. Fisher*).—1, Brown Beurré; 2, Fondante d'Automne; 3, Beurré Diel; 4, Golden Noble; 5 and 6, Not known; apparently Cider Apples. (*George Swales*).—Lord Lennox. (*N. Pownall*).—The three Pears you sent are not Eyewood, but Doyenné Gris. The other is, as you say, Fondante de Charnéu. What you take to be Conseiller de Cour is not that variety. It is a very inferior sort to that.

**Names of Plants.**—We only undertake to name species of plants, not varieties that have originated from seed and termed florists' flowers. Flowering specimens are necessary of flowering plants, and Fern fronds should bear spores. Specimens should arrive in a fresh state in firm boxes. Slightly damp moss or soft green leaves form the best packing, dry cotton wool the worst. Not more than six specimens can be named at once. (*W. R.*).—*Pholidota imbricata*.

COVENT GARDEN MARKET.—NOVEMBER 16TH.

TRADE very quiet. Prices unaltered.

VEGETABLES.

	s. d.	s. d.		s. d.	s. d.
Artichokes, dozen ..	1 0	2 0	Lettuce, dozen ..	0 9	0 0
Asparagus, bundle ..	0 0	0 0	Mushrooms, punnet ..	0 6	1 0
Beans, Kidney, per lb. ..	0 3	0 0	Mustard and Cress, punt.	0 2	0 6
Beet, Red, dozen ..	1 0	2 0	Onions, bunch ..	0 3	0 6
Broccoli, bundle ..	0 0	0 0	Parsley, dozen bunches	3 0	3 0
Brussels Sprouts, ½ sieve	3 6	4 0	Parsnips, dozen ..	1 0	0 0
Cabbage, dozen ..	1 6	0 0	Potatoes, per cwt. ..	4 0	5 0
Capiscums, per 100 ..	1 6	2 0	"    Kidney, per cwt.	4 0	0 0
Carrots, bunch ..	0 4	0 0	Rhubarb, bundle ..	0 2	0 0
Cauliflowers, dozen ..	3 0	4 0	Salsafy, bundle ..	1 0	1 6
Celery, bundle ..	1 6	2 0	Scorzoneria, bundle ..	1 6	0 0
Coleworts, doz. bunches	2 0	4 0	Seakale, basket ..	0 0	0 0
Cucumbers, each ..	0 4	0 6	Shallots, per lb. ..	0 3	0 0
Endive, dozen ..	1 0	2 0	Spinach, bushel ..	1 6	2 0
Herbs, bunch ..	0 2	0 0	Tomatoes, per lb. ..	0 4	0 6
Leeks, bunch ..	0 8	0 4	Turnips, bunch ..	0 4	0 6

FRUIT.

	d.	s. d.		s. d.	s. d.
Apples, ½ sieve ..	1 6	to 3 6	Oranges, per 100 ..	6 0	to 12 0
Nova Scotia and			Peaches, dozen ..	2 0	6 0
Canada barrel	0 0	0 0	Pears, dozen ..	1 0	1 6
Cherries, ½ sieve ..	0 0	0 0	Pine Apples, English,		
Cobs, 100 lbs. ..	60 0	65 0	per lb. ..	1 6	2 6
Figs, dozen ..	0 0	0 0	Plums, ½ sieve ..	0 0	0 0
Grapes, per lb. ..	0 6	2 6	St. Michael Pines, each	3 0	5 0
Lemons, case ..	10 0	15 0	Strawberries, per lb.	0 0	0 0
Melon, each ..	0 6	1 0			

PLANTS IN POTS.

	s. d.	s. d.		s. d.	s. d.
Aralia Sieboldi, dozen ..	6 0	to 12 0	Fuchsia, dozen ..	6 0	to 9 0
Arborvitæ (golden) dozen	6 0	9 0	Geranium (Ivy), dozen ..	0 0	0 0
"    (common), dozen ..	0 0	0 0	"    Tricolor, dozen ..	0 0	0 0
Asters, dozen pots ..	0 0	0 0	Hydrangea, dozen ..	0 0	0 0
Azalea, dozen ..	0 0	0 0	Lilies Valley, dozen ..	0 0	0 0
Begonias, dozen ..	4 0	9 0	Lilium lancifolium, doz.	0 0	0 0
Capiscums, dozen ..	0 0	0 0	"    longiflorum, doz.	0 0	0 0
Chrysanthemums, dozen	4 0	12 0	Marguerite Daisy, dozen	6 0	12 0
Cineraria, dozen ..	0 0	0 0	Mignonette, dozen ..	3 0	6 0
Dracæna terminalis, doz.	30 0	60 0	Musk, dozen ..	0 0	0 0
"    viridis, dozen ..	12 0	24 0	Myrtles, dozen ..	6 0	12 0
Erica, various, dozen ..	9 0	18 0	Palms, in var., each ..	2 6	21 0
Eunonymus, in var., dozen	6 0	18 0	Pelargoniums, dozen ..	0 0	0 0
Evergreens, in var., dozen	6 0	24 0	"    scarlet, doz.	3 0	9 0
Ferns, in variety, dozen	4 0	18 0	Poinsettia, dozen ..	12 0	15 0
Ficus elastica, each ..	1 6	7 0	Solanum, dozen ..	9 0	12 0
Foliage Plants, var., each	2 0	10 0	Spiræa, dozen ..	0 0	0 0

CUT FLOWERS.

	s. d.	s. d.		s. d.	s. d.
Abutilons, 12 bunches ..	3 0	to 6 0	Lilies, White, 12 bunches	0 0	to 0 0
Anemones, 12 bunches ..	0 0	0 0	"    Orange, 12 bunches	0 0	0 0
Arum Lilies, 12 blooms ..	5 0	8 0	Marguerites, 12 bunches	2 0	6 0
Asters, 12 bunches ..	2 0	6 0	Mignonette, 12 bunches	1 0	3 0
"    French, bunch ..	0 0	0 0	Myosotis, 12 bunches ..	0 0	0 0
Bouvardias, bunch ..	0 6	1 0	Narciss, 12 bunches ..	0 0	0 0
Camellias, blooms ..	2 0	4 0	"    White, English, bch.	0 0	0 0
Carnations, 12 blooms ..	1 0	2 0	Pansies, 12 bunches ..	0 0	0 0
"    12 bunches ..	0 0	0 0	Peas, Sweet, 12 bunches ..	0 0	0 0
Chrysanthemums, 12 bchs.	6 0	12 0	Pelargoniums, 12 trusses	0 9	1 0
"    12 blooms ..	0 6	3 0	"    scarlet, 12 trusses	0 4	0 9
Cornflower, 12 bunches ..	0 0	0 0	Poinsettia, 12 blooms ..	0 0	0 0
Dahlia, 12 bunches ..	0 0	0 0	Primula (single), bunch ..	0 0	0 0
Daisies, 12 bunches ..	2 0	4 0	"    (double), bunch ..	0 9	1 0
Eucharis, dozen ..	4 0	6 0	Polyanthus, 12 bunches ..	0 0	0 0
Gardenias, 12 blooms ..	2 0	5 0	Ranunculus, 12 bunches	0 0	0 0
Gladstols, 12 sprays ..	0 0	0 0	Roses, 12 bunches ..	0 0	0 0
Hyacinths, Roman, 12			"    (Indoor), dozen ..	1 0	1 6
"    sprays ..	0 6	1 6	"    Tea, dozen ..	1 6	8 0
Iris, 12 bunches ..	0 0	0 0	"    red, dozen (French)	1 0	2 0
Lapageria, white, 12			"    yellow ..	0 9	1 6
"    blooms ..	1 6	8 0	Stephanotis, 12 sprays ..	4 0	6 0
Lapageria, coloured, 12			Tropæolum, 12 bunches	0 0	0 0
"    blooms ..	1 0	1 6	Tuberose, 12 blooms ..	0 6	1 0
Lilium longiflorum, 12			Tulips, dozen blooms ..	0 0	0 0
"    blooms ..	6 0	9 0	Violets, 12 bunches ..	1 0	1 6
Lilium lancifolium, 12			"    (French), bunch	1 6	2 0
"    blooms ..	0 0	0 0	"    (Parme), bunch	2 0	4 0



PROGRESS.

To progress in dairy Farming especial attention shall be given in this paper, for it is a matter of primary importance to which more and more attention is given, and concerning which so much has been written that we are under considerable difficulty in making selections from the numerous essays and exhaustive reports of dairy shows which are at hand for reference.

A practical and most satisfactory sign of progress is evident in the systematic management of dairy work, which is generally taking the place of the haphazard practice which so often had unsatisfactory results. Weight, measure, temperature, cleanliness, all receive due attention now, and together they render success a certainty. Really good butter can now be made quickly and well throughout the year, but there can be no question that we get the best butter—best in colour and flavour, when the cows have a full bite of grass. Much may be done by careful stall-feeding, but



when cows milked at 6 A.M., and at once turned out upon pasture, are lying down and contentedly ruminating by 10 A.M., then colour and flavour are at the best. Butter made under such favourable conditions in early summer is undoubtedly excellent, but we prefer that which is made in a genial showery season after the haymaking, when the cows have nothing but the sweet, tender, succulent aftermath. Then is the time to preserve butter for winter use. In France this is done upon a large scale in this way:—To ninety-eight parts of water are added two of lactic acid, and one five-thousandth part of salicylic acid. The lactic acid dissolves the salicylic and prevents its crystallisation. This solution is beaten up with the butter, and it is calculated that about one part of the salicylic acid in ten thousand parts of butter is sufficient to preserve the latter for an indefinite period, even in hot climates. Our readers will find it best to adopt the simpler plan of making up the butter in quantities of 1 or 2 lbs., placed in strong brine under a board kept floating upon the brine so as to insure the complete immersion of the butter. The salt of the brine only penetrates the butter to the depth of a quarter of an inch. Each roll, therefore, is protected by this thickness of a crust of salt butter, all the rest being as perfectly sweet as when first put in.

Reports of the recent Dairy Show at the Agricultural Hall contain much useful information of dairy management, and how the prize butter was made. We give some extracts for the benefit of our readers:—Rev. S. H. Williams, Great Linford Rectory, Newport Pagnell, was very successful, gaining with a single entry in Class 61 not only first prize for best fresh butter very slightly salted, and made from Channel Island cows, but also the Lord Mayor's cup for best butter made in the United Kingdom, and the Association's silver medal for the butter sweetest and in the best condition on the last day of the show. Mr. Williams keeps a small herd of pedigree Jerseys, there being generally from six to eight cows in milk. The cows were at grass night and day, but would be housed at night as soon as the weather breaks up. The extra food consisted of 1½ or 2 lbs. each of cotton cake in the morning, crushed Oats and bran at 4.15 P.M., also a little Clover hay in the rack to eat while the milking is going on. Thyss, Lockyer & Co.'s "Jersey" has been in use since November 1886. Supply of cold water is laid on to the dairy from a well by force pump. The cream rises in from ten to twelve hours. It is only fair to say that during this hot summer not one setting of milk went sour. Hathaway's barrel churn is used. The temperature of the cream when churned is 58°, and cream is churned twice a week. The butter is washed, Bradford's butter worker (Albany) being used. The average price obtained during the year was 1s. 6d., and the demand exceeds the supply. The cows are brought in to calve from August to April, in order to keep a regular and uniform supply during the year.

Of another prizewinner we are told, "The dairy faces the north, and is kept most scrupulously clean. The floor is bricked, and the walls tiled with white glazed tiles. It is fitted with thick green glass shelves on which the tin pans are placed. In summer the cooling tins are used to set the cream, the skim milk being drawn of in twelve hours; but as soon as the cold weather commences the milk is skimmed from the pans, the temperature being from 56° to 60° for churning. Butter is made twice weekly in winter from soured cream, salt being put to it before churning. The butter is never

touched by hand, a Cunningham worker being used. The price obtained per pound to private customers 1s. 9d. all the year round." In another prize dairy the cream is set in shallow Staffordshire pans for thirty-six hours. The churn used is the End Over End. The temperature of the cream when churned is 58°. Sweet cream is used. The number of revolutions of churn is fifty per minute. A circular butter worker is used. Price obtained for butter is 1s. 8d. in winter and 1s. 6d. in summer. The average quantity of butter made weekly is 200 lbs., the demand is greater than the supply. The morning the butter was made, of which a portion was sent to the Dairy Show, the details of the work were as follows:—3 gallons 2 pints of cream; butter, 10 lbs. 14½ ozs.; time of churning, eight minutes: revolutions of churn, fifty per minute; time of making butter, thirty-five minutes.

(To be continued).

#### WORK ON THE HOME FARM.

The work upon our heavy land farm is now in a forward condition, and we shall be able to keep our labour expenses at a much lower weekly sum than we have ever done before. All last winter we had to encounter a heavy outlay on this farm for drainage; this winter little, if any, such work remains to be done. An additional pond has just been made there for a supply of water in summer, in order to avoid a repetition of the costly experience during the recent drought, when we had to cart water daily from a stream some two miles distant from the farm. The work of excavation for the pond in a stiff clay was done for 5½d. per cubic yard, the clay being turned to account to form a dam or raised semi-circular bank at the lower side to hold water and so lessen the work of excavation.

Autumnal work of ploughing and sowing upon the heavy land has been remarkably well done. We have now 150 acres of winter corn sown, and much of it is already up and is a thick strong plant. There are some 70 acres of young layers upon this farm, consisting of Clover, Sainfoin, and Perennial Rye Grass, with about 20 acres besides of old pasture, so that our corn sowing next spring will not be a heavy business, and it will be much helped by the ridge ploughing of all land intended for spring corn. If prices do not improve—and we have no reason as yet to suppose they will do so—more of the heavy land will be laid down next spring in permanent or temporary pasture. Several acres of Lucerne will be sown, and we shall extend the Sainfoin layers very much. The crops of East Anglian farms have hitherto consisted principally of grain, but under the depression a much larger proportion of the land must be brought under forage crops. Sheep will then be kept upon such farms in much larger numbers than heretofore, and the plan will undoubtedly answer, especially if silage takes the place of root crops, which are expensive in cultivation and uncertain in result. All this process of change must be carefully wrought out, for there must be no rash or hasty change leading to heavy expenditure. We know a farmer who has now some 2000 sheep and 200 bullocks, for which he is buying much of the food. Such a plan cannot answer, and we should certainly feel that we ran no inconsiderable risk of bankruptcy under it. To be really self-supporting a farm must produce most of the food given to the animals upon it, unless indeed we can purchase such food at a cheaper rate than we can sell the produce for.

#### METEOROLOGICAL OBSERVATIONS.

CAMDEN SQUARE, LONDON.

Lat. 51° 32' 40" N.; Long. 0° 8' 0" W.; Altitude, 111 feet.

DATE.	9 A.M.					IN THE DAY.				Rain
	Baromet- er at 32 and Sea Level.	Hygrome- ter.		Direction of Wind.	Temp. of soil at 1 foot.	Shade Tem- perature.		Radiation Temperature		
		Dry.	Wet.			Max.	Min.	In sun.	On grass	
1887.										
November.										
Sunday .....	29.375	43.8	42.1	E.	44.9	53.6	40.0	77.2	33.8	—
Monday .....	29.470	43.9	33.0	N.E.	43.3	49.4	39.3	52.7	33.3	0.369
Tuesday .....	29.785	48.5	47.0	N.E.	44.7	52.6	43.8	72.8	41.2	0.192
Wednesday ..	29.947	46.4	46.4	N.E.	45.2	48.3	45.6	50.6	42.4	0.393
Thursday .....	29.836	45.6	45.0	N.	45.8	48.4	45.3	52.2	43.9	0.010
Friday .....	29.986	41.9	41.7	N.	45.8	49.2	40.2	73.7	38.4	—
Saturday .....	30.204	42.1	40.3	N.	45.2	47.8	39.7	71.8	34.9	—
	29.800	44.6	43.6		45.1	49.9	42.0	64.4	33.3	0.967

#### REMARKS.

6th.—Fine, and generally bright, but rather hazy in afternoon.  
7th.—Dull and damp morning, wet afternoon and evening.  
8th.—Overcast early; bright from 10.30 A.M. to about 1.30 P.M., then dull again.  
9th.—Steady, soaking rain all day.  
10th.—Dull morning, dull and damp afternoon.  
11th.—Fair, with a little sunshine, but slightly foggy at times.  
12th.—Fine and generally bright.  
Temperature very equable, and for the first time for several weeks slightly above the average. Rainfall again above the average.—G. J. SYMONS.



## COMING EVENTS

24	TH	
25	F	Eccles and Pontefract Shows.
26	S	
27	SUN	1ST SUNDAY IN ADVENT.
28	M	
29	TU	Liverpool Chrysanthemum Show.
30	W	

## TOMATOES FOR MARKET.

**F**OREIGN fruit is at a discount when well-grown home produce can be had at a reasonable price. Early in the season the former may be in demand, because it can be retailed for less than the wholesale price of English fruit. This will not be the case long, for the increased accommodation that is being provided for the culture of the Tomato will augment the supply, and the price will be lower as a natural consequence. Corrugated fruit is also losing favour. The Large Red and its varieties have too much the appearance of foreign produce, and this may be one of the main reasons the public have against them. Intending growers for market must also bear in mind that large fruits, such as we are in the habit of seeing on the exhibition table, are not appreciated by the public. Purchasers prefer about four fruits to the pound to those that weigh 8 to 12 ozs. each. Sixpence or eightpence seems too much for one Tomato, and they say so freely, while no complaints are made when they get four or five for the same money. What is wanted is a smooth variety of moderate size that will set freely and crop heavily.

Where early fruit is desired the plans for its production should already be matured, and a start made at once. Plants from cuttings are the best for early work, because they are hardier and fruit sooner than those raised from seed. If cuttings can be obtained now they will root readily if inserted singly in small pots and stood on a shelf in a temperature of 60° to 65°. Most of our plants for early fruiting were raised from seed sown near the end of September and kept cool. This method was adopted because we had not cuttings in sufficient quantity of the varieties needed. Seed may be sown at once, and the plants raised will be hardier and in advance of those raised from seed sown in January. They will grow slowly, and should be kept on a shelf where the night temperature ranges about 65°. A strong yet sturdy, and even woody, growth should be induced for early bearing. To insure this they must not be kept too warm, close, or moist: full light is essential, and a free circulation of air. Too much soil must not be provided, nor do Tomatoes need rich mixtures. Any ordinary fertile garden soil that would grow a good crop of Potatoes without manuring will grow Tomatoes well. This year I have seen excellent crops in houses, that were formerly devoted to plants grown on the beds, in 2 or 3 inches of old Melon soil forked into the ashes that filled up the beds, a thin layer of manure being given after the fruit was set. This convinced me that these plants need considerably less soil than is generally given them. A large bulk of rich soil encourages soft growth and only half a crop of fruit. A moderately dry

No. 387.—VOL. XV., THIRD SERIES.

soil and atmosphere will insure firm growth and a good set of fruit. This accomplished, the crop can be pushed forward under warmer, closer, and moister conditions, both in the atmosphere and at the roots. While ripening drier treatment should be resumed.

Some market growers during the past few years have practised a system of pinching the main shoot just beyond each bunch of flowers. This season we tried this method on one side of a house, while those on the opposite side were allowed to grow without pinching. Hackwood Park was the variety tried, and it is one of the best. Nothing was gained by pinching the plants, although a heavy crop can be obtained for half or three parts of the way up the roof. If Tomatoes are grown under suitable conditions and in firm but not rich soil they will produce a bunch of fruit every third joint along the stem. The quickest way of perfecting a crop of fruit is to allow the plants to set five or six bunches of fruit, and then keep them pinched until they are ripe. Although Tomatoes will bear any amount of pruning it is a great mistake to take off much growth at one time, and it tells perhaps more than anything against the flowers setting freely. The easiest and quickest way of managing the plants in this respect is to examine them about three times in a fortnight until they have set the crop that is desired. When this method is practised the knife is not needed, for the leaves and laterals can be pinched with the thumb and finger, without the slightest risk of checking the plants or interfering with their setting.

As to varieties, Orangefield is entirely superseded by Suttons' Earliest of all. It is a dwarf sturdy grower, and carries a heavy crop of well-coloured, moderately sized, rather flat fruits, slightly corrugated, but not to be objectionable for market purposes. It is rightly named, for although it does not commence colouring before Hackwood Park, Mayflower, and some others, it ripens the whole of its crop sooner than any, and for early market work I shall grow it largely in the future. Hackwood Park is the heaviest cropping variety I have grown this year, but a little care is needed in the removal of a few of the first fruits which grow too large and coarse. Acme is a gem for colour, a good cropper, and just the right size for market. Mayflower has produced some beautiful fruit of the right size, but has not cropped quite heavily enough for market purposes. Hathaway's Excelsior is still one of the best, although it does not colour so well as some others, or ripen so quickly, and by allowing the plants to extend freely fruits of the right size can be obtained. Trentham Fillbasket is a great trusser, and colours beautifully. Four or five fruits of this make a pound. This variety appears to be well adapted for growing on the extension system, and by laying in a fair number of the lateral growths a heavy crop of fruit can be obtained.—WM. BARDNEY.

## ROSES AND REVIEWS.

At this time of year, when the horticultural world is gone Chrysanthemum mad, and the queen of flowers hardly obtains a short paragraph, it is satisfactory to meet with the Rose article in the "Quarterly." No other flower, at any rate, that I know of has been thus distinguished, and the article has been written by one who knows well his subject. It might not be difficult to guess at his name; that, however, is not my business. I wish to call attention to the October "Quarterly." The article there is founded on a notice of Rivers' "Rose Guide," 1837; Reynolds Hole's Rose book (10th edition!), and the

No. 2043.—VOL. LXXVII., OLD SERIES.

N.R.S. Catalogue, 1886. The rise of the Rose to its present glory is clearly traced. Rivers started the standard Rose, and a Duke paid £1000 for 1000 plants. The Géant des Batailles came out in 1847. How many of our modern exhibitors ever saw it? yet Rivers sold 8000 plants of it in 1849. He was superseded by Général Jacqueminot in 1853, a superb blood-coloured H.P., which even yet can hold its own. Chas. Lefebvre was given to the world in 1861. He is a prime favourite with the reviewer, who tells a story well worthy of the witty Canon's Rose book, how a mechanic somewhere told him that he had often "run a mile and a half in his dinner hour just to get a peep at 'Charlie,' who was then at his best." 1864 was the great year of all, that gave us Maréchal Niel, a seedling from Isabella Crag, and one most utterly unexpected; "very much," says Canon Hole, "as if a dingy old sparrow had hatched a canary!"

I am glad to see Marie Baumann meets with full appreciation, "the rule of form, more of the perfect than any other Rose." I must admit, however, to have rather failed in allegiance. A. K. Williams to my mind is now the only best and most perfect H.P. Also perhaps the Hybrid Teas hardly meet with the recognition they deserve. Mr. George Paul's Cheshunt Hybrid and the red Gloire Reine Marie Henriette are little likely to be surpassed in their particular department. There is a handsome recognition of Mr. D'Ombraïn's services to the N.R. Society, which he may well be proud of, and with whose name should be joined Mr. Mawley's, who becoming joint Secretary rather later has largely helped to build it up.

One aspiration of the great unknown's all will certainly join in heartily—Oh for "a snow-white Charles Lefebvre, a Mdle. Blanche Marie Baumann, a scarlet Lamarque, and a crimson Maréchal Niel.—A. C.

### THE SETTING, STONING, AND SWELLING OF GRAPES.

Two practical voices have been heard on the subject of the West Lynn Vines, the cultivator and his critic. Would there be any objection now to a word from the theoretical or quasi scientific observer of the West Lynn practice who "gently put" the question upon temperature at flowering time, and who is very much interested in more ways than one in all that concerns successful Vine culture? The difficulties of complete fertilisation and of perfect stoning at West Lynn are not newly developed. Some singular freaks were early exhibited by some Black Hamburgh bunches. The berries were absurdly small, and the stoning abnormally deficient. A very accomplished critic on that occasion laid down two confident propositions, which were these—1, That no berry could develop to a satisfactory size without a proper complement of seeds; and 2, that a sufficient addition of lime would, in this case at least, correct the defective stoning. Lime in great abundance was added at once, and yearly since, without effecting a cure, and Grapes of large size have often enough been found—are, I believe, to be found now—containing only two seeds. Thus it seems that the root of the evil requires to be sought in another direction.

Now it appears to be assumed by some that efficient stoning is synonymous with successful fertilisation, but I have not yet met with sufficient evidence to convince me of this, although some colour is given to the theory—if it be one—by the fact that quite unfertilised berries are always also stoneless. Yet Grapes giving every evidence of successful fertilisation, and as I have said, of good size, are grown with less than their proper complement of stones. On the other hand, the difficulties and defects of fertilisation at West Lynn are so apparent that attention may well be concentrated upon them for the present, whether successful stoning follows their correction or not. The berries here often will not set at all with the ordinary "tap" of the wires, but require a direct application of the pollen. Or, again, a bunch will sometimes set and produce respectable Grapes with the tap only, whilst other bunches which have been more carefully and directly fertilised, from the Hamburgh say, have yielded decidedly better berries.

I, for one, do not at all believe that there is any solution in

questions of soil or plant food. The soil contains naturally all other plant food but lime in great abundance, and clearly lime has been sufficiently added. I can answer for it also that any possible exhaustion has been more than met by a generous supply of all that could be required. That lime is in a sense a liberator of plant food is undoubtedly true; but mineral manures, whether set free by its means or not, are washed away very slowly indeed, though of course the same is not true of nitrogen in any form. Then as regards the mechanical nature of the soil. There are borders at West Lynn of very light, as well as of much more adhesive soil, and some are so constructed as to prevent the possibility of the roots straying beyond them, and there is no difference in the obstinacy of the Grapes to fertilise. That such difficulties should have occurred at all to a cultivator so observant and careful as Mr. Castle, seems to me an indication not only of the unexpected obstacles which all gardeners may expect at some time or other in their pursuit, but probably it is one also of some peculiarity of situation, or other local atmosphere or surrounding, such as that to which our present critic has directed attention by a probably very valuable hint. Such peculiarities as lowness of situation, nearness to the sea, and an area of retentive soil around the vineries may require to be met with differences of temperature and ventilation at a critical time to those usually provided, and may even necessitate some important departures from ordinary routine.

It is to be hoped that an honest and modest confession of occasional and exceptional shortcomings amidst considerable merit, may be the means of benefiting others beside him who has made it.—PROPRIETOR.

[We cannot speak too highly of the manner in which Mr. S. Castle, the manager of the West Lynn Vineries, places facts before the public, whether they are in his favour as a cultivator or not.]

I READ with great interest the article by Mr. Stephen Castle concerning the fertilisation of Grapes, and I think we must look to other sources than lime in some instances to get the desired effect—i.e., the normal quantities of seeds, as on that depends the size the berries will ultimately attain. If we can induce the berries to perfect the proper quantity of seeds it is an easy matter to get the berries to swell to a large size. One seed is not enough, as feed how we will the berries will not attain half the size they would if they contained three or four seeds. A good set is half the battle in Grape-growing, and it is vexing when we see other gardeners, without the least trouble, induce the Grapes under their charge to set properly. In the late vinery here we have the following varieties:—Mrs. Pince, Alicante, and Lady Downe's; but the most surprising part is that with Mrs. Pince, which is considered a shy setter, we do not have the least difficulty; it sets as freely as Black Hamburgh, and the berries have from three to four seeds each. The berries are of good size, the bunches large and compact. Lady Downe's also sets pretty well, but Alicante, which is considered a free setter, we have some difficulty with. It is rarely that the berries have more than one seed, but this is of a good size. Last season we had only one presentable bunch on three rods, in the others the berries being about the size of peas. This year we fertilised every bunch, but even now the result is not so satisfactory as we should like, although the bunches are full, and an ordinary observer would not notice them much. The soil used both for making the border and top-dressing is off the limestone formation in which Rhododendrons will not thrive unless the beds are prepared.—A. YOUNG.

### ON FLOWER GARDENING.

WHAT a glorious season the past has been for out-of-door flowers! We had a cold late spring, and Roses and some other summer flowers were poor and of short duration, but the set-off has been all on the side of plenty. We perhaps have an advantage over many, inasmuch as we grow all kinds of flowers—annual, bedding out of all kinds, florists' flowers and herbaceous plants—always with the proviso that they are in each case free-flowering and effective, and each sort is grown in sufficient quantity to make a good display. Bedding plants are in disfavour in some quarters owing chiefly to the unsuitability of the plants grown. The system I have adopted is to grow only those which are always satisfactory in our own garden, rigidly excluding those of even doubtful effect. The result, in a season like the present, has been complete success. Exactly the same system has been adopted with herbaceous plants, and instead of having the portions of the garden devoted to these bare of flowers, we secure a continuous supply, and an effective display quite as good as, though of a different character from, the bedding plants. Some of the old flowers are still indispensable, but we occasionally obtain novelties



of the first merit, which on trial prove so good that they quite change the features of the garden, and give that change which is thought so much of in these times. Bearing on this matter is distinctness in the planting and arranging of the flowers, no less than in the kind of plants employed. One of the very worst features of present day gardening is the monotony with which the same plants are grown in exactly the same manner in almost every garden, so that one is obliged to be continually on the outlook for something good and novel in order to be somewhat different to one's neighbours. This ought not to be.

Coming now to a review of the plants which have been this year employed most largely, and taking bedding plants first, our two partial failures have been seedling Lobelias and the brown Calceolaria Sir H. Havelock. Both will be set aside for the future. Our most effective plants have been large beds filled with Henry Jacoby Pelargoniums banded with pale blue Ageratum, and finished to the grass with a broad dressed edging of white Königa. A very large bed was prettily filled with large plants of the good old Flower of Spring Geranium set widely apart, and the ground carpeted with light blue Ageratum. This central block was divided from the outside portion by a row of *Dactylis elegantissima*, next to which came a broad line of Mrs. Elliee *Tropæolum*, a beautiful deep orange sort, next to which came the soft-shaded Crystal Palace Gem Pelargonium, and a narrow edging of Königa next the grass. A very nice arrangement in a small bed was composed of a middle block of white Lobelia Princess Royal, dotted with *Chamaepeuce diacantha* and a few red Begonias; the edging next the grass was *Pyrethrum selaginoides*, and behind that the good Wave of Blue Lobelia. The front of a long border was most effective, the plants being a line of *Echeveria secunda glauca* next to the grass, behind that alternate plants of the Lobelia just named and good plants of Golden Chain Pelargonium. Behind these, and growing among them, was Mangles' Variegated Pelargonium, and next to that a broad line of Henry Jacoby. Beds planted in mixture and in juxtaposition with Christine Pelargonium (the best shade of pink we have seen) and yellow Viola mixed, and Bijou Pelargonium and mauve Violas mixed were very pleasing over a long period. Next season we shall have large beds in mixture respectively of Calceolaria Kayi and white Phlox Drummondii, Pelargonium Henry Jacoby and yellow Viola, Pelargonium Christine and mauve Viola, and Pelargonium Bijou and purple Viola, the edging in each case being a broad line of *Cerastium tomentosum*. Mixed beds are always effective when well done. Before leaving this part of the subject it may just be noted that an extremely pretty bed was composed of last winter's flowering Pelargoniums, all the shoots being pegged down, and a few white variegated Pelargoniums dotted in among them.

Coming now to annual flowers, some of these have been surpassingly beautiful. Of such are single Zinnias, which have flowered continuously; Asters, which were finer than usual. The sorts we grew were Victoria—by far the finest—Reid's Quilled, and the new white Pæony Perfection, of which latter two long edging lines were grown. Dwarf Sunflowers were really grand. Salpiglossis, Phlox Drummondii, Gaillardias, the Crimson Flax, were perhaps the best of the others, but most annuals in ordinary cultivation are well worth growing.

Amongst florists' flowers Gladiolus were by far the best. In one border, 120 feet long, we had two lines of plants (about 4 to 6 inches apart in the rows) of the best kinds, with an edging next to the walk of Asters. From the beginning of August till well into September these made a grand show of colour, and were of course, individually, of the very greatest interest. In fact most, if not all, visitors were as much surprised as delighted with their beauty. Pentstemons were not so fine as usual, the dry season being very much against these moisture-loving plants. Phloxes picked up after the rains, but generally these were not a success. Dahlias were very good, Hollyhocks stunted in growth. Pansies we have all but discarded, keeping only a few sorts which do not die off. Antirrhinums have been very good; Pinks and Carnations finer than usual.

The hardy border plants, as a whole, have been finer than in some years. A very large number of the less effective sorts were cleared out last winter, and many more plants of the sorts kept were planted mostly in clumps. Some hundreds of Chrysanthemums were dibbled into the borders in April, and these alone, especially Precocité and Madame Desgrange, which were most largely planted, with some large clumps of Tritomas, made quite a show for many weeks. Tritomas have been really grand this year. We have them in several places, and in all alike they have done well. Clumps of Gladiolus—Gandavensis, Brenchleyensis, ramosus, Ne Plus Ultra, and Lemoine's hybrids—have been very good in the borders. Large numbers of Delphiniums were planted and cut down in order to flower in autumn, but the dry

weather had a bad effect, as few responded to this treatment. It is curious how a few striking flowers, planted in sufficient quantity, give their own individuality to mixed borders. We never saw this so plainly apparent as this autumn, when for weeks the main borders showed a broad mass of orange-scarlet (*Tritoma*) and white (*Chrysanthemum*) with a yellow edging (also *Chrysanthemum*). Looking from either end of the borders the individuality of the hundreds of other flowers then blooming was completely out of sight, and it was only while passing along the walk separating the borders that the other flowers—e.g., Japanese Anemones, various Michaelmas Daisies, Gladiolus, Pansies, Gaillardias, Dahlias, Golden Rods, various early Chrysanthemums, single hardy ditto, Paris Daisies, and such like came under notice. Next season I hope to add to the beauty of these borders by having a couple of hundred of *Aster bessarabicus* to come between the Madame Desgrange Chrysanthemums and the Tritomas. *Solidago canadensis* will also be largely increased—it is such a beautiful and graceful plant. Pentstemons I hope to plant very largely in the front portion of the border, also a greater number of Gaillardias, especially the double Lorenziana. I shall also try a number of Cannas, a few hundreds of Pink Mrs. Sinkins and of Anne Boleyn, and possibly some one or two good annual flowers, and shall expect to tide over, with their help, the period between the break-up of the summer herbaceous plants in July, and the commencement of the autumn display six weeks later.—B.

### VIOLAS.

I WAS delighted to read Mr. Jenkins' remarks on page 402, and frankly apologise if I have in any way disturbed your correspondent's feelings. When a discussion is commenced upon any subject we are all open to criticism, and as I could not find in Mr. Jenkins' quotations any practicable information, I was led to ask how such a description could guide us. I do not think your correspondent need accuse me of any carelessness in reading his communication; on the contrary, I must ask him to withdraw the word "absolute," which he has thought necessary to introduce before exclusion, and which entirely alters the meaning of my quotation. I have not thrown out any insinuations as to the absolute exclusion of any Violas, and if simply quoting your correspondent's own words does not please him, he ought to have thought of it before sending his article to the Journal. I admit that Mr. Jenkins' language is rather difficult to understand. For instance, he says "if I had read his communication rightly I would not attribute to him any desire of absolute exclusion of any Violas;" and further, he says if I were to read his note again, at page 323, I should find that he "merely excludes" those varieties with rounded flowers formally, and refers them to the bedding Pansies; but if Countess of Hopetoun, be a use of its rounded tendency, floriferousness, and dense habit, is an example of your correspondent's judgment, I do not agree with either him or Mr. Dean, as I do not consider these at all essential characters in distinguishing the Viola from the bedding Pansy. Moreover, it is admitted by all florists that these are essential points, equally binding on the Viola and bedding Pansy, and have nothing to do with their classification.

But to return to your correspondent's quotation, "calyx with unequal sepals," I should like to have an explanation of these words, and also I should like to know the difference between the calyx and sepals of the Viola from that of the Pansy. If, as your correspondent says there is no difference botanically, where does he get his authority for asserting that all those with a rounded tendency ought to go to the bedding Pansies? This is certainly not a line of distinction I can support, for the rules laid down for my guidance were—First, colour; second, form; third, size (not too large). Of course, floriferousness, with a dense habit, are essential points either in the bedding Pansy or Viola, especially with those who grow them as decorative plants, but there are others again who grow them for the exhibition table also, and if they cannot find in the Viola the points I refer to, they would certainly never stage these blooms on the grounds of floriferousness or habit. Mr. Jenkins does not see the necessity for such a classification as I ventured to suggest, and thinks the whole might be more conveniently grouped under two heads—viz., Violas and bedding Pansies; and adds, beyond this, if occasion required, they may be grouped to colour, while the miscellaneous varieties may be grouped as fancies. I have no objection to this arrangement, as they would still remain in their respective classes according to my classification, and merely be arranged as the show Pansy—viz., Dark Self, White Self, and Yellow Self; while class 3 in each family would be composed of the miscellaneous varieties spoken of by Mr. Jenkins. Thus, although your correspondent does not admit the necessity of my classification, he is rather inclined to favour my opinion, and I am much obliged for the hint he has thrown out, but he also takes care to remind me that although I take exception to the answer he gives to my question, I do not myself advance anything more obvious. I will, therefore, venture to make another suggestion which I hope Mr. Jenkins will support and help me to carry out.

It is a fact admitted by all florists that a dense well cut blotch is an essential character in all Pansies, whether show, fancy, or bedding; I would, therefore, make this the distinguishing character between the two families, and while we hand over to the bedding Pansies all those with a dense well cut blotch, we would retain all those with pencilled or rayed flowers, as Violas. I have followed this course in my classifica-

tion, and your correspondent will thus see how Archie Grant, Merchiston Castle, and Mrs. Baxter are examples in their respective classes of bedding Pansies, while Pillrig Park, Skylark, and Sejour with their pencilled and rayed flowers are represented as Violas. Mr. Jenkins adds, "Our florists, past and present, have lifted the Pansy to its present standard of perfection, and very naturally laid down hard-and-fast rules for their guidance." Now, this is exactly the point I am aiming at, and if it is necessary to lay down such hard-and-fast rules regarding the Pansy, is it not equally necessary to have some such rules laid down regarding the Viola? for I see no use in dividing them into families if we have no distinguishing character to know the one from the other. "Calyx with unequal sepals" is merely a botanical term equally applied to the Pansy and Viola, and has nothing to do with form or symmetry whatever, hence my reason for asking your correspondent to explain his quotation.—G. STEEL.

### NOTTINGHAMSHIRE APPLES.

IN sending a few Pears for your inspection, I take the liberty of asking for the origin of Ringer Apple. I do so because in housing Ringers and Dominos this autumn I was struck with their family likeness. Indeed, I mixed both kinds together in the barrow as we emptied them out of the baskets from the tree, and it would have puzzled an editor to have picked out rightfully the Ringers and the Dominos respectively and entirely. Domino, I suppose, we shall never now find out the origin of. I have been trying for years to get at it, and have ransacked all the books I could come at, and written numerous letters to various fruit growers, but can get at nothing definite.

Whilst I am writing, I would like to call attention to a circumstance which may, in our locality, cause some confusion in future years as to Bramley's Seedling Apple. About thirteen or fourteen years ago Messrs. Hutchinson & Armitage, seedsmen of Nottingham, sold, from their shop in Victoria Street, young Apple trees under the name of "Best of All." I bought one, as also did a neighbour of mine, and of course many others, and now we find that our Best of All is really Bramley's Seedling. This autumn I have been trying to get at the reason why this Apple was sent out by Messrs. Hutchinson & Armitage under the name of Best of All, but I find they have no reliable record as to the reason. It may be that as they showed specimens of fruits to induce purchasers of trees, that the name may have been thus commercially given as a sort of pushing advertisement notion, Best of All being more sounding and definite than plain Bramley's Seedling. I throw this out as a solving of the difficulty. There is no question, however, about the matter. Best of All Apple, whoever may have it about Nottingham, is really Bramley's Seedling. Mr. Merryweather of Southwell will perhaps confirm this and explain it.—N. H. POWNALL.

[The Apples Domino and Ringer are distinct, the former being more conical than the latter and in use in September, usually decaying in October, Ringer keeping firm till February.]

### HOLLYHOCKS.

I WAS much interested in the notes of your various correspondents in recent issues, and I should have been more pleased had Mr. Boston been able to describe more fully the interest in Hollyhock culture in the neighbourhood of Edinburgh twenty years ago and over. Being located on the south side of the border, his knowledge of that part must necessarily be only partial. I could not but admire an exhibit of Mr. Boston's (Dahlia) which gained a first prize for this year. Looking at them in an ordinary way they seemed to me to be the finest I ever saw exhibited, but I fear success in growing Hollyhocks now seems more a matter of chance or uncertainty. I used to know something of Hollyhock culture in the neighbourhood of Edinburgh twenty-five years ago, but for a number of years, till recently, I had given their culture up. About four years ago I tried a fresh collection to see how they would succeed. The first year they did fairly well, though certainly they showed signs of the "disease," even from the time they came from the vendor. After planting them out in spring, when they began to grow, they were watered every evening with the rose on the can. This they seemed to like, as they made large green leaves, and when flowering time came they did very well. Next winter, however, we lost several of the varieties, and although I had a fine young stock, they were very badly affected with the disease also, so that for the next year I had to fall back on late propagated plants from the old stools. After planting out again, we found by watering them as before helped well to bring the plants on, of course giving water at the root also when required, but in certain weather the disease flourished accordingly. When the weather was hot and dry, I noticed that the leaves were quite covered with the warty specks, and they were altogether of a yellow hue. I cannot help thinking that growing Hollyhocks is now a very risky business, and I feel sure if a number of your readers try it they will give their experience as such.

It will be found that some varieties do better than others—that is, as a rule, they seem to keep freer from the disease—the same as some varieties of Potatoes from the Potato disease. Two of the finest kinds in this respect that I have grown are Cygnet and Rev. D. Paul. I may just mention that recently, about this time of year, I had fine young plants in a cold frame, but before spring only a very few existed owing to the disease. The cold frame might have been too close and damp. This year, out of about a dozen strong seedlings planted last spring, two proved to be very good—one a white, quite equal to, if not better than

Cygnet. All these seedlings had scarcely any disease on them. So if select seed was sown in summer, and good strong plants obtained before winter, it might be a very good way to get some good spikes of Hollyhocks. A neighbour of ours, who has a fine heavy soil; though he has poorer varieties, the plants make a vigorous growth, with scarcely a trace of disease, so that much apparently depends upon the soil. In our case, with every attention, success seems a matter of uncertainty, with little or no prospect of getting up to the pitch of twenty years ago: above referred to.—R. M.

### THE SOIL.

[A paper read before the Paxton Society, Wakefield, October 29th, by Mr D. Gilmour, jun.]

(Continued from page 427.)

THERE is no doubt that the first step in the improvement of soils is to get rid of the superfluous water and to let it in the air. The only way to do this is by means of draining. Many people think that the only advantage of draining is in the removal of the water; but there is a great deal more in it than that, for it will be readily understood that when the water is drawn away from below the air must follow and take its place. Put some stones in a bucket of water, and while the water remains the air cannot get access to the stones; but knock a hole in the bottom of the bucket, and the result is that as the water runs away it will be replaced by air. The same process is going on continually in a well-drained soil.

On undrained land the rains that fall run away over the surface without benefiting it in any way. This was brought very prominently to my notice this summer. A tennis ground, the surface of which had become hard and baked like a brick, adjoins a piece of garden ground which had been well drained and hoed to keep a fine tilth, and prevent evaporation. A few hours' heavy rain came, and while the water ran off the tennis ground in streams, doing little or no good—for it was as dry and hard as ever after the sun had shone on it for a few hours—the garden ground took up and absorbed every drop of the rain that fell upon it, and a subsequent examination proved that the water had penetrated some depth into it.

If we place a kettle of water on the fire, and allow the water to boil away in steam, we can see that a great amount of heat is required to do it. Before the sun can warm a soil the excess of water has to be converted into vapour and dried out of it, and the heat of the sun is thus wasted on undrained land. A well drained dry soil will absorb the heat of the sun to a much greater extent than could be imagined. Sir John Herschel observed that at the Cape of Good Hope the soil attained a temperature of 150° Fahr., when that of the air was only 120°, and no doubt this applies equally to our more temperate climate.

The removal of water by draining changes the character of a soil; a wet heavy clay, naturally cold, close, and adhesive, when dried by this means becoming open and mellow, and thus more easily and cheaply worked. The wonderful chemistry of the soil, which results in the changing of manure and organic matter into plant food, can only go on in a very slow and imperfect manner in the presence of standing or stagnant water on undrained land; therefore manure is, to a great extent, wasted. The rain which falls on the soil is rich in ammonia (valued at £100 a ton), which it brings down, together with oxygen and carbonic acid, from the clouds. This rain, if allowed to run away from the surface of undrained land, as I said before, does not benefit it. On the other hand, falling on well drained land, it sinks where it falls, imparting its fertilising properties to the land, and as it sinks down drawing after it fresh supplies of air from the atmosphere, which are of so much benefit.

There are other reasons in favour of draining, but I think I may pass on to another way in which we improve the soil. This is by digging and forking it, and the chief advantage of so doing is that we open it up and allow the water and air to pass through and penetrate into the interior of it. We also present a fresh surface to the action of the atmosphere. If we examine a sample of soil with a microscope we shall find it to a great extent composed of small pieces of stone. The oxygen of the atmosphere acts upon the surfaces of these small stones just as it does in the case of the large rocks and stones in buildings. When we dig our soil deeply and throw it up in ridges for the winter weather to act upon it, the benefit we derive from the practice is due to the fact that by this means the tiny fragments of rock are made to give up the mineral matter they contain for the use of the following crop.

Now we come to the consideration of those things that we can add to the soil to improve it. If our soil is light and sandy the very best application we can make to it is clay, and the more we put on the better; but it is of very little use to bury it in the ground in great lumps, the better plan is to strew it on the surface, where the frosts of winter can break it up, or the heat of summer dry it, when it may be easily broken up into powder; then dig it in. If the soil is heavy, cold, and binding we should procure road scrapings, sand, small gravel, wood ashes, straw, and decaying vegetable matter of any kind, all of which will help to make it lighter and more open. I do not think ashes are good to add to the soil. I once saw a Rose tree dug up with the larger roots nearly eaten through by them, and as they are known to pierce gas and water pipes I think we are better without them.

There is one very important element which I think is very much neglected in gardens, and that is lime. Now, so long as manure is used freely, so long as land is kept in good heart, there is no danger of lime doing any harm. On the contrary, there is, as far as I know, no such

friend to the farmer and gardener as this. It would be utterly impossible to describe, in a short paper like this, the many ways in which it assists us. I will just mention four. First, by supplying the lime that plants require as part of their food. Secondly, by combining with acids in the soil so as to remove the sourness therefrom. Thirdly, by turning the manure and vegetable matter into plant food; and fourth, by acting on the mineral matter in the soil so as to fit it for entering into the roots of plants. Someone may say, "I have limed my land once, so that it does not require it again." He is wrong for three reasons—because the crops remove a portion of it, because it sinks into the lower soil out of reach of spade or plough, and because the rains wash it away and dissolve it out of the soil. Where soil already contains sufficient lime it is waste of time and money to apply it. Have we a light sandy soil to contend with? Then lime in a mild state will make it firmer, and consolidate it. Or is our soil a heavy clay, then quicklime will open it up and make it easier to work. Have we an old garden where the soil is full of manure, then lime will turn the manure into plant food and give us luxuriant crops.

There is a manure we can all readily obtain, I allude to the sewage and waste water from our own houses. I suppose there is as much manure going down our rivers continually as would support the whole population if put on the land, while enormous sums are spent in the purchase of guano, bones, &c., to replace what we actually throw away. Not only are our rivers thus converted into open sewers, but the loss to the nation amounts to many millions annually. Now, even supposing that it cost the nation the full value of this manure to collect and distribute it on the land, the nation would still be the gainer to an enormous extent, as there is a very great difference between paying away money as wages and throwing it into the sea. However, as far as we personally are concerned, all we need do is to procure an earth closet, or other similar contrivance, or a tank somewhere in the garden, and this done we immediately come into possession of a quantity of most valuable manure free of cost. To give an idea of how green crops relish sewage, Mr. Hope of Barking has produced ten crops of Rye Grass, of 9 to 10 tons each, in a single year.

Another very valuable manure we have free of cost is the waste vegetable matter in our gardens—cabbage stalks, grass clippings, Potato tops, and similar stuff. These should be buried at once in the ground, where they immediately begin to decay, and in so doing yield up a quantity of carbonic acid and other matters so necessary in a soil. Never burn any kind of vegetable matter except wood and weeds, and not these latter except they have run to seed. The objection of burying wood in the soil is that it is apt to produce fungus, when it becomes difficult to get rid of it.

Good farmyard manure may be safely applied to any kind of soil, but for those which are light and sandy, cow manure is preferable, as it retains water for a much greater length of time, while horse manure is more applicable to heavy cold land for the very opposite reason, because it heats quickly and so dries and warms the soil. The sooner manure is buried in the soil the better, provided the land is retentive or heavy; on light soils where the rains quickly wash the essence of the manure away it should be applied only a short time before the crops require it. I may say that the presence of lime in a soil assists very much to fix and hold the manure therein until the crops require it. Where we have to keep or hold over the manure we should take care that the rains that fall are not allowed to soak through the heap and thus convey away the best and most valuable constituents of it. This may be prevented by having the heap under a shed, or nearly as well, by making the heap in the shape of a ridge, off which the rain will run without penetrating into the interior.

Bones are one of the most valuable manures we possess. Where we plant a Rose or shrub to stand for some years a handful or two of half-inch bones will assist it for a considerable time. Where we grow vegetables too, a good dressing of bone sawings will not be lost. Where we wish to assist an old plant or shrub, or a plant in a pot where it is not possible to repot it, few things are better than a top-dressing of dissolved bones. Mineral phosphate is now procured in various parts of the world, and when ground into fine powder is very similar in its action to bones, while at the same time it is very much cheaper.

Fish manure is said to be rich in phosphates and ammonia, and as potash is added, it should be a very valuable manure. I spoke of ammonia as being valued at £100 per ton. This material exists in the atmosphere in the form of nitrogen, the latter forming four-fifths of the air we breathe. Water readily absorbs it, and this is one reason why the rain is so much more refreshing to plant life than any artificial watering. Ammonia is produced largely during the decomposition of animal or vegetable refuse; it is then absorbed by water, in which state plants can take it up by means of their roots. It acts principally as a stimulant, in this way enabling plants to which it is applied to absorb and make use of the other manures which may be within reach to a greater extent than would otherwise be the case. It has been found that where ammonia has been intelligently applied to crops it has produced a luxuriant growth and a proportionately greater return. The ammonia is for the most part contained in the liquid parts of the droppings of animals, which are very often unfortunately allowed to run to waste. Ammonia can be had in various forms—as nitrate of soda, sulphate of ammonia, carbonate of ammonia, and nitrate of potash; but perhaps the easiest way to procure it is to obtain fresh horse droppings from the stables and place them in water. If used in any of the forms first mentioned it must be handled with care, as it is extremely easy to do a pound's worth of damage with sixpenny worth of ammonia. Remember that a small

quantity applied at intervals is better and safer than more put on at one time; indeed this is the case with all manures, an even constant supply of plant food being far better for plants than a feast followed by a famine, or something like it. Soot is a very valuable manure, principally because it contains ammonia.

In conclusion, if we wish to get the full value from the soil, while at the same time retaining it in its most fertile state, we must keep two points in view—first, we must by our method of working it, digging deep, draining, and getting the air down into it, make use of and set free all the mineral matters and manures present therein; and second, we must take care to add to it whatever it is deficient in, whether it be clay, lime, or anything else. If we do this, and keep on persevering, we must eventually succeed. Lord Lytton in one of his plays says, "In the bright lexicon of youth there is no such word as fail." We cannot all be young again; we cannot all be, perhaps, as successful as we wish. "It is not in mortals to command success," but there is nothing to prevent their deserving it.

## GRAPES FOR QUALITY.

I SHOULD like to ask some of your correspondents to devote a chapter to the best flavoured Grapes, black and white. Those who grow for quality have fewer varieties to select from of good appearance to show or supply the table than those who do the same with Grapes of good appearance, but not of the highest quality. At most of the September shows we see plenty of thick skinned showy Grapes making up collections, most of them easily grown sorts. I see it hinted in your last week's issue of something good likely to come in the way of a Black Muscat. I hope it will be the case, as we have not one yet with a vigorous constitution and easily finished. No one can say Muscat Hamburg has a good constitution. Some writers advise inarching it, and others say it does no good that way. I have inarched it this year on Muscat of Alexandria, and the wood is thicker and the eyes more prominent than on its own roots. I have done the same with Mrs. Pince with the same result. The latter is much more easily managed than the former, although it is as seldom seen quite black. As to the relative position of the two while growing, my experience leads me to the conclusion that Mrs. Pince does well with Muscat treatment, while Muscat Hamburg does best in a cooler house, which means do not force it hard. By this treatment I had the bunches this year of 3 lbs. weight and perfectly black. White Frontignan is scarcely ever mentioned in these days of large-berried sorts. Will someone take it up and some others of the best flavour until we have a second Muscat of Alexandria?—T. S.

## JUDGING HAND BOUQUETS.

AT nearly every horticultural show a class is provided for hand bouquets. When well represented they are a very pleasing feature of the show, and take a good share of the attention of the lady visitors. A hand bouquet of medium size, good shape, and a pleasing combination of colours lightly arranged, is, in my opinion, spoiled if the Fern fronds are merely placed among the flowers after arrival at the show. However elegant a bouquet of this description may appear, I think it ought to be passed by the judges, and preference given to others more firmly made, even if they are not quite as elegant in appearance. I have seen bouquets made in this flimsy manner receive prizes at shows in preference to others well and firmly made. Surely the judges had not examined them all very closely, or they would have seen the faulty manner in which the bouquets were made. Such a bouquet is of no use to a lady, for unless she carried it in one position she would soon find that the greenery which gave it such a dainty appearance was vanishing bit by bit. If a gardener sent in a bouquet to the lady made in the way I have described, I fancy he would be requested to construct the next on a different principle. I will here give a few rules from an article written on hand bouquets by Mr. J. Robson, which appeared in the Journal of March 23rd, 1871. He says:—

I.—A hand bouquet must be made so as to be easily carried in all positions in the hand without any of its parts being disarranged when it is turned upside down, and to prove this the judge to be at liberty to swing it sharply about in all directions in his hand, and if it will not bear this ordeal reject it.

II.—The bouquet to be shown without any paper or other guard or bordering except that of flower or foliage, the handle also not to be too thick for reasons given in rule I.

III.—No flower having a disagreeable smell to be used for a hand bouquet; where such exists the bouquet to be disqualified.

IV.—The quality of the flowers used—*i.e.*, their rarity not to be taken into consideration unless the arrangement be equally good or better than where common ones are used.

V.—No bouquet to be exhibited under a glass shade unless all are provided with this appendage, but the exhibitor may be allowed to keep one over his bouquet until requested to remove it prior to judging, not afterwards.

VI.—Dried and Everlasting Flowers not to be mixed with fresh ones, and the same may be said of foliage.

VII.—Flowers may be mounted on wire or other substance, but too



much wirework ought not to be used so as to indicate its presence by the weight of the bouquet.

It is a long time since the above simple but sensible rules were penned by Mr. Robson, but I think they, or some others, want bringing to the front again, for bouquets, like all other exhibits, should have few, if any, flaws in them to take leading positions.—G. GARNER, *Amberwood Gardens, Hants.*

## LONDON'S LESSER OPEN SPACES—THEIR TREES AND PLANTS.

NEW SERIES.—No. 5.

TRAVELLERS upon those lines of railway which converge towards London Bridge from suburban Surrey are familiar with the uninviting district over which they pass to reach the metropolis after they have left New Cross. Rotherhithe, Bermondsey, Horselydown, it is impossible to think these attractive on a hasty survey from above, but coming nearer, if there be some things that repel there is also much that is of interest. It is hereabout, for instance, that some of the early experiments in market gardening were made by the Flemings, who having land in Kent worked their way towards London. Explorations made below the surface in some places have brought to view masses of peat, confirming the tradition that anciently there was a large forest at Bermondsey, but as it laid low there were marshy tracts amongst the trees. Some of the Oaks and Hazels, indeed, were dug out with the nuts attached to the boughs, these species now are scarcely to be found in the neighbourhood. A few years ago there was a newspaper controversy about a spot called Jacob's Island, which some persons argued could not possibly have been surrounded by water in human history, but evidence was adduced to show that there were streams near the old abbey down to the sixteenth century. Much of the ground is still very moist, hence the prevalence of fogs, yet it is admirably suited for the culture of some vegetables, which are in steady demand, as foreign competition has not touched these. Like many other districts this would be much improved if some kindly disposed individuals were to have planted on its open places and roads such trees as would be likely to flourish, and so replace those which have been either cut down or died off, for Bermondsey once rejoiced in a shady park attached to its abbey, incredible as this may appear.

Horselydown, however, is higher ground; formerly a grazing place for horses, it has now ceased to be "downy," vegetation is scant, yet it is not all bricks and mortar, and old names linger telling of the past, such as "Snow's Fields" and "Potter's Fields." Then there is Maze Place, reminding us of the green maze that was attached to the old manor house; it is overlooked by Planes which extend along one side of Guy's Hospital, and which, struggling upwards for light and air, have made themselves tall and seraggy. Close by, encircled by high walls, is the now disused burial ground of the hospital, which the Metropolitan Public Gardens Association has been endeavouring to get opened to the public as a recreation ground. It is not, I fear, a promising spot for flower culture, but it might be planted with some shrubs. The principal open space available at present in Horselydown is the churchyard of St. John's of about two acres, which has been laid out as a garden for some years. Such places are apt to be a little dreary in autumn while the leaves are falling, especially if the bedding plants have been suffered to remain until the early frosts seize upon them. I regret to notice that this is rather a common practice, especially when the plants after they are taken up are distributed amongst the poor, who thus receive them, or a part at least, in a half-dead condition; and it is deemed, I suppose, a wise precaution to place the beds in grass plots, which are railed off from approach, allowing them only to be looked at from a distance, but it appears to me that this is not the way to popularise these open spaces. At least, as there is always a caretaker about there cannot be much danger in letting both adults and children walk amongst beds chiefly planted with shrubs. I still hope for the day when in some of these open spaces there will be given simple lectures on botany, with illustrations, for the public benefit.

In the garden of St. John's, Horselydown, there are not many trees; those recently planted are chiefly Planes, the older ones being Poplars, which have attained a goodly size, as the soil is suitable. One Plane, probably about thirty years old, is conspicuous on account of the curiously contorted growth of trunk and branches. There are a few Scotch Elms of moderate dimensions; this species is not one frequent about London suburbs, and the Weeping Ash appears a tree not to be encouraged in such gardens, for it does not favour the growth of its neighbours of smaller size. Here is a variety of evergreens, but only a part seem to flourish, the smaller leaved, such as the Privet, Box, and Thuia doing best. Yuccas have been placed here and there amongst the tall shrubs, and grow fairly well. Dahlias and Chrysanthemums are amongst the autumn flowers, and Stocks, with patches of Mignonette, linger on in bloom till November. Annuals, however, are not usually of much good in these gardens unless sown very freely indeed.

The parish church of St. Mary Magdalene, Bermondsey, has a churchyard converted into a garden of about 1½ acres; contiguous is the private garden of the parsonage, which can be viewed, but not walked in, by the public, as it is in a rather lower level. We are on historic ground here, for all about are memories of the great abbey at Bermondsey, with its base ground, its long walk, its farm, its park—and, what is oddest of all, its island! Yet there is every reason for believing that "Jacob's Island" was actually at one time what its name implies. A branch of the Thames flowed almost to the walls of the old abbey, and forking,

made this island in its course. It was the abode of the Cluniac monks. At the Reformation Sir Thomas Pope built a mansion on the spot, and cut down most of the ancient trees, but some survived, as indicated by the name "Three Oak Lane," yet remaining in Bermondsey; and possibly "Vine Street" may be a memorial of an old vineyard, though Vines are scarce now in this region. Grange Walk, however, was tree-shaded in the recollection of some old inhabitants. A tavern sign of the "Hand and Marigold," and "Marigold Lane" beside it, are suggestive. Was this flower largely cultivated in the gardens once attached to the Elizabethan mansion? Or it may have been that on some of the land that was neglected a crop of the Ox-eye Daisy sprung up, this humble relative of the Chrysanthemum being often called Marigold by our ancestors, and distinguished by them from the Marsh Marigold, or "Winking Mary-bud" (*Caltha palustris*). Garden Marigolds of several varieties are growing now in the churchyard of St. Mary, appropriate to the name.

But as to trees, the finest to be found hereabout are the four Eastern Planes of this churchyard, indeed there are few handsomer trees in south London, though it is difficult to surmise what is their age. It also contains some rugged Elms, which may have braved the elements and the Scythian beetle for a century, and Poplars old and young, with one Birch at least, as the gardener remarked, to hint to the juveniles that they often desire castigation with its twigs. There are old Elders that must have been planted when this spot was a burial ground, and the species was thought fitting for such places, accompanied by the Laurel as symbolic of victory amongst our forefathers. Many evergreens have been set since without regard to folk lore and tradition, and the method has been adopted of forming groups of one kind, or circle, which makes the different species more conspicuous than when they are mingled at random. Amongst the plants of the flower beds my attention was called by the gardener to specimens of *Weigela rosea* which had proved a success, and he had been growing, as an experiment that old "herb of health," the Tansy; of the herbaceous plants *Antirrhinums* linger on to join the Asters and the Chrysanthemums.

In the churchyard of St. James's, Bermondsey, which is no great distance from the preceding, trees and plants grow more vigorously, for the atmosphere around is purer, and the expanse of Southwark Park is not far off. This is a space of nearly two acres recently transformed from churchyard into a garden, with lines of Elms, Limes, and Poplars; there are also a few Sycamores, that is not a species so familiar in London gardens as the somewhat similar Plane. Here I found growing the Guelder Rose, formerly a great favourite about London; its relative, the Wayfaring Tree (*Viburnum Lantana*) might be introduced with advantage, as the berries and leaves make a show in autumn.—J. R. S. C.



ROYAL HORTICULTURAL SOCIETY.—At the meeting of the Council of this Society on the 8th instant, an informal offer from the Royal Commissioners of the 1851 Exhibition, to let the gardens and conservatory at South Kensington to the Society at a "guaranteed" rent of £1000 a year was discussed. The Council felt that on financial grounds it was impossible for them to accept the offer, as the cost of maintenance, with rates and taxes, would amount to at least another £1000, making an expenditure of £2000 a year for South Kensington alone, without counting office charges or the cost of Chiswick Gardens. It was also decided that no advantage could accrue to the Society from the continuance of negotiations of which the end could only be delay and disappointment. The Council decided to issue forthwith an appeal on behalf of the Society to the horticultural public of the kingdom. The terms and conditions of this appeal were discussed and settled generally. Subsequent to the meeting Colonel R. Trevor Clarke and Major F. Mason resigned their places on the Council, and Mr. William Haughton gave notice that he should resign at the end of the year; these gentlemen having been in favour of continuing the connection of the Society with South Kensington and the Royal Commissioners of the 1851 Exhibition. The Council will not take any steps to fill these vacancies without consulting the Fellows. [We applaud this decision, and have no doubt that good will arise to the Society now that the Council have adopted a definite policy.]

— THE WEATHER has been changeable during the past week, but severe frosts have been experienced in some districts, the records ranging from 12° to 18° of frost on the eastern side of England. Sleet, snow, and rain have fallen on several days, and in the neighbourhood of London fogs have been almost continuous. The frost was

especially keen on Thursday morning, and at Colchester a number of valuable Ferns and fine-foliage plants were greatly injured when being conveyed to the show. The day proved an exceptionally brilliant one, seven hours of sunshine being recorded at one place in the south of England.

— THE second part of Messrs. J. Veitch & Sons' "MANUAL OF ORCHIDACEOUS PLANTS" is just to hand, but owing to the numerous show reports this week we are compelled to withhold a full notice of this important work until another issue. The part is devoted to the genera *Cattleya* and *Lælia*, with such allied genera as *Læliopsis*, *Tetramicra*, *Schomburgkia*, and *Sophranitis*, of which it treats exhaustively both in descriptive and cultural details. It is a valuable addition to the list of authoritative works on Orchids, and is liberally illustrated with wood engravings.

— A CORRESPONDENT who has had much experience as an exhibitor and committeeman writes:—"I have read many articles on EXHIBITORS AND EXHIBITING, but never read one so clear and to the point as that by 'Experientia docet.' Every word he writes is true to the letter. There remains abundant room for forbearance from all parties concerned in flower shows—committees, judges, and exhibitors; and committees and judges should remember that they, as well as exhibitors, are fallible."

— A CORRESPONDENT writes as follows respecting the GARDENERS' ORPHAN FUND:—"I am having a box made similar to a child's money box, about 15 inches long, 5 inches wide and deep, with a slit in the top that will take a penny, and it is furnished with a lock and key. This has printed in large letters on the front of it, "Gardeners' Orphan Fund." It will be hung up in a conspicuous place in my office, where tradesmen and others have to come to do their business, as I thought the hint might be worth copying."

— "W. G. D.," writes:—"Can any of your readers inform me of the difference between CARNATIONS *MRS. GEO. HAWTREY* and *PRIDE OF PENSURST*? I believe the former was sent out five or six years ago by Mr. Turner of Slough, who, in the first place, procured it from a florist of Sidmouth (Devon). Two years ago I bought rather extensively *Pride of Penshurst*, and a comparison of the two convinces me that they are identical. Other growers report the same. If such be the case, in fairness to the raiser and introducer of '*Mrs. Geo. Hawtreay*,' this name should it be known by, and not the adopted '*Pride of Penshurst*.'"

— "C. V. R.," writes respecting *CHRYSANTHEMUM MADAME DESGRANGE*:—"Would some reader kindly say what other varieties there are that associate well with the above, both as to height and colour, to form a bed?"

— LEEK SHOW AND COMPETITION.—In reference to this Show we extract the following note from the *Kelso Chronicle*: "Messrs. Stuart & Mein offered a few months ago the handsome prize of £5 for the best six specimens of the Lyon Leek grown from seed supplied directly by them. A Show and competition took place within their premises in Wood Market recently, and it was largely patronised. The competition was conducted on the same lines as the Cabbage Show held recently, and was open to all without fee or entry money, a card being sent with a packet of seed to all who signify their intention of entering the lists. Exhibits were forwarded from various districts south of Perthshire as far as the Isle of Wight. Thirty-four competitors sent specimens for show, almost the whole of which were remarkably fine and of great merit. Notwithstanding the wide area represented, however, the twelve or fourteen lots consigned from growers in the immediate locality were of the highest excellence in point of quality. Between four of these the competition was very close, and it was only by careful consideration of the various points that the Judges were able to arrive at their decision. They awarded the prize to Mr. James Minto, Caledonian Brewery, Jedburgh, whose exhibits measured 16 inches in length by 6 inches in circumference; and notwithstanding the difficulty attending the task, their decision seemed to meet with the approval of all concerned. The gentlemen who officiated as Judges were Mr. John Cairns, The Hirscl; Mr. Adam Renton, The Lees; and Mr. William Henry, Rowchester, a noted raiser of the Henry's Prize Leek, a variety which was in much request for exhibition ten or twelve years ago."

— THE CHRYSANTHEMUMS AT WADDON HOUSE, CROYDON, the residence of Phillip Crowley, Esq., have been remarkably fine this year,

and the gardens, which are so well managed by Mr. Walter King were visited last week by a large party of members of the Royal Horticultural Society's committees and local gardeners. The Chrysanthemums form one of the best private displays we have seen this season, and there is also too much of general interest in the other houses to be dealt with in a brief note. Plants are thoroughly well grown at Waddon House, and the collection comprises some remarkable specimens.

— GARDENING APPOINTMENT.—Mr. Temple, for some years foreman at Messrs. T. Hewitt & Co.'s Nurseries, Solihull, Birmingham, has recently left their service on his appointment as head gardener to Lord St. Oswald, Nostell Priory, Wakefield.

— HOOPER & CO., LIMITED, COVENT GARDEN.—We learn that the report of the accountants of this Company, recently presented to the Board, showed a profit of 9 per cent. for the first half of the present year, and that it was decided to pay an interim dividend at the rate of 6 per cent.

— A JUBILEE TREE AT BRIDGE OF ALLAN.—In commemoration of the Jubilee of Her Majesty's reign, a seedling of the fine old Sycamore "*Queen Mary's Tree*," from Craigmillar Castle, near Edinburgh was recently planted in Cleopatra Place, Bridge of Allan, by Dr. Alex. Paterson. Agreeable to the wish of the donor, the sapling was named "*The Queen Victoria Jubilee Tree*." The ceremony was witnessed by a considerable number of spectators, the members of the Police Commission attending in their official capacity. Among those present were Chief Magistrate Drysdale, and Messrs. Graham, Maclean, Gray, Shaw, Cramb, Rose, Carmichael, and Philp; P. Buchanan (assistant clerk to the Commissioners), W. Cousine (Master of Works), Thomas Cumming, A. C. Dick-Cleland, &c. Dr. Paterson performed his agreeable duty in a workmanlike manner. The operation completed, he said:—"Provost and Commissioners, I have to thank you for having so kindly complied with my request to allow me to plant a tree in Cleopatra Place, Bridge of Allan, to commemorate the Jubilee year of our beloved Queen. This, as you know, I had intended to ask your permission to do on the Jubilee day, which was so loyally held in Bridge of Allan, but that season of the year was somewhat unsuitable for planting such a tree. The tree which I have procured for this purpose is a seedling from *Queen Mary's Tree* at Craigmillar Castle, near Edinburgh, commonly known in Scotland as the Sycamore tree. The mother of the tree I have now had the honour of planting has stood '*the battle and the breeze*' for many centuries, as all Scotchmen know, and I trust, Provost and Commissioners, in handing over this tree to your custody, and that of your successors, you will all take special care of it." Several other speakers followed, and Mr. Graham complimented Dr. Paterson highly upon the numerous services he had rendered to Bridge of Allan.

— THE HULL CHALLENGE VASE.—Mr. R. Falconer Jameson, Chairman, Hull and East Riding Chrysanthemum Society, writes—"I will not attempt to follow Mr. Udale through his arguments, but will merely remark that as he says he did not intend to impute unworthy motives to our Committee, I fully accept his statement. Mr. Udale in his postscript of his letter in last week's issue suggests that a clause should for the future be inserted in the conditions relating to challenge cups, providing that in case of the death of an employer his interest in the competition shall die with him. The condition should rather be that in case of the death of an employer the interest in the competition shall descend to his executors in case they carry on the gardens, and also elect to carry on the competition. Everyone will, after Mr. Udale's last letter, give him credit for not wishing to injure the Hull Society, but the suggestion contained in his postscript clearly indicates that he failed to grasp the salient points of the case."

— THE FLORAL COMMITTEE OF THE NATIONAL CHRYSANTHEMUM SOCIETY held a meeting in St. Stephen's Hall, Westminster, on Wednesday last, when the following members of the Committee were present:—E. Sanderson, Esq., in the chair, and Messrs. R. Ballantyne, W. Holmes, H. Cannell, J. P. Kendall, C. Gibson, Lewis Castle, G. Gordon, J. Mardlin, J. Langdon, J. Bevan, S. Gilbey, C. Swift, R. Owen, and G. Stevens. A silver medal was awarded to Mr. G. Stevens, Putney, for a stand of blooms comprising the following new varieties:—*Buffalo Bill*, Putney George, Ralph Brocklebunk, Edwin Molyneux, Lady Cave, Mr. Garnar, Mrs. Lewis Castle, Laly T. Lawrence, Mr. H. Matthews, Lord Eversley, Miss Nichols, and Mrs. Norman Davis. A bronze medal was secured by Mr. Owen also for a stand of new

varieties. A large number of varieties was shown for certificates, the following being honoured:—Charles Gibson, incurved, a bronze sport from Mrs. Norman Davis (Mizen); Maggie Mitchell, Japanese (W. and G. Drover); Miss Annie Lowe, pale yellow sport from the Anemone Lady Marguerite (Lowe); Agnes Flight, White Japanese (Flight); Album Fimbriatum (Flight); and Primula Emperor (Cannell).

### SOFT WATER FOR GARDENS.

CAN you use your powerful influence through the Journal to induce owners of property to think of the soft water supply? We, like many others, during the greater part of last summer were in great straits as to a supply of water, for many weeks we had to rely upon what was carted a long distance, and that of the hardest spring water. Now, after a very moderate rainfall all our tanks are full and running to waste, whereas if it could only be stored enough could be secured to take us well through the driest of summers and of the best possible quality. I think if the matter were taken up in the Journal it would induce many employers to consider the matter. It is surprising how soon many forget the past as soon as the rain comes, and how little notice is taken of suggestions. It will take many a day to obliterate from my mind the trials of the past summer. I believe nearly every place would catch enough water for all purposes if only tanks large enough were made to hold it. I should be pleased to see the thing well taken up by some of your more enlightened correspondents. I think great good would be the result. We are much indebted to you for many things that have already appeared in the Journal.—C. E. W.

### GROS COLMAN GRAPES NOT COLOURING.

AT this season of the year it is pleasant to see a few lines on Grapes. Your editorial reply on this subject is good, yet with your permission I would add thereto.

In the case quoted on page 428 I at first thought the fact of these Gros Colman being started early on the 15th of January would have insured a certainty in colouring, and I will not say it would not have been even with the previous year's treatment with a grower who knew the requirements of this peculiar yet valuable keeping Grape. It is not, however, heat, sun, ventilation, manure, water, or any one thing that will colour a crop of good fruit, but a combination of all. While acknowledging the quantity of sun heat in the short Jubilee summer I do not think that generally this did the good that the same amount of sun would have done over a longer period. Drought, and consequently a short supply of water, did not benefit the growing of Gros Colman. What this has done in some places is to present a crop of very indifferently coloured Grapes and Vines almost leafless in September. That the heavy crop of 1886 has left its mark is a fact, and had "A Young Head Gardener" left six bunches only this year the chances even then would have been against him. No Grape shows more the result of overcropping than this variety. We might one year have 30 or 40 lbs., the next 10 lbs., besides the Vine showing the evil other ways.

Deficiency of flavour at once tells me this variety did not receive its proper treatment. Advice can be given and taken freely on the subject of colouring, but no hard or fixed laws can be laid down.—STEPHEN CASTLE, *West Lynn*.

### MEASURING CHRYSANTHEMUMS.

IN answer to your correspondent (page 425), I may say that although the board for measuring Chrysanthemums gives only the horizontal diameter, it is the easiest possible matter to measure the depth of any flower when placed on the board. For this purpose we have an ordinary 2 feet rule (four fold), the two ends (marked 1 to 6 and 18 to 24 inches) are turned down at right angles, the whole thus forming three sides of an oblong, or perhaps I should say one side and two ends. The ends are dropped down on opposite sides of the board until the horizontal (intermediate 12 inches) length rests on the summit of the flower. The depth is then read at either end, counting of course from the angles. By a combination of the board and rule the "actual size" of any flower can be gauged, but I have yet to learn of any contrivance that will accurately gauge the "quality" of a flower. Perhaps your correspondent will oblige.—THOS. WINKWORTH.

### CATTELEYA LAWRENCIANA ROSEA SUPERBA.

CATTELEYA LAWRENCIANA has already become a favourite with orchidists, and fine varieties have appeared in several collections. Probably the best of these is that depicted in the woodcut (fig. 55) which Messrs. Veitch & Sons have described under the varietal name given above in their monograph of Cattleya and Lælia just issued. The illustration was prepared from the plant in Baron Schroder's collection at The Dell, Egham, and faithfully represents the specimen there grown in a small basket, showing at once the sturdy habit and floriferous

character of the plant. The flowers, too, are of an extremely rich rosy purple, lighter in the centre of the lip.

Referring to the history of *C. Lawrenceana*, Messrs. Veitch state that it was "first discovered by Sir R. Schomburgk during his explorations of British Guiana, 1840-44, in the sandstone region of the Roracina, who, however, mistook it for *C. Mossiae*. It was re-discovered in the spring of 1884 by Mr. Seidl while collecting Orchids for Messrs. Sander & Co. It was also met with afterwards by Mr. Everard im Thurm while botanically exploring the same region."

### CHRYSANTHEMUM SHOWS.

FALMOUTH.—NOVEMBER 9TH, 10TH, AND 11TH.

A HIGHLY satisfactory Show was held in the Polytechnic Hall on the above dates in aid of the Falmouth Building Observatory Fund. The Japanese included some handsome blooms, but the incurved were not shown at their best, being unusually late. Beside the competing exhibits Mr. Prideaux Brune of Padstow (gardener, Mr. W. Brown), sent some handsome specimens, which were generally admired. They included twenty-four Japanese, eighteen incurved, twelve reflexed, six large-flowered Anemone, and twelve Pompons of the best varieties. Great praise is due to the Executive Committee, and also to the obliging and energetic Hon. Secretary (Mr. J. P. Cregoe) for the excellent manner in which the Show was conducted.

CUT BLOOMS (open classes).—For thirty-six incurved blooms in not less than eighteen varieties, or more than two blooms of one variety, the prizes were a silver medal and bronze medal (those issued by the National Chrysanthemum Society). The only exhibitor was Mr. J. Britton, gardener to Mrs. Hodge, Menhay, to whom the first prize was awarded; his blooms were very good, including fine examples of Novelty, Emily Dale, Mrs. Naish, Mrs. G. Rundle, Hero of Stoke Newington, and Empress Eugénie. For twelve incurved Mr. J. Britton also won first honours; Mr. J. Jolliffe, gardener to Mrs. Norway, Lawn Cliffe, Flushing, was second; and Mr. W. Jenkin, gardener to Mr. A. F. Fynn, third. The reflexed varieties made a pleasing display, Miss Hockin, Flushing, having the best twelve blooms of Felicity, Chevalier Domage, Cullingford, Temp'e of Solomon, La Belle Blonde, and Webb's Queer. Mr. R. Johnson, gardener to Mrs. A. Fox, was second, and Mr. W. Jenkin, third. The principal class, No. 17, was that for twenty-four Japanese blooms, distinct varieties; here the competition was remarkably keen, the flowers being substantial and richly coloured. Eventually premier honours were given to Mr. J. Bishop, gardener to Mr. F. Hearle Cock, Tullimaar, Mr. J. Britton being a remarkably good second, and Mr. R. Johnson third. The twenty-four varieties as exhibited by Mr. Bishop (silver medal) were—Peter the Great, Source d'Or, M. de Sevin, Punch, Soleil Levant, Elaine, Comte de Germiny, Wm. Robinson, Fulgore, Coquette de Castille, M. N. Davis, Maiden's Blush, M. Ghys, Bouquet Fait, M. Astorg, Magnum Bonum, Réverie, M. Lacroix, J. Delaux, M. H. Payne, L'Introuvable, Beauté des Jardins, Lady Selborne, and Bend Or. For twelve Japanese blooms, distinct varieties, Mr. J. Jolliffe was first, his Wm. Robinson, Brise du Matin, and M. Audiguier were of great size and substance, Mr. J. Britton was second, and Mr. W. Jenkin third. The large-flowered Anemone blooms were rather small, a second prize was awarded to Mr. R. Johnson. In the Japanese Anemone class the competition was keener, but the blooms on the whole were small and inferior to those of last year. Mr. J. Jolliffe again secured a first, Mr. W. Jenkin being second, and Mr. R. Johnson third. The Pompons were not well represented, Mr. W. Jenkin obtaining a second, and Mr. R. Johnson a third.

In the amateurs' classes Miss Hockin obtained the whole of the prizes awarded; her Japanese blooms were lovely specimens, Triomphe de la Rue des Coûlets, M. Lacroix, and M. Audiguier being very notable. The incurved were rather small, but Mr. Bun and Emily Dale were well grown. Extra prizes were also given to Mr. J. Bishop and Mr. J. Britton. Mr. Bishop's Lord Alcester and Empress of India were distinguished by their neatness, size of florets, and solidity.

PLANTS.—The groups of Chrysanthemums arranged for effect were one of the exceptionally beautiful features of the Exhibition, occupying the whole centre of the Hall, and the side and end galleries. Class 1 was that for a group of Chrysanthemums, twenty varieties, arranged in a space not exceeding 80 square feet, quality and general effect to be the leading features. Four competitors arranged groups, but the first honours were given to Mr. W. Ruse, gardener to Marlborough Estate, whose plants were exceedingly good and tastefully arranged. Mr. W. Jenkin was a very fair second, while third honours were divided between Mr. M. H. Richards, gardener to Mr. W. H. Leau, Armin Villa, and Mr. W. H. Harris. For six specimens, large flowered varieties on single stems (Japanese excluded), Mr. W. Jenkin was first, Mr. M. H. Richards second, and Mr. J. Britton third. Mr. M. H. Richards obtained first for his six specimens, Japanese varieties, while Mr. W. Jenkin scored another first for his three Japanese varieties. Mr. Kent was first in Pompons, and Mr. M. H. Richards first for single specimen Pompon. A special prize (£1 ls.) offered by Mr. W. Colchester, Ipswich, for the best specimen plant in the Exhibition, in the production of which "Pure Ichthem Guano" has been used, was awarded to Mr. W. Jenkin.

The competing amateurs were fewer in number than last year, but the quality of the exhibits was far superior. Mr. A. E. Skinner, with his well trained plants, carried off all the chief prizes. His exhibits were of such exceptional excellence that had he competed in the open classes in all probability he would have wrested some of the prizes from the professional gardeners. His specimen plants showed careful attention, being neatly arranged and well grown.

### DEVIZES.—NOVEMBER 15TH.

ALTHOUGH conducted and advertised in a very unpretentious manner, this Show was really one of the best held in the southern counties, and had it been more generally known what good prizes are given for cut blooms the competition would have been still keener. Mr. Thomas King, the



experienced gardener at Devizes Castle, has sole charge of all the arrangements, and it must be added he succeeds remarkably well without the assistance of a committee. The Show is held in the Corn Exchange, but this fine building is scarcely large enough for it, being as usual rather inconveniently crowded towards the evening.

Three entered in the class for six plants of incurved varieties, Mr. W. Hale, gardener to C. N. May, Esq., Elm Lodge, Devizes, being well first for perfectly trained and grandly flowered specimens of Lord Alcester, White Globe, Mrs. Dixon, John Salter, Mrs. G. Rundle, and Empress of India. Mr. H. Clack, gardener to Major Colston, Roundway Park, fully merited the award of second prize; Mr. G. Tucker, gardener to Major W. P. Clark, Trowbridge, being a creditable third. Mr. J. Webb, gardener to W. Stancombe, Esq., was the only exhibitor of four plants, and was awarded a second prize. Mr. Hale was also first for six plants of Japanese varieties, staging some of the finest specimens seen this season, and Mr. Tucker was a most creditable second. In the next class for four sorts Mr. Clack was well first, having Madame de Sevin, Madame Bertie Rendatler, Blanche Fleure, and Hiver Fleuri in capital condition, Mr. J. Webb was second. Mr. Clack was first and Mr. Hale second for plants of Pompon varieties, and for a trio of the Rundle family Messrs. Hale and Clack were respectively first and second.

There were no less than twelve competitors in the class for twenty-four cut blooms of incurved varieties in not less than eighteen varieties, many of them coming from a considerable distance. The first prize, a gold cup value £10 10s., given by C. N. May, Esq., was awarded to Mr. W. Wildsmith, gardener to Lord Eversley, Heckfield, who had a grand lot of blooms of well known sorts. The second prize, a silver cup, value £5 5s., presented by Mr. Alderman Chandler, was awarded to Mr. G. Trinder, gardener to Sir Henry Mildmay, Bart., Winchfield, and Mr. J. Horsefield, gardener to Lord Heytesbury, Heytesbury House, took the remaining prize, both having an excellent lot of blooms. Another silver cup, value £5 5s., was awarded to Mr. G. Trinder for twelve blooms of Japanese varieties, Mr. J. Horsefield being a close second, and Mr. C. W. Cook, Rendcomb Park, Cirencester, was third. The best twelve blooms of reflexed varieties were staged by Mr. W. Allen, gardener to Sir George Russell, Bart., Swallowfield Park, Reading; Mr. Wildsmith being second. Mr. Allen was also first for twelve incurved varieties, the second prize in this instance going to Mr. Horsefield. Mr. W. Hale had the best twelve blooms with foliage, Mr. Horsefield also showing well and took the second prize. Large flowered Anemone varieties were well shown, Mr. F. J. Cole, Rockleaze, Bristol, was first, and Mr. Wildsmith second. The first prize for a vase or epergne of cut flowers was awarded to Miss Louise Merritt, Devizes, Mr. Clack being second, and Mrs. Barnwell, Southbroom, third. Several pretty baskets of hardy autumn foliage were staged. Miss Hilda May was first; Mrs. Brett second; and Miss Lizzie Butler third. A valuable challenge cup awarded to the exhibitor gaining the highest number of points in the various classes was taken by Mr. W. Hale.

WELLS.—NOVEMBER 15TH AND 16TH.

The second annual Exhibition of this Society proved to be far in advance of the first attempt, several local growers having made great strides in Chrysanthemum culture, and were quite capable of holding their own against exhibitors from a distance. The Town Hall was utilised to its fullest extent, and the introduction of the electric light was for several reasons a very happy idea. Mr. A. G. Andrews is the Honorary Secretary, and Mr. R. Isgar Treasurer, and much of the success of the Show was due to their efforts, a Committee, consisting of practical gardeners, also rendering good assistance. In the plant classes the best prizes were offered for groups consisting largely of Chrysanthemums, and for these there were seven competitors, all exhibiting in a most creditable manner. Mr. T. Wilkinson, gardener to C. C. Tudway, Esq., who had a capital lot of plants arranged in a good free style, was placed first, such Chrysanthemums as Golden Dragon, Meg Merrilies, Grandiflorum, Hero of Stoke Newington, Cherub, and White Venus carrying very fine blooms. Mr. J. B. Payne, gardener to the Lord Bishop of Bath and Wells, was an extremely close second, having such sorts as Cullingfordi, Madame C. Andiguer, Balmoreau, Triomphe de la rue des Châlets, Comte de Germiny, in fine condition, as well as a good assortment of choice flowering and fine foliaged plants. The third prize was awarded to Mr. W. A. McKenzie, gardener to G. Cresswell Crump, Esq.; a fourth prize being given to Mr. G. Thyer, gardener to H. S. Bailey, Esq.; Mr. Minty, gardener to F. Berryman, Esq., being highly commended. Mr. Chislett, gardener to Mrs. Rees Mogg, was well first for six trained plants of incurved varieties, these consisting of Venus, Lord Alcester, Mrs. Dixon, Lady Hardinge, Mrs. Rundle, and Guernsey Nugget. Mr. J. B. Payne was a good second; and Mr. G. Tatchell, gardener to A. G. Andrews, Esq., third. For six Japanese varieties Mr. W. Potter, gardener to A. Colson, Esq., was well first, his group including capitally flowered plants of Nuit d'Hiver, Margot, Madame Lacroix, and Peter the Great. Mr. G. Chislett was second, and Mr. Tatchell third. The best six plants, to include three Pompons, were staged by Mr. J. B. Payne, and Messrs. W. Potter and W. A. McKenzie were respectively second and third. Several good lots of table plants were staged, Mr. Minty being first with Cocos Weddelliana and Areca luteo-venea in excellent health, and Mr. J. B. Payne was a good second. Mr. Wilkinson was first for larger fine-foliaged plants. A capital lot of Primulas were staged. Mr. Payne took the lead with a well-grown lot, these having fresh compact foliage and good tuesses of bloom, the second prize going to Mr. T. Wilkinson, and the third to Mr. W. Lock, gardener to Mrs. Wollen. Messrs. Brown and Humphries each sent a lot of flowering and fine foliaged plants, which were arranged in various parts of the hall, and added largely to the general effect.

There was good and close competition in all the classes for cut blooms. The principal class for twenty-four distinct varieties to consist of equal numbers from the Japanese and incurved sections. Five lots were staged, and after a long scrutiny the first prize was eventually awarded to Mr. W. A. McKenzie, whose best were Madame Lacroix, Baronne de Prailly, Elaine, Triomphe de la rue des Châlets, Madame Laing, Margnerite Marrouch, Empress of India, Lord Alcester, Princess of Wales, Prince Alfred, Golden Empress, Eve, and Lady Hardinge; Mr. J. B. Payne was a very close second, and Mr. J. Aplin, gardener to W. Meath Baker, Esq., Gloucester, third. With twelve incurved sorts Mr. McKenzie was again first, Mr. J. B. Payne being second, and Mr. J. Penny, gardener to G. H.

Hicks, Esq., third, there being only a very few points dividing them. There were six competitors in the class for twelve Japanese varieties, the best four lots staged being of nearly equal merit. Mr. G. Tatchell, who was placed first, had capital blooms of Boule d'Or, Belle Paule, Elaine, Baronne de Prailly, Soleil Levant, and Dormilon. The second prize was awarded to Mr. McKenzie, equal thirds being given to Messrs. Payne and Aplin. Mr. Payne had the best stand of Pompons, these being well set up, and Messrs. Penny and Tatchell were respectively second and third. Mr. Payne's first prize bouquet of Chrysanthemums and Ferns was very pretty and more chaste than is often seen when only these flowers are used; Mr. W. Lock was second and Mr. T. Wilkinson third. The last named had a grand vase of Chrysanthemums and greenery, and was first, the second prize going to Miss A. Welch. For a basket or vase of autumn foliage and berries Mrs. Percy E. Barnes was first and Mrs. Payne second, both having very tasteful arrangements.

Fruit was well and extensively shown. Mr. Payne was first for two bunches of black Grapes and Mr. T. Wilkinson second, both having Alicante in good condition, the third prize going to Mr. W. Lock. Mr. Payne was first for two good bunches of white Muscats and Mr. Wilkinson second. Mr. J. Wilkinson had Pear Doyenné du Comice in good condition and was first, Mr. Payne being second with well-grown Easter Beurré, and Mr. R. J. Watton third. Mr. Wilkinson was first for three varieties of dessert Apples, Messrs. Payne and Minty taking the remaining prizes. The first prize for three dishes of culinary Apples went to Mr. Aplin, who had fine fruit of Lord Clyde, Hanwell Souring, and B'enheim Pippin; Mr. J. Hall was second and Mr. Payne third. The last named was first for a fine dish of Tomatoes, Messrs. Wilkinson being respectively second and third.

CLONMEL.—NOVEMBER 15TH.

The annual Show at Clonmel, Ireland, was held in the Court House. There was a larger entry than, and the exhibits all round exceeded in quality anything that had ever been witnessed there before, while the attendance of visitors, at least in the afternoon, was greater than at the previous show. The members of the Committee who undertook the arrangements had no small share of work on hand; but they were equal to the occasion, the result of their efforts being that the room in which the Show was held presented a most tasteful and attractive appearance. Large and beautiful collections of exotic and other plants were kindly sent for decorative purposes by Mrs. Bagwell, from Marlfield; Mr. G. Gongh, Birdhill; Mr. F. Clibborn, Anner House; Mr. Phelan, Spring Garden; Mr. H. S. Boyd, Suirmount; Mrs. Malcomson, Minelia; Mrs. Crean, Coolgreany, and Dr. Garner. Amongst their contributions were some very beautiful Orchids in flower, Begonias, Caladiums, Crotons, Ferns, Dracenas, and other foliage plants. These were arranged along the centre of the stage, and contrasting with the magnificent bloom of the Chrysanthemums all round, added greatly to the general effect of this horticultural exhibition. The Stewards, by whom all the preliminary details were kindly undertaken, were Messrs. Thomas Phelan, Henry S. Boyd, and F. Clibborn. Those gentlemen seemed to have spared no effort to fulfil the task entrusted to them in the most satisfactory manner.

The principal exhibitor of plants was George Gough, Esq., Birdhill (gardener, Mr. T. Bulfin), but Mrs. Malcomson of Minelia (gardener, Mr. J. Crehan), also showed some good plants. The cut blooms were numerous and of satisfactory quality, the leading prizes being secured by Frederick Clibborn, Esq., Anner House (gardener, Mr. Crawley); Raymond de la Poer, Esq. (gardener, Mr. Crawford); Thomas Phelan, Esq. (gardener, Mr. Halpin); Mrs. Malcomson, and H. S. Boyd, Esq., Suirmount (gardener, Mr. P. Darrell). Fruit was well shown by Mrs. Malcomson and Mrs. Crean.

There were also successful shows at Waterford and Tipperary, at which several of the same exhibitors competed.

WATFORD.—NOVEMBER 15TH AND 16TH.

The second Exhibition of this Society, held in the Watford Agricultural Hall, proved a most successful one. Groups of plants arranged for effect were especially plentiful and good, no less than twenty-two of various dimensions being disposed in the body of the hall, and the effect by gas-light, looking from the gallery, was grand. Mr. Myer, gardener to the Earl of Clarendon (President of the Society), had arranged, not for competition, a beautiful miscellaneous group at one end of the Hall backed up with large Palms, Dracenas, &c., and had these been given a central position the effect would have been even better. Dinner-table plants were shown in fine condition by several exhibitors, and all placed together on a long table at one end of the gallery. Had they been disposed down the centre of tables carrying the stands of cut blooms the plants would have shown off to greater advantage and improved the general effect. The schedule comprised four divisions for gardeners and amateurs, and one each for cottagers and ladies.

GROUPS.—In the open class for a group of Chrysanthemums to occupy a space not exceeding 50 square feet Mr. Wilson, gardener to G. Rooper, Esq., Watford, was first with well-arranged plants; second, Mr. Davies, gardener to E. A. Woolley, Esq., Abbots Langley; third, Mr. Dinsmore, gardener to T. F. Blackwell, Esq., Harrow Weald, with dwarf plants, but the pots too large in front. For a similar sized group open to members only, Mr. Kirby, gardener to the Honourable Mr. Justice Charles, won first honours; second, Mr. Brown, gardener to the Right Hon. Lord Esher; and third, Mr. Brown, gardener to J. E. B. Cox, Esq., Mead Mount, Mill Hill. Classes were also provided for groups of 25 and 20 square feet, and in both the competition was keen and the groups effective, but we failed to obtain the names of the successful competitors. For a miscellaneous group of plants to occupy a space of 50 square feet seven competitors entered, Mr. Brown, Mead Mount, Mill Hill, first with good foliage and flowering plants rising out of a groundwork of Adiantums; second, Mr. Dinsmore; third, Mr. Condy, gardener to S. J. Blackwell, Esq., Harrow Weald; Mr. Beckett, gardener to H. H. Gibbs, Esq., Aldenham House, Elstree, was the principal exhibitor of trained plants, having grandly flowered incurved and Japanese varieties, each about 5 feet across. The three varieties of incurved were Prince of Wales, John Salter, and Mrs. G. Rundle; the Japanese, Madame Lacroix, Mons. H. Jacotot, and Maiden's Blush. Mons. H. Jacotot was extremely fine, and, in addition to the first prize in the class, this exhibit was awarded

the silver medal offered by Messrs. Wood & Son, horticultural sundriesmen, Wood Green, for the most meritorious exhibit in the Show.

**CUT BLOOMS.**—Numerous classes were provided for these, but some of the incurved stands were very poor. The Japanese, however, made a fine display and, although the majority were not large, they were fresh and bright, and some of the winning stands from Mr. Beckett were very fine. For twenty-four incurved blooms (open to all) only two competed, Mr. Beckett being well first with very good Golden Empress, Mr. Brunlees, Lord Alcester, Princess Beatrice, Cherub, Mr. Bunn, and Jeanne d'Arc, &c.; third, Mr. Condy. In the succeeding class for twenty-four Japanese Mr. Beckett was again first with very fine blooms of Ralph Brocklebank, Baronne de Prailly, Madame J. Laing, Meg Merrilies, Boule d'Or, L'Adorable, and Album Fimbriatum; second, Mr. Blick, gardener to T. Narburgh, Esq., Elstree; no third awarded. For six incurved, one variety, first Mr. Beckett, with Jeanne d'Arc, second Mr. Blick, third Mr. Rumbold. For the same number of Japanese, first Mr. Brown, gardener to R. Henty, Esq., Abbots Langley, with Madame C. Audiguier; second Mr. Dinsmore. Two maiden classes were provided for twelve blooms of incurved and Japanese respectively; for the latter Mr. Stevens, Abbots Langley, was first, and for the incurved Mr. Dinsmore. Mr. Beckett won the special prizes offered by Messrs. Davis & Jones for three blooms of Carew Underwood and Mrs. Norman Davis, no exhibitor being forthcoming with a similar number of Edouard Audiguier for which a prize was also offered. In division 2, open to members only, Mr. Beckett was again a very successful competitor, winning easily in the principal classes. He was first for twenty-four incurved, having very good Lord Alcester, John Salter, Princess of Wales, Golden Empress, Bronze Jardin, Empress of India, Jeanne d'Arc, Princess Beatrice, Barbara, Jardin des Plantes, Prince Alfred, Mr. Bunn, and Hero of Stoke Newington. The same exhibitor won first honours with twenty-four Japanese, a very fine stand, Ralph Brocklebank, Madame C. Audiguier, Madame J. Laing, Mrs. Mahood (very good), L'Adorable, Moonlight, and Val d'Andorre being most noticeable; Mr. Rumbold was a good second. In the next class for twelve Japanese Mr. Rumbold first with very good flowers, second E. Mawley, Esq., Berkhamstead; and for the same number of incurved Mr. G. Clark, Pinner, Mr. Rumbold, and Mr. Stevens were the prize-winners. Classes in division 3 were open to members employing not more than two gardeners, and here Mr. Blick, Elstree, was first for twelve incurved with a stand of very fine solid blooms, second Mr. Clark, third Mr. Layzell, gardener to the R. v. K. F. Gibbs, Elstree; and for a similar number of Japanese Mr. Mawley first with a fine stand of flowers, including Meg Merrilies, Japonaise, Thunberg, Boule d'Or, Fair Maid of Guernsey, Maiden's Blush, and Triomphe de la Rue des Châlets; second Mr. Layzell, third Mr. Davis. For twelve bunches of Pompons, not less than six varieties, Mr. Beckett was first, Mr. Brown, Abbots Langley, second; and for the same number of Anemone Pompons Mr. Brown first, Mr. Beckett second.

**FRUIT AND VEGETABLES.**—These made a fine display, especially the latter, the produce being of fine quality. Out of the numerous classes for vegetables Mr. Beckett was first for twelve dishes with a splendid collection, and Mr. Henty second, and Mr. Beckett with produce equal to that shown in the preceding class, won first honours for six varieties, the prizes given by Messrs. Sutton & Sons, Reading. Mr. Layzell had the best eight varieties in division 3. In the fruit classes Mr. Beckett was easily first for a collection of six varieties, which included a very fine Smooth Cayenne Pine, good Muscat and Alicante Grapes. He also had the best six dishes of Apples, fine, highly coloured examples of Fear's Pippin, King of the Pippins, Cox's Orange Pippin, Wellington, Blenheim Orange, and Mère de Ménage. For three bunches of white Grapes, first Mr. Blick with good Muscats; second Mr. Brown, Mill Hill; and three bunches black, first Mr. Beckett, second Mr. Blick. Mr. Humphry, gardener to S. Johnson, Esq., Glenhaven, Elstree, also exhibited three large well-coloured bunches of Gros Colman, winning the special prize offered by Mr. F. G. King. Numerous other classes for Pears, Apples, &c., were well filled, the produce in most instances being very good.

Groups of plants, not for competition, were staged by Mr. Darby, Watford; Messrs. Cutbush & Son, Highgate; and Mr. Jones, gardener to E. H. Lloyd, Esq., Langleybury; Messrs. Lane & Son, Berkhamstead, also exhibited a large and representative collection of Apples.

#### WINCHESTER.—NOVEMBER 15TH AND 16TH.

ANOTHER successful Show was held by this young Society in the Guildhall on the date named. The cut blooms and fruit were arranged on tables running the length of the central hall, with table plants and Primulas on a raised platform down the centre of each table. Groups of Chrysanthemums and miscellaneous groups were arranged at the sides of the hall, while on the front of the stage grand specimen plants of Chrysanthemums. Cut blooms formed the chief attraction, and the chief class was that for forty-eight blooms, twenty-four incurved in not less than eighteen varieties, not more than two of one sort, the same conditions restricting the Japanese. Five competed; Mr. E. Molyneux, gardener to W. H. Myers, Esq., Swanmore Park, Bishop's Waltham, was first; his incurved were handsome blooms, the varieties being as follows:—Lord Alcester (2), Empress of India (2), Queen of England (2), Golden Empress (2), Alfred Salter (2), Emily Dale (2), Jeanne d'Arc, John Salter, Princess of Wales, Mr. Bunn, Barbara, Hero of Stoke Newington, Mrs. Heales, Lady Hardinge, Princess Teck, Empress Eugénie, and Mr. Brunlees. The Japanese were Madame C. Audiguier (2), Fair Maid of Guernsey (2), Baronne de Prailly (2), R. Brocklebank (2), Meg Merrilies (2), Madame Laing, M. J. M. Pigny, Mons. H. Elliott, Belle Paule (2), Criterion, Edwin Molyneux, Boule d'Or, Hon. M. S. G. Adams, Avalanche, and Martha Hardinge Messrs. W. & G. Drover, nurserymen, Fareham, were second, the Japanese being very heavy, finely coloured, and well staged. Many fine blooms were staged amongst the incurved, but there was a want of evenness and finish that lost them a few points. Third Mr. W. Neville, gardener to F. W. Flight, Esq., Cornstiles, Twyford, Winchester, with smaller blooms, but fresh and neat. Fourth Mr. C. Warden, gardener to Sir F. Bathurst, Clarendon Park, Salisbury. For twenty-four blooms in not less than eighteen varieties, any sort allowed, Mr. J. Bowerman, gardener to C. Hoare, Esq., Hackwood Park, Basingstoke, was a good first. Japanese in the back row were fine, the middle and front rows were incurved varieties, large and full, yet a trifle rough. Mr. G. Trinder, gardener to Sir H. Mildmay, Bart.,

Dogmersfield, Wokingfield, was second, and Mr. Pope, gardener to Earl of Carnarvon, Highclere Castle, Newbury, third. For twelve blooms incurved five entered; Mr. Molyneux led. Mr. Neville was second with smaller but equally neat blooms, and Mr. J. Bowerman was third. For twelve varieties of Japanese Messrs. W. & G. Drover were easily first for a heavy stand, second Mr. Neville, and Mr. J. Mildon, gardener to Mrs. Turner, Kingsworthy, was third. For twelve blooms, reflexed, in not less than eight varieties Messrs. Drover were first with deep full flowers, Mr. Neville second. For same number of Anemone varieties Messrs. Drover was again first with a capital stand, Empress, Middle Cabrol, Gluck, and Souvenir de L'Ardenne being the best, second Mr. Neville. For twelve blooms, not less than eight varieties, Mr. J. Dauncey, gardener to J. B. Stone, Esq., Buckfield, Basingstoke, first, Mrs. Rewsbury second. Twelve blooms open to those not having won a prize previously: here the Hon. Secretary, Mr. C. Shenton (gardener, T. Annells), The Glen, Golden Common, Winchester, was well ahead with capital produce. The best of three stands of Pompons, arranged in threes, twelve varieties, came from Mr. E. Molyneux, Mr. Neville was second, and Mr. Shenton third.

For the best collection of Chrysanthemums arranged in a space 8 feet by 6 feet, quality and general effect to be the leading features, Mr. W. Wareham, gardener to T. Coke Burnell, Esq., Egmont, Winchester, was first with plants bearing good blooms, but the arrangement was only moderately good. For six specimen Chrysanthemums, distinct varieties, Mr. Wakeford, gardener to W. G. Harris, Esq., Shirley, was easily first, staging specimens remarkable for their freedom of flowering and evenly trained. Peter the Great, Mrs. Sharpe, Madame Bertie Rendal'er were most noteworthy. For the best miscellaneous group of plants in a space 8 feet by 8 feet, Mr. J. G. Axford, gardener to C. Shipley, Esq., Twyford Moors, was first; second, Mr. Neville, both showing well.

Fruit was a good show, especially of Grapes. For three distinct varieties, one bunch of each, Mr. J. Bowerman was first amongst six competitors, Alicante, fine; Mrs. Pearson, finely coloured; Muscat of Alexandria, medium bunch, superbly coloured. Mr. Molyneux followed, Barbarossa being fine amongst his. Mr. T. Weaver, gardener to W. W. Beach, Esq., Oakley Hall, Basingstoke, being third. For two bunches of black Grapes Mr. Molyneux led the way with perfect samples of Alicante; second, Mr. Weaver. For the same number of bunches of white Grapes, Mr. Bowerman was easily first with fine ones of Muscat of Alexandria; second, Mr. J. Chalk, gardener to G. Read, Esq., Westwood, Wilton Road, Salisbury. Mr. Molyneux had the heaviest bunch, one of Barbarossa, 8 lbs. 12 ozs. For three varieties dessert Apples, Mr. G. Best, gardener to C. W. Chute, Esq., The Vyne, Basingstoke, was first with capital samples. For three dishes kitchen Apples, Mr. W. Butt, gardener to the Earl of Northbrook, Weir Cottage, Alresford, was first. For three varieties Pears, Mr. G. Trinder was first, Beurré Diel, Beurré Clairgeau being the best.

Vegetables were finely shown, the competition being brisk, Mr. R. Lye, gardener to W. H. Kingsmill, Esq., Sydmonton Court, Newbury, being awarded premier honours for eight varieties. Especially good were the Cauliflowers, Intermediate Carrots, Chancellor Potato, and Prizetaker Leeks. Mr. Bowerman was second, showing well; third, Mr. Dauncey.

The most tastefully arranged stand of Chrysanthemums with foliage, Grasses, &c., for table decoration was one by Miss Flight, who used single flowered kinds effectively; Miss Wells, College Street, Winchester, was second. Misses B. and A. Flight were the prizewinners for the best arranged stand of hardy shrub, Ferns, &c., both showing much taste in the arrangement. The arrangements were well carried out under the direction of the Hon. Secretary, Mr. C. Shenton.

Messrs. Bunyard & Co., the Old Nurseries, Maidstone, had a very fine collection of Apples and Pears, as many as 150 dishes; the larger kinds of Apples, such as Blenheim Orange, Cox's Pomona, Warner's King, Peasgood's Nonesuch were arranged in square baskets, making a most attractive display, and were much admired by a crowd of visitors.

#### CUCKFIELD.

THIS Show was held at the Talbot Assembly Rooms, Cuckfield, on the 15th and 16th inst., and considering the modest prizes offered the Show was a good one, and a success in every respect. This little town can now boast of a regularly arranged Chrysanthemum Society, starting with the respectable number of sixty members. The chief attractions were the groups and the cut blooms staged, which were very good, and quite a credit to growers. The modest sum of 36s. divided into five prizes brought eight competitors for groups. They were arranged against the walls of the room in semicircles of 5 feet radius. First prize was rightly awarded to Mr. H. Scutt, gardener to T. W. Erle, Esq., Millhall, for an excellent group of well grown plants. The second place was given to Mr. R. Togli, gardener to T. T. C. Lister, Esq., Borde Hill. The third to Mr. F. Dowding, gardener to Mrs. Lister, The Grange, Warninglid, for splendid blooms on tall plants totally unsuited for grouping. The fourth and fifth prizes were awarded to Mr. W. Holden, gardener to Capt. Farmer, Whitmore; and Mr. J. Hillman, gardener to Mrs. Latbam, Knowle, respectively with dwarf plants not showing particular high cultivation. Some dissatisfaction was expressed at the decision of the Judges, as undoubtedly one of the groups showing best cultivation, foliage hanging over the pots and good blooms at the top, was left out. No doubt more care will be taken by all another year in providing dwarfier plants, to give the groups a more finished appearance. For two specimen plants, incurved, Mr. F. Feist, gardener to F. M. Hutch, Esq., Henstead, was first, Mr. H. Scutt being first for two Japanese with floe plant. The latter was also first for two standards. With six Primulas there were seven entries. Mr. J. Mitchell, gardener to M. S. Maberley, Mytens, carried off the first prize, closely followed by Mr. W. Manton, gardener to Mrs. C. Borren, Pickwell Lodge, Bolney; and Mr. J. Lingley, gardener to T. W. Best, Esq., Harvest Hill. There were five exhibits of six Solanums. Mr. G. Stringer, gardener to R. A. Bevan, Esq., Horsgate, was first with fine plants well ripened. Mr. J. Umpleby, gardener to H. Woodcock, Esq., Be'more, was second with finely berried plants, but not quite so well coloured.

For twelve incurved Mr. F. Roberts, gardener to R. C. Nichols, Esq., Highby Manor, Balcombe, was first with fine blooms, Mr. W. Manton taking the same position for twelve Japanese, the latter being also first for twelve Pompons. The greatest interest was manifested in the special prize, open



to a l within a radius of six miles, for twenty-four blooms, twelve incurv d and twelve Japane e. There were five competitors, and the contest was a good one. Mr. F. Venn, gard-ner to W. Starry, E q., Paix Hill Park, Lindfield, was the winner with fine well-staged blooms. Mr. F. Godbr, gardener to Dr. Wither Moore, The Oaks, Burgess Hill, was a good second, and Mr. Roberts third. Had the latter gentleman staged his blooms with as much care as Mr. Venn he might have occupied a different position, for he had both size and substance.

FRUIT.—For two bunches of black Grapes Mr. Feist was first with good Gros Colman, Mr. Inglis being second with Alicane. Mr. Geo. Warren, gardener to Mrs. Hankey, Balcombe Place, Balcombe, was the only exhibitor of white Grapes. Mr. Harding, gardener to B. B. Hodgson, E q., was first for two dishes of dessert Pears with very fine fruits of Nouveau Poiteau, and

ment in the quality of the exhibits without exception. Groups of miscellaneous plants were of high merit, and those of Chrysanthemms and foliage plants were superior to those of past years. Specimen plants were not quite so numerous, but there was a general improvement in quality.

The classes devoted to cut flowers were well filled, and the flowers were of very high quality, especially those exhibited by Mr. Gill, gardener to W. Oldham, Esq., of Gainsborough. These deservedly took the first prize in the open classes, and included the best bloom in the Show, a fine example of Madame C. Audiguier. Mr. Oldman was also awarded the National Chrysanthemum Society's certificate for the excellence of his exhibits. Other fine blooms were shown by W. Ashley, Esq., who took five first prizes and one second; C. E. Marfleet, Esq., who obtained four first prizes, including the prize for the best incurv d cut bloom in the Show a superb



FIG. 55.—CATTLEYA LAWRENCIANA ROSEA SUPERBA. (See page 448).

Duchesse d'Angoulême, but it is questionable if the palate had been appealed to if they would have been superior, and Mr. Stringer's Burre Diel and General Foltleben, which were placed second. For four dishes of Apples there was a good competition, Mr. F. Dowding took premier place, his Blenheim Pippin and Mère de Ménage being fine.

There was a keen contest with trays of vegetables. Mr. Manton maintaining his leadership in this department, but was closely followed by Mr. Stringer and Mr. Mitchell. There were eight entrées. The amateurs and cottagers, who make one of the best cottagers' summer shows in the county, do not seem to have quite entered into the spirit of this autumn campaign. Mr. Geo. Warren sent, not for competition, over thirty dishes of fruit; and Mr. Haskell, gardener E. Noel, Esq., Lyndhurst, Warninglid, sent a similar exhibit of Primulas, a good strain of various colours, a blue one being noticeable.

LINCOLN.—NOVEMBER 15TH AND 16TH.

The fifth annual Exhibition was held in the New Corn Exchange as in past years, and the Committee are to be congratulated upon the improve-

specimen of the Hero of Stoke Newington; T. C. Bourne, Esq., who took one first and five second prizes, one of the finest specimens of Mr. Bunn ever seen at the Show being included in his collection; and by Septimus Lowe, Esq., Thomas Bell, Esq., and Mr. G. R. Brailsford. In the amateur classes Mr. E. Bevors carried nearly everything before him. Mr. Herring, gardener to A. Shuttleworth, Esq., Hartsholme Hall, exhibited a very meritorious collection of cut flowers not for competition, and these were deservedly awarded the National Society's certificate. N. Clayton, Esq., W. J. Warren, Esq., and Messrs. Pennell & Sons exhibited beautiful groups of plants not for competition, and these were highly commended. Fruits were well shown and in good condition.

The competition in the plant classes as above indicated was not very strong, and for the group of Chrysanthemms and other plants arranged for effect in a semicircle, it rested between Sept. Lowe, Esq., and H. Greenham, Esq. (gardener, Mr. Foster), the former's, which contained some very fine Chrysanthemum blooms, taking first honours. An objection was lodged against it on the ground that it was not arranged within the prescribed space, but as the objection was handed in after time it was not



entertained. Of groups of Chrysanthemums and green foliage plan arranged for effect in a semicircle, T. C. Bourne, Esq., and T. Bell, Esq., were the only exhibitors, and they ran each other very closely, the first prize eventually going to the former.

Fruit was well represented, Mr. Warrener being the most successful exhibitor of Apples and Pears; prizes being also awarded for the produce of R. H. Neville, Esq., (gardener, Mr. Hare), and H. Greenham, Esq.

The competition for vases for table decoration was very keen, Miss Pennell winning first honours with an excellent arrangement, airy and graceful in composition, but inclined to be "artificial." C. E. Marfleet, Esq., was a close second with an arrangement of chaste colouring, but with a defective base; a little more Fern there would have altered the respective positions of the prizewinners.

The flowers exhibited in the cottagers' class was of very high merit, and the improvement made during the past year clearly demonstrates what may be accomplished by perseverance.

#### BIRMINGHAM.—NOVEMBER 16TH AND 17TH.

THE Birmingham Chrysanthemum Society held the twenty-seventh annual Exhibition in the Town Hall, a place well adapted for the purpose, excepting that it is now becoming too small, so numerous are the exhibits. A decided improvement was manifested on this occasion in the arrangement of the various products. In a broad two-faced bank down the centre of hall was arranged on one side the groups of Chrysanthemums, of which there were five, making a grand display as viewed from the gallery. Upon the opposite side were the specimen plants on a raised stage, standing three and four deep. Down the centre was a row of tall Palms, which lent a graceful character to the whole flowering plants below. On the sides of the hall, on long tables, were placed, on the side next to the body of the hall, the Grapes, Apples, and Pears, of which 150 dishes were staged, owing to the increased prizes offered, while the quality left nothing to be desired. On the opposite sides of the tables were arranged the Primulas, for which Birmingham has long been noted. Mr. Dyer was the chief exhibitor of plants, all showing excellent cultivation, being freely flowered and possessing ample foliage. Cut blooms were a very fine display in the gallery—in fact, the whole Show was a credit to those concerned in its management, and Mr. J. Hughes, the indefatigable Secretary, deserves a special word of praise. Mr. Lathom, as Chairman of Committee, and Mr. Jones, as Treasurer, also assisted materially.

**CUT BLOOMS.**—These were shown in large numbers, as many as 1500 being staged in all classes. The principal class was that for forty-eight blooms, distinct—twenty-four incurved and the same number of Japanese—the handsome prizes of £10, £7, £4, and £2 being offered. For these eleven competitors entered. The first prize was awarded to Mr. R. Parker, gardener to J. Corbett, Esq., Impney Hall, Droitwich. The incurved blooms were large, solid, fresh, and well finished; the Japanese were heavy, the colours good and well staged. The following are the names:—Incurved: Back row—John Salter, Alfred Salter, Jeanne d'Arc (very fine), Queen of England, Lord Alcester, Bronze Queen of England (extra good), Empress of India, Lord Wolsley. Middle row—Princess Teck, Mrs. Heale, Nil Desparandum (deep), Jardin des Plantes, Prince Alfred, Golden Empress, Refulgence (rich), Beverley. Front row—Barbara, Sir S. Carey, Hero of Stoke Newington, Mr. Brunlees, Mabel Ward, Princess Beatrice, Cherub, and Mrs. N. Davis. Japanese: Back row—Boule d'Or, Madame C. Audiguier, Fair Maid of Guernsey, Triomphe de la Rue des Châlets (grand), Belle Paule (fine), Thunberg, Meg Merrilies, Baronne de Prailly. Middle row—Carew Underwood, Comte de Germiny, Jeanne Delaux, M. Astorg, Duchess of Albany (very fine), Mons. J. Laing, Japonaise, Maiden's Blush. Front row—Soleil Levant, M. Burnet, Peter the Great, M. Marrouch, Grandiflorum, Madame Laing, L'Adorable, Yellow Dragon. Mr. D. Lindsay, gardener to Sir T. Edwards Moss, Otterspool, Liverpool, was placed second. The Japanese was rather lighter, while the incurved were more uneven, particularly in the front row. Still, on the whole it was a very fine stand, and at many shows would have taken first honours. Mr. T. Lambert, gardener to Lord Harlech, Oswestry, was third, staging much smaller blooms. Mr. A. R. Cox, gardener to H. Watts, Esq., Elm Hall, Wavertree, Liverpool, was fourth. For twenty-four blooms, distinct—twelve incurved and twelve Japanese—as many as thirteen entered the lists. Mr. Parker was again first, staging very fine flowers, mainly of the variety named in the leading class. Mr. Lindsay was here again second, staging good blooms; Mr. Cox being third. For eighteen incurved, distinct varieties, amongst seven competitors, Mr. Lindsay turned the tables on his rival, Mr. Parker, by winning first honours with large well-finished blooms. Mr. Parker was an exceedingly close second, a bad bloom of Jardin des Plantes spoiling his chances of success. Mr. A. Haggart, gardener to Mrs. Forster, Moor Park, Ludlow, was third. As many as seventeen competed in the class for twelve Japanese, distinct. Here again Mr. Parker followed up his previous successes by taking first honours. Belle Paule, Triomphe de la Rue des Châlets, Duchess of Albany, Jeanne Delaux, and Boule d'Or were very fine. Mr. Lindsay was a capital second, and Mr. Haggart was a very close third, while other exhibitors followed closely. Mr. Parker was successful with twelve blooms of Anemones in not less than six varieties. These were not equal to the best staged last year. Mr. W. Comfort, gardener to G. A. Everitt, Esq., Knowle, Birmingham, followed. Prizes were offered for growers living within four miles of Stephenson Place. In all cases the blooms staged were meritorious.

**PLANTS.**—Specimen plants of Chrysanthemums were staged in increased numbers and of superior quality as compared with last year, the plants being not so severely trained, while they were freely flowered, and on the whole were most creditable. For nine large flowering varieties, Japanese excluded, Mr. W. H. Dyer, gardener to Mrs. Matigoli, Edgbaston, was easily first; John Salter was an excellent specimen, Cullingfordi was also noteworthy. Mr. G. Brasier, gardener to Sir T. Martineau, was second. For six plants, the conditions the same as in the above class, Mr. Dyer was again first. The best specimen large flowering, Japanese excluded, was a grand one of John Salter, carrying over seventy well formed blooms; these accompanied with fine foliage and free training presented a noble specimen most creditable to Mr. Dyer, by whom it was staged. J. Elkington, Esq., took second honours. Mr. Dyer had the best single specimen of Japanese, one of Val d'Andorre, 4 feet in diameter, freely flowered and of brilliant colour. Mr. G.

Brasier was second with a specimen of Madame C. Audiguier carrying fine bloom. Standard and Pompon pyramid Chrysanthemums were not remarkable for large numbers or high quality, but dwarf trained specimens in three varieties of Pompons were well shown by Mr. Dyer; Rose Trevenna, Lilac, and Golden Cedo Nulli were capital. Mr. G. Fawdry, gardener to J. Breaden, Esq., Moseley, was second, while Mr. G. Brasier was placed third. For one specimen plant to be fed with Messrs. W. Wood & Sons' liquid manure powder Mr. Dyer easily gained first honours. There was great improvement in the groups of Chrysanthemums arranged for quality and general effect in a space not exceeding 80 square feet; five competed, all staging most meritorious collections, which formed a magnificent bank down the centre of the hall. Mr. J. H. Horton, gardener to R. Chamberlain, Esq., Edgbaston, who staged a very fine group of well-grown plants. Mr. Dyer being second for dwarfier plants, the blooms not quite so good, Mr. J. Westall, gardener to J. B. Lees, Esq., Handsworth, being a good third. Primulas were staged in large numbers; Mr. T. B. Thomson, Sparkhill Nurseries, Birmingham, was an easy first for twelve Chinese, single varieties, any colour; for six, same conditions; for six double flowered, any colour; and for six Fern-leaved, any colour, with plants in all cases such as are rarely seen. The varieties were Sansation (very bright), Marquis, Princess Louise, The Queen, among the single varieties, and Lady Martineau, a new double variety, was most conspicuous in that class. Mr. E. Cooper, gardener to the Right Hon. J. Chamberlain, Highbury, Birmingham; Mr. C. Shepherd, gardener to W. M. Ward, Esq., Edgbaston; and G. H. Fewkes, Esq., Salby Oak, were seconds in the above classes. Mignonette, Cyclamens, Zonal Pelargoniums, and other miscellaneous plants were staged creditably, while bouquets were, as they always are, a feature at this Show, the best of the latter (nurserymen only) coming from Messrs. Perkins and Son, Coventry—a real gem.

**FRUIT.**—The Grapes showed a great improvement on other years, owing no doubt to the increased prizes offered. For six bunches, not less than three varieties, £5, £3, and £2 were offered, bringing nine competitors. First, Mr. W. Taylor, gardener to J. Chaffin, Esq., Bath, for specimens of Alicante, Muscat of Alexandria, and Lady Downe's, very fine in every respect. Second, Mr. J. Harvey, gardener to J. Watson Esq., Titchhurst, Sussex, Gros Colman being especially good. For the best three bunches of black Grapes, Mr. A. Johnstone, gardener to R. Ramsden, Esq., Knowle, was first with Gros Colman, extra fine in bunch, berry, and colour. Second, Mr. J. Harvey, who had very fine Alicante. Third, Mr. Sage, gardener to Earl Brownlow, Belton, Grantham. Eleven competed. For the same number of bunches Muscat Grapes, Mr. D. Lindsay was first, showing Muscat of Alexandria variety extra fine, the bunches being large, heavily shouldered, while the berries were large and of a splendid colour. Mr. Taylor was second with the same variety, not quite so large in bunch, but in other respects was first rate. For two bunches of white Grapes, Muscats excluded, Mr. Sage was first, staging Trebbiano in capital style. Mr. E. Gilman, gardener to the Earl of Shrewsbury, was second with the same variety. For one bunch of black Grapes, Mr. Taylor was first with Alicante, excellent in every way. Mr. A. Johnstone, gardener to R. Ramsden, Esq., Knowle, was second with Gros Colman, very fine. For one bunch of white Grapes, any variety, Mr. Taylor was first with a long tapering bunch of Muscat of Alexandria, fine both in berry and colour. Second, Mr. J. Dawes, gardener to M. Biddulph, Esq., M.P., Ledbury Park, Hereford. Third, Mr. E. Gilman. For one Pine, any variety, Mr. G. Robinson, gardener to J. Cartland, Esq., King's Heath, and Mr. E. Gilman were first and second respectively. For six culinary Apples there was keen competition. Mr. W. Green, gardener to E. V. V. Wheeler, Esq., Tenbury, was first with specimens of splendid quality. Second, Mr. Sage. Third, Mr. G. Hodges, gardener to R. Cadbury, Esq., Moseley. For the same number of dessert Apples Mr. W. Green was again first, staging finely coloured examples. Second, Mr. W. Iggulden, gardener to the Earl of Cork, Marston House, Frome, Somerset. Third, Mr. W. Brown, gardener to W. C. Alston, Esq., Elmdon Hall. For eight dishes of Pears, distinct varieties, Mr. Parker was easily first, staging fine fruits of Baurré Diel, Hacon's Incomparable, Baurré Bachelier, and Josephine de Malines. Second, Mr. Iggulden with richly coloured fruit. Mr. Parker was again first with four varieties, all good samples. Mr. P. Blair, gardener to the Duke of Sutherland, Trentham, was second; Mr. Iggulden, third.

Miscellaneous exhibits formed a strong feature. Mr. B. T. Thomson staged, "not for competition," a handsome group composed of Palms, Crotons, Bouvardias, Poinsettias, Selaginellas, and Roman Hyacinths, all set in a groundwork of Ferns. Conspicuous in this group was some highly coloured plumes of Celosias grown as pyramids, forming a rare bit of colour amongst the green surroundings. Mr. Hans Niemand, Royal Nurseries, Harbome Road, Birmingham, staged, "not for competition," a group consisting of Palms, Cyclamens, Erica hyemalis, Crotons, finely coloured, all neatly arranged. Messrs. Cranston & Co., The Nurseries, Hereford, staged a very fine lot of Apples; while Messrs. E. Webb & Son staged a capital collection of Potatoes. Messrs. R. Smith & Co., The Nurseries, Worcester, had on view a splendid collection of Apples and Pears. Messrs. W. Thomson & Sons, Clovenfords, Scotland, had fine basketful of Grapes, Gros Colman, magnificent in both bunch and berry. Messrs. Pope & Sons, nurserymen, Birmingham, were awarded a certificate of merit for grand Pelargoniums, so freely were they flowered and of such excellent colour, as was also Mr. R. Owen, Castle Hill Nurseries, Maidenhead, for a miscellaneous collection of Chrysanthemums cut blooms, one variety amongst these, Sarah Owen, being awarded a special certificate; it is a sport from Madame Laing, in the style of Criterion, but having more gold in it. Mr. Owen also received a first-class certificate for Amy Furze, a reflexed variety sent out last year. Messrs. W. & G. Drover, Fareham, Hants, received a first-class certificate for their new Japanese variety (W. G. Drover), lately described in these pages. Messrs. W. Wood & Son, Wood Green, London, had on view samples of their Orchid peat and other garden specialities; while Mr. W. Colchester had on hand a large display of their Ichthemic guano.

Messrs. Sutton & Sons, seedsmen, Reading, offered prizes for a collection of vegetables, six distinct varieties. For this there was spirited competition. Mr. J. Lambert, gardener to Col. Wingfield, Shrewsbury, was first with a very fine lot, staging Parsnips, Leeks, Celery, Cauliflowers, and Carrots; second, G. H. Kendrick, Esq. (gardener, G. Neville), Edgbaston; third, Mr. E. Burdon, gardener to F. Wilmot, Esq.

## RYDE, ISLE OF WIGHT.

THIS Show was opened by the Mayor on the 16th inst. The various exhibits filled both halls. In the class for fifty-four blooms, eighteen varieties, three blooms of each, on Cannell's system, there were seven competitors, and the Judges, Mr. Barkham and Mr. Banting had a difficult task in awarding the prizes. They, however, eventually decided them in favour of Messrs. E. Ratcliffe, S. E. Ridley, and E. R. Taplin in the order named. The ladies' class was well represented, the baskets of Chrysanthemums and the epergnes with autumn foliage and Fern attracted great attention. The silver cup (presented by J. O. Brook, Esq.), value £5, for Isle of Wight cultivators only, was, after a sharp contest between Messrs. H. Drover & Son and Mr. Wilkins, gardener to S. W. Ridley, Esq., awarded to the latter by two points. Best group of Chrysanthemums, 7 feet by 5, first and cup Mr. J. Taplin, florist, Ryde; second, Messrs. James & Son, florists, Ryde. Six specimen plants, first Mrs. Barnes, second S. E. Ridley. Single specimen Japanese, first Mrs. Harvey, Shanklin, second S. W. Ridley. Single specimen incurved, first S. W. Ridley, second S. E. Ridley. Messrs. W. & G. Drover, Fareham, secured the chief prizes in the classes for thirty-six cut blooms in twenty-four varieties; twenty-four in eighteen varieties; twelve Japanese blooms, twelve Anemone blooms, and twelve white Japanese blooms—a very good record, the other prizetakers being respectively Messrs. E. Ratcliffe, D. Hamilton, S. W. Ridley, and H. Drover. In the Isle of Wight amateurs' class J. O. Brooke, Esq., was a successful exhibitor. The silver medal for the best bloom in the Show was won by Mr. J. Wilkins with a grand example of Thunberg, Messrs. H. Drover & Son closely following with Val d'Andorre. Fruit was good, and the excellent Secretary, Mr. J. Eley, is to be congratulated on the success of the Show.

## RUGBY.—NOVEMBER 16TH AND 17TH.

THE first annual Show of the Rugby and District Chrysanthemum Society was held on the above dates in the Town Hall, when there was good competition in most of the classes. The groups from Mr. J. Parker, Victoria Nurseries, and Mrs. Caldecott, The Lodge, Rugby (gardener, Mr. B. Robinson), were an especial feature, and were accorded equal first prizes, Dr. Percival, head master at Rugby School (gardener, Mr. H. King) following. There were also good groups from the Rev. F. D. Morice, Mr. W. G. Michell, and Mr. J. W. J. Vecqueray in another class. Mrs. Caldecott had the best twenty-four cut blooms, and there were several exhibitors of miscellaneous plants. The Hon. Secretary is Mr. W. Bryant, who with a good Committee worked well to render the Show successful, and it is hoped to extend its interest another year.

## YORK.—NOVEMBER 16TH, 17TH, AND 18TH.

THIS was held in the York Fine Art Exhibition building, and was one of the best of the year. Specimen plants were very numerous and of great excellence, probably unsurpassed at any show either in number or quality. The three trained specimens exhibited by Mrs. Gulch of Holgate worthily won the silver Jubilee medal offered by Messrs. Wood & Son of Wood Green, London. These were splendid examples of cultivation, and were highly creditable to the grower. The specimen plants collectively were a considerable improvement upon those of previous years, and they, in conjunction with the groups of Chrysanthemums and foliage plants, created a floral effect not easily forgotten by those who had the privilege of seeing them. Cut flowers were well represented, and those exhibited in the large class by W. B. Richardson, Esq., Elm Bank, York, and by Mr. T. B. Morton of Darlington, could scarcely be surpassed in quality. The competition between these two was very close, the former winning by eight points only. Mr. Richardson took first honours in almost every class—eight first prizes—and we shall probably hear of him distinguishing himself farther from home another year. Fruit was excellent in general, Mr. Goodacre, Elvaston Gardens, Derby, being well to the front. His six bunches of Grapes in three varieties were beautiful samples, and consisted of good Mrs. Pearson, good bunches and berries of Gros Colman, but slightly deficient in colour, and splendid examples of Muscat of Alexandria, almost perfection in symmetry of bunch, regular and good-sized berries, and well coloured. The best two bunches of white Grapes came from Lord Hotham, and were represented by Muscat of Alexandria, superb in finish. Exhibits of Apples and Pears were numerous and of good quality. Vegetables were so good throughout the Show that it would be invidious to particularise, and any attempt in words to do justice to their high quality would necessarily come far short of their merits.

The prize list is as follows:—Group of Chrysanthemums and foliage plants.—First, Mr. J. T. Hingston; second, Dr. Baker; third, Mr. J. Key. Group of Chrysanthemums, arranged for effect.—First, Mrs. Gulch; second, Dr. Baker; third, Mr. J. Pillmoor. Six specimen Chrysanthemums, incurved.—First, Mrs. Gulch; second, Mr. T. Smith; third, Miss Steward. Six specimens, Japanese.—First, Mr. T. Smith; second, Dr. Baker. Six specimens, reflexed.—First, Miss Steward, Bishopthorpe; second, Mr. T. Smith. Three specimens, incurved.—First, Mr. T. Gulch; second, Dr. Baker. Three specimens, Japanese.—First, Mrs. Gulch; second, J. T. Hingston, Esq. Three specimens, reflexed.—First, Dr. Baker; second, Mrs. Gulch. Six specimens, Pompon.—First, Mr. T. Smith; second, Miss Steward; third, Dr. Baker. Six Primulas.—First, Mr. Makins; second, Mr. P. Wood.

*Cut Flowers.*—Thirty-six Chrysanthemums.—First, W. B. Richardson, Esq. (gardener, Mr. Folkard); second, Mr. T. B. Morton, Darlington; third, J. Holden, Esq., M.P., Keighley. Twenty-four Chrysanthemums.—First, Mr. Richardson; second, Lord Wenlock. Twelve incurved.—First, Mr. Richardson; second, Miss Moore. Twelve Japanese.—First, Mr. Richardson; second, Mr. A. Pease.

*Fruit.*—Six bunches Grapes, three varieties, two bunches of each.—First, Earl of Harrington (gardener, Mr. Goodacre); second, Mr. R. H. C. Neville (gardener, Mr. Hare); third, Lord Hotham. Two bunches black Grapes.—First, Mr. J. T. Hingston; second, Mr. T. F. Wood. Two bunches white Grapes.—First, Lord Hotham, with beautifully finished Muscat of Alexandria; second, Mr. C. H. Wilson. Assortment of Apples grown north of the Trent.—First, Mr. J. Fielden, Grimston Park (gardener, Mr. Clayton); second, Earl of Harrington. Assortment of Pears grown north of the Trent.—First, Earl of Harrington; second, Lord Hotham (gardener, J. Allsop).

*Vegetables.*—Tray of nine varieties.—First, Mr. R. Kirk; second, Mr. J. Whitehead. Tray of six varieties.—First, Mr. J. Craig; second, Mr. J. Whitehead. In other classes, Messrs. Craig, Whitehead, Kirk, Hammond, Hingston, and Theakstone divided honours between them.

The Committee are to be congratulated upon the success of their efforts to improve the cultivation of Chrysanthemums, fruit, and vegetables in the neighbourhood of York, and more liberal prizes in the classes for cut flowers would draw such competitors as would make the York Chrysanthemum Exhibition second to none in the kingdom.

## CHISWICK.—NOVEMBER 7TH.

THE Vestry Hall, near the large Green at Chiswick, presented a very gay appearance on November 17th, the occasion being the local Society's annual Exhibition of Chrysanthemums, fruit, and vegetables. In general attractiveness the Show marked a distinct advance on the one of last year, and both groups and cut blooms were of equal if not superior quality. The Society is undoubtedly moving in the right direction.

The building in which the exhibits were arranged was spacious and well lighted, ample room being found for inspecting the exhibits with comfort. The cut flower classes occupied tables in the centre, groups and specimen plants being arranged on each side. The platform at the upper end was utilised for fruit, vegetables, cut flowers, and various plants in pots. The whole arrangement reflected much credit on the Honorary Secretary, Mr. Joseph Fromow, and his assistants. The following were the most important awards:—

The class for a group of Chrysanthemums, any class, to be arranged in a space not exceeding 60 square feet, was well filled, there being five groups in competition for the prizes offered, all of considerable merit. The first-prize arrangement, that of Messrs. W. Fromow & Sons, Sutton Court Nurseries, Chiswick, was in every respect an admirable one, the group being large, the plants healthy and judiciously arranged, and the blooms of high average merit. Mr. E. Chadwick, gardener to E. M. Nelson, Esq., Hanger Hill House, Ealing, also had a most attractive arrangement. A group of a somewhat similar character, and very close in point of merit, from Mr. Wright, The Gardens, Devonhurst, Chiswick, won the remaining prize. Messrs. Harding, gardener to W. E. Tautz, Esq., Sutton Lodge, Chiswick, and G. Webb, gardener to J. R. Starling, Esq., The Chestnuts, Gunnersbury, deserve a word of commendation for the excellence of their collections. A very fine group from Mr. T. May, gardener to the Marquis of Bute, Chiswick, though not in competition, is also worthy of note, and it was highly commended by the Judges. Mr. Chadwick received the premier award for three Pempsons, trained specimens. In a similar class for large-flowered Mr. Picking, West Lodge, Mortlake was first.

In the principal class for twenty-four blooms, twelve each of Japanese and incurved, prizes to the value of five guineas were offered by Mrs. S. A. Lee. The first prize stand was an admirable one from Mr. C. J. Waite, gardener to Colonel the Hon. W. P. Talbot, Glenhurst, Esher. Mr. C. Long, gardener to E. B. Ridges, Esq., Orchard Dene, Ealing, followed with good incurved but weak Japanese flowers, the remaining prizes going to Messrs. Hudson, gardener to H. J. Atkinson, Esq., M.P., Acton, and Palmer, gardener to W. F. Hume-Dick, Esq., Thames Ditton. Mr. Waite was again to the front with twelve Japanese, a fresh, even lot of blooms. He was followed by Mr. Davis, gardener to E. Tautz, Esq., Castle Bar, Ealing, and Mr. Hudson, the former running Mr. Waite somewhat closely. Mr. W. E. Tautz presented three prizes. E. Sanderson, Esq., St. Mary's Road, Harlesden, won with twelve incurved, the blooms being small but beautifully clear, fresh, and well finished. Mr. Hudson was second and Mr. Chadwick third. Mr. Palmer won with six Japanese of one variety, showing Madame Audiguer in good condition. Mr. C. J. Waite exhibited six fine blooms of Empress of India in the corresponding class for incurved, and won easily. Other prizes went to Messrs. Hudson, Picking, Baird, gardener to C. A. Daw, Esq., Homsfield, Ealing, and Collyer, gardener to Mrs. Murrell, The Elms, Ealing. These prizes were presented by Mr. J. R. Starling. In other classes for cut blooms, prizes were won by Messrs. Palmer, Chadwick, Long, Collyer, Sanderson, and Baird, also by Messrs. Larcomb, Woodhouse, Jeffreys, Thompson, Weal, and Leary, the last named all amateurs.

Mr. Hudson was successful with four dishes of Apples, Mr. Waite being second, and Mr. Wright third. Mr. Wright was most successful with Pears, Messrs. Waite and Coombs, The Gardens, Sheen House, Mortlake, following. Mr. Hudson won with three bunches of Grapes, showing well ripened bunches of Alicante, Gros Maroc, and Muscat of Alexandria. Mr. Baird followed, Mr. Waite bringing up the rear. The latter was to the front with vegetables, showing in his usual excellent form and winning easily from Messrs. Coombs and Laing. Mr. F. G. Tautz's prizes for the best specimen stove and greenhouse plant fell to Messrs. Cowley (gardener to the prize donor), Chadwick, and Wright. The latter won the first prize offered by Messrs. Fromow & Sons for Primulas. Mr. Hucklesby (gardener to B. Hardy, Esq., Gordon House, Chiswick), and Mr. R. Wood securing the second and third awards. Mr. Hardy's prizes for table plants went to Messrs. Waite, Wright, and Davis, gardener to H. G. Lake, Esq., Fairlawn House, Chiswick, in the order named. Mr. Goodson, Askew Nursery, Shepherd's Bush, had a group of Primulas in pots that was highly commended, also a fine specimen of Chrysanthemum Cullingfordi.

## COLCHESTER.—NOVEMBER 17TH.

THE autumn Exhibition of the Colchester and East Essex Horticultural Society was held in the New Corn Exchange of that town on Thursday, the 17th inst. A good display of plants, cut blooms, fruits, and vegetables was provided, which were effectively arranged in the commodious hall by the Secretary, Mr. Quilter, who ably conducts the affairs of the Society.

The principal interest centered in the class for twenty-four cut blooms, twelve incurved and twelve Japanese, the first prize being a piece of plate, value 10 guineas, presented by the Mayor and Corporation of Colchester, and £2 in money added by the Society. The only condition under which this was offered was that it must be won twice by the same exhibitor before becoming his property, and as it was open to all England a good competition was expected. Last year, the first season it was offered, Mr. H. Lister, gardener to Lord Brooke, Easton Lodge, Danmow, Essex, won it comparatively easily, but on the occasion under notice there were five entries, and



four of the collections were so close in merit that the Judges (Messrs. J. Ridout and Lewis Castle) found it necessary to point them very carefully to ascertain who was entitled to the first position. It was then found that Mr. Lister's collection was several points ahead of the others, his blooms being more solid and deep, and he thus became the possessor of the piece of plate, but there were only four points between the second and third. The first prize stands comprised the following blooms:—Japanese, back row—Thunberg, Triomphe de la rue des Chalets, Fair Maid of Guernsey, and Boule d'Or; middle row—Madame C. Audiguier, Criterion, Val d'Andorre, and Madlle. Lacroix; front row, Marika Harding, Madame J. Laing, L'Adorable, and Belle Paule. Incurved—back row, Lord Alcester, Empress Eugenie, Queen of England, and Golden Empress; middle row, Princess of Wales, Lord Wolseley, Novelty, and John Salter; front row, Mabel Ward, Jeanne d'Arc, Refulgence, and Chernb. The blooms were fresh and good, the Japanese being especially fine. Mr. S. Pragnall, gardener to H. C. Well's, Esq., Chelmsford, who was also strong in Japanese, was second; and E. W. Flight, Esq., Twyford (gardener, Mr. Neville), was third. The Rev. H. A. Berners, Harkstead Rectory, Ipswich, won first honours with twelve incurved blooms, very neat, compact blooms. In several other classes there were also good exhibits from local gentlemen.

The best of the plant exhibits were in the classes for groups, and Mr. F. Kettle, gardener to Mrs. Egerton Green, King's Ford, Colchester, was placed first with a very tasteful arrangement of miscellaneous plants; Mr. W. Dance, gardener to Col. Lowe, Halstead, was second. Mr. Kettle also had the best six exotic Ferns, some of which had, however, been damaged by the post in transit. With a group of Chrysanthemums arranged for effect Messrs. Saltmarsh & Son, Chelmsford, were first with an excellent display, followed by Messrs. Unwin, Kettle, and J. Drew. Fruit, especially Apples and Pears, were well represented, and vegetables were also of good quality.

#### WIMBLEDON.—NOVEMBER 17TH.

THE annual Exhibition of Chrysanthemums, &c., in connection with the Wimbledon and District Royal Horticultural and Cottage Garden Society, was held at the Drill Hall on Thursday. Notwithstanding the lateness of the season and the inclemency of the weather, the Show was a good one, and certainly an improvement on that of last year. The groups were exceedingly fine, especially that arranged by Mr. Law, which included some handsome Palms, Bouvardias, double Primulas, and Maidenhair Ferns. In another class Mr. Ware exhibited some choice plants, and those shown by Mr. Smith and Mr. Chandler, which obtained second and third prizes respectively, were very fine. In the Chrysanthemum groups, arranged in 40 feet space, Mr. G. Stevens' exhibit, consisting chiefly of incurved and Japanese varieties, were much admired. The cut blooms in all the classes were large and compact, those shown by Mr. Gibson, Dr. Walker, and Mr. Stevens being very attractive. The fruit and vegetables shown were excellent, as were also the exhibits not for competition. Covering the entire front of the stage was a splendid miscellaneous group of plants exhibited by Messrs. D. S. Thomson & Sons of Wimbledon Nurseries, and which was highly commended by the Judges. The group included some magnificent Dracenas, Palms, Eucharis, Bouvardias, and Cyripediums, intermixed with Chrysanthemums, Roman Hyacinths, Primulas, &c., and it greatly improved the appearance of the Exhibition as a whole. The other free exhibits were a collection of thirty varieties of Apples, and three boxes of Potatoes shown by Mr. H. Alderman, gardener to G. Hatfield, Esq.; four stands of Chrysanthemums by Mr. Gibson, gardener to J. Wormald, Esq., of Morden Park; six dishes of Potatoes by Mr. Layzell; a handsome white wreath by Mr. Townsend of Putney; and cut Chrysanthemum blooms by Dr. Walker. The staging was arranged by Messrs. Lyne, Stratton, Dare, and Bridger. The Secretaries, Dr. Walker and Mr. Lyne, worked hard for the success of the Show, and to them the highest praise is due for the result.

#### BARNESLEY.—NOVEMBER 17TH.

THE first Show promoted by the Barnesley Paxton Society was opened on the 17th November by the Mayor, who was supported by the leading gentry of the town and neighbourhood. Being their first attempt the Committee resolved on a novel and effective method of ensuring the social success of the undertaking by forwarding admission tickets and inviting the members of the Town Council to the opening ceremony; thus an impetus was given to the movement which probably would not otherwise have been obtained. The open class was well filled with stands of flowers of excellent quality. Mr. W. Daniels, gardener to Mrs. T. Hagne Cooke, Hall Croft, Mirfield, was placed first for twenty-four cut blooms, twelve Japanese and twelve incurved, the Japanese being fresh and highly developed heavy blooms, and of the incurved the same may be said all through, not one indifferent flower in the stand. In the local classes for cut flowers Mr. G. Wright won seven first prizes with flowers of good quality, this section being rather weak after the first awards. Plants were shown of varying quality, some being fairly good and others leaving ample room for improvement. Five groups of Chrysanthemums staged for effect were shown, the first prize being easily won by Mr. John Henshall, Cemetery Road Nursery, with an excellent group made up of naturally grown and bush specimens, the whole forming a bright and effective group, free from the general stiffness noticeable in arrangements of this character, and it was a good example for the other competitors to copy. The Show was well attended, and gave much pleasure to the working classes, who previously had no opportunity of seeing what the Chrysanthemum is capable of as a decorative plant; and the Paxton Society well deserve the congratulations which were showered upon them, this being their second success this year, having during the past autumn right royally entertained the members of the Yorkshire Union of Horticulturists, and by their spirited action have given an impetus to gardening all through the district.

#### WILTS HORTICULTURAL.—NOVEMBER 17TH AND 18TH.

A SUCCESSFUL Chrysanthemum and Fruit Show was held by the Wilts Horticultural Society in the Market House, Salisbury, on the above dates. This being the second Show of the kind held in Salisbury, the Committee, including the popular ex-Mayor (Fred. Griffin, Esq.) and the indefatigable Hon. Secretary (Mr. W. H. Williams) are therefore to be congratulated upon the result of their efforts. The competition in most of the classes was good, and the exhibits were highly creditable.

GROUPS AND SPECIMEN PLANTS.—Three classes were provided for groups of plants arranged for effect in a semicircle of 10 feet by 6 feet, and 8 feet by 5 feet, and several good arrangements were put up. In the first-class, Mr. E. L. Brown, Portland Place, Fisherton, Salisbury, was first with a group of Chrysanthemums, finished off with Ferns and Pteridiums, the flowers small but plentiful and fresh. Mr. James Chalk, gardener to Mr. Read, Westwood, Wilton Road, Salisbury, was second, his flowers being better, but the front badly finished. Mr. A. C. Curtis, gardener to C. H. Radcliffe, Esq., Endless Street, Salisbury, was third with a group of miscellaneous plants. Mr. G. Inglefield, gardener to Sir John W. Kilk, Bart., Tedworth House, Marlborough, was first for a light and very effective arrangement, Calanthes, Cyripediums, Bouvardias, and Cyclamens being dotted about in a groundwork of Ferns. Mr. John Curry, gardener to Colonel Pepper, Milford Hill, Salisbury, was second for a good arrangement, but many of the foliage plants employed were too heavy for the purpose. Mr. John Hinxman, gardener to Mr. H. G. Gregory, The Island, Fisherton, Salisbury, was third. In the third group class (Chrysanthemums) Dr. F. W. Coates, St. John's Street, Salisbury, was first for a very good arrangement, finished off with well-flowered little plants of Chrysanthemums growing in 3-inch pots. Mr. Frank Pearce, High Street, Salisbury, was a good second, and Mr. Ambrose Tucker, Manor Road, Salisbury, third. With six specimen plants of Chrysanthemums Mr. James Chalk was first, and Mr. E. L. Brown was second, both showing only moderately good plants. Amateurs.—Mr. Macnamara, St. Martin's Church Street, Salisbury, was first, and Mr. C. J. Witcomb, Elm Grove, Salisbury, was second. With one trained specimen plant Mr. Frank E. Pearce was first with a good plant of Elaine; Mr. G. Inglefield was second with a good plant of Peter the Great, both showing flat trained plants; Mr. E. L. Brown being third with a well-flowered, balloon-trained plant of Elaine.

CUT BLOOMS (open).—These were shown well by Mr. Horsefield, gardener to Lord Heytesbury, Heytesbury, Wilts; Mr. Ward, Longford Castle, Salisbury; Mr. Inglefield, and Mr. Warden, gardener to Sir Frederick Harvey Bathurst, Bart., Clarendon Park, Salisbury; Mr. Horsefield being invincible in all the classes in which he showed. The chief class was for twenty-four blooms, to not include more than two blooms of any one variety. The three prizewinning stands were very close to each other in point of merit. Mr. Horsefield's first prize stand contained: (back row)—Maiden's Blush, Thunberg, Jeanne d'Alex, Meg Merrilies, Thunberg, Margaret Marrouh, Mr. J. Laing. Middle row—Bronze Queen, Empress of India, Lord Alcester, Queen of England, Golden Queen, Alfred Salt, Queen of England. Front row—Gold n Empress, Jardin des Plantes, Jeanne d'Arc, Mrs. Norman Davis, Jeanne d'Arc, Hero of Stoke Newington, and Princess Teck. Mr. Ward, who was second, was strong in Japanese. Mr. G. Inglefield was a good third, being also strong in Japanese. With twelve incurved, not less than eight varieties, Mr. Horsefield was to the front again with good blooms; Mr. Inglefield was second; Mr. Warden third with an even stand. With a like number of blooms of Japanese Mr. Horsefield led the way with solid blooms, being followed closely by Messrs. Inglefield and Ward in that order. With twelve blooms of reflexed, Mr. Copp, gardener to W. E. S. Drax, Esq., Holnest Park, Sherborne, was first with fine even samples of Cullingfordi, Golden Christine, and Garibaldi. Mr. Ward was a close second. Mr. R. West, gardener to — Wigram, Esq., Northlands, Salisbury, took first for twelve Anemone-flowered varieties, his best blooms being Fabian de Mediana, Empress, and Souvenir de L'Ardenne. Mr. Ward was a close second, and Mr. Inglefield was third. Amateurs.—In the class for eighteen blooms, not less than twelve varieties, Mr. John Voce (gardener, Mr. A. Williams) Church Fields, Salisbury, was first, and Mr. Tubb, gardener to Mrs. Ferryman, Redlynch House, Downton, was second. Mr. S. Melhuish, Sandford Street, Exeter, had the best twelve blooms of not less than six varieties, and Mr. J. Maynard, Wyndham Park, Salisbury, had the second best stand.

FRUIT.—Mr. Ward was first for a collection of six kinds of fruit with well-coloured Trebbiano and Gros Colman Grapes, Cayenne Pine, Lockinge Melon, Chaumontel Pears, and Ribston Pippin Apples. Mr. Warden was second, showing well-finished bunches of Black Alicante and Muscat of Alexandria Grapes, Salwey Peaches, &c. Grapes.—In the class for two bunches of Black Alicante there were only two exhibitors, Mr. Warden being easily first with good sized and grandly finished bunches; Mr. E. L. Brown was awarded a third prize. With two bunches any other black, Mr. Ward was easily first with two large and grandly coloured bunches of Gros Gnullaume. Mr. G. Richardson, Claylands, Salisbury, was second, showing two medium sized and beautifully coloured bunches of Gros Colman. Several lots were staged, including two small bunches of beautifully coloured Hamburgs. Several lots of Muscat of Alexandria were staged, Mr. Ward being a long way ahead with clusters of large and superbly coloured berries. Mr. James Chalk was second with thin bunches, consisting of very clean and beautifully coloured berries. Mr. Ward was again to the front in the any other white class with two large well coloured bunches of Trebbiano. Apples and Pears made a nice display, the first being clean and well coloured. With three varieties of the former (dessert), Mr. W. Scott, Bath Road, Exeter, was first with very good Cornish Aromatic, Cornish Giliflower, and Cox's Orange Pippin; Mr. G. Inglefield being a good second with Blenheim Pippin, King of the Pippins, and Cox's Orange Pippin. Ten good collections were put up. Five collections of kitchen Apples were sent red, Mr. Scott taking first place again with good fruits of Blenheim Orange, Dumelow's Seedling, and Beauty of Wilts; Mr. J. Pinckney, Great Durnford, was second. C. W. Gaer, Esq., Oakley, Millford, Salisbury, was first for three dishes of Pears with good fruits of Pitmaston Duchess, Napoleon, and Duchesse d'Angoulême, Mr. Warden being a good second.

NOT FOR COMPETITION, MISCELLANEOUS PLANTS.—Messrs. Keynes, Williams & Co. showed two good groups of Chrysanthemum plants, &c., on either side the entrance immediately inside the doors of the market house. These being tastefully arranged commanded a good deal of attention from visitors, as also did six buttonhole bouquets made by Lady Hulse, Breamore House, Salisbury, and two large clusters of Black Alicante Grapes from Mr. Charles Warden, and carrying a fine bloom, attracted a good deal of attention, as also did a Corfu Melon exhibited by the Earl of Radnor, who received it from Malta a few days before the Show. Mr. Horder, Millford Hill, Salisbury, and Mr. Ward showed some good stands of cut Chrysanthemum blooms. The classes for exhibits from ladies were also well filled.



## HULL—NOVEMBER 17TH AND 18TH.

LARGE as are the Artillery Barracks in which the Hull and East Riding Chrysanthemum shows are held, additional space had to be provided this year for the accommodation of the products and visitors, an annexe 100 feet long, and 30 or 40 feet wide being specially erected by the Committee. The schedule was divided into forty-seven classes, the aggregate value of the prizes, including four silver cups, amounting to about £200, and nearly 500 entries were made; though, as is always the case, some intending exhibitors failed to stage their produce, yet sufficient was forthcoming to make a great and good show. An imposing display was made by the groups, specimen plants were greatly in advance of those at previous shows, and never before has the average quality of the cut blooms been so high at Hull; while in the special class Mr. Mease surpassed all previous exhibits that have been staged in competition for the challenge cup, which he won with comparative ease, and it is safe to say that no prize was ever handed to an exhibitor with more pleasure than this was by the Committee of the Show in question. Before enumerating his blooms brief reference must be made to the plant department of the Show.

**GROUPS.**—A silver challenge cup, value 10 guineas, was offered by the Committee with the first prize of £10, in the open class for groups of Chrysanthemums arranged for effect with foliage plants in a space of 100 square feet, the remaining prizes being £4, £3, and £2. Six oval-shaped groups were arranged at convenient intervals in the body of the main building, protected by strong barriers. The premier position was won by Mr. J. P. Leadbetter, gardener to Arthur Wilson, Esq., Tranby Croft. The central plant was an elegant Cocos, rising about 9 feet high, around which admirably grown Chrysanthemums were tastefully disposed, many bearing exhibition blooms, lightly interspersed with fine-foliaged plants, margined with Ferns and Crotons—a bright, cheerful and most creditable arrangement. Mr. G. Cottam, jun., florist, &c., Cottingham, was second with a very similar and excellent group, but the margin of Palms, &c., too broad at the sides of the oval. Mr. W. Mason, gardener to Lieut.-Col. Brooshooff, Kirkella, was third with a massive group of well-grown Chrysanthemums, but a little relief was wanted, and the margin was rather weak. Fourth honours were adjudged to Mr. G. Jarvis, gardener to B. Whittaker, Esq., Hessle, for an arrangement similar in character to the first and second groups. Mr. H. H. Taylor, Newland, Hull, was highly commended for a very rich assortment of Chrysanthemums, but rather too closely packed. In the amateurs' class for groups covering 50 square feet, Mr. A. W. Stanley, Midland Street, Hull, and Mr. S. Higham, Hessle, were the only exhibitors, and were awarded the prizes in the order named, both exhibiting well. These eight groups, with an extensive, rich, and varied assortment of Chrysanthemums and other plants arranged in front of the orchestra by Messrs. E. P. Dixon & Sons, produced a striking effect, and evoked expressions of admiration from visitors.

**PLANTS.**—Though a decided improvement was manifest, the plant classes were the weak part of the Show. The greatest display was made by plants not formally trained, or, to quote the schedule, "the stems not depressed or bent down, but the shoots tied to stakes for support, to produce an evenly balanced bush." In the class for six plants, Mr. A. Thompson, gardener to J. Miller, Esq., Hessle, was easily first with specimens 3½ feet high, each having about thirty blooms of fair quality; second, Mr. J. H. Thompson, gardener to John Fisher, Esq., Manor House, Willeby; third, Mr. W. Mason, Kirkella, with still larger and healthy plants, but smaller blooms. Several others competed well in this class, but many of the plants would have been better if disbudding had been more freely indulged in. In the class for three trained plants, Mr. J. S. Graham, gardener to George Lawson, Esq., Newland Grove, Hull, well won the first position with beautifully trained symmetrical plants, 2½ feet high, bearing thirty to forty blooms of excellent quality, the foliage correspondingly good. The right stamp of training was evident, the stems being bent at the bottom, not near the blooms, rendering the twisting objectionable. Local growers may take the plants named as the correct type of trained specimens, and defeat Mr. Graham if they can next year; in the meantime he has our congratulations, for with the exception of some samples procured by Mr. R. F. Jameson last year and staged as "object lessons," no such specimens have been seen at Hull. The second prize was awarded to Mr. J. A. Thompson, for very well trained but rather too flat Pompons, by far the best of their kind, however, yet seen in the Society's shows. Third honours were adjudged to Mr. Mason for standards, also excelling others at previous exhibitions. These exhibitors were successful in other classes. The plants staged by amateurs were better than on any previous occasion. The great pressure on space prohibits an enumeration of the prizewinners.

**CUT BLOOMS.**—The greatest interest naturally centred in the challenge vase competition, and as above indicated the Judges had no difficulty in placing Mr. W. Mease in the foremost position, and he accordingly secured the trophy and 15 guineas. Mr. J. P. Leadbetter, gardener to A. Wilson, Esq., Tranby Croft, Hull, gained the second award of £10; and Mr. James Coultas, gardener to W. Harding, Esq., Holly Hurst, Darlington, the remaining prize of £5. Mr. Mease staged an extra fine collection; there was scarcely a faulty bloom in the stand, while many of the incurved were of large size and depth, the florets being remarkable for width, especially of the Queen family, and all were fresh and bright. The following are the names of the varieties staged, reading in each case from the left-hand corner. Incurved.—Back row—Queen of England, Lord Alcester, Alfred Salter, Empress of India, Golden Empress, Lord Wolseley, Queen of England. Middle row—Jeanne d'Arc, Mr. Bunn, very large; John Salter, fine; Golden Empress of India, Prince Alfred, Empress of India, Princess of Wales, John Salter. Front row—Empress Eugenie, Mrs. Heale, Princess Beatrice, Refulgence, Mrs. Heale, Hero of Stoke Newington, Cherub, Lady Harding. Japanese.—Back row—Madame C. Audigier, Fair Maid of Guernsey, Boule d'Or, Triomphe de la rue des Châlets, Fair Maid of Guernsey, Margaret Marrouch, Golden Dragon, Madame C. Audigier. Middle row—Japonaise, Belle Paule, Meg Merrilies, Jean Délaux, Ralph Brocklebank, Madame J. Lainy, Meg Merrilies, Triomphe de la rue des Châlets. Front row—Madame Blanche Pigny, Criterion, M. Freeman, Mdle. Lacroix, Annie Clark, Soliel Levant, Val d'Andorre, Elaine. Mr. Leadbetter was strong with Japanese, having some larger and finer flowers than Mr. Mease, but had three or four weak blooms in his stand. The back and middle rows of his incurved were strong with one or two exceptions,

while the front row was comparatively weak. The cup and prizes were given for forty-eight blooms, twenty-four Japanese and twenty-four incurved, not less than eighteen distinct varieties of each.

In the class for twenty-four blooms, twelve Japanese and the same number of incurved, not less than nine varieties of each, Mr. W. Mease again well won the first position. Mr. G. Lofley, Kington, Leicester, was placed second with small but neat incurved blooms, and very fair, bright-coloured Japanese. Mr. G. Cottam, gardener, Alma House, Cottingham, was the remaining prizewinner. For twelve incurved blooms, distinct, Mr. Mease was again first, showing in his usual style large fine blooms. Mr. W. Ashley, Lunefield House, Lincoln, was second with small but neatly dressed flowers. In the corresponding class for twelve Japanese Mr. Mease was once more first with an excellent stand of large, fine flowers, Mr. W. Ashley being second with much smaller but very neat blooms. For twelve large hybrid Anemones, not less than six varieties, Mr. F. Mason, gardener to G. Bohn, Esq., Tanby Park, Hessle, was placed first with a capital lot of flowers of Madame Cabrol, Sœur Dorothee Souille, Madame Villageoise, Madame Clos, Madame Berthe Pigny, and Fabian de Mediana. Mr. Dearing, gardener to F. W. Jameson, Esq., Eastella, Hull, was a close second. In the corresponding class for twelve Mr. J. A. Thompson, gardener to John Fisher, Esq., took the lead with fresh, neat, well-developed blooms, Messrs. Dearing and F. Mason being second and third respectively. For twelve reflexed Mr. Dearing was first with King of Crimson, Dr. Sharp, Pink Christine, Chevalier Domage, Madame Madeline Tezier; Mr. J. A. Thompson second, and Mr. J. Hare, gardener to J. A. Hudson, Esq., Beverley, third. For six blooms, one variety only, Mr. Wm. Mease was well first with large handsome blooms of Queen of England, followed by Mr. Dearing with Mdle. Lacroix very fine; third, Mr. G. Lawson, Newland Road. For twelve bunches of Pompons with foliage, three blooms of each, Mr. W. Wilkinson, gardener to Mrs. Ross, Elloughton Lodge, took the lead with a capital stand. For twelve bunches of single varieties, with foliage as cut, Mr. Dearing was the only exhibitor, and was deservedly awarded the first prize. For the best collection of cut blooms, any varieties, in a space 16 feet by 18 inches, to be set up in any style the exhibitor chooses, for nurserymen only. This class has principally been designed to bring out new and worthy decorative varieties. Two competitors only entered, and the premier position was awarded to Mr. T. B. Morton, Mowden Bridge Nursery, Darlington, who staged his flowers in bunches with foliage, and the display was very effective. Mr. Cottam was given the second award, but his flowers were staged singly on stands in the usual way.

The next four classes were open only to those residing in Lincolnshire within twenty miles of Hull, or anywhere within the East Riding of Yorkshire. For twenty-four blooms, twelve to be incurved, in not less than six varieties, and twelve to be Japanese, not less than six varieties, the first prize of £3 3s. was given by Mr. E. P. Dixon, seedsman, Queen Street, Hull. To this R. Falconer Jameson, Esq., who elected to take the testimonial presented to him on his retirement from the office of joint Hon. Secretary in the shape of a silver challenge cup, allowed it to accompany the first prize in this class. The cup is valued at 10 guineas and given under the same conditions as the one in the class for forty-eight blooms. Mr. J. P. Leadbetter was the successful competitor, followed closely by Mr. J. A. Thompson and Mr. Dearing. A protest was laid against the decision of the Judges by the employer of the second prizewinner, and the Judges went over the stands again, only to confirm their first decision. Mr. Leadbetter was first by about five points; his incurved blooms were not so large as those of the second collection, but they were compact, firmer, and of better quality. He also led a point or two in the Japanese. There is no question about the Judges' decision being right, for several well-known Chrysanthemum growers who were consulted gave their decision the same as the Judges. For twelve blooms, incurved, not less than six varieties, first prize given by Messrs. Clark & Sons, Queen Street, Hull, Mr. F. White, gardener to H. H. Briggs, Esq., took the lead with small but neat flowers, followed by Mr. F. Mason and Mr. J. A. Thompson. For twelve Japanese Mr. J. S. Graham was first with a capital lot of flowers, followed by Mr. J. A. Thompson, who had neat examples; third Mr. F. Mason. There was good competition in this class. In the class for twelve blooms, six Japanese and six incurved, first Mr. J. S. Graham; second Mr. R. Walker, gardener to Colonel Citherow, Hotham Hall; third Mr. F. White. For the best stand of blooms in classes 24 for twelve incurved and 25 for twelve Japanese, any varieties, a silver cup value 8 guineas was offered by the Hull Amateur Floral and Horticultural Society, in addition to the money prize, and given on the same conditions as the two previously mentioned. In each of the classes Mr. A. W. Stanley, Midland Street, Hull, was first, and was awarded the cup for his stand of incurved blooms. Mr. John Horsey, Anlaby Road, Hull, was second in each class. The remaining classes, about ten in number, were principally devoted to six blooms of different kinds, and the prizes offered were well contested. Throughout this portion of the Exhibition great strides have been made since last year, and it is clear that many of the local growers will soon be capable of entering in the principal classes of the Exhibition. For the premier incurved bloom in the Show Mr. J. R. Leadbetter was first with Empress of India. For the best Japanese Mr. Morton, nurseryman, Darlington, was successful with a large bloom of Edwin Molyneux. In the amateurs' class Mr. A. W. Stanley was first for a fine flower of Queen of England.

**BOUQUETS.**—These were generally too much packed. Some ten exhibits were staged for the three prizes offered for a bouquet of Chrysanthemums arranged with any kind of foliage. Mr. G. E. Smith, Floral Cottage, was first, a handsome arrangement of white flowers with a few red leaves round the edge, and Adiantum cuneatum and Asparagus plumosus arranged amongst the flowers and at the outer edge. Mr. H. H. Taylor, Newlands, Hull, second; and Mr. Cottam third.

**CERTIFICATES.**—Mr. Morton, nurseryman, Darlington, was granted a certificate of his bloom of Edwin Molyneux, and the same award was made to Messrs. H. Cannel & Sons, Swanley; also for Mr. C. Orchard, Mr. H. Cannel, and Lady Churchill, a single quilled chestnut-coloured variety.

**MISCELLANEOUS EXHIBITS.**—Mr. R. J. Watton, Newland Toft Nurseries, Hull, contributed a collection of Zonal Pelargoniums in bloom; Mr. G. Cottam Ferns and small Palms; Messrs. H. Cannel & Sons collection of cut blooms of Zonal Pelargoniums and Chrysanthemums of various kinds; Messrs. E. P. Dixon, nurserymen and seedsmen, Hull, a splendid collection

of Apples and Pears grown at their Burton Constable Nurseries, also Heaths, Solanums, Potatoes, and Turnips, these exhibits contributing powerfully to the interest and attractiveness of the Exhibition.

#### READING.—NOVEMBER 18TH.

A FIRST-RATE Exhibition distinguished the fourth annual autumn gathering at Reading, and the progress made since the last Show was satisfactory in the highest degree. In numbers the exhibits far exceeded any of the preceding exhibitions at this town, while the quality was above the average of the present season. Cut blooms, specimen plants, groups, Apples, Pears, and Grapes were admirably represented, and in the majority of the classes the competition was sufficiently keen to give the Judges more than ordinary difficulty. Most unfortunately the weather proved exceedingly unfavourable, sleet and rain descending during the greater portion of the afternoon, and this materially lessened the receipts at the doors.

The Show was held in the old and new Town Halls, both spacious halls being well filled with exhibits. In one the groups and specimen plants were arranged near the walls and on an elevated platform at the end, the cut blooms and table plants occupying the centre of the hall. In the other hall most of the fruit was staged, some also occupying tables in the corridors, the extensive collections of Apples from Messrs. Bunyard & Co., Maidstone, being the most conspicuous.

**CUT BLOOMS.**—There were numerous competitors in several of the leading classes, and the stands required considerable space. There were eleven entries with twelve incurved, W. G. Marshall, Esq., Taunton (gardener, Mr. Thomas), winning first honours with even, deep substantial blooms. C. Crew, Esq., Bilingbear Park; Col. the Hon. W. P. Talbot, Esher (gardener, Mr. Waite); and Dr. Lewis, Henfield, Sussex (gardener, Mr. Russell), secured the other prizes. F. W. Flight, Esq., Twyford (gardener, Mr. Neville), had the best twelve reflexed amongst nine exhibitors, very handsome blooms and fresh. Dr. Lewis exhibited well in several classes, and was first with twelve large Anemones, two competitors in the same class being disqualified for including Japanese Anemones. There was a remarkably keen competition with twelve Japanese, fifteen admirable stands being entered, Mr. Thomas gaining the first place with fine fresh richly coloured blooms. Mrs. J. Dunning Smith, Ascot, and Dr. Lewis were the other prizewinners. An interesting class was that for twelve cut blooms in eight varieties, Pompons excluded, to be shown as grown, with not less than 9 inches of stem above the board, but it would have been better if confined to either Japanese or incurved, as these when together rather detracted from each other's beauty. The Japanese had a particularly good appearance in this way, as the full depth of the blooms could be seen. C. Crew, Esq., was first with uncommonly good blooms of Belle Paule, Soleil Levant, and J. Delaux. There were thirteen exhibitors in the class, Messrs. Allen and Lees taking second and third prizes.

The specimen plants included six extremely fine Japanese from C. H. Witherington, Esq., Sonning (gardener, Mr. Surman), with which the chief prize in the class was easily won. They were dwarf, about 4 feet in diameter, very even and profusely flowered, the varieties being James Salter, Elaine, La Charmante, La Nymph, Peter the Great, and Bouquet Fait. R. Tompkins, Esq., Reading (gardener, Mr. Booker), followed with taller plants. The same exhibitor (Mr. Surman) took first honours in several other classes with equally well grown specimens. A number of groups were entered, and the prizes were won by S. B. Stevens, Esq., B. Simonds, Esq., W. J. Palmer, Esq., Mrs. Marsland, and J. Leslie, Esq., in the order named.

Of the fruit the Grapes were an important feature, Mr. Perkins, gardener to the Right Hon. W. H. Smith, Henley, showing extremely well. He had the best two bunches of Alicante amongst eleven exhibitors, very large bunches admirably coloured. C. Hoare, Esq., Hackwood Park (gardener, Mr. Bowerman), was second, also with good samples, and Sir E. Colebrook, Bart., Chertsey (gardener, Mr. Osman), third. With three bunches of Gros Colman Mr. Jennings, Farnborough Grange Gardens, and Mr. W. Iggulden, Marston Gardens, Frome, were the prizewinners in the order named, and very close in merit. In the Muscat class Mr. Woolford led with Bowood, small bunches but highly coloured, Mr. Perkins being second with very handsome bunches, clean and good, but not quite so finely coloured as the first. For two bunches of black Grapes, Mr. Perkins won the chief place for beautiful examples of Alwick Seedling; Mr. Bowerman taking similar honours in the white Grape class with Mrs. Pearson in excellent condition, Mr. Turton being second for Trebbiano.

Mr. Perkins had the best collection of fruit, good Grapes, Apples, Pears, Bananas, and Plums, Messrs. Allen and Turton following. Mr. Turton was, however, first with six dishes of dessert Apples, extremely handsome specimens of Rosemary Russet, Adam's Pearmain, Scarlet Nonpareil, Blenheim Pippin, King of the Pippins, and Cox's Orange Pippin. Mr. Ross, Welford Park Gardens, was a close second; and Mr. R. Webb, Benham, third. Messrs. Ross, Irvine, and Turton were the prizetakers with six kitchen Apples, all showing fine fruits, while in the two other classes Mr. Ross had the best Blenheim Pippin and Mr. Turton the best Scarlet Nonpareil. Messrs. Trinder, Irvine, and Turton were the chief exhibitors of Pears.

#### SHEFFIELD AND WEST RIDING.—NOVEMBER 18TH AND 19TH.

The above Society held their third annual Show in the Corn Exchange on the 18th and 19th inst. The building is a spacious one and well adapted for an exhibition of this nature. On the whole the Show was a decided success, and considered to be in many respects superior to its predecessors.

**CUT BLOOMS.**—The main attraction centred in the open class for forty-eight blooms, twenty-four incurved and the same number of Japanese, not less than eighteen varieties of each. A silver cup value £15 15s. and £10 was given as the first prize, £10 for the second, and £5 for the third. The cup was given by the Hon. Treasurer, Mr. H. Broomhead, Leopold Street, a gentleman who takes great interest in Chrysanthemums, and is anxious to see this Society second to none in the kingdom. There were no less than nine entries for the cup class, but only three collections staged. Mr. Parker, gardener to John Corbett, Esq., M.P., Impney Hall, Dorking, was successful in securing the premier position with excellent blooms of both incurved and Japanese. Mr. Mease was only a few points behind. The third prize was awarded to Mr. Midgley, gardener to H. Mason, Esq., Bankfield, Bingley, Yorks, the competition being extremely close throughout. The third col-

lection contained the brightest and best Japanese, but the incurved were somewhat irregular. The varieties were as follows in the first prize collection, commencing with the incurved at the lefthand corner:—Back row—Lord Alcester, Jeanne d'Arc, Lord Alcester, Queen of England, Empress of India, Queen of England, Empress of India, John Salter. Middle row—Golden Empress, Lord Wolseley, Jeanne d'Arc, Bronze Queen, Alfred Salter, John Salter, Jeanne d'Arc, Nil Desperandum. Front row—Cherub, Refulgence, Hero of Stoke Newington, Mrs. W. Shipman, Mrs. Heale, Mrs. N. Davis, Barbara, Princess of Teck.

**JAPANESE.**—Back row—Boule d'Or, Belle Paule, Triomphe de la rue des Châlets, Baronne de Prailly, Thunberg, Triomphe de la rue des Châlets, Meg Merrilies, Baronne de Prailly. Middle row—John Laing, Duchesse of Albany, Meg Merrilies, Thunberg, Madame J. Laing, Carew Underwood, Belle Paule, Fair Maid of Guernsey. Front row—Criterion, Sonree Japonaise, Jeanne Delaux, Stanstead White, Val d'Andorre, M. Burnet, Jeanne Delaux, L'Adorable.

For twelve incurved, not less than nine varieties, Mr. W. Mease was well first, Mr. Midgley second with a capital lot, and Mr. W. Gill, gardener to Mrs. Oldman, Summer Hill, Gainsborough, third. In the corresponding class for twelve Japanese, the prizes went to the same exhibitors, as they also did for six incurved blooms in two varieties. In the corresponding class for six Japanese Mr. Midgley was first with Val d'Andorre and Madame Lacroix; Mr. Mease second with Meg Merrilies and Jeanne Delaux; Mr. W. Gill and Mr. A. Bnsh were both placed third. For the premier bloom in the show Mr. Mease was successful with a grand Queen of England in the class for forty-eight blooms.

The following classes were limited to growers within a radius of seven miles of Sheffield. For twelve incurved, distinct, Mr. W. K. Woodcock, gardener to Mark Firth, Esq., Oakbrook, was first with very good and neat examples; and Mr. E. Pidsley, gardener to Mrs. H. Wilson, Westbrook, second. In the corresponding class for twelve Japanese the last competitor was successful with neat flowers, Mr. Woodcock second, and Mr. Allan, Traveller's Rest, Langsett Road, third. For six incurved blooms Mr. E. Pidsley took the lead. For six Japanese the same exhibitor was first, and also for six large Anemone flowered, not less than four varieties. For six reflexed Mr. Woodcock took the lead of Mr. Pidsley. In the amateurs' classes for twelve incurved blooms, distinct, Mr. H. Broomhead, 39, Leopold Street, the gentleman who gave the challenge cup, was deservedly first with well finished examples. Mr. J. Harrison was placed second. In the corresponding class for twelve Japanese those exhibitors held the same relative positions. For six blooms incurved Mr. Carmel took the lead, followed by Mr. J. Baines. For six Japanese Mr. Grubb was first. In the smaller amateurs' classes many of the blooms equalled in dressing and finish those of Messrs. Sanderson and Molyneux. Bouquets were well represented, but the quality on the whole was not first class.

**PLANTS.**—For six trained specimens Mr. Jos. Walker took the lead with specimens from 2 feet 6 inches to 3 feet high, well furnished with foliage, but the blooms rather small; the National Society's certificate for the best plant in the Show was rightly accorded to a plant in this collection. For three trained plants, also for six Pompons, the same exhibitor was again first with creditable specimens; Mr. E. Pidsley was second with plants 3 to 4 feet high, grown as bushes. Groups of Chrysanthemums were three in number, arranged for effect, Ferns and other plants being used as an edging for a depth of 18 inches. Mr. Jos. Walker was placed first with the lightest group. Mr. E. Pidsley second with a larger, stiffer, and more formal arrangement; some considered this should have been first, and no doubt it should if "effect" were ignored and a mass of colour the object to be attained. Mr. J. Harrison was third, having decidedly the best flowers, but his group had never been finished. Three or four tastefully arranged groups of stove and greenhouse plants were contributed, Mr. E. Pidsley's was first with the lightest and by far the most effective. Mr. W. Collier was second, but his exhibit was rather too heavy. Table plants were not numerous, but the examples staged were very light and even throughout. Mr. Pidsley was first for six plants, followed closely by Mr. J. Foggin, gardener to Mr. G. Wilson, with slightly larger plants. Third, Mr. W. Collier.

**FRUIT.**—Two classes were provided for Grapes, and the competition was limited in each case. For two bunches of black Mr. Midgley was first with Mrs. Pince; Mr. G. Staples, Glapwell Hall, Chesterfield, second with Gros Colman; Mr. A. Malcolm, gardener to J. Y. Cowlishaw, Esq., Saption Cliffe, third. For two bunches of white Grapes Mr. Midgley was first with well-coloured Muscat of Alexandria; Mr. Staples second.

**Miscellaneous Exhibits.**—Messrs. Fisher, Son, & Sibray, staged excellent stove and greenhouse plants, also Conifers, as well as a large collection of Apples and Pears. Messrs. Hiram Shaw & Son, Richmond Hill Nursery, Sheffield, Gros Colman, Barbarossa, and Alicante Grapes, also Apples, Pears, wreaths, Palms, Roman Hyacinths, and foliage plants. Mr. Udale contributed a very praiseworthy collection of Apples and Pears; amongst them a dish of Red Currants in excellent condition was very noticeable. On the second day of the Show Mr. Mease's blooms from Hull were on view and attracted much attention. Certificates were awarded to Mr. T. Winkworth for Ralph Brocklebank, and to Mr. W. K. Woodcock for the new yellow reflexed American variety, Gorgeous. The Show was well attended and a financial success is anticipated.

#### WOKINGHAM.

**CHRYSANTHEMUM** exhibitions are now very numerous, almost every town of pretension considers its horticultural section incomplete without a Chrysanthemum show. Wokingham in this respect is not behind the times, and held a very good Exhibition of this favourite autumn flower last week. In the open class for twenty-four distinct, twelve incurved and twelve Japanese, for which substantial money prizes were offered, there were seven collections staged. Mr. W. Wildsmith, gardener to Lord Eversley, was awarded first honours for a highly meritorious collection all the Japanese being good, while the incurved were in some instances small, but neat and fresh. The varieties comprised—in Japanese, Thunberg, Madame C. Audiguier, Soleil Levant, Triomphe de la rue des Châlets, Meg Merrilies, Japonais, Madame de Pigny, Ralph Brocklebank, Henri Jacotot, Blanche Neige, Val d'Andorre, La Triomphante. Of incurved the following were notable:—Queen of England, Lord Alcester, Emily Dale, Jeanne d'Arc, John Salter, Golden Empress, Empress of India, Beauty,



Princess Teck, Barbara, Pink Venus, and Nil Desperandum. Mr. T. Ashman took the second prize with larger incurred flowers, but a few of them very rough. Mr. W. Lane, gardener to E. Lawrence, Esq., King's Ride, Ascot, was awarded the third position. All the collections were very close; indeed, there were only a few points between them. Several groups furnished the sides of the Hall, the best coming from Mr. Sinclair, gardener to the Marchioness of Downshire, East Hampstead Park, Wokingham. Mr. Ashman made a very good second, and Mr. Wilkes, gardener to J. C. Heathcote, Esq., Filly Court, Wokingham, third. For six specimens the prizes fell to Messrs. Ashman, Goddard, and Wilkes in the order of their names. The principal amateur exhibitors were Mr. Caiger Heffer, Mr. Hostler, and Mr. Bedford. Among cottagers, Messrs. Parsey, Couderey, and Lewis exhibited well. Both fruit and vegetables were very numerous represented and of high-class order, being seldom met with so good.



### FRUIT FORCING.

**PINES.**—Well ventilated span or three-quarter span-roofed pits or small houses properly ventilated are the most suitable for small stock, which at this season often suffer irreparable injury from being kept too close and warm, the plants being drawn and weakly. At night 65° should not be exceeded, but a mean between that and 55° at night, which, with 65° in the daytime, will keep all young stock gently progressing, admitting a little air at the top of house at 65°, leaving it on all day, but not to lower the temperature below that point, and when the sun raises the temperature to 75° a free circulation of air should be allowed. Keep the bottom heat steady at 80°, avoiding anything approaching to a damp atmosphere, moderate humidity will suffice. Apply water only when the plants become dry, and then give weak liquid manure. Keep the plants near to the glass and allow them plenty of room.

Suckers ready for starting now may be kept until March, and if there is likely to be a scarcity of suckers, any recently potted may be retained in 5-inch pots, affording them a light position in a moist pit, with a slight bottom heat and a temperature of 55° at night, keeping them rather dry at the roots. In the fruiting department 65° will be ample at night, 5° lower in the morning in cold weather, 70° to 75° by day. Take every opportunity of collecting leaves whilst dry, Oak and Beech being the best, and whenever a favourable opportunity offers push forward whatever may be necessary in the renewing or augmenting the fermenting beds.

**FIGS.**—*Earliest Forced Planted-out Treces.*—The earliest house, or that with the trees in inside borders, should now be closed with a view to having ripe Figs in May, but where the earliest Figs are had from trees in pots starting of the trees planted in borders may be deferred until the new year, so as to afford a succession. Yet if the trees planted out be now started they will afford a closer succession to those now being forced in pots. Water in a tepid state should be applied to the roots at frequent intervals until the soil is thoroughly moistened, introducing thoroughly sweetened leaves and stable litter in ridge form into the house to produce a moist genial condition of the atmosphere, and induce gentle excitement, as well as to economise fire heat. Commence with a temperature of 50° at night, 55° by day, and 65° from sun heat, syringing the trees and every available surface in the morning and early in the afternoon, unless the weather be dull and cold, when the morning syringing only should be practised. Admit air moderately whenever the weather is mild, closing the house with sun heat at 65°, or if it exceed that with full ventilation close the ventilators when the sun heat begins to decline.

*Earliest Trees in Pots.*—These must not be hurried by too much bottom heat, but as the fermenting material settles more should be added and pressed firm, being very careful not to allow the heat about the pots to exceed 65°. When the buds are swelling freely the temperature may be increased to 55° at night, 60° by day by artificial means, admitting a little air at that, and allowing an advance to 70° or 75° by sun with corresponding ventilation, closing at 65°. Sprinkle the trees and house morning and afternoon, or in the morning only if the weather be dull.

*Preparing Trees for Early Forcing.*—Young trees intended for forcing in pots another season should be shaken out and repotted, starting them into growth shortly or at once, so that they may make the necessary growth and complete it early, so as to have time to rest before being forced for fruiting. Brown Turkey, White Marseilles, and Negro Largo are excellent varieties.

**PEACHES AND NECTARINES.**—*Earliest House.*—When the buds have commenced swelling maintain a temperature of 40° to 45° at night and 50° to 55° by day, admitting air moderately at the latter figure, allowing the temperature to rise to 65° from sun heat, syringing the trees and every available surface morning and afternoon until the bloom buds are showing colour, after which the syringing may be discontinued, but sprinkling the house, walls, and paths may be continued as before. There must be no attempt at a close atmosphere, but allow a little air at the top of the house to lessen the condensation of moisture by the glass. The inside border will require to be supplied with water slightly

warmer than the mean of the atmosphere, maintaining the soil in a thoroughly moist state. Borders inside require careful watering, making sure that every part of the soil is thoroughly moistened. Outside borders will be benefited by lights or shutters in addition to a covering of bracken or litter for throwing off heavy rains and snow.

*Houses to Afford Ripe Fruit in May or Early June.*—The house should be closed early in December, but no fire heat should be applied except to exclude frost, and for an hour or two in the early part of the day if the weather be severe; not, however, exceeding 50° by fire heat in the daytime, syringing the trees and every available surface morning and afternoon. A ridge of thoroughly sweetened dung and leaves placed in the house after the border is well moistened will afford a genial atmosphere superior to that obtained from hot-water pipes, admitting air whenever the weather permits, Peaches delighting in a well-sweetened atmosphere.

*Succession Houses.*—Push forward the pruning, thoroughly cleansing the glass and woodwork, whitewashing the walls, and dressing the trees for the destruction of insects. Secure the trees to the trellis, top-dress the borders, and keep the house cool by ventilating abundantly in mild weather. If the roof lights are moveable and off by all means let them remain so until the time arrives for starting the trees. No frost will injure the wood if it be ripe, and if not ripe satisfactory crops are not obtainable.

### PLANT HOUSES.

**Gardenias.**—Plants that are swelling their flower buds must not be kept in a lower temperature than 65° if they are to swell properly. Be careful not to give too much water, this will bring about deformity of the flower buds. If carefully supplied with water the same temperature as the house, and artificial manure is applied in small quantities to the surface of the soil at intervals of two or three weeks, the roots will continue active and the flower buds develop naturally. Those that are first showing their flower buds and intended for spring flowering will do very well in a temperature 5° lower, provided they are not kept too wet at their roots. Young plants in 2-inch pots intended for growing on early in the year should be placed in the first named temperature so that they can be kept slowly advancing. Pinch out the points of the plants to prevent their running up tall. Keep these plants close to the glass, but be careful that the soil does not become dry about their roots.

*Medinilla magnifica.*—The growth of this plant should be completed, but, to further ripen it and insure a thorough season's rest, remove it from the stove to an intermediate temperature, the atmosphere being kept drier, and less water should be given to the roots. Keep the soil on the dry side, but do not allow the roots to perish by giving an insufficient supply. While under these conditions this plant is very liable to the attacks of thrips, which, if not destroyed, will quickly injure its large beautiful foliage. The best and quickest method of destroying thrips is to syringe the plant thoroughly with a solution of tobacco water.

*Anthurium Schertzerianum.*—All plants that have completed their growth may be removed from the stove to any structure where an intermediate temperature can be maintained. They are ready for removal at any time after the foliage is fully developed. While under cooler treatment give the plants less water at their roots, or else they will perish. By giving them a good season of rest under such conditions they will be found to grow with increased vigour another season and flower with greater freedom than if kept in the stove the whole year round.

*Anthurium Andreanum.*—The supply of water to the roots of this plant should be slightly diminished. If kept in the stove it will continue to flower the whole season. On this account it is invaluable and conspicuous during the winter.

*Impatiens Hawkeri.*—Give those first coming into flower as light a position in the stove as possible, where they will not be subjected to too much moisture on their foliage from the syringe. Keep young plants in 2 and 3-inch pots close to the glass in a temperature of 60°. When ready the points may be removed to induce them to branch. Under this treatment they will grow strongly and make grand plants for early spring flowering if placed when ready into 5 and 6-inch pots. Use for a compost loam, one-seventh of manure, and a little sand. Press the soil firmly into the pots, this will prevent a soft rapid growth which results from loose potting and the use of leaf mould amongst the soil. I. Sultan may also be allowed to come into flower. Pinch later plants for succession, and place sturdy seedlings now in 2-inch into 4-inch pots. If these are grown close to the glass and not too warm they will be very useful when the bulk of the winter flowering plants are over.

*Begonia Ingrami.*—Bushy plants in small pots that have broken into fresh growth since they were pinched may be given a small shift at once and allowed to come forward into flower. These plants will be ready for the stove by the time Poinsettias, Euphorbias, and other similar plants are getting over. These plants will do well on a shelf where the temperature does not fall below 55°. Pinch when needed plants in 3-inch pots that were rooted six weeks ago, and keep them in this size until early in January, when they may be placed into others 2 inches larger.

*Begonia nitida.*—This and its varieties may be placed into 5-inch pots when ready for spring flowering. It is a mistake to place these kinds into too large pots in autumn, for they do not flower freely before February. If placed in their flowering pots between now and January as they become ready they will be invaluable for the stove until mid summer.



## THE BEE-KEEPER.

### PRACTICAL BEE-KEEPING.—No. 23.

ONE of the most important matters in connection with the practical management of an apiary still remains for our consideration. True, the systems and some of the principles of supering have been considered at various times by many writers of vast experience, and in former papers of the present series more than a passing allusion has been made to the best method of obtaining a large surplus either of comb or extracted honey. All the care and attention bestowed on stocks are with a view to preparing them for the honey flow; it is therefore most desirable for every bee-keeper to know in what way he may obtain most surely—taking one year with another—the largest possible saleable surplus from each of his stocks.

In my opinion, based upon considerable experience, the tiering system, or some modification of that system, should be adopted in all cases and under all circumstances. Whether we desire to prevent the issue of a swarm or not, the tiering system is the one which should be adopted if we desire to obtain the largest possible surplus in the most saleable form. In some localities where the honey flow is brief, in some seasons when the weather is unfavourable, the usual tiering method must be considerably modified to suit the season and other circumstances, but the principle underlying the system should still be followed.

This principle is that bees work better in a super gradually enlarged than in a large space provided from the first. Most bee-keepers are aware that bees are often unwilling to commence operations in a large super with a capacity for holding 100 lbs. of honey, and yet may easily be induced to store a greater weight if space is given by adding fresh supers as the bees become crowded. The old plan was to place a super on a stock and leave it there until every cell was sealed. By this the bee-keeper did his utmost to jeopardise his harvest; but as honey was readily saleable at that time at a somewhat large sum per pound the loss was not so severely felt as it would be in the present year, when the bee-keeper has to combat low prices by increased production. The loss occasioned by placing a small or even a good sized super on a stock and leaving it there till finished is easily accounted for by the fact that honey must be left unsealed until a sufficient evaporation process has been completed. Every cell in the super being filled and no additional room afforded, the empty cells in the body hive would next be filled, then the cells from which the young bees emerge, until at last the queen is crowded out, the prospect for the year ruined, and the stock itself destroyed.

Again, it is a mistake to place too small a super on any stock. If a stock is ready to work in supers at all it will commence in one of moderate size as soon as in a small confined space, which must rapidly be filled to overcrowding with the eager bees. A super body of ten standard frames, a rack of twenty-one 1-lb. sections, or any divisible super of some 20 lbs. capacity may be used; every bee can then at once commence work, and the bee-keeper will be ready to give increased space when it is required. Many bee-keepers who are decided in their opinion that the tiering system is by far the best and

most profitable under ordinary circumstances, split upon the rock as to whether the second super should be placed above or under the first and partially filled super. With all due deference to the opinion of those who differ from me my experience is that—early in the season and when there is a fair prospect of a continued honey flow—it is to the manifest advantage of the bee-keeper to place the second and following super between the brood nest and the earlier placed super or supers. By so arranging the supers a vacant space is left between the brood nest and the partially filled super, and this space the bees will use every endeavour to fill with comb. But it may be said that by so placing the supers there is a risk that the supers may not be completely filled. This risk may, however, with care be minimised. In my own experience the loss from this cause has been so trifling that it has never in any single year been greater than the loss which would be experienced by a bee-keeper following the method approved by many of placing the second and subsequent supers on the top of the one already in position. But even if in occasional seasons a considerable loss was experienced owing to the incompleteness and imperfect sealing over of the supers, the loss so occasioned will be far more than compensated for by the increased yield of honey in other years.

Another advantage—and to many bee-keepers a considerable one—is gained by placing one super beneath the other; so that the top supers, even if not completed quite so rapidly, are at any rate in less danger of being damaged by the heat of the hive and the constant travel of the bees over the comb. Now at a busy time of the year it is a considerable point gained if a labourer, or farmer, or other person who is engaged in apicultural pursuits—which when the honey flow is at its height demands his attention—is able to delay the removal of his supers without fear of their suffering in quality by being allowed to remain on the hive. In the case of supers of comb required for extracting purposes this argument will not apply, because the purity of the cappings is not material; but a super body may therefore be left on the hive in any position until the whole of the super bodies are ready for removal, and the bee-keeper has time to spare to pass the combs through the extractor, and the quality of the honey will by the delay in the removal of the supers be considerably improved. Whichever system the bee-keeper elects to pursue, he must give sufficient room and not too much. Taking into consideration the strength of his stocks, the flora of the district, the weather, and the prospective length of the honey flow, he must determine whether it will be to his advantage to place a third, fourth, or fifth tin upon his stocks, or whether by doing so he will endanger his chance of setting his earlier placed super completely sealed and finished. These are points which the discretion of the individual can alone decide. No hard-and-fast line can be drawn, but most bee-keepers can easily determine the amount of super space which the bees will probably require. Supers, especially early in the season, can hardly be kept too warm. During the cold nights of early summer many supers are entirely deserted by the bees, simply because sufficient care has not been taken to wrap the super up warmly in suitable coverings. As the season advances and the heat increases in intensity the coverings may gradually be lessened, but great care must be exercised, or the bees will be driven from their work. If possible the covering should be lighter during the heat of the day and heavier at night. Too high a temperature will give the bees an inclination to swarm, too low a temperature will drive them from the

super to the brood nest. The yield of honey is greatly increased by the use of empty combs in supers, but foundation may be used with great success where comb is not available. The thinnest foundation which it is possible to obtain must be used in the sections and the supers, the contents of which are intended for sale as "honey in the comb," while full sheets of ordinary wired foundation are very valuable for use in frames which are intended for extracting purposes. The wires give solidity to the comb, and enable even the newest comb to be passed through the extractor without material damage. Any size of frame may be used in a super body, but it is always convenient to use frames interchangeable with those in use in the body hives.

Each succeeding year will add to the experience of the bee-keeper: each year he will probably find some new contrivances to aid him in his work. These are the fruit of experience. It is impossible to set down on paper a remedy for every misfortune, but a man who has mastered the elements of bee-keeping will be able to discover efficient means of overcoming most of his difficulties, and will perhaps add something to the knowledge possessed by bee-keepers of more experience than himself. A modest self-confidence engendered by knowledge will go far towards making a success, and a determination to succeed will, backed up by such self-confidence, generally ensure success.

Bee-keepers as a class are ever ready to assist their neighbours; what knowledge they possess, that they are willing to impart to others. There are no "tricks of the trade," yet every man of any experience in the management of bees will have certain little contrivances of his own to meet certain difficulties, and will gladly assist a brother bee-keeper to the utmost of his ability. Even if it were not impossible to write down these small helps sprung from unexpected difficulties, it would perhaps be an injury rather than an assistance to the bee-keeper to do so, because by taking away scope for ingenuity it would naturally diminish the interest which difficulty almost invariably creates.—FELIX.

#### PLACING BEES AT THE HEATHER—THE DISTANCE THEY WILL FLY.

IN the issue for October 20th I intimated that in another letter I would explain the reason I prefer placing bees a mile from the Heather rather than on it; and as I see your valued correspondent ("A Lanarkshire Bee-keeper") for November 3rd rather questions my wisdom, I think I cannot do better than explain the matter at once, so that he and all others may understand the matter.

My locality is about five miles due east of the moors, which are comparatively level table lands, 1200 or 1400 feet above sea level; they are here about four miles wide, and extend from Derbyshire, through Yorkshire, into Scotland. They vary in width in several places, and there are also several elevations rising to great heights, yet, generally speaking, they are level. On both sides here, west and east, the land is in a high state of cultivation up to its edge, and to look at the fine crops of Potatoes on the same level as the barren moors one would think they might be cultivated also, and so they might if shelter could be provided to break the wind. The Sheffield railway stations, the Town Hall, and the markets, where land sells at auction for £25 per yard, are within five miles of the Heather; in fact the borough boundary on its west side crosses a part of the moors. Thus it will be seen we have no lowland Heather. I make this explanation so that others may be able to compare their locality with mine.

Heather honey is the most peculiar; it is thinner when first gathered, and is thicker when ripe. When it is abundant bees have not to fly from blossom to blossom like they do on white Clover, but they only have to creep from one or two stems close together, and without tiring themselves they are soon loaded up. How long it takes them on an average to load up I cannot say exactly, but in 1886 I placed some black bees (I had driven the day before twenty miles away) about one mile off the Heather. I opened the entrance at twelve o'clock at noon (I had hived them), and at 12.30 P.M. they were returning from the moors laden with Heather honey, having "marked the locality" gone to the moors, loaded up, and returned in thirty minutes. There were about twenty-six strong

stocks close by working to the moors which may have guided them somewhat, but still we may safely venture to conclude a bee will make three journeys per hour at a mile distance.

When the bees bring in the thin honey they deposit it in every empty cell they can find, and when night comes they at once regorge themselves with it, and by putting forth as much energy as possible "sweat" out the superfluous moisture, after which they deposit it in store combs. The enormous heat they create for this purpose sometimes induces half of the bees inside the hive to come out, all of which will be in the greatest agitation, and the noise they make can be heard a long way off. This theory about bees reswallowing their honey and ripening it at night was ably put forward by the late Mr. Pettigrew. It has been considered by some, who claim to be authorities, a crazy idea, but it is received by me as an absolute fact, and did I believe otherwise I should have to close my eyes against a lot of evidence proving its truth.

Bees very soon fill all their cells even in a large hive, and they are compelled by necessity to ripen their stock, and so reduce its compass before they can gather more. Now, if they are a distance from the moors, in flying home they ripen it considerably while on the wing, or, in other words, they are obliged to ripen it through the expenditure of energy; therefore, why not let them use some of this energy that has to be expended in travelling a certain distance to and from the moors? Bees so placed will not show such a large bag of bees outside, and there will be quite as much honey stored inside. So much does flying home ripen honey, that when bees have five miles to fly it is, to all intents and purposes, already ripe when they reach their hives. "A. L. B. K." admits that he has seen stocks placed three miles further away from the pasture store as much Heather honey as those close to it in good seasons, but considers that in bad ones those placed in the midst of Heather would do much better, and implies that he has seen stocks starving three miles away, while such stocks have been gathering honey, yet he advances no evidence that the bees placed in the midst of Heather had not three or four miles to fly before reaching honey-yielding blossoms, but yet he does admit that he has seen his bees working two and three miles from their hives at 1000 feet higher elevation, having neglected that close to. Mr. Raitt and the late Mr. Pettigrew have affirmed that Heather at a low elevation yields little or no honey, and I have often noticed bees working uphill on Clover two miles away, yet not a bee could be found a quarter of a mile off below their hives.

I am quite willing to admit that it is best to place bees as near their pasture as possible for all sources of supply except Heather, and to explain the matter I think I cannot do better than give my evidence, which is the basis of my belief. In 1884 I, and a number of others, took our bees to the moors. We placed them in a garden close to the moors, and within the Sheffield Borough boundary, over the garden wall. The Heather lay in an unbroken line as far as the eye could see. At first the season was fine, honey was stored in quantities, then came a changeable period; in fact, it was just such weather as "A. L. B. K." would expect bees close to the moors to outstrip those at a distance. I saw my stocks dwindle, and also my companions, and though I thought they had gone down much, I did not feel surprised till I began overhauling my neighbours' bees that stood between one and five miles from the Heather. At one to three miles distance I could not see any less honey, yet the bees were four or five times as numerous. I at once concluded the stocks had been stronger, and so accounted for the large amount of honey, yet I thought it rather curious all should have more bees. In 1885 I particularly noticed these people's stocks before the Heather bloomed. Again I and my companions took our bees to the same place. The season proved as bad as it could be; day after day it was either dull, windy, or wet, sometimes all three. There were only three days on which bees really worked, yet they turned out wet towards the afternoon, I could find thousands of bees chilled on the Heather. Being close to they could smell it, and attempted to work, but getting chilled and wet they never rose again. Everyone who had bees there found they had dwindled down to nuclei, but in examining those a mile or more away I found quite as much Heather honey, and the hives crowded full of bees, and where short of stores they were soon fed, and all came out well in the spring; while of all those that stood on the Heather not 10 per cent. lived, and they were practically worthless for profit. I at once saw how it was—viz, when the weather is fine they work as well a mile or two away as close to. When it is bad they stay at home, as instinct teaches them that they cannot make the journey in safety, while those close to are tempted to work to their death when it does come a fine day; those at a distance can, therefore, send out more workers. Thus in indifferent weathers stock standing one to three miles off will store more honey and have more mature bees to go into winter quarters. It is these mature bees we want for wintering, and not young ones hatched in October, as our friend very well knows.

I have several times noticed "A Lanarkshire Bee-keeper" assert that working on the Heather seems to wear bees to death more than any other honey-yielding blossom. It seems to be well understood by those who are in the habit of taking their bees to the Heather, and he has also several times asserted that no satisfactory explanation has been given. If he will carefully ponder over these lines I think he will now comprehend the cause.

After 1885 I did not require further experience to realise the situation. I told my companions what I thought of the matter, and that in future I should place them not less than a mile away, and let the bees also have 600 feet rise to reach the Heather. They have been in one place in 1886 and 1887, and though this year the stocks lost many of their

foraging bees through returning to their old apiary five miles away, as I have explained, yet they gathered as much honey as those placed on the Heather, and the hives were also quite full of bees, while those put on the Heather were not a third of the strength. I do not think another season I shall be able to compare with any bees in this district that have been placed close on the Heather, as most now seem satisfied I am correct in my theory. Place bees a safe distance away, and the Heather harvest puts them in the best heart for winter; plenty of stores and plenty of mature bees. As to the Heather having a weakening influence, why I took mere nuclei this year, and brought them back rousing stocks, and had to give them more combs to prevent overcrowding.

In addition to the advantages I have here depicted, let us consider the following. The moors are not inhabited except by a few gamekeepers and a shepherd or two, in whose care (!) bees are placed. You have to arrange your own accommodation the best you can. If there happens to be a wall or ledge of rock to act as a wind break you are in "clover," but as a rule you have only the hollows in the wild moorland for shelter. You place your bees yourself; do all the work yourself; and when you go to fetch them home, you have 1s. per hive to pay for all that are alive, those that die are not charged for. These are the terms charged and enforced by all who take in bees in this district. This rent and expenses in a bad season like 1885 is well calculated to check moving bees to the Heather. Then the roads are bad; if the rutty tracks can really be called roads. The journey every time you want to look at them is a great trial, while a mile or so away you will find a village, a good road to it, if not a railway station close to, as in my case, and for 2s. 6d. you can have the use of a garden, a field, or an allotment on which you could place 100 or more hives, and you can command good help and accommodation when required. These are important matters to a cottager who desires to make his bees pay.

In moving bees to and fro, I spread cheese cloth over frames which are broad shouldered; two strong strips of wood screwed over their ends keeps them in place, and yet allows combs to have a certain amount of elasticity, which is important. The hives are loaded on spring drays, in such a way that the combs are at right angles with the axle—that is, in a line with the dray; some people say they should be placed the other way about, but no one will catch me doing it. The dray requires loading so that the springs show signs of "giving;" they will then respond to every variation in the road: loading so and travelling at dark, you can go at either a walk, a trot or a gallop, even when combs are sealed to the bottom. I have never yet had a comb break down in transit, and my frames are 14 inches wide by 10 $\frac{3}{4}$  deep, and mostly weigh from 4 to 5 lbs. when returning from the Heather. If I have not made this important subject clear enough, I shall be happy to do so in reply to questions for more information on any point.

Perhaps it is not generally known that when the wind is light and the sky cloudless, during the daytime it is very hot on the moors, particularly in August, but at night and in bad weather during September it is very cold and wretched, so that it is certain death for a bee to turn out. At 600 feet lower elevation it is warmer, more sheltered, and they are able to return.—A HALLAMSHIRE BEE-KEEPER.

#### TRADE CATALOGUES RECEIVED.

Davis & Jones, Lilford Road, Camberwell, London, S.E.—*Descriptive Catalogue of New and Old Chrysanthemums, 1887-1888.*



All correspondence should be directed either to "THE EDITOR" or to "THE PUBLISHER." Letters addressed to Dr. Hogg or members of the staff often remain unopened unavoidably. We request that no one will write privately to any of our correspondents, as doing so subjects them to unjustifiable trouble and expense.

Correspondents should not mix up on the same sheet questions relating to Gardening and those on Bee subjects, and should never send more than two or three questions at once. All articles intended for insertion should be written on one side of the paper only. We cannot reply to questions through the post, and we do not undertake to return rejected communications.

**Books (B. M. D.).**—The book by Mr. W. Low is published by Chapman and Hall, London; or you could obtain particulars from the author, Euston Hall Gardens, The for 1.

**Primula erosa (J. T. S.).**—Your card has been forwarded to our correspondent, who is, like yourself, an amateur.

**Size of Double Tennis Lawn (J. L.).**—To allow space and to look well the lawn should be 40 yards long and 30 yards wide, any extra length and width being decidedly advantageous.

**Flowering Plants for North Wall (Idem).**—*Berberis stenophylla*, *Cornilla Em-rus*, *Crataegus Lelandi* (for its berries), *Cydonia japonica* var. *princeps*, *Forsythia suspensa*, *Jasminum nudiflorum*, and *Roses*.

**Chrysanthemum (J. B. H.).**—We have several times seen the Queen of England *Chrysanthemum* exhibited as light in colour as the bloom you have sent, and we do not think it sufficiently distinct to be invested with a varietal name.

**Eucharises (T. H.).**—We cannot find any mites on the bulbs sent, but dense fog and gaslight that have been general in London for some days are not the most favourable conditions for examining small objects. The roots appear unhealthy. You cannot err by soaking the bulbs in a strong solution of soft soap, with a wine-glassful of petroleum added, before potting them, though we are by no means certain they are attacked by the mite.

**Vines and Plants (Puzzled).**—In the advice to which you refer plants were not considered. Your Vines will rest in a temperature of 45° and that will suffice for Primulas. A night temperature of 50° is needlessly high under the circumstances, but the day temperature from sun may be higher without injury, the house being kept dry. A moist atmosphere is not required by the plants, but they must not suffer through drought at the roots, nor yet be watered excessively. With thoughtful attention you ought to succeed in your object.

**Planting Paeonies (B. K. D.).**—A position much shaded by trees is not a good one for the plants; but if not under the drip of the trees, and the ground is not impoverished by their roots, they would succeed fairly well. The bed should be well manured and deeply stirred. Good sorts are *Albiflora chinensis plena*, white; *Albiflora Whitley*, white; *Atrosanguinea*, crimson; *Decandolle*, purplish rose; *Henry Demay*, violet-purple; *Eten-dari du Grand Homme*, rosy purple; *Marie Lemoine*, rosy blush; *centre creamy white*; *Madame Bollet*, pink tipped white; *Splendida*, rose; *Madame Channay*, deep rose; *Souvenir d'Auguste Meillez*, crimson-purple; and *Doyen d'Enghien*, light carmine, tipped white. They may be planted when the weather is mild.

**Storing Fruit (K. S. A.).**—The top of the house and very light is the worst possible place for storing Apples and Pears. Light is prejudicial to the keeping of fruit. A dark cellar is in every respect preferable, as it insures uniformity of temperature, and a moderate degree of moisture is not injurious, as it keeps the fruit plump. The fruit takes no harm laid on beech or other non-resinous wood shelves; or if the shelves are deal a thin layer of clean dry straw will form a good bed, and prevent any taint arising from the wood. It is best to place the fruit in single layer, especially the choicer sorts, and there is no necessity to "turn it." The fruit should, however, be occasionally examined for the removal of any decayed, handling them carefully. Commoner sorts of fruit may be placed in layers or several deep, care being taken to remove any that show symptoms of decay.

**Composition to Prevent Rabbits Eating Shrubs (Idem).**—There are some compositions that have a more or less deterrent effect on rabbits eating shrubs. One of the best is fish oil, which may be had at most fishing stations, but its smell is very nauseous. There are few shrubs that rabbits will not eat, especially in severe weather. The best remedy is to exclude them by wire netting. For shrubs that rabbits do not care much about see the issue of November 10th.

**Boiler and Piping for Heating House (E. B.).**—To maintain a temperature of 50° by artificial means in ordinary weather two rows of 4-inch pipes along the front would be sufficient, having them one over the other—i. e., a flow and return; but to maintain that temperature when the weather is very severe you would require at least another row of piping, or two flows and a return. If you do not mind the expense it would be best to have four rows of 3-inch piping, two flows with corresponding returns, which would prevent the necessity of heating them highly to maintain the proper temperature. A saddle boiler, 18 inches long, 10 inches wide inside, and 11 inches high, would heat the pipes. Perhaps you would prefer an improved form of boiler; but we never recommend any particular make of boiler for reasons that will be obvious on reflection.

**Dressing for Vine Borders (J. S.).**—With the roots deep a top-dressing is not of much consequence, as they are not readily attracted upwards. By all means put the drainage right, then remove the surface soil down to the roots; and lift some of them, laying them in fresh material. If this be impracticable without prejudicing the crop much may be effected by removing the soil amongst the roots at the collar, and replacing with fresh, so as to encourage fresh roots, which may, by judicious surface dressings, be induced to spread over the surface or upper part of the border. If you leave the border otherwise as it is, apply a dressing of lime an inch thick, and mix it with the soil as deeply as can be done without disturbing the roots, or very little, and it may be repeated in spring, but only then, pointing it in. Good loam with a twentieth of half-inch bones is a good surface-dressing 2 or 3 inches thick, mulching during growth.

**Stands for Exhibition Blooms, Chrysanthemums (A Would-be Exhibitor).**—Mr. Molyneux sends the following reply:—"You need not meet troubles half way regarding the sizes of boards whereon to show blooms, because it is not likely that you will have many blooms of the size quoted—9 inches. Blooms of that size are rare. Where they do occur, and the stands are not allowed to be larger than 2 feet by 1 foot 6 inches wide, then one bloom must overlap another. This will not make any material difference to the exhibitor's chance of success, because good judges do not pass such flowers without notice. It is seldom that the front row blooms on any stand are so large that they cannot be set up on the orthodox stands; therefore if larger stands were used to accommodate the few extra large blooms the front and middle rows would suffer by having too much space. The National Society admits the use of larger boards for Japanese varieties, but they are seldom used. Exhibitors are alive to the fact that if larger boards be employed many of the blooms will not nearly touch each other



and in consequence they do not appear to be so large. Then, again, the inconvenience of carrying the stands to and from the shows is increased considerably, and it is the best plan to have all of one size. Even if some of the largest blooms do overhang the sides of the stands so much the better; all that is required is simply placing them in the centre of the stand for convenience of transit, replacing them again when the show is reached."

**Renovating Pear Trees (A Young Hand).**—It is satisfactory to know that our advice has been useful to you. When trees get into bad condition there is something wrong in the management, or the roots are unfavourably located. It seems the trees operated upon were in both cases had, therefore root-pruning, lifting the roots and laying them in fresh and good soil nearer the surface, together with cutting away dead spurs and shortening those elongated, also cleansing them with an insecticide, resulted in improvement. We consider you have acted wisely, the results showing the operations to have been performed with care and judgment. The Pears (No. 1, Gansel's Bergamot; 2, Ne Plus Meuris; and 3, Josephine de Malines) are fairly good fruit, the others inferior; but the trees will probably improve under intelligent treatment, and bear much better fruit.

**Vines Unsatisfactory (Idem).**—The best plan will be to lift the inside roots first, as they will in all probability be less plentiful than those in the outside border, being careful to retain all the small roots or fibres emanating from the collar, laying them in fresh material with a view to induce fresh rootlets, encouraging them to extend through the border near the surface by mulching during growth, for keeping the border moist. By doing the inside border this season the Vines will have recovered sufficiently another season to admit of the outside border being similarly treated. With care the crop will not be jeopardised but improved by the renovation of the border. The old soil being good, you may use half for mixing with the sods or fresh turf with half the quantity of the old soil of fresh horse droppings. Give preference to the ameliorated surface soil of the border for incorporating with the fresh materials. Add a tenth part the above of old mortar rubbish, a similar quantity of charcoal, and a twentieth each of bones and wood ashes. They should all be well incorporated. If you use a larger proportion of the old soil, add to it a sixth part of freshly slaked lime. It is difficult to advise about the varieties, but there is no course so safe as following that affording the most satisfactory results. All the Vines you name form good stocks, excepting the White Frontignan, therefore you may proceed upon the lines most likely to meet the acceptance of your employer. The Grapes named could not well be improved upon for a vineyard requiring a good heat. Alnwick Seedling would be more suitable than White Frontignan. Mrs. Pince should be artificially impregnated, and it then does well, having quality in advance of late Grapes generally. One thing is noteworthy—that of the eight sorts named Alicante is the only one that does well, which is a confirmation of our experience of this much-maligned Grape—viz., that it succeeds under circumstances that others do not, being good, particularly in a strong soil, when such as Mrs. Pince and Lady Downe's are indifferent, though they are both superior when well grown.

**Names of Fruits.**—The names and addresses of senders of fruit to be named must in all cases be enclosed with the specimens, whether letters referring to the fruit are sent by post or not. The names are not necessarily required for publication, initials sufficing for that. Only six specimens can be named at once, and any beyond that number cannot be preserved. (F. Goodwin).—1, Scarlet Nonpareil; 2, Dumelow's Seedling; 3, Margil; 4, Royal Russet; 5, Court Pendu Plat; 6, Hacon's Incomparable. A very pretty lot of fruit, all typical specimens. (J. Moreby).—1, Rhode Island Greening; 2, Gravenstein; 3, Northern Greening; 4, Striped Holland Pippin; 5, Cox's Orange Pippin; 6, Wyken Pippin. (E. Fisher).—1, Beurré Diel; 2, Royal Wilding; 3, Some cider Apple, probably never had a name; 4, Blenheim Pippin; 5, Not known, probably another cider fruit; 6, Wyken Pippin. (J. J.).—1 and 2, Beurré Diel; 3, Beurré Hardy; 4, Easter Beurré.

**Names of Plants.**—We only undertake to name species of plants, not varieties that have originated from seed and termed florists' flowers. Flowering specimens are necessary of flowering plants, and Fern fronds should bear spores. Specimens should arrive in a fresh state in firm boxes. Slightly damp moss or soft green leaves form the best packing, dry cotton wool the worst. Not more than six specimens can be named at once. (T. S. W.).—1, Odontoglossum Rossi majus; 2, Laelia autumnalis; 3, L. autumnalis atro-rubens.

**COVENT GARDEN MARKET.—NOVEMBER 23RD.**

TRADE still continues depressed, and with heavy supplies prices remain low.

**OUT FLOWERS.**

	s. d.	s. d.		s. d.	s. d.
Abutilons, 12 bunches ..	3	0	to	6	0
Anemones, 12 bunches ..	0	0	0	0	0
Arum Lilies, 12 bunches ..	5	0	8	0	0
Asters, 12 bunches ..	2	0	6	0	0
" French, bunch ..	0	0	0	0	0
Bouvardias, bunch ..	0	6	1	0	0
Camellias, blooms ..	2	0	4	0	0
Carnations, 12 blooms ..	1	0	2	0	0
" 12 bunches ..	0	0	0	0	0
Chrysanthemums, 12 bchs. ..	6	0	12	0	0
" 12 blooms ..	0	6	3	0	0
Cornflower, 12 bunches ..	0	0	0	0	0
Dahlia, 12 bunches ..	0	0	0	0	0
Daisies, 12 bunches ..	2	0	4	0	0
Eucharis, dozen ..	4	0	6	0	0
Gardenias, 12 blooms ..	2	0	5	0	0
Gladiolus, 12 sprays ..	0	0	0	0	0
Hyacinths, Roman, 12 ..					
" sprays ..	0	6	1	6	0
Iris, 12 bunches ..	0	0	0	0	0
Lspageria, white, 12 ..					
" blooms ..	1	6	3	0	0
Lspageria, coloured, 12 ..					
" blooms ..	1	0	1	6	0
Lilium longiflorum, 12 ..					
" blooms ..	6	0	9	0	0
Lilium lancifolium, 12 ..					
" blooms ..	0	0	0	0	0
Lilies, White, 12 bunches ..	s. d.	s. d.			
" Orange, 12 bunches ..	0	0	to	0	0
" Marguerites, 12 bunches ..	2	0	6	0	0
" Mignonette, 12 bunches ..	1	0	3	0	0
" Myosotis, 12 bunches ..	0	0	0	0	0
" Narciss, 12 bunches ..	0	0	0	0	0
" White, English, bch. ..	0	0	0	0	0
" Pansies, 12 bunches ..	0	0	0	0	0
" Peas, Sweet, 12 bunches ..	0	0	0	0	0
" Pelargoniums, 12 trusses ..	0	9	1	0	0
" scarlet, 12 trusses ..	0	4	0	9	0
" Poinsettia, 12 blooms ..	0	0	0	0	0
" Primula (single), bunch ..	0	0	0	0	0
" (double), bunch ..	0	9	1	0	0
" Polyanthus, 12 bunches ..	0	0	0	0	0
" Ranunculus, 12 bunches ..	0	0	0	0	0
" Roses, 12 bunches ..	0	0	0	0	0
" (Indoor), dozen ..	1	0	1	6	0
" Tea, dozen ..	1	6	3	0	0
" red, dozen (French) ..	1	0	2	0	0
" yellow ..	0	9	1	6	0
" Stephanotis, 12 sprays ..	4	0	6	0	0
" Tropaeolum, 12 bunches ..	0	0	0	0	0
" Tuberoses, 12 blooms ..	0	6	1	0	0
" Tulips, dozen blooms ..	0	0	0	0	0
" Violets, 12 bunches ..	1	0	1	6	0
" (French), bunch ..	1	6	2	0	0
" (Parme), bunch ..	2	0	4	0	0

**PLANTS IN POTS.**

	s. d.	s. d.		s. d.	s. d.
Aralia Sieboldi, dozen ..	6	0	to	12	0
Arhorvitæ (golden), dozen ..	6	0	9	0	0
" (common), dozen ..	0	0	0	0	0
Asters, dozen pots ..	0	0	0	0	0
Azalea, dozen ..	0	0	0	0	0
Begonias, dozen ..	4	0	9	0	0
Capsicums, dozen ..	0	0	0	0	0
Chrysanthemums, dozen ..	4	0	12	0	0
Cineraria, dozen ..	0	0	0	0	0
Dracæna terminalis, doz. ..	30	0	60	0	0
" viridis, dozen ..	12	0	24	0	0
Erica, various, dozen ..	9	0	18	0	0
Eunymus, in var., dozen ..	6	0	18	0	0
Evergreen, in var., dozen ..	6	0	24	0	0
Ferns, in variety, dozen ..	4	0	18	0	0
Ficus elastica, each ..	1	6	7	0	0
Foliage Plants, var., each ..	2	0	10	0	0
Fuchsia, dozen ..	6	0	to	9	0
Geranium (Ivy), dozen ..	0	0	0	0	0
" Tricolor, dozen ..	0	0	0	0	0
Hydrangea, dozen ..	0	0	0	0	0
Lilies Valley, dozen ..	0	0	0	0	0
Lilium lancifolium, doz. ..	0	0	0	0	0
" longiflorum, doz. ..	0	0	0	0	0
Marguerite Daisy, dozen ..	6	0	12	0	0
Mignonette, dozen ..	3	0	6	0	0
Musk, dozen ..	0	0	0	0	0
Myrtles, dozen ..	6	0	12	0	0
Palms, in var., each ..	2	6	21	0	0
Pelargoniums, dozen ..	0	0	0	0	0
" scarlet, doz. ..	3	0	9	0	0
Poinsettia, dozen ..	12	0	15	0	0
Solanum, dozen ..	9	0	12	0	0
Spiræa, dozen ..	0	0	0	0	0

**VEGETABLES.**

	s. d.	s. d.		s. d.	s. d.
Artichokes, dozen ..	1	0	to	2	0
Asparagus, bundle ..	0	0	0	0	0
Beans, Kidney, per lb. ..	0	3	0	0	0
Beet, Red, dozen ..	1	0	2	0	0
Broccoli, bundle ..	0	0	0	0	0
Brussels Sprouts, ½ sieve ..	3	6	4	0	0
Cabbage, dozen ..	1	6	0	0	0
Capsicums, per 100 ..	1	6	2	0	0
Carrots, bunch ..	0	4	0	0	0
Cauliflowers, dozen ..	3	0	4	0	0
Celery, bundle ..	1	6	2	0	0
Coleworts, doz. bunches ..	2	0	4	0	0
Cucumbers, each ..	0	4	0	6	0
Endive, dozen ..	1	0	2	0	0
Herns, bunch ..	0	2	0	0	0
Leeks, bunch ..	0	3	0	4	0
Lettuce, dozen ..	0	9	to	0	6
Mushrooms, punnet ..	0	6	1	0	0
Mustard and Cress, punt. ..	0	2	0	6	0
Onions, bunch ..	0	3	0	0	0
Parsley, dozen bunches ..	2	0	3	0	0
Parsnips, dozen ..	1	0	0	0	0
Potatoes, per cwt. ..	4	0	5	0	0
" Kidney, per cwt. ..	4	0	0	0	0
Rhubarb, bundle ..	0	2	0	0	0
Salsify, bundle ..	1	0	1	6	0
Scorzouera, bundle ..	1	6	0	0	0
Seakale, basket ..	0	0	0	0	0
Shallots, per lb. ..	0	3	0	0	0
Spinach, bushel ..	1	6	2	0	0
Tomatoes, per lb. ..	0	4	0	6	0
Turnips, bunch ..	0	4	0	6	0

**FRUIT.**

	s. d.	s. d.		s. d.	s. d.
Apples, ½ sieve ..	1	6	to	3	6
" Nova Scotia and ..	0	0	0	0	0
" Canada barrel ..	0	0	0	0	0
Cherries, ½ sieve ..	0	0	0	0	0
Cobs, 100 lbs. ..	60	0	0	0	0
Figs, dozen ..	0	0	0	0	0
Grapes, per lb. ..	0	6	2	6	0
Lemons, case ..	10	0	15	0	0
Melon, each ..	0	6	1	0	0
Oranges, per 100 ..	6	0	to	12	0
Peaches, dozen ..	2	0	6	0	0
Pears, dozen ..	1	0	1	6	0
Pine Apples, English, ..					
" per lb. ..	1	6	2	0	0
Plums, ½ sieve ..	0	0	0	0	0
St. Michael Pines, each ..	3	0	5	0	0
Strawberries, per lb. ..	0	0	0	0	0



**PROGRESS.**

A FEW hours before sitting down to write this article we received our copy of the second part of the Journal of the Royal Agricultural Society of England for the current year, and a cursory glance through its pages showed us that they contain much useful and interesting information. Among other subjects which mark the progress of farmers, that of Agricultural Education attracted our especial attention as of primary importance in regard to its influence upon the future of farming in this country, and we purpose now giving our views of the training of young men in agriculture, with a brief review of the questions enumerated for the examination of candidates for the Society's certificates.

The questions embrace Practical Agriculture; Agricultural and General Chemistry; Mensuration and Land Surveying; Mechanics and Natural Philosophy; Book-keeping; Geology; Botany; Anatomy and Animal Physiology. Taking them in the order of enumeration, we find more questions in Practical Agriculture than in any other section, and yet we are not satisfied, and would fain see them embrace many more branches of the daily routine of farming. Question 1, as to the amount of capital required for a farm, mixed husbandry, of 500 acres of strong land, admits of various answers. For our own part, we would rather have £20 than the proverbial £10 per acre to invest in such a farm now,

for sure are we that there never was more urgent reason for high farming tempered by sound experience and common sense than now. High farming and extravagance are, we know, in the opinion of many worthy persons synonymous terms, but to this erroneous conclusion we are bound to take exception. High farming is, in our conception of the term, an embodiment of sound practice, true economy, energetic action, watchfulness, and ability to adapt our practice to the growth of produce suitable for markets available to us for the profitable disposal of it. Well indeed will it be for students if they grasp this idea clearly at the outset as a fundamental rule or axiom that nothing can alter.

We do not purpose taking the whole of the questions categorically; many of them are what may be termed examiners' questions, while others are highly important, as for example—"Explain the changes which may take place in the constituent parts of soils as the result of 'paring and burning.'" On what kinds of soil and under what circumstances is the operation conducted with benefit, and when would it be disadvantageous?" or "What feeding materials in common use are specially useful on account of the oil they contain; which for the nitrogenous constituents, which for starch, which for sugar? Give the per-centage amount of the selected ingredients generally found in the foods named."

This, we may note in passing, is a question which it would be well if all farmers could understand and answer. Repeatedly have we pointed out that when two sacks of Oats can be purchased for one of Barley, it is clearly in the farmer's interest that he should sell the Barley and purchase the Oats for feeding purposes on the farm. The per-centage of fat and flesh-formers in Oats is 75, in Barley it is 82. We feed animals by measure and not by weight, and we know positively from many years' experience that Oats, either whole or crushed or ground into fine meal, are most nutritious food for all farm animals. We have wandered slightly from the subject of our theme, but the fact that one of the students' questions induced us to do so is clear proof of its value. Well, we agree by all means that young men should be well grounded in many if not most of the subjects given in the examination papers. This done, we would have them enter forthwith upon practice. A suggestion that we should take pupils induced us to consider what they would have to acquire to be useful assistants to us, and good men of business upon a large estate. Now that land agents have so many farms in hand they must be good farmers, keen shrewd men of business, ready to adapt themselves to circumstances, and to farm according to local or market requirements. They must not be merely men of line and rule, but their practice must be subject to seasons. They must be prompt to seize opportunities to render their business really profitable, to spend freely when it can be done advantageously, to abstain from any expenditure that does not lead to profit. They must be able correspondents and accountants, good draughtsmen, able to design and alter buildings, to prepare plans, drawings, estimates, and specifications. They must also acquire a thorough knowledge of farm animals, of the work of selection, of cross-breeding, and general management, all which demands steady application, intelligence, good sense, and above all mature experience, which last can only be had at the cost of several years' devotion to the work. Such devotion is, however, given ungrudgingly by all earnest men, for with them the acquisition of knowledge and fondness for their work invariably go together.

(To be continued).

WORK ON THE HOME FARM.

The condition of both our ewe flocks is now satisfactory; the tups are withdrawn, and the ewes will have special attention as to diet and general care. The flock on the home farm is now in the park where there is an abundant supply of acorns, of which the sheep are very fond, and upon which they thrive and fatten; for the present therefore they will require no extra food. The other ewe flock has plenty of grass, and as there are no acorns upon the farm some chaff and Oats will now be given them regularly till the lambing time, which begins by the middle of January. No folding upon Turnips will be done till after the lambing, and we are resolved that, let the weather be what it may, there shall be no Turnips used for pregnant ewes. Our losses have been so heavy owing to the pig-headed obstinacy of our shepherds in this matter, that most stringent orders have been given to both shepherds and bailiffs against the use of Turnips before the lambing. We have plenty of grass for grazing, and if it becomes covered by snow, then in addition to trough feeding with chaffed hay and straw and some corn, we have plenty of hay, Pea and Oat straw for feeding in racks. We may usefully repeat now the important fact that if a pregnant ewe is allowed to gorge itself with a mass of cold watery food such as it finds in half-frozen Swedes or white Turnips, the temperature of its body is lowered so seriously that the effect is fatal to the lamb, leading either to abortion or death in the uterus. We may be told that pregnant sheep have eaten Turnips with impunity; we admit that this is so, but there is so much risk in the matter—risk very much in proportion to the age of the ewe—that we know it is better avoided altogether.

A tenant farmer who had to sell his lambs to obtain funds for Michaelmas payments complained to us that he only had 26s. apiece for them. But we much question if he had just cause of complaint. The lambs were decidedly inferior animals, which were probably not worth more than 12s. or 14s. apiece last June, when we sold our best lambs for nearly 30s. apiece. Had we kept those lambs till the present time they would have been prime fat hoggets worth the top market price, for a man to obtain which so early in the season he must have well-bred animals that have had the best nourishment from the first.

SPRATTS PATENT.—"The Australian Mail just to hand gives particulars of the awards at the Adelaide International Exhibition, by which we see that Spratts Patent, Limited, have obtained the premier position, receiving the highest award. The Saltaire Exhibition just closed have also awarded this Company a gold medal for their unique exhibits of dog, poultry, and game houses and appliances."

OUR LETTER BOX.

'Breaking Up an Old Lea (A. D.).—If there is no more useful herbage for grazing upon your old lea or lay, of eight to ten years, by a 1 means plough at once. Plough deeply, so as to quite turn the soil over, then leave it alone, and sow Black Tartar or White Canadian Oats in February or March, whenever the soil is sufficiently dry for the work. By ploughing now you ensure that it shall be well pulverised by frost during winter, and be ready for sowing early next year. By no means disturb the soil after ploughing at this season of the year, for if you ploughed twice or used a cultivator you would only bring the grass to the surface again, and no amount of harrowing would cleanse the land of it during winter. Rather bury the plant, as we suggest, by a single ploughing, and it will decay and afford some nutriment for the Oat crop. A hundredweight of nitrate of soda per acre would help the Oat crop; but if you wish to give it a full dressing of manure, then give per acre 1 cwt. nitrate of soda, 1 cwt. stamed bone flour, half cwt. mineral superphosphate, quarter cwt. muriate of potash. Take care to have the manures procured separately from a reliable source, and have them well mixed two or three days before using.

METEOROLOGICAL OBSERVATIONS.

CAMDEN SQUARE, LONDON.

Lat. 51° 32' 40" N.; Long. 0° 8' 0" W.; Altitude, 111 feet.

DATE.	9 A.M.					IN THE DAY.				Rain.
	Baromet. ter at 32° and Sea and Level.	Hygrome- ter.		Direction of Wind.	Temp. of soil at 1 foot.	Shade Tem- perature.		Radiation Temperature		
		Dry.	Wet.			Max.	Min.	In sun.	Oa grass	
1887. November.	Inches.	deg.	deg.		deg.	deg.	deg.	deg.	deg.	Ia.
Sunday .....	30.120	40.8	38.0	F.	45.0	42.2	40.0	47.4	33.8	—
Monday .....	29.684	40.6	38.7	N.E.	44.2	44.9	37.8	68.4	35.8	0.012
Tuesday .....	30.154	33.6	32.6	N.E.	43.2	38.2	31.8	56.8	29.7	—
Wednesday .....	30.406	28.4	28.4	Calm	41.5	30.7	24.3	31.4	18.7	—
Thursday .....	30.35	24.4	24.4	N.	41.3	37.4	22.1	57.8	21.3	—
Friday .....	29.439	34.1	34.4	E.	39.2	34.4	23.6	35.2	21.3	0.252
Saturday .....	29.306	33.8	33.2	Calm	38.8	39.0	29.3	39.8	24.8	0.094
	29.892	33.5	32.6		41.7	38.1	29.8	48.1	24.6	0.332

REMARKS.

13th.—Dull all day.  
 14th.—Fine morning, bright afternoon, clear evening.  
 15th.—Red sunrise; bright till 11 A.M., then cloudy for a couple of hours, with a few flakes of snow; fine and bright after, but with a little fog.  
 16th.—Very cold with dense fog, necessitating gas all day except two periods of about thirty minutes each; at 4 P.M., in the external air, objects first became visible at 20 feet distance.  
 17th.—Fine, bright, and cold, but with frequent slight fog.  
 18th.—Dull, with slight fog early, wet and foggy after, very black from noon to 2 P.M. Impossible to read large type close to a window at 1 P.M.; snow from 2.45 P.M. till evening.  
 19th.—Ground white; dull and foggy all day.  
 A very cold and unpleasant week, almost without bright sunshine and with exceptionally severe fogs. Temperature, 12° below that of the preceding week and 10° below the average, the average maximum for the week being lower than the average minimum for the time of year.—G. J. SYMONS.



## COMING EVENTS

1	TH	
2	F	
3	S	
4	SUN	2ND SUNDAY IN ADVENT.
5	M	
6	TU	
7	W	

## THE ROYAL HORTICULTURAL SOCIETY.

**A**S announced in our columns last week the Council of this Society have decided on a course of action which we feel convinced will meet with warm acceptance from the horticultural community. In the opinion of the vast majority of persons interested in the welfare of the Society the South Kensington connection has continued too long. As we have previously stated, it has been the alliance of the Society with the world of fashion, which it has had to share in feeding, that has crippled its power for promoting its legitimate work, and has thereby alienated those who ought to be its natural supporters—horticulturists of various grades all over the country. For a long time past the location of the Society at South Kensington has been, to employ a mild term, unfortunate, eventually becoming practically unendurable, until at length a decision had to be arrived at to enter into a fresh engagement with the Royal Commissioners of the 1851 Exhibition for a further tenure, or seek a habitation for administrative purposes elsewhere. The latter alternative has been chosen, and we believe has been chosen wisely.

The Royal Horticultural Society has been established, not very firmly at times, at South Kensington for twenty-six years. The meeting at which the decision was arrived that the Society should make the gardens there and continue in possession under certain stipulations was held on June 9th, 1859. At that time the late Prince Consort was in full activity in promoting objects connected with the arts and sciences that he believed to be for the public good; the Court was gay, and rank and fashion gave countenance to the great undertaking. Everything looked bright on the surface, and in 1860 twelve members of the Royal Family joined the Society, and the following year Her Majesty granted permission for it to be styled the Royal Horticultural Society. By the agreement effected the Royal Commissioners as landlords, and the Society as tenant under a thirty-one years lease, were each bound to expend £50,000 in the formation of the gardens. For controlling and regulating the expenditure a committee of six persons were nominated—three by the Commissioners and three by the Society, the chairman being selected by the former, and to have “two votes in case of an equality in voting.” That insidious proviso placed the Society at the mercy of the Commissioners, who naturally desired to increase the value of their property by offering inducements that would make the gardens the rendezvous of the fashionable world, and in one year £3000 was actually expended in music to that end. The policy adopted was totally antagonistic to the objects for

No. 388.—VOL. XV., THIRD SERIES.

which the Society was established, and which are defined in its charter.

It may not be without interest at this juncture to glance at the origin of the Society and a few salient points in its history. It is not uncommon to hear opinions expressed that it was never at such a “low ebb” as at the present time. Human nature is perhaps prone to regard the last calamity the greatest, but far greater difficulties beset the Society in past times than have to be encountered now, and as the greater were surmounted surely there is good hope that the lesser will be removed. Reverting, however, to the Society’s commencement and early career, we find it was originated by John Wedgwood, the first proposition occurring in a letter to Mr. Forsyth, dated June 29th, 1801, and on which the opinion of Sir Joseph Banks was desired by the writer. On March 8th, 1802, Mr. Wedgwood wrote to Mr. Forsyth:—“It is now proposed to form a Society for the sole purpose of encouraging horticulture in all its branches, to form a repository for all the knowledge that can be collected on the subject, and to give a stimulus to the exertions of individuals for its farther improvement.” The Society was founded by resolutions adopted at a meeting held on March 7th, 1804, under Mr. Wedgwood’s presidency, and was incorporated as the Horticultural Society of London on April 17th, 1809, for, as is stated in its charter, “the improvement of horticulture in all its branches, ornamental as well as useful,” though attention, according to Mr. Knight, was to be chiefly confined to the latter. After a more or less satisfactory career, during which the cardinal objects were kept steadily in view, the Society established a small experimental garden at Kensington in the commencement of the year 1818; but this being found too limited and too much within the influence of the London atmosphere, it was determined to seek another site, and the Chiswick garden, then thirty-three acres, was taken on a lease renewable for ever, and the stock removed there early in 1822. That is in brief its early record.

Now let some of its vicissitudes be recalled, and the very fact of their being surmounted ought to point directly to the recovery of prosperity from the present time; and if this does not follow it must be through a lack of administrative power as compared with that which rescued the Society from its previous difficulties. They appear to have commenced soon after the acquisition of Chiswick, which was too great for the resources of the Society; and the incurring of obligations too great to be met has been the rock on which it has been nearly wrecked time after time. In 1830 the *Transactions*, which had been published since 1809, was abandoned, as the Society was found to have been “mismanaged almost to ruin.” That was during Mr. Salisbury’s term as Honorary Secretary. He was succeeded by Mr. Sabine in 1810, who at first improved the Society so markedly that a gold medal was awarded to him in 1816. He appears to eventually have become by the adoption of a pushing policy “not only the Secretary, but the President, Council, and head gardener,” and indulged in lavish expenditure for “increasing the imposing aspect of the Society,” until its debts amounted to upwards of £18,000. Yet there was not a shadow of a suspicion on Mr. Sabine’s honesty. The mistake was that “he did not stop to calculate whether the income of the Society was equal to his determined expenditure; but with a rashness as fatal to a society’s as to an individual’s prosperity he resolved on an expenditure, and trusted to hope for increasing the income up

No. 2044.—VOL. LXXVII., OLD SERIES.



to the outlay." The history of the past teaches wholesome lessons. Previous to the South Kensington connection a venturesome and unsound financial policy led to the sale of its house in Regent Street, also its library, and Chiswick was only saved through an appeal to the public resulting in the substantial sum of £2000. Nor can it be overlooked that the prevailing policy of the greater part of the past twenty-five years has been increasing the "imposing aspect" of the Society in the form of musical attractions or of "big shows," which proved a source of weakness rather than of strength. The position at South Kensington was purchased at a ruinous price, for what do we find? This: within about five years of the connection the Society had expended no less than £73,000 in completing the gardens, and was involved in a debt of £53,000, the whole of its liabilities previous to the undertaking being £4000. It will be seen the present obstacles are as nothing in comparison with others that have been overcome, and as the Society will soon be free from alien entanglements it ought by judicious management to be placed on a satisfactory basis, and carry out usefully the work and objects for which it was established.

The removal of the Society from South Kensington is now only a question of months. The final step has not been decided with unanimity, but has led to some resignations. This is almost inseparable in the abandonment of an old and the commencement of a new policy. Seceders in this case are gentlemen of great ability, and are held in high esteem for their probity. They are doing what they feel to be right. The Society must have financial support, but experience seems to show the futility of "trusting to hope" in its forthcoming in any substantial manner from the inhabitants of South Kensington. Great and costly attractions are essential for securing and retaining local Fellows. When the attractions wane the Fellows withdraw, as was shown at the close of the great popular exhibitions, ending with the Colonial. The once "most beautiful town garden in Europe" is now a wild waste, save a narrow strip, and to incur an outlay of at least £2000 a-year for occupying this in the "hope" of its being recouped by local support would, instead of being advantageous to the Society, be far more likely prove its ruin. Besides, to provide attractions for the multitude is quite foreign to the purpose for which it was instituted.

The time has now arrived for making a complete departure in its administration. Let the objects as defined in the charter be kept in view, and accomplished in the best manner the finances allow; and in our opinion this can be best effected by developing the resources of Chiswick. That is the only safe anchorage of the Society. Let trials be made there, experiments conducted, and observations recorded—these to be published for the benefit of the horticultural public through the channels to which they naturally turn for information. It may appear dignified, and give *éclat* to a Society to publish a journal of its own; but that is a matter of sentiment, and these are not sentimental days. A journal would mean a loss of £200 or more a year to the Society if it were produced. This observation is not founded on supposition, but on fact. The public will not wait for official journals intermittently issued, for the simple reason that stale news is out of fashion; and the useful work that might be done at Chiswick ought not to be left in obscurity. But it cannot be done without means. There is the garden and the man—both as good as can be found. Let them have all the support that is possible consistent with sound finance. Let all ideas of purchasing land and erecting buildings

be abandoned. Take no city house at a necessarily high rent that could only be of real service about once a fortnight; but if meetings are to be held in London, as may be desirable, do what some public and scientific bodies do—hire rooms for the occasion, and only then; thus the husbanding of resources will enable adequate recompense for sterling work, such as the Society ought to do and which the public expect. Efficient service is cheap at almost any cost; inferior workmanship and fanciful luxuries dear at any price. Let the Society be managed on the principles indicated, and it will win the sympathy and receive the support of that large section (and it is the largest) of the horticultural community who "like to see something for their money" without long waiting. But time is a prime essential in the remodelling and for collecting the elements of strength.

## CHRYSANTHEMUMS.

### A REVIEW OF THE PAST SEASON.

THAT the season of Chrysanthemum exhibitions just drawing to a close has been a successful one on the whole cannot be doubted for a moment, not so much perhaps for the advance made in the quality of the flowers staged, as for the increased enthusiasm manifested in the exhibitions throughout the country. That the popularity of the flower, which is not unjustly styled the Autumn Queen, is on the increase, cannot be doubted; we have only to look around and note the various exhibitions which have sprung up even during the present year.

I am inclined to think that some new incurved varieties may be brought to light during another year as the result of this season's tropical summer. I have noticed that an unusual number of petals have been found in all incurved blooms this season, probably the result of extra ripening of the wood. This may then be the means of producing new and varied forms in the section to which we have so few additions—the incurved. The great advance made in public favour of the Japanese section is the almost endless variety and form introduced, whereas in the large-flowered or incurved section, the production of new varieties is a very slow process. I am inclined to think that to obtain an advance in the incurved section in size and form we must have entirely new varieties, because I think all has been obtained from those varieties now in existence. Take, for instance, Princess of Wales, which I regard as the most perfect of all incurved Chrysanthemums. When seen in its proper character—size, colour, and form—I think there is nothing to equal it for quality and chaste appearance, and I have watched this variety under many circumstances as to culture, climate, and other influences, but during the last half a dozen years I have not seen any advance made in this flower. Take again Lord Alcester, which is the best of the Queen family. No alteration can be found to have taken place with this for the better; therefore I say if any advance is to be made in the incurved section it must be by the introduction of new varieties. No flower is nearly so popular with the poorer classes than the Chrysanthemum, either in a wish to cultivate it, or simply to inspect those grown by more favoured cultivators, and at the late Portsmouth Exhibition, where the executive adopt popular prices almost throughout the Show, but more particularly on the evening of the second day, when from six o'clock to nine the low charge of 1d. is made, as many as 8100 people entered, and in a populous town like Portsmouth, where the difficulties of cultivating flowers are so great, it only shows what a hold upon the people the Chrysanthemum has acquired. In spite of the tremendous crush during the time named, it could not be said that a single instance of misbehaviour took place. Of course due precaution was taken by this enterprising society to prevent a block at any one particular place by fixing barriers and stationing policemen at certain points, but this was more for the convenience of the public, that all might have the same chance of inspection, than for any other reason. Many other societies in populous towns would do well to follow the example of the Portsmouth society, they would find it the means of adding to their revenue.

As regards the quality of the flowers produced during the season now drawing to a close, referring first to the incurved section, it cannot be said otherwise than that the results have been disappointing, when we consider the excellent appearance that the plants presented during the months of August and September for instance. It has been my privilege during the present month to see flowers grown in many parts of England, but speaking generally the results have not been up to expectation. The blooms in many in-

stances have been large in diameter, but lacking in those two important points which go to make an incurved flower perfect—depth and finish. There has been a considerable amount of roughness visible. Three reasons may be advanced to account for these defects. First, a cold sunless spring, which prevented that free growth so desirable in the production of plants that will perfect blooms of the highest order of merit. Secondly, the excessively hot summer experienced is the cause of much of the roughness in the petals. This has been the cause of so many cross-centred blooms met with, particularly in the southern counties of England. To present flowers in a perfect manner has been much more difficult to the cultivator living in the south than it has been for his more favoured brethren in northern counties, for the reason the summer weather has not been nearly so trying in the north as in the south. I therefore contend that southern cultivators of Chrysanthemums have been handicapped this season as compared with growers residing in the north. The third reason I advance for defective blooms is that in some instances the plants were seriously affected by the severe frosts which occurred early in the season before the plants were safely under cover. Where they were so caught perfect blooms could not be expected from such plants; in many instances the centre of the bud was quite blackened. The worst placed cultivators were those located in hilly districts where night dews are not experienced during the hot months of July and August, as they are in valleys or low-lying districts. For the simple reason there were few dewy nights in those months the plants stood a double chance of being dried to an extent injurious to their proper development later on in the season.

A few remarks on the varieties may not be out of place here. As a rule varieties of the Queen type have done very well, although somewhat late in development, but the best of this family has undoubtedly been Lord Alcester. It has taken more honours for premier bloom than all the other varieties together. In my opinion no collection is complete without it. Princess of Wales has perhaps been the most disappointing, for I have not seen once a thoroughly representative bloom; evidently this variety has suffered considerably. Jardin des Plantes, the finest of all yellows, too, has been conspicuous by its absence in first class form, while Jeanne d'Arc, Lord Wolseley, and Prince Alfred have been good. Here again the northern growers have an advantage over the south. In a late season like the one now passing the former were able to use the first (and consequently finest) blooms of the three varieties named last; whereas in the case of south country growers the first blooms of those named are generally past, and everyone knows what second blooms of such sorts are. Barbara has done well generally, while Hero of Stoke Newington and Princess Teck have done but moderately well. A useful addition to this section is Mrs. Norman Davis, a pure yellow sport from Princess Teck. A good yellow of this class was much needed. Although those shown at the Aquarium were rough, I think this variety is destined to become a standard variety, when stock can be secured early in the season.

The Japanese varieties have been shown in increasing numbers, generally throughout the quality has left little to be desired. There has been an absence of stale blooms, owing of course to the lateness of the season. The colours have been bright and clear, while the staging of these has shown a marked improvement generally. It is not long since it was a common occurrence to see flowers laid flat upon the boards. In such a manner much of their beauty was lost. A too low position dwarfs the blooms, while one too high renders them thin in appearance, particularly if there is a preponderance of varieties with horizontal florets in the stands. Many new varieties have come up to the expectation formed of them late last season, and are destined to become standard varieties. Take, for instance, Carew Underwood, Mrs. J. Wright, Mr. and Mrs. H. Cannell, Avalanche, Edwin Molyneux, Ralph Brocklebank, and Edouard Audiguier; with such sterling varieties as Madame C. Audiguier, Jeanne Délaux, Thunberg, Triomphe de la rue des Châlets, Meg Merrilies, and Criterion, while a decided improvement has manifested itself in that splendid variety Belle Paule, which owing to some reason or other was presentable in only a very few instances last year. Taking it on the whole, it has been a good season for the popular "Japs," the extreme heat of summer apparently not having exercised any ill effects upon their development. This section being much easier of management than the incurved, for the reason that form or smoothness of the florets is not of nearly so much consequence.

I do not know that there is anything in particular to chronicle relating to the reflexed class. This section does not meet with general approbation, being somewhat stiff in appearance, while there is a want of colour, many being dull in appearance. It is true Cullingfordi is a useful addition, and so is Amy Furze, but as to the classification of this variety there appears to be a difference of opinion. In my opinion flowers of this section have not come up to the standard of excellence seen in preceding seasons. There has

been a want of depth and solidity. Anemone Japanese have advanced still farther in public favour. Their long graceful guard florets lend a charm to them as compared with the prim appearance of their older brethren, the older fashioned show Anemone of which Gluck or George Sand is a type. Fabian de Mediana still stands at the head of this section. This variety has in many instances shown a want of centre, also of colour. Nothing new has appeared in this section that I am aware of. A meritorious addition was made last year to the ordinary Anemone section—Grand d'Alveole, a variety producing large full centred blooms of a pale blush, most pleasing in appearance. Fine examples, except in a very few instances, have not been seen of the other sorts as in some other seasons, therefore it must be admitted that this section has suffered somewhat by the tropical weather experienced. Pompons and Anemone Pompons have shown a decided improvement generally. Fewer moderate stands have been shown, while in many instances those shown have been as near perfection as is possible to get without going beyond the limit of what Pompon varieties should be. Mdle. Elise Dordon has maintained the reputation which it came out with last year for cutting. For vase decoration it is alike a gem as it is for exhibition unrivalled.

Single varieties have not come to the front nearly as much as their merits deserve, owing perhaps to the fact that encouragement has not been offered to them by societies in the shape of prizes. For vase decoration, associated with Fern or other greenery, they have no rivals, so light and graceful are they when well disposed.

Groups of Chrysanthemums have proved, if possible, more than usually attractive, not by their improved excellence, but by the increased numbers. At some exhibitions as many as eleven have been staged in competition for the prizes in one class. Plants grown for the purpose of grouping show full well what an adaptable plant is the Chrysanthemum for a variety of purposes. The method of "cutting down" is much to be preferred where conservatory or exhibition groups are required; but for the production of high class blooms it must not be practised. Specimen plants generally do not show any diminution of numbers, whilst the quality has perhaps not been quite so good as in some seasons past; still, many excellent collections have been staged. Less severe training has been practised with good effect, quality of flowers has been more sought after than mere numbers and size of plants, which is a step in the right direction. "Experientia docet," on page 419, gives some capital notes on "winning and losing prizes." No person so quickly assumes an unpopular position in the exhibition world as a "bad loser." Some men cannot lose peacefully. Such men ought never to enter the lists of competitors, of course assuming justice is done to them. Mistakes do occur, but they are few. During the whole of the present season I have not heard a single murmur of discontent from exhibitors who have been placed other than first, which speaks well for the feeling of the great army of exhibitors. Your correspondent pays a very high compliment to Mr. C. Gibson as to his manly bearing when taking second position, which I can readily endorse, having perhaps a better chance of judging him in this respect than anyone else.

I should like to say a few words in conclusion upon the offering of prizes by societies. Were it not for the encouragement thrown out by Chrysanthemum societies in the shape of valuable prizes the Chrysanthemum would not be nearly so popular amongst exhibitors. Valuable prizes have this year been offered by societies, and in most cases such societies have had the best shows. To my mind there is no kind of prize offered which is so likely to increase the popularity of any society as that of challenge vases accompanied with substantial money prizes. Such prizes create an interest second to none in the Chrysanthemum world; but, again, it is a mistake for any society to offer too many even of valuable challenge vases. Competitors tire of the tremendous strain which is placed upon them for the whole time which the vase is in their possession after winning it the first year. Societies know this, and act accordingly: therefore it is well to change the mode of offering prizes. Challenge vases make societies popular, and will also do much towards rendering them unpopular with exhibitors.—E. MOLYNEUX.

## TWELVE GOOD PEARS.

THE following twelve varieties of Pears is a suitable selection for providing good fruits throughout the season:—Williams' Bon Chrétien succeeds best as a pyramid; Beurré d'Amanlis, pyramid, or an east or west wall; Louise Bonne of Jersey, pyramid, on an east or west wall, but best on a west wall; Beurré Superfin, pyramid or west wall; when grown as a pyramid the fruit takes on a russet appearance, when the flavour is delicious; to my taste it is the best Pear of its season. Marie Louise is a good successor to the above, and needs no comment, as its merits are well known; it is good

either from a wall, standard, or pyramid. Doyenné du Comice succeeds under all forms of culture, and is about the best November Pear. Beurré d'Arenberg is best from a south or west wall. Glou Morçeau is good on a south or west wall, although I have known it delicious from a standard in the neighbourhood of London. Josephine de Malines does well on a south or west wall, where it is, to my mind, the best flavoured Pear in existence. Winter Nelis, on a south or west wall; flavour delicious. Easter Beurré, from a pyramid or a wall. Bergamotte Esperen, on a south wall. The only doubtful Pear in the above is Easter Beurré, but where it does well it is well worth growing.

In addition to the above we grow the following late Pears, which are good:—Nouvelle Fulvie, Knight's Monarch, and Olivier des Serres. This Pear could be substituted for Easter Beurré where that does not succeed. Beurré Hardy and Thompson's are good Pears for the end of October. By adding the old Jargonelle, which everybody knows, we have eighteen as good Pears as can possibly be planted. The above were selected from upwards of 200 varieties, and grown under various conditions and aspects.—A. YOUNG, *Abberley Hall Gardens, Stourport.*

### EARLY FORCING—FROST AND ITS EFFECT.

EARLY frosts are looked upon with some misgivings by the majority of cultivators, and those that appear early in autumn prove very detrimental to late-flowering plants and many vegetables; but it is not to these that I intend to allude, but to such as we have experienced this year during the early part of November. Frosts varying from 7° to 14° thus early in the season may be regretted, when they stop for the time being the digging and general clearing up of the garden, but I hope to show that they are more beneficial than otherwise. The harm that frost may do during the early part of November to vegetation is more than compensated for by the advantages it confers upon cultivators who have early forcing operations to conduct for the supply of fruits, flowers, and vegetables as early in the season as possible. There is a growing tendency to start fruits such as Vines and Peaches, various flower roots, early vegetables, such as Rhubarb, Seakale, Asparagus, as well as hardy flowering shrubs, as early as possible in the season in the hope of being before our neighbours, or at least as early. Old practitioners rarely err in this matter, but younger men in their eagerness to outstrip others often find that instead of success their efforts prove futile.

At this period of the year, amongst the most important things that engage our attention are Vines and Peaches for the supply of early fruit. Much can be done in their preparation by training them to grow earlier each succeeding year by starting them a few weeks or a month earlier; but there is a limit to this, and if it is exceeded failure or partial failure is the result. The fact cannot be overlooked that early forced plants retain their foliage for a much longer period than those that are started later in the season. If we glance at Vines or Peaches started at the end of November or the beginning of the following month how much sooner will they lose their foliage—if it has been well cared for—than Vines or trees that have been started two months later. This will show at a glance that the trees in many instances are robbed of a season of complete repose that is essential to their well-being. Very frequently the trees in these early houses, especially during mild autumns, have not gone properly to rest before they are subjected to counter influences to start them again into growth. What is the result? The flower buds fall from Peaches, and the bunches of Vines invariably turn up, and eventually wither. Very often instead of such disasters teaching a practical lesson they are attributed to other causes, and not unfrequently to the immature state of the wood. Such conclusions are generally erroneous, for the wood has had a better chance of ripening thoroughly than that on trees in second, third, or even late houses, and yet on these the buds remain or the branches lengthen as the case may be. The cause of such failures can in most cases be traced to the trees never having properly rested before it has been considered time to start them again. Vines in pots grown on the ordinary method, that would under favourable circumstances do well, often fail simply because they have been robbed of a season of rest. One of the greatest mistakes that can possibly be conceived is to start such plants at a given time whether they are ready or not. In this matter the season must be taken into full consideration, for upon it depends in a large measure when the Vines or Peaches completed their growth. To delay starting such even a month, and then push them forward more rapidly than is necessary under ordinary circumstances, will prove less injurious to their health than to start them into growth really before they have completed the work of the previous season. Starting too early and too quickly is a great

mistake, and with Peaches often results in the flowers expanding in a weak or crippled state.

Another mistake in the management of early houses for forcing is closing them so as to exclude early frosts. No doubt this is due in a large measure to the practice of storing plants in them; to keep them safe the house is closed, and not allowed to fall below 40° perhaps. I have failed from such causes, and hope to prevent others doing so. Early houses of this nature should be kept free from plants, or only those placed in them that will bear a slight frost without injury. If the ventilators are left open and the trees subjected to a slight frost it will do them no harm, but the most satisfactory result will follow. Frost will decide matters, and send the trees to rest, after which they may with safety be started into growth. It will be found that they will start freely, even vigorously, without that risk of failure that otherwise is liable to follow. A lengthened rest is unquestionably of benefit, but this cannot be accorded to plants required for early work, and therefore it is important that the rest they receive should be, if even for a very short period, as complete as possible.

In passing, Strawberries may be considered. House plants say early in November, when the early Peach house or vinery has been cleaned and prepared for starting, and exclude frost from them after they are placed under cover—supposing they have not been exposed to it before. These, for the purpose of early forcing, may be layered first in 5-inch pots, thus being practically confined at their roots. Keep them rather dry to induce rest, and what will be the result? Plants left outside in 6-inch pots without this trouble in preparation, and exposed to frost, then housed, say a month later, will be as early as the others, and produce double the quantity of fruit. The difference will at once be perceptible; the first plants will start slowly, the latter at once, pushing up their new leaves, and the flower stems will be stronger and thrown up above the foliage, while those of the early started ones will be weak and short, often not long enough to reach over the edge of the pot. But Strawberries are no exception to the rule. If we take Seakale and Rhubarb as examples, and leave them in the ground until the foliage has died, and then lift them and place them in the forcing house, they will prove stubborn, and often refuse to move for weeks unless severe measures are taken to force them into growth, and even then the growth is weak in comparison with what it should be. If instead of placing them in the forcing house they are left upon the surface of the ground, or placed in any convenient position until they have been exposed to frost, and then introduced, they will come away strongly and at once. I have placed roots treated in this manner by the side of those started a month before, and been able to gather from the latest introduced ones long before I could from the others.

Some are even more difficult to start than any that have been enumerated. For years I have had Lily of the Valley from the 3rd to the 5th of November, but this was not attained by lifting the roots and placing them in strong heat. It was the result of assisting plants to make and ripen their growth under glass, and then enjoy as complete a rest as we could force upon them. Any attempt to lift plants and force them for such early flowers would only prove a failure. The majority do not go in for such early forcing as this, and it is not essential, but in our case it was a favourite flower, and one of the essentials of the establishment. If plants are dug up before they have been exposed to frost, or imported plants introduced, either crowns or clumps, they will refuse to start. I have obtained imported single crowns, placing them in strong bottom heat, and after two months of this treatment as they refused to start they were turned out, and they flowered freely the following July. But subject home-grown roots, or imported ones, to a week's frost in pots, boxes, or pans, with their crowns fully exposed, and then introduce them; they will start readily and in a short time produce their flowers. Spiræas, Lilacs, Guelder Roses, Rhododendrons, Ghent and mollis Azaleas, and other plants of a similar nature also refuse to start early before they have been exposed to frost sufficiently severe to bring growth to a complete standstill. It will be seen then and can be proved by all, that commencing these operations too early is a great mistake and may lead to failure, while a few weeks' patience and the beneficial effects of frost will bring them into a satisfactory condition for starting. Early frosts will always be welcome to those engaged in early forcing on a large scale. No doubt a sudden change from mild weather to such frosts as I have mentioned are injurious to many plants. Hollies may be taken as an example, and it is clear that they grow until very late in the season unless they are prematurely brought to a standstill, by lifting them at a certain stage or by these early frosts. Plants lifted in August and September seldom lose a leaf through these early frosts, but unlifted ones do, for a large percentage of leaves near the extremity of the shoots fall. The plants are brought to a standstill, and the supply to these immature leaves being cut off, they naturally fall.—A NORTHERNER.



## NOTES FROM CHATSWORTH.

A MOST enjoyable ride is that from Sheffield to Chatsworth *via* Froggate Edge, especially on a bright autumn morning. The distance is fourteen miles. Leaving the smoky town behind, we soon begin to arrive at the residences of the wealthy manufacturers and pretty villas with well-kept lawns in front, most of them commanding a good view of the Yorkshire and Derbyshire hills. The fences for miles are built loosely of stone, and present a peculiar appearance when seen from the summit of a hill. The roads, which are in capital condition, are only repaired during the winter at a time when the coach does not run. Passing through the moorland belonging to Lord Fitzwilliam, the Duke of Rutland, &c., Froggate Edge is reached, and Surprise Valley, most appropriately named, for the traveller passes all at once among great rocks 14 feet or more in height, with Bracken growing luxuriantly on one side and open scenery on the other, with the winding river Derwent, where trout abounds under strict preservation. It would be almost impossible to exaggerate in a description of this delightful journey, and no wonder that the artist and lover of Nature make excursions to find shelter under the roof of clean cottages and farm houses along the route.

Arriving at Baslow, and alighting at the Devonshire Arms, a ten minutes walk brings us to the Chatsworth Park, and after a stroll through a portion of the same we reach Mr. Owen Thomas's house, the worthy superintendent of the celebrated gardens, which, under his guidance, I had recently the pleasure of inspecting. In the front of his house, beyond a closely shaven lawn, is a charming rockery of Derbyshire stone, containing many choice alpine and herbaceous plants, backed up with Rhododendrons and other shrubs. The large house and summer home of Victoria Regia and other Lilies was just cleared and prepared to receive a grand collection of Chrysanthemums, which are, no doubt, making a fine display by this time. These and many other softwooded plants are cultivated largely to come in during the winter time when the family is at Chatsworth. Another house having a north aspect is utilised for retarding any plants that are likely to bloom too soon. Bouvardias, Eucharises, Pancratiums, Poinsettias, and Thyrsacanthus are grown in great quantities, as they are useful for cutting, and help to decorate the rooms and vestibules of the stately mansion. Amaryllises, too, are numerous, and are already making fine growth. *A. Princei* Albert has been flowering for some time. Several of the houses were enlivened with its showy blooms.

The Pine stoves, Peach houses, vineries, &c., deserve much more than a mere passing notice did time permit. In four houses of Black Hamburghs young rods were trained up last year, and each cane has produced ten fine bunches, averaging 2 lbs. weight each, the berries being fine and well coloured. Muscats Golden Queen and Mrs. Pearson were exceptionally good. The earliest Peach trees had been started, and from these fruit will be gathered in April, Royal Ascot ripening about six weeks before Princess of Wales. Many forcing houses are required for growing Kidney Beans, Strawberries, Tomatoes, pot Vines, &c. The kitchen garden is cropped in a most satisfactory manner, a large breadth of Snow's Winter Broccoli being remarkably fine.

The famous conservatory is situated some distance from the fruit houses and kitchen garden, being close to the historical mansion. On entering, some grand examples of Fern culture in baskets were conspicuous. These were 5 feet or 6 feet across, and suspended they made a charming show, with the splendid specimens of Tree Ferns, Palms, &c. *Musas* are grouped together in various parts of the building, and represent twelve varieties, *Musa Cavendishi* fruiting freely. *Begonia fuchsioides* on pillars was in bloom and very effective, *Dendrobium speciosum* growing apparently wild, the roots clinging to the rockery as it might in its native home, *Renanthera coccinea* is also luxuriating in the same house. Although the place is nearly 70 feet high, the top of one of the Palms has forced its fronds through the roof. The pretty Hawthorn-scented *Aponogeton distachyon* was growing and blooming freely in a tank, and *Nertera depressa* clothed some of the tall Fern stems.

To go into a house devoted to Cape Heaths is now a rare treat, for besides those grown for exhibition, few people afford them the space they once occupied, but at Chatsworth they have lost none of their prestige, as the large specimens and excellent condition of the plants amply testify. Several large houses are devoted to Orchids, and these alone are worth a long journey to see. In the Vanda house, growing in large tubs of water, are two grand specimens of the Lattice Leaf (*Ouvirandra fenestralis*) with many long and broad leaves. *Vanda cœrulea* is well grown and flowering freely. This is one of the most handsome autumn flowering Orchids. The other species are represented in very large plants well furnished with foliage to the base, *V. Batemanni* having three strong growths. *V. suavis*, with the Chatsworth and Drumlanrig varieties, are very conspicuous. *V. tricolor formosa* and other forms, together with *V. cœruleseens*, *V. multiflora*, *V. Parishii*, *V. insignis*, *V. Roxburghii*, and *V. teres* are thriving admirably. Among *Augræeums*, *A. eburneum* and *A. sesquipedale* were showing spikes of bloom. *Camarotis purpurea* also shows that the treatment in moderate heat and moisture suits it well, and the lovely *Aerides vandarum* too.

The collection is strong in *Cœlogynes*. *C. Massangeana* had been blooming some time, with spikes carrying twenty-two blooms each. *C. cristata*, with the Chatsworth and Trentham varieties, are enormous masses bristling with flower spikes; they will be fine in a few months time. *C. speciosa major* is nearly always in flower. The *Cypripediums* are in quantity, but the most noticeable in bloom at the time was

*C. Spicerianum*, one plant with longer foliage than the rest bearing much the largest flowers. Huge plants of *C. Harrisianum* and *C. insigne* Maulei were also in fine condition. *Cymbidium Devonianum*, *C. eburneum*, *C. Lowianum*, and *C. Mastersi* are well grown. The *Dendrobium* house contains some of the best and most showy species. *D. Dalhousianum* would be prized by some of the large exhibitors could they possess them in the same condition as they are at Chatsworth. The famous plant of *D. nobile*, which so many admired at the Orchid Conference, is divided into scores of smaller ones, but there is another of nearly the same size, which perhaps will be quite as gay in its turn. Many other species are at rest in a cooler house. *Pleiones* and deciduous *Calanthes* are a great feature. The latter, which include *C. Veitchii* and varieties of *C. vestita*, are grown in large pots or pans, with about two dozen pseudo-bulbs in each, and these will yield a supply of blooms till the end of January. Few *Cattleyas* or *Lælias* were in bloom, although all were showing plenty of sheaths. *Lælia anceps* varieties, with good plants of the rare *L. a. Dawsoni* and *L. autumnalis* will be among the first to open. Of *Oneidiums*, *O. Jonesianum*, *O. tigrinum*, and *O. Rogersi* were in bloom, and in another house, amongst healthy plants of *Odontoglossum Phalaenopsis* and *O. vexillarium* were some fine pieces of the autumn blooming form of the latter. *Masdevallia amabilis*, *M. tovarensis*, and *M. Veitchii* were also assisting to make the house gay. All the cool Orchids receive the same amount of care and attention as the others, and it is almost impossible to find a sickly plant amongst them. *Epidendrum vitellinum majus*, *Odontoglossum Alexandræ*, *O. Hallii*, *O. Pescatorei* and *Rossi majus*, with a host of others, are clean and healthy. *Disa grandiflora* is grown in a cool airy house. The plants are divided, and the strongest selected and potted together. That the treatment is understood is proved by the fact of a single spike carrying eleven flowers this year.

*Phalaenopses*, *Nepenthes*, and *Sarracénias* ought not to be forgotten. Of the latter interesting plants *S. purpurea* is richly coloured, and measures over 2 feet across. This gives but the faintest idea of the treasures under Mr. Thomas's care, and to him I tender my best thanks for his kindness and the information afforded.—G. W. CUMMINS.

## GRAPES AT EAGLE HOUSE, DOWNHAM.

A VERY large range of vineries, planted and under one man's care for twenty-one years, is not a pleasant charge to take, especially when the proprietor remarks, "the crop, bunches, and berries get less every year." The first step was in the spring (though late) to reduce the large Vine borders outside, in some cases cutting the borders in two, then working up carefully towards the roots with a fork, at about 3 or 4 feet from the stems, the roots were laid in, having new compost ready for use. Thomson's Vine manure was also largely used for top-dressing then, and again during the summer, with the result that there has been a better crop, larger bunches, and better berries for some years. The laterals are stronger, foliage very fair for size and stoutness, but in the late house especially more fire was wanted, now remedied for another season by adding two additional rows of pipes. The early Black Hamburgh, Buckland Sweetwater, and Muscadine were very good, but as it is with the present hanging crop I have to deal I will commence at once.

Black Hamburgh, Mrs. Pince, and Lady Downe's are grown in a long lean-to for late work. As all well know, no matter how good the first-named is, there is a falling off in appearance by hanging. Mrs. Pince was very well coloured, the bunches small, but a full crop and with fair sized berries.

Lady Downe's, however, I will describe rather fully. First of all the foliage shows too much "cold green," not natural autumn tints for this advanced period of the year, and according to the blackness of the Grapes the foliage should be well coloured. Foliage as it falls, though dead round the edges is, if even yellow, not a natural tint, showing very plainly the want of fire, especially in the autumn. Then I take it that the evils arising from this affect the wood not only for this present crop, but also for the next, though to a certain extent the next year's crop may be benefited by proper cultivation. Also, no doubt, last year's treatment told its tale on the present crop. Now this is what I am driving at, a good, not heavy crop of Lady Downe's, with the best berries I have yet seen this year, standing thus—this, too, with fertilising—sound berry, large, three stones, same size berry on same bunch, shrivelled, three stones. Smaller berry with two stones of both kinds, at once telling me that however desirable it is to obtain the full complement of stones, these stones will not keep berries from shrivelling. I must say the stones in both kinds of berries were in each case perfect. I have requested Mr. Strong to forward for your inspection a sample of Lady Downe's.

Of course I attribute this premature shrivelling to want of heat in the last stages of colouring, especially cold low temperature after a hot bright day. Mrs. Pince stands about the same, and in this as in Black Hamburgh I found any, or very few, four-seeded Grapes. Muscats are now the best I have seen this year, a good crop also, the majority will keep. Here I find in the largest berries three stones, and what is particularly vexing to me is the same number and as good stones in a shrivelled berry. I can assign no cause for this at present. I must, however, say only a few shrivelled berries are present, nor do they look like going worse; plenty of fire was used here. I saw a splendid rod of Duke of Buccleuch fit for bearing, but being in an outside

border I fear it will not do well. The Muscats are inside and out, and there are good crops on both.—STEPHEN CASTLE, *Manager, West Lynn.*

[The samples of Lady Downe's are, as our correspondent describes them, one bunch having fine berries of superior, the other small and shrivelled berries of inferior quality. The largest berry in the best bunch contained five seeds, the smallest in the same bunch one seed, the majority two or three seeds. The smaller and shrivelled berries in the inferior bunch also contained two or three seeds, fertilisation thus appearing to have been equally effected in both cases, and the condition of the berries influenced by the condition of the Vines or differing treatment. We have seen hundreds of large Grapes with few seeds, and smaller berries crowded with them, therefore conclude that something in addition to seeds is necessary for the production of large berries, but given the flesh-forming requisites may not seeded berries be expected to attain a larger size than the seedless? Some naturally large berried varieties have few seeds, the Dutch Hamburgh for instance, and others might be named. The subject is an interesting one worthy of attention and discussion. What are the flesh-forming requisites? Would these large Grapes with few seeds be larger still if they had more.]

#### AMARYLLIS RETICULATA.

ALTHOUGH this plant is usually grown as a stove foliage plant it is far more attractive when in flower. The flowers are large and of a beautiful rose-pink colour, delicately veined with dark pink, with a white stripe down the centre of each petal, contrasting well with the dark olive green leaves, which also have a broad pearly white stripe running down the centre of each leaf. To induce it to flower it requires rather different treatment from the majority of Amaryllises. The plant being an evergreen it is very injurious to dry it off, but it requires a distinct period of rest, not absolutely withholding water, but giving just sufficient through the winter months to keep the foliage from decaying. As the days lengthen and the temperature is raised more water will be required, and by the end of May or the beginning of June they will commence throwing up their flower spikes. When in flower they last for a considerable time if taken to the conservatory.

They do not require to be potted very often, once in three or four years being quite frequently enough. Our plants are potted in three parts loam and one part leaf mould, with a good sprinkling of silver sand. Four bulbs in a 32-sized pot produced seven spikes, which had a total of fifty flowers. I counted as many as twenty-seven open at one time, and we have several smaller plants which flowered equally as freely, and they have flowered for a number of years in the same way. They are grown in an intermediate house, which I think is the reason they flower more freely than plants grown in a stove temperature all the year through.—A. WHIBLEY, *Osborne House, Eastbourne.*

#### EXHIBITING—JUDGING BOUQUETS.

As an humble aspirant for exhibition honours I have read with interest the article on winning and losing prizes in a recent issue, also the remarks of Mr. G. Garner on judging hand bouquets. Both these articles are closely allied to each other, and as I have had a little experience in winning and losing prizes, and exhibiting hand bouquets, I am tempted to offer a few remarks on them. First, I will take the winning and losing prizes in my own experience, and here I think lies the test of an exhibitor's temper. I have many a time left the exhibition tent making sure of success when the exhibits have been close, but even my opponent has given me best, but on returning after the judges have been round have found my calculation entirely upset. The first quarter of an hour afterwards is always the worst. When the storm has blown over we have generally settled down to our fate, and, like Mr. C. Turner, resolved to try again. Once I must confess to having a very long sulking fit over an exhibit, but the error was so glaring that it was the talk of the town for a very long time after, and even now it is referred to at times, and I am only sorry I did not call in the committee as suggested in your article, as by so doing it would have saved all the unpleasantness that has occurred since. I would suggest to all exhibitors (in glaring instances of error only) to have the decision of the committee on the day, and while the exhibits are on the table, rather than leave it and brood over it for months; but I cannot help thinking that mistakes in judging would occur less often if the committees of shows would choose the men best fitted to judge the respective exhibits. I think some allowance should be made for exhibitors who are disappointed, and not too much notice be taken of a little outbreak of temper at the time, provided it does not last long, as no one knows but the exhibitor the strain that is put upon his nerves for a day or two before the show, and so on hour by hour till the work is done and the tent cleared. I can only say if a novice feels inclined to condemn any one of them let him enter for one or two good prizes at the next show and see for himself the effect a defeat would have on his stock of patient endurance.

Dealing with the remarks on judging hand bouquets, I entirely agree with all the remarks Mr. G. Garner makes as to bouquets being a good feature in any Show. Then, as to the Fern being inserted after the bouquets are staged, I hold with him it is entirely wrong, and the time was when I would have scorned the action, but evil communications corrupt good manners. I soon found if I was to win I must do what other exhibitors do—that is fill up the bare places with fresh Fern fronds, or if a piece of Fern was faded take it out and insert a fresh piece, both of which practices ought not to be allowed. I have seen a

wreath of white flowers exhibited and take a prize with only the centre row of flowers fastened to the ring and then laid on the board, and the other flowers and Ferns added the same as making up a table decoration, and no exhibitor in the same class, though beaten by it, was mean enough to expose the trick. I have also competed with bouquets that have been partly made, and the "stick ups," as they are termed in the trade, inserted where required, simply by sticking the wired flowers into the base of the bouquet and have taken the beating (not in silence), but without public complaint, as that course would only create ill feeling and do no good. Any of the above tricks could easily be prevented if the judges would go thoroughly into the merits of a properly made bouquet, which I have been taught to consider was one where each flower showed itself fully, without being crowded, not comprising more than three or four different shades of colour, to be very light with a small handle, and every part properly fastened. Of course the flowers used must depend on the taste of the exhibitor, and he must take his chance in the competition accordingly; but I have seen bouquets win this year time after time with at least eight different colours and sometimes as many as twelve, and on one or two occasions when they did not win I was asked for my opinion, and I had to point out Eucharises drawn in so that the flowers formed quite a cup, and other flowers packed accordingly. The bouquets were very pretty, and the best flowers that could be had, which I have considered have won the honours. I have also seen bouquets win containing flowers in the last stage of decay. On any of these points I should like to be put right as to what I am to do to be sure of gaining a first in any future contest.

Now, as to Mr. Robson's rules. Rule 1 I should like to see carried out at all shows; that would soon put a stop to tricks. Rule 2.—As it is so long ago since Mr. Robson wrote them, the present neat papers and handles not being then obtainable, this ought to have all words taken out from "shown to foliage." Rule 3 is not necessary I should think. Rules 4, 5, 6, and 7 are quite right; or in words I do not think anything can be added to them.—A LEARNER.

P.S.—Upon one occasion my contribution was placed behind a bouquet, which on critical examination we found had a handle about as large as that of a grub-axe, that I am sure no lady could have carried five minutes without making her hand ache.—A. L.

YOUR correspondent Mr. Garner does well in bringing forward the above subject, since so much diversity of opinion exists as to points of excellence in the composition of hand bouquets, notably so in the case of some recently exhibited in several well-known towns in the West of England, where size alone seems to constitute excellence, and this idea having gained ground, the result has been some monstrous exhibits, many of them frequently measuring 24 inches in diameter, and in one case 28 inches. How is this state of affairs brought about? Certainly not on account of the prize money, which, if gained, would not cover the cost of one-quarter of the flowers used, but simply for the honour; and as the only way to obtain that honour is, according to the present absurd idea (favoured also by the Judges) to make and exhibit one larger than any other competitor, the result has been an exhibition of some of the most ridiculous hand bouquets at the recent Bristol Chrysanthemum Show it has been my lot to come across. Whether or not the Society will see fit to insert a specification in their prize schedule for another year, it is to be sincerely hoped that the Judges will, by their decisions, give rise to a better idea of excellence. Although no doubt the evil will right itself eventually, as it is evident the climax has been reached, and it will be only the few that can afford the expense of procuring so large a quantity of choice flowers that will be 1 ft in the field, and instead of the array of bouquets generally brought together there will only be just one here and there having a "walk over," and these, finding they have no opposition, will gradually reduce the size. As regards the judging of hand bouquets, I consider that a specification should be made both as to the limit of size, and also that the Judges should be at liberty to test the stability of its construction, and unhesitatingly reject all such as are made on what I should term the "pincushion style," in which the flowers are stuck loosely on a wire network frame stuffed with moss, and which if inverted after the flowers are inserted would result in a total wreck.

Rules 1 and 4 of Mr. J. Robson's list, with a limit as to size, are in my opinion the ones that should be observed most in judging hand bouquets.—FLORIST.

#### NOTES FROM ASHTON COURT.

THE month of November is not the best time in the year to visit gardens, whether large or small, with a view to admire the natural beauties of the place, or to inspect the valued treasures that find a congenial home in the glass structures of modern gardens, but the improved methods of constructing and heating glass houses render it a matter of comparative ease to keep up a constant supply of choice flowers even in the depth of winter, and when visiting such extensive and well managed gardens as those under notice we are sure to find much to interest and please even in the dreary month of November. At Ashton Court a few weeks since I was particularly struck with the fine stock of winter-flowering plants then in flower or ready for flowering between the present time and Christmas. A long Peach house was principally occupied with a fine collection of Chrysanthemums grown for supplying cut blooms and for conservatory decoration, and a stock of plants more suitable for the purpose can scarcely be imagined, among them being most of the best varieties in cultivation. The foliage on the plants was good to the rim of the pots, and the flowers very bright and

fresh, without which *Chrysanthemums* lose much of their beauty. Some of the plants had been disbudded, leaving one flower to a shoot, while on others the flowers appeared not to have been thinned at all, and were carrying one good central flower with numerous smaller ones clustering around—quite a nosegay in themselves. Those in search of cut flowers might cut and come again. A few plants were carrying four or five blooms only, and many of them would do credit to any exhibitor's stand, some flowers of such varieties as Alfred Salter, Queen of England, L'Adorable, Cullingfordi, and Empress of India being very fine. A shelf along the front of this house was filled with strong healthy *Cinerarias* in 7-inch pots, which will doubtless make a grand display during the spring months.

After inspecting the occupants of the Peach houses we came to some useful span-roofed houses and pits, which afforded capital facilities for growing the various subjects with which they were filled, but they are found to have one drawback, which is, that the stages on each side of the central walk are rather too wide to admit of the watering being quickly and carefully performed. One of these houses contained fine single and double *Pelargoniums*, which were flowering grandly, the best varieties for winter flowering. Some of the plants were carrying enormous trusses of brilliant scarlet, and when grown to such a high degree of perfection *Pelargoniums* must be placed in the front rank of winter blooming plants. That old and popular variety, *Guillion Mangilli*, which Mr. Taylor when at Longleat brought prominently forward, was grown in quantity, and although in company with some of the best new varieties, was flowering as freely as any of them. Lord and Lady Chesterfield were carrying large trusses of deep scarlet coloured flowers; *Heroine*, the best of all whites for winter work, was in fine condition; *Madame Thibaud*, a grand flower of deep rich colour; *F. V. Raspail* and *C. H. Swinstead* were represented by very large trusses with pips of enormous size. Many other good sorts were grown, but I only notice a few of the most striking. The next house was filled with *Indian Azaleas* and *Begonias*, which were being pushed on for early flowering. Another was principally occupied with *Poinsettias*, which were just beginning to unfold their scarlet bracts, and very promising plants they were, having good foliage to the rim of the pots. *Bouvardias* and *Carnations* find a congenial home at Ashton Court. Large quantities of the best varieties are planted out in span-roofed pits, and are found to be indispensable for supplying a good succession of their highly prized blooms. Some of the most noticeable among them were—*Hogarth* (scarlet), *Victor Lemoine* (double scarlet), *Vreelandi* (white), and a small but extremely pretty and useful one named, *Rosea oculata*. Among *Carnations* that well known variety, *Miss Jolliffe*, was yielding large quantities of its lovely salmon coloured flowers. *Pride of Penhurst*, *Vulcan*, *Valencia*, *White Swan*, were all showing good blooms, and a few plants of that deep rich coloured variety, *Mrs. Keen*, were grown in pots. Cucumbers and Tomatoes filled two other houses. The former were just coming into bearing for winter use, while the latter, although the plants had been fruiting during a great part of the summer, were still carrying a good crop of smooth even sized fruits. After looking through these houses my impression was that they were turned to good account by skilful and systematic management, and Mr. Bethel and all connected with them are to be congratulated upon the fine stock of various plants with which they are filled.

The family not being at home the conservatory and winter garden were not in dressed attire, but many of the permanent objects which were planted out were in excellent health and vigour. Large plants of *Camellias* were beginning to unfold their ever-welcomed flowers, and a fine plant of *Cassia corymbosa* covering great space on the back wall was very effective with its bright yellow flowers, while on the side stages were arranged some well-grown *Salvias*, *splendens* *Bruanti* being grown in large quantities. This variety being very similar in appearance to the old *splendens*, but much more compact in habit of growth, and consequently more suitable for some purposes. In the plant stove were good plants of *Palms*, *Crotons*, *Dracenas* of sizes most useful for decorative purposes, for which use the plants are grown. In an adjoining house were capital specimens of *Vandas*, *Aerides*, and many other choice *Orchids*. *Odontoglossums* and other cool house *Orchids* filled a shelf near the glass in a fernery, and several good forms of *O. Alexandræ* were flowering well. In the same structure were some capital *Roman Hyacinths* in full beauty, and their pearly white flowers are extremely useful either for cutting or for use in pots during the autumn months.

I have simply recorded a few facts which came before my notice when looking round these well-known gardens on a dull November day. But although the weather was dull and cheerless, the hearty welcome I received there and the many good things that I saw rendered my visit a most enjoyable one.—H. D.

### THE GREAT VINE OF KINSELL.

THE Black *Hamburgh Vine* of Kinnell, a former seat of the *Macnabs* near Killin, at the western end of *Loch Tay*, in *Perthshire*, is one of the great sights of the *Breadalbane* country. It is now the largest specimen of a growing *Vine* in the United Kingdom. The *Marquis of Breadalbane*, on whose grounds of *Auchmore* it is situated, is justly proud of this splendid *Vine*, and has arranged that it may be seen by the public every Wednesday between the hours of ten and two o'clock. When we saw it this autumn, about 500 bunches of luscious *Grapes* were hanging from it, which, at an average of 2 lbs. per bunch, means about half a ton of *Grapes*. The yield of this prolific *Vine* in recent years is interest-

ing. In 1879 the yield was 1179 bunches; but 376 bunches being taken off green, only 803 were left to come to maturity. In 1880 the yield was 1274 bunches, 560 taken off, and 714 left to mature. In 1883 the yield was 2102 bunches; in 1884, 2172; in 1885, 2844; in 1886, 2868; and in the present year it yielded 2548 bunches, 500 only being left to mature. It now fills a glass house 270 feet long, is growing as rapidly as ever, and is remarkably healthy looking. The stem, a little way above the ground, before it sends out its branches, measures 1 foot 10 inches in circumference. It shoots out for 5 or 6 feet before it runs to branches. The only extra "food" the soil now receives is old bones broken to about half an inch. It is now about fifty-six years since it was brought as a young and healthy shoot to Kinnell. It may be mentioned that the famous *Black Hamburgh Vine* at *Hampton Court* is less in size than this *Kinnell Vine*, the leading branches, according to a recent authority, being about 110 feet long; but its principal stem is 38 inches in circumference.

The story of the *Vine* as told by the oldest inhabitant is briefly this: There happened to be an English shooting-tenant in one of the *Macnab* residences called *Auchlyne*, in *Glendochart*. He was fond of sport, but at the same time had paid so much attention to horticulture as to organise a glass house in the garden, in which this shoot of the *Black Hamburgh Vine* brought from the south was planted. This sporting tenant having suddenly gone abroad, the healthy shoot was removed to *Kinnell*, near *Killin*, and planted there. It took root and flourished fairly well. A genius of a gardener, *Robertson* by name, now took means to aid its growth. He had a substantial subsoil of leaf mould brought from near *Finarig*, the burial place of the *Breadalbane Campbells*, on the shores of *Loch Tay*. This soil he prepared in the usual way for use, and with his best gardening skill and experience, the roots were sunk in this compost. The first year after this treatment the results did not appear very satisfactory; a few scraggy *Grapes* were the total yield. But immediately afterwards it began its remarkable growth and fruit bearing, until it has attained its present magnificent condition. It is worth adding that the fruit of this *Vine* is not sold or selfishly used in any way, but with commendable liberality the *Marchioness of Breadalbane* sends, perhaps, a hundred bunches at a time of these luscious *Grapes* to the hospitals and infirmaries of *Edinburgh*, *Glasgow*, and *Dundee*.—(*Chambers's Journal*).



THE Grand Quinquennial Exhibition of the SOCIÉTÉ ROYALE D'AGRICULTURE ET DE BOTANIQUE OF GHENT will be held under the immediate patronage of the King and Queen of the Belgians, from the 15th to the 22nd of April, 1888. The Programme, which is a rich one, is now before us, and many attractions are held out to induce exhibitors from all parts to enter for competition. We have no doubt this, which is the twelfth of the series, will sustain the great reputation which the Society has so long enjoyed for the excellence of their exhibitions.

— THE NATIONAL ROSE SOCIETY.—Arrangements have been made to hold the Metropolitan Exhibition at the Crystal Palace on the first Saturday in July, and the Provincial Show at Darlington somewhere about the 17th of the same month.

— AT the Royal Horticultural Society's Gardens, Chiswick, on Thursday last A SALE OF TREE FERNS was held by order of the Commissioners of the Indian and Colonial Exhibition; but though many of the specimens were very handsome, with stems 4 feet high and good crowns of fronds, they only realised from 10s. to 20s. each, with a little more in a few exceptional cases, and smaller Ferns were sold as low as 1s. each. A large *Todea barbara*, with a stem 3 feet high and of great breadth, the fronds 10 feet long, realised £3, and two pans of the scarce *Trichomanes reniforme* were sold for 10s. We understand that the total amount did not exceed £100.

— THE ROYAL HORTICULTURAL AND AGRICULTURAL SOCIETY OF ANTWERP announce the following exhibitions to be held in Antwerp in 1888. An exhibition of cut *Roses* at the end of June, a general horticultural exhibition in August, and an exhibition of *Chrysanthemums* in November.

— A GENERAL Committee meeting of the NATIONAL CHRYSANTHEMUM SOCIETY was held on Monday at the Old Four Swans, Bishopsgate Street, the following being present:—The President, E. Sanderson



Esq., in the chair, and Messrs. R. Ballantine, Wm. Holmes (Hon. Sec.), J. R. Starling (Treasurer), E. C. Jukes, B. Wynne, G. Gordon, Lewis Castle, G. S. Addison, H. J. Jones, R. Owen, J. P. Kendall, R. Dean, C. Gibson, J. Marllin, Harman Payne, G. Stevens, &c. Arrangements were made respecting the payment of extra prizes at the Westminster Show. Twenty-six new members and Fellows were elected, and it was announced that the Marchioness of Downshire had consented to become a patroness of the Society. It was decided to hold the annual dinner on December 13th, and considerable discussion took place as to where it should be held. It was ultimately resolved to appoint a Sub-Committee to make the necessary arrangements and announce their determination as speedily as possible. We have since heard that it has been decided to hold the dinner at Anderton's Hotel, Fleet Street, upon the date named above, at 6 P.M. for 6.30 sharp. An unusually large attendance of members and friends is expected, and particulars can be obtained from Mr. W. Holmes, Frampton Park Nursery, Hackney.

— THE EFFECTS OF THE FOGS.—Few gardeners besides those who have to experience them have any idea of the injuries caused to plants by the yellow sulphurous fogs that have been too frequent in the London district lately. It is well known that Orchid flowers, especially those of *Phalenopsis*, commonly suffer considerably, but it is seldom that we see such damage as that caused within the past week or two. Plants of *Azalea indica* have had their foliage scorched as if by frost or severe fumigation, though some varieties have escaped uninjured, probably owing to the leaves being of hardy texture. *Acacia Drummondii* has, with other greenhouse plants, had its leaves similarly browned, but *Bouvardias* have suffered the most, some plants being nearly killed, while *Crotons*, *Gardenias*, and other stove plants have also experienced some of the evil results. Strangely enough *Boronia megastigma* has not been affected in the slightest degree.

— THE CHESTNUTS, GUNNERSBURY.—This pretty little suburban residence, close to the Royal Horticultural Society's Gardens, Chiswick, has interest for lovers of the *Cbrysanthemum*, as being the abode of the esteemed Treasurer of the National Chrysanthemum Society, J. R. Starling, Esq. The Chrysanthemum is his favourite flower, but it does not claim the whole of his horticultural "love." *Gloxinias*, *Begonias*, *Orchids*, and other plants have a share in his floral sympathies. The collection of Chrysanthemums numbers some four or five hundred varieties, and is especially "strong" in Japanese, which arranged in a lean-to and a small conservatory, have a very attractive appearance. A few Orchids were in bloom at the time of our visit—such as *Cypripedium insigne*, *Cymbidium giganteum*, *Oncidiums*, and *Dendrobiums*—in variety, which afforded a welcome and interesting change after the glare of colour presented by the Chrysanthemums. It may be said to be a case of gardening under difficulties with Mr. Starling, for the garden is situated on a gentle slope towards the South-Western Railway, about 300 trains a day passing the house. The soot deposited on the glass is certainly not conducive to high cultivation, therefore the success attained is all the more creditable to the genial proprietor, ably seconded as he is by his gardener, Mr. George Webb.

— "A CONSTANT READER" writes: "There is a plant of the IRISH IVY, *HEDERA HELIX CANARIENSIS*, growing on the old church tower at Machynlleth, Montgomeryshire. The tower is square and 63½ feet in height. The plant occupies two sides of the square, and covers in all 219 square yards. In our part of the country this, as a single plant, is considered a very large specimen. Would any of the numerous correspondents of your valuable paper obligingly inform me where larger plants are to be found?"

— THE opening meeting of THE ROYAL METEOROLOGICAL SOCIETY for the present session was held on Wednesday evening, the 16th instant, at the Institute of Civil Engineers, 25, Great George Street, S.W., Mr. W. Ellis, F.R.A.S., President, in the chair. Mr. C. E. de Bertodano, Dr. W. A. Bowen, Mr. F. J. Brodie, Dr. T. B. Hyslop, Prof. H. H. McMinnies, and Captain T. C. Newton were elected Fellows of the Society. The following papers were read:—(1.) "The Use of the Spectroscope as a Hygrometer Simplified and Explained," by Mr. F. W. Cory, M.R.C.S., F.R.Met.Soc. The object of this paper is to suggest as simple a way as possible of using the spectroscope as a hygrometer in order to facilitate its introduction amongst observers as a standard meteorological instrument. The best form of hygro-spectroscope as a recognised standard for the purpose of investigating and scrutinising the

changes of the three parts of the spectrum mentioned is that originally termed by Mr. Rand Capron, "The Rainband Spectroscope." It ought to have a fixed slit, and in addition a milled wheel at the side for the easier adjustment of the focus. The author concludes by giving a set of hints to observers for taking weather observations with a pocket spectroscope. (2.) "Rainfall on and around Table Mountain, Capetown, Cape Colony," by Mr. J. G. Gamble, M.A., M.Inst.C.E., F.R.Met.Soc. The author calls attention to the great, and in some respects peculiar, differences that exist between the quantity of rain that is registered on and around Table Mountain. The most striking feature is the small fall on the signal hill. The signal hill, otherwise called "The Lion's Rump," lies to the west of Capetown, between it and the Atlantic. The average annual fall there is only 15 inches, while the fall at the western foot is 21 inches, and in Capetown 27 inches. The signal hill is 1143 feet above the sea. The fall at Platteklip, on the northern slope of Table Mountain, overlooking Capetown, and 550 feet above the sea, is considerable—namely, 45 inches. The greatest fall is at Waai Kopje, about half a mile to the southward of the highest point of the Mountain, at an elevation of 3100 feet, or 450 feet below the top. Another station on Table Mountain, further south—that is, to the leeward in the rainy season, and 2500 feet above sea level, has only 39 inches. The eastern suburbs, Rondebosch, Newlands, and Wynberg, all have a comparatively abundant rainfall, 40 to 50 inches and upwards, the greater part of which falls in winter time. (3.) "On the Cause of the Diurnal Oscillation of the Barometer," by Mr. R. Lawson, LL.D. The object of this paper is to show that the diurnal oscillation of the barometer is mainly due to the combination of the earth's rotation with its orbital motion.

— MR. GILBERT DAVIDSON, Ammanford, South Wales, announces a new crimson Clove CARNATION PAUL ENGLEHEART, of which several correspondents speak in favourable terms. It is described as very hardy, of good constitution, the flowers of excellent colour and powerfully fragrant.

— PEARS AT BIRMINGHAM.—A lover of Pears writes:—"In the report you give of the late Birmingham Chrysanthemum and Fruit Show, mention is made of some of the Pears shown by Mr. Parker, the talented young gardener at Impney Hall, Droitwich. There were, however, two what I may term unfortunate omissions—viz., Knight's Monarch and Bergamotte Esperen. The former was by far the finest dish of that good old sort I have yet seen. So large were they that at first sight I might have been excused for taking them to be a rather small sample of the stewing Pear Catillac. Bergamotte Esperen was also exceptionally good. They were taken from wall trees which bore a good crop, and I am informed no difficulty is experienced in ripening both sorts to perfection. With us Knight's Monarch is ripened much earlier and better than usual, but in some districts the crops dropped prematurely."

— THE CHISWICK GARDENERS' MUTUAL IMPROVEMENT SOCIETY, which holds its weekly meetings in the Council Room of the Royal Horticultural Society at Chiswick, is giving ample proof of its vitality and usefulness. On November 16th, Mr. Sidney Summers, foreman at Chiswick, read a practical and excellent paper on "The Culture of Tomatoes;" on November 23rd Mr. G. Barry contributed an essay on "The Education of Gardeners," which dealt with several important and interesting matters. On November 30th Mr. W. Stanton will give a paper on "The Chrysanthemum;" December 7th is devoted to a paper on "Plant Marvels," by Mr. Leonard Barron; Mr. T. Bones, on December 14th, will deal with "The Cultivation of Vegetables." Mr. Alexander Dean and others have also promised papers on various subjects. Such gatherings, with the discussions, cannot fail to be advantageous to young gardeners in many respects.

— GLASGOW AND WEST OF SCOTLAND HORTICULTURAL SOCIETY.—The Secretary, Mr. Franc Gibb Dougall, informs us that the Flower Shows of this Society for 1888 are as follows:—1, spring, in City Hall, Candleriggs, Glasgow, on Wednesday, 28th March; 2, summer, within the International Exhibition, Kelvin Grove Park, Glasgow, on Wednesday, 11th, and Thursday, 12th July; 3, autumn, within the International Exhibition, Kelvin Grove Park, Glasgow, on Wednesday, 5th, Thursday, 6th, and Friday, 7th September.

— A CORRESPONDENT writes regarding CARNATION PRIDE OF PENSHURST:—"Can any of your readers tell me the true origin of Mrs.

George Hawtrey, and who gave it its name? Probably the florist of Sidmouth, Devon, could enlighten the Carnation growers in the matter, particularly Mr. F. Bridger, the raiser of the *Pride of Penshurst*."

— We are informed that the first Show of CHRYSANTHEMUMS, FRUIT, AND VEGETABLES AT BOLTON on November the 17th was a decided success from every point of view. The exhibits were good all round, the classes being well represented and the prizes well contested. In class 1, for a group of Chrysanthemums arranged for effect in a circle, the first prize was awarded to Mrs. Haslam (gardener, Mr. J. Hicks); second, John Heywood, Esq.; third, Col. Cross Ormrod. The cut blooms were especially good. The best eighteen (nine incurved and nine Japanese) were from Mrs. Shaw (gardener, Mr. Chas. Jones); a grand collection, the second coming very near to it in merit. One very pleasing feature in the Show were the groups of stove and greenhouse plants arranged by P. Wilkinson, Esq. (gardener, Mr. J. Fountain), and Mrs. Shaw (gardener, Mr. Chas. Jones). The Committee have every reason to be satisfied with the result of their first Show. The Hon. Sec. was Mr. James Hicks, The Gardens, Ravenswood, Heaton, Bolton.

### CYPERUS ALTERNIFOLIUS.

WHERE there are many flower-stands to be kept furnished, especially through the winter, it would be difficult to mention a more useful plant than the above for supplying graceful green foliage. It is easily propagated, grows vigorously, and bears cutting well. It is an old, well-known plant, and is seen to a limited extent in most collections, but is seldom given the prominence to which its useful qualities entitle it. Those, however, who have to supply a quantity of cut flowers and foliage should know how to value a plant of this sort; for with plenty of foliage it is surprising how few flowers are required; indeed, most people of taste would prefer a well-arranged stand of all foliage to one arranged with a number of flowers and scanty foliage. *Cyperus alternifolius* can be grown from seeds sown in well-drained pans or pots, filled to within an inch of the rim with a compost of equal parts of sifted loam, leaf mould, and sand. They can also be propagated by division; every piece of crown, under proper conditions, will form a plant. The quickest and best way, however, of increasing this plant is by rooting the umbrella-like heads, which should be prepared in the following manner:—Cut off the heads with an inch of stem to them; then, drawing them through the hand, cut off the grass to within an inch of the centre, now cut off about half of the grass close to the stem; the cutting is then ready for insertion. Prepare pans or pots as for seeds, and fill them with sand, into which the cuttings should be thickly dibbled, being very careful to bury that part of stem from which the grass was cut, as that is where the roots will be emitted. Give a good watering through a fine rose to settle the sand round the cuttings, then place them in a close, moist, propagating frame, in a temperature between 65° and 75°, and in a fortnight they will be rooted, ready to place into thumb pots. These, if in a suitable temperature, will soon throw up small fine heads, which for decorating small stands are simply invaluable; or, if not wanted for cutting, will be found graceful amongst small flowering plants or for forming an edging round the stages.

If large plants are wanted they must be repotted as required. They are not fastidious as to soil; but, as they require abundance of water, being sub-aquatic, about a sixth part of rocks, bricks, or charcoal, broken about the size of horse beans, should be mixed with the soil, which help to keep it porous and sweet. If they can be planted out, even if it be under stages, so that they get a fair amount of light, they will throw up grand heads on stems 5 feet long, when for decorating large stands they are extremely useful, and especially so when about half expanded. The above cultural remarks apply to all the cultivated varieties of *Cyperus*.—J. H. W.

### CHRYSANTHEMUM NOTES.

#### CHALLENGE CUPS.

PERMIT me to tell Mr. Jameson that I have much more knowledge of the question that recently arose between Mr. Mease and the Committee of the Hull and East Riding Chrysanthemum Society than I have chosen to make use of in the Journal; and Mr. Jameson commits a grave error when he repeatedly charges an opponent with "ignorance of facts" or of failing to "grasp salient points," because such opponent prefers to confine himself to such information as is elicited and given publicly, rather than make use of the abundant private and reliable information at his disposal. A wise man never underrates the knowledge or abilities of his adversary; but Mr. Jameson appears to think that he may do so with impunity. During the past fortnight I have met nearly all the principal Chrysanthemum growers in the north of England, and the unanimity of opinion amongst them on the subject in question is surprising. I leave Mr. Jameson to infer whether that opinion is in favour of himself and his Committee, or of Mr. Mease and myself.

Mr. Jameson's amendment to my suggestion is comparatively worthless, because it probably would not meet 20 per cent. of cases; and it would now utterly fail to serve as a "bait" to Chrysanthemum growers. My suggestion would prevent misunderstandings. The difficulty with Mr. Mease would have been impossible had such words as I suggested

been inserted in the Hull schedule; but Mr. Jameson's would make confusion worse confounded.—J. UDALE, *Elford*.

#### CHRYSANTHEMUM SPORTS.

*Mrs. Norman Davis*.—Several sports have appeared this year amongst the incurved varieties, and those which were noticed last year have improved, this being very notably the case with the golden Princess Teck, Mrs. Norman Davis, which has been aptly compared to a late Mr. Bunn. In the Lilford Road Nurseries, Camberwell, Messrs. Davis and Jones have an extremely fine display of this variety, some hundreds of blooms being expanded, and one side of a long span-roofed house is entirely devoted to the plants. The variety is of robust habit; it is very free flowering, and the blooms are distinguished by their broad florets, depth, and richness of colour. Upon some of the outer florets a slight bronze or pinkish tint is sometimes noticeable, exactly of the same character as seen in the parent Princess Teck. As a decorative plant, and for affording a late supply of flowers, this Chrysanthemum will become a general favourite; for the midseason and late shows it will also prove useful as a front-row bloom.

*Charles Gibbon*.—Last year a sport was observed on the variety Mrs. Norman Davis, I believe in the same establishment—namely, Mr. Mizen's of Mitcham—it was tested carefully; and again this season under Mr. C. Gibson's charge it has proved thoroughly fixed, quite distinct, and an acquisition of decided merit. It is of similar character to the parent, but with rather better-shaped blooms and very broad, substantial florets, of a deep reddish bronze colour—quite a lively tint for sports of that kind, which frequently come rather dull. It is very promising, and has been worthily named in honour of its grower. The Floral Committee of the National Chrysanthemum Society at once awarded a certificate for this variety, and there was some inclination on the part of one or two of the members of the Committee to award an equal recognition to Lady Dorothy, shown by Mr. Buss, as a bronze sport from Hero of Stoke Newington, and which had been previously certificated at Wimbledon. It was, however, finally decided that though there was some slight difference perceptible between the two as shown at Westminster, it was thought that the lighter colour of Lady Dorothy was due to its having been grown in a higher temperature, and that they were too much alike to be certificated separately.

There is now quite a family of sports from Princess Teck, the white Lord Eversley coming nearest to that in character; then the Hero of Stoke Newington, Mrs. Norman Davis, and Charles Gibbon in a regular line of descent, Lady Dorothy coming from Hero of Stoke Newington.

#### AN OLD CHRYSANTHEMUM.

Blooms were recently sent to Westminster of an old variety of Chrysanthemum that has been lost sight of for many years—namely, the Old Tasselled Lilac. I have also been favoured with blooms of this historical curiosity, and its interest is certainly not its only merit. The blooms, it is true, would not do for exhibition in the present day, but they are pretty, graceful, light, and well adapted for arranging in vases. They are about 3½ inches in diameter, with narrow quilled spreading florets of a pale rosy lilac hue, irregularly and shapely cut at the points. The blooms were sent from a Cornish garden, where it is said the variety has been grown for over fifty years. There seems to be no doubt that it is the original variety that was introduced, for I have carefully compared it with the descriptions published early in the present century. Mr. Harman Payne is also of opinion that it is the true variety, and has sent me a letter that he had intended submitting to the Floral Committee, in which he discusses the matter fully.

#### CHRYSANTHEMUMS IN FRANCE.

I am informed that amateurs are giving much more attention to Chrysanthemum culture in France than formerly, and one gentleman—a reader of this Journal, by the way—has formed a collection of 2500 plants. He recently opened his exhibition to the public on the payment of a small sum, and is reported as having obtained no less a sum than £480, which is to be handed over to a charitable institution. This is an idea that might be followed out by many gentlemen not only in France but in Britain. I also learn that a satisfactory exhibition was held at Roubaix, near the borders of Belgium, when a medal was awarded to Mr. Harman Payne for a collection of engravings representing varieties of Chrysanthemums.

#### JUDGING CHRYSANTHEMUMS.

Frequently it is unnecessary to resort to pointing in judging Chrysanthemum blooms, but wherever the competition is close or the prizes of considerable value it is much more satisfactory to do so. I have had several instances of its importance this season, and especially at Twickenham and Colchester, where it would have been very difficult to arrive at a fair decision without the aid of some system. At both these Shows the leading classes were for twelve Japanese and twelve incurved, and the varying merits of such mixed stands require very careful weighing. Thus at Colchester the number of points obtained by the collection from Mr. H. Lister, which won the Corporation challenge prize, was as follows—Incurved 42, Japanese 45—total 87. The second stand from Mr. Pragnall numbered, for incurved 36, for Japanese 39—total 75. The third from Mr. Neville scoring for incurved 38, thus within four points of the first, and Japanese 30—total 68. At Twickenham the contest between Mr. Furze and Mr. Munroe was still closer, the latter winning only by one point in the twenty-four blooms. In such cases as this a method of sub-division must sometimes be adopted, and

Mr. J. Wright has an excellent and reliable system for this purpose. A simple plan was also proposed by Mr. Williamson in this Journal a few years ago, in which by means of marks and points four of the latter equal one of the former. A modification of this, reversing the names and retaining the point as the higher value, to be sub-divided into four points where necessary, would meet every case.

The system of judging proposed by Messrs. Cannell & Sons, Swanley, was tried at the National Show this month, but was not very satisfactory, and owing to some mistake in collecting the votes the first prize was not awarded to the best collection. I understand, however, that this has been subsequently corrected, as on re-examination of the voters' cards it was found that Mr. J. Martin, West Hill House Gardens, Dartford, was entitled to the premier award. The stand of fine blooms shown by Mr. Martin will be well remembered for the grand specimens of Mr. H. Cannell and Mr. C. Orchard it contained, the finest examples of these distinct varieties that have been shown this season. Although it was stated in the schedule that the awards were to be made by the Floral Committee, this does not seem to have been followed out, and as a matter of fact very few of them assisted in the matter.—L. CASTLE.

### REVIEW OF BOOK.

*Manual of Orchidaceous Plants, Part II., Cattleya and Lælia.* By JAMES VEITCH & SONS, Royal Exotic Nursery, King's Road, Chelsea.

CATTELYAS and Lælias have long held a foremost place amongst the most valued Orchids, but they have become especial favourites within the past twenty years. Large numbers have been imported, many handsome novelties have been introduced, and some remarkable hybrids have been raised here that have all assisted in concentrating the attention of orchidists upon these two genera. It is not surprising that they should become popular, for the flowers are amongst the largest and most richly coloured of the whole family. In most cases, too, they are freely produced, and though their culture is a little more expensive than the cool house Orchids wealthy amateurs have found an especial interest in them, and several have formed large collections. Spacious houses have been devoted to these plants, and such structures as that in Mr. W. Lee's garden, Downside, Leatherhead, or Messrs. Veitch's wonderful house at Chelsea annually afford Orchid exhibitions of surpassing beauty. There has consequently been a great demand for information, both cultural and historical, concerning the Cattleyas and their immediate relations and though several excellent works have appeared something of a more exhaustive character was required combining sound practical instruction with scientific accuracy, and sufficient general and historical particulars to give it a popular interest. It is the object of the work under notice to meet this demand, and we will endeavour to show how well it has been accomplished.

The book is uniform in size, with the first part devoted to Odontoglossums, but contains 108 pages, and is profusely illustrated with wood engravings, many of which are printed separately on toned paper. Three excellent maps are also given, indicating the geographical distribution of the two genera in Southern Brazil, Central America, and Mexico with Guatemala, and these constitute an important feature of the work, as they are carefully and clearly drawn, the names of the species being printed in small black type over the respective regions where they are chiefly found. The illustrations include the leading types of each genus, single flowers being mostly shown together with miniature representations of the whole plant in some cases, and more of these might be advantageously given, as single flowers convey but an imperfect idea to those unacquainted with the plant, and the best description that can be penned falls short of an engraving from a popularly instructive point of view. In one case, that of the curious hybrid *Soprocattleya Batemanniana*, an illustration is furnished of the details of the flower in the usual botanical style, and in such instances this is very interesting, as the resemblance to the different parents can be more readily traced. The frontispiece is an engraving of Messrs. J. Veitch & Sons' Cattleya house, which was prepared for this Journal two years ago and was first published page 215, March 12th, 1885. By a strange oversight, however, there is no acknowledgment of the source whence it was obtained, and this is the more remarkable since the authors are usually so generous in such matters.

To the genera *Cattleya* and *Lælia* the greater portion of the book is devoted, but the closely related *Læliopsis*, *Tetramiera* (*Leptotes*), *Schomburgkia*, and *Sophranitis*, which comprise only a few species, are also described. The generic characters are those of the Hooker and Bentham's "Genera Plantarum" translated into English and condensed. Then in the case of *Cattleyas* follows an interesting review of the geographical distribution, and three regions are mentioned as containing the principal species—namely, "1. Mexico and Guatemala in the extreme north of the region sketched above. 2. In the northern part of the South American Continent, that extends from the western Cordillera of New Granada to British Guiana; and 3. The maritime provinces of southern Brazil." The climatal characteristics of these regions are concisely sketched, and supply valuable information for cultivators. The cultural details are clear and full.

The species and varieties of *Cattleya* are next treated, the *C. labiata* group comprising *C. Dowiana*, *C. Mossia*, *C. Mendeli*, *C. Triana*, &c., which are botanically referable to *C. labiata*, though usually regarded in gardens as distinct species. By the courtesy of the authors we are enabled to give the figure of *Cattleya labiata* var. *Dowiana* (fig. 57), which is well known as one of the most handsome of the genus. Under these varieties are arranged numerous sub-varieties, but only the most

distinct have been selected. The same system of nomenclature is adopted as with the *Odontoglossums*, but it seems inconsistent to give some the ordinary botanical names, and others the English equivalent. Thus under *C. labiata* var. *Mendeli* we have sub-var. "bella" as an example of the former, and "Blunt's," "James'," "Mr. Lee's," and "Mrs. Morgan's" as instances of the latter, and this occurs throughout even where the rejected names, like *Reineckiana* and *Wagneri* (under *C. Mossia*), have been recorded in botanical works by scientific authorities.

After the *C. labiata* group has been fully discussed the remaining species are taken in alphabetical order, commencing with *C. Aeklandia*, and ending with *C. Walkeriana*. *Lælia* is treated in a similar manner, descriptive lists of hybrid *Cattleyas* and *Lælias* following together with *Soprocattleya Batemanniana*, the hybrid between *Sophranitis grandiflora* and *Cattleya intermedia*, and which was first referred to *Lælia*,



Fig. 56.—*Soprocattleya Batemanniana*.

but has since been elevated into a new genus, the name indicating the two parents, and the method is a very good one in the case of bigeneric hybrids where it can be done without producing a eumbrous compound. It has been previously adopted with the hybrid between *Philesia* and *Lapageria*, which was converted into *Philageria*. For the woodcut portraying the *Soprocattleya* we are also indebted to Messrs. Veitch and Sons.

The literary character of the work is admirable. There are a few literal errors, but they are of little importance, and the book has evidently been carefully written and revised. We could have wished, however, that the index had been somewhat more comprehensive, as some of the varieties are not included, and many synonyms are omitted. Still it constitutes a most welcome addition to Orchid literature, thoroughly reliable, and just what we should expect from the great Orchid experience of the firm.

### CHRYSANTHEMUM SHOWS.

FAVERSHAM AND DISTRICT.—NOVEMBER 16TH AND 17TH.

THE first annual Show of this Society was held in the Drill Hall, Faversham, on the 16th and 17th inst. The Association was only formed twelve months ago, and a great deal of its success is due to the energetic Hon. Secretary, Mr. C. Sudolph, who is assisted by an able Committee. The



Association has received a large amount of local support and distinguished patronage, and their first Chrysanthemum and Fruit Exhibition was a decided success. The entries were divided into three classes—professional gardeners, amateurs, and cottagers—all of which were well represented. Plants were staged in the centre of the hall and the cut blooms ranged at the sides, whilst the ends were occupied by exhibits by local nurserymen. In the cut blooms the most attractive class was the open twenty-four—twelve incurved and twelve Japanese. The competition was very keen, and some grand blooms were exhibited, Mr. W. Ray, nurseryman, of Green Street, winning the first prize; Mr. G. Ray, nurseryman, Green Street, second; Mr. Goodham, gardener to Mr. Thomas, Harold Nursery, Sittingbourne third; and fourth, Mr. Geo. S. Addison, an amateur, of Thornton Heath.

In the class for twelve incurved Mr. Dodswell, gardener to R. Lake,

which secured him premier honours. Mr. Taylor took second prize, and Mr. Weller third. Mr. Finlay was again to the front with a fine collection of dessert Apples, including Lord Deby, Blenheim Pippin, Wellington, &c.

In the cottagers' classes some good cut blooms of both incurved and Japanese Chrysanthemums were staged, the principal prizewinners being Messrs. Percy Sherwood, T. Atkins, and T. Terry, but their strong point lay in the vegetable department. Mr. Fred. T. Hart, of Ospring Road Nursery, Faversham, had a very attractive stand, consisting of foliage, flowering, and berried plants, cut blooms of Chrysanthemum, amongst which were MM. Thibaut et Keteleer, Edouard Audiguier, La Triomphante, Roi de Japonais, François Debergne, and the best of all Pompons, Mlle. Elise Dordar. His collection of fruit included good dishes of Golden Noble, Blenheim Pippin, &c.

Upwards of a thousand persons visited the Exhibition on Thursday,

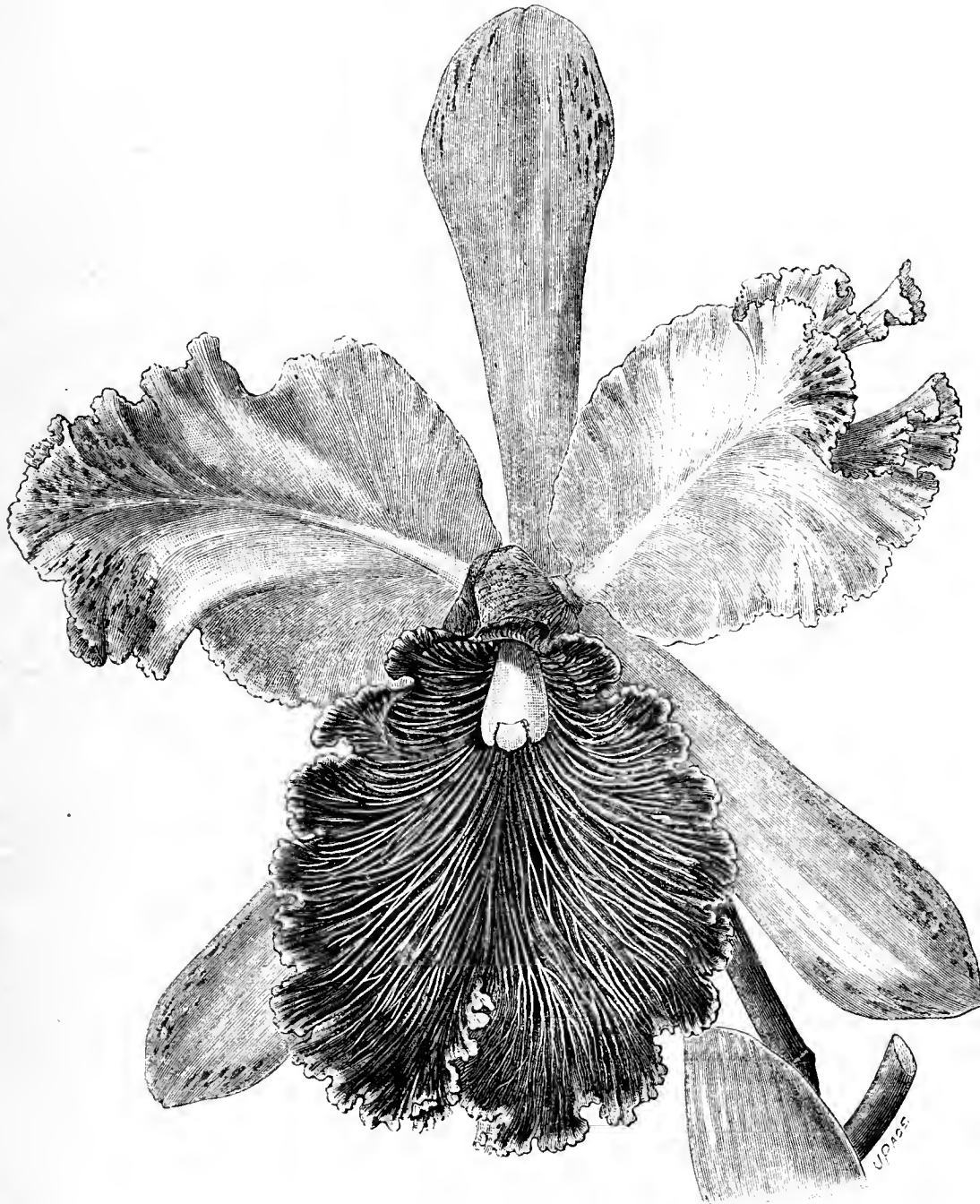

FIG. 57.—CATTLEYA LABIATA VAR. DOWIANA.

Esq., Newland, was first with fine blooms of Lord Alcester, Emily Dale, Queen of England, Prince Alfred, and Empress of India, the last named being a grand bloom. Mr. Taylor took second prize, and Mr. Ratcliff third. Mr. Dodswell was also first in the class for twelve Japanese, distinct, with good blooms of Belle Paule, Thunberg, Criterion, Grandiflorum, and Madame C. Audiguier. Mr. Taylor was again second, and Mr. Louth third. Reflexed blooms were well shown by Mr. Taylor and Mr. Ratcliff. In the latter's stand were good blooms of Cullingfordi and White Christine.

In the amateur classes Mr. C. Stidolph's exhibits were far and away the best, and he succeeded in taking first prizes in the classes for six incurved, six reflexed, and six Japanese, followed by Mr. H. Dan, Mr. J. W. Cook, and Mr. G. R. Lydon. Amongst the most prominent blooms in the winning Japanese stands were Grandiflorum, Elaine, Triomphe de la rue des Châlets; and in the incurved, Lord Wolseley, Lord Alcester, and Empress of India.

Fruit and vegetables were exceedingly well shown, and one of the features of the Show was the superb display of Grapes. Mr. Finlay, of Lees Court, exhibited three bunches of Alicante of extraordinary size,

which of itself speaks for the success of the undertaking, and the executive are to be congratulated upon their first venture.

#### ST. ALBANS AND DISTRICT.

A CAPITAL little Show was held by the above Society in the Town Hall Assembly Rooms, St. Albans, on the 22nd inst. The prizes were small, but in most cases were well contested, particularly in the open classes for cut blooms. In the class for twelve Japanese it was a close race between G. Lake, Esq., Bushy House, Watford (gardener, Mr. Rumbalds), and the Rev. K. F. Gibbs, Aldenham Rectory, Aldenham (gardener, Mr. Lazzell), the former gentleman being placed first with a very even stand of well-coloured blooms, the most noticeable being Belle Paule, Grandiflorum, Fair Maid of Guernsey, and Comte de Germiny, the latter being very fine. — Hegan, Esq., Bucknalls, Watford (gardener, Mr. Sharpe) was a good third. In the incurved section the Rev. Gibbs was well to the fore, showing good blooms of Golden Empress, Empress of India, Golden Queen, Eve, and Lord Wolseley; second, H. Gilliat, Esq., Cecil Lodge, Abbots Langley (gardener, Mr. Stevens); third, G. Lake, Esq. Wreaths and bouquets were well shown.

There was a good competition in the class provided for six plants, any variety, untrained and not disbudded; Mr. Brown, Belmont Villas, St. Albans, was a good first. In the classes for Japanese and incurved, six plants in each class, the principal prizetakers were Miss Debenham, Ivy House, St. Albans, and Mr. Brown. G. H. Martin, Esq., The Bank, St. Albans, had the best specimen plant in the Show.

There were no prizes offered for groups, but these were well shown by honorary exhibitors, the most noticeable being those sent by the President, J. Blundell Maple, Esq., Childwickbury (gardener, Mr. Nutting), Lord Grimthorpe, Batchwood (gardener, Mr. Whitelaw), J. S. Hill, Esq., Hawkswick (gardener, Mr. Emptage), and J. Rokeby Price, Esq., Clementhorpe (gardener, Mr. Shaw). In the latter gentleman's group were some fine Calanthes. The exhibits which probably attracted the greatest attention were the grand specimens of trained plants from H. Hucks Gibbs, Esq., Aldenham House, Elstree (gardener, Mr. Beckett). Mr. Beckett has given many proofs of his skill in the culture of the Chrysanthemum, but it is doubtful that he has ever produced finer plants than those he has staged this season. The varieties were Prince of Wales, Lord Wolseley, Maiden's Blush, Mdle. Lacroix, M. H. Jacotot, Prince Alfred, John Salter, Mrs. G. Glenn, Mrs. G. Rundle. The first five were very fine. Mr. Beckett also staged superb cut blooms; these were very much admired, as were the fine collections of fruit and vegetables exhibited by him.

A fine collection of cut blooms came from R. Henty, Esq., Langley House, Abbots Langley (gardener, Mr. Brown), also from H. Gilliat, Esq. Messrs. Lane & Son exhibited a fine lot of Apples. Mr. Tilbury, gardener to Mrs. Drake Garrard, Lamer Park, Wheathampstead, had a good display of fruit and cut flowers. Mr. Chapman, Hatfield, exhibited some choice specimens of rustic pottery, which were much admired.

#### BUCKINGHAM.—NOVEMBER 22ND.

The first annual Chrysanthemum Show was opened at the Town Hall, Buckingham, on Tuesday, 22nd inst., by the Mayor (G. H. Harrison, Esq.), and proved highly successful, and the Committee are to be congratulated. Special praise is due to the worthy Secretary, Mr. A. Walford, for the hearty manner in which he carried out the onerous duties of secretaryship, and to the Stewards, Counsellor J. Marshall and Mr. C. Tailby, who worked hard in the arrangement of the Show. The hall presented a picturesque appearance. The centre of the building was occupied with three central groups; around the sides were groups 6 by 6 feet, specimen plants, Primulas, cut blooms, &c. In the adjoining small hall was arranged fruit, vegetables, and cottagers' productions, &c. The majority of exhibits were of excellent quality, and were much admired by a large number of visitors. In the open class A for the best central group, Mr. W. A. Walter, gardener to Alfred B. Loder, Esq., Lillingstone House, near Buckingham, took first honours with a well flowered group; Mr. T. Holton, Buckingham, second, with a neat dwarf group; Mr. Saunders, gardener to H. Small, Esq., Claydon Camp, third. For the best six natural trained plants there were seven entries, the first prize was secured by G. Bennett, Esq., with good well flowered plants; Dr. Duke, second; and Mr. W. Richardson third. In the open class for cut blooms, eighteen varieties of incurved (distinct), Mr. W. A. Walter took the lead with a good even and fresh stand; notably good were Princess of Wales, Hero of Stoke Newington, Princess Teck, Mr. Bunn, Jardin des Plantes, Barbara, and Cherub; Mr. Tipler, gardener to M. S. Gulliver, Esq., Aylesbury, following second with a good stand, in which Empress of India and Lord Alcester were particularly good. For eighteen varieties Japanese, Mr. Walter was again a good first with fine blooms of Baronne de Prailly, M. g. Merrilies, Boule d'Or, Triomphe de la rue des Châlets, Fair Maid, and Criterion; Mr. Tipler following second. For twelve Chrysanthemums, four reflexed, four Anemone, and four Pompons, Mr. Walter was first, and Mr. Tipler second.

In class B, for gardeners and market growers within ten miles of Buckingham, Mr. W. Boulton secured the first honours for a beautiful group 6 by 6 feet, which was much admired. Mr. C. Saunders was placed second with a creditable exhibit. For six Primulas Mr. G. Freeman, gardener to Mrs. Pilgrim, Akeley Wood, gained the first prize with good plants. Mr. C. Chatwell, gardener to Rev. A. J. Mees-Hogg, Mixbury, second, and Mr. J. Price, gardener to H. Gosling, Esq., Westbury, third. For one specimen foliage plant Mr. G. Freeman was first with a fine Dicksonia; Mr. Walter second with *Lantana borbonica*; and Mr. Price third. In the cut blooms Mr. Walter again carried all before him; in fact, in this class his blooms were far ahead of all the other competing stands. For twelve varieties incurved, distinct, Mr. Walter was first, Mr. Freeman second, and Mr. Saunders third. For twelve Japanese, distinct, in the same order again, Mr. Walter first, &c. For six varieties Japanese Mr. Walter, Mr. Freeman, and Mr. W. Sturdy, gardener to Mrs. Peel, Thornton Hall, were the winners. For six incurved blooms Mr. Walter was first, Mr. Freeman second, and Mr. C. Chatwell third. For bouquets (special prize given by Mr. Walter), first, Mr. Chatwell; second, Mr. J. Price; third, Miss Roberts, Tile House. Floral centrepiece, first, Mr. C. Tailby, Buckingham; second, Mr. W. Boulton, gardener to A. J. Roberts, Esq., Tile House, Buckingham.

Two bunches of Grapes were shown by five exhibitors.—First, Mr. J. Price with Lady Downe's; second, Mr. Walter with Black Hamburgh; third, Mr. W. Boulton with Muscat of Alexandria. Four dishes of Apples (two dessert and two culinary) brought several entries of fine fruit. First, Mr. Walter; second, Mr. Freeman; third, Mr. C. Tailby. For two dishes of Pears (one dessert, one culinary), first, Mr. Walter; second, Mr. Freeman; third, Mr. W. Sturdy. Vegetables were very fine. For the best collection the first prize was awarded to Mr. Freeman, the second Mr. W. Boulton, and the third to Mr. Chatwell. Following this there were several well filled amateurs' classes, likewise cottagers', all of which included some excellent productions.

#### BEVERLEY.—NOVEMBER 23RD.

For the last five years very successful exhibitions of the queen of autumn flowers has been held in this historic capital of the East Riding. The thanks of its inhabitants and neighbourhood generally have been well deserved by the Gardeners' Mutual Improvement Society, under whose auspices the Show was first inaugurated and is still carried on. The Show this year was a very great advance on its predecessors both in quantity and quality, many of the exhibits being fully equal to, and in several instances superior to those seen at shows of greater pretensions.

In the open class for groups Mr. G. Cottam, nurseryman, Cottingham, Hull, was an excellent first with a well grown and tastefully arranged collection containing plants of Chrysanthemums, Palms, Crotons, Ericas, Ferns, &c. Mr. J. Smith, Norwood Nursery, Beverley, was a very close second. In the open class for twenty-four cut blooms (twelve Japanese and twelve incurved) Mr. Leadbetter, gardener to A. Wilson, Esq., Tranby Croft, was well to the front with excellent specimens of the very best varieties; J. Fisher, Esq., of Willerby House, Hull, being second with flowers but very little inferior to his more successful opponent. The same exhibitors were similarly placed in the class for twelve distinct varieties. In the class open to all but dealers, J. A. Hudson, Esq., Longcroft, Beverley, won easily with splendid flowers of large size and excellent finish; the same may be said of two other stands exhibited by the same gentleman. Col. Clitheroe, Hotham Hall, Brough, contributed several very good stands of fine flowers. In the same classes Col. Hodgson, Beverley, and Mr. G. Cottam were amongst the successful exhibitors. In the plant department, which contained many specimens of exceptional merit, some of the plants being fully 4 feet in diameter, and literally smothered with flowers, Mrs. Crust, Beverley, and Mr. F. Smith had things pretty much their own way. Bouquets, buttonholes, and wreaths were fully up to the mark. The first prize bouquet and wreath, composed of Chrysanthemums, were very beautiful. Large and well finished bunches of Muscat of Alexandria and Alicante were shown. H. Stowton, Esq., Holme Hall, and W. F. Wrangham, Esq., Hotham House, were very successful with fruit of large size and good quality.

One great feature in the Show was the splendid collection of over 150 dishes of Apples exhibited by Mr. Geo. Swales, nurseryman, Beverley. This collection was very tastefully arranged, and contained amongst others perfect specimens of Blenheim Pippin, Nelson's Glory, Lady Henniker, Tower of Glamis, Ribston Pippin, Cox's Orange Pippin, Alfriston, &c. This was without the exhibition the best collection of Apples grown in this neighbourhood that has been exhibited here for many years.

#### BRISTOL.—NOVEMBER 23RD AND 24TH.

The date of holding this important Show was unusually late, but this instead of injuriously affecting the number of entries seemed to have a contrary effect. At any rate, it was the best all-round display yet brought together by this old established Society, and its merits were fully appreciated by a large number of visitors. The Drill Hall in which it was held is a very commodious structure, and quite capable of holding all the numerous exhibits without unduly encroaching on the space required for the comfort of visitors. Mr. W. H. Bannister is the Secretary of the Society for the time being, and we should think would make a most excellent permanent official. With him are associated a Committee of practical gardeners, who do their best to make the Show a great success in every way.

PLANTS.—Trained specimens were certainly not up to their usual excellence, several noted growers having of recent years discontinued their culture. For six plants of large flowering varieties Mr. J. Lee, gardener to T. M. Miller, Esq., was easily first, taking a silver cup; Mr. F. Perry, gardener to H. Cruger Miles, Esq., being second, and Mr. T. Gibson third. The best three specimens were staged by Mr. M. Cole, gardener to S. Tredwell, Esq., Bath, a capitally flowered Prince Alfred in this lot being specially commended as being the best trained plant in the Show. Mr. F. Perry was again second, and Mr. J. Lee third, both staging creditably flowered plants. Mr. W. Butter was first for four Pompons and Mr. Gibson second. The best three standard trained Chrysanthemums were shown by Mr. M. Cole, Mr. A. Potter, gardener to R. A. Ross, Esq., and Mr. W. H. Bannister, gardener to H. St. Vincent-Ames, Esq., being respectively second and third. In the class for a single specimen of Japanese Chrysanthemum Mr. A. Porter was first with an immense flatly trained and profusely flowered Bouquet Fait. Mr. J. Lee was second and Mr. Gibson third. The groups of naturally grown Chrysanthemums were fairly good, but were more remarkable for the quantity rather than the quality of the blooms. Mr. F. Perry was well first, Mr. T. Marshall, gardener to J. Dole, Esq., being a creditable second, and W. Taylor, gardener to Dr. S. P. Budd, Bath, third. These groups of Chrysanthemums were arranged down one side of the Hall and alternated with grand hanks of fine-foliaged plants, the latter always being well shown at Bristol. Mr. W. Pye, gardener to J. Derham, Esq., was first for six fine-foliaged plants, which included a fine *Cycas revoluta*, a good *Areca sapida*, and well coloured Crotons. Captain Bellfield was a very close second, and Mr. W. Dobson third. With four specimens Mr. E. Miller, gardener to F. Tagart, Esq., was first, S. Budgett, Esq., second, and Mr. F. Perry third, all having well grown choice plants. Several good groups of six Ferns were staged, and with these Mr. E. Miller was first, Mr. W. H. Bannister second, and Captain Bellfield third. Bouvardias were well shown by Messrs. J. H. Vallance, gardener to J. C. Wall, Esq., W. Rye, and G. Shelton, gardener to W. K. Waite, Esq.; Primulas by Messrs. H. Lewis, gardener to Boddam Castle, Esq., M. Cole, and B. Hardwell; herried plants, by Messrs. J. Lee, J. Ayres, and W. Lintern, gardener to W. Butter, Esq.; Poinsettias by Messrs. M. Cole, W. Coates, and T. Loosemore, gardener to W. Cooper, Esq.; and table plants by Messrs. J. Ayres, gardener to T. Gibson, Esq.; W. H. Bannister, and Captain Bellfield, the prizes being awarded in the order the names are given in each instance. Two excellent groups of miscellaneous plants were arranged, Mr. W. Rye was rightly awarded the first prize, his arrangement being light and tasteful, and comprised many well grown Palms, Crotons, Dracenas, Ferns, Calanthes, *Cypripediums*, *Zygopetalums*, and other Orchids. Mr. F. Perry had a very good bank, and took the second prize.

CUT BLOOMS.—There were more numerous and much superior to what has previously been shown here, the stands from Taunton largely contributing to this improvement. Five growers competed with twenty-four large flowering varieties, Mr. C. Lucas, gardener to J. Marshall, Esq., Taunton, being well first; Mr. G. Runnacles, Sherborne, second; and Mr. T. Hobbs, Bristol, a good third. Mr. Lucas, in addition to the first prize, was also awarded the silver medal of the National Chrysanthemum Society for the best stand of twenty-four blooms in the Show, and also a certificate for the best single bloom, this being accorded to a wonderful fine Hero of Stoke Newington placed in the back row, and equalling the Lord Alcester in size and finish. He also had fine blooms of Empress of India, Bronze Queen of England, Golden Empress, Princess Alice, Lord Wolseley, Jeanne



d'Arc, Cberub, Mr. Howe, Emily Dale, Barbara, Blush Queen of England, Lord Wolssley, and Princess of Teck. With twelve distinct varieties Mr. W. Thomas, gardener to W. Marshall, Esq., Taunton, took the lead, having fine fresh blooms of Empress of India, Bronze Queen of England, Golden Empress, Lord Alcester, Alfred Salter, Prince Alfred, Mr. Howe, Jardin des Plantes, Barbara, and Jeanne d'Arc. Mr. J. Baylis was a good second, and Mr. Runnacles third. Mr. C. Lucas was again first for six blooms, these being very fine, Mr. J. Aplin, gardener to W. M. Baker, Esq., being a good second, and Mr. W. Carpenter, gardener to A. Cole, Esq., third. With twenty-four Japanese varieties Mr. W. Thomas was rightly placed first, included in his stands being very fine fresh blooms of Madame C. Audiguier, Comtesse de Beauregard, Meg Merrilies, Belle Paula, Yellow Dragon, J. Délaux, Marguerite Marrouch, Yellow Dragon, Gloriosum, Triomphe de la rue des Châlets, Peter the Great, and Soliel Levant. Mr. Runnacles was only a very few points behind, his best being Fair Maid of Guernsey, Red Gauntlet, Thunberg, and Madame J. Laing. Mr. E. Miller was a creditable third. The best twelve varieties were staged by Mr. C. Lucas, who had capital blooms of Carew Underwood, Fair Maid of Guernsey, Meg Merrilies, Comtesse de Beauregard, L'Adorable, The Daimio, Duchess of Albany, Baronne de Prailly, Fimhriatum, and Mrs. J. Bright. Mr. Runnacles was second, and Mr. W. J. Cole third. A few good stands of Anemone-flowered varieties were shown. Mr. W. Thomas was easily first, his best being Mlle. Cabrol, Fahias de Mediana, Souvenir d'Ardene, Fleur de Marie, Madame Berthe Pigny, Lady Margaret, and Gluck. Mr. W. J. Cole was second, and Mr. T. Hobbs third.

There were two classes for hand bouquets, and several huge, though well made examples, were shown. The sooner these are limited in size the better. Mr. C. Winstone, Clifton, had a first and third; Messrs. Perkins and Sons, Coventry, one second; Mrs. Dyer, Taunton, one first, and Mr. M. Hookings one second and one third prize. Mr. Hookings was also most successful with vases of choice flowers and hardy foliage and berries; Messrs. W. Dobson, E. T. Hill, J. C. Aiken, and C. Winstone also showing well in these classes.

FRUIT AND VEGETABLES.—A capital lot of fruit was shown, the competition being very keen in nearly every class. The best collection of six dishes was staged by Mr. W. Pratt, gardener to the Marquis of Bath, Longleat, who had beautifully finished Muscat of Alexandria and good Alicante Grapes, Golden Queen Melon, Medlars, Apples and Pears. Mr. W. Iggulden, gardener to the Earl of Cork, Frome, was a creditable second, and Mr. E. Miller a close third. With Black Hamburgh Grapes Mr. T. Painter was first, Mr. J. H. Virgo second, and Mr. W. Loosemore third, all staging rather small bunches. Mr. Pratt had superb Muscat of Alexandria, and was first, being followed by Mr. J. F. Wilkinson, who also had very good bunches, the third prize going to Mr. G. W. Coates, gardener to Mrs. Miller. Alicante was not so largely shown as usual. Mr. Pratt was first with good bunches, the berries being large and fairly well finished; Mr. W. Iggulden was second, while Mr. W. Rye also staged well. The best finished Lady Downe's were shown by Mr. Iggulden, Mr. Pratt being second, and Mr. G. W. Coates third; both have large bunches with fine berries. Mr. Iggulden was also first for two good bunches of Gros Colman, Messrs. G. W. Coates and W. J. Cole being respectively second and third. Mr. W. G. Pragnell, Sherborne Castle, had very well coloured bunches of Mrs. Pince, and was first; Mr. J. Atwell, gardener to J. B. Brain, Esq., being second, and Mr. Coates third. In the class for any other black sort, Mr. Iggulden was first with Gros Guillaume, and Mr. E. T. Hill second with Madresfield Court, while in a corresponding class for any white sort Mr. Atwell was first with well kept Foster's Seedling, and Mr. Rye second with Trebbiano. A fine lot of Pears were staged. Mr. W. H. Bannister was first for six dishes, these consisting of good Doyenné de Boussoch, Easter Beurré, Marie Louise, Duchesse d'Angoulême, Pitmaston Duchess, and Conseiller de Cour. Mr. T. Painter was second, and Mr. W. Iggulden third. Mr. Jones had the best four sorts, Mr. W. Rye being a good second, and Mr. W. H. Bannister third. Fine and very delicious fruit of Winter Nelis gained Mr. Virgo the first prize in the class for a single dish, Mr. Rye following with good Doyenné du Comice.

Apples were remarkably well represented, no less than 700 dishes having been entered. Mr. W. G. Pragnell was awarded the first prize for six dishes of dessert varieties, these consisting of clean beautifully coloured King of the Pippins, Cox's Orange Pippin, Lord Burghley, Scarlet Nonpareil, Adams' Pearmain, and Ribston Pippin. Mr. Bannister was a good second, and Mr. J. Virgo third. The best four dishes, consisting of Blenheim Pippin, Ribston Pippin, Cox's Orange Pippin, and King of the Pippins were staged by Mr. J. H. Vallance, Mr. Virgo being second, and Mr. Bannister third. The first prize for a single dish was awarded to Mr. E. Hall for Ribston Pippin, Mr. Iggulden following with Cox's Orange Pippin. Mr. Pragnell was first for six culinary sorts, Mr. Aplin being second, and Mr. G. Garraway third. Mr. Aplin was first for a single dish, having fine Blenheim Pippin, Mr. Runnacles being second, and Mr. E. Hall third. Knightian silver and bronze medals of the Royal Horticultural Society were offered for the most complete collection of Apples. The former was awarded to Mr. J. Watkins, Hereford, who had at least 150 dishes, all the best new and old sorts in cultivation being included, and it was altogether a noteworthy exhibit. Mr. J. Scott, The Royal Nurseries, Merriott, staged 140 dishes, among these being fine heavy samples of Sandringham, Gascoigne Scarlet, Lane's Prince Albert, Claygate Pearmain, Cornish Gilliflower, Costard, Mère de Ménage, Cox's Pomona, Transparent de Croncels, Baumann's Reinette, Gloria Mundi, and Emperor Alexander, and secured the bronze medal. Pine Apples were the last in the prize list. Mr. Jones, Worcester, was first for a very fine fruit of Smooth Cayenne, the second prize going to Mr. H. Morris, gardener to A. P. Vivian, Esq., who had a very good Charlotte Rothschild, and Mr. Pragnell was third.

There were two classes for vegetables. Mr. W. G. Pragnell was well first for ten varieties, these consisting of Wright's Grove White Celery, Hackwood Park Tomatoes, Ronsam Park Onions, Aigburth Sprouts, Scotch Champion Potatoes, Autumn Giant Cauliflowers, Lion Leeks, Tender and True Cucumber, and Pragnell's Exhibition Beet, all shown in the well-known Sherborne Castle style. Mr. Bannister had a clean good lot, and was second, the third prize going to Mr. J. Aplin.

SPECIAL PRIZES.—Messrs. Wood & Son, Wood Green, London, offered a medal and other prizes for the best specimen plant of white Chrysanthemum fed with Wood & Sons' liquid manure powder, and five competed for

these. Mr. J. Lee was placed first for a fairly good trained plant of Mrs. Rundle, Mr. F. Perry being second with Fair Maid of Guernsey, and Mr. A. Porter third for a standard of Empress of India, the fine foliage and blooms of the latter being specially noteworthy. A special prize was also awarded to Mr. W. H. Bannister for his beautiful white Mignonette. Messrs. Sutton & Sons offered prizes for six varieties of vegetables, and for which five competed, all staging very creditably. Mr. Bannister was first, Mr. E. T. Hill second, and Mr. Dole third.

NON-COMPETITIVE EXHIBITS.—These were more numerous than usual, and were of a decidedly attractive character. Messrs. Parker and Sons, St. Michaels Hill Nursery, lent some capital fine-foliaged plants, which were effectively grouped about the hall. Messrs. Garaway & Co., Durham Downs Nursery, Clifton, staged a fine lot of Chrysanthemums, about 150 blooms being shown, these comprising an admirable selection of new and old sorts. Messrs. Sutton & Sons, Reading, sent a remarkably fine lot of Cyclamens. They were stated to be only twelve months old, were principally in 7-inch pots, and being far superior to anything of the sort previously seen in the neighbourhood of Bristol, naturally attracted much critical attention. A great variety of colours were shown, the flowers and foliage alike being good. Certificates of merit were awarded to Butterfly, a charming white, and Vulcan, a novelty recently named, the colour of this being a rich ruby red. Messrs. Sutton & Sons also had a capital assortment of Potatoes, all their popular novelties being well represented. Messrs. Wood & Son had a stand of all their specialties in the way of manures and insecticides. Messrs. Wood of Eastville, Bristol, exhibited boiler and heating apparatus in working order, and Messrs. Crispin & Son, engineers, Bristol, also had somewhat similar exhibits.

BEDFORD.—NOVEMBER 23RD AND 24TH.

THE first Show of this newly constituted Society, inaugurated on Wednesday, the 23rd inst., and continued on the following day, proved, notwithstanding numerous prognostications of failure on account of the lateness of the fixture, an initial success. The Exhibition was held in the commodious Bedford Exchange Hall, in connection with a show of pigeons, rabbits and cage birds. In addition to liberal inducements held out to Chrysanthemum growers, prizes were offered in the schedule for fruit and vegetables, Primulas, &c. There was a good and extensive display of pot plants arranged in groups round the room, and these, with cut blooms and fruit and vegetables on tables in the centre, interspersed with Primulas and some choice Orchids and Ferns not for competition, from Mr. Thody of Bedford, formed a very effective display. Competition in most of the classes was strong, and the financial results such as will probably induce the Committee next season to renew and extend their efforts, especially in the direction of open classes. The arrangements were well carried out, and but for the regrettable temporary illness of the energetic Honorary Secretary, Mr. J. Sanders Clarke, which affected a few minor details only, reflected credit on the Committee, and fully gratified the expectations of the exhibitors and promoters. It is evident that an increasing taste for and interest in the queen of autumn flowers has been fostered in the locality by the Exhibition just past, and greater results may be prospected from a repetition.

In the class open to all England for the best group of Chrysanthemums with foliage plants, space not to exceed 50 square feet, quality and general effect to be the leading feature, the first prize was awarded to Mr. J. C. Sheppard, Nurseries, Bedford, for a densely packed but rich collection of varieties, in which were contained some of the best novelties of 1886-7, including Edouard Audiguier, Madame Berthe Rendatler, W. Holmes, Florence Ring, Charlotte de Montcabrier, Mrs. Clarke, Cullingfordi, Mlle. Marie Clos, &c., besides many of the finer old sorts in good form. Mrs. E. Horton, Bedford, was placed second with a small but well-foliaged collection, containing also some good varieties, and Mr. George Robinson, gardener to F. Howard, Esq., Abbey Close, Bedford, third, with larger and well-flowered specimens well interspersed with Ferns and foliage plants.

For six large flowering Chrysanthemums, incurved, distinct varieties, not dwarfed train, in the class open to amateurs and gentlemen's gardeners in the county, the first prize was, after careful consideration, awarded by the Judges to a collection from P. Howard, Esq.; second to Mr. G. Vyne, gardener to C. Franklin, Esq., Bedford. A fine collection from Mr. J. Hermann, gardener to Griffith Jones, Esq., Goldington Bury, being disqualified as not answering the requirements of the schedule, being fully grown dwarf-trained specimens, and an extra prize was accordingly awarded him. For six Japanese, the prizes were awarded in the same order, Mr. Hermann, who, if his plants had been in compliance would have been first, being again awarded a special prize. In the class for four Pompons Mr. Hermann was placed first. In the same division were prizes for groups of Chrysanthemums 30 square feet allowed. The first prize here fell to Mr. Hermann, who had in his collection good examples of Valle d'Andorre, L'Incomparable, F. A. Davis, Isabella Bott, Referee (reflexed red), L'Adorable, M. Lemoine, and M. Leon Bural. Mr. G. Vyne was placed second; and Mr. R. Day, gardener to Joshua Hawkins, Esq., Bedford, third.

In the open class for cut blooms, twenty-four distinct large flowering, Mr. J. Ripling, gardener to Earl Lytton, Knibworth, Herts, was first with a stand containing fine blooms of Lord Alcester, Golden Empress, Empress of India, Jardin des Plantes, Mrs. Shipman, Queen of England, and Hero of Stoke Newington; second, Mr. W. Stevens, Great Houghton, Northampton, with smaller blooms, Barbara, Mr. Bunn, and Bronze Queen being noticeable in his lot; but the interest of all admirers of cut blooms seemed to centre in the open class for twenty-four distinct Japanese. Here Mr. Ripling was deservedly first with a splendid and very regular and well-arranged stand of large and fresh blooms, the colours being bright and striking. The varieties as follows:—M. Ardene, Bend Or, Fair Maid of Guernsey (very fine white), Madame C. Audiguier (very fine), Thunberg, Duchess of Albany (bronze), Album plenum, Japonais, Criterion, M. Burnet, Triomphe de la rue des Châlets, Jeanne Délaux, Belle Paule, Val d'Andorre, (very rich), Comtesse de Beauregard, Grandiflora, Marguerite Marrouch, Cendrillon, Striatum, Roseum superbum, L'Adorable, Meg Merrilies. Mr. Stevens had also a very fine stand as second, Jeanne Délaux, Dr. Macary, Grandiflorum, Mr. Jno. Laing, L'Adorable, Boule d'Or, M. Burnet, Roseum superbum, and Golden Dragon being his best flowers. Mr. H. Cook, gardener to Colonel Unwin, Asphey Guise, Beds, also staged very creditably for third place.



Formine varieties in the open class, not Japanese or incurved, Mr. Ripling was first, having very fine blooms of Fabian de Mediana, King of Crimson, Georges Sand, and Lady Margaret in his stand; Mr. Stevens second. For twelve large flowering incurved blooms, distinct, open to all amateurs, Mr. W. G. F. Clarke, Hitchin, came first, having Lord Alcester, Guernsey Nugget, and Empress of India good; Mr. Stevens was second here and first for twelve Japanese in the same division, Jeanne Delaux, Le Sceptre Toulousain, Jupiter, Duchess of Albany, Elaine, Comte de Germiny, and L'Adorable being conspicuous flowers in his winning stand. In the class for twelve Japanese, open only to amateurs and gardeners of the county, Mr. J. Hermann took the lead, having striking blooms of M. Lemoine, Comte de Germiny, Soleil Levant, Val d'Andorre, Madame Audiguier, Chinaman, and Ethel; B. Seebohm, Esq., Bedford, being placed second. For twelve incurved in the same division Mr. H. Garratt, gardener to R. C. Alston, Esq., Harrold Hall, Beds, was first. Mr. Garratt was also first for a very striking stand of six Japanese in the same division with J. Delaux, Meg Merrilies, Madame C. Audignier, Soleil Levant, Album plenum, and Baronne de Prailly, all very fine. Mr. Garratt was also first for twelve and six large flowering incurved blooms in the same division. Mr. W. Etherington of Swanscombe, Kent, also sent several stands of good blooms not for competition. In the class for six blooms of large flowered incurved varieties, open to amateurs only of the county, Mr. H. Sell, Luton, was first, and six Japanese in the same division Mr. F. H. Brown, Aspley Guise, led.

FRUIT.—Mr. G. R. Allis, gardener to Major Shuttleworth, Old Warden, was awarded first prize for two grand bunches of Black Alicante in the class for black Grapes; Mr. H. Landers, gardener to S. Whitbread, Esq., Southill Park also having fine bunches for second. Mr. R. Day, gardener to the Mayor of Bedford also showing Black Alicante very creditably for second. For two bunches of white Grapes Mr. Allis staged Pearson's White Queen in fine condition, and was awarded first place. A very fine display of Apples and Pears was made, Mr. Landers coming first for dishes of culinary Apples with remarkably fine Alexanders, Blenheim Pippins, and Golden Nobles, Mère de Ménage being somewhat *passée*. For four dishes of dessert Apples Mr. Landers was also first with Cornish Gilliflower, Worcester Pearmain (?), Cox's Orange, and Blenheim Pippin. For single dishes of culinary and dessert Apples, Mr. Allis and Mr. Landers were first respectively with Blenheim and Cox's Orange Pippin. For four dishes of Pears Mr. Landers was first with Triomphe de Jodoigne, Benrè Superfin, Hacon's Incomparable, and Conseiller de la Cour; Mr. G. Vyne being first in each class for single dishes of eight dessert and stewing Pears, and Mrs. Edwards, Alexandra House, Bedford, for six stewing Pears with Catillac.

VEGETABLES were well and largely represented, some very fine Cauliflowers being staged by Mr. Ellis, gardener to Mrs. Orr, Pembrey, Bedford, who was first here, and also for two dishes of round Potatoes. For a collection of eight varieties of vegetables Mr. G. Robinson was first, and for a collection of Potatoes, Mr. G. Watton, Argyll Street, Bedford, showed The Dean, Sutton's Seedling, Snowdrop, Vicar of Laleham, Schoolmaster, and Village Blacksmith in fine form, and was placed first. Mr. Ellis, Mr. Watton, Mr. H. S. Sell, and Mr. F. W. Clayton, Luton, also took first prizes for single dishes of Potatoes; Mr. S. Dawson of Clapham, Beds, for a collection of six varieties of vegetables. Mr. G. Johnson, Bedford, was first for fine Intermediate Carrots, and Mr. W. Quarry, Bedford, for twelve fine and true white Spanish Onions.

Mr. Wm. Colchester of Ipswich, exhibited his pure Ichthemis Guano, a well appreciated vegetable and plant fertiliser, and Mr. H. Thody received high commendation for his valuable Orchids not for competition.

#### FAREHAM.

A GRAND Chrysanthemum Show and Bazaar was opened on Thursday, at the Town Hall, Fareham, by Lady Fitz-Wigram, in aid of the restoration of the parish church. Sir Frederick Fitz-Wigram, M.P., remarked that the Chrysanthemum Show and Bazaar had been arranged to help on a great and noble work. He was sure that in Fareham there would be willing hands and generous hearts, and that the work would be carried out completely and successfully. Messrs. Goble and Warner kindly placed their large offices at the hands of the Committee for the Chrysanthemum Show, which was conducted by Mrs. E. Goble. Over £430 was taken at the bazaar, and about 900 paid for admission to the Chrysanthemum Show. Messrs. W. and G. Drover carried out the arrangement of the Show, the firm sending twenty dozen specimen blooms—Japanese, incurved, reflexed, and Anemones—also showing their new Japanese W. G. Drover, which has been awarded certificates at Birmingham and Southampton. The cut blooms were sold, and realised good prices, in aid of the above fund.

#### CHICHESTER AND WEST SUSSEX.

THIS Show took place last Thursday at the Corn Exchange, the building again proving none too large for the reception of the exhibits. Several new competitors entered the lists. The groups arranged for effect, 60 feet square, made a fine display. Mr. J. Barnes, gardener to H. W. Gibbings, Esq., staged a fine collection, well set up, and an easy first. Mr. Alderman Purchase was a successful exhibitor, and Mr. G. Lambert showed well in specimen plants, which gained him a prize; he has taken many prizes in previous seasons at this show. In cut blooms Messrs. W. and G. Drover, as usual, excelled, carrying off the first in open classes; also setting up forty-eight not for competition. Their Japanese—including their certificated ones, Maggie Mitchell, W. G. Drover, Gloriosum, Bicolor, and White Dragon—showed the other varieties well up. Their incurved were not quite so good as those shown at Southampton, Portsmouth, Crystal Palace, &c. Table decorations made a grand display. The decision of the lady Judges caused some criticism during the day. In the classes for cut blooms there was a keen competition, the blooms surpassing all previous shows. Collections of vegetables, not less than twelve distinct sorts, was well contested. General Hardy, C.B., first; the Right Rev. the Lord Bishop of Chichester, second. The Judges were—Mr. Breese, gardener to Lord Leconfield, Petworth; and Mr. Conoway, gardener to the Marchioness of Bath, Worthing. They had no little difficulty in awarding some of the prizes. To Mr. H. H. Moor, the popular Secretary, and the Committee, great credit is due for the way the Exhibition was carried out.

#### PONTEFRAC.—NOVEMBER 25TH AND 26TH.

FOR the first time in its long history a Chrysanthemum Show was held in this clean, quiet, breezy town, on the dates named. Though the town itself is not large—10,000 inhabitants—it is the centre of a populous and fertile district, therefore well adapted for exhibitions of garden produce. The Pontefract, Knottingley, and Ackworth Chrysanthemum Society has for its President Lord St. Oswald, and his lordship's late gardener (Mr. W. J. Ireland) took an active share in its establishment, and was appointed Chairman of the Committee, Mr. T. Ketchell, Ackworth, one of the most successful competitors of the Show, being the Vice-Chairman. The Exhibition was held in the Assembly Room, a considerable sized and lofty hall, with an orchestra at one end and a narrow gallery surrounding the building. The groups of plants were arranged in the body of the hall, the cut blooms and other products round the gallery, except the blooms in the chief open class, which were honoured by a position at the front of the orchestra. A first glance at the Show revealed the fact of its being too large for the building, and the way in which the curators, Messrs. Sheen, Ackworth, & Sunley, Milford Junction, disposed of the exhibits, with which they may be said to have been embarrassed, was highly creditable to their ingenuity and taste.

Groups of plants arranged for effect constituted the most prominent feature. In the open class for miscellaneous plants seven semicircular groups were disposed round the sides of the hall under the galleries, an equal number of groups of Chrysanthemums, each occupying 100 square feet, being disposed in the body of the building, the central group circular, the others irregular ovals. These left but little space for visitors passing between them, and the effect of the huge mounds of flowers as viewed from the gallery was rich in the extreme. This latter and more imposing class was confined to local exhibitors, and they are to be congratulated on their work, for it is safe to assert that an equal number of finer groups have never been seen at a first show of any society, while those which won the chief prizes afforded evidence of good culture combined with good taste not always excelled at established shows. The first prize in this class was won by Mr. Temple, gardener to Lord St. Oswald, Nostell Priory, with a bold, bright, free arrangement of admirably grown plants, not a few bearing blooms good enough for prize stands, and though they were not too thinly nor formally disposed there was an absence of close packing, and the effect was highly agreeable. The margin was formed with dwarf bush-grown Pompons. Mr. T. Ketchell, gardener to C. Simpson, Esq., Ackworth, was a very close second with a group of semicircular character, and imposing, the remaining prize falling to Mr. Madcock, gardener to R. Moxon, Esq., with a bright mass, but a little packed. The other groups were better than many we have seen win prizes, but the general smallness of the flowers, except in one instance, keeping them beyond the charmed circle, and in the exception the plants were too few to be effective. All the exhibitors of these groups merit the recognition of the Committee, so well did they contribute to the success of the Show. In the miscellaneous groups of stove and greenhouse plants, Mr. Ketchell was placed first with a beautiful arrangement of Palms, Crotons, Poinsettias, Eulalias, Roman Hyacinths, and Ferns; Mr. W. Pearson, gardener to W. Jackson, Esq., being a close second; and Mr. J. Lamprey, Ackworth, an excellent third, some of the remaining collections being also good. Specimen Chrysanthemums were exhibited by Messrs. Temple, Ketchell, Neil, and Williams, who appeared to secure most of the prizes, but there is room for improvement in this section, and where dwarf training had been resorted to the growths were laced too closely down; bent or twisted stems should not be apparent.

Prizes of £5, £3, and £2 were provided in an open class of thirty-six blooms, in not less than sixteen incurved and the same number of Japanese varieties. Three competitors entered the list, but the contest for the premier position lay between Mr. W. Daniels, gardener to Mrs. T. Cook, Mirfield, and Mr. J. Boyle, gardener to Mrs. Shaw, Oldham; and after a close examination of all the blooms the Judges had no difficulty in deciding in favour of the first-named exhibitor. The incurves were even, solid, fresh, and of good size, and Japanese large and bright. The varieties were arranged in the stands in the following order, reading each row from left to right:—Incurved, back row—Queen of England, Empress of India, Alfred Salter, Lord Alcester, Alfred Salter, and Empress of India. Second row—Hero of Stoke Newington, John Salter, Jeanne d'Arc, John Salter, Mr. Bunn, and Lord Wolseley. Front row—Barbara, Beauty, Nil Desperandum, White Venus, Empress Eugenie, and Beyerley. Japanese—Boule d'Or, Madame C. Audiguier, Meg Merrilies, Criterion, Fair Maid of Guernsey, and Boule d'Or. Middle row—M. J. Laing, L'Adorable, Madame J. Laing, J. Delaux, M. Tarin, and Val d'Andorre. Front row—M. Burnet, Madame Lacroix, M. Freeman, Belle Paule, Duchess of Albany, and Madame Moulise. Many of Mr. Boyle's incurved blooms were very fine indeed, notably John Salter, Alfred Salter, Princess of Wales, Hero of Stoke Newington, and Cherub, but some lacked solidity and freshness, were in fact a week too old, and the Japanese were comparatively weak in contrast with the others, yet Mr. Boyle was a strong opponent to vanquish on the occasion. Mr. R. Morris, Doncaster, was the third prizewinner.

In the local classes the Japanese blooms were, as a rule, far superior to the incurved, though some very good Anemones and reflexed were staged. A silver cup given by J. Taylor, Esq., was added to the first prize in the class for twenty-four blooms, twelve incurved, in not less than six varieties, and the same of Japanese, this being won by Mr. Dunn, gardener to Mrs. Jones, Elmsall Lodge, with fresh and good incurved, though some rather small, and bright medium sized Japanese. Mr. Temple was second with finer Japanese, but flatter and looser incurved. In the class for twelve of the latter, and for twelve reflexed, and twelve Anemones, Mr. Ketchell was first with very good stands indeed. There was great competition in the class for twelve Japanese, Mr. Temple securing the leading position with a stand of fine blooms, including a grand Criterion, which ran Mr. Daniels' Boule d'Or closely as the best in the Show. The prize for the best incurved was also awarded to Mr. Daniels for a compact and very bright John Salter. The remaining prizewinners for twelve Japanese were Messrs. Ketchell and Neil. This exhibitor also staged the best Roman Hyacinths, and Mr. Moxon the best Primulas, both being very good. Bouquets were of good average merit, the best miscellaneous bouquet, very free and chaste, being staged by Mr. Sunley, the best of Chrysanthemums by Messrs. L. and R. Callam. We are not able to enumerate all the prizewinners, and it must suffice to say that Mr. Lazenby staged the best black and white Grapes—

Gros Colman and Muscat of Alexandria; that there was good competition in Apples and Pears; and that a splendid assortment of these fruits was sent by Messrs. Richard Smith, & Co., Worcester, and a large and good collection from Messrs. Jas. Backhouse & Sons, York.

The Show must be regarded as highly satisfactory and encouraging, and Mr. T. Glover, the Hon. Secretary, and his coadjutors are to be congratulated accordingly. With a continuance of support, the same good management and more room, Pontefract shows may be expected to attain a good position in the Chrysanthemum world.

#### WELLINGTON (SOMERSET).

CHRYSANTHEMUM Shows are becoming fairly numerous in Somerset, nearly every town of importance now holding its annual meeting. Mr. C. Tite, who has had some experience in starting fresh societies, was mainly instrumental in bringing together a good display of both Chrysanthemums and fruit at Wellington, and with the help of an influential Committee will doubtless succeed in arranging for a good annual exhibition. Mr. J. Denner, gardener to C. H. Fox, Esq., Shute Leigh, Wellington, was the most successful exhibitor of plants both in the open and local classes, and he also sent some fine Chrysanthemums and other plants for the adornment of the hall in which the Show was held. Dr. Meredith was also successful with plants. The best display of cut blooms, any varieties, was made by Mr. C. Cooper, gardener to C. L. Collard, Esq., Abbotsfield, Wiveliscombe, and the same exhibitor was again first for both twelve incurved and twelve Japanese varieties. Altogether he had very good blooms, some of the best of which were:—Incurved.—Lord Alcester, Sir Stafford Carey, Empress of India, Mr. Howe (John Salter), Hero of Stoke Newington, Lady Hardinge, Mrs. W. Shipman, Jeanne d'Arc, and Alfred Salter. Japanese.—Thunberg, Madame C. Andiguer, Ralph Brocklebank, Comtesse de Beanregard, Mons. Brunet, Boule d'Or, and Triomphe de la rue des Châlets. Reflexed.—Cullingfordi, Pink Golden, and Peach Christine, Cloth of Gold, Chevalier Domage, and Felicity. Mr. J. Denner took several prizes for cut blooms, staging in addition to most of the varieties just named the comparatively new Japanese *Sonvenir d'Ange*, *Amiel*, *Maiden's Blush*, *Moonlight*, *Martha Harding*, and *Gloriosum*. Mr. Reuben Richards also sent capital blooms, including *Anemone-flowered Sœur Dorothee Souille*, *Madame Clos*, *Ratapail*, *Lady Margaret*, and *Empress*. Mr. R. McMillan, gardener to Sir George Stuckley, Moreton House, Bideford, and Mr. G. J. Barnes, gardener to T. C. Daniel, Esq., Stoolleigh Court, Tiverton. Each had several stands of good blooms, which fully deserved the prizes awarded to them. Miss Poynter, Taunton; Miss Clarke, Wellington; the Misses Elworthy, Wellington; and Miss F. L. Morgan, Wellington, were all awarded prizes in the classes for bouquets, vases and baskets of flowers, good taste being displayed throughout.

Mr. C. Cooper took the first prize in the class for two bunches of black Grapes with good Alicante, Mr. G. J. Barnes being second with the same variety, and Mr. Crossman, gardener to J. Brutton, Esq., Yeovil, third. A second prize was awarded to Mr. Crossman for white Grapes, and he also took a prize for Apples. Other successful exhibitors of Apples and Pears were Messrs. C. Cooper, T. Pyne, J. Nation, W. P. Martin, J. Bowerman, and S. R. Morgan. Messrs. R. Veitch & Son, Exeter, contributed a fine collection of Apples and Pears and cut Chrysanthemums, but not for competition; as also did Messrs. Lacombe, Pince & Co., Exeter. Mr. Godding, nurseryman, Taunton, sent some flowers; and good Chrysanthemums were staged by Messrs. Stevens & Cann, Exeter. Mr. W. G. Clarke, nurseryman, Wellington, in addition to about 100 sorts of Apples and Pears, also lent a great variety of choice pot plants. From W. G. Marshall, Esq. (W. Marshall, gardener), Taunton, came several fine stands of Chrysanthemum blooms; and Mr. John Bowerman, Cornhill, gave good assistance in the shape of plants, as also did Mr. F. T. Elworthy, Foxdown.

#### LIVERPOOL.—NOVEMBER 29TH AND 30TH.

THIS Show was held in St. George's Hall on Tuesday and Wednesday last, and proved one of the very best the Society has ever held. The morning was very wet and foggy, but exhibitors came in good numbers and almost threw the stagers into confusion; but they managed excellently, in spite of the increased number of exhibits, and not being able to have the Hall the night previously. The plants generally were good, both stove and greenhouse, as well as the trained Chrysanthemums, while the untrained specimens showed a great improvement upon those of previous years. The fruit was excellent, and the cut blooms of Chrysanthemums were never so numerous. The Japanese were superior to what has ever been exhibited at Liverpool before, while the Show was just a week late for the incurved. The best blooms in the Show were those staged by Mr. Mease. Mr. A. R. Cox followed with some excellent flowers, as will be observed from the list of prizes. We regret very much that time and space prevented our dealing with many exhibits.

CUT BLOOMS.—These were more numerous than during any previous show held by the Society, for no less than 1700 were entered in the various classes for competition. Fully 1600 blooms of this number were staged. Taking the blooms throughout, they were of better quality than during previous years; this was specially noticeable with the Japanese, which were both larger and brighter in colour. In the class for forty-eight blooms, thirty-six distinct varieties, no less than four exhibitors staged blooms, and the competition was close. Mr. A. R. Cox, gardener to W. H. Watts, Esq., Elm Hall, Wavertree, gained the silver tea service given by Messrs. J. Williams & Co., Mount Pleasant, Liverpool, and £3 as the first prize, with neat, fresh, solid, incurved flowers, which were particularly even, and the same feature marked his Japanese blooms. The varieties were, reading from the left hand corner in each case—Incurved: Back row—Golden Empress, Empress of India, Queen of England, Lord Alcester, Empress of India, Golden Empress, Queen of England, and Lord Alcester, all large fine blooms. Middle row—Lady Hardinge, Jardin des Plantes, Princess of Teck, John Salter, Princess of Teck, Lord Wolsley, Jeanne d'Arc, and Empress Eugénie. Front row—Barbara, Princess of Wales, Mrs. W. Shipman, Mr. Bunn, Hero of Stoke Newington, Mrs. Heale, Lady Hardinge, and Cherub. Japanese: Back row—Boule d'Or, Fair Maid of Guernsey, Mons. Brunet, Meg Merrilies, Baron de Prailly, Boule d'Or, Belle Paule, Ralph Brocklebank. Middle row—Meg Merrilies, Jean Délaux, Ralph Brocklebank, Belle Paule, Martha Harding, Mons. As.org,

Jean Délaux, Criterion. Front row—Comte de Germiny, Mdlle. Lacroix, Le Sceptre Toulousain, Japonaise, Triomphe de la rue des Châlets, Madame C. Audiguer, Mdlle. Lacroix, and Duchess of Albany. Mr. J. Jellico, gardener to F. H. Gossage, Esq., Camp Hill, Woolton, gained the second award of £6 for fresh neat even flowers, being six points behind the first prize collection. Third, Mr. F. Roberts, gardener to W. D. Holt, Esq., West Derby, with one point over his opponent, Mr. J. Wilson, gardener to E. Reynolds, Esq., Sancesfield Park West Derby, who was deservedly awarded an extra prize.

In the class for thirty-six blooms, eighteen incurved, and the same number of Japanese, for which the Veitch Memorial medal was obtained and £5. Three exhibitors staged blooms for this coveted prize, and Mr. Wm. Mease, Wyncote, Allerton, was well ahead, having grand flowers in both sections, and this exhibit contained some of the finest flowers in the exhibition. The varieties were incurved. Back row—John Salter, Alfred Salter, Lord Alcester, B onze Queen of England, Empress of India, Queen of England. Middle row—Emily Dale, Lord Wolsley, Jardin des Plantes, Princess of Wales, Mrs. Cullingford, Golden Empress. Front row—Princess of Teck, Cherub, Hero of Stoke Newington, Angelina, Jeanne d'Arc, and Empress Eugénie. Japanese.—Back row—Boule d'Or, Madame J. M. Pigny, Ralph Brocklebank, Madame C. Andiguer, Fair Maid of Guernsey, Gloriosa, fine. Middle row—Belle Paule, Triomphe de la rue des Châlets, Japonais, Meg Merrilies, Baronne de Prailly, Madame B. Pigny. Front row—L'Adorable, Madame J. Laing, Mdlle. Lacroix, Criterion, Jeanne Délaux, and Golden Dragon. Mr. J. Jellico and Mr. R. Foster were the other two competitors in this class.

For twenty-four incurved five exhibitors staged blooms. Mr. G. Eaton, gardener to W. H. Shirley, Esq., Allerton Road, took the lead with neat fresh flowers; second, Mr. D. Forbes, gardener to A. Holt, Esq., Crofton, Aisburgh, some of the flowers being rather flat; third, Mr. G. Burden, gardener to G. Cockburn, Esq., Claughton. For eighteen incurved, distinct varieties, Mr. J. Jellico was successful with fresh even flowers; second, Mr. T. Foster, gardener to J. Braucker, Esq., Green Bank, Wavertree, with rather loose and rough blooms; Mr. W. Wilson was the remaining prizewinner. Four collections were staged. In the class for twelve incurved six stands were staged, and Mr. A. R. Cox took the most prominent position with large grand flowers in the back row and neat even ones in the other two; second, Mr. G. Burden; third, Mr. T. Foster. In the corresponding class for twelve four competitors staged, and Mr. W. Mease was well ahead with large flowers of Lord Alcester, Empress of India, Bronze Queen, Queen of England, John Salter, Alfred Salter, Princess of Wales, Golden Empress, Empress Eugénie, Hero of Stoke Newington, Refulgence, and Princess of Teck. Mr. G. Buttler, gardener to T. Drysdale, Esq., Mossley Hill, was a good second, and Mr. G. Lyon, gardener to J. H. Kenon, Esq., third.

In the class for twenty-four Japanese, distinct varieties, Mr. G. Eaton was placed first with large very fresh flowers of Belle Paule, Japonais, Fair Maid of Guernsey, Boule d'Or, Madame J. Laing, Triomphe de la rue des Châlets, Golden Dragon, Comtesse de Beanregard, Criterion, M. Astorg, Jean Delaux, Madam Paul Dutour, L'Or du Japon, Meg Merrilies, Comte de Germiny, L'Adorable, Roseum Superbum, M. Freeman, Peter the Great, Lady Matherson, Coquette de Castilles, Thunberg, Val d'Andorre, and Mdlle. Lacroix. Mr. J. Jellico was a good second, and Mr. R. Foster, gardener to S. H. Thompson, Esq., Thingwall Hall, Broad Green, third. Five collections were staged in this class. For eighteen varieties four or five collections were staged, Mr. A. R. Cox took the lead with excellent flowers, followed by Mr. J. Jellico and Mr. D. Forbes. For twelve blooms Mr. Wm. Mease took the lead, followed by Mr. C. Osborne, and in the corresponding class for twelve Mr. John Wilson was first. In each of these classes the competition was good, and in many cases very close. For the premier Japanese bloom in the Exhibition Mr. W. Mease was given the award for a fine bloom of Boule d'Or, and Mr. A. R. Cox had similar honours for Lord Alcester amongst the incurved.

Stove and greenhouse plants were as numerous and as good as in previous years. For six plants Mr. A. R. Cox was well ahead, with *Ixora coccinea*, *Pleococoma prolifera* B. nesi, *Azalea amena*, *Croton Queen Victoria*, *Litania borbonica*, *Calamus ciliaris*. Mr. A. Crosbie, gardener to B. Hall, Esq., was a good second. For four plants Mr. A. Crosbie first, with *Erica hymalis*, a good *Bouvardia*, and *Cycas revoluta*, and *Croton Queen Victoria*. Mr. A. R. Cox was a good second. For three Palms Mr. A. Crosbie was successful with very fresh examples of *Litania borbonica*, *Cocos Weddelliana*, and *Kentia Borbonica*. Second, Mr. J. Jones, gardener to W. C. Clark, Esq., Sifton Park; and Mr. A. R. Cox third. For one Palm Mr. A. R. Cox was first, followed by Mr. A. Crosbie. For four Ferns Mr. A. R. Cox was first with well grown plants of *Cibotium Schiedei*, a fine *Gonolophium*, and a seedling *Polystichum*. Mr. F. Smith was a close second, and Mr. Thomas Gowan third in the class for four plants. For one Tree Fern Mr. A. R. Cox was first.

Table plants were staged in their usual style, being small, light, and very even in size. For six plants Mr. J. Jellico took the lead with *Dracena Guillolei*, *Croton albatensis*, *Aralia Veitchi gracilima*, *Pandanus Veitchi*, *Kentia F. steriana*, and a *Draena*; second Mr. J. Agnew, with a capital lot; and third Mr. T. B. Thel, gardener to A. Guthrie, Esq.

CHRYSANTHEMUMS IN POTS.—These as usual were of the best quality, being neat and fresh. For four plants of Pompons Mr. J. Harrison, gardener to Mrs. W. G. Baeson, was first with excellent samples of *Macon Model*, *Yellow* and *White Cedo Nulli*. For four large flowering varieties the same exhibitor again took the lead with Mrs. Dixon, Mr. Howe, Mrs. G. Rundell, Lady Hardinge. For one plant Mr. J. Hughes took the lead with Mrs. Dixon. For six bushes Mr. W. Bustard was first with better examples than have before been seen at the Society's show. Mr. Peter Barber, gardener to A. Barnsley, Esq., was placed second. Groups of Chrysanthemums were exhibited for the first time, and great improvement is noted before they can compare favourably with those that are shown at various exhibitions in the country. Mr. W. Bustard was placed first, and Mr. Peter Barber second.

Primulas were good, better than they have been for some years. Mr. W. Tunnington, gardener to Mr. McIver, Calderstone, was deservedly first, Mr. J. Harrison was second, and J. Hughes, gardener to H. McIver, Esq., third.

Orchids were not so plentiful as has been represented on many previous



occasions, but those staged were good. For one *Cypripedium* Mr. T. Gowan was first with a large plant of *C. insigne*, very profusely flowered. For three Orchids Mr. W. Tunnington was first with *Odontoglossum Alexandræ*, *Zygopetalum Mackayi*, and *Calanthe vestita*. For one *Calanthe* Mr. W. Tunnington was again first. Second Mr. McGarth, gardener to R. R. Heap, Esq., West Derby. For one Orchid Mr. A. Smith, gardener to D. de Yboorande, Esq., with *Vanda Sanderiana* with seven or eight fine flowers. Second Mr. J. Bounds with *Cypripedium insigne*.

**FRUIT.**—The display of fruit was an exhibition in itself, and every class was well represented. In the open class for twelve dishes, distinct, Mr. J. H. Goodacre, gardener to Earl of Harrington, Elvaston Castle, gained the premier position with a large Pine, good Muscat of Alexandria Grapes, Lady Downe's, fair Gros Colman and Mrs. Pearson; Pears, Beurré Diel, (large), and Beurré Clairgeau; Apples, King of the Pippins (fine colour), Blenheim Pippin (large and fine); a good dish of Red Currants, Coe's Late Red Plum, and a fair Hero of Lockinge Melon. Mr. J. Bennett, gardener to the Hon. C. H. Wynne, North Wales, having good Lady Downe's Grapes and Blenheim Pippin Apples, really superb. Mr. W. Hanagan, gardener to R. C. Naylor, Esq., Horton Hall, Cheshire, the remaining award. Four collections were staged. For six dishes the same competitor was again first, having particularly good Muscat of Alexandria and Gros Colman Grapes, the latter being large in the berry and splendidly finished; the same may be said of the former, but the bunch was large. The same kind of Melon, Pears, and Plums were staged as in the previous class. Mr. Hanagan was second, having good Apples and Pears, the Grapes being short of finish. Third, Mr. J. Bounds, gardener to A. L. Jones, Esq., Oaklands, Aigburth, four collections being staged.

Grapes throughout were exceptionally good, being large in the bunches, berry, and generally well coloured. In the class for four bunches, distinct, Mr. J. H. Goodacre took the lead with large, well-finished bunches of Lady Downe's, Muscat of Alexandria, very good; Mrs. Pearson, grand; and Gros Colman, a little short of colour, but the berries were exceptionally large. Second, J. Hollingsworth, gardener to J. F. Campbell, Esq., Woodseat, Uttoxeter, having well-finished Alicante and Gros Guillaume. Third, Mr. J. Barker, gardener to G. T. Raynes, Esq., Rock Ferry. No less than nine exhibitors staged in this class. For two bunches of Muscat of Alexandria there was four competitors, and the whole were really first class. Mr. D. Lindsay, gardener to Sir T. Edwards Mos, Bart., Otterspool, Liverpool, took the lead with large heavy, perfectly finished examples, followed by Mr. G. Middleton, gardener to R. Pilkington, Esq., Rainford Hall, and Mr. John Bounds, who were second and third respectively. For two bunches of any other white variety, eight lots were staged. Mr. J. H. Goodacre took the lead with superb bunches of Mrs. Pearson; Mr. J. Hollingsworth second with Golden Queen; and Mr. A. Collins, gardener to S. Smith, Esq., M.P., Prince's Park, third with the same variety. For two bunches of Black Alicante nine competitors staged, and the Judges had some difficulty in determining the awards, for there was not a faulty bunch in the whole. Mr. J. Downham, gardener to E. H. Harrison, Esq., Eastham, was deservedly placed first for large bunches, with even berries, and perfect in bloom and finish. Mr. W. Wilson, gardener to H. Cunningham, Esq., Gorse Cop, Wavertree, was a close second, and Mr. J. Hollingsworth a good third. An extra prize was awarded to Mr. E. Gregg, gardener to W. O. N. Shaw, Esq., Birkenhead. For two bunches of black Grapes with Muscat flavour, Mr. J. Hollingsworth was successful with two large bunches of Mrs. Pince, a little short of colour. Second, Mr. J. Richards, gardener to E. C. Friend, Esq., Rock Park, Rock Ferry, with neat examples of Madresfield Court. Third, Mr. J. Wallis, gardener to Rev. Walter Sneyd, Kee's Hall, Staffordshire, with the same kind. For two bunches any other black, Mr. J. Hollingsworth took the lead with Lady Downe's, very good; Mr. A. Collins second with large bunches of Gros Guillaume. Third, Mr. J. Downham, with grand bunches of Gros Colman. Five lots were staged.

Apples were very numerous, and the quality was better than that of previous years, the colour was particularly well developed in many of the varieties. For six dishes of dessert kinds, distinct, Mr. J. Davis, gardener to Rev. H. Arkwright, Bodenham, Leominster, took the lead with grand examples of Blenheim Pippin, Prince's Pippin, Cox's Orange Pippin, Court Pendu Plat, and Rosemary Russet; second, Mr. Hannagan; third, Mr. J. H. Goodacre. No less than eight collections were staged. In the class for three dishes fourteen collections were staged for the prizes offered. Mr. W. Hannagan was placed first with King of the Pippins, Blenheim Pippin, and Ribston Pippin; second, Mr. J. Loundes, gardener to S. S. Parker, Esq., Sudley Road, Aigburth; third, Mr. T. Elsworthy, gardener to A. R. Gladstone, Esq., Court Hey, Broad Green. For one dish the Rev. L. Garnett, Christleton Rectory, was successful. For eight dishes of culinary kinds Mr. J. Davis was well ahead with very large fine examples of Alfriston, Welford Park, Nonesuch, Hollandbury, Winter Nonesuch, Blenheim Pippin, Peasgood's Nonesuch, Warner's King, and Emperor Alexander; second, Mr. J. H. Goodacre; third, Mr. Hannagan. Nine or ten lots were staged. For four dishes Mr. R. Pinnington, gardener to E. Banner, Esq., Roby, was well first with Nelson's Glory, Blenheim Pippin, Mère de Ménage, and Alfriston; second, Mr. Hannagan; third, Mr. W. Mease. About the same number of collections were staged as in the preceding class. For one dish Mr. J. Downham was successful, twelve or more dishes being exhibited.

Pears were not perhaps quite equal in numbers to what we have before seen them, but the quality was all that could be desired. For eight dishes five collections were staged, and Mr. J. H. Goodacre was well first with Beurré Diel, Beurré Clairgeau, Beurré Bachelier, Glou Morceau, Duchesse d'Angouleme, Easter Beurré, Marie Louise, Doyenné du Comice; second, Mr. W. Mease, and third, Mr. J. Hannagan. For four dishes six or seven lots were staged, and Mr. R. Foster gained the leading honours, followed by Mr. Hannagan and Mr. R. Pennington. For one dish of dessert Mr. R. Foster was first with Marie Louise, and Mr. J. H. Goodacre for one dish of stewing Pears.

**MISCELLANEOUS EXHIBITS.**—These contributed largely to the attractions of the Exhibition, and were more numerous than usual. Messrs. Fishlock Brothers received a certificate of merit for crosses, wreaths, and bouquets. The Liverpool Horticultural Company (John Cowan), Garston, the same award for a similar exhibit and a collection of stove and greenhouse decorative plants, including Orchids. Messrs. R. P. Ker & Sons, a cultural certificate for an excellent collection of Cyclamens, well grown and most pro-

fusely flowered. Messrs. Cutbush & Sons, Highgate, London, certificate of merit for Pernettyas, well berried in pots. Mrs. Southam, a certificate of merit for dried flowers under glasses and in frames. Mrs. Vestey the same award for skeleton leaves. An extra prize awarded for four double Primulas to Mr. J. Bounds. To Messrs. Davis & Sons for Chrysanthemums, a yellow sport from Princess of Teck named Mrs. N. Davis, a first-class certificate also for Chrysanthemum Mr. Charles Gibson, a sport from Mrs. N. Davis, also for Annie Lowe, a sport from Lady Margaret Anemone flowered. Messrs. F. and A. Dickson & Sons were highly commended for a collection of Apples and Pears, and the same award for Messrs. James Dickson and Sons. Messrs. C. Rylance & Co., highly commended for a collection of Apples, also the Covent Garden Seed and Bulb Company. Mr. John Walkin a certificate of merit for a collection of Apples. A seedling Apple, not named, highly commended, exhibited by Mr. W. Neild, Wythenshawe.

The Chairman (Mr. White), the Secretary (Mr. E. Bridge), and the Committee deserve every congratulation for the manner in which they carried out the various details of this large and splendid Exhibition.



#### FRUIT FORCING.

**VINES.**—*Houses to Afford Grapes in May.*—The Vines that are to afford Grapes at the time stated must be started without delay, nothing contributing more to a good break than a bed of leaves and stable litter placed on the floor of the house, and turned daily. The outside border should have the needful protection from cold rains and snow, two-thirds of leaves to one of stable litter affording a less violent but more lasting heat than dung. Provided the outside borders were covered with bracken, straw, or litter in early autumn so as to throw off the wet, the temperature will be considerably warmer than that of borders exposed, and in their case covering with hot litter may be dispensed with, but a covering of warm litter is preferable, especially to those borders exclusively outside. The inside borders should be brought into a thoroughly moist state by applying water, and in the case of weak Vines give liquid manure at 90°. Start with a night temperature of 50° in severe weather, 55° in mild weather, and 65° by day, except the weather be severe, when 55° will suffice, not exceeding those figures until the growth commences. Maintain a moist atmosphere by syringing occasionally, but excessive moisture excites the emission of aerial roots from the rods. Depress the rods of young Vines to the horizontal line or below it to insure the regular breaking of the eyes.

*Houses Started Early in November.*—In the earliest house, whether the Vines are in pots or are planted in borders, the temperature will need to be increased to 60° at night in mild weather, 55° in severe weather after the buds break, and gradually increasing so as to have it 60° at night when the Vines are in leaf, 65° by day in severe weather, and 70° to 75° in mild weather with moderate ventilation. The evaporation troughs need not as yet be charged with liquid manure provided there are fermenting materials in the house, but if not the evaporation troughs should be filled with the drainings of the dungyard or stables, cow byres, &c., avoiding, however, that of pigstyes. Failing those use 1 lb. of guano to 20 gallons of water, which is also suitable for watering Vines in pots, the water being applied at the temperature of the house. Tie up the Vines in position as soon as growth has well commenced, and before the shoots are so long as to be liable to be damaged in the process. Sprinkle the house two or three times a day in clear weather, avoiding a close atmosphere on the one hand and a dry one on the other. Dishudding should not be practised until the fruit shows in the point of the shoots.

*Midseason Houses.*—The Vines from which the Grapes have been cut should be pruned; indeed it is decidedly advantageous to prune the Vines directly the leaves have fallen, any Grapes still hanging having been cut and placed in bottles of clear rain water with a piece of charcoal in each. The Grapes will often keep better than on the Vines, as the temperature in the Grape room is more equable than can be commanded in a vinery. Keeping Grapes hanging after the leaves have fallen may not be prejudicial to Vines unless prolonged to a late period, yet the greater extent of young wood keeps the sap more or less in circulation, and there is a certain amount of waste going on which cannot take place when the Vines are pruned. Prune, therefore, directly the leaves are all down, cut and bottle any Grapes at that time remaining, they being of the thin-skinned varieties, and not requiring the maturing so necessary for such varieties as Gros Colman and thick-skinned varieties generally. In pruning adhere to the system that has proved satisfactory. If the Vines are in good condition they will in all probability give sufficiently large bunches if pruned to one, or at most two eyes, good useful Grapes for everyday use on the cut-and-come again principle, so essential when the table must be supplied with fresh fruit. But if larger bunches are wanted, or the Vines from weakness do not afford bunches so large as desired, leave more growth, only be careful to select sound, round, well developed buds on firm well ripened wood. Aim, in fact, at finish. Large bunches invariably are defective of the finish of medium-size bunches. Vines that afford well-finished example pruned



to one bud will give a larger bunch and of equal finish from the second bud. If the soil be rich, loose, and plentiful, the chances are the shoots or canes will be gross, long-jointed, having large thin-textured leaves, the buds large, pointed, or if laterals are encouraged flat, and these may give the sensational bunches, which justly have their merits calculated by weight. If, on the other hand, the roots are in a firm but favourable rooting medium, causing an increase of root ramifications, then the wood will be stout and short-jointed, the leaves thick and leathery, and the buds at their base will be round, plump, and well matured. It is, of course, assumed the foliage has full exposure to light for the solidification of the growth as made, and that cultural requirements are granted in full measure.

We endorse Mr. W. Taylor's opinion, expressed rather more than a year back, that our older, and it must be said higher quality Grapes, are not seen with so high a finish as they were when mere size was not thought so much of as at present. Let the Vines be dressed, the house thoroughly and everything put into order, so that there need be no hurry to put things straight. Keep the house as cool as possible, so as to insure complete rest.

**Late Houses.**—Every precaution should be taken against damp. The most prolific cause of Grapes not hanging well is drip, it being useless striving to keep Grapes beneath a leaky roof, as a single drop of water getting inside a bunch of Grapes is sufficient to spoil it, though the decay of it may be only a berry, which being in the interior is not detected until the disaster is so spread as to spoil the bunch. Remove all leaves as they become ripe, affording only sufficient fire heat to exclude frost, keeping at 40° to 45°, and close the house in damp weather, and seeking to insure a dry, cool, and equable temperature.

**CUCUMBERS.**—The winter fruiterers are showing plenty of fruit. Unless the plants are extra strong two-thirds of the fruit should be removed, removing also the male blossoms and tendrils, with any superfluous shoots and bad leaves, but do not stop the growing points overmuch for the next few weeks, affording water moderately—a supply twice a week will suffice. Cucumber plants growing in pots or boxes will require water oftener, with liquid manure occasionally. A night temperature of 65° to 70°, falling to 60° in severe weather, 70° to 75° by day, advancing to 80° or 85° with sun, will be suitable. The plants will require moderate forcing from time to time, taking care that the soil has been previously warmed, press it firmly, but not hard. The bottom heat should be kept steady at about 80°. Atmospheric moisture will require to be moderate, damping only on bright mornings or early in the afternoon. If a night covering be afforded of mats or frigi domo to the glass it will be highly advantageous, but it must not remain on by day to the exclusion of light, every ray of which the plants must have. Remove old foliage and exhausted growths from the autumn fruiterers, but do not overstop the growing points, avoiding overcrowding and especially overcropping. Fertilise the flowers during a continuance of dull sunless weather.

**CHERRY HOUSE.**—Pruning the trees must now be attended to. Full-grown trees regularly stopped during growth will require very little pruning. Any that have grown considerably should be cut back to about an inch from the base of the current year's growth, and the worn out or decayed spurs may be removed. The terminal shoots in the case of trees not full-sized must not be shortened unless the extremity of the trellis is reached, and the central shoot or shoots of young trees will require to be cut back as may be necessary to originate shoots for filling the space regularly. The fan mode of training is the most suitable, and is more particularly applicable to the Cherry, as it admits of replacing any branch that may fall a prey to gumming. The house should have a thorough cleansing, the trees being washed with soapy water (4 ozs. to a gallon is not too strong), and then dressed with a composition formed of half a pound softsoap to half a gallon of water, half a gallon of tobacco juice, with four parts flowers of sulphur and one part of slaked lime, so as to bring it to the consistency of thin paint, applying it with a brush, being careful not to injure the buds. The house must be thoroughly ventilated until the time arrives for starting the trees, and is better if the roof lights are off.

**PLUM HOUSE.**—Plums require the same temperature as Cherries. They also require similar treatment as regards pruning—i.e., all last year's growths will need shortening, superfluous shoots may be removed, avoiding having the shoots too thickly placed. Dishes of Plums are a welcome addition to the dessert. Early varieties should be chosen, as Early Favourite, July Green Gage, Early Transparent, Green Gage, Denniston's Superb, De Montfort, Jefferson, Transparent, and Kirke's, with Coe's Golden Drop if a long succession is required. It is best, however, to grow the early sorts in a house by themselves, and have the successions in another, so that the syringing necessary to keep the foliage clean may be pursued until the fruit commences ripening. The fan mode of training is the most suitable for the Plum. It is necessary that they have the roots restricted, as in wide, deep, and rich borders the trees grow too luxuriantly. Trees three or four years trained to a wall are the most suitable. Good loam, preferably rather strong, with a sixth of road scrapings and a tenth of old mortar rubbish thoroughly incorporated, form a suitable compost. If the loam be light add a sixth of clayey marl instead of the road scrapings. A depth of 2 feet, and a foot of drainage secured by a layer of old mortar rubbish, will suit Plums well, feeding by the surface.

**STRAWBERRIES IN POTS.**—The plants introduced to the vinery, Peach, or other forcing house should have the drainage scrutinised, making sure that it is free, and the loose surface soil removed, and a top dressing given of dried cow dung or horse droppings, rubbed fine

with the hands, adding about a twelfth part of bone dust or other approved fertiliser well incorporated, then watering it with a rose watering-pot, so as to bring into a moist state, for if placed on dry it washes off in watering the plants. The pots may then be placed in position after removing any decayed leaves, making sure that there is no deficiency of water at the roots, for the old leaves will not show signs of a deficiency of water until the soil is very much too dry for healthy root-action, therefore rap the pots; a practised hand will readily detect by the sound which plants are ceeding water. La Grosse Sucrée, Princess Frederick William, Vicomtesse Hericart de Thury, and Sir Harry are good varieties for early forcing.

#### PLANT HOUSES.

**Læta anceps.**—Where these plants are grown moderately warm they will be pushing up their flowers rapidly. A long time elapses before the flowers expand after the spike is first visible, and nothing is gained by hurrying them out. If kept gently advancing they are certain to produce large well coloured flowers of great substance. A portion of the stock may be retarded by keeping them in a temperature of 50° to 55°. Be careful not to give these plants too much water at their roots, and destroy apices directly they are seen; if allowed to establish themselves on the flower spike it will eventually turn yellow and fail to open its flowers. Do not allow the plants to be too near the glass while their spikes are developing, for if they nearly touch the glass they may be destroyed during a very cold night.

**Maxillaria picta.**—The sweet flowers of this variety are very useful in a cut state for small vases. Most of the stock may be removed to a cool house and kept dry, while one or two plants, according to their size, may be allowed to come into flower. By introducing a plant or two into heat at intervals of three weeks a long succession of these flowers may be had. After flowering the whole of the plants may occupy the warmest end of the Odontoglossum house until February. While in this position only give sufficient water to keep their pseudo-bulbs plump.

**Maxillaria grandiflora.**—This plant should have thoroughly matured its growth, and may be removed to an intermediate structure for two or three weeks, and then to the coolest house, in which it will rest thoroughly. Give water on the same principle as advised for *M. picta*.

**Lycaste Skinneri.**—All plants that have completed their growth may occupy the warmest part of the coolest house. They must be kept on the dry side, in fact give them no more water than is really needed to keep their pseudo-bulbs plump. Any plants that have not yet matured their growth may be kept in warmer quarters for a few weeks until they have done so.

**Odontoglossum Rossi majus.**—These have commenced unfolding their useful delicate flowers, and with a good stock of plants there is no difficulty in having flowers over a period of four or five months. To attain this end the latest of the plants must be retarded by placing them at the coolest end of the house. This variety will bear very cool treatment, in fact it will not be injured in the least if kept in any structure from which frost is excluded; however, it is not advisable to subject the plants to a lower temperature than 40°. While under these conditions do not allow them to hang too near the glass, and they must not be so moist at their roots as those that are kept in a house 5° to 10° warmer.

**The Odontoglossum House.**—Remove *O. vexillarium*, *O. Rozzi*, and *O. cirrhosum* from the Odontoglossum house to a night temperature of 55°; a temperature of 45° to 50° is too low for them. In a low temperature they go back, in fact often decay altogether. *O. cirrhosum* is one of the first to suffer, but under warmer treatment during the winter it will grow luxuriantly and increases its size rapidly. On severe occasions only should the temperature of the Odontoglossum house fall to 45°; on all mild occasions the plants will do better if the temperature ranges 10° higher, falling in the morning to 50°. At the warmest end of this house place *O. grande*, *O. Insleyi*, *O. citrosimum*, *Ada aurantiaca*, *Mesospidium sanguineum*, and allied plants, and then arrange *O. Alexandræ*, for even this popular variety will not bear with safety such a low temperature as *O. Pescatorei* and the varieties of *O. triumphans*; less moisture should be maintained both in the atmosphere and about the plants. By no means allow them to become dry or to suffer by an insufficient supply about their roots.

**Slugs.**—Where Odontoglossums are grown moderately warm to induce them to complete their growth and flower during the winter instead of spring, the flower spikes will from this date push up freely. Every attempt must be made to eradicate slugs, for they quickly devour a large number of spikes. If any exist in the house carefully protect the tender flower spike directly it is visible with cotton wool. Little pans with bran should be placed freely amongst the plants, and these examined two or three times during the evening. Lettuce leaves should also be freely laid amongst the pots, and carefully examined an hour or so after dark, and again about ten o'clock. Slugs are very fond of tender Lettuce leaves, and we generally succeed in catching more by this than any other means.

#### HARDY FRUIT GARDEN.

**COMMENCEMENT OF THE PRUNING SEASON.**—Much of the work of pruning and nailing wall trees as well as the pruning and training of the open garden trees ought to be completed before midwinter, advantage being taken of every fine and mild day to push the work forward. We usually commence with the Pears. The wall trees being of good size and full bearing order do not give much trouble. All leading growths where space has yet to be filled ought to be laid in to their full length, unless other side branches are needed, in which case they ought

to be freely shortened back. This part of the subject may, however, be reserved till the time has arrived for advising upon the treatment of young trees. If the lateral growth was lightly spurred back once or twice during the growing season they will now require to be finally shortened, or otherwise long ugly spurs will result, these being altogether out of place on wall trees. All young growths, whether previously shortened or not, should be cut cleanly back to near the second or third prominent bud or joint, this forming the nucleus of a cluster of fruiting spurs. By this time the fruit buds will be easily distinguished from the wood buds, the former being much the plumpest. It is frequently advisable to thin out and shorten large clusters of spurs, fruiting or otherwise, but it is those with a terminal wood bud that should be principally shortened, the aim being to keep the fruiting wood as near the walls as possible without sacrificing a portion of one season's crop. Trees with long ugly spurs should be gradually brought into a more desirable state. Thus one half of the old spurs may this season be neatly sawn off to within 1 inch of the main branches and the remainder next year. The trees being in fairly good health will push out a quantity of healthy lateral growths near where pruned, and these may soon be converted into clusters of fruit spurs. In many instances it is advisable next autumn to lift one half of the roots and relay into fresh loamy compost, the remainder being similarly treated the following year. In this manner what are now comparatively worthless trees may be changed to a most profitable condition, and capable of producing extra fine crops of fruit. If any of the wall trees are not worth cultivating, when the grafting season arrives cut all the main or side branches hard back and re-graft with a variety that is worthy of wall space. By no other method can a wall be so quickly refurnished with good bearing wood.

**PYRAMIDS, BUSHES, AND STANDARDS.**—These also may now be taken in hand with advantage, and it is these which are usually too freely pruned. They must be thinned, but in many instances it is unwise to shorten many of the leading branches. Wherever there is good space for a fresh branch leave the best placed lateral growth to its full length. If shortened in any way, even at the point, these young branches will push out a number of fresh shoots, but will form few or no fruit buds; whereas, if left to their full length next season, they will make very little wood growth, forming instead of this fruit buds at every joint. Not only are vigorous trees thus brought into good bearing order, but if lateral growths are left thinly all over shy-bearing or exhausted old trees, this soon has a re-invigorating effect on them. Some of our best fruit this season was gathered from what at one time were useless old trees. They were too old and too large to lift and replant, and had the simple experiment of clothing them with healthy young branches failed, re-grafting would have been resorted to. It must be understood that these were pyramidal and bush-shaped trees, and previously kept rather closely pruned. In the case of unpruned standards, these we would freely thin, leaving as many strong young growths all over the tree as possible. The saw as well as the pruning knife is necessary for the work, it being frequently advisable to cut out whole faggots of wood from neglected orchard trees. Crowded trees frequently produce large crops of fruit, but which are of little value, whereas those freely thinned yield heavy crops of fruit of a size and quality to command good prices if need be. We have seen large old standards freely cut in all over the tree, nothing but numerous short stumps being left. These push out a quantity of strong young shoots, which, if duly thinned and then left alone, soon arrive at a bearing state.

In the case of all healthy pyramidal and bush-shaped trees that have attained their full size—that is to say, have filled their allotted space, the leading shoots must necessarily be cut hard back, and all lateral growth be spurred in much as advised in the case of wall trees. If, however, there is yet plenty of room all round them, instead of shortening back the leading shoots, say to a length of 6 inches, under the impression that it is necessary to gradually build up these main branches, they are left their full length, good fruitful trees will be much more quickly grown, requiring little or no root-pruning to bring them into full bearing order. They may appear rather weakly at first, and perhaps offend the eye of the critical trainer, but this changes in time, and after all that is said or thought the ordinary consideration should be how best to quickly secure heavy crops of fruit. Those Pears on the Quince stock and Apples on the Paradise stock are not often likely to grow too vigorously, the reverse being the rule, not enough healthy growths being formed on them. Such trees are apt to grow unevenly, one side becoming stunted while the other grows strongly. These are the worse to deal with. The best remedy is to freely shorten the shoots on the vigorous portion of the tree now, and during next summer prevent them again taking the lead. This may induce a better growth on the stunted portion and prevent the formation of a one-sided tree. Stunted leading branches on wall trees are sometimes lightly shortened back and re-grafted with excellent effect, and the same plan might be adopted in the case of garden trees. Poverty at the roots may also have something to do with the uneven growth of these miniature trees, and those that are stunted especially ought to be replanted in fairly rich loamy compost. The least that can be done in the case of overworked trees is to bare the roots, covering them with a liberal dressing of short manure prior to returning the soil.

#### THE FLOWER GARDEN AND PLEASURE GROUND.

**Roses on their own Roots.**—In most gardens the most vigorous and floriferous Roses are the dwarfs on their own roots. At any rate, if these do not flower more freely than those on the Manetti and Briar stocks they are invariably the longest lived, being less liable to injury by frosts,

and seldom refuse to grow in almost any soil. Unfortunately they cannot be hought, and those who want them must perforce strike their own stock of plants. Nor is this a very difficult matter to accomplish, as if treated like Gooseberries and Currants they strike almost as readily. November and the early part of December is the best time for inserting the cuttings in the open ground, but they will root if the work of propagating is delayed till near pruning time, the cuttings in this case be disposed at the foot of a north wall. Our plan is to give up a good piece of open ground to the Rose cuttings, mixing plenty of road grit and a little manure with the soil, according as the cuttings are put in. Well ripened young wood is selected, these being first shortened into 1 foot lengths, then cleanly cut across at the lowest joint, rubbing off all thorns and shaving the lower buds at the same time. A trench 6 inches deep is then cut, and after a little road grit has been scattered along this the cuttings are inserted, and the soil is then firmly trod about them. Another trench is then cut, more cuttings put in, and so we proceed till the whole space is covered with several hundred cuttings. We dispose the rows 15 inches apart and the cuttings about 10 inches apart in the rows. On no account should the cuttings be kept out of the ground long after they are made, as should they once become dry a failure is bound to result. A surface mulching of leaf soil, spent tan, short manure, or ashes serves to check upheaval by frosts; but if in spite of this precaution frosts penetrate deeply it will be necessary, after it has left the ground, to well fix it about the cuttings again, as they will fail to strike if the soil is at all loose. Any that were struck last season, unless very weakly, may be safely transplanted to where they are to flower for some time. Lift carefully, saving as many roots as possible, and replant in well worked and fairly rich soil. Long straggling shoots ought to be shortened considerably, or otherwise they are caught by the wind, and wind waving is most injurious to newly planted Roses. Where newly rooted Roses are plentiful and cut flowers are in great demand it is a good plan to plant a number of them rather thickly, pruning them early next year and covering with garden frames. They will produce a quantity of useful blooms long before those in the open are plentiful.

## THE BEE-KEEPER.

### THE PURGATORIAL PROCESS FOR CURING FOUL BROOD.

At page 371 "A Hallamshire Bee-keeper" gives what he considers a new discovery for the cure of odourless foul brood, and at page 372 finds fault with the Editor of the *British Bee Journal* on some points in connection with the discovery of this disease. *Bacillus minor* was so named by the writer of "Useful Hints" in the *British Bee Journal* I do not doubt; but as his mode of cure known as the purgatorial process a quarter of a century since was fully described in the columns of this Journal by various writers, such as "A Renfrewshire Bee-keeper," and Mr. T. W. Woodbury and others, including myself, the process is certainly not new. At the same time it is the most satisfactory and profitable way of curing foul brood. I have not the numbers containing the successful reports of the cure of foul brood, but from 1862 onwards the most upon the subject will be seen. The idea of it being a congenital disease is not new either, as the answer to me upon the subject will be found in some of the numbers about the time mentioned. It was doubtless owing to some neglect of mine that these queens produced foul brood after often the treble-starving process. When prepared properly (and "A Hallamshire Bee-keeper" is near the mark with his description) I never knew a single case of failure, and I am of the opinion that it is a mistake to suppose any form of foul brood is congenital further than what germs may be introduced to her by the bees when feeding with the prepared pap. The rapidity with which these germs are produced when in a proper nidus is wonderful, and if a queen was affected with them to any extent, especially from birth, she would either not survive long or become sterile.

I have not seen a single foul brood cell in my apiary for many years, at least amongst my own stock, the disease disappearing after the introduction of a better

system of ventilation which has been often described. During the past summer, however, a disease of some sort, apparently akin to the odourless foul brood, appeared in a Syrian hive, but the diseased larvæ were never sealed over nor reached the pupa state; every one of them was cleaned out by the bees. Some of the grubs were odourless, while others had a most fetid odour. To such an extent was this hive diseased it made no increase in the number of its bees during the best of the summer. Owing to these bees cleaning out every offensive thing from their hive, I at first thought it was foul brood, but the cheesy nature of the dead grub changed my opinion, and I made an experiment by removing every comb, giving them to queenless bees, and under their nursing the disease ceased. Apparently every egg matured into a healthy bee, not even one cell being left unhatched. Meanwhile the Syrians were at work in their new hive, from which the disease seemed almost to have disappeared, as only an occasional grub was thrown out.

The only different treatment this hive had from the others was that it received a little Orange blossom honey from California. The bad effects arising from feeding bees with foreign honey is not a new discovery. Half a century since foreign honey was much cheaper than some sorts of inferior sugar which at that time could not be had for much less than 1s. per lb., and I remember it being sold at 1s. 2d. per lb. At that time bee-keepers did not attempt keeping many hives; but even with the few kept, when a bad season occurred it told heavily on the pockets of working men earning from 6s. to 9s. weekly. Knowing that the bee books at that time recommended honey as the best food for bees, many bee-keepers speculated in honey for feeding purposes, much to their dismay afterwards, for in every hive fed with it foul brood appeared. I believe that was not only the first but the last attempt to feed with foreign honey in this district.

When the late Mr. T. W. Woodbury's apiary was infested with foul brood, about 1861, he was driven to his wit's end for a cure. Some amusing letters appeared on the subject, such as "Jonas Jackson's," among other things advising that money should not be taken in return for bees, if it were misfortune was sure to follow. The German writers hinted that the cause of the disease would never be found but by learned scientists. Every writer had an opinion of his own as to the cause. "A Renfrewshire Bee-keeper" gave the "Purgatorial Process," as a cure, and Mr. Woodbury in a private letter revealed that the cause in his case was feeding his bees with foreign honey. Stifling and overheating is in my opinion the origin of foul brood in its worst form.

#### THE USE OF FERTILE WORKERS.

It will be remembered by many of the veteran bee-keepers how the late Mr. T. W. Woodbury exercised himself towards the discovery of anything mysterious concerning bees for their and their owner's interest. One of these things was what he then thought on queens laying eggs before fertilisation, and "A Renfrewshire Bee-keeper" saw in it something yet unrevealed to us to perpetuate the species at a critical period. I had numerous cases of eggs in a hive before the queen was fertilised, and which for a time I considered they were the eggs of the queen; but something occurred that changed my opinion, and in the early part of this year a beautiful example presented itself to me, confirming the change of my belief on so interesting a subject. On the 7th of March a queen was accidentally killed. A successor was

reigning about the 20th, and by the middle of April the hive was well filled with drone brood in all stages, too early to be the progeny of a well-matured and healthy queen, which in many cases remains in a virgin state for twelve weeks before fertilisation, when she lays worker eggs, or that time elapses with some queens unfertilised before she lays eggs that produce drones only.

Another examination of this hive was made about the middle of May, when, to the astonishment of all who witnessed it, worker brood was rapidly taking the place of what was occupied with drone brood so recently. The explanation of the above is, in my opinion, fertile workers are more often produced for the purpose of producing early, as they commence laying shortly after birth, while the drones of a sister bee are more distantly related to serve the queen than would be the drones of the queen, even should she be capable of mating after egg-laying had commenced, which I do not think could take place. Although some modern writers assert that drones, being the progeny of a fertile worker, are incapable of mating, it is a mistake; the drones of any fertile worker are as perfect in this respect as are any other, and numerous cases are on record of queens mating with the drones of fertile workers, and the above is but another instance of the same sort. At the time the queen would be fertilised no other drones would be on the wing, showing the utility of fertile workers, and the wise provision in Nature to perpetuate the species at a most critical time.—A LANARKSHIRE BEE-KEEPER.

#### ODOURLESS FOUL BROOD.

I NOTICE an article in the issue for November 10th, signed "The Writer of Useful Hints in the *British Bee Journal*, November 2nd, 1887," replying to my letter, and I see he also encloses copy of the article I had in my mind; for which I am obliged, as readers can see and judge for themselves. He says, "The entire responsibility, therefore, rests upon me, and I flatter myself that public opinion will acquit me of any desire to infringe upon what your correspondent claims as his own discovery." But we are not told who did write it.

In the *British Bee Journal* quotation it says, "Of this disease we have cognizance for some years, but always felt inclined to consider it incipient foul brood, which, if allowed to remain undisturbed, would end in the malignant *Bacillus Alvei*;" and in the last, "Our attempts at curative measures have always failed, although we have applied phenol, salicylic acid, &c." If we turn to the *British Bee Journal* for July 8th, 1886, page 302, under the head of "Useful Hints," we shall find the following:—

"In our district this evil has been very prevalent, in some cases leading on to foul brood. The queens, stimulated to egg-laying by syrup feeding, or the uncapping of comb honey, have produced more brood than the bees could well cover, while the speedy dwindling of the latter (caused sometimes by robbing as well as foraging) has left whole sheets of unsealed larvæ to perish and rot—a meet hotbed for the reception of bacilli, or foul brood germs. In several cases we have found five queens with distended ovaries, accompanied by about a dozen bees, on three or four frames of putrefying larvæ, without any of the odour, so well known to the practical expert, of foul brood. Is not this chilled brood often mistaken for foul brood?" Here we have the "odourless" form of foul brood very fairly described only about a year previously, yet there is not a word about its being a disease.

Mr. Raitt, in a footnote to my letter in the "Record," said he knew the disease I referred to, that it was not infectious but congenital, as he cured it by simply changing the queens. I have since sent him a sample, and he says it is the real foul brood, the only kind he has ever known as such; yet Mr. Cheshire says not, and he ought to know. No wonder Mr. Raitt directed everything to be burnt as the only cure, which unnecessary course prompted me to write him an article, pointing out that there were two forms of foul brood, and the one was incurable with physic.

Another point. It will be noted that the extract from the *British Bee Journal* of July last is now put forth to be judged on its merits. I am quite willing it should be so judged; but it is not always fair to judge by a single paragraph. Now, as a matter of fact, a very large portion of the columns of the *British Bee Journal* since July has been devoted to foul brood, and what they are pleased to call *Bacillus minor*. Never once am I mentioned, nor is there a hint that a way to cure it has been published, and, to crown all, in every contribution sent to them in which myself, my plans, or systems are mentioned the parts referred to are either left out, or the whole contribution rejected.—A HALLAMSHIRE BEE-KEEPER.





TO CORRESPONDENTS

All correspondence should be directed either to "THE EDITOR" or to "THE PUBLISHER." Letters addressed to Dr. Hogg or members of the staff often remain unopened unavoidably. We request that no one will write privately to any of our correspondents, as doing so subjects them to unjustifiable trouble and expense.

**Cyperus alternifolius (J. H. W.).**—Thanks for your notes. By all means try again. It is creditable for the first attempt, and you will improve with practice. It is an advantage to any man to be able to express his ideas lucidly, either in writing or speaking. Do not be in a hurry with the "ripening off" process, as you term it; secure a good development first.

**Expelling Worms from Pots (S. S.).**—Lime water we never knew fail to expel worms, provided the solution was strong enough and the hole in the pots stopped with clay, so as to thoroughly saturate the soil with the water. One pound of quicklime to three gallons of water, stirred well, allowed to stand forty-eight hours, and then used (*i.e.*, the clear lime-water) will expel or kill the worms, the pots being flooded for a few hours. It is safer than corrosive sublimate, which, however, is more effectual in expelling worms. If you use it be careful not to give too much.

**Pruning Vines (A. B.).**—Judging by the wood, which is stout and well ripened, the Vines will be capable of carrying a moderate crop of Grapes—say three to five bunches each, being guided as to number by the size of the bunches, not taking more than about 5 lbs. of Grapes from each Vine. The Vines should be pruned as soon as the leaves have fallen, cutting the canes back, so as to leave about 18 inches of good cane from the bottom of the rafter or trellis. Cover the outside border with a layer of leaves or short littery manure as a protection from frost. If leaves are used a little long litter over them will be necessary to prevent the leaves being blown about.

**Time to Plant Vines (F. A.).**—The Vines should be pruned or cut back now to the length required, and kept in the pots in a cool airy house with the soil rather dry until spring, which is the best time for planting Vines that have been allowed to become leafless. When they are commencing to grow is the proper time to plant, the roots being disentangled and spread out evenly before covering with soil, which should be pressed rather firmly about them, watering moderately after planting to settle the soil about the roots, using tepid water, and mulching with short material about a couple of inches thick.

**House for Tomatoes (Old Subscriber).**—The house would be a very suitable one for the growth of Tomatoes, the plants will do very well in the centre bed. They should not be planted too close, and nothing must be trained to the roof, or not high enough to shade them. The rows of Tomato plants must not be too close. You may have double rows—*i.e.*, 18 inches apart, leaving every third row out for convenience of attending to the plants. Your sketch shows no provision for ventilation. It will be necessary to have side ventilation. Hinged boards will answer very well running the whole length of the house, also top ventilation will be necessary the whole length of the house, preferably lantern fashion, an opening of not less than 1 foot wide. We consider Acme the best, but Hackwood Park is excellent, and for early use Earliest of All (Sutton's).

**Barbarossa and Alicante Grapes for Planting in the Same House with Black Hamburgs (W. A. P.).**—We have had the varieties named succeed fairly well with Black Hamburgs, but Barbarossa (Gros Guillaume) requires a much longer time to perfect its fruit, and for that reason is best grown in a house with others that require a longer season of growth than is necessary for Black Hamburgs. Alicante, not requiring so long a period, does fairly well in the same house as the latter; indeed, we had it this year in the same house in which it perfected well about three weeks after the Hamburgs. It forms a good succession to Black Hamburgs when grown in the same house. It is besides much better in quality than Gros Colman and some others of the class, the only recommendation of which is size. Alicante is the only Grape, except West's St. Peter's, that has the sprightliness of the Black Hamburg amongst thick-skinned Grapes, and it invariably colours well.

**Nutmeg Pippin (W. Paxton).**—The variety of which you speak so highly under the above name is Cackle's Pippin, and it is thus described in the "Fruit Manual":—"Fruit medium sized, conical or ovate, and slightly angular on the sides. Skin greenish yellow, changing as it ripens to deeper yellow, dotted with small grey dots, and covered all over the base with delicate pale brown russet. Eye small, and slightly closed, set in an irregular and somewhat angular basin. Stamens marginal or median; tube funnel-shaped. Stalk an inch long, rather slender, obliquely inserted in a round and deep cavity, which is lined with russet. Flesh yellowish, firm, tender, crisp, juicy, and sugary, with a pleasant aromatic flavour. Cells elliptical, axile, open. An excellent dessert Apple of the finest quality; in use from January to April. This was raised in Sussex by a person of the name of Cackle, and it is extensively grown in this as well as the adjoining county of Surrey. It is mentioned by Forsyth in a MS. memorandum book as a Sussex Apple."

**Apples and Plums for Market (W. R. S.).**—You will find Damsons profitable fruit, and we should plant those in the hedgerow, leaving the meadow for the standard Apples. The Farleigh or Crittenden and the Prune are the best Damsons for market. The new large Bulace is useful, coming in after the chief crop. Early Apples as standards will pay you best. Good showy Apples must be provided to suit the market, such as

Worcester Pearmain, Ecklinville Seedling, Lord Suffield, Cox's Pomona, Cellini, King of the Pippins, Small's Admirable, Stirling Castle, and Duchess of Oldburgh. If any of them succeed in your locality better than others you should plant those in quantity. You will, however, succeed much better on the cultivated ground. Plums and Apples succeed well together as dwarfs, the Apples on the Paradise stock. Plant in alternate rows 8 feet apart, with Gooseberries between, which pay well if gathered green. The following Apples do well as dwarfs, supplementing those enumerated above:—Irish Peach, Cox's Orange Pippin, Warner's King, Ribston Pippin, Dumelow's Seedling, Betty Geeson, and Mannington Pearmain. The last four are late varieties, but well worth growing. The following Plums do well as dwarfs:—Rivers' Early Prolific, Belle de Septembre, Prince Englebert, Prince of Wales, The Czar, Sultan, and Victoria, all of them being good for market. Early Prolific comes in before the market is glutted, and Belle de Septembre after.

**Culture of Vallota purpurea (R. S.).**—An experienced grower has described the following successful practice in these pages:—The compost employed should consist of turfy loam with a little decayed manure and leaf soil, with sufficient coarse sand to keep the soil open. In potting place three bulbs in a well-drained 6-inch pot; if bulbs are scarce have one in a 3-inch pot, but I recommend the former practice where possible, as the plants will flower profusely and make a beautiful display. In potting place some of the roughest of the compost over the drainage, then three parts fill the pots with soil, and press it down gently to prevent it sinking too much. If 6-inch pots are used place the bulbs a little distance apart to allow the growth of offsets. Tie the bulbs to a small stick to keep them steady, give a good watering through the rose of a watering can, and transfer the pots to the greenhouse, assigning them a position near the glass, and the bulbs will soon commence growing. Never permit them to be insufficiently supplied with water, and in the summer months they should be sprinkled overhead. When the pots are quite full of roots and the flower stems appearing weak guano water may be given twice a week. After flowering remove the flower stems, as they exhaust the bulb; the pots can then be placed in any sunny part of the greenhouse, so as to have the bulbs well ripened. The soil must not be allowed to become dust-dry at any time, not even in the winter months. The Vallota is increased by offsets. The small bulbs can be taken in the spring, and are either potted singly in small well-drained pots or placed in pans in a compost of half loam and leaf soil with a little sand, and if placed in a warm part of the greenhouse they will soon produce roots. To flower the plants well they must be rootbound, and three bulbs in a 6-inch pot will not require a larger pot for three or four years, providing the drainage is open.

**Ranunculuses (B. M.).**—The tubers may be safely stored in a mixture of sawdust and cocoa-nut fibre refuse, quite dry, or in dry sand. The best season for planting is in the early spring, as soon as the most severe frosts have passed and the ground has become tolerably dry. Some time about the end of February or the first week in March rake the surface of the bed in the morning of the day previous to that fixed upon for planting. Supposing, then, that the weather is propitious, and all things prepared, commence by drawing with a hoe a drill across the end of the bed 1½ inch deep; if deeper the roots will be weakened the succeeding year by forming a kind of stem near the surface; and if shallower, the plants are more liable to be struck with drought. The drill being drawn the right depth, plant the whole of No. 1, and press each tuber slightly down into the ground. Plant them, if large, 4 inches apart in the row; if small, 3½ inches will be a sufficient distance. Draw a second drill 5 inches from the first, and so on until the bed is finished. Cover the crowns of each tuber with fine sand. This will cause the tubers, when they are taken up in July, to come out of the ground quite clean for keeping. Then with a short-toothed rake draw the soil over the tubers, and when it is level, with the head of the rake gently press the soil pretty closely upon them. The soil should be retentive of moisture. The best kind is the virgin mould of some alluvial soil on the banks of a river or some lowland pasture. It should be of a rather close texture, without any small stones or sand amongst it. If the situation is low, with a wet subsoil, it must be well drained; but if the subsoil is dry there is no necessity for drainage. If the soil should be thought too poor a small addition of decayed cowdung will be advisable, but it must be so decomposed as to appear like a black powder. Let it be thoroughly mixed with the soil at the present time, and again forked over in the spring before planting.

**Names of Fruits.**—The names and addresses of senders of fruit to be named must in all cases be enclosed with the specimens, whether letters referring to the fruit are sent by post or not. The names are not necessarily required for publication, initials sufficing for that. Only six specimens can be named at once, and any beyond that number cannot be preserved. (W. A. K.).—1, Certainly not Newtown Pippin, merely a wildling; 2, Carl Tail; 3, Brabant Bellefleur; 4, Pinner Seedling; 5, Cellini; 6, Leather Coat. (W. R.).—1, White Nonpareil; 2, Golden Pearmain; 3, Hughes' Golden Pippin; 4, Fearn's Pippin; 5, Court of Wick; 6, King of the Pippins.

COVENT GARDEN MARKET.—NOVEMBER 30TH.

MARKET still very dull. Large supplies of Canadian Apples to hand.

PLANTS IN POTS.

	s.	d.	s.	d.	s.	d.	s.	d.
Aralia Sieboldi, dozen	8	0	12	0	Fuchsia, dozen	0	0	0
Arborvitae (golden), dozen	6	0	9	0	Geranium (Ivy), dozen	0	0	0
(common), dozen	0	0	0	0	"    Tricolor, dozen	0	0	0
Asters, dozen pots	0	0	0	0	Hydrangea, dozen	0	0	0
Azalea, dozen	0	0	0	0	Lilies Valley, dozen	0	0	0
Begonias, dozen	4	0	9	0	Lilium lancifolium, doz.	0	0	0
Capsicums, dozen	0	0	0	0	"    longiflorum, doz.	0	0	0
Chrysanthemums, dozen	4	0	12	0	Marguerite Daisy, dozen	6	0	12
Cineraria, dozen	0	0	0	0	Mignonette, dozen	0	0	0
Dracena terminalis, doz.	30	0	60	0	Musk, dozen	0	0	0
"    viridis, dozen	13	0	24	0	Myrtles, dozen	6	0	12
Erica, various, dozen	9	0	18	0	Palms, in var., each	2	6	21
Euonymus, in var., dozen	6	0	18	0	Pelargoniums, dozen	0	0	0
Evergreens, in var., dozen	6	0	24	0	"    scarlet, doz.	3	0	9
Ferns, in variety, dozen	4	0	18	0	Poinsettia, dozen	0	12	15
Ficus elastica, each	1	6	7	0	Solanum, dozen	9	0	12
Foliage Plants, var., each	2	0	10	0	Spiraea, dozen	0	0	0

CUT FLOWERS.

	s. d.	s. d.		s. d.	s. d.
Abutilons, 12 bunches ..	3	0 to 6	Lillies, White, 12 bunches	0	0 to 0
Anemones, 12 bunches ..	0	0	,, Orange, 12 bunches	0	0 to 0
Arum Lillies, 12 blooms ..	5	0	Lily of the Valley, 12		
Asters, 12 bunches ..	0	0	sprays .. .. .	6	0
,, French, bunch ..	0	0	Marguerites, 12 bunches	2	0
Bouvardias, bunch ..	0	8	Mignonette, 12 bunches	3	0
Camellias, blooms ..	2	0	Myosotis, 12 bunches ..	0	0
Carnations, 12 blooms ..	1	0	Pansies, 12 bunches ..	0	0
,, 12 bunches ..	0	0	Pelargoniums, 12 trusses	0	9
Chrysanthemums, 12 hchs.	6	0	,, scarlet, 12 trusses	0	4
,, 12 blooms	0	8	Poinsettia, 12 blooms ..	4	0
Cornflower, 12 bunches ..	0	0	Primula (single), bunch ..	0	0
Dahlia, 12 bunches ..	0	0	,, (double), bunch ..	0	9
Daisies, 12 bunches ..	2	0	Polyanthus, 12 bunches ..	0	0
Encubis, dozen ..	4	0	Rannunculus, 12 bunches	0	0
Gardenias, 12 blooms ..	2	0	Roses, 12 bunches ..	0	0
Gladiolus, 12 sprays ..	0	0	,, (indoor), dozen ..	1	0
Hyacinths, Roman, 12			,, Tea, dozen ..	1	6
sprays ..	0	6	red, dozen (French)	1	6
Iris, 12 bunches ..	0	0	yellow .. .. .	3	0
Lapageria, white, 12			Stephanotis, 12 sprays ..	4	0
blooms ..	1	6	Tropeolum, 12 bunches	0	0
Lapageria, coloured, 12			Tuberose, 12 blooms ..	0	6
blooms ..	1	0	Tulips, dozen blooms ..	0	0
Lilium longiflorum, 12			Violets, 12 bunches ..	1	0
blooms ..	6	0	,, (French), bunch	1	6
Lilium lancifolium, 12			,, (Parne), bunch	3	0
blooms ..	0	0	White Lilac, 12 sprays ..	6	0

VEGETABLES.

	s. d.	s. d.		s. d.	s. d.
Articokes, dozen ..	1	0 to 2	Lettuce, dozen ..	0	9 to 0
Asparagus, bundle ..	0	0	Mushrooms, punnet	0	6
Beans, Kidney, per lb. ..	0	3	Mustard and Cress, punt.	0	2
Beet, Red, dozen ..	1	0	Onions, bunch ..	0	3
Broccoli, bundle ..	0	0	Parsley, dozen bunches	2	0
Brussels Sprouts, 1/2 sieve	3	6	Parsnips, dozen ..	1	0
Cabbage, dozen ..	1	6	Potatoes, per cwt. ...	4	0
Capsicums, per 100 ..	1	8	,, Kidney, per cwt.	4	0
Carrots, bunch ..	0	4	Rhubarb, bundle ..	0	2
Cauliflowers, dozen ..	3	0	Salsafy, bundle ..	1	0
Celery, bundle ..	1	8	Scorzoner, bundle ..	1	8
Coleworts, doz. bunches	2	0	Seakale, basket ..	1	6
Cucumbers, each ..	0	4	Shallots, per lb. ..	0	3
Endive, dozen ..	1	0	Spinach, bushel ..	1	6
Herbs, bunch ..	0	2	Tomatoes, per lb. ..	0	4
Leeks, bunch ..	0	8	Turnips, bunch ..	0	4

FRUIT.

	s. d.	s. d.		s. d.	s. d.
Apples, 1/2 sieve ..	1	6 to 8	Oranges, per 100 ..	6	0 to 12
Nova Scotia and			Peaches, dozen ..	2	0
Canada barrel 10	0	18	Pears, dozen ..	1	0
Cherries, 1/2 sieve ..	0	0	Pine Apples, English,		
Cobs, 100 lbs. ..	55	0	per lb. .. .. .	1	6
Figs, dozen ..	0	0	Plums, 1/2 sieve ..	0	6
Grapes, per lb. ..	0	8	St. Michael Pines, each	3	0
Lemons, case ..	10	0	Strawberries, per lb.	0	0
Melon, each ..	0	6			



PROGRESS.

In experimental agriculture we find the most remarkable evidence of progress; we ought perhaps to say in the results of such experiments, for they are certainly both numerous and remarkable enough. It is in them that we find expression given to the general feeling that improvement in practical farming is possible. Of course attempts are made to oppose and discourage such efforts at improvement. That sort of thing is inevitable, and we need not trouble our heads about it; our best justification being found in results which are gradually bringing about a radical change in agriculture, not simply in one, but in every branch of it.

When Professor Jamieson showed in his manure circular that for an acre of Mangolds we should use, in addition to 14 tons of farmyard manure, 3/4 cwt. nitrate of potash, 1 1/4 cwt. nitrate of soda, 2 cwt. steamed bone flour, 1 cwt. ground coprolite, and 1 cwt. common salt, at a cash price for the chemical manures of 43s., there was an outcry about the extravagance of such a costly mixture; yet it was well known by those farmers who had used his manures that, other things being equal, the manures would ensure a splendid and profitable crop. We are told in "The Land Agent's Record" of November

12th that "some crops do pay very well indeed, even in these bad times. Mr. S. Sherwood took the first prize at the Framlingham (Suffolk) Farmers' Club last week for the best 3 acres of Mangolds with a crop which weighed 45 tons per acre. It was obtained by the application of from twenty-five to thirty loads of muck per acre, with 4 cwt. kainit, 4 cwt. basic slag, 1 1/2 cwt. of nitrate of soda, and 28s. worth of fish manure per acre; the whole costing not less than £6 10s. per acre. The result, however, wholly justified the expenditure, as the crop is a very fine one for so unfavourable a season as the present, and its value per acre must far exceed any corn crop, even when a full allowance is made for the straw." We gladly quote this striking example of liberal and judicious expenditure, which, instead of proving a piece of extravagance, was the embodiment of sound practical economy.

Turn where we will, on every hand we find earnest energetic men striving for improvement without counting the cost of time, labour, and money, all which is given freely for the general good. Experiments upon Barley, Roots, and Grasses have been conducted this year by the Norfolk Chamber of Agriculture in connection with the Royal Agricultural Society of England, upon the farms of Mr. Taylor at Whitlingham, Mr. Sapwell of Aylsham, and Mr. Cooke at Flitcham Abbey. The results will be published at the end of the year, but we may mention that it was our privilege to meet the Committee and inspect the trial stations at Mr. Garrett Taylor's farm on July 30th, and we were most favourably impressed by what we saw. Certainly, we gained important information, to be turned to account in our own practice, and we hope to give our readers a full account of the experiments and the results in time to be of use to them for another season.

In the new number of the Journal of the Royal Agricultural Society we have an exhaustive report of sheep-feeding experiments conducted at Woburn last winter by Dr. Voelcker, by which it was proved that the most profitable food for fattening sheep is decorticated cotton cake, and that next to it is Wheat—ergo, as we have not to purchase the Wheat it must be the most profitable food for a farmer to use. At any rate, that is how we apply the lesson, for we greatly deplore the low prices obtained for Wheat, and the large sums spent on cake of one sort or another.

Then we have an equally exhaustive account of field experiments on cattle Cabbages at Horsham, by which it is shown that the most efficient dressing used was one of phosphates with 2 cwt. of nitrate of soda and 3 cwt. of salt per acre, which produced 8 tons 7 cwt. extra Cabbages at a cost of £2 4s., or about 5s. per ton of additional Cabbages. From the results obtained growers of Cabbages are recommended to use as an artificial dressing at seed time 4 cwt. of superphosphate per acre, if the soil is fairly calcareous, or, if not, to use 3 cwt. of superphosphate mixed with 1 cwt. of bone meal, ground coprolite, or other finely ground phosphate top-dressing, after singling out, with 2 cwt. nitrate of soda per acre, mixed with 3 cwt. of salt.

Knowing as we do that many of our readers have no opportunity of seeing such reports, we strive by giving them particulars of results to keep them posted in the latest doings of pioneers in the work of improvement, in order that they may keep abreast of the times, and turn to account every real improvement in agriculture as soon as possible after it is made public. The experiments are conducted so carefully, and are so exhaustive, that we have full reason to place entire reliance in, and to take action upon results.

WORK ON THE HOME FARM.

Much time has been taken up in earthing corn sold at recent markets. We have had to push on corn threshing at one or two farms which have been in hand and were let at Michaelmas. Under our covenants the incoming tenant has to thresh, clean, and deliver corn left on the farm, and he has the straw for so doing; but we find that a new tenant has so much upon his hands at the outset that it hardly answers to hold him strictly to such a bargain. It is his interest to see to the ploughing and sowing of winter corn: it is ours to see that no corn stacks suffer by exposure to deprivations of any kind, and experience has shown that there is some risk of this. We had one large Wheat stack so left, from the bottom of which the straw was pulled so badly by a flock of geese that there was a considerable degree of risk that it would topple over. The mischief was done in some three or four days, and we should not have thought it possible that geese could have pulled out long Wheat straw in such a manner. The moral of this is never to leave a corn stack without a fence of hurdles well set around it. It is a good rule so to enclose every stack, if there is not a close, strong fence around the rick-yard, for it is a common sight to see hay and Clover stacks with the sides much pulled about by stray cattle. Corn markets fluctuate at times in a curious manner for which it is difficult to account. Last market we had several samples of Barley on offer, and were able to dispose of all of them at fair rates, except one which we regarded as exceptionally good, for it was a full, heavy sample, thin-skinned, bright, and quite unstained by any exposure to weather. "No," said one merchant after another, "we don't want white Barley," and we could not sell. Yet this is the very class of Barley which last season would command an exceptionally high price.

Winter corn is a full, strong plant; Wheat, Rye, Beans, and Oats all having a flourishing, healthy appearance. Since our serious losses among the Bean plant last winter we have come to regard this crop as somewhat speculative. The losses were owing to the exceptional severity of the weather, which caused the stem to perish just upon the surface of the soil. In this matter we are very much at the mercy of the weather. We have, however, had the Beans sown by plough drills, so as to leave the surface rough and uneven, in order to afford the plant some slight protection from cold, cutting wind.

THE WHEAT CROP OF 1887.

THE very low prices during the last few years have, it is supposed induced farmers to use a not inconsiderable quantity of their Wheat as food for stock. The amount so withdrawn from human consumption is quite unknown. It has been estimated by some to be considerably less than one million, and by others to be even as much as two million quarters within the harvest year. Whatever the amount may be, it is evident that a new element of uncertainty is thus introduced into our estimates of the quantity of imported Wheat required to supply the deficiency of the home-grown crop.

The "Agricultural Produce Statistics" published at the beginning of the year give, as the result of inquiries in 14,000 parishes in Great Britain, and many in Ireland, an average yield of 26.89 bushels per acre for the Wheat crop of the United Kingdom in 1886. If we deduct from this amount 2½ bushels per acre for seed, as we did in the case of our own estimate, it leaves only 7¼ million quarters available for consumption by the population and for stock feeding. The imports less exports for the harvest year ending August 31st, 1887, amounted to 17½ million quarters, making altogether a total of little over 24½ million quarters. But assuming the consumption per head of the population to be 5.65 bushels, which is the figure we have adopted for the last ten years, the amount so required would, independently of the quantity consumed by stock, be 26½ million quarters, or two million quarters more than the estimated available home produce and imports taken together. By the kindness of Messrs. Beerbohm I have been furnished with a statement of the amount of Wheat, and of flour reckoned as Wheat, in warehouse on July 1st, 1886, and July 1st, 1887, from which it appears that the stocks were slightly the higher in 1887, whilst it is estimated that subsequently to that date they somewhat increased.

Our own estimate of the yield of the Wheat crop of 1886 was 29¼ bushels. This is considerably higher than that of the Government above quoted; and it is also higher than the estimates of others. According to our figure, the available supply of home produce was nearly 8 million quarters. Even with our higher estimate of the home crop there is still a deficiency in the imports for the estimated requirements for human consumption, to say nothing of the amount consumed by stock. The evidence so far would thus seem to suggest the question whether there has not been some decline in the consumption per head of the population. At the same time it should be stated that if we take our own estimates of the available home produce and the recorded imports for the whole period of the eleven harvest years 1876-77 to 1886-87 inclusive, for which we have adopted a consumption of 5.65 bushels per head, the result shows precisely that amount available, if no allowance be made for consumption by stock. It is obviously desirable, however, that those who are engaged in forming the estimates of the yield of the Wheat crop should also endeavour to ascertain the facts as to the quantity of Wheat consumed by stock.

The Rothamsted result of 28¾ bushels, which more probably under than overstates the crop of the country, if calculated upon the slightly increased area this year—namely, 2,383,584 acres—gives an aggregate produce for the United Kingdom of 8,454,275 quarters. Hitherto we have always deducted 2½ bushels per acre for seed, but this is supposed to be too high an average at the present time, and if we deduct only 2 bushels, there remain 7,858,379, or rather less than 8 million quarters available for consumption. Still, estimating the consumption per head of the population at 5.65 bushels, the requirement for the harvest year would be 26,419,940, or nearly 26½ million quarters, of which about 18½ million quarters would have to be supplied by stocks and imports.

For some reason the imports of Wheat have been below the estimated requirements for the last two years. Whether or to what extent this is due to previous accumulations, to the home crops having been underrated, or to a reduction in the consumption of bread and flour, there is not sufficient evidence to decide conclusively. If there has been a reduced consumption, the question arises whether there has been an increased consumption of other foods. During the last few years there has been some increase in the number of both cows and other cattle kept, but there has upon the whole been a reduction in the number of both sheep and pigs. In fact, the records, neither of the home production nor of the imports of animal foods, afford evidence of any material increase in the consumption per head of such foods.

Further, a careful examination of the amounts of the imports of other articles used as human food shows in the aggregate a reduction rather than an increase in proportion to the population. In such articles as Rice and Potatoes, for example, which would to some extent substitute Wheat, the decline in the imports is very marked. Thus, while during the five years 1877-81 the average annual imports of Potatoes amounted to 393,277 tons, during the five years 1882-86 they amounted to only 156,017 tons, or to considerably less than one-half. Nor is it probable that the amount of Maize flour used has at all materially affected the consumption of Wheat. The indication would thus seem to be, therefore, that if the consumption of Wheat has really declined, either the total consumption of food per head of the population has also declined, or that the deficiency in the Wheat imports has been compensated by increased supplies of home-grown foods. So far as Potatoes are concerned, however, the "Agricultural Produce Statistics" show a decline in area, in produce per acre, and in aggregate produce, both in 1885 and in 1886 compared with 1884. On the other hand, there has, notwithstanding an increase in the imports of other vegetables, been a considerable increase in the area of allotment gardens. It would obviously be a ground of satisfaction should further information and consideration show that, notwithstanding the very low prices of grain, there has been a larger consumption of some other home-produced foods.

Whilst it is obviously of importance to the grower that his Wheat crop should yield well, it has ceased to be a question of any interest to the consumer whether the yield of the home crop is a few bushels per acre more or less. Nor does such a difference on our much reduced area at all materially affect the supply from foreign sources. During the eight harvest years 1852-53 to 1859-60, which were the first of our estimates of the home Wheat crop, nearly three-fourths of the aggregate amount consumed was of home growth, and little more than one-fourth was derived from foreign sources; but during the eight years 1878-79 to 1885-86 little more than one-third has been provided by the home crop, and nearly two-thirds by imports; and were it not for the value of the straw for hedging purposes it is probable that the reduction in the area under the crop would have been even greater than has actually been the case.

Although greater facilities for acquiring land have been afforded by the Acts of Parliament recently passed, there is not much probability that the result will be an increase in the area under Wheat or other grain crops; or, in fact, that tillage on a small scale will successfully compete with arable farming as at present practised. Nor is it likely that there will be any permanent extension of peasant holdings of pasture land, excepting in localities where the soil and climate are specially favourable for permanent grass. But garden allotments, as distinguished from peasant holdings or from farm allotments, are of very great advantage to the masses of the population, and will no doubt continue to extend as they have done largely during the last quarter of a century.—SIR J. B. LAWES (*in Nature*).

OUR LETTER BOX.

Distinguishing the Sex of Guinea Fowls (*W. S.*).—The sex is somewhat difficult to distinguish. One mark is the cry, the hen alone uttering the peculiar note which nearly everybody compares to the words "Come back," uttered in a shrill tone. Cocks may also be distinguished by the arching of their backs, and running along on tiptoe with a mincing air. They are also more spiteful than the hens to other poultry. Another mark is that the wattles of the male are larger than those of the female, and rather differently placed.

METEOROLOGICAL OBSERVATIONS.

CAMDEN SQUARE, LONDON.

Lat. 51° 32' 40" N.; Long. 0° 8' 0" W.; Altitude, 111 feet.

DATE.	9 A.M.					IN THE DAY.				Rain	
	Baromet- er at 32" and Sea Level.	Hygrome- ter.		Direction of Wind.	Temp. of soil at 1 foot.	Shade Tem- perature.		Radiation Temperature.			
		Dry.	Wet.			Max.	Min.	In sun.	On grass		
1887.											
November.											
Sunday .....	20	29.567	35.8	35.0	N.E.	38.8	38.8	31.1	51.2	24.6	—
Monday .....	21	29.593	33.4	33.4	Calm	38.4	38.7	31.6	40.2	32.4	0.079
Tuesday .....	22	29.701	38.2	38.2	N.E.	38.5	33.3	30.9	47.6	31.6	0.152
Wednesday .....	23	29.930	39.3	38.0	N.	39.2	43.1	37.9	67.8	37.1	—
Thursday .....	24	29.917	34.3	35.1	N.	39.3	39.8	32.5	40.8	27.4	—
Friday .....	25	29.736	33.2	37.1	S.W.	39.2	48.6	33.1	58.1	29.1	—
Saturday .....	26	29.797	48.2	44.7	W.	39.3	52.1	37.9	58.6	30.7	0.018
		29.756	38.5	37.4	—	39.0	43.5	33.5	52.0	30.4	0.249

REMARKS.

20th.—Rain in small hours; cold damp fog all day.  
 21st.—Cold damp fog all day.  
 22nd.—Rain in small hours; dull, damp morning, but warmer; fine afternoon; heavy shower 5 to 6 P.M.; dull evening.  
 23rd.—Fine, with a good deal of sunshine; bright night.  
 24th.—Dull early, spots of rain about 10 A.M., then fair; overcast afternoon.  
 25th.—Fine and bright, but slightly foggy at times.  
 26th.—Fine and warm, but not bright.  
 A variable week, with two or three pleasant days a little marred by slight fog. Temperature variable, and though 5° above that of the preceding week about 5° below the average.—G. J. SYMONS.





# COMING EVENTS

8	TH	The National Rose Society's Annual Meeting and Dinner.
9	F	
10	S	
11	SUN	3RD SUNDAY IN ADVENT.
12	M	[ of Fellows.
13	TU	Royal Horticultural Society—Committees at 11 A.M. Special Meeting
14	W	

## THE SCIENCE OF CHRYSANTHEMUM JUDGING.

**A**S Science has been authoritatively described as "knowledge grounded on demonstration and self-evident principles capable of being reduced to practice," the method that will be described of judging blooms of Chrysanthemums when placed in competition may fairly claim to come within the definition.

The term, however, is mainly employed as indicating a sharp distinction between the looser plan of judging by guesswork. Mr. Lewis Castle, who knows Chrysanthemums and how to judge them, referred approvingly in his notes on page 471 last week to my method of recording the merits of blooms in competing stands. That system is published in Mr. Molyneux's book, and has, I know, been described as fanciful and complex. To that I have not the slightest objection, as it is only in accordance with custom to so regard anything as an innovation, or what is a departure from time-honoured customs. It is well that this should be so, or we might be inundated with plans and schemes having little more than mere novelty to recommend them. Experience alone can prove the value or defects of new methods, and though I did not lightly, nor without many trials of its working, advance the plan of expressing the merits of blooms in two denominators instead of one where "point" judging is resorted to, I am now fortified by the experience of others during the late campaign that the plan, instead of being fanciful, is severely practical, and so far from being complex its simplicity becomes apparent in a moment to persons who have not previously seen it carried out.

There are a few persons who judge Chrysanthemums occasionally that feel quite competent to determine the awards in close competition without having recourse to "pointing," or examining the blooms individually and recording the merits of each by a figure or figures. Such individuals are extraordinarily good guessers if they can decide accurately when three or four stands of forty-eight blooms are arranged, half of each being incurved and the other Japanese, and one kind taking the lead in one stand and the opposite kind in another. I have acted with the majority of good judges from time to time, and am bound to say I have not found one who could have arrived at a true decision in a Sheffield class, for instance, in which Mr. Mease and Mr. Midgley staged so closely. There was no difficulty in guessing that Mr. Mease had the best incurved blooms and Mr. Midgley the best Japanese, but I cannot conceive it possible that the relative value of the whole could be determined except by the most careful enumeration of the merits of the forty-eight blooms in the two stands. A decision could have been arrived at without the so-called "trouble" of pointing,

but it would have been just as likely to have been wrong as right. Here is the result:—

MR. MEASE.		MR. MIDGLEY.	
Incurved.....	108+3	Incurved.....	102+3
Japanese.....	110+9	Japanese.....	111+3
	<u>219   0</u>		<u>215   6</u>

Thus, Mr. Mease won by 2.6, or 2½ points only out of a possible 288—six points being taken as the standard of a perfect bloom. As will be seen, he gained six points by his incurved and lost 3½ by his Japanese, and the difference between the gain and the loss represents the small majority named. The stands were examined by many good Chrysanthemum growers before the awards were made, and no agreement could be arrived at as to which was the better, but after the verdict was given as the result of such close scrutiny no one questioned its accuracy. There was a general impression perhaps that Mr. Parker's blooms would win the first position, and they did, but opinions were about equally divided as regards the others, as well they might, and the best of guessers could not have given a verdict the accuracy of which could be demonstrated, and hence meet with general acceptance. The difficulty is often greater in adjudging the second and third prizes than determining the first; but obviously the same care is needed in awarding the third as the first, or justice would not be done to all the competitors.

There was closer running between two similar stands at Liverpool, and it was closer still between two stands of incurved blooms at Putney, only 0.3, or ¼ of a point dividing them. If anyone should say or think that this is drawing the line too fine my reply is, If I owe the objector 3d. he is as much entitled to it as he would be to 1s. if that were the amount due. Book-keeping is reduced to a science because of the accuracy that is essential, and it would be clumsy work if no account were taken of the pence column in the ledger, or if no such column were prepared; and this brings me to the method of judging Chrysanthemum blooms that is so simple in action, while it is the most certain I have found in extremely close competition.

For the purpose of enabling it to be understood at a glance and carried out easily by anyone who has a knowledge of the different varieties, their character and capacities, it is worked on the shillings and pence system, "points" being entered in the shilling column and the margins of merit between them in the column for pence. A point is divided into parts, representing ¼, ½, or ¾ of the whole, and entered as 3d., 6d., and 9d. respectively. It would be easy to still further subdivide, but more minute divisions as representing the merits of blooms would not be so readily determinable. The desiderata are accuracy with simplicity, and these are provided, as may be seen by an illustrative case. Let us take the back row of blooms in a stand of twenty-four incurved varieties—Mr. Parker's at Sheffield—and show their value:—

	s.	d.
1 Lord Alcester .....	5	6
2 Jeanne d'Arc .....	5	6
3 Lord Alcester .....	5	0
4 Queen of England .....	5	3
5 Empress of India .....	4	3
6 Queen of England .....	5	6
7 Empress of India .....	4	6
8 John Salter .....	4	9
	<u>40</u>	<u>3</u>

In adding up the pence column we have a total of thirty-nine, or 3s. 3d.; the 3d. is put down and the 3s. added

in the other column, bringing the total to 40s. 3d., or 40½ points. What could be simpler? And what would have been the probable result if the points had not been divided? As there was not a bloom in the row or in the show considered perfect in all points—size, depth, symmetry, solidity, breadth of petal, freshness or colour—the total would, in all likelihood, have been thirty-eight (as the last bloom would no doubt have counted five), or a loss of 2½ points. It may be said, however, and with some degree of plausibility, that the loss would have been in the same proportion in the back rows of competing stands, so the result would still be fair to all. But that is not invariably so, as I find in corresponding rows in two stands one gains four points in the second column, while the other only gains 1½; indeed, from an examination of the recorded value of upwards of 800 blooms before me, arrived at on the system advocated, I am more than ever convinced of the soundness of the proposition that “in all cases in which the relative merits of competing stands are not clearly shown by one denominator two should be resorted to, and then the chance of a mistake would be reduced to a minimum.”

As evidence that that ¼ point is determinable and not without effect, a circumstance may be alluded to as occurring at Sheffield. After the classes were finished the best bloom in the Show had to be found, incurved or Japanese. After a rigid search the honour was accorded to a fine Queen of England in Mr. Mease's 48-stand. On subsequently looking through the points of 144 blooms in the class, this was the only one credited with 5·9 or 5¾ points, so that the ¼ point told sufficiently to win the National Society's certificate, which was the prize in question. There were several 5½ point blooms, and few below 4 points, so that practically, in good competition, there are only 4 points to work from 3, 4, 5 and 6, which renders subdivision the more necessary in accurately gauging the merits of the blooms. Nor does the two-denominator system take up more time than one, but rather takes less, and for this reason. Look at the list above given. The Judges examine No. 1, it is not perfect, and they hesitate whether to do it a little more than justice by giving it 6 points or a little less by only entering 5. Suggest half a point and they decide in a moment, 5·6 being jotted down. No. 2 is seen at a glance to be of the same value, and is entered accordingly. No. 3 falls a little short of No. 1 (the same variety), and is quickly debited with half a point less. No. 5 falls a point. No. 6 rises again, being equal to No. 2. No. 7 comes down, but is a trifle better than No. 5 (the same variety), and No. 8 is appreciably better than No. 7, and gets ¼ point more because it deserves it, the whole being completed in less time than in writing these lines, and in less time also than would be consumed during the pauses in determining on full points in each case, while there can be no question as to which plan is the more accurate.

Do not let it be supposed that pointing is advocated throughout a show. Nothing of the kind is suggested. It would be altogether superfluous in the vast majority of cases, and a waste of time. It is only in large classes and close competition when it is necessary to resort to the plan; it should then be adopted without hesitation, conducted with the utmost care, and completed in the best possible manner. Much time is often lost by judges marching backwards and forwards, and sometimes getting more or less bewildered, then after all having to resort to figures. It is better to begin at the outset in cases of doubt in large classes. Pointing was not called for this year in the chief contests at Kingston, the Crystal

Palace, Hull, and the Veitch Memorial class at Liverpool, but was absolutely essential at the “National,” Portsmouth, Sheffield, another great class at Liverpool, Putney, and some other shows. As slight evidence that I have no “weakness” on the matter, I have shared in judging at the least 500 stands of blooms this year, and pointed less than twenty, but the majority were forty-eights, and composed of half Japanese. Stands of twelve blooms and less can usually be judged by comparison, as can the majority of eighteens and twenty-fours; but not all, as in the Putney contest. Space precludes giving particulars of this here, but something will perhaps be said about it in the forthcoming “Chrysanthemum Annual.”

Judging by a general and, so to say, unsystematic inspection, of large mixed stands of nearly equal merit is not a safe course to adopt, for two reasons—1, the “chance” of deciding wrongly; 2, the absence of material for showing the accuracy of the awards in meeting a possible protest. As has been stated in referring to the unfortunate Hull case last year, the protest was lodged on the ground that judging was not done by points; and, assuredly, if it had not been, all the work would have had to be done over again on the pointing system, and what that involves in a crowded hall no one knows only those who have experienced the difficulty. Let it be said in reference to the losing stands on that occasion that they contained splendid blooms beautifully set up. The first prize blooms were staged too low for creating a favourable impression at the first glance. They were in fact rather better than they looked, while the others looked rather better than they were; and therein, I suspect, lurks the sequel of the whole affair. The second prize stands did “look” better than the first, and in case of an equality of pointing would no doubt have had the casting vote in favour of superior staging; but no one, I presume, would place this higher in merit than superior cultivation. It is not suggested that the winning blooms were badly staged, for they were not; they were somewhat low, and the exhibitor has staged a trifle higher this year, his stands having consequently a more imposing appearance. The blooms were subjected to close individual examination, and only in that way could their true merits be ascertained.

In these days of close competition the flowers should be represented to the best possible advantage, for though experienced judges will find their value, there is the possibility in close contests of losing points for faulty staging, and thus losing prizes. Exhibitors should never forget that judges look for faults, and sometimes are glad to find one or two to justify them in their decision. Occasionally a stand is found in the south in which the blooms are staged rather too high, giving them a stiff or stilted appearance; but we do not find this in the north, the fault there tending in the other direction, and is often very apparent in the amateur classes.

Reverting to the process of judging, so long as the intrinsic merits of blooms are held in the highest regard the point system must be resorted to in large mixed classes and close competition, and when this is very keen indeed it seems to me that the points must be divided, so that the smallest gradation in merit can be recorded. The method described has been tested by Mr. N. Davis, Mr. G. Gordon, Mr. J. Udale, Mr. C. Gibson, and Mr. W. Kipps. There is no sentiment about such men as those. They followed the plan because they found it easy and satisfying. In less than two minutes every one of them could take the lead in indicating the value of the blooms

by points and half points, and it was only when a doubt arose that the quarter and three-quarter point, integers of three or nine, were employed to secure unanimity, and it is certain it could not be arrived at so quickly in any other way. On the evening preceding the Sheffield Show a discussion arose on Chrysanthemum judging, and Mr. B. Simonite declared a maximum of three or four points quite inadequate for representing the small yet important gradations in merit. He thought the points wanted dividing, and his remarks met with general acceptance. It so happened that a page of figures showing the pointing in two columns for each collection in a large class could be produced. He grasped the plan in a moment, and said, "That is the best system I have seen," and with the instinct of a real florist continued, "You cannot get far wrong with that if you take care of the key bloom." That is the key to the position. Fix on the best bloom in a stand, very carefully determine its value, and work from it as a standard throughout. When there are several stands, which necessarily occupy time in "going through," it is well to step back to the key now and then, so as to have it clearly in mind for the prevention of an accident occurring in under or over pointing. I have known this to be necessary, and at least one of my colleagues knows it too. The ideal standard must be clear throughout for the work to be done well, whether the points be divided or not. I shall prefer the latter method until finding a better, then will adopt it with readiness by whomsoever it may be introduced. I have, however, had about enough of judging, and shall most willingly stand aside when the committees of shows may desire to try a change of officials. "Has your judgment ever been questioned?" asked an inquisitive interviewer a short time ago. I was able to reply, "Yes, several times, but it has never been overturned by scrutineers." To this he aptly rejoined, "Oh, then you can retire with credit." Rather a broad hint, I thought; and it "sticks."—J. WRIGHT.

[Mr. J. Udale writes, in reference to this subject, "I have noticed with pleasure Mr. L. Castle's allusion to Mr. Wright's system of 'pointing.' Having tried it on several occasions I can testify to the excellency of the system, and I think nothing could be more perfect, practical, and simple."]

### OIL AND SULPHUR ON HOT-WATER PIPES

IN the *Journal of Horticulture* for October 20th reference is made to the oil and sulphur remedy for mildew, from which we learn that some uncertainty exists as to what kind of oil should be used. As first stated in the "Gardeners' Monthly," and on several occasions since; linseed oil has been invariably recommended. This is mixed with sulphur to the consistency of a rather thick paint, and in this state as much of it is rubbed on the hot-water pipes or flues as to fill the house with a strong odour. In so doing no harm to the most tender foliage need be apprehended, while at the same time every vestige of mildew that may be in the house will speedily disappear.

We have had the most satisfactory evidence of this, and need only mention one or two cases by way of proof. In one instance a neighbour owned a large greenhouse chiefly devoted to Roses that were so subject to mildew that he was on the point of giving up their cultivation, every known remedy having failed to subdue the enemy. In this plight he was advised to try the sulphur and oil mixture. He did so, and had the satisfaction of finding the cause of his trouble entirely removed. Another case is that of a house in which Roses are chiefly grown. As soon as the fires were lighted in it last autumn the mixture was applied, and from that time until a few weeks ago not a sign of either mildew or red spider has been seen. The same practice has been followed this season with the utmost confidence that so long as the fires are kept on these troublesome pests will not be once seen.

I was pleased to notice in the "Gardeners' Monthly" for

October that Mr. Meehan has "by research in chemical botany discovered that oil vapour has long been known to be inimical to the growth of the lower forms of fungi, and that what we recommend is in full accord with the teachings of this branch of science," from which we infer that the vapour of oil is alone sufficient to destroy mildew, and if so the remedy is somewhat simplified, but sulphur added cannot fail to greatly increase its power to destroy either animal or vegetable parasites.—A. VEITCH, *New Haven, Conn., U.S.*

### QUALITY, QUANTITY, DEPRESSION.

FROM an economic point of view the apathy of consumers in respect to quality is about equal to the prejudice of cultivators in clinging to varieties which time has rendered obsolete. Consumers of late years have favoured quantity and appearance, to which no objection can be taken provided it be not at the loss of quality. Cultivators as a class have clung to varieties which are now left behind through the finer and more taking appearance of foreign produce. The latter has the still further advantage of being as cheap or cheaper than home produce. Much of course has been effected by competition and the cheapening of transit to the detriment of the home grower; but the main cause of agri-horticultural depression is the outcome of a period of unparalleled prosperity, which dulled forethought, resulting in a sense of security in the superiority of production, and the consequent decline of effort and industrial energy essential to its maintenance. If prosperity push produce to famine prices it naturally tempts rivalry, and has so acted that foreign produce is forthcoming at prices which the home producer is unable to cope with upon the old lines—*i.e.*, the wages and the rents. The grower must produce as much and keep his hold on the markets in a time of depression as in a time of prosperity, otherwise he must abdicate to the foreigner or colonist. An equally good and cheaper article must be produced, and he must curtail his own expenditure in proportion to the lessened value of the products, and in addition easement must be accorded in the shape of lessened value of labour and of land to enable the grower to grapple with the influx of foreign produce. There must, in fact, be an all-round reduction in the cost of production, the markets being supplied with the best possible products at a price suited to the consumer.

In horticultural matters the depression is quite as pronounced as in agricultural. The farmer cannot provide a supply of food products equal to the demand; it is therefore met by imported in order to the maintenance of our commercial industry, which has passed the crisis safely, and our products maintain their supremacy through superiority and economy of use. The "dawning of a better day" has been effected by cheapening manufacture without any sacrifice of quality. That is as it always has been, and will be to the end. Out of the raw material—the soil—the farmer must, if he mean to keep his place, rival colonial and foreign growers, grow more of a superior article, and it holds equally in respect of horticultural produce, which I propose briefly to pass in review.

The increase of national wealth during the Victorian era produced a demand for the luxuries of life, as horticultural products were, and are still, considered by many, instead of in their truest sense, regarding them as food products; but as time advanced there was a greater diffusion of wealth and of information on the means of production and the uses and value of vegetables and fruit as a dietary, that they came to be looked upon not so much as luxuries as necessities of life. The climax of the prosperity may be set down in 1870. The downward tendency may be set down as commencing in 1875, horticulture in the meanwhile having attained to a state of unparalleled prosperity. It had provoked foreign competition, and I may be excused saying that up to that date the produce of the United Kingdom surpassed in quality any in the markets and brought the best prices. There were of course exceptions which need not be particularised. Since that time—*i.e.*, during the last decade, there has been a powerful rivalry between home and imported produce, and I submit that had the supply of the markets continued in the hands of those making it a commercial transaction they would have held their own against importations. In consequence of the depressed state of agriculture and the non-residence of proprietors many large gardens hitherto used as producing luxuries have been converted into manufactories of produce for sale. There was more or less of that going on from some establishments for at least half a century or longer, but as I set out with the intention of adhering to matters of which I have cognizance we will put it down at forty years. During that time it has been a systematic practice for the gardeners of many establishments, small as well as large, at the request of their employers to dispose of surplus produce. Either the produce was in excess of the demand or selling was resorted to as a means of lessening the cost of maintenance. There need be no question as to what the object was. It



could only be to lessen the cost and render the establishment more or less self-sustaining. It is useless to assert, as is often done, that this is a new thing. It is older, perhaps, than any gardener living, but it was restricted for the most part to the choicer fruits and vegetables, and was carried on for the most part quietly, as a matter of which no one knew anything save the gardener and fruiterer. Still, the proprietor was careful to exact an account, and the fruiterer equally particular in impressing upon intended purchasers the enhanced value the produce had through its being grown by a noted cultivator. I do not say it was a general practice, but I do submit that during the last four decades there has not been any extra demand for a supply of choice fruit or vegetables, but the fruiterer knew exactly where it could be had. The proprietor and grower appreciated alike the exchange and the renown, similar sentiments pervaded the intermediary. In that way much of the choicest produce bringing the best prices was disposed of in fruiterers' shops, which said produce was clandestinely put in the market to the prejudice of the grower for sale. The clandestine grower could put the best fruit only in the market, his purpose being best served by acting so, using himself the middling and inferior; but the grower for sale must dispose of all at a price, and with so much choice. What must he have for the middling and inferior? He could have got out of the dilemma by growing all choice. Unfortunately crops of all kinds are subject to this sortment—viz., best, middling, indifferent; consequently the private grower selling the best only and using the remainder had the command of the market, though the grower for sale of necessity had to dispose of all his produce. At one place I was we sold all the best Pine Apples, the Grapes, and Pears, and I found the Pine Apples and Grapes, also Pears, brought a much higher price than was obtained by a grower of fruit for sale. This is a parallel case to the produce imported, which is uniformly the best the grower can export, and against which the home grower can only act at a sacrifice of the middling and indifferent, which points to a high standard being aimed at, and as so that the samples are very much higher and uniform than formerly.

Having nearly reached the end of the tether what is to be done? The grower for sale must insist that private gardens diverted from their original use—i.e., converted into market gardens, should be placed on an equality. The owner can let his garden or he can cultivate it. That need make no difference, but to make the matter equal all his structural erections used for the purpose of trade must be rated in the same ratio as those of the occupier or owner of similar structures used for commercial purposes. In that way we place all growers for sale upon an equal footing. With that I have no fear of our horticulturists being able to give a good account of themselves in the rivalry with those of other lands.

It may be presumptuous, yet I cannot refrain from suggesting that as our gardens cannot be maintained in order and efficiency there should be a reduction in their size corresponding to the reduction in the capital and labour. As it is there is no satisfaction to the proprietors nor any credit to the cultivators. Gardens do not, any more than farms, pay to lie idle, and the sooner they are put to useful purpose the better it will be for the proprietors, cultivators, and the community.—G. ABBEY.

(To be continued.)

### TENNIS GROUNDS.

I HAVE omitted the word "lawns" often applied to tennis grounds, because I am of opinion that excellent courts may be formed without a lawn. So long as the weather is fine and the ground dry, turf forms a good surface on which to play, but in wet weather, and throughout the winter, as a rule, a turf surface is not by any means agreeable, as it is exceedingly damp for the feet, and often becomes quite a puddle. The weather for days and weeks together in winter is sometimes so wet as to make the grass quite unfit for playing. It may be that some regard tennis as a summer game, but I know many instances where it is also indulged in to a great extent during the winter, and I think it is very desirable that the ground should be formed in such a way as to admit of playing immediately after rain. Where space is plentiful there might be two lawns, one on the grass and another with a dry surface, but where only one lawn can be made I am in favour of the latter.

Some ten or twelve years ago I often saw tennis played extensively in the Midlands, and they had a good plan there of arranging their courts, as the playground consisted of a large level grass quarter, and the courts were marked out on this with white cords placed on the smooth surface of the grass and drawn very tight. These were shifted crossways, longways, or any way that was necessary to keep the grass even on all parts, and I thought this a good plan for the grass, but the best court for wet weather I have

yet seen is one formed here eight years ago. We began making it by digging the entire length and breadth of the court out to a depth of 15 inches. Rough stones were then placed in to a depth of 1 foot, and they were levelled on the surface. The top layer was then applied, and consisted mainly of gravel with a little lime mixed in it. This was made perfectly smooth and very firm, and then allowed to settle. In a month or so it was again dressed on the surface with a rake, and afterwards rolled, and the result was a first-rate court. Many a game has been played on it in the best weather in summer, and it has afforded no end of amusement in the winter, as no matter how much rain falls, the surface is dry an hour afterwards. It becomes a little rough on the surface at times, but a raking and a good rolling makes it as perfect as if it was new again. We put down the lines with silver sand, and we have found this answer so well from the first that we have never tried anything else.—M. M.

### EXHIBITING AND JUDGING BOUQUETS.

"A LEARNER" has contributed a useful article upon this subject, and points out several serious defects in the present system of exhibiting bouquets. From his own statements it is evident he is also an occasional competitor at shows, and it is surprising that one way of stopping the practices which he rightly condemns has not occurred to him. For instance, if he had avoided them himself, and protested against the exhibits of other competitors who were awarded prizes for bouquets that had been finished at the show with Ferns or flowers simply stuck in and not secured, this would have been a more straightforward course than following what he considered a bad custom merely with the hope of securing a prize. It seems to me that the others might all urge the same excuse as himself, and join in a condemnation of a practice that had, however, been found necessary to insure prizes.

That the custom is a bad one there can be no doubt, but it would be easy for the committees of societies, when framing the schedules, and the judges, when officiating, to stop it. A bouquet, in which all the flowers and fronds used are not properly secured cannot be regarded as complete, and however tasteful it may be in design, should not be placed before one that is suitably finished.

As regards the composition of a bouquet, the greatest evil is crowding, and next to this is looseness, though this is more rarely seen than the former. Some appear to think that a bouquet should be perfectly even, either flat or of a semi-globular form, and they are occasionally seen as regular if they had been clipped round; others, again, go to the opposite extreme, and make their bouquets irregular bunches quite devoid of method. Extremes should always be avoided, and it must be borne in mind that it is "the greatest art to conceal art." Then there is great scope for the display of good or bad taste in the choice of colours. "A Learner" correctly observes that too many differently coloured flowers are often employed, but perhaps what he in a general way terms "colours" are sometimes only varying shades. Very beautiful floral designs are produced when several light and dark shades of one colour are employed, as when carefully associated these harmonise in a delightful manner. Contrasts are sometimes desirable when a bold effect is required, but these, like discords in music, should only be introduced very sparingly and with a master hand, or they fail in their object.—AN AMATEUR FLORIST.

Now that so many objections are being raised to the enormous size of bouquets sometimes exhibited, I hope, for the benefit of all parties concerned, that the subject will be thoroughly discussed and brought to some definite issue. To exhibit such monstrosities as have been put up at some of the principal west of England shows during the past season in a class for hand bouquets is beyond all reason. The exhibitors and judges must have quite lost sight of the purpose for which bouquets are intended—viz., to be carried by ladies, very few of whom, I think, would prefer such monsters 2 feet in diameter to those of the ordinary size. If the managers of exhibitions think that such large floral devices add to the attractions of the show, and are pleasing to the public, why not provide two classes for bouquets, one in which the size is limited to a certain diameter, and another in which the prizes will be awarded to the largest and best arranged examples? This would allow the constructors of the huge bouquets in question full scope for the exercise of their talent in that direction, while the good taste and skill displayed in making up those of a more useful size would have a fair chance of being rewarded.—ON-LOOKER.

As an exhibitor of bouquets and table decorations at the principal shows in England, I should like to offer a few remarks, especially in bouquet making and judging. I was pleased to see Mr. Garner take the subject up, and bring forward the rules introduced by Mr. J. Robson, in 1871, which I should like to see enforced at every show, and particularly Rules 1 and 4. As regards size of bouquet, I should like to see a limit stipulated in every schedule; it would give all an equal chance then, and induce more exhibitors to enter. The very reason I went to one show this year, 100 miles from home, was to encourage this sort of thing, as the limit of size in the bouquet class was stated to be 10 inches—without paper and Fern—and the basket 12 inches. The prize was £1, and brought a good competition of about twelve exhibitors, some having bouquets double the size stipulated.

The attention of the Secretary was called to the matter, and he promised to point it out to the Judges. Upon returning after the judging we found one of the large bouquets, 18 inches in diameter, placed first, a 10-inch one second, and a 15-inch one third. On speaking to the Secretary about the mistake we were told that the Judges considered it was a frivolous objection, as the best bouquet had gained the prize. Now, that sort of thing must not be allowed. Let the rules be strictly carried out.

I have through four years of showing strictly kept to the plan my father taught me when, after school hours, he would give me a few flowers to make into a bouquet, and to my delight at the age of fifteen I took a second prize at Weston-super-Mare. The following year I took two first prizes and a second at the Alexandra Palace. I always endeavoured to procure the best flowers, especially those I was sure would keep—namely, double Primula and Roman Hyacinth, in preference to Bouvardias, Ixoras, &c. I have found a good bouquet with Bouvardia in it as fresh as possible upon taken from a box, and in ten minutes afterwards on a hot summer's day they were down flat on the other flowers. The past season has been a good one to test bouquet making. Respecting the colours, I seldom use more than three, great favourites with me being Miss Jolliffe Carnations, Maréchal Niel Rose, and white flowers lightly placed together, every flower showing its proper shape, and wherever possible place it as it grows. Keep the bouquet a good shape, work the light sprays of Ferns in with the flowers and amongst the wires with moss, so as to avoid any addition on the show table. An attraction is to allow suitable flowers to hang on the Fern over the paper. Eucharis candida or Stephanotis with Primula are very pretty. For two seasons I had much success with bouquets made in this style, but I began to lose ground, and then discarded Miss Jolliffe Carnation in favour of Cattleyas and choicer flowers, which kept well and looked handsome. Often this season the bouquets have cost me the value of the second prize, and when beaten it has been by much larger bouquets, worth double the prize money. Why should this be? I consider if the prize is £1 the limit to the bouquet should be 18 inches; of 15s. it should be 15 inches, and so on. For, if gaining first prizes means a loss, how many will continue to show? As "A Florist" says, we shall only see one or two bouquets on a show table instead of a dozen. I have been beaten by bouquets with ten and twelve colours in them, which I think is wrong, but as there is such a diversity of opinion I think that had better be left to the Judge. But I consider that bouquet and table decoration Judges should be appointed with some discretion, as it is not everyone who is qualified to act in this capacity.

Speaking of table decorations, I may say I always make the middle stand rather heavier in appearance than the ends. In the case of three stands, on a dinner table, by using darker flowers the end stands always match and to lightness in this as well as in bouquets I owe much of my success against very elaborate tables and choice flowers. Once this season I was defeated by a very unsatisfactory table for a good prize, but I took the beating without complaint, for I knew I did not deserve it; and it is my advice to all, derived from experience in a short but active showing career, to take such matters quietly, and try again another time. I think that the same Judges never ought to judge the same classes two years in succession, for I have heard it said, "So-and-so is always Judge here; he likes your work." My wish is that there should always be good prizes offered for table decoration and bouquets at all shows, for that is the most attractive part of many. By restricting the sizes of bouquets and encouraging lightness in table decorations, this will be encouraged.—J. R. CHARD.

### STRAWBERRIES PREVIOUS TO FORCING.

OUR Strawberry plants for forcing in the spring are not so good this winter as we have generally had them. We were later than usual in securing the runners. The excessively dry and hot weather was not in favour of their rooting rapidly, and the adverse circumstances generally which they have had to contend against has caused them to be smaller than is generally the case, but their treatment before forcing and at present will not be altered from that of previous years. Beginners with Strawberries in pots are very apt to think that when in pots the plants are not quite so hardy as when in the open ground, and they frequently keep them covered with glass, in frames or in some other place, under protection from the autumn, until they are placed in their forcing quarters in spring. But this is no advantage to the plants, and very often quite the reverse. There is no use trying to keep the large leaves on the plants during the winter with which they were furnished in August and September, as it is not these which produce the fruit, but the crowns of the plants, and these are not easily injured. Indeed crowns of medium size often fruit as well, or better, than large ones, especially if the latter are not well ripened and the former thoroughly matured. Small hardy crowns always winter well and start into growth freely, but they are all benefited by a complete rest, and it is this I advocate for them before forcing begins. As the weather in winter is often very wet, the roots may become too wet if the pots and plants are allowed to stand upright, but if they are laid on their sides, with the plants facing the light, they will be in a good position for passing the winter. No amount of rain will injure them then, and if a covering of straw, fern, or something of this kind is placed over them during the time of frost, and removed afterwards, they will keep capitally. If there are any empty frames, these may be placed in these in a standing position, and the lights should be placed over them when there is much

rain or frost, but do not keep them closed when there is no occasion for it. Another way is to plunge the pots up to the rims in ashes, but I could never discover the advantage of this plan. The important point of all, however, is to keep them cool until forcing begins, as a complete rest is highly beneficial to them, and where they are kept in a semi-growing state all the winter, the crop, in nine cases out of ten, will be unsatisfactory.—A KITCHEN GARDENER.

### STABLE MANURE.

MR. BARDNEY having practised the method of treating stable manure as advocated by us, and now having found that practical experience demonstrates a better and more economical method of dealing with it, he is certainly entitled to be listened to with respect; but after all it very much depends upon the circumstances we are surrounded by, and, as your correspondent says, with what kind of soil we have to deal, whether light or heavy. Having to deal chiefly with soil, if not heavy, yet resting on a cold heavy subsoil, and at the same time very deficient in humus, we do not see at present that we can beneficially alter our practice with regard to the treatment of our stable manure. It is a very different case when we have to deal with old gardens often too rich in humus and decayed vegetable matter; on such the manure we get may be only of little benefit, but with land such as ours, which has been for years only cultivated very shallow for farm crops, even decomposed straw, we are persuaded, is helpful in providing a rooting medium if it does not furnish much in the way of plant food. We do not doubt for a moment the soundness of Mr. Bardney's doctrine with regard to the fixing and non-fixing of the ammonia, provided his theory be correct as to there being little or none to fix; and the question as to whether the manure is best lying on the surface or pointed in has to our mind long been an open one. As we have said before, it is very much a question of circumstances. Were we to follow out Mr. Bardney's advice it would entail a very great deal more labour than we now bestow upon the manure (this being controlled by local circumstances), and we are not yet convinced that we should be the gainers, since ammonia can be purchased close to our gardens and applied so cheaply. We quite agree that it would be much sounder economy to dry the best of the straw and use it again, and often have regretted not being able to do so instead of going to the trouble we have to do to bring it into a decomposed state. At the same time we are convinced that if we are not following the most scientific mode of utilising our manure, that we are at least doing the best under the circumstances. That the manure from the cow market or town stables, also provided the latter has not heated, is much better than our decomposed straw and horse droppings (although we get much of the urine with the straw) we have not a doubt.

We remember the late "Single-handed" in reference to this matter said, "I have seen no plan so feasible as sprinkling the manure heap with kainit, for a triple reason. It is cheap, it saves the ammonia, it furnishes potash and other salts."—WM. JENKINS.

### THE GARDENERS' ORPHAN FUND.

A MEETING of the Executive Committee of the above fund, which was well attended, took place at the Caledonian Hotel, Adelphi Terrace, W.C., on the 2nd inst., the Chairman of the Committee, Mr. George Deal, presiding. The minutes of the last meeting having been read, the Secretary, Mr. A. F. Barron, reported that since the last meeting he had received the names of sixty-six new subscribers, who had contributed in donations the sum of £15 9s., and as annual subscriptions £17 10s., making a total of £32 19s.; also that during the interval nine of the recently appointed local secretaries to the fund had sent in the sum of £29 10s. 6d. in donations and subscriptions. Mr. Barron further reported that since the establishment of the fund the sum of just over £941 had been promised as donations, of which amount £614 15s. had been paid; that as annual subscriptions £211 10s. had been promised, of which £128 16s. had been received. A copy of the declaration of trust was produced, under which the Trustees are proceeding to invest the sum of £500 in 3 per cent. consols, in accordance with a recent vote of the Committee. The Chairman then submitted a financial statement, premising it by saying that under the rules the Committee were required to fund all donations, and having regard to the support given to the Committee all over the country, he thought they might safely assume that by the end of the first financial year on the 30th of June next they would be in a position to invest in the funds a further sum of £500.

He then set forth figures showing what might be reasonably regarded as the amount available in July next for boarding out orphan children under their rules. After deducting all necessary expenses, and he put it to the Committee whether they should take early action for the purpose of placing some children upon the fund or defer it for a time. No election could take place until the annual meeting in July next. After some discussion the following resolution was unanimously carried:—"That in the opinion of the Executive Committee the success which has attended the establishment of the Gardeners' Orphan Fund is sufficiently assured to justify them in inviting subscribers to the fund to submit the names of orphan children as candidates, and that at the annual meeting in July next at least six orphan children shall be elected on the fund." A Sub-Committee was appointed, consisting of Messrs. G. Deal, W. Roupell, C. H. Sharman, B. Wynne, and A. F. Barron (Secretary), to make the necessary arrangements for the ensuing election, and submit the same to the Executive Committee.

Letters were read from Miss Mason, an inspector of boarded-out children under the Local Government Board; and from Miss Akers, the Secretary of an organisation which under the regulations of the Local Government Board takes the oversight of the boarded-out children, both of whom promised assistance in the matter. A letter was read from the Rev. H. H. D'Ombraïn, offering the use of the Horticultural Club as a meeting place for the Committee. A hearty vote of thanks was given to Mr. D'Ombraïn for his offer. Mr. Barron announced that some members of the Seed and Nursery Trades had taken between them 40,000 subscription forms for placing in their catalogues, a cordial vote of thanks to Mr. Deal closed the proceedings.

Further donations and subscriptions will be thankfully received by Mr. A. F. Barron, Royal Horticultural Society's Gardens, Chiswick, London.

### WADDON HOUSE, CROYDON.

WITHIN a few minutes' walk of Waddon station, near West Croydon, Philip Crowley, Esq., has a pleasant suburban residence, and a garden in which he takes considerable interest. For several seasons Chrysanthemums have constituted an important feature there during November, and this year a very fine display was provided, to see which several members of the Royal Horticultural Society's Committees with gardeners in the district were recently invited. That the gardener in charge (Mr. W. King) has been more than ordinarily successful can be judged from the fact that he succeeded in defeating Mr. C. Gibson at the Croydon Show with cut blooms. This was an honour of no small importance, as, though the residences of Morden Park have been heavily taxed this season, the blooms were good, and Mr. King therefore achieved a success as a young Chrysanthemum exhibitor of which he might well be proud. Between 600 and 700 Chrysanthemums are grown, and the majority of these were arranged in two lean-to houses, one being chiefly devoted to incurved and the other to Japanese. A larger number of the latter are grown, as they are especially valued for their bright and varied colours, and at the time of the visit already mentioned the plants formed a bank of rich and beautiful flowers, the products of well-grown plants, as evidenced by the short firm wood and large, leathery, dark green leaves. The collection is a large one as regards number of varieties, including most of the best in cultivation, and to enumerate those well represented would take up too much space. The following were, however, unusually good in size of blooms and excellence of form—*i.e.*, Madame C. Andiguier, Comte de Germiny, Grandiflorum, Val d'Andorre, Elaine, Criterion, Belle Paule, Meg Merrilies, Agréments de la Nature, Triomphe de la Rue des Châlets, Thunberg, Fair Maid of Guernsey, and Album Fimbriatum. Amongst the incurved the Queen family constitute the leading varieties, Lord Alecster being remarkable for its deep blooms and broad clear florets, Refulgence also, and John Salter with Lord Wolseley have been capital. Of the reflexed Cullingfordi is a favourite and is thoroughly well grown, its rich substantial blooms showing up admirably amongst the other lighter varieties.

But Chrysanthemums are considered only as a temporary or seasonal attraction, the numerous convenient houses being devoted to Orchids, Ferns, Palms, and miscellaneous plants that throughout the establishment are distinguished by their fine condition, and many are specimens up to a good exhibition standard. They have gained honours at more than one show in brisk competition, and they are growing still more formidable to rival exhibitors. Amongst the Ferns are splendid plants of *Davallia Mooreana*, *Adiantum farleyense* and others, with a wonderful example of *Microlepia hirta-cristata*, which from tip to tip of opposite fronds measures fully 12 feet, and it is in the most vigorous health. Two other Ferns that are thoroughly well grown are *Trichomanes radicans*, the Killarney Fern, and the delicate *Todea pellucida*. The *Trichomanes* is 4 feet in diameter, and crowded with its translucent fronds, the *Todea* being about a foot less in size, but similarly healthy. Of other stove foliage plants *Dracænas* and *Crotons* receive much attention, the former comprising *recurva*, *Lindeni*, *Baptisti*, and *majestica* of fine proportions, and clothed with leaves to the base of the stem. A pair of *D. Lindeni* in particular are very handsome, 5 feet high, with broad well developed leaves; *Asparagus plumosus*, *Anthuriums*, and several Palms are noticeable in the collection.

The flowering plants include Heaths, Azaleas, together with the ordinary conservatory plants, but there are also some of unusual interest. For instance, a plant of *Impatiens Hawkeri*, a grand bush over 5 feet in diameter, is very remarkable. This is only two years old, and yet it has formed a fine compact specimen of that size, and has borne numbers of its large deep red flowers. It is much superior to the now well-known *I. Sultani*, as it makes a plant of better habit, retaining its lower leaves longer than the other. The graceful yellow drooping *Ureolina pendula* is grown in pots, and produces its flowers freely, while on the roofs of the various houses the most noteworthy plants are the elegant *Petrea volubilis*, the large flowered *Aristolochia ornithocephala*, and the neat *A. elegans*, the imposing *Hoya imperialis*, which has had eight large clusters of flowers this year, the free little *Ficus repens* on several walls, a very large *Lapageria rosea* in the conservatory, which has produced several thousands of flowers, and a fine *Passiflora quadrangularis* in the same house.

To give an adequate note about the Orchids at Waddon House it will be necessary to pay another visit later on, but the *Cœlogynes* cannot be passed without a word, as they are quite extraordinary, and afford an

eloquent defence of the system of employing small pots for Orchids. The plants are good varieties of *C. cristata*, and are in 32 and small 24 sized pots, the pseudo-bulbs overspreading the sides and nearly reaching the stage upon which they are placed. One in the former size has thirty spikes showing, the others are producing forty-eight and fifty spikes each, while one large specimen, over 3 feet across, will probably have 100 spikes. The healthy condition of the plants, their stout pseudo-bulbs and firm leaves, prove that they receive liberal treatment, weak liquid manure being employed with discretion, as it also is for other Orchids of strong constitution; but advantageous as this undoubtedly is when judiciously applied, it is dangerous in the hands of inexperienced persons. *Dendrobiums*, *Cypripediums*, *Cattleyas*, and cool house Orchids are well represented, but the most notable within the past few weeks has been *Liparis pendula*, which, though rarely seen in gardens, is scarcely less attractive either in grace or fragrance than the favourite *Dendrochilums*. Three plants in small pots have from twelve to fourteen long pendulous spikes of pale yellowish minute flowers closely placed, and the fragrance is of a peculiarly agreeable aromatic character. For vases they are very useful, and last nearly a fortnight when cut and placed in water.—C.

### CHRYSANTHEMUMS IN AMERICA.

WHILE we have been busily occupied with the Chrysanthemum shows in this country our American horticultural cousins have also been similarly engaged, the popularity of this flower and the number of shows increasing rapidly within the past few years. The "American Florist" gives a series of reports in the November issue just to hand, and several of these are written by a lady in such an amusingly critical strain that a few passages may be reproduced.

NEW YORK.—The exhibition in this city seems to have been very satisfactory, and is thus noticed by the correspondent in question. "The New York Horticultural Society has scored a big success. After a good deal of hard work and a certain amount of anxiety they have produced a Show recalling the palmy days of Madison Square Garden, when they used to turn that desolate caravansary into a tropic jungle. The centre point of the Show must, of course, be the Chrysanthemums, but the interest was not confined to this class of plants. There were some good Orchids and some fine decorative plants. The Judges had rather a difficult job to decide on the merits of the best flower in the Exhibition, but they finally settled on *Troubadour*, a large fluffy pink Japanese. There were others that excelled it in size, but not in general excellence. Peter Henderson was winner of the prize for new varieties introduced since 1885, and also for largest and best display of named kinds. Some of his new varieties were of very great merit, notably a rich ox-blood red, John Welsh.

"The baskets and vases filled with Chrysanthemums and Ferns cannot be very highly praised, and the bouquets of the same flowers were very poor; they were like nothing on this earth so much as Derbyshire birch-besoms, being built on the same model.

"The prize standards were shown by Geo. McClure. Among the many unique varieties shown by this exhibitor was *Leopard*, mauve, strangely spotted with pure white. Another mauve seedling of note is *Volunteer*. Mr. John Pettit is a terra cotta seedling of Mr. Spaulding's, chiefly noticeable for the way the petals were whorled; the heart of the flower being turned in an opposite direction from the outer ring. *Dragon's Head* was a pale pink with oddly notched petals; *Robt. Bottomly* is a big white, very noticeable."

BOSTON.—This show was held by the Massachusetts Horticultural Society, and was well patronised by exhibitors and visitors. "The Society has much reason to be proud of its Show this year, for in almost every particular it was the best exhibition of the kind it has ever given. The quality of the plants was far beyond anything ever seen here, and it would be difficult, if not impossible, to excel the specimen cut flowers shown, either in size, variety, or form. The premiums offered this year were larger than ever before, and this fact encouraged the growers to unusual efforts. With the exception of the usual fringe of fruit and vegetables about the sides, and a small group of Orchids and cut Roses on the stage, the plants in competition for the special prize for twenty named plants in 8-inch pots were sufficient to fill the lower hall. The premiums in this class were 100, 75, and 50 dollars."

A first prize equivalent to £20 is rarely offered for Chrysanthemum plants in this country, in fact this part of exhibitions is often somewhat neglected in framing schedules. The result is that there is a perceptible decline in specimen culture, and it is only a few, like Mr. Beckett of Elstree, who have the opportunity of devoting the necessary time and care to their production.

NEW JERSEY.—Referring to this Show the lady correspondent observes:—

"This was purely a Chrysanthemum Show. There were some few cut Roses and foliage plants, but the Orchid family was represented by one sad and lonesome *Zygopetalum* only. Still, we can hardly complain on this score; the Chrysanthemums were the object of the Show, and undoubtedly the strong attraction. All the old favourites were there, but naturally most interest was felt in the direction of the novelties. The Spaulding prizes, six in number, awarded for new seedlings, have called out a lot of promising infants. These prizes are awarded by Mr. Spaulding with the understanding that all stock of prizewinners is to become his property; the growers are to have the privilege of naming their plants, and in the spring of 1888 are to be furnished with one



plant of each variety entered. The novelties all run largely to oddity rather than beauty; connoisseurs have become weary of ordinary types, and lavish their admiration on flowers that impress outsiders chiefly as horticultural jokes. It requires a liberal education to appreciate them on first introduction. The Pitcher prizes for the best single specimen and best specimen standard were taken by George McClure; the same grower took the May prize for the best collection. Mr. McClure also took prize for the best display of dwarf Chrysanthemums to be grown in 6-inch pots. This was one of the most interesting features of the Show. The flowers were, almost without exception, particularly fine; the plants were well grown and tastefully grouped. One of the handsomest flowers in this group was Cullingfordi.

"Thorpe Junior still stands at the head of the list among yellow Anemone-flowered varieties, while John Thorpe finds a worthy namesake in the deep crimson flower that bears his name. For size as well as beauty Mrs. Frank Thompson requires special note. It is a soft silvery pink with a slight tinge of mauve, and has the usual straggling Japanese form, slightly incurved. It is particularly large and striking. Another superb new variety at this Show was G. F. Moseman; one needs a whole dictionary of adjectives to do it justice. It is an irregularly incurved Japanese; the petals are buff without, and bright terra cotta within. It is very large and robust.

"Two charming new whites are Mrs. Langtry and Mrs. T. H. Spaulding. Both are picturesquely irregular in form; the first-named is especially noticeable for the width of its petals; the flower rather resembles a fluffy bunch of white ribbon."

Floral decorations are usually important features in American shows, and occasionally we have good examples at home; but at New Jersey this department induced the following observations:—"The poorest feature of the Show—we are treading on delicate ground now—was the display of designs. Most of them were criminally ugly; they really ought to have been suppressed, out of regard for the sacred name of art. The first prize original design really gave one a pain in the eye. It was a sort of Japanese cottage—at least we will call it a cottage—of autumn leaves and flowers. It stood in a thicket of plants fairly arranged. A papier mache Jap in a Chrysanthemum toga peeped out of the door; he was not so very offensive, because he was partially concealed. In front another Japanese sat, or rather sprawled, in a rustic chair; he held a cigar in his hand, and judging from his appearance he had indulged, not wisely but too well, in the cup that cheers and also inebriates. His clothes were also built of Chrysanthemums. This design was altogether indescribably affecting."

CHICAGO.—At this town there seems to have been little of special consequence, but a note respecting the first-prize floral design is worth reproduction. This was "a two-sided panel, one side of fronds of *Adiantum graecillimum*, with a basket of choice Roses embossed upon its side surmounted with two handsome bunches of *Lapagerias alba* and *rosea*; the reverse side bore two hearts partially joined, one of crimson Roses the other of Violets, skewered together with a Chrysanthemum arrow. The side first described was really handsome, but the last was altogether too suggestive of the 10-cent '18-carat rolled gold engagement rings' of the agricultural paper advertisements, and gave a shiver to sensitive people."

CHRYSANTHEMUM DECORATIONS.—At this time of year Chrysanthemums are largely employed in floral decorations, and from the same source as the preceding is obtained the following note of two very tasteful productions by the American florists:—"The season of dinners was ushered in with one given at Delmonico's to Count de Brazza the evening before he sailed with his bride for Europe. The cloth was cream-coloured satin. Through the middle of the board was an oval of plate glass to represent the ocean. This was supported on a band 9 inches wide of Thorpe, Jun., Chrysanthemums. At one end, placed in a crescent, was 'Au revoir,' in large letters of Neapolitan Violets, and at the other end was 'De Brazza,' in the same flower. Each letter was the same on both sides, and a favour to be presented to a guest after the feast. The letters 'Au revoir' were attached by sashes, the colours red, white, and blue alternating. The Italian colours alternated on the letter favours 'De Brazza,' and were red, white, and green. The sashes were drawn to the centre of the plate glass ocean, and there a French knot was made—brilliant rosette of loops. Among these loops large boutonnières of Forget-me-nots were laid. It will be seen that the prevailing style has reversed the placing of ladies' favours as a centre and brought the men's buttonhole ornaments there. Boutonnières are made of immense size for dinners. A single large Chrysanthemum, such as Mrs. Wheeler, is worn. Fred. Gordon made a dinner arrangement for an entertainment given Henry Irving on the 5th inst. A star 5 feet across was composed of all the golden and bronze shades of Chrysanthemums. This was festooned, fringed, and finished with admirable taste. Loops of old gold ribbon formed a satin mat that showed only between the points of the stars. The boutonnières were formed of Roman Hyacinths, there being from six to eight spikes in each. The room was profusely trimmed with autumn leaves, Chrysanthemums and Roses."

#### NOTES FROM HINDLIP.

HINDLIP, or Hendlip, as it was termed in olden times, has, in common with many other places in Worcestershire, an interesting history. It was here that some of the conspirators connected with the Gunpowder Plot hid for several days after its abrupt termination, and it was in the house occupied by Mr. A. Barker, the head gardener at Hindlip, that the letter from Mrs. Abington to her brother, Lord Montague, exposing

the plot, was supposed to have been written. Unfortunately the old mansion built by Mr. Abington, and abounding in wonderfully constructed secret chambers and passages, has been destroyed, and a much less interesting, though remarkably well built structure, has taken its place. This, however, it should be added, was not the work of the late Lord Hindlip, who, I believe, much regretted such an uncalled-for act of vandalism. The church close to the pleasure grounds and the vicarage, the house just alluded to as being occupied by the gardener, yet remains to interest lovers of historic research, and there are also a number of grand old Elm trees that must have been standing in those times. Some of these giants have the largest stems I have ever seen. A new feature is being added to the place in the shape of a lake of water, and this will enhance the beauty of an already charming landscape, including the famous Malvern hills in the distance. I shall make no attempt to describe all that may be seen, including the number and position of the houses, at this well kept place, but instead of this propose to take the various departments of the gardens in detail, commencing with the

PLANT HOUSES.—There is no conservatory, but numbers of plants are employed in house decoration, and some of the houses near the kitchen garden are maintained in as attractive state as possible. Chrysanthemums are extensively and well grown, including many for producing large blooms. In former years Mr. Barker has exhibited most successfully at Birmingham and elsewhere, and had he decided to compete this year would have been a formidable opponent. All the best sorts are grown. They are all principally grown in 9-inch pots, and are not stopped. When the buds are set a top-dressing of loam, charcoal, and a sprinkling of Clay's manure is given. Any kind of liquid manure calculated to clog the surface soil is avoided. When the plants need assisting in order to keep the foliage healthy and strong, good clear liquid manure is obtainable by soaking a bag of pigeons' manure in a tub of soft water, this lasting a long time. Later on sulphate of ammonia is used, first at the rate of one-quarter ounce, and later on double that quantity to the gallon of water. Many do more harm than good with this manure, but not if they adopted Mr. Barker's plan of weighing out the quantities requisite for a large can of water, screwing these up singly in paper ready for use as required. The Chrysanthemums are flowered principally in a light span-roofed house erected for fruit trees in pots. A good variety of flowering plants are grown for the purpose of affording cut blooms. Cyclamens are flowering freely, and there are some fine double white Primulas. The latter are annually propagated, that is to say, every spring the old stems are mossed over, this causing them to strike root freely, and admits of their being safely cut to pieces and repotted. They are at first kept in handlights set in a fairly warm house, and are subsequently shifted into 6-inch pots, and grown in frames with the seedling Chinese Primulas. Cinerarias are also plentiful and the plants strong.

*Nerine Fothergilli* major is better grown than is often the case, plenty of fine flower spikes being annually obtained. Soon after they have ceased flowering, or early in October, they are repotted, being then kept growing in gentle heat, a thorough drying off or resting being given during the summer. Under starvation treatment they make poor progress, but at Hindlip the bulbs are disposed thinly in 7-inch pots, these more resembling *Amaryllises* than the average *Nerines*. *Amaryllises* are also extensively grown, the bulk of the stock being raised from seed. This is sown in gentle heat early in the year. The seedlings are first pried out in pans, then potted off and kept steadily growing in gentle heat throughout the autumn and winter. They are given another shift in the spring, and are kept moving to the autumn, being then dried off and rested for the first time. The strongest of the bulbs flower in the following spring, and the seed being obtained from a reliable source the majority of the flowers are superior to the common old forms. As seedlings are reared each spring it does not take long, and costs but little to secure a large stock of bulbs. Quite large supplies of *Rochea falcata* and *Crassula braetata* are grown and flowered on a dry shelf in a cool house, these two useful and old-fashioned succulents being seldom seen in such good condition. Long red *Capsicums*, well fruited, prove very useful for house decoration during the winter, and the same may be said of a well fruited *Solanum Capsicastrum*, the latter and also *Bouvardias*, which filled two large pits, being grown in the open ground during the summer and potted before frosts were experienced. Semi-double Zonal *Pelargoniums* are extensively grown for affording cut flowers during the winter, such sorts as *Guillon Mangilli*, *F. V. Raspbail*, *La Cygne*, *Candidissimum plenum*, *Madame Thibaut*, *Mrs. A. Lattey*, *Louis Buchner*, and *Madame Dolby* being amenable to gentle forcing. Perpetual flowering Carnations are also well grown.

The *Eucharis amazonica* deserve a separate paragraph. At Hindlip mealy bug is absent, but in order to be thoroughly rid of it the stock of *Eucharises* had to be destroyed. Those to replace them and received from a friendly source proved to be equally as bad as those destroyed, and Mr. Barker decided upon applying a rather drastic remedy. The bulbs were shaken out of their soil, and after having all the leaves cut closely off were roughly and thoroughly cleaned. They were then placed in boxes of sandy soil and set on a hotbed. The whole of them eventually started afresh, and were then potted, about four bulbs going in a 6-inch pot. Plunged in a brisk bottom heat they soon filled these pots with roots, this necessitating a shift into 9-inch and in some cases rather larger pots. Being duly returned into the hotbed in a small forcing house and well attended to, especially as regards shading from bright sunshine, the progress was still most satisfactory. When I saw them in November a great proportion of them were flowering grandly,

the flowers being unusually large and handsome. Altogether this experiment was a most decided success.

Crotons are principally grown for table decoration, a shelf in Pine stove just suiting them. Croton *Heathi elegans*, a variety very popular in the neighbourhood of Worcester, is one of the best for table work, and *C. interruptus aureus*, *Johannis*, and *Countess* are also good. *Aralia Chabrieri* is much liked for table decoration, and is an easily grown stove plant, while the better known and most serviceable *Pandanus Veitchi* is grown in quantity. The bulk of the plants in the fernery are planted out, being ornamental and less trouble thus treated. A great variety of *Adiantums* principally are in small pots, and with these is a fine supply of *Asparagus plumosus*. The latter are freely divided each spring, small plants being the most ornamental. For affording cut sprays a few are planted out, and in time will prove of great service. The hot-water pipes are partially enclosed in boxes, these being nearly filled with coarse rubble and faced with fine gravel, makes a capital bed for pot plants. I must not omit mentioning a fine plant of *Lapageria alba* that was still flowering in large clusters on the roof of a span-roofed greenhouse. It is planted out in a narrow raised brick pit, this being very freely drained, and filled with a peaty compost to which an abundance of charcoal was added. The use of the latter and the perfect drainage admits of abundance of water being given without souring the soil.

**FRUIT CULTURE UNDER GLASS.**—It is in this department that Mr. Barker's long experience under Mr. Coleman at Eastnor Castle is plainly manifest, as taken altogether there are few places where choice fruit generally is so well grown as at Hindlip. Two houses are devoted to Pine Apples, there being several good Smooth Cayennes ripe or ripening at the time of my visit, and a fine lot of plants for fruiting next season. All are given plenty of room, this being one good factor in the production of such sturdy well rooted plants. In each back corner of the pit in the fruiting house, a small space is bricked off for a plant of *Musa Cavendishi*, and these being very liberally treated, when about twelve months produce immense clusters of fine "fingers," which are altogether superior to the ordinary imported Bananas. After the fruit clusters show themselves great quantities of strong liquid manure is given the plants, and this helps to develop clusters 70 lbs. and upwards in weight. The Banana is a welcome addition to the list of autumn fruits, and I have frequently expressed surprise that so few of the noble plants producing them are grown. I cannot say much about the early vineries, beyond remarking that the wood appears most promising for a good crop next season, but in the late houses very serviceable crops of well ripened Lady Downe's, Alicante, Mrs. Pince, Muscat of Alexandria, Gros Colman, and Gros Maroe are hanging. Both of the latter are better finished and of better quality than I have found them elsewhere this season. Both Foster's Seedling and Lady Downe's stock appears to well suit them. Oranges and Camellias thrive admirably on the back walls of the vineries, the roots being confined in narrow borders. The former were heavily fruited, while the Camellias, some of which are 14 feet high, were crowded with plump buds.

Three or four large lean-to houses with high back walls are devoted to Peach and Nectarine culture, both the walls and semi-circular trellising being furnished with grand trees. The whole of the fruit being consumed by the family large gluts are undesirable, and for this reason Mr. Barker prefers to plant rather thickly, especially against the back wall, and in greater variety than is often favoured, in order to secure a long succession. Cordons, or trees with one main stem, are principally grown against the walls. These are planted about 6 feet apart, and trained obliquely, the fruiting wood being laid in right and left each season, and the old bearing wood cut out at each winter pruning. In this simple manner capital bearing wood is secured, and in addition to this system of training admitting of a good variety being grown on a comparatively limited wall space, it may safely be said to be the quickest way of furnishing the walls. Mr. Taylor when at Longleat adopted a somewhat similar method of furnishing an outside wall, though he did not so closely limit the spread of fruiting wood. Mr. Barker's selection of varieties for an early house consists of Princess Louise, the best of the early Peaches, and ripening with him about the first week in May, requiring, however, to be eaten quickly; Hale's Early, this being about ten days later, and is handsome and good; Condor, which ripens about the middle of May, is of good habit, and the fruit of fair size and otherwise good. Then follows the good old Royal George, and after this the handsome and good Dymond. Lord Napier, the earliest Nectarine and very fine; Stanwick Elruge closely succeeds it, and this is described as grandly coloured and richly flavoured; Albert, Pine Apple, and the good keeping Victoria are also considered valuable varieties of Nectarines for forcing or successional houses. In the second early house *Crimson Galande* always does well and is very handsome; Crawford's Early is both early, handsome and good; Stirling Castle, Bellegarde, Alexandra Noblesse—a superior form of the old Noblesse—and Barrington, as well as several of the above mentioned Nectarines are grown. Some of the Peaches just named find a place in the fine late house, and also Princess of Wales, another good late sort; Sea Eagle, handsome late and good, and Lord Palmerston, extra large, and at Hindlip of good quality. Humboldt Nectarine is also highly spoken of, and should be in every collection.

Two light span-roofed houses are in the spring and summer filled with fruit trees in pots and Figs, the former being now set outside, and their pots and tubs protected with litter. They are fine trees, and I can readily believe perfect heavy crops of good fruit. The favourite Figs are Brown Turkey, Negro Largo, White Marsilles, and Black Bourja-

sotte, the last named being of medium size, quite black, and of first-class flavour. All having their roots confined either in narrow raised pits or large pots form very sturdy fruitful growth, and are much more profitable than when planted out in a large border. Such excellent Plums as Green Gage, Jefferson's, Kirke's, and Coe's Golden Drop are grown in pots, and capital crops are taken from Apricots Royal, St. Ambrose, and Moor Park. A few Nectarines and Peaches are fruited in tubs, and these having a clear stem and a head trained over a flat trellis are available for replacing any of the permanent trees on roof of Peach houses. La Grosse Sucrée is the favourite Strawberry for fruiting in pots, this being found the best for forcing. Pauline and King of the Earlies will be tried this season. Tomatoes and Cucumbers are in demand all the year round. Several sorts of the former are grown, including Perfection and Carter's Green Gage, while Pettigrew's Cardiff Castle Cucumber is solely relied upon for the winter supplies, and the plants being of good size before they are fruited they do not break down prematurely.

**HARDY FRUIT AND KITCHEN GARDEN.**—There is a very good number of fruit trees of all kinds in the gardens at Hindlip, Mr. Barker taking a very great interest in this department. Of Pears there are numerous pyramids, horizontally trained, and cordon trees, and much of the fruit produced is of an unusually clean and bright character. Some of the best are Williams' Bon Chrétien, Beurré d'Amanlis, Fondante d'Automne, Beurré Superfin, Louise Bonne of Jersey, Beurré Hardy, Doyenné du Comice, Pitmaston Duchess, Marie Louise, Passe Colmar, Thompson's, Glou Morceau, Knight's Monarch, Winter Nelis, Josephine de Malines, Beurré Rance, Easter Beurré, and Bergamotte Esperen. Many of the horizontally trained wall trees are grand specimens, notably those that have been regrafted with superior sorts. This was accomplished by cutting back all the side branches to near the main stem and inserting the grafts in these, the character of the trees being thus quickly changed for the better. Choice Apples, Plums, and Apricots are also grown on the walls, the cordon system of training the latter being found the best owing to the trees not lasting long at Hindlip. There is a fine lot of pyramid Apple trees all just arrived at a good bearing state. The kitchen garden, and indeed the place generally, is very well managed, and I must not omit mentioning the capital lot of herbaceous plants grown near the kitchen garden. Mr. Barker has been in delicate health for some time, but his many friends will be glad to hear he is now much better, and I sincerely trust will soon be heard of again as a successful exhibitor.—W. I.

#### MEALY BUG ON VINES.

WITH the exception of the phylloxera, which entails the total destruction of Vines, mealy bug is unquestionably the most difficult insect to eradicate. It has been said that to do so is an "impossibility," but experience has proved that such assertions are not well founded, for it can, and has been, cleared out of vineries, not by half measures, but by strict attention and unflinching perseverance for a few seasons. When houses have become badly infested its eradication is not the work of a solitary season, but will entail considerable labour for two, three, or more seasons.

To clean the houses and Vines thoroughly during the winter, and then conclude that all has been done that is practicable, will not achieve success, for upon examination it will be found that the pest is as numerous upon the Vines as was the case before the previous cleaning took place. This will be the condition of any vinery where the attempt to stamp out mealy bug is confined to cleaning and dressing during the resting period of the Vines. Year after year the periodical winter scraping and cleaning is necessary without the slightest appearance of reduction of numbers. If bug exists in a vinery it is certain to get into the bunches, and then the Grapes are almost useless. Whatever may be done to remove the pest the appearance of the Grapes is sacrificed.

In any attempt to clear vineries of this destructive pest gardeners require the co-operation of their assistants. My experience leads me to believe that where gardeners and amateurs are determined to stamp out this insect, they are far more certain of achieving success than many gardeners who, from a constant variety of other duties, compel them to entrust the work solely to their subordinates. Under gardeners may think that I am casting a reflection upon them. I have, however, no wish to do so, but I hope that my remarks may stir them to greater energy, care, and attention in such important matters, so that confidence can be placed in them. I was recently asked by one who had profited by some articles of mine to write again about young gardeners. The one who requests me to do so was without question the best "bug hunter" I ever had. I have had many young men engaged at this work, and the majority of them have been particularly careless, as if they had no wish or desire to exterminate this pest. It is a tiresome operation, and almost enough to weary the most trustworthy and attentive. If, however, our assistants would work with determination, they would the sooner be freed from such disagreeable work.

I must, however, enter into details how the extermination of this insect is to be accomplished, and in order to do so effectually, a start must be made from the time the Vines are pruned. After pruning has been completed, every particle of the old bark should be removed from the Vines, as well as the dead portions of old spurs. The woolly matter about the eyes should be carefully removed, and every portion of the outer bark, from the new as well as the old wood. The removal of the bark from Vines should be absolute, but it becomes a necessity if mealy bug exists upon them. Before scraping the Vines spread canvas sheets

under them, so that every piece of bark can be carried out of the structure and burned. This being done, the wood, glass, and wirework of the house must be washed thoroughly with a strong solution of soft-soap and water, say at the rate of 2 ozs. to each gallon of hot water. This may be syringed off with water as near the boiling point as possible, as hot, however, as can be done without injury to the hands. After this paint the woodwork and wires with pure petroleum. If the house can be painted afterwards with good white lead and oil all the better, but if the wood is clean this is not of very much importance if the previous painting has been thoroughly done. The walls, if limewashed, may be scraped, and every portion of stone or brickwork in the house may be painted with petroleum, the pipes as well, or the former with muriatic acid (hydrochloric acid). This I prefer for the walls and stonework, but it must be diluted with water; if it hisses freely after it is applied it will do. The walls afterwards should be limewashed with the material as hot as possible. If the back walls have been painted with lead paint, then subject them to the same process as the woodwork of the house. The floors and curbs, if composed of flags, may be cleaned with chloride of lime. The former acid will clean them, but it is more expensive than chloride of lime, which will answer the same purpose.

The Vines must be washed, but a strong solution of any insecticide is not advisable; they cannot bear it without injury when the whole of the outer bark has been removed. Petroleum may be advised, and has been on many occasions, for dressing the Vines, as well as other strong solutions. This I consider is a mistake, for the Vines cannot bear strong insecticides after the whole of the outer bark has been removed. Petroleum is too searching and penetrates the wood too far. It also injures the eyes to some extent. I am not alluding to the use of the oil in a pure state. If dressed or liberally syringed with petroleum at the rate of one ounce to the gallon after they have been scraped it will prove too strong for the Vines. After dressings of this description the Vines break, irregularly and very weakly. I advise petroleum to be dispensed with, and the Vines washed with a solution of soft-soap, 2 ozs. to each gallon of hot water. This we have found to do no injury. Even supposing it does not kill any bug in a small state that may be left upon the Vines they can be readily destroyed by another process that will be described. The surface of the border should be removed and all small particles brushed up, placing fresh soil on the surface.

When these directions have been carried out, all has been done that is possible until heat and moisture are applied to start the Vines into growth. After they have been started for a fortnight the work that falls to under gardeners begins, and much depends upon how they perform their duty. In two or three weeks mealy bug begins to come from its hiding places, and the Vines should be examined twice weekly, until they are pruned the following autumn. More can be done by persistently looking over the Vines in their early stages of growth than can be accomplished at any other portion of the season, and they may be so reduced in numbers that the following season will result in their extermination.

When it is certain that some have escaped observation the enemy must be hunted down even after the fruit has been cut. The syringe, which can then be used freely, will assist wonderfully in keeping them in check, but this will not prove sufficient, for if any exist they are certain to establish themselves in safe positions. In early and second early houses keep the sub-laterals well in check, and with this object in view every precaution must be taken to preserve the main foliage of the Vines. The work of finding the bug is materially increased when the laterals are allowed to extend. In August and September all the sub-laterals can be removed and the main leaves only left. This gives every chance for examination, and in this stage when the foliage is hard and leathery the whole house, Vines as well, must be thoroughly syringed with petroleum and water. One ounce of the oil should be used to each gallon of water, the oil being well mixed with the water by the method that has been so many times described. The Vines should be thoroughly drenched, which will result in the destruction of all small insects that may have established themselves on the leaves. This may be repeated in a week or ten days; in fact, every two or three weeks until the foliage falls. In each case the house must be shaded until the whole of the oil has been evaporated to prevent the foliage turning yellow. Those with houses full of fruit at the present time in which bug exists may with safety follow this method at once, and it will be found that their numbers will greatly be reduced before pruning time arrives. It may here be mentioned that after the laterals have turned brown and commence ripening the spot where a bug is killed may be touched with a small gum brush that has been dipped in pure petroleum. This will insure the destruction of any insects that may be left. It must be done carefully by shaking out of the bush all the oil except that which naturally adheres to the bristles. This is a safeguard against the application of too much oil, which would certainly penetrate and injure the shoot.

One fact in connection with the use of petroleum, which I have never seen pointed out, must be duly considered in its application to Vines. It has been thought by some that the oil in a diluted state falling upon the soil does no harm, for it possesses slight manurial properties. The last may be the case, I cannot say, but they are not of sufficient merit to justify its use for that purpose. The injury to the soil is much greater than any advantage that can possibly follow its use. It turns the soil very black, and the roots refuse afterwards to enter it. It has a tendency to drive them down, and if the soil after its use is not carefully removed annually the roots will quickly disappear from the surface.

If the eradication of bug from our vinerias is followed up on the principle advocated for two or more years its destruction will be found a possibility.—WM. BARDNEY.



THE ROYAL HORTICULTURAL SOCIETY.—A special general meeting of the Fellows of this Society will be held at 2 P.M. on Tuesday, December 13th, in the Conservatory, to receive a report from the Council, and to consider the statements and proposals contained therein.

— THE SOCIÉTÉ NATIONALE D'HORTICULTURE OF FRANCE have arranged for a Horticultural Congress to be held at the rooms of the Society, 84, Rue de Grenelle, as in former years, during the annual exhibition in the month of May. All who are interested in the advancement of horticulture are invited to send papers for discussion. The Secretary is M. Ernest Bergman.

— AT their anniversary meeting on the 30th ult. the Royal Society awarded the COPLEY MEDAL to Sir Joseph Hooker in recognition of the services he has rendered as a traveller and botanist. The medal was presented by the President, Professor Stokes, who commented in complimentary terms upon the results of Sir Joseph Hooker's travels in the Antarctic regions, the Himalayas, Palestine, Morocco, and North America, and referred to his several excellent "Floras," together with his share of the great production "The Genera Plantarum."

— HIGH EXHIBITION HONOURS.—Last spring Messrs. Sutton consigned to Adelaide for the great Jubilee International Exhibition a splendid collection of seeds, and models of vegetables and agricultural roots, Grasses, Grass Seeds, and other articles bearing upon horticulture and agriculture, and they have received from Sir Arthur Blyth the gratifying intelligence that the Jurics have awarded them five first orders of merit, each carrying the highest prize medal. Mr. Martin J. Sutton has also personally received a flattering recognition for his excellent work on "Permanent and Temporary Pastures," the Jurics having awarded it a first order of merit and the highest prize medal.

— WE regret to see the announcement of the DEATH OF LORD HAWKE, who was better known twenty years ago in the horticultural world as the Rev. Edward Hawke, Rector of Willingham, Lincolnshire. He was an ardent florist of the old school. Lord Hawke died suddenly at the Midland Hotel, St. Pancras, on the morning of the 5th inst., at the age of seventy-two.

— SHOW FIXTURES.—The annual Exhibition of the Hull and East Riding Chrysanthemum Society has been fixed for Thursday and Friday, November 22nd and 23rd, 1888. At a meeting of the Portsmouth Chrysanthemum Show Committee on the 30th ult. it was decided that the Show next year should be open for three days—namely, the 7th, 8th, and 9th of November, 1888.

— THE Devon and Exeter Horticultural Society have fixed the following dates for their Exhibitions next year:—Summer Show, Friday, August 17th; Chrysanthemum and Fruit Show, Friday, November 16th. Both to be held at Exeter.

— AT a meeting of the CHISWICK GARDENERS' MUTUAL IMPROVEMENT ASSOCIATION, on December 21st, Mr. F. W. Burbidge will contribute a paper on "Plant Names." It may be remarked that Mr. J. Barry is the Hon. Sec. of this Association.

— AN article in the "Edinburgh Review" for October, entitled "RURAL FRANCE," contained some interesting particulars respecting the horticulture and agriculture of that country, and from which we extract the following:—"The Mulberry plantations of Gard or Herault, the wood of the Aisne, and the Flax of the Pas de Calais supply the raw material of the textile fabrics of France. 'Les Arbres de Normandie,' as Bernardin de St. Pierre called the Apple trees, produce cider in abundance; wines and spirits of all kinds and qualities are manu-



factured from Vines, Beetroot, or Potatoes; Hops supply the wants of her people, though the loss of the Alsatian provinces has reduced the growth; Olive yards and Walnuts produce oil for domestic use. France supplies the English markets with her early vegetables, the Asparagus of Argenteuil, the Artichokes and Broccoli of Rescoff, and the kitchen garden produce of the environs of Paris or the Nortillons of Amiens. Every grocer's shop in Europe contains her Almonds, her preserved fruits, her dried Apples, or her tinned vegetables. According to the season she floods Covent Garden with her Strawberries, Cherries, Pears, Apricots, and Plums, her Chassclas Grapes from Thomery, her Peaches from Montreuil, or her Melons from Vaucluse. Angers sends her flowers famous since the days of King René, and Grasse her perfumes to every part of the country."

— MR. E. R. CUTLER, Secretary of the GARDENERS' ROYAL BENEVOLENT INSTITUTION, informs us that "on Friday, the 25th ult., Mrs. Jane Atlee, widow of Richard Atlee, nurseryman at Stockwell, and many years gardener to H. Beaufoy, Esq., South Lambeth, died in her 100th year, pensioner of the Gardeners' Benevolent Institution since the year 1864."

— CARNATION PRIDE OF PENSURST AND MRS. G. HAWTREY — Mr. G. Goldsmith sends the following:—"W. G. D." writes, page 447 asking the difference between Carnations Mrs. G. Hawtrej and Pride of Penshurst. Not knowing the former I cannot tell him. If Mrs. G. Hawtrej was not introduced till six or seven years ago, how long previous to that time had it been in the possession of the florist a Sidmouth? In 1872 I remember seeing a large border of Pride of Penshurst in the gardens at Penshurst Castle, and was so struck with it that I prevailed on the gardener, Mr. F. Bridger, to give me a plant, which he did conditionally. Now if Pride of Penshurst has been in cultivation ever since 1868, as I believe, and Mrs. G. Hawtrej only the last six or eight years, and they are identical, in fairness to the raiser of the former by that name only should it be known, and not by the adopted name Mrs. G. Hawtrej. Perhaps the raiser of each variety will favour us with the desired information."

— AT a recent meeting of THE BELGIAN HORTICULTURISTS IN GHENT the following were present;—M.M. Léon Halkin, Ernest Delaruy, Em. de Cock, Louis de Smet-Duvivier, Baudu, Raph. de Smet, and Jules Hye, M. François Desbois presiding, and M. Edm. Van Coppenolle acted as Secretary. Certificates of merit were awarded for *Odontoglossum Alexandræ album*, from M. Edm. Vervæet et Cie; *Cypripedium Dauthieri striatum*, *Cypripedium cardinale*, and *Cypripedium vexillarium*, from the same; *Cypripedium Arthurianum*, from M. Jules Hye; *Cypripedium Bardeti* and *Cypripedium nitens*, from the same; *Odontoglossum Harryanum*, from M. L. Van Houtte; *Odontoglossum Insleayi splendens*, from M. James Bray; *Cypripedium eonchiferum*, from the same. Cultural certificates were awarded for *Oncidium varicosum* and *Calanthe vestita rubra oculata*, from M. L. de Smet-Duvivier; *Cypripedium Spicerianum*, from M. Louis Van Houtte; and *Sonchila Hendersoni argentea*, from M. L. de Smet-Duvivier. Honourable mention was accorded for *Cypripedium pleistochlorum*, from M. Edm. Vervæet et Cie; *Rhododendron hybride*, from M. Victor Cuvelier; *Cypripedium Harrisianum superbum* (flower), and *Cypripedium Spicerianum*, from M. Jules Hye; *Lycopodium pinifolium*, from M. Louis Van Houtte; *Odontoglossum grande*, from M. James Bray; *Cypripedium calurum*, from M. Fr. Desbois et Cie; *Dracæna rubra compacta*, from M. Louis de Smet-Duvivier; and *Angræcum sesquipedalee*, from M. Jules Hye.

— WE learn from Mr. James Douglas, the Hon. Sec., that the annual general meeting of the NATIONAL AURICULA SOCIETY AND NATIONAL CARNATION AND PICOTEE SOCIETY will be held, by permission of the Council of the Royal Horticultural Society, in the conservatory, South Kensington, as soon after twelve o'clock as possible on Tuesday, December 13th, 1887. The business of the meeting will be the election of officers and Committee, receiving the Secretary's and Treasurer's report, the election of Judges for the ensuing year, and any other necessary business as may pertain to the annual general meeting.

— "W. B." writes: "Mr. J. Jellico, Camp Hill, Woolton, exhibited at the Liverpool Chrysanthemum and Fruit Show, on the 29th and 30th inst., a basket of his HEARTING BORECOLE, which was very highly commended by the Judges. It is particularly curly and forms a close firm heart, more so than other hearting forms with which we are familiar.

It is after the style of 'Read's Hearting Borecole,' but the sample exhibited appears to heart earlier, and is firmer than that well-known variety."

— IN the article on EARLY FORCING, page 466, last issue, the word "branch," line fifteen from the bottom of the left hand column, should be "bunch."

— THE ANNUAL DINNER of the NATIONAL CHRYSANTHEMUM SOCIETY, as mentioned last week, will this year be held at Anderton's Hotel, Fleet Street, on Tuesday evening, December 13th. Chairman, E. Sanders, Esq., President of the Society. The Sub-Committee, appointed to make the necessary arrangements, have been very successful in securing most suitable accommodation, and also a liberal menu at a moderate cost. The tickets are 3s. 6d. each, and dinner will be served at 6 for 6.30.

— THE November part of the *Botanical Magazine* gives five plates representing the following plants:—T. 6963, *LANDOLPHIA FLORIDA*, a tropical African Apocynaceous indiarubber-yielding plant, which has been variously described under the names *L. comorensis*, *Vahlea comorensis*, and *Willughbeia cordata*. Living specimens were received at Kew in 1878 from Sir John Kirk. It is a tall climbing plant with large deep green leaves and dense clusters of white fragrant flowers.

— IN t. 6964 is given a figure of *PHALÆNOPSIS MARLÆ*, which was found by Mr. Burbidge in the Sulu Archipelago, and named in honour of his wife. It was found upon mountains, and possesses a very hardy constitution. The flowers are of medium size barred with reddish purple.

— THE new Mexican *POLEMONIUM FLAVUM* is represented in t. 6965, but it is not a plant of much beauty, the flowers of a yellowish white tint and large.

— THE next plate, t. 6966 is one of *MORINA BETONICOIDES*, one of the Dipsaceæ, and a native of the Sikkim Himalayas. It was found by Sir Joseph Hooker in 1848 at elevations of 10,000 to 13,000 feet. The flowers are rosy red with crimson blotches at the base of three lobes. The leaves are tapering, margined with long slender prickles.

— *VICIA DENESSIANA*, shown in t. 6967, is peculiar to the Azores, and even there much restricted in its area. The early buds are of a fine purple hue, changing to fawn and brown as they grow older.

— UNDER the title "ROSES FOR AMATEURS (L. Upcott Gill, 170, Strand), the Rev. H. Honeywood D'Ombraïn has published a manual describing his experiences in the selection and cultivation of Roses, and, as might be expected from such a veteran rosarian, it contains much useful information. It comprises sixty-four pages of small type, with several illustrations that are, however, the least meritorious portion of the book. The cultural instruction is clear, concise, and sound; a calendar of operations for every month in the year is given, and a full index adds materially to the usefulness of the production.

— WE learn with much regret that MRS. ELIZABETH MOORE, widow of the late Thomas Moore, died at the Botanic Garden, Chelsea, on the 27th ult. Mrs. Moore was in her seventy-third year, and it will be remembered that it is only eleven months since she lost her husband. She was buried on the 1st inst. in Brompton cemetery.

— THE first annual meeting of the SCOTTISH PRIMULA AND AURICULA SOCIETY was held at 5, St. Andrew Square, Edinburgh, on Thursday, the 1st December. The President, Mr. Cathcart, of Pitcairnie, being unavoidably absent, the chair was taken by Mr. Malcolm Dunn of Dalkeith Park. The Secretary and Treasurer submitted an interesting account of the Society's first Exhibition held in May last, which exceeded in extent the expectations of its promoters, although accidents in transit had deprived it of something like 150 plants. Financially the results were very gratifying, a satisfactory balance remaining in his hands. The Chairman congratulated the Society on the statement they had heard, and paid a well deserved compliment, which the meeting heartily endorsed, to the Secretary, to whose energy and courtesy the success of the movement is in no small measure due. In addition to a large and extended Committee the following gentlemen were unanimously re-elected to their respective offices:—President, Mr. R. Cathcart, Pitcairnie, Fife; Vice-President, Mr. W. B. Boyd, Faldonside; Treasurer and Secretary, Mr. W. Straton, Annfield, Broughty Ferry; Local

Secretary, Mr. James Grieve, Pilrig Nurseries, Edinburgh. Gratifying additions to the membership were announced. Mr. Straton intimated his intention of presenting a gold medal as one of the special prizes at the next competition, the date of which was fixed for Wednesday, 9th May, 1888. We are glad to report this good progress, and trust the Society will receive increased and continuous support.

— AN extremely attractive feature at the recent Twickenham Show was a GROUP OF TUBEROUS BEGONIAS from H. Little, Esq., The Barons, Twickenham, and it is so seldom that these plants are seen at late autumn shows that the following particulars from their exhibitor will be interesting. "The Tuberos Begonias were raised from seed obtained from my collection last season, and sown in heat in February of this year. I raised about 500 plants, and pricked them out as usual from pans, three or four in a small pot, then potted them singly and kept them growing, shifting into 48's and 32's. They flowered splendidly in pots, and carried on the season up to November, so that as my large specimens (with which we have been successful this year in gaining first each time we have shown them) went out of flower the forward seedlings were coming on into full beauty, and as the later seedlings came on they bloomed, extending the season in a most pleasant and satisfactory manner. Out of a sowing there are sure to be some seeds that germinate later than others; we save these and grow them on, and it is these later plants that bloom later. I am very pleased with this way of growing them, and have saved seed for next year."

— AT the same exhibition and from the same garden was a COLLECTION OF FRENCH AND AFRICAN MARIGOLDS IN POTS, which attracted much notice, and Mr. Little has obliged us with a note in reference to them. "These were treated as annuals and planted out in the open, but as they had not finished their flowering in October I had them taken up and placed into large pots with as large a bole of soil as possible, keeping them shaded for a short time. They did not suffer by the lifting, not losing a leaf, and they are now blooming with the Chrysanthemums in my conservatory in the most satisfactory manner, and we shall be able to save the seed of the best quality plants, while if they had been left out the early frost would probably have spoiled them. They have been much admired in the conservatory, and form quite a striking feature with their large orange and lemon coloured blooms that last quite as well as the Chrysanthemums. I shall certainly grow more of them next season for this purpose, as they give double pleasure by blooming in the open during the summer, and give autumn flowers for the little trouble of taking care of them in the way I have mentioned."

— GARDENING APPOINTMENT.—Mr. E. Hunt, recently gardener to the late R. H. Cotton, Esq., Etwall Hall, Derby, has been appointed gardener to the Rev. R. G. Buckston, Sutton Hall, Sutton-on-the-Hill, Derby.

— MR. J. MALLENDER sends his usual SUMMARY OF METEOROLOGICAL OBSERVATIONS AT HODSOCK PRIORY, WORKSOP, NOTTS, FOR NOVEMBER this year.—Mean temperature of month, 40.2°. Maximum on the 6th, 53.8°; minimum on the 18th, 21.5°. Maximum in the sun on the 5th, 97.0°; minimum on the grass on the 5th, 15.9°. Mean temperature of the air at 9 A.M., 39.2°; mean temperature of the soil, 1 foot deep, 41.3°. Temperature fell below 32° in shade on eleven nights, and on grass eighteen. Total duration of sunshine in month, fifty-four hours, or 21 per cent. of possible duration. We had ten sunless days. Total rainfall in month, 1.61 inch; maximum fall in twenty-four hours on the 5th, 0.31 inch. Rain fell on nineteen days. Average velocity of wind, 9.2 miles per hour. Velocity exceeded 400 miles on three days, and fell short of 100 miles on seven days. Approximate averages for November:—Mean temperature, 41.7°. Rainfall, 2.04 inch. Sunshine (six years), 53.5 hours. The coldest November since 1879. Rainfall less than in ten of the previous twelve years. The rainfall from the 1st of January is about 9 inches below the average.

#### NATIONAL CHRYSANTHEMUM SOCIETY. FLORAL COMMITTEE.

The last meeting of the National Chrysanthemum Society's Floral Committee for 1887 was held at the Royal Aquarium, Westminster, on Wednesday last, the 7th inst., when the following members were present:—E. Sanderson, Esq., in the chair, and Messrs. G. Stevens, R. Owen, C. G. Gibson, Lewis Castle, C. Swift, H. Cannell, G. Gorjon, T. Bevan, J. P. Kendall, and W. Holmes, Hon. Secretary.

The exhibits comprised several novelties, but only one Chrysanthemum

was considered worthy of a certificate—namely, J. Collins, from Messrs. W. and G. Drover, Fareham, a large Japanese of a bronzy buff colour with a tinge of yellow in the centre. Blooms of Lady Cave, a neat small creamy white recurring Japanese, were shown from Mr. R. Owen and were commended. The same exhibitor obtained the silver medal for a stand of new varieties, comprising Alcyon, Mawet Postula, C. Wagstaff, Anuie Roudière, Mrs. Norman Davis, M. Matheonnet, Ralph Brocklebank, Mrs. L. Castle, Putney George, Emilie Belloc, Le Dauphinois, and Lady Cave. Mr. G. Stevens was adjudged a bronze medal also for a very good stand, comprising fine blooms of Mr. H. Wellam, Lady Lawrence, Bomhardier, Mr. Addison, Mrs. Norman Davis, Ralph Brocklebank, and Lady Emily. The first named had rather the heavier blooms, but the latter was not much behind in merit, and the stand had a bright developed appearance. Mr. Sullivan of Rotherhampton sent a purplish scedling Japanese that was not thought sufficiently distinct. Messrs. W. & G. Drover, Fareham, sent blooms of their large Japanese variety bearing the name of the firm, but it was considered too coarse, though a smaller one, named H. Wat rer, yellow, with a reddish edge to the florets, was admired by some.

Mr. T. S. Ware, Tottenham, showed flowers of a bright yellow, late-flowering Chrysanthemum named Governor of Jersey, a Japanese with broad incurving florets. It is promising, and will probably be seen at the January Show. A vote of thanks was accorded to Mr. Taylor, gardener to Sir John Lubbock, Bart., High Elms, Farnborough, for a collection of Chrysanthemum blooms, and a similar award was accorded to Mr. J. Guyton, Station Road Nurseries, Belton, Great Yarmouth, for a sport from Princess Teck, named Jubilee, of which a large stand of blooms was shown. They were highly coloured, but the variety was not thought distinct enough for a certificate.

Messrs. H. Cannell & Sons, Swanley, showed a stand of new Zonal Pelargoniums, comprising some very handsome varieties, two of which were certificated—namely, Mrs. D. Saunders, large bright pink, with a white eye, the blooms beautifully formed; and Bridesmaid, very delicate and pretty, white, with a pale pink centre.

#### WINNING PRIZES—UNDER GARDENERS.

Now that the autumn shows are over and fresh in the minds of all, I think there is no more fitting opportunity to consider the position of under gardeners and how they are rewarded for the part they take in contributing to the success of many a prizewinner. There can be no question whatever that in gardens where produce is largely grown for exhibition, that an enormous amount of extra work must necessarily fall upon the foremen and other young men. In many cases they have all or the bulk of the work to do, and in order to accomplish this they may have to rise early and work late in the evening, so that the other work of the garden can be well kept in hand. How are they remunerated for this hard work, and the loss of so much of their own valuable time that is so much needed by them for reading and study? Do they share in the prizewinnings? The gardener in the majority of cases, I fear, gets all the credit and the prize money as well. This is not right, and gardeners would be the first to protest if they exhibited successfully and their employers demanded the prize money. Legally, no doubt, it belongs to the employer, but in most cases it is given to the gardener, or shall I say he is allowed to show and have what he makes? Is it right for the gardener to keep all that he can make from this source? It causes discontent amongst those who serve under him instead of contentment and a greater determination to be successful another year, which would result if they shared in what was made, or were remunerated in some shape or form.

I should be sorry to brand all gardeners with such selfishness as I have depicted, for I know some who are generous to their under men and annually make them a substantial present out of what they win. But I fear the greater number do nothing of the kind. I know cases where the young men have had to pay their own expenses, and in others have only been barely allowed their train expenses. It is utterly impossible to go to a show without incurring some expense, and I think this is both wrong and unjust when it is saddled upon those who do most of the work for which they receive no reward. Many a young man, perhaps never heard of, deserves the highest commendation for what he does and the part he takes in the preparation of produce for exhibition. It is to be hoped that those who have been successful throughout the year and have never given this matter thought or consideration will do so at once, and atone for the past by rewarding those under them for the assistance they have received.—A LOVER OF JUSTICE.



#### ONCIDIUM DASYSTYLE DR. WOODFORDE'S VARIETY.

SOME time since attention was called to this variety in the following note:—Many Orchid growers are familiar with the graceful and peculiar little *Oncidium dasystyle*, as the dark crest at the base of the yellowish lip much resembles the body of a bee. The plant was imported by Mr. B. S. Williams from the Organ Mountains, Brazil, and was figured in the "Botanical Magazine," May, 1880 (t. 6494), and the form there depicted has been that generally seen in collections until quite recently. Dr. W. T. G.

Woodforde, Oakbank, Spencer's Wood, Reading, has, however, forwarded a flower of a variety in his collection that is greatly superior to the ordinary type, considerably larger, brighter, and more delicate in colouring and marking. In the type first figured the flowers were  $1\frac{1}{4}$  inch in diameter, in this they are  $1\frac{3}{4}$  inch from tip to tip of the petals. The sepals and petals are three-eighths of an inch broad at the base, pale yellow, heavily and clearly spotted with purplish brown, especially at the base. The lip is of a delicate creamy yellow tint, is 1 inch in diameter, five-eighths of an inch across the centre from the base to the margin, slightly indented at the apex, uniform, contracted at the base into a narrow claw, with a dark purplish black rounded projecting crest, which has a curious effect in contrast with the pale tint of the other portion of the lip. The column has two rounded wing-like projections near the top, spotted at the inner surface with pale purple.

Dr. Woodforde has favoured me with the following particulars:—"I received it direct from Brazil (Rio Janeiro) two years ago, it being one of a parcel of some fifty Orchids brought home for me by my son, Dr. Sidney Woodforde. I was fortunate enough to have hardly any losses in starting them, and since then they have, without a single exception, thriven and done well in a cool 'general utility' house, size 30 feet by 10 feet (glazed on the non-puttying system and amply ventilated). They have had to put up with ordinary treatment, as the house also contains some young Vines and climbing greenhouse plants, as well as the usual contents of such a house in their various seasons. They have grown vigorously and flowered, some last year, while others which had not then suffi-

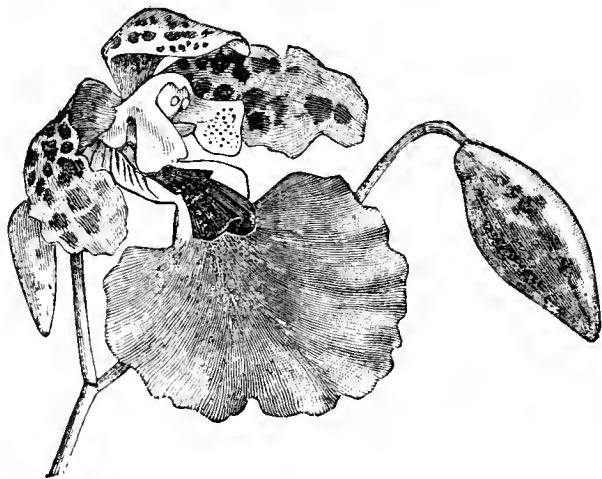

Fig. 53.—*Oncidium dasystyle* Dr. Woodforde's variety.

ciently established themselves have now done so, and promise well for bloom. In managing my Orchids I have been guided mainly by your admirable little book, with occasional references to Williams and other writers on them, and I need hardly say that they are a source of continual and daily interest to me. Last summer some plants of *O. dasystyle* of the ordinary type bloomed with me and are now flowering again or showing for bloom. The variety of which I sent you a flower has a spike some 22 inches in length, bearing eight blooms on the upper 8 inches. There is some little difference in the leaf of this and the ordinary kind." Sir Trevor Lawrence, Bart., M.P., Burford Lodge, has a variety resembling this, which was purchased last year at one of the sale rooms. H. M. Pollett, Esq., Bickley, also has a handsome variety, but differing from this in several points.

Since then Dr. Woodforde has sent a drawing of a portion of the spike, and one of the flowers from this represented in the woodcut (fig. 58). He also adds, "My plant began to flower early in July and continued in flower for four months—that is, till the beginning of November. The later flowers were on the secondary branchlets of the spike, the main stem of which was 22 inches in length, and had eighteen flowers. The last blooms were quite as large and bright as the earliest ones, and the plant continues in vigorous health."

#### ONCIDIUM CHEIROPHORUM.

THIS is a dwarf-growing compact Orchid, deserving a place in the most select collection. The flowers, which are produced during the winter months on upright branching spikes, are a charming yellow colour and remain in beauty for a long time. To succeed with this, it should be potted in peat and sphagnum with liberal drainage and grown near the glass at the coolest end of the Cattleya house. There are some splendid plants in flower at the present time under the above treatment in the collection of Edward Ellis, Esq., Manor House, Wallington. They are in 6-inch pots, each carrying eight spikes with scores of sweet-scented flowers. In the

same house, too, are numerous spikes of the showy *O. varicosum*. Of *O. tigrinum* there are several forms, the best a good dark variety bearing thirty-eight blooms on a branching spike. The plants are suspended from the roof, and in this manner the graceful arching spikes are seen to perfection. *Masdevallia tovarensis* in 8-inch pots are in fine health, and will soon be in a mass of white bloom. *Calanthes* also are showing well, some of the flower stalks having a leaf-like appendage. In the cool house the lovely *Odontoglossum madrense* has been in bloom for more than three months, and *Masdevallia amabilis* in a large specimen has been continuously blooming for the whole year. All the Orchids are doing well under the care of Mr. T. Glover, the gardener.—W. G. C.

#### CALANTHES IN BASKETS.

MUCH is written about *Calanthes* and their culture, and I think too much cannot be said in favour of these lovely winter Orchids, for few plants attract more admiration than *Calanthes* when well grown. As a rule, I think gardeners generally grow them in pots only. At Raby we make a specialty of *Calanthes* in baskets as well as in pots, and as a basket plant I wish to pass a few remarks upon them. *Calanthes*, when grown in pots, lose that graceful appearance that they have when hanging from a basket. We have about sixteen baskets of *Calanthes* over a path in the plant stove with ten and eleven spikes in each basket. I measured one of the finest recently, and it was 5 feet 7 inches long, with fifty-three blooms, and not at its full length yet. We hang one basket of *C. Veitchi* and then one of *vestita*, and so on alternately. Each side of the path we have Ferns and different foliage plants, so that the green foliage underneath helps to show the colours of the flowers. I might mention that many of our pseudo-bulbs this year are flowering from the top as well as at the base. We have two distinct varieties of *C. Veitchi*. The colour of one is much darker than the other, and the flowers are produced much more closely together. The pseudo-bulbs also are quite distinct. In the light variety the pseudo-bulbs have an indentation as if a piece of string had been tied tightly around them; the darker variety loses the indentation, and the pseudo-bulbs are quite straight. We consider the dark variety by far the better, still we like to keep the light one as a contrast. Those that have not yet tried *Calanthes* in baskets and have room to grow them should certainly do so next year.

We re-basket our *Calanthes* about the middle of February, and grow them in a temperature from 65° to 70°, with a slight shade in summer. We first line the basket with sphagnum moss. We then mix a compost of fibrous loam with a very little Orchid peat, some cow manure that has been dried before so that it will break readily, and some sphagnum moss, with plenty of charcoal and rough sand. We shake all the small soil from the loam and use only the fibre. We plant the pseudo-bulbs well above the rim of the baskets, not too firm. We give them very little water till they are fairly started, then we feed them with liquid manure made from deer dung till they show their flower spikes, say about 3 or 4 inches long, then we gradually withhold water till they become quite dry. We leave the pseudo-bulbs in the baskets until we again re-basket them in February.—JAMES TULLETT, Foreman, *The Gardens, Raby Castle, Darlington.*

#### APPLE TREE ENEMIES.

HERE we have, foremost, the notorious American blight, which everybody knows. This insect is said to retire into the ground during the winter, and to prey on the roots during that dormant period, and there seems no reason to doubt it. I have never attacked it under those conditions, but I do think that its position is anything but secure if we were to betake ourselves earnestly to its extirpation. I was sorely troubled with this pest two or three years since; and last autumn I had become almost heartless at the serious appearance of many of our Apple trees. I had repeatedly applied spirits of turpentine to the larger patches, and had, in a great measure, conquered them in the nooks and crannies; but they had, in many cases, completely invested the upper twigs, or young wood; and I dare not pursue them all over the tree, knowing, by experience, that much turpentine is highly prejudicial to the tree.

As soon as the leaves were falling—about the first week in November—I had the trees syringed heavily twice over, on two successive days, with a mixture of softsoap, water, and stable liquid, using four ounces to the gallon of soap, the stable liquid constituting nearly one-half. This was made to saturate every cranny of the trees, and so profuse was the application that the soil was completely caked with the falling liquid. I am of opinion that the blight was then near the surface of the soil, and, if so, doubtless numbers would be destroyed. I have now nearly cleared the whole garden of this pest, having applied spirits of turpentine the moment a patch appeared through the summer. I shall, however, repeat the dose, and hope to report an entire clearance. Our trees, formerly the admiration of all, presented such a bare appearance last September that I almost despaired of getting a good crop again; but I have gathered at least 50 bushels from the mere espaliers of the kitchen garden, and finer samples were never seen.



Another sad pest of the Apple tree is a rusty looking fungus, which generally occurs towards the end of August. This, when it once commences, seldom ceases whilst a green leaf is left on the tree, which ultimately appears as though it had been scorched. I am not aware that any remedial measure is known. It is rather a matter which, beyond doubt, may be in the main prevented, and to which course I will shortly refer.

Another serious pest of the Apple is the red spider, especially on hot or gravelly soils. And here it may be observed that since sulphur is known to be destructive of the fungi in general, also to the red spider, and as these two enemies generally commence operations about the same time, and not unfrequently act in concert, it is well to remember that much may be done by the timely application of sulphur.

Here I would remark on the vast influence exercised by certain soils as a predisposing cause to insects. I am well assured that all soils which

otherwise the evil must be sought in other quarters. When these evils are suspected to arise from a soil or subsoil highly retentive of moisture, nothing short of drainage can be expected to cure the evil; and this, probably accompanied by transplanting. Indeed, in all cases of amelioration by means of draining, where trees are standing, it is well to take them carefully up and to replant them, although they may have been planted half a dozen years. Where soils have been soured by stagnant moisture they seldom gain a healthful condition without being broken up.

Thus much for soils as affecting the mishaps that occur through insects or fungi; let us now see what remains as to this question. Whether Apple trees have been attacked or not in the previous summer, it is well, in my opinion, to give them an annual dressing of some kind. Our great orchardists, our men of acres, will, of course, say it is impossible; but we of the garden must not allow ourselves to be hedged in by their rough and off-hand plans. It is rather for us to lead them than the reverse, and it is sometimes expedient to do that in a few poles of land, that would cease to be so in as many acres. Besides, we have a more delicate and very superior class of fruits to deal with than they have, and it is probable that our superior dessert Apples would, as dwarfs, make no great show in a cider district with cider Apple management.

We all know that brushing in compositions is tedious work, especially since labour has become so much more valuable; but there is no need for it as to a general dressing. If I may suggest annual dressings by means of the syringe, and supposing it requisite to meet as many of the enemies of the Apple as could be in one mixture, it should be composed nearly thus:—softsoap, 4 ounces to the gallon of tepid water; add four handfuls of sulphur to each gallon; then add 1 gallon of stable liquid, and thicken the whole finally to the consistence of a thin paint by the addition of clay water, made by working up clay in tepid water and straining it through a coarse cloth; a few handfuls of lime may be added. With such a liquid I would have the trees syringed twice; once in November, when the foliage is nearly all cast, and a second time in the beginning of March, after the trees are pruned. This, I think, will prove of eminent service, and will destroy the coccus, or scaly insect, as well, which I had forgotten to name in its proper place, and which is occasionally a great injury to Apple trees.—R. E. N.

#### SCHUBERTIA GRANDIFLORA.

ON September 13th this year, A. C. Bartholomew, Esq., Park House, Reading, exhibited a specimen of this plant at South Kensington, when the Floral Committee of the Royal Horticultural Society awarded a first-class certificate for it, as, though it is not a new plant, is seldom seen in cultivation. It is a member of the *Asclepias* family, and a native of the Argentine Republic, whence it was introduced in 1837. The stems are long, slender, and twining, bearing the opposite leaves in pairs, elliptical in form, about 6 inches long by 3 broad. The flowers are borne in axillary umbels of seven or eight, the pedicels covered with brownish hairs; the corolla five-lobed, 3 inches in diameter, white, with a few scattered hairs, and possessing a powerful odour, most agreeable at a short distance.

This and the allied species, *S. graveolens*, with yellowish flowers, require a stove temperature and a compost of one-third light turfy loam, with two-thirds of peat and a little sand. Plenty of water is needed while they are growing, with occasional syringing, and attention to keeping them clear of insects, especially mealy bug. They can be propagated by cuttings of the young side shoots inserted in very sandy soil in strong bottom heat.

#### TOBACCO CULTIVATION IN ENGLAND.

A CONFERENCE of English Tobacco growers was held recently at the Salisbury Hotel, Salisbury Square, Fleet Street, under the presidency of Sir E. Birkbeck, M.P. Among those present were—Mr. Kains-Jackson, Mr. Faunce de Laune, Mr. Sharman (Carter & Co.), Mr. C. C. Knight (Farnham), Mr. Wigan (Kent), Mr. John Graves (Boston), Mr. Kerr (Dumfries), Mr. Moore (Chelmsford), and the Rev. Wyndham Madden (Kent). Specimens of English-grown Tobacco, as well as cigars and cigarettes manufactured from Tobacco grown in different parts of the United Kingdom, were exhibited in the room. After a short discussion,

The Chairman said that they all must be agreed that they had to contend against many obstacles, difficulties, and novelties. With regard to the present season they had a very dry summer, followed by a cold and damp September, besides which, he was sorry to say, they had encountered many difficulties with the Inland Revenue authorities, though he was bound to add, as regarded his own district, that the Inland Revenue had rendered him every possible assistance. Among the growers there was more than ever a spirit of determination to persevere with Tobacco culture in England, and they were convinced that they would ultimately be able to master all the difficulties they had had to contend with. He believed that in the future Tobacco culture in England could be made as successful as it was 200 years ago, when it was prohibited by Act of Parliament. As regarded his own crop he would simply say that he had grown four sorts during the year—viz.,



Fig. 59.—*Schubertia grandiflora*.

have a tendency to become very dry, or very wet, for a long while, predispose the Apple to the attacks of insects. How this happens I am not prepared to aver; but suppose that under such circumstances a torpid or sluggish root-action occurs, and, of course, the system of the tree possesses sap of a less watery character. Thus, a newly planted tree, of a good size, is almost sure to be liable to the attacks of insects or fungi the first summer; and so with over-severe root-pruning. This all points to the propriety of examining well the state of the soil before planting a tree or an orchard, and taking means to correct the extreme tendencies to dryness or sourness through a too retentive character.

But in very sandy and dry soils the water-pot will prove of eminent service to the Apple if used in time. It is of no use merely sprinkling; nothing less than a thorough penetration of the whole mass of soil which contains the roots will suffice. And if a thick coat of moist mulch of any kind can be applied, the success will be proportionately complete, the mulch being laid 4 inches in thickness. This should be performed the moment the insects or fungi appear, providing the weather is dry;

the Virginian, the Big Frederick, the Kentucky, and the Yellow Prior. He had been rather severely criticised by Mr. Kains-Jackson because he had topped his Tobacco, reducing the number of leaves to about eight, but he felt it was far better to have a small number of leaves with better quality than to have more leaves and an inferior quality. For some reason or other this year the curing of his Tobacco had been far easier, the leaves had turned much quicker, and he had not had the difficulties that were usually met. This might have been in consequence of his having utilised a malt house for curing the Tobacco. He suggested that growers of English Tobacco should take into their consideration the question of having a central bonded warehouse in London where they could send their crops when they were dried, so that they might be under the control of one or more competent persons. The warehouse would be an immense help to the Inland Revenue authorities, inasmuch as they would only have to watch one warehouse instead of numerous premises; and when any grower desired to remove his Tobacco to sell it he might be allowed to do so. He had received a letter from Lord Walsingham expressing great regret at his inability to be present, and enclosing an account of the culture of a quarter of an acre of Tobacco at Merton, in Norfolk. It was Lord Walsingham's opinion that Tobacco of commercial value could be grown in England in many varieties. He would merely add in conclusion that he could see no right or justice in maintaining the duty on home-grown Tobacco.

Mr. Kains-Jackson said that in the month of September last he sent out to the chief Tobacco-growers in England a series of questions with respect to their modes of culture and the methods they adopted for curing the leaf, and he had received in many cases most interesting answers, which, if printed, would form a most useful book. The London Chamber of Commerce were offering two prizes of £50 each, one for the best specimens of foreign-grown leaves and the other for those of home-grown.

Mr. Wigan, Mr. Knight, Mr. Greaves, and Mr. Madden having related their experiences in connection with home-grown Tobacco,

Mr. Sharman said that with regard to the cultivation of Tobacco by Messrs. Carter this year, they had had something like sixty-four varieties. They had sent to every quarter of the globe and had obtained every possible variety of seed, and as far as he could see they had not made any very great mistake as to the sort which they had already stated to be the best for general cultivation in this country. The yellow Tobacco would no doubt pay better than the darker sorts, and the Kentucky and the White Burley, and, for bulk, the Big Frederick and the Connecticut were perhaps the best. In his opinion the home-grown leaf was essentially a cigar leaf and not a pipe leaf.

After a short discussion it was decided that a Committee should be formed to arrange for an adjourned meeting, to authorise the printing of such reports as might be considered useful, and to consider the question of a central bonded warehouse for maturing and perfecting the crops, and the desirability of drafting a Bill to lay before Parliament as to the conditions under which Tobacco land in the United Kingdom might be cultivated; the Committee to consist of Lord Walsingham, Sir E. Birkbeck, Mr. Kains-Jackson, Mr. Faunce de Laune, and Mr. Wigan.

The proceedings closed with a vote of thanks to the Chairman.

We learn that the Tobacco grown last year by Lord Harris at Belmont was recently destroyed by fire by an order of the Board of Inland Revenue, and in the presence of one of their officers, in consequence of its being considered unfit to pay the duty. This year's growth has been dried in a hop-oast, and still hangs there, but the opinion of those who have been privileged to inspect it is that it will never be fit to smoke.

#### HEXHAM NURSERIES AND GARDENS.

CHRYSANTHEMUMS and the records of the very numerous exhibitions devoted to them have occupied so much space in the Journal during the past few weeks, and have occasioned so much journeying, that there has been little time or opportunity for continuing notes on gardens in the north. Some friends have even become concerned at the abrupt termination of these contributions, and have been kind enough to express a hope that something farther might appear on the subject. For their satisfaction I have therefore given the preceding explanation, and may also add that I had neither concluded my notes nor exhausted my memory respecting the places visited in the north, and I should have been most unwilling to omit several establishments that have yet to be described.

Hexham is readily reached by rail from Newcastle-on-Tyne, and is about twenty-one miles westward of that city on the line to Carlisle. It is a small town of some historical interest, and its pleasant situation near the junction of the North and South Tyne renders it an agreeable resort for tourists in Northumberland. The vale of Hexham is noted for its beauty and fertility in the north, and though the scenery is not so boldly picturesque as around Rothbury, it is of a thoroughly English character, varied and rich in vegetation. From several of the hills extensive and delightful prospects can be obtained, and during the summer months a pleasant holiday could be spent there. Hexham itself is not of any great importance now, and the guide books tell us that it has for some time been chiefly celebrated for the manufactories devoted to the production of gardeners' gloves, or "Hexham Tans," as they are termed; but to horticulturists its chief interest is due to Messrs. Fell & Co's. extensive nurseries, and the surrounding residences, such as Duke's House and Beaufront Castle, which well repay for a visit, as they are

most beautifully situated. The nurseries named are, however, of such importance that they deserve the first attention.

#### MESSRS. FELL & CO'S NURSERIES.

It is always pleasant to visit a well-kept and well-stocked nursery, and the establishments occupied by the above-named firm unquestionably fulfil these conditions, and they have deservedly obtained a substantial reputation. Forest and ornamental trees, Conifers and shrubs, constitute the leading features of the Nurseries, and these are grown by millions, but fruit trees, hardy herbaceous plants, and vegetables for seed also occupy considerable space, the business comprising, in addition, a large northern seed and bulb trade. The Wentworth Nursery is that nearest to the station, and is devoted mainly to ornamental plants, shrubs, and trees; the Prattsfield Nursery contains the fruit trees, with the farm and vegetable seed trials; the Fellside and Hudshaw Nurseries upon the hill slopes on the southern side of the Valley, rising to a height of nearly 600 feet above sea level. The last two are devoted to the stock of seedling Conifers and forest trees, enormous numbers being grown, as can be judged from the fact that the firm was able some time since to undertake the contract for the supply of 300,000 trees for the extensive plantations in the Isle of Man. The soil and situation are admirably adapted for the production of sturdy, hardy trees—the ground sloping to the north or north-east exposes the plants sufficiently, especially at such an altitude, to prevent any danger of their being delicate or drawn. There is also sufficient protection to avoid undue check, that soon results in stunted growth from which trees seldom recover. Weakly and stunted seedling trees are most unsatisfactory in all respects, and perhaps after waiting several years it is found that they will never make symmetrical specimens or good timber. Whether planting on a large or a small scale, the selection of healthy young specimens that have been properly prepared by frequent transplantation is of the greatest importance. Messrs. Fell & Co. evidently give close attention to these matters, and even in such a tropical summer as the past it was surprising to observe, when inspecting the large quarters of Pines, Larch, &c., how fresh and healthy they all looked, showing the good effects of judicious cultivation and thorough cleanliness, for weeds are not tolerated in these establishments, and they are quite models in this respect. Several of the young trees were lifted to show the character of the roots, and they were in every instance dense masses of fibres of the most satisfactory kind. Of Scotch Firs, Austrian Pines, Larch, Spruce Firs, and all the principal deciduous forest trees, there are hundreds of thousands in excellent condition, and the seed beds, containing great numbers of the preceding for future supplies, were like neatly kept lawns, so even and close were they. The view from the upper part of these grounds is exceedingly beautiful, and I remember but one nursery that affords a similarly extensive prospect—namely, that of M. M. Jacob-Makoy at Liège, where, from a kind of observatory on one of their houses, a fine prospect is obtained of the town and the Meuse Valley. At Hexham it is somewhat similar, but the landscape is not obscured by so much smoke as in the Belgian town.

Returning to the two establishments in the lower ground the Wentworth Nursery first claims attention. The entrance to this is immediately opposite to and facing the railway station. The main avenue running right through the nursery from here is 18 feet wide, flanked by borders 9 feet wide, on each side containing an assortment of choice Conifers intermixed with foliage and ornamental trees. Sections of young Conifers, such as Cupressus Lawsoniana, and its varieties lutea, grævilis, and erecta viridis, Retinospora plumosa and plumosa aurea, Thuiopsis dolabrata, and Biota elegantissima, with Aucubas, &c., being tastefully grouped together on both sides of this avenue; while in front a good effect is produced with an edging of Dactylis glomerata elegantissima aurea. Again artistically arranged behind these on each side are some specimens of Conifers and other leading sorts, including some fine specimens of Thuiopsis Standishi, Thuia Vervaeiana, Taxus elegantissima, Taxus aurea, Widdringtonia cupressoides, Taxodium distichum, Podocarpus japonica, Cedrus Deodara, Biota aurea and elegantissima, Picea Nordmaniana, &c., &c. Diverging from the main avenue we find on each side large breaks of Roses (upwards of 17,000 being grown), while Gooseberries, especially Whinham's Industry, which has been illustrated in this Journal, is a speciality, large breaks of this variety being grown to supply the ever-increasing demand for it, not only in the United Kingdom but for continental markets, the United States, and Canada. Over 53,000 bushes of this variety were sent out last season. Hundreds of thousands of Thorns for fencing purposes are grown here, as well as in other portions of the nurseries, as large contracts are executed for the different railway companies. There are large breaks of seedling and transplanted Beech, Ash, Sycamore, Oak, Scotch and English Elm, Chestnuts, Poplars, Limes, (Gold and Silver Elders are grown in quantity, suitable for seaside planting), while a large breadth of ground is devoted to specimen ornamental trees for parks and avenues planting, including some fine specimens of Purple and Fern-leaved Beech, Weeping and Cut-leaved Birch, Scarlet Oaks, Double White and Scarlet Horse Chestnuts, Red-twigged and Fern-leaved Limes, and Maples. The collection of hardy plants comprises most of the thoroughly useful species and their varieties, all the best being grown in large numbers.

A number of specimen Conifers are grown in tubs and pots for employment in the decoration of large buildings and pavilions at exhibitions. During the past season the firm was entrusted with the decoration of the Prince of Wales' Pavilion at the Royal Agricultural Society's Show, Newcastle-on-Tyne, also with a similar charge at Blagdon Hall, the seat



Of Sir M. White Ridley, where the Prince stayed during his visit to Newcastle. At the Royal Jubilee Exhibition in the same city similar and smaller specimens were employed in some of the large central courts with excellent effect, which was considerably heightened by the admirable lawns. Many of the choicest Conifers can be so employed in corridors and cold passages where few other plants succeed. In some cases, too, a system like that at Cragside, which has been previously noted, could be advantageously tried—namely, enclosing the beds devoted to the choicer or more tender Conifers with glass sides open at the top, but so constructed that lights could be placed on in severe winters.

The Prattfield Nursery includes some capital young fruit trees, both trained and standards, Apples being extensively represented by a selection of the varieties that have been proved best adapted for the northern counties. A comparatively new Apple that is much esteemed in the north, especially in Scotland, is the Beauty of Moray, to which Messrs. Fell & Co. have given some attention with good results, as several gardeners have tried it and speak favourably of its merits as a culinary variety of hardy constitution and as a good keeper. At the Chiswick Congress in 1883 it was only shown by one exhibitor, Mr. G. Welster, The Gardens, Gordon Castle, Fochabers, N.B.; and Mr. A. F. Barron thus describes it: "Large, round, angular, greenish yellow, mid-season; a favourite Apple in the north of Scotland." It seems likely to be particularly useful in exposed situations, as I saw healthy fruitful young trees of it at Sunderland, where the number of varieties that will succeed is very restricted. The houses for propagating purposes are chiefly in the Wentworth Nursery, and there the choicer Conifers, are increased, together with a miscellaneous collection of indoor plants. Extensive packing and storing sheds, offices, &c., together with a seed office in Priestpottle Street, complete the numerous departments of this firm. It need only be added; that in all abundant evidence is afforded of the energetic business-like system adopted by the courteous partners Mr. Fell and Mr. Milne, and their experienced manager, Mr. Brown.—L. CASTLE.

### CHRYSANTHEMUM NOTES.

#### CHRYSANTHEMUMS AT WOODCOTE HALL.

THE REV. E. W. NORTHEY with his usual kindness gave the inhabitants of Epsom and district the privilege of inspecting his Chrysanthemums so successfully grown by his gardener, Mr. T. Pledger, last Thursday and Friday. The plants are arranged in the conservatory, which is 65 feet in length by 21 feet, and was illuminated at night with lamps and Chinese lanterns. The cutting down system has been adopted with the result that all the plants (450 in number) are dwarf and compact and feathered with bright green foliage to the pot. The tallest, not exceeding 4 or 5 feet, are grouped together on the floor right through the centre among some finely trained Camellias planted out, the dwarf ones, 1½ foot to 3 feet high, occupying the stages all round. There are three rows of these, and in front are two rows of well flowered single Primulas, red and white. Madame C. Audiguier has some well developed blooms on plants only 3 feet high; Comte de Germiny, with large and well formed flowers, equally dwarf. Among the best Album plenum was very conspicuous. Boule d'Or, Baronne de Prailly, Balmoreau, Dr. Macary, Étoile du Midi, Hiver Fleuri, Meg Merrilies, Mdle. Lacroix, Peter the Great, Triomphe du Nord, Jeanne Delaux, M. Desbrieux, Thunberg, Val d'Andorre, Madame B. Rendatler are also good. The Japanese Anemone-flowered and some of the best incurved varieties are well represented. There was a continual stream of visitors on both evenings, including many growers of this popular autumn flower.—G. W. C.

#### CHRYSANTHEMUMS AT EAGLE HOUSE, DOWNHAM, NORFOLK.

BEING invited to see these very popular plants in flower I availed myself of the opportunity, and spent a very enjoyable hour amongst them. My friend told me his flowers were creating a sensation; well they might, for they were fine clear blooms fit for any exhibition table. The Japanese were in very fine form, and I send a few names of the best. Belle Paule, Comte de Germiny, Elaine, very large; Ferdinand Feral, Fair Maid of Guernsey, Japonaise, Madame C. Audiguier, M. Astorg, Mdle. Lacroix, Mr. John Laing, Thunberg, Lady Hardinge, Lord Alcester, Mr. George Glenny, Queen of England, Golden Empress, Cullingfordi, a noble flower; Mrs. Forsyth, Sœur Dorothée Souille, Madame Cabrol. Anemone-flowered was very conspicuous. Madame B. Rendatler, Jeanne Delaux, Mabel Ward, King of the Crimsons, very fine reflexed; Soleil Levant, good yellow; Mrs. G. Rundle, and Mrs. Weston. It is not a very long list, but what I take to be of the best of the numerous varieties now grown. Mr. Strong is an old hand at Chrysanthemum growing, and he has done well.—S. C.

#### JUDGING AT SHOWS.

AT the late Chrysanthemum Show held in Manchester a most curious circumstance occurred in making the awards, and to me a most incomprehensible one—namely, in five classes as many as six equal prizes were given, which means that twelve persons were awarded prizes, whereas five only should have had them. Such results show that the exhibits must have possessed a most wonderful likeness to each other in all points, or the only other reason I can account for it was a lamentable ignorance on the part of the judges appointed to adjudicate on these particular classes. I am not a believer in equal prizes only in very exceptional cases where the points of comparison are very few in number. Certainly in Chrysanthemum cut blooms, where so many points

are involved, there should be no equal firsts, or any other grade, but more particularly first prizes. For instance, I do not think it is possible for judges to make two stands of, say, twenty-four blooms equal; if by chance it does occur when the blooms are gone over and judged by the point method the first time, then the judges should start at the opposite end—that at which they finished—and if they should by any chance arrive at the same total of points again, which is hardly likely, the judges should look for an extra point in the setting up of the blooms, arrangement of colours, and so on. These two points are surely worth some consideration in all cases, much more so in close competition. I look upon the award of equal prizes as loopholes for the judges to get out of a difficulty to determine by a little more labour which are really the best stands. We do not notice so very much one or even two equal prizes, but when as many as six are awarded in five classes there is reason to question the ability of the judges. The best security for the continuance of good exhibitors at any show is the appointment of competent men to judge their products; and in these days of competition, where societies are so numerous and prizes so valuable, exhibitors have the remedy in their own hand, that of going where they know justice will be dealt out to them. Therefore all societies should bear this in mind, that the appointment of qualified judges gives a popularity to their exhibition amongst competitors, and these persons are not the last to consider in prolonging the welfare of any society.—AN EXHIBITOR.

#### MRS. NORMAN DAVIS.

CONSIDERING the limited time at his disposal and the crowd of visitors in St. George's Hall, it is surprising your reporter gave such a full and good account of the Liverpool Show as appeared on page 477 last week. In that report reference was made to the new Chrysanthemum Mrs. Norman Davis; but the exhibit merits a little further notice. Three or four round flat baskets were filled with blooms containing probably as many hundreds, massive, broad petalled golden globes, fresh, bright, and beautiful, proving to demonstration how admirably the variety is adapted for late exhibitions and decorative purposes. It is questionable if such a display of yellow Chrysanthemums, or indeed of any other variety, has been hitherto seen at a public exhibition.—W.

#### AMY FURZE.

THIS variety has been more than once certificated as a reflexed flower, but it only comes within that designation when in a young state and the florets are flat and imbricated. As the blooms get older, and especially when grown large on strong plants, the florets become more or less revolute, spreading, and distinctly arching, exactly in the same manner as in some of the Japanese varieties. In that form they are quite dissimilar in their essential character from recognised reflexed blooms, and cannot do otherwise than weaken the stands of these considerably. Very large blooms of Cullingfordi lose their reflexed character, but the departure is rarely so marked as in the case of Amy Furze; and if these varieties are included in reflexed stands they should be young, as size is only attained at the expense of character, and when they assume the tasselled form they will be either passed or lose points with most adjudicators. Both varieties are excellent for decorative purposes.—A JUDGE.

#### THE HULL CHALLENGE CUP.

I AM sorry if I have hurt Mr. Udale's feelings. Such was not my intention. I merely wish to make the matter clear to the readers of the Journal, and to do this it is unavoidably necessary for me to draw attention to what I conceive to be the weak points of Mr. Udale's letters. If my amendment to Mr. Udale's suggestion is comparatively worthless, surely his suggestion is still more so, as if carried out it would actually prevent executors from carrying on a competition, and the absence of any provision to enable them to do so was the only obstacle to our Committee allowing the late Mr. Neumann's executors to count last year's win. The clause I have suggested would, should a similar case arise again, allow of a previous year's win remaining to the credit of a deceased competitor's executors. Mr. Udale claims to have been supporting Mr. Mease's case, but if the former's suggested clause had been in force it would have entirely shut out the latter from winning the vase finally this year for Mr. Neumann's executors, which the action of our Committee has enabled him to do; such action, I may remark, having been taken immediately the legal difficulty was removed. Throughout this matter none have had more friendly feelings towards Mr. Mease than have the members of our Committee. I think the readers of the Journal will now have had enough of the subject. This, therefore, will be my last communication on the topic, and nothing remains but for me to thank the Editor for allowing it to be freely ventilated.—R. FALCONER JAMESON, Chairman Hull and East Riding Chrysanthemum Society.

#### CHRYSANTHEMUMS AT WALTON LEA.

WALTON LEA is the residence of John Crossfield, Esq., and is about two miles from the busy town of Warrington. Mr. William Kipps has for many years been in charge of the gardens, which are admirably kept, his object evidently being to do whatever he undertakes well. He is known as a competent judge of Chrysanthemums, and was at one time an exhibitor at the Liverpool shows, but during recent years he has devoted his attention to providing home exhibitions, and the pleasure of these has, by the consideration of his employer, been shared in by such of the inhabitants of the contiguous town as took advantage of the opportunity that was afforded on the two appointed days for a public inspection. The privilege appears to have been warmly appreciated, for upwards of two thousand persons attended.



The display was worthy of the occasion, two fine groups of plants being arranged in the spacious conservatory adjoining the mansion. The plants ranged from 3 or 4 to 6 or 7 feet high, and comprised the leading varieties. As groups they were of a first prize character, while many of the blooms were of sufficient merit to be arranged in the best exhibition stands. A third group was composed of twenty specimen Pompons, not closely tied, but free yet compact, the plants ranging from 2 to 3 feet in diameter, and were semi-globular masses of colour. On the side sills were plants about a foot high and nearly the same in diameter, in 5-inch pots. Several cuttings were inserted in the pots in August, and the plants almost resembled bouquets. Other features at Walton Lea merit notice, but in the meantime it must suffice to congratulate Mr. Crossfield and his gardener on the excellence of the Chrysanthemums that have been so much and deservedly admired by all who have seen them.—A VISITOR.

#### EDINBURGH CHRYSANTHEMUM SHOW.

THE Scottish Horticultural Association had a Show of Chrysanthemums last year, on a small scale, and were so successful that this autumn it was determined to take the Music Hall in George Street—where the Royal Caledonian for so long a time was located—and there hold a two-days Show, on November 29th and 30th. The Council did not provide any large prizes; but, notwithstanding, they induced exhibitors to come from all parts of Scotland—from as far south as Berwick, north to Aberdeen, while from the west came the best blooms in the Exhibition. All the classes were well filled. In the popular classes from seven to fifteen exhibitors staged for the prizes. Japanese were shown to the greatest perfection, the incurred being most deficient in finish. The chief prizetakers were Mr. Hepburn, gardener to W. F. Burnley, Esq., Erieh Bank, Dunoon; Mr. McChattie, gardener to Marquis of Lothian, Newbattle; and Mr. Grossart, gardener to J. Buchanan, Esq., Oswald Road, Edinburgh. The plants were less noteworthy than the cut blooms, and were generally tall and bare of foliage.

Besides the competition exhibits most of the Edinburgh nurserymen contributed to the Show, Messrs. R. B. Laird & Sons showing most extensively. Mr. Carruthers, gardener, Hillwood, Corstorphine, had also a good collection of some six dozen blooms for exhibition, the high quality of which attracted much attention. There was also a fair display of fruit sent from various growers, Grapes and Apples being most noteworthy. Financially the Show was a success, as about £30 was cleared. A Chrysanthemum Exhibition was also held in Dumfries on the 30th, and one at Dundee on December 2nd and 3rd.

#### LEEDS PAXTON SOCIETY'S SHOW.

THE annual Exhibition of Chrysanthemums in connection with the Leeds Paxton Society was held in the Society's Room, the "Grand" Restaurant, Boar Lane, on Saturday last, December 3rd, and was in every respect a great success. No prizes were offered, but this did not deter the members from bringing their choicest flowers in abundance, the result being a display which would not have disgraced any Exhibition, and must have been highly satisfactory to the Executive, who work hard throughout the whole year to make the Society's meetings instructive and interesting to all. Additional interest attached to the exhibition by the fact that Mr. T. Garnett, St. John's Gardens, Wakefield, read a paper entitled "Cause and Effect in Chrysanthemum Culture," in which he dealt with the points in dispute which had arisen from his "critique" on Mr. Molyneux's practice, which appeared in the *Journal of Horticulture*. He gave an interesting review of the whole of the controversy which then took place, and said one more year's experience had strengthened him in his opinions as to the correctness of the position he then took up, and he left it to his audience to determine how far their experience coincided with his own. An interesting discussion was opened by Mr. Hemming, who complimented Mr. Garnett on the ability he had displayed in the production of his essay, and in the course of his remarks said that from several years' observation he was of opinion that the dates given by Mr. Molyneux in his book for the propagation of Chrysanthemum cuttings were in many cases too late for the locality in which they resided, and for the majority of varieties intended for large blooms he recommended November-struck cuttings, as giving the best returns. The discussion was continued by Messrs. Featherstone, Daniels (Mirfield), Grix and Wood, the latter of whom spoke highly in favour of the cutting-down system, and said he should continue to practise it. On the motion of Mr. Featherstone, seconded by Mr. Frankland, a hearty vote of thanks was accorded to Mr. Garnett for his admirable paper. Mr. Garnett, having to catch his train, briefly returned thanks, and expressed the hope that the paper and consequent discussion would help to clear up some of the unaccountables.

Time would not allow of the discussion being completed, and the Committee intend devoting a special meeting to that purpose at an early date, and hold out a cordial invitation to all cultivators and lovers of the Chrysanthemum within easy reach of Leeds to give the benefit of their observations and experience. A vast amount of enthusiasm in Chrysanthemum growing is being displayed not only round Leeds but throughout the county of York generally, as is evidenced by the number of exhibitions which have sprung up of late years, and the increased amount of attention given to this popular flower by gardeners. That such will continue may be inferred from the fact that in a prize essay competition on plants grown in pots, for a money prize given by Mr. E. Kay, Holbeck Moor Pottery, Leeds, open to under gardeners in the West Riding, out of the seven papers sent in for competition four were on the Chrysanthemum. The Leeds Paxton Society showed by their

meeting on Saturday that they are determined to keep pace with the times. The attendance numbered over eighty, most of whom were gardeners, and the meeting was ably presided over by Mr. J. Smith (President), with Mr. Frankland (Vice-President) in the vice-chair. Mr. W. Appleby, The Grove, Headingley, Leeds, is the Hon. Secretary.

#### CHRYSANTHEMUM SHOW IN PARIS.

THE recent Show in Paris does not appear to have been very successful from our point of view, as a correspondent states "that the flowers were very small, Pompons the size of buttons, and Mrs. G. Rundle about the size of a medium Pompon Dahlia. Mr. Mease of Liverpool sent a stand of cut blooms, which were by far the finest in the Show." Perhaps if some of our growers were to send a few stands to the continental exhibitions it would assist in the improvement of the cultivation there, and it would certainly increase the number of their admirers. We understand that blooms can be sent without any restriction, but cuttings are not admitted owing to the Phylloxera regulations.

#### JUDGING BY BALLOT.

REFERRING to some remarks on judging Chrysanthemums in our last issue, Mr. H. Cannell sends us a record of the ballot voting by which the prizes he offered were determined at the National Chrysanthemum Show. As the list is prepared we fail to understand the working of the system, and if it were published we suspect the majority of our readers would be at least as much perplexed as instructed. Mr. Cannell observes:—"I was much grieved, not being aware, when distributing the ballot tickets, that the schedule specified the voting was to be confined to members of the Floral Committee; consequently the tickets were handed to various experts. The error having been pointed out it was decided to expunge all votes other than those on the Committee; the decision therefore was left to Messrs. Gibson and Kemp. Mr. Swift was also a member, but unfortunately did not record his vote. It is very gratifying that Messrs. Gibson and Kemp voted in the majority of all four prizes." We should expect Messrs. Gibson and Kemp to vote correctly, and if we understand the list before us Messrs. Molyneux, Shoesmith, Beckett, and Mitchell voted in the same way, and their votes appear to be included in the totals; yet in the final verdict seem to have been struck out for the reason indicated. Still, we are informed, subject to that revision, but through some mistake no prize was accorded to Mr. Martin, though subsequently Mr. Martin was awarded the first prize. The ballot system has not worked well nor given general satisfaction; it is, however, new, and time may be required for perfecting it. Under any circumstances it could only be applicable to a limited number of stands, being much too cumbersome and time-absorbing to be practised throughout a show. It is for committees of societies to determine the manner in which prizes shall be awarded at their shows, and if the Committee of the N.C.S. consider the balloting method the best they will no doubt adopt it in future.

#### CHRYSANTHEMUMS AT PERRY HILL.

MESSRS. J. CARTER & Co. have had an unusually fine display of Chrysanthemums at their Perry Hill Nursery this season, the plants well grown and the blooms fine in all the leading varieties. Two houses were devoted to them, that near the entrance presenting a very bright and beautiful effect, as the plants were arranged to form a long bank in the centre sloping to the door, with smaller banks on each side. Mr. Waters is an experienced Chrysanthemum grower, and it is surprising how so good a display could be provided amidst such a multiplicity of business arrangements. Some of the incurred of the Queen type had deep well proportioned blooms, while the Japanese were extremely good in size and colours. Messrs. Carter's novelty, Bronze Queen, has considerably improved this year, and in several places we have seen handsome blooms of it. Amongst the new Japanese imported by this firm from Japan last season several have proved very promising, the finest up to the present being Mrs. Beale, which was awarded a first-class certificate at the Crystal Palace Show early last month. This magnificent variety has been said to be identical with another also introduced about the same time, but whether that be so or not it is a grand acquisition, the pure white florets being of great breadth and substance, incurving and twisting in a remarkable manner. It is a splendid exhibition variety and will certainly find favour with Chrysanthemum growers.—VISITOR.

#### THE NEWCASTLE-ON-TYNE HORTICULTURAL SOCIETY. ANNUAL MEETING.

ON the 30th ult. the annual meeting of the Durham, Northumberland, and Newcastle-upon-Tyne Botanical and Horticultural Society was held at the Alexandra Hotel, Clayton Street, Newcastle. Ald. Thos. Gray presided, and there was a large attendance. The annual report of the Council was submitted by the Hon. Secretary (Mr. Gillespie). It stated:—

Last year, it will be remembered, closed with the large deficit of £127, and your Council entered upon their duties for the present year with a considerable amount of anxiety as to the future of the Society, not in the least diminished when the results of the spring show became known, which, excellent though it was as a floral display, realised for the two-days admission only the very meagre total of £99 0s. 6d., as against £133 4s. 6d. for the previous year, and £144 12s. for 1885.

In the report for last year allusion was made to certain negotiations, then in progress with the Exhibition authorities, with the view of holding one of the Society's shows in the Exhibition or its adjoining grounds. These negotiations resulted, ultimately, in mutual terms being arranged.

It was determined, after mature consideration, to abandon the summer show for the present year at least, and that an autumn one instead be held in the Exhibition ground on the 31st August and 1st and 2nd September. As the success or otherwise of the Society, financially at least, appeared to your Council to depend so greatly upon the results of this venture, to which they were now fully committed, they at once concentrated their efforts, and spared no expense which they thought would bring in an adequate return, to accomplish the desired result. The main feature aimed at, as an attraction for the autumn show, was to secure an exceptionally large and rare display of fruit, and to this end an unusually liberal prize list was drawn up and widely circulated amongst the most eminent fruit growers in the kingdom. The schedule included a special Jubilee prize, amounting to £50, for exhibits comprising fifty dishes of fruit each; £21 10s. 6d. for fruit, vegetables, and flowers, to be competed for by artisans exclusively, and an additional attraction was afforded by a horse-leaping competition on the last day of the show, for which prizes to the amount of £26 10s. were offered. Fully conscious of their responsibility in publishing a prize list, which, including the horse-leaping competition, amounted to £470, by far the largest ever offered at any one of the Society's shows, and the large expenditure which must necessarily be incurred in connection with a show of the dimension contemplated, your Council appealed by letter to the Executive of the Exhibition for a contribution towards the special Jubilee prize fund, which was generously responded to with a donation of twenty guineas, for which the Council desire to record their grateful acknowledgments. To the numerous other contributors to the special prize fund, who, in order to relieve the strain of the extra expenditure were appealed to by the Secretary, the best thanks of the Council are respectfully tendered. The results of the Show, financially and otherwise, were an unqualified success—the display of fruit, flowers, and plants being of exceptional extent and excellence, whilst the attendance during the three days reached the enormous total of 87,680, an average of more than 29,000 per day, and far exceeding the most sanguine anticipation of all concerned.

As shown by the accounts, the year commenced with a deficit of £126 19s. 9d., and closed with the handsome surplus of £323 9s. 11d. £300 of this amount has been invested with the Newcastle-upon-Tyne Imperial Building Society at 4½ per cent. interest per annum, and the balance of £23 9s. 11d. is in the hands of the Treasurer.

The best thanks of the Council are tendered to Sir Benjamin C. Browne for his occupancy of the presidential chair during the year, and for his donation of £10 10s. to the funds of the Society; to the Vice-President, Mr. George Davidson, Mayor of Gateshead, for his services and donation of £5 5s.; to the Corporation of this city for their renewed contribution of £10; and to the Trustees of the Charles Turner Memorial Fund for their very acceptable donation of £10 to the special prize fund.

During the year, two active and useful members, Mr. W. Dinning and Mr. John Wardle, have retired from the Council, and their places have been filled by Councillor Alex. Hepburn and Mr. Augustus M. Loades respectively.

The Spring Show for next year will be held in Town Hall and Corn Exchange on the 18th and 19th April, and the arrangements for subsequent shows are left to be dealt with by the Council, particulars of which will be duly announced in the public press and by circular.

In closing their report of this most eventful year, the Council desire to express their satisfaction at the greatly improved financial position of the Society, which encourages them to look forward with hope that the future may bring with it a period of long-continued prosperity and increasing popularity and usefulness.

The financial report showed that the total receipts had been £1931 19s. 3d. and the expenditure included last year's deficit, £126 19s. 9d., and this year's outlay, £1481 9s. 6d., the balance remaining being £300 invested, and £23 9s. 11d. in the Treasurer's hands.

The Chairman, in moving the adoption of the report, congratulated the Society on its financial position. Previously, during the last eleven years, the balance had only been once on the right side, that was in 1883, when they had a balance of £57 9s. 7d. In all other years they had been on the wrong side, the deficiency ranging from £13 3s. 7d. to £296 1s. 3d. Gentlemen, however, would bear him out in saying that, during all these years, they had kept up their hearts, and determined to develop the interests of horticulture in that district. The Spring Show had been gradually losing its attractiveness to the outside public during the last two years, and it might be thought that, with the falling off in receipts, it would be desirable to give it up. But they had to bear in mind that that Society had a very large number of members and associates, and it was only fair and due to them that the Council should give them some attractions for their money. The advantage of having members, as against gate money only, was that, whatever the weather might be, they had their fund in hand. Therefore, instead of decreasing their attractions, he thought it would be a wise thing to increase them, so as to insure a larger number of members and associates. With respect to the Summer Show, the deputation that waited on the Exhibition Executive was very courteously received, and a disposition was shown to fall in with their views. The terms agreed on, he believed, had been advantageous equally to the Exhibition and the Society. The numbers attending the Exhibition up to that time had been exceedingly small, and the number for the week previous to the Show was not equal to what they had had on each day. This showed that the Newcastle people not only appreciated the Show, but that people from a distance also did so, for he had the authority of Mr. Smith for saying that never before were the trains with visitors to the Exhibition so well filled as they were in the Show week. They had to thank the Railway Company for contributing, by their arrangements, to the success of the Society. There were complaints by many members, who could not get near the tents nor see the Show on the opening day, and some of them went so far as to threaten to withdraw their subscriptions. He hoped, however, they would see that the Council were not to blame, and would be satisfied. With regard to the future, he thought it would be well, perhaps, if they could establish a Chrysanthemum Show in connection with the Society. This, he believed, would not only tend to keep the members who had taken a little offence at the Autumn Show, but might get them a large increase both in members and subscribers. He was very anxious about that, for at one time they had had about double the number of subscribers they had now. Anything, therefore, that would tend to increase the number of subscribers, he thought, was desirable.

Mr. Benjamin Plummer, jun., seconded the adoption of the report, and added that he thought the Show had been advantageous not only to the Society but to the Exhibition, as they had shown the Exhibition authorities an example in the catering of sports and attractions that had been of great benefit to that institution.

Mr. James Joicey, M.P., Longhurst Hall, was elected President; the Mayor of Newcastle (Mr. W. D. Stephens, J.P.) Vice-President, and seven members were elected to the Council. At the conclusion of the proceedings votes of thanks were passed to Sir B. C. Browne and Mr. Geo. Davidson (Mayor of Gateshead) for officiating as President and Vice-President during the past year, and a vote of thanks was also given to the Chairman.



#### KITCHEN GARDEN.

DECEMBER is not a busy month in the vegetable garden so far as cultivation goes, but it is a time when alterations and improvements should be pushed forward. There are many who almost neglect their kitchen garden from the time the crops cease growing in autumn until it is time to sow again in spring, but we do not approve of this system, as it cannot be followed with advantage, and a garden that is neglected in winter is never forward in spring or the most productive in summer. On the contrary, when all work is done in good season, everything will be ready for sowing and planting in proper time and in a proper manner in spring, and the advantage of this is very great as a rule.

TRENCHING AND DIGGING.—These are two important aids in the production of high-class crops, as in practice we have invariably found that the heaviest crops and finest produce are secured from deep well-tilled soil. There is no exception to this rule, and all with a few spare hours, days, or weeks, in winter, would do well to devote them to trenching or digging. Where the soil is very shallow, and the subsoil is poor or worthless, bringing the bottom to the top would not be beneficial, but if a quantity of old vegetable refuse is trenched down without raising the bad material to the surface, it will improve the subsoil for bringing it up at another time, and if a quantity of soil of any kind can be placed on the surface of shallow land it will assist the crops wonderfully. No one should be satisfied until their vegetable quarters everywhere are at least 2 feet deep, and trenching and adding should be practised every winter until this is secured. Digging may always be done on those parts that have been trenched in recent years, and the surface cannot be left too rough after this operation, as an open surface admits the air and frost, and these always pulverise the soil. Indeed in the case of stiff clay they are almost as good, and certainly as useful as a dressing of manure, and every vacant quarter should be dug at once.

MANURING.—We do not approve of winter manuring, and seldom put any in the soil until immediately before cropping. The land which is dug now does not receive any manure, but a quantity of manure may be wheeled on immediately after digging, and made into a heap to remain there until the spring. This is a much better way of keeping manure than allowing it to lie in some odd corner where its virtues when washed out do not benefit the soil, but run away or sink into some waste ground and are lost. By looking at the spot where the manure heap rested on a vegetable quarter during the winter the extra quality of the produce will always indicate the benefit of this manner of storing it, but this does not apply to refuse, which should always be put under the soil, but only to such material as will benefit the crops immediately after being applied. There is hardly a private kitchen garden in the whole country where the supply of manure can be regarded as ample, and in cases of scarcity the best manure should go to the ground that is intended for the crops requiring most nourishment, such as Onions, Leeks, Cauliflowers, Celery, &c., and the lighter material to Potatoes and other root crops, such as Carrots, Beet, &c.; but apart from this, various mixtures have often to be made up to make the manure go as far as possible, and this is a good time to look to it. Of late many leaves have been collected from pleasure grounds and elsewhere which are not valuable in themselves, but if they are mixed with manure from the cow sheds, pigeries, or stables they will absorb many of the qualities from the rich manure. This is a plan we have to follow ourselves, and it is a good one.

#### FRUIT FORCING.

PINES.—Judgment and considerable skill are required to maintain with limited means a successional supply of ripe Pine Apples throughout the year. The cultivator with his tens or twenties is often at his wit's end how to obtain fruit at the right time, but with hundreds of successions there is no difficulty in maintaining an unbroken supply of fruit. Where a supply of ripe fruit is required in May and June, which is the time when home-grown fruit is most in request and the plants are not showing fruit, it will be desirable to select from those started last March, which have completed a stout growth and are now in a state of rest, such as show the best indications of starting into fruit when subjected to a higher temperature both at the roots and in the atmosphere. If the plants can be accommodated in a structure to themselves it will be an advantage, but failing such they should have a light position in the fruiting house. It is not desirable.



to start more plants at this season than are absolutely necessary, as the fruit will come up more readily a month hence and be much stronger. Continue former instructions as to temperature, &c., but in very severe weather a fall of a few degrees in the temperature is preferable to extra sharp firing, and wherever practicable a covering placed on the glass at such times will be desirable, being a saving of fuel and better for the health of the plants.

**PEACHES AND NECTARINES.—Earliest Forced House.**—With the buds swelling and advancing for flowering the atmosphere must not be kept nearly so close, as it is important that the blossom come on steadily and have time to develop a strong flower, perfect in all its parts. A little ventilation should be given constantly, and above 50° it should be increased correspondingly with the temperature, but not allowing a decline below 50° in the daytime, sufficient artificial heat being employed for that purpose, and with sun heat an advance may be allowed to 65°, closing for the day before the temperature has receded to 55°. A temperature of 40° to 45° is ample at night, or in mild weather 50°. When the blossoms are advanced so that the anthers are showing in the petals cease syringing the trees, but afford a moderate amount of moisture by damping available surfaces, as borders, paths, &c., in the morning and early afternoon. Avoid a moist, close, stagnant atmosphere with a high temperature at night. Make sure that there is no deficiency of moisture in the inside borders. If necessary supply tepid water or liquid manure. Moistening the surface is only waste of time; afford enough to moisten the soil through to the drainage. Weakly blossoms and failures in setting are often a consequence of moisture being given the tops of the trees instead of their roots. If there be a superabundance of blossom remove that on the under or back of the trellis by drawing the hand contrary to the growth. It will materially assist the swelling and strengthen the remaining flowers.

**Second Forced House.**—This may be the first in some establishments. It is that from which fruit is to be gathered in May and early June, and to which fire heat will be applied about the new year. It must be closed at once, fire heat only being used to exclude frost, the trees being sprinkled in the morning and early afternoon, allowing time for them to become fairly dry before night. Nothing is so enfeebling as keeping the trees constantly dripping with moisture, especially at night. Do not allow the temperature to exceed 50° without full ventilation. Soak inside borders with tepid water or liquid manure, and protect those outside with dry leaves or bracken and a little long litter, allowing a slope to the front, so as to throw off cold rains and snow. Some tarpaulin or spare lights would be an advantage.

**Succession Houses.**—Proceed with the pruning, bringing matters in respect of cleansing the house and trees to as speedy a conclusion as practicable. If the houses have fixed roof-lights ventilate to the fullest extent in all but very severe weather. It is much the best plan to remove the roof-lights and expose the trees to the elements for the winter. Even the latest and unheated houses should be treated that way. We find the best results attend that method of procedure. Trees even that are liable to cast their buds, such as Noblesse, retain them, and attain to a much finer development of flowers than attends trees that are kept constantly evaporating from the young wood through the time they are at rest by fixed roofs. The fogs, drizzling rains, and damp of November and December, with the drenching rains and snow, seem to suit Peaches, the trees being invigorated and the soil enriched.

#### PLANT HOUSES.

**Tree Carnations.**—The earliest of these plants that have flower buds in a prominent condition should have a light position where the temperature at night will not fall below 50°. Under this treatment they will continue to develop their flowers. A circulation of air should be maintained daily when the weather is favourable to prevent the plants being drawn up weakly. Later plants, or those for spring flowering, must also occupy a light airy position with a temperature 5° to 10° lower. Allow the plants to stand upon some moist base, and water them carefully. A little artificial manure may be applied to the surface of the soil of all that have the pots full of roots. Watch for aphides, which are very liable to make their appearance at this season of the year, and are readily destroyed by fumigating them with tobacco. Such varieties as Souvenir de la Malmaison, Gloire de Nancy, and others of a similar nature required for later flowering should be kept cool.

**Hydrangea paniculata grandiflora.**—Plants that are established in pots may be pruned close back, leaving only one joint of the current season's wood. The surface soil may be removed and the plants top-dressed with loam and one-third of decayed manure. If any of the pots are small in comparison to the size of the plants, transfer them into pots a size larger. For this purpose use good loam, a little sand, and one-seventh of manure. The soil should be pressed firmly into the pots, which should then be plunged in cold frames until it is necessary to start them into growth.

**Hydrangea hortensis.**—Where this and its varieties are grown in quantity for conservatory and other forms of decoration, they should now be dwarf, sturdy, and well ripened in 2½-inch pots. Those required for early flowering—in fact the whole stock, may be transferred to 4 and 5-inch pots in which they are intended to flower. This operation is frequently deferred until they start into growth or show their flowers. At that season of the year many things require immediate attention, and work that can be done now should not be delayed. We have always found them flower and do equally as well when potted during autumn or winter as they have when the work has been done some months later. If the plants have been properly treated none of them should exceed

3 inches in height. The stem in potting can be considerably reduced by placing them as low in the pots as possible. One good crock at the base will be ample. The soil should be the same as advised for *H. paniculata*, and pressed firmly into the pots. This is important, and will prevent their running up more than 9 inches or 1 foot in height when the heads are fully expanded, provided they are treated right in other respects. After potting, plunge the pots amongst ashes in cold frames until they have enjoyed a good rest, when those for early flowering may be started close to the glass in ainery or Peach house.

**Roses.**—Hybrid Perpetuals required for early flowering may now be pruned back closely, and placed in vineries, Peach houses, or any cool structures for a few weeks until growth commences, when they may be assisted by gentle heat. Avoid the use of too much fire heat, or they will lengthen out weakly, and their flowers will be small and poor. The temperature should not exceed 55° at night, and this only on mild occasions. The remainder of the stock may be lifted from the plunging material outside and placed in cold frames. Tea varieties in pots that have been standing in cool houses for the last month will be showing signs of growing. Introduce these into a temperature of 50°, and they will commence flowering freely by Christmas.

#### THE FLOWER GARDEN AND PLEASURE GROUND.

**Lily of the Valley.**—No border flowers better repay for good cultivation than these. Left crowded for many years in narrow borders they naturally flower very indifferently, both as regards the quality and quantity of the spikes. Some people imagine they have an inferior variety, but if they went the right way to work they would soon find theirs would equal the best imported clumps or crowns. They are of very accommodating habit, and will bear replanting at almost any time. We prefer to do it at this rather slack time of year. A good length of bed is forked over and the crowns divided, the plumpest and best being principally laid on one side for forcing and flowering in pots, pans, or boxes. Those replanted are spread out thinly on well prepared ground, usually in a cool part of the kitchen garden, and covered with about 2 inches of good soil. This lifting and replanting does not interfere with the flowering, and the new beds are fit for lifting again in about three seasons. Both new and old beds may with advantage receive a mulching of old Mushroom bed refuse or leaf soil at the present time.

**Herbaceous Borders.**—These being duly cleaned, but not dug—this being better or more safely done after the bulbs are more through the ground—the next thing to be done is affording some kind of protection to the more delicate species. Delphiniums, Phloxes, Potentillas, Spiræas, Japanese Anemones, Pyrethrums, Tradescantias, Achilleas, and Asters are with us quite hardy, but even these are benefited by a mulching of leaf soil, ashes, spent tan, cocoa-nut fibre, or strawy manure, and many other species absolutely require it. It should be mounded up well round the plants, but not so as to smother any leafy growth there may be. Choice Hollyhocks, border Chrysanthemums, and Pyrethrums are liable to be cleared off by slugs, and it is the wisest plan to pot a portion or all of these plants, wintering them in cold frames.

## THE BEE-KEEPER.

### PRACTICAL BEE-KEEPING.—No. 24.

PAST care ensures future success. If a large surplus of either honey in the comb or extracted is desired too much attention can hardly be given to the winter preparation of those stocks which are expected to yield the harvest. With more care and attention bestowed on stocks in early autumn less would be heard of bad years, and in very many instances a large increase in the average weight of honey taken would be gained. It is not necessary to "coddle" bees in the cold months of the year, but it is most essential to keep them as dry as possible; to give them sufficient ventilation without draught, to leave them a good supply of food, and to see that every stock has sufficient bees to insure not only that it will live through the winter, but that in spring it will be strong, ready for the harvest, enough to work in supers or give a large swarm early in May without extraordinary care and preparation being bestowed upon it. Strong stocks kept dry will winter under otherwise most unfavourable conditions, but even the strongest stock will often entirely succumb, or at least receive grievous damage, if there is a hole in the roof through which the damp can percolate. The one great essential to success in wintering is a covering which, while admitting a free circulation of air above



the hive, will effectually prevent rain or snow from finding an entrance. An ordinary wooden roof very often cracks after a dry hot summer, and if care is not taken to remedy the mischief before the storms of rain and snow come on an injury may at once be done, and unless immediate precautions are taken the ruin of the stock will be inevitable. A little putty worked into such crevices and fissures and a good thick coat of paint over the whole roof will defy both rain and snow, and keep the hive dry and free from injury through the longest winter.

Attention is very often not paid to covering the frames of the hive itself. In some cases there is barely any covering at all, and in others there is more than enough for three or four hives on every stock. A porous covering is so good and useful that it seems unnecessary to advise anyone to try the American cloth which is now used extensively in some apiaries as a winter covering, and with apparent success. Hives cannot have a better covering for winter purposes than one consisting of calico next the frames, then several pieces of felting, and on the top of these a section crate filled with sawdust or corkdust, and of sufficient size to extend over the surface of all the frames. There will, when such a covering is used, always be an upward though hardly perceptible ventilation, and both bees and comb will in spring be found in excellent condition, provided that sufficient care is taken in other respects. Above the section crates so filled, and between it and the roof of the hive, there should be a space of at least 6 inches. Under the eaves of the roof there should also be two or more small holes covered with perforated zinc, and so placed that the wind cannot drive the rain or snow into the hive. By means of these holes there will be a continued circulation of the air above the section rack, and any moisture which may by chance accumulate within will soon be dried up, and any moisture which may percolate through the top coverings of the frames will at once be carried away. With such a winter covering the entrance to the hive need not be large, although on the other hand if the bee-keeper is able to prevent mice from entering and gnawing the combs there is no objection to having an entrance larger than those usually seen in the winter months. Care must also be taken that the stand of the hive is firm and able to resist the strong winds which are sure to beat upon it with great force before another spring. If the hive is on a stand consisting of floorboard and legs, then pieces of slate or other material of a similar nature should be placed beneath each leg to assist in preserving it against the insidious onslaught of damp, which will cause the wood to rot, and may be the means, unless the mischief is perceived in time, of causing trouble and loss. Every roof must be made firm by some means or other to the hive which it protects. It is very easy to devise a fastening which shall unite roof and hive together securely, but if no other means are available a couple of bricks tied one on each end of a string of suitable length and slung over the roof of the hive and allowed to depend on either side will be a sufficient safeguard, even if in appearance a somewhat clumsy and awkward looking device.

A good supply of food is an absolute essential to a successful winter management. A short supply, and consequently threatened starvation, causes restlessness and the loss, owing to flights on unsuitable days, of many bees. At least 25 lbs. of honey should be left, or an equal amount of syrup stored, in every stock. It is poor economy to starve bees in January and February when they are just beginning to become more valuable than at any other time of the year. If it pays to give 15 lbs. of

honey to support a stock until the end of January, surely it is also profitable to allow another 10 lbs. to assist the bees to tide over the spring months also. To give an insufficient supply of food is utter folly and waste, but to allow bees to consume a quantity of food and then to die is absolute and irreparable loss without one single or possible advantage; yet this is a course only too often pursued in certain apiaries where confusion exists as to the difference between an economical and a miserly management. Economy should by all means be practised, but care must be taken that the desire to practise economy does not become a craze for saving pennies at the expense of pounds.

Weak stocks are very rarely profitable when managed upon the lines generally followed in apiaries of considerable size. It is possible, no doubt, to build up a few bees into a strong colony capable of yielding a considerable surplus, but it is more than questionable whether it is in any way profitable to keep over the winter (except for experimental purposes or for preserving a few spare queens to supply the place of those which may possibly die in the course of the winter) such small colonies. It is, in general at any rate, a far wiser policy to winter two or more small lots together in autumn, and thus to form one good colony which will not require extra labour or extra care in the early and busy months of spring, than to keep them separate. Some bee-keepers believe, and act upon their belief, that bees winter better when confined to a space which they are well able to fill rather than when they are allowed to occupy the whole of the hive. Bees may winter well in hives thus reduced in size, but judging from experience extending over many years it seems almost preposterous for any bee-keeper to attempt to maintain that a stock will winter better in a reduced hive than in one allowed to remain at its full size. Colonies under such circumstances may winter well, but they cannot possibly winter better than do those stocks which are allowed to remain undisturbed in hives of a large size, which allow several combs unoccupied by bees to hang on either side. The best stocks in spring are those which have neither had any frames taken away or any excessive care taken to keep them warm. Those who winter a few seams of bees on three or four frames may possibly have an advantage in reducing their hives to a capacity which will barely hold the bees, but the owner of a strong stock will make a great mistake if he thinks that by crowding his bees on to a reduced number of frames he is furthering his own interests; and if for the sake of comparison he will treat two stocks as far as possible identical with regard to the age of queen, number of bees and food supply, one on the one plan, the other on the other, he will quite probably be surprised to find that the unreduced hive will in March and April contain the greater number of bees, and that it has not in any way suffered, while the reduced hive will have had a marked increase of mortality, and will consequently be weaker than its rival. —FELIX.

## NOTES ON BEES.

### BEES WEARING OUT AT THE HEATHER.

AT page 459 "A Hallamshire Bee-keeper" says, "I have several times noticed 'A Lanarkshire Bee-keeper' assert that working on the Heather seems to wear bees to death more than any other honey-yielding blossom. It seems to be well understood by those who are in the habit of taking their bees to the Heather, and he has also several times asserted that no satisfactory explanation has been given. If he will carefully ponder over these lines I think he will now comprehend the cause." Has "A Hallamshire Bee-keeper" not made a mistake in attributing to me the above

words? Will he kindly point out the numbers and pages which he quotes from? I do not remember using such expressions, nor should I do so, because they are contrary to facts. If the words were used they would be qualified, and the cause or manner of death given. I therefore repudiate the charge until it is shown where the quotation was taken from. I have witnessed hives at the moors having nearly all their bees lost, but not by working on the Heather, but by some occult influence of Heather or season which I cannot explain.

#### THE DISTANCE BEES FLY.

The cogitations of "A Hallamshire Bee-keeper" are interesting, but I do not agree with him in all he says. I am in possession of a number of letters bearing upon the discussion of how far bees fly to the Heather, but only one of these letters state any experiment. The author of this information says, "I have placed bees in the midst of the Heather, and at one mile and one and a half mile distance from it. Those placed in the midst of it gathered less than those beyond it." The cause of this is not given, but my own opinion is widely different from that given by "A Hallamshire Bee-keeper." It is a fact that flowers do not always present their gift of honey at all hours of the day, neither does the same kind of flower always withdraw the gift at the same time. Frequently we find bees working on a patch of Heather in the morning that is deserted by them at noon, or we see them there at noon, and they desert it at four o'clock. The time Heather yields most honey is the last week of its bloom. So plentiful is the honey at this time that when walking only a very few yards the shoes become clotted with it, and at this time, although raining (if calm) the bees gather great quantities of honey, and although scores of bees were gathering from but a few yards, they would scarcely be seen, never having to do more than creep from spray to spray. Thunder showers and sudden cold gusts of wind are fatal to bee life on the moors, and the farther bees have to fly beyond a half mile or so, the more loss of bee life there is.

The reason bees do not gather so much honey when situated right in the midst of the Heather as those situated a mile or so from it, is simply because the bees working near their hives may be working all day long on Heather the honey of which has either been all extracted by the bees early in the day, or the flowers have ceased to yield it in quantity sufficient for the bees to store. Finding a spot agreeable to their wants in the morning, the supply is greatly diminished by midday, although never wholly exhausted, sufficient charms being left to allure the bee, but to spend its time, if not in idleness, in vain search. Now when bees are situated at a little distance from the Heather they do not confine themselves, working upon a spot exhausted, or partially so, but acting upon instinct and great power of smell, fly direct to the spots yielding the most honey, and I have witnessed bees working upon a different spot several times a day. Although I am perfectly cognisant of the fact that bees fly four or five miles to the Heather, to place them that distance from it, expecting them to make great weight, would be folly.

#### BEES RESWALLOWING HONEY.

I beg also to dissent from the idea that bees must necessarily reswallow their honey before it is honey proper. "Ripening honey" sounds harsh, and the modern mode of "ripening honey" is to me absurd. I do not deny the fact that when bees have empty cells below, but that they fill them through the day, then by degrees, not at night wholly, but at the times most suitable for themselves, which may be a wet day or two, if the temperature is high enough, gather the honey to the highest cells that are empty. Should the temperature be low the bees will never move it until it is to be consumed by them.

There is one thing to be borne in mind—viz., bees never mix two sorts of honey, keeping every kind in cells distinct by itself. Now I am in the habit of taking my bees to the moors (when the season admits) for the purpose of getting supers filled with honey from the Thyme. For this purpose I take care that the hives have no empty combs beneath, and in a state ready for the bees to build in the supers. Two years ago I was fortunate in getting a large quantity of this delicious honey, and I am certain not a cell of it was stored below, neither was it reswallowed by the bees, but was at once stored in the supers, which the bees commenced to on a Saturday, and had them sealed in about five days, each cover weighing about 30 lbs. There was no time to lose in reswallowing. The great heat raised by the bees on these occasions is not so much to expel water, as it is to enable them to secrete wax, serving both purposes perhaps. It is the law of gravity that enables the bees to separate the water from the honey. Owing to the inclination of the cell and the water being lighter than the honey rising towards the top, the bees gradually sip it off until the cell is thoroughly sealed, and then the bees discharge the superfluous moisture when on the wing or through perspiration. It is also a fact that although

honey is thoroughly freed from superfluous moisture if allowed to stand exposed, it draws moisture again from the atmosphere, rendering it deficient in quality and perhaps favourable to start incipient foul brood. Hence the reason why I object to extracting unsealed honey, then put it through a "ripening" process. Honey proper cannot be improved by any process known as clarifying or ripening, nor by any admixture whatever.

I could adduce hundreds of cases in support of my statements, but I will allow the following to suffice. A hive swarmed at the moors this year. The bees were at first put into a hamper, but afterwards into a straw skep, but not for a day or two. At the time the bees were put into the hive a super was put on. The weather was fine and the bees started work in earnest, first in the super, making combs and storing honey in it before there was a single cell built in the hive. At the end of four days the super was sealed, and at the end of four more days another was finished. There not being combs in the hive to store honey, why did the bees, or why could they, store honey and seal it in the supers as stated above, if it was necessary that honey should be reswallowed before it is honey proper? Perhaps someone will answer. If not, it must be considered, as it was in Mr. Pettigrew's case, that the theory is untenable. Mr. Pettigrew had nothing but straw hives to deduce and base an argument on further than theory; but all the same, his large straw hives were admirably adapted to have empty cells beneath, and naturally the bees in a glut store there, seal by degrees, but it ends there.

#### BEES GATHERING HONEY FROM LOW LYING GROUND.

It is also a mistake to say that bees do not gather honey from low lying Heather. Heather, as a rule, growing upon moss does not yield much honey unless in warm seasons. Yet the Lohar moss, almost on sea level in Dumfriesshire, yields much honey of fine quality. Still, I observe that honey gathered at a high altitude is often of superior quality than that gathered lower down. The quality of honey depends greatly upon the kind of rock or soil beneath the surface. Bees when situated near the Heather will return from a distance to their hives filled with honey or laden with pollen in ten minutes from the time they left, and when plentiful in a shorter time.

I did not require to give any evidence whether bees "situated in the midst of the Heather" had to fly three or four miles for honey, because the Heather was about four miles square, and beyond that there was none unless the sea was crossed on one side and many miles of land on the other. I shall be glad to hear further evidence on these interesting points.—A LANARKSHIRE BEE-KEEPER.

#### TRADE CATALOGUES RECEIVED.

H & F. Sharpe, Wisbech.—*Catalogues of Specialties and Seed Potatoes.*  
Wm. Fell & Co., Hexham.—*Catalogue of Forest Trees, Ornamental Trees, and Shrubs.*  
John Laing & Sons, Forest Hill, London.—*Special List of Chrysanthemums.*  
Thomas Laxton, Bedford.—*List of Novelties and Specialties.*



•• All correspondence should be directed either to "THE EDITOR" or to "THE PUBLISHER." Letters addressed to Dr. Hogg or members of the staff often remain unopened unavoidably. We request that no one will write privately to any of our correspondents, as doing so subjects them to unjustifiable trouble and expense.

Correspondents should not mix up on the same sheet questions relating to Gardening and those on Bee subjects, and should never send more than two or three questions at once. All articles intended for insertion should be written on one side of the paper only. We cannot reply to questions through the post, and we do not undertake to return rejected communications.

**Chrysanthemum Album Plenum (W. N. M.).**—The above is the name of the variety of which you have sent blooms, which are very good, and you appear to have grown the plants well. They must have been misnamed before coming under your charge.

**Cyclamen Flowers Deformed (F. J.).**—The flowers will sometimes come deformed like those you sent if the plants are unusually vigorous, and they

are checked when developing by too low a temperature or too dry an atmosphere. Occasionally, also, too liberal supplies of liquid manure or too much manure in the soil will cause similar distortion.

**Affiliating Societies to the National Chrysanthemum Society (R. H. T., Pembroke).**—You can obtain particulars of the conditions upon which provincial societies are affiliated to the above on application to Mr. Wm. Holmes, Frampton Park Nursery, Hackney. Medals are issued at cost price and two certificate cards free to each society, they also each have the privilege of electing a member of the General Committee.

**Fruiting Vines (Dumfries).**—As you lived with the gentleman to whom you refer when the work was accomplished, you ought to be able to name the exact year, and if you will do this we will endeavour to find the record, which we presume is what you require, though you fail to make your wishes clear to us. If we find one record, that will probably guide us to the other. Please write again, stating what you wish us to do, and if you give us the date of the year for reference we will oblige you if possible.

**Reporting Chrysanthemum Shows (A. E.).**—It is certainly our desire to report all the shows practicable, and when tickets are received or the shows advertised in our columns we endeavour, though in every case we may not succeed, to obtain an account of the show for publication. We are much indebted to local gardeners and competent amateurs for reports of shows that we should not otherwise receive, and we thank them for their co-operation. The tickets to which you refer, we regret, did not reach us, nor was your show advertised in this Journal.

**Nerines and Amaryllises (W. H. K.).**—You have treated both plants in opposition to their requirements, and it is not surprising that they are unsatisfactory; under ordinary circumstances the Nerines would have just flowered and be making their growth. The growth of the Amaryllises should be made during the summer and early autumn months, then be rested. The best plan will be to repot the latter early in January in a compost of loam and one-third leaf soil, with a little old manure and sand. The Nerines can be treated similarly a month or two later, employing more sand in the soil. The Orchid is *Brassavola nodosa*. The Ferns we could not distinguish, as no numbers were attached to them.

**Roses to Cover Trees and Wire Arches (Rosa).**—For the trees, which we presume have not much head, consequently the soil not dried and impoverished by their roots, Roses of the Ayrshire class—viz., Dundee Rambler, white, tinged with pink; Queen of the Belgians, white; and Ruga, pale flesh, would suit; also of Boursalt Amadis, purplish crimson; of Multiflora Rubra, red; but the best climbing Rose of the desired colour—viz., pink, is Setina, an American variety, with beautiful silvery pink flowers. For the wire arches have Tea-scented Gloire de Dijon, Reine Marie Henriette, red; and Waltham Climbers, No. 1, 2, and 3, all red. To those add Bouquet d'Or and William Allen Richardson, both Noisette. Any Rose-growing nurseryman will be able to supply them.

**Grubs in Soil (Amateurs).**—The examples sent are the larvæ of the very destructive weevil, *Otiorhynchus tenebrius*, the habits of which are described on page 372, October 27th, 1887, in reply to a correspondent who sent Cyclamens that had their roots eaten exactly in the same way as in the corm you have sent. He was advised to scorch all soil before using it for potting purposes, sufficiently to destroy insect life. This we also advise you to do, moistening the soil sufficiently for compression before using. Our correspondent now adopts that plan, and he has also informed us that Lemon oil applied to soil in which plants are established has been of great benefit in exterminating their enemies. It can be had from many nurserymen, seedsmen, and dealers in garden requisites, with instructions for use.

**Excrescences on Peach Tree Roots (Caterham).**—The knots on the roots sent are common to Peaches, Nectarines, and Plums, also to Apricots, all of which are on Plum stocks. They are most prevalent when the soil is loose, and of a light or vegetable nature. When the roots get into the condition your trees exhibit it is a clear indication that there is a want of reciprocal action between the roots and branches, which may be a consequence of the stock not enlarging with the scion, or the imperfect transmission of sap through the faulty junction. We have usually found that lifting the trees is useful, and an addition of soil of a heavier nature is most beneficial. From the excrescences in due course would appear suckers. If it be necessary to remove them it should be quite down to whence they originate, so as to prevent their reappearance.

**Chrysanthemums (Cambridge).**—You will observe what is said about Amy Furze in another column. We have seen blooms suitable for reflexed stands, and others that could not be so regarded. It appears to vary with age and when strongly grown, then displaying what it undoubtedly possesses—a good deal of the Japanese character. Avalanche, as grown and exhibited by Mr. E. Molyneux, is a true Japanese—large, distinct, and effective. Agnes Flight, as we have seen it, is rather small, but so were Edwin Molyneux and Mrs. J. Wright last year; but this year blooms have been produced large enough for any stand, therefore we think Agnes Flight worth trying. As Anemone varieties are rather scarce you may add Annie Lowe to your collection, also a variety you do not name—Thorpe Junior, as if you produce blooms of it equal to some we observed at Chilwell they will be worthy of a place in the best stands, but a few irregular ray florets may require to be withdrawn, so that those remaining are of equal length.

**Roses for Exhibition (W. C.).**—Bourbon Roses are of little or no use for exhibition, but occasionally a bloom of Souvenir de la Malmaison may be seen in prize stands. Nor can you expect to exhibit except in the smallest classes, from twenty-four plants of Hybrid Perpetuals, and six of Teas and Noisettes. It is a popular fallacy to suppose that a person can show as many good blooms on a given day as he has plants for producing them. The best of cultivators with the best of soil cannot rely on one-fourth. You may, however, only desire to show in the smaller classes, or, if otherwise, perhaps intend to order duplicate plants. The following are good exhibition varieties, and ought to succeed in your district with good cultural attention. Hybrid Perpetuals:—Madame Gabriel Luizet, Ulrich Brunner, A. K. Williams, Merveille de Lyon, Marie Rady, François Michelon, Marie Banmann, La France, Marie Cointet, Marquise de Castellane, Duchesse de Vallombrosa, Baroness Rothschild, Etienne Levet, Monsieur Noman, Alfred Colomb, Louis Van Houtte, Abel Carrière, Charles Lefebvre, Le Havre, Beauty of Waltham, Prince Arthur, Marie Verdier, Star of Waltham,

Comtesse d'Oxford. Teas:—Catherine Mermet, Comtesse de Nadaillac, Innocente Pirola, Souvenir d'Elise Vardon, and Souvenir d'un Ami.

**Potts' Seedling Apple (J. Adams).**—Your tree is probably correctly named, though the fruits as you say "are not exactly what they should be." The dry summer has probably affected them. We give an outline of a fruit and a few particulars respecting the variety. According to Mr. Petch, the experienced representative of Messrs. Richard Smith & Co., of Worcester, this Lancashire Apple possesses a property that entitles it to the consideration of those who have gardens in smoky districts. "There is no Apple in existence," Mr. Petch says, "that will grow so well in and near large towns as Potts' Seedling, and it should be recommended particularly for that purpose." As confirmatory of the accuracy of this estimate we have seen fine crops of splendid fruit in Mr. Firth's garden at Riverdale, Sheffield. Mr. Abbott, who was then the gardener there, regarded it as the most useful Apple in the collection, and wished that half of the entire number of trees were of this variety. Many of the Sheffield-grown fruits were much larger than that represented, which is submitted as a fair average specimen. The fruit of this Apple emits a powerful scent of ether or chloroform. It is very irregular in outline, roundish and flattened, very angular on the sides and at the base, also puckered and ribbed round the eye. Skin smooth, shining, and unctuous when ripe, of a uniform greenish straw colour, and

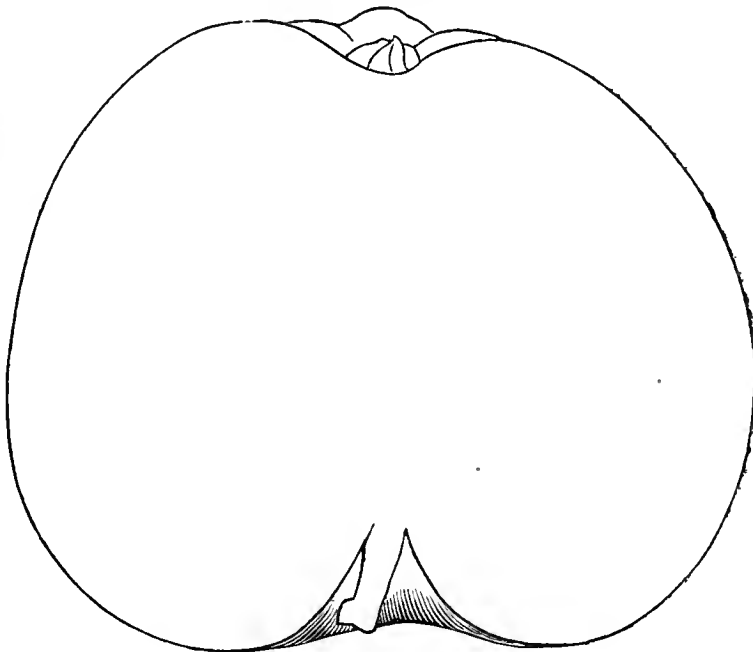

Fig. 6.—Potts' Seedling.

sprinkled with russet dots. Eye large and closed, set in an angular and ribbed basin; tube wide, conical; stamens marginal. Stalk half an inch long, stout, inserted the whole of its length in a deep cavity. Flesh very tender and pleasantly subacid with all the character of the flesh of Codlins. Cells of the core open; cell-walls elliptic, obovate, with toothed fungoid veins. An early Apple, ripe during September, of the Lord Suffield and Domino class, but heavier and keeps longer, often remaining firm until November. The tree is a good grower, with large roundish leaves like the Hawthornden, and bears freely. Mr. Nelson of Catcliffe, near Rotherham, found this Apple about thirty years ago in the garden of a Gooseberry grower at Oldham, who, he stated, had procured his trees from a Mr. Potts, who had raised it.

**The Origin of the Green Gage Plum (J. Jackson).**—You are probably incorrect. As we have before stated in this Journal, and as is published in the "Fruit Manual," this universally known and highly esteemed fruit has been longer in this country than is generally supposed. It is said to have been introduced at the beginning of the last century by Sir Thomas Gage, of Hengrave Hall, near Bury St. Edmunds, who secured it from his brother, the Rev. John Gage, a Roman Catholic priest then resident in Paris. In course of time it became known as the Green Gage Plum. In France, although it has many names, that by which it is best known is Grosse Reine Claude, to distinguish it from a smaller and much inferior Plum called Reine Claude Petite. The Green Gage is supposed to be a native of Greece, and to have been introduced at an early period into Italy, where it is called Verdochia. From Italy it passed into France, during the reign of Francis I., and was named in honour of his consort Queen Claude; but it does not appear to have been much known or extensively cultivated for a considerable period subsequent to this, for neither Champier, Olivier de Serres, Vautier, nor any of the early French writers on husbandry and gardening, seem to have been acquainted with it. Probably, about the same time that it was introduced into France, or shortly afterwards, it found its way into England, where it became more rapidly known, and the name under which it was received was not the new appellation which it obtained in France, but its original Italian name of Verdochia, from which we may infer that it was brought direct from Italy. It is mentioned by Parkinson, in 1629, under the name of Verdoch, and, from the way he speaks of it, seems to have been not at all new, nor even rare. It is also enumerated by Leonard Meager, in the "list of fruit which I had of my very loving friend, Captain Gurlie, dwelling at the Great Nursery between Spitalfields and Whitechappel," and is there called Verdochia. Even so late as the middle of the last century, after it had been re-introduced, and extensively grown under the name of Green Gage, it continued to bear its original title, and to be regarded as a distinct sort from the Green Gage. Hitt tries to describe the distinction; but as he tries also to show that the Reine Claude is also dis-



distinct from the Green Gage, his authority cannot be taken for more than it is worth; a remark which may safely be applied to all our pomologists of the last century. Miller also laboured under the same misapprehension as Hitt, for in his Dictionary he says, speaking of the Grosse Reine Claude, "this Plum is confounded by most people in England by the name of Green Gage." We have seen, therefore, that the generally received opinion that this valuable Plum was first introduced to this country by the Gage family is incorrect, but that it must have existed for considerably upwards of a century, at least, before the period which is generally given as the date of its introduction.

**Making Rockwork (Benton).**—Almost every rockery demands special treatment. There are, moreover, two distinct methods of procedure according to the effect that may be desired. If the body of the rock is intended to be raised much above the ground level, a quantity of soil and rubbish should be carried into the centre of the space. This soil, besides serving to support the rockwork, will also form a border for the plants to grow in. Having at hand plenty of large rough stones, broken bricks, or stony rubbish of any kind or colour, proceed with these to imitate the form of natural rock as nearly as possible. Rough, bold, angular projections, and deeply formed chasms are the principal features in natural scenery which please us most. A rock, with a flat unbroken surface, whether horizontal or perpendicular, presents too much sameness to be pleasing to the eye; therefore, in imitating Nature, the projections should be varied and bold, and unless raggedness and intricacy form principal features in its composition it will lose much of its effect. If the rockwork be on a large scale it should not be one continued line, but broken at intervals, in one part lost beneath the surface of the earth, and again rising in another part and resuming its sinuous form. So far there is little difference between this and the common method of making artificial rock. When, however, every stone has been arranged to suit the eye, the interstices between them are to be filled up with any kind of rough mortar. Of course, fissures and similar places intended for the plants which are to cover the rock must be left open, so that the roots may penetrate to the soil beneath the stones. The next operation is to damp the whole mass over with Roman cement. For this purpose the latter should be mixed with water until it is of the consistency of thick paint, in which state it may be applied to the stones with a large painter's brush. The spaces between the stones having been filled with rough mortar prevents the cement from being wasted. The thickness of the latter on the stones need not be more than the eighth of an inch. It will unite the whole into one mass, and the rockwork thus constructed is, beyond all comparison, far more natural than that made in the usual way. It has none of that disjointed appearance which usually accompanies rockwork made without cement. After a few months' exposure to the weather rockwork thus formed (if skilfully made) cannot, without careful examination, be distinguished from a natural mass; it will soon cover all but the most prominent parts. If the cement be of a colour too light, which for some situations may be the case, a little lampblack or soot may be mixed with it. Care must, however, be taken that no substance which may make the cement more porous is used, otherwise it will peel from the stones after a hard frost. For the benefit of those who are not accustomed to using cement we may mention that no more should be moistened at once than can be used in a short time. If the cement be good it will quickly harden, and will then be in a manner useless. In making artificial rock for waterfalls, or other constructions, where the cement may be constantly exposed to the action of the water, the best water-cement should be used. Any preparation that does not quickly indurate under water will in a short time be washed away, and leave nothing but the bare stones.

**Names of Fruits.**—The names and addresses of senders of fruit to be named must in all cases be enclosed with the specimens, whether letters referring to the fruit are sent by post or not. The names are not necessarily required for publication, initials sufficing for that. Only six specimens can be named at once, and any beyond that number cannot be preserved. (G. S.)—Beurré Diel. (J. J. S.)—1, Napoléon; 2, Durondeau; 3, Duchesse d'Angoulême; 5, Beurré Superfin; 6, Bergamotte Esperen. (William Seaton).—1, Flanders Pippin; 2, Beauty of Kent; 3, Local; 4, Local; 5, Scarlet Nonpareil; 6, Golden Pearmain. (M. H.)—1, Deux Sœurs; 2, Josephine de Malines; 3, Beurré Capiaumont; 4, Deux Sœurs; 5, Knight's Monarch. The Apple is London Pippin. We could not find a pill box of which you write. (W. H. J.)—1, Hawthornden; 2, Scarlet Nonpareil; 3, Beurré Diel; 4, Margil; 5, Quite rotten; 6, Warner's King. (A. L.)—1, Durondeau; 2, Elton; 3, Not known; 4, Cox's Orange Pippin. (Courtenay Lord).—French Codlin. (J. Mooreby).—1, Rhode Island Greening; 2, Van Mons Leon Leclerc; 3, Golden Winter Pearmain; 4, Beurré Rance; 5, Sturmer Pippin; 6, Beurré Diel. (H. E. Monk).—1, Lewis' Incomparable; 2, Not known; 3, Braddick's Nonpareil; 4, Aromatic Russet; 5, A Cider Apple not known; 6, Ross Nonpareil. (J. R. Pearson & Sons).—Undoubtedly Cox's Orange Pippin. (Agnes Pain).—1, Yorkshire Greening; 2, Ord's Apple; 3, Trumpington; 5, Lane's Prince Albert; 6, King of the Pippins; 7, Beachamwell. (H. Heath).—1, Van Mons Léon Leclerc; 2, Baronne de Mello; 3, Figue de Naples; 4, Knight's Monarch. (A. Haggart).—The two small Apples are Blenheim. The large ones are very fine specimens of the same variety. Soil and situation have great influence on the coloration of fruits as well as on their development, and the Blenheim Pippin is one of the varieties easily influenced. There have been many instances where the Blenheim has given rise to new names from this circumstance. (Andrew Blackie).—1, Mère de Ménage; 2, Lane's Prince Albert; 3, not known.

**Names of Plants.**—We only undertake to name species of plants, not varieties that have originated from seed and termed florists' flowers. Flowering specimens are necessary of flowering plants, and Fern fronds should bear spores. Specimens should arrive in a fresh state in firm boxes. Slightly damp moss or soft green leaves form the best packing, dry cotton wool the worst. Not more than six specimens can be named at once. (Inquirer).—1, Davallia Mooreana; 2, Davallia parvula; 3, Gleichenia Mendeli; 4, Todea pellucida; 5, Trichomanes reniforme. (R. S., Ipswich).—1, Impatiens Hawkeri; 2, Impatiens Sultani; 3, Apparently a portion of a leaf of Dracæna Lindenii; 4, Sophronitis grandiflora, a good variety. (Amateur).—1, Odontoglossum Rossi majus; 2, Liparis pendula; 3, Lælia autumnalis. (Victor).—We should think your plant is Griffinia Blumenavia.

COVENT GARDEN MARKET.—DECEMBER 7TH.

No alteration. Business still stagnant.

PLANTS IN POTS.

	s.	d.	s.	d.		s.	d.	s.	d.
Aralia Sieboldi, dozen ..	6	0	12	0	Fuchsia, dozen ..	0	0	to	0
Arbor vitæ (golden) dozen ..	6	0	9	0	Geranium (Ivy), dozen ..	0	0	0	0
" (common), dozen ..	0	0	0	0	" Tricolor, dozen ..	0	0	0	0
Asters, dozen pots ..	0	0	0	0	Hydrangea, dozen ..	0	0	0	0
Azalea, dozen ..	0	0	0	0	Lilies Valley, dozen ..	0	0	0	0
Begonias, dozen ..	4	0	9	0	Lilium lancifolium, doz.	0	0	0	0
Capsicums, dozen ..	0	0	0	0	" longiflorum, doz.	0	0	0	0
Chrysanthemums, dozen ..	4	0	13	0	Marguerite Daisy, dozen	6	0	13	0
Cineraria, dozen ..	0	0	0	0	Mignonette, dozen ..	0	0	0	0
Dracæna terminalis, doz.	30	0	60	0	Musk, dozen ..	0	0	0	0
" viridis, dozen ..	12	0	24	0	Myrtles, dozen ..	6	0	12	0
Erica, various, dozen ..	9	0	18	0	Palms, in var., each ..	2	6	21	0
Euonymus, in var., dozen	6	0	18	0	Pelargoniums, dozen ..	0	0	0	0
Evergreens, in var., dozen	6	0	24	0	" scarlet, doz.	3	0	9	0
Ferns, in variety, dozen	4	0	18	0	Poinsettia, dozen ..	12	0	15	0
Ficus elastica, each ..	1	6	7	0	Solanum, dozen ..	9	0	12	0
Foliage Plants, var., each	2	0	10	0	Tulips, dozen pots ..	6	0	9	0

CUT FLOWERS.

Holly and Mistletoe now commencing for Christmas decoration.

	s.	d.	s.	d.		f.	d.	s.	d.
Abutilons, 12 bunches ..	3	0	to	6	Lilies, White, 12 bunches	0	0	to	0
Anemones, 12 bunches ..	0	0	0	0	" Orange, 12 bunches	0	0	0	0
Arum Lilies, 12 blooms ..	5	0	8	0	Lily of the Valley, 12				
Asters, 12 bunches ..	0	0	0	0	sprays ..	6	0	9	0
" French, bunch ..	0	0	0	0	Marguerites, 12 bunches	2	0	6	0
Bouvardias, bunch ..	0	6	1	0	Mignonette, 12 bunches	3	0	6	0
Camellias, blooms ..	2	0	4	0	Pelargoniums, 12 trusses	1	0	1	6
Carnations, 12 blooms ..	1	0	2	0	" scarlet, 12 trusses	0	4	0	9
" 12 bunches ..	0	0	0	0	Poinsettia, 12 blooms ..	6	0	8	0
Chrysanthemums, 12 behs.	6	0	12	0	Primula (single), bunch ..	0	6	0	0
" 12 blooms ..	0	6	3	0	" (double), bunch ..	0	9	1	0
Daisies, 12 bunches ..	2	0	4	0	Roses, 12 bunches ..	0	0	0	0
Eucharis, dozen ..	4	0	6	0	" (indoor), dozen ..	1	0	1	6
Gardenias, 12 blooms ..	0	0	0	0	" Tea, dozen ..	1	6	3	0
Gladiolus, 12 sprays ..	0	0	0	0	" red, dozen (French)	1	6	3	0
Hyacinths, Roman, 12					" yellow ..	3	0	8	0
sprays ..	0	6	1	0	Stephanotis, 12 sprays ..	8	0	10	0
Iris, 12 bunches ..	0	0	0	0	Tropeolum, 12 bunches	2	0	3	0
Lapageria, white, 12					Tuberose, 12 blooms ..	0	6	1	0
blooms ..	2	0	3	0	Tulips, dozen blooms ..	0	0	0	0
Lapageria, coloured, 12					Violets, 12 bunches ..	1	0	1	6
blooms ..	1	0	1	6	" (French), bunch	1	3	2	0
Lilium longiflorum, 12					" (Parma), bunch	3	0	5	0
blooms ..	6	0	9	0	White Lilac, per bunch ..	6	0	7	6

VEGETABLES.

	s.	d.	s.	d.		s.	d.	s.	d.
Artichoke, dozen ..	1	0	to	2	Lettuce, dozen ..	0	9	to	0
Asparagus, bundle ..	0	0	0	0	Mushrooms, punnet ..	0	6	1	0
Beans, Kidney, per lb.	0	3	0	0	Mustard and Cress, pint.	0	2	0	6
Beet, Red, dozen ..	1	0	2	0	Onions, bunch ..	0	3	0	0
Broccoli, bundle ..	0	0	0	0	Parsley, dozen bunches	2	0	3	0
Brussels Sprouts, ½ sieve	3	6	4	0	Parsnips, dozen ..	1	0	0	0
Cabbage, dozen ..	1	6	0	0	Potatoes, per cwt. ..	4	0	5	0
Capsicums, per 100 ..	1	6	2	0	" Kidney, per cwt.	4	0	0	0
Carrots, bunch ..	0	4	0	0	Rhubarb, bundle ..	0	2	0	0
Cauliflowers, dozen ..	3	0	4	0	Salsafy, bundle ..	1	0	1	6
Celery, bundle ..	1	6	2	0	Scorzoneria, bundle ..	1	6	0	0
Coleworts, doz. bunches	2	0	4	0	Seakale, basket ..	1	6	1	9
Cucumbers, each ..	0	4	0	6	Shallots, per lb. ..	0	3	0	0
Endive, dozen ..	1	0	2	0	Spinach, bushel ..	1	6	2	0
Herbs, bunch ..	0	2	0	0	Tomatoes, per lb. ..	0	4	0	6
Leeks, bunch ..	0	3	0	4	Turnips, bunch ..	0	4	0	6

FRUIT.

	s.	d.	s.	d.		s.	d.	s.	d.
Apples, ½ sieve ..	1	6	to	3	6	Oranges, per 100 ..	6	0	to
Nova Scotia and					Peaches, dozen ..	2	0	6	0
Canada barrel	10	0	18	0	Pears, dozen ..	1	0	1	6
Cherries, ½ sieve ..	0	0	0	0	Pine Apples, English,				
Cobs, 100 lbs. ..	55	0	0	0	per lb. ..	1	6	2	0
Figs, dozen ..	0	0	0	0	Plums, ½ sieve ..	0	0	0	0
Grapes, per lb. ..	0	6	2	6	St. Michael Pine, each	3	0	5	0
Lemons, case ..	10	0	15	0	Strawberries, per lb. ..	0	0	0	0
Melon, each ..	0	6	1	0					



PROGRESS.

ONE of the most remarkable signs of agricultural progress that is going on steadily under the depression, of which it may be said to be an outcome, is a knowledge of soils and manures—how to cultivate the one, how and in what form to apply the other. The thoroughness and exhaustive nature of experiments by which such knowledge is being acquired may well be taken as a guarantee of the soundness and real practical utility of results.

One of the most valuable works in our library is a complete set of annual reports of the Proceedings of the Sussex Association for the Improvement of Agriculture.

This Association was formed in 1881, and the Report of its proceedings that year has especial value, as showing the thorough and careful manner in which the work was begun. Similar associations are springing up in other counties, and it may prove useful if we give a brief account of the details of primary importance in the work of such associations.

The first four rules of the Sussex Association are so important that we give them fully:—

1. That the work should consist of experiments, with the object of ascertaining the most efficacious and economical forms of manures.

2. That the crops experimented upon should be those largely grown in Sussex.

3. That there should, in the first instance, be four experimental stations—viz.:

(a) One scientific station for eliciting information, to be afterwards put in practice in the field.

(b) Three field stations, where the experiments would be carried out in such a way as are, or might be, practised on a large scale.

4. That the three field stations should be upon the three chief geological formations of the county—viz.:

(a) The weald clay; (b) the Hastings beds; (c) the chalk.

It will be thus seen how thoroughly practical and comprehensive the work of the Association has been from the outset. The next step was one of equal importance. Rule 2 naturally gave rise to the query, What are the crops largely grown in Sussex? The agricultural statistics issued by the Board of Trade afforded a complete answer, so that Professor Jamieson, the chemist of the Association, was able to show upon a diagram of the agricultural land of that county the proportion of land devoted to the crops of Wheat, Barley, Oats, Rye, Beans, Peas, Potatoes, Turnips, Carrots, Cabbage, Vetches, &c.; Rotation Grass, Permanent Grass, Hops, and Fallow. Then came the work of selection and mixing of manures for trial upon what were appropriately termed "educational plots," and these plots are of especial interest, as showing how farmers may analyse the soil for themselves, and obtain exact knowledge of its nature and requirements. We invite special attention to this matter on the part of our readers, for the knowledge so gained may be regarded as an indicator pointing to success even now.

Professor Jamieson explains that the essential elements of plants are potassium, calcium, magnesia, iron, phosphorus, sulphur, and nitrogen. A substance containing none of these elements is no manure. A substance containing all of these elements is a complete manure. A substance wanting one or more of these elements is a partial manure. Deprived entirely of any one of these elements the plant cannot live. No excessive quantity of any one element will make up for deficiency of any other element. Rational manuring is the application of all those—but only those—elements which are deficient in the soil. He goes on to show that chemical analysis of the soil properly conducted is the natural and speediest method of ascertaining which ingredient is deficient; but this is an operation which farmers generally will not learn to do for themselves, nor even be willing to pay a chemist to do. Without much trouble, however, and at little or no expense, similar information of the state of the soil may be ascertained by making the soil analyse itself, as it were; in other words, by partial manuring in a systematic manner—*i.e.*, by giving to one patch of land no manure whatever, to another patch of land all the essential elements, and to six others all the essential ele-

ments excepting one, and that excepted one being a different element in each case.

We may explain that so little iron is required in plants that it was rightly considered at the outset that no special plot was required as a test for it, nor was one wanted for lime. The outcome of the analysis was most important, leading as it did to the conclusion that the only fertilisers required by soil generally are nitrogen, potash, and phosphorus. The best form in which these three manures can be used is as nitrate of soda, nitrate or muriate of potash, steamed bone flour, coprolite, and superphosphate, all procured separately, and mixed according to the formula which we have given repeatedly.

#### WORK ON THE HOME FARM.

Ploughing is still being pushed on briskly, especial care having been taken to plough the Mangold land immediately after the roots were cleared off it. We had really a useful green crop to plough in, for in addition to the Mangold tops, Charlock had sprung up so thickly as to quite cover the surface. The showery autumnal weather has been peculiarly favourable to seed germination, and where land is infested by Charlock we were indeed glad to see its seed caused to grow now, so that the plant could be ploughed in, and a considerable outlay for hand and horse hoeing avoided next spring. We still see sheep folded upon Mangold land to consume the leaves. Such a plan could only be justified by great scarcity of food, for the leaves are so valuable for manure that they should, if possible, always be ploughed in. The leaf growth was so vigorous that some men had to go before the ploughs with forks to spread them over the surface in order that they might be quite covered by soil in the ploughing. A little extra labour in deep ploughing at this season of the year is well rewarded by a fine seed bed next spring, for soil so turned up and exposed to the action of frost becomes pulverised, crumbling when stirred in spring like a bed of ashes. We do all the ridge ploughing we can, first of all throwing the soil into ridges, which are at once split asunder by passing a plough along the middle of each ridge, by which means all the soil is moved and the ridges are left high, loose, and well open to the action of frost. In ploughing due attention is given to making enough water furrows on heavy land, and all such furrows are opened into the nearest ditch so as to ensure a speedy passage for rain or snow water. Foul land having much couch grass in it should also be ploughed up and well exposed in order that stirring and cleaning may begin early in spring, and with favourable weather then most of the grass roots may be got out quickly, at any rate much sooner than is possible when land is left unploughed till spring, and then comes up so sodden and heavy that exceptionally fine weather is necessary to render it possible to use harrows upon it.

#### SEEDSMEN'S STANDS AT ISLINGTON.

THE Smithfield Club Exhibition at the Agricultural Hall, Islington, is very satisfactory in the number and quality of the cattle entries this year. It is said that there are not quite so many implement and machinery exhibits, but all available space seems to be occupied. The seedsmen's stands are even more elaborate than usual, and there is an uncommonly good display of roots for such a bad season as the present. Messrs. Sutton & Sons, Reading, have an extensive and handsome exhibit, comprising mounds of their select Mangolds, such as the Mammoth, the Intermediate, the Oxheart, and Golden Tankard, all remarkable for their evenness; fine examples of Champion Swedes and Kohl Rabi being arranged in a similar manner. At the lower part of the stand are samples of Sorghum, the Thousand-headed Kale, Flax fibre, with miscellaneous vegetable farm seeds, and a shield of medals accorded to the firm at numerous exhibitions.

Messrs. J. Carter & Co., High Holborn, have a new and tasteful stand constructed of Wellingtonia gigantea wood, in commemoration of the jubilee of the firm. A series of recesses in front is devoted to samples of seeds, then there are specimens of Tobacco leaf, cut Tobacco, with cigarettes and cigars prepared from the samples grown on Messrs. Carter's Kentish farms. Boxes of lawn and pasture grasses form a pleasing finish to the fore part of the stand, the upper portion being occupied with Green Globe, Elephant, Warden, and Golden Intermediate Mangolds, Green Kohl Rabi, White Globe Turnips and Prizewinner Swedes, all admirable specimens of their respective varieties.

Messrs. Webb & Co., Wordsley, Stourbridge, have provided an excellent exhibit of farm roots, the Mangolds and Swedes being of great size and very even. The most notable of the varieties which this firm has carefully tested are the Champion Yellow Globe and the Mammoth Long Red Mangolds and the Imperial Swede. The samples of these are displayed in conical mounds and comprise a large number of roots. Specimens of farm seeds, Potatoes, including the new Stourbridge Glory and other exhibits, complete a very effective stand.

Messrs. Harrison & Son, Leicester, also have a large number of Mangolds and Swedes, with Potatoes and miscellaneous seeds, Messrs. Hooper & Co., Covent Garden, contributing a stand of Potato seeds and grain samples.

## MANURES IN RELATION TO AGRICULTURE.

[An address delivered by Mr. Edward Luckhurst at a meeting of the Ixworth Farmers' Club, on December 1st, 1887.]

REGARDING the soil as a vehicle for plant food, it is clearly our business as farmers to render its condition suitable for that purpose. In doing this we have first of all to insure thorough drainage and mechanical division. We then draw off superfluous water quickly, causing it to act as a scavenger of the soil, and also as a solvent of fertilising gases which pass into the soil and are taken up by the plant roots growing into it. Water passing thus through the soil gives place to air, which, pressing as it does at the rate of 15 lbs. to each square inch of surface, enters the soil as its pores become open to it. The high importance of this action will be in some degree apparent when it is understood that upwards of 90 per cent. of plant food comes from the air. Professor Jamieson puts it at 97 to 98 per cent., while the French chemist, M. Georges Ville, gives from 93 to 94 parts of plants as derived from air and rain. The difference is unimportant, if we can only grasp the principle and act upon it. Well-drained soil has its temperature raised, and instead of retaining water hurtfully to plant life, it becomes the vehicle of water to plants; it gets rid of noxious matter, and in part opens the soil for the entrance into it of the warm fertilising atmosphere about it, thus promoting what has been termed circulation in the soil. In order to grasp fully how much air and water contribute to the growth of plants, we have only to look at the bulk of a full crop taken from a field; and yet although the small per-centage per acre of chemical ingredients added by us is comparatively trivial, yet without it and the proper cultivation of the soil, all the rest is useless, or very nearly so.

Nitrogen, phosphorus, and potash are the elements of fertility with which we have to keep the soil supplied, but before we do so the condition of the soil must be rendered suitable for it. This fact cannot be too strongly enforced, pointing, as it does, unmistakably to a clear saving upon the wasteful outlay upon manures which has so long been the bane of farmers. I was once asked to inspect a field of Wheat to which a dressing of forty cartloads of farmyard manure per acre had been applied. Notwithstanding this heavy dressing of manure the growth of the Wheat was most unsatisfactory; it was backward, stunted, and yellow, and the worthy farmer was fairly puzzled. My inspection of the soil brought to light the important fact that though firm enough to the tread, it was literally water-logged, and I had to explain that soil kept constantly in a saturated condition by water arising from the subsoil by capillary attraction, is virtually closed to the action of the air; its temperature is consequently always so low that though the roots of plants may exist, they cannot thrive in it, and to apply manure to such soil is clearly a waste of labour, time, and money.

Turning now to manures, I will take first of all muck, or farmyard manure, as being that in general use, and with the nature of which all of us are more or less acquainted. It may, however, be as well to remind you that a ton of farmyard manure contains 9 to 15 lbs. of nitrogen, 9 to 15 lbs. of potash, 4 to 9 lbs. of phosphoric acid, and 75 per cent. of water; the difference in quantity of the manurial constituents arising from the difference in the age of the animals and of the quality of the food given them. The chief merit of such manure is that it contains all the necessary elements of plant food; it may therefore be used without risk of harm, and with a feeling of certainty that some good will follow its application to the soil. I maintain, however, that such practice is vague, careless, slovenly, and wasteful. I go farther, and assert positively that the manufacture of farmyard manure is a costly and extravagant process for which there can be no justification. See what it involves! The breeding or purchase of cattle, the free use of straw for litter, the cost of attendance and food throughout winter and spring, loading carts and carting to the manure heap, the turning over and mixing of the heap, carting again and spreading upon the land, with a certain heavy per-centage of loss of ammonia, to say nothing of the risk of losses among cattle, and a slow return, if any, upon the outlay incurred in the purchase of beasts, especially if they be Irish. Some muck there always must be at every homestead, but I would restrict the manufacture of it to the quantity necessary for root culture, but even then it should be used in combination with artificial manure. Farmyard manure so combined in root culture is of especial value from the large per-centage of moisture it contains, for if only we can get our Mangolds and Swedes established early in the muck placed in the furrows in readiness for them, its moisture enables the young plants to grow so freely that the crop becomes fully developed, passing unscathed even through such a long period of drought as we have had this year.

I could quote various authorities in support of my views here, and may instance Ville's outspoken assertion that "The farmer who uses nothing but farmyard manure exhausts his land. For whence comes the manure but from the soil? As a fact farmyard manure does not make up for the loss of phosphates, lime, potash, and nitrogenous matter which it had to submit to through the carrying away of part, at any rate, of the crops grown on it." In his seventh lecture he shows that no difference exists between chemical and farmyard manures except with regard to appearance and bulk, and he asks if this is the case why should we be condemned to produce farmyard manure at great cost and trouble if chemical manures can be procured more easily, adding, it is vain to bring forward the mechanical action of farmyard manure for the fertilisation of meadow land without its aid proves that this is not indispensable.

I may here give an example of results arising from a trial of farmyard manure and chemical manure in my own practice. A large piece of permanent pasture held in reserve for hay was divided by a road into

two equal parts, alike in every important respect, and I resolved to try the effect of muck on one half and chemical manure on the other. The farmyard manure at the rate of thirty cartloads per acre was applied in autumn towards the end of October; its effect was soon visible, the herbage assuming a lively green hue and making growth while the weather was mild and open, so that it presented a striking contrast to the brown stunted appearance of the other half. In the following February this part was dressed with chemical manure, consisting of half cwt. nitrate of potash, three-quarter cwt. nitrate of soda, half cwt. mineral superphosphate, and half cwt. steamed bone flour per acre, procured separately from a reliable source and mixed at the farm. The effect of this dressing was remarkable; the herbage starting into growth quickly soon took the lead of the other, eventually yielding a crop of hay twice the bulk of that obtained from the farmyard manure.

Subsequently the use of muck was discontinued altogether on the hay pastures, and the effect of a regular annual dressing of the chemical manures was a steady improvement in the whole of the pasture, which so far as the hay crop was concerned was very little, if at all, affected by drought, for the application of the manure by the end of February or early in March ensured an early strong growth and a full crop of hay. Experience has shown the importance of this early dressing, for if it is not used till April a month's growth may be lost, apart from the risk of drought and subsequent waste of manure.

A comparison of the cost of the manures used in my experiment was equally in favour of the chemical manures, which cost only 23s or 24s. per acre, the additional outlay involved in the mixing and sowing being a mere trifle. The farmyard manure at 3s. per load represents an outlay of 90s. per acre, to which a considerable additional sum must be added for carting and spreading. To the popular but erroneous idea that the effect of chemical manures is of an exhaustive rather than permanent character, I am bound to say after many years of experience, that if rightly used in well balanced proportions the effect is entirely satisfactory, a gradual but marked improvement being visible in the poorest soil. As an example of this I may mention another case in my own practice. I once had a small seven-acre meadow on the top of a hill, and some 300 feet above the homestead of a small Sussex farm. This meadow, from its peculiar position, had probably never had a manure cart upon it, and when it came into my hands the pasture was so poor as to be worthless. Here was quite a unique opportunity for testing the effect of chemical manures, and I gladly took advantage of it. The same mixture of 2½ cwt. per acre of phosphates, potash, and nitrogen was applied with satisfactory results in the first year; it was continued every February, and eventually the yield of hay from this meadow was fully 2 tons per acre. Now, this was a poor, thin, silicious soil, but I have found the same mixture of manures answer equally well in the calcareous soil of this county. I am not alone in this, and may mention that the Rev. B. Porteus Oakes had the mixture applied to a piece of young permanent pasture at Hawkedon Rectory in the spring of this year, with such satisfactory results that he intends having it used upon the whole of his meadows next season.

It should be mentioned here that pure home-mixed chemical manures generally (in the proportions given in the prescriptions of Professor Jamieson, issued by him for the guidance of the Association under his able management), have been used by myself on the poor thin soil of the Hastings sand formation, and also extensively in this county, on light soil at Nowton, mixed soil at Wyverstone, and heavy soil at Stanningfield, Depden, and Thurlow. Avoiding tedious details, I may usefully add that the effect of the manures upon all the ordinary corn and root crops has in every instance been entirely satisfactory, and I am confident that without such aid I should have failed in my efforts to store with fertility the poor land which came under my care in 1885.

(To be continued).

## METEOROLOGICAL OBSERVATIONS.

CAMDEN SQUARE, LONDON.

Lat. 51° 32' 40" N.; Long. 0° 8' 0" W.; Altitude, 111 feet.

DATE.	9 A.M.						IN THE DAY.				Rain
	Barometer at 32° and Sea Level.	Hygrometer.		Direction of Wind.	Temp. of soil at 1 foot.	Shade Temperature.		Radiation Temperature.			
		Dry.	Wet.			Max.	Min.	In sun.	On grass.		
1887.											
Nov. & Dec.											
Sunday .....	27	Inches.	deg.	deg.	S.W.	deg.	deg.	deg.	deg.	In.	
Monday .....	28	29.750	49.7	49.2	S.	41.2	51.6	47.9	65.7	45.2	0.082
Tuesday .....	29	30.008	44.9	42.9	S.	41.7	51.3	35.8	65.6	29.5	0.331
Wednesday .....	30	29.856	39.8	39.4	N.	41.7	43.7	38.9	49.4	38.9	0.031
Thursday .....	1	29.866	37.4	33.2	N.	41.2	43.4	32.2	61.2	27.4	—
Friday .....	2	30.232	43.0	42.4	S.W.	40.2	49.8	32.8	54.1	28.0	—
Saturday .....	3	30.497	44.4	44.0	S.W.	40.8	49.3	32.7	61.2	40.8	—
		30.251	44.1	42.4	S.W.	41.6	47.4	43.0	52.6	38.7	—
		30.033	43.0	41.9	—	41.2	43.1	39.0	53.5	35.5	0.391

## REMARKS.

27th.—Fair till 8.50 A.M.; a sharp shower with squall fr. m 9 to 9.20 A.M., then fair; fine and bright after 11 A.M.  
 28th.—Fine, but rather foggy early, bright morning; some sunshine in the afternoon, but slightly foggy; heavy rain at night.  
 29th.—Overcast all day; showers from 4 to 4.39 P.M.; fine and bright evening and night.  
 30th.—Cloudy early; fine bright day.  
 1st.—Dull and misty morning; bright for an hour or two in the morning and in the evening; warmer throughout.  
 2nd.—Cloudy early; bright warm day.  
 3rd.—Fine, and still warm.  
 A pleasant winter week, with a good deal of sunshine. Temperature rather more than 1° above the average, and 5° above that of the preceding week.—G. J. SYMONS.





## COMING EVENTS

15	TH	Royal Society at 4.30 P.M.	Richmond Horticultural Society's Annual
16	F		[ Dinner.
17	S		
18	SUN	4TH SUNDAY IN ADVENT.	
19	M		
20	TU		
21	W	Royal Meteorological Society at 7 P.M.	

### THE POTATO CROP—SUPERTUBERING.

**C**HRYSANTHEMUMS having had a fair share of attention of late, just as Roses have in their season, it may not be unseasonable to refer to a subject that, if less attractive in its nature, is not less important—the Potato crop of the year, as influenced by summer heat and drought, autumn rains, and early winter frost. The latter has probably done little, if any, injury in some of the southern counties, but in a great Potato-growing district in the north it is not easy to suggest how many tons of fine Potatoes were ruined in November.

During August and the early part of September, when the ground was parched by the great heat and prolonged drought, the growing or languishing plants had such an exhausted appearance, especially on high and not deeply worked and well-enriched land, that fears were entertained of the crop of tubers proving a failure. They were small then, and their growth so much arrested that supertubering was generally anticipated on the occurrence of heavy rains, with the dreaded result, that had been experienced in some previous years, of neither the original nor the subsidiary crop possessing substantial value. The late crops are now being alluded to that are mainly relied on for affording a supply of food for the population during a period of seven months, or from the end of September till the end of June, for new Potatoes are not cheap enough for the multitude till towards the close of the last-named month.

A few years ago Regents, Victorias, and White Rocks were chiefly employed in field culture in the large Potato-growing districts for winter and spring use; but these have been practically superseded, and mainly by the Magnum Bonum. There is probably more of this variety grown than all others put together for market purposes during the period named, and its introduction and increase have been of unspeakable advantage to both cultivators and consumers. Its strong constitution has enabled it to practically escape the murrain in wet summers, and the same vigour has proved its capacity for struggling through a season of drought, and giving a good reward for those who treated it well and waited for the harvest; but some growers did not wait long enough, while others waited too long, and both have been the losers.

During the supertubering and disease eras in the Potato's history, when the crops were so liable to ruin, the preventive that was more generally advocated than any other was early lifting, or taking up the crops as soon as the tubers attained a fair size, whether their skins were set or not, before the falling of the autumn rains that were so commonly followed either by the murrain or

a second growth of tubers, both of which were at times disastrous. Early varieties were also strongly recommended, and not a few of their admirers predicted that in no long time late kinds would be obsolete. That view of the future was not sustained, neither, it may be remarked, was it entertained by the most extensive cultivators, whose crops extend over hundreds of acres and are sold in thousands of tons. They tried the earlies of those days and found them wanting. The crops were too light, and the land after their removal became infested with weeds, which if not destroyed—and this involved expenditure—injuriously affected the succeeding Wheat crop, or rendered its cleaning costly. A subject so great and of wide practical import as growing Potatoes for the use of a nation, cannot be grasped in all its bearings by growers of them in gardens with an acre or two in fields for a family's consumption. Yet it is perhaps correct to say that those who have, with a few exceptions, grown the least in bulk or area have written the most about the claims of varieties and methods of culture; and, moreover, as the majority of teachers have practised—admirably it may be conceded, but on a small scale—in the south, their advice, especially in the early lifting of the main crops, as above indicated, has been substantially useless to the cultivators of the north, from whence the bulk of the produce is drawn for general sustenance.

The well-intentioned southern tutors founded their advice on early lifting on their experience that unripe tubers with tender skins, which ruffled at the slightest touch, would, if stored thinly and kept dry, soon set fresh skins, being then equal in appearance to crops that ripened in the ground; while they further found that those unripe tubers, though necessarily sad and watery when cooked, became under the treatment referred to, at least to a fair extent, mealy and of good quality. Granting all that, the advice was all the same lost on northern cultivators. In the south the tubers of the main crop varieties, Regents, Rocks, Victorias, and others that ripen in late summer or early autumn, often attained a fair useable size before the rains fell, but in the north at the same time the tubers were only about the size of Walnuts; and even if they had been large enough for use, storing the yield say from a plot of 100 acres thinly, and keeping the tubers dry to set their skins and develop starch, would be no easy task. It was, in fact, impracticable, and experience proved it was the best policy to allow them to remain in the ground as long as they could grow, or till October.

Let it be understood these northern Potato farmers are not ignoramus wedded to old customs and practices, but intelligent educated men, who bring science to bear on their work, and who possess both the means and the will to do it well. They do not hesitate to invest freely in labour and fertilisers in bringing the land into the best condition mechanically and chemically for the crop on which so much depends, this practice being adopted because, as tested by the value of the produce, is found to be the most economical. A penurious system in culture is the most costly of all, and though in many cases it is feared it is a matter of no choice, it has none the less contributed more than anything else to the unproductiveness of the land, and to its depreciation in value; and what is more, nothing will restore it, if it is to be restored, but higher culture—better worked and cleaner land sufficiently fortified with the essentials of growth for the production of bountiful crops. If artificial aids, of whatever kind, can be brought to bear on the matter, let

them be utilised; but to rely on them in any measure as substitutes for high culture can only end in disappointment, and natural methods of improvement must never be overlooked. Good field culture of Potatoes means a yield of from 10 tons to 20 tons per acre, and when these weights are produced, as they are, and the produce realises £4 a ton, as it has, there is a margin left as a "living" off the land, even if half the value of the crop is invested in its production, and there can be no substantial interest without a good investment.

The Potato crop this year is unusually heavy, *Magnum Bonum* being taken as the staple variety. The plants had "potatoed" before the rain fell, and those who followed the advice of early lifting, which appears to have clung to the public mind, for avoiding supertubering, had to regret their action when they saw the results of another five or six weeks of growth. The early lifted produce does not represent half a crop, the tubers being small, malformed, and scarcely saleable; while those that were left are large, some perhaps too large, well shaped as a rule, the crop being more than twice as heavy as the prematurely lifted, and at the least thrice as valuable. This is not the result in one district alone, but in several widely separated. The growth after the rain and till very late in the autumn was wonderful. The heavy yield was not, however, gained by "supertubering" of the old ruinous kind, but in not a few instances was the produce of a distinct second growth of tubers which attained a full marketable size, most of them setting their skins firmly, but not all. In some cases the original tubers increased in size, attaining abnormal dimensions, yet not necessarily unshapely, but extending and "thickening out," a mark on them showing the first and second growth clearly; but in most cases the original tubers remained almost stationary, some of them merely bulging out and spoiling their appearance, the second crop—that formed on "spears" direct from the stems, eventually proving infinitely the heavier and better in appearance and quality.

This is "supertubering," no doubt, but of a profitable kind, the form that was dreaded by the early diggers being exactly the reverse. This when it appeared in connection with weaker growers and earlier ripeners than the *Magnum Bonum*, consisting of young tubers pushing from the eyes of the first formed, or crop proper, and clinging like limpets to the rock; this "supertubering" commencing with a heavy fall of rain after a period of drought that brought growth to a standstill, and so far prematurely ripened the tubers, that, though small, they could not increase in size, but instead produced a clustering progeny. Several of these second tubers were often found larger than the originals, yet not large enough, nor good enough for table use, though they answered for seed, producing fairly good crops; but those from which they sprang were of no use for seed, but only fit for pigs, probably doing these little, if any, good, for the tubers were hard, the starch having apparently been drawn from them by the supertubers. It is to be noticed that though the first formed tubers were so far ripened that they could swell no more, the eyes or buds were not developed, or they would have pushed growths in a natural way, producing stems and leaves above ground. This is what the earlier and fully ripened Ashleaf varieties have done when left in the ground, but the late kinds seldom. The supertubering described, when very pronounced is disastrous, and where the original tubers were large enough for use it was wise to dig them before the rain, if even a moderate crop could be secured, as it often could in the south; hence

the advocacy of the plan that was, with rare exceptions, impracticable in the north for the reason stated. Experience shows, too, that though early lifting may answer with *Regents* and others that ripen about the same time, it does not answer, nor is it needed, by the later and stronger *Magnum Bonum*, for the early diggers of this have certainly been very great losers.

But, as intimated at the commencement of these notes, there is danger in the other extreme of leaving the crops in the ground too long, and being overtaken by frost before they can be secured. This has occurred with many in some parts of Lincolnshire, and possibly elsewhere. The growth was so strong and so late that the withering of the haulm was waited for, this materially reducing the cost in facilitating the work of lifting. This was in full swing in November—all the hands that could be obtained being employed in it. It was a race against the portending winter. In some fields the tops were pulled up, but the cavities thus left admitted the frost that immediately followed, and damage was done. Hundreds of tons were heaped and covered with straw, frost coming before they could be earthed sufficiently, and it is feared much loss will be sustained in that way. Some readers in the salubrious south may possibly imagine that the winter of last year is referred to. They may not know that between the 14th and 20th of November this year that frost penetrated the ground to the depth of 5 inches, and that skating on deep ponds was indulged in. It is thought by some growers that the extent of the injury will affect prices, and as they can afford to do so it is not unlikely they will "hold" their stocks for a time and wait the issue of events.

Enterprise as well as ability is not wanting amongst the best of the Potato farmers. They are on the look-out for new varieties and try many that promise to answer their purpose. They must be good growers, bearers, keepers, and cookers, with white (not coloured) skins, and preferably rough. Red and purple Potatoes are effective at exhibitions, and some of them of excellent quality when cooked; but there is no appreciable demand for them in the markets, and they are therefore not likely to be cultivated on an extensive scale. Potatoes for exhibition have been fashionable during the past few years, and the "fancy" has done good in stimulating raisers and cultivators in the path of improvement. There is a plethora of varieties now. Some very good ones have no doubt been introduced, and their merits as croppers and cookers determined at Chiswick. These must have been widely distributed, and gardeners and others who have grown them might do good by directing attention to such as they have found to possess substantial advantages over older varieties. So far, after many trials in fields, the *Magnum Bonum* has held the premier position. *Regents* and some others are grown for special markets, but on "*Magnums*" reliance is mainly placed for producing the rent and something over; but it has a rival in the field now—a variety that does not figure prominently in trade lists, that has not been exhibited and certificated, nor frequently "mentioned" in the press. Its name is *Imperator*. Since 17 tons per acre were grown on a Yorkshire farm in a less bountiful Potato year than this, the extent of its culture has only been limited by the supply of seed. It is a robust, yet sturdy and upright grower, with round to oval, rough skinned, small eyed tubers, few being too small for market, but some too large, and the quality and appearance so good that the London salesmen who have received consignments are asking for more. Closer planting will reduce the size, but a few

“big ’uns” can be sorted out without much grumbling from a crop of 200 sacks, or 20 tons to the acre, this having been produced on good warp land. Imperator is believed to be of German origin and will perhaps be heard of again.—A NORTHERN GROWER.

[Relative to the second growth of Magnum Bonum Potatoes this year, we have samples before us, grown by Mr. Thomas Holman, a medical gentleman and intelligent cultivator, in Sussex. Mr. Holman was advised to dig up his crop when the rain commenced in September, to avoid supertubering. Fortunately he only acted on the advice to a small extent. The early dug tubers are small, malformed, and unsaleable in comparison with the later sample which developed afterwards. These were produced from the main stems of the plants above the first formed tubers, and are from 3½ to 4 inches long, faultless in shape, with well set skins, and in all respects excellent, the crop being 400 bushels, or 13 tons per acre. Mr. Holman also sends us a second growth sample, dug while the plants were green. These are much smaller and of good shape, but with ruffled skins, which spoils their appearance. Probably if kept in a dry dark place they may be found of fairly good quality very late in the spring. The samples demonstrate the great loss that would have been incurred by taking up the whole crop, as was advised, prematurely. After the extreme heat the ground was like a hotbed when the rain fell, hence the rapid growth and maturation of the second crop. The original tubers do not seem to have enlarged as appears to have been the case in the north, where the crops were, perhaps, less advanced to maturity when the rain fell there.]

### “OLD LACHARME.”

Now that the Chrysanthemum mania, as my friend “A. C.” calls it, has lessened, there may be the possibility of something being heard about the Rose, and, by-the-by, I do not think that we Rose lovers have any right to complain, for when the month of July sets in, is not the Rose the prominent theme of the Journal? Its pages diffuse a delicious “attar,” and we almost expect to find it printed on rose-coloured paper. So that while we are getting about our denuded beds, we may well let the Chrysanthemum lover have his fling. It is everybody’s flower, which the Rose is not. She is too dainty to put up with the smoke and dust of a great city, while the Chrysanthemum (I will not say revels in it) seems to grow quite as well there as anywhere else; and as I want to remind the readers of the Journal that there is after all really such a flower as the Rose, I cannot do any better than put down a few notes concerning one whose death has made this an “*annus memorabilis*” to the Rose lover, and whom even a quarter of a century ago we used to know by the familiar title of “Old Lacharme.” It was not because there was a young Lacharme, as in the case of the Guillots, but it was, I think, a title of affection for one who was then in the prime of life. We never used to speak of the elder Guillot as old Guillot, but “Guillot père,” while of the galaxy of Rose raisers at Lyons—Guillot, Schwartz, Levet, Boucharlat, Ducher, Liabaud, Pernet, and others—Lacharme stood a very Saul amongst them, nay, I venture to say a head and shoulders above all the Rose raisers of the world.

It is now more than twenty years since I first visited Lyons as a Rose lover. I had been there fifty years ago. Rumours had reached us that old Lacharme had at last gained the much-desired yellow Hybrid Perpetual, and as I was on my way to Paris I was asked to go down and see it; but, alas! when I got to the nursery and was cordially welcomed by Lacharme, he told me that he had been deceived, and that what the bud promised the opening flowers had belied, and that the long-wished-for Rose had not yet arrived. There was about the man the unmistakable signs of hard work, and in all his conversation you noted that his love for the Rose was not of a purely commercial character. Like every grower for sale, he liked it to be a source of profit to him, but it was above all necessary that it should be a source of pleasure, and ambition also that his name should be associated with it. There was not about his nursery, any more than in most French nurseries, any attempt at tidiness, but everywhere signs of hard work, nor did his garden contain that enormous number of plants that used to be found

about Brie Comte Robert. His rôle was essentially that of a raiser of new varieties, and how well he fulfilled his mission the catalogues of the present day tell us plainly. He worked hard, and his health was not of the best. He felt that Lyons was at times too cold for him, and not so favourable for the seeding of his Roses as he wished, and so a few years ago there was a proposal made by him to the son of one of our principal Rose nurserymen that he should join him and migrate further south towards Montpellier or Toulon. It however came to nothing, but it was an evidence of the strong will and enthusiasm of the old man, for then he was approaching his threescore years and ten.

I have called him the most successful Rose raiser that has ever lived. Success is to be measured, not by the amount of money made by flowers nor the quantity of seedlings sent out, but by the quality of those that bear his name; and there is this to be remembered, that while many Rose growers who have let out large numbers of varieties have purchased many of them from others and then sent them out in their own name, Lacharme never put his name to a Rose that he did not himself raise, and that therefore his success as a Rose grower cannot be measured exactly with others. He is handicapped in this respect.

We have the means of testing this success, for the National Rose Society has published in its catalogue of exhibition and garden Roses the names of the raisers of the flowers admitted into it, and also the year of their being sent into commerce. There are 115 Roses in the list, and of these there are several synonymous Roses, which brings the list down to about 105, and of these eleven are Lacharme Roses, while the remainder have been raised by twenty-eight other raisers. Thus, while he has raised one-tenth of the whole number, the others have contributed a little more than three each, taking them in the aggregate. This of itself would be a sufficient indication of his success, but this is still more remarkable when we take the names of his Roses. Of dark Roses he has raised Alfred Colomb, Charles Lefebvre, Louis Van Houtte, and Xavier Olibo; of light Roses, Captain Christy, Catherine Soupert, Comtesse de Serenye, Hippolyte Jamain, Madame Lacharme, Victor Verdier, and Violette Bouyer. What a galaxy of grand Roses is here! All, with the exception of Comtesse de Serenye, which I do not think will long last amongst our exhibition Roses, owing to its habit of becoming dirty (unless when the weather is of the finest), likely to last for many a long year, as some of the choicest favourites of the Rose growers, and appearing in almost every exhibition stand, and some of them the very grandest Roses in existence. Who will ever put aside such flowers as the grand old “Charley,” or Louis Van Houtte, or Captain Christy, Madame Lacharme, or Violette Bouyer? and surely such a man ought to be ever held in affectionate remembrance by those to whose pleasure and enjoyment he has so largely contributed. Nor was he idle amongst Teas. To him we owe the robust and ever changing Madame Lambard and the old but beautiful Madame Willermoz.

There was another class of Roses which, although not exhibition flowers, are amongst the most beautiful of our garden Roses, I mean those that are sometimes called Hybrid Noisettes, those beautiful white Roses of the Boule de Neige type. He worked vigorously at these, and it was from them that he hoped to obtain his yellow Perpetual, and in 1860 Madame Gustave Bonnet was sent out. In 1861 he produced Louise Darzens, and in 1862 he brought out Madame Alfred de Rougemont, named after the wife of a Swiss lover of Roses; Lady Emilie Peel and Perle des Blanches in 1864, followed by Baronne de Maynard; and in 1867 by Boule de Neige, the greatest favourite in this class, Coquette des Alpes, often with a faint edging of pink. In 1872 came Perle des Blanches, and in 1877 Madame François Pittet. These all run upon the same lines. There is in some of them a faint suspicion of yellow, especially when in the bud state, and for continuous blooming and purity of colour it is hard to beat them.

It will thus be seen from this rapid survey of the old man’s lifelong work what pleasure and enjoyment he has been the means of giving to the Rose-loving community, and it was a graceful thought that impelled the members of the National Rose Society to send, through their Secretary, a letter of sympathy with his widow in her bereavement. There is no Lacharme to carry on the work, and his name will be associated with some of the finest Roses we have; for while it is never safe to predict what may be done in floriculture, there is a limit beyond which it does not seem possible to go. We have reached it in Fuchsias, Pelargoniums, &c., and the experience of the last few years, while it indicates fresh grooves into which we may run, at the same time teaches us that it will never be easy to beat such Roses, in their own line, as are associated with the honoured name of François Lacharme.

In appearance he was a man of about middle height, latterly much stooped with age and hard work. He had a fine expressive countenance, and what was really a noble forehead; as one who



knew him well said the other day, had he been an educated man he might have excelled in any calling. He had a bright eye and a kindly manner, while his whole bearing gave you the idea, that of all the adjectives which might be applied to him, the most appropriate was that which the French have given to their new President, *honorete*.—D., Deal.

### RANDOM THOUGHTS.

As we approach the end of another year it seems proper to look back on the past and also to try and see into the future. I think horticulturists may congratulate themselves on the progress made in 1887. Various beautiful and valuable additions have been made to our already large stock of plants, and the displays made at the very numerous shows throughout the year all over the country have been excellent in every particular. While I write, Chrysanthemums are the rage, and the gardening papers teem, and have teemed for a few weeks past, with accounts of shows in all quarters. Little wonder need be expressed at the great popularity of the Chrysanthemum. It is a flower which, in an almost endless variety of shape, size, and colour, lends a charm to a period of the year which is naturally dull, and for this alone the Chrysanthemum is justly appreciated.

Orchids seem holding their own well, and it seems to me that the more they are known, and the more it becomes spread abroad that they are not so difficult to cultivate, or so very dear (in many cases at least), as many people think, the more they will be grown. Many beautiful Orchids can now be obtained at prices that place them within the reach of most people, and anyone with ordinary intelligence can, by the aid of information conveyed in the gardening press and in books on the subject, attain to success in the culture of many Orchids. When we think that not only is there endless variety and wondrous beauty in the Orchid family, but also that the flowers of most of the lovely members of this very remarkable family last a long time when cut and placed in water, it appears not at all surprising that Orchid collecting and Orchid growing have become important branches of commercial horticulture. The energy and enterprise of Orchid importers is very remarkable, and all quarters of the globe are now explored, heavy expenses incurred, and numerous perils encountered in the search for new varieties, or else increased quantities, of the Orchid family. Orchid literature, too, is now becoming very important, and numerous works have been, and are being, published on the subject.

Another large and continually increasing branch of commercial horticulture is Grape culture. When we go round the places about London which are devoted to Grape-growing, or visit the Channel Islands, where seas of glass are to be found, a somewhat overwhelming feeling comes to us; the visitor is inclined to ask the question, "Is not Grape growing going to be overdone soon?" Now it appears to me that there is ample room for all who at present are engaged in Grape culture. Whether in the future it will be overdone time alone can tell, but at present good Grapes are always in demand at a fair price, and I trust that such may long continue. Liberal treatment, judicious manuring with the proper manure, moderate cropping, thorough ripening, and careful packing, these are some of the things to be considered in commercial Grape culture, especially if the highest price in the market is aimed at. Some growers strive to obtain tremendous crops of second-rate Grapes, and renew their Vines frequently, considering that they make as much the one way as the other.

Regarding the question of the demand and supply of gardeners, I am sorry to say that there seems an overplus of gardeners in the country. So many places have been reduced, that large numbers of gardeners of various degrees of experience have been thrown out of employment, and it does not appear that in this respect much improvement can be looked for. In the future this evil can only be remedied by fewer young men entering the gardening profession, and as a matter of course this will happen if there is not a brisk demand for gardeners in the country.

A seeming injustice in connection with commercial horticulture is, that those noblemen and gentlemen—now very numerous—who devote their gardens and hothouses principally to growing for market, are not subjected to the same rating, and it would appear that there is some cause for complaint here. The gardening press has been advancing with the times, and much energy and enterprise are now devoted to the carrying on of the various papers which record the doings and sayings of horticulturists. It is to be hoped that the future, in spite of "depression," may have in store for horticulture a long period of success, and that the already large army of the lovers of horticulture for its own sake, or else as a means of honourable livelihood, may be increased.

There are many parts of the globe still unexplored which may reward the collector of the future with many rich and rare gems of

floral nature; there are many branches of horticulture at home that have new fields to be explored, new wonders to be displayed; and in roaming abroad or plodding at home, there is much to be done that will aid to extend our knowledge of plant life in all its wondrously diversified forms. May 1888 prove a very prosperous year for horticulture; may those who take pen in hand at its close be able to record many new discoveries, many instances of increased success in culture at home, and a greatly increased enthusiasm for, and appreciation of, a portion of Nature's family, that contains amongst it endless variety of form, colour, and taste, that ever gives a charm or conveys a delight, and which has in the past been a means of solace, of refreshment, and of pleasure to many thousands of our fellow creatures in all conditions of life. It may confidently be stated that in the future horticulture will be no less enchanting, no less beneficial, no less elevating, than it has been in the past; and if such prove the case, it will be to increased numbers, with increased facilities of enjoyment, and with all the advantages that this nineteenth century can convey.—SCOTIA.

### KITCHEN GARDEN WALLS—THEIR

#### OCCUPANTS.

FEW things probably tend to give more character to a private gardening establishment than kitchen garden walls well covered with trained fruit trees. It requires some years of care and attention to produce such ornamental specimens. I say ornamental, because in some cases they have little else to recommend them than their appearance in being well trained, not having perhaps for years produced that which they were really planted for—a good supply of superior dessert fruit. This shows only too clearly that while so much time has been devoted to the symmetrical balancing of the branches, the roots have been left to take care of themselves, and by rambling far beyond the border originally prepared for them, have done nothing but produce an abundance of unfruitful growth. Some people think a good wall is all that is required. Trees planted against that must be successful; but experience proves that success is not so easily attained. Wall trees have a decided advantage over standards or pyramids if proper attention be only paid to root and branch, but should this be neglected, then I consider they are growing under greater disadvantages than those trees planted in the open, as the latter reap the full benefit of the autumn and winter rains, also the refreshing rains and dews during the growing season, so essential to all vegetable growth. Trees planted close to walls are to a certain extent cut off from these natural advantages by the height of the walls, and the projections in the shape of copings, &c., besides the foliage suffering after such hot days as were experienced last summer by radiation during the night from the hot bricks. A thick brick wall, with its massive foundations, has a great power of absorbing moisture from the soil surrounding the ball of the tree, and unless this is counterbalanced by repeated waterings and mulchings, the roots will naturally ramble in search of one of its greatest and indispensable agents—moisture. This will be found in the cold subsoil, and often a great distance from the tree. When roots reach such a position, then commences the downward career of the tree as fruit-producing. Even should it continue to give fruit for a few years, it will fall far short of the standard wall trees ought to produce. It is hardly necessary to explain here how such trees should be root-pruned, as this has been often fully detailed in your columns, but carrying out those details properly will be the only way to get unfruitful trees again into a full bearing condition.

Another point of great importance to wall trees where their roots are in restricted borders, or restricted to a given space, is that they must have a thorough soaking early in the season; especially so in regard to Peaches growing against a south wall. Good crops of these have often been lost through shedding their flower buds during the months of March and April, consequent on the dryness of the border during that critical period when the roots require a good supply of water to properly develop their blossoms. I consider two of the most essential points in connection with successful fruit culture on walls is to have thorough control over their roots, a good supply of water to be afforded to both root and branch at the proper season.

Before concluding, I should like to draw attention to the north walls, which are seldom seen to have other or better occupants than Morello Cherries. That a few trees of this valuable Cherry for late work is most useful I will admit, but a great quantity of the same fruit may be grown on dwarf bushes for early and mid-season work, thereby giving valuable wall space to other and probably better fruits. These that I will mention I have proved to succeed year after year, therefore I can recommend them after successful trials, and not through any fancy idea of what might be obtained. One of the most useful is Louise Bonne of Jersey Pear.

This has never failed to produce a good crop of fine fruit, thus prolonging the season of this favourite Pear quite a month or five weeks. It has surprised many growers to see it so fine at such a late date, when probably theirs have been over for a month or more. I have exhibited it the last week in November in grand condition, and even now, December 3rd, I have several good fruit left. Some may wonder how trees in such a sunless position could ever ripen wood sufficiently to produce good fruit. I consider the secret is in a well prepared border, thoroughly drained, and raised above the natural level of the land, with a free mixture of lime rubbish and the like well worked about the roots. Among other fruits that have also proved very satisfactory are Beurré Rance Pear; also Coe's Golden Drop and Jefferson Plums, if protected with mats, will provide choice dessert fruit for weeks after the supplies have been consumed from west and east walls. Gooseberries, too, I have seen most plentiful under the same conditions, and it is surprising how long such fruit will hang if only protected from rain and frost. Several others, such as cooking Plums and late dessert Cherries, may all find a place on the north wall, and seeing that the season of such good fruits may be prolonged, I think it is well worth the time and attention in trying to secure this end, but the returns greatly depend upon the condition of the roots, and this all depends upon how the borders are formed.—R. PARKER, *Impney*.

### ROYAL HORTICULTURAL SOCIETY.

A SPECIAL general meeting of the Fellows of this Society was held on Tuesday afternoon in the Royal Albert Hall, Sir Trevor Lawrence, Bart., M.P., in the chair, for the purpose of receiving a report from the Council, and to consider the statements and proposals contained therein.

The CHAIRMAN, in opening the proceedings, explained that a question had been raised as to the strict legality of that meeting; but that need not give rise to any difficulty in carrying any resolutions which might be passed, as the Council would call a special general meeting subsequently to give legal validity to any resolution. He then went on to say that in pursuance of the resolutions come to by the Society to make the best efforts they could to secure such a site as was pointed out by those resolutions, it had been found that any site offering any advantages would be so extremely costly that it would practically preclude the Society, in its present pecuniary position, from going to such an expense. Several sites—among others some on the Embankment—had been examined; but, having regard to the great cost, the Council thought they could not recommend the Society to embark on any of them. The result was that they were left in a position to some extent unfavourable. Personally he entirely agreed with the remarks made in the *Times* that morning. He did not think the Commissioners of the 1851 Exhibition had dealt either generously or liberally with the Society. (Hear, hear.) When it was considered that the Society had expended close upon £100,000 in beautifying the gardens and in building arcades, &c., the whole of which had been practically swept away by the action of the Commissioners, he thought it certainly not too much to say that they had not been dealt with with very great liberality. (Cheers.) Sir Lyon Playfair—there was no disguising the fact—whose was the principal voice in directing the operations of the Commissioners of 1851, had never viewed the Society very favourably; and Sir Lyon Playfair had himself told him that the Commissioners felt it necessary to make an income out of the Gardens for their own purposes. As they were aware, Her Majesty the Queen had expressed a desire that the Society should remain in South Kensington, and the Council had felt to a certain extent bound by the expression of Her Majesty. He did not think the Commissioners had felt equally bound; and, at all events, the only proposal which had emanated from the Commissioners had been one that the Society should pay them a rental of £1000 a year for the use of what remained of the Gardens, after the requirements of the Imperial Institute had been attended to. The Council calculated that it would involve the Society in an expenditure of at least £2000, and inasmuch as that was more than the total income of the Society, they did not see their way to entertain any such proposals. It was the unanimous opinion of the Council, because several gentlemen who held opposite views had either sent in their resignations or were proposing to do so—that the connection of the Society with South Kensington had been one gravely disadvantageous to the former. (Hear, hear.) The question was what were they to do? The view of the Council was that they devote their attention to the maintenance of the Chiswick Gardens and the conduct of plant, fruit, and vegetable trials there, and possibly the establishment of a school of gardening, the immediate engagement of such premises in a convenient and central position as might suffice for office requirements, the safe housing of the Lindley Library, the meetings of the Society's Committees, and its fortnightly shows, to the maintenance of which they attached great importance. He might mention that the Society had been in possession of Chiswick Gardens for sixty-five years, the results of which would be thrown away if they ceased to occupy the Gardens. (Hear, hear.) It was impossible to get similar accommodation anywhere else for the purpose which those Gardens had secured so many years, and he confessed it could not be but absolutely destructive to the Society and to any hope of future utility, and a serious national loss, were anything to happen to Chiswick Gardens. (Cheers.) The Gardens would not cost more than £1500 a

year, and that was less than they had been costing. He was very glad to see that whatever might happen to the Society the Scientific Committee had no intention of being dissolved, and he understood that the Fruit and Floral Committees were animated by a like intention of continuous vigorous existence. (Hear, hear.) These two circumstances were very gratifying. In regard to the past, the work of the Society ought not to be forgotten, and one could scarcely go a day's walk or ride into any part of the kingdom without seeing evidence of the past activity of the Society in the beautiful introductions by Douglas, by Fortune, and many others, and it ought not to be forgotten that it was in no small degree that owing to the fact that the Society sent Fortune to China, and that he was engaged by the East India Company for the purpose of introducing Tea into India. Indian Tea will next year be imported in larger quantities than China Tea, the first time in the history of this kingdom. (Hear, hear.) Another point was whether the publication of the work done by the Society might not be dealt with in a more systematic and satisfactory way. Something in the way of more detailed reports might be drawn up and periodically published. With regard to the financial position of the Society, at the end of the year they would probably be as they foresaw in June last—viz., they should be in debt about £1000. Speaking for himself, he was not alarmed at the sum, as in past years the Society had been more heavily in debt. On one occasion it was in debt £17,000, and on another £10,000. The fault had been, if they might gather wisdom without criticising the past, that when they had had a term of prosperity they immediately said the whole savings must be spent, and on one occasion a large dinner was given at Chiswick which was attended by a large number of the fashionable world. When they had spent the whole of the money they used to get into debt as rapidly as possible again. There would be an end of this sort of thing if the Society were to devote itself strictly to the advancement of practical and scientific horticulture, and they would not then be catering for the fashionable world, of which, he thought, they might entertain a legitimate contempt. That fashionable world changed from day to day, and what it loved one day it hated the next. If they put their trust in the fashionable world they would be depending on a broken reed. The Chairman then spoke about the charter, and mentioned that he had received a letter from the Society's solicitors, and it appeared one of the most difficult things in the world, having once had the advantage of being under a charter, to get rid of it. He was sorry to say it was very much like the old man of the sea who got round Sinbad's neck. [The letter, which the Chairman read, stated that it would take from four to six months at least to obtain a new charter, and the cost would be about £200. In the case of opposition the expenses would be considerably increased. The letter concluded, "On the whole, therefore, it seems that the new charter is the only feasible mode of reconstructing the Society."] The Chairman went on to remark that as far as the Council were concerned, they were perfectly prepared to resign their position in view of enabling the Fellows to take what course they considered advisable. He might add that to carry on the Society the Council, or any modification of it, should have sufficient funds, and it had been estimated that £3000 a year was not at all too much to ask in view of the great work which had been done by that ancient Society. (Cheers.) He was quite sure that the Society had not flourished and had not done as good work latterly, owing to the fact that it had been at the beck and call of the Commissioners of the 1851 Exhibition. (Cheers.) With regard to the debt of the Society, had it not been for the loss on the Liverpool Exhibition the accounts would about balance. He thought there would be no difficulty in point of time of getting premises immediately for the purposes of the Society, in order that the fortnightly shows might still be carried on, supposing that they got encouragement from the Fellows in that direction. He had received promises of donations amounting to about £900 towards establishing the Society in its new home, and he had also received encouraging promises of healthy support from numerous firms connected with horticultural work, while others were anxious to know more of what was proposed to be done before they decided whether they would be able to help the Society. (Cheers.)

Replying to some questions, the CHAIRMAN said a strong feeling had been expressed about the desirability of increasing the numbers of the Council. So far as the Council were concerned, they were most willing that that should be done, but that could only be done under a supplementary charter and not under the existing one, because the latter distinctly stated that the Council should consist of fifteen members.

Mr. SMEE asked if every member of the Society was not jointly and severally liable for the debts of the Society.

Dr. HOGG replied that there was no personal liability.

Mr. SMEE said he would be willing to subscribe towards obtaining a new charter, and he moved that steps be taken in that direction.

Major LENDY thought there would be no difficulty in raising the necessary funds, and seconded the motion.

Mr. SHIRLEY HIBBERD urged that the present Council "should not be allowed to go" after their experience of 1872. (Laughter.)

The CHAIRMAN said it was not with any idea of showing the white feather that the Council had made the suggestion.

Mr. SHIRLEY HIBBERD said he did not attribute motives, but he wished to come to business. He considered that a great deal more might be done at Chiswick than had been the case in the past, and the unnamed rubbish which had been grown there should give way to things of sterling value, and Chiswick should be a place of final proof only.

Every person sending to Chiswick should be charged, thereby making an honest income for the Society. (Hear, hear.)

MR. PEARSON said it appeared necessary that a new charter should be obtained, and they should take steps to form a new Committee, partly of the members of the Council and partly of the general Fellows, to draw up the draft of a new charter.

MR. J. J. WATTS seconded the motion.

MR. HAUGHTON thought that the Society could be governed under its existing charter. The minority on the Council, of which minority he was one, looked upon the question as a financial one. Funds should be obtained, and these could not be obtained from the purely scientific class of the community. (Hear, hear.) The Society had once a subscription income of £10,000. In 1874 it was £8000, and in three years it was reduced by half by the taking away of privileges of the Fellows of the Society. If the horticultural world meant to have a purely scientific Society they must put their hands in their pockets. That was the plain issue between the two sections, and unless the pure horticulturists were prepared to supply the money it was useless discussing the question. The Society must go forward on one of those two lines or fall between them. (Cheers.)

The CHAIRMAN pointed out that when the Council were catering for amusing the fashionable Fellows enough money was not taken at the doors to pay for the bands (hear, hear), therefore Mr. Haughton was labouring under a delusion. (Hear, hear.) Anything more hopeless than endeavouring to get money out of the South Kensington people for the Horticultural Society never entered into the mind of man. (Laughter.)

MR. VEITCH said he should like to pay a tribute to the memory of the late Mr. Geo. Eyles, a pupil of Sir Joseph Paxton, who had done so much for horticulture. (Hear, hear.) He was sure the majority of those present agreed to cordially thank Sir Trevor Lawrence and the other members of the Council who had conducted the affairs of the Society under all difficulties. (Hear, hear.) They, however, wanted to see the Council enlarged if the Society were to go on. They should also have a paid secretary, who would be called upon to devote the whole of his time and knowledge to the Society. (Hear, hear.) If they could have committees for various purposes, and were to act more on the lines of the Royal Agricultural Society there was still a future before them. It was no use endeavouring to get the Society to work under rules made in 1809 (hear, hear), and unless there was a remodeling, he did not think they would have any future. (Hear, hear.)

The Rev. W. Wilks considered that fifteen members of Council were quite sufficient, and that "too many cooks would spoil the broth." All that was needed was that the Council should alter its rules and regulations to suit the popular and democratic sympathies of the present day.

Professor M. FOSTER thought that some reconstitution of the Council should take place in order that its members might be in closer touch with the Fellows.

MR. THISELTON DYER said they wanted something more than money, and that was a horticultural policy, and he did not think they could look for assistance from the public, unless they had a very different programme. They had catered for the fashionable world and had had skating rinks, fashionable gardens, and the like, but it was not horticulture. (Hear, hear.) To speak plainly, the game was up—(Cheers)—and they must stick to their last and try to impress upon the public their earnestness by doing good work in the future. (Cheers.)

After some further discussion the foregoing resolutions were embodied in a resolution moved by Dr. Masters, to the effect that the Council carry out the suggestions in pars. 6 and 8 of the "Appeal" below issued, and "That this meeting requests the Council to consider the desirability of obtaining a supplemental charter, and meanwhile requests them to vary the byelaws in such a manner as to insure the full control of the Fellows over the election of officers and Council of the Society at the annual general meeting." The following gentlemen were also nominated by the same resolution as a Committee:—Sir Trevor Lawrence, Bart., M.P., Baron Schroder, G. F. Wilson, Prof. Foster, A. Smee, H. J. Pearson, H. J. Veitch, Shirley Hibberd, George Paul, and Dr. Masters.

MR. PEARSON seconded the motion, which was carried with four dissentients.

The following statement issued by the Council to the Fellows of the Society shortly before the meeting, was sent to us last week, with a request that we should not publish it till after the meeting:—

THE Council of the Royal Horticultural Society request the horticulturists of the United Kingdom to read and consider the following statement and appeal:—

1, The grounds at South Kensington, known as the Gardens of the Royal Horticultural Society, having been devoted to the Imperial Institute, the Council endeavoured, in obedience to the wishes so graciously expressed by Her Majesty the Queen, the Patron of the Society, to obtain from the Royal Commissioners of the 1851 Exhibition such a site as would justify them in advising the Fellows to remain at South Kensington.

2, The Royal Commissioners were, however, unable to offer any adequate site, and gave the Council distinctly to understand that the erection of offices, committee rooms, &c., on their land would not be held to confer any claim whatever, either legal or moral, to the use of the conservatory and Gardens for the purposes of the Society. The negotiations consequently came to an end. An

informal offer has since been made by the Royal Commissioners to let a portion of the Gardens and the conservatory to the Society at a guaranteed rent of £1000 a year, which with rates, taxes, and maintenance would involve an expenditure of £2000 a year at least, a sum far beyond the resources of the Society.

3, The Society has been in existence for eighty-three years, having been founded in 1804, and incorporated by Royal Charter in 1809. It has done much to advance the interests of practical and scientific horticulture, and it is the recognised authority on all horticultural questions. In addition to the valuable work of the Scientific Committee, presided over by Sir J. D. Hooker, K.C.S.I., C.B., F.R.S., new and rare plants, fruits and vegetables, collected abroad or raised at home, have been continually submitted, in large and increasing numbers, to the judgment of the Fruit and Floral Committees, whose verdicts are accepted without question. The Society has also continuously carried on valuable trials of plants, fruits, and vegetables at Chiswick. It has published during the last three years the following—viz.,

"Report of the National Apple Congress held at Chiswick, October, 1883."

"Report of the Orchid Conference held at South Kensington, May, 1885."

"Report of the National Pear Conference held at Chiswick, October, 1885."

"Report of the Primula Conference held at South Kensington, April, 1886, and of the Orchid Conference held at Liverpool, June 30th, 1886."

"Report on the Effects of Frost on Vegetation during the Severe Winters, 1879-80, 1880-81—published in 1887."

4, The Council are of opinion that the connection of the Society with South Kensington, however promising at first, has proved adverse to its true interests and permanent welfare. They recognise that altered circumstances require a complete reorganisation of the Society on a more popular basis. They believe that, while local horticultural societies attract local support, a central metropolitan society (to which local societies may be affiliated) is, in the interests of horticulture, indispensable. Under analogous circumstances the Royal Agricultural Society prospers, although there are local societies in every county of the kingdom.

5, The Council do not believe that the Society can be carried on any longer under the trammels of the existing charter, which was granted in 1860 in view of a wholly different state of things; nor do they think a charter will be requisite for its future working. They believe that the numbers of the Council should be considerably increased and their mode of election modified and made popular, and that the ordinary work of the Society should be carried on by committees under powers delegated to them by the Council. They hold that the Society should henceforth devote itself strictly to the advancement of practical and scientific horticulture.

6, The view of the Council is that the expenditure of the Society should be reduced as much as possible, and its resources devoted to the following objects:—

(1) The maintenance of the Chiswick Gardens and the conduct of plant, fruit, and vegetable trials there; and possibly the establishment of a school of gardening.

(2) The immediate engagement of such premises in a convenient and central situation as may suffice for office requirements, the safe housing of the Lindley Library, the meetings of the Society's Committees, and its fortnightly Shows, to the maintenance of which they attach great importance.

(3) The publication of periodical reports of the work done at Chiswick, and by the Society's Committees, and on horticultural subjects generally.

7, For many years the nature of the accommodation which the Society has been able to obtain at South Kensington has virtually prevented meetings being held for the discussion by the Fellows of points of interest in the practice of horticulture. It is essential that these meetings should be resumed, and it is believed that they will be of great value in bringing together those who take an active part in British horticulture. It is also hoped that such meetings would give an opportunity for the consideration of the numerous directions in which the rural economy of the country seems likely to be modified by the substitution of horticultural for agricultural methods.

8, The Council would recommend that the subscription should be in future £2 2s. for Fellows, and that a grade of Member or Associate, at £1 1s., should be created for professional and practical gardeners, who have rarely hitherto belonged to the Society. They calculate that the maintenance of Chiswick will cost £1500 a year, and that for the other purposes of the Society a further sum of not less than £1500 a year will be required. During 1887, 150



Fellows have paid £4 4s., and 623 Fellows £2 2s., making a total of £1938 6s., a sum altogether insufficient for the working and requirements of the Society.

9, In conclusion, the Council believe that the extinction of the Royal Horticultural Society would be regarded by all interested in horticulture as a national loss. The history of the Society, and the good work it has done, and is doing, entitle it to the consideration and support of the horticultural world, to whom the Council make this appeal. They address it with equal confidence to amateurs and to the trade, in the belief that their interests are identical, and that for the protection and advancement of these interests the maintenance of the Royal Horticultural Society is essential. The Council have had difficult duties to perform. While they are willing to continue to discharge these duties, if desired, they believe that the best course would be for them to place their resignations in the hands of the Fellows, at the end of the year, so as to leave the Society entirely unfettered. But they consider it due both to the Fellows and to themselves to say that, unless they receive assurances of adequate support, in response to this appeal, the Society must necessarily come to an end.

10, The favour of an early answer is requested on the enclosed form. The donations would be devoted to the cost of establishing the Society in its new home, and to similar purposes.



#### ORCHID NOTES.

A NOTION prevails that Orchids generally are extremely difficult to grow unless houses are specially erected for them, and this, it is almost needless to add, has a most deterrent effect on would-be growers. Now we have no Orchid houses, or even many places that would be considered suitable for them, yet no great difficulty is experienced in growing and flowering a fairly good selection. What we can accomplish may safely be undertaken by various other cultivators with every prospect of ultimate success. Nor is the original outlay at all disproportionate to the amount of pleasure to be derived from the flowering of a small collection of Orchids, or even in excess of what would have to be expended in the purchase of a small collection of ordinary stove and greenhouse plants. The novice need not procure the most expensive forms of the various species, this luxury being reserved until he can appreciate their distinctive features. For the present he must be content with the more common varieties, and strive to grow these to perfection. All are more or less beautiful. The majority remain fresh for a much longer time than do ordinary flowers, and are certainly totally different as far as their formation and the habit of growth is concerned.

#### CYPRIPEDIUMS.

These are among the most easily cultivated, and if not particularly beautiful, their quaintness attracts attention. *C. insigne* is the best known of the genera, and a very serviceable plant it proves. At the outset I made the common mistake of keeping it in an ordinary stove temperature, whereas it should be given heat only when forming fresh growths. Supposing the plants flower any time during the winter or early in the spring, they ought if possible, soon after the "slippers" drop off, to be placed in a plant stove or forcing vinery to complete their growth. It is unwise to be constantly pulling them to pieces and repotting, but if badly crowded with growths, or it is desirable to increase the stock, they may be carefully pulled to pieces prior to the commencement of active growth, and repotted in a compost consisting of one-half rough fibrous peat and charcoal crocks, and sphagnum moss in about equal proportions. Then if the pots are well drained there is little danger of the compost becoming sour, a contingency always to be guarded against in Orchid culture. Some mix turfy loam with the compost, but this practice ended disastrously when tried here, and we use this for the annual spring top-dressing of established plants only. When growing freely they require plenty of water at the roots. In June all should be transferred to a cold frame or pit, and there be kept well supplied with water and shaded from bright sunshine. In September, or later if need be, they may be taken to a warm greenhouse, conservatory, or living room to develop the flowers already showing at nearly every fully formed growth. In a cool house or room, if kept properly attended to, the flowers will remain fresh for about two months. This cool treatment frequently induces the formation of twin flowers, though we have had none

as yet, but can point to plants in 7-inch pots bearing fully twenty perfect blooms. As far as my experience goes all the insigne group require much the same treatment, and I have found *C. insigne* Maulei quite as easily grown and much attractive than the type. Mr. Cypher at Cheltenham has a large stock of *C. insigne punctatum* (rightly considered the best in the group), and this with them succeeds admirably under much the same treatment as I have just detailed.

The old *C. barbatum* with its dull variegated foliage and equally unattractive flowers I would not cultivate, backward as we are in Orchid culture, but much admire *C. barbatum nigrum* and *superbum*. There is no necessity to place either of these in a cold frame to induce flowering. Once well established in a porous compost similar to that just described, and which, let me add, appears to suit nearly all the *Cypripediums*, they will flower readily enough in July and August, and keep fresh and beautiful for at least six weeks. Nor do I believe in keeping them when in flower long in a cool house or room, this being apt to induce a second flowering soon after re-introduction into the ordinary plant stove or warm fernery where ours are kept. A cold frame or pit is, as I found to my cost, positively injurious to the heat-loving *C. Dominionum*, *C. caudatum*, *C. Boxalli*, *C. villosum*, *C. Spicerianum*, and *C. Lawrenceianum*. Each and all of these are very distinct and beautiful and are easily grown. The last named has handsome mottled foliage and fairly pretty flowers. It appears quite at home in our mixed house, and the only variety just named that evidently needs a brisk stove temperature is *C. Spicerianum*. This I hold to be an excellent plant, as if grown in a rather loamy compost forms fine broad foliage and flowering freely in November. *C. Dominionum*, *C. caudatum* and *caudatum roseum*, *C. Sedeni*, and others with long twisted petals are all easily grown and very attractive when in flower. No resting or drying is necessary or advisable. They simply need a sweet rough compost, a fair amount of root room, and water whenever the surface soil approaches dryness. We have *C. villosum* and *C. Boxalli* in a warm fernery, and without any particular treatment other than that just given, they invariably flower strongly and are fairly attractive.—  
W. IGGULDEN.



TO OUR READERS.—In consequence of an accident on the machine, which is always a possible contingency in printing, the whole of our last week's impression could not be delivered at the usual time. We regret the unavoidable delay, and the disappointment which some of our readers may have thereby experienced.

— THE proposition made at the recent meeting of the NATIONAL ROSE SOCIETY that, if possible, an exhibition should be held in Dublin in 1889, will no doubt be favourably received by many of our Rose-growing readers in Ireland. There is also every reason to suppose that a good exhibition could be obtained, but whether the scheme is practicable will depend upon the support the Dublin Horticultural Society may be prepared to give.

— THE WINTER IN SCOTLAND.—A correspondent writes:—"Winter has been hovering around for some time and now seems to have closed his grip upon us in Scotland. A snowstorm has been general over the country for the last five days, depths of 1 to 8 inches undrifted being reported up to the 10th inst. In South Perthshire the general fall does not exceed 1½ inch. For the past three nights successively, 12°, 16°, and 14° of frost have been registered. There is every appearance of a continued storm." We may add by way of contrast that on the morning (13th inst.) we received the above note, the thermometer registered 50° in the open air in a suburban garden near London.

— LAST Tuesday, the 13th inst., was a busy day amongst horticulturists in the metropolis. The chief event was the special meeting of the Royal Horticultural Society at South Kensington, which is reported on another page. On the same day and at the same place the National Auricula, Carnation, and Picotee Societies, together with the Committee of the National Dahlia Show, and the Royal Horticultural Society's Floral, Fruit, and Scientific Committees. Then at the Covent Garden Hotel in the evening, the Horticultural Club held a dinner.



— *DENDROBIUM FORMOSUM GIGANTEUM* is shown in plate 308, a grand variety, which flowered last August in the Victoria and Paradise Nurseries. The flowers are of great size, with very broad white sepals, petals, and lip, the last named having an irregular bright orange coloured blotch in the centre. It was first introduced by Messrs. Low and Co., Clapton, in 1856, from Rangoon, but has been frequently imported since in large quantities. The plants do not, however, seem to flourish long under cultivation.

— **GARDENING APPOINTMENTS.**—Mr. W. J. Novell for the past four and half years foreman at Grimston Park, Tadcaster, has been appointed gardener and bailiff to Mrs. Anson, Catton Hall, Burton-on-Trent.

— AT the ordinary meeting of the **ROYAL METEOROLOGICAL SOCIETY**, to be held at 25, Great George Street, Westminster, on Wednesday, the 21st inst., at 7 P.M., the following papers will be read:—“Mean Temperature of the Air at Greenwich from September, 1811, to June, 1856,” by H. S. Eaton, M.A., F.R.Met.Soc.; “Report on the Phenological Observations for 1887,” by the Rev. T. A. Preston, M.A., F.R.Met.Soc.; “Earth Tremors and the Wind,” by Prof. John Milne, F.R.S., F.G.S.; “Pressure and Temperature in Cyclones and Anticyclones,” by Prof. H. Allen Hazen.

— **SAMPLES of ODAM'S HORTICULTURAL MANURES** have been sent to us, but as this is not the best time of year for testing their effect on crops, we must content ourselves by stating that they have been found in the highest degree satisfactory by several of the best gardeners in the kingdom, whose names are included in the list of testimonials before us. We have had proof of the value of the manures of the firm in field culture.

— WE are desired to state that a plant of *DENDROBIUM NOBILE*, at Llanway House, Goldalming, is bearing 264 flowers on thirty-three spikes, the specimen measuring 4 feet 6 inches in diameter.

— **MR. T. JACKSON**, the Hon. Secretary of the **KINGSTON AND SURBITON CHRYSANTHEMUM SOCIETY**, informs us the twelfth annual Exhibition is fixed for November 6th and 7th, 1888.

— **ROYAL BOTANIC SOCIETY, 1888.**—The spring exhibitions of this Society are announced to be held on Wednesdays, March 21st, April 18th; Summer Exhibitions, Wednesdays, May 16th, June 20th; Evening Fête (probable date), Wednesday, July 4th; Promenades, every Wednesday in May, June, and July, excepting exhibition and fête days.

— **MR. W. SPINKS**, Royal Nurseries, Harborne Road, Edgbaston Birmingham, sends us flowers of a **NEW CHRYSANTHEMUM** which he states was “raised two years ago from Etoile du Midi as a sport. Last year it proved very attractive and was much admired. I grew fifty plants this season. It retains its character in every respect as a good grower, free flower, and a great favourite with everyone. I purpose sending it out next spring (March 1st), giving it the name of ‘Hans Niemand.’” The blooms are of medium size with spreading florets, reddish bronze in the centre and golden in the outer florets. It will evidently possess considerable decorative value.

### VINE BORDERS.

Most gardeners are familiar with the turf system of raising young Vines. The advantage of plenty of fibrous roots in laying a foundation for the success of the Vines no one will deny. I have assisted in clearing out many old borders to plant young Vines, and not in one instance was there to be found any appearance of the Vines ever being fibrous-rooted. To keep the long fat roots from running away something must be done. Adding every year to the new-made border as the long roots shoot out I do not advocate. I have experimented in the opposite course—that is, cut the ends of the long roots for a considerable distance back every spring, and by giving them a good fresh made-up mixture, both for outside and inside borders, until it is finished there will be no want of fibrous roots where they should be. I expect to get some heavy guns levelled at me for attempting to touch a Vine root in its onward course; but the Vines so treated here bear ample proof of the system advocated. The size of bunches and general finish are signs that they like the treatment.

The great amount of soil which makes up Vine borders in many cases is only good for keeping moisture and helping the roots to find nourishment where they should not be. Some advocate the

extension system of training; others advise restriction, as well as given degrees of temperature for setting the fruit; but pinch to a joint for training, or fire to a degree for good setting, and your labour is in vain for fruit of the highest quality, unless the root-action is perfect. There is no objection to fibrous roots, whether they be near the Vine or far away; but in many cases they extend across the border and multiply in gravel walks and other places, instead of first occupying the place allotted to them.—T. S.

### *PÆONIA OFFICINALIS* VAR. *LOBATA*.

THE above plant is by many considered distinct enough to merit specific rank, although Mr. Baker regards it merely as a variety of the

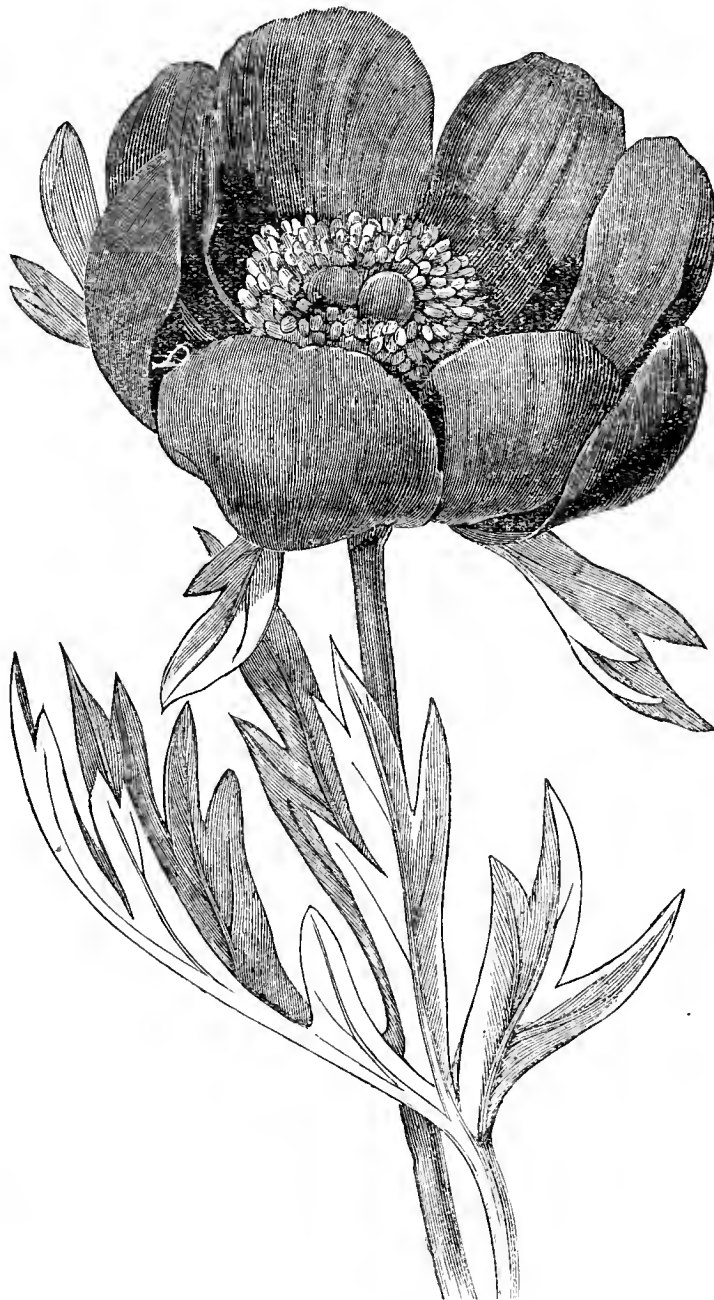

Fig. 61.—*Pæonia officinalis lobata*.

common Peony. Be this as it may, the plant in question, both for grace and beauty, takes a first place even in this handsome genus, and all who cultivate beautiful flowers would do well in adding it to their collections. The type *P. officinalis* has long been considered the female Peony of Dioscorides, so named of course without any consideration of the real distinctions. The leaves are doubly pinnate, with oblong leaflets distinctly veined underneath. It grows from 2 to 3 feet in height, forming a bushy plant. It is the commonest species in gardens, and has given rise to several double flowered varieties, amongst which are Sabini, rosea, blanda, rubra, albicans, &c., a few of which are very beautiful, and indeed all are worthy of attention.

*P. lobata* is dwarfer than the type, differing mostly in being dwarfer in habit, and having narrower and more numerous leaf segments. The flowers are rich cerise salmon, a very unusual colour in a Peony. It flowers with the others in spring.—M. S.



## LILIES AT DUNEEVAN.

THE residence of J. McIntosh, Esq., near Weybridge, is celebrated for its fine collection of Rhododendrons, but the leading feature of this garden during the later summer months are the fine clumps of Liliums, the majority of which find a comfortable home among the Rhododendrons. There may be seen in late summer grand spikes of *L. auratum*, the grand form known as *virginale*, the divisions of which are pure white, and free from the markings seen in the type. It is massive, too, in its flowers and buds, while the foliage and stems are proportionately so. The same robust character is well marked in *platypetalum*, but which has deeper and more intense markings, and in some instances, as in *macrophyllum*, the crimson spots emerge into a crimson-stained band in place of the gold which is so much admired in the typical *auratum*. These Lilies find their requirements exactly suited to a degree among the Rhododendrons. If proof were needed as to what they enjoy here it is; protected from early spring frosts, so detrimental to them in their youth, by the foliage of the Rhododendrons, they grow unchecked, and being sheltered from the sun at their roots, they attain to great perfection. But the chief features among the Lilies in bloom were the grand clumps in full flower of *Lilium auratum rubro-vittatum*, some spikes bearing as many as nine superbly coloured flowers. In this variety the golden band of *auratum* is replaced by one of crimson, which merges into lake.

By far the most remarkable example of Lily culture was that of *L. krameri*, a slender-growing species at all times, but here it had quite outgrown itself and was in such vigour as I have never seen before. This lovely Lily was between 6 and 7 feet high, and had borne nine of its exquisitely shaded blossoms. The cultural requirements of *Lilium krameri* as usually set forth are many and varied, and I have seen a large bed containing nearly 1700 of its bulbs, and which had flowered very freely. In this case the bed is of very sandy loamy peat raised several inches high and fully exposed to the sun. From another source I learn that to grow it to perfection it should be grown in cow manure and sand, while in the case under notice it is simply left alone; the bulb in question which has produced the nine flowers this year having occupied the same position in the Rhododendron bed for the past eleven years, which in itself is the greatest proof of the requirements of this Lily I have ever seen, for in spite of its exquisite shading and general loveliness it is as a rule a difficult Lily to establish. While speaking of its cultural requirements it may be well to state that no two plants occupy the same position, some being exactly opposite in this respect. As regards the cow manure for this species, I can say it is not used at Duneevan, nor is it likely to be, nor should I from past experience of it attempt the use of it myself. One thing is certain, it does not get this or any other manure in the mountainous regions of Senano or on the hills near Kioto, where it grows wild at an elevation of 3000 to 4000 feet. Whether the Japanese use it under cultivation I do not know, but let its requirements be what they may, Mr. McIntosh is undoubtedly to be credited with the production of the finest spikes of it up to the present time, and as this Lily has annually increased in strength and the number of flowers produced, it is only fair to assume that even this may be surpassed another year. With this, as with the majority of Lilies in this garden, they occupy positions in the peat beds among the Rhododendrons, and in each case while their stems and buds ascend into the open sunlight and air, the base is well sheltered by the ample foliage of the Rhododendrons. I mention this, for it is an important point in Lily culture, and it is surprising how much sun they will endure, provided the ground is sheltered in which they are planted.—J. H. E.

## ROYAL HORTICULTURAL SOCIETY.

DECEMBER 13TH.

THE exhibits were not very numerous on this occasion. the seedling *Calanthes* from the President's garden and the Holborn Primulas were the leading features, with some Orchids, and several new Begonias from Chelsea. There was a large attendance of members of the Committees, and unanimous votes of thanks were accorded to the Chairmen for their services during the year.

FRUIT COMMITTEE.—Present—Dr. Robert Hogg in the chair, and Messrs. T. Francis Rivers, J. Lee, J. Willard, W. Denning, C. Ross, T. J. Saltmarsh, A. H. Pearson, James Smith, J. Burnett, J. Woodbridge, H. J. Veitch, Wm. Paul, R. D. Blackmore, Sidney Ford, P. Crawley, and G. Bunyard. Several exhibitors sent samples of Apples and Pears, but none was of special note except one variety from Messrs. Pearson & Son, Chilwell, called the Newton Wonder, of which good-sized fruits, yellow flushed with red on one side, were shown. Sir H. Thompson, West Moulsey (gardener, Mr. A. G. Hookings) also sent a dish of *Stachys affinis*, a new vegetable from Japan, with small and spiral tubers, white, and somewhat resembling the texture of the Jerusalem Artichoke.

FLORAL COMMITTEE.—Present—G. F. Wilson, Esq., in the chair, and Messrs. J. Fraser, G. Duffield, H. Herbst, W. Goldring, J. Hudson, R. Dean, T. Paines, B. Noble, B. Wynne, H. M. Pollett, J. Douglas, H. Ballantine,

J. Dominy, W. Holmes, J. O'Brien, J. Walker, H. J. Lendy, Amos Perry, E. Hill, H. Turner, W. Wilks.

Messrs. J. Carter & Co., High Holborn, exhibited a large group of about 200 well grown Primulas in pots, vigorous yet compact plants, with large heads of richly coloured or delicate flowers, representing a number of distinct and excellent varieties. The principal of those shown were the following: Holborn White Improved, single, large flower, fine substance; Elaine, Fern-leaved, pure white very large flower, and long leaves; Holborn Magenta, rich magenta crimson; Holborn Vermilion, very bright; Holborn White, Fern-leaved, compact truss of large flowers; Holborn Prince of Wales, double rosy salmon, tall branching trusses; Holborn Ruby Fern-leaf, very free and bright; Holborn Snowflake, double white, neatly fringed; Holborn Carmine, Holborn Blue, and Holborn Novelty, white with a rose edge. A silver Bankian medal was awarded for the group.

Mr. T. S. Ware, Hale Farm, Tottenham, showed several plants of *Hellebore* varieties, including *caucasicus*, *angustifolius*, and *Madame Fourcade*, an even-shaped and large flower. Plants of *Sarracenia purpurea* and *Iris Histro* were also sent, the latter with four or five pale blue flowers. Mr. J. James, Woodside, Farnham Royal, Slough, was awarded a vote of thanks for several good varieties of Primulas, the flowers large, pure white, mauve, rich crimson, purple, or magenta. Messrs. H. Cannell & Sons, Swanley, Kent, exhibited a collection of seedling *Canus*, very diverse in colouring and extremely showy. Some were yellow spotted with orange, others pure yellow; some were scarlet edged with yellow, and others of the most intense scarlet or crimson (vote of thanks). From the same firm came plants of Primulas, one named *Bridesmaid* having flowers of great size, substance, and excellent form, the colour a soft rosy blush; also *King of the Primulas*, a fine single variety of an exceptionally rich crimson hue.

Sir Trevor Lawrence, Bart., M.P., Burford Lodge, Dorking (gardener, Mr. Biekerstaffe), had a large and handsome group of seedling *Calanthes*, chiefly varieties or hybrids from *C. Veitchi*, *C. vestita*, and *Limatodes*. Some of the most noticeable were—*C. Veitchi splendens*, flowers of great size, deep colour, and white centre,  $2\frac{1}{2}$  inches across from apex of upper sepal to the tip of the lip, the latter being  $1\frac{1}{4}$  inch in diameter; *C. Sedeni*, very deep in colour and compact in the spike; *C. amabilis*, large flowers, pale blush, white centre; *C. burfordiensis*, very deep rosy crimson, with reflexing sepals and petals (vote of thanks); *C. rubro oculata*, white, with an intensely rich crimson in the centre; *C. Veitchi lactea*, creamy white; *C. nivea*, flower large, creamy white, with a yellow centre; *C. luteo-oculata*, pure white, with orange centre; *C. p rphyrea*, a pretty, neat, bright rose flower,  $1\frac{1}{4}$  inch across, the lip rounded; *C. rosea*, flower very large, blush; *C. dubia*, newly white, and *C. sanguinaria* (certificated). Plants of *Cypripedium Leeanum maculatum*, *Aethanthus grandiflorus*, and *Epidendrum pallidiflorum*, with over a dozen panicles of small creamy white flowers (cultural commendation).

Messrs. J. Veitch & Sons, Chelsea, exhibited a box of flowers of *Rhododendron* hybrids and several hybrid *Begonias*, including *John Heal*, *Adonis* and *Winter Gem*, a cross between *B. acotrana* and a tuberous variety; the foliage is peltate, dark green, and toothed at the margin, the flowers dark scarlet (vote of thanks). F. G. Tautz, Esq., Studly House, Hammersmith (gardener, Mr. Cowley), showed a group of Orchids, chiefly *Cypripediums*, including *C. Argus Moensii*, a beautiful variety, with large dark blotched petals; *C. Io*, *C. Ashburton's* var. *calospilum*, *C. Amesianum*, and *C. nitens*; *Lycaste plana rubroglossa* with white petals and a crimson lip, and a fine variety of *Odontoglossum*. R. J. Meuses, Esq., Cambridge House, Camberwell (gardener, Mr. A. Simpkins), sent a plant of *Cypripedium Harry-anum*, a new species imported from Siam by Mr. Renier in 1886 with *C. callosum*; it is supposed to be a natural hybrid between *C. Lowi* and *C. villosum* (vote of thanks). A. S. Smith, Esq., Silvermere, Cobham, was awarded a vote of thanks for plants of *Lælia acuminata* and *Zygopetalum Mackayi*. Mr. R. J. Guilbert, gardener to Miss Mansell, Queen's Road, Guernsey, sent flowers of *Chrysanthemum Guernsey Hero*, a sport from Mrs. Cass Carey; and Mr. Burnett, Depdene Gardens, sent twin flowers of *Cypripedium insigne*.

## CERTIFICATED PLANTS.

*Adiantum Reginae* (H. B. May).—A handsome Fern, suggestive of *A. farleyense* in the size of the pinnules, which in some cases exceed  $1\frac{1}{2}$  inch in diameter. The fronds and habit are compact, and the colour is a fresh bright green.

*Primula sinensis Bridesmaid* (H. Cannell & Sons).—A grand single variety, with flowers  $2\frac{1}{2}$  inches across, the corollas very thick, well formed, and of a soft rosy blush tint, very delicate and charming.

*Chrysanthemum Lord Eversley* (G. Stevens, Putney).—An incurved variety, a sport from Princess Teck, pure white, of fine form and substance, quite distinct from the parent, with a greenish centre when opening, and becoming pure white afterwards.

*Pteris claphamensis* (W. Soper, Esq., 307, Clapham Road, S.W.).—A pretty dwarf Fern, described as a hybrid between *P. tremula* and *P. serrulata*. The fronds are triangular in form, about 5 inches long by the same in breadth, pinnate, with long divided pinnæ at the base, the margins serrulate. It is compact in habit, and is likely to make an extremely useful decorative Fern.

*Nerine Manselli* (John L. Mansell, Esq., 2, Somerset Terrace, Guernsey).—Flowers very large of a bright rosy tint, mauve tinted externally, and about twenty in a head.

*Calanthe sanguinaria* (Sir T. Lawrence, Bart., M.P.).—A grand variety with very large flowers of an intensely dark red colour, by far the darkest form yet obtained.

## CARNATIONS.

CARNATIONS of all types are amongst the most valued of our hardy border plants, but hitherto there has been no variety which could truthfully be described as suitable for bedding purposes or for massing in groups. This is mainly due to the tendency which all possess in greater or less degree to spindle for bloom, necessitating an amount of staking which is both troublesome and unsightly. Many will therefore welcome the new crimson *Clove Paul Engleheart*, spoken of in last week's issue

of the Journal, which supplies a want in this direction. Its dwarf sturdy habit and stiff flower stems, added to the rich colour and powerful fragrance of its blooms, make it a most desirable bedding variety, while the quiet tone of its strong grey-green tufts is pleasing even in the depth of winter.

The great saving of labour in making use of a plant of this character where large masses of colour are required during the autumn months is obvious. Though it is a mistake to suppose that Carnations can be left alone year after year to take care of themselves with good effect, yet they are hardy, need no coddling whatever, and the second year after planting gives the most satisfactory results. The only trouble required is layering a sufficient number every autumn to keep up the stock, and it is very doubtful whether any other plant will give so great a return of pleasure for the small amount of culture it requires as this Carnation. Already a break into another and distinct shade of colour is foreseen, and it is therefore hoped that Paul Engleheart will be the forerunner of a

who devotes special attention to Chrysanthemums, and his able assistant, are to be congratulated on the success of this "home Exhibition."

#### EARLY VERSUS LATE VINE PRUNING.

We were told last week to prune our Vines "directly the leaves are fallen," the reason given being that "the greater extent of young wood keeps the sap more or less in circulation, and causes a certain amount of waste which cannot take place when the Vines are pruned." Now I have an idea that the motion of the sap, which does take place after the leaves are down, is downward to the roots, and is therefore not wasted. In proof of this I have seen the pieces cut from the leaders of young Vines directly the leaves had fallen bleed very much at their base, while the corresponding parts where they had been cut from did not bleed. There is, I should think, a considerable amount of sap in the young wood of a Vine even after the last leaf has fallen; and what I

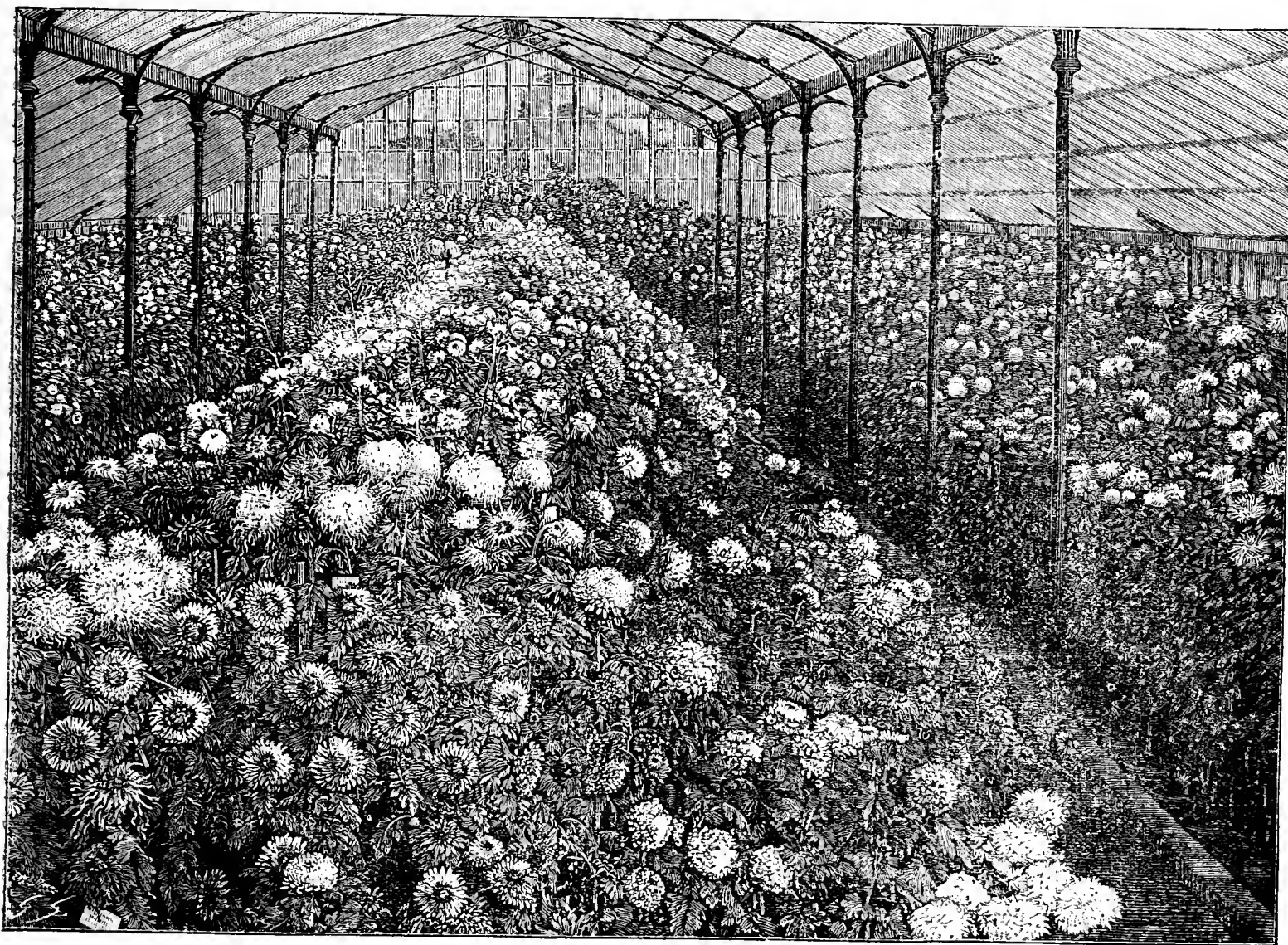

FIG. 62.—CHRYSANTHEMUMS AT CHILWELL.

sturdy race, which will still further extend the usefulness of this delightful hardy flower.—CULTIVATOR.

#### MESSRS. PEARSON'S CHRYSANTHEMUM HOUSE AT CHILWELL.

IN a report of the Chrysanthemums at Chilwell that appeared in this Journal a few weeks ago, the magnitude of the collection was referred to and its effectiveness pointed out. The engraving, from a photograph, will show that too much was not said in favour of this great display, that has been admired by thousands of visitors during the past month. The plants were grown for the purpose of grouping, a considerable number being disbudded for perfecting a limited number of fine blooms, while all the buds produced by others were allowed to expand for producing a mass of flowers of differing size, and suitable when cut for various decorative purposes. A central group was formed down the centre of 100 feet long house, with a path surrounding it, the width of the structure, 30 feet, enabling side banks to be also formed. The plants were well grown and judiciously arranged. A visitor, who has seen many public and private exhibitions, describes the effect as magnificent. Leaving the imagination to fill in the colours it will perhaps be conceded he was not far wrong. Mr. Charles E. Pearson,

would like to know is, whether it is better for the health of the Vine to cut the wood with the sap in it, or to wait a fortnight or three weeks (keeping them under conditions favourable to rest) before pruning. I know that we are continually told to "prune directly the leaves have all fallen in order to ensure complete rest." Still my bold ignorance gives me courage to ask the question, and I hope some of your esteemed correspondents will oblige.—T. C.

[The author of the advice referred to comments on this letter as follows:—"There is no such thing as live wood without sap. If the wood becomes dried to the extent of depriving it of all moisture it is practically dead. After the leaves fall the wood contains no more sap than at any other time during the period of rest with the soil in a moist state and the atmosphere favourable to the flow of the sap, and the sap then in the shoots, assuming them to be pruned, is no loss whatever to the Vines. If the weather be warm when the leaves fall it may not be injudicious to defer the pruning until it becomes cooler and less favourable to the flow of the sap, but there is nothing so dangerous as delay, and nothing so likely to cause waste of the vital forces of the Vines as allowing them to long remain unpruned, and evaporate from parts which are no benefit and must ultimately be removed. A fortnight or three weeks' rest after the leaves fall cannot be described as injudicious, and expresses nearly what was intended. The object was to enforce the ad-



vantages of early over late pruning, and the advice given was safe. We have pruned Vines frequently before all the leaves had fallen, in the case of Vines for early forcing, but some cultivators think, and our experience points in that direction, that the plan is advantageous to the buds that are to remain and furnish the crop on later Vines." ]

### NATIONAL ROSE SOCIETY.

DECEMBER 8TH.

THE annual general meeting of the National Rose Society was held, by permission of the Horticultural Club, in their rooms at the Covent Garden Hotel, Henrietta Street, on Thursday, the 8th inst. There was a good attendance of members, thirty-four being present, including the Vice-President, the Hon. and Rev. J. T. Boscawen, and the Hon. Secs., the Rev. H. H. D'Ombrain and Edward Mawley, Esq. The following were the names of the attendants at the general meeting, though several other representatives of affiliated societies were present at a subsequent meeting to consider the dates of provincial shows. Wm. J. Jefferies, Cirencester; Rev. A. Cheales, Reigate; Jno. Bateman, Highgate; Rev. A. Foster-Melliard, Ipswich; George Paul, Cheshunt; Rev. Joseph H. Pemberton, Romford; W. F. Cooling, Bath; Rev. T. N. Flintoff, Worcester; R. Bloxam, Eltham; Rev. F. Page Roberts, Scole; Wm. Rumsey, Waltham Cross; W. J. Grant, Hereford; Geo. Prince, Oxford; Rev. H. B. Biron, Hythe; Rev. F. R. Burnside, Chipping Campden; Capt. A. Christy, Sidmouth; A. Slaughter, Steyning; E. B. Lindsell, Hitchin; J. B. Hall, Birkenhead; C. T. Horc, Beckenham; T. B. Haywood, Reigate; J. D. Paule, South Hampstead; T. W. Girdlestone, Sunningdale; Geo. Bunyard, Maidstone; J. H. Williams, Salisbury; B. R. Cant, Colchester; Rev. F. H. Gall, Hitchin; Wm. Paul, Waltham Cross; Rev. H. Berners, Ipswich; J. Burrell, Cambridge; R. E. West, Reigate.

The Hon. and Rev. J. T. Boscawen took the chair at 3 P.M., and business was commenced by Mr. Mawley reading the circular calling the meeting. The minutes of the last annual meeting were then taken as read, and at the suggestion of the Chairman Messrs. R. E. West and J. Burrell were appointed scrutineers of the ballot for the election of officers and Committee. The Rev. H. H. D'Ombrain next read the annual report, and Mr. T. B. Haywood read the financial statement, both of which were as follows:—

#### REPORT OF THE COMMITTEE FOR THE YEAR 1887.

In presenting their Report the Committee have again the pleasure of congratulating the members upon the continued prosperity and increasing influence of the Society in all matters pertaining to the Rose.

Two exhibitions have, as usual, been held, one in the Royal Horticultural Society's Gardens at South Kensington, and the other in the Waverley Market, Edinburgh. The Metropolitan Show was nearly as extensive as in recent years, but the quality and size of the flowers, owing to the severe drought then prevailing, proved much below the average standard. A novel and striking feature of this Exhibition was the display of Tea Roses, which was obtained by grouping together all the exhibits shown in the classes for Teas and Noisettes only. The effect was rendered all the more striking by the fact that on this occasion there were staged a larger number of blooms in this refined and popular section than at any show previously held. In order that the Society might still further make good its claim to being really National, it was resolved that the provincial Exhibition should be held at Edinburgh in connection with the summer Show of the Royal Caledonian Horticultural Society, and the Committee feel that their thanks are due to the Lord Provost of Edinburgh and the officials of the Caledonian Society for the very hearty welcome which they extended to the members of the Society who visited this Show, and also for the liberal manner in which all the arrangements were carried out. This Exhibition proved a very interesting one, the Roses of England, Scotland, and Wales being all more or less well represented. It will thus be felt that in the matter of Roses at least the union has this year been well maintained.

The Jubilee of our Gracious Queen was naturally regarded all over the kingdom as an occasion which should be in various ways permanently commemorated. It was, therefore, considered by many of our members that the National Rose Society ought not to be behindhand in this respect, and the initiative having been taken by one of our Vice-Presidents, the Hon. and Rev. J. T. Boscawen, at the annual dinner in December, a fund was started, and with it were purchased two handsome silver-gilt challenge trophies of the value of £50 each, to be competed for annually at the provincial shows of the Society.

The first competition took place at Edinburgh, and your Committee doubt not that these competitions will, as time goes on, add materially to the interest of these provincial exhibitions. The total sum raised amounted to £112 15s., while the cost of the vases was £102 6s. 6d., thus leaving a small balance, which, as it was not large enough for any special purpose, has been added to the general funds of the Society.

The Committee have recently been engaged in collecting the opinions of the most eminent rosarians, both amateur and professional, as to what Roses should be inserted in the supplement to the Society's Catalogue of Exhibition and Garden Roses, which they propose issuing to members during the course of the ensuing year.

FINANCIAL STATEMENT.—With regard to the financial condition of the Society the Committee are happy to report that in their opinion, considering the demands made upon their members and others during this Jubilee year, it is entirely satisfactory. The amount in hand at the beginning of the year was £6 19s., and now at its close there remains £48 3s. 2d. to carry forward to the next account, the total expenditure having been £555 4s. 5d., while the aggregate receipts were £603 7s. 7d. A good many changes have, as usual, taken place in the *personnel* of the members, but the numbers still continue, as has been the case since the formation of the Society, to increase steadily. In addition to the annual subscriptions, as has before

been mentioned, a further sum exceeding £100 has been contributed by the members to the Jubilee fund.

ARRANGEMENTS FOR 1888.—The Committee have felt, in the great uncertainty which seems to hang over the Royal Horticultural Society's movements, that it would be desirable to make some other arrangements for next year. Various plans and places have been suggested to them, but most of these on investigation have proved from various causes impracticable. After due consideration, arrangements have been entered into with the Directors of the Crystal Palace to hold the Society's Metropolitan Show there on Saturday, July the 7th. The Committee, having regard to the zealous and efficient manner in which the Show at Darlington was carried out in 1882, under the care and good management of Mr. E. R. Whitwell, have arranged to hold their Provincial, or Northern Show, at that place in the coming year. The date of this fixture will be Friday, July the 20th.

MEMBERS' PRIVILEGES.—The privileges of members are the same as in former years, subscribers of £1 being entitled to two private view tickets, and also to four transferable tickets admitting at the same time as the general public. Members subscribing 10s. are entitled to one private view ticket, and also to two transferable tickets. Each one of these tickets will be available at either of the Society's exhibitions. Members who are subscribing for the first time in 1888 will receive a copy of the Society's Illustrated Catalogue of Exhibition and Garden Roses. The new supplement to this Catalogue will be issued to all members as soon as published. In conclusion, the Committee have again to express their sincere thanks to their local secretaries for the assistance given them by procuring fresh members, and also in other ways extending the influence of the Society. They wish in particular to mention Mr. R. E. West, their lately appointed local secretary for Reigate, through whose exertions an unusually large number of new subscribers have been induced to join the Society. At the present time there remain on the Society's books altogether 443 members, as against 418 in the previous year.

#### BALANCE SHEET—YEAR ENDING 30TH NOVEMBER, 1887.

1886.	RECEIPTS.	£	s.	d.
Dec. 1.	Balance at Bankers .. .. .	6	19	0
	Subscriptions received .. .. .	314	2	8
	Donations to Society .. .. .	5	0	0
	Affiliation Fees and for Medals from Affiliated Societies .. .. .	72	10	6
	From Royal Horticultural Society .. .. .	80	0	0
	From Royal Caledonian Horticultural Society .. .. .	100	0	0
	Received for Prizes .. .. .	13	0	0
	Sale of Catalogues .. .. .	0	14	11
	Balance from Jubilee Fund .. .. .	6	0	6
		<u>£603</u>	<u>7</u>	<u>7</u>

Balance .. .. . 48 3 2

EXPENDITURE.	£	s.	d.
Printing, Stationery, and Advertising .. .. .	84	0	0
Postage, Telegrams, Messengers, and Sundry Expenses .. .. .	27	8	10
Expenses, South Kensington Show .. .. .	7	19	0
Edinburgh Show .. .. .	8	10	0
Medals .. .. .	6	16	1
for Provincial Societies .. .. .	57	15	6
Prizes, South Kensington Show .. .. .	247	0	0
Edinburgh Show .. .. .	145	15	0
Assistant Secretary and Accountant .. .. .	20	0	0
Balance at Bankers .. .. .	48	3	2
	<u>£603</u>	<u>7</u>	<u>7</u>

#### JUBILEE FUND.

RECEIPTS.	£	s.	d.
Subscriptions received .. .. .	112	15	0
	<u>£112</u>	<u>15</u>	<u>0</u>
EXPENDITURE.	£	s.	d.
Elkington & Co. .. .. .	102	6	6
Printing, Stationery, and Postage .. .. .	4	8	0
Balance carried to general account .. .. .	6	0	6
	<u>£112</u>	<u>15</u>	<u>0</u>

THOMAS BURT HAYWOOD, Hon. Treasurer.

Audited and found correct,

FRAS. TULLIE WOLLASTON } Auditors.  
J. D. PAWLE }

Several resolutions were then proposed and adopted without discussion, as, for example, that the report and financial statement be printed and circulated; also votes of thanks to the Horticultural Club for the use of their rooms during the season, and to the officers and Committee of the National Rose Society for their services during the year. It was then proposed by the Rev. J. H. Pemberton, and seconded by Mr. G. Bunyard, that the following addition be made to Bylaw 12, "No medal sent without prepayment." It was stated in explanation of this addition that considerable delay had occurred in some cases in the payment for medals, and it was thought that prepayment would save the Treasurer and Secretaries some trouble. The matter was fully discussed, several being in favour of modifying the clause to be inserted, but the original proposition was ultimately agreed to. The Chairman then announced the following to have been duly elected as Committee and officers for 1888:—President, the Very Rev. Dean Hole; Vice-Presidents, the Hon. and Rev. J. T. Boscawen, Rev. J. M. Fuller, Robert Hogg, LL.D., and James McIntosh; Hon. Treasurer, Thomas Burt Haywood; Hon. Secretaries, Rev. H. Honeywood D'Ombrain and Edward Mawley; General Committee, H. Appleby, J. Bateman, Rev. H. A. Berners, R. Bloxam, G. Bunyard, Rev. F. R. Burnside, J. Burrell, B. R. Cant, F. Cant, Rev. A. Cheales, Captain Christy, W. F. Cooling, J. Cranston, Rev. A. Foster-Melliard, Rev. F. H. Gall, T. W. Girdlestone, W. J. Grant, T. B. Hall, R. Harkness, G. P.



Hawtrey, J. Shirley Hibberd, C. F. Hore, W. J. Jefferies, E. B. Lindsell, M. T. Masters, F.R.S., Rev. F. Page-Roberts, G. Paul, J. D. Pawle, Rev. J. H. Pemberton, G. W. Piper, A. Prince, W. Rumsey, J. Sargant, A. Slaught, A. Turner, R. E. West, E. R. Whitwell, E. Wilkins, Rev. W. Wilks, and W. H. Williams; Hon. Auditors, J. D. Pawle and F. T. Wollaston.

In regard to the provincial Exhibition of 1889 it was decided that the Hon. Sec., the Rev. H. H. D'Ombraim, should be instructed to write to the officials of the Horticultural Society in Dublin with a view to holding the Exhibition in that city, and the opinion of the meeting was strongly in favour of such a course. A vote of thanks to the Chairman, proposed by Mr. G. Paul, and seconded by the Rev. A. Foster-Melliard, brought the business to a conclusion, but a meeting of Secretaries of affiliated Societies was subsequently held to endeavour to arrange the dates of the shows next year to avoid clashing as far as possible.

At 6 P.M. the annual dinner was held in the same Hotel, the Hon. and Rev. J. T. Boscawen presiding, and there was a good attendance of members.

### HYBRIDISING AND CROSS FERTILISATION.

THE Society of American Florists held their third annual convention at Chicago on August 16th, 17th, and 18th of the present year, and it has been previously noted that the meeting was a very successful one. A volume devoted to the full report of their proceedings on this occasion has recently come to hand, from which we extract the following as of general interest.

Mr. John Thorpe of New York, after a cordial welcome, read a paper as follows—This subject has from time to time during the present century been so elaborately treated by such men as Darwin, Müller, Delpin, Hildebrand, as scientists, on one hand, and by Laing, Lemoine, and Bennett, as practical men on the other, that I feel it is one I know scarcely anything about. My experience, though of much interest personally, is of such limited extent as to make me feel as though I have no right in the field; yet, some of my labours, contracted as they have been, may be of some service to those who are desirous of becoming producers of new varieties of plants by hybridising and cross fertilisation, if made known.

The term "hybrid" has been so generally wrongfully used, it is well for me to say that there are no hybrids except they are the offspring of different species, as, for example, a seedling raised from seed of the well-known Gen. Grant (Pelargonium) Geranium as one parent, and Master Christine as the other, would not be a hybrid, but simply the result of cross fertilisation. But if a seedling could be obtained from Gen. Grant and the Rose-scented Pelargonium graveolens, then we should have a true hybrid. At the same time, we must not forget that many of the most interesting groups of plants now cultivated were originally hybrids of species; this is notably so in the Tuberous Begonias. The foundation of this superb class being boliviensis, Pearcei, Davisii, Octopetala, admitted by botanists to be species, but the varieties in these groups today can be no longer hybrids, through their having been crossed repeatedly with one another. It must be borne in mind, however, that there is yet to be seen the influence of the original parentage in the different groups. For instance, the yellow varieties still retain the marbled leaves and dwarf habit of Pearcei, the orange-scarlet has the long leaves and branching growth of boliviensis, the deep crimson has the hairy and thick leathery leaves of Davisii, and so through each group there is a sort of ear-mark not to be obliterated. The same applies to Pelargoniums, to Carnations, to Chrysanthemums, to Roses, and, indeed, to all cross-bred seedlings.

Among the few plants I have been interested in and experimented with are the Zonal Pelargoniums, perpetual flowering Carnations, and Chrysanthemums. Of the former I have raised seedlings by cross fertilisation for nearly thirty years, and during that period I have had the pleasure of seeing them brought from comparative obscurity to the position they now occupy. The many colours to be found in them at this time have been obtained one by one from a very few, as may be remembered by those who know how limited, not only the colours, but the varieties were at the time above mentioned.

I have found that to be successful in raising seedlings it is necessary to have patience, perseverance, and good judgment—to lay down your standard of perfection and what is wished to be obtained, and then work for it. One of the first things is to secure a good set of plants, possessing collectively the properties most desirable, then to mate them accordingly, being careful to prevent their being fertilised by insects or otherwise, so as to be sure of your own work being accomplished. The best time of the year to cross Pelargoniums I have found to be early in November, as at that season there are but few insects to interfere, the atmosphere is not as buoyant, consequently the pollen grains do not float in the air as they do during the summer months, so that there is a greater certainty of making the cross positive. I find since making November the seed month the results are more satisfactory, for instead of having to raise thousands to get a dozen improvements, as where the breeding was done in summer, only a few hundred need now be raised.

For some years I have not used any varieties as parents except my own seedlings; as I found by the constant bringing in of varieties raised by others, I frequently have broken up the characteristics I was anxious to perpetuate. This is entirely at variance with what has been written on the subject of cross fertilisation where the introduction of new blood is always recommended as being absolutely necessary; but we have

only to consider how the best stocks of vegetables and flower seeds are preserved, and how the best breeds of horses, cattle, and dogs are maintained. It is certainly not by introducing foreign blood; on the contrary, it is by keeping stocks of seeds, and families of animals, away from the influence of strangers.

The crossing of varieties to obtain particular colours is another matter which has been of great interest to me, as I have found as a rule where I have used a scarlet variety as one parent and a white one as the other, the result has not been as satisfactory as where I have used parents the colour of which have not been so widely separated, as there are always variations in seedlings, many of which differ greatly from either parent. If a seedling shows any new character it is decidedly the best thing to keep it intact for at least two generations, and to breed it in-and-in so as to establish its peculiarities. This not only applies to Pelargoniums, but to cross-bred plants generally.

In raising seedling Carnations for winter flowering it will be necessary to use for parents such varieties as have the tendency to flower early, combined with a strong free habit of growth, as I find a large majority of the seedlings do not flower as early and prolifically as their parents, many of which will give but one crop of flowers in early summer. These I find are also much easier to cross in the winter months than at any other season. As with Pelargoniums so with these: I would advise laying a foundation of your own, and using those for parents having the most desirable properties.

How far nature yields to man's influence is well portrayed in the Carnation. When this, by different raisers, was taken in hand to improve it, there were but few free-flowering varieties; there were scarcely any with long stems, and most of them had split calyx. In the early days of Carnations there was no choice, now we can afford to be critical, and this in the short space of twenty years. I hope to live to see the Carnation as it will be twenty years from now.

Artificial fertilisation of Chrysanthemums has not been carried out to any great extent until recently. It is an operation requiring greater care in manipulation than either the Pelargonium or Carnation. Select the variety you wish to be the seed parent (plants in 6 or 7-inch pots preferred with one or two flowers on each), then, as the flowers open, with a pair of sharp scissors, cut off the petals so as to expose the styles at their base; cover over with a piece of fine netting to prevent premature fertilisation. Select for your pollen, or male parent, one which has the desired properties you wish to combine with the seed parent, then as the pollen ripens apply it to the style with a fine camel's-hair brush or a fine feather. Chrysanthemum seed ripens in from three weeks to a month.

The mechanical part of cross-breeding I need scarcely mention, except to say that it is important and absolutely necessary to remove the stamens from all flowers before there is a possibility of their becoming self-fertilised, and to protect them from being crossed other than by the variety selected by the operator. The new varieties may be better than the older ones, if only from their having more vigour and stronger constitutions.

(To be continued).

### THE LIVERPOOL HORTICULTURAL ASSOCIATION.

It is questionable if greater number of horticulturists could be gathered together from the neighbourhood of any provincial town than assembled in Liverpool on Saturday evening the 10th inst. The first annual gathering that the Society has had was a splendid success, and it is to be hoped that a social meeting of this description will be held yearly. Many less influential societies have their annual dinner, and Liverpool would do well to follow their example. It is only on such occasions that the members have an opportunity of meeting together mutually to strengthen that good feeling that should exist between the various branches of horticulture, and thus unmistakably consolidate the institution. The Liverpool Horticultural Association was the outcome of a very small meeting held nearly nine years ago by Messrs. J. Bramham, W. Tunnington, W. Blomily, W. Mease, and W. Bardney. It must be gratifying to them, as well as to all concerned, that the Association has made such great progress as to be financially and otherwise in such a strong position.

But turning to the proceedings of the evening, it must be stated 120 persons attended. Fletcher Rogers, Esq., Woodend, Grassendale, the Hon. Treasurer of the Society, took the chair, supported by Mr. White and Mr. Richardson, the Chairman and Ex-Chairman of the Association. After the Queen and Royal Family had been befittingly honoured the Chairman proposed the toast of the evening, "The Liverpool Horticultural Association," to which Mr. White very ably and suitably replied. Next came "The Press," to which Mr. W. Bardney responded. The toast of the "Horticultural Trade" was responded to by Mr. R. W. Kerr and Mr. T. Davies, the former unquestionably making the speech of the evening, ably urging the claims of the Association and appealing to the Chairman, Mr. Fletcher Rogers, who he said could, and he knew would, bring the Association before those ladies and gentlemen of the neighbourhood who had as yet not subscribed to the funds, to contribute one guinea or more and add it to their garden expenditure. The toast "The Hon. Treasurer," followed, to which Mr. Fletcher Rogers responded, and he bore testimony to the excellent manner in which the Society was managed, and he assured all present that the finances were conducted on as satisfactory a basis as those of any commercial business in the city. Mr. Richardson proposed the health of those who had so largely contributed to the dinner by giving plants, fruits, &c., to which

Mr. A. R. Cox replied. The health of Mr. White, Chairman of the Association, and Mr. E. Bridge, Secretary, brought a very enjoyable evening to a close.

### CHRYSANTHEMUM NOTES.

#### NATIONAL CHRYSANTHEMUM SOCIETY.

THE annual dinner of this Society was held at Anderton's Hotel, Fleet Street, at 6.30 P.M. on Tuesday, December the 13th, and proved a remarkably successful gathering, about 100 members and friends being present. The President, E. Sanderson, Esq., was in the chair, and was supported by Sir Guyer Hunter, M.P., the Treasurer, J. R. Starling, Esq., and several other gentlemen; the Vice-President, R. Ballantine, Esq., and the Hon. Secretary, Mr. Wm. Holmes being also present. The usual loyal and patriotic toasts were proposed and duly honoured, and numbers of other toasts were proposed and responded to in very appropriate speeches. An excellent selection of songs diversified the proceedings.

In the course of the evening the surprising progress the Society has made in the past few years was frequently alluded to, and Mr. Holmes stated that the number of members is now nearly 500, showing an increase within the past year of 145, and it is estimated that the total income of the Society by the time of annual meeting will be fully £700. It was also announced that the whole of the prize money awarded at the November Show—about £300—had been paid to the winners, and on this occasion the silver cup (won by the President) with the silver and bronze medals were presented to the winners, Mr. G. Stevens of Putney having won four medals and £19 in money. It was pointed out that the Society had done much good work, and it was evident from the support they had received that their efforts were appreciated by amateur and professional floriculturists, but there is still abundant scope for greater efforts, and the coming year will bring much useful work for the Society and its Committees to perform.

The prize fund for the ensuing season was opened, and it was announced towards the close of the meeting that £45 had been promised or paid. It may also be added that there are now thirty provincial Societies affiliated to the National, including one at Melbourne, Australia.

#### RIVAL CHRYSANTHEMUM SHOWS.

A SPIRIT of rivalry, when conducted upon proper lines and within certain limits, is generally admitted to be beneficial; but when the rivalry exists between those who should be united as members of one family—as they are members of one household—then the results are very liable to be disastrous to one or both parties. In Sheffield two Chrysanthemum exhibitions are now annually held, exclusive of small but highly creditable shows got up by workmen in different parts of the town. There ought only to be one representative exhibition. The exhibition held annually by the Sheffield and Hallamshire Gardeners' Mutual Improvement Society has the right of priority; but until this year I believe that exhibition, in regard to exhibitors, was confined to members of that Mutual Improvement Society. The Sheffield and West Riding Chrysanthemum Society was formed three or four years ago for the purpose of establishing an exhibition wherein all classes of the community might compete, whether they were members of the Society or not. The latter Society is composed of amateurs, gardeners, and cottagers; the former is composed chiefly of gardeners. Each Society receives considerable support from numerous patrons, and both of them have this year held most successful exhibitions floriculturally. That of the Mutual Improvement Society far surpassed in general quality any of its previous exhibitions that I have seen, and the Committee are to be congratulated upon the success of their efforts to improve the quality of their exhibits. Several groups of Chrysanthemums would have occupied honourable positions at either the Aquarium or Kingston-on-Thames, places noted for the quality of their Chrysanthemums. Primulas, as a rule, are not shown better anywhere than they are annually at this exhibition.

The exhibition of the Sheffield and West Riding Chrysanthemum Society was very strong in cut blooms. Classes and competitors were very numerous, and the Judges in that section had two or three hours' hard work. Specimen plants were well shown by one or two exhibitors; but one or two exhibitors cannot make a large show unless they happen to be what are termed "big growers," which they were in this instance. A deficiency of specimen plants or of groups of plants always causes an exhibition to look weak, especially so in very large rooms. In Sheffield there is sufficient material to make a Chrysanthemum exhibition second to none in the kingdom, if the growers will all unite. Divided, both cannot hope to occupy such a position except by a very lavish expenditure of money, and I fear the receipts would not justify such an expenditure in both cases. Why cannot both Societies meet on common ground and hold one exhibition? I believe I am correct in saying that about nine-tenths of the members of the Sheffield and West Riding Chrysanthemum Society are desirous of such a course. I also understand that some of the members of the Sheffield and Hallamshire Mutual Improvement Society are equally in favour of the proposal. If such is the case, surely there can be no insurmountable obstacle in the way. Concession on one or both sides appears to be the remedy. To yield in such a case is far more honourable, truly dignified, and courageous than to be unyielding. It is admitted on all hands and by all who are disinterested, that the aspect of two such Societies in one town being in conflict upon such a matter is deplorable.—J. UDALÉ, *Elford*.

#### A REPRESENTATIVE CHRYSANTHEMUM CLASS.

AT most the leading Rose Shows classes are provided for seventy-two blooms. Why cannot something of the same kind be provided in the case of Chrysanthemums? It is conceivable that representative collections comprising this number of blooms could be provided more easily than showing forty-eight blooms in two sections alone. In order to bring the class within the means of the greatest number of growers the conditions should be as little exacting as possible, and the more easily they could be complied with the better the aggregate display both as regards the merit of the stands and the number of competitors. As a suggestion for the consideration of those who may think good to take notice of it, the following proposition is advanced as the framework, open to improvement, of what might constitute a very fine and highly interesting class:—Twelve incurved blooms, distinct; twelve Japanese blooms, distinct; twelve reflexed in eight varieties; twelve large Anemones, four to be Japanese; twelve Pompons, six to be Anemones; twelve singles in six varieties. The two last stands to be arranged with three blooms (not more) of each variety, with stems and foliage not less than 4 inches above the board.

Six stands of the nature suggested would be much more easily furnished than would four large stands of twenty-four incurved and the same number of Japanese, would be as easily conveyed to a show, and would be even more interesting. If a gold watch were offered for a first prize, the winner's name to be inscribed thereon (or £10, at his option), with three other prizes of £7, £5, and £3, good competition might be expected, and a diversified and effective display produced. Such a class ought to be popular with exhibitors, and the representative exhibits could scarcely fail to attract the attention of visitors to shows. Perhaps readers who are interested in Chrysanthemum growing and showing may say something for or against the proposition. If it will not stand the test of public criticism the idea can be abandoned, and no harm will be done by its advancement.—M. N. C. S.

#### CLASS CARDS AT EXHIBITIONS.

I NOTICED at the Hull Chrysanthemum Society's Show a capital system of arranging the class cards for the guidance of exhibitors, and one that might with advantage be imitated by a large number of societies. Large cards, similar to prize cards, only perfectly plain, with "Class 1," "Class 2," and so on for every class in the schedule, printed on them in large letters and elevated on a neat stake in the centre of the stage, denoting the exact position where the exhibits in that particular class were to be arranged. These cards would do for years if taken care of, and they save endless confusion to exhibitors, stagers, as well as reporters, who can see at a glance to what class any particular exhibits belong. These cards are far in advance of the old chalk lines, and save the labour of going with each exhibitor to show him where to place his exhibits. This system would only entail the outlay of a few shillings, and would prove advantageous if adopted by all large Societies, such as Liverpool and others.—R.

#### CHALLENGE VASES.

IN the last paragraph of Mr. Molyneux's article, page 465, he applauds on one hand the various societies who have offered challenge trophies to be the property of those who win them two or more years in succession, while, on the other hand, in the interest of exhibitors he gently rebukes them. No doubt the paragraph has been written on purpose to draw from others their views on this subject; if not, his testimony is a little conflicting. If challenge vases render societies popular, and are unpopular with exhibitors, what must eventually be the result? To my mind merely offering large trophies, such as have been given at Kingston, Hull, and Liverpool—the latter may be included, although the cup given on these principles was slightly less valuable—during the past few years, may, and do unquestionably bring such societies before the public. In a sense this may render them popular, but how long would they retain their popularity without the aid of exhibitors? The latter are attracted to those shows that offer the greatest advantages, but have exhibitors appeared in such large numbers to compete for these vases as would justify societies offering them in the future on the same principles? I do not think they have. At Liverpool the competition has been keener and better for the valuable prizes given annually by Messrs. Williams & Co. than was the case when given to be the property of those who won it for two consecutive years, or a certain number of times in all. This year 192 blooms were staged for the silver tea and coffee service given by these gentlemen, and £3 by the society. This is now given, and has been for some years, without the slightest restriction, in fact no more so than the money prizes given by the society.

At Hull only three collections were staged in the principal class for the challenge cup, which alone shows that these trophies are by no means looked upon with favour by exhibitors. In addition to the eup valuable money prizes were given as well—namely, £15, £10, and £5 respectively for the winner of the vase and the second and third prize. These alone, independent of the vase, should have drawn a better competition. The Committee of the Hull Society have certainly set a noble and generous example in giving such good prizes as well as the cup. If competitors can be induced to compete for challenge vases to be won two years in succession, it is only by such action that they can be rendered a success. The money prizes must alone be worth going for. I was pleased to see that the Hull Society had taken this line of action. They are certainly doing what they can to bring their Society into prominence and render their exhibition one of the best in the country



Even such liberal prizes did not induce exhibitors to enter the competition. Why was this? In my opinion the reason is perhaps, because, when it is known that two or three of the leading growers are, or have entered, others that are rather doubtful of their success against these growers are certainly deterred from doing so. Secondly, because the strain upon the exhibitor is intensified tenfold, especially if he succeeds in winning the cup. This is even more marked when the cup is given to be the property of the employer and not the gardener. This touches the third reason, and gardeners will not enter freely when they know that if they win the cup it is not for them. The money prizes when large enough may draw them, but they do not willingly toil early and late in order to compete for prizes that they know at the outset will not really reward them for so doing. It must not be overlooked that extra care, labour, and anxiety are imposed upon gardeners and their assistants by exhibiting, and they are worthy of all they can win. Although, legally no doubt, whatever they win is the property of the employers, they rarely claim it or expect it, but willingly allow their gardeners to exhibit and have what they can win. The employers are amply rewarded, for the gardener works with greater willingness and determination to succeed, and consequently the produce generally in the garden is better than would be in the majority of cases if they were not stimulated by the chance of winning a few prizes. I wonder how many they would attempt to win if they were to reap no advantage by so doing? This may certainly seem like selfishness on the part of gardeners, but it is not really the case. They look with suspicion on "challenge vases" given to be the property of the employer, for such action may foster a desire to make a claim for all cups, medals, &c., that are won by the gardener. I have known ill-feeling created by this cause, and the gardener gave up his place in consequence, as also did his successor. Whether they were wise in such a course is no part of my business to discuss. But if societies are to fulfil the object for which they exist it is the duty of those who manage them not to offer prizes that probably will lead to mischievous results.

I may be referred to the competition at Sheffield, and told that it was no better than at Hull, although the cup they gave was without the slightest restrictions and became the property of those who won it the first year. Nine competitors entered, and it was certainly unfortunate that only three of that number turned up. No doubt Birmingham, Hull, and other Shows being held so close together may have had much to do with this, and it must be remembered that there was a show in Sheffield only the week before.

I know that it is contended that these challenge vases are given as an inducement to employers to allow their gardeners to compete. I do not see that this has had the slightest effect whatever, for those who have competed for them in every case were allowed to exhibit before they were offered. There may be a solitary exception, but it is not known to me. I think if cups were offered the same as the money prizes, to be competed for and won in one year, the number of exhibitors would be increased considerably. This would be more likely to render shows "popular in the main with the public as well as the exhibitors." The object should be to gain as many exhibits as possible for the prizes offered. The more that take part in the show the more popular it is likely to become, and it will insure the shows being good and improve annually. Valuable prizes given on the principle of those at Kingston and Hull bring at the most probably not more than two competitors, and I maintain that this is not as it should be. Liverpool has never offered more than a ten-guinea cup and £3 for the first prize, but the classes in many cases are protected so as to give small as well as large growers a chance, and the result has been one of the best autumn Shows in the country.—WM. BARDNEY.

#### ECCLES, PATRICROFT, AND PENDLETON CHRYSANTHEMUM SHOW.

THE first annual Exhibition was held under the auspices of the Patricroft Linnean Botanical Society at the Eccles Town Hall on Friday and Saturday, the 25th and 26th November. The Hall was well filled and presented an attractive appearance, and the Committee are to be congratulated upon the excellent exhibits of both plants and cut blooms. For Chrysanthemums in pots the principal first honours were won by G. N. Leigh, Esq., Swinton (Mr. T. Balshaw, gardener), whose plants would have been hard to surpass at any show; J. Stock, Esq., Eccles (Mr. G. Barlow, gardener); Mr. W. Russell, nurseryman, Swinton; Mr. James Smethurst, Winton; and Mr. R. Johnson, Barton. For cut blooms, Japanese, the following are the first-prizewinners:—Mr. John Walker, Stockport, and T. Dickens, Esq., Higher Broughton (Mr. H. Bennell, gardener); Mr. Peter Eckerley, Middle Hutton; Mr. J. Royle, Swinton; and R. Johnson, Barton. For incurved cut blooms the first prizes were won by T. Dickens, Esq. (Mr. H. Bennell, gardener); Messrs. P. Eckersley, Middle Hutton; W. Eckersley, Middle Hutton; and R. Johnson, Barton. For six table decorative plants the first prize was awarded to J. Stocks, Esq., Eccles; for six pots Roman Hyacinths to H. Dickens, Esq., Higher Broughton; and for six pots Poinsettias to W. Agnew, Esq., Pendleton (Mr. J. Bradley, gardener).

A splendid collection of Palms and other decorative plants was lent by Mrs. T. Agnew, Eccles; W. Agnew, Esq., Pendleton; and Stuart Garnett, Esq., Pendleton. Messrs. W. Clibran & Son, Altrincham, exhibited, not for competition, a stand of nine dozen of each of Japanese and incurved blooms, which were much admired. They had also a separate staging for decorative plants, bouquets, wreaths, and sprays. Messrs. Dickson & Robinson of Manchester displayed a first-class selection of Cyclamens, Celosias, and other plants in pots; and Messrs.

Dickson, Brown, & Tait of Manchester showed a splendid collection of Cyclamens, Ferns, and Ericas. Messrs. W. Lovell & Sons of Winton sent a good selection of table decorative plants and Chrysanthemums in pots; and Mr. W. Russell of Swinton was well represented by a good display of Pompon Chrysanthemums in pots, and bouquets, wreaths, &c. A splendid collection of Apples, grown by the exhibitor, Mr. James Derbyshire, Liverpool Road, Patricroft, was also staged in the Hall, and was much admired. The Judges were—Messrs. T. Cash, Prestwick; J. Kertin, Altrincham; J. J. Lowry, The Garden, Trafford Hall, Barton. The attendance was much above expectation, and the Committee feel encouraged by the generous support accorded to them.

#### JUDGING BY BALLOT.

A SIMILAR record of judging by ballot to the one submitted to you was also forwarded to me, and after studying and perplexing myself over it for a considerable time I threw it away disappointed, though afterwards I thought the reason of my not understanding it might be attributed to my obtuseness. Your observations on the subject have, however, satisfied me that such was not so.

The way "how not to do it" was never better exemplified than by this example at the N.C.S. Show. When the method was first mentioned to me, I inquired why three men were not sufficient to adjudicate, because if three were not enough thirty would not be too many, and if eighteen were necessary, why stop at eighteen? and why not have eighty? But no; it was to be eighteen experts. Experts indeed! It was amusing to watch at least one of these experts, who displayed a decided flush of enthusiasm on receiving his ballot ticket. He was loud on the intrinsic qualities of the most overblown flower in the competition, thereby displaying a perspicuity of intelligence that none but "an expert" could command. Add to this the suspense and desire of the public to know the awards, which were delayed from 11 A.M. till 6 P.M., and I think most exhibitors will exclaim, "Save us from the ballot." It may answer the purpose of the promoter to keep up the sensational excitement brought by such a means, but I trust never to see our worthy President mixed up with such a farce, or the N.C.S. ever again be the medium of its being enacted.—BRONZE PETER.

#### CHRYSANTHEMUM AMY FURZE.

On page 499 "A Judge" considers this variety should only be shown as a reflexed flower when in a young state. This seems to me a most unsatisfactory arrangement, and likely to lead to much misunderstanding, and not a little heartburning among exhibitors, unless, indeed, it were possible to instil into all judges and exhibitors alike the principle here laid down.

The case seems to require one of two radical measures—either confirm Amy Furze as a reflexed, in which case each flower exhibited should be judged on its own merits and not subjected to "be either passed or lose points" when perfectly developed; or it should be relegated to the Japanese class. Seeing that good reflexed flowers are comparatively scarce, would it not be advisable for the National Chrysanthemum Society to consider the advisability of a reclassification, when possibly such varieties as Elaine and Dr. Macary may be transferred from the Japanese class to the reflexed. I quite agree with "A Judge" as to the excellence of Amy Furze as a decorative variety; it comes good on any bud, and if not disbudded has the commendable habit of throwing an abundance of small perfectly formed side flowers.—T. W.

#### CHRYSANTHEMUMS AT ASHTON HALL, LANCASTER.

IN Lancashire, where this popular flower is so well cultivated, there are very few plants which have been grown to greater perfection this year than the collection displayed in the gardens of the fine old residence of J. P. C. Starkie, Esq., J.P. Although it is only recently that Chrysanthemum growing received much attention here, unless for ordinary use, yet at the time of my visit last month the collection was the centre of attraction to many who received a hearty welcome from the owner. The blooms were far beyond anything I expected to see in this far northern division of Lancashire, and, judging from the position they held on the exhibition tables at Huddersfield and Sheffield Shows, where they were in competition with some of the Liverpool champion growers, they are likely to be heard of again. The plants, which were most effectively grouped, occupied a large house, ranged in height from 5 to 10 feet, and the blooms, many of them measuring from 8 to 10 inches in diameter, reflected great credit on Mr. Hargreaves, the head gardener, whose perseverance is recognised by his worthy employer.—VISITOR.

#### ALNWICK SHOW.

The Alnwick Horticultural Society held a Chrysanthemum Show on Thursday, December 8th, in the Corn Exchange. The variety and excellence of the display gratified a numerous company, who failed not to avail themselves of the novel and interesting sight, while the promoters of this new venture have cause for satisfaction at the success of the project. It was at the last annual December meeting the proposition to hold a Chrysanthemum Show was brought before the members by Mr. D. P. Bell, an energetic local horticulturist and florist, and by them cordially agreed to. The fact of no similar show being held in the county evidences a spirit of enterprise on the part of the Committee, and has had the effect of awakening a healthy rivalry quite beyond the limits of the locality.

The spacious hall of the Corn Exchange on Thursday presented an exceeding pretty aspect, every possible variety of the popular Chrysanthemum being shown. Near the centre of the room stood a handsome pyramid consisting principally of Azaleas, Bouvardias, and foliage plants,



the judicious arrangement of which was due to the efforts of the highly respected head gardener at the Castle, Mr. G. Harris, who has spared no pains and trouble in his endeavours to add beauty and variety to the non-competitive portion of the exhibits. At the south end of the hall a number of Orange plants—also from the Castle Gardens—were exhibited. Other exhibits not for competition included a number of Chrysanthemums of the variety Ralph Broeklebank, and for which Mr. Thomas Winkworth, gardener to Mr. Ralph Broeklebank, of Child-wall Hall, Liverpool, was awarded a first-class certificate; a fine collection of Apples and Pears from Mr. R. Henderson, of Chillingham Castle; baskets of Tomatoes in excellent condition from Mr. J. Thompson, Shawdon, and Mr. D. P. Bell, Alnwick; a few well developed Brussels Sprouts from Mr. J. Oliver, Eslington Park; and some large Leeks and heads of Celery from Messrs. T. White, and G. Loekey, Alnwick. The exhibits were arranged on tables placed along the sides and centre of the hall. As was anticipated, the Chrysanthemum secured a large competition the chief prizetakers being Mr. Paul Blanshard, Jesmond, and Mr. D. P. Bell, Alnwick. Prizes were also awarded for fruit, Mr. D. P. Bell carrying off first honours for Grapes, Mr. D. Inglis, Howick, for fruit and Pears. Cut flowers also entered into the competition, Mr. Bollom, Axwell Park, being most successful in this department. The Judges for pot plants and cut flowers were Messrs. T. B. Morton, Darlington, and R. Thompson, Felton Park; and for the miscellaneous exhibits Messrs. G. Harris, Castle Gardens, and D. Inglis, Howick. The duties of Secretary were ably performed by Messrs. G. Simpson, J. Ferguson and W. Robertson. In the evening the Show was crowded to excess.

#### CHALLENGE CUPS.

I CAN assure Mr. Jameson, in reply to his "last" note, that the only "feelings" of mine he has yet reached are those which are identified with the humorous part of my nature; and my previous note was penned for the purpose of showing that it was impossible for him to be aware of the exact amount of my knowledge of the subject discussed. Doubtless Mr. Jameson's motive for suggesting a clause enabling executors to continue a competition was good, but it has to be remembered, in the case of the death of an employer, there are scarcely any executors who would carry on the gardens and allow the necessary time and money required to grow Chrysanthemum flowers for the purpose, and on the chance of winning a cup. That being so, Mr. Jameson's clause is a "dead letter," and my proposition remains in effect.

It is a singular fact that out of between fifty and sixty Chrysanthemum exhibitions held this season there appears to be only three or four at which the challenge cups or vases are offered. The Liverpool people do not offer one, and I think that is the best Chrysanthemum show in the country. The National Chrysanthemum Society does not, nor Birmingham, York, Lincoln, Sheffield and West Riding, or Huddersfield, and probably others that I have not seen are equally as good. If about 90 per cent. of good shows are obtained without offering challenge vases, I think the remaining 10 per cent. could get up equally as good displays without recourse to them. I have always thought that challenge vases, when offered for individual competition, were valuable objects misapplied. Nothing that I have yet heard, seen, or read has altered my views on that matter. I do not expect everyone else to agree with me, and least of all do I expect any member of those Committees who offer them, nor yet all the exhibitors who have won such cups or vases; but I believe the majority of those exhibitors are tired of the system.

Mr. Jameson appears desirous of encouraging employers of gardeners to take a greater pleasure and interest in exhibitions; that is a very laudable desire. The question arises, How shall that object be best attained, and involving the minimum of individual disappointment combined with the maximum amount of true pleasure and most enduring interest? I suggest that competitions between town and town or county and county be arranged; challenge vases to be offered by committees in such towns or counties. The exhibits to be of a specified number of flowers of any kind or kinds of Chrysanthemums, the same to be obtained from any gardens within a certain radius of a town, or the boundary of a county, and with the consent of the owner as well as gardener. Large numbers of gentlemen who now object to their green-houses being denuded of all their best flowers for exhibition purposes, would have great pleasure in giving two or three or more of his best for a town or county competition, and he would feel all pride and pleasure of a soldier in a victorious army, if his town or his county won; whilst, if they lost, he would not feel the chagrin of a losing individual competitor; but, like the soldier in the conquered army, could say—right or wrong—"it was all through those other fellows." Perhaps this proposal is not very practicable. I know there are some objections, though not insurmountable, but I will leave them for others to point out. If any Chrysanthemum Society can see their way to carry this suggestion into practice, I think they would achieve such popularity as has not yet been attained. It may be objected, Why Chrysanthemum tournaments and not "Rose tournaments," or "Cabbage Fights?" I reply, Why, indeed? Most people are weary of the monotony of our ordinary flower shows. Chrysanthemum shows bid fair to fall into the same grooves, but as they are yet a comparatively new institution something may perhaps be done to save them from coming to such a miserable fate as the others.—J. UDALE.

#### JUDGING.

I HAVE read with very great pleasure Mr. Wright's article on the science of Chrysanthemum judging in your issue of 8th inst. As a Chrysanthemum grower for nearly twenty years I consider it to be

a most valuable contribution to Chrysanthemum literature. Many growers, although believing the decision of judges should be final, take an interest in revising their decisions in close competitions. I was present at the Hull Show last year, and as soon as I heard that a protest had been entered in respect of the award referred to by Mr. Wright, I went to have another look at the two competitive stands. The losing stand appeared by general comparison to have the advantage, but on carefully pointing up the blooms after a similar system to that indicated in Mr. Wright's article, my conclusions confirm the decision of the judges. The winning stand gained more in symmetry, solidity, and freshness than it lost in size and depth—the two points which first strike an observer. Had the Show been held a week sooner the verdict of the judges would probably have been reversed. If some such system of pointing had been used by the judges at the recent Chrysanthemum Show at Manchester, we should not, I fancy, have seen six equal prizes given, as referred to by your correspondent last week. No other system can be satisfactory in close competitions. I hope Mr. Wright will not think of leaving the ranks of the judges for some time to come.—YORKSHIRE GROWER.



#### HARDY FRUIT GARDEN.

**MANURE FOR FRUIT TREES.**—It is a curious fact that the vegetable quarters frequently get more manure than is good for them, while the fruit trees do not have nearly enough. Market growers never neglect their fruit trees and bushes, those in full bearing receiving annual, or at least bi-ennial dressings of much better manure than most private gardeners can procure, and the superior crops of fruit well repay for the extra outlay. It is the long established trees and bushes in full bearing order that require assistance at the roots; those planted in fresh rich soil, and which grow too rankly, not needing any—are better without it in fact. In very many instances the wall borders are raised much higher than the rest of the garden, and old trees rooting in these not only suffer from poverty at the roots, but not unfrequently rarely get enough moisture at any time of the year. We have seen Peach, Apricot, Plum, and Pear trees much improved by having first the surface roots bared, then giving a good soaking of liquid manure from a farmyard, followed by a liberal dressing of half-decayed manure, this being enclosed by the surface soil. Thus treated at this time of year, they break strongly in the spring, the bloom being stronger and more perfectly formed, the natural consequence being a good set of better formed fruit. During the summer and autumn the trees are much less liable to suffer from drought, and the fruit will be found of a better quality than heretofore. Many a fine old Pear tree both against walls and in the open fully deserves a tub or tubs of strong liquid manure and a good load of juicy manure. Orchard trees may well have a soaking of liquid manure at once and more during the winter, as well a liberal surfacing of solid manure, and it is very certain well established Raspberry, Strawberry, Gooseberry and Currant plantations need plenty of manure, these all being hungry surface-rooting plants. The finest samples of fruit are produced by the manured trees, and in some seasons it is only the best that will sell well. Advantage should be taken of the first frost to wheel out a good quantity of manure among the bushes, or enough to just cover the ground about them, and this we would very lightly fork-in in preference to leaving it in the form of a surface mulching. We have tried both plans, and find that the manure is most efficacious when just covered with soil, it being the more accessible to the roots and less liable to dry up by winds and sunshine. Deep digging among fruit quarters generally is most injurious, but if the manure and weeds are lightly forked-in no harm results. All wall trees should have a clear border not less than 5 feet in width. As a rule the border is closely cropped nearly up to the wall, the cultivation necessary as well as the impoverishing vegetable crops inevitably driving the roots of the trees into the cold subsoil. The mistake is made in the first instance of having the borders so narrow, the temptation to crop them being irresistible.

**PRUNING CHERRIES AND PLUMS.**—Although widely differing in their character, these yet require very similar treatment as far as pruning and training is concerned. The fruit in both cases is produced on the old spurs formed by shortening back the breastwood or lateral growth on the main branches. In the case of wall trees lay in the leading branches wherever there is space yet to be filled to their full length, and according as the fan-shaped trees spread a few well placed laterals ought also to be laid in, the aim being to have the whole of the wall covered with branches about 9 inches apart. If previous instructions have been attended to the lateral growth would have been shortened at the summer prunings, but unless again spurred back to a length of about 2 inches these permanent spurs soon become long and unsightly. As a rule the fan-shaped trees are the best for walls, but we have done well with horizontally trained Cherries, and cordon Plums are recommended by some good growers. It is yet too early to prune or nail the young newly planted trees, and remarks on this portion of the

subject may be deferred accordingly. Pyramids or bushes of either Plums or Cherries may be treated much the same as Apples and Pears—that is to say, may have all lateral growth not required for furnishing the trees spurred back to near the main branches, the leading growths being either freely shortened back, or, if there is plenty of head room, be left to their full length. Standards, especially of Plums, require to be freely thinned out, or the inside of the trees are profitless. Fore-shortening, or the act of cutting back the long straggling branches to better placed smaller ones, is also advisable.

Morello Cherries, which are very profitable either on north walls or as pyramids or standards, require different treatment to the rest. These fruit principally on the young growths formed the season previous, and this should therefore be merely thinned as well as much of the old wood as can be safely taken out, and that reserved laid in neatly. Also thin out the young shoots on the pyramids and standards, but do not shorten back those saved. The bulk of the fruit sold in the London markets is grown on standard trees, and these would also be found most profitable in private gardens if the birds, notably blackbirds, could be kept from the fruit.

#### FRUIT FORCING.

**VINES.**—*Early Forced Vines in Pots.*—Attention must be given to the fermenting materials in the pits, and if the pots are placed on pillars frequent additions of material should be made as the heat declines. The heat about the pots must be kept between 70° and 75°. The temperature should have been raised gradually after the buds commenced swelling from 55°, so as to have it about 60° to 65° by the time they are coming into leaf, allowing an advance of 5° to 10° by day, carefully admitting a little air at 70°, and close early. Disbud as soon as the bunches can be detected, reserving the most promising. Stop the laterals about two joints beyond the bunches. The laterals proper, or those on the growth of the current year, should be removed up to the bunches, and those beyond allowed to extend as the space permits without crowding, it being essential that the foliage retained have full exposure to light and air, and no more than that encouraged. Usually a couple or three joints of lateral extension are sufficient for fruiting Vines in pots, the crop preventing much further extension. Where fermenting materials are employed the necessity for the application of moisture will not be so great as where the heat is obtained solely from hot-water pipes. Evaporation troughs should be filled with liquid manure or guano water, one pound of guano to twenty gallons of water, which may also be employed for damping the floors, &c., after closing the house, or early in the afternoon.

*Early Forced House.*—The buds of Vines started last month now show signs of swelling, and another good watering should be given the inside border at a temperature of 85° to 90°, and in the case of old Vines liquid manure should be freely applied. From the time the buds commence swelling the temperature should be raised 2° or 3° in the course of a few days, not exceeding 60° to 65° by artificial means until the Vines have produced their leaves. In quick forcing, and where the Vines are thoroughly established and have had a long rest, growth may be induced by a brisk moist heat of 70° to 75°, continuing it until the eyes have fairly started growing, when the temperature should be allowed to fall to 60° to 65°, with 5° to 10° rise in the daytime, it being important whilst the foliage is being made that a moderate temperature be employed, in order to secure short-jointed wood and stout well-developed foliage. Young Vines that have not been forced early will need to be brought down to a horizontal position to ensure their breaking regularly. Some well fermented short stable manure and leaves placed in ridges on the inside borders will afford a genial moisture and warmth, and lessen the necessity for frequent syringing. See that the fermenting materials on outside borders are not cooled by snow melting on them, and lose no opportunity of turning and adding fresh material as may be required.

**STRAWBERRIES IN POTS.**—When the crowns commence swelling and the trusses appear the temperature may be advanced a few degrees by day. A temperature of 50° to 55° at night is sufficiently high for the present. Syringing the plants gently in the early part of bright afternoons will be advantageous. Examine the plants daily, and supply water to all those which require it. Keep a sharp look out for aphides, and if any appear fumigate the house on two consecutive calm evenings, or at this time of year it may be practised in the evening and early the following morning.

More plants should be placed in a house from which frost is excluded, the decayed leaves being removed, and the surface soil loosened and top-dressed with horse droppings rubbed through a sieve. The drainage should be attended to and if necessary rectified, and the pots washed. The plants may be introduced during the next three weeks to a Peach house or to a Strawberry house if such be available. La Grosse Sucrée, Vicomtesse Hericart de Thury, Sir Harry, and President are suitable varieties. Plants for introducing later on will be quite safe in their quarters out of doors plunged in ashes to the rim, and a light covering may be given of dry fern or litter in severe weather, removing it in mild weather.

**CHERRY HOUSE.**—To insure a supply of ripe Cherries from the middle of April and onwards houses which are to be employed for that purpose must now be closed. Be sparing of fire heat at the commencement, not employing it unless absolutely necessary to maintain the temperature at from 35° to 40° at night, and 40° to 45° by day, ventilating when the temperature is about 50° to 55°. Close the house at 50°. Syringe the trees and available surfaces early on fine afternoons, so as to

admit of the buds becoming dry before nightfall. The border will be sufficiently moist through the removal of the roof lights, if not it must have water to bring it into a thoroughly moist state. Trees in pots if at all dry will require repeated supplies of water to secure the thorough moistening of the soil to the base of the pots.

**FIGS.**—*Early Forced Trees in Pots.*—Early Figs are best secured from trees in pots, as a slight warmth at the roots is highly beneficial; but even this has its disadvantages, as when the heat at the roots is 70° or more during the early part of the forcing process the growth is too rapid, therefore see that the heat at the base of the pots is not more than that until the leaves are unfolding, when the temperature may be 75° or even 80° at the base of the pots. The temperature of the house should be increased gradually to 60° at night, 65° by day by artificial means in severe weather, 5° more in mild weather, 70° to 75° with sun heat and moderate ventilation, closing at 75°, but be careful not to bring on the growth too rapidly, especially in dull weather, as foliage produced under such conditions is not of stout texture, but thin and liable to scorch under bright sun, and to invite red spider. Water in a tepid state must be applied to the roots as required, and the trees and house must be syringed morning and afternoon, so as to have the foliage dry before nightfall, damping the house later in the day if the atmosphere has become dry.

#### PLANT HOUSES.

*Adiantum cuneatum.*—Plants from which the fronds have been cut must not be placed in too low a temperature or supplied with cold water direct from the main, or they will fail to start freely into growth. If they are supplied with tepid water and kept in a temperature of 50° until the early part of next month they will be safe, and may then be started into growth in some structure where the temperature ranges about 10° higher. Be careful not to allow moisture to fall or rest upon fully developed fronds. Nothing causes them to turn brown sooner at this period of the year. Keep young plants that are growing freely in 4-inch pots in a temperature of 60°. Water them carefully and keep the foliage dry. Small plants in thumbs may be kept in the same temperature; if possible plunge the pots to prevent the soil drying so rapidly.

*Asparagus plumosus.*—This is unquestionably one of the best plants that can be grown for the production of greenery during the winter months. It will do well in any cool structure where frost is excluded. In a cut state it is invaluable, and will last fresh in rooms for fully a fortnight. If plants have been stripped of all that is of service for cutting place them in heat, and they will soon commence growing freely and give abundance of material again in two or three months' time. If this plant can be placed out in a cool house it will soon attain a large size and yield a supply over the greater portion of the year.

*Fuchsias.*—Where these are required early prune plants that have been kept dry and have had a good season of rest. These should be introduced into a vinery or Peach house that is first started, or any other similar structure where they can be liberally syringed and the atmosphere kept rather moist. Good syringings will afford ample water for the first week or ten days, when the soil about the roots may be moistened with tepid water.

*Cannas.*—These are very useful and effective for groups in rooms and halls where gas is used and very little light reaches them. Introduce a few plants into the same conditions as advised for Fuchsias, and when they are starting divide the crowns and place them singly in 5 or 6-inch pots. If larger plants can be used place clumps with three or more crowns in 7 or 8-inch pots.

*Chrysanthemums.*—Give abundance of air to those required for flowering during January. The buds will swell rapidly and expand quickly at this season if the house in which they are placed is kept close. In case of frost use no more heat than is necessary to keep the temperature at 35°. Although the season has been a warm and bright one Princess of Teck will be plentiful until the end of January. But these are from plants that were kept outside until the severe weather of a few weeks ago compelled us to place them under glass. Every plant kept for late flowering has developed buds, and they are expanding freely, which is not always the case when the summer and autumn has been damp and sunless. Throw out all plants as the flowers fade that are not required for stock. Keep the old stools needed for this purpose in a late Peach house or vinery from which the foliage has fallen, give them plenty of air to keep them sturdy. Where plants are grown for the supply of exhibition blooms cuttings may be inserted at once. They can be inserted in a cold frame similar to Calceolarias in light sandy soil, and when they are rooted lifted and potted. Perhaps the best method is to insert them singly in small pots and place them under handlights, or in a frame in a vinery or other structure where the temperature will range about 45°. When rooted on the latter principle they can be grown without a check.

*Lapagerias.*—Those that have been grown in pots should, if practicable, be planted out, for they will grow much more rapidly under these conditions than in pots. When planted out and well established it is surprising what enormous shoots they push from the base, and the flowers are nearly double the size of those from pot plants. In planting them out be careful that the border is well drained, for they require abundance of water during the season of growth. Use for a compost rough fibry peat and good loam in equal proportions, with charcoal in lumps, and sandstone broken up, to be freely intermixed to keep the soil open and porous. They dislike a compost that will have a tendency to become sour.

## THE BEE-KEEPER.

### PRACTICAL BEE-KEEPING.—No. 25.

WHEN the bee-keeper does not desire to diminish the number of his stocks, and yet perceives that certain of his colonies require reinforcements of bees before they are in a fit state for wintering, it is advantageous to either beg or purchase a few pounds of driven bees and add them to the weak stocks. Driven bees can in many neighbourhoods be purchased at 1s. a pound; and although it is impossible accurately to gauge the number of bees which make a pound in weight, owing to the fact that gorged bees weigh more than those with empty sacs, and for other reasons of a somewhat similar nature, still, taking the average, it is, I think, a safe estimate to reckon that in a pound there will be at least 4000 bees. In effecting the purchase of driven bees, or in acquiring them by driving honey stocks for friends or neighbours, it is well to remember that in August every stock contains a quantity of old bees, many of which will die before the end of September; a pound, therefore, in August will contain a large per-centage of worn-out workers, while at the end of September many of these old stagers will have perished, and consequently a pound of bees at that time will be far more valuable than the same quantity in the preceding month. In any case, however, after adding 5 lbs. of driven bees to a stock the winter may be awaited with absolute confidence, and with the certainty that in the spring such a colony will give the best results as a reward to the bee-keeper for his trouble and expenditure. There is not the slightest difficulty in adding driven bees to established stocks. One precaution may be taken, and one only is required; indeed, in some cases a safe union may be effected without the exercise of the slightest care, but it is far safer to adopt the surest method. Late in the afternoon the bees to be united must be taken to the stock to which it is intended to join them. A sheet must be spread on the ground in front of the stock; two pieces of wood a few inches high must next be placed on the sheet. Six or seven puffs of smoke may then be blown in at the entrance of the stock, the driven bees with a sudden jerk being next thrown on to the cloth and sprinkled with scented syrup. The hive in which the stock is located may then be lifted from its stand and placed on the sheet, the opposite sides of the hive resting on the two pieces of wood in order to prevent crushing of bees and consequent loss of life. The hive must then be protected from the weather in any manner which is convenient, and when in the morning the stock has been replaced in its stand, which has, of course, been kept in a dry place during the night, the union is effected. If this method is not convenient the bees may, after smoking the stock and sprinkling the combs from above with thin warm minted syrup, be thrown upon the tops of the frames, and after also sprinkling them a quilt may be laid over all until the united bees descend between the combs, when the ordinary covering may be replaced in the usual manner.

If it necessary to unite two stocks—bees established in their hives—the colonies should be brought as nearly as possible together; both stocks should then be smoked and sprinkled with syrup, preferably scented, and the combs and adhering bees of both stocks be placed alternately in the same hive, the empty hives being of course removed. In these manipulations it is absolutely necessary that the syrup used should be very thin; if thick

syrup is used the bees will be absolutely glued together in one seething mass and many will perish. A few drops of essence of peppermint may be added to a pint of syrup in order to give it a scent sufficiently strong to deaden the difference in smell which undoubtedly exists, and is at once perceived by bees of different stocks when it is attempted to unite stranger bees to those already established in their hives. Some bee-keepers, however, never use any scent, and others adopt what I think is the needless precaution of taking the bees of the stock to which it is desired to unite the homeless bees from their combs, and thus rendering them less inclined to fight with one another, because they have neither of them anything worth defending.

With regard to the treatment of queens when uniting bees, so much depends upon individual circumstances that it hardly seems wise to lay down a hard-and-fast rule. In many instances the bee-keeper has no knowledge whatever, save by conjecture, as to which is the best queen. He knows that his stocks probably contain queens, but is utterly ignorant of their respective values. In such a case it is just as well to let the bees decide the question for themselves, not attempting to pick out the inferior queens, but leaving the point to be decided by the bees in their own way. But when an intelligent bee-keeper knows that one queen is very valuable and another comparatively worthless, the valuable queen alone should be saved and all the others killed by the bee-keeper at the end of the honey season. In some cases it is even wise to cage the queen until the union has been peaceably effected, and then some forty-eight hours afterwards release her, or the direct introduction method, about which we shall have more to say, may be used. Other things being equal a young queen is almost always preferable to an old one. The bee-keeper who bears in mind the fact that there are five main essentials to successful wintering, keeping in view the future harvest, will always take care to fulfil the conditions which ensure success. Briefly, these conditions may be said to be:—

- 1, A good queen.
- 2, A strong stock.
- 3, A dry hive.
- 4, Good ventilation without draught.
- 5, A sufficient supply of food.

When snow lies on the ground the strongest stocks may be confined to their hives if certain conditions are observed. Perforated zinc may be used to block the entrance, and a board should, in addition, be placed against the front of the hive to throw off the rays of the sun. Occasionally a little snow on the floorboard is also an assistance in the case of restless stocks on very bright warm days when soft snow is lying round the apiary. Many bee-keepers object to entirely closing the entrances of stocks, and maintain that by doing so strong colonies occasionally become excited and irritated by the confinement and are smothered to death. This may be so, but it has never happened in my own apiary nor in any apiary within my knowledge, but certainly a great loss of bee life has been occasioned when no perforated zinc has been used, but reliance has instead been placed upon the use of a board only. In warm sunny weather—even in midwinter—the air is often so mild that whether the rays of the sun fall upon the entrance or not many bees creep out and fly, and even if they do not perish in the snow they are utterly unable to find their way back to the hive—disguised by the board leaning against the front—but fly hopelessly about until by mere exhaustion they fall and die. Others, again, never either shade or close



the entrances, and they must therefore suffer great loss. Those who have experience to guide them may follow either plan, possibly with equal success, but those who have not yet had much practical experience in wintering bees will do well to close the entrances by perforated zinc, and also to shade their hives, opening every entrance at the earliest possible moment. Naturally, if the entrance is not closed until the sun has risen and warmed the hive there may possibly be a little disturbance, but the entrances of it always to be closed if possible at night or in the early morning, and there is no special occasion to remove either the zinc or board until the bees may safely be allowed to fly.

The greatest care must be taken to exclude mice from hives in winter. They not only destroy the combs by gnawing them to pieces, but they kill many bees, and otherwise injure the stock by exciting the bees when they ought to be perfectly quiet. In cold weather, when the clusters are compact, great injury may be occasioned. Lessening the entrances, trapping, and other means of either exclusion or extirpation must at once be resorted to if there is a suspicion that mice will enter, or have already entered, the hives. A sure sign of their presence is when pieces of comb somewhat larger than usually carried out of the hive are seen lying on the front board. If these are seen it is almost a certain sign of gnawed combs and other mischief, and the bee-keeper must consequently, during the winter and early spring months, be continually on the alert if he sees this flag of distress. Those who have experienced the depredations of a single mouse will need no spur to induce them to take proper precautions. Those who have not yet been favoured by a visit from these small but destructive creatures will possibly, when they least expect it, find that what has never happened before may happen within a very few weeks or even days.—FELIX.

#### ODOURLESS FOUL BROOD.

I AM much obliged to "A Lanarkshire Bee-keeper," page 480, for taking me to task for claiming too much in connection with the above. I do not pretend to be above making errors, therefore I am always pleased when a mistake is pointed out to me. Still, I am not yet satisfied that I am wrong. I did not, nor do I, claim that the "principle" is my discovery; but I do claim the way I carry it out as being novel. I have read and studied much on foul brood, yet I never saw or heard of my way being tried. If our friend can refer me to a publication containing it I shall be grateful to him. I always understood that Woodbury's or Jones' way was to starve the bees in confinement. I tried the plan, but soon condemned it when I saw the bees "unstarved" at the end of fourteen days. Mr. Jones now admits that twenty-one days will not starve them; then putting them on sheets of foundation is not the way to clear it out, as A. J. Root finds to his cost, as well as others. My way is the least trouble and expense of any plan, and cures the quickest. Another thing, keeping the bees in confinement until they have consumed all their honey is not the way to cure the queens, should they also be diseased.—A HALLAMSHIRE BEE-KEEPER.

#### PLACING BEES AT THE HEATHER—THE DISTANCE THEY WILL FLY.

THIS matter has been fully treated by "A Hallamshire Bee-keeper," and "A Lanarkshire Bee-keeper" has also referred to the matter. Perhaps you will kindly allow me to state my experience of bees at the Heather.

Firstly, I have had my bees placed among the Heather; secondly, I have had them placed about half a mile distant; and, thirdly, I allowed them to remain at home. My garden is about 500 feet above sea level, and there is a gradual rise to the moors of another 500 feet, and a range of hills from the background with an elevation of from 1500 to 1800 feet. First, we placed our hives where bee-keepers from time immemorial had placed theirs, just among the Heather in the shelter of a plantation, and some 900 feet above the sea level. Here my bees never did much, seldom a finished super being obtained. I observed that a very shrewd bee-keeper of my acquaintance placed his hive at a farm steading about 1½ mile distant to the north-west of where mine used to be placed, and at a lower level by 200 feet, with the advantage of a good road all the way, and always secured plenty of fine Heather honey from his hives. I resolved to follow his example, and the next season placed

my hives alongside of his. The result exceeded my most sanguine expectations, and as each season comes round I place my hives in the same positions with equally satisfactory results. The bees have a flight of about a mile before reaching the main body of the Heather.

In 1886 a neighbour placed his hives about 2½ miles back from the same Heather, with the result that he did not secure a pound of super honey; while from my hives placed within a mile of the Heather I secured supers of 16 lbs., 20 lbs., 25 lbs., &c. Last season he placed his hives beside mine and secured supers from every one. The distance from home to the stance at the Heather is only 4½ miles (bee flight), yet I never had returns of bees. The bees left at home did little more than sustain weight, and only in one instance did I secure a super, and it was principally filled from Lime trees, with cells of Heather honey through the combs. This I believe was gathered from patches of Heather growing in plantations near home. During the past two seasons I have been enabled to visit my hives at the Heather twice a week, some weeks oftener, and in all sorts of weather, but never found bees carrying honey except on fine days.

The result of my observations over several years is to place your hives in the most sheltered and convenient situation available, but not more than a mile from the main body of the Heather, so as to allow the bees a nice easy flight; and that no advantage is gained by placing bees too near the Heather, as they do not feed in the immediate neighbourhood of their hives.—MID-LOTHIAN.

#### TRADE CATALOGUES RECEIVED.

J. Carter & Co., 237 and 238, High Holborn, London.—*Illustrated Vade Mecum for 1888.* (Coloured plates.)  
Harrison, Barber & Co., 18, Queen Victoria Street, London, E.C.—*List of Chemical Manures.*



\* \* All correspondence should be directed either to "THE EDITOR" or to "THE PUBLISHER." Letters addressed to Dr. Hogg or members of the staff often remain unopened unavoidably. We request that no one will write privately to any of our correspondents, as doing so subjects them to unjustifiable trouble and expense.

Correspondents should not mix up on the same sheet questions relating to Gardening and those on Bee subjects, and should never send more than two or three questions at once. All articles intended for insertion should be written on one side of the paper only. We cannot reply to questions through the post, and we do not undertake to return rejected communications.

**Book (N. B.).**—If you will oblige with your name and address, not for publication, we will endeavour to supply you with the particulars required.

**Chrysanthemum Sport (H. H. F.).**—The variety Mrs. For-yth is synonymous with White Christine, and your "sport" is a reversion to the pink form of Christine, and it therefore could not receive a distinct name.

**Chrysanthemum Shows (Chorley).**—We are greatly obliged to gardeners and amateurs who favour us with reports of local shows, and we are always glad to insert such notices when they reach us within reasonable time of the dates of the exhibitions. In the present case, however, by the time the report appeared in our next issue nearly a month would have elapsed since the show was held.

**Lady Downe's Grapes (J. S.).**—As you give no reference to the article to which you refer, the insertion of your "omission" would scarcely have a tendency to promote what you desire. It is important that salient facts be kept in view in communications on important subjects, or they necessarily lose much of their force, if not leading to erroneous conclusions. Perhaps you had better restate the entire case. Postscripts two or three weeks old are regarded as somewhat out of date.

**Tomato Cardinal (Deal).**—We cannot answer your question better than by citing a paragraph from the Chiswick report of the trial of Tomatoes conducted this season. The varieties and synonyms were determined by the Fruit Committee of the Royal Horticultural Society, and, as you will see, Cardinal was considered identical with Perfection, this being certificated:—"Perfection (Farquhar); Livingstone's Perfection (Rutley & Silverlock); Livingstone's Favourite (Farquhar); Livingstone's Favourite (Dean); Perfection (Veitch); Reading Perfection; President Cleveland (Farquhar); Cardinal (Farquhar); Stamfordian (Veitch); Mayflower (Veitch); Optimus (Benary); Red Tomato, from Sandwich Islands (Carter); Webb's Jubilee (Webb); Jubilee (Nutting)."

**Vines at Garston (Dumfries).**—We have referred to the volumes of eight, nine, and ten years ago, and can find no such record, so that the subject is either omitted from the index or you are wrong in your supposition as to the date. You cannot expect us to conduct a tedious search through the columns of another journal in the absence of more precise guidance than you have afforded. If Mr. Cowan inserted Vine eyes in March, grew the canes, matured them, and cut ripe fruit from them within

twelve months from the insertion of the eyes or buds, several persons, such as his assistants and visitors, must have cognizance of the circumstance, and may possibly know the year in which the work was accomplished. We do not question the possibility, but what you appear to desire is verification of some record of a particular case. Perhaps now the subject is mentioned someone may be able to assist you in the matter.

**The Chrysanthemum Leaf-mining Insect (*G. Woodi*).**—The "maggots that form tunnels in Chrysanthemum leaves" are produced in the same way that the maggots are in the leaves of Celery. The name of the Chrysanthemum enemy is *Tryptera artemisiae*, which punctures the leaves, depositing eggs in them, these hatching into maggots that feed on the parenchyma of the leaves. This, or an allied insect, is exceedingly destructive to the larger-leaved forms of the white Marguerites—such as Chrysanthemum Halleri, the smaller leaved *C. fruticosum* being also attacked, but less persistently. We know of a gardener who insures his Celery against the attacks of the fly by syringing the plants once a week in the summer with a weak solution of petroleum, which he says does the plants good, while the Celery fly will have nothing to do with them, and he has the best Celery we have tasted this year.

**Pruning Roses when Planting (*S. D. Jones*).**—We should not hesitate to shorten the very long growths, reducing them about half, though we know they are often left uncut till spring, and Roses thus left unpruned, say till April, have grown very well, though we have also known some to fail. The difference may be attributable to the weather. Should the air be very dry over a long period, as it often is in February or March, when easterly winds prevail, the longer the shoots are the greater the evaporating surfaces, and consequently the greater the escape of the juices from the plants, at a time when the roots are inactive, and cannot absorb moisture from the soil to compensate for the loss. When Roses are dug up and planted in October and November they may commence rooting at once, and can then imbibe moisture to meet the demands of evaporation; but when planted now, and onwards, we suspect the roots remain dormant till the spring, and on this account we should shorten the branches as the safest course to adopt in conserving the moisture in the lower part of the stems. If a Rose tree is dug up in October, before the leaves fall, the moisture escapes from them, and the stems shrivel, but if most of the leaves are cut off the evaporating surface is reduced, and the stems remain the fresher. But, observe, we should only "half prune" now, shortening more closely in spring after the buds push from near the tops of the shoots, and if they grow an inch or more no harm is done by their removal.

**Mixed Laburnum (*Beta*).**—Your designation of the tree leads us to suppose that you refer to a Laburnum bearing both yellow and purple flowers. We have seen many of such trees, the variety being known as *Cytisus Adami*. In all probability this was originally produced upwards of fifty years ago in budding *Cytisus purpureus* on the common Laburnum. In this process it is supposed that a cell of the one species became divided and united to a cell of the other, and the result has been a plant producing not only flowers of each species separately, but others partaking of the characters of both. There are other instances in the vegetable kingdom in which a similar union of cells is believed to have taken place, but *Cytisus Adami* is the best known and best established. Mr. Fish has added the following interesting notes on the subject:—"The changes produced on the Laburnum when grafted are some times wonderful and wholly unaccountable. We have rarely seen the common or Scotch Laburnum sport into other varieties. We recollect of only one instance in which flowers of purpurascens appeared. But if you graft either of the Laburnums with *Cytisus purpureus* or *Cytisus supinus*, the vagaries which sometimes take place are astonishing. A small standard of *Cytisus alpinus* was grafted with *Cytisus purpureus*, and on the same branch will sometimes be found small pieces of yellow and purple, and at the very point strong shoots of the *Cytisus alpinus*, the 'blood' of the stock finding its way through the more weakly growth of the scion. What is remarkable is, that grafting or budding with one variety will frequently, as the plant grows, present you with three or four varieties."

**Raising Seedlings (*E. J. B.*).**—You ask how it is that some persons can raise new varieties of flowers that are deemed worthy of certificates while all those that you raise yourself are, when submitted to authorities are referred to in the disheartening terms—"not superior to existing varieties." Your disappointment may arise through not having the best varieties to save seed from, or you may not be expert in fertilisation; or again, you may only raise a small number of seedlings, or may possibly do what we have often seen—raise more than you have convenience for growing, retaining the best growers and throwing the weaker away. You will perceive many things have to be taken into consideration, and then there is the certainty of having an infinitely greater number of blanks than prizes in the work in question. It has been stated, for instance, that "Mr. Keynes of Salisbury sows every year, and has done so for many years past, 30,000 Dahlia seeds, and has averaged about ten named flowers for the last twenty years or more—a small per-centage, equal to one-thirtieth per cent: in this case, however, it would seem as if many good flowers must be lost, for 30,000 seedlings ought to give at least thirty varieties worth naming, or say one-tenth per cent. The late Mr. John Salter estimated that seedling Chrysanthemums worth naming averaged one in every 2000 plants, or one-twentieth per cent. Mr. Downie grows 500 Pentstemons or Phloxes to get ten first-rate novelties, this being at the high rate of 2 per cent. In the raising of plants that admit of careful manipulation, the rate is still higher—the result, no doubt, of the control of the raiser exercises. In the case of Dahlias, Hollyhocks, and Chrysanthemums, the raiser has not much control, but he selects the seed parent and watches over the growth of the seed, which is under control to some extent. The rare cases in which the cross-breeder goes direct to his work, and having in his mind's eye exactly what he wants, insures it right off; but this is not an everyday business."

**Material for Protecting Fruit Trees (*R. L.*).**—We have not found any better material for protecting fruit trees when in blossom than scrim canvas, which is sufficiently thick to afford the requisite protection without excluding air and light, these being essential for the strong development of the blossom. The material should, however, only be used at night during the prevalence of frost, or by day when frost prevails, removing it in the morning as a rule by 9 o'clock, and having it placed over the

trees by 5.30 p.m., earlier or later according to the weather and the season. Nothing is so fatal to fruit blossom as damp and unnecessary protection that is known as "coddling." It needs air, and for the performing of its functions it must be dry, our climate never being devoid of the requisite moisture for the development of the organs of fructification, a close confined atmosphere being more fatal to fruit blossom than a few degrees of frost with dryness. Whenever the atmosphere is warm, or the external air above 45°, the material should not remain over the trees, though it may be applied before that temperature occurs in the afternoon after a fine day in anticipation of a frost at night, and it should remain on until the atmosphere becomes genial; otherwise the harder the blossom and young growths are kept the less likely are they to suffer. Very close material is not good, as it prevents a change of air, and favours the accumulation of moisture; it is also too opaque and weakening, hence we find better sets of fruit under a double thickness of herring nets and spruce branches than under a constant covering of heavy material. Coating with oil would enhance the durability of the material, but it excludes air. Nettings with small mesh are suitable, the best being of wool. Scrim canvas rightly used has been found to answer for protecting fruit blossom in a situation 500 feet above the level of the sea in a cold district in Yorkshire.

**Names of Fruits.**—The names and addresses of senders of fruit to be named must in all cases be enclosed with the specimens, whether letters referring to the fruit are sent by post or not. The names are not necessarily required for publication, initials sufficing for that. Only six specimens can be named at once, and any beyond that number cannot be preserved. (*J. C.*)—All fruits are attended to as soon as is practicable, and we find some named under your initials on page 351 in our issue of October 20th. If these are yours that were sent on October 17th we think there was not much time lost over the matter.

**Names of Plants.**—We only undertake to name species of plants, not varieties that have originated from seed and termed florists' flowers. Flowering specimens are necessary of flowering plants, and Fern fronds should bear spores. Specimens should arrive in a fresh state in firm boxes. Slightly damp moss or soft green leaves form the best packing, dry cotton wool the worst. Not more than six specimens can be named at once. (*B. R.*)—1, *Sophranotis grandiflora*, a very good variety; 2, *Madevallia Lindenii*; 3, *Odontoglossum grande*, something like a variety known as *splendens*. (*L. T.*)—1, *Cymbidium sinense*; 2, *Asplenium viviparum*; 3, *Eranthemum pulchellum*; 4, Not recognised; 5, *Tradescantia zebrina*; 6, *Begonia metallica*.

COVENT GARDEN MARKET.—DECEMBER 14TH.

BUSINESS somewhat better, but prices remain unaltered except for best samples Grapes.

		s. d.		s. d.	
Apples, ½ sieve	.. ..	1 6	to 3 6	Oranges, per 100	.. .. 4 0 to 8 0
Nova Scotia and Canada barrel	10 0	18 0		Peaches, dozen	.. .. 0 0 0 0
Cherries, ½ sieve	.. ..	0 0	0 0	Pears, dozen	.. .. 1 0 1 6
Cobs, 100 lbs.	.. ..	55 0	0 0	Pine Apples, English,	
Figs, dozen	.. ..	0 0	0 0	per lb.	.. .. 1 6 2 0
Grapes, per lb.	.. ..	1 0	3 0	Plums, ½ sieve	.. .. 0 0 0 0
Lemons, case	.. ..	10 0	15 0	St. Michael Pines, each	3 0 5 0
Melon, each	.. ..	0 0	0 0	Strawberries, per lb.	.. .. 0 0 0 0

VEGETABLES.

		s. d.		s. d.	
Articokes, dozen	.. ..	1 0	to 2 0	Lettuce, dozen	.. .. 0 9 to 0 6
Asparagus, bundle	.. ..	0 0	0 0	Mushrooms, punnet	.. .. 0 6 1 0
Beans, Kidney, per lb.	.. ..	0 3	0 0	Mustard and Cress, punt.	0 2 0 6
Beet, Red, dozen	.. ..	1 0	2 0	Onions, bunch	.. .. 0 3 0 0
Broccoli, bundle	.. ..	0 0	0 0	Parsley, dozen bunches	2 0 3 0
Brussels Sprouts, ½ sieve	3 6	4 0		Parsnips, dozen	.. .. 1 0 0 0
Cabbage, dozen	.. ..	1 6	0 0	Potatoes, per cwt.	.. .. 4 0 5 0
Capsicums, per 100	.. ..	1 6	3 0	"    Kidney, per cwt.	4 0 0 0
Carrots, bunch	.. ..	0 4	0 0	Rhubarb, bundle	.. .. 0 2 0 0
Cauliflowers, dozen	.. ..	3 0	4 0	Salsafy, bundle	.. .. 1 0 1 6
Celery, bundle	.. ..	1 6	2 0	Scorzoneria, bundle	.. .. 1 6 0 0
Coleworts, doz. bunches	2 0	4 0		Seakale, basket	.. .. 1 6 1 9
Cucumbers, each	.. ..	0 4	0 6	Sballots, per lb.	.. .. 0 3 0 0
Endive, dozen	.. ..	1 0	2 0	Spinach, busbel	.. .. 1 6 2 0
Herbs, bunch	.. ..	0 2	0 0	Tomatoes, per lb.	.. .. 0 4 0 6
Leeks, bunch	.. ..	0 3	0 4	Turnips, bunch	.. .. 0 4 0 6

CUT FLOWERS.

Holly and Mistletoe now commencing for Christmas decoration.

		s. d.		s. d.	
Abutilons, 12 bunches	.. ..	3 0	to 6 0	Lilies, White, 12 bunches	0 0 to 0 0
Anemones, 12 bunches	.. ..	0 0	0 0	"    Orange, 12 bunches	0 0 0 0
Arum Lilies, 12 blooms	.. ..	5 0	8 0	Lily of the Valley, 12	
Asters, 12 bunches	.. ..	0 0	0 0	sprays	.. .. 1 0 3 0
"    French, bunch	.. ..	0 0	0 0	Marguerites, 12 bunches	2 0 6 0
Azalea, 12 sprays	.. ..	1 0	1 6	Mignonette, 12 bunches	3 0 6 0
Bouvardias, bunch	.. ..	0 6	1 0	Narciss, white (French) 12	
Camellias, 12 blooms	.. ..	2 0	4 0	bunches	.. .. 6 0 10 0
Carnations, 12 blooms	.. ..	1 0	2 0	Pelargoniums, 12 trusses	1 0 1 6
"    12 bunches	.. ..	0 0	0 0	"    scarlet, 12 trusses	0 4 0 9
Chrysanthemums, 12 bchs.	6 0	12 0		Poinsettia, 12 blooms	.. .. 6 0 8 0
"    12 blooms	0 6	8 0		Primula (single), bunch	.. .. 0 6 0 0
Dahlia, 12 bunches	.. ..	0 0	0 0	"    (double), bunch	.. .. 0 9 1 0
Daisies, 12 bunches	.. ..	2 0	4 0	Polyanthes, 12 bunches	.. .. 0 0 0 0
Eucharis, dozen	.. ..	4 0	6 0	Ranunculus, 12 bunches	0 0 0 0
Gardenias, 12 blooms	.. ..	6 0	9 0	Roses, 12 bunches	.. .. 0 0 0 0
Gladiolus, 12 sprays	.. ..	0 0	0 0	"    (Indoor), dozen	.. .. 1 0 1 6
Hyacinths, Roman, 12				"    Tea, dozen	.. .. 1 6 3 0
"    sprays	.. ..	0 6	1 0	"    red, dozen (French)	1 6 3 0
Iris, 12 bunches	.. ..	0 0	0 0	"    yellow	.. .. 3 0 6 0
Lapageria, white, 12				Stephanotis, 12 sprays	.. .. 8 0 10 0
"    blooms	.. ..	2 0	8 0	Tropaeolum, 12 bunches	2 0 3 0
Lapageria, coloured, 12				Tuberose, 12 blooms	.. .. 0 6 1 0
"    blooms	.. ..	1 0	1 6	Tulips, dozen blooms	.. .. 1 0 2 0
Lilium longiflorum, 12				Violets, 12 bunches	.. .. 1 0 1 6
"    blooms	.. ..	6 0	9 0	"    (French), bunch	1 3 2 0
Lilium lancifolium, 12				"    (France), bunch	3 0 5 0
"    blooms	.. ..	1 0	0 0	White Lilac, per bunch	.. .. 6 0 7 6

PLANTS IN POTS.

	s.	d.	s.	d.		s.	d.	s.	d.
Aralia Sieboldi, dozen ..	6	0	12	0	Fuchsia, dozen ..	0	0	0	0
Arbor vitæ (golden) dozen	6	0	9	0	Hyacinths, dozen ..	9	0	12	0
" (common), dozen ..	0	0	0	0	" (Roman), doz.	9	0	15	0
Asters, dozen pots ..	0	0	0	0	Hydrangea, dozen ..	0	0	0	0
Azalca, dozen ..	30	0	43	0	Lilies Valley, dozen ..	36	0	42	0
Begonia, dozen ..	4	0	9	0	Lilium lan. folium, doz.	0	0	0	0
Capeicus, dozen ..	0	0	0	0	" longiflorum, doz.	0	0	0	0
Chrysanthemums, dozen	4	0	12	0	Marguerite Daisy, dozen	6	0	12	0
Cineraria, dozen ..	0	0	0	0	Mignonette, dozen ..	0	0	0	0
Dracæna terminalis, doz.	30	0	60	0	Musk, dozen ..	0	0	0	0
" viridis, dozen ..	12	0	24	0	Myrtles, dozen ..	6	0	12	0
Erica, various, dozen ..	9	0	18	0	Palms, in var., each ..	2	6	21	0
Euonymus, in var., dozen	6	0	18	0	Pelargoniums, dozen ..	0	0	0	0
Evergreens, in var., dozen	6	0	24	0	" scarlet, doz.	3	0	9	0
Ferns, in variety, dozen	4	0	18	0	Poinsettia, dozen ..	12	0	15	0
Ficus elastica, each ..	1	6	7	0	Solanum, dozen ..	9	0	12	0
Foliage Plants, var., each	2	0	10	0	Tulips, dozen pots ..	6	0	9	0



BREAKING UP LAYERS.

OUR correspondent "A. D.," to whom we recently gave some advice about the breaking up of old leas or layers, shows his appreciation of it by sending to us a full account of his intentions in the cultivation of a small farm of ninety acres, and in doing this he asks us several questions, the answers to which will, we think, be useful to our readers generally.

The best crop to sow on old lea, or layers of eight or ten years broken up now or during winter, is undoubtedly Oats. This crop should be sown as early next March as the state of the soil and weather admits, in this way. First of all apply the manure mixture broadcast, harrow once, then drill in the seed and harrow sufficiently to cover it well. The advantage of thus using the chemical manure is that in a dry season the moisture in the soil acts upon it sufficiently to render much of it available for plant food by the time the crop is ready for it. We would not, however, bury the manure deeply in the soil, because of the risk of much of it being carried down into the subsoil in a wet season. The cash price of the manure should be about 23s. 6d. per acre in any good central market or large seaport.

If farming can be carried on successfully anywhere in this country it ought certainly to answer with "A. D.," whose land is of good staple, well drained, well sheltered, and within a mile of a large town. With such exceptional advantages our correspondent is quite right in his preference for dairy farming, in which he will find both Oats and Oat straw most useful. To this crop we would add others of roots including Mangolds and Carrots; but unless it is his intention to steam or boil Turnips we certainly do not recommend them for dairy cows, raw Turnips invariably imparting an unpalatable flavour to butter. In breaking up old leas for root crops we should first plough deeply, and then, when the soil has by exposure become slightly friable and mellow, it should be cross-ploughed and so left till spring. The cross-ploughing brings the grass to the surface, and therefore as soon as the weather is favourable in spring the soil must be harrowed down, well stirred with a cultivator, and as much of the grass taken out of it as can be shaken free from soil. If the grass can be burnt in small heaps collected together all over the field it should be, both as a saving of labour and for the value of the ashes for manure.

Ploughing, harrowing, and rolling may have to be repeated again and again till the land is really clean. It is then ridge-ploughed for Mangolds with a double-breasted plough, and farmyard manure at the rate of 14 tons per acre spread along the furrows, which should be some 30 inches apart. Chemical manure is also scattered along the furrows, and is a mixture consisting of  $\frac{3}{4}$  cwt. nitrate of potash,  $1\frac{1}{4}$  cwt. nitrate of soda, 2 cwt. of steamed bone flour, 1 cwt. ground coprolite, 1 cwt. common salt, at a cost of about 43s. per acre. The ridges are then split down the middle by passing the double-breasted plough through them, thus closing the soil over the manure and forming new ridges, along the top of which the seed is drilled, and the soil closed over and about the seed by means of a light roller.

The grass retained for permanent pasture should about the end of February have a dressing sown broadcast upon it  $\frac{1}{4}$  cwt. nitrate of potash, 1 cwt. nitrate of soda,  $1\frac{1}{2}$  cwt. superphosphate,  $\frac{1}{4}$  cwt. steamed bone flour, at a cost of about 20s. per acre. See that all permanent pasture is not suffered to remain badly infested with noxious weeds. Docks, Thistles, Nettles, Gorse, Broom, Rushes, and Ononis are the most troublesome pests, and care should be taken to eradicate them from it. Remember that permanent pasture requires an annual spring dressing of manure to render it fully productive. In addition to sound, fertile, permanent pasture, we would have a piece of Giant Rye to mow early, and chaff with dry fodder for the cows, and a piece of Perennial Rye Grass for a successional crop to the Rye in spring, and for grazing or mowing throughout summer. Neither of these useful crops can now be had for next spring, and we only mention them in passing.

Carrots are drilled on the flat in rich soil, and as only enough are required to afford a supply for the cows, say from October till January, we prefer to sow rather closely, and to keep them clean by hand-hoeing. We are aware that the rows are frequently made so far apart as to admit of the use of a horse hoe, and on large farms this plan may answer well enough, but on a small farm we would not have the rows more than a foot apart. It will be understood that the Carrots are intended for use till the Mangolds can be used freely.

WORK ON THE HOME FARM.

All possible care must now be taken to keep the ewe flock quiet and well nurtured. A neighbour of ours who has a valuable flock of black-faced ewes, got together at great cost, had them recently driven out of the fold at night, chased for half a mile, and much bitten by dogs. He thought a stray sheep dog had done it, but we suggested poachers' lurchers, and we were probably right, for his watchmen have seen no night dogs, and the poachers are likely to avoid the neighbourhood of that farm for some time to come. The consequences of such a fright upon pregnant ewes may eventually prove most disastrous, and the farmer will indeed be fortunate if he has not several cases of abortion at lambing time. Not only should the ewes be kept quiet, but they should be kept on sound wholesome food, and on land that is firm to the tread. To fold ewes now upon soft sodden soil is not a advisable, for the strain upon the frame is very trying, as the feet become clogged and are moved with difficulty.

Our flock of young ewes have been in folds on Mustard for a few hours daily, whenever the weather was suitable, but they were always taken off at night to sound dry pasture, and were given unthrashed chaffed Oat straw. This has enough grain with it to render it very nourishing food, and it is obvious that it is worth while to effect such a saving in threshing corn. Many flock masters are already much straitened for means to feed the sheep, and should next spring prove a late one, both ewes and lambs will probably be disposed of early. Repeatedly of late have we been pressed to purchase hoggets at such low rates that "they must pay." We hold, however, that there should be no haphazard purchasing of farm stock simply because it is cheap. Keep well within the scope of your means, say we, and do what you undertake as well as you can, and above all things have a purpose and plan thoroughly well considered in reference not only to the purchase of stock, but of the provision of food for it, and to its final disposal. Because we do so, and exercise ordinary prudence in the management of our sheep and other live stock, we have been called lucky, when in point of fact luck had nothing to do with our business.



MANURES IN RELATION TO AGRICULTURE.

[An address delivered by Mr. Edward Luekhuis at a meeting of the Ipswich Farmers' Club, on December 1st, 1887.]

(Continued from page 508.)

If we require proof of a general and widespread feeling that it is possible to do better than cling to the muck cart, I have only to point to the experimental work going on all over the country; of the owners of large estates who are promoting such experiments—all by liberal subscriptions; and many who are having them tried on their own property. I may mention Sir Thomas Acland, the Duke of Norfolk, the Duke of Richmond, Lord Sheffield, Sir Spencer Wilson, the Marquis of Huntley, Major Sergisson, Lord Brassey, Mr. Faunce de Laune, Lord Cranbrook, the Duke of Devonshire, Lord Leconfield, and Lord Winterton. Of the action of farmers in this matter, I may mention the West Norfolk Farmers' Manure Company, composed entirely of practical farmers, with the exception of Mr. Thomas Brown, the very able chemist of the company, to whom, personally, I am indebted for many useful practical hints in the application of manures. Then, too, in Essex, we have an association under the guidance of Professor Dyer; in Sussex in the south, and Aberdeenshire in the north, there are associations under the very able management of Professor Jamieson, and we are all familiar with important work of Sir John Lawes and Dr. Voelcker.

Of practical results I have such a mass of information ready to my hands that it is impossible to include much of it in such a paper as this. I must, however, invite special attention to the result of Mr. F. J. Cooke's Barley experiments at Fritcham Abbey, in Norfolk, last year. Upon one plot he used 3 cwt. of nitrate of soda and 3 cwt. of superphosphate per acre; upon the other plot he used the same quantity of nitrate of soda and superphosphate, with the addition of 2 cwt. of muriate of potash, and by an expenditure of 16s. for the potash he obtained 45 bushels more marketable corn per acre than he had upon the plot where no potash was used. This one fact will suffice to show what good work is being done in Norfolk. It has gone on this year upon the farms of Mr. Cooke at Fritcham; Mr. Sapwell at Aylsham; and Mr. Garrett Tayler at Whitlingham. It was my privilege to meet those gentlemen with Mr. Clare Sewell Read at Whitlingham experimental field on the 30th of last July, and what I saw then enables me to say that the forthcoming report will contain much useful information derived from the extensive and very thorough trials of different manures upon corn, roots, and pasture.

An account of the great work done by Professor Jamieson in Aberdeenshire and Sussex during the last eleven or twelve years would of itself afford useful matter for discussion for several evenings, and I must therefore avoid any attempt to give anything like a full statement of it now. But I am personally so greatly indebted to Professor Jamieson, and the results achieved by him have such a high national importance, that I must beg your forbearance while I give a slight sketch of what has been done in Sussex. The Sussex Association for the Improvement of Agriculture owes its origin to Major Sergison of Cuckfield Park. I have heard him tell how during a visit to Aberdeenshire in 1880 he was so much impressed by the importance of the results of the experiments which had then been carried on for five years by the Aberdeenshire Agricultural Association under the guidance of Professor Jamieson, that upon returning to the south he gave an account of what he had seen in some letters to the newspapers, the result being a meeting of agriculturists at Brighton, and the formation of the Sussex Association with an annual income from voluntary subscriptions of from £500 to £700, and with Professor Jamieson as chemist to the Association.

From the outset Professor Jamieson stated he came to teach no new thing; the sum and substance of his doctrine was common sense applied to chemistry in its relation to agriculture. In point of fact, his aim was to induce farmers to see for themselves which were the most efficacious and most economical forms of manures; to understand the nature of the soil they had so long essayed to cultivate, and to learn how to face the depression of agriculture with a full hand, by getting more out of the land than they had ever done before. The entire work was emphatically educational, but he had special "Educational Plots" where was shown a method of analysing the soil by a process of partial manuring, in a systematic manner, by means of which farmers were taught how to obtain exact information of the state of the soil by making the soil analyse itself as it were. I shall be happy to explain the details of this work at some future meeting, and it must suffice now to say that the great practical outcome of the trials upon the Educational Plots was that the only manurial constituents to which farmers need give attention are nitrogen, potash and phosphorus. A farmer therefore only had to make himself acquainted with the forms in which they could be got, ascertain the composition, and state of division, and the price, and the work was reduced to simple calculation, which any farmer could accomplish.

In every report—at every meeting—farmers have been urged not to use any manure—merchants' mixture, but to procure each sort of manure separately, and to have them mixed under careful supervision at the farm. To assist them so far as was possible in this important operation, an annual manure recommendation circular has been issued, wherein the name and quantity of the most suitable manures for grass, corn, and root crops were given. This circular has become more valuable every year. This year it was published in February, and in addition to exact quantities of each sort of manure for each crop, the characters and

descriptions of the manures were given, with the market prices in bags free on rail in London, and the cash price of the mixtures per acre, as follows:—

	£	s.	d.
Grass mixture, about .....	1	0	0
Wheat mixture, about.....	1	11	0
Oat and Barley mixture, about .....	1	3	6
Swede and Mangold mixture, about.....	2	3	0

Fourteen tons of farmyard manure were to be used for roots in addition to the chemical manure, which would bring the amount per acre for roots to nearly £5. If that amount is condemned as excessive, I would point to a paragraph in the *Land Agents' Record* of November 12th, where we are told that Mr. S. Sherwood took the first prize at the Framlingham Farmers' Club in the previous week, for the best 3 acres of Mangolds, the manure for which cost £6 10s. per acre, and the crops weighed 45 tons per acre. I suppose nobody will question the editor's remark, that the result wholly justified the expenditure.

I have thus, in a very cursory manner, striven to show something of the great work now being done to enable British farmers to overcome difficulties which, under the heavy cloud of depression that is now hanging over us, would, without special effort on our part, prove insuperable. If aid from without in any form can be had, grateful indeed shall we be for it. Meanwhile, let us exert ourselves to do all we can to secure help from within, to foster a spirit of self-help and manly independence, to show that our section of the community has its full share of the national trait of never knowing when we are beaten. We are engaged in a contest in which our very existence as farmers is at stake, and our efforts are handicapped by our farm produce being placed in competition with similar produce imported from the best markets in the world, by keen speculators ever on the watch to glut our markets with foreign corn and cattle when they are certain of a margin of profit upon their investments. If, therefore, it is possible by improved methods of culture to obtain better crops in a more economical manner than has hitherto obtained among us, I venture to hope that I have your approval of my efforts to help so good a cause this evening.

THE LIVE STOCK JOURNAL ALMANAC, 1888.—We have received a copy of this publication, and conceive it to be of great use to farmers and others who are interested in stock of various kinds, also in poultry, ducks, and pigeons. It is a comprehensive work of nearly 250 pages, including a breeders' directory. Special articles from leading authorities on the subjects treated form a prominent feature, and the work is copiously illustrated. It is published at 9, New Bridge Street, Ludgate Circus, London.

OUR LETTER BOX.

Potatoes for Cows (*An Inquirer*).—Raw Potatoes are neither a palatable nor nutritious article of diet for cows, and we altogether object to using them in such a manner. Cooked, crushed, and with enough salt mixed with the mass to render it palatable, it forms a tolerably nutritious article of diet, but its effect upon a cow would not be a material increase in the milk supply, and the advantage of its use for such a purpose could hardly be commensurate with the labour in its preparation. We do not recommend it. Your selection of feeding stuffs has certainly the characteristic of novelty, damaged flour being as uncommon in cow dietary as raw Potatoes. Try about 4 lbs., mixed with an equal quantity of bran daily. If the mixture is not taken freely by the cows, mixed with minced Carrots and sweet chaff would ensure its consumption, provided the flour is not mouldy and sour. If the flour is really sweet and wholesome, its tendency might be to enrich the milk and assist the system in keeping up a full flow, but it is hardly calculated to increase it.

METEOROLOGICAL OBSERVATIONS.

CAMDEN SQUARE, LONDON.

Lat. 51° 32' 40" N.; Long. 0° 8' 0" W.; Altitude, 111 feet.

DATE.	9 A.M.					IN THE DAY.				Rain	
	Baromet. at sea level.	Hygrometer.		Direction of Wind.	Temp. of soil at 1 foot.	Shade Temperature.		Radiation Temperature.			
		Dry.	Wet.			Max.	Min.	In sun.	On grass.		
1887.											
December.	Inches.	deg.	deg.		deg.	deg.	deg.	deg.	deg.	In.	
Sunday .....	4	29.873	43.8	42.0	S.W.	42.2	47.2	43.2	50.7	41.7	0.124
Monday .....	5	29.993	35.5	35.6	N.W.	42.4	43.2	35.6	63.8	31.2	—
Tuesday .....	6	29.598	40.8	38.1	S.	41.2	44.1	35.4	50.3	28.9	0.027
Wednesday..	7	29.631	33.7	32.2	S.W.	40.3	39.4	31.9	63.3	26.7	0.041
Thursday ..	8	29.761	38.4	38.0	S.E.	39.3	53.8	33.1	54.5	28.2	0.262
Friday .....	9	29.419	48.6	44.6	W.	40.8	51.6	37.9	74.7	37.3	0.014
Saturday ....	10	29.835	38.9	35.1	N.E.	41.4	42.2	38.1	47.6	31.3	—
		29.745	40.1	37.9		41.1	45.9	36.5	57.8	32.2	0.463

REMARKS.

4th.—Fine, but cloudy throughout, with slight showers in the evening.  
 5th.—Cloudy early; bright day.  
 6th.—Overcast morning; squally, with showers from noon to 2 P.M.; then sunshine, followed by variable weather.  
 7th.—Fine and bright early; clouded about noon; a few flakes of wet snow about 1 P.M. then variable.  
 8th.—Wet all day.  
 9th.—Fine and pleasant, and generally bright.  
 10th.—Fair early; slight snow showers from 10 A.M. to noon; cloudy afternoon.  
 A variable but on the whole seasonable week. Temperature about 1° below that of the preceding week, and almost exactly the average.—G. J. SIMONS.



## COMING EVENTS

22	TH	Royal Society at 4.30 P.M.
23	F	Quekett Club at 8 P.M.
24	S	
25	SUN	CHRISTMAS DAY.
26	M	BANK HOLIDAY.
27	TU	
28	W	

### NOTES ON THE PAST ROSE SEASON.

**I**T seems rather incongruous to offer any notes upon Roses at this time of year, but the best rosarians are true enthusiasts, and, as "Horace Vernet" remarked some time ago in the *Journal*, it is the man who thinks and cares for his Roses in snow and frost who will come to the fore in July in the exhibition tent. A few years ago a party of gentlemen were out partridge driving in January. The sport was somewhat slow, and the weather cold and depressing; but two of them seemed to enjoy themselves thoroughly—they had not met since the summer, and they chatted away, whenever they could get together, all the day long. "What could it all be about?" said the others; "there are those two fellows together again, instead of in their places." One came nearer to overhear—"Bless me! it's all about Roses!"

It is this enthusiasm which brings men to London in December from all parts of England to attend the meeting of the National Rose Society; but they have the motto "Floreat Regina Florum" deeply at heart, and much enjoy all talk about their favourite flower. I wonder if any of them are of the same opinion as myself, that at Rose shows single blooms should be set at one fixed distance apart in all stands, and that a modification of the same rule, tending to uniformity, should apply to triplets. It seems to me that it would be fairer, easier, and simpler for judges, exhibitors, and spectators, and would put all competitors upon a more equitable footing. I know that some do not agree with me in this, and all will allow, I think, that some credit should be given to showing and setting-up; but my question is, Would not enough still be granted by some such rule as I have suggested?

The past Rose year has been noteworthy for the passing away of the professional and amateur championship trophies from Essex; and, as East Anglia is the driest part of England as regards rainfall, it would seem at first sight as if the exceptional drought of 1887 had a good deal to do with this result. But I fancy the drought was more felt in the north-west and south-west of England than it was in the east, which is, to a certain extent, accustomed to and prepared for it. Still, an unusual season will always produce unusual results, and East Anglians do not despair of bringing back both the trophies again in triumph.

The Rose shows in East Anglia are seldom reported in the *Journal*. They are not on the way to anywhere. A competitor from other parts of England is quite a rarity, and I fear it is hopeless to expect "D., Deal," to pay them a visit. But good Roses are grown and shown

there, and although East Anglians are much handicapped at the National Exhibitions by a deficient train service, all the Rose-growing world knows the two late champions in Essex, and that it takes a good man, let him come whence he may, to beat the rector of Scole in Teas.

Another feature of the past season was the unusually poor display of autumnal blooms. This was, of course, owing to the weather—the drought continued, but the sunshine did not; in fact, the last week of August and the whole of September and October seemed as noteworthy for the absence of sunshine as the earlier parts of the year had been for its presence. Our excellent Secretary told us last year, unless I am mistaken, that in 1886 Madame Gabriel Luizet was one of his best autumn bloomers. It was not so with me, and in the past season it was the worst—worse than François Michelin. I had one late flower of Her Majesty; I do not think it was strictly a second bloom, but I am sure we must all have been glad to find her blooms as good as they were. It struck me that most of those I saw exhibited were cut too late and too large. I found that when cut quite small they were much better in shape and colour. It is when they reach the flat expanded stage that one hears the muttered verdict—"coarse."

I know little of the new Roses, and hope that "D., Deal," and "T. W. G." will be kind enough again to give us some information about them; but I had two or three good blooms of Mrs. John Laing, and hope that this gold medal Rose will be included in the National Rose Society Exhibition list.

The question of stocks seems likely to be a fruitful theme of discussion for some years. The Manetti has lately been waning in favour; but it is not probable that nurserymen will abandon it. Indeed this stock has lately found a powerful advocate in an unexpected quarter, and I hope that he will, as he says, "cut many more blooms from Manetti to put in the champion stand of seventy-two;" but I fancy that it will be gradually discontinued by amateurs for all but the strongest growing H.P.'s.

With regard to the relative merits of cuttings and seedlings of the Briar, it is well known that the former spread their roots almost horizontally, while the seedling stocks root deeper. I fancy this points to an adaptability on the part of each, not so much to different sorts of soil, as to different modes of treatment. If a man plants his Roses in November, and, beyond just pruning them in March, cares no more for them till he goes to look for blooms at the end of June, it seems to me that the seedling Briar stock would be able to withstand such neglect the best; while, on the other hand, he who endeavours to feed his plants regularly and amply with proper nourishment, will succeed best with those on the Briar cutting, whose roots, being near the surface, are in the best position to assimilate all food supplied as quickly as possible. The points against the seedling Briar seem to be—that, from the time of sowing the seed, the stocks take longer to prepare; that a batch is generally of unequal size and strength; that they are not quite so easy to bud; and that the budded plants of H.P.'s are not so strong the first year, and are too late for exhibition. On the other hand it cannot be denied that Tea Roses make very fine plants upon this stock. Some assert that finer blooms of the Tea varieties are to be had from standards than from cutting or seedling Briars. It is difficult to say why this should be, and at all events the dwarfs are more easily protected from frost by the simple

process of earthing them up. Messrs. Cocker & Sons, of Aberdeen, have instituted a series of experiments upon the three stocks which I have mentioned, by growing a number of varieties on each of them side by side. For this they are much to be commended, but it remains to be seen whether they will succeed in establishing any facts which are not known at present.

The ordinary Rose pests were, with me, neither better nor worse than usual in the past season. We heard a good deal last year about Orange fungus or red rust, but I have hardly ever found it do any practical harm. I had some leaves among H.P.'s touched quite early in the spring, but it did not seem to spread. Some weakish seedling Briars were a good deal affected by it, but as these were to be budded with Teas, which are not liable to this parasite, I did not trouble about them. I have in most years had some H.P.'s which have lost a good many of their leaves in August from this cause; but I have found no harm beyond a possible weakening of the autumnal bloom. "Ah! but a loss of the leaves prevents a due ripening of the wood," someone said to me; but I do not see what is the use of ripened wood, if it is all cut clean away down to the ground in March.

Aphides trouble me but little, and I quite agree with Mr. Duncan Gilmour that, leaving out of account exceptional visitations like the winged swarms of 1885, Roses in vigorous health need fear little from this plague, I find the aphid brush the most speedy remedy for those I do have. When budding this last summer a row of Briar cuttings, I found there were a good many red ants about their roots; and, having occasion last month to transplant these cuttings with their dormant buds, I found on the underground stems and the roots adjoining them a quantity of aphides of a plum colour, but giving a yellow stain when crushed. I never heard of Rose aphides underground before, and hope they are exceptional, or they might be as bad as the phylloxera; but I imagine they were carried and established there by the ants, which were still in attendance upon them. It is known, I believe, that ants do transplant aphides, and treat them as their milch cows. The moral seems to be, Get rid of your ants by boiling water or other means. They will often completely eat up a fine bud, though I am doubtful if they ever make the first incision. I rather fancy they are generally attracted by the sap issuing from a hole made by a caterpillar, and, having once got at the sap, come "in their thousands," and finish the bud right off. However, Orange fungus, aphides and ants I do not mind. My two great enemies are mildew and thrips, and I know of no prevention for either.

The nature and life history of mildew has been most clearly shown us by Mr. Worthington Smith; but there is one thing about it I do not quite understand. I gather from his investigations that during the winter mildew spores, which have fallen with the leaves, rest in very minute damp-proof and frost-proof boxes (perithecia), which are only burst by the warm rays of the returning summer sun. How is it, then, that in attempting to force Roses in a house which has never had a Rose in it before, mildew is very apt to make its appearance, even in quite wintry months? Oh! for a preventive of mildew. For a remedy I have gone back to the old one of sulphur pure and simple.

I was never troubled by thrips till two or three years ago, but last year it was a great nuisance. I had not a single bloom of Madame Lacharme, Violette Bouyer, and Duchesse de Vallombrosa, which was not absolutely spoilt

by it. These three varieties were by far the greatest sufferers, though a dozen each of them was grown in two separate places amongst others. No doubt the drought had a good deal to do with it, and if the blooms as well as the roots had been well watered the thrips might have been banished. But then these are just the blooms which are ruined by wet after they begin to show colour, so that I was regularly in a dilemma. I tried different remedies with no effect, and of course anything that would stain the petals is inadmissible. I think I shall try wetting the buds, or applying something bitter, next year, before they show colour, but I have doubts as to the use of any such remedy. Any hints on this head will be gratefully accepted by—W. R. RAILLEM.

### HEAVY SOILS AND THEIR MANAGEMENT.

A GOOD, strong, holding soil when properly managed is one of the best a gardener can have to deal with, for as compared with a sandy soil it will grow better crops with less manure and retain its moisture much longer. To state that heavy clay soils are the best may startle some young gardener, it would have startled me six years ago. To see the water standing on the surface all the winter, and sometimes in summer too, like little ponds; to require two spades for digging, one to take up a spit and another to push it off with; and then in summer to see it bake like huge bricks, with cracks 6 inches wide and as deep as the cultivated soil; surely such a state of things may well startle any young gardener, especially if he has never seen what can be done with such soils. When in this deplorable state heavy soils are by no means the best. One of the sandiest description would be far preferable to it, for then we could grow autumn and spring crops; but with the other nothing is satisfactory, and unless a gardener be allowed sufficient labour and other facilities for bringing such soils into a friable condition, whether he be young or old, he has an especial claim on the sympathies of his brethren, for his life will be one of heavy toil, producing very meagre results. My object in writing this paper is to try and show how these close heavy soils may be made friable and capable of producing the best of flowers, fruits, vegetables, and farm produce, thinking it may be of use to some inexperienced readers of the Journal.

Burnt clay, or ballast as it is generally called, is an indispensable element for mixing with heavy soils to render them porous. Nothing we have tried equals it, and the manner in which plants of nearly all kinds root into it proves it beneficial to them. It seems to have the power of multiplying roots, for fruit trees will become a perfect mat of fibrous roots if a good quantity of fine ballast be mixed with the soil for them.

We have burnt thousands of tons of clay in the last five years, not merely because we wanted the ballast, but because acres of good land were covered with it, and many valuable trees were being killed because 2 or 3 feet of clay had been piled over their roots. The process of burning clay has already been described in the pages of the Journal, and "W. M.," page 356, has promised to send particulars of cost, so that it is not necessary for me to enter into detail on those points. I can, however, assure those who may wish to begin that clay burning is a very simple operation, requiring more common sense than skill, and that any labourer with a fair amount of the former will burn from 30 to 40 tons of clay with 1 ton of coal at 7s. per ton delivered, and that if the clay be carted to him will burn it in from three to four days—i.e., after the fire is well started. The ballast will require screening, but as that is generally done at odd times I am unable to state the cost.

Having secured plenty of rough and fine ballast we may proceed with the draining, for all attempts at improving the surface will be of little avail unless we provide good drains for carrying off the surplus water. Draining is an old practice, but is it thoroughly understood? or is it always done in a rational manner? I could point to instances where hundreds of pounds have been spent in draining without doing any good; in some instances the ground has been positively injured by being made less porous. Most gardeners and farmers know how to make puddle by treading and otherwise knocking clay about so as to stop up the pores that it may hold water, yet it is the custom for them to have the clay trodden, and sometimes even rammed, when it is being returned into the drain, thus stopping the pores of the clay and making puddle of it; neither is that all, for it stops the pores and joints of the pipes so effectually that it is impossible for either water or air to enter them. The primary object of burying draining tiles is the same as that of crocking flower pots—namely,



to allow the surplus water to pass out of the soil and the air to circulate through it, hence the same care should be exercised in both operations. To drain heavy land well the drains should not be more than 5 yards apart, and the main one, which will require 3-inch pipes; from 3 feet 6 inches to 4 feet deep. The sectional drains, which will run at right angles, or nearly so, with the main drain, and which will require 1-inch or 1½-inch pipes, should be from 3 feet to 3 feet 6 inches deep. Some complain that this is too deep for heavy clay land, but let it be remembered that if we can remove the sour subsoil water, the surplus surface water will take its place, so that by deep draining we sweeten, not only the surface, but the subsoil also, and that will be of great benefit to plants generally, and to trees especially.

When the drains are being dug do not allow the men to cut down the sides, it has the effect of stopping the pores in the walls of the drain, but get them to tear out the spit of clay; the walls will then be ragged and porous. When refilling the drains, put at least 1 foot of rough ballast over the pipes, and if there be sufficient, fill to the full depth of the subsoil with it. You will then have a drain which, unless it be mechanically disturbed, will be as effective after a hundred years as the day it was first laid. Of course cinders, clinkers, or any porous material will answer the same purpose, and if only 3 inches be laid on the pipes it will be much better than puddling the clay round them. The clay and soil required to complete the filling of the drains should not be trodden or rammed, but allowed to settle naturally. This may appear an expensive way of draining to some, but it is effective and lasting, and will drain the land better if put in three times wider apart than the ordinary drain will at the proper distance apart.

The draining being completed to our satisfaction, we must set about improving the surface, for even good drains will not of themselves bring a close doughy soil into a friable condition so that it can be worked comfortably at any time of the year and crops be had a month earlier. To effect this we want plenty of fine ballast and labour. If the soil be 15 inches deep, 9 inches of ballast will not be too much for it, provided it be thoroughly mixed with the soil. This is best done by trenching; but it is not enough to merely throw it back into the next trench, the soil must be well chopped up, and the fine ballast mixed with it as thoroughly as a champion Chrysanthemum grower would mix his compost. It may take some time to do, but remember it is an everlasting job. The ballast will never again return to clay, neither will it decay, but will be more effective every year as it becomes better mixed with the soil. For ordinary digging or ploughing 4 inches depth of fine ballast is ample, as then it is impossible to properly mix it with the soil. When used for flower beds and borders the ballast should be very fine, or it will have an unsightly appearance, when washed with the rain, from its red colour. We sift, what has already been screened, through an eighth of an inch sieve. What passes through is excellent for flower beds, the remainder is good for crocking pots. Should the flower bed soil be very close, let one-half of this very fine ballast be thoroughly mixed with, in the manner already described. The cultivator will afterwards find that he can make a hole without breaking his trowel, and that flowers and shrubs of all kinds, except Rhododendrons, Azaleas, and plants of that class, will grow rampantly and flower freely. We have used ballast with equally good results on the farm, and have this year had good crops of roots, while some of our neighbours have had to be content with bare ground, owing to the drought, which caused their land to bake and crack in all directions. It is a well-known fact amongst practical men that the finer and more friable a soil can be rendered, the longer it retains its moisture, hence the advantage of fine ballast for very adhesive soils, for when well mixed with them it prevents the particles of soil from running together, thus enabling the rain and air to pass freely through them.

Treated in this way, an otherwise unmanageable and unproductive soil will be converted into one of pleasure to the gardener and profit to the master.—J. H. W.

## PREPARING FOR CHRISTMAS IN COVENT GARDEN MARKET.

AN early visit to Covent Garden on one of the market mornings in the week before Christmas is extremely interesting and instructive, for at no other mart probably could such an enormous supply of vegetable products be seen. The space of the Market is under ordinary circumstances much too restricted, but at this time of year it is totally inadequate for the accommodation of sellers and buyers. The consequence is that within the Market itself the whole available space is blocked with bushels, barrels, boxes, and crates of all sizes piled in immense heaps and apparently in the most inextricable confusion. Outside the covered space waggons of Evergreens, Christmas Trees, Mistletoe, Holly, green vegetables, and Turnips

are packed together as closely as they can stand, while their contents are being transferred to the vehicles of the retailers which throng the approaches to the Market in all directions.

The Flower Market should be first visited, as that closes at 9 A.M., and it must be seen before seven to permit a correct idea being formed of the extent and diversity of the business transacted. This week amongst plants the most conspicuous are the scarlet-berried Solanums (*S. capsicastrum*), with which the Market seems to be filled. They are mostly compact bushy plants in 48-size pots and loaded with bright Cherry-like berries. For decorative purposes they are very useful, as they show well under artificial light, and they stand well with ordinary attention to watering. Pots of Tulips and Lilies of the Valley come next in abundance, and very showy the former look, the brighter colours being preferred, a few small Ferns being introduced in some cases with good effect. Some of the growers bring up the Tulips in large shallow boxes just as they have been forced, and they are purchased either for their flowers alone or for placing in pots for general decorative purposes. Heaths, especially *Erica hyemalis* and *E. gracilis autumnalis*, are sent to the Market in large numbers and seem to be in good demand. Palms, Dracaenas, Ferns, and *Cyperus alternifolius* are the principal foliage plants, the Ferns being remarkably numerous. Pterises of course predominate, but *Polypodium aurcum* is also a favourite, owing probably to its bold glaucous fronds, but several growers say it scarcely pays, as it is very slow compared with *Pteris serrulata*. Many market men complain that prices are low, and one experienced salesman says that what would bring £100 ten years since will now barely realise £20.

In the cut flower department Christmas Roses (Hellebores) are much in demand, the blooms realising from 1s. to 2s. 6d. per dozen, and the large pure white flowers of *H. niger maximus* are scarcely inferior to *Eucharis*. Roman Hyacinths are sent to the Market in large quantities, but they do not sell at remunerative prices, and some hundreds of bunches are unsold nearly every market morning. Lilies of the Valley are in fair demand, but 6d. per bunch of a dozen spikes at Christmas time can scarcely pay for forcing, especially when they cost 25s. to 30s. per thousand. Violets sell freely, and English grown samples of good colour realise as much as 2s. per dozen small bunches, while much larger bunches of imported Violets are being sold retail in the central avenue at 2d. each. A few late Chrysanthemums are seen, also Roses and *Eucharises*, but *Mignonette* is scarce. The spathes of *Richardia athiopica* are especially numerous this week, as they are much valued for church and other decorations; the spathes are also used largely for wreaths. Some of the florists in the central avenue make a specialty of choice flowers, and one in particular has a number of Orchids, comprising *Odontoglossum Insleayi*, grande, and crispum, *Cypripedium insigne*, *Laelia anceps*, and some *Oncidium*s. Small bunches of *Heliotrope* or Violets and *Mignonette* at 4d. and 6d. each appear to be favourites. Scarlet and pink Zonal Pelargoniums, with a few red Roses and *Bouvardias*, furnish the chief bright colours in contrast with white *Camellias*, *Eucharises*, and *Gardenias*.

The Fruit and Vegetable Markets are also well stocked. Of the fruit the chief supplies are the long flat cases of Oranges, of which there are some hundreds, and the barrels of brightly coloured American Apples, which are nearly as numerous. Continental and Channel Island Grapes, the former chiefly in barrels and the latter in flat handle baskets, are consigned in large quantities, the finer samples of home-grown late Grapes being confined mainly to a few leading fruiterers in Covent Garden and the West End. There are a few Pears, and the best samples command good prices, as also do the best of home-grown Apples. Nuts are invariably in considerable demand at Christmas, and the two leading depôts for these at the east end of the central avenue are now barricaded with scores of sacks and huge baskets of the principal sorts. Small Barcelona Nuts, Brazils, and Chestnuts are the chief, but Filberts, Cocoa Nuts, the Sapucaia Nuts, and a few Walnuts are also seen. Amongst imported tropical fruits the Pine Apple is the most important, and samples now in the Market comprise some remarkably fine fruits. The vegetables mainly consist of Brussels Sprouts, Potatoes, Savoys, Greens, and Turnips, with Onions. Of the first there has been a good supply, but the demand being also keen has kept up prices to a fair height.

In the outside market the great feature this week is the immense supply of Holly and Mistletoe, and it is astonishing how so much of the latter important adjunct to Christmas decorations can be procured. A large proportion is imported from the north-western departments of France, where it is grown extensively in the Apple orchards. It is packed in light crates about 5 or 6 feet square, and some thousands of these are forwarded to the London markets during the second and third weeks of December. They are mostly sold by auction, as also are the bundles of Holly, which are in similar demand. The samples in the Market this season are not

quite so well "berried" as they are in some years, and the price for good specimens is proportionately high. The evergreens employed in decoration include Cherry Laurel, Laurustinus, Aucuba, Ivy, Yew, and branches of miscellaneous Conifers, while the young trees of Abies, mostly cut off and inserted in pots, supply the "Christmas Trees" that afford so much delight to the juveniles. Numberless waggons loaded with these trees packed closely like dense miniature forests have made their way to the London markets this week, but Covent Garden has had the lion's share.

My visit was made early in the present week, and perhaps in another letter something may be told of another journey still nearer to the time of festivity; meanwhile this note may be concluded with the compliments of the season to all readers of the "Good Old Journal."—TOWNSMAN.

### MIGNONETTE IN POTS.

THE variety of Mignonette is often condemned as a poor weakly one when the fault has been due to the system of management practised. If the greatest care is not exercised during the dull sunless weather these plants are almost certain to continue growth, which will destroy the prospect of large spikes of bloom. These are not the result of weakly growth, but of the opposite; a close atmosphere or too high a temperature will start them into growth if they are now practically at a standstill. Growth during the dark days of winter should be so slow that it can scarcely be perceived. The plants should be arranged as near to the glass as possible, the pots standing upon some material that contains moisture, and placing them on dry shelves should be avoided. Sufficient water must be given, and at the same time excess must be carefully avoided, or the roots will perish. If the soil is allowed to become dust dry the foliage assumes a brownish yellow appearance and the shoots become woody. Free growth and large spikes need not be expected from plants in this condition. They will certainly produce short small spikes in profusion. Abundance of air must be admitted to them on all favourable occasions, and no more artificial heat than will insure their being safe from frost. At night, if the temperature can be prevented falling below 35° they will be perfectly safe. When admitting air avoid cold cutting winds, for it is better to keep the house closed. If severe frost sets in, and is likely to last long, more fire heat may be employed to keep the glass from being frosted and the plants in semi-darkness for two or three weeks. This would prove even more injurious than the use of fire heat early in the morning.

Plants subjected to this treatment will commence growing strongly in February, and if judiciously watered will have large dark foliage and large spikes of bloom. Mignonette in pots for decoration is by no means effective when the foliage has been browned by carelessness in watering during the stage of vigorous growth, but when they have been well cared for and have bold healthy foliage they are attractive amongst other plants in the spring. Plants from which bloom must be had should be kept in a temperature at night of 50° with a rise of 5° by day. If air is admitted daily when favourable they will grow slowly and continue producing small spikes that are serviceable for cutting. If they are kept too warm they will continue growing instead of lengthening their flower spikes. To have a constant supply during the winter a good number of plants must be sacrificed for the purpose—that is, as far as the production of large spikes are concerned. Plants that flower during the next two months will, if cared for, give abundance of small spikes suitable for cutting until this favourite flower can be had from frames in which seed has been sown early to precede that sown outside without protection.—W. D.

### FACTS ABOUT GRAPES.

#### MADRESFIELD COURT.

FOR the first time since the introduction of this now very popular variety no complaints of its cracking badly have reached me either privately or through the Press. This would rather appear to favour the theory that cracking is really the result of excessive moisture in the atmosphere, which penetrates the skins and fills the berries; but I am not yet convinced on that point. It would perhaps serve no good purpose to go over the old ground again, the controversy on the subject being yet fresh in the minds of many of the readers of the Journal, and I have no wish to revive it. For many seasons we have not had such a long spell of comparatively cloudless summer weather, and abundance of air had to be given early and late in some instances in order to prevent both the loss of foliage and berries by scalding. This evidently just suited Madresfield Court, few or no berries cracking, and plainly suggests one good remedy in less favourable seasons. Unfortunately in mixed vineries it is not often wise to unduly favour any one particular variety at the expense of the rest. For instance,

our best Vine of Madresfield Court is in a house principally devoted to Muscats, and being much earlier in ripening it would be unwise to admit air in quantity in order to prevent cracking during the ripening period, as this would be most prejudicial to the Muscats. Much as the Madresfield Court is liked for its table-quality, it being a really good companion for white Muscats, our Vine would have had to be sacrificed had we not heard of a fresh remedy for cracking. In the neighbourhood of Dorchester cracking is prevented, not by drying off at the roots and the admission of more air than is good for the rest of the occupants of the house, but as far as the drying off or starvation treatment is concerned, by totally opposite measures. This came as a revelation to me, and I am in hopes will in the future prove as successful as it has done this season. Not merely Madresfield Court, but all solid-berried Grapes, including Muscat of Alexandria, Mrs. Pince, Lady Downe's, Gros Colman, and Golden Queen require more liberal treatment than those with berries largely composed of sugar and water. We gave our Madresfield Court abundance of water with surfacings of Jensen's fish-bone manure whenever the border (an outside one) gave signs of approaching dryness, and the berries were larger and better finished than we have ever had them previously. Unfortunately it ripened at least six weeks too early for the shows, and this spoilt our chance for a good place in the prize list. Some of the best examples of Madresfield Court I have seen this year were shown at Trowbridge by Mr. John Bailey (Mr. B. Hopkins, gardener), Frome, and were rightly awarded the first prize in a good class for any black Grape of Muscat flavour. These bunches were grown in a mixed house, containing both Alicante and Black Hamburg, and were part of a heavy crop. All the Vines in the house received liberal surfacings of loam, manure, and bones, as well as a summer mulching of strawy manure and abundance of water. Let me, therefore, advise any of my readers who have not yet done well the variety under notice to try what a more generous diet and plenty of moisture at the roots at all times will do. Many succeed well with it up to a certain point, but fail to colour the berries properly, the result of a great anxiety to prevent cracking.

#### BLACK HAMBURGH.

I have already alluded to this old favourite (see page 399), but have not exhausted my facts about it. At the risk of being thought egotistical, I may mention having been fairly successful with the Black Hamburg, and could give a list of prizes won several years in succession, in good company too. Incredible as it may at first appear, much the best bunches have been grown in a flue-heated Muscat house, the only other black variety being the Madresfield Court just alluded to. It is a well-known fact that is an utter impossibility to properly colour the Black Hamburg in a Muscat temperature. It ought to be equally as well known that the lower or front portion is from 5° to 10° cooler than the rest of the house, notably near the roof, this being the natural result of the circulation of the air, the coldest being the heaviest, finding its way to the lowest portion of the house, this in spite of the flues or hot-water pipes. Our Vine of Black Hamburg was introduced from the next division and trained along the front of the house, the extra extension also greatly increasing the size of the stem. Being naturally earlier in starting than the Muscats, it is retarded by giving plenty of front air, while the top ventilators being kept close favours an early start of the latter, all of which are planted in an inside pit. Directly colouring has commenced front air is given, some being left on all night, and the hottest part of the flue is also covered with old sacking. This treatment, coupled with judicious cropping, results in a good finish, without any injury to the Muscats. Moreover, the wood always ripens well, the bunches are larger, and the berries set better than is the case in a house devoted to Black Hamburg. It is a good method of utilising the front of a house, and is a "wrinkle" for would-be prizewinners. I prefer it to the old-fashioned plan adopted by Mr. A. Crossman, gardener to Mr. J. Brunton, Yeovil. On one occasion that I visited this garden two rods in a mixed house of Vines appeared to have been filled, all the rest being once stopped. They had been kept outside of the house, and thus retarded, and were introduced when the slower ripening varieties had presumably got a good start, all then being ripened and given as much air as needed at about the same time. It was one of the many schemes tried by a gardener anxious to figure conspicuously in the show tent, and was attended with fairly good results.

#### GROS GUILLAUME.

This will never become popular among Grape growers for several reasons, but at the same time I consider its merits as a late variety much underrated. Well grown it keeps well, and is a most refreshing Grape, superior in fact to all but Lady Downe's, though not so rich as Muscat of Alexandria and Mrs. Pince. With some it is very shy fruiting, and in other cases it is quite the reverse, this I am fully persuaded being due to the fact that there is more than

one form of it in cultivation. The first time I fruited a rod newly inarched on the Black Hamburg stock two remarkably large and ugly bunches constituted the crop, and these having small berries were worthless. Nor was there any improvement the second season, and it had to make room for a more reliable variety. Mr. Ward of Longford Castle, who grows the Gros Guillaume (I should prefer the more pronounceable name of Barbarossa) better than I have seen it elsewhere, kindly sent me wood from his Vines, and with these we were successful in establishing a graft on the stem of an old Vine, and in inarching a young Vine on a growing shoot of Black Hamburg. Every strong lateral produced from the rods thus obtained was fruitful, and two bunches were left on each Vine to grow to their utmost extent. Our heaviest bunch this season weighed upwards of 8 lbs., this finishing beautifully, and all had berries nearly as large as the Black Hamburg. Unfortunately these big bunches are of little value. They are sensational, and that is the most that can be said in their favour, being too large for all ordinary purposes, and therefore also unsaleable. If instead of having two large clusters weighing 16 lbs. in the aggregate this weight was distributed through four or five compact bunches they would be of nearly double the value. Mr. Ward, however, secures handsome bunches with fine berries well coloured, and such examples look fine on either the exhibition or dining table. At Longford they have stands specially constructed for this noble Grape, and during the winter and early spring months they play an important part in the adornment of the dining table when large parties are held. Being thoroughly well ripened the quality also gives every satisfaction. It is a mistake to attempt thinning the berries when first set; in fact, very few, if any, need be removed at any time, or otherwise a loose bunch, which would settle down on a dish or show board like a pancake results. It may be advisable to take out a few of the smallest or stoneless berries after it is certain which these are, this being done for the sake of appearance, a few small berries detracting from the general effect. Very little thinning is done at Longford, but unless I am much mistaken Mr. Ward freely shortens back the long shoulders, a characteristic of the variety, or how comes it his bunches are comparatively shoulderless? This plan answers well in the case of other varieties, and I certainly hope to try it with the Gros Guillaume next season. Plenty of fire heat is necessary both for ripening the fruit and gross wood properly. There is no better stock for it than the Black Hamburg, but I have assisted very good bunches from a graft on a Lady Downe's. The rod of the latter was not interfered with in any way, and annually perfected about 20 lbs. of fruit, the graft of the Gros Guillaume being inserted at the bend caused by training it up the roof. Only one large branching spur of the latter was formed, from this being taken two bunches each year, these invariably finishing well. Those who are anxious to obtain plenty of bunches of this variety from old rods must not adopt the system of closely spurring back the laterals. We cut to a good plump bud, or to either the third or fourth joint.—W. IGGULDEN.

### CHURCH DECORATING.

It may be accepted as a very good and safe rule to follow, that too much labour bestowed on decorations is labour wasted. Simple arrangements, a minimum of material so long as there is sufficient and not too much variety, are the points to keep in view in producing a good effect. In draping walls, pillars, windows, &c., with evergreens great care should be exercised. Where the portion to be draped is massive or large, then wreathing of the same character should be employed, and perhaps nothing is better for this purpose than the common Laurel, or where the shade of green may be considered too light then the Portugal Laurel may be substituted. Tree Ivy is also very suitable. For wreathing of a lighter description—about 3 inches thick—common Box does very well. Wreathing less thick, for draping pulpits or galleries, is very prettily made up of sprays of either the Silver Queen or Golden Queen Hollies.

In the arrangement of the wreaths the style of the building has of course to be taken as the key to the whole, but in most if not all buildings a simple method of draping the walls as in the following manner will be as effective as a more complex arrangement. Taking the doors as points for the beginning and ending of the several portions of the design, it will be found most convenient to begin operations at one or each of these. Forming a hoop over the door the wreathing may be carried either to the nearest side of the window next the door, to the farthest side, or to the centre of the same, allowing the material to droop according to taste. If attached to the nearest side, then another loop is hung above the window by the wreathing being fastened to the farther side, and each window is treated in the same manner. If, however, the material is carried across to the side of the window farthest from the door, it is continued in the same way across each window, and a second line of material begins from the near side of the window, crosses the other

at its centre, and so continues till the last window is reached. This method is most suitable when the windows are large and rather far apart. By attaching pieces of wreathing to the highest points of the material put up as above, and allowing them to hang down the sides of windows and doors, a very good effect is produced. Where the wreathing is fixed over the centre of each window, these hanging pieces are attached either underneath the ceiling or where the wreathing passes. Mottoes may be introduced in any way thought suitable, the above method of arranging the greenery yielding a suitable setting to these.

Ends and organ recesses should be treated boldly but simply. Galleries may have an edging of Holly wreathing, such as already recommended, run round the top cornice, and neat loops of the same material carried between each of the panels, finishing with short pieces hanging from the points of intersection. The pulpit must be treated according to its character. When detached from the wall there is more room for diversifying the arrangement. If in the form of a platform, plants may well be arranged on its stage. If merely a box, then plants must be grouped only at its base. In any case the plants used should be as little formal in appearance as possible. In the first case a couple of tall Palms will be more effective and telling than any number of smaller plants, which would fail to show their character a short distance away.

With regard to dressing a box pulpit, where it stands well clear of seats a few Maidenhair Ferns dotted for a groundwork, with an out edging of Panieum or Isolepis and good Palms, Cyperus alternifolius, Bamboos and Curculigos not too thickly arranged among them, with a Calla or two, a few Calanthe vestita, and cut stems of late white and yellow Chrysanthemums have a very good effect. When divided from the body of the church by altar rails, these may be lightly draped with long shoots of Asparagus plumosus or tenuissimus, Cissus antarcticus, or variegated Ivy, a few tall Palms and Callas set behind this screen, and a neat free group of plants arranged in front. We have arranged a font—a wooden one—in various ways. Nothing prettier, however, can be made of it than by draping it with hanging shoots of Ficus repens, Panicum, or berried Fuchsia procumbens, these plants standing inside an outer row of Isolepis. A good plant, such as a Cocos several feet high, is required for the centre. A few tall spikes of Pampas Grass, and half a dozen growths of the same, cut a good length, is also placed near the centre, the long blades of the Grass, of course, drooping all round. A few small Maidenhair Ferns and Cyperus, with say three Arum flowers and a few Calanthes or Roman Hyacinths, make up what is a very pretty arrangement. Flattish window sills may be rendered very attractive by standing a line of Isolepis along the inside front, with a few Ferns or pieces of berried Holly covering the remainder, and one or more good plants standing well up from the others.—B.

### JASMINUM REEVESI.

ALLOW me to call your attention and that of the readers of your Journal to the Jasminum Reevesi as an evergreen flowering shrub which deserves far more extensive cultivation in suburban and other gardens than it at present obtains; in fact, for many years I have never seen more than one plant of it. Its hardy nature, bright deep metallic green foliage, healthy habit, and its beautiful umbels of golden yellow flowers most freely produced in August and September, should ensure it a place in every garden, and yet I have never been able to find it named in any of the catalogues of our principal nurserymen.

The specimen to which I allude was growing, and may be still, a few years ago in front of a terrace of houses in St. John's Wood, London, very near to the "Eyre Arms," and was perfectly healthy though quite uncared for. It grew in a cold stiff clay soil close to the dusty road, was sheltered from the east winds, but otherwise in an exposed and somewhat draughty position. Its height was about 4 feet. Will you kindly call the attention of your readers to a shrub which possesses such excellent qualities and well deserves to be grown?—W. M. B.

### DOUBLE PANSIES AND HEPATICAS.

DOUBLE PANSIES.—In looking through Parkinson's "Paradisus Terrestris," a valuable old gardening book published in 1629, I notice that he thus refers to Viola tricolor flore duplici (the double Heartsease). "We have in our gardens another sort that beareth flowers with more leaves than the former (the varieties of Viola tricolor are alluded to) making it seem to be twice double, and that only in autumn, for the first flowers are single that come in summer, that is of that sort that beareth purple flowers; and it is to be observed that the seed of this kind will not bring all double flowers, but some only, if the ground be fit and liking, so that if you once had a plant of this double kind, you shall seldom miss



to have double flowers again every year of its own growing or sowing."

Referring to Messrs. H. Cannell & Son's "Floral Guide" for 1887 they offer a "grand old double Pansy," and I wonder if this is a descendant in a direct line from the double mentioned by Parkinson. Mr. Hall of Truro and others cultivate an old double Pansy which is no doubt identical with Messrs. Cannell's "Old Double." Whilst writing on Pansies, I will just refer to the fuss made about the Trimardeau and other foreign Pansies, offered as beating everything in Pansies. This is misleading, for they cannot compare in beauty of colours and form, and in size do not excel the grand Fancy Pansies of the Scotch and English cultivators, and packets of seed can be bought readily at from 1s. to 2s. 6d. per packet.

HEPATICAS.—In "Paradisus Terrestris," already mentioned, the following list of Hepaticas is to be found—viz.,

- No. 1, Flore cœruleo simplici major (the great single blue).
- " 2, Minor flore pallido cœruleo (the small blue).
- " 3, Flore purpureo (purple).
- " 4, Flore albo minor (the lesser white).
- " 5, Albo magnifico (the great white).
- " 6, Albo fini argenteo (ash coloured or argentine) of a bluish ash colour changing to white.
- " 7, Albo flore straminibus rubro (white Hepatica with red threads).
- " 8, Flore rubro (red Hepatica).
- " 9, Flore purpureo multiplici fine pleno (the double purple).
- " 10, Flore cœruleo pleno (double blue).

No. 3 is described thus—"This is in all things like unto the first (No. 1), but the flowers are of a deeper blue, tending to a violet purple."

Parkinson adds the following note on Hepaticas: "They have obtained divers names, some calling them Hepatica, Hepatica nobilis, Hepaticum trifolium, Trifolium nobile, Trifolium aureum, and some Trionitas and Herba trinitas. In English you may call them either Hepatica, after the Latin name, or Noble Liverwort."

How many of these varieties exist now? Any information by growers of the Hepatica would be acceptable to many of your readers.—W. D.

## THE SETTING, STONING, AND SWELLING OF GRAPES.

THE thanks of the Grape-growing world are due to Mr. Stephen Castle for recording so honestly his experiences and difficulties. With your permission I will make a few remarks on the subject which seems most to perplex him.

There may be exceptional climatal conditions to be studied and overcome in his case, as I have found more than once in my career, but it appears to me that the principal thing wanting is for Mr. Castle to have a lesson on moderation.

Mr. Castle understands that potash is good for Vines, he directly goes and applies as much of that salt to them as I should have thought sufficient to pickle them. He makes up his mind from what he thinks conclusive experiments (which as he records them point, in my opinion, in another direction) that front air causes shrivelling, and he decides on giving little or no front air. He knows that lime is essential to the production of good Grapes, and he applies at least six times too much lime.

I wish I was sufficiently near him to look into the facts of the case myself, for I have no doubt I should learn something from what I saw; but as Mr. Castle is a close observer, I have no doubt he will be able to furnish me with the principal information I require to form a better opinion than I am now able to do.

Does all the wood ripen thoroughly, or do some of the growths remain green through their entire length? Is there a deficiency of pollen at flowering time? I like the pollen to fall on to the leaves in such quantities that they have the appearance of having been dusted with sulphur. Lastly, and most important, Is it possible for a common earth worm to live in Mr. Castle's border?

I do not recommend having a large quantity of worms there. I am not aware that they would do any particular good, but I do not think a border which is incapable of supporting a worm is fit to support a Vine. In other words, you may have quite a sufficiency of lime, potash, and phosphoric acid, and yet your Vines may starve. I believe, notwithstanding what has been added by "Proprietor," that this is the case with the Vines at West Lynn.

There has been, on Mr. Castle's own showing, sufficient lime (viz., 14 lbs. to the square yard) added to destroy everything in the shape of nitrogenous food that has ever been applied. As if one good dose was not sufficient it has been applied "three times a year,

never top-dressing or mulching without using it." Then I say the top-dressing or mulching did little or no good as far as feeding the Vines. Caustic lime should never be applied with manure, nor in any large quantity with rich soil. I should strongly advise that there be no more lime applied to the West Lynn Vines for at least two years.—WM. TAYLOR.

MR. A. YOUNG, on page 442, contributes a few lines on this, to me, rather important subject. The question is how to get berries with the proper quantity of seeds. Mr. Young would help further if he could ascertain if the berries that set without trouble are any better seeded. Alicante is doing precisely with Mr. Young as myself; truly the peculiarities of varieties are astonishing.

In reply to "Proprietor." For seven years before coming to West Lynn stoning did not trouble me. Early Hamburgs I had in at the end of March or beginning of April. What few Grapes I kept were mostly on the Vines up to the end of February. With gently tapping the rods and probably a better climate (Worthing) the berries set well. I should not, however, like to say the proportion of four-seeded berries were large compared with those having three or two stones. The use of lime has improved the Grape at West Lynn both in colour, flavour, and good keeping qualities. Fertilising and stoning may be two very different things, yet without fertilisation I have seedless berries, and these are the first to shrivel; therefore without doubt high cultivation is to be aimed at.

I believe I have gained immensely by using less front ventilation this autumn since the Grapes were coloured. Do not suppose by this I advise no front air. What I mean is we ought to be very careful in admitting the cold air. More top air, more fire, and less moisture at flowering time will be my routine in future.

"Proprietor" appears to overlook the fact that a too heavily cropped Vine is always the worst to both set and stone its crop the following year. Is there a gleam of light here?—weakness, and hence sterile flowers. Some Alicantes produced flowers in abundance, but small, with prominent anthers, and much pollen. I marked these. What do I find to-day? Berries rather smaller than in the bunches above or below, and wood only ripe to the fruit stalk, green beyond; berries with not more than two stones, mostly one. This must be weakness. One lateral is often very strong, the next weak; and this irregularity has not been explained.

As a rule, the number and character of the seeds or stones are in proportion to the size of the berries, yet in some instances the larger berry on a bunch has only two stones, this berry being rounder than the next berry with four seeds; but suppose the seeds weigh the same in each case, are not the two equal to the four? I have often found when one seed is imperfect the other is of unusual size. It has been my pleasure to dissect several berries growing at other places recently, and find the same defect and results as in my own, and a friend writing from Herefordshire says his experience is exactly the same as my own. Muscats run from one to three stones each, rarely four; Alicante and Gros-Colman average three stones each. "There can be no seeds without fertilisation." This is true, though in some instances self-fertilising suffices, though it does not in my case. I used no potash this season, as I had reason to believe I used it too freely the previous year. I have not seen a case stated of evil arising from the use of lime. As to defective fertilisation, I send you a Muscat bunch on which I was requested to try an experiment in the spring. To the upper portion, the shoulders, pollen was applied with a brush, which was also drawn down one side of the bunch and round its tip at the bottom, the other side not being touched. What do you think of this?—STEPHEN CASTLE, *Manager, West Lynn Vineyard.*

[We think the necessity for artificial fertilisation was absolute in this case. On the side of the bunch "not touched" the berries are of the size of peas, and not one stone to be found in any of them. On the other parts of the bunch the berries are good, yet somewhat variable, and as a rule, with scarcely an exception, their size is in proportion to the weight of the seeds; and, further, the berries with no seeds, or imperfect seeds, are the most shrivelled, the foot stalks of the former being dried up. Only the berries with good seeds are large and firm. Though "Proprietor" communicated a good letter on page 442, we doubt if he fully comprehended the importance of the loss of nitrogen from his Vine borders through the too free use of lime as affecting the size of his Grapes. Liquid manure is known to increase the size of Grapes materially, and the immediate effect of such applications depends almost entirely on the nitrogen they contain in the form of nitrates or ammonia, and these, as "Proprietor" is well aware, will not remain in soil that contains lime in abundance. Since writing this note Mr. Taylor's letter has come to hand and is worthy of attention. The worm test is as good as it is simple.]

## NOTES ON THE MISTLETOE.

THE Rev. F. H. Arnold contributes the following to the current number of "The Naturalists' Monthly," and as it possesses especial interest at this season, we reproduce the substance of the article:—

It has been truly observed "that the Mistletoe is a most interesting plant, whether we regard its history associations or its manner of growth." Each one of these particulars has given rise to long and learned discussions, and there is much relating to it which needs further investigation.

These notes may not be unseasonable at Christmas, when one of its uses is in especial requisition. In days of yore, as Scott, in "Marmion," reminds us:—

"England was Merry England when  
Old Christmas brought his sports again.

\* \* \* \* \*

The damsel donned her kirtle sheen,  
The hall was dressed with Holly green,  
And forth to the wood did merry men go  
To gather in the Mistletoe."

First, let us re-examine its history—especially in connection with the trees on which it grows, as a parasite. The Mistletoe, the Oak, and the Druids are associated from the most remote period of our annals. The plant itself is mentioned in the ancient Sagas, and was considered sacred to Freyn, the Saxon Venus. The derivation of the term is generally supposed to have been from the Anglo-Saxon word "Mistel-tan," but this cannot be affirmed with certainty, and, as every reader of English history knows, Pliny in the sixteenth book of his "Natural History" has given on account of the ceremonies of the Druids when they removed it annually from the Oak, about the middle of March; parts of this relation are quoted in the many school books. I shall not hesitate, however, to repeat the words of Pliny, not vouching for the accuracy of the translation, as I have not the original by me. Pliny, it may be remembered, was a contemporary of Vespasian and Titus. His statement is this:—

"The Druids hold nothing in greater veneration than the Mistletoe and the tree on which it grows, provided only that it be the Oak. They select groves of Oak trees standing by themselves, and perform no sacred ceremonies without green Oak foliage. Indeed, they firmly believe that whenever the Mistletoe grows upon the Oak it has been sent from heaven, and consider it a sign of a chosen tree. But the Mistletoe is rarely found upon the Oak. When it is discovered they collect it with very great devotion and ceremony, and especially on the sixth day of the moon. This period of the moon's age, when it has sufficient size without having attained the half of its fulness, makes the beginning of their months and years."

The grand ceremony of cutting the Mistletoe from the Oak was the New Year's Day festival of the Ancient Britons, and it was held on the sixth day of the moon, as near the 10th March as the age of the moon permitted. They lead up to the tree two white bulls, and begin by tying them by their horns to the tree. The Arch-Druid then mounts the tree and cuts the Mistletoe with a golden sickle. It is caught as it falls in a white cloth. Then they offer up the victims as a sacrifice, praying that the gift might be prosperous to those to whom it was presented. The animals were killed, cut up, and cooked; meantime prayers were offered up, hymns were sung, and the heaven-born plant, thus carefully saved from pollution by any touch of the earth, was distributed in small sprigs amongst the people, as a sacred relic for the new year, a panacea against every disease, a remedy for poisons, and a safe protection against witchcraft and the possession of the devil.

As to the virtues, real or imaginary, possessed by the Mistletoe there must be considerable doubt. There can be no question, however, that the chief virtue ascribed to Mistletoe from the Oak by the Druids was the "fructifying quality," as Taliesin has it, "or of giving fertility to all animals," as described by Pliny, and it was for this virtue, when worn as an amulet or drunk in infusion, that the sprig of Mistletoe was so anxiously sought from the hands of the Arch-Druid on the New Year's Day festival. The next point is, why did the Druids especially venerate the Oak? Was it on account of the extreme infrequency of the occurrence of the Mistletoe on that tree? This seems the most probable reason, and it is certain that in modern times such a find is of extreme rarity.

Dr. Bull has carefully collected and authenticated all the known instances of the Mistletoe growing upon the Oak. Besides those he mentions in Herefordshire, which are but two, he gives us an Oak at Badam's Court, Ledbury Park, near Chepstow; one at Burningfold Farm, near Godalming, in Surrey; another near Basingstoke; and one at Plymouth—in all only seven instances of the Mistletoe living upon the Oak in England. One or two more have since been added.

I myself have only once seen a branch of Mistletoe attached to an Oak bough. It was brought to Petworth Rectory about forty years ago from Northchapel in the Weald of Sussex, and hung up in the great hall of the rectory as a curiosity, where it long remained. As the Weald of Sussex—the Anderida of the Romans—was formerly covered with Oak, it may have been one of the chief seats of Druidical worship. It has been thought by some that this was the case with Kingley Vale, near Chichester. This abounds with Yews, many of them of extreme age, and in their midst were, and perhaps still are, some very ancient Oaks beneath which the Druids may have sacrificed. Some of the finest examples of the Mistletoe which I have observed in Sussex have been at Funtlington, on Lime trees near the house of Admiral Wallis. These have been noted by many persons. It has been also observed in great luxuriance on Limes at Versailles.

In Hampshire, according to the recently published Flora of that county, Mistletoe is not common, and in the Isle of Wight it is very rare, if not extinct. Wise, the great authority on the New Forest, says, "I have never seen it on the Oak. It is abundant on the Apple trees in the forest keeper's garden at Boldre Wood." In the British Museum Herbarium there are two specimens, one labelled "from the Oak near Winchester, 1870," and another "from an Oak in Lord Bolton's Park, at Hackwood, 1864." At Selborne, Hursley, Andover, and elsewhere in Hants it is met with chiefly on Apple trees and Thorns. In Sussex the Mistletoe is abundant in some of the larger parks, as at Parham and Cowdray, but in parts of the eastern division of the county it is rarely met with.

"In one of Colepeper's MSS. at the British Museum, in a curious notice of Sir Peter Freschville's house at Stavely, Derbyshire, is this passage:—'Heare my Lord Freschville did live, and heare grows the famous Mistletoe tree, the only Oake in England that bears Mistletoe,' and to this tree the following letter, written between 1663 and 1682, from the Countess of Danby to Mrs. Colepeper, probably refers:—

"Dear Cozen,—Pray if you have any of the mistleto of yor father's oke, oblige me so far as to send sum of it to yor. most affectionat servant, Bridget Danhy.'" Let us hope that the countess' desires were fulfilled in all respects.

Why the Mistletoe should attach itself to certain trees in preference to others is a problem not yet solved. According to a census given by Sowerby, the following is a table of the comparative frequency with which trees are prone to bear Mistletoe:—Oak 1, Sycamore 1, Acacia 1, Willow 2, Maple 3, Lime 4, Whitethorn 10, Poplar (mostly black) 20, the various kinds of Apple 25. There can be no doubt but that the favourite site of the Mistletoe is the Apple tree, and it seems to be especially attached to the order Rosaceae, since it occurs not only on the Apple but on the Pear, the American Crab, the Medlar, the Mountain Ash, the Whitebeam, as has been observed at Harting, the Whitethorn, and even on a humbler member of the family, the Dog Rose.

As regards the custom of kissing under the Mistletoe I would refer those who wish to know the origin of this to "Notes and Queries," where the subject has been fully discussed in the first volumes of the series.

In the British Flora the Mistletoe is the only representative of the order Loranthaceae. It comes next to the Dogwood, and is followed by that curious little plant, the Moschatel, one of the prettiest of the tiny flowers of the spring. Its botanical description in full would be a somewhat difficult one. A succinct account of it may be thus given. The stem is forked, with sessile intermediate heads of about five flowers. The flowers are dioecious, the barren ones with a corolla of one petal in four deep equal segments. The fertile ones with four petals, deciduous. The berries are globular, smooth, sticky, and juicy, one-celled, white, pellucid, sweet to the taste, and when boiled they make the best bird-lime, their glutinous property being formerly well known in country districts for catching small birds. It seems now almost disused, because perhaps boys, although eager to ensnare them, will not take the pains to make it. It is not so, however, with the London birdcatchers, some of whom I lately met with in the Stansted woods, artfully trying to catch unfortunate cock chaffinches. They had been very successful, and informed me that bird-limed straws were a certain method of capturing them, a stuffed chaffinch being placed above them. From the Latin name of the Mistletoe, *Viscum album*, we get the term viscid, and the missel thrush is also supposed to have been so called either as specially feeding on its berries or as being an especial propagator of the Mistletoe by carrying the berries from one tree to another. Why, however, it is thus distinguished from others of the Merulidae, most of which are very fond of berries, has not yet been satisfactorily explained.

The mode in which the Mistletoe establishes itself in the tissue of other plants is very remarkable, and has been well described by De Candolle in his excellent "Physiologie Végétale." Old botanists believed that birds feeding upon the berries, and getting their beaks surrounded with the viscid matter they contain, rubbed their beaks against the branches to get rid of it, and thus introduced the seeds to their resting-place, and in this they are probably correct. Careful botanists who have examined the process of growth in these plants from their earliest stage tell us that from whatever cause the seeds are brought in contact with the wood of the tree on which they establish themselves, they adhere by means of the glutinous substance in which they have been embedded, and which hardens into a sort of transparent glue. Then two or three days after application the tiny radicle may be seen pushing towards the support, whether it be on the under or upper surface; reaching this point it becomes enlarged and flattened. It now has the appearance of a sucker, and by degrees penetrates the bark. This operation requires some time, and is not completed until the plumule begins to be developed. By the time the young plant has a pair or two of leaves the attachment will be found tolerably firm.

In propagating the Mistletoe I have known various failures. Persons have put berries in crannies in the bark, and stopped them in with earth, and tried other methods without success. It may, however, be done in a very simple manner. A successful cultivator, a gardener, writes:—"I frequently tried incising the bark and placing the berry therein, and had as frequent failures. However, seeing one day a sparrow, after pecking at a piece of fat bacon, fly away and proceed to clean its beak by wiping it on the bark of a tree, it occurred to me that the propagation of the Mistletoe was outlined in the sparrow's performance. Accordingly, at Christmas ensuing, having some young Apple trees in my garden, I moistened the end of my thumb, and therewith cleaned

the bark under the joint of a young tree, then wiped my thumb dry, and taking a Mistletoe berry pressed it with that thumb to the cleaned portion of the bark until the berry stuck to the tree. Nothing more was done. In fifteen months, or the next spring but one, appeared the plumule, slow of growth, not increasing much the next year. In this way I have made it grow on sundry young Apple trees in my garden, and in Thorn hedges also," and in this way he says "I believe it can be propagated on many trees, but not by incision. The most successful way appears to be to remove the seeds from the berry, and then smear them on the bark of the tree." It may be mentioned that in a garden at Emsworth the seeds of the Mistletoe placed on a young Apple tree shortly after Christmas germinated, although the tree was afterwards whitewashed, and at the present time has several vigorous shoots about 3 inches long. March rather than Christmas is probably the better time to place the berries on the bark, as the seeds are then more fully matured.

The Mistletoe appears to be of slow growth, but sometimes attains large dimensions. A specimen from Brittany is mentioned as having measured 10 feet in circumference—one which grew at Ashling, near Chichester, was computed to have only grown a quarter of that size in fifteen years. A writer in the *Standard* observes:—"The chief supply of Mistletoe for the London market comes from Normandy and part of Brittany. In those provinces this parasite grows luxuriantly in the great Apple orchards. We get a little from various parts of England, but the quantity is quite insignificant compared with that obtained from the north-west of France, where indeed it is really cultivated and not left to grow by chance. Tons upon tons are conveyed across the Channel by the various lines of steamers trading with the north of France, and sent up in crates to the London markets to fetch prices from about 10s. for a small crate to about 25s. or even 30s. for a large one." Mistletoe is a somewhat tender and perishable plant as compared with Holly, which is so largely sold with it at Christmas, and the dealers in it run proportionate risks. A man may buy at auction in the market a crate, the contents of which are to outward appearance in good condition, only to find when he unpacks it either that the Mistletoe has been so knocked about as to be almost worthless, or that the middle portion consists of poor and scarcely marketable stuff—for the peasants of Normandy and Brittany are not altogether free from guile, and I am of opinion that if the London Mistletoe could be supplied from our English southern counties it would be certainly more reliable, but of this more presently.

I would here quote an account of its sale at Covent Garden Market. In Christmas week it begins between two and three o'clock in the morning, at which time it may be presumed few of us would be likely to be bidders, but at Farringdon the market is that dark, cold, raw, time it is even earlier. The Mistletoe is then sold by auction. The auctioneer, each accompanied by his clerk and a porter, is mounted on a stand and surrounded by a crowd of buyers. "Next lot," shouts the auctioneer, pointing to a crate of Mistletoe, "10s., 12s., 13s., 15s.—quickly—16s., 18s., 20s.—yours." The hammer descends, the auctioneer nods to the buyer, and the sale is completed, all but the payment of the money, of course, the whole time occupied having been less than a minute. The costermongers, retail dealers depart in the semi-darkness to vend the Mistletoe sometimes in single sprigs to hang in the hall, the sitting room, or perhaps the kitchen, to be placed there as an ornament, or placed over the head as may be.

Now if Mistletoe can be sold in London at Christmas at prices varying from 10s. to 25s. or 30s. per crate, it may be queried whether it might not be profitably cultivated at home, instead of our obtaining such large supplies from abroad. These are days not only of agricultural but of general depression, and we have need of utilising many overlooked resources. It may be asked why should we be mainly dependent on France for our supplies of Mistletoe. Why if it can be cultivated there should it not be cultivated here, in the Somerset, Sussex, and Hampshire orchards and hedges, from which crates of this valuable commodity could be so easily forwarded to town without the cost of the Channel transit. This may seem a somewhat prosaic ending to these notes on this curious but interesting plant, with all its quaint traditions, but were I to buy a sprig of Mistletoe, with its bright white glistening berries at Christmastide, I must say that I would prefer it of home growth, and not have of foreign production one of the most ancient amenities in our English folk lore, which from the times of the Druids to present day has always been a favourite with our ancestors, is still so with ourselves, and will doubtless continue to be so when "a thousand years are gone."

### THE CULTURE OF BOUVARDIAS.

THERE is no plant so useful at this time of the year for decoration either in the conservatory or intermediate house as Bouvardias, and anyone with a few old plants can readily increase them by means of cuttings. After the old plants have flowered they are placed in a cool house, and scarcely any water is given for a time. They are then pruned a little and placed into heat. Here they soon commence growth, and when the shoots are 2 or 3 inches long I take them off with a heel and dibble them into pans filled with leaf soil and silver sand; they are then plunged into a bed where there is a bottom heat of about 65°, and in a few weeks most of them will be rooted. As soon as they are rooted they are placed on a shelf in a cooler temperature for a few days; they are then placed singly in 3-inch pots, using a compost of loam, leaf soil, and sand, and are transferred to a moderately warm

house. They soon begin growing, and the tops are pinched out to make them bushy. I place them into a cooler temperature for a short time, admitting plenty of air, and by the end of June they have become quite hardy, ready to be planted out in their summer quarters. A border with a south-west aspect suits them admirably, and by the middle of September they will have four or five good shoots, and are ready to be transferred to the 6-inch pots. The result will be a profusion of flowers during the winter. Good free-flowering varieties are *Vreelandii*, white; *Dazzler*, scarlet; *Alfred Neuner*, a good double white; *President Garfield*, a double pink variety; *Hogarth*, scarlet, with large trusses; *Jasminoides*, a sweet-scented variety; and *Elegans*, a bright scarlet.—T. TEBBY.

## THE DINNER AT ANDERTON'S—IN TWO CHAPTERS.

### CHAPTER I.

LET it be explained for the information of country readers who like to be acquainted with the facts of a case that "Anderton's" means a great hotel and the loftiest building in Fleet Street. There are at the least two other tallish buildings on the same side of the renowned thoroughfare—namely, the *Daily Telegraph* and *Journal of Horticulture* offices, which together can no doubt boast of issuing the "largest circulation in the world." The dinner referred to, as may be anticipated, is that of the National Chrysanthemum Society, of which perhaps a free and modest account may be allowed to appear supplementary to the precise report that was given last week. A very correct and particular narration of the proceedings will be attempted, and if there should happen to be a slight departure from absolute accuracy in every detail it must be attributed to a lapse of memory and not to an intention to mislead. Notes could not be taken because I had no pencil, and if I had one, a shorthand report of the speeches was altogether out of my line.

It was not a grand dinner attended by the *élite* of the fashionable world, but what may be termed a useful three-and-sixpenny spread; good enough for the money, and equal to the daily fare probably of average Chrysanthemum growers. Anyhow those who were there appeared to enjoy it, including myself as one of them. There was no parson to say grace, but one exalted personage with the Star of India glittering on his breast honoured the company with his presence. Sir Guyer Hunter is an M.P. for an east end constituency, but on which side he votes I neither know nor care. The Chrysanthemum is merely a plebeian flower, or has been so far; but it is looking up and gaining aristocratic admirers, so in due time we may hope that President Sanderson may be able to call on a chaplain for the occasion for discharging a befitting duty. It is curious out of so many clerics who pay homage to the Rose that so few have fallen in love with the Chrysanthemum; but there are a few, and there will perhaps be more as time rolls on. But what has this to do with the dinner? Nothing except for noting an omission.

And since I am on this track, let me note a few more omissions. A total stranger to "Anderton's" and to nearly everybody in the great and crowded room, I yet had a very good guide, who appeared to know his way about, and to be acquainted with almost everybody. With a curiosity that is, perhaps, not unpardonable, I wanted to see what those gentlemen were like whose names were more or less familiar to me. Glancing down the toast list I whispered, "Are they all here?" Straining his neck my friend replied, "Yes, I think so, except Jones, and I don't see him." "Is Dr. Hogg here, then?" "No." "Dr. Masters?" "No." "Shirley Hibberd?" "No; big pots, you know; and the two doctors will have to be at the Horticultural Club Dinner, I expect; while 'Shirley,' I believe, doesn't dine out." "Not dine out? Why I read not long since of his eating and drinking 'real turtle' with the Lord Mayor, and telling how they make it with conger-eel; then going on with an extraordinary narration about 'Taming a Turtle,' finishing something like this: 'I will say no more at present. The story they tell about me is that through dining with the Lord Mayor he went off his chump, and talks of nothing but turtle; and it is perfectly true.' Not dining out! why, there is his own word for it." "Oh, he was only romancing; but where did you see it?" "In the 'Golden Gate,' a five-shilling Christmas book, with three shillings' worth of nonsense in it and two shillings' worth of sense. I call it the sublime and ridiculous book, and will send it to you for your trouble." "Thanks; but I can afford five shillings." "There's independence, or goodheartedness; he permits me to bother him, and will have nothing in return. So I proceed, 'Is Wynne in this great company?' 'I don't see him; busy, perhaps, or at the H. C.'" "Is he a 'big pot,' then?" "Getting on." "Good. James Douglas—is he here?" "No; he doesn't much care for the frivolities of life, I fancy, but is good company when he does come out." "John Laing?" "No; at the H. C., probably." "He is 'getting on,' then?" "Rather; but two or three of his sons are here. That's one—the dapper-looking little fellow, with the snug moustache, and he is as smart as he looks." "Well, I've found somebody at last. Can you point out William Earley?" "Earley? No; he doesn't like being out late. To see him to advantage you must be at the 'Palace' Show early in the morning." "Very well, then. George Gordon? I want to see him." "Sorry; but you won't see him to-night. He doesn't care for luncheons, dinners, and that sort of thing—rather shuns them; and I don't think anything would have tempted him here but boiled Chrysanthemum."

\* The new edition of this work, recently published by E. W. Allen, is only 2s. 6d.—Ed.



Is my friend getting tired of being tortured? His last reply has a suspicious ring about it. I have, however, done with the absentees, and cannot help feeling that with such a great meeting without them the National Chrysanthemum Society must be very strong. Another day I may perhaps say something about some members who were present, and tell a little of what I understood them to say, but being at the other end of the room may not have caught every word and sentence. But before closing this instalment I should like to know if Anderton's pay their waiters. What should you think, plain reader, if you paid 3s. 6d. for a plain though good dinner, yet not better I should think than you could get in a hundred places for the money, and "no extras?" if a waiter stooped down, and with tender obsequiousness whispered in your ear, "Could I get you a nice bit of anything more, sir?" "No thanks." "Quite sure sir, and quite satisfied?" "Quite!" "No fault to find with the waiting I hope." "N-no, but I soon shall have." "Yes, beg pardon, sir, but if you *could*"—showing a sixpence or two, as if to suggest no coppers expected. I say what should you think, and what should you do, under such circumstances? Why, probably think that the man was either not paid by his employers, or badly paid, and so, to be on the safe side, slip a bit of silver in his hand, as many did. If he had said he had nothing but what he collected it would have saved time, and he and they might have picked up more; but if the company had consisted of those "dukes, earls, lords, and barons," who drink somebody's tea, would the collecting dodge have been allowed? No! then why should it be practised on the members of the National Chrysanthemum Society? The custom is common in eating houses and second-rate taverns, but I did not know it was in operation in first-class hotels.

"It has been a splendid evening, hasn't it?" remarked one ruddy faced gardener to another as they were passing out. "Yes," was the reply, "capital, but there has been quite enough begging," and I am not sure he was alluding to the poor waiters alone when he made that remark.—A COUNTRYMAN.



At the meeting of the ROYAL HORTICULTURAL SOCIETY'S SCIENTIFIC COMMITTEE on December 13th Mr. A. H. Smee brought a flower spike of *Odontoglossum maculatum*, bearing leaves, and partly swollen like a pseudo-bulb. The usual arrest and differentiation of growth had not taken place, and the result was the production of a structure combining the characteristics of pseudo-bulb, leaf shoot, and flower stalk. Dr. Masters showed fruits of *Cydonia sinensis*. This plant was received from M. Van Volxem, in whose garden at Vilvorde the fruits had been produced in the open air. He also showed drawings of malformed flowers of *Cypripedium Sedeni* × from Messrs. Veitch and Mr. W. Bull. In one case the lip was greatly reduced in size; in the other, in addition to other changes, there were two lips placed side by side. An informal conversation took place as to the action of the Scientific Committee in the case of certain contingencies. Mr. Boscawen was strongly of opinion that under any circumstances the meetings of the Committee should be continued, and, if possible, in or in connection with the Lindley Library; and this opinion was in substance cordially and unanimously upheld by the Committee.

— A NORTHERN correspondent writes:—"The WEATHER IN SOUTH PERTHSHIRE has, during the past week, been of the most variable character, frost, thaw, snow, rain, wind in quick succession. A slight snowfall whitened the country during the night of the 17th, and on the 18th we had 9° of frost." The weather has been very similar in the south; on several days there has been a little frost in the morning followed by heavy rain in the afternoon or evening, to be again succeeded by frost and a few flakes of snow.

— THE balance sheet and statement of accounts for 1887 of the SHEFFIELD AND WEST RIDING CHRYSANTHEMUM SOCIETY has been sent to us. The receipts during the year, including a balance of 13s. from 1886, amount to £178 11s. 6d., the expenditure to £174 17s. 9d., leaving a balance in favour of the Society of £3 13s. 6d., or £3 0s. 6d. in excess of last year. At the annual meeting, held on Monday night last, it was decided that the next exhibition be held on Friday and Saturday, November 16th and 17th, 1888, so that the fixture does not clash with that of Hull, as was the case this year, possibly both shows suffering to some extent in consequence.

— ON Thursday last, December 15th, THE POTATO formed the subject of a paper read before the Manchester Horticultural Society by Mr. F. Robinson. Mr. Bruce Findlay presided, and in the course of an opening address concerning the importance of the Potato he observed: "Few persons had an adequate idea of the extent to which the Potato ministers to our necessities, and even to our luxuries; but some notion may be formed when it is stated that in 1879 we imported from the Continent 50,185 cwt. of Potato flour, 693 cwt. of Potato arrowroot, 9832 cwt. of Potato starch, and 470 cwt. of Potato starch gum, making, with 688,910 cwt. of Potatoes imported, an aggregate value of £148,500, exclusive of what is produced at home. The imports of Potatoes, of course, vary according to our own crop."

— MR. F. ROBINSON'S paper dealt at some length with the history of the Potato, the appearance of the disease and its subsequent progress. Then turning to its commercial importance he gave the following statistics:—From the official agricultural returns published last year it appears that there were then 1,364,350 acres planted with Potatoes in the United Kingdom, and of this quantity more than 799,858 acres were in Ireland. The cultivation has decreased since 1872, as in that year the land planted was a quarter of a million acres over the figures of 1886. In addition to this enormous production of our own we annually imported extensively. In 1883 our imports amounted to 257,000 tons, and in the three following years the average was 125,000 tons per year. The cultivation of the Potato in France is much more extensive, for last year there were planted 1,463,251 hectares, which was equal in extent to 3,658,128 English acres, and the total quantity of Potatoes yielded was about 41,287,764 tons. He had not been able to procure the returns for Germany, but Prussia produced in 1886 19,000,000 tons. Owing to the number of new and so-called new introductions it was impossible to state with accuracy the number of varieties at present known in commerce. New varieties of a high-class character are always required, and concurrently with their introduction and distribution those of inferior merit and most liable to disease are discarded. He estimated the number to be some 300 kinds of white and coloured varieties, divided equally between the kidney and round shape. For agricultural purposes from 12 to 14 cwt. of Potatoes are planted per acre, the crops from which vary according to the variety, state of the ground, locality, season, time for planting, and after treatment. But under good conditions Early Kidneys may be expected to produce 4 to 5 tons, Dalmahoy and Scotch Regents 6 tons, Champion, Magnum Bonum, and Maincrop 8 tons, and Imperators 8 tons per statute acre. Under very favourable circumstances, however, many instances have occurred this season where farmers have realised 12 tons, and in exceptional cases from 15 to 16 tons of Magnum Bonum and Emperor. Among the important points on which there is a difference of opinion is the question as to how long one variety will last. In the evidence given before the Royal Commission it was stated that none last longer than twenty years. This is a subject on which it appears no printed records exist, but certainly twenty years is within the mark, as the Ashleaf Kidney has been recognised as a standard early variety for the past thirty years.

— A NEW LONDON WEATHER CHART, by Mr. B. G. Jenkins F.R.A.S., has been sent to us. It is designed as a forecast of the weather during 1888, including the temperature, fluctuations of the barometer, rainfall and prevailing winds, all particulars being duly set forth as if they had occurred, indeed, according to the explanation, they have occurred, but it all happened in 1826. The author claims that "the moon not only influences the weather but is the actual cause of it, for it has a hitherto undiscovered cycle of sixty-two years, and the weather is a coincident cycle." It is an interesting theory, and can be tested by anyone who likes to check the weather as it occurs with the prognostics recorded. The charts are in two sizes, 25 inches by 10 inches and 12 inches by 5 inches, the latter printed in extremely small type, and are cheap. They are published by Mr. R. Morgan, Westow Street, Norwood, London, S.E.

— THE usual monthly meeting of the BELGIAN HORTICULTURISTS was held in Ghent recently when the following were present:—MM. V. Cuvelier, R. Desmet, E. Delaruye, F. Desbois, J. Hye, M. de Cock, L. de Smet-Duvivier, Bauda, and Rosseel, M. Ch. Spaë presiding, and M. L. Halkin of Brussels acted as Secretary. Certificates of merit were awarded for *Cattleya velutina* and *Cattleya superba* from M. L. Desmet-Duvivier; *Cypripedium Amesianum*, from M. James Bray;

Oncidium species, from MM. Vervae et Cie.; *Cypripedium Lawrenceanum*, from M. Grenier; *Cypripedium Crossianum superbum*, *Cypripedium insignis*, and *Cypripedium præstans*, from M. J. Hye. Cultural certificates were awarded for *Cypripedium Spicerianum*, var., from M. L. Spac-Vander Meulen, *Cypripedium Spicerianum*, var., *Cypripedium Sallieri*, and *Masdevallia tovarensis*, from M. J. Hye; and *Oncidium ornithorhynchum*, from M. le Cte. P. de Hemptinne. Honourable mention was accorded for *Dracena indivisa* var., from M. de Bruycker of Meirelbeke; *Reinwardtia tetragynce*, *Masdevallia bella*, *Cypripedium Dayanum splendens*, and *Cypripedium Sedeni grandiflorum*, from M. Ed. Pynaert; *Cypripedium Schlimi*, from MM. Vervae et Cie.; *Lælia Dormani*, from M. Ad. D'Haenc; and *Cypripedium Sedeni*, from MM. Vervae et Cie.

— HORTICULTURAL SUPPER IN EDINBURGH.—A horticultural supper was held on the 16th inst. in the Windsor Hotel, Edinburgh. Mr. Wm. Thomson, Clovenfords, presided, and Mr. R. Munro and Mr. A. Mackenzie acted as croupiers. There were about seventy horticulturists present. "The Magistrates and Town Council of Edinburgh" was proposed by the chair, and replied to by Councillor Hay. In proposing the toast of "Scottish Horticulture," the Chairman said if ever there was a time in the world's history when it was important that the science of cultivation should be known in all its details, it was now. It was becoming a serious thing for the nation that there was, generally speaking, no class of tenants able to make the very best of the land they held. There was, he went on to say, an opening now for young gardeners which did not exist twenty-eight years ago. He referred to the Tea planting in India. Gardeners were altogether much better off than when he was a young man. Mr. Alexander Mackenzie, in responding, said that he was often told that the present race of Scottish gardeners were not equal to that of the past. He believed they were, and that they would carry forward the triumphs of former generations, and hand them down to the coming generations. Mr. James Grieve, in a humorous speech, proposed "The Royal Caledonian Horticultural Society, the Scottish Horticultural Association, and other kindred Societies." Mr. D. P. Laird, of the Scottish Horticultural Association, who responded, said he did not see why there should not be certificates for proficiency in horticulture. The other toasts included "The Nursery and Seed Trade," "Scottish Gardeners," "The Horticultural Builders," "The Horticultural Press," "The Market Gardeners and Florists," and "The Nursery and Seed Employés."

— THE annual meeting of the WIMBLEDON HORTICULTURAL SOCIETY was held on the 14th inst. in Lecture Hall, Dr. Walker in the chair. It was stated that the total receipts were less than in 1886, yet nearly £20 more had been awarded in prizes, and there was still a balance of nearly £10 in favour of the Society. Dr. Walker and Mr. J. Lyne were re-elected Honorary Secretaries, the following being elected as members of the Committee—Messrs. Alderman, Amooore, Berridge, Bentley, Cole, Chandler, Cypher, Dale, Faulkner, Gibson, Hunt, Methven, Newell, Northover, Shcalam, Stratton, Thomson, Thornton, and Ware. It was agreed that the Society should be amalgamated with the National Chrysanthemum and National Rose Societies.

— THE KINGSTON CHRYSANTHEMUM SOCIETY held their annual meeting on Wednesday, the 14th inst., the Hon. Treasurer, Mr. J. Drewett, presiding. From the annual statement it appeared that the income of the past year amounted to £223 3s. 11d., which was made up by the following items:—Balance brought forward from previous year, £40 2s. 5d.; subscriptions received, £110 18s.; money taken at doors—first day, £43 17s. 9d., second day, £25 1s. 3d., total, £68 19s.; sale of tickets, £3 4s. 6d. The expenditure reached £215 5s. 7d., the chief item being £120 16s. for the Society's prizes. There was a balance in hand of £7 18s. 4d. The falling off in the receipts was due to the exceedingly wet weather on the second day of the Show. Mr. T. Jackson resigned his post as Hon. Secretary, and was accorded a hearty unanimous vote of thanks for the services he had rendered. Mr. Woodgate was elected Hon. Secretary and the following as members of the Committee—Messrs. Attrill, Bates, Child, Cawte, Hardy, Lyne, Macpherson, Orchard, Puttock, Shepherd, Slade, Watson, Furze, and Dr. Walker. The Show next year will be held on November 6th and 7th.

— ON Wednesday, the 14th inst., THE ANCIENT SOCIETY OF YORK FLORISTS held their annual dinner at the "White Swan Inn." The Lord Mayor of York, Mr. Alderman Rymer, occupied the chair,

and there were also present the City Sheriff, Mr. S. Border; Mr. Councillor Oakley, Mr. Councillor Wragge, Mr. T. E. Abbey, Mr. Marchant, Mr. Walton, Mr. Cowper, Mr. Ogden, Mr. White, Mr. J. Hume, Mr. Hebblethwaite, Mr. Carr, Mr. Fielden, Mr. Hampson, Mr. W. B. Dyson, Mr. Key, Mr. Lazenby, Hon. Sec.; and others. Letters had been received from Aldermen Hornby and Wright, Councillors Matthews, Dale, Turner, and Lindberg, and Major Bairstow, Messrs. J. N. Rowntree, W. W. Hargrove, J. T. Hingston, J. Brown, and T. Coulson regretting their inability to be present. The usual toasts were proposed and responded to, and the Chairman said, in the course of a short speech, that "He was sure the Florists' Society was doing a great work in the city of York. He remembered when they had their Horticultural Society, which unfortunately died a natural death. That Society had existed considerably over 100 years, and had, in some obscurity at one time, carried on its work quietly and unostentatiously. He was pleased to think it was now coming more to the front, making greater headway, and he was glad to say was never in a more prosperous condition than at the present time. They must all be delighted with flowers, and those who had not the faculty for training and cultivating them envied those who knew how to grow those pretty flowers known as 'florists' flowers.' He believed in Chrysanthemums, for, as the Irishman said, he admired the moon because it came out and shed its light when all was dark, so Chrysanthemums came out in winter when all other flowers 'had faded and gone,' and shed their beauty all around. He rejoiced that he had been one who assisted in the establishment of the Chrysanthemum Show. He had been pleased to see how it had grown, and he knew it was now looked forward to with interest by the citizens, and as long as they acted bravely and nobly, and with some little enterprise, he was sure success would crown their efforts in the future as in the past."

— AURICULA PAGE'S CHAMPION.—Mr. W. Kilgour, Blair Drummond, writes:—"A friend to whose opinion I am always inclined to defer informs me that what I have as this variety is not correct. He founds this mainly upon Sweet's "Florists' Guide," where Champion is figured and described. Sweet gives the ground as a velvety black, and my informant says that a plant which bloomed with himself, but which he subsequently lost, corresponded to that description. Every other authority, past and present, that I can meet with gives the body colour as more or less red, and in the bloom of my plants the red is quite decided. The colour may deepen as the plants get stronger, but certainly not to black. Inquiries tend to convince me that I have what was over thirty years ago grown in Scotland as Champion. One eminent florist whose collection of Auriculas was then well known exhibited beyond question as such the flower I have, and I can as readily doubt Sweet's infallibility as believe that he and others should be cultivating and showing some other plant as Champion within a few years after the latter was sent out. I am anxious to know whether or not I have the true variety, and perhaps some of the readers of the Journal can help me."

— THE RICHMOND HORTICULTURAL SOCIETY.—At the annual meeting of this Society held recently, the report of the year was read, the financial condition being satisfactory, as there is a balance to the credit of the Society of £19 4s. 2d., the total amount expended in prizes and medals being £261 0s. 6d. At the summer show eight silver Jubilee medals were offered for the most meritorious exhibits in the different sections, and seven were awarded to the following:—H. Little, Esq., East Twickenham; Messrs. Hooper & Co., Twickenham; Mr. W. Bates, gardener to Mrs. Meek, Poulett Lodge, Twickenham; Mr. J. Coombs, Sheen House Gardens; Mrs. Chard, Brunswick Nursery, Stoke Newington; Mr. H. Down, Isleworth; and Mr. G. Filsell, Hatfield House Gardens, Twickenham. These medals are large, handsome, and valuable productions, and were presented to the winners by Sir H. Whittaker Ellis. Hearty votes of thanks were accorded to the courteous and respected Hon. Secretary, Mr. J. H. Ford, and other officials for their services during the year.

— A "LOCAL ROSARIAN" writes as follows respecting the NATIONAL ROSE SOCIETY AT RICHMOND:—"I was present recently at a meeting of the National Rose Society, when the Hon. Secretary stated that it had been proposed to hold one of the National Society's shows in Richmond, and he had twice written to Mr. Ford respecting it, but failing to obtain a reply, other arrangements were made. However, after the lapse of three weeks, he received a letter expressing willingness to receive the National Society, but it was then too late. I believe that

many persons would have been glad to see a really representative exhibition in Richmond, and there would have been no difficulty in making it a great success. It is therefore unfortunate that this rather strange delay should have occurred."

— THE subject for discussion at the last meeting of the members of the WAKEFIELD PAXTON SOCIETY held at Councillor Lupton's, the Saw Hotel, was "The Apple," and it was introduced by Mr. J. G. Brown, gardener to Mr. J. B. Charlesworth, J.P., of Hatfield Hall. Councillor Milnes presided, and Mr. H. Oxley was in the vice-chair. There was a good attendance of the members. A capital collection of dessert and baking Apples was exhibited, and Mr. George Perkin, of York Street, exhibited a specimen of the "Winter-Moth," which commits great ravages amongst Apple trees. Mr. Brown, who is one of the oldest members of the Society and a Kentish man, has devoted considerable attention to the growth of Apples for many years past, and he read a capital paper on the subject. He pointed out the varieties of Apples which he had found from experience can be most successfully grown in this part of the country, and he advocated the growth of Apples on an extensive scale by farmers and market gardeners. A long and interesting discussion took place on the subject, in which several of the speakers complained that the smoke nuisance considerably interferes with the fruit growing in this locality. Mr. W. Pye, the postmaster in very complimentary terms, proposed a vote of thanks to Mr. Brown for his paper, and the motion was seconded by Mr. G. Gill, of Eastmoor and supported by Mr. T. Garnett.

#### DECEMBER NOTES AT UPPER HOLLOWAY.

THE November fogs which so severely try the skill of cultivators in the metropolitan district, and which play such havoc with flowers of nearly all kinds, seem to lose much of their poisonous influence at Upper Holloway, probably owing to its elevated position, and in consequence Mr. B. S. Williams is enabled to provide quite a surprising display of Orchids for the time of year. Within the present month and up to this date nearly 700 spikes and single flowers have expanded, and there are hundreds more to come amongst *Laelias*, *Vandas*, *Cattleyas*, and *Cypripediums*. In each of the numerous houses devoted to Orchids is a group of plants in flower, besides the usual stock of sturdy healthy specimens that reserve their attractions until a later period. There is an unusual number of *Vandas* in flower for this time of year, and it is probably due to the exceptionally hot season having induced an early resting period. Whatever the cause, they look extremely well, and are producing fine highly coloured flowers. The plants of all genera throughout the collections are distinguished by their healthy appearance, the leaves of the *Cattleyas*, for instance, being as firm and as well developed as could be wished, scores of sheaths being now produced. This satisfactory condition is mainly due to two items in their culture; first, they are never weakened by excessive heat or undue shading, and second, they are kept thoroughly clean. Practical growers will fully appreciate the importance of these two matters, and the latter especially, for, however correct the treatment may be in other respects, if plants are infested with insects they cannot thrive. As an exterminator of insects of all kinds Mr. Williams now relies exclusively upon the *Thanatophore*, which is employed in all the houses, including those containing Orchids in flower, or the most delicate Ferns, without the slightest injury to anything except the insects. Using the larger size with strong tobacco juice, it is found to be more economical and effectual than fumigating with tobacco or tobacco paper, and the great advantage is that it can be employed where Orchids are in flower, a time at which they are especially liable to become infested with insects.

*Cypripediums* are very numerous amongst the Orchids in flower, and a choice collection is now included of all the most beautiful and valuable hybrids hitherto obtained. Mr. Harry Williams has made these an especial study, and has undertaken several interesting experiments in hybridising that may be expected to bring some good results. In several cases pods of seed are ripening that have been obtained by crosses between widely separated species, and if a combination of their characters has been effected something of a very unusual kind must be looked for. Of the varieties in flower the following are noteworthy:—*C. Sanderianum*, *C. microchilum*, *C. ceananthum* and its variety *superbum*, *C. Dauthieri*, *C. porphyreum*, *C. Ashburtoniae* and its variety *expansum* with a very broad dorsal sepal, *C. Sallieri*, the large and yellowish form of the *C. insigne* type; *C. Fitcheanum*, a novelty of the *C. Hookeri* type, but quite distinct; the magnificent *C. Morganiae* has three superb flowers; *C. chloroneurum* is very distinct, with the dorsal sepal quite a bright green; *C. cardinale*, free and useful; *C. calurum*, *C. meira*, *C. Lecanum*, *C. calophyllum*, and *C. superbiens*, the last named flowering out of its usual season.

The other houses contain plants in flower of *Cypripedium Harrisianum*, a very dark variety with five large polished flowers; the useful and free *C. Spicerianum*, *C. insigne Maulci*, still the best of the type, a good plant with eleven flowers; *C. biflorum*, a neat and pretty flower, the dorsal sepal crimson tinted with a white margin; *C. venustum*, *C.*

*Crossianum*, *C. Sedeni*, and another of the insigne family, *C. punctatum-violaceum*, which in some is preferred to *Maulci*, and is largely grown for a winter supply of flowers. Although there is such a strong prevailing family likeness in the *Cypripediums*, the species are also very distinct from each other, and perhaps more readily recognised than most other members of large genera. They are also nearly all easily grown, and comprise so many suitable for winter flowering that their rapidly extending popularity is readily understood.

The miscellaneous Orchids in the warm houses include the following—*Calanthes Veitchi* and *vestita*, with several varieties of the latter, and the valued *C. Turneri* is also expanding. The graceful arching spikes of these plants arranged with other Orchids and Ferns have a graceful effect, and their value for grouping cannot be too highly estimated. *Vandas tricolor*, *insignis*, *suavis*, and the Glen variety of *V. tricolor* are in flower, the last named a light form with a crimson lip and bright spots. A plant of *Catasetum Bungei* in a 48-sized pot has two spikes of seven large wax-like flowers each, the broad concave lip being very prominent. This fine *Catasetum* was figured in this Journal last December, and the plant has since become well known, as it is one of the best of the species from a horticultural point of view, flowering frequently and growing strongly. A particularly large specimen of *Cymbidium eburneum* has twenty-six spikes showing, and will present a fine appearance later in the season; *C. Lowianum* is also showing flower spikes freely. *Miltonia Morelliana*, Callender's variety, is an unusually dark form, and has been in flower for nearly three months. A beautiful dark variety of *Phalænopsis Sanderiana* with crimson tinted flowers is notable.

*Dendrobium superbiens* and *Goldieanum* are nearly always in flower near the *Vanda Hookeri* corner of a small stove, and there also is *Dendrobium bigibbum* with its variety *album*, which produces its flowers white in their early stages, becoming tinted as they grow older. In the same house is a small plant of *Pleurothallis lamphrophylla*, a species rarely seen, and the genus altogether is seldom represented in gardens, though such as this would well deserve attention. It has upright spikes of small yellowish semi-transparent flowers, and possessing a peculiarly agreeable though slight spicy fragrance. Some of these small flowered Orchids are undeservedly neglected in private collections, and this *Pleurothallis* reminded us of the graceful *Liparis pendula*, so well represented in the collection at Waddon House, Croydon. Quite a forest of spikes of *Laelia anceps* are expanding their bright flowers, and will afford a rich Christmas display. *Trichopilia tortilis*, *Cattleya Chocoensis* *alba* are flowering. Of the pretty little purple and white *Leptotes bicolor* there is a dozen plants with the flowers opening. *Masdevallia tovarensis*, *Pilumna nobilis*, *Lycaste Skinneri* *alba*, *Trichosma suavis*, *Sophronitis grandiflora*, *Cattleya Percivaliana*, *Epidendrum ciliare*, *Cattleya Loddigesii*, *Brassia Lawrenceana*, *Zygopetalum Clayi*, *Odontoglossum Insleayi* *leopardinum*, and *Oncidium jancirensis* are only a few amongst many good plants.

In the cool houses are hundreds of fine *Odontoglossums* advancing into flower, including some charming varieties of *O. crispum*, *O. constrictum*, with its larger and better form *O. Sanderianum*, are attractive, the distinct and elegant *O. ramosissimum* having a place in the same house. The flowers are somewhat like a small *cirrhosum* about 2½ inches across, the sepals and petals narrow, much undulated and curled, white, with pale violet spots on the lower half and base of the lip, which has a white crest in the centre. The panicle had four branches of seventeen flowers. *O. Ehrenbergi* is like a miniature *O. Rossi*, not very showy, but neat. *Oncidium Forbesii*, *O. albo-violaceum*, the exquisite *Restrepia antennifera*, and several other Orchids are also flowering in this department, which includes a large stock of select *Masdevallias*.

The other houses are stored with extensive collections of stove and greenhouse flowering plants and Ferns, the latter looking particularly well for such a dull period as the present. Pitcher Plants, Crotons, and *Dracaenas* are well represented in their respective departments, besides Heaths, hardwooded plants, *Cyclamens*, and *Primulas*. All are well grown, and this alone would satisfy such a practical and experienced cultivator as the genial proprietor, Mr. B. S. Williams.

#### NEW CHRYSANTHEMUMS.

THE demand for novelties amongst *Chrysanthemums* has been great in recent years, and the supply has increased proportionately, the scores of so-called new varieties annually sent out by continental firms rendering Committees, such as those of the Royal Horticultural and the National *Chrysanthemum* Societies, obvious necessities. If no checks were imposed on the distribution of these very abundant novelties, it is to be feared that many growers would soon become disgusted with purchasing inferior varieties, or those that are merely synonymous with older forms. Some of the French catalogues are interesting studies, and the profuse manner with which adjectives are employed shows that describing plants for sale is quite an art, in which British nurserymen cannot pretend to equal their continental neighbours. A description that in a French list occupies 2 inches of small type we find compressed in an English specialist's catalogue to a single line or less. Some amateurs have tried procuring the novelties direct from the foreign raisers, but how hazardous such an investment may be has been amply proved this season. For example, out of 100 varieties purchased for trial by such firms as Messrs. Davis & Jones, Messrs. Cannell



and Sons, Mr. G. Stevens, Messrs. Laing & Sons, Mr. Wm. Holmes, and Messrs. J. Veitch & Sons, scarcely a dozen have been found sufficiently distinct or meritorious to obtain certificates or be recommended for general cultivation. Another year's period of probation may, it is true, develop better characters in some of the unsatisfactory ones, but the evidence is indubitable that much recklessness is displayed in sending out novelties, the raisers not being able to perceive that they will certainly spoil their business. In the case of the Chrysanthemum, as with nearly every other plant, when a promising novelty is obtained it is increased as rapidly as possible, with the result that it probably disappoints many growers in the succeeding year, falling short of the characters it possessed when first exhibited and certificated. Perhaps in some respects the Chrysanthemum is more liable to suffer in this way

care with which they are selected and proved before submitting them to the public. Knowing the value, too, of distinct sport from standard varieties, both incurved and Japanese, cultivators apparently watch more closely for them, as the number sent to Kensington and Westminster has increased in the past year or two, though the character of the season, no doubt, has something to do with this. Another mode of adding to the number of novelties in our collections—namely, importing them direct from Japan or China, has, however, hitherto been taken advantage of to a comparatively small extent. It is now about twenty-seven years since Mr. Robert Fortune succeeded in introducing the first supply on Japanese varieties, and since then, until last season, with the exception of the interesting importation by Messrs. J. Veitch in 1881, comprising the well-known Comte de Germiny and Thunberg,

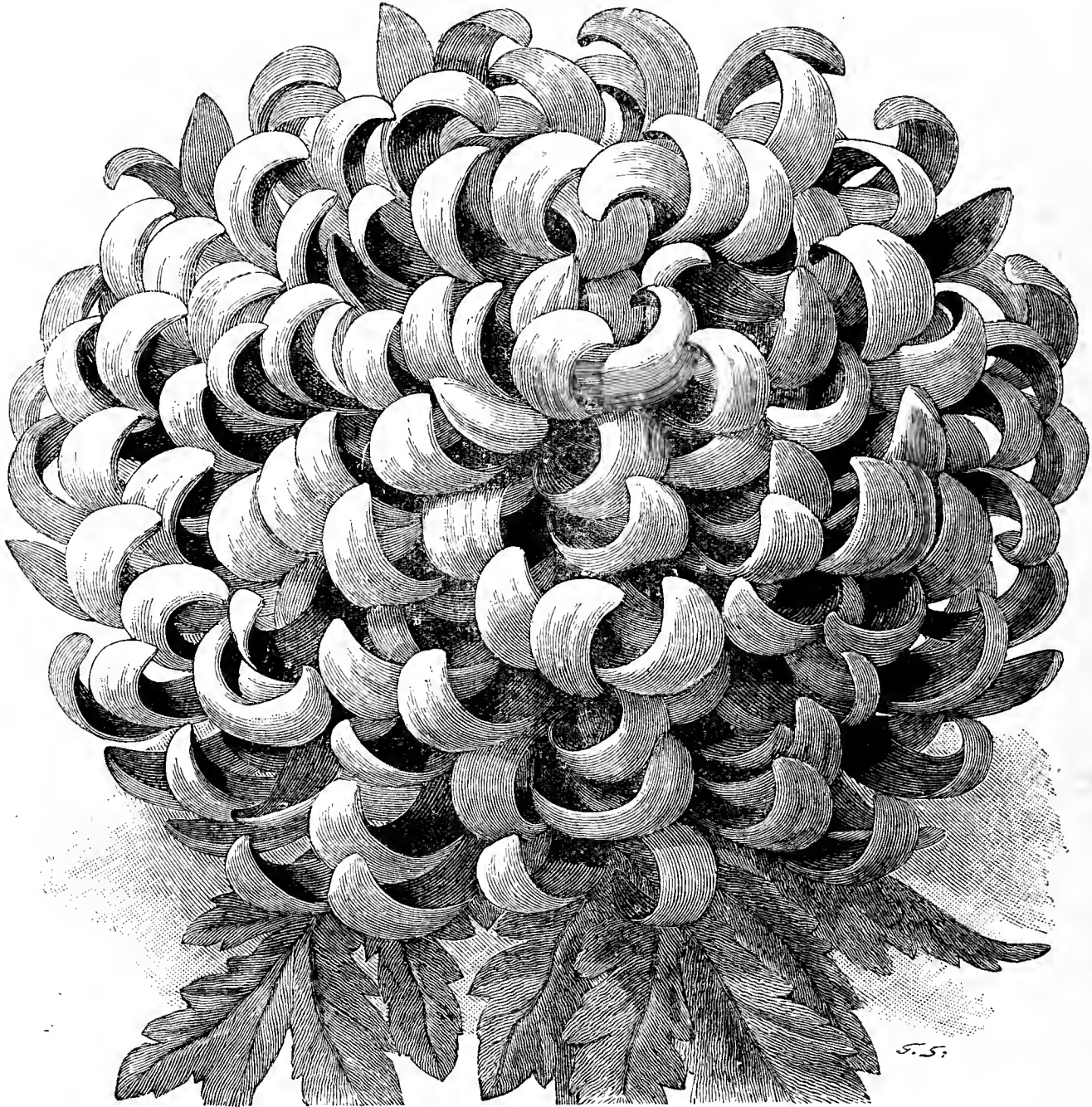

FIG. 63.—CHRYSANTHEMUM EDWIN MOLYNEUX.

than most other plants, for it is a quick-growing softwooded plant, that in moderate heat can be increased very rapidly, but forcing the growth has a weakening effect, and strong plants cannot be expected from weak attenuated cuttings. It must also be remembered that in sending out a new Chrysanthemum a nurseryman must depend almost exclusively upon his first year's sale, the next season it will be so abundant as to be of little value from a trade point of view. A consideration of such matters should make purchasers endeavour to meet any expected defects by closer attention and better culture, and much can be done in the earlier stages to avoid unsatisfactory results.

Home-raised seedlings from imported seed have become much more numerous amongst the Japanese than formerly, and the high position some of these have obtained is due chiefly to the

scarcely anything has been done in that direction. It might be expected from the great length of time the Chrysanthemum has been cultivated in China and Japan, the popularity it has enjoyed, and the attention the natives give to flowers, that the collections would comprise many remarkable varieties, and that additions would be frequently made to their numbers. It has even been placed on record that there is, or was, a blue-flowered Chrysanthemum in the Celestial Empire, and that it is figured occasionally on old china. We cannot, however, obtain any evidence of its present existence, and travellers in China have searched in vain for this treasure. Nor have I been successful in finding a representation of it as stated, either in museums or private collections, and after all we must allow artists, like poets, some licence. We have, however, a "blue" Chinese Primula, why not a Chrysanthemum of similar

tint? If some fortunate importer of varieties from the far east should discover it in his collection one November morning he might safely anticipate an extensive demand.

Last year it appears that consignments of Japanese varieties were received in England by two firms, and Messrs. Cannell & Sons, Swanley, were enabled to announce nine novelties, besides six of

broad florets,  $1\frac{1}{4}$  inch across in some cases; the leaf also is broader, with a shorter stalk, the blade running down nearly to the juncture with the stem. Mr. H. Cannell (fig. 64) is a handsome variety of a soft golden yellow colour, in the style of Thunberg, and with the florets curving rather more spirally than is shown in the woodcut (kindly lent by Messrs. Cannell & Sons) which is otherwise a



FIG. 64.—CHRYSANTHEMUM MR. H. CANNELL.

their own raising. Of the former—viz., Mrs. H. Cannell, Edwin Molyneux, Mr. C. Orchard, Mr. H. Cannell, Lady Lawrence, Lady Emily, Mr. Addison, Mr. H. Wellam, and Shirley Hibberd, the five first have proved to be exceptionally fine varieties, distinct, and grand additions to the list of exhibition Japanese. That such a large proportion of first-rate novelties should be obtained from so small a number of introductions ought to encourage further efforts to procure more from the same source. Two of the best of these are Mrs. H. Cannell and Lady Lawrence, both white, but readily distinguished, and capital for exhibition purposes, owing to their size and substance. Mrs. Cannell has a large deep bloom, with broad incurving florets, pure white, the habit moderately strong; the leaves narrow, deeply and evenly cut, and narrowed at the base into the leafstalk. Lady Lawrence is clear white, with very

faithful representation. Edwin Molyneux (fig. 63, also lent by the same firm) is a remarkably distinct and effective variety, with broad florets, slightly incurving at the tips, golden bronze on the lower surface, and an intensely rich crimson on the upper surface. When well grown this is a magnificent variety, and several good blooms of it have been shown this season. Mr. C. Orchard is of the Comte de Germiny style, with reddish crimson florets and a pale bronze reverse. Under good treatment it produces substantial and handsome blooms. These have been certificated at several shows, and are the best of the imported varieties, though probably another season's trial may improve the others.

The varieties raised at Swanley—namely, Lady Cave, Mrs. L. Castle, Mrs. B. Wynne, Mr. Matthew, Arthur Wood, and C. L. Teesdale, are mostly small Japanese, neat, but not so well adapted



for exhibition as the preceding. The three first are the best, and Lady Cave has been commended by the National Chrysanthemum Society. It has compact, medium-sized, white blooms, with fluted recurving florets, the other two being distinct shades of delicate pink, and have been included in several silver medal collections this season.—LEWIS CASTLE.

(To be continued.)

### ROYAL HORTICULTURAL SOCIETY.

#### DONATIONS AND SUBSCRIPTIONS.

THE following donations and subscriptions have been promised or sent in answer to the circular appeal, dated December 9th, for funds to enable the Society to establish itself in another home on removal from South Kensington:—

First List.	Donations.			Annual Subscription		
	£	s.	d.	£	s.	d.
Smith, Charles H. ... ..				2	2	0
Parker, Frank R.... ..				2	2	0
Balderson, H. ... ..				2	2	0
Philmore, Charles B. ... ..	10	0	0	5	5	0
Daniel, Miss E. ... ..	5	0	0	2	2	0
Cheal & Sons, J. ... ..	5	5	0			
Cheal, Joseph ... ..				2	2	0
Cheal, Alexander... ..				2	2	0
Ballard, Mrs. ... ..				2	2	0
Hodgson, T. T. ... ..				2	2	0
Bunyard, George... ..	5	5	0	2	2	0
Beale, Lionel ... ..				2	2	0
Easton, Arthur H. ... ..	1	0	0	2	2	0
Wells, H. C. ... ..				2	2	0
Gordon, John ... ..	2	2	0	2	2	0
Colebrook, John ... ..	5	5	0	2	2	0
Wheeler, A. C. ... ..				2	2	0
Wilson, G. F., F.R.S., ... ..	50	0	0			
Lewis, Arthur J.... ..				2	2	0
Townshend, H. ... ..				2	2	0
Bartlett, John E.... ..	10	10	0	2	2	0
Onley, O. Savile ... ..	1	1	0	2	2	0
Terry, Captain Courtney F. ... ..				2	2	0
Terry, Mrs. Courtney F. ... ..				2	2	0
Harrison, Capt. J. N. ... ..	2	2	0			
Ducie, Earl of ... ..	50	0	0	4	4	0
Vaizey, J. R. ... ..				2	2	0
Hayes, John ... ..	1	1	0	2	2	0
Finn, Alex. ... ..				2	2	0
Knighton, F. ... ..				2	2	0
Ebury, Lord ... ..				4	4	0
Mawley, Edward ... ..	1	1	0	2	2	0
Maxwell, Wellwood H.... ..				2	2	0
Schroder, Baron ... ..	200	0	0	4	4	0
Lawrence, Sir Trevor ... ..	200	0	0	2	2	0
Loder, E. G. ... ..	100	0	0	2	2	0
Lee, Wm. (£100 in instalments) ... ..	100	0	0	2	2	0
Courtauld, S. ... ..	50	0	0	2	2	0
Rothschild, Baron F. ... ..	50	0	0	2	2	0
Veitch, Harry J. (first donation) ... ..	50	0	0			
Grimshaw, J. Stanfield ... ..	3	3	0	2	2	0
Lancaster, Arthur H. ... ..				2	2	0
Ord, Mrs. Blakett ... ..				2	2	0
Streatfield, Mrs. F. ... ..				2	2	0
Pollett, H. M. ... ..	10	10	0	2	2	0
Dawnay, Hon. Payan ... ..	10	0	0	2	2	0
Hanbury, Edmund S. ... ..				2	2	0
Adams, Chas. F. ... ..				2	2	0
Lee, Mrs. S. A. ... ..	50	0	0	2	2	0
Pearson, Henry I. ... ..	20	0	0	2	2	0
Ames-Lyde, Mrs. ... ..	5	0	0	4	4	0
Leonard, H. S. ... ..				2	2	0
Cotton, Rt. Hon. Sir H. ... ..	2	2	0	2	2	0
Cundy, Charles ... ..				2	2	0
Swinburne, Miss ... ..	15	0	0	2	2	0
Roupell, W. ... ..				4	4	0
Lile, John H. ... ..				2	2	0
Bradshaw, R. ... ..				2	2	0
Wood & Son, W.... ..				2	2	0
Gledstanes, Francis G. ... ..	1	1	0	2	2	0
Jupp, Mrs. Geo. H. ... ..				2	2	0
Jupp, Mr. Geo. H. ... ..				2	2	0
Pearse, Major-Gen., J. L. ... ..				2	2	0
Cousins, C. W. ... ..				2	2	0
Brickwell, S. J. ... ..	2	2	0	2	2	0
Ford, Sidney ... ..				2	2	0
Warren, John ... ..				2	2	0
Matthews, John ... ..				2	2	0
	£1018	10	0	£148	1	0

#### THE SOCIETY'S CHARTER.

THE following is the text of the solicitors' letter referred to in the report last week, sent in reply to the inquiry of Sir Trevor Lawrence

respecting the power of the Society to surrender its charter or to obtain a new one.

13, Suffolk Street, Pall Mall East, S.W.,  
12th December, 1887.

DEAR SIR TREVOR,—

We have perused the copy of the Royal Horticultural Society's new charter left with us on Friday, and in reply to the questions submitted to us we beg to say:—

1, That the Royal Horticultural Society could surrender their charter provided the Crown be prepared to accept a surrender, but this the Crown would not be likely to do unless upon the unanimous wish of all the members, and on being satisfied that all the Society's liabilities had been discharged.

Obviously the surrender of the present charter would put an end to the Society, but as a matter of fact there is no case of a surrender pure and simple otherwise than by the grant of a new or supplemental charter, and except for the latter purpose there could be no object in surrendering the present charter, as there is no individual liability under it, and it would be sufficient to allow it to lapse. A new or supplemental charter would not necessarily extinguish the original charter. The present Society has already had a new charter in addition to its original charter.

2, The present charter cannot be varied or amended otherwise than by a new or supplemental charter. The latter is obtainable by petition to the Privy Council, showing the grounds for variation or amendment, accompanied in practice by a draft of the new charter desired. This application is then advertised by the Privy Council and referred to a Committee, who will hear any objections against the proposed new charter on the part of any of the members of the Society or otherwise.

3, It would take from four to six months at least to obtain a new charter, and the cost, as far as we can judge, would be about (certainly not much less than) £200, and in case of opposition the expense might of course be increased.

4, There is no power under the present charter to dissolve the Society, but under a new charter power of dissolution could, and should, no doubt, be obtained. The present charter gives no power to dispose of the Society's property, and such power could and should be obtained by the new charter.

A fresh Society or Association could be formed under the Companies' Act, 1867, and under the license of the Board of Trade, but this Association could not take over the property and undertaking of the present Society, the latter having no power under their present charter to make such a transfer.

Upon the whole, therefore, it seems that a new charter is the only feasible mode of reconstituting the Society.—We are, dear Sir Trevor, yours faithfully,

(Signed) GARRARD, JAMES, AND WOLFE.

Sir Trevor Lawrence, Bart., M.P.,

President of the Royal Horticultural Society.

#### REMODELLING THE SOCIETY.

SEVERAL persons with whom I have conversed are of opinion that the time has arrived for infusing into the Council a more practical and business element, pointing out as evidence of the necessity that the special meeting for which such elaborate preparations were made was not known by its promoters to be illegal when the summonses were issued and the appeal was printed for circulation. The President could not do otherwise than pass the matter off lightly, but he would have been in a much stronger position if he had not been under the necessity of making an explanation on the subject.

Another circumstance appears to have been found out at the last moment that ought to have been known before—namely, that a Royal charter cannot be cast aside so easily as was suggested in paragraph 5 of the appeal, which also informs us that a charter is not considered requisite. This is democracy with a vengeance, and, so far as can be gathered from the report, the suggestions were not in accordance with the views of the meeting.

It would seem that about all that a new charter, or a supplementary charter, is wanted for is to grant power for increasing the number of the Council, and this is to be purchased at a cost of £200. As to old laws that are obsolete, what harm can they do? The Council has power to make bye-laws to meet altered circumstances. Would it not be well to see what can be done by searching inquiry and close investigation under the present charter before indulging in the expenditure of the amount named, and perhaps more? Sir Trevor Lawrence said the practice of the past has been to spend the "savings" as fast as they could when there were any, and when they had no money to get into debt. There appears some danger of a continuation of this, and incurring the penalty of £200 and six months.

Is it not worth a little consideration as to the quality of the Council being open to improvement? Surely fifteen competent, earnest, representative persons can be found to conduct the affairs of the Society. The number of members of the Cabinet is not greater than that for guiding the helm of the State. Until a mixed Council of amateurs of good social position and scientific attainments, with trade representatives, provincial and metropolitan, and a due proportion of selected gardeners, has been tried, where is the proof that an increase in numbers is so urgent as to warrant the expenditure of the large sum named, with six months of waiting, and possibly much more?

It is announced that a committee has been appointed to consider various matters, and to advise thereon. Cannot special committees be



appointed at any time to consult on special subjects? If, as is stated by the Council, that reorganisation is desirable "on a more popular basis," or, as Mr. Wilks remarked, to suit the "democratic sympathies of the present day," how is that in the very first organisation formed no gardeners are admitted? The Committee that was nominated at the meeting consists of five amateurs, two nurserymen, two editors, and one horticultural builder. No fault is found with them or any one of them; but at least three gardeners who are Fellows should be added to make it fairly representative on a "popular" basis. It may be said a committee of thirteen is too large for working. What, then, becomes of the allegation that a council of fifteen is too small? Mr. James Douglas is a Fellow of the Society, I think; why could not he be put on? And no doubt there are other gardeners of the committees who are Fellows, and if there are not there ought to be. It is a question of fellowship, or membership, ought not to be a necessary qualification for a seat at the tables. If all the committeemen had power to vote, a good Council on a more popular basis would soon be chosen.

The Council attach great importance to the committee meetings, also to the fortnightly "shows." The meetings are important, and should be confined to matters of a strictly scientific, horticultural, and educational character; but most of the shows have been shams—drains on the Society's resources, because practically no visitors paid to see them. A basis of action, founded on a definite principle, is needed in respect to these meetings.

The "School of Gardening idea" is tempting on the face of it; but unless extreme care is taken in founding it (if it be founded), and especially in respect to admissions, it will prove a delusion and a snare. Chiswick cannot be made a gardener manufactory, for it lacks, and is likely to lack, many highly important essentials. There are numbers of far better "schools" in existence, and to rush a lot of "pupils" through Chiswick, and foist them on the world as gardeners, would do much more harm than good. A practical and representative Council may be trusted, however, to deal with this notion, if it ever emerges from the visionary state.

As to City rooms, they are no doubt desirable, and should be provided, subject to one important proviso—namely, that money is in hand before obligations are incurred. And in the meantime, is not Chiswick the safest and surest resting-place and base for conducting operations?—  
A FELLOW.

[It may be explained that the meeting referred to was only informal because it was not called by the Council officially assembled, and that the committee proposed by Dr. Masters, and adopted by the meeting, did not emanate from the Council.]

#### TRIALS AT CHISWICK.

FINAL PROOF.—In Mr. Shirley Hibberd's speech at the Royal Horticultural Society's meeting last Tuesday afternoon, occurs the following: "Chiswick should be a place of final proof only." "Every person sending to Chiswick should be charged, thereby making an honest income for the Society." The being "charged" for sending to Chiswick a variety for "final proof" will be valueless, unless they also greatly alter the "Chiswick trial routine" from what it was formerly. An instance occurs to my mind, it has frequently occurred, and will continue to do so as long as I have a memory of the "final proof" at Chiswick regarding a seedling Potato I induced a friend to send. This seedling, after having been raised from systematical crosses, was grown for four years and then submitted to the Chiswick authorities for "final proof." Their "final proof" set it down as synonymous with some other variety just then rather popular, and yet the cross had been made six years before; and more, the said variety though thus condemned at Chiswick is now where known and grown proven (tons of it) to be as distinct from its synonym as anyone could wish. So much for "Chiswick final proof gratis." How the "proof when charged for" will work out does not trouble me much. I should think it about the last place to send to under such conditions. I will only add one thing—the Chiswick trial result to the raiser of the Potato under mention—he never tried to raise another after such discouraging "proof."—Q.

#### PLANT NAMES.

[A paper read at a meeting of the "Chiswick Gardeners' Mutual Improvement Association," on December 21st, 1887. By F. W. Burbidge, F.L.S., M.B.I.A., Curator Trin. Coll. Botanical Gardens, Dublin; formerly of the R.H.S. Gardens, Chiswick; and also of the Royal Gardens, Kew.]

"What's in a name? That which we call a Rose  
By any other name would smell as sweet."  
—(Shakespeare, "Romeo and Juliet," Act ii., Sc. 2)

"A name should be a lighthouse, and not a dark lantern."

IT is nearly twenty years ago since I enjoyed the privilege that some of you here to-night can claim—viz., that of work and of study in the Chiswick Garden of the Royal Horticultural Society. I believe at that time the garden was something like thirty acres in extent, having a richly stored orchard, a well-stocked arboretum, a delightfully interesting wilderness-belt or "wild garden," richly furnished fruit and plant houses, and a staff of well-versed officials, of whom only Mr. A. F. Barron, Mr. Douglas Dick, and perhaps a very few employes now remain. Those were the last of the palmy days of a garden historical and of world-wide interest. Amongst other visitors to the garden in those times came Robert Fortune, formerly the Society's plant collector and traveller in China; R. Thompson, late foreman of the fruit department, and the original author of that valuable text-book, rightly entitled the "Gardeners' Assistant," the second edition of which work

should be in every gardener's book-case. The late Mr. T. Moore, Dr. Hogg, and the great fungologist, the Rev. M. J. Berkeley, Lieut.-Colonel Trevor Clarke, and many others were also there on all council days, and we, who were young at the time, looked on these veterans with awe, and wondered if there was any chance of our winning golden spurs such as they had and have worn so long, for happily Dr. Hogg, the Rev. M. J. Berkeley, and Colonel Clarke are still with us. Mr. Barron, then as now, was the respected chief, and his aide-de-camp, Mr. Frederiek Bause, was then busily engaged in raising the new hybrid varieties of Coleus, Caladium, and Dieffenbachia, which at the time were very valuable and much admired. Even the painter (C. Field) and the carpenter (G. Davis) were men above the average. Cheerful and amiable George Gale has but just left us; and the seedsman, dear chatty Benjamin Hide, or old "Ben," as he was familiarly called, was a loveable character—a genial, honest member of the old school of what he called the "Japonicas," which term he used generically as including all gardeners whatever. The word "Japonica"—a very common specific name at Chiswick, when Fortune's collections were arriving from Japan—reminds me that I am pledged to suggest to you something about plants and plant nomenclature, and even if I tell you much that you know already, still I hope there may be a few hints and suggestions in this paper worth your bearing in mind.

The first use of a name is to distinguish different individuals, different places, or different things, and, unless it does this definitely and precisely, it is a bad name. A really good name is that which leaves no doubt of identity or locality, and it should be, if I may use such a homely illustration—"like a donkey's gallop—short and sweet!" The shorter and prettier names are the better as a general rule. Remember always, however, that a good name yields light, and a bad or imperfect name really obscures truth by disguising facts, and I want you to look a little deeper than nomenclature, and to dive down for yourselves into the heart and soul, so to speak, of natural things. I need scarcely remind you that all original workers, all reformers, all earnest men, whatever, gain their reputation by the study of actual things. Darwin's nomenclature is of the simplest, but he not only placed botany on a higher plane by his observations and his records of the life-history of simple things, but he really turned the whole river of modern thought and feeling.

Nomenclature has always been beset with difficulties, and I am sorry we cannot say that it is perfect now. But there is a simple way for you to make it perfect for yourselves, and the condition is this: Always learn the actual meaning of a name you read, be it in Latin or Greek. This you can do to a great extent from Johnson's "Gardener's Dictionary," or any other good work of the same kind.

In olden days in England men of any celebrity were named from the places they inhabited, or after the calling they followed; thus we had William the Conqueror, William of Wykeham, or Geoffrey of Boulogne, the Black Prince, named after the colour of his armour, and the first Earl of Pembroke was named "Strongbow," presumably from his prowess in battle. In Sir Walter Scott's "Fair Maid of Perth" you will remember the brave smith, "Hal o' th' Wynd," he who "fought for his own hand;" and another Scotchman, handsome and young, and famous in song, was simply known as "Joek o' Hazledean." This naming from native or birthplaces would not do in these times of rapid transit and frequent removals, and the old custom of naming a man from his trade results to-day in having Glovers who keep a bakery, Cartwrights and Carpenters who study science or law, Smiths who are artists or in the Church, while Tanners and Bakers, Turners and Goldsmiths, may, and often are, engaged in any profession or calling rather than in those after which their ancestors were originally named. The giving of names also after geographical locations, or in allusion to some peculiarity in leafage or blossoming of the plant itself, has led the botanist into difficulties; thus, amongst many other instances, *Primula longifolia* has really shorter leaves than many other species; *Libonia floribunda* is generally a very shy blooming plant in gardens; *Vallota purpurea* has orange-red blossoms, not purple ones; and *Narcissus montanus* (*N. pucelliformis*) is said by Salisbury to grow in deep valleys of the Pyrenees; while only yesterday I sent to the British Museum and elsewhere a self-fertilising form of a South American Orchid, called *Pilumna fragrans*, having perfectly scentless flowers. All these instances go to prove that descriptive names can never be safely applied until after all the species, and even varieties, of a genus are collected and well known. Clusius, one of the earliest of plant collectors in Europe, got out of difficulties of this kind (v. "Clus. Hist.," 1601) by numbering his species I., II., III., instead of naming them; and seeing that so many mistakes in naming arise from an insufficiency of knowledge, it is a pity some provisional system of numbering is not now resorted to whenever a doubt exists, a name only being given when it is quite certain that a plant is new and hitherto undescribed. If a rule of this kind was generally followed, we should have far fewer additions to that vexatious and confusing synonymy which now exists.

(To be continued.)

#### EXHIBITING AND JUDGING BOUQUETS.

"AN AMATEUR FLORIST" is quite right when he says I am an occasional competitor at shows, but I do not think he competes very often, or he would not recommend me to protest against such a small matter as putting in a few Fern fronds. I did once speak about it, and the answer I received was something like this:—"Do you think we have nothing else to do but trouble ourselves about such a frivolous matter as that? No, Mr. 'Learner,' do not grumble, but take your beating like a

man." One of my objects in writing on this subject is to see if by thoroughly discussing showing and judging we can bring about a better state of things, as if we could it would be advantageous both for judges and exhibitors. I am not sure that I am competent to discuss contrasts or shades of colour, and it is not the object of this paper to do so, as tastes differ so very much in this respect; but I will pass to Mr. J. R. Chard's letter, and will take the dinner table first. I know the exhibit to which he refers, and I will, if you will allow me, give the exact particulars. There were three entries—two were from amateurs who had never before exhibited in competition in such a class, and the other was Mr. Chard. The schedule reads thus:—"For a dinner table 10 feet by 4 feet 6 inches, laid out for ten persons, and arranged so as to show the best means of utilising fruit and flowers in its adornment." Mr. Chard has done his work in his well-known style, but having other exhibits to see to in a stronger competition, and seeing he had nothing very strong against him in this class, he was decidedly careless, hence his inability to protest. One of the others was a very weak copy of Mr. Chard's table; but the one that had the first prize had three very heavy stands, chiefly of Marguerites and Grasses, with four dishes of fruit, two of each kind, a Pine, and a Melon. I pointed out to the referee Judge (the two Judges could not decide) that the table was not according to the schedule. He said he did not care, it was first. If I had been the Judge I should certainly have withheld the first prize, as they were all so bad. Now in this and Mr. Chard's case of the competition, where the large bouquets took the first prize in a 10-inch bouquet competition, I am quite certain the judging was wrong, and could have been upset. I once exhibited at the Crystal Palace when the limit was 9 inches, which is too small. A very large beautiful bouquet was shown by a London firm, but was marked "disqualified, too large." If all the judges would do the same without fear or favour I am certain it would soon be the means of making the exhibitors more particular.

A word as to the value of the bouquets exhibited. Mr. Chard, I think, has only himself to blame for the present state of things. I could name one very good exhibitor of bouquets, whose method in making a bouquet for shows was always to take into consideration the value of the first prize, and to exhibit a bouquet about that value, but Mr. J. R. Chard in his endeavours to beat that exhibitor began to show costly bouquets. After a time someone else came on the scene with more costly ones still. I do not see how that state of things is to be altered except by having judges who would altogether ignore the value of the bouquet and give the prizes to the best made ones.

As to the size of a bouquet, I have seen a few, and it should be the practice for all shows to have one uniform size; and the most fashionable and handiest size is a bouquet with flowers and Fern 15 inches in diameter, or including paper not to exceed 18 inches. That would meet all requirements, as if no exhibitor showed a bouquet more than 10 or 12 inches across, the difference between that and the largest would not be much, and they would altogether have a more uniform appearance. Have "not to exceed 18 inches" inserted in the schedule, and give the judges instructions to rigidly carry out the wording of the schedule, also Mr. Robson's rule 1. I think I have said all I can on the subject, and if some other of your readers can assist with any suggestions in carrying out the above what a happy future there is in store for judges and exhibitors (the winners of prizes especially); and I will conclude by wishing them, judges, exhibitors, readers, and yourselves a Merry Christmas and a Happy New Year.—A LEARNER.

#### UNDER GARDENERS AND EXHIBITORS.

"A LOVER OF JUSTICE" has opened a large subject on page 495, and despite his signature, I think he is scarcely just to all. But to start fairly, let us look at some of the side issues. First, he says, "in many cases the under gardeners have all or the bulk of the work to do." Perhaps so. I have found that is the case in all places of any size, whether exhibiting is done or not. The head gardener has enough to do the brain work properly, without attempting anything else, and if he leaves some of the latter to the foremen, it is to their advantage to exercise their heads a little as well as their hands. If ever our friend gets into a good head place he will probably find there is more to do in that way than he expected. As the pressure of the times increase this increases also, and if exhibiting is done it adds to this enormously.

If the men work overtime, whether for exhibiting or anything else, they ought certainly in all cases to be paid a fair wage for it. I never would ask a man to work overtime if it were possible to avoid it, as it is wrong in principle. Twelve hours is long enough for anyone to be at their work and meals. They ought to have some relief to the mind; and besides, if overtime is made one day, the next day's work has to suffer for it, whether such overtime is paid for or not. I must say I like to see any of my men come in the garden occasionally for an hour after tea if any little thing wants attention. This tells me they take an interest in their work, and are studying my interest too, and therefore most certainly their own also. I wish all young men put as much value on their spare time as your correspondent does. But is it not possible for a young man to get anything besides money from exhibiting? Most certainly they can; that is if they like to profit by experience, for if anything is to look well on the exhibition table it must be grown to the greatest possible perfection.

Again, he says, "the gardener gets all the credit." This is not true in many cases, and as an instance, I owe my situation, which is one of the best in the kingdom, to the fact that when my present employers came to look round the gardens where I was then foreman, they saw, to put it

in their own words, "there was a good foreman." Depend upon it no extra exertion on the part of a subordinate is lost to himself. It makes a better man of him, and spurs him on to greater exertions, which are sure to tell in his favour eventually. I have served under some of the worst masters in this country, but always found that they appreciated a man who took a decided interest in his work; and besides, if a man gets the terms he agrees for it is his duty to do all he can. How many do we find do that? I know some do, but often have reason to wish more did, both for my sake and theirs. As to the cases mentioned where the young men had their own expenses to pay, surely the best way would have been to explain the case to the master. Probably it was an oversight, or if not, I can safely say such instances are very rare. If a young man keeps his eyes open at a show he will gain knowledge that will eventually be of more use to him than the cost of his train fare, or the show will be a very poor one; and as to the gardener "being allowed to show and have what he makes," possibly your correspondent did not know all the facts of the case. It is not well to put everything in print that we know, or much more might be said on this point. And now as to sharing in the prizewinnings. Taking exhibitors as a whole class, there are, of course, some who do better than others, but I find when all expenses are paid, taking one year with another, there is not a great deal of money left from exhibiting. I am quite ready to admit the young men deserve some encouragement, according to the interest they have taken in the matter; but how about sharing in the expenses in cases of failure, which happen to the best of exhibitors? Perhaps that did not occur to your correspondent.—A HEAD GARDENER.

#### CHRYSANTHEMUM NOTES.

##### AMY FURZE.

YOUR correspondent "T. W.," page 532, considers that this variety should (1) either be confirmed as a reflexed kind, each flower to be judged on its merits and not subjected to be either passed or lose points; or (2) it should be relegated to the Japanese class; then (3) he suggests a reclassification in which such varieties as Elaine and Dr. Macary may be transferred to the reflexed class. Let me briefly reply to these propositions.

1. The flowers are now judged on their merits as reflexed in reflexed stands, and if they are faulty why should they be treated differently from all other varieties, which are "either passed or lose points," according to the degree they fall from the standard of excellence? 2. The suggestion that Amy Furze should be placed in the Japanese class is confirmatory of my views, that it is not a reflexed variety, therefore the more it displays its Japanese origin the more it must weaken a reflexed stand. 3. The proposition, if carried out, would make confusion worse confounded, and it is earnestly hoped the National Chrysanthemum Society will resolutely refuse to move on the lines suggested. The Committee, I should think, would be much more likely to provide a class for reflexed or hybrid Japanese, as in the case of Japanese Anemones.

Speaking to an experienced Judge the other day he put the matter in this form—"True reflexed Chrysanthemums are of Chinese origin, and have flat florets lying flat on each other; and when large blooms of Amy Furze develop, as they admittedly do, the Japanese character, and proclaim their Japanese origin, they are out of place in stands of reflexed blooms of the true Chinese type." But though out of place in such stands they are judged on their merits when in them, as reflexed blooms with flat imbricated florets, and just in proportion as they "grow out" of this character and become spreading Japanese, in the same proportion they lose points as reflexed flowers. Judges will not disqualify varieties of indefinite character unless specially authorised to do so by the schedule; but they estimate them in accordance with the standard of excellence of the class they are intended to represent, and in doing this wherein do they err?—A JUDGE.

##### CHALLENGE VASES.

THE question raised by your correspondent Mr. Wm. Bardney, is opportune at this season when societies are about to arrange their schedules for next year. A challenge vase under the usual conditions cannot be as attractive to the majority of exhibitors as a prize of the same value to be won once and for all. No one will dispute this point with your correspondent. Exhibitors will, as he says, "be attracted to those shows that offer the greatest advantages;" but societies are limited by their income when arranging their schedules. One that would be able to offer say a prize of £15 in each with a challenge vase value £15, might not be in a position to offer the vase as well as the money prize to be won in one year.

If challenge vases are to give place to prize cards to be won in one year, then I apprehend the value of the latter must be reduced in comparison with the former, and the question arises, Would exhibitors prefer this? But taking higher ground, the competitor who estimates the value of a prize in proportion to the difficulty of winning it is possessed of those qualities which will make him successful in whatever direction he may compete. To be the holder of a prize won against all comers for two years in succession is an honourable distinction which cannot be claimed by the winner of a prize in one year. The winners of trophies under such conditions as those in force at Kingston, Hull, and Liverpool should not be placed on the same level as those competing under less difficult conditions.

Chrysanthemum societies are formed to encourage and promote the cultivation of our favourite autumn flower in the neighbourhood where



they are instituted; and whilst money prizes should be sufficient to repay the successful exhibitor for his early and late toil, and sufficiently valuable to attract exhibitors from a distance, challenge vases are given as an additional reward to pre-eminent and deserving skill, the ambition to possess them being a great stimulus to superior culture and determination to succeed wherever they are offered. Let it be clearly understood that the challenge vase is "an addition" to the money prize. The amount of the money prize must not be reduced to make way for the challenge trophy. I would then ask, Who would not rather compete for the coveted prize with the trophy added than without it? Societies should make their money prizes as large as possible, leaving it for gentlemen of wealth and position to add the challenge trophy. Gentlemen are more willing to give a piece of plate to be won under the usual challenge conditions than they would be to give it to be won in one year. No sooner had the challenge vase been handed to Mr. Mease at the Hull Show this year than Lieut.-Col. Gleadow generously offered to replace it.

Mr. Bardney refers to instances where ill feeling has been created in consequence of challenge vases being given to be the property of the employer. This condition is specially laid down to prevent misunderstanding, and I fail to see the application of his reference. Employers do not value these cups for their intrinsic worth, and it is the custom to make over their value to the gardeners. It is to be hoped for the credit of employers that the instances to the contrary known to Mr. Bardney are rare exceptions. Your correspondent refers to the poor competition for the challenge vase at the Hull Show in comparison with the value of the prize. This was no doubt owing partly to the lateness of the season, and also to the reluctance to compete with Mr. Mease, who was placed under a disadvantage by the lamented death of his late employer. May I add that a prize was never handed by a Committee to a successful exhibitor with greater pleasure than this one was?

It would be useful to know if exhibitors would prefer cups of reduced value to be won in one year in place of more valuable challenge trophies to be won under the usual conditions.—EDW. HARLAND, *Joint Hon. S. C. Hull and East Riding Chrysanthemum Society.*

#### A REPRESENTATIVE CHRYSANTHEMUM CLASS.

THE excellent suggestion of 'M. N. C. S.' for increasing the number of blooms shown and the manner of displaying them requires some consideration, especially from those who, like myself, are growers and exhibitors. I think with 'M. N. C. S.' that it would be advisable for exhibitors having large collections to choose from to stage seventy-two blooms, but I do not think it would add to the uniform and effective appearance of the stages to mix the Pompons and singles with the large varieties, for if these latter were shown as suggested, with stem and foliage not less than 4 inches above the board, it would make the benches present a somewhat uneven appearance. As to what varieties should be included in the seventy-two, might I suggest the following, which I think would be an improvement, and would bring more competitors? My selection would be: Twelve Japanese distinct, twelve incurved distinct, twelve reflexed, not less than eight varieties; twelve large Anemones, six varieties; twelve Japanese Anemones, four varieties; and four Mrs. G. Rundle, four Mrs. Dixon, and four Mrs. G. Glenn. I think the value of the prizes should be revised also; say: First, £12; second, £7; third, £4; fourth, £2. And perhaps it would increase the popularity of our shows if competitors were allowed the option of taking their prizes in hard cash.—W. DROVER.

#### RIVAL CHRYSANTHEMUM SHOWS.

MR. UDALÉ in his admirable letter published in last week's Journal with the above heading has, I believe (though I am sure quite unintentionally), somewhat misrepresented our position as members of the Sheffield and West Riding Chrysanthemum Society. He says, "There ought only to be one representative exhibition," and as an abstract proposition I cannot but agree with him in this, but as a matter of fact I contend there is not and never has been more than one "representative exhibition" held in Sheffield. "The Sheffield and Hallamshire Gardeners' Mutual Improvement Society" is not a Chrysanthemum Society, nor can its exhibition in any way be looked upon as representing Chrysanthemum culture in this district. The Society was formed about twelve years since for the purpose of promoting the mutual improvement of its members, firstly by monthly meetings at which lectures are given, or essays read, and discussions promoted upon horticultural topics; and secondly by making small grants of money from the funds of the Society in cases of need through sickness or death in a member's family. The Society has from its commencement been strictly limited in its membership to men employed as gentlemen's gardeners either head or under men. Any person not so employed can only enter the Society as an honorary member, and as such cannot participate in any of the privileges or have any vote in the management of the Society's affairs. The Society thus formed progressed very satisfactorily during the first years of its existence, and received a fair amount of support and patronage from the employers of its members, and especially from its President, Ven. Archdeacon Blakeney, D.D., Vicar of Sheffield, who has from the first been its staunch and consistent friend and supporter.

Very early in the Society's history it was decided to inaugurate an annual exhibition, limited to members of the Society, to be held in the Cutlers' Hall, and as there was then no Chrysanthemum Society in Sheffield, or any public exhibition in November, that month was fixed upon in which to hold it. Chrysanthemums were, however, at that time in Sheffield, as in many other towns, very indifferently grown and

shown, so that it was from the first really more of a Primula show than a show of Chrysanthemums. The Society has thus continued to hold this its annual show in the Cutlers' Hall from nearly its commencement to the present year; but with the exception of one season only, I believe in 1879, until the present one, each of its exhibitions have been strictly limited to its own members, and each year until the present, viewed alone as a Chrysanthemum show, the exhibits have not equalled in the quality of flowers those to be found at the numerous cottagers' and amateurs' shows, held at various hotels in Sheffield. At the commencement of the present season, recognising the success which had attended the two previous exhibitions of our more recently formed Sheffield and West Riding Chrysanthemum Society with its open and unrestricted schedule, the Committee were stimulated to make one single open class for forty-eight blooms, or, to be strictly accurate, two classes, one for twenty-four incurved and one for twenty-four Japanese blooms, but with the sole exception of these two classes the exhibition was, as in previous years, strictly limited to members of the Society. As Mr. Udalé truly remarks, the addition of these two open classes greatly improved the whole character of their show, but with such addition the exhibition could not, scarcely more than formerly, be considered a representative one. Mr. Udalé also claims for this Society the right of priority. Certainly as a representative Chrysanthemum show we dispute this claim on the grounds as above given.

As has been frequently stated in this Journal there are in and around Sheffield great and annually increasing numbers of enthusiastic amateur and cottage growers of the flower, many of whom are successful in producing really fine flowers, but none of whom until the formation of our Society could exhibit them in Sheffield otherwise than at the shows held, as before stated, at public houses, from the fact that they were not, nor could they be admitted, as members of the Gardeners' Society. Even Mr. Udalé himself, at that time gardener at Shirecliffe Hall, Sheffield, and for four or five consecutive years annually producing some of the first examples in the kingdom, both of trained specimen plants and of exhibition blooms, was debarred from exhibiting in Sheffield from the fact of a technical objection being raised by the Committee as to his membership of the Gardeners' Society. What, however, Sheffield Chrysanthemum growers most strongly objected to was the fact that this Society, spite of its very limited character, chose to give to their Show the title of "The Sheffield Chrysanthemum Show," thus giving a very false impression to patrons as to what was really being done in Chrysanthemum culture in this district. Under these circumstances the Walkley Amateur Floral Society took the initiative by calling together a meeting of all the best known growers to discuss the matter, which was largely attended, and at which a resolution was adopted that the Gardeners' Society be appealed to "that they form open classes at their show so as to allow of anyone, gardeners, amateurs, or cottagers, competing by paying an entrance fee," and a promise was made to assist such Gardeners' Society to the utmost extent in promoting and maintaining such open classes. This appeal was duly made and sustained for a considerable time by repeated letters to the Secretary of the Gardeners' Society, but which met with a most peremptory refusal on the part of the Committee to entertain the proposition, and the idea had finally to be abandoned, in consequence of which a second gathering of growers interested took place, and the decision was unanimously come to, to establish the present Sheffield and West Riding Society.

No reason has ever yet been found for regretting such decision, as our Society has been a success from its commencement and has met with most hearty support as well from the Sheffield wealthy classes as from the very numerous amateur gardeners who now rank as ordinary members of the Society to the number of about 150. From the success our Society has just achieved, financially and otherwise, at our recent Show, we are fully assured of our ability to stand alone, as at present, and to continue our work with increasing success; but Mr. Udalé is correct in asserting that nine-tenths of our members would welcome the opportunity of blending the two Exhibitions so as to make one equal to any held in the country, and which we think to be quite possible of realisation.

What we would suggest in the matter is that the Gardeners' Society continue to carry on the work of mutual improvement and pecuniary benefit of its members for which it was originally formed; that they cease to hold their annual Show, which has for years past proved to be a financial failure, and that such of their members who are most interested in Chrysanthemum culture take office upon the Committee of our Society, so as to have a part in the formation of our schedule and in the management of our Society. This, I believe, would have an effect in strengthening both Societies, as numerous gardeners who now hold aloof from the Mutual Improvement Society would thus be induced to become members, and the Show of the Chrysanthemum Society would be greatly improved by the introduction of more exhibitors in the classes for groups and specimen plants. That such a dream may be very near its fulfilment is my earnest wish.—W. K. WOODCOCK, *Hon. Sec. Sheffield and West Riding Chrysanthemum Society.*

#### A CHRYSANTHEMUM CATALOGUE.

MANY growers like myself hope that when the National Society issues the next edition of the Catalogue it will be thoroughly revised and brought up to date. It is defective in several respects, and does not contain all the varieties now in cultivation. A large committee should be appointed, and ample time allowed for the compilation of the work.—H.





### KITCHEN GARDEN.

**ASPARAGUS.**—Our second plants of this which were placed in to force are now ready for cutting, and we shall have abundance at Christmas. Just now it is the most acceptable of all vegetables, and a few dishes give much satisfaction. Where the kitchen garden is of good size it pays well to raise a quantity of roots from seed annually and force a like number of matured crowns. They are not ready for forcing until four years old at least, and when beds or plantations become old the roots may be all taken up and forced. Our November-forced produce is sometimes not quite so strong as that grown in the spring months, but it will grow as freely and strongly in January as in February and March, and those with roots to force may begin at once, as the produce now will be double the value of the later crops. The best mode of forcing has been detailed in a recent number. Asparagus plantations in the open are apt to be neglected in winter. We have often seen them with the old stems adhering to the roots in March. This is a bad practice, and must never be tolerated by those who wish to have good Asparagus. Clean all such beds at once, and if there is not enough manure to spread over the surface place a forkful over each root.

**BRUSSELS SPROUTS.**—These are now doing good service in the kitchen. They are turning out well, and we consider them one of the best of all open air winter vegetables. The side leaves are now becoming yellow up to near the top, and these are more injurious than beneficial to the plants. They should all be removed, but do not disturb the green top, which acts as a protector to the sprouts below, and when all have been used the tops may be cut off and used as well.

**SEAKALE AND RHUBARB.**—Both of these are being forced freely, and produce will be plentiful at Christmas, but the first supplies will soon be over, and if there is plenty of roots do not fail to start some more to succeed the last that were put in. Both kinds of roots should still be lifted and forced in a dark warm place. As soon as the Rhubarb has all been gathered the roots are of no further use, but it is different with the Seakale, and if these are taken care of they will again make good plants.

**CELERY.**—Much Celery is grown for use in the autumn months, but it is at this time of the year and on throughout the winter that it becomes most useful in the pantry as salad, and in the kitchen stewed. In the latter way it is a delicious vegetable, and it is altogether so valuable, that all who possess a few trenches of it should do their utmost to preserve it as long as possible. Hitherto we have not had sufficient frost to injure the foliage, and it is still fresh and green, but severe frost is apt to make the growth pulpy, and after that it is only the part that is well buried by earthing that is sound. It is better to prevent the foliage being too much injured, and on the first indication of severe frost a good quantity of straw or bracken should be spread over the whole of the plants. When it thaws and the weather is fine, this covering may be removed and placed between the trenches ready to be applied again when necessary.

**BROCCOLI.**—We do not remember a more favourable autumn for Broccoli than this has been. We are cutting several dozens of heads weekly. Veitch's Self-protecting Autumn variety was the first to afford heads early in November, and although this is not yet over, there are others ready, and amongst these Osborn's is fine, and Sutton's Winter Mammoth excellent. Should frost, however, become general, they will cease to do so well, and all that are ready should be used with care. Do not send any more to the kitchen than are actually wanted, and store all the surplus heads that are ready for cutting. Cut them with 6 or 8 inches of stem attached, trim some of the leaves off this, and insert the stem in damp sand in a cool rather dark place. We fill several of our cutting boxes with sand, place a dozen or more Broccoli in each, and then move them into a suitable place. We have pulled up the plants altogether, tied a piece of twine round the stem, and hung it head downwards in a cool shed, but they do not keep so well in this way as with the stem in damp sand or leaf soil. If stored before becoming too large, or before frost injures them, they will remain good for a month or five weeks.

**ROOT STORES.**—When roots are stored that are slightly damaged they may not begin to decay at once, but they are sure to do so before the winter is far advanced, and the present is a good time to examine all roots. The best way is to turn them quite over and re-store, and as they are moved throw all bad ones to one side. Onions are not keeping so well as we have seen them do after a far less maturing season. The earlier varieties are showing a disposition to grow, and when this happens they become useless. Any in this condition should be removed, and those which are still sound should be placed in a very cool situation. A high temperature is ruinous to them. White Turnips of large size should be drawn and placed in a cool shed under a covering of straw. Swedish Turnips are best left in the ground until far into spring.

**SPRING CABBAGES.**—These are very promising, and as all the blanks were filled some time ago our plantations are quite full, but where there are still vacancies in the rows they may be filled at once, and a small

handful of soot should be sprinkled round the stem of each plant. If the soil is dry and a little earth can be drawn to the stems all along the rows it will assist them greatly when frost comes.

**SALADS.**—A great deal of these will now be wanted. Lettuce and Endive in frames remain fresh and sound. It is important that they be kept from damp. Sow Mustard and Cress, as they may always be had quickly in a little heat when other salads are scarce. Radishes in the open air ought to be plentiful and good in all gardens. Our China Rose variety, sown in September in long rows between Strawberries, is now as fresh, crisp, and good as any Radish could be in the most favourable month in the year.

**WINTER-SOWN PEAS.**—Last winter we made one sowing of Peas in November, one in December, and one in January, and those sown during the second week in December did best, as they were the most robust in growth and the first to pod in the spring. We, therefore, did not sow any Peas in November this year, but a good sowing will be made during the second week of December, and we would advise all to try a few rows at this time. Only the very earliest varieties, such as Ringleader, William I., Sutton's Earliest Blue, or Carter's Lightning should be sown. Manure the ground well, do not crowd the rows on each other, as they require all the light and sun available, and sow in drills 4 inches deep. After opening the drills tread the part where the seed will rest firmly, as they make the best growth in firm soil, and after putting the soil back over the seed surface it with a sprinkling of finely sifted ashes. The young plants will push up through these, and slugs and other depredators will not trouble them.

**GRUB ANTIDOTES.**—Everyone who has owned a kitchen garden for any length of time soon finds that grubs prove troublesome and destructive to some crops. This applies particularly to Carrots, Onions, Parsley and some others, and wherever their presence is suspected in the ground intended for these crops in the coming year an antidote should be applied. Gas lime, soot, and salt are three of the materials we use, but the first and the last do not suit the crops if applied immediately before sowing, and the best way of using them is to dig them into the soil at this season, and then the ground will be in splendid order for the crops by March or April. As in the case of the other lime we never weigh our gas lime as to the rate per acre, but put it on to suit the case, and a light sprinkling is sufficient to destroy almost all grubs. The same remarks apply to salt, but soot may be used more liberally.

### FRUIT FORCING.

**PEACHES AND NECTARINES.**—*Earliest House.*—Cease syringing the trees when the flowers show colour, maintaining, however, a moderate moisture in the house by damping the floor on bright mornings and in the early part of bright afternoons. The temperature may be maintained at 55° by day, 50° being sufficiently high for the night, and if the temperature falls to 50°, and in very sharp weather to 40°, it will be more an advantage than otherwise. Examine the inside borders, and give, if necessary, a thorough supply of water at a temperature slightly in advance of that of the house.

*Second Early House.*—The trees for affording fruit at the close of May or early in June must have their final dressing if one be necessary, be tied to the trellis if not already done, and the border inside well watered. The house should then be closed, employing no fire heat except to exclude frost, damping the trees and house in the morning and early afternoon of bright days. Fire heat must not be applied by day to raise the temperature above 50°. Protect the outside border with dry fern or litter, and if means are at command for throwing off heavy rains or snow it will be desirable to employ them.

*Succession Houses.*—Push forward pruning and dressing trees after loosening them from the trellis, cutting out any weak attenuated wood, and where crowded thin well, leaving space between the current bearing wood for training in that intended to displace it. Secure the branches at once to the trellis, leaving space in the tree for the swelling of the shoots—*i.e.*, secur. loosely. The surface soil should be removed down to the roots without disturbing them, and give fresh material—good turfy loam with an admixture of well-decayed manure, about a fourth, and a twentieth of bonemeal, not covering the roots more than 2 or 3 inches deep. Carefully examine the inside borders, as dryness at the roots will cause the buds to fall later on.

Houses which are to be started early next year should have the frost merely excluded now, completing the needful operations in cleaning, pruning, dressing, and tying the trees in later houses. Although the trees when at rest should be kept cool and dry it is not desirable to expose them to many degrees of frost, indeed frost should for the most be excluded.

**FIGS.**—Trees in unheated houses should be unloosened from the trellis or wall, have the branches tied together in convenient bundles, and be covered with a single thickness of mat and then some dry straw or Fern a few inches thick, securing with tarred string, mulching over the roots with some short rather littery material to a depth of not less than 6 inches, which insure safety to the roots, whilst the covering with straw or other material will not only insure the branches against frost, but tend to a more complete state of rest.

*Unsatisfactory Trees.*—This may arise from various causes. It is usually on account of the soil. It may be too rich and loose. A dressing of lime an inch thick may be pointed in as deeply as the roots will permit without disturbing them much, and after resting a time and when in good order tread it firmly. If the trees make long-jointed wood the better plan is to lift them carefully and replant, making the soil more

firm, using the lime all the same. If the soil be of a light nature an admixture of clay marl will improve the staple, tend to encourage shorter-jointed wood, and increase the size and quality of the fruit.

**PINES.**—Preparations must be made for producing ripe fruit during the months of May and June. Smooth-leaved Cayenne, Black Jamaica, and Charlotte Rothschild, which failed to show fruit during October and November, will not now throw up in time to ripen at the period in question; and attention must be directed to such as attain perfection in less time, such as the Queen, Enville, Providence, &c. Choose at once those plants which have an enlarged base, with a tendency to open at the centre, signs of the fruit being shortly visible, placing them in a light house or pit, affording brisk bottom heat of 85° to 90°, a top heat of 60° to 70° at night, 70° to 75° by day, and 10° more when the external conditions are favourable. A genial atmosphere should be maintained, but not to produce it from steam resulting of syringing the hot-water pipes, as syringing the plants overhead once or twice a week is ample, and then very lightly, on fine afternoons damping the house. See that the soil is in a proper condition as to moisture, using tepid water, with a dash of guano or some fertiliser in it, applying it copiously when required, which will be about every ten days.

**CUCUMBERS.**—The weather may not have necessitated sharp firing, but there has been an absence of sun, which is generally resultant of a weak, attenuated growth. Light is very important in the cultivation of the cucumber in winter, and now the days are so short keep the glass as clean as possible both inside and out. Do not apply strong liquid manure too freely, as it is the reverse of good treatment to stimulate them unduly at any time. The soil, however, applied to the roots should be rich and sweet. Be careful not to overcrop the plants, and do not allow the fruits to hang too long. They keep fresh several days after being cut if the heels are inserted in saucers of water in moderate heat. Remove superfluous fruits as they appear, and tie the growths as necessary. Red spider should be subdued by syringing the infested leaves with a weak solution of softsoap (2ozs. to the gallon)—a safe remedy, but care must be taken not to damage the leaves. If mildew appear, dust the affected parts with flowers of sulphur, and reduce the atmospheric moisture. Green or black aphides may be destroyed by dusting them with tobacco powder, or fumigation on two or three consecutive evenings moderately. An overdose may do irreparable injury.

Where early Cucumbers and Melons are obtained from frames, or pits heated by fermenting materials, some fresh Oak or Beech leaves should be thrown together, with one-third of stable litter, and, if necessary, be moistened so as to induce fermentation. It should be turned when warmed through, alike to sweeten, to bring all into a genial state of warmth by turning the outside to the inside, and to induce thorough incorporation of the materials.

#### PLANT HOUSES.

**Allamandas.**—Where these are required in bloom as early as possible in the season plants that have enjoyed a good rest in a temperature of 55° may be started. These plants may either be repotted before they are introduced into a warmer house or after they have broken into growth. We have potted them at both periods, and have found no appreciable difference in the results, and therefore prefer doing it before they are started. The plants should be turned out of their pots and the roots reduced, being careful to preserve as many fibry roots as possible. The soil should afterwards be soaked in tepid water and allowed to drain before potting. If the plants have been in large enough pots the same size may be used. If necessary to increase the size of the plants do not reduce the old ball so liberally, and transfer them into pots one or two sizes larger than they were resting in. They should be clean and liberally drained. The soil may be pressed as firmly as possible, and the plants then placed into a house with a night temperature of 65°. If they can be plunged in leaves or other fermenting material so much the better. The plants should be syringed twice daily, but no water will be needed at the roots before they start into growth. Use for a compost rich fibry loam and one-seventh of decayed manure. Plants that are growing in borders should have the surface soil removed and top-dressed with equal parts of loam and manure.

**Bougainvillea glabra.**—If the earliest plants have not been pruned this should be done at once by the removal of unripe and all puny shoots. Nothing is gained by crowding the plants with weak wood that will not produce shoots strong enough to flower. When pruned the plants should be moderately thin, and a number of shoots of equal strength encouraged sufficient to furnish the plants with flowers after they are tied down. Plants that are not pruned should not be started for at least a fortnight afterwards. Those already pruned may be started in the same temperature as advised for Allamandas. They can either be repotted or top-dressed with rich material. If the former do not reduce them more than one-third, use the same soil as recommended for Allamandas, whether for potting or top-dressing, and press it firmly into the pots. This plant will do in the same size for years if the drainage is good and they are liberally treated.

**Clerodendron Balfourianum.**—This plant will not bear disturbing at its roots so much as either of the preceding. When once they have been given their largest size they will do in the same pot for years, provided they are top-dressed with decayed manure and fed freely during the growing season. When confined at their roots they are induced to make firm short growths all over the plant, which flower with greater freedom than long shoots that are freely made by young plants or those with ample root room. Soak the soil with tepid water before introducing them into brisk heat. Plants that are declining in health may

be recruited by turning them out of their pots and carefully reducing the old roots one-third, and then repotting them into the same sized pot in a compost of fibry loam two parts, one part of peat and one of leaves or old Mushroom bed refuse. To this may be added charcoal and coarse sand. In the case of old plants this should not be done before they break into growth. Much the better plan is to throw them away and bring on young healthy plants to replace them, which in three years from the cutting will cover very large trellises. When giving young plants their final shift into 14-inch pots add one 6-inch potful of half-inch bones with the fine amongst them to every bushel of the compost that may be needed. Plants still at rest must not be kept in a lower temperature than 55°, for if starved they are very liable to die.

**Stephanotis floribunda.**—Plants that were well ripened, pruned, and kept for the last month in a temperature of 50° may now be started with the plants enumerated above. Soak the plants thoroughly with tepid water, and after they have drained place a good layer of manure on the surface and arrange them where they can remain until they come into flower. They should be moderately close to the glass, so that directly growth commences strings can be secured to the trellis and under the roof, upon which to train the young growths. Considerably more flowers are produced by this method than if the shoots were tied to the trellis as they extend.

**Gloxinias.**—These may be started by laying the tubers amongst leaf mould, in pans or boxes, until they commence growth, when they can be carefully lifted and placed into pots according to the size of the tubers. They may be stood on the surface in the forcing house amongst large stove plants that are being started.

**Achimenes.**—Place these thickly together in pans of light sandy soil and arrange in the forcing house. If the soil is moderately moist, the pans plunged, and their surface covered with cocoa-nut fibre refuse, they will need no water until growth is visible. A few Caladiums should also be started by placing them in small pots amongst light sandy soil.

#### THE FLOWER GARDEN AND PLEASURE GROUND.

**Selection of Roses.**—Roses may be planted whenever the weather is mild and the ground in a good working condition. Let the weather be what it may, however, no time should be lost in ordering any that have to be bought in, or the chances are a difficulty will be experienced in procuring strong plants of the varieties needed. If received when the ground is in an unfavourable state for their reception, lay them in carefully by the heels till they can be planted, taking care to protect them with strawy litter in the event of severe frosts being threatened.

**Hybrid Perpetuals.**—As we have previously remarked, standards or those with an exposed stem of any length are the most unreliable, being the first to suffer from frosts, and at their best are not often very ornamental. If the Briar stems or stocks are protected with hay bands, Fern fronds, or straw, it must be a very severe frost that will cripple or destroy the Rose, but such protections are unsightly and very few care to adopt the plan. It is the dwarfs that live the longest, and these also usually thrive the best. They may be bought either worked on the seedling Briar or Manetti stocks, and in either case if the point of union is buried slightly below the surface the Rose also emits roots freely, becoming in time equal in every respect to own root Roses. It is either the neglect of this precaution or ignorance of the value of the practice that leads to so many dwarf-worked Roses being planted too high, these in time becoming miserably stunted and seldom last long. It is not advisable to plant deeply where the soil is of a heavy or clayey nature, moulding up the stems heavily being a preferable proceeding. We shall give a list of thirty-six varieties that can be depended upon, and if less in number are required the first twelve or more may be taken as well-varied selections. These are Alfred Colomb, A. K. Williams, Baroness Rothschild, Captain Christy, Charles Lefebvre, Comtesse de Chabrilant, Comtesse d'Oxford, Duke of Connaught, Etienne Levet, General Jacqueminot, La France, Mons. E. Y. Teas, Countess of Rosebery, Duchess of Bedford, Duke of Wellington, Ulrich Brunner, Dupuy Jamain, François Michelin, Her Majesty, John Stuart Mill, Jules Margottin, Merveille de Lyon or White Baroness, Madame Eugénie Verdier, Marie Baumann, Abel Grand, Beauty of Waltham, Boule de Neige, Charles Darwin, Duchess of Connaught, Edward Morren, Harrison Weir, Mdle. Annie Wood, Sénateur Vaisse, Camille Bernardin, and Annie Laxton.

**Teas and Noisettes.**—Sunny walls are the best positions for these, where, if treated as liberally as they deserve to be, they grow vigorously and flower abundantly early and late. The Teas also thrive admirably in the open, more especially in the more southern districts; but even in favoured localities they ought to be grown as dwarfs, and be roughly protected during the winter with a good depth of strawy litter or dried bracken. Frequently these and other dwarf Roses are killed down to the snow line, or to where protected with litter; but supposing a few of the lower buds are well covered, they recover, and are all the better for this severe shortening back. The following are all worthy of a place in any collection:—

**Teas.**—Catherine Mermet, The Bride, Maréchal Niel, Etoile de Lyon, Gloire de Dijon, Comtesse de Nadaillac, Alba rosea, Madame Lambard, Marie Van Houtte, Souvenir d'un Ami, Madame Hippolyte Jamain, Adam, Isabella Sprunt, Homcre, Niphetos, Perle de Lyon, Rubens, Souvenir de Paul Neyron, Madame Falcot, Devonensis, Anna Olivier, Sunset, Grace Darling, and Belle Lyonnaise.

**Noisettes.**—Celine Forestier, Cloth of Gold, Lamarque, Jaune Desprez, Madame Caroline Kuster, Rêve d'Or, William Allen Richardson, and Triomphe de Rennes.



*Hybrid Teas.*—As these partake largely of the habit and vigour of the Hybrid Perpetuals, they may be grown and treated much the same as advised for them. The best are—W. F. Bennett, Lady Mary Fitzwilliam, Countess of Pembroke, Cheshunt Hybrid, one of the most useful Roses in cultivation, and good for all positions; Viscountess Falmouth, Distinction, and Duchess of Connaught.

*Bourbons.*—Although a small section, it yet includes several desirable and serviceable varieties—notably, Souvenir de Malmaison, very free either as a dwarf in the open or against a wall; Queen of Bedders, showy, and suitable for massing; Baron Gonella, late, and forming a good succession to the majority of Hybrid Perpetuals; Aedalic, fine for walls, white, and very free; Sir J. Paxton, an old favourite, and very floriferous; and Rev. H. D'Ombraïn, the richest coloured of all.

*Hybrid China.*—These are excellent for pillars and the fronts of buildings, and also for the front rows in shrubberies. If only lightly pruned they flower early and late, and are very showy. Brennus, Madame Plantier, Chénédolé, Blairi No. 2, Fulgens, and Juno, are all good.

*Hybrid Bourbon* are also suitable for similar positions as the preceding. Charles Lawson, Coupe d'Hébé, and Paul Ricaut are tried favourites.

*Austrian Briars.*—These are very beautiful either as dwarfs or standards, the blooms being produced throughout the well ripened growths formed during the previous summer. Harrisoni is the earliest, and Austrian Copper, Austrian Yellow, and Persian Yellow complete the best. Rosa rugosa variety are beautiful when in flower, and are very ornamental when well fruited. They can be raised from seed or bought. Those kept with a short clear stem are most attractive and quite hardy. Rugosa and rugosa alba, both single flowering, the former rose crimson in colour, and the latter white, are the greatest favourites.

*Moss Roses.*—There are both summer and perpetual flowering varieties of these, the latter being naturally preferable, but there are several that are beautiful and worth growing among the former, including Gracilis, Captain Ingram, Princess Alice, Crested, Henry Martin, Reine Blanche, Lanci, and White Bath. Good perpetual flowering are Perpetual White Moss, Souper et Notting, Blanche Moreau, Mousseline, and Eugène Verdier. The common pink and old crimson China or Monthly Roses are not so much planted as of old, but they are yet among the best for planted against cottages, sheds, and bare walls generally, and also in the shrubberies.

*Miniature Japanese*, or many-flowered Roses, are suitable for edging beds of Roses, but cannot be termed quite hardy in all districts, and we prefer to keep them in pots. The best are Parquette, The Pet, Anna Marie de Montravel, Lucida, Mignonette, and Perle d'Or.

*Banksians* are suitable for the sunny fronts of houses. They are evergreen and flower freely and early. Fortunei is the best white, and Jaune Serin the largest yellow. The old white is very sweetly scented.

*Evergreen Roses* (*R. sempervirens*) grow rapidly either over rockeries, old walls, or the fronts of houses. Adelaide d'Orleans produces in the summer a quantity of beautiful but scentless pale rose coloured blooms, and Princess Louise and Félicité are also worth growing.

## THE BEE-KEEPER.

### HINTS TO BEGINNERS.

#### WINTERING.

How to winter bees in a way that there shall be little loss has long occupied the minds of bee-keepers. Numerous methods have been tried to effect this, the best being those that kept the bees quiet, such as having the hive dry and free from draughts, without having any intervening space between the floor and the combs, as that prevents the bees reaching the cluster when out airing on a day when the temperature is low. Whatever the form or state of the hive may be it is better to have the combs reaching nearly to the floor, which never should be otherwise than thoroughly dry. Bonar advised suspending hives from the ceiling of a dry room or closet. Another Edinburgh bee-keeper described in the "Farmers' Magazine" about a century since a dioptric hive. He says:—"As to dioptric hives, the best I have seen is of wood in the garden of Mr. George Jarvey at Bathgate. The bees are seen at work in it by opening wooden shutters on opposite glass windows. Mr. Jarvey takes out the honey as he needs it by opening one of these windows, and the hive is perennial, as he never kills a bee. One on a

similar construction has been made some years ago for the writer of this account by Mr. Francis Clark Wright, in Edinburgh, which answers very well. Care must be taken that these wooden hives be well covered with thatch, to exclude the cold air during winter. I have suffered by not attending to this." The advice thus given is sound, and is well worth impressing on the bee-keepers of the present day.

Burying hives has in some instances been tried with success. The bees when immured consume less food than when allowed to remain on their summer's stand. When hives are buried during winter care must be taken that the site is a dry one with a northern exposure, being away from the direct influence of the sun, or of any direct inlet of air. In the house where I live, nearly a century since the hives were wintered successfully in the attics underneath the thatched roof, the only precaution required being to keep them dark. The evil of housing bees is that if light is admitted, or even a strong current of air, the bees will at times leave their hive, going directly to the light or where the inlet of air is, and are lost. The best place for wintering bees I ever saw was in an attic above a dwelling house; but the bees were not imprisoned in any way, but had full liberty to fly out and in at their pleasure. The windows were open, and the hives stood in the centre of the floor. In such a comfortable position the bees were healthy, did not consume an extra quantity of food, and did not seek to fly out when the weather was unfavourable.

The Stewarton system consists in wintering either in houses or in being well covered with straw. The hive has an eke or "raise" from 2 to 3 inches deep. This, however, removes the edges of the combs too far from the entrance. The object of it was to insure dryness. Although this system is very old, "W. R.," in the *Bee-keeper's Record*, gives it under "Improved Wintering;" but another feature of the Stewarton hive he has adopted, after all his condemnatory remarks of it and those who used it. The Stewarton hive is the mother of bee-keeping for wintering bees, and its suitability for storing quantity and quality is yet unsurpassed. It is, therefore, satisfactory to all those who have sung its praises so long to see "Scotland's most advanced bee-keeper" adopting it almost *in toto*, although at a late date; but "better late than never."

The *American Bee Journal* has been giving the opinions of some writers on wintering bees in a semi-dormant state, keeping them so for three months, and without food. Whatever may be the opinions of the Americans on that point, or the effect of the climate on the bees there, we need not trouble much. In this country the more comfortable bees are kept during extreme cold the more likely are they to survive and come out strong when mild weather returns. If bees are reduced to a dormant state, and kept in that state without food beyond a certain period, they will never recover. Bees in a semi-dormant state will endure a certain temperature without being injured, but if a lower temperature is reached half an hour's neglect will destroy them.

The nearest point to perfection in wintering bees in this country is what I have often described in these columns. During the month of September have the hives full size and full of combs containing not less than 30 lbs. of honey, occupied by say from 4 to 10 lbs. of bees, having a young, proven, fertile queen. Cover the hive on the sides with straw or sacking, over which a piece of felt or tarpaulin must be wound about and tied firmly; care must be taken that the felt projects from the upper edge



of the floor, which ought to be a ventilating one—a wide stretch in advance of an empty box beneath. The top of the hive must be covered with a piece of flannel, and over it a good layer of dried grass, and this should extend down the sides as well. A sheet of galvanised iron, bent to a semicircle, and held in position by two wires completes a hive costing, when made by a tradesman, not more than 10s., forming the cheapest and best hive made. As a comfortable domicile for bees and for producing honey in greatest quantities it cannot be improved upon, all other extras only add to the appearance. If the above simple arrangements are properly performed, the bee-keeper need not concern himself about his bees until the months of April or May, further than to widen the entrances as required. These, with the arrangements and hive so described, should not be wider than from 1 to 2 inches. Where no ventilation is provided it is necessary to give more doorway, but remember that cools the interior of the hive, causing the bees to consume more food and producing a greater desire to fly out at an unfavourable time and so be lost. Keep in mind that it is important to have dryness, a uniform temperature of about 60°, plenty of food and air without draughts. During the whole of my life I never had a hive that required the dead bees to be drawn out with a hooked wire, unless in several cases with Syrian nuclei.

#### QUEEN REARING.

A judicious system of queen rearing at the proper time is the best means to ensure a successful issue, and a nearer approach to dispensing with the brimstone pit than all the noise that has ever been made about saving "condemned bees." Keep the hives strong during the honey gathering season, and prevent an undue increase of colonies by swarming. This is most easily effected by introducing young queens to all hives shortly after they have swarmed. Therefore, to have a supply of queens on hand at the proper time should be the aim of every bee-keeper. Either after the first hive has swarmed or the queen of one is deposed (at as early a time of the year as will warrant the act, which may be the month of May, or when drones are likely to be numerous) examine the hive between the eighth and tenth days, just when the queens are beginning to creep out. Have in readiness plenty of queen cages, either made from perforated zinc or wire cloth, I prefer the latter. They are from 1½ to 2½ inches long, and about three-quarters of an inch in diameter, having one end closed with the same material, and a gateway close to it, having a gate made of one piece of wire, scrolled at one end to shut the way, and the other hooked to prevent its turning. The other end is left open, to be closed with a cork or pipe cover, about half an inch down. Two wires are stretched across, which prevents the cork slipping down too far, and supports a bit of honeycomb or candy for the queen to feed on, should the workers neglect her. The pipe cover is called into requisition when food is put in, but the cork when not. As the queen creeps from the cells either catch her by the wings and put her into a cage, or place the open end of the cage over her on the comb, and so secure her, and then stop the open end as described.

There are various ways of preserving the queens—that is, the surplus ones, because some of them ought to be at the head of nuclei, and these are formed by taking one or more combs with bees and brood, placing them in a box suitable in size by using dividing boards, but otherwise the same as the ordinary hive or portion thereof, covered and treated as a weak swarm. There is

no difficulty in getting plenty of queen cells, but there is sometimes a difficulty in procuring a queen when wanted. To effect this, take a tube of perforated zinc the same size as the cage; by a circular motion press it into the comb until pierced right through; now withdraw it, and push the cage containing the queen into the hole. Many may be so placed; but a more handy way is to have a number of frames with holes on the top bar the size to receive the cage with the queen. Each frame may have from three to five holes about 2 inches apart. Place these frames amongst queenless bees and they will attend to them for a long time, or until wanted. There is still another way of preserving queens by putting them into cages similar to those Mr. Frank Benton sends over queens in from the East. After securing the queen in these cages, put them in a pocket where they will be warm. The frames for holding the cages, however, is an admirable plan, and so far as I have seen never been used by anyone but myself. Whenever a hive swarms, at least the following day after, overhaul it and excise every royal cell; then take a frame containing one of these queens (if you have not a fertilised one at hand) and insert in the hive, although I prefer putting the queen into one of my safety cages, which is about 3 inches square, divided into two compartments and covered with glass. Whenever the bees are seen to cling loosely to the partition of perforated zinc between them and the queen, and all loud humming ceased, she may be let loose by drawing the sluice, when the bees and the queen will join and fraternise at once. When putting the queen into this cage it is only necessary to replace the glass with a piece of wood, having a hole to receive the round cage, and put it in and release the queen from the one to the other by drawing the sluice. By following this course all risk as to handling the queen is done away with. The advantages gained by introducing queens are: it entirely prevents after swarms, insures a young queen at the head of the stock in a laying condition at least two weeks earlier than if it had been allowed to swarm, thereby insuring a harvest of honey that otherwise would have been nil. Moreover, if a first swarm is not wanted it may have its queen deposed and swarm returned to stock. In this case, however, a fertilised queen should be given with additional breeding space given at the time. The above is the surest way of controlling swarming and having bees at the right time, a large harvest is insured, and there are no condemned bees.

#### STAND AND FEEDER.

In my various articles I have frequently alluded to the above, but never described it. I will do so now. It is a box the same size as the hive, which may be of any depth suitable to the tastes of the bee-keeper, but must be of sufficient depth to hold frames. It is provided with an alighting board (moveable), and must have a doorway and door the depth of the box at the back. The bottom is solid throughout, but the top must be either nearly, wholly, or partially open for several reasons—such as if a ventilating floor or a large or small feeder is desired. These before me of my own are divided into three—one in the centre open, and the back and front close by pieces of wood half an inch thick. Underneath this is a drawer also divided into three spaces, all of them fitted with very thin floats. The front space is, however, closed on the top by another thin piece. This is for the purpose of preventing bees escaping when the drawer is taken out to be filled with syrup, which may be from 6 to 12 lbs. or more. With all deference to those who differ from

me regarding the utility of float-feeders, I consider them, as commonly made, the worst of all feeders. They warp, and allow the bees to get underneath them, and when refilled with syrup many are killed. To obviate this, the float-feeders I use are cut into narrow strips, a hole is bored at each end of them, and brass screws or pins passed through them into the bottom. These nails guide and keep the floats in place, and warping is impossible with such narrow strips. This sort of stand has been long in use by me for feeding back inferior honey from both the comb and when dripped. When the former is to be fed back the drawer is to be taken out and placed in the bottom, and as there is a trench in the front of the box as well as in the door to receive the ends of the frames right above the drawer, frames or partly filled sections are fed back to a strong colony, and if the honey is of good quality will finish sections with it. To facilitate emptying the combs open the door and put in a sheet of glass, and the bees will clean the honey out much more quickly than if the door were kept shut.

This useful stand can be applied to many purposes. Having a strong moveable lid of zinc it makes a capital seat; if filled with trays holds many useful tools (queen's cages, slate, paper, pens, pencils, ink, &c.), besides if wanted many flower seeds if the trays are filled with little boxes to hold them. During the spring of the year the bottom is cleared out and then makes a capital peameal feeder, while the feeder drawer is converted into a water feeder, being placed upon the lid of the box. All the rest, being well painted, is not affected by the weather. A pair of handles completes this useful adjunct to the apiary and garden, which only a few of the uses it can be put to has been mentioned.

In another article I will touch upon queries in connection with Stewarton hives and supering.—A LANARKSHIRE BEE-KEEPER.

#### TRADE CATALOGUES RECEIVED.

Ralph Crossling, Penarth Nurseries, South Wales.—*Catalogue of Forest Trees, Conifers, Fruit Trees, and Shrubs.*

R. Gilbert, High Park Gardens, Stamford.—*Fruit, Flower, and Vegetable Catalogues.*

B. S. Williams, Upper Holloway, London, N.—*Catalogue of Flower, Vegetable, and Agricultural Seeds.*

Webb & Sons, Wordsley, Stourbridge.—*Spring Catalogue for 1888.* (Illustrated with Coloured Plates).

Sutton & Sons, Reading.—*Amateurs' Guide to Horticulture for 1888.* (Illustrated with Coloured Plates).

James Veitch & Sons, Royal Exotic Nursery, King's Road, Chelsea.—*Catalogue of Seeds, &c., for 1888.* (Illustrated with Coloured Plates).



All correspondence should be directed either to "THE EDITOR" or to "THE PUBLISHER." Letters addressed to Dr. Hogg or members of the staff often remain unopened unavoidably. We request that no one will write privately to any of our correspondents, as doing so subjects them to unjustifiable trouble and expense.

Correspondents should not mix up on the same sheet questions relating to Gardening and those on Bee subjects, and should never send more than two or three questions at once. All articles intended for insertion should be written on one side of the paper only. We cannot reply to questions through the post, and we do not undertake to return rejected communications.

Pelican Chrysanthemum (H. S.).—When exhibited by Messrs. J. Veitch and Sons this variety was considered quite distinct from White Dragon,

but you are not the only purchaser of the former who has found it not to differ from the latter. We cannot explain the reason.

Books (W. Scott).—The volumes, if complete and in good order, are of more than waste paper value. A set recently advertised realised 23s. If you can dispose of yours locally for 5s. each that will be fair to buyer and seller, assuming, as we have stated, they are in good condition.

Removing Greenhouse (A Tenant).—So far as we understand the case you are not legally entitled to remove the house or any part of it, for though it may not be attached to the walls of the dwelling, it rests on masonry, the foundations of which are in the ground, and the house is thus attached to the freehold and belongs to the landlord. *Bona-fide* nurserymen and florists can remove glass structures, as they are part of their stock in trade.

Primulas (Coker).—If we had sent you some of these flowers packed in dry paper they would have reached you in a very different state than when taken off the plants, indeed so shrivelled and crushed that you would not be able to estimate their merits. So far as we can judge, however, from those you have sent, though they do not appear to be superior to many others we have seen, we think they are worth perpetuating, and you may further improve the strain by only saving seed from the best varieties.

Plum Tree Gunning (H. J.).—Gunning, or the exudation of sap, arises from a variety of causes; in your case it is probably, as you suggest, the result of the dry summer, assuming that your trees are not excessively vigorous. Like yourself, we have known fruit trees much injured by shooting bullfinches in them, and you afford evidence that practice is not necessary in reducing the number of these birds, since you have entrapped fifty-eight of them this autumn. Perhaps if you were to describe your method it might be useful to others.

Vines for late Vinery (F. L. D.).—As you require seven vines, and will probably require to commence cutting in November onward to April, we advise Madresfield Court, Mnsat of Alexandria, Black Alicante, Alnwick Seedling, Mrs. Pearson, Gros Colman, and Lady Downe's; but if you do not want to commence cutting before Christmas, then we advise two Black Alicante, two Alnwick Seedling, one Mrs. Pearson, and two Lady Downe's, which are all of good quality. As the border must be flat provide extra drainage, and do not make a deep border; 24 inches to 30 inches is quite deep enough. Crushed bones are the best, using at the rate of a twentieth of the loam, and well incorporating them therewith.

Steamed Bone Flour (J. H.).—This is the result of grinding bones that have had the fat and a portion of the ossein melted out of them by being subjected to steam pressure and powerful heat in a close boiler. When the bones are thus dried they can be ground into finer particles than new bones can, and the action of the manure is quicker in consequence, notwithstanding that the finer and drier flour may contain a little less nitrogen. Perhaps your best plan will be to dissolve them by either of the following methods as may be most convenient:—1, Place 5 cwt. (or twelve bushels) of bone on an earthen floor, surrounded by a rim of ashes; pour on as much water as the bones will suck up, and then pour on 2 cwt. of sulphuric acid; it will boil somewhat violently for a while. When this has subsided it will get tolerably solid, and the ashes and all may be shovelled up together, and will be fit for use in a day or two. 2, Take a large watertight hogshead and cover the bottom with about 6 inches deep of dry soil; on this put a layer of bones of the same depth, and cover them entirely with wood ashes; on these another layer of bones, then ashes, and so on till the hogshead is full, placing a good thickness of ashes on the top. Leave it exposed to the rains all summer and winter till spring. Then on removing the contents of the hogshead the bones will crumble to powder under a slight pressure, and form one of the most valuable manures ready for immediate use.

Manures (H. S.).—The chief constituents in chemical manures are nitrogen, potash, and phosphoric acid in the form of sulphate of ammonia or nitrate of soda, muriate, nitrate, or sulphate of potash, and superphosphate of lime or bonemeal. The advertised fertilisers contain those constituents blended better than you can probably blend them yourself, and are used by most of the leading cultivators. Urine contains all those ingredients. It is referred to in the "Cottage Gardeners' Dictionary" as "Excellent as a manure, but must only be given to plants when growing, and in a diluted state. One of the most fertilising of liquid manures is composed of Cabbage leaves, and other vegetable refuse, putrefied in the urine from a house or stable, and diluted with three times its quantity of water when applied. If mixed with bleaching powder (chloride of lime) there will be no offensive smell. Gypsum mixed with it, or a little oil of vitriol poured in, adds to its utility as a manure, as it prevents the escape of ammonia during putrefaction." Instead of adding three times the quantity of water it would be safer with more than twice that quantity for the majority of plants in pots, and then would not benefit all regardless of kinds, root action, and soil. If you will send your postal address we will endeavour to answer your other question.

Various (F. S.).—1, There is nothing gained by the very early planting of Potatoes. We consider the middle of February in the case of unsprouted sets quite early enough, even in light well drained soils, and in heavy the beginning of March. The soil, however, is usually so wet and cold at those times that most growers prefer to place the sets in shallow boxes, eye-end upwards, to sprout in a place where they will be free from frost, which should be done early in February, deferring planting until the spring (equinox, i.e., March 21st), or thereabouts. We have known Ashleaf planted on Lady-day, and the crop lifted soon after Midsummer-day, realising £65 per acre. The most important item to be attended to with early sets is to preserve the first sprouts, and if properly attended to they will not be more than half to three quarters of an inch long at the time indicated, and will go right away after planting; frosts, of course, sometimes injuring the tops after they appear above ground. Veitch's Ashleaf is a good early variety, and beyond second early it hardly pays to grow Potatoes in gardens, Covent Garden Perfection and Beauty of Hebron being much grown for market. Good-sized sets should be selected, and

they should, unless large, be planted whole. 2, So soon in February as the weather permits is the best time to sow Pass. For early Dickson's First and Best, some preferring William I; a cond early, Gladiator; late, Best of All, Criterion, Duke of Albany, and Ne Plus Ultra. 3, Black Currants bear the best on young wood, giving much the finest fruit; indeed, the only pruning they require is to have the old wood cut out and the young encouraged. 4, It is no use leaving the long shoot of the Vine on the east wall for fruiting; but it will probably do no harm to the Vine, and you can try what experiment you like with it.

**Names of Fruits.**—The names and addresses of senders of fruit to be named must in all cases be enclosed with the specimens, whether letters referring to the fruit are sent by post or not. The names are not necessarily required for publication, initials sufficing for that. Only six specimens can be named at once, and any beyond that number cannot be preserved. (*E. Fisher*).—1, Ne Plus Meuris; 2, Golden Russet; 3, Dumelow's Seedling; 4, Stamford Pippin; 5, Braedick's Nonpareil; 6, Cox's Orange Pippin. (*J. L. B.*).—1, Five-crowned Pippin; 2, Winter Nelis; 3, Josephine de Malines; 4, Vesouzieres; 5, Knight's Monarch; 6, Belle de Noë. (*Henry Mills*).—1, Is Russian Transparent, introduced from Russia into Lincolnshire by General Boncherette. It is quite distinct from Transparent Codlin. We cannot recognise the other two. 3, Is certainly not Omar Pasha. (*Geo. Ashmore*).—1, Cox's Pomona; 2, Court Pendu Plat; 3, Dumelow's Seedling, intensely acid; 4, Cambridge Pippin.

**Names of Plants.**—We only undertake to name species of plants, not varieties that have originated from seed and termed florists' flowers. Flowering specimens are necessary of flowering plants, and Fern fronds should bear spores. Specimens should arrive in a fresh state in firm boxes. Slightly damp moss or soft green leaves form the best packing, dry cotton wool the worst. Not more than six specimens can be named at once. (*F. E. H.*).—*Zygopetalum maxillare*. (*H. K. V.*).—It is *Sericographis Ghiesbreghtiana*, not a *Justicia*. (*R. S. T.*).—It is apparently the bulb of *Amaryllis formosissima*. (*W. P. T.*).—1, *Pteris serrulata*; 2, *Adiantum decorum*; 3, *Erica gracilis autumnalis*. (*B. R.*).—1, *Odontoglossum Ehrenbergi*; 2, *Oncidium Forbesi*; 3, *Restrepia antennifera*.

COVENT GARDEN MARKET.—DECEMBER 21ST.

The improvement in business still continues in view of Christmas, sales all round being readily effected at last week's prices.

OUT FLOWERS.

Holly and Mistletoe are now abundant.

	s. d.	s. d.		s. d.	s. d.
Anthrills, 12 bunches	8	0	Lilies, White, 12 bunches	6	0
Anemones, 12 bunches	0	0	Orange, 12 bunches	0	0
Arm Lilies, 12 blooms	5	0	Lily of the Valley, 12	0	0
Asters, 12 bunches	0	0	sprays	1	0
French, bunch	0	0	Marguerites, 12 bunches	2	0
Azalea, 12 sprays	1	0	Mignonette, 12 bunches	3	0
Bouvardias, bunch	0	6	Narciss, white (E. each) 12	0	0
Camellias, 12 blooms	3	0	bunches	6	0
Carnations, 12 blooms	1	0	Pelargoniums, 12 trusses	1	0
12 bunches	0	0	scarlet, 12 trusses	0	6
Chrysanthemum, 12 bchs.	9	0	Poinsettia, 12 blooms	6	0
12 blooms	2	0	Primula (single), bunch	0	6
Dahlia, 12 bunches	0	0	(double), bunch	0	9
Daisies, 12 bunches	2	0	Polyanthus, 12 bunches	0	0
Encharis, dozen	4	0	Ranunculus, 12 bunches	0	0
Gardenias, 12 blooms	6	0	Roses, 12 bunches	0	0
Gladioli, 12 sprays	0	0	(indoor), dozen	2	0
Hyacinths, Roman, 12	0	6	Tea, dozen	1	6
sprays	0	0	red, dozen (French)	1	6
Iris, 12 bunches	0	0	yellow	3	0
Lapageria, white, 12	2	0	Stephanotis, 12 sprays	0	0
blooms	0	0	Tropaeolum, 12 bunches	2	0
Lapageria, coloured, 12	1	0	Tuberose, 12 blooms	1	0
blooms	0	0	Tulips, dozen blooms	1	0
Lilium longiflorum, 12	6	0	Violets, 12 bunches	1	0
blooms	0	0	(French), bunch	1	3
Lilium lancifolium, 12	0	0	(Parne), bunch	3	0
blooms	0	0	White Lilac, per bunch	6	0

PLANTS IN POTS.

	s. d.	s. d.		s. d.	s. d.
Aralia Sieboldi, dozen	6	0	Fuchsia, dozen	0	0
Arbor vitae (golden) dozen	8	0	Hyacinths, dozen	9	0
(common), dozen	0	0	(Roman), doz.	9	0
Asters, dozen pots	0	0	Hydrangea, dozen	0	0
Azalea, dozen	30	0	Lilies Valley, dozen	18	0
Begonia, dozen	4	0	Lilium lancifolium, doz.	0	0
Capsicum, dozen	0	0	longiflorum, doz.	0	0
Chrysanthemum, dozen	9	0	Marguerite Daisy, dozen	6	0
Cineraria, dozen	0	0	Mignonette, dozen	0	0
Dracena terminalis, doz.	30	0	Musk, dozen	0	0
viridis, dozen	12	0	Myrtles, dozen	6	0
Erica, various, dozen	9	0	Palms, in var., each	2	6
Enonymus, in var., dozen	6	0	Pelargoniums, dozen	0	0
Evergreens, in var., dozen	6	0	scarlet, doz.	3	0
Ferns, in variety, dozen	4	0	Poinsettia, dozen	12	0
Ficus elastica, each	1	6	Solanum, dozen	9	0
Foliage Plants, var., each	2	0	Tulips, dozen pots	6	0

VEGETABLES.

	s. d.	s. d.		s. d.	s. d.
Artichoker, dozen	1	0	Lettuce, dozen	0	9
Asparagus, bundle	0	0	Mushrooms, punnet	0	6
Beans, Kidney, per lb.	0	3	Mustard and Cress, punt.	0	2
Beet, Red, dozen	1	0	Onions, bunch	0	3
Broccoli, bundle	0	0	Parsley, dozen bunches	3	0
Brussels Sprout, 1/2 sieve	3	6	Parsnips, dozen	1	0
Cabbage, dozen	1	6	Potatoes, per cwt.	4	0
Capsicum, per 100	1	6	Kidney, per cwt.	4	0
Carrots, bunch	0	4	Rhubarb, bundle	0	2
Caniflowers, dozen	3	0	Salsafy, bundle	1	0
Celery, bundle	1	6	Scorzoner, bundle	1	6
Coleworts, doz. bunches	2	0	Seakale, basket	1	0
Cucumbers, each	0	4	Sballots, per lb.	0	3
Endive, dozen	1	0	Spinach, bushel	1	6
Herbs, bunch	0	2	Tomatoes, per lb.	0	4
Leeks, bunch	0	8	Turnips, bunch	0	4

FRUIT.

	s. d.	s. d.		s. d.	s. d.
Apples, 1/2 sieve	1	6	Oranges, per 100	4	0
Nova Scotia and	10	0	Pears, dozen	1	0
Canada barrel	10	0	Pine Apples, English,	1	6
Cabs, 100 lbs.	55	0	per lb.	1	6
Grapes, per lb.	1	0	St. Michael Pines, each	3	0
Lemons, case	10	0		5	0



CULTIVATION.

As proof of the severity of the agricultural depression we frequently see statements of the number of acres of land that have fallen out of cultivation under it, and till quite recently we accepted such statements in perfect good faith. It was while we were on our way to a great county meeting with other members of the chamber of agriculture to which we belong, to discuss measures for the relief of the chief industry of the nation, that we had our eyes opened to the fact that, at any rate in the great corn-growing districts, land was regarded as being out of cultivation when it ceased to be under the plough. It may have been laid down to permanent pasture with all due care, and be yielding full crops of forage, yet it was considered to have passed out of cultivation. It was altogether in vain that we protested against such an erroneous and misleading conclusion. No, we were told, when land ceased to be arable land it passed out of cultivation! What would the farmers of the great dairy counties say to such a doctrine as this? Yet we know that in East Anglia permanent pasture has long been held to be a necessary evil rather than a permanent good. On a farm of 300 or 400 acres about twenty acres of pasture, often less, would be, and in point of fact still is, thought quite enough. In one sense we are bound to agree, and that is that twenty acres of mismanaged pasture is so much land wasted. Pasture that is foul with weeds cannot be profitable, and most East Anglian pasture consists of a weak growth of indigenous grasses thickly interspersed with *Ononis arvensis*, and strange to say nothing appears to be done to check the spread of the *Ononis*, yet it is evident that uprooting is the only remedy for such a rampant perennial pest.

Negligence about pastures is not, however, confined to East Anglia. A foul, wet, poverty stricken condition is the characteristic of many a meadow in all parts of the country, and of such land it might well be said that it was out of cultivation. But such glaring examples of carelessness and negligence are altogether beside the mark as affecting the question before us. We know full well that a highly cultivated pasture is now one of the most profitable parts of a farm, and it is surely from ignorance of the advantage to be derived from such care that the term "out of cultivation" is applied to it. In Miss Martineau's charming account of "Our Farm of Two Acres," she tells how by the exercise of care in keeping down weeds and moss, and by an annual dressing of manure, her meadow became conspicuous for its greenness when all the rest of the pasture in the valley was of a uniform hay colour; and she adds in proof of the profit of such care, "There is no hay in the neighbourhood to compare with ours." Since her day we have had permanent pasture taken in hand by men of sound practical ability, and it has been clearly demonstrated that it answers to give as much care in the selection of seeds



and the treatment of the soil for forage as for any other crop. The truth of this must be patent to the most casual observer. If certain sorts of Grass and Clover answer better than others, it is surely worth while growing them and discarding the others; and if by cultivation we can not only increase the ordinary bulk of the hay crop by two or three times, but also materially improve the pasture for grazing in spring and autumn, it is surely worth doing so. How a farmer can allow pasture to be spoilt by Ononis, Docks, Thistles, Rushes, and Nettles in the manner we often see without making some effort to eradicate them quite passes our comprehension; for it is a clear question of profit and loss, and we maintain that every foot of land for which rent is paid ought to be turned to full account.

No sadder sight has met our eyes than land that has really been suffered to go out of cultivation. It had evidently been corn land, for the ridges were still visible though covered with a thick growth of couch grass. Of course it was susceptible of improvement by cultivation, but the vanished or vanishing capital of farmers can hardly be thought of for such work. Land farmed out is not easily reclaimed, as we in common with other land agents know to our cost. Farm after farm have we taken in hand as they fell in upon the estate, and our work has been very much the same upon all of them. First of all drainage, next mechanical division and getting rid of weeds, then storage of fertility. It is possible to do all this in a single season, but the work is so costly and the price of farm produce so low, that it is generally spread over two or three years. In cases where it is not imperative that an immediate return should be had from the land, the most economical way to impart fertility is clearly by a succession of ploughed-in green crops.

WORK ON THE HOME FARM.

The advantage to be derived from clay burning was never more apparent to us than when we were recently walking over some newly ploughed land on a clay farm on the borders of Essex. We have during the last two years spent much money in burning clay there and spreading it on the surface to be ploughed in, and it has now become so well mixed with the soil, that when ploughed after heavy rain it crumbles as it falls over from the ploughshare, thus showing than even the heaviest land may be rendered open to the action of rain and air. We have told before, and it will bear telling again, how that the clay so burnt was originally thrown into ridges when the ditches were made, and it had been so left for many years. These ridges were gradually cleared away and burnt, and we know that the money so spent was a sound investment, for it would be quite in vain to apply manure to the land without some such preliminary treatment. We desire to call particular attention to this matter, because many a farmer has been puzzled about opening up the land fully to the action of sun and air. The ploughing in of half-decayed farmyard manure may do something, but the manure decays, and the soil soon settles down into a close mass again. It can never do so after burnt clay is applied, and the subsequent cultivation of the land is both easy and certain in its effects.

The dairy cows are now having bran, Carrots, chaff, and hay, and some of the delicate Jerseys have an addition of crushed Oats. This dietary is both safe and simple, our especial aim being to avoid anything at all calculated to affect the flavour of the milk. If Turnips are used at all, they are always cooked, and the water strained off, so as to get rid of all unpleasantness of flavour. Cattle Cabbage may be used with advantage provided the quantity is moderate. The cows eat such green food ravenously, and if they have a large quantity the milk is quite certain to betray them by its rankness. Well mixed, sweet, wholesome food now goes far to insure good butter, and if cows can be had to calve in succession throughout winter at intervals of about a month, it will tend to render the butter really excellent in flavour, if a little deficient in colour.

QUALITY, QUANTITY, DEPRESSION.

(Continued from page 488.)

To create a demand and keep foremost place in the world's markets, everything produced must be a combination of the highest quality with a maximum of quantity. If that can be effected and maintained by the home producer, foreign or colonial competition may be defied. Some commodities, of course, the farmer and gardener are precluded from producing so as to compete with imported products satisfactorily, but

no grower need keep "burning his fingers" by sticking to crops which cannot be placed in the market advantageously. If unable to sell Wheat, Barley, and Oats at a profit, what hinders the utilisation of grain in the production of beef, mutton, and pork? Even imported grain might be so utilised, and it would be wiser than grumbling and the persistent sending of raw produce to market when the demand is for the manufactured. The consumption of the raw material—the grass, hay, ensilage, forage, roots, grain, and straw—would have the advantage of maintaining, if not improving, the fertility of the soil, a value as manure equal to that going off as produce, and representing a storehouse capital, from which profits are to accrue in future. Except artificials the land gets little added to its staple where the hay and straw is sold off. It is useless keeping straw, &c., to absorb the liquids resulting from keeping animals; the draining of cow byres, farmyards, &c., are not worth taking into consideration. A few tons or cwts. of artificials are worth very much more than all the manure the raw material consumed at home would produce. Everything goes off the land except that consumed in the manufacture of flesh, and those farms producing most flesh, or having the most animals fed by the crops produced, are in the most satisfactory condition from a landlord's, farmer's, and consumer's point of view. There seems a great decrease in the number of food-supplying animals. The agriculturists decrease the output and are in danger of ruin by the low prices of produce. This in face of a population for the past half century increased beyond home means of feeding. The profits of cultivation are not in raw material, but in the manufactured article. True there must be no falling off in the production of raw material, there must be abundance with which to manufacture a superior article such as none imported can equal, and the farmer can out of our much-abused soil produce crops for which the climate is suitable equal to any, and by their judicious utilisation produce beef, mutton, and bacon superior to any in the world. Rents ought not to be an obstacle, nor yet aids to cultivation. There seems nothing lacking, only the awakening of agriculturists to the responsibilities of their position. They seem paralysed by the low prices of produce, yet the produce of farms, except cereals, brings more money than the best of imported.

There has been depression enough from various causes, but the worst form of it is a depression of agricultural skill, energy, and determination. The land has not been, and is not cultivated. It is foul with weeds—weeds which take as much from the soil as the useful crops, and correspondingly decrease the yield. The culture that returns the most to the soil is the most contributing to present and future crops. Experiments with manure prove that all the land wants is a little nitrate of soda, muriate of potash, and superphosphate. What we want is to return to land as much as possible of that removed. It is Nature's plan; but my object is to show that no additions are of use without the soil being in a proper state of cultivation, so that the crops can abstract the full value from them.

Depression has had its seekers for alleviation. The greatest statesmen have made propositions; farmers have been advised to turn their attention to supplying the markets with fruit and vegetables. Some have done so, and where are they now? The farmers are about as likely to command the markets with fruit and vegetables as the French with fresh laid eggs. The advice was no doubt well intentioned, and sound, too, only no calculation had been made of the farmers' inaptitude and indifference; their best and only schoolmaster is depression. But we may pass the agriculturists as not likely, for at least another generation, to pass muster as cultivators of horticultural produce. True, they may add to the continuance of the uphill work before the horticulturists in the rivalry with imported produce; but there is no fear of the issue with the intelligence and zeal that opposition occasions.—G. ABBEY.

(To be continued).

METEOROLOGICAL OBSERVATIONS.

CAMDEN SQUARE, LONDON.

Lat. 51° 32' 40" N.; Long. 0° 8' 0" W.; Altitude, 111 feet.

DATE.	9 A.M.					IN THE DAY.				Rain	
	Barometer at 32° and Sea Level.	Hygrometer.		Direction of Wind.	Temp. of soil at 1 foot.	Shade Temperature.		Radiation Temperature.			
		Dry.	Wet.			Max.	Min.	In sun.	On grass.		
1887. December.	Inches.	deg.	deg.	deg.	deg.	deg.	deg.	deg.	deg.	In.	
Sunday .....	11	30.082	32.8	31.8	N.	40.3	40.2	27.9	40.3	22.8	0.142
Monday .....	12	30.138	32.1	31.4	S.E.	39.2	49.5	31.8	50.2	29.6	0.211
Tuesday .....	13	29.543	49.3	48.3	S.	39.2	50.9	31.1	51.3	28.1	0.078
Wednesday ..	14	29.553	39.6	37.7	S.	40.9	45.8	34.4	61.2	29.3	0.308
Thursday .....	15	29.301	42.2	40.6	S.W.	40.5	51.9	36.5	52.8	33.3	0.652
Friday .....	16	29.430	51.6	50.3	S.W.	40.8	53.1	39.6	71.6	33.9	0.083
Saturday .....	17	29.893	40.4	37.3	S.W.	41.7	45.8	38.9	62.4	33.1	—
		29.894	41.1	39.6		40.4	48.2	34.6	55.7	29.9	0.819

REMARKS.

11th.—A little snow early, but only enough to whiten the ground; dull, showery day with heavy rain from 11 A.M. till 1 P.M.  
 12th.—Cold, dull, and foggy.  
 13th.—Very warm, dull, and damp.  
 14th.—Foggy early; fine, with some sunshine till nearly noon, then showery till 2.30 P.M. dull and damp after; fair evening; heavy rain after 10 P.M.  
 15th.—Cloudy morning, with slight showers; fine afternoon, bright in the early part.  
 16th.—Wet till 11 A.M., then bright and fine except for one shower in the afternoon and another in the evening.  
 17th.—Bright and fine.  
 An unsettled and changeable week. Mean temperature very near the average.—G. J. SYMONS.



## COMING EVENTS

29  
30  
31  
1  
2  
3  
4TH  
F  
S  
SUN  
M  
Tu  
W

1ST SUNDAY AFTER CHRISTMAS.

### THE CLOSING YEAR.

**A**LTHOUGH the year that is now approaching its termination has not been one of the best that has been experienced by gardeners and horticulturists, it has been brighter and better than some of its predecessors. The most important food crops have been good when high cultivation has prevailed, and no season of recent years has shown the necessity for high culture more conclusively than the exhausting summer of 1887. Imperfectly worked and impoverished land has been comparatively barren, the crops collapsing during the heat and drought, while on land deeply yet intelligently tilled and enriched they passed through the trying ordeal to which they were subjected, and as times go, gave a satisfactory return for the outlay expended in their production. The lessons that gardens afford in this respect ought not to be lost on agriculturists, and it is certain if they were appreciated and applied as far as is practicable the earth would yield a far greater increase than it does now, to the advantage of every section of the community.

In glancing back over the past months, and it is desirable that all should do so, there will, it is hoped, be much that is pleasant for the mind to rest on—good work done by able and earnest men, and approved by appreciative masters; prizes won by those who have striven for them, and honours bestowed for well deserved success; obstacles surmounted by perseverance on right lines that brings a reward sooner or later; differences reconciled by the exercise of good judgment; reconciliations effected between men of different views; and confidences restored that had temporarily lapsed. These are some of the episodes of the season, on which many minds will reflect with satisfaction as agreeable reminiscences of the closing year. Well is it if they are in the majority.

But granting the existence of a large amount of satisfaction enjoyed by owners of gardens and their managers, it is equally certain that disappointments have been incurred and circumstances happened during the year not conducive to general content. Difficulties have presented themselves of a nature that could not be immediately subdued, and some of them not anticipated. Accidents are contingencies of life, and when not the outcome of negligence that might have been easily avoided, should be accepted as what they are. It is useless to waste time and strength and to lose temper over untoward and practically unpreventable occurrences that may be inconvenient and something more, as it is to quarrel with a thunderstorm. The year, however, that is now approaching its termination has not been characterised by storms

of that nature and the heavy downpours consequent thereon; but by the exact opposite—the absence of rain during the summer months, that gardeners amongst others are not likely to forget.

Adequate provision is often made, but not always, for a supply of water for domestic use, while the necessity for cultural purposes is overlooked. No one knows the difficulties attending a scarcity of water in gardens but those who have to endure it, nor the anxiety of mind experienced by gardeners when they see the crops on which they relied dwindling away—time, labour, and forethought being wasted in their production. An excess of rain cannot be prevented, but a water famine may in most, if not all, cases be averted by a well devised system of water storage when it is in excess of immediate requirements. One of the great wants of the times is the provision of receptacles for water capable of holding all that falls from the roofs of buildings in and near gardens in localities where the natural supply is apt to fail, and provision is not made to meet that very serious contingency. If the necessity is forced on the minds of proprietors of gardens, and steps are taken to prevent waste in times of plenty, the disappointment of the past will vanish, and assurance be felt of safety for the future in respect to this most important matter.

Another source of misunderstandings has not been absent during the year—indeed, it has possibly been more pronounced than before—namely, the realised value of garden produce. From causes not far to seek the commercial spirit is abroad, and a widespread desire has been evinced by owners of gardens to endeavour to either make them self-supporting, or to substantially reduce the outlay expended in their management. Reports have been read of extraordinary crops of fruit, and market prices have been consulted in estimating its value, a feeling of “Why cannot we do the same?” becoming established in consequence. “I see we have so many bunches of Grapes in this house weighing so many pounds, and these at Covent Garden prices will fetch so much money; sell the crop, or what we do not want, but don't let the best go.” That is not an unfamiliar instruction to gardeners; but what is the result? This: Retaining the best and selling the relatively inferior brings down the real value of the produce so low that it is scarcely worth sending to market, and instead of 2s. or 3s. a pound expected, perhaps 4d. or 6d. is returned, or even less if the market is overstocked.

Very much the same disappointing results have been experienced by the sale of flowers and vegetables as representing the surplus of private gardens. It is not sufficiently comprehended that such produce as a rule is below, and often far below, the best grades grown purposely for market, and only the best can bring even fairly good prices. It should also be remembered that garden produce of whatever kind may look well at home, but when placed by the side of that of the best trade growers in Covent Garden loses value seriously by comparison, and may be and often is practically unsaleable.

It requires to be further stated as a matter of considerable moment to “private growers” and their employers that the published prices of wares in Covent Garden cannot be taken as a safe basis of computing the value of crops at home. Granting that the prices are as accurately recorded as possible, there is such an extraordinary difference in the merit of consignments when placed on sale that it is quite impossible to estimate their value in advance. And not only so, but the supply

fluctuates so greatly, that the prices for certain articles may be 50 per cent. lower to-morrow than they rule to-day. Nor does that fully represent the case and the difficulty, for it is not unusual for a variation of from 20 per cent. to 40 per cent. to be observed in three hours. Ordinary gardeners selling the surplus produce which they grow are placed at an enormous disadvantage with trade growers, who are so to say on the spot, and make their forecasts accordingly. It is well that these facts be made known, and they are mentioned with the object of reducing misunderstandings between master and man, and preventing in some measure disappointment to both in the coming year. This is a great subject, which must be dismissed at present with the remark, which is more accurate than all the price lists, that it is practically useless to send second and third-rate produce, the surplus of private gardens, to Covent Garden Market.

Taking a broad glance over the world of gardening it is gratifying to observe the great interest that is manifested in the introduction of whatever renders the pursuit more agreeable and satisfying, also in everything that tends to promote superior culture. It is true we have had no grand national or international horticultural exhibitions during the year to absorb universal attention; nor are they needed for affording evidence of the existence of a deep and widespread sympathy with the work in which readers of this Journal are engaged. A growing tendency to decentralisation is apparent in the representation of horticulture. District vies with district and province with province more and more, each striving, and properly so, to attain the greater excellence, hence the spirit with which local associations are promoted and provincial shows encouraged; and taking these into consideration, and they cannot be left out, an aggregate is arrived at, both as regards the number and value of the prizes competed for and the character of the produce exhibited that has not been excelled, if equalled, in any previous year.

Greater zeal than ever seems to be apparent among the working bees in the hive of horticulture, in the formation of gardeners' improvement associations, which have more enrolled members than at any previous time. This is most creditable to British gardeners, and an unique feature in domestic service. We find no improvement societies organised by footmen, butlers, coachmen, and gamekeepers, with the object of rendering themselves more competent in their vocations. This is peculiar to gardeners, and we claim for them merited recognition. Every inducement should be given for probationers to join in those assemblages, first as listeners, then as contributors of matter for discussion. These mutual improvement meetings are true "schools of gardening" that cannot fail to be the means of spreading knowledge, made sound by close sifting, and therefore beneficial to those who have the opportunity for acquiring it.

In numerous other ways, and through other agencies, that will probably be brought under review by qualified observers, the closing year denotes advance rather than retrogression in the delightful and important pursuit of horticulture; and though we cannot forget those who have laboured so long and so well, and now called to their rest, we can rejoice in veterans still with us, and in the uprising of young men who will creditably join in the furtherance of that in which writers, readers, and editors are mutually engaged—the art of cultivation.

A consciousness of the exercise of honest effort, the accomplishment of good work, and the recognition and appreciation of commendable endeavour, convert into

reflective pleasure the toils of the past, making for those who have striven to that end what it is hoped they have just enjoyed

#### A MERRY CHRISTMAS.

#### CAMELLIAS IN MIDWINTER.

Now that Chrysanthemums are over and many other flowers recently plentiful are becoming scarce, Camellias are rising in value, and a good supply at midwinter will give the greatest satisfaction, whether the flowers are for home decoration or market purposes. So far as I can judge at present the summer and autumn of 1887 suited them admirably, as the bushes made good growth and formed abundance of flower buds, which are opening freely. Some growers cause their Camellias to bloom in October and November, but the flowers are not so valuable then as now, as other flowers, both in the open and under glass, are moderately plentiful in those months, and the Camellias do not open so well then as at this time. A bush that might only open four or five dozen flowers in October would readily develop three times that number at present, and although it may be considered early for a full display of Camellias, they are by no means unseasonable now, and all will develop readily. I do not like the idea of forcing Camellias, as this term is applied to vegetation generally. It may suit in some cases where the plants are growing in structures heated with hot water and where the temperature and atmosphere can always be kept agreeable, but forcing does not suit them well in houses heated with flues, and in all cases the less artificial heat applied to them the better. In some years we have tried to force them by giving them plenty of heat in November and early winter months, as it is important that we have them in bloom in December and January, and after that we have generally discontinued the fire heat, with the result that many buds fell with the artificial heat, but when left cool they immediately ceased falling and the flowers came out well. I am referring to plants growing in a structure heated with a flue, but as the weather has been very mild with us of late we have not put the fire on and the flowers are opening more freely than we ever saw them in December. We have therefore no difficulty in seeing that where the buds are well forward they open best at present without artificial heat.

Camellia buds falling is an annoyance which almost all cultivators experience, but some to a greater extent than others. It is occasionally produced by natural causes; but, as a rule, by mismanagement. Excessive fire heat will cause it, and so will excessive dryness at the roots. Plants with their pots full of roots are very liable to suffer. They may be watered most carefully always, but a slight dryness once or twice, which is liable to occur sometimes in cases where no neglect was intended, is often sufficient to bring them off, especially if it happens when they are of a good size or about to open. If the pots can be plunged some little time before the plants are expected to bloom, it is a great advantage, and the greatest care should be exercised in watering when the critical time arrives. If they occupy a conservatory where the hot-water pipes may be under the shelves on which they stand they would be much better moved from there and placed on or in a bed, if such exist, as their surroundings there will be more cool and conducive to their success. Where they are planted out the greatest care should be taken that the border is moist. If the soil is well drained it is almost impossible to give too much water when the plants are coming into flower and throughout that period. A close atmosphere is not in their favour, and as the atmosphere of most greenhouses and conservatories is kept closer now than further on in the better spring months, extra caution is necessary to prevent the atmosphere being too close, but by admitting a little fresh air in the best part of fine days this evil may be readily remedied. Damping the foliage with the syringe to moisten and soften the buds is more necessary in cases where fire heat is used than where that is dispensed with, but in times of severe weather, when fire heat must be used, they should be moistened once daily, but avoid letting the water fall on the pipes or the flue and give them a steam bath, as this is never acceptable to them.

Beginners in Camellia culture sometimes buy small plants from a nursery during the summer or autumn and expect these to bloom freely at Christmas, but there is no gain in such a practice, as small plants are much better not forced in any way, and if they are kept back and not allowed to flower until the spring months, say Easter, they will improve quickly, and become larger much sooner than if they flowered at midwinter. Hardly anyone grows Camellias to bloom at this season without desiring to cut the flowers, and they are rarely taken off without a portion of growth being taken with them. This is often more advantageous than harmful in the case of large bushes, but where the plants are small and in pots it frequently checks them severely. The best way of dealing with



these is to take the blooms off carefully without any wood and wire them to stems.—J. MUIR, *Margam*.

CAMELLIAS generally commence losing their buds during the month of October, or very shortly after the plants have been brought in. Those who turn their plants out in summer often push them on with heat in order to secure early flowering, which induces buds to fall, certainly meaning disappointment, especially with small plants. I will endeavour to explain some of the causes and the best modes of prevention. Those that require early flowers should make these provisions in the spring season by placing the plants required into heat as soon as they have flowered in order to get their wood made early and the buds set. During the growing period liquid manure should be used twice a week. Sheep manure is the best, or a surfacing of droppings is also good. The plants succeed admirably in a vinery if the Vines are not too thickly planted, but insufficient light causes a weak growth.

When the buds are set the plants should be removed to a cooler house for a few weeks to harden the wood previous to being placed outside, which should be in the beginning or middle of July at the latest. Select a place where the plants are protected from the direct rays of the sun during the middle of the day. The shade from trees where not too closely planted I have found to suit them admirably. The plants must not be left out after the middle of September, but when housed give all the air possible for a month or so. The plants should be thoroughly syringed twice a day from the time they are turned out till the middle of October. This prevents the buds becoming too hard. I have found that by placing the plants in the full sun, however much water is given at the roots, the buds suffer, and in consequence they do not open so freely. Good drainage and plenty of water are essential to secure the buds. I believe in many cases failures are caused by plants not having enough water or by insufficient drainage, and plants thus treated should be in full flower in ordinary seasons by the end of December if kept in a temperate house or conservatory after the end of October. If the house should be planted with Camellias, afford some shading with *Lapagerias*. Syringing in this case must be maintained, especially through July and August, early in the morning and late in the afternoon.—J. P.

### LEAF SOIL.

THIS is a valuable commodity in all gardens. In propagating it is as useful as sand, and almost all plants in pots are benefited by its use. It is also excellent in the kitchen garden and flower beds, and as a winter covering it is equal to the more expensive cocoa-nut fibre. It is, however, more in propagating and potting that it is used and valued, but it varies in quality, and much that would turn out first-rate is rendered next to useless by the treatment it is subjected to. In many cases it is thought so long as it appears to be leaf soil that is all that is necessary, and the leaves are frequently used for hotbeds and other purposes before they come for potting. Indeed, this is considered the right way to convert them into mould. It is certainly one way, but far from being the right way; on the contrary, it is the worst plan possible, as the fermenting bed reduces it to mere waste. We have used it often from Pine pits and never felt satisfied with the result, but after receiving a hint from our friend Mr. J. Wright as to not fermenting it, we have ceased doing so, and the result is a material which may be put to the choicest plants without producing fungus or any other deleterious matter. We have abundance of leaves; we could collect a thousand cartloads from now until March. They are chiefly Oak and Beech, and these are the best of all; but we not go far afield for our leaf soil, but collect it quite close to the garden. We do not gather the leaves into a large heap to ferment as is often done, but we collect several cartloads into a hollow and spread them out in a layer about 18 inches or 2 feet deep, and there they remain without fermenting until they decay naturally. Those collected in this way about this time last year are now in splendid condition, and by storing a quantity in this way annually there is no difficulty in securing a constant supply of leaf soil. I can recommend this system thoroughly.—A. G.

### PRUNING THE GOOSEBERRY.

PRUNING, although understood by professionals, is not so by thousands of amateurs and untried men. For the latter class I intend to offer a little plain advice detailing the practical minutiae which belong to pruning. It may be here observed that some classification of the bushes is necessary in order to understand the question aright. The following points may serve to classify them:—1st, Mode of growth. 2nd, Age of bush. 3rd, Vigour of the bush.

As to the mode of growth, it must be tolerably obvious to most

Gooseberry growers that a drooping tree whose points touch the soil should not be pruned exactly similarly to one that grows upright. As an instance of the former I may quote the Warrington, and of the latter the old Champagne. Gooseberries are seldom trained on stems sufficiently tall in the nurseries, especially the drooping kinds, which should, in my opinion, be on stems a foot high at least. I will now proceed to the details of the pruning, and will suppose the first case to be a drooping bush, such as the Warrington. In almost all cases of Gooseberry pruning, thinning out is the first operation; but I have had cases of strong-growing droopers in which it was expedient to have recourse to the hedge shears previously to venturing in with the knife. By removing many of the tips of the shoots with a light hand the knife may be passed freely amongst them, and the thinning out performed both with greater ease and precision. It is an established maxim to keep the centre of the bush very open; for thin how we may, it is almost sure to become filled up during the following summer. Indeed, under all circumstances, it is far better to depend for the crop on those exterior portions which are exposed to the light than on any amount of interior shoots.

In looking carefully over the interior of the bush many shoots of the past summer may be perceived, which, springing from old spurs of former years situated on the main branches, are forced up perpendicularly, or, indeed, sometimes converge. Most of these are useless, and nothing can justify the retention of many but a lack of exterior shoots. Every shoot should assuredly be pruned away which springs up in the very centre; for in a well-pruned tree, when finished, there should be a hollow cylinder kind of opening down the middle of at least 6 inches in diameter—that is to say, in trees of any size and age. After this, what spray is left should be about 6 inches apart in the interior, and so selected as to point rather towards the outside of the tree.

Now we come to the thinning out of the outside portion, for this, too, must be carefully thinned; not so much, however, as the interior, as before observed, for on all that freely presents itself to the light I depend for my principal crop. It is well here to observe, however, that in the event of very late and severe frosts, and when the Gooseberries are just coming into berry, I have sometimes known the chief of the crop in the interior of the bush. I may here at once offer an opinion as to the average distance at which the young shoots should be left; but, as kinds differ so much as to mode of growth, a few preliminary observations will be necessary. Some of the huge "show berries" produce foliage of an enormous size, as also much longer and stouter footstalks to the leaves. Many of our best dessert berries, such as the Early Green Hairy, the Pitmaston Green Gage, the small Early Yellow, and the Champagne, are just the reverse—small, round, and compact leaves on the smallest amount of footstalk. Need I inform the reader here that on the shading character of the foliage should depend the distances at which the shoots should stand apart? Supposing, then, in order to assist those who have indistinct ideas on this subject, that a bush in question has abundance of young shoots to thin, that it is a very large kind, and that the object is the largest crop of the largest berries, 6 inches I should consider an average distance: but if required for exhibition I suppose our Gooseberry fanciers would thin them to at least 9 inches. But be the kind one of those very small dessert sorts before alluded to, and 3 to 4 inches may suffice. As for the intermediates, which will, indeed, comprise by far the most numerous and most useful class, I should give 5 inches as the most useful on an average. In thinning out it is necessary to prune close to the main branch, unless it is a very lean tree, and requires to be excited to make wood; this, however, argues previous mismanagement or an ungenial soil. If the bushes be not pruned close the sure consequence is a profusion of stem-shoots in the interior, which will not only give the workman a deal of trouble in the ensuing year, but must detract from the general powers of the bush.

We come now to the shortening process, which will complete the pruner's labours for the present. If I were required to lay down a rule for shortening it should be this:—Prune away all that you think the bush cannot consistently sustain in its present position without drooping on its fellow shoots. There are many reasons, however, why we should occasionally deviate from this rule, bending to circumstances too important to be slighted. I have before observed that the young shoots of Gooseberries dip or form curves of very different character; this is one reason why shortening should differ. Another may be found in the fact that the extreme points of some shoots are very imperfect, whether through blight, unripeness, or leanness. Here, then, is a reason for removing at least the defective portion. As an average guide to the inexperienced I may, however, say remove something near one-fourth part of the whole length of young spray.

The bushes are now pruned; but are the operator's labours...

entirely over? I answer, No! Have we forgotten that sad pest of the Gooseberry, the "caterpillar?" As this pest in its transformation is understood to take to the soil during the winter I advise those who have time to pursue the old practice of burying the surface soil around the bushes. This is done by opening a trench around the bushes at about 2 feet distance, and paring all the surface soil over the roots of the bushes into the trench, removing about 3 inches. This must be stamped down; and here an opportunity occurs of introducing some manurial matters, as also of covering the surface of the roots thus robbed with a surface-dressing of any kind, according to the needs of the bushes.

Before quitting the subject of Gooseberry dressing, which is, doubtless, better accomplished in November or December than at any other time, for a double if not a triple reason, I may here point to a practice which, although somewhat at variance with established principles, is an expedient worthy of a moment's consideration by those who have suffered much from the depredations of insect enemies, the frost, &c. It consists simply in leaving an extra quantity of young spray in the bushes, in order to provide against contingencies. Those who do so, however, must lay their account with confusion in the bushes, unless they wait on them the moment the crop is secured. The attention requisite will consist, of course, in thinning out superfluous shoots, and, doubtless, in preferring to remove the barren ones.—N. R.

### BOUVARDIAS.

ALTHOUGH not possessing the massiveness of the Camellia, the effect of the Poinsettia, the brilliancy of Duc Van Thol Tulips, or the fragrance of Roman Hyacinths, the Bouvardias are valuable winter flowers, especially those of the Vreelandi, candidissima, and Hogarth types, and they have few equals at midwinter. I have seen them in flower before the summer was well over, and they are often very plentiful in the autumn. But plants which bloom then do not, as a rule, flower freely at midwinter, and it is very much better to have them in flower now than three months ago. I approve of pinching all the joints out until August or early in September, and then allow them to make growth, which will flower for the first time in December.

Plants which bloom early may be kept in flower in a strong heat during the winter, but this is an expensive way, and cannot be practised by the majority of growers. There is, however, no difficulty in getting them to bloom for two or more months at a time, and the plants which come into flower in December will give a succession until the end of January or later. They are not exactly stove plants, neither will they succeed in a cool greenhouse, but an intermediate house or pit suits them admirably. They should now be kept in a light position, but they must not be too close. We have plants blooming at the present. One is in a close low pit with a temperature of from 65° to 70°, but in another pit with a similar temperature, only in the latter case the atmosphere is much more airy, and here the flowers develop with more freedom, gain better size and intenser colours, remaining much longer in perfection than those in the close atmosphere. We would have them all in the airy place, only there is not room for them, but if any of your readers have their plants in a close place and can give them more airy quarters, they will soon find them improve.

I consider them semi-hardwooded plants, and for this reason they do not require much liquid manure, especially if it is manufactured from hot artificials, such as guano, but liquid from the manure heap does them good. It will be noticed that the main points open first with some little side shoots further back that are later. If the whole shoot is cut off these unopened buds are lost, but if the piece that is in flower is cut with a short stem, and the others allowed to remain, they will soon flower, and if the plants are young and vigorous they will go on producing more shoots and flowers as the points are cut out. Green fly is apt to take possession of them at this season, and it stops the progress of the plants to a ruinous extent, but fumigation or a sharp syringing will always render them clean. Bouvardia flowers remain fresh a long time when cut and put in vases, and for buttonhole flowers and choice bouquets they are superb.—WELSHMAN.

### MANURE HEAPS.

"WELL, what of them?" someone will say. "Surely everybody knows all about such a common matter." Perhaps so; but they do not always act as if they did, and one of the most simple and beneficial process to which they could be submitted is neglected as a rule. The aim of all is to secure a rich manure. No matter what ingredients are mixed so long as the heap is rich, and stable manure is the freest from grubs and insects of all, but that from the pig-sty and other sources is often a mass of grubs. These, if allowed

to exist and be dug into the soil, or even put on as a top-dressing, will interfere sadly with the success of many crops, such as Onions, Carrots, and Celery. It is no uncommon thing to be told, especially by amateurs, that their garden soil is full of worms, and in nine cases in every ten it is the fault of the manure. If this were properly prepared before being placed in the ground, we should hear less of grubs injuring crops. Winter is the great time for getting manure heaps ready for spring use. All kinds of tree-leaves, garden refuse, and odds and ends of every sort are collected together in most gardens to make up the necessary quantity, but we object to their being put on our soil without being purified, and this is very important in all cases. Lime must never be used in doing it. Salt and soot are the two best purifiers, and a quantity of one or both should be used in all mixed manure heaps. The manure may all be mixed together first, then throw soot over the top and begin turning the heap over. As this goes on, throw more soot in the centre, and work it in so that it will reach all parts. Salt may be used in the same way, only not in such large quantities, and if all who are troubled with worms in their soil, or at their roots and plants, would adopt this plan they would very soon be gratified with the results.—A PRACTICAL GARDENER.

### RAPID GRAPE PRODUCTION.

I SEE by the column of correspondence mention is made about growing and fruiting Vines in pots from eyes within a year. If information is wanted of a similar experiment I can supply it. On the 1st of May, 1865, I put in some eyes of a few different varieties of Grapes, and grew eighteen plants of them, ripened the canes, started them into growth again, and ripened the fruit on them by the 1st of May, 1866, and sent some to table on that day. Two of the Vines were reserved for the International Horticultural Exhibition held in that month, and were awarded a first prize. Any person possessing a catalogue of that show will find it entered therein. They were so much admired that they were, after the show was over, placed on the table at a large dinner party given at a mansion at Hyde Park Gardens, as I took them myself.—THOMAS RECORD.

### THE INSECT ENEMIES OF OUR GARDEN CROPS.

#### THE GRAPE.

(Concluded from page 365.)

AMONGST the smaller beetles belonging to the weevil tribe few, perhaps, are so persistently annoying to the gardener as those of the genus *Otiorhynchus*, and it is their habit to attack both vegetables and fruit. Of *O. sulcatus* I have received many specimens this season, as it has been abundant in many places, some persons thinking the old insidious foe was a new enemy. From its occurrence upon Vines this has received the popular name of the Vine Weevil, and its relative, *O. picipes*, that of the Clay-coloured Vine Weevil. This is a smaller and less common species, but of similar habit. The female insect deposits her eggs on or just below the surface of the earth, and the larvæ or maggots feed on the roots of various plants, preferring those of succulent habit, and feeding, with little intermission, from September to March. Young and tender plants are frequently killed by them. That they sometimes feed on the roots of the Vine is certain; the injury there, however, is not so marked. These maggots are plump and pale, having a distinct head, but no feet, the body studded over with short hairs, which aid them in locomotion. When they are exposed to view they always assume a curved posture. During the spring they are quiescent as pupæ, and the beetles appear upon Vines or on other fruit trees in early summer, continuing to be about until July. Concealing themselves by day, they find plenty of nooks under the bark of old Vines or in the crannies of walls, and then swarm after dusk upon the leaves, though they do not touch the fruit. As the least alarm causes these beetles to feign death, they may easily be shaken off the twigs, caught in a cloth held beneath, and then disposed of. This weevil is distinguished from its brethren by the raised lines on the body, which give it a glossy appearance, though the colour is a darkish brown. When the presence of the insect is suspected in gardens or houses many of the pupæ may be killed by removing the surface soil along walls or round trees in the spring. Miss Ormerod recommends this plan for infested Vine borders; and watering with ammoniacal liquor, petroleum solution, or decoction of quassia are also remedies. In some seasons the Apricot weevil (*O. tenebricosus*) has been found at Vine roots, more generally at those of shrubs and vegetables. The beetle has reddish legs and a body covered with yellow down. It emerges earlier than the others, and attacks buds or young shoots of the tree from which it is named, also those of the Peach, Plum, &c. All these beetles are unable to fly, but they are strong, as are the maggots, which defy cold and damp better than many insects.

The Lisette, La Bèche, or in science Rhynchites Bacchus, is a name of terror the other side of the Channel from the great injury it does some years to the young leaves of the Vine. It is an English insect also, but with us it confines its operations chiefly to the Apple, the newly set fruit of which is attacked and the egg of the weevil placed therein; and it occasionally visits stone fruit, piercing to its very centre. But we have another weevil, fortunately not abundant, which follows the same method on our Vines which the Lisette pursues on those of France. This is *R. betuleti*, a little beetle of a steely blue, about a third of an inch long, and with an abdomen almost square. It appears on the Vine in April or May, seldom entering houses. The female insect begins the mischief, and the maggot completes it. She tears down a leaf with her rostrum, commencing at the tip, and this loose portion of it she ingeniously rolls over the other, and the juices exuded bind it into a small mass. Then several eggs are thrust into the roll, and the operation repeated until her stock is exhausted. The maggots hatch speedily, and are full grown in about a month, when the leaf, which has then withered, falls, and they bury themselves for their transformation. There is no remedy save the prompt removal of any leaves seen to be rolled, and these are generally conspicuous enough.

Coming now to the Lepidopterous order of insects, it is notable that of the larger caterpillars none are known to feed habitually upon the Vine. Some years since I received some of the gay coloured horned caterpillars of the elephant moth (*Chærocampa elpenor*) which had been discovered in a vinery, much to the astonishment of the owner, but this was quite an exceptional instance. The caterpillar pests of the Vine are mostly small. On the Continent, however, their numbers and prolificness make them highly injurious. At present we enjoy a comparative exemption from them. Some difference of opinion exists as to which is the worst. I am inclined to think the bad pre-eminence must be given to the species long known as *Tortrix vitisana*, now styled by entomologists *Cnectra pilleriana*. The moth is remarkable for the great length of its palpi or feelers. In colour it is brown or greyish brown, with a slight metallic gloss on the fore wings. Its caterpillar is not particularly distinguishable from several others of the tribe, of a dull green, sprinkled with whitish warts, and slightly hairy. In April and May the females settle upon the twigs, where they place their eggs singly. When these are hatched the young caterpillars are found drawing the flower buds together by means of threads, and they destroy all that they attack. It has been noticed that the Vine suffers most from this insect in cold and damp springs. Early in August or sooner, other caterpillars appear of the second brood, and these feed upon the Grapes, ripe and unripe, covering the bunches with webs. At their maturity they bury in the earth sometimes, or else place the cocoons in other hiding-places. It has been thought there are three broods, but I believe it is more probable that there is a successive emergence of moths from the first brood, so that the young caterpillars may be found on the newly formed Grapes, and also, later, upon those nearly ripe. In England this is accounted a scarce and local insect. The only unquestionable habitat is the Isle of Wight, where observers report it is attached to the Stinking Iris, which seems unlikely. During 1880 the Vines growing in East Cliff Gardens, Lincoln, suffered severely from a host of caterpillars, evidently those of some *Tortrix*, but the species could not be verified by any entomologist, as none of the moths were reared. I am almost convinced this was an appearance of *C. pilleriana*, yet it might have been the species next to be described which has been an occasional troubler of our Vines in the south.

As an enemy of fruit trees in spring the larva of *Ditula angustiorana* is familiar to many gardeners, and to the Apricot it is specially partial, hundreds or thousands of these being sometimes found on the walls, living in and devouring the young leaves. This caterpillar is of a dull green, or else yellow green, with the head glossy, behind the eyes a black mark, on the back are four brown spots, darkest in their centres, and separated by the dorsal line into pairs. About July the moth appears, measuring six to eight lines across the expanded wings, which are brown, varied by markings of a deep red or chestnut brown, speckled also with black, the chief markings being edged by scales of golden tint. At Kew and elsewhere larvae of this species have been found devouring the Grapes in August, descendants evidently of the summer moths, a circumstance which has much surprised entomologists, but we are hardly in a position to say whether it is exceptional or usual. Should this prove to be a frequent occurrence, it may be also the case that the Vine flowers are attacked by some caterpillars of the first brood. Or we may find that the second brood is a variety occurring only in some seasons, for it is not generally noticed as yet, but at present we are scant of information about it. On the Continent *O. roserana*, also called *Eupæcilia ambiguella*, feed upon the Vine flowers in May, sometimes devastating whole districts. In Britain it is a very un-

common insect and does not appear to feed upon the Vine. Other species of the *Tortrix* family are common on the Vines of Europe, those especially that are not under glass, their multiplication being favoured by a more genial climate than ours, which if it is unkindly to the Vine is also prejudicial to its foes.—ENTOMOLOGIST.

### AN ARTIFICIAL MANURE.

I HAVE often thought that an artificial manure might be brought out that would supply nourishment without smell, colourless when mixed with water, not injurious to the leaves of plants when syringed on them (*i.e.*, by leaving a deposit), would not sour the ground by continued use during growth; in fact, plants will grow in nothing but sand, watered with this liquid. It has also another good property, it renders hard water soft.

As an amateur I used this mixture last year with the most gratifying results. I now want a few other persons to try it, and have asked the Editor of this Journal to make it known and use his discretion in the distribution of 1-lb. packets. The 1-lb. packet will, with 2½ ozs. of commercial nitric acid, make 160 gallons of liquid manure. The best way to mix the powder is to place it in a gallon jar, then add the water, leaving enough room for the 2½ ozs. of commercial nitric acid. Shake the jar until all is dissolved, and when you wish to use the manure put 1 oz. from the jar into each gallon of water. I have used the above to water Orchids, but if anyone wishes to use it in this manner I will answer them through this Journal. My impression is that once used always used. It also cleans the leaves of plants that have become coated with carbonate of lime from use of hard water.—DUM SPIRO SPERO.

### CHRISTMAS ROSES.

THESE cannot be grown satisfactorily in many districts, much depending upon the nature of the soil and subsoil. A rather strong loam resting on a clayey subsoil appears to suit them well, and nowhere can they be found in such quantities and vigour as in the neighbourhood of Bath. Acres of them are grown specially for producing cut blooms, these being sent all over the country, and pay well. All are improved by protection, either by frames, handlights, or light houses; in fact the greater part marketed are thus protected. In the open ground the larger variety, *Helleborus niger maximus*, is seldom fully expanded at Christmas, but the smaller form is earlier. Both have longer footstalks, and are of a purer white under glass—another good reason for affording them this protection. Unfortunately this usually necessitates wholesale lifting and replanting under glass, or it may be potting a few. This greatly weakens them, and it takes at least two clear seasons to refit them for lifting again. By this it will be seen three sets of plants are needed, all being lifted and gently forced in their turn. They seldom pay for being kept a second year in pots, and our plan, and that also practised by the market growers, is to freely divide them after flowering, and plant them afresh in rich garden soil. If duly mulched and watered in dry weather they soon attain a serviceable size, and in our estimation are simply invaluable. At the present time we have plants in 10-inch pots carrying as many as sixty beautiful flowers.—B.

### STRAWBERRIES FOR FORCING.

THE time for forcing the above fruit will, ere now, in many places have begun. Many growers will, owing to the late hot summer, have but second-rate plants as compared with plants grown in previous and more favourable seasons, although for my part I am well pleased with my plants. True, I have had others larger as regards foliage in previous years, but never better rooted and ripened than at the present time, and this I attribute solely to not layering the runners. I have never been fortunate in having more men than I knew what to do with, and the common practice of layering I could never see the use of. In my younger days I have seen many a fine runner spoiled by being layered in small pots and allowed to suffer by want of water. My practice is to obtain rooted runners, and in good loam pot them at once into their largest pots, and if possible place them close together for a few days under the shade of a north wall; syringe twice a day for ten days, and afterwards expose them in the open. Such runners will start right away upon recovering from the slight check, and with attention to watering, by October such runners will be fine strong plants, their roots having filled the pots.

Many gardeners place their plants under cover to protect them from heavy rains. If the drainage is good and the pots well filled with healthy roots heavy rains will not hurt them. My plan is to cover outside Peach and Vine borders with stable litter or bracken, and by the end of October plunge all Strawberries to be forced in litter on these borders, never in any way protecting them. Should



frost, snow, or rain come, it will not injure the plants, this slight protection to the roots being all that they need. They are ready at any moment to do their duty when forcing time comes.—SOUTHERN ALL-ROUND GARDENER.

### NOTES ON TOMATOES.

1887 will always be remembered by me as a year when we had extra good Tomatoes, and plenty of them. I have grown Tomatoes for many years. Indeed, as a journeyman I had charge of some which were not grown for use or profit, but only as ornament, and by many they were looked upon as being as dangerous to eat as Toadstools; but times have changed since then. It is a pleasing plant to grow, as the fruit is very beautiful when well and freely produced. I have had very extensive collections of Tomatoes; but I am tired of them, and during 1887 I have tried a careful selection. This, I think, partly accounts for the abundance of fine fruit we possessed during the past season and so late as a fortnight ago. The variety which has served us remarkably well is Webb's Sensation. In May last I noted how exceedingly well it succeeded in pots for the early spring crop, and it has been excellent ever since. Its leading features are a robust compact growth with clusters of fruit at every joint, and every one of these are quite smooth and of a fine red colour. Some have been gathered as smooth as a cricket ball, and 18 ozs. in weight, and large quantities or the majority weighed 8 ozs., and the flavour is excellent.

It is often said that large fruits may be good in the kitchen but inferior to use uncooked, and this may be so in some cases; but I cannot understand a Tomato being first-rate cooked and inferior when uncooked. Small fruits may be more desirable for salad or dessert, and in that case Messrs. Sutton of Reading possess a little long clustering yellow one, which is sure to meet with the approval of all. Carter's Greengage is also excellently flavoured, raw or cooked.

In coming to remark on culture, I think a common mistake is made in giving Tomatoes too much soil to root in. It is astonishing how very little soil they will succeed in. The plants above referred to have not more than a peck each. This quantity was placed on a little mound on a stage in a low pit when the Tomatoes were planted at first, and they received no more until September, when a surfacing of horse droppings was given them. This small quantity of soil prevented their making superfluous growth at any time, and this is an advantage, as when they make a great mass of wood they are not so much disposed to fruit as when only inclined to make one strong stem. They fruit more freely in a small quantity of soil, and it is an easy matter to feed them with liquid manure when it is noticed that they require this. Indeed, I would undertake to produce better Tomatoes and more of them in a hat-box full of soil than in a wheelbarrow-load. Those who allow their Tomatoes to ramble about and form an endless number of shoots and leaves will never secure a first-rate crop of fruit; but if they are always kept to one stem the crop will invariably be a profitable one.

As it is impossible to have Tomatoes ready too early in spring I have no doubt there are many of your readers now anxious to cultivate their plants in such a manner as to get them to fruit in March and not later than Easter, and to produce a good crop at these times we have found cuttings rooted in autumn by far the best. They may be rooted in small 3-inch pots, and they may be kept in these until about the new year; but to secure early fruit they should be placed into 6-inch pots as soon as possible, and after being grown in these for a few weeks they should be transferred into 8-inch or 9-inch pots for fruiting. If confined to either of these sizes, and placed in a temperature of 65° or 70°, and fully in the light under glass, they will begin to fruit almost at once, and ripe fruit will be gathered from them before winter can be said to be over.—A KITCHEN GARDENER.



TO OUR READERS.—We desire to acknowledge the receipt of many expressions of good will received during the week, with strong wishes for the continued prosperity of this Journal. We reciprocate the kind sentiments expressed towards us, and shall endeavour to present the Journal in a form that will fulfil the wishes of our friends and supporters.

— ROYAL HORTICULTURAL SOCIETY.—A special general meeting of the Fellows will be held at twelve o'clock noon on Tuesday, January 10th, in the conservatory, South Kensington, S.W., to confirm the resolutions passed at the meeting held on December 13th.

— THE following are the dates of the meetings of the ROYAL HORTICULTURAL SOCIETY'S COUNCIL, AND OF THE SCIENTIFIC, FRUIT, AND FLORAL COMMITTEES IN 1888. All are to be held on Tuesdays:— Council meetings—January 10th, February 14th, March 13th, March 27th, April 10th, April 24th, May 8th, May 22nd, June 12th, June 26th, July 10th, July 24th, October 9th, November 13th, December 11th. Scientific Committee—January 10th, February 14th, March 13th and 27th, April 10th and 24th, May 8th and 22nd, June 12th and 26th, July 10th and 24th, November 13th, December 11th. Fruit and Floral Committees—January 10th, February 14th, March 13th, March 27th, April 10th, April 24th, May 8th, May 22nd, June 12th, June 26th, July 10th, July 24th, August 14th, August 28th, September 11th, September 25th, October 9th, October 23rd, November 13th, December 11th.

— A CORRESPONDENT writes respecting the WEATHER in the north as follows:—"We have had in South Perthshire no wind, rain, or snow during the past week, but the weather has been as inconstant as during the preceding one, frost and thaw alternating every twenty-four hours. On the night of the 21st we had 13° of frost, and 7° on the night of the 24th. Roads are very badly covered with ice. Christmas Eve and Christmas Day were fine throughout." In the neighbourhood of London sharp frosts occurred on Sunday night, Monday, and Tuesday, ranging from 9° to 14°, the weather clear with little wind. At Dover and other places on the south coast there has been a heavy fall of snow, 2 or 3 feet deep; but on Wednesday morning in London the ground was only just whitened, the temperature being much higher than on the two preceding days.

— CHISWICK GARDENERS' MUTUAL IMPROVEMENT ASSOCIATION.—On January 25th, 1888, Mr. Lewis Castle, (*Journal of Horticulture*) will deliver an address entitled "A Gossip on Orchids," and on February 1st Mr. George Gordon (*Gardeners' Magazine*) will discourse on "The Uses of Flowers in Religious Services."

— WE omitted to state in a previous issue that Messrs. Alexander Shanks & Son, Engineers and Lawn Mower manufacturers, of Dens Iron Works, Arbroath, have changed their London office address from 27, Leadenhall Street to 110, Cannon Street, E.C. Their warehouse and show room will be at 44, Tenter Street East, Goodman's Fields, E.

— THE December number of the *Botanical Magazine* completes the forty-third volume of the present series, and is dedicated by Sir Joseph D. Hooker to Sir John Kirk in recognition of the services he has rendered to science by extending our knowledge of the Natural History (especially the Botany) and the Geography of Eastern Tropical Africa, and to mankind by the development of new industries (such as the india-rubber trade) in that country." The plates included in that number represent the following:—T. 6968, ANTHURIUM VEITCHI, a handsome Aroid, now well known in gardens, and apparently the reason it is figured is because the plant flowered at Kew this year. It has been in cultivation for eleven or twelve years, and was discovered in Columbia by Mr. Waters when collecting for Messrs. Veitch & Sons. There are now many fine specimens in collections of stove plants, but probably the largest is that in the possession of Baron Schröder at The Dell, Egham, of which an illustration appeared in this Journal, page 357, May 5th, 1887.

— IN t. 6969 is depicted another Aroid, HELICOPHYLLUM ALBERTI, a native of Eastern Bokhara, where it seems to have been found by Dr. Albert Regel, who despatched it to St. Petersburg, and tubers were sent thence to Kew in 1884. The spathe is large, of a deep maroon purple on the inner surface, and green on the outer. It is hardy in this country, but possesses a fetid odour that is not likely to gain the plant many admirers.

— T. 6970 represents an old but pretty plant, RUBUS ARCTICUS, which was first described in 1791, and now possesses no less than a dozen names. It is a native of the Himalayas, Burma, Java, China, and Japan, though it has also been supposed, without sufficient evidence, to be indigenous at the Cape of Good Hope and St. Helena. The leaves are pinnate, sharply cut at the margin, and silvery on the lower surface;

the flowers are large and pure white; the fruits, which are freely produced, are very ornamental, like long Raspberries, but insipid, though they are sold in the West Indian markets under the name of "Fram-boisier."

— IN t. 6971 is given a figure of *ONCIDIUM MICROPOGON*, a species supposed to be from St. Catherine's in South Brazil. It has long pendulous racemes of yellow flowers, the sepals narrow and barred transversely with brown, the lip very distinctly divided into three small roundish and stalked lobes. T. 6972 is of *Rhododendron rhombrium*, a Japanese species from the Island of Nippon, where it is found in mountain forests. It has neat rose-coloured flowers with even elliptical petals.

— A PENNSYLVANIAN firm has a new Tomato which is called PEACH TOMATO, the fruit of which it is said might be as easily mistaken for Peaches. It is said to be very productive, as also is the Puritan, the name of the newest Tomato from Boston.

— THE PHYLLOXERA has at length become nearly as bad on the roots of the Grape Vines in California as in Europe. In some localities the plantations are nearly ruined. They are, however, doing as the wide awake vineyardists of France are doing, grafting on the American stock. The varieties of the species *Vitis riparia* are found to be the best. The insect attacks these Vine roots as well as the roots of the European, but on account of the very fibrous rooting character, they do not suffer much. The young roots grow faster than the troublesome little insect can follow them. Hence these species of the Grape are known as resistant Grapes. Julius Dressel of Sonoma, in California, has 70 acres grafted on many varieties of the *riparia* section that are thriving wonderfully, and grafted Grapes will soon be a leading industry in California.

— A CORRESPONDENT sends the following note:—"THE FIRST LIVING TEA PLANT IN EUROPE.—Osbeck's voyage to China in the Swedish ship 'Gothic Lion,' which sailed in 1750, says: 'After a stay of four months and ten days in China, our ship and the other Swedish ship began their voyage home. Every one leaped for joy, and my Tea shrub, which stood in a pot, fell upon the deck during the firing of the cannons and was thrown overboard without my knowledge, after I had nursed it and taken care of it a long while on board the ship. Thus I saw my hopes blasted of bringing a growing Tea plant to my countrymen; a pleasure no one has been able as yet to feel, notwithstanding all possible care and expense.' In a footnote to the English translation, the translator, Forster, says: 'Linnaeus has had since 3rd of October, 1763, a fine Tea shrub brought him from China by Captain Carl Gustav Ekeberg, which is, as far as we know, the only one in Europe.'"

— CELERY AT KALAMAZOO IN MICHIGAN.—Mr. John van Bochove communicates the following to the "American Gardeners' Monthly"—"I saw a note about Kalamazoo Celery, saying it would be interesting to know the cost of land per acre, &c. I thought I would give you a few notes. It is estimated that two thousand acres are under cultivation, from nearly all which two crops are taken, and occasionally three crops in one season. Eighteen hundred persons, including men and the members of their families, are engaged in the cultivation of this vegetable; and thirty-five hundred people who get their living either directly or indirectly from Celery. Twenty and thirty and not infrequently fifty tons are shipped daily during the shipping season, which commences July 1st and continues until the Celery is all disposed of, which is usually before January 1st. The lumber for the boxes used in packing the vegetable alone cost 20,000 dollars last season. Land which formerly would have been considered dear at 30 dollars per acre, is now held at from 2 to 800 dollars per acre, according to location. The demand is excellent this season. The growers will commence to reap the first of next week and have most of it in by November 1st, when we may expect cold weather. The price is fair this season, the grower receiving 15 cents per dozen stalks. The amount of Celery shipped from here this season will crowd one-half million dollars pretty close. The crop is very fine notwithstanding the severe drought we have had all summer."

— THE same periodical thus speaks of a well known British horticulturist, MR. JOHN LAING.—"This is one of those intelligent British gardeners of whom the Old World is proud. In his early years he became eminent in botanical as well as horticultural pursuits; he has

since been a member of several prominent nursery firms—but is best known as a hybridiser of flowers. Many of the wonderful races of plants that adorn our gardens and greenhouses had their origin with him. The Tuberous Begonia had an early start from his hand. He was born near Brechin, in Scotland, in 1823."

— WE are informed that Mr. David Thomson, of Drumlanrig Gardens, has discovered a complete remedy for the GUMMING OF CUCUMBERS AND MELONS, an affection which causes trouble to a great number of cultivators yearly, and which seriously injures or ruins their plants and crops. The remedy, we are told, can be used as a preventive of gumming, or as a cure when the evil occurs. A specific of this kind is a requisite in gardens.

— GLASGOW AND WEST OF SCOTLAND HORTICULTURAL SOCIETY.—The Directors of the Glasgow and West of Scotland Horticultural Society announce that it is intended to hold three grand flower Shows during 1888. The spring Show will be held within the City Hall, Glasgow, while the summer and autumn Shows are to be held in connection with, and under the auspices of the Glasgow International Exhibition of Industry, Science, and Arts. The dates of the Shows will be as follows:—Spring Show in City Hall, Glasgow, Wednesday, 28th March; summer Show in International Exhibition, Kelvingrove Park, on Wednesday, 11th, and Thursday, 12th July; autumn Show in the International Exhibition on Wednesday, 12th, Thursday, 13th, and Friday, 14th September. The Secretary is Mr. Franc. Gibb Dougall, 167, Canning Street, Glasgow, and the Treasurer Mr. Chas. Maedonald Williamson, 194, West George Street, Glasgow. The schedule of classes and prizes for the spring Show is just to hand, and includes provision for forced plants, bulbs, alpine plants, &c. The prizes, however, are not large, ranging from 30s. to 2s. 6d.

— AURICULA PAGE'S CHAMPION.—Mr. J. F. Kew, London Road, Southend, writes: "Although not a fortunate possessor of this much-coveted variety, I am inclined to think your correspondent, Mr. Kilgour, page 540, has the true sort. In 'Tyas's Popular Flowers,' published in 1843, it is figured with a deep plum-purple body colour, shaded with a decided dash of red, and can certainly not be described as velvety black. This agrees with my recollection of the flower as shown so many times in London by Mr. Horner. Of late years, however, it has not been seen so often. In the same publication are mentioned two other of Page's flowers—Duchess of Oldenburg and Lord Hill. It would be interesting to know if either of these are still in existence. Although said to be a London-raised flower, Champion seems now to have completely disappeared from the south."

— MESSRS. WOOD & SONS send us a list of about forty prize-winners of their several cups and medals offered for competition during the past season, with an intimation that the lists are free to all applicants.

— CHRISTMAS IN CANADA.—The *Liverpool Journal of Commerce*, December 21st, 1887, has the following note:—"The dominion of Canada, more especially the new province of Manitoba, is largely peopled by natives of the British Isles, and these are strongly attached to the traditions of the mother country, its institutions, and its observances. In the last steamer which left the Mersey for Halifax upwards of 100 tons of space was occupied by crates of Holly and Mistletoe, principally on through bills of lading to Winnipeg, Manitoba."

— THE CAMELLIA.—At the last meeting of the Wakefield Paxton Society at the "Saw Hotel," Mr. H. Oxley presided, Mr. W. Glover was in the vice-chair, and there was about an average attendance of the members. Mr. W. L. Skinner of the Silcoates Nurseries was announced as the essayist, and in introducing him to give an address on "The Camellia," Mr. Oxley spoke of him as one of the fathers of the Paxton Society, and one of the oldest gardeners in this district. He said Mr. Skinner always gave them some interesting information, and he combined Scotch humour with English wit. Mr. Skinner, who has been in the district twenty-four years, then gave the Paxtonians some good advice with regard to the growth of the Camellia. In the course of his remarks Mr. Skinner said that although the Camellia has lately given way to the growing popular taste for Chrysanthemums, he believed the Camellia will never go out of favour; in his opinion it still stands in the front rank of flowers for winter. He explained that though the Camellia is a native of Japan and China, and said it is far easier to grow

in this country than is generally supposed, indeed it is often killed by kindness in many parts of England. In the south of England and west coast of Scotland the Camellia is grown out of doors, and in other parts of the country it thrives where the protection is a simple glass cover. He fully explained the mode of growing the Camellia from the seed to the flowering period, and showed that great patience and perseverance are required for about six years before plants which will sell for 1s. each can be obtained from seed. The process of grafting and treating the plants was minutely described, and Mr. Skinner particularly urged his hearers to guard against sudden transitions of heat and cold, or the flower buds will fall from their plants. If they studied Nature as much as possible their efforts in the growth of the Camellia would be attended with pleasure and success. An interesting discussion took place in which Messrs. Brown and Garnett were the principal speakers. On the motion of Mr. W. Glover, seconded by Mr. T. Garnett, and supported by Mr. Amos Sexton, Mr. H. S. Goodyear, and Mr. Oxley, a very hearty vote of thanks was given to Mr. Skinner for his interesting address.

### MICROSPERMA BARTONIOIDES.

THIS pretty annual now figured is closely allied to the Bartonias, from its resemblance to which it has derived its specific name. It is a native of Mexico, and was introduced into this country from Hamburg

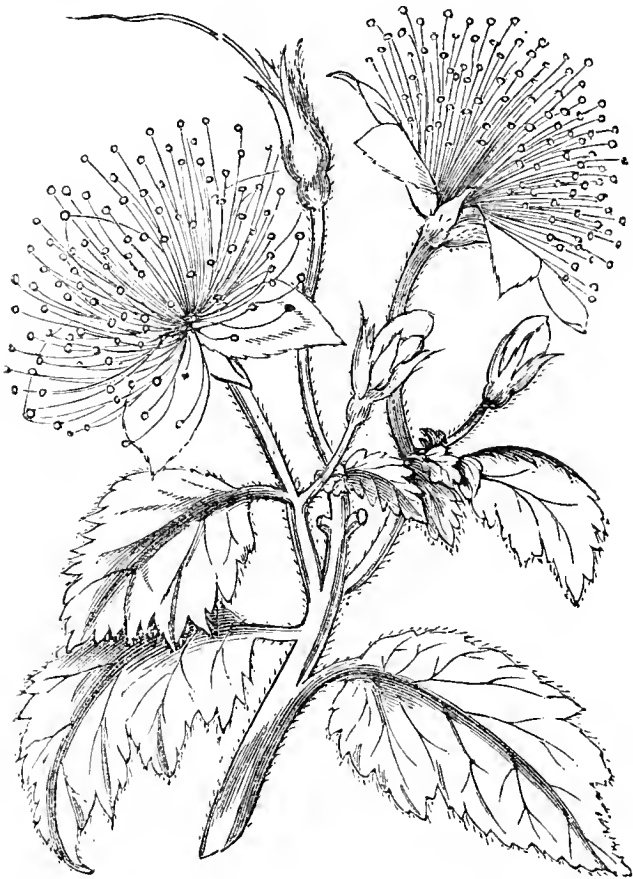

Fig. 65.—*Microsperma bartonioides*.

in 1849, under the name of *Eucnide bartonioides*. It is of succulent habit, growing a foot high, with ovate, lobed, and serrated foliage. The flowers, which are nearly 2 inches across, are terminal, and produced either singly or in pairs, with five spreading, ovate, obscurely toothed petals, of a sulphur-yellow above, but much paler beneath. The stamens are arranged in five fascicles or bundles, the filaments of each fascicle being united at the base, and attached to one of the petals.

The cultivation of the *Microsperma* involves a little care; for, although it is quite hardy enough to bear the open air, its succulent nature renders it liable to injury in all stages of its growth from any excess of moisture, whether in the seed-pans or the borders. It may be raised in the spring on a gentle heat, in pots of well-drained sandy loam. The seeds should be thinly sprinkled on the surface of the soil, and then gently pressed in; they will germinate with greater readiness than if covered more deeply. In raising these and other small seeds, it is a good plan to cover the rim of the pot with a piece of glass, which will greatly retard the evaporation from the soil, and obviate the necessity of frequent watering; but as soon as the seedlings are above the soil, the glass should be partially removed, as too much care cannot be taken to preserve them from damping-off. When sufficiently large to transplant, they should be potted two or three together in 4-inch pots, using a mixture of sandy loam and leaf mould or peat; good drainage must be insured by a handful of crocks. In May the plants may be transferred to the borders, with their balls of earth entire. We are

inclined to think that the seed might be sown in the open borders about the middle of April, if the soil is light, and a handlight can be placed over the patch for the first month or so. The plant may also be grown in pots for the window or greenhouse; and in this situation it will be more likely to ripen seed than in the open ground. As in the case of the *Loasas* and some other genera of the same family, the foliage of this plant is armed with stinging hairs, but they are much less venomous than in *Loasa* and *Caiophora*, and need not deter the amateur from its cultivation.—W. T. S.



### DENDROBIUMS.

BEFORE Orchids generally were so largely cultivated the good old *D. nobile* was to be seen in many collections of plants, and it is yet one of the most serviceable of the genera. It well repays for good culture, and where many buttonhole bouquets are required during the winter and spring months it is invaluable. Some of the best specimens of it are frequently to be seen in an ordinary mixed plant stove, and it is in such a position where ours are grown and flowered. With these, as with many other Orchids, it takes some time to find out the positions best suited to each, but when once found, their culture becomes a comparatively easy matter. Ours are most at home on the front wall of a central pit filled principally with *Crotons*, *Ixoras*, and *Dracenas*. Here they get plenty of heat and moisture and light, the blinds being let down only when bright sunshine prevails. A successful Orchid-growing friend of mine is of opinion that the principal object in all cases should be to fill the pots, pans, or baskets with roots as quickly as possible, and plenty of bloom is sure to follow. If not exactly correct in all instances, it is a very important factor in all successes with *Dendrobium nobile*. When they are either pulled to pieces and repotted more often than is wise or expedient; or, on the other hand, are not attended to often enough, very few active roots are found in the compost, though there may be plenty on the plant—such unhealthy plants usually forming young growths where flowers ought to be produced. It was with a quantity of these young shoots that we made a serious commencement of *D. nobile*, and a few details from this stage may be instructive.

Early in the spring is the best time to take off and establish these already rooted growths, and only those that are firm, and say about 5 inches or rather more, be selected. Any that are soft should be left for a few days longer, or otherwise they are liable to decay. We prefer to have them with a short piece of old pseudobulb or growth attached, but if this cannot be spared, the young growths may be cut cleanly away. The next proceeding is to half fill as many clean 5-inch pots as are needed with crocks, on this placing a layer of the roughest of the compost, the latter consisting of roughly broken Orchid peat, crocks, charcoal, and chopped sphagnum in about equal quantities. About four growths are placed in each pot, and well raised above the rim, the compost being carefully disposed about the roots, without, however, burying the collar. A tiny stake is given to each growth, but no sphagnum is packed over the surface of the pots, this oftentimes doing more harm than good. Very little water must be given at the outset, sprinkling the growth being all that is necessary for a time, and no shade whatever ought to be given. When it is found both the top and roots are active water may be given—they must be treated, in fact, much the same as ordinary newly potted stove plants. If kept growing in a brisk heat, these newly established growths will, in one season, attain a length of from 12 to 15 inches in length, and proportionately sturdy. In the autumn they should be given a position as near the glass as possible, and very much less water at the roots, only enough being applied to keep them from shrivelling. The temperature of our house during November and December rarely exceeds 60° by night, and from 5° to 10° higher in the daytime, this being a comparative rest for the majority of the occupants of the house. A higher temperature and much moisture in the atmosphere, such as is maintained in very many stoves, would not favour a rest, and in all such cases the *D. nobile* will be better for a time, or say from October to January in an intermediate temperature, or even a greenhouse, little or no water being given during that time. When given a higher temperature, many of the growths flower freely early in the spring, in which case they may be cut to their full length, or be cut down directly after flowering is over. Should they not flower it is advisable to preserve them, as they most probably will do so the following spring. During the



second year no repotting ought to be attempted, unless in the case of any badly furnished, but all should be encouraged to push up fresh growths from the base of the old ones. During the growing season abundance of water should be given them, and plenty of heat and overhead moisture, the autumn resting being again resorted to.

As will have been gathered from the preceding, we believe in pruning *D. nobile*, as it is very certain since we have adopted the practice ours have greatly improved. It is the only sure way of securing even handsome heads of bloom, this being well set off by the fresh green foliage, and altogether more attractive in appearance than when the flowers are produced on the naked two-year-old growths. At the present time we have a row of healthy plants, the growths of which promise to flower at nearly every joint. Directly after they have flowered all will be cut down to near the swollen bases, and in a few days strong fresh growths will follow. If the plants are getting too large for their pots, a shift is given, as much of the old compost being picked away from the roots as possible without greatly damaging them, prior to being distributed through the fresh compost. Any not doing well are frequently improved by being shaken out of the sour compost, having the dead roots cut away, and then be repotted in a fresh mixture. Plants not repotted—and as before stated there is no necessity or wisdom in making this an annual proceeding—may well have a surfacing of fresh compost, this being much preferable to an unavoidable mutilation of the roots. Sphagnum we still dispense with as a surfacing, the plants doing as well, or better, without it. If a long succession of bloom is desired, batches of plants may be rested and re-introduced into heat at intervals of about three weeks or a month, the aim being to get them into flower early, or say at the present time, rather than to unduly retard flowering till late in the spring, and thereby lessen the chances of well ripening the late-formed growth.

*D. nobile* is frequently described as a greenhouse plant, but it is altogether a misleading description, at all events I never saw any presentable pots of it wholly grown in a greenhouse. They require the brisk heat and moist atmosphere of a stove, forcinginery, or forcing pit to cause them to form a long stout growth, then comes a spell in a greenhouse, followed by a return to heat to properly open the flowers. There are several forms of *D. nobile* commonly cultivated, some being more brightly coloured than others, but the *D. nobile nobilium* is by far the best, and is yet very rare indeed. An occasional possession of a single flower of it is all I can aspire to. The growths of this and other choice *Dendrobes* may be increased either by cutting into short lengths much as we would old *Dracæna* stems, or the growths may be coiled round on the surface of a pot of Orchid compost and pegged down, nearly every joint eventually producing a growth which may be taken off with strong roots attached when fairly firm.

*D. Bensoniæ*, which usually flowers in May, is a very beautiful deciduous species, requiring much the same treatment as *D. nobile*. It succeeds admirably suspended in pans, and the growths being well ripened flower at nearly every joint. *D. Falconeri* I am anxious to succeed with, as it is a gem among even the beautiful and large family of *Dendrobes*. The growths or pseudo-bulbs are very small, knotty, and branching, but when kept in a comparatively small pan suspended near the glass in a plant stove many fine beautifully coloured flowers are sometimes produced from both old and young growths. It flowers in May and June. It is evergreen, but does not need much water during the late autumn and winter months. *D. Dearei*, a comparatively but little known species, is worthy of a place in every collection, especially seeing that a mixed plant stove exactly suits it all the year round. It forms erect growths, which retain their leaves for a long time, and, what is a rather unusual occurrence, each growth is capable of flowering several times. Our plant gave us two spikes in June, and it is again beautifully in flower, this being a characteristic of the species. The flowers with us are of medium size and pure white, with the exception of a greenish stain on the lip, and they remain fresh fully two months. Altogether it is a remarkable introduction, which can be bought at a fairly cheap rate, and when extra well grown produces flowers larger than *D. nobile*. Mr. Cypher strongly advised me never to dry it off or rest it in any way, this being the cause of many failures. It succeeds in an ordinary well drained pot, and a compost similar to that given to the *D. nobile*. If found to be dry at any time it is treated to a dip in the tank of warm water kept in the house. *D. formosum giganteum* is, as far as my experience goes, the finest of all *Dendrobes*. It is of sturdy erect growth and evergreen—that is to say, does not shed its leaves the same season as formed. The flower spikes are produced from the point of every strong growth, and usually in August or September. The individual flowers with us are usually about 4 inches across, but I have seen them still larger; sepals and petals pure white, the lip also white with a yellow blotch near the throat.

These again last a long time; our best spike we kept six weeks, and was then quite fresh when cut. I prefer to keep both this and *D. Dearei* in the house where grown, being under the impression a cool house suits neither the bloom or plant. It succeeds admirably on a square of wood without any compost, or in a pot or basket of the rough porous compost previously described. It is a vigorous grower, requiring plenty of light and moisture, one successful grower giving his plants, when growing strongly, a little weak liquid manure. *D. bigibbum* is the latest to flower, and completes my limited selection. It is a very beautiful species, and very unlike the rest of the family. Mr. Cypher has a remarkably fine batch of it at the present time, worth going a long way to see, and I cannot do better than give his treatment. The plants are all kept in comparatively shallow pots or pans, these being well drained, and a compost consisting largely of good peat and sphagnum is used. All are suspended near the glass in a brisk temperature, plenty of water being given the plants at the roots, and a moist atmosphere maintained. Thus treated they form unusually strong growths, the best being nearly 3 feet in length and proportionately strong. Rather less water is given in the autumn, but they are never wholly dried off or rested in a cool house. The flower spikes are produced from the points of the young growths, and also from the old bulbs, these continuing to flower for several seasons in succession. There are several forms of this, as of so many species, the best having extra rich rosy purple flowers, but all are beautiful and acceptable at this time of year. A plant we grew near the thick rolled glass of a warm fernery is flowering from the old stems only, and this position will not again be tried. We also have plants of *D. thysiflorum*, which annually flower freely without any trouble being taken with them. The pendulous spikes of yellow flowers are very beautiful, but retain their freshness for a very short time only, and for this reason do not recommend it.—W. IGGULDEN.

#### LÆLIA ANCEPS.

A GRAND specimen of the above may now be seen in the gardens at Clevely, near Liverpool, T. S. Timmis, Esq., carrying sixty spikes, with 140 fully expanded blooms of large size and good depth of colour. Mr. Cromwell, the able and enthusiastic gardener, informed me the plant was imported two years ago, and is believed to be identical with a variety known as *L. a. grandiflora*. I am also favoured with a bloom, which I enclose for your inspection. This is by far the largest number of spikes I have ever seen on this beautiful autumn-flowering *Lælia*, and as far as I know, the largest number that has been produced at any time. The plant is in robust health, grown on a raft suspended in the usual manner. It is, however, not the only plant worthy of special note. A bank of *Calanthes Veitchi* and *vestita* arranged with Ferns, Poinsettias, &c., are particularly good. Orchids, generally, are in splendid health, the collection of which, already rich, promises to become one of the best in the north of England.—BRADWEN.

[The variety is a good one, the flower sent measuring 5 inches from tip to tip of the sepals, and 4½ inches between the extremities of the petals.]

#### EXHIBITING AND JUDGING BOUQUETS.

"A LEARNER" is rather inconsistent in some of his remarks. In his first letter he strongly condemned the practice of inserting Fern fronds when the bouquets are ready for exhibiting. It has since been pointed out that the most straightforward course he could have adopted would have been to show his own bouquets, properly made, and then to have protested against the others not in accordance with his ideas. He now excuses himself by saying it is such a small matter that it would be disregarded by the judges. If that is so, why did he write in such strong terms respecting it? I hope "Learner" is not a disappointed exhibitor; for I am sure he could tell us much that is useful, but not by condemning the practices of other exhibitors and then following them himself.

By the way, I consider that he is unduly severe with Mr. Chard's exhibit; and I doubt if he will ever equal that exhibitor in the tastefulness of his floral displays or in the number of his successes. I have seen many contributions from Mr. Chard and his wife that for simplicity of materials and grace in combination could scarcely be surpassed; and I am certain that during his career as an exhibitor he has assisted greatly in the improvement of taste in these matters. That their merits have been widely appreciated is amply proved by Mr. Chard's list of prizes won during the past three years—namely, ninety first prizes at Crystal Palace, Brighton, Croydon, Richmond, Tunbridge Wells, Newcastle-on-Tyne, Southampton, Regent's Park, Nottingham, Chiswick, Salisbury, Taunton, Matlock Bath, Exeter, and Hastings. These were awarded for bouquets, stands of flowers, baskets, table decoration, buttonholes, &c.; and if "Learner" can produce a list like that he may safely pose as a critic in floral decorations. I only know one firm that can equal it—namely, Messrs. Perkins & Son, of Coventry.—AMATEUR FLORIST.

## A WINTER'S DAY AT CHELSEA.

THOSE who are familiar with Messrs. J. Veitch & Sons' great nursery in the King's Road, Chelsea, know quite well the wonderful resources of the establishment and the enormous stock of plants it contains from every quarter of the globe. With so wide a diversity of plants from many climates a perpetual succession of attractions is ensured in all seasons. It requires a number of visits to enable a stranger to thoroughly realise this fact, but it is of little consequence what period is chosen for the inspection, there is always ample to interest a visitor. Of course at certain times some special feature largely predominates, as the Amaryllises, the Carnations, the Chrysanthemums, and the Orchids, though the flowering period of the last named is much more extended than the others. Still, of all times the end of December would be considered likely to be the least satisfactory for a journey to the Chelsea nursery, yet how erroneous an opinion that would be may be gathered from the following notes on a visit made a few days ago.

## GREENHOUSE HYBRID RHODODENDRONS.

To this firm belongs the credit of having produced a group of handsome flowering plants, the merits of which are now fully recognised in hundreds of gardens, and their popularity is increasing yearly. The greenhouse hybrid Rhododendrons, as they are rather indefinitely designated, comprise the now numerous descendants from *R. javanicum* and *R. jasminiflorum*, which, crossed with other species, have resulted in the production of a series of distinct forms, remarkable for the substance and rich colours of their flowers, both single and double. They possess several valuable qualities, and not the least of these is the duration of the flowers, which individually retain their beauty for several weeks; the rich colours also are quite exceptional, combined with wax-like substance and gloss. The somewhat tall or straggling habit of the earliest hybrids was not in their favour, but recognising this defect the efforts of the hybridisers have been steadily directed to its rectification, and this has been to a great extent accomplished. The plants are now much more compact and bushy in habit than formerly, and it is particularly noticeable in the double varieties. Another good point in their favour is that they are easily grown, though some have fancied otherwise from the neglect of a few simple items in their culture. They succeed admirably in good turfy peat and sand with moderate but carefully arranged drainage, without any manure in the soil or liquid manure at any time. They should be potted firmly, but not rammed hard, have ample root room, plenty of water, a humid atmosphere, and a minimum night temperature in winter of 50°. Frequent syringing is requisite to encourage growth and keep them clean, and if this is well attended less watering at the roots will be needed. In repotting the plants treat them liberally for space—that is, a strong young well rooted plant in a small thumb pot may be transferred into a large forty-eight quite safely, and indeed beneficially. This operation can also be performed at any time, though the bulk of the stock may be preferably so treated in spring or autumn. They are readily increased by cuttings inserted singly in small pots, and if flower bud shoots are taken they will flower in two or three months' time; for example, there is a plant of Princess Alexandra 4 inches high in a small thumb pot, bearing a truss of nine fine flowers. These make quite as good plants subsequently, as after the flowers are off several shoots start from the same point, and a more branching plant is thus obtained. If the ordinary growing shoots are used as cuttings it is often necessary to cut them back to induce buds to start lower on the stems, as if not well furnished from the base they never make good specimens.

Some idea can be formed of the usefulness of these Rhododendrons for winter flowering when it is stated that there are now eighteen named varieties or hybrids in flower, besides several novelties that have not yet been named, and over 150 trusses are expanded, comprising about 1000 flowers. In the show devoted to these plants the following are now in flower:—*Balsaminæflorum album* with eight trusses of seven flowers each, forming a good compact specimen with its double flowers full and of excellent form; Princess Alexandra of a delicate tint, free and beautiful; Taylori, one of the original forms but still excellent in many points, the flowers large with broad lobes, of a fine rosy hue, and in good trusses; Duchess of Teck, rich and handsome; Duchess of Edinburgh, flowers very massive, of a rich dark red colour; *Javanicum*, large orange flowers; Maiden's Blush, delicate pale pink or blush; Favourite, bright pink, light tube; Princess Frederica, yellowish buff, flower of great size, showy; Prince Leopold, orange red and buff, good flower, free; *Jasminiflorum*, white comparatively small flower in good trusses, and very freely branched, it is one of the parents of the series of hybrids and crosses; Princess Royal, a fine pure pink, a favourite form, and almost constantly flowering; Crown Princess of Germany, salmon red, yellow tube; Queen Victoria, orange buff, the flower stalks deep red; Duke of Edinburgh, deep rosy crimson, good trusses, free; and Duchess of Connaught, rich dark red, handsome flowers. In the house reserved for novelties, several of great promise are in flower, but have not received names; yet others that have been honoured with titles and have been certificated are as follows—*Jasminiflorum carminatum*, exactly of the *Jasminiflorum* type, but with the flowers bright rose coloured, very free, a small plant having six trusses; Excelsior, yellowish buff, with red stamens, large flower and truss, ten flowers in one on the plant under notice; and Monarch, rosy salmon, round even lobes, ten flowers on a truss. Several others have been obtained, constituting a distinct group with shorter tubes, and more bell-shaped flowers, combining with these characters a dwarf compact habit.

## ORCHIDS.

To enumerate the Orchids in flower at Chelsea would at any period of the year require a long chapter to do them justice, and even in December if all the plants in flower in the numerous houses could be arranged together in one large structure an astonishing and highly effective display would be produced. But the principal object is to provide the exact requirements of the plants, and this cannot be effected by frequently transferring them from house to house, and a check at this time of year to delicate Orchids often results in irreparable injury. Many excellent cultural lessons can be learned at Chelsea, and one of the most interesting of these is the successful manner in which Orchids are grown in small pots, pans, or baskets. This subject has been referred to before, and there is no doubt that amateur cultivators often err in giving their plants too much root room. Some of the most successful have fully recognised this fact, and all except the stronger of the terrestrial Orchids are much more restricted in their root space than formerly. There is no danger of excess of root space in the case of Orchids on blocks, but even with them a much neater effect is produced by the employment of moderate sized pieces of wood. An example of this is afforded in the case of that useful, beautiful, and fragrant Orchid, *Cattleya citrina*, of which an illustration is given in fig. 66, representing one of Messrs. Veitch's plants sketched some time since. This species thrives admirably at Chelsea, and when the plants suspended from the roof of one side of a long range are in flower they have an extraordinary appearance.

In the second part of the admirable publication the "Manual of Orchidaceous Plants," devoted to *Cattleyas* and *Lælias*, published by this firm, there is a most interesting account of the history and culture of *Cattleya citrina*, which is here reproduced.

"One of the most remarkable of *Cattleyas*, and the only one found within the Mexican territory proper, where it is abundantly distributed over the mountain ranges and high table-lands lying between the 17th and 20th parallel of north latitude at elevations ranging from 6000 to 7500 feet. Its peculiar inverted habit and handsome fragrant flowers early attracted the attention of naturalists, among the first of whom to make mention of it was the Jesuit Hernandez, who wrote on the Natural History of Mexican animals and plants in the seventeenth century, and who described this plant under the almost unpronounceable name of *Corticoatzontecoxochitl*, a name by which it appears to have been known at that period among the natives of the country, by whom the flowers were held in high esteem. It was first introduced into England by the Horticultural Society of London, about the year 1823 or 24. The Society, however, possessed but a single plant of it, which appears to have died a short time after its introduction. We find no further mention of it till 1838, when it was introduced from Oaxaca to the Duke of Bedford's collection at Woburn, where it flowered in April of the following year, nor again till Ghiesbreght, twenty years later, collected a considerable quantity on the slopes of the mountains of Michoacan for M. Linden's horticultural establishment at Brussels, whence it became generally distributed among the Orchid collections of Europe. From that time to the present, frequent importations have caused it to become a familiar object in almost every Orchid collection in the country. The flowering season of *C. citrina* is in April and May. The specific name refers to the colour of the flower, which, when held in an erect position, has some resemblance to that of our native plant *Tulipa sylvestris*.

"Cultural Note.—*C. citrina* has always been considered a refractory plant under cultivation, a circumstance that has arisen probably more from inattention to the climatic conditions under which it lives in its native country, than from any cause inherent in the plant itself. Growing in the "Tierra fria," or cool region of Mexico, where the atmosphere is comparatively dry for nearly six months of the year (November-April), and the rainfall during the remainder of the year not excessive for tropical latitudes, it follows that a cultural treatment as consonant with these conditions as the altered circumstances of a glass structure will admit, should be applied. The late Mr. J. C. Spyers once remarked 'that few can boast of growing and flowering *C. citrina* well for half-a-dozen years together,' and, therefore, it should be tried in various ways. When blocks of wood are used, which the inverted habit of the plant would seem to suggest as the most suitable medium for it, the plants should be securely fastened with wire, and the blocks suspended with the leaves downwards; they will succeed for a few years on the wood of almost any of our commoner trees, as the Apple, Hawthorn, Birch, and Box, as well as Teak, over which the roots will creep freely. The blocks should be suspended in the coolest part of the *Cattleya* house, where they can receive the maximum of light and air. There is scarcely an Orchid known that, for six months of the year, requires a more moderate supply of water than *C. citrina*; but when developing its growths, and the flower scapes appear, it should be liberally supplied. We have, during the past few years, successfully established imported plants in small shallow pans with good drainage, surfaced with sphagnum and peat, and suspended from the roof. The new growths have been most satisfactory, and have produced flowers as fine as we have ever seen; but even here Nature vigorously asserts her right: the imported bulbs with their leaves are placed in the pan in an erect position, the new growths with their leaves take a horizontal one, while the subsequent growths assume their natural downward direction outside the pan."

Cypripediums constitute an important feature at this time of year, and it will only be necessary to mention a few of the principal to give an idea of their diversity. Most noticeable is *C. Leeceum superbum*, the celebrated hybrid from *C. Spicerianum* and *C. insigne*, which preserves all the good qualities of hardness and vigorous constitution of the latter parent, with a bold broad dorsal sepal almost wholly white, except a few purple and brown spots and lines at the base, and a brown or yellowish polished lip. It endures the fogs of town districts much better than *C. Spicerianum*; indeed, it is practically unaffected by them, it is also very floriferous, for small plants in thumb pots have



three and four fine flowers each. This *Cypripedium* will undoubtedly obtain a great popularity, and in the future when it becomes more abundant will supersede all but the best varieties of *C. insigne* for winter culture. Of the *Sedeni* type we have the original form, *C.*

*vivicans*, a fine dark variety in the way of *C. cœnanthum superbum*, *C. insigne Maulci*, *C. microchilum*, *C. marmorophyllum*, *C. vexillarium*, *C. calosum*, *C. Barteti*, *C. purpuratum*, *C. Selimi*, and *C. Mrs. Charles Canham*. The last named resulted from a cross between *C. Veitehi* and



FIG. 66.—CATTLEYA CITRINA.

*Sedeni eandidulum*, with most delicately tinted or nearly white flowers and *C. cardinale*, which has a deep rose compact lip, bluish petals, and whitish dorsal sepal, a handsome and useful hybrid. *C. Schroedera* is also one of the rose or crimson tinted hybrids with massive flowers, a large lip, and very long drooping petals. Then there are plants of the rich dark polished *C. cœnanthum superbum*, *C. calurum*, *C. Harrisianum*

*C. villosum*, but did not originate in this nursery; it has very large flowers, 6 inches in diameter from tip to tip of the outstretched petals, the lip is also deep and of great size, the dorsal sepal and petals have a peculiar dark reddish brown tint, the lip is lighter coloured and well formed. It is extremely free, of strong habit, and evidently a thoroughly useful acquisition.



Amongst the miscellaneous Orchids the *Calanthes* rank next to the *Cypripediums* in number of flowering specimens at the close of the year, the excellent *C. Veitchi* with varieties of *C. vestita* afford a wealth of flowers in long graceful racemes, from white to the richest rose. The hybrid *C. lentiginosa* of the *C. porphyrea* type, and *C. bella* being choice additions to this group. In the cool house are many beautiful varieties of *Odontoglossums Alexandræ* and *Pescatorei*, one of the former in particular being very notable with a raceme of ten beautifully formed flowers, the sepals and petals broad, heavily suffused with a distinct purple tint, a few brown spots in the centre of the petals and lip. *Phalænopses*, *Saccolabiums*, *Oncidium*s, with *Angræcum sesquipedale* are the chief attraction in the warmer houses, and of the last named there are about seventy-five flowers opening, that will shortly afford some grand examples of this remarkable Orchid. Other plants in flower are the following:—*Sophranitis grandiflora*, *Odontoglossum maculatum*, *Andersonianum*, *Insleayi*, *leopardinum*, *Dendrobium endocharis*, *Angræcum bilobum*, *Dendrobium chlorops*, *Cymbidium Lowianum* *Mastersi* and *giganteum*, *Vanda cœrulea*, *Zygopetalum Mackayi*, *Lælius anceps*, *L. acuminata*, *L. anceps* in several varieties, including *Sanderianum*, and *Epidendrum ciliare*.

#### MISCELLANEOUS.

*Lapagerias*.—Though not in flower now, the house of white *Lapagerias* contains such a large stock of healthy young plants that it well deserves a note. For cool houses no climbers can surpass the *Lapagerias*, both red and white, but especially the latter. At Chelsea no fire heat is employed, except in very frosty weather. Keeping the plants cool and clean renders them hardy and healthy, and it is to neglect of these two points that most failures are attributable. Young plants from layers are in all stages, from those a few months old to specimens fit for training to the roof of a large conservatory or placing on trellises, and preparation has been made for next year's supply by filling a large bed with stems to yield shoots for young plants next season. With them are grown some plants of the interesting hybrid *Philageria Veitchi*, which, however, is not quite so floriferous as either the *Lapageria* or the *Phileria* (its parents): a curious fact, as many hybrids are more free than the parents. Perhaps, however, there may be some cultural secret that has yet to be discovered. It is also rather strange that, though the *Philageria* is of climbing habit, like the *Lapageria*, it cannot be propagated by layers, but only by cuttings.

The new and graceful Fern, *Nephrolepis rufescens tripinnatifida*, is represented by some capital specimens, which in the erect and plum-like character of the tall fronds is rather suggestive of the *Struthiopteris*. The blush-white *Kalanchoe carnea* is a free and useful plant, one specimen having twelve large trusses of its small, neat flowers. The race of winter-flowering *Begonias*, obtained from crosses between *B. socotrana* and the tuberous varieties, include a trio of beautiful forms—*John Heal*, *Adonis*, and *Winter Gem*—all very distinct, of good habit, with beautiful foliage and abundant, long-lasting flowers. The *Pitcher Plants* are in the best condition, and afford at the present time the finest display that could be found in cultivation of all the best species, varieties and hybrids. In addition, there are the usual winter-flowering *Heaths* and *forced plants*, which render the show-houses extremely g

#### THE DINNER AT ANDERTON'S.

(Continued from page 539.)

##### CHAPTER II.

As will be seen in this correct account of the celebrated dinner, I am working on the show system in dividing the classes and arranging the groups for effect. It will be noted also, as at most shows, there were "no entries," and these having been accounted for by my obliging friend, we will now take a glance at the collections staged. The big classes were arranged across the end of the room, President Sanderson occupying the "leading position," as the regular reporters say, with the high officials stretching along on each side of him; but one of them I noticed was flitting to and fro as if acting as aide de camp to the grand Panjandrum.

Before proceeding further let it be said that everything was conducted in the most "proper" manner at the commencement of the proceedings. It would not be right to allow the Christian world to think that as we had no clergyman we had no grace. This was said with due solemnity, and the vocalists sang with much feeling "For these and all thy mercies," the company rising and remaining standing till the last sweet cadences died away. Then the clatter began down the three long tables, and it was a clatter. Between the courses I had time to look round, and of course wanted to know a few things. I had been watching a guest taking soup, and his action denoted energy of character. I asked, "Who is that man with the beaming countenance and not many whiskers, he who keeps half rising and leaning across the table for a jaw with his *vis-a-vis*?" "Oh," said my guide, "that is Cannell." "Really, I have had lots of good things from him, but never saw him before. He looks very happy, and as if he were doing well; bought 10,000 acres of land in Kent, hasn't he? and hunts?" "No," you are wrong there," he replied; "he has got a lot of land, but not so much as that, and I have not heard that he hunts." "Well, of course I may be wrong, but I thought I had read about his favourite horse, 'Tom,' that I took to be a hunter." He may have been, but I guess all he does now in that line is hunting after business." I was glad to hear that, for I have known hunting farmers go too fast and fall into the pit of depression. An hour afterwards the

head of the Home of Flowers went bustling past me. I thought I heard him say he couldn't stop another minute, he couldn't indeed; it was a fine meeting, very fine—very fine, but he was obliged to go to meet the Duke of Somebody (I didn't catch his name) at his club about sending a shipload of things to the colonies. And that was the first and last I saw of Mr. Cannell. His table companion over the way was Mr. Wright. I had seen him before, but thought he had grown.

But the clatter is over, the clearing away is done, thanks returned, and the President, with up-raised hand, flourishing a mallet. He made his "pile" in the timber line my friend thought, and could afford a good mallet. Well, he had one and he used it. When calling attention it came down, making the table shake and the glasses jingle. When the cheering had been long enough it was up in the air in a threatening attitude. It acted like a talisman. I never saw such a magical mallet. Let it be said the great grower and finisher of incurved blooms is a shortish, big framed, square shouldered, sharp featured man, with a good deal of facial expression and well-marked lineaments. He is active, energetic, enthusiastic, full of good humour of a rollicking kind—the man for the occasion, apparently everybody's favourite, and perhaps there are not many like him at threescore years and ten—just the man to strike a stranger.—I don't mean with his mallet. "Gentlemen," he said, in robust tones, "we are all loyal here, I give you 'The Queen, the Prince of Wales, and all the Royal Family.' We are all loyal I say, loyal to the backbone. We revere them, we'll fight for them if wanted, and we'll win, the same as we do at the shows." Down came the mallet, crash went two or three hundred hands on the tables, with as many feet dancing on the floor, in came the singers to take the lead, and the "National Anthem" went with a swing. So did the mallet quickly after for the next toast from the Chairman, "The National Chrysanthemum Society." It was a noble institution, he was proud of it, proud to belong to it, proud of the men who made it. It had done wonders, and it would do more, for it had got the men and got the money—not (in subdued tones) that it would refuse more, and if any of the company pressed it into the coffers, he shouldn't like to be an obstructionist. (Cheers.)

"And now gentleman," he said almost solemnly, as if approaching something of tremendous moment, "I have the great pleasure, the very great pleasure, of asking Mr. Richard Dean to propose the next toast—"Our Patrons and Fellows." A rattling cheer greeted him as he rose—a tallish, thinnish, palish faced, and iron grey hairish sort of man. With slightly tremulous voice, yet clear, and in thoughtful words and fluent utterance he did his duty well. After conveying a tribute of appreciation to all supporters, and recognising the honoured presence of one who had served his country and won the great prize of the Star of India, he expressed the pleasure it was in these days to know that all ranks could meet so happily in a Society that was strictly non-political. This was a "hit, sir, a decided hit," and the mallet had to go up to stop the cheers. The speaker then paused to tell what he called a melancholy story, but I should spoil it in attempting a reproduction. Mr. Dean also suggested that the congratulations of the meeting be sent to the Rev. Canon Hole on his appointment to the Deanery of Rochester—a graceful proposal, seeing that the new Dean is a rosarian. Sir Guyer Hunter responded to the toast, referring to his experiences of gardening in India and the medals Lady Hunter won at flower shows in Bombay, concluding by wishing unbounded success to the National Chrysanthemum Society with which he had the pleasure to be associated. This very agreeable speech was much applauded.

Now followed a little bustling about and spasmodic breathings were heard, as if something serious was going to happen. I had now Mr. C. Gibson pointed out with Mr. C. Orchard near him, and they looked like two working bees, spare and active. "No better men in the room," said my guide. "Gibson has nearly swept the boards this year, and Orchard has helped to win a lot of prizes, but he wants a gardener's place again, and whoever gets him will get a good man." The bustling was preparatory to the presentation of prizes, this being evidently regarded as one of the events of the evening. The first was a handsome silver cup handed to the President for his splendid incurved blooms. He received it amidst cheers, and said though he had hundreds (I am not sure of the exact term), he should prize this most highly, and endeavour to win more, for though he was seventy years old there was life in the old dog yet. I am sure I am correct in that; and he clasped the shining goblet to his breast as if he loved his cups.

Mr. F. C. Jukes proposed the "Affiliated Societies" in one of the best speeches of the evening, "A treat," my friend remarked, and it was. Mr. J. Fraser gave the "Treasurer and Honorary Secretary," observing he had no idea he should be called on, and had nothing to say, but he had no difficulty in making something that met with warm acceptance. Mr. W. Holmes was entrusted with "The Committees General and Floral," remarking on the zeal and ability displayed by all, the proof of this being seen in the high position attained by the Society in the Chrysanthemum world. They could do more with more money, and if any friends were longing to help, perhaps someone would kindly wait on them. Several gentlemen responded to those toasts, one pleading the cause of the reserve fund, another for a better prize list, and so on, and all so earnestly and eloquently that the hands of the multitude could not be kept out of their pockets, and to relieve them it seemed necessary to send round collectors. Amidst all the laudits and endeavours to do justice to each other it was difficult to learn who had done most for the Society; each seemed to say that he had done nothing, but somebody else had done everything, until the compliments and disclaimers got so mixed that they could not be

separated. One jolly farmer-looking individual, however, said he had done something, for he thought he had got more medals than anybody, and a nice bit of money, and so the matter was settled.

Bringing proceedings to a close Mr. Addison proposed "The Press," saying they couldn't get on without it; and Mr. Wright, who responded, said neither could he very well, and didn't want very much. He hoped they would press on in their good work, as it was that which filled the press and made it interesting, and so forth. A few other complimentary toasts followed, Messrs. Barron and Head having the last words, their speeches being very much alike, and may be condensed into a sentence, "Isn't it good to be here?" That appeared to be what everybody thought, as the meeting broke up just in time for me to catch the last train from King's Cross.—A COUNTRYMAN.

### THE VEITCH MEMORIAL MEDALS.

It is a generally expressed opinion that the West of England is not very well treated with respect to the Veitch Memorial medals. Twice since their institution one has been offered at Exeter; but, unless I am much mistaken, no other society in the south-western counties has been similarly favoured. Before it is too late I ask, Why is this? and, further, Why has Bath been passed over in favour of Exeter, or, indeed, in favour of any other provincial town? No other society can possibly do more for horticulture than does the Bath Floral Committee, and all acquainted with the merits of the case will readily agree with me that the encouragement given has been far from creditable to the citizens of Bath, with a few noteworthy exceptions, and a recognition from other sources would have the best possible effect. Neither Mr. Pearson, the able Secretary, nor the Committee generally would, I feel certain, wish me to "go round with the hat" in their behalf; but they would fully appreciate the distinction of having one or more of the much-coveted Veitch Memorial prizes placed at their disposal by the Trustees, and horticulturists of all shades hereabouts would be glad to hear that this has been done.

No less than five good shows are annually held at Bath—a greater number, I believe, than any other town can boast of; and, consequently the medal or medals would not partake somewhat of the character of a "white elephant," unless, indeed, an embarrassment be felt in deciding to what particular class or classes they ought to be devoted to. First, they have an excellent bulb and spring show; next, a grand show in May, at which there are many fine collections of flowering and fine-foliaged plants staged, and to these last year were added an exceptionally grand collection of Orchids. Roses are wonderfully popular in Bath, and a really good show is invariably held. Early in September a two-days show is held, the great features in this case being Fuchsias, flowering and fine-foliaged plants, Ferns, Begonias, cut flowers, and, last but not least, a very excellent collection of Grapes, Melons, Peaches, and other fruit in season. The Chrysanthemum Show in November is, I can truthfully assert, second to none; this, after visiting several other highly reputed exhibitions. It will thus be seen there is good room for any number of Memorial and other special prizes and medals; not that exhibitors require any extra inducement to bring them to Bath. On the contrary, they turn up regularly in great numbers—a proof positive that the Bath Shows are most popular with this section of horticulturists, and ought to be recognised accordingly.—ON-LOOKER.

### ROYAL METEOROLOGICAL SOCIETY.

THE usual monthly meeting of this Society was held on Wednesday evening, the 21st instant, at the Institution of Civil Engineers, 25, Great George Street, Westminster, Mr. W. Ellis, F.R.A.S., President, in the chair.

The Rev. R. Barker, Mr. W. W. Day, M.D.; Mr. H. N. Dickson, Mr. H. Harries, Mr. P. S. Jeffrey, B.A.; Mr. H. A. Johnstone, and Mr. J. Wolstenholme were elected Fellows of the Society.

The following papers were read:—

(1), "The Mean Temperature of the Air at Greenwich from September 1811 to June 1856," by Mr. H. S. Eaton, M.A., F.R.Met.Soc. This is a discussion of the Meteorological Journals of the late Mr. J. H. Belville and those of the Royal Observatory. The general results of this investigation are:—1, That there was no appreciable change in the mean annual temperature of the air at Greenwich in the period 1812 to 1855 inclusive. 2, That on the eminence on which the Royal Observatory is situated the average temperature at night, or rather the early morning, is in all cases higher than over the lower grounds. 3, That with a north-wall, or possibly a north-window exposure, higher maximum temperatures are found at the lower stations. 4, That the movements of the thermometer are retarded with a south-wall exposure, as compared with an instrument on an open stand, especially where the situation is a confined one, the indications of the thermometer not following changes of temperature so promptly owing to the modifying influence of the adjacent building.

(2), "Report on the Phenological Observations for the year 1887," by the Rev. T. A. Preston, M.A., F.R.Met.Soc. The past season was a most exceptional one. For flowers it was disastrous; fruit was generally a failure, though there were exceptions; those kinds which promised well turned out very small or spoilt by insects. Vegetables were universally poor, roots were destroyed by insects or drought, and green crops soon passed off. The Wheat crop, however, was better than was expected. Barley on light lands was poor, but that which was sown

early was satisfactory. Meadow hay was not up to an average crop, but Clover and seed hay were much more nearly so. In Kent the fruit crops turned out lighter than usual, but the prices have ruled higher.

(3), "Earth Tremors and the Wind," by Prof. John Milne, F.R.S., F.G.S. The author has made a detailed examination of the tremor records obtained in Tokio, and compared them with the tri-daily weather maps issued by the Imperial Government of Japan. From this comparison the following conclusions have been drawn:—1, Earth tremors are more frequent with a low barometer than with a high barometer. 2, With a high barometric gradient tremors are almost always observed, but when the gradient is small it is seldom that tremors are visible. 3, The stronger the wind the more likely it is that tremors should be observed. 4, When there has been a strong wind and no tremors the wind has usually been local, of short duration, or else blowing inland from the ocean. 5, When there has been little or no wind in Tokio, and yet tremors have been observed, in most cases there has been a strong wind in the other parts of Central Japan. 6, from 75 to 80 per cent. of the tremors observed in Tokio may be accounted for on the supposition that they have been produced either by local or distant winds. 7, The only connection between earth tremors and earthquakes in Central Japan is that they are both more frequent about the same season.

(4), "Pressure and Temperature in Cyclones and Anticyclones," by Prof. H. A. Hazen. The author has made a comparison of the observations at Burlington and on the summit of Mount Washington, U.S.A., and as the result of a study of about 4000 observations from two days before till two days after the passage of cyclone and anticyclone centres, he has arrived at the following conclusions:—1, In both cyclones and anticyclones the pressure lags from ten to eleven hours at the summit of Mount Washington. 2, The temperature change at the base precedes very slightly the pressure change, but at the summit the change occurs nearly twenty-four hours earlier. 3, The temperature appears to be a very little earlier at the summit than at the base, and certainly varies much more rapidly at the former. 4, In a cyclone the difference in temperature between base and summit is less than the mean before the storm, but the difference rapidly increases after the centre has passed. Just the contrary is true in an anticyclone. 5, The total fall in pressure in a cyclone at the summit very nearly equals that at the base, and likewise the rise in an anticyclone. 6, The fluctuation of temperature, that is from the highest to the lowest, at the summit is double that at the base in a cyclone, but it is only a little greater in an anticyclone.

### CHRYSANTHEMUM NOTES.

#### USEFUL VARIETIES.

BEFORE the Chrysanthemum year closes perhaps a few notes from a "cut and come again" point of view may not be uninteresting or uninteresting. Several of the newer varieties tried have not proved so good as expected, though the treatment may have been at fault. Others have shown that they will be acquisitions of value, and many of the older varieties have well held their ground. Disbudding in almost every case has proved advantageous. We have not only disbudded, but in some cases thinned the shoots when they seemed too thick. In the notes which follow the remarks apply in all cases to disbudded plants.

One of the brightest varieties is Val d'Andorre. It is of a dwarf short-growing habit, the foliage large and of a pleasing shade of green; the flowers of good size, freely produced, and the brightest we have. This should be grown well, as it repays any extra care. Janira has given great satisfaction. It is very free-flowering, the blooms coming of a good size, and while unfolding the silvery centre is most attractive; when the bloom is developed it is of a suffused shade of violet, and under artificial light appears a crimson. Snowstorm is a white variety which attracts attention from some people, while others see nothing in it. It is most valuable where cut flowers are in demand, as the distinct form of this variety gives quite a decided character to an arrangement of flowers and foliage. Ornament is a rosy crimson sort, very free, and altogether a good variety, the form of the flower being very attractive. We look forward to this becoming a standard kind. Perhaps the best of all the newer kinds for the north is W. Holmes. This is a very free-flowering variety, the blooms coming a good size, but not too big, and its colour rich. Fernand Feral makes a capital bush, the flowers coming large, and colour bright.

As a good variety for the north perhaps none excels Lady Selborne. It is very free-flowering, and the flowers have the great merit of continuing fresh and unstained by age for many weeks. They keep good here for at least seven weeks, and no white variety yields so many flowers as does this one. The trio—Mrs. Rundle, Mrs. Dixon, and Geo. Glenny—are in their way extra fine, but they have the fault of turning pinky very quickly. Cloth of Gold is a charming shade of yellow. So is Phœbus, but this sport requires to be well disbudded to show itself in good condition. Peter the Great is still one of the best yellow sorts, so clear and soft. I like Gluck very much, and a really fine thing appears in Golden Fleecce, a summer-flowering sort, which I am increasing as rapidly as possible. La Vierge is also very good, in some respects better than Madame Desgrange, which, as a cut flower, is very apt to fall in pieces. Roi des Précoces has been grown for the past three years or so. It is very good, and the later blooms are quite distinct in shape and shade from the earlier ones. Margot shows the same peculiarity, the last blooms being much prettier than the first, this perhaps accounting for its name. Simon Délaux, Source d'Or, L'He des Plaisirs, Rex Rubrorum, Julie Lagravère, Reverie, M. J. Laing, Elaine, Fair Maid of Guernsey,



and Mdle. Lacroix are quite indispensable sorts. I very much like Fleur du Marie with a soft yellow when opening; Timbale d'Argent, bright green centre in the same stage; and M. Astorg and Ethel, which often show black centres when opened. These are not profitable, but they are pretty. Mary Anderson is a beautiful single white with yellow centre.

It is curious that varieties do not succeed so well in some places as others. I have noticed this repeatedly; but there are any number of beautiful sorts to pick from, and it would be a difficult matter to get up an Index Expurgatorius of these beautiful flowers, most sorts having some good point to recommend them, and most a good many.—B.

#### JUDGING CHRYSANTHEMUMS.

HAVING some years' experience at our local and other Chrysanthemum shows, I beg to add my testimony in favour of Mr. Wright's system. At our local show this year the competition for twenty-four incurved, and the same number of Japanese cut blooms, was very close, and utterly impossible to fairly decide except by "pointing," that is by agreeing to set a defined numeral value on every cut bloom and then adding the totals. If this system was adopted generally no such result would be likely as that referred to at Manchester—viz., "six equal prizes in five classes." Most judges know that except in the more evenly balanced classes "pointing" is unnecessary, a glance sometimes showing where merit lies. If this were not so, time in those short winter days would be insufficient.

#### "EARLY" VARIETIES LATE.

This was, in my experience of certain varieties, a peculiarity of the past season, in regard to plants grown outdoors against a protected south wall, and also indoors. Pynaert Van Geert, Henri Jacotot, Simon Délaux, and Fleur Eté, that are often in bloom mid-October, are now blooming with ordinary treatment with me, while Mandarin is only gone. M. Mousillae and Margaret Marroueh again are not quite expanded, and keeping company with Lady Matheson, Pelican, Ethel, Brazen Shield, Hero of Stoke Newington, and Princess Teek, which may fairly be considered late varieties, while I have seen the former in bloom the first week in November. As I mentioned Lady Matheson and Brazen Shield, I should like to ask some reader who has grown them, if they think they can be classed as Japanese? I am looking forward to a new edition of the National Society's excellent catalogue, with subdivisions of the Japanese section into groups, such as incurved, reflexed, general time of blooming, size, show or decorative, tessellated, and so on.

#### NEW VARIETIES.

Of those of last season that came under my notice, Carew Underwood for show purposes is certain to be largely grown. It was splendidly shown, both here and in Waterford, from Kilcronagh. Martha Harding I accidentally lost the best buds of, but it seems a fine variety, and has been commended by many growers. Avalanche, after Mr. Molyneux's opinion, "the finest white Japanese Chrysanthemum in existence," hardly requires further testimony. For some reason the season seemed not favourable to Maiden's Blush or Phœbus, yet few large growers will care to be without both. Of Ralph Brocklebank, Mr. and Mrs. H. Cannell, Edwin Molyneux, Mrs. J. Wright, M. H. Elliot, Bertha Flight, and Lady T. Lawrence, with others I have had recently fine blooms from Swanley, and apart from the fact that all those have received first-class certificates, if I remember rightly, there can be little doubt that they are destined to become standard varieties. Carter's Bronze Queen, also Mrs. Norman Davis and Lord Eversley, both sports from Princess Teek, are I believe the only real additions to the incurved, while Amy Furze (doubtfully) is the solitary reflexed admitted. There are to be still added such new certificated varieties as Agnes Flight, Mr. C. Orchard, Edouard Audiguier, Macaulay, Duke of Berwick, Mr. Garnar, Album Fimbriatum, and J. Collins.—W. J. MURPHY, *Clonmel*.

#### AMY FURZE, CHRYSANTHEMUM.

I BEG to thank "A Judge" for his reply. My principal object in writing was to point out the anomalous position held by Amy Furze. That some confusion existed and does exist is admitted by "A Judge" in his reply. That being so, should the National Chrysanthemum Society think proper to provide a class for reflexed Japanese it will, I presume, have a similar effect to that proposed by myself—namely, placing such varieties as Elaine and Dr. Macary, as well as the variety under discussion, in a more satisfactory position. I should like to see all new varieties thoroughly tested before being certificated, and when classed be judged on their merits as flowers, and not as now, when the variety in question is (according to "A Judge," page 499) a reflexed during early maturity, and a Japanese when in its prime. May I ask do flowers of Dr. Sharp and Cloth of Gold answer to the required standard by the quotation from "An Experienced Judge" (page 546)? and if they do not, do they also lose points? When I turn to my schedule I find a class for reflexed, when to a catalogue a list of reflexed, but nowhere the hard-and-fast line insisted on by "A Judge," and confirmed by "An Experienced Judge" on page 546. Will either of those gentlemen kindly give your readers a short list of varieties answering to this standard? by so doing he will greatly oblige others who are deeply interested in this matter, as well as myself. It would be very interesting, and not a little instructive, as showing the unanimity of opinion (which "A Judge" seems to assume exists), or otherwise of judges generally, if exhibitors who may here set up good flowers of Amy Furze have had their position strengthened or weakened thereby. I

have a notion that judges, like other men, have each their peculiarities or leanings which in time become well known, so that some very shrewd and successful exhibitors, acting on the old adage, "to be forewarned is to be forearmed," cater accordingly.—T. W.

#### CHRYSANTHEMUM MRS. J. WRIGHT.

It may not be generally known that this very fine new Japanese Chrysanthemum is capable of producing late blooms. About the middle of November I cut two large blooms from one plant. Upon the stems bearing blooms cut I noticed at each leaf for about 1 foot 6 inches down the stem flower buds were formed, which by their appearance promised to yield flowers later on, consequently the plant was given some assistance in the shape of liquid manure occasionally. The result was a number of beautifully developed flowers more purely white (if it were possible) than larger flowers produced at the ordinary time—middle of November. These late flowers were cut on Christmas day.—E. MOLYNEUX.

#### PRIMULA SINENSIS.

CHINESE Primulas have never been so diversified in the colours and forms of their flowers, nor so well grown as they are at the present time, but it must be remembered that over sixty years has been required to bring them to their present state of perfection. In private gardens, nurseries, and market gardens Primulas are now almost indispensable in the winter months, and the enormous number of plants raised every year from seed would be astonishing if the total could be known. Yet their popularity is still extending, owing to a great measure, to the continued efforts of hybridisers to improve the quality of the flowers and increase the number of distinct and meritorious varieties. The trade growers have paid such close attention to the plants, and have exhibited such admirable examples of their skill, that the general system of culture has been greatly improved. The long drawn plants with loose straggling umbels of flowers that were at one time characteristic of the Chinese Primula are now rare exceptions, and compact specimens with sturdy well developed foliage and dense trusses of flowers just rising above the leaves are the rule.

Though many now well-known Chinese plants were introduced before the close of the eighteenth century, yet this Primula does not appear to have been brought into cultivation here until 1821. In that year an illustration was published in the "Botanical Register" (t. 539), under the name of *Primula prænites*, which Mr. Sydenham Edwards said was "drawn from a plant (we believe the only one in the country) which flowered last March in the collection of Mrs. Palmer, at Bromley, Kent. It had been brought by Capt. Rawes from the gardens at Canton, where it probably found its way from some more northern quarter of the Chinese Empire, none of the genera having, we believe, been observed as native of the levels of so low a latitude. Samples in a dried state had been previously transmitted by Mr. Reeves, a gentleman in the employment of the East India Company at Canton." He farther observes that the name *sinensis* by which it had been mentioned by Mr. Sabine would have been adopted, but Loureiro in the "Flora Cochinchinensis" had previously described a Primula under that name. Four years later—namely, in 1825, a figure also appeared in the "Botanical Magazine" (t. 2564) under its present accepted title, with a reference to Hooker's "Exotic Flora," where it was also described as *Primula sinensis*. In both the illustrations noted the trusses depicted are large and loose, two whorls of flowers on slender pedicels  $2\frac{1}{2}$  inches long, five to seven flowers in a whorl. The corollas are  $1\frac{1}{2}$  inch in diameter, rosy crimson, but not of good shape as it is understood at the present time, the spaces between the lobes being wide. As early as that the variability had been remarked, especially in number of teeth in the calyx and the variously jagged margin of the corolla, and some doubts had been entertained as to whether it was properly classed in the genus *Primula*. Dr. Hooker, however, thought there were "two distinct varieties," though others attributed the variations noticed to the effect of cultivation.

The plant was welcomed by both nurserymen and amateurs, but it became especially popular on the Continent, and in 1826 is repeatedly mentioned as a general favourite in France and the Netherlands. About that time a large collection was grown at Chiswick, as well as by the leading metropolitan nurserymen, so that it was soon a familiar plant in greenhouses. Two or three varieties only are mentioned in lists for some years, and though many forms must have been occasionally raised, no effort was made to fix them. After the Floral Committee of the Royal Horticultural Society was instituted in 1859, the number rapidly advanced, and from then up to 1884 no less than fifty-three were honoured with certificates. From the latter date until 1887 twelve varieties were certificated—a much larger proportion in the time; and as half these were from one firm (Messrs. Sutton & Sons), it is an indication that they possessed some special qualities.

In their nursery and seed trial grounds at Reading, Messrs. Sutton and Sons have now a fine representative collection of Chinese Primulas, to which a few notes may be devoted, as showing the types and the extent of variation now obtained. They can be conveniently classed in three large groups:—1, Plain-leaved varieties; 2, Fern-leaved varieties; and 3, Ornamental-leaved varieties; each of which can be subdivided into the forms with single and double flowers.

*Plain-leaved Primulas*.—These form the original type of *P. sinensis*, with the leaf blade palmately lobed or nearly circular in outline, and as they radiate regularly from the centre of the plant they form quite a rosette of foliage with the trusses of flowers rising from the centre. The single varieties comprise Giant White and Alba magnifica as the most



remarkable of the white flowered series, both with large solid flowers, the corollas of great substance, beautifully formed, and pure white. In the coloured varieties there are many rich and delicate tints, Reading Scarlet being one of the brightest. Improved Chiswick Red is a standard variety. Ruby King is of a peculiar handsome ruby crimson shade. Imperial Purple is very rich crimson purple. Reading Purple is similar, of a fine deep colour. Grand Lilac is a fine type of the mauve tinted varieties, and Advance is a soft rose with a large truss, Pearl being, as its name implies, a delicate pearly white. Lastly, there is Reading Blue, which is very distinct from the others in its colour, and looks well when arranged with them. Besides these there are mixed strains of single varieties, comprising the good points of most of the preceding, and sometimes yielding promising novelties.

The double varieties of this section are numerous, and comprise some useful plants, as the flowers last so long. The best and most distinct only are selected as named varieties, and of these the names Double Scarlet, Double Rose, Improved Double Carmine, Double Blue, Double White, and Double Carnation Flaked, well indicate the respective tints. The Double Blue is a decided acquisition, as the flowers are well formed and the colour good. The Carnation Flaked is prettily marked or mottled with rose and white, very distinct. The special hybrid strain includes semi-double and double varieties of many tints, and the mixed double strain is similar.

**Fern-leaved Primulas.**—The production of a variety with long instead of rounded leaf blades, and more or less cut at the margin, formed a peculiarly interesting break amongst the Chinese Primulas, and they now constitute a distinct group. It was about 1860 when the first of this type was brought prominently before the public under the name of *Filicifolia*. Since then many forms have been raised from it, presenting almost as much variation as the ordinary plain-leaved type. Of the single varieties in Messrs. Sutton's collection the best are—Rosy Queen, Rosy Lilac, a specially beautiful form with neatly fringed flowers; Snowdrift, very pure, and the ordinary Red or White Fern-leaved. The doubles are not quite so abundant, but the Double Blue and Double White are excellent, with fine substantial flowers and beautiful leaves.

**Ornamental-leaved Primulas.**—This is quite a new group, though we may look for a considerable extension now it has been commenced. A remarkable variety at Reading is Gipsy Queen, which has dark-bronzed metallic-like foliage, and white or rose-tinged flowers, a very striking contrast. The Moss-curl is, however, the most peculiar, the leaves being of a light fresh green, deeply crisped and curled at the margin, and the flowers white or lilac, single or semi-double. These make a pleasing margin to a group of the other varieties. Variegated or golden-leaved forms have been obtained, but not thoroughly fixed at present.

—V.

## HYBRIDISING AND CROSS FERTILISATION.

(Continued from page 521.)

THE discussion following the reading of the paper already given brought out several interesting matters, the principal contribution being by Mr. Henry Bennett of Shepperton, who was attending the Convention, and was introduced by the President, Mr. Robert Craig, and Mr. Peter Henderson in flattering terms, stating that "his marvellous Roses had made his name a household word all over America."

Mr. Bennett said—Mr. Chairman, Ladies and Gentlemen: I was much interested in Mr. Thorpe's remarks, though I could not quite catch some of them. Hybridisation came in first, as we know, by crossing various species, not with a commercial object in view, but scientifically. I have not much to say on this subject, and indeed have not much voice with which to say anything. But one remark of Mr. Thorpe's leads me to say that I do not think people need be discouraged in hybridising because of a fear of insects operating on the flowers. My opinion is that you have only to divest what you are operating on of the colour or the petals, and that you thus remove the source of attraction for the insects. You thereby interfere so with Nature that you deceive the insect kingdom. I think that the scent may in some instances attract insects. The scent may not be taken away when the petals are gone, but I believe that the great attraction for insects is the colour of the petals. I took my cue in this from Charles Darwin, who contended that the colour of the petals of the flowers was the cause of attraction for insects. When you have removed the petals you are free from insect interference in my opinion.

In Roses, by the use of a crimson male you can get a crimson colour from a white female of the Hybrid Perpetual class, but no one has ever yet got the yellow into a Hybrid Perpetual. Whether it will ever be done we cannot tell. The yellow in the *Polyantha japonica* once fertilised will produce a yellow almost to a certainty. If you fertilise with the yellow variety you will almost certainly get a yellow with it, even though you operate on a white flower. One important matter in hybridising for commercial purposes is this: you are to pay particular attention so as to secure a high quality in the male plant. There is very little difference between the lines in the plant kingdom and those in the animal kingdom. You will get better progeny from a moderate female with a good male than you will get from a thoroughly good female and only a moderate male. Of course the better the parents the better the results. I have had many good results from a bad female, but never succeeded in getting good flowers from a bad male. I think there is nothing more that I can say about it at present. The matter

is one that lies within narrow limits, and it must be remembered that long time is required to work it up.

Before returning to my seat, let me say that this is the first time have crossed the Atlantic, and I cannot let the opportunity pass without thanking you all for the very great kindness I have received in this city. It has been more than I expected, and I shall hold it in remembrance as long as I live. I thank you all for the attention you have given me. (Great applause.)

President Craig.—Ladies and Gentlemen: I am sure that we all feel grateful to Mr. Bennett for giving us so freely from the store of his knowledge. It was hardly fair to call upon him without any notice whatever, and I certainly feel that I express the sentiments of all present when I say that we are extremely grateful to him.

Mr. D. S. Heffron of Washington Heights, Ill. (after an urgent invitation from the Chair for a continuance of the discussion) said: What I have to say is testimony in part to what Mr. Bennett has said in reference to the selection of parents for fertilisation. I have experimented some in crossing Cannas, Callas, Grapes, and Potatoes. I have succeeded better with Potatoes than with the others, as many people know. I select first the mother plant, and in doing that, I endeavour to get one that has a healthy constitution—one that is a good strong grower, and is of the form that I want to have perfected. Then for the male plant I select one of the requisite colour, and of the other characteristics that I want to reproduce. In crossing the two I could scarcely fail to get something better. Not all of them may have been better, but many of them were better than the parents. I think, from my own limited observations, that that is a good rule, and I throw it out for what it is worth, that you may think of it for yourselves—viz., in the female parent get the strong, healthy-growing plant of the right height, and then in the male plant look to the colour and the form of the flower.

Mr. Wm. K. Harris of Philadelphia (who was called upon by the Chair as one who had done much useful work, particularly in the Geranium line), said he could add nothing to what had been so well said by the gentlemen who had preceded him, as the methods stated by them were substantially identical with those which he had adopted, with results similar to those just described. The gentlemen had spoken of selecting the male and female plants for colour, form, &c. He (Mr. Harris) had also been governed in his selections by the apparent strength, health, and other characteristics of the parent stock. As a general thing, he had been successful in the results obtained, seldom failing to get something superior. Of course he had not been successful in every instance. He had found that, by scientific methods, the grower was certain to obtain at least a few flowers of superior quality; whereas, if Nature was unaided, thousands might be grown without the appearance of anything having a quality above the ordinary average.

Mr. John N. May of Summit, N.J. (having been called upon by the Chair) said—Mr. President, Ladies and Gentlemen: For some years I have been experimenting to some extent on Roses—that is, so far as hybridisation goes. I am not an experimenter in the growing of Roses. In the hybridisation, to attain a colour, I find that we are obliged to select—as the gentlemen who have preceded me have stated—not only a good strong constitution, but we have to select very carefully the colours which we wish to have perpetuated in our new seedling. I had an idea in my head some years ago that I wanted to improve the colour. To do this I found to be a more difficult matter than I had anticipated, for the reason that while we already had the yellow, we had not the extreme colour that I wanted. As I understand it, we cannot create from Nature a primary colour, we can only assist Nature. Scarlet has never yet been produced in the Rose. Appreciating this fact, I made it the object of my researches to obtain the nearest possible approach to a scarlet. To that end I took *Général Jacqueminot* and fertilised it with *Perle des Jardins*. The result is a Rose which is ten shades brighter in colour than any known Rose at the present day. That is simply the result of one of the experiments that I have definitely accomplished. (Applause.)

A Delegate.—Will Mr. May state which was the male parent?

Mr. May.—The male parent was *Perle des Jardins*.

President Craig (after an interval of waiting) said: The Chair would much prefer that members would take part in the discussion voluntarily, so that the distasteful task of calling upon them may not be imposed upon the Chair. The modesty of the gentlemen present is such as to leave your presiding officer no alternative, and the Chair would therefore call upon Mr. Charles T. Starr, of Avondale, Pa. (Applause.) That gentleman has given us some varieties of Carnations that are standard—some that no florist can afford to do without. Now, if he will just tell us how he got those results, or give some idea about it, we will feel very grateful to him.

Mr. Charles T. Starr, of Avondale, Pa., replied: Mr. President, I am not accustomed to speaking to an audience of the size of the one before me, and I may therefore encounter some embarrassment in stating my ideas in the way that I would like to state them. I originated the *Buttercup Carnation*, as perhaps you all know. That has been long years ago, and I may state also that it was done, as I might say, with my eyes shut, because I was without any known law to go by. It was produced from the cross of *Edwardsii* as the female parent and the old *Astoria* as the male parent. In the crossing of the *Edwardsii* with the *Astoria*, I obtained the colour of the young plant from the *Astoria*. The statement has been made here that the colour of the male is generally reproduced in the cross fertilisation, and

in the case of the Buttercup the colour would come from the Astoria. But the constitution of the Buttercup is entirely different from that of the old Astoria, the latter being rather a weak grower, and it is difficult to tell whence the constitution of the Buttercup came. We are now striving to get a good rose colour with Grace Wilder as the male parent, and the Edwardsii as the female parent. Some little time will have to elapse before the result of this effort is developed. We have a very good orange colour, which was produced by fertilising the Buttercup with the Century, the result being a very bright or deep orange. I might add a word in regard to the growing of the seed, or producing it after the fertilisation. It is this: About two days after the flower has been fertilised, if a union has been formed, the petals being to curl. We then cut the petals off to the top of the calyx. That is necessary, as otherwise the seed will be likely to mould, as we generally grow the seed in the greenhouse altogether in the spring months. We find February the better time for fertilising the Carnation. As soon as the seed has become ripe we plant it at once before it becomes dry. I have known Carnation seed to come up and develop in three days. It is necessary to be very careful of the little seedlings after they have developed their second leaf, else they will damp off at the top of the ground. We then pot them in small pots, grow them for about a month, and set them out in the open ground.

Mr. W. Hughes, of Hillsdale, Mich., inquired as to the *modus operandi* of the crossing of the male and female plants.

Mr. John Thorpe of Queens, N.Y. (being deputed by the Chair to reply), said: All seedlings are the result of sexual intercourse, as you know; and unless the conditions of the female plant are such as to enable it to receive the pollen from the male, you will not have any seed. The mechanical application is simply the transferring of the pollen of the male to the stigma of the female plant. It is one of those things which it is difficult to describe, but which may be readily understood.

Hon. C. C. Cole of Des Moines, Iowa.—I did not understand Mr. Bennett's statement of how the fertilisation on the petals by insects could be prevented. He said it was easily done, and stated the process of preventing it, but I did not understand his statement.

Mr. Henry Bennett of England.—Perhaps I had better say a word or two further on the point with regard to the prevention of insect interference. I really took my ideas from Sir John Lubbock and Charles Darwin. They both say that the colours of the petals of flowers constitute the attraction for insects which are bent on extracting the farina or honey from flowers. After operating on the flowers by taking the petals away, you need have no fear of any interference from the insect kingdom. That is the result that I have found. Three have been many experiments tried by Sir John Lubbock with bees on coloured paper. The bees are more attracted by the colours than by the honey or anything you put on the flowers. So that if you take the colours away you remove the attraction. I, myself, have done this; and my whole experience has proved the efficacy of the remedy. I have never detected the insect fertilisation on a flower on which I have operated, and I do not believe it will be detected in any case after such an operation.

Mr. L. B. Pierce of Talmage, O.—Will the seed mature just as well?

Mr. Bennett.—Yes; it will. Most flowers are bi-sexual, and these are more difficult to treat than those which are of either sex. If you want variations the way is to take out the bearing organs before they burst. If you get seed from that part of the flower after that, you are certain to have a new variety, whether it is interfered with manually or by the insect kingdom. In view of the great demand that exists for distinct varieties, it is almost impossible, in our day, to keep pace with the times if we wait for variations in the natural way. (Applause.)

### PLANT NAMES.

[A paper read at a meeting of the "Chiswick Gardeners' Mutual Improvement Association," on December 21st, 1887. By F. W. Burbidge, F.L.S., M.R.L.A., Curator Trin. Coll. Botanical Gardens, Dublin; formerly of the R.H.S. Gardens, Chiswick; and also of the Royal Gardens, Kew.]

(Continued from page 545.)

ONE may safely say that plant names are well-nigh coveal with human speech, and further that the earliest of plant names were in reality short descriptions, rather than the terse binomials adopted since the days of Linnæus. Thus the common "paper white" or *Narcissus papyraceus* of to-day, was figured in 1612 in the great "Hortus Eystettensis" as "*Narcissus orientalis polyanthus minor totus albus*," that is to say, "The Eastern Narcissus, having many flowers on a stalk," these being small in size, and altogether white in colour. I take this plant as an example partly because I think I know more of *Narcissus* than of any other flowers, and so feel myself to be on safe ground, but I also allude to *N. papyraceus* because this season, for the first time, the bulk dealers and nurserymen are offering as "new" a large flowered form of the "Paper White Narcissus" for forcing purposes, and, singular to relate, this large-flowered kind is also figured by Besler, in the aforesaid "Hortus Eystettensis," under the name of "*Narcissus orientalis medius totus albus polyanthus*," so that instead of this plant being new, it is figured in 1612—that is, four years before the death of Shakespeare. But for the beginning of plant names we must go back to a much earlier period. The great Indo-Chinese region, although rich in legendary traditions, yields us very few ancient records

of plant names that can be absolutely fixed to the species of to-day, and the same is true in a lesser degree of that great centre of learning and luxury—the Egypt of four or five thousand years ago. But we do know something of the plants cultivated by the Egyptians, such as the Onions, Garlic, and Cucumbers for food, and the Nelumbium, the rosy and blue Water Lilies for beauty and religious rites and ceremonies, not forgetting the Papyrus (Paper Rush), on which as paper perhaps the earliest of Egyptian written (as opposed to stamped or incised) records were inscribed. Now, in relation to plant names, this Paper Reed or Papyrus is very important, since two of the most interesting words in our language have derived their origin from the names long ago applied to this plant. The word "paper" is simply a shortened corruption of Papyrus itself, but the Greeks knew the Papyrus of Egypt or its products as "Byblos" whence we have derived our name "Bible," meaning a written document (as a papyrus scroll or book), and now almost sacred in its usage for that oldest and best of all books, the Scriptures—as bound together in one volume. I need scarcely ask you to remember that the chronology which has for years been adopted—that makes the world only about 6000 years old—is now believed to be very much short of the real truth; but, of course, the real distance of time since the beginning is now unknown, and perhaps unknowable. It is sacred history which informs us of the reviling of Moses (B.C. 1500) by the Israelites when they asked him in their wanderings in the desert, "Who shall give us flesh to eat?" We remember the fish which we did eat in Egypt freely, the Cucumbers and the Melons, the Leeks, the Onions, and the Garlic." Now Herodotus, the celebrated Greek traveller and historian, who lived B.C. 484-406—that is to say, about one thousand years later than Moses—corroborates the sacred story and tells us that it was Cheops who built the great pyramid in twenty years, for his own tomb, with one hundred thousand men, and that it was he who degraded the Israelites to servile labour—and Herodotus is also particular to inform us that the "Radishes, Onions, and Garlic" eaten by the builders cost no less a sum than one thousand six hundred talents (Greek talent of silver—£243 15s.).

Perhaps the earliest of written plant names occur in the Hebrew version of the Scriptures, the first being, "And God said, Let the earth bring forth grass," &c. (Genesis i., 5, 11). Noah's having planted a vineyard after the flood, and that he drank to excess of its produce, is another example, setting aside the well-known Garden of Eden, in which the first gardener, Adam, was installed and employed. You will observe that even before the fall he was to labour to dress and keep that garden even in his innocenece and new-found life and joy. The first of all plants mentioned in the Bible is the Vine, but "Saffron" (*Crocus sativus*) is mentioned in the "Song of Solomon" nearly a thousand years before Christ. But the transcribers from the Hebrew into Greek and Latin, as also the English translators, have not always agreed as to what was really intended by the earlier scribes. We may for example take the well-known passage, "I am the Rose of Sharon, and the Lily of the Valleys." Now, to-day in gardens the "Rose of Sharon" is *Hypericum calycinum*, and the "Lily of the Valley" is *Convallaria majalis*; but it is pretty certain that neither of these plants was intended, neither being natives of Palestine. The Hebrew word translated "Rose" is "Chabatsteleth," and the best of etymologists tell us that some bulbous plant is evidently by it intended. The Targum has "Narcissus," the Vulgate or Latin version "flos campi" (flower of the field), while "Sharon" also may be translated as field or plain. Now amongst bulbous plants "Crocus," "Colehicium," "Anemone," and "Sternbergia," have been suggested, but Canon Tristram, of Durham, and other learned authorities, lean towards some Eastern form of *Narcissus* Tazetta having been the flower intended in the Hebrew version. Even Pliny, who was born twenty-three years only after Christ, and so was ten years old at the time of the Crucifixion, tells us that "Narcissus is a sort of Lily with a white flower and a purple cup," and in the botanical work of many centuries later we find Tulips mentioned under their older title of *Lilio-Nareissus*. As a fact botanical names were in an ever changing state of chaos until the days of Rauwolf, and of the great past master Linnæus, who decreed that a plant should possess two names only, a generic or family name, say Brown or Smith, and a specific or surname like Tom or Frederick William. At the same epoch began that Mede or Persian-like law that a plant once named and figured or described, should always retain that name unless it had been previously applied to another species. In the early days of botany, long after Linnæus even, posts were slow and erratic, and other communication between the leading botanists was so incomplete, that it often happened that the same species were named two or three times over by different people, in different, or even in the same country. Hence that array of synonyms which prove confusing to the uninitiated.

We must now retrace our steps a little, and remembering that the Hebrew scribes were certainly among the first to mention plants in writing, we must also remember that the papyri or paper literature of Egypt was in the main destroyed at Alexandria. But there are stone carvings in Egypt supposed to be nearly 6000 years old, which represent plants, and in the museum at Cairo (I believe also at Kew and the British Museum) are actual flowers taken from mummies known to be at the least 3000 to 4000 years old.

Herodotus tells us of two kinds of Lotus growing in the Nile—viz., the Water Lilies, the Poppy-like heads and fleshy roots of which were eaten by the Egyptians, and he also alludes to the Nelumbium, and firmly establishes its identity with the Nelumbia of to-day by saying its fruit resembles a wasp's nest. But in the tomb of Phtah-hotep, a high



functionary who lived at Memphis 4000 years before the Christian era, are scenes in bas-relief representing the ingathering of the Grape harvest, and the bruising it with the feet, and other scenes remind us of the bibulous weakness of the great ark builder, since they represent people in the state of those who do not take wine in moderation. We need not pretend to talk of the deterioration of our modern cultivated fruits, when these bas-reliefs of Memphis speak to us across a gulf of five or six thousand years, and show the produce of the Vines of Egypt at that time to have been as fine as the Grapes of to-day.

(To be continued.)



#### HARDY FRUIT GARDEN.

**FILBERTS AND COB NUTS.**—These are a very profitable crop in Kent and some parts of Sussex, and in most districts they pay for good culture. They succeed admirably when planted in rows midway between the lines of standard Apple and Pear trees, or a piece of good ground may be given wholly to them, the bushes being disposed about 9 feet apart each way. Frequently they are grown outside the garden walls in a line next the shelter trees or tall hedgerows. Here, thanks to the shelter afforded by these trees or hedgerows, good crops of Nuts are often secured when those in the open have failed to bear. Cold frosty winds are most injurious to the delicate blossoms and catkins of the Filberts and Cobs, hence the advisability of affording them some kind of shelter. The bushes or trees that produce those extra fine bunches of Nuts are invariably pruned and well attended to, being raised and trained much the same as a Red Currant bush. The start being made with a strong-rooted sucker, this is first cut down to within 15 inches of the ground, and supposing this results in the formation of three strong well placed branches, these must the following winter be cut back to within 4 inches of the main stem. Six branches, or sufficient for laying the foundation of a good bush, should then be selected and staked out in a circle, the centre being kept quite clear. In order to have these main branches both stout and well furnished with bearing wood they must be gradually "built up," being at the winter pruning cut back to about 12 inches in length, or still harder if weakly. During the summer following a well placed growth should be selected, a leader on each branch, and staked if need be, the other coarse lateral growth being lightly shortened. This to be an annual practice till a height of about 6 feet is reached, when they may be stopped constantly. The winter pruning consists of freely shortening back all the long growths and old bearing wood, leaving the catkin-bearing spray untouched. Thus treated they soon commence bearing freely, and immense clusters are usually produced. These, in common with ordinary fruit trees, should be kept cleared of all sucker growth, and be freely manured at least biennially. Naturally grown bushes and trees are, however, more common than the trained and closely pruned bushes just described. Even these merit better treatment than is usually given them, or otherwise the produce is but slightly superior to the Hazel Nuts. For instance, the ground about the stems may well be cleared of suckers and weeds, say as far as covered by top growth, a liberal dressing of half-decayed manure being then lightly forked into the surface. A little thinning-out of the branches is not thrown away, and any old and rather stunted trees may with advantage be cut down to within 18 inches of the ground. This will be followed by a thicket of young growth, which ought to be freely thinned out early in the summer. A new tree may be then formed either on the lines just laid down or by allowing the branches to grow naturally. Anyway, a marked improvement in the quality of the Nuts will soon be apparent. Both the common red and white Filberts are suitable for planting, and the thin-shelled or Cosford is reliable and good. The Spanish and dwarf Prolific Cobs are large and free-bearing, and may well be planted in quantity.

**WINTER DRESSING FOR WALL TREES.**—Fruit trees of all kinds, and more especially those growing against walls, require a winter dressing for the purpose of destroying insect pests nearly or quite as much as do those under glass. Pears are infested by scale, Apples by American blight, Peaches by aphid and red spider, Apricots by red spider, Cherries and Plums by aphid, all being more or less injurious to the trees. Now, or while the buds are dormant, is the time to exterminate them. At no other time can it be done so thoroughly and simply. Gishurst compound mixed and applied exactly as the vendors direct on each box is, no doubt, a good remedy, plenty of practical gardeners using no other insecticide. Some, however, prefer the hot water and petroleum dressing. The water should be heated to a temperature of about 120°, and to every 3 gallons should be added 6 ozs. or three wineglassfuls of petroleum, or paraffin as it is more commonly called. Ordinary 8-oz. medicine bottles are found very handy for measuring the oil. Some further add a lump of softsoap of near the size of a hen's egg to each 3-gallon can of water. The old directions as to preventing the oil from collecting on the surface of the water remain good. We set two syringes at work, one being constantly and forcibly discharging back into the

can, the other distributing the temporary mixture over the trees. If only one syringe is used the contents every other time must be discharged into the can. The oil without water would be injurious, and water without oil of no avail. A second dressing may sometimes be necessary for Pear trees.

#### FRUIT FORCING.

**VINES.**—*Earliest Forced.*—Great care is required at this time, being careful to avoid chills, such as those resulting from cold currents of air and watering the borders with cold water. Now the foliage is becoming active, root action will be excited, and should be encouraged by supplying tepid water at a temperature not exceeding 90°, and not allowing the fermenting materials to decline in heat at this critical stage. It is a good plan to keep a heap of leaves and stable manure in reserve, from which the supply may be drawn as required. Disbud and tie down before the shoots touch the glass, not being in too great a hurry in stopping, nor restricting to a certain number of joints beyond the bunch (yet there ought to be two, and better three or four), but extend the growth so as to insure a supply of well-developed foliage all over the house, avoiding overcrowding. Remove superfluous bunches as soon as choice can be made of the best, avoiding overcropping. Keep the house at 70° to 75° by artificial means as the flowers open, and maintain a rather drier condition of the atmosphere. Vines in pots should as soon as the fruit is set, be copiously supplied with liquid manure, maintaining a moist atmosphere. Damp the paths two or three times a day, and occasionally with liquid manure, keeping the evaporation troughs charged with the same.

*Houses to Afford Ripe Grapes in June.*—The Vines that are to supply these should be started at once, abundance of fermenting materials being placed on the outside border, or if it be already protected with a good thickness of dry fern or litter, fermenting materials may be dispensed with, and if wooden shutters or glazed lights are at command for throwing off the wet it will be an advantage. Water the inside border thoroughly with water at a temperature of 90°, and economise fuel by the free use of fermenting materials being placed inside the house. Damp the house and Vines two or three times a day when the weather is bright, but in dull weather once or at most twice a day will be ample. The temperature should be 50° to 55° by artificial means, and 65° from sun heat.

*Houses from which the Grapes have been Cut.*—The Vines should be pruned with as little delay as possible. Cut to a plump eye or bud as near to the main stem as possible. This will cause the spurs in course of time to become long; and so they do by any mode, but it is easy to train up young canes for the displacement of there. All loose bark should be stripped off, no attempt at scraping being made, and the Vines washed with softsoap and water. Avoid pigments which leave a deposit on the Vines calculated to interfere with their power of respiration. Remove the surface soil or mulching down to the roots, and replace with fresh material. The house should be kept cool, but, if utilised for plants the temperature artificially should not exceed 45°; indeed plants that require safety from frost only should be placed in vineries when the Vines are at rest.

*Late Houses.*—Maintain a mean temperature of 45°, with a dry atmosphere in houses in which Grapes are hanging. Examine every bunch frequently, and remove all decayed berries. Ventilate the house on fine dry mornings, and keep it closed when the weather is damp. Where late Grapes were ripened comparatively early, and it is desired to start the Vines soon after the middle of February, the Grapes may be cut, the ends of the stems being inserted in bottles of rain water secured in an inclined position so as to admit of the fruit hanging clear of the bottles. Any dry room will be a suitable place where an equable temperature of 40° to 45° is maintained. This will admit of the Vines being pruned and the house cleaned.

#### PLANT HOUSES.

*French and Fancy Pelargoniums.*—The plants intended for early flowering are now well established in 5-inch pots, and are sturdy little specimens with five or six shoots. Arrange these near to the glass, where a temperature of 50° to 55° can be maintained. Keep the atmosphere moderately dry, and water the plants carefully at their roots. Admit a little air daily when the weather will allow of this being done. A firm sturdy growth must be encouraged, or they will run up tall and weakly. This will spoil the appearance of the plants, and they will not flower freely. Directly flower buds are visible give the plants a little artificial manure on the surface of the soil, which may be repeated at intervals of a fortnight until they are in full flower. Bushy young plants in 3-inch pots may be placed into 5-inch pots for succession; these should be potted firmly in loam, a little sand, and one-seventh of decayed manure. After potting return them to the position close to the glass that they have been previously occupying, in a night temperature of 45°. Pinch the shoots of later plants in the same size pots, and also of all old stock plants that need it.

*Zonal Pelargoniums.*—Those well established in 5-inch pots, whether single or double varieties, may be treated the same as advised for French and fancy varieties that are required early. All that are in 3-inch pots may now be placed into 5-inch, except any few plants that are not ready, which can be left a few weeks longer. These will grow slowly if placed close to the glass, and a temperature of 45° maintained at night. All that are not needed in flower before the middle of May may have their shoots again pinched as soon as they are established and have made



2 or 3 inches of growth. Old plants that have been resting since November may be pruned, provided they are dry at their roots, and kept in this condition until they break into growth. A vinery where the temperature is kept at 50° will suit them well. If it is necessary to increase the stock of any of the plants that are cut back cuttings will root freely enough if placed singly in small pots and placed on a shelf in a temperature of 65°. It is not wise, however, to commence propagating for another month except the stock of any variety is limited and it is necessary to increase it as much as possible. Plants in flower must have a temperature of about 60° with a moderately dry atmosphere. Do not throw more water about than is absolutely necessary, and be careful to remove at once all dead and decaying flowers.

*Petunias*.—Place a few of the most forward plants now in 3-inch pots into 5-inch, and allow them to come into bloom. These may be placed with the early flowering Pelargoniums. A little leaf soil may be used in the compost for these plants, and the soil need not be pressed quite so firmly. Pinch the shoots of young plants intended for succession, and when they have broken into growth place them into 5-inch pots.

*Heliotropes*.—Young sturdy plants with about four shoots in 3-inch pots may be placed into 5-inch pots, and introduced into a temperature of 60°. Pot them firmly in loam, one-seventh of manure, and a little sand. If these are kept close to the glass they will soon come into flower. Pinch the shoots of young plants to insure their forming four or five shoots. Standards, pyramids, or bushes that have ceased flowering may have their shoots neatly tied, not pruned, and if top-dressed with a little rich material and placed in a temperature of 60° will soon start into growth, and soon be in full flower again. These will not produce such large trusses as the young plants, but if they are healthy they will make short sturdy growth only, and be in full flower before them.

*Calceolarias*.—Strong healthy plants in 5-inch pots that are moderately full of roots may be placed into others 2 and 3 inches larger. The whole stock of these may be potted on from time to time as they need more root room. Do not allow them to become root-bound before this operation is done, or they will be thrown prematurely into flower. Keep these plants perfectly cool and standing upon a moist base.

*Bouvardias*.—Plants that flowered early and have been kept dry to ripen and harden them will have roots in capital condition for cutting into short lengths for next year's stock of plants. Two or three portions of root may be placed in the centre of each small pot. A little sand should be placed about the roots and covered with about a quarter of an inch of fine soil. When placed in pots at first they can be grown on without a check, which will result from lifting them out of pans and boxes and repotting them. Place the small pots in boxes with a little cocoa-nut fibre refuse amongst them, and stand the boxes on the surface of the plunging material in the forcing house.

## THE BEE-KEEPER.

### PRACTICAL BEE-KEEPING.—No. 26.

A good queen must at all times be maintained at the head of every stock. If the best results are desired, whatever system it is intended to follow in the management of the apiary, but especially when the bee-keeper desires to control or altogether to prevent the issue of swarms, strict attention must be paid to this essential point. There may be differences of opinion as to respective values of the several races of bees, some preferring the Ligurian or the hybrid, and others the common black, but upon the absolute necessity of retaining at the end of all stocks the best queens only of the respective races there cannot be two opinions. Upon this point at any rate there is practical unanimity. Queens are generally, but not by any means invariably, most productive, and consequently most valuable, in their second season. After that period their productive powers become gradually less, until at last they either die or are superseded. But, notwithstanding the loss of power, it might not be so imperatively necessary to replace these queens if there was not considerable danger of their death taking place in the early spring months, when the bees are left powerless to raise a fertile successor, or towards the end of April, when, unless the bee-keeper takes immediate steps to prevent the mischief by giving a young fertile queen, the

bees of the stock will raise a number of young princesses and throw off a swarm.

To prevent either of these two equally undesirable events it is a wise management to keep young queens only, except in individual instances when a bee-keeper may desire for some peculiar or particular reason to preserve an aged queen, even at the risk of loss in the following year. In some cases it is possible, and in small apiaries when possible most economical, to purchase young fertile queens at the time they are required; but unless a thorough reliance can be placed, not only upon the uprightness of the vendor, but also upon his knowledge of the essential points to be observed in queen-raising, it is only at a risk that these bought queens are utilised.

The best stocks in the apiary should alone be used for queen-raising purposes—stocks which have a good record and show little propensity to swarm. Again, not only must care in every case be taken to select the best stock for raising the queens, but equal care at least must be taken when choosing the colony in which the drones necessary for fertilising the princesses are to be reared. Stocks which, in addition to the other two points, have been proved to be good workers, and are not too irascible, should be the colonies from which to rear both queens and drones. It is, of course, not by any means easy at any time—in fact, during the height of the season practically impossible—to ensure that the selected queens and drones shall mate; but with proper care and attention a strong probability will result that we shall achieve our desire. At the end of April and in the beginning of May there are but few drones flying, except those reared in stocks especially encouraged or stimulated for the purpose. If early drones are required a stock may be induced to rear them by gentle feeding, and by placing a frame of drone comb in the centre of the brood nest. For effecting the mating of queens with selected drones we must if possible have drones and queens ready to fly in the beginning of May, and there will then be a probability, amounting almost to a certainty, that our desire will be consummated, and our efforts rewarded by success. The drones should be ready to fly at the latest during the first week in May. The sooner the queens are able to fly after that time the better will be their chance of meeting the selected drone. During the last days of April steps must, therefore, be taken to compel a stock possessing the required points to produce queens. This is done by removing the queen from the stock selected, and shaving the bottom edge of a comb containing worker eggs. Queen cells will then be raised in varying numbers, and a stock must be prepared to receive each one which it is desired to preserve by the time when they become sufficiently ripe for removal. In eight days—sometimes a day more or less—the bee-keeper must form his nuclei, which are small stocks used for queen-raising purposes. Nuclei are formed by removing two or three combs from a strong stock with the adhering bees, but not the queen. The adhering bees will not in many cases, however, be sufficient, and therefore the bees from a few more combs must also be added. The reason is, that the old bees will at once return to their old stand, the young alone remaining in the nucleus. One of the combs of the nucleus should contain brood in various stages, and the other honey and pollen.

The space caused in the stock by abstracting these combs must be filled up with empty combs. The frames which are to form the nucleus must be placed in a hive and closed up with dividers, and warmly covered when the

operation thus far is complete. The nucleus is, in fact, ready to receive a ripe queen cell. The stock containing the royal cells must now be opened, and a cell cut out, taking the greatest care not to shake or bruise the royal cot, and also cutting out with it an inch of the adjoining comb. This cell must now be placed head downwards between the combs of the nucleus, and kept in position by a pin stuck through the spare piece of comb cut out for the purpose. The nucleus must now be kept warm, and a little feeding done if necessary. In the course of a few days the princess will emerge; shortly after that will meet the drone, and, unless some accident happens, become fertile. She must then either be removed to a strong stock or extra combs must be added to the nucleus, which will thus be gradually built up into a strong stock, and in reality form a swarm. Care must be taken not to allow the queen cells to suffer a chill during removal, and extreme caution is necessary when excising them from the comb to which they depend. This method may be adopted at any time when the weather is fit for the flight of queens and drones, and no difficulty need be apprehended in carrying it out.

Introducing the queens to stocks will receive attention in a following article, but at present it may not be unwise to again call the attention of bee-keepers to the value of co-operation in this as in many other matters connected with the management of the apiary. If one bee-keeper gives up a stock for drone-raising, and a neighbour gives up a stock for queen-rearing, both will receive a benefit, and both will have the advantage of the trouble and expense being divided. Many bee-keepers naturally object to devoting their best stock to raising a few queens. In small apiaries it is certainly only at a considerable loss that queens are raised, because possibly only three or four are required, and the remainder must be destroyed unless they can be sold or exchanged, and this is in most districts rarely possible. It is preferable in such cases to purchase the queens if they can be obtained from reliable men at fair prices; but it is no economy to give a low price, and receive a diseased or comparatively worthless queen. It is far better on the whole for a few small bee-keepers to club together and agree to divide the expense of queen raising between them rather than to trust to strangers. The best stocks must always be chosen for the purpose, and if early drones are required, the greatest possible care must be taken to feed the stock regularly, otherwise the larvæ will be certainly destroyed, and the hope of the bee-keeper frustrated.

Many experienced men prefer to re-queen all their stocks in autumn, and provided the queens are not reared too early the princesses will mate with the selected drone, because the other drones will in all normal cases be killed at the end of the honey season. Such queens are good unless accidentally killed or maimed for two seasons, except when hives of large size are used, and the productive powers of the queen are consequently taxed to the utmost. As such large hives should always be used in our opinion, if profit is the object of the management of bees, it will be necessary to have a fresh supply of queens every year, but when small hives are used a queen which in a large hive would be comparatively worthless, will in a small hive with a circumscribed brood nest be equally as valuable as a younger and more fertile mother. Each one must act in the manner best calculated to effect his object. It is sufficient to have pointed out the means by which queens may be successfully reared, and as it were compelled to mate with selected drones.—FELIX.

## BEEES WEARING OUT AT THE HEATHER RIPENING HONEY.

WHEN I began to read "A Lanarkshire Bee-keeper's" contribution on page 503, taking me to task for misquoting him, I really felt surprised. Surely, I thought, my memory has not been playing me a trick, and led me to ascribe to him what had been said by someone else. I always read his articles with great care—firstly, to get all the information I can, for I have an idea he was a veteran bee-keeper before I was born, and is a thorough master of his subject. Secondly, to see or get hints on points that are still unsolved, for he has such a happy knack of stating them, which makes his articles so interesting. Therefore I determined at once I would find the quotation, but before I reach to the end of the paragraph he says, "I have witnessed hives at the moors having nearly all their bees lost, but not by working on the Heather, but by some occult influence of Heather or season which I cannot explain." Here we have it; he has seen strong hives dwindle down to nuclei on the moors, and he cannot explain the cause. I do explain it; I say it is caused by bees being tempted to leave their hives through the smell of the Heather and getting chilled before they could return. To prevent it I place the hives a mile off the Heather. I did not imply, or intend to imply, that he had said Heather had a weakening influence on bees individually. I meant that strong stocks dwindled down to weak ones, as the context of my contributions will show. I also tried to show that when hives were located a mile away off Heather, nuclei rapidly increased into full stocks, while full stocks appeared to lose none of their population, owing to the fact that when working on the Heather bees are not worn to death so much in flying from blossom to blossom.

He does not appear to have ever made any experiments on the point; probably I never should have suspected the real cause had I not had the *entrée* of almost every apiary in my district, and as I keep my eyes open I quickly suspected it. Then curiously enough, the only experiment made by others he quotes goes in favour of my theory, that a mile away is the proper location. Then I see "Mid-Lothian" comes forward to say his bees have always done best when placed a mile off. Now, while I assert most positively that one mile off the Heather with 300 to 600 feet rise is the proper place to fix them, I do not wish to say or imply that they will do so equally well five miles off, or why am I annually at the trouble and expense of moving my bees four miles nearer? I simply said that in fine settled weather bees would work well at five miles distance, yet I know they will not attempt the journey if there is a risk of being caught in a storm. I made this assertion and gave my facts to prove it to refute a statement made in another Journal that bees would starve with good pasture two miles off. Then, again, while I fix on one mile as being the best, I do not think the extra advantage will pay for the trouble and expense of moving bees if they stand within three miles off.

Our friend speaks of bees working in different places at different times of the day: for instance, they would be working on one patch in morning, and another in the afternoon, the afternoon patch being always deserted in the morning, and *vice versa*. I once propounded the theory that "the honey flow depended on the amount of sunshine, and not on the amount of flowers"—*i.e.*, no sun no honey, much sun much honey, and I was well laughed at. This was several years ago, and yet I still assert this theory to be true, though it did not seem to work during the past droughty summer, the fact being the earth was devoid of moisture to help the sap to flow. The last spring I noticed a fine bed of *Arabis alba* in full bloom, where the sun could not shine upon it until 3 P.M., then it came between two houses, in the form of a narrow ribbon-like beam. The interesting point was to see it totally neglected by the bees till the sun reached it, then they only worked on the narrow strip it shone on, moving as it moved. I venture to assert therefore that where the bees did not work no sunshine fell.

The other point he differs from me about is the Pettigrew theory of bees re-swallowing their honey to evaporate it, and implies that because bees store ripe honey in the new comb they first make in an empty hive, they could not re-swallow it, and therefore the theory is untenable. I do not see it in this way. When bees have empty cells they first deposit their honey in those cells and ripen it afterwards, and acting on that theory I have for several years always extracted my honey the first thing in the morning before the bees began working, and I have yet to see the first crude honey thrown out; it is while still warm run through muslin and bottled, and always sets as hard as a brick. The wet empty combs set the bees in a rage for gathering more honey, and with the day before them and plenty of sun they not unfrequently refill their combs with ripe honey for extracting next morning. I once extracted the same combs filled with ripe honey three mornings in succession.

Now does it not occur to our friend's mind that when bees have no comb they keep the honey in their sacs until some have evaporated theirs into wax and built comb for them to store it in? The instance he gives does not in my opinion prove Pettigrew wrong, it only shows that bees can adapt themselves to altered circumstances. Those who disbelieve Pettigrew had better first get over these two facts—*viz.*, crude, thin, unripe, watery honey is always found in the combs in the evening of the day honey has been gathered; while next morning, that is before any bees begin working, every bit is quite ripe. If bee-keepers will only get up and take the day by the forelock they will never require such inventions as "honey ripeners," *i.e.*, spoilers. I should think the authors of some of them must lie in bed until the cool of the evening. There is one with quite a maze of zigzag passages and hot-water arrangements.—A HALLAMSHIRE BEE-KEEPER.

## TRADE CATALOGUES RECEIVED.

Alexander E. Campbell, Cove Gardens, Gourcock, N.B.—*Catalogue of Choice Hybrid Gladioli.*

H. Canuell & Sons, Swanley, Kent.—*Catalogues of Kitchen Garden and Flower Seeds and Chrysanthemums, 1888.*

Chr. Lorenz, Erfurt.—*Illustrated Catalogue for 1888.*

Waite, Nash & Co., 79, Southwark Street, London, S.E.—*Wholesale Price Current, 1887 and 1888.*

William Barron & Son, Elvaston Nurseries, Barrowash, near Derby.—*Catalogue of Ornamental Plants, 1888-9.*

Dicksou, Brown, & Tait, 43 and 45, Corporation Street, Manchester.—*Catalogue of Vegetable and Flower Seeds, 1888.*

Dickson & Robinson, 12, Old Millgate, Manchester.—*Catalogue of Vegetable and Flower Seeds, 1888.*



All correspondence should be directed either to "THE EDITOR" or to "THE PUBLISHER." Letters addressed to Dr. Hogg or members of the staff often remain unopened unavoidably. We request that no one will write privately to any of our correspondents, as doing so subjects them to unjustifiable trouble and expense.

Correspondents should not mix up on the same sheet questions relating to Gardening and those on Bee subjects, and should never send more than two or three questions at once. All articles intended for insertion should be written on one side of the paper only. We cannot reply to questions through the post, and we do not undertake to return rejected communications.

**Chrysanthemums (A. B.).**—The sport from Sultan at first sight is suggestive of Mr. Garner, a new imported Japanese variety; but on closer examination it is found to resemble *Agréments de la Nature* more nearly. It is certainly worthy of preservation. Grow it well another season, and send blooms to the Royal Horticultural or National Chrysanthemum Societies' Floral Committees. Both sports and seedlings require to be thoroughly tested for at least two seasons before their merit can be determined. The other we do not think is *Cullingfordi*, but the bloom is too small and undeveloped to enable us to recognise the variety.

**Thomson's Manure (E. E.).**—It is excellent for every description of crop, and for Vines is best applied as a surface dressing about three times during the season of growth—*i.e.*, when the Vines are swelling their buds, when the Grapes have been thinned, and again as soon as the fruit changes colour. If given prior to a good watering, if such be necessary, its fertilising properties will be washed into the soil; but if not watered in scratch over the surface with a fork or a rough rake, so as to mix it with the soil immediately after its application. Two or three ounces per square yard is a proper quantity to apply.

**Snow on Plants (F. Webb).**—It is quite true that some plants, "such as Pinks and Pansies," may be "flattened and broken by melting snow," but as a rule we suspect much more damage would be done by clearing the snow from them, as, apart from the risk of the plants being broken by the workman, there is the possibility of their exposure to a severe and protracted frost, and in that way sustaining serious damage. We shake the snow off such trees as are obviously almost certain to be smashed when it melts, and its removal should be done promptly while it is in a light dry state. If you sweep the snow from a portion of a lawn and severe frost follows and is long continued, the superior condition of the grass that remained under the snow will be apparent when the thaw comes, showing conclusively the effectiveness of Nature's protector.

**Wallflowers (Mrs. Makin).**—It does not follow that the disappointment you experienced last spring will have to be "endured over again" through your plants being killed this winter, though at the same time it is impossible to suggest any method for keeping them alive in the beds or borders that would be effectual in your case. Only in one year out of ten were these plants killed in a garden 200 miles north of London, their endurance of frost being the consequence of their hardness through the method of culture adopted. The seed was sown very thinly in the open garden in May, so thinly that the seedlings did not touch each other till an inch or two high, and they were transplanted 18 inches apart in the hardest and poorest ground and the most exposed position that could be found. They there grew slowly but sturdily, producing woody stems with foliage resting on the ground, and were planted in October, or soon enough to produce fresh roots, and thus become established before winter. If grown thickly together, or in rich soil in the summer, or transplanted too late to form fresh roots before winter, the plants are almost certain to succumb during severe weather. They may often be seen in open fields where they are grown for producing flowers for the London market, practically uninjured by the winter, while in gardens where the plants, through their tender-bringing up, are killed.

**Rosemary (A. Allen).**—There are three varieties—the green, golden-striped, and silver-striped. The first is in general cultivation. It thrives

best on a poor, light soil mixed with old mortar or other calcareous matters. In such, or when the plants are self-raised on an old wall, they will bear our severest winters; but in a rich soil they lose much of their aromatic nature, and perish in frost. For the green variety the situation may be open; but the other two, being tender, require to be planted beneath a south wall, or in pots, to be sheltered in winter. Propagation is by cuttings and rooted slips during any of the spring months, or by layers in the summer; but the finest plants are raised by seed. By layers is the best mode of propagating the gold and silver-striped varieties. Sow in March, or early in April, in drills half an inch deep and 6 inches apart. The rooted slips, and the cuttings of the young shoots, must be from 5 to 7 inches long, and planted in a shady border, in rows 8 or 10 inches apart, previously removing the leaves from the lower two-thirds of their length. Layers may be formed by cutting young branches half through on their under side, and pegging them down an inch or two below the surface; they become established plants by autumn. Water must be applied abundantly at the time of planting, and occasionally afterwards until established.

**Making a Hotbed (Amateur).**—Perhaps the following particulars will suffice, but if you have had little or no experience in raising Cucumbers, the earlier you commence the more likely you will be to fail. In preparing the manure we will commence with it fresh at the stable door. The first thing is to throw it into a close body to "sweat." Shake it over loosely and reject a portion of the mere droppings, for these take the most purifying, and, moreover, engender an overpowerful and sometimes unmanageable heat. The main bulk of the material thus thrown together will in a week or so become exceedingly hot, and must then be turned completely inside out, and in so doing every lock or patch which adheres together must be divided. Sprinkle with water now regularly as the work proceeds, rendering every portion equally moist. After the mass has lain for about four days longer give a liberal amount of water on the top. This will wash out at the bottom of the heap much of its gross impurities. In a few more days it must be again turned inside out, using water if dry in any portion, and after laying nearly a week it should be almost fit for use; but it is well to give it even another turn. If any tree-leaves or strawy materials are to be added to the mass they may be so at the last turning but one. The heap ought now to be "sweet;" a handful drawn from the very interior and applied to the nostrils will not only be devoid of impure smell, but will actually possess a somewhat agreeable scent, similar to the smell of Mushrooms. Select a spot perfectly dry beneath, or rendered so, exposed to a whole day's sun; but the more it is sheltered sideways the better, as, starved winds, by suddenly lowering the temperature, cause a great waste of material as well as of labour. Some portable screens, therefore, are useful things for early work. The ground surface should be nearly level. It is well also to fill most of the interior of the bed after building it half a yard in height with any half-decayed materials, such as half-worn linings, fresh leaves, &c. This will in general secure it from the danger of burning, whilst it will also add to the permanency of the bed, for the Cucumber roots will descend and thus secure an indefinite amount of food during the hot weather of summer. A bed should be at least 4 feet high at the back, if 5 feet all the better; and as soon as built let some littery manure be placed round the sides in order to prevent the wind searching it. As soon as the heat is well up, or in about four days from the building of it, the whole bed should have a thorough watering. It is now well to close it until the heat is well up again, when a second and lighter watering may be applied, and it will be ready for the hills of soil.

**Cottagers, Amateurs, and Garden Labourers Exhibiting (E. J.).**—Yours is the second letter we have received on this subject, and our reply will suffice for both inquirers. The difficulty appears to be as to the classes in which regular workmen in gentlemen's gardens should be allowed to compete at local shows. Agricultural labourers and other occupants of small cottages feel themselves handicapped if regular workmen in gardens enter the lists against them, the "garden men" thereby securing most of the chief prizes. It is undoubtedly desirable in public exhibitions that the competitors be as near as is practicable placed on equal terms. In respect to the two sections indicated there cannot be equality, because if a man has worked in a good garden for a number of years he has served an apprenticeship as a kitchen gardener and can raise plants, grow them, and time the crops for a given date as well as a professional gardener can, and better than some of them. Further, workers in gardens have facilities for procuring surplus plants and choice varieties that agricultural labourers cannot obtain, these latter thus being placed at a disadvantage in two important aspects. Then "amateurs," which for the purpose in question may consist of persons who employ men for digging, trenching, manning, and other heavy work, the employers practically growing and attending to their own crops—these persons who may be well-to-do shopkeepers, farmers, and professional men, object also to compete with the "garden men," because their professional experience and other advantages, real or supposed, place them beyond the pale of "amateurs." It is not easy to arrive at a decision in such cases that will give general satisfaction, and probably impossible that any one decision can be applicable to all. In districts where men regularly employed in gardens are numerous and funds adequate, prizes are provided for those men, and a conflict of classes is avoided. But such cases are exceptional. In one Society garden labourers were allowed to compete with cottagers on signing a declaration that no plants, seeds, roots, or produce were obtained from the gardens in which they worked, the breaking of such engagement resulting in disqualification to exhibit at any future shows. The plan answered very well, but the committee of another local horticultural society had to pass a rule excluding regular workmen in gardens from competing in either the cottagers' and amateurs' classes; indeed, they were entirely debarred from showing for prizes. Before this stringent rule was adopted there was nothing but disquietude, and the existence of the society was jeopardised, but afterwards it flourished and flourishes still. It is necessary that the circumstances attendant on each case be considered in seeking a right solution in this perplexing matter.

**Names of Plants.**—We only undertake to name species of plants, not varieties that have originated from seed and termed florists' flowers. Flowering specimens are necessary of flowering plants, and Fern fronds



should bear spores. Specimens should arrive in a fresh state in firm boxes. Slightly damp moss or soft green leaves form the best packing, dry cotton wool the worst. Not more than six specimens can be named at once. (B. R. M.).—1, *Erica gracilis autumnalis*; 2, *Erica hyemalis*; 3, *Helleborus niger maximus*; 4, A dried flower of *Trichinium Manglesi*. (S. W.).—1, *Davallia dissecta*; 2, *Davallia Mooreana*; 3, *Davallia parvula*. (J. R. H.).—1, A good variety of *Epiphyllum truncatum*; 2, *Asplenium Adiantum-nigrum*.

COVENT GARDEN MARKET.—DECEMBER 28TH.

A FAIR business has been done on the whole during Christmas week, but prices have been unchanged.

FRUIT.

	s. d.	s. d.		s. d.	s. d.
Apples, 1/2 sieve .. ..	1	6 to 3	6	Oranges, per 100 .. ..	4 0 to 8 0
Nova Scotia and				Pears, dozen .. ..	1 0 1 6
Canada barrel 10 0	18 0			Pine Apples, English,	
Cebs, 100 lbs. .. ..	55 0	0 0		per lb. .. ..	1 6 2 0
Grapes, per lb. .. ..	1 0	3 0		St. Michael Pine, each	3 0 5 0
Lemons, case .. ..	10 0	15 0			

VEGETABLES.

	s. d.	s. d.		s. d.	s. d.
Artichokes, dozen .. ..	1 0 to 2 0		Lettuce, dozen .. ..	0 9 to 0 6	
Asparagus, bundle .. ..	0 0 0 0		Mushrooms, punnet .. ..	0 6 1 0	
Beans, Kidney, per lb. ..	0 3 0 0		Mustard and Cress, punt.	0 2 0 6	
Beet, Red, dozen .. ..	1 0 2 0		Onions, bunch .. ..	0 3 0 0	
Broccoli, bundle .. ..	0 0 0 0		Parsley, dozen bunches ..	3 0 3 0	
Brussels Sprouts, 1/2 sieve	3 6 4 0		Parsnips, dozen .. ..	1 0 0 0	
Cabbage, dozen .. ..	1 6 0 0		Potatoes, per cwt. .. ..	4 0 5 0	
Capiciums, per 100 .. ..	1 6 2 0		"    Kidney, per cwt.	4 0 0 0	
Carrots, bunch .. ..	0 4 0 0		Rhubarb, bundle .. ..	0 2 0 0	
Caniflowers, dozen .. ..	3 0 4 0		Salsafy, bundle .. ..	1 0 1 6	
Celery, bundle .. ..	1 6 2 0		Scorzoneria, handle .. ..	1 6 0 0	
Coleworts, doz. bunches	2 0 4 0		Seakale, basket .. ..	1 0 1 3	
Cucumbers, each .. ..	0 4 0 6		Shallots, per lb. .. ..	0 3 0 0	
Endive, dozen .. ..	1 0 2 0		Spinach, bushel .. ..	1 6 2 0	
Herbs, bunch .. ..	0 3 0 0		Tomatoes, per lb. .. ..	0 4 0 6	
Leeks, bunch .. ..	0 3 0 4		Turnips, bunch .. ..	0 4 0 6	

PLANTS IN POTS.

	s. d.	s. d.		s. d.	s. d.
Aralia Sieboldi, dozen ..	8 0 to 12 0		Fuchsia, dozen .. ..	0 0 to 0 0	
Arbor vite (golden) dozen	6 0 9 0		Hyacinths, (dozen) .. ..	9 0 12 0	
"    (common), dozen ..	0 0 0 0		"    (Roman), doz. .. ..	9 0 10 0	
Asters, dozen pots .. ..	0 0 0 0		Hydrangea, dozen .. ..	0 0 0 0	
Azalea, dozen .. ..	30 0 42 0		Lilies Valley, dozen .. ..	18 0 24 0	
Begonias, dozen .. ..	4 0 9 0		Lilium lancifolium, doz.	0 0 0 0	
Capiciums, dozen .. ..	0 0 0 0		"    longiflorum, doz.	0 0 0 0	
Chrysanthemums, dozen	9 0 18 0		Marguerite Daisy, dozen	6 0 12 0	
Cineraria, dozen .. ..	0 0 0 0		Mignonette, dozen .. ..	0 0 0 0	
Dracena terminalis, doz.	30 0 60 0		Musk, dozen .. ..	0 0 0 0	
"    viridis, dozen ..	12 0 24 0		Myrtles, dozen .. ..	6 0 12 0	
Erica, various, dozen ..	9 0 18 0		Palms, in var., each ..	2 6 21 0	
Enonymus, in var., dozen	6 0 15 0		Pelargoniums, dozen ..	0 0 0 0	
Evergreens, in var., dozen	6 0 24 0		"    scarlet, doz. ..	3 0 9 0	
Ferns, in variety, dozen	4 0 18 0		Poinsettia, dozen .. ..	12 0 15 0	
Ficus elastica, each ..	1 6 7 0		Solanum, dozen .. ..	9 0 12 0	
Foliage Plants, var., each	2 0 10 0		Tulips, dozen pots .. ..	6 0 9 0	

CUT FLOWERS.

	s. d.	s. d.		s. d.	s. d.
Abutilons, 12 bunches ..	3 0 to 6 0		Lilies, White, 12 bunches	0 0 to 0 0	
Anemones, 12 bunches ..	0 0 0 0		"    Orange, 12 bunches	0 0 0 0	
Arm Lilies, 12 blooms ..	5 0 8 0		Lily of the Valley, 12		
Asters, 12 bunches .. ..	0 0 0 0		"    sprays .. ..	1 0 2 0	
"    French, bunch ..	0 0 0 0		Marguerites, 12 bunches	2 0 6 0	
Azalea, 12 sprays .. ..	1 0 1 6		Mignonette, 12 bunches	3 0 6 0	
Bonvardias, bunch .. ..	0 6 1 0		Narciss, white (French) 12		
Camellias, 12 blooms ..	3 0 4 0		"    bunches .. ..	6 0 10 0	
Carnations, 12 blooms ..	1 0 2 0		Pelargoniums, 12 trusses	1 0 1 6	
"    12 bunches .. ..	0 0 0 0		"    scarlet, 12 trusses	0 6 0 9	
Chrysanthemums, 12 bchs.	9 0 18 0		Poinsettia, 12 blooms ..	6 0 8 0	
"    12 blooms .. ..	2 0 4 0		Primula (single), bunch ..	0 6 0 0	
Dahlia, 12 bunches .. ..	0 0 0 0		"    (double), bunch ..	0 9 1 6	
Daisies, 12 bunches ..	2 0 4 0		Polyanthus, 12 bunches ..	0 0 0 0	
Encharis, dozen .. ..	4 0 6 0		Ranunculus, 12 bunches	0 0 0 0	
Gardenias, 12 blooms ..	6 0 9 0		Roses, 12 bunches .. ..	0 0 0 0	
Gladiolus, 12 sprays ..	0 0 0 0		"    (indoor), dozen ..	2 0 3 0	
Hyacinths, Roman, 12			"    Tea, dozen .. ..	1 6 3 0	
"    sprays .. ..	0 6 1 0		"    red, dozen (French)	1 6 3 0	
Iris, 12 bunches .. ..	0 0 0 0		"    yellow .. ..	3 0 6 0	
Lapageria, white, 12			Stephanotis, 12 sprays ..	0 0 0 0	
"    blooms .. ..	2 0 3 0		Tropeolum, 12 bunches	2 0 3 0	
Lapageria, coloured, 12			Tuberose, 12 blooms ..	1 0 1 6	
"    blooms .. ..	1 0 1 6		Tulips, dozen blooms ..	1 0 2 0	
Lilium longiflorum, 12			Violets, 12 bunches ..	1 0 1 6	
"    blooms .. ..	6 0 9 0		"    (French), bunch 1 3	2 0	
Lilium lancifolium, 12			"    (France), bunch 3 0	5 0	
"    blooms .. ..	0 0 0 0		White Lilac, per bunch ..	6 0 7	

expression while seeing the wonderful show of animals and implements held recently in the Agricultural Hall, Islington. Certainly no sign of depression was visible there; on the contrary, ample evidence of progress and improvement met our eyes on every side. The show has been pronounced by a competent judge to be the best of its kind ever held in the world. However this may be, it was of undoubted excellence in every section, but more especially so among the cattle, where we were glad to find a falling off in mere size and excess of fat, that extravagant class of animal having clearly given place to symmetrical beasts, plump enough for all practical purposes.

Early maturity was probably never better exemplified, and that, too, in almost every class; and proof was shown that it is possible for an animal of about twenty months to increase in weight at a rate of almost 2½ lbs. daily. This was best seen among the Herefords, Sussex, and Shorthorns, but all classes were good, each containing many superior animals, with the exception of polled Suffolks, which we regret to say was a weak class, and yet we know it to be quite one of the best and most useful, both for beef and dairy cattle. Suffolk farmers, with those of Norfolk and Essex, have probably felt the severity of the depression more keenly than it has been felt elsewhere, and it was hardly to be expected that they would be able to send many contributions to the great metropolitan show. Nor is mere prize-winning to be regarded as a sure sign of prosperity. We know it is not, and could point to a prominent prizewinner at the show who has had several thousand acres of land thrown upon his hands, and whom we had met only a few days previously at a great county meeting to pass motions of appeal for help to the government in our need.

At our local show there were considerable numbers of bullocks, sheep, and pigs, all which were sold by auction on the following day. The head of the principal firm of auctioneers had to express regret at a falling off in numbers among the cattle, his number for sale being less by seventy than it was last Christmas. He also said that during the last few months he had sold many beasts at only a fraction over 5d. per lb., and he knew that it could not answer to fatten, or even graze beasts at so low a price. But it must answer the purpose of the Islington prizewinners to sell at the fancy prices at which so many of them are able to dispose of their Christmas beasts, to say nothing of the value of the reputation so gained, and which would lead to many a subsequent profitable sale of young stock. It was a knowledge of this fact which induced a contemporary to declare the Islington show one huge advertisement, and undoubtedly it was very much so, but we should hardly suppose Her Majesty's thirteen prizes would be turned to account for trade purposes.

The fattening of sheep for such shows appears to be carried to as ridiculous an extreme as that of cattle was formerly. The Marquis of Bristol's first prize pen of magnificent Suffolk sheep were sold for £7 a-piece, yet they would probably prove more profitable as an advertisement to the butcher who purchased them than they did to the noble breeder of them, for the development of such huge masses of fat is a costly process, which after all answers no sound practical purpose. We require early maturity in sheep even more than in cattle, but we do not require them to be forced into an abnormal condition of fatness. The champion prize went to a pen of wonderful Oxfordshire wethers, but we question if such a prize may be taken for the guidance of stockmasters,



CHRISTMAS CATTLE.

CAN such a thing as agricultural depression be possible? was the question to which we gave involuntary

Oxford men were, of course, perfectly certain of the soundness of a decision which gives the post of honour to the sheep of their county. We are certainly of opinion that for champion prizes to be really useful they should only embrace special classes, and among sheep the Downs and Longwools ought certainly to be kept separate in such a competition. We have had practical experience of the high value of judicious cross-breeding among all animals of the farm, and we should much like to see special recognition of really useful classes of cross-breeds.

Practical utility before fancy, say we, and that principle should be the leading one at our cattle shows. It is undoubtedly gaining ground, for hard times have led to the practice of rigid economy even in breeding of prize animals. Does it pay? is the question which every cattle breeder has to ask himself now, and the answer is not unfrequently the reverse of satisfactory. Feeding stuffs are all very cheap now, and so long as they are nutritious we hold with a liberal use of them in the right way. This is to feed well from the outset, and never to suffer any animal kept for profit to fall off in condition, for that means a loss of money in the end. Early maturity is now a certainty if only the animal be both well bred and well fed.

WORK ON THE HOME FARM.

Hardly any of what may be termed extra winter work is now done upon many farms, for as soon as harvest work is ended there is a reduction of labour, extra hands being easily available for corn-threshing. The sound of the flails on the barn floor is now almost entirely a thing of the past, yet we do know one worthy yeoman farmer who keeps his barns filled with corn sheaves in reserve for winter hand-threshing. The men thresh and clean it for about 1s. 8d. per quarter, and the master says the cost is not greater than if the work was done by steam; he is thus able to retain the services of a given number of men throughout the year, and avoids taking on a number of strange hands for special work. It would be well if all seed corn, at any rate, were hand-threshed, for so little care is taken to clean out the threshing drum after each sort of corn is finished that it has really become a difficult matter to procure pure samples of seed. The great seed firms are fully aware of this, and their offers of pure seed corn command an amount of attention from farmers which in these hard times is absolutely marvellous. To give 10s. or 12s. a bushel now for seed corn would appear an absolute absurdity, yet it is done, and we are assured there is an extensive trade in such samples. We entirely agree, however, in the wisdom of growing only the best sorts of corn, but the difficulty is to know which are the best for our particular soil. It certainly does not answer to depend upon what may be termed show samples, for they are frequently the outcome of special culture that is hardly within the scope of an ordinary farmer. The really safe course to follow in the selection of seed is to buy improved samples of well-known sorts, and not hastily turn to novelties which may or may not be worth having. Giant Wheat soon becomes dwarfed in poor soil, and the yield is then altogether inferior to that of an ordinary sort. A little common sense brought to bear upon this matter will keep a man from going far wrong in it. Never let it be forgotten that our practice requires balance, and that to give an extravagant price for seed corn to be sown upon poor, wet, or foul land never answers. First of all make sure that the condition of the land is sound and fertile, and then the seed cannot be too good for it. It is as much worth while doing all we can towards good cultivation as it ever was, and it is just those farmers who have kept up the condition of the land who are best able to face hard times.

UNITS OF VALUE IN MANURE.

Morton's Almanack for Farmers and Landowners,\* is a valuable publication, many subjects of importance being treated in its pages by recognised authorities. As an example we cite the following contribution by Mr. F. J. Lloyd, F.C.S., Consulting Chemist to the British Dairy Farmers' Association, which will be interesting to many cultivators, both on the farm and in the garden:—

"The value of a manure to the farmer depends upon its ingredients and the use to which he may apply it; but the price of that manure depends upon the demand and supply of the substances containing those ingredients. Thus guano, being difficult to obtain, as the supply is becoming limited, while the demand for it does not diminish, fetches in the market a high price, and if the farmer would buy the substances contained in guano in some other forms, he might obtain them for much less than by buying them as guano. But this assumes that the sub-

\* Vinton & Co., Hampstead Road, London.

stances can be bought in other forms to possess all the qualities of those substances as present in guano. Now this has not been proved, and indeed all the evidence goes to show that phosphoric acid in one form and phosphoric acid in another form have very different values for the farmer's land and crops—that nitrogen in one form may be most valuable, in another form most useless. It will be seen, then, that in valuing manures by units very great errors may be made unless the form in which the constituents exist is known as well as their quantity. It is in his ability to estimate the form, quite as much as in estimating the quantities of the ingredients, that the value of the analyst lies.

"The principal constituents which we shall find in manures will be:—

- " Phosphoric acid as soluble phosphates, as in superphosphates.
- " Phosphoric acid as insoluble phosphates, as in mineral phosphates.
- " Phosphoric acid as precipitated or retrograde phosphates, as in precipitated phosphate.
- " Potash, as chloride and sulphate, as in kainit.
- " Nitrogen, as ammonia salts and nitrates easily soluble, as in ammonia sulphate or sodium nitrate.
- " Nitrogen as organic compounds easily decomposed, as in blood.
- " Nitrogen as organic compounds slowly decomposed, as in shoddy.

"By taking in the *Agricultural Gazette*, or any leading paper, the farmer may see the quoted prices of the compounds which contain these substances, and from these quotations he may calculate the unit values of the above constituents for that week.

"For example, we may find the quotation of superphosphate, 25 per cent. soluble, is £3 a ton. Convert the price of the manure into shillings, and divide by the per-centage of constituent present, thus:—

$$\begin{array}{r} \text{£}3 \\ 20 \\ \hline 25 \end{array} \text{ ) } 60 \text{ ( } 2\text{s. } 5\text{d.}$$

Or 2s. 5d. is the unit value of the soluble phosphate in that manure. Take as another example sulphate of ammonia, 24 per cent. of ammonia price £13 10s. per ton. Convert the price into shillings, divide by per-centage, and we have the unit value (price is the more correct term) of the ammonia.

$$\begin{array}{r} \text{£}13 \text{ } 10\text{s.} \\ 20 \\ \hline 24 \end{array} \text{ ) } 270 \text{ ( } 11\text{s. } 3\text{d.}$$

Or 11s. 3d. is the unit price of ammonia in the sulphate of ammonia, at the price quoted.

"By reversing the process we thus compute the value of a compound manure. Thus a manure is offered the same week at £6 a ton, said to contain 30 per cent. soluble phosphate and 3 per cent ammonia. If we know how the ammonia exists, and that it is present as sulphate, our calculation of the fair market price would be as follows:—

"Thirty per cent. of soluble phosphate at 2s. 5d. per unit. Multiply 2s. 5d. by 30 gives the value in shillings of the soluble phosphate.

"Again, 3 per cent. ammonia at 11s. 3d. per unit. Multiply 11s. 3d. by 3, and this gives the value of the ammonia; add the two together, and we obtain the value of the manure at the prices here assumed as quoted.

$$\begin{array}{r} \text{Thus : } \quad 2\text{s. } 5\text{d.} \times 30 = 72\text{s. } 6\text{d.} \\ \text{And } \quad 11\text{s. } 3\text{d.} \times 3 = 33\text{s. } 9\text{d.} \\ \hline 106\text{s. } 3\text{d.} \end{array}$$

or £5 6s. 3d.; therefore the manure is too dear at £6 a ton.

"Such is the method of discovering and utilising the unit values of the constituents in manure, the chief difficulty being, as before stated, to know the form in which the constituents exist."

METEOROLOGICAL OBSERVATIONS.

CAMDEN SQUARE, LONDON.

Lat. 51° 39' 40" N.; Long. 0° 8' 0" W.; Altitude, 111 feet.

DATE.	9 A.M.					IN THE DAY.				Rain
	Baromet- er at 32° and Sea Level.	Hygrome- ter.		Direction of Wind.	Temp. of soil at 1 foot.	Shade Tem- perature.		Radiation Temperature.		
		Dry.	Wet.			Max.	Min.	In sun.	On grass	
1887.										
December.										
Sunday .....	18	Inches	deg.	deg.	S.	deg.	deg.	deg.	deg.	In.
Monday .....	19	29.798	33.7	34.0	W.	39.8	43.9	34.4	55.8	0.069
Tuesday .....	20	29.536	32.6	30.2	W.	37.1	30.9	47.2	25.9	—
Wednesday ..	21	29.543	33.2	32.4	W.	38.8	36.9	28.7	38.2	0.013
Thursday .....	22	29.658	33.4	32.8	N.W.	38.2	35.9	31.2	41.1	—
Friday .....	23	29.967	32.5	32.1	N.	38.2	35.3	31.8	37.3	—
Saturday .....	24	29.989	32.0	32.0	N.W.	37.8	40.8	28.5	44.9	0.023
		29.590	33.9	33.1	N.	37.5	41.2	31.4	47.3	—
		29.769	34.2	33.1		38.7	38.4	31.0	44.7	23.9

REMARKS.

18th.—Beautiful morning, cloudy afternoon; rain 4.30 to 6 P.M., showers after.  
 19th.—Morning fine and bright, dull afternoon; drizzle after sunset.  
 20th.—Overcast, and at times damp; rain, with flakes of snow at 3.15 P.M.  
 21st.—Cloudy, but dry.  
 22nd.—Fine, but no sunshine.  
 23rd.—Slight fog early, fine and bright afterwards.  
 24th.—Rain in early morning, fine throughout; fine moonlight night.  
 A tolerably fine week, much cooler than the previous one, and rather below the average.—G. J. SYMONS.

















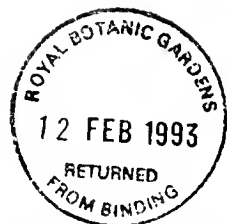

Deacidified first, last  
section edges.



