

LIBRARY OF  
THE NEW YORK BOTANICAL GARDEN

Purchased  
1915

Septemb 1899

R. W. Gibson - Inv.



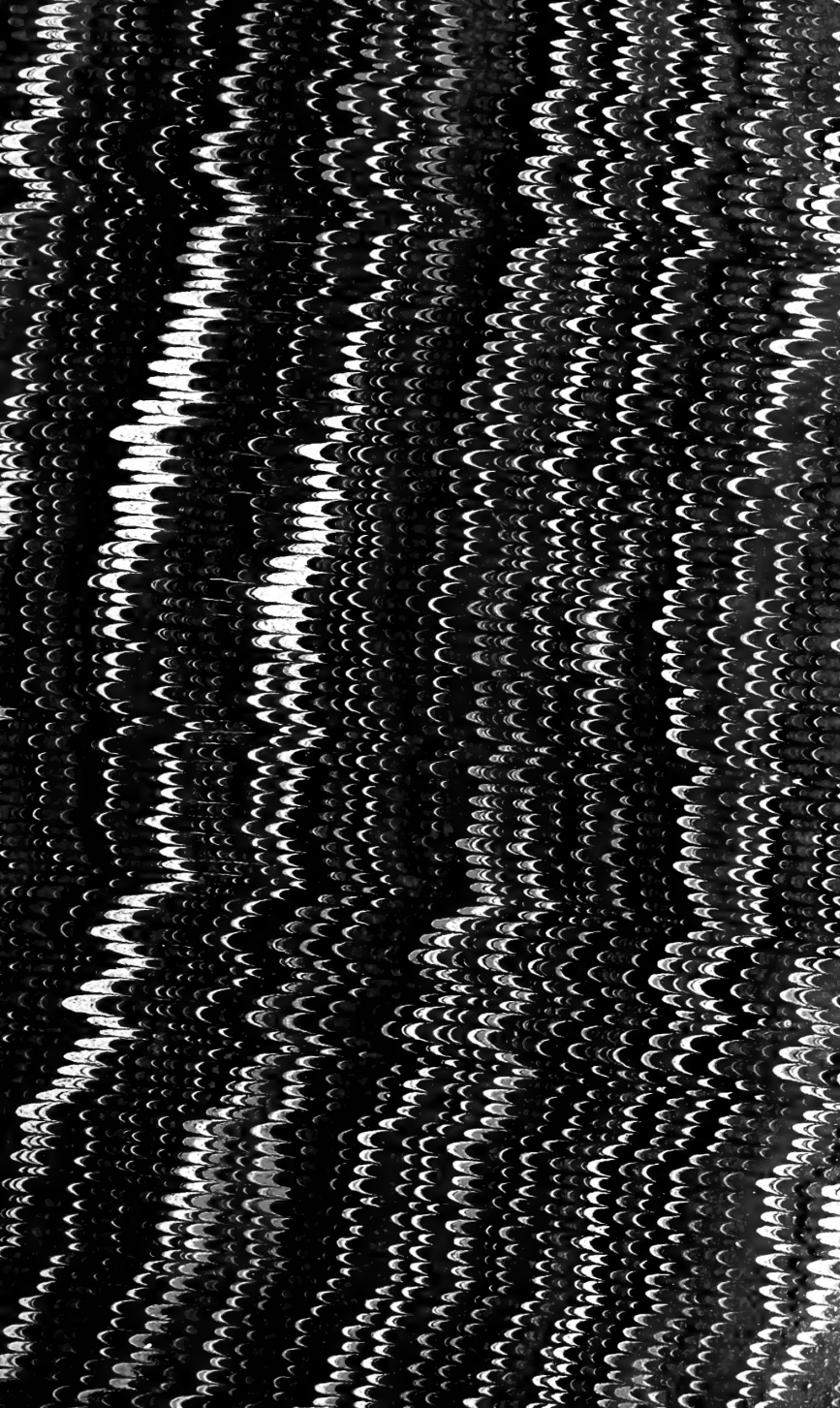



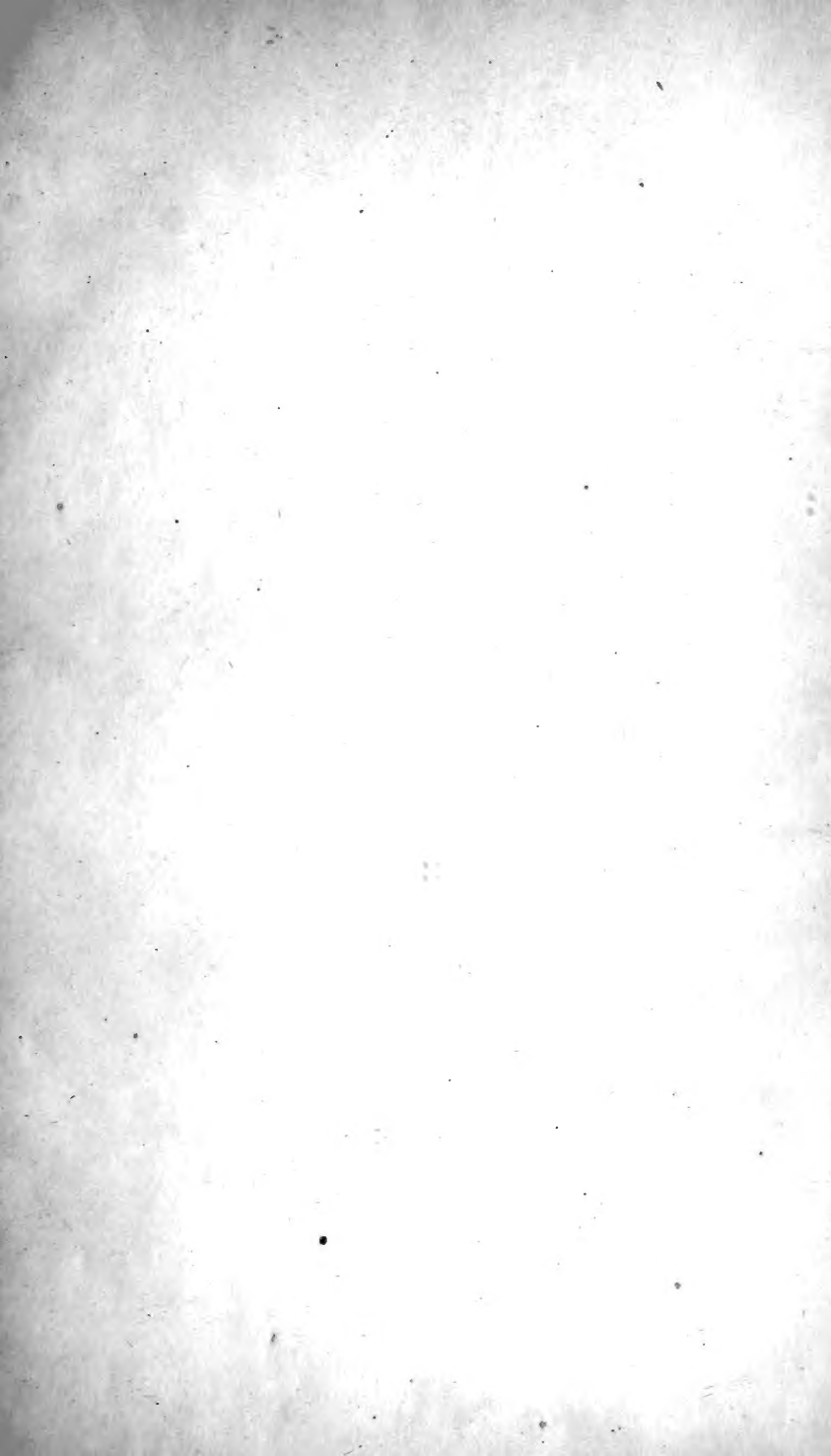



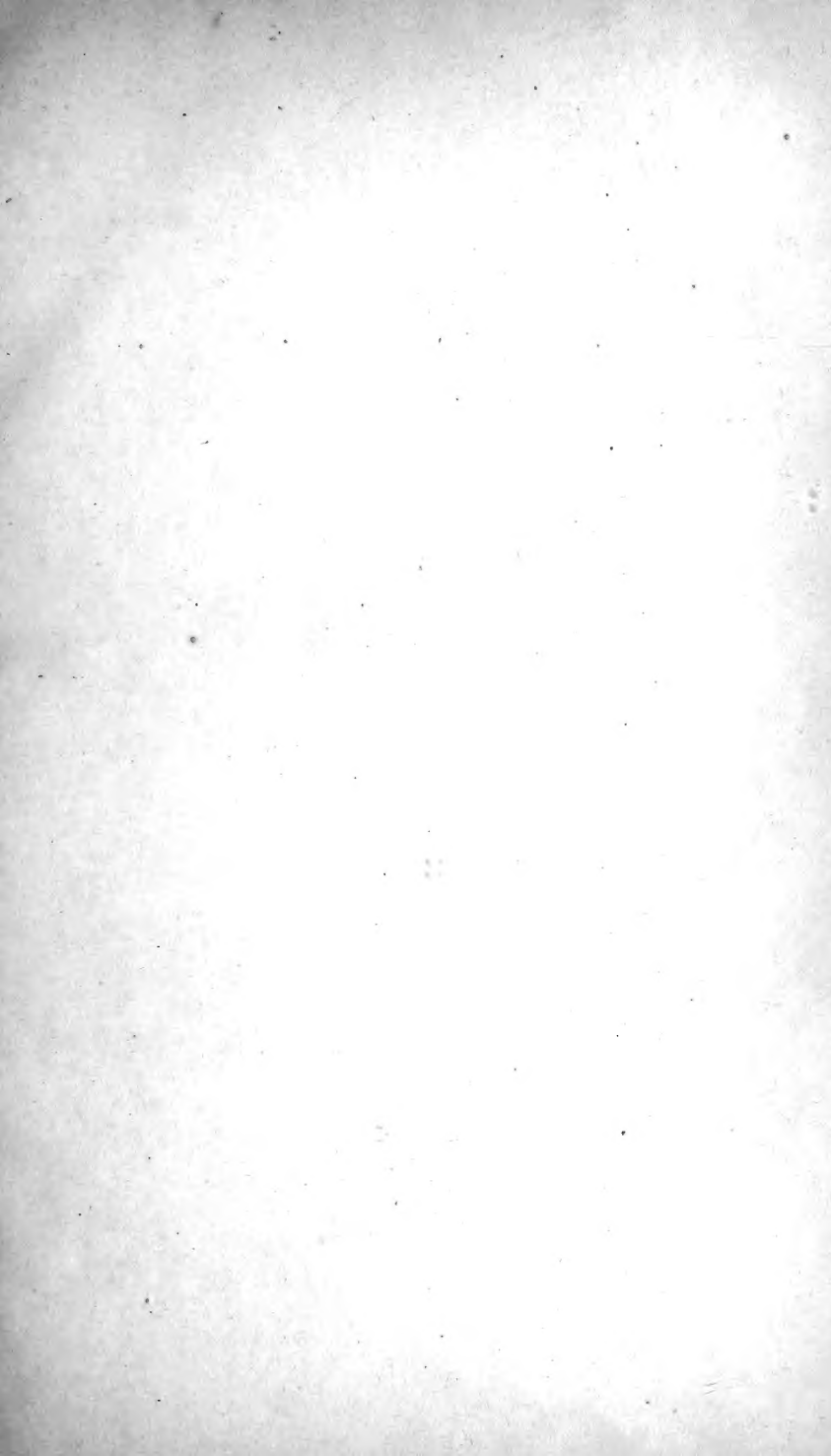



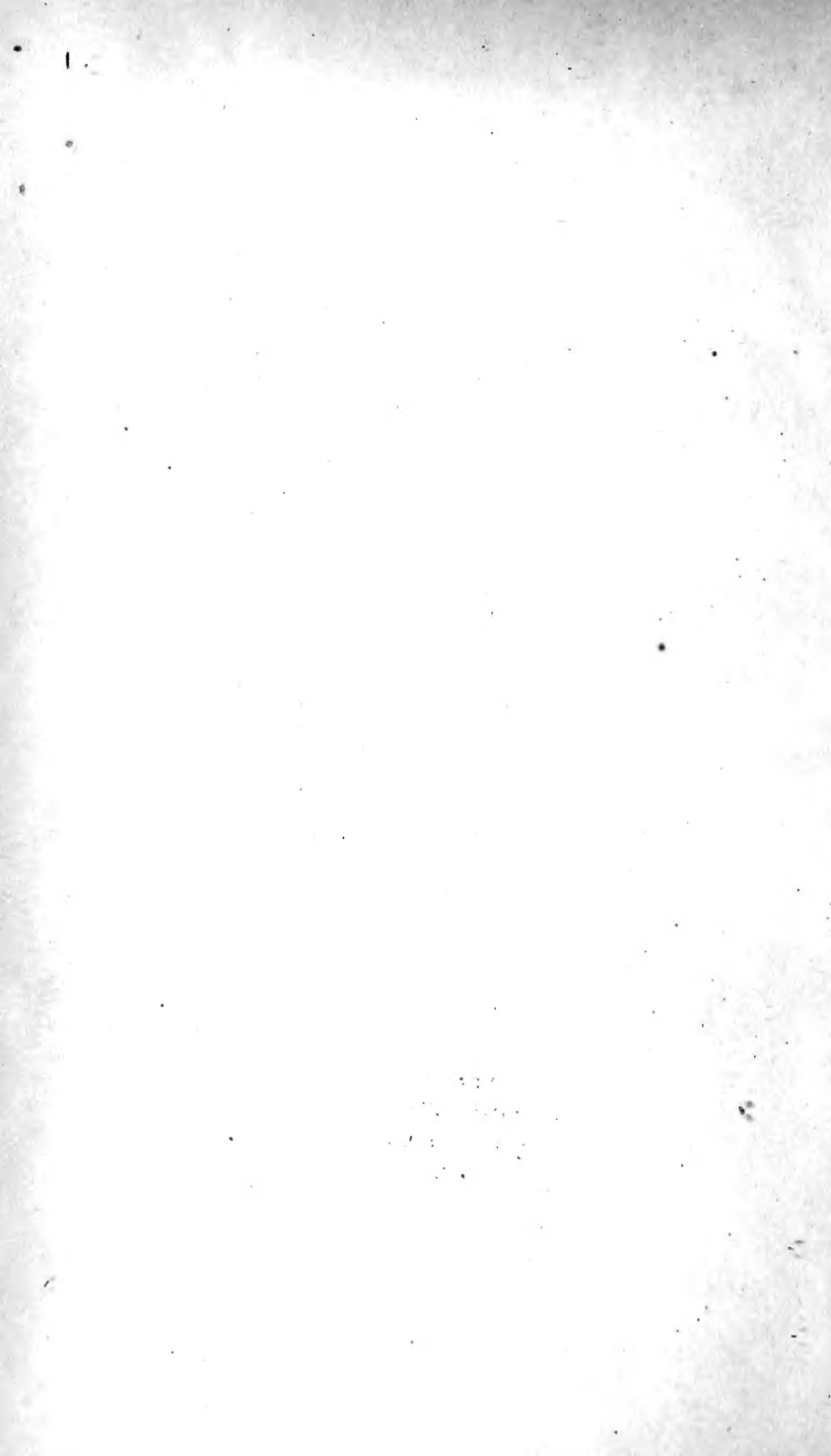

THE

JOURNAL

630  
to Pat

OF THE

ROYAL AGRICULTURAL SOCIETY

OF ENGLAND.

SECOND SERIES.

VOLUME THE EIGHTH.

---

PRACTICE WITH SCIENCE.

---

LIBRARY  
NEW YORK  
BOTANICAL  
GARDEN

LONDON:

JOHN MURRAY, ALBEMARLE STREET.

1872.

.0933  
-vol 8  
2nd series

THESE EXPERIMENTS, IT IS TRUE, ARE NOT EASY; STILL THEY ARE IN THE POWER OF EVERY THINKING HUSBANDMAN. HE WHO ACCOMPLISHES BUT ONE, OF HOWEVER LIMITED APPLICATION, AND TAKES CARE TO REPORT IT FAITHFULLY, ADVANCES THE SCIENCE, AND, CONSEQUENTLY, THE PRACTICE OF AGRICULTURE, AND ACQUIRES THEREBY A RIGHT TO THE GRATITUDE OF HIS FELLOWS, AND OF THOSE WHO COME AFTEE. TO MAKE MANY SUCH IS BEYOND THE POWER OF MOST INDIVIDUALS, AND CANNOT BE EXPECTED. THE FIRST CARE OF ALL SOCIETIES FORMED FOR THE IMPROVEMENT OF OUR SCIENCE SHOULD BE TO PREPARE THE FORMS OF SUCH EXPERIMENTS, AND TO DISTRIBUTE THE EXECUTION OF THESE AMONG THEIR MEMBERS.

VAN THAER, *Principles of Agriculture.*

# CONTENTS OF VOL. VIII.

## SECOND SERIES.

BY  
J. B. PRINGLE  
— ANNUAL  
GARDEN

STATISTICS :—	PAGE
Meteorology for the year 1871 .. .. .	1-VIII
Imports of Corn, &c., British Wheat sold, and Average Prices	IX-XIII, XVI
Acreage under each description of Crop, Fallow, and Grass ; with number of Cattle, Sheep, and Pigs in Great Britain and Ireland, 1869, 1870, and 1871 .. .. .	XIV-XV
Importations and Average Prices of certain Foreign and Colonial Productions .. .. .	XVII-XVIII
Statistics of Dairy Produce, and Prices Current .. .. .	XIX-XXIV

ARTICLE	PAGE
I.—A Review of Irish Agriculture, chiefly with Reference to the Production of Live Stock. By R. O. Pringle, Editor of 'The Irish Farmer's Gazette' .. .. .	1
II.—Method of Improving the Labouring Classes by altering the conditions of Poor Relief, and providing them with a system of Insurance through the Post Office. By the Rev. J. Y. Stratton, Rector of Ditton, Kent .. .. .	76
III.—The American Milk-Condensing Factories and Condensed Milk Manufacture. By X. A. Willard, A.M., of Herkimer, New York, Lecturer in Cornell University and in the Maine State Agricultural College; President of the New York State Dairy- men's Association and Board of Trade, &c., &c. .. .. .	103
IV.—On the Management of Grass Land, with especial Reference to the Production of Meat. By H. S. Thompson, of Kirby Hall, York .. .. .	152
V.—The Records of Contagious Cattle Diseases in Yorkshire during the Years 1870-71. By J. Dent Dent, M.P. .. .. .	180
VI.—On the Composition and Agricultural Value of Earth-Closet Manure. By Dr. Augustus Voelcker, F.R.S. .. .. .	185
VII.—Interim Report on Veterinary Investigations. By Professor J. B. Simonds .. .. .	203
VIII.—First Report of the Consulting Botanist .. .. .	211
IX.—On Straw-Blight, a Disease of Wheat Straw. By W. Carru- thers, F.R.S., F.L.S., Consulting Botanist .. .. .	213
X.—Annual Report of the Consulting Chemist for 1871 .. .. .	215
XI.—Quarterly Report of the Chemical Committee for December, 1871, with proposed forms of Guarantee to be signed by vendors of Manures and Feeding Stuffs .. .. .	223
XII.—On the Agricultural Geology of the Weald. By William Topley, F.G.S., of the Geological Survey of England and Wales. <i>With a Map</i> .. .. .	241
XIII.—On Swedish Butter Factories as adapted to Small Farm Dis- tricts. By M. Juhlin-Dannfelt, Superintendent of the Royal Agricultural College at Stockholm, and Honorary Member of the Royal Agricultural Society of England .. .. .	267
XIV.—Report on the Farm-Prize Competition of 1872. By Thomas Bowstead, Eden Hall, Penrith .. .. .	278
XV.—The French Peasant-Farmers' Seed Fund. By H. M. Jenkins, F.G.S., Honorary Secretary of the Fund. <i>With Facsimile</i> ..	325

	PAGE
XVI.—Sanitary Police and the Cattle Plague. By M. Bouley .. ..	352
XVII.—Report of the Governors of the Royal Veterinary College to the Council of the Royal Agricultural Society for the year 1871	362
XVIII.—Report on the Importation of Animals affected with Cattle- Plague during the month of July, 1872. By Professor J. B. Simonds, Principal of the Royal Veterinary College, and Con- sulting Veterinary Surgeon to the Society .. ..	367
XIX.—Report on the Exhibition of Live Stock at Cardiff. By Henry Corbet .. ..	373
XX.—Report of the Senior Steward on the Exhibition and Trials of Implements at Cardiff. By C. Wren Hoskyns, M.P., (Senior Steward) .. ..	402
XXI.—Report on the Trials of Implements at Cardiff. By C. G. Roberts, of Haslemere, Surrey .. ..	404
XXII.—Report on the Plans of Labourers' and Miners' Cottages com- peting for the Prizes offered in connection with the Cardiff Meeting .. ..	480
XXIII.—Report of the Proceedings in the Court of Exchequer in the case of Kidd <i>v.</i> the Royal Agricultural Society of England. Before Mr. Justice Blackburn and a Special Jury. Leeds Summer Assizes, August 7th, 8th, and 9th, 1872 .. ..	481

## APPENDIX.

	PAGE
List of Officers of the Royal Agricultural Society of England, 1872-3	i, xxxvii
Standing Committees for 1872 .. ..	iii, xxxix
Reports of the Council to the General Meeting, December 7, 1871, and May 22, 1872 .. ..	v, xli
Memoranda of Meetings, Payment of Subscription, &c. .. ..	xi, xciii
Distribution of Members and Council .. ..	xii, xliii
Half-yearly Cash Accounts from 1st July to 31st December, 1871, and from 1st January to 30th June, 1872 .. ..	xiv, xlvi
Yearly Cash Account, from 1st January to December 31, 1871 .. ..	xvi
Country Meeting Account, Wolverhampton, 1871 .. ..	xviii
Cardiff Meeting, 1872: Schedule of Prizes, &c. .. ..	xix
List of Stewards and Judges, and Award of Prizes at Cardiff .. ..	xlvi, l
Agricultural Education: Examination Papers, 1872 .. ..	lxxxv
Members' Chemical and Veterinary Privileges .. ..	xxxiii, xxxv, xciv, xcvi
Members' Botanical Privileges .. ..	xxxvi, xcvi

## List of Members.

## DIRECTIONS TO THE BINDER.

List of Governors and Members at the end.	PAGE
Geological Map of the Weald District .. ..	to face 241
Lithograph Facsimile .. ..	339
Tables of Results of Trials of Threshing Machines .. ..	412

The Binder is desired to collect together all the Appendix matter, with Roman numeral folios, and place it at the end of each volume of the Journal, excepting Titles and Contents, and Statistics, &c., which are in all cases to be placed at the beginning of the Volume; the lettering at the back to include a statement of the year as well as the volume; the first volume belonging to 1839-40, the second to 1841, the third to 1842, the fourth to 1843, and so on.

In Reprints of the Journal all Appendix matter and, in one instance, an Article in the body of the Journal (which at the time had become obsolete), were omitted; the Roman numeral folios, however (for convenience of reference), were reprinted without alteration in the Appendix matter retained.



## CONTENTS OF PART I., VOL. VIII.

## SECOND SERIES.

STATISTICS :—	PAGE
Meteorology for the year 1871 .. .. .	1-VIII
Imports of Corn, &c., British Wheat sold, and Average Prices	IX-XIII, XVI
Acreage under each description of Crop, Fallow, and Grass ; with number of Cattle, Sheep, and Pigs in Great Britain and Ireland, 1869, 1870, and 1871 .. .. .	XIV-XV
Importations and Average Prices of certain Foreign and Colonial Productions .. .. .	XVI-XVIII
Statistics of Dairy Produce, and Prices Current .. .. .	XIX-XXIV

ARTICLE	PAGE
I.—A Review of Irish Agriculture, chiefly with Reference to the Production of Live Stock. By R. O. Pringle, Editor of 'The Irish Farmer's Gazette' .. .. .	1
II.—Method of Improving the Labouring Classes by altering the conditions of Poor Relief, and providing them with a system of Insurance through the Post Office. By the Rev. J. Y. Stratton, Rector of Ditton, Kent .. .. .	76
III.—The American Milk-Condensing Factories and Condensed Milk Manufacture. By X. A. Willard, A.M., of Herkimer, New York. Lecturer in Cornell University and in the Maine State Agricultural College ; President of the New York State Dairy- men's Association and Board of Trade, &c., &c. .. .. .	103
IV.—On the Management of Grass Land, with especial reference to the Production of Meat. By H. S. Thompson, of Kirby Hall, York .. .. .	152
V.—The Records of Contagious Cattle Diseases in Yorkshire during the Years 1870-71. By J. Dent Dent, M.P. .. .. .	180
VI.—On the Composition and Agricultural Value of Earth-Closet Manure. By Dr. Augustus Voelcker, F.R.S. .. .. .	185
VII.—Interim Report on Veterinary Investigations. By Professor J. B. Simonds .. .. .	203
VIII.—First Report of the Consulting Botanist .. .. .	211
IX.—On Straw-Blight, a Disease of Wheat Straw. By W. Carru- thers, F.R.S., F.L.S., Consulting Botanist .. .. .	213
X.—Annual Report of the Consulting Chemist for 1871 .. .. .	215
XI.—Quarterly Report of the Chemical Committee for December, 1871 ; with proposed forms of Guarantee to be signed by vendors of Manures and Feeding Stuffs .. .. .	223

## APPENDIX.

	PAGE
List of Officers of the Royal Agricultural Society of England, 1872	i
Standing Committees for 1872 .. .. .	iii
Report of the Council to the General Meeting, December, 1871 ..	v
Memoranda of Meetings, Payment of Subscriptions, &c. .. ..	xi
Distribution of Members and Council .. .. .	xii-xiii
Half-yearly Cash Account from 1st July to 31st December, 1871 ..	xiv, xv
Yearly Cash Account from 1st January to 31st December, 1871 ..	xvi, xvii
Country Meeting Account : Wolverhampton, 1871 .. .. .	xviii
Cardiff Meeting, 1872 : Schedule of Prizes, &c. .. .. .	xix-xxxii
Members' Chemical, Veterinary, and Botanical Privileges ..	xxxiii, xxxv-vi

## List of Members.

## DIRECTIONS TO THE BINDER.

List of Governors and Members *at the end*.

The Binder is desired to collect together all the Appendix matter, with Roman numeral folios, and place it at the *end* of each volume of the Journal, excepting Titles and Contents, and Statistics, &c., which are in all cases to be placed at the *beginning* of the Volume; the lettering at the back to include a statement of the *year* as well as the *volume*; the first volume belonging to 1839-40, the second to 1841, the third to 1842, the fourth to 1843, and so on.

In Reprints of the Journal all Appendix matter and, in one instance, an Article in the body of the Journal (which at the time had become obsolete), were omitted; the Roman numeral folios, however (for convenience of reference), were reprinted without alteration in the Appendix matter retained.

METEOROLOGY ; IMPORTATIONS OF GRAIN ; SALES OF  
BRITISH WHEAT ; PRICES OF CORN AND OTHER  
PRODUCE ; AGRICULTURAL STATISTICS ; AND STA-  
TISTICS OF DAIRY PRODUCE.



[*The facts are derived chiefly from the Meteorological Reports of Mr. GLAISHER, and the Returns of the BOARD OF TRADE, and of the INSPECTOR-GENERAL OF IMPORTS AND EXPORTS.*]

---

METEOROLOGY.—1870.

*First Quarter (January, February, March).*—The exceedingly cold weather which prevailed at the end of 1870 continued until the 5th day of January, 1871, then somewhat moderated, but continued cold to the 13th. On the 19th the cold weather returned and continued to February 2nd. From the 3rd of February to the 14th of March the weather was mostly mild, and occasionally spring-like. From March 14th to the end of the quarter the weather was very changeable.

In January frost and snow stopped all out-door farm work ; the mild weather in February melted the snow, and, being accompanied by rain, caused rivers and streams to overflow, and in some cases to destroy a portion of the crops. Field work was all but stopped until towards the end of the month, vegetation was very backward, pastures and grass lands were bare, and the scarcity of fodder was severely felt. Towards the end of February, under the influence of the higher temperature, shrubs, hedges, and early fruit-trees began to bud, and early spring flowers to bloom. All kinds of vegetables were scarce.

During the month of March agricultural operations progressed vigorously ; the land was found to be unusually free from insects, and at the end of the quarter a very large breadth of land was under cultivation, but vegetation was still backward, having been checked by frequent bleak north and east winds. The corn was spoken of as healthy, but forage and vegetables were very scarce.

The mean temperature of January was  $33^{\circ}2$  or  $3^{\circ}1$  lower than the average of 100 years ; in February and March the mean temperature was  $42^{\circ}4$  and  $44^{\circ}9$  respectively, being  $3^{\circ}9$  higher in February and  $4^{\circ}0$  higher in March than the average of 100 years.

The fall of rain was 0·2 inch in excess in January and 0·5 inch in defect in both February and March.

*Second Quarter (April, May, June).*—With the exception of the period comprised between April 12th and 29th, the weather was cold throughout the quarter. The low temperature was very severe both at the beginning and at the end of June. The month of June, 1860, was of the same low temperature, but previous to that we must go back as far as the year 1821 for one of lower temperature. The deficiency for the whole quarter amounted to more than  $1\frac{1}{4}^{\circ}$  daily, from the average of 50 years, and there has been no corresponding quarter of as low a temperature at Greenwich since 1860.

The unseasonably cold weather which for the most part prevailed throughout the quarter, together with the north winds, the cloudy sky, and scanty sunshine, caused vegetation generally to be very backward. At the end of the quarter cornfields still looked green. The harvest in the southern counties was not expected to begin for five or six weeks, and in the more northern counties, the crops were not expected to ripen until towards the end of August. Hay-making had been frequently interrupted by rain, and much hay was spoiled.

The mean temperature of April, May, and June, was  $47^{\circ}\cdot7$ ,  $51^{\circ}\cdot9$ , and  $54^{\circ}\cdot8$  respectively; in April it was  $1^{\circ}\cdot7$  in excess of the average of 100 years, in May  $0^{\circ}\cdot7$  in defect, and in June it was  $3^{\circ}\cdot4$  in defect of the average of 100 years. The fall of rain was 1·3 inches and 1·1 inches in excess in April and June respectively, and 1·3 inches in defect in May.

*Wheat was in ear* on the 1st of June at Wisbech; on the 13th at Helston; on the 15th at Cardington; on the 18th at Silloth; on the 20th at Weybridge; on the 26th at Boston; and on the 29th at Hawarden. *In flower* on the 9th of June at Taunton; on the 21st at Helston; on the 24th at Weybridge and Chiselhurst; on the 26th at Cardington; on the 27th at Silloth; and on the 28th at Hull.

*Barley was in ear* on the 15th of June at Cardington; on the 21st at Weybridge; and on the 24th at Helston. *In flower* on the 26th of June at Cardington; and on the 30th at Weybridge and Hawarden.

*Rye was in ear* on the 14th of June at Weybridge. *In flower* on the 18th of June at Weybridge; and on the 20th at Chiselhurst. And on the 1st of July at Hull.

*Oats were in ear* on the 17th of June at Weybridge Heath and Helston; and *in flower* on the 23rd at Weybridge Heath.

*Third Quarter (July, August, September).*—The cold weather which

had been generally prevalent throughout the preceding quarter continued, with the slight exception of the few days from July 14th to 21st, until August 5th. This was followed by a period of 42 days of warm and genial weather, extending from August 6th to September 16th, during which interval the mean excess of temperature above the average was  $4\frac{1}{2}^{\circ}$  daily. From this time to the end of the quarter the weather was again cold, and heavy rain fell everywhere; the average deficiency of temperature was  $3\frac{1}{4}^{\circ}$  daily.

In the middle of August all crops were backward, but the fine and forcing weather which followed brought them rapidly to maturity almost simultaneously. The gathering in of the harvest, however, was much delayed by the scarcity of labour. By the end of August a large portion of the crops had been stacked. At the end of the quarter the rain was very beneficial in the south of England, but interfered with the completion of the harvest in Scotland, and also in some backward Irish districts. There were considerable complaints about the spread of the potato disease at different times during the quarter, by the completely rotting away of the tuber, so that the stems were left without tubers attached. Generally the wheat crop was considered deficient.

The mean temperature of July was  $61^{\circ}\cdot7$ , being  $0^{\circ}\cdot1$  higher than the average of 100 years; in August it was  $64^{\circ}\cdot8$ , or  $4^{\circ}\cdot0$  higher than the average; and in September it was  $57^{\circ}\cdot4$ , or  $0^{\circ}\cdot9$  higher than the average of 100 years. The fall of rain was  $0\cdot7$  inch and  $1\cdot5$  inches respectively in defect in July and August, and  $1\cdot7$  inches in excess in September.

Local reports relating to the harvest were as follows:—At Helston the report of the coming wheat crop, in July, was not encouraging; it was said to be generally thin. Barley was also thin. Oats were better, but not abundant. Hay, though a fair crop, had been badly saved, and much destroyed. Disease had made its appearance in the potatoes since the hot weather set in. At Strathfield Turgiss, in Hants, in July of the previous year, farmers were busy carting wheat, whereas last year none was then ripe. At Halifax, in August, the grain crops were good; in many cases a second crop of grass had been cut and well got in; and the turnip crop was plentiful and healthy. At Miltown, Banbridge, in Ireland, it was reported that the harvest was very good, wheat was a fair crop, oats extremely good, and green crops abundant; the disease had, however, visited the potato crop, which had suffered severely. At Cumberland, in September, local reports stated that cereal crops were rather below the average; turnips, swedes, and mangolds saved. Potatoes much diseased on strong heavy land, fully five-sixths of the crops destroyed; on peaty and sandy soils the result was more favourable.



METEOROLOGICAL OBSERVATIONS RECORDED AT THE ROYAL OBSERVATORY, GREENWICH, IN THE FIRST SIX MONTHS OF THE YEAR 1871.

1871. MONTHS.		Temperature of										Elastic Force of Vapour.		Weight of a Cubic Foot of Air.	
		Air.		Evaporation.		Dew Point.		Air—Daily Range.		Water of the Thames.					
		Mean.	Diff. from average of 100 years.	Mean.	Diff. from average of 30 years.	Mean.	Diff. from average of 30 years.	Mean.	Diff. from average of 30 years.	Mean.	Diff. from average of 30 years.	Mean.	Diff. from average of 30 years.	Mean.	Diff. from average of 30 years.
January	..	33.2	-3.1	32.0	-4.9	29.7	-5.2	8.1	-1.6	0	0	0.165	-0.037	2.0	-0.4
February		42.4	+3.9	40.5	+3.0	38.1	+3.2	10.7	-0.7	40.1	40.1	0.230	+0.025	2.7	+0.3
March	..	44.9	+4.0	42.0	+2.9	38.7	+2.5	18.2	+3.7	45.3	45.3	0.235	+0.021	2.7	+0.2
Mean	..	40.2	+1.6	38.2	+0.3	35.5	+0.2	12.3	+0.5	42.7	42.7	0.210	+0.003	2.5	0.0
April	..	47.7	+1.7	45.2	+1.2	42.5	+1.9	16.6	-2.0	49.0	49.0	0.272	+0.018	3.1	+0.2
May	..	51.9	-0.7	47.8	-1.5	43.7	-1.9	22.3	+1.8	54.2	54.2	0.285	-0.019	3.3	-0.2
June	..	54.8	-3.4	51.5	-3.2	48.4	-2.3	18.3	-2.8	60.0	60.0	0.340	-0.032	3.9	-0.3
Mean	..	51.5	-0.8	48.2	-1.2	44.9	-0.8	19.1	-1.0	54.4	54.4	0.299	-0.011	3.4	-0.1

NOTE.—In reading this Table it will be borne in mind that the sign (-) minus signifies below the average, and that the sign (+) plus signifies above the average.

METEOROLOGICAL OBSERVATIONS RECORDED AT THE ROYAL OBSERVATORY, GREENWICH, IN THE FIRST SIX MONTHS OF THE YEAR 1871.

1871. MONTHS.	Degree of Humidity.		Reading of Barometer.		Weight of a Cubic Foot of Air.		Rain.		Daily Horizontal movement of the Air.	Reading of Thermometer on Grass.					
	Mean.	Diff from average of 30 years.	Mean.	Diff. from average of 30 years.	Mean.	Diff. from average of 56 years.	Amount.	in.		in.	Number of Nights it was			Lowest Reading at Night.	Highest Reading at Night.
											At or below 30°.	Between 30° and 40°.	Above 40°.		
January ..	87	- 1	29·646	+ 4	558	+ 0·2	2·1	0	23	8	0	12·0	0	34·5	
February ..	86	+ 1	29·847	- 2	551	- 0·5	1·1	0	5	22	1	23·0	1	44·3	
March ..	79	- 3	29·875	- 1	549	- 0·5	1·1	0	17	12	2	21·4	2	44·0	
Mean ..	84	- 1	29·789	0	553	- 0·7	4·3	0	45	42	3	12·0	3	44·3	
April ..	83	+ 5	29·647	- 2	541	+ 1·3	3·0	0	8	11	11	15·8	11	46·5	
May ..	74	- 2	29·907	0	541	- 1·3	0·7	0	10	14	7	26·0	7	49·0	
June ..	78	+ 4	29·761	+ 3	535	+ 1·1	3·0	0	1	8	21	28·8	21	56·6	
Mean ..	78	+ 3	29·772	0	539	+ 1·1	6·7	0	19	33	39	15·8	39	56·6	

NOTE.—In reading this Table it will be borne in mind that the sign (-) minus signifies below the average, and that the sign (+) plus signifies above the average.

METEOROLOGICAL OBSERVATIONS RECORDED AT THE ROYAL OBSERVATORY, GREENWICH, IN THE LAST SIX MONTHS OF THE YEAR 1871.

1871. MONTHS.	Temperature of												Elastic Force of Vapour.		Weight of a Cubic Foot of Air.	
	Air.		Evaporation.		Dew Point.		Air—Daily Range.		Water of the Thames.		Mean.	Diff. from average of 30 years.	Mean.	Diff. from average of 30 years.	Mean.	Diff. from average of 30 years.
	Mean.	Diff. from average of 100 years.	Mean.	Diff. from average of 30 years.	Mean.	Diff. from average of 30 years.	Mean.	Diff. from average of 30 years.	Mean.	Diff. from average of 30 years.	in.	in.	grs.	grs.	grs.	grs.
July ..	61.7	+0.1	57.5	0.0	53.9	+0.1	0	18.6	0	63.8	0.416	+0.001	4.6	0.0		
August ..	64.8	+4.0	59.1	+1.8	54.4	+0.7	+4.7	24.3	+4.7	66.7	0.424	+0.008	4.7	+0.1		
September..	57.4	+0.9	53.5	-0.6	49.9	-1.3	-1.2	17.3	-1.2	61.3	0.360	-0.021	4.0	-0.2		
Mean ..	61.3	+1.7	56.7	+0.4	52.7	-0.3	+0.3	20.1	+0.3	63.9	0.400	-0.004	4.4	0.0		
October ..	49.4	-0.2	47.3	-1.1	45.1	-1.1	0	16.7	+2.0	52.3	0.301	-0.013	3.5	-0.2		
November ..	37.6	-4.7	35.8	-5.7	33.4	-6.3	-1.3	10.4	-1.3	42.6	0.191	-0.058	2.2	-0.6		
December ..	38.3	-0.8	36.9	-1.9	35.0	-1.9	-1.5	8.0	-1.5	37.1	0.204	-0.018	2.4	-0.2		
Mean ..	41.8	-1.9	40.0	-2.9	37.8	-3.1	-0.3	11.7	-0.3	44.0	0.232	-0.030	2.7	-0.3		

NOTE.—In reading this Table it will be borne in mind that the sign (-) minus signifies below the average, and that the sign (+) plus signifies above the average.

METEOROLOGICAL OBSERVATIONS RECORDED AT THE ROYAL OBSERVATORY, GREENWICH, IN THE LAST SIX MONTHS OF THE YEAR 1871.

( VII )

1871. MONTHS.	Degree of Humidity.		Reading of Barometer.		Weight of a Cubic Foot of Air.		Rain.		Daily Horizontal movement of the Air.	Reading of Thermometer on Grass.					
	Mean.	Diff. from average of 30 years.	Mean.	Diff. from average of 30 years.	Mean.	Diff. from average of 30 years.	Amount.	in.		Miles	At or below 30°.	Between 30° and 40°.	Above 40°.		
														Lowest Reading at Night.	Highest Reading at Night.
July .. ..	76	+ 1	29.690	- 0.117	526	- 2	3.3	in.	292	0	1	30	0	39.3	60.7
August ..	69	- 8	29.855	+ 0.063	526	- 3	0.9	in.	215	0	4	27	0	36.4	60.5
September	76	- 5	29.719	- 0.095	532	- 1	4.1	in.	238	2	8	20	2	27.3	52.7
Mean .. ..	74	- 4	29.755	- 0.050	528	- 2	8.3	Sum	Mean	Sum	Sum	Sum	Sum	Lowest	Highest
									248	2	13	77		27.3	60.7
October ..	86	- 1	29.785	+ 0.083	542	+ 3	1.4	in.	Miles	9	12	10	0	24.4	49.0
November ..	85	- 2	29.816	+ 0.045	556	- 8	0.6	in.	193	21	6	3	0	16.6	42.7
December ..	88	0	29.925	+ 0.119	557	+ 5	1.2	in.	189	17	14	0	0	11.0	39.5
Mean .. ..	86	- 1	29.842	+ 0.082	552	0	3.2	Sum	Mean	Sum	Sum	Sum	Sum	Lowest	Highest
									212	47	32	13		11.0	49.0

NOTE.—In reading this Table it will be borne in mind that the sign (-) minus signifies below the average, and that the sign (+) plus signifies above the average.

*Fourth Quarter (October, November, December).*—The last quarter of the year 1871 was remarkable for the longest continuance of low temperature during November and the first half of December in this century. The temperature of the month of October had been nearly a degree below the average, but on the 2nd November a period of cold weather set in of unprecedented length, continuing throughout the whole month. The mean temperature of this month was  $37^{\circ}6$ , being  $4^{\circ}7$  below its average derived from 100 years, observation. In two instances only, viz., in the years 1782 and 1786, was the mean temperature of November lower than  $37^{\circ}6$ , and since the year 1786, that is in the last 85 years, there has been no instance of such a cold November. The cold continued into December and with severity until the 12th day, the average deficiency of the mean daily temperature from the 1st to the 12th being  $9\frac{1}{4}^{\circ}$ . On the 8th December the deficiency reached  $19^{\circ}3$ , the mean temperature of that day having been  $22^{\circ}4$ , while its average is  $41^{\circ}7$ .

The rain-fall during the quarter, as measured at Greenwich, amounted to only 3·2 in., being 4 in. below the average.

The fall of rain in October was only one-half of the average for that month; in November it was only one-fourth; and in December it was three-fifths of its average; thus the rain-fall in each month of the quarter was defective.

A local report from Strathfield Turgiss stated that the weather in *October* was most favourable for getting out farmyard manure, ploughing, and feeding off root crops preparatory for the wheat, which had been got into the ground in good order, and was looking quite gay. All early turnips were of good size, but mangolds and swedes were smaller than usual. In *November* the severe frosts several times hindered the wheat sowing; the milder weather, however, at the end of the month made the ground so favourable that but little harrowing was required before putting in the seed. Feeding off the turnips has been effected under more favourable circumstances than usual, no waste of food having occurred from wet weather; the sheep had also made good progress in laying-on flesh. Lean bullocks and sheep had fallen slightly in value, but still retained too high a price to leave much profit for the winter's keep. The month of *December* was very satisfactory for the finishing up of the wheat-sowing, which had been kept back by the severe frosts of previous month. There had been less wheat showing itself above ground this Christmas than in previous seasons, but within the last few days a considerable breadth had peeped up; this would seem to indicate a late harvest for 1872; but past experience would tend to show that the time of ripening does not depend on the time of sowing.



## CORN : IMPORTATIONS, SALES, AND PRICES.

QUANTITIES of WHEAT, WHEATMEAL and FLOUR, BARLEY, OATS, PEAS and BEANS, IMPORTED into the UNITED KINGDOM in the Year 1871.

1871.	Wheat.	Wheatmeal and Flour.	Barley.	Oats.	Peas.	Beans.
	cwts.	cwts.	cwts.	cwts.	cwts.	cwts.
January ..	3,025,768	389,698	439,468	312,982	33,022	158,031
February ..	1,955,996	288,349	419,274	56,920	1,647	169,226
March ..	2,628,686	421,652	619,244	459,283	51,177	202,166
April ..	2,282,936	385,508	648,073	584,512	68,955	172,008
May ..	2,406,321	297,221	677,507	905,567	176,776	213,840
June ..	2,453,851	331,737	608,682	1,579,322	142,252	207,237
In first Six Months }	14,753,558	2,114,165	3,412,248	3,898,586	473,829	1,122,508
July ..	4,633,120	342,113	523,042	1,586,083	91,706	245,558
August ..	4,110,189	337,998	895,172	1,352,865	72,908	310,063
September ..	3,842,084	204,127	459,134	1,253,501	33,965	328,634
October ..	5,026,387	348,608	1,155,443	1,088,706	42,678	384,734
November ..	4,104,197	298,073	1,373,808	1,059,029	161,144	343,395
December ..	2,938,111	339,554	770,212	768,336	145,720	240,759
In last Six Months }	24,654,088	1,870,473	5,176,811	7,108,520	548,121	1,853,143
Year ..	39,407,646	3,984,638	8,589,059	11,007,106	1,021,950	2,975,651

NOTE.—The average weights *per quarter* of corn, as adopted in the office of the Inspector-General of Imports and Exports, are as follow:—For wheat, 485½ lbs., or 4½ cwts.; for barley, 400 lbs., or 3½ cwts.; for oats, 308 lbs., or 2¾ cwts. Corn has been entered and charged with duty by *weight* instead of *measure* since September, 1864.

COMPUTED REAL VALUE of CORN IMPORTED into the UNITED KINGDOM in each of the FIVE YEARS, 1867-71.

	1867.	1868.	1869.	1870.	1871.
	£.	£.	£.	£.	£.
Wheat .. .. .	24,985,096	22,069,353	19,515,758	16,264,027	23,345,630
Barley .. .. .	2,832,515	3,799,527	3,379,775	2,831,844	3,407,425
Oats .. .. .	4,319,908	3,875,929	3,340,494	4,381,607	4,001,687
Maize .. .. .	3,834,734	4,838,012	5,935,665	5,790,550	6,470,789
Other kinds .. ..	1,778,954	1,981,553	1,376,087	1,498,043	1,729,048
Wheat Flour .. ..	3,519,577	2,832,077	3,792,939	3,383,751	3,438,284
Other kinds of Flour	93,350	23,839	6,640	19,822	10,712
Total of Corn ..	41,364,134	39,420,290	37,347,358	34,169,644	42,403,575

QUANTITIES of BRITISH WHEAT SOLD in the Towns from which Returns are received under the Act of the 27th & 28th VICTORIA, cap. 87, and their AVERAGE PRICES, in each of the TWELVE MONTHS of the Years 1866-71.

	QUANTITIES IN QUARTERS.					
	1866.	1867.	1868.	1869.	1870.	1871.
	quarters.	quarters.	quarters.	quarters.	quarters.	quarters.
First month ..	212,713	221,791	193,077	248,047	187,027	267,827
Second month	259,999	203,900	201,325	258,883	231,428	309,376
Third month } (five weeks)	331,295	280,878	235,402	278,086	314,040	377,003
Fourth month	250,159	205,231	173,120	204,519	242,457	293,494
Fifth month ..	250,890	221,067	162,030	238,483	281,620	222,003
Sixth month } (five weeks)	245,393	196,985	128,142	268,599	296,028	229,749
Seventh month	127,836	109,829	106,812	166,485	171,005	120,154
Eighth month	191,057	102,303	174,633	174,904	201,788	123,889
Ninth month } (five weeks)	325,056	265,668	444,296	255,286	435,398	371,590
Tenth month	320,674	349,788	284,810	256,984	340,445	367,672
Eleventh month	284,530	265,622	268,848	220,876	298,407	269,351
Twelfth month } (five weeks)	332,934	301,558	307,386	244,933	352,629	322,756

	AVERAGE PRICES PER QUARTER.					
	1866.	1867.	1868.	1869.	1870.	1871.
	s. d.	s. d.	s. d.	s. d.	s. d.	s. d.
First month ..	45 10	61 5	70 4	51 10	43 11	52 8
Second month	45 7	60 11	72 11	50 10	41 10	53 6
Third month } (five weeks)	45 4	59 9	73 1	48 5	41 3	54 6
Fourth month	44 10	61 7	73 4	46 4	42 7	58 2
Fifth month ..	46 3	64 8	74 3	44 8	43 10	59 1
Sixth month } (five weeks)	48 3	65 5	68 9	45 10	47 0	59 8
Seventh month	54 1	65 1	65 6	49 5	50 9	58 7
Eighth month	50 7	68 0	57 9	52 1	53 11	57 11
Ninth month } (five weeks)	49 0	63 5	55 1	51 4	47 0	57 0
Tenth month ..	52 4	66 7	53 11	47 8	47 4	56 5
Eleventh month	56 6	69 9	52 2	46 8	50 1	56 2
Twelfth month } (five weeks)	60 3	67 7	50 2	44 2	52 4	56 2

AVERAGE PRICES of BRITISH CORN per Quarter (imperial measure) as received from the INSPECTORS and OFFICERS of EXCISE according to the Act of 27th & 28th VICTORIA, cap. 87, in each of the FIFTY-TWO WEEKS of the Year 1871.

Week ending	Wheat.		Barley.		Oats.	Week ending	Wheat.		Barley.		Oats.		
	s.	d.	s.	d.	s.	d.	s.	d.	s.	d.	s.		
January 7..	52	6	34	11	23	0	July 8 ..	59	0	34	10	27	1
January 14..	53	1	35	2	23	5	July 15 ..	58	6	34	7	27	10
January 21..	52	9	35	9	22	9	July 22 ..	58	10	35	11	27	2
January 28..	52	6	35	5	22	8	July 29 ..	58	0	34	3	28	3
February 4..	52	10	35	4	23	11	August 5 ..	58	0	36	7	27	4
February 11..	53	7	35	8	23	9	August 12 ..	58	5	35	11	26	6
February 18..	53	11	35	7	23	7	August 19 ..	57	10	35	9	27	6
February 25..	53	9	35	10	24	5	August 26 ..	57	4	32	7	26	7
March 4..	53	2	35	5	24	7	September 2	57	2	35	0	26	4
March 11..	53	8	36	0	24	10	September 9	56	6	35	1	26	0
March 18..	54	7	36	1	25	7	September 16	56	7	35	8	24	9
March 25..	55	2	36	3	25	10	September 23	57	7	35	6	23	6
April 1..	55	9	36	6	26	4	September 30	57	3	35	10	23	10
Average of Winter Quarter	53	7	35	8	24	2	Average of Summer Quarter	57	9	35	2	26	4
April 8..	56	7	36	8	26	10	October 7 ..	56	3	35	8	23	8
April 15..	57	6	36	5	26	5	October 14 ..	56	5	36	2	22	6
April 22..	58	11	37	3	27	9	October 21 ..	56	6	36	10	23	2
April 29..	59	7	36	9	27	9	October 28 ..	56	7	37	7	23	5
May 6..	58	11	37	3	26	10	November 4	56	8	37	5	23	8
May 13..	58	7	37	10	26	11	November 11	56	5	37	4	23	5
May 20..	58	10	37	7	27	11	November 18	55	11	36	9	23	0
May 27..	59	11	36	3	27	2	November 25	55	10	36	8	23	8
June 3..	60	0	36	11	27	7	December 2	56	7	36	10	23	8
June 10..	59	9	38	6	25	11	December 9	56	10	37	1	24	2
June 17..	59	7	35	11	26	10	December 16	56	5	37	1	22	10
June 24..	59	11	36	10	27	8	December 23	55	8	36	9	23	0
July 1..	59	1	36	10	27	5	December 30	55	4	35	5	22	0
Average of Spring Quarter	59	9	37	0	27	0	Average of Autumn Quarter	56	3	36	9	23	2

NOTE.—The system of preparing the Monthly Trade Accounts of the United Kingdom has been altered since the commencement of the year 1871, with the view of providing earlier and more accurate information.

The quantities of articles imported are now taken from the "Importers' Entries," instead of from the "Landing Accounts," which are not completed until a much later date: the figures given for the Imports in January, 1871, will not, therefore, compare with those given for the months of January, 1869 and 1870—the former showing the complete Importations of the month, and the latter only the Returns of the Landing Accounts so far as received within the month, by which method the last seven to ten days' Importations of the month were excluded. So great a divergence will not occur in subsequent months.

The Import Account for the month of December, 1871, will in many cases exhibit a considerable deficiency when compared with the month of December in

QUANTITIES OF WHEAT, BARLEY, OATS, PEAS, BEANS, INDIAN CORN or MAIZE, WHEATMEAL and FLOUR, IMPORTED in the THREE YEARS 1869-70-71; also the COUNTRIES from which the WHEAT, WHEATMEAL, and FLOUR were obtained.

	1869.	1870.	1871.
Wheat from—	cwts.	cwts.	cwts.
Russia .. .. .	9,158,331	10,269,198	15,629,435
Denmark .. .. .	549,811	327,919	130,370
Germany .. .. .	6,149,030	3,348,214	3,049,031
France .. .. .	468,274	253,644	134,841
Austrian Territories .. .. .	1,030,563	60,472	239,147
Turkey and Wallachia and Moldavia	2,379,906	489,421	1,418,886
Egypt .. .. .	1,004,479	104,950	884,396
United States .. .. .	13,181,507	12,371,922	13,405,057
Chili .. .. .	567,107	599,337	549,529
British North America .. .. .	2,723,053	2,838,361	3,279,264
Other countries .. .. .	483,767	237,791	687,690
<b>Total Wheat .. .. .</b>	<b>37,695,828</b>	<b>30,901,229</b>	<b>39,407,646</b>
Barley .. .. .	8,053,660	7,217,327	8,589,059
Oats .. .. .	7,916,870	10,830,630	11,007,106
Peas .. .. .	1,054,387	1,799,354	1,021,950
Beans .. .. .	1,897,220	1,505,798	2,975,651
Indian Corn, or Maize .. .. .	17,664,113	16,756,783	16,832,499
Wheatmeal and Flour from—			
Germany .. .. .	1,118,126	911,108	967,892
France .. .. .	1,348,061	645,181	37,150
United States .. .. .	1,711,000	2,148,251	1,794,805
British North America .. .. .	538,766	451,463	403,989
Other countries .. .. .	685,602	647,906	780,802
<b>Total Wheatmeal and Flour</b>	<b>5,401,555</b>	<b>4,803,909</b>	<b>3,984,638</b>
Indian Corn Meal .. .. .	6,039	5,741	7,881

previous years. This circumstance should not be taken to indicate a decrease in the trade of the month, inasmuch as in former years the account for December was not published until the end of the following February, and embraced the record of large quantities of goods imported in previous months, but not registered until the "Landing Accounts" had been received.

AVERAGE PRICES of Consols, of Wheat, of Meat, and of Potatoes; also the AVERAGE NUMBER of PAUPERS relieved on the *last day* of each Week; and the MEAN TEMPERATURE, in each of the Twelve Quarters ending December 31st, 1871.

Years ending	AVERAGE PRICES.						PAUPERISM.		Mean Temperature.
	Consols (for Money).	Minimum Rate per Cent. of Discount charged by the Bank of England.	Wheat per Quarter in England and Wales.	Meat per lb. at the Metropolitan Meat Market (by the Carcase).		Potatoes (York Regents) per Ton, at Waterside Market, Southwark.	Quarterly Average of the Number of Paupers relieved on the <i>last day</i> of each week.		
				Beef.	Mutton.		In-door.	Out-door.	
69	£.		s. d.						°
31	92 $\frac{3}{8}$	3·0	50 2	4 $\frac{3}{4}$ d.—7 $\frac{1}{4}$ d. Mean 6d.	4 $\frac{3}{4}$ d.—7 $\frac{1}{4}$ d. Mean 6 $\frac{1}{8}$ d.	70s.—140s. Mean 105s.	162,308	850,883	41·3
30	93 $\frac{3}{8}$	4·2	45 7	4 $\frac{3}{4}$ d.—7 $\frac{3}{8}$ d. Mean 6 $\frac{1}{8}$ d.	5d.—7 $\frac{3}{8}$ d. Mean 6 $\frac{3}{8}$ d.	60s.—130s. Mean 95s.	145,094	816,260	52·0
30	93	2·9	50 11	4 $\frac{3}{4}$ d.—7 $\frac{1}{2}$ d. Mean 6 $\frac{1}{8}$ d.	5 $\frac{1}{2}$ d.—7 $\frac{1}{2}$ d. Mean 6 $\frac{3}{8}$ d.	95s.—125s. Mean 110s.	137,406	781,382	61·4
31	93 $\frac{3}{8}$	2·8	46 0	4 $\frac{3}{4}$ d.—7 $\frac{1}{4}$ d. Mean 6 $\frac{1}{8}$ d.	5d.—7 $\frac{1}{2}$ d. Mean 6 $\frac{1}{2}$ d.	75s.—100s. Mean 87s. 6d.	152,021	813,753	43·3
70									
31	92 $\frac{5}{8}$	3·0	42 3	4 $\frac{1}{2}$ d.—7d. Mean 5 $\frac{3}{4}$ d.	5 $\frac{1}{2}$ d.—7 $\frac{1}{2}$ d. Mean 6 $\frac{1}{4}$ d.	95s.—110s. Mean 102s. 6d.	164,387	892,822	38·0
30	94	3·0	44 8	4 $\frac{1}{2}$ d.—6 $\frac{3}{4}$ d. Mean 5 $\frac{5}{8}$ d.	5 $\frac{1}{2}$ d.—7 $\frac{1}{2}$ d. Mean 6 $\frac{3}{8}$ d.	115s.—135s. Mean 125s.	144,226	825,337	54·4
30	91 $\frac{7}{8}$	3·9	50 4	4 $\frac{3}{4}$ d.—7 $\frac{1}{4}$ d. Mean 6d.	5 $\frac{1}{2}$ d.—8d. Mean 6 $\frac{3}{8}$ d.	100s.—140s. Mean 120s.	138,444	787,976	60·7
31	92 $\frac{5}{8}$	2·5	50 1	5d.—7 $\frac{3}{8}$ d. Mean 6 $\frac{3}{8}$ d.	5 $\frac{1}{4}$ d.—8d. Mean 6 $\frac{3}{8}$ d.	50s.—90s. Mean 70s.	150,729	802,291	41·6
71									
31	92 $\frac{1}{8}$	2·7	53 7	5d.—7 $\frac{3}{8}$ d. Mean 6 $\frac{3}{8}$ d.	5 $\frac{1}{4}$ d.—7 $\frac{3}{8}$ d. Mean 6 $\frac{1}{2}$ d.	75s.—100s. Mean 87s. 6d.	160,984	878,892	40·2
30	93 $\frac{3}{8}$	2·5	59 9	5 $\frac{1}{2}$ d.—7 $\frac{3}{4}$ d. Mean 6 $\frac{1}{2}$ d.	5 $\frac{1}{2}$ d.—8 $\frac{1}{2}$ d. Mean 7d.	51s.—76s. Mean 63s. 6d.	140,338	805,519	51·5
30	93 $\frac{3}{8}$	2·2	57 9	5 $\frac{1}{2}$ d.—8d. Mean 6 $\frac{3}{4}$ d.	5 $\frac{3}{4}$ d.—9d. Mean 7 $\frac{1}{2}$ d.	60s.—77s. Mean 68s. 6d.	132,065	769,482	61·3
31	93	4·2	56 3	5d.—7 $\frac{3}{8}$ d. Mean 6 $\frac{1}{2}$ d.	5 $\frac{1}{2}$ d.—8 $\frac{1}{4}$ d. Mean 6 $\frac{3}{4}$ d.	75s.—104s. Mean 89s. 6d.	140,955	758,474	41·8

**ACREAGE under each Description of CROP, FALLOW, and  
GREAT BRITAIN and**

DESCRIPTION OF CROPS and LIVE STOCK.	GREAT BRITAIN.		
	1869.	1870.	1871.
<b>CORN CROPS:—</b>	Acres.	Acres.	Acres.
Wheat .. .. .	3,688,357	3,500,543	3,571,894
Barley or Bere .. .. .	2,251,480	2,371,739	2,385,783
Oats .. .. .	2,782,720	2,763,300	2,715,707
Rye .. .. .	64,099	65,166	71,495
Beans .. .. .	575,204	530,095	540,835
Peas .. .. .	396,177	317,198	389,547
<b>TOTAL CORN CROPS .. ..</b>	<b>9,758,037</b>	<b>9,548,041</b>	<b>9,675,261</b>
<b>GREEN CROPS:—</b>			
Potatoes .. .. .	585,211	587,661	627,691
Turnips and Swedes .. .. .	2,171,526	2,210,911	2,163,744
Mangold .. .. .	292,742	306,531	360,517
Carrots .. .. .	14,344	15,259	20,154
Cabbage, Kohl-rabi, and Rape .. ..	145,251	143,930	178,919
Vetches, Lucerne, and any other crop (except clover or grass) .. .. .	365,993	322,438	387,155
<b>TOTAL GREEN CROPS .. ..</b>	<b>3,575,067</b>	<b>3,586,730</b>	<b>3,738,180</b>
<b>OTHER CROPS, GRASS, &amp;c. :—</b>			
Flax .. .. .	20,923	23,957	17,366
Hops .. .. .	61,792	60,594	60,030
Bare fallow or uncropped arable land	738,836	610,517	542,840
Clover and artificial and other grasses } under rotation .. .. . }	3,448,726	4,504,884	4,369,448
Permanent pasture, meadow, or grass } not broken up in rotation (exclusive } of heath or mountain land) .. .. }	12,735,897	12,072,856	12,435,442
<b>LIVE STOCK:—</b>	No.	No.	No.
Cattle .. .. .	5,313,473	5,403,317	5,337,759
Sheep .. .. .	29,538,141	28,397,589	27,119,569
Pigs .. .. .	1,930,452	2,171,138	2,499,602
Total number of horses used for agriculture, unbroken horses, and mares kept solely for breeding .. .. .	..	1,266,709	1,254,450
Acreege of orchard, or of arable or grass- land, used also for fruit-trees .. .. }	..	..	206,583
Acreege of woods, coppices, and plan- tations .. .. . }	..	..	2,175,471

GRASS, and NUMBER of CATTLE, SHEEP, and PIGS, in  
IRELAND, in 1869-70-71.

IRELAND.			UNITED KINGDOM, including the Islands.		
1869.	1870.	1871.	1869.	1870.	1871.
Acres.	Acres.	Acres.	Acres.	Acres.	Acres.
281,117	260,914	246,954	3,981,989	3,773,663	3,831,054
223,338	243,435	222,604	2,483,277	2,623,752	2,616,965
1,684,788	1,648,764	1,633,960	4,480,125	4,424,536	4,362,139
8,770	9,281	9,647	72,986	74,527	81,222
8,833	9,644	9,549	584,251	539,968	550,613
1,124	1,071	1,365	397,483	318,607	391,250
2,207,970	2,173,109	2,124,079	12,000,111	11,755,053	11,833,243
1,041,837	1,043,788	1,058,287	1,635,347	1,639,296	1,693,825
321,880	339,059	327,162	2,502,512	2,559,629	2,500,565
21,029	25,220	31,766	314,421	332,409	392,941
3,702	3,940	4,167	18,831	19,925	25,047
42,237	45,266	43,543	187,667	189,344	222,610
38,210	41,446	46,607	407,155	366,532	436,410
1,468,895	1,498,719	1,511,532	5,065,933	5,107,135	5,271,398
229,178	194,893	156,883	250,112	218,870	174,269
..	..	..	61,792	60,594	60,030
20,981	19,054	22,323	761,369	630,294	565,886
1,669,800	1,775,835	1,827,733	5,149,552	6,320,126	6,236,588
10,046,877	9,990,968	10,068,848	22,811,284	22,085,295	22,525,761
No.	No.	No.	No.	No.	No.
3,727,794	3,796,380	3,973,102	9,078,282	9,235,052	9,346,216
4,648,158	4,333,984	4,228,721	34,250,272	32,786,783	31,403,500
1,079,793	1,459,332	1,616,754	3,028,394	3,650,730	4,136,616
..	531,306	537,633	..	1,808,040	1,802,108

AVERAGE PRICES of BRITISH WHEAT, BARLEY, and OATS, per IMPERIAL  
QUARTER, in each of the SIXTEEN YEARS 1856-71.

Year.	Wheat.	Barley.	Oats.	Year.	Wheat.	Barley.	Oats.
	s. d.	s. d.	s. d.		s. d.	s. d.	s. d.
1856	69 2	41 1	25 2	1864	40 2	29 11	20 1
1857	56 4	42 1	25 0	1865	41 10	29 9	21 10
1858	44 2	34 8	24 6	1866	49 11	37 5	24 7
1859	43 9	33 6	23 2	1867	64 6	40 0	26 1
1860	53 3	36 7	24 5	1868	63 9	43 0	28 1
1861	55 4	36 1	23 9	1869	48 2	39 5	26 0
1862	55 5	35 1	22 7	1870	46 10	34 7	22 10
1863	44 9	33 11	21 2	1871	56 10	36 2	25 2

CERTAIN ARTICLES of FOREIGN and COLONIAL PRODUCTION IMPORTED in the YEARS  
1868-71; and their QUANTITIES.

	1868.	1869.	1870.	1871.
<b>ANIMALS, Living :</b>				
Oxen, Bulls, and Cows, number	114,869	190,674	170,647	208,772
Calves .. .. .	21,819	29,516	31,525	40,139
Sheep .. .. .	323,447	691,472	651,138	916,799
Lambs .. .. .	17,708	18,371	18,767	
Swine and Hogs .. .. .	33,721	69,067	95,624	85,622
Bones (burnt or not, or as animal charcoal) .. .. . tons	75,851	95,980	94,923	94,212
Cotton, Raw .. .. . cwts.	11,857,893	10,900,818	11,931,979	15,843,890
Flax .. .. .	1,816,669	1,542,201	2,373,528	2,597,915
Guano .. .. .	182,343	210,010	280,311	178,678
Hemp .. .. .	1,076,198	1,055,769	1,108,839	1,320,747
Hops .. .. .	231,720	322,515	127,013	220,409
Hides untanned: Dry .. .. .	305,318	340,449	527,809	599,922
"    "    Wet .. .. .	635,794	524,899	670,941	678,432
Petroleum .. .. . tuns	17,160	21,439	27,220	35,808
Oilseed Cakes .. .. . tons	162,339	159,295	158,211	162,613
Potatoes .. .. . cwts.	2,041,474	1,660,189	772,003	852,125
Butter .. .. .	1,097,539	1,259,089	1,159,481	1,337,808
Cheese .. .. .	873,377	979,189	1,041,281	1,219,056
Eggs .. .. . per great hundred	3,199,742	3,684,772	3,590,352	1,351,106
Lard .. .. . cwts.	237,260	255,964	217,696	477,147
Bacon and Hams .. .. .	638,127	740,193	567,164	1,143,873
Salt Beef .. .. .	240,577	214,955	203,713	279,179
Salt Pork .. .. .	144,378	165,944	220,533	266,967
Clover Seeds .. .. .	264,878	231,427	155,673	340,377
Flax-seed and Linseed .. .. . qrs.	1,635,528	1,397,066	1,490,695	1,334,945
Rape .. .. .	356,884	260,212	551,107	665,161
Sheep and Lambs' Wool .. .. . lbs.	250,928,854	255,161,344	259,361,963	319,511,336



CERTAIN ARTICLES OF FOREIGN and COLONIAL PRODUCTION IMPORTED in the FOUR YEARS  
1867-70; and their AVERAGE PRICES, exclusive of Duty.

Articles.	Principal Countries whence Imported.	1867.	1868.	1869.	1870.
EN AND BULLS ..	Schleswig Holstein and Holland .. .. each	£. s. d. 17 16 0	£. s. d. 16 16 0	£. s. d. 19 7 0	£. s. d. 17 17 0
WS .. .. .	Schleswig Holstein and Holland .. .. each	17 3 0	14 13 0	16 15 0	15 14 0
LIVES .. .. .	Holland .. .. ,,	4 14 0	4 7 8	4 16 0	4 4 4
EEP .. .. .	Holland .. .. ,,	2 1 5	1 13 10	1 15 0	1 16 9
MBS .. .. .	Holland .. .. ,,	1 5 0	1 3 8	1 6 0	1 6 0
ONES OF ANIMALS AND FISH FOR MANURE .. ..	Various countries in Europe and South America .. .. per ton	5 0 9	5 8 2	6 1 0	6 9 0
TON, RAW .. ..	Egypt .. .. . per cwt. United States .. .. ,, Brazil .. .. . ,, British India .. .. ,,	6 7 9 5 9 1 5 6 3 3 2 10	5 9 4 5 5 4 5 1 8 3 12 8	5 19 7 5 16 1 5 15 6 4 5 8	5 0 8 4 18 0 4 17 5 3 5 6
AX, rough or un- dressed .. ..	Russia and Prussia .. .. ,, Holland .. .. . ,, Belgium .. .. ,,	2 14 9 3 14 11 4 0 0	2 12 4 3 15 0 4 0 0	2 12 4 3 10 10 3 13 4	2 10 2 3 4 6 3 5 0
IANO .. .. .	Peru .. .. . per ton	12 0 0	12 3 0	12 19 0	13 6 0
EMP, rough or un- dressed .. .. .	Russia .. .. . per cwt. Austrian Italy .. .. ,, Philippine Islands .. .. ,, British India .. .. ,,	1 15 2 1 17 1 2 10 6 1 2 3	1 17 1 1 17 10 2 7 5 1 7 11	1 13 1 2 0 9 2 13 0 1 4 8	1 12 10 2 0 9 2 14 8 1 2 11
OPS .. .. .	Hanse Towns .. .. ,, Holland and Belgium .. .. ,, United States .. .. ,,	5 6 3 5 4 8 8 18 10	3 1 6 2 16 2 3 19 0	2 19 0 3 10 4 3 13 0	3 7 0 2 19 0 3 14 0
IDES (untanned) dry	British India .. .. ,, Argentine Confederacy and Uruguay .. per cwt.	3 12 3 2 12 4	4 0 10 2 16 3	4 1 7 2 11 0	3 19 5 2 14 5
" wet	Brazil .. .. . ,, Australia .. .. ,,	2 12 6 1 19 7	2 16 6 2 8 5	2 11 6 2 5 7	2 14 4 2 7 3
ETROLEUM, refined ..	United States .. per gall.	0 1 3 $\frac{3}{4}$	0 1 5 $\frac{1}{2}$	0 1 7 $\frac{3}{8}$	0 1 7 $\frac{1}{2}$
" unrefined	United States .. per tun	11 14 5	11 4 0	13 3 0	14 0 0
LEED CAKES ..	Russia, Denmark, Prussia and Hamburg .. per ton France .. .. . ,, United States .. .. ,,	8 3 4 9 13 6 10 18 0	8 12 0 10 9 4 11 7 9	8 4 0 10 2 0 10 16 0	8 18 0 9 10 0 10 15 0

CERTAIN ARTICLES of FOREIGN and COLONIAL PRODUCTION IMPORTED in the FOUR YEARS  
1867-70; and their AVERAGE PRICES, exclusive of Duty—*continued.*

Articles.	Principal Countries whence Imported.	1867.	1868.	1869.	1870.
		£. s. d.	£. s. d.	£. s. d.	£. s. d.
POTATOES .. .. .	Holland .. .. per cwt.	0 5 11½	0 5 8	0 4 11	0 6 9
	France .. .. .	0 5 6	0 4 7	0 4 7	0 5 7
BUTTER .. .. .	Hanse Towns .. ..	5 13 9	6 9 6	5 18 8	6 2 9
	Holland and Belgium ..	5 8 4	5 15 11	5 9 2	5 18 3
	France .. .. .	5 0 6	5 9 7	5 9 6	5 15 6
	United States .. ..	*2 18 1	5 4 9	4 18 4	4 15 8
CHEESE .. .. .	Holland .. .. .	2 17 10	2 18 3	2 19 2	2 12 4
	United States .. ..	2 15 10	2 18 10	3 6 1	3 7 0
EGGS .. .. .	France .. .. per 120	0 5 11	0 6 3	0 6 0½	0 5 11
LARD .. .. .	United States .. per cwt.	2 10 3	3 3 10	3 12 4	3 6 10
HAMS .. .. .	Hanse Towns .. ..	3 5 5	3 8 5	3 16 11	3 16 4
	United States .. ..	2 7 0	2 15 0	3 7 6	2 19 0
BACON .. .. .	Hanse Towns .. ..	3 4 0	2 8 6	3 12 5	3 8 8
	United States .. ..	2 4 7	2 9 10	3 2 2	2 18 0
BEEF, SALTED .. ..	Hanse Towns .. ..	2 10 1	2 3 9	1 19 7	2 5 10
	United States .. ..	2 7 2	2 5 2	1 14 9	2 1 1
PORK, SALTED (except hams) .. .. .	Hanse Towns .. ..	2 8 6	2 15 3	3 2 0	3 3 1
	United States .. ..	2 1 6	2 5 10	2 16 6	2 18 1
Clover SEEDS .. ..	Hamburg, France and United States .. per cwt.)	3 6 10	3 2 5	3 1 5	3 6 1
LINSEED .. .. .	Russia, Baltic .. per qr.	2 16 4	2 8 10	2 10 2	2 10 11
	Russia, Black Sea ..	3 1 0	2 13 0	2 13 1	2 15 1
	British India .. ..	3 6 9	3 1 8	2 18 9	2 19 1
RAPE .. .. .	Prussia .. .. .	2 13 11	2 12 5	3 1 0	3 5 1
	British India .. ..	2 12 6	2 11 4	2 18 11	3 4 1
SHEEP AND LAMBS' WOOL .. .. .	Russia .. .. . per lb.	0 0 11½	0 0 9	0 0 9	0 0 0
	Hanse Towns .. ..	0 1 10	0 1 4½	0 1 3½	0 1 0
	Argentine Confederacy ..	0 0 6½	0 0 6¼	0 0 4½	0 0 0
	British Possessions in South Africa .. .. per lb.)	0 1 2½	0 1 2½	0 1 2½	0 1 0
	British India .. ..	0 0 7½	0 0 7½	0 0 7½	0 0 0
	Australia .. .. .	0 1 7½	0 1 3½	0 1 2½	0 1 0

\* Imports generally of inferior quality.

## STATISTICS OF DAIRY PRODUCE.

*(The following Quotations, &c., are extracted from 'The Grocer.')*PRICES CURRENT ON 1ST SATURDAY IN JANUARY OF each YEAR, from the latest actual  
MARKET SALES.

	1872.	1871.	1870.	1873.
<b>Butter :</b>	Per cwt.	Per cwt.	Per cwt.	Per cwt.
Carlow, finest, F.O.B. ..	120s. to 134s.	130s. to 144s.	124s. to 130s	128s. to 136s.
Landed .. .. .	116 ,, 136	126 ,, 146	122 ,, 130	126 ,, 140
Cork, 1sts .. .. .	133 ,, 137	142 ,, 150	134 ,, 137	136 ,, 145
,, 2nds .. .. .	124 ,, 129	134 ,, 142	123 ,, 125	133 ,, 140
,, 3rds, new .. ..	106 ,, 118	122 ,, 125	107 ,, 109	125 ,, 128
,, 4ths ,, .. .. .	84 ,, 86	112 ,, 114	100 ,, 104	117 ,, 120
Limerick .. .. .	112 ,, 116	128 ,, 132	116 ,, 120	.. ..
<b>Foreign :</b>				
Friesland .. .. .	106 ,, 116	102 ,, 142	104 ,, 132	120 ,, 134
Jersey, &c. .. .. .	75 ,, 124	76 ,, 130	74 ,, 130	100 ,, 130
Kiel .. .. .	100 ,, 140	110 ,, 156	104 ,, 136	.. ..
Normandy .. .. .	90 ,, 150	.. ..	90 ,, 150	112 ,, 145
American .. .. .	60 ,, 115	94 ,, 116	100 ,, 112	112 ,, 120
<b>Cheese :</b>				
English Cheddar, fine, new	66 ,, 84	.. ..	90 ,, 94	86 ,, 94
,, good ,, .. ..	.. ..	74 ,, 100	74 ,, 86	74 ,, 82
Red Somerset Loaf .. ..	50 ,, 72	80 ,, 92	72 ,, 84	.. ..
White or yellow Cheddar				
Loaf .. .. .	60 ,, 70	80 ,, 92	76 ,, 84	.. ..
Scotch Cheddar .. .. .	60 ,, 70	70 ,, 80	70 ,, 80	64 ,, 74
Cheshire, new .. .. .	70 ,, 84	78 ,, 90	84 ,, 90	80 ,, 90
,, good ditto .. ..	50 ,, 64	60 ,, 74	66 ,, 78	64 ,, 76
Wiltshire, new .. .. .	64 ,, 70	64 ,, 84	72 ,, 80	68 ,, 78
,, good ditto .. ..	50 ,, 60	.. ..	62 ,, 68	62 ,, 64
North Wilts, Loaf, new ..	50 ,, 72	80 ,, 90	76 ,, 84	66 ,, 78
Derby .. .. .	56 ,, 78	68 ,, 86	72 ,, 86	70 ,, 86
<b>Foreign :</b>				
American, fine .. .. .	60 ,, 66	74 ,, 80	72 ,, 75	66 ,, 74
,, good .. .. .	40 ,, 56	60 ,, 68	64 ,, 70	60 ,, 64
Gouda .. .. .	40 ,, 64	50 ,, 64	50 ,, 62	50 ,, 62
Kanter .. .. .	.. ..	.. ..	.. ..	.. ..
Edam, new .. .. .	50 ,, 70	54 ,, 70	54 ,, 65	54 ,, 68

In reviewing the provision market for the year 1871, 'The Grocer' reports that "the butter market for the first two months of the year—or perhaps we shall be right in including March—was greatly influenced by the drought of the summer of 1870, and also (particularly in the months of January and February) by the prohibition of shipments of butter from France. This was occasioned by the war then raging there; and shipments were also lessened

from some other foreign ports by the severity of the weather, this combination of events causing prices to rule unusually high.

“IRISH BUTTER.—Supplies of foreign being greatly diminished, from the causes alluded to above, enabled holders of Irish to show firmness. We commenced the month of January with the asking prices for Clonmels, &c., being 134s. to 150s., landed Corks 142s. to 148s. The close of the month showed little change, their quotations ranging from 10s. to 20s. per cwt. higher than at the corresponding period of the previous year. Low qualities of Corks were, however, then much closer to the prices of first Corks; they are now—say, second Corks from 132s. to 145s., thirds, 132s. to 136s.

In April scarcely any Irish butter was offered for sale; in July, after being without a market price for Clonmels for about eighteen weeks, they were quoted by the end of the month at 112s. to 118s., Corks 121s. to 122s. In October there was a little more doing in Irish butter. In December an advance of 2s. was asked on Clonmels and Corks over the prices in the previous month, but the business transacted at these prices was very limited—more so than has been known for many years past. The want of regularity in the selection, and its general saltiness, have been the chief complaints, the public preferring the milder foreign.

“The quantity of butter brought to the Cork market in 1871 was greater than in any preceding year. The supply for the season, up to December 31st, was about 30,000 firkins over the corresponding period of 1870, and the farmer had higher prices than heretofore. The total receipts for the year 1871 number some 420,000 firkins, exceeding in value 1,500,000*l.*—totals unequalled by any that preceded them in the Cork market.

“FOREIGN BUTTER.—Shipments from France being prohibited, supplies were, in consequence, small. In February fine butter was scarce and dear. In the last week in the month the prohibition of shipments from France was withdrawn, and a few Normandys arrived, for which from 120s. to 170s. were asked. The month of May commenced with civil war still raging in Paris; vegetation was earlier than in 1870, and there were large supplies of foreign butter; Normandys were as low as 100s. to 118s. In November, American butter arrived in Liverpool in much larger quantities than in the same period of 1870. In December, while finest Normandys were saleable at 145s. to 150s., there was a difficulty in moving low qualities at 50s. to 60s. per cwt. less. The stocks of

foreign butter were far larger than usual, the greater part of very inferior quality and almost unsaleable.

“CHEESE.—The month of January commenced with a firm market, and with the feeling that the drought of the last summer had caused such a falling-off in the make that holders would be enabled to clear off all the finest left on hand at full prices. Our quotations will be confined chiefly to Cheddar and Cheshire for English, and American as the representative of foreign. The market quotations for Cheddar scarcely varied from 74s. to 98s. from the first week in January to the end of May; Cheshire 60s. to 90s. January and February, low quality Cheshire 64s.; March and April, finest 90s. to 94s. Throughout May, and the greater part of June, common Cheshire 60s.; in July some inferior parcels could be bought at 50s.; finest, up to the middle of July, 92s. to 94s., when the stocks of fine old were nearly exhausted. New then began to appear, and the plentiful supply and low prices of American began to interfere greatly with the sale of English. The weather was also far more favourable for vegetation than the previous summer—the hay crop was then wretchedly short, whilst that of 1871 was abundant; and the make of cheese, in consequence, differed widely. At the latter end of July the quotations for English were for those of the new season's make. To keep the position of the market fairly in view, American must now be quoted at the same time as English. We must, however, go back to the beginning of the year for American before the change is made; the ranges in prices of American were—from 60s. to 80s., January to the middle of February; then chiefly 56s. to 80s. to the middle of March; common things could then be bought at 54s. in the early part of April, 46s. the latter end, and at 40s. in July; finest American, the end of March and beginning of April, 78s., at the latter end 76s.; early in May 74s., at the end 2s. less; May, 72s. to 70s.; early in June 70s., at the end 64s.; early in July the finest 62s., at the end 58s. The quality being good, and the supplies large, these prices began to tell seriously upon the sales of English, particularly so upon second-rate qualities. A cold and wet summer up to this time had been against the make of fine cheese. In August the range in prices of Cheddar was from 64s. to 76s.; September, 64s. to 78s. Cheshire, in August, 56s. to 75s.; September, 56s. to 80s. American, August, 40s. to 56s.; September, early, 38s. to 56s.; later in the month, 42s. to 60s. The low prices of August induced the dealers to take American somewhat freely. Since then, with liberal supplies of English, the market has been quiet, and quotations have scarcely varied—say, Cheddar chiefly

66s. to 84s.; Cheshire from 52s. to 84s.; and American from 40s. to 66s. The market certainly, at the present time, is not overstocked with finest qualities of either description."

ARTIFICIAL BUTTER.—What becomes of the tallow? Upon this question "The Grocer" has an interesting article. It states that every application of tallow has been invaded, first by vegetable and then by mineral novelties.

"The beauty, cheapness, and brilliancy of the paraffin wax, and the mineral lamp oils, have brought them into use everywhere, among all classes, and in all countries and situations. The tallow candle appears to be going the way of the old tinder-box; and tallow is only used as an exceptionally high-priced and luxurious lubricant. Thus it appears that the demand for tallow is wonderfully diminished, while the Australian supplies are still increasing. How is it, then, that the price of tallow still keeps up? What answer can we give to the question? What *does* become of the tallow?"

"It is well known that vast quantities of kitchen-stuff and Australian fat, which formerly were consumed by the tallow-chandlers and soap-makers, have lately found their way into the empty Dutch and other butter-tubs, which are now bought up more freely than of old; that much of this purified fat has been shipped to Holland and other butter ports for purposes of admixture; that although the monstrous newspaper nonsense about making butter from Thames mud is utterly baseless, the river Thames has borne upon its bosom many and many tons of white fried fat that has been prepared within a moderate distance of its banks. It is a significant fact, that during all last winter the usual consumption of butter was continued in London, &c., although the excessively dry summer which preceded it had decreased the English dairy produce very considerably, and had diminished the supply from other sources materially. At the present moment *fresh* butter is offered for sale in some parts of London at one shilling per pound *retail*, while the farmers are selling their produce wholesale at 1s. 4d. to 1s. 8d. This one-shilling fresh butter is quite a different article from the cheap Australian butter that has been recently imported."

"Artificial butter has a special interest and importance in connexion with this subject, for here we have an article of primary importance, which, if honestly dealt with, may become an immense blessing to mankind, especially to the poorer classes; but which otherwise may be kept in the dark, held back from its legitimate

uses, and made simply to serve as a means of fraud by the dishonest, and as an ever-irritating source of distrust and vexation between the honest dealer and his customers. While such false butter is sent away to Holland, to Ireland, &c., to be mixed with the genuine article, the shopkeeper is liable to be deceived; he may, with the best possible intentions, and in spite of every precaution, be supplying his customers with an article which is quite different from what he supposes he is selling—for in this case the analytical chemist cannot help him, whatever he may profess to do, the difference of chemical composition between the cow-butter and the mixed butter being so small as to pass beyond the reach of chemical detection."

"The remedy is simple enough. Let any enterprising capitalist connected with the trade commence openly and fairly the manufacture of artificial butter, to be made and sold as such—let him, in the first place, use materials which will not be offensive either to the imagination or the palate (such, for example, as clean and wholesome Australian mutton fat); in order to secure the confidence of the shopkeepers and the public, let him open his works to visitors just as Messrs. HUNTLEY and PALMER, Messrs. PEEK, FREAN, and Co., and other biscuit makers do: and then let him sell his butter under an honest name—and we believe that he will be able to overcome all prejudice, and in a short time do a handsome business, with good profits, and have the satisfaction of knowing that he has enabled the poor man and the poor man's child to enjoy a cheap slice of bread-and-butter, and many other luxuries of which butter forms a part, and also that he has destroyed a nefarious system of false dealing; for there is a certain peculiarity about the artificial butter which will become understood when the trade is familiar with it, and this will finally aid its detection in admixture."

"We have already given some attention to the subject, and have tasted some purely artificial butter which was really good, sweet, and pure. Bread-and-dripping are commonly given to children in lieu of bread-and-butter, and the artificial butter properly prepared is really a purified dripping of very superior quality. The artificial butter has the further advantage of not becoming rancid, however long it is kept, and thus it requires no salt. With both articles *honestly* placed before the purchaser—viz., the dairy butter and the butter made from animal fat—he could choose which he preferred, and pay the fair value of either."

STATEMENT of the QUANTITY and VALUE of BUTTER imported from the UNITED STATES, BELGIUM and FRANCE; and of CHEESE imported from the UNITED STATES, 1864-70.

UNITED STATES				
Years.	BUTTER.		CHEESE.	
	Quantities.	Computed Real Value.	Quantities.	Computed Real Value.
	Cwts.	£.	Cwts.	£.
1864 ..	142,672	780,024	466,988	1,213,890
1865 ..	83,216	437,703	442,913	1,296,204
1866 ..	16,059	77,754	415,726	1,386,447
1867 ..	39,035	113,290	526,740	1,470,017
1868 ..	7,117	37,279	489,117	1,439,380
1869 ..	17,203	84,603	487,870	1,612,325
1870 ..	16,915	80,928	555,385	1,861,263

Years.	BELGIUM.		FRANCE.	
	BUTTER.		BUTTER.	
	Cwts.	£.	Cwts.	£.
1864 ..	81,575	470,167	163,020	858,793
1865 ..	70,619	433,179	353,115	1,867,085
1866 ..	76,667	426,712	452,196	2,276,493
1867 ..	80,754	470,464	450,693	2,265,147
1868 ..	70,456	405,987	393,578	2,156,824
1869 ..	85,789	481,609	407,432	2,231,450
1870 ..	84,408	516,643	289,692	1,672,899



JOURNAL  
OF THE  
ROYAL AGRICULTURAL SOCIETY  
OF ENGLAND.

---

I.—*A Review of Irish Agriculture, chiefly with Reference to the Production of Live Stock.* By R. O. PRINGLE, Editor of 'The Irish Farmer's Gazette.'

BEFORE entering into details descriptive of the different systems of farm management pursued in Ireland, more especially with reference to the breeding and rearing of live stock, it will be necessary to give some account of the material there is to work upon, namely, the different breeds of live stock existing in Ireland, and the progress which has been made towards their improvement.

CATTLE.

The Kerry is, properly speaking, the only existing native breed of cattle. There are two varieties of it, first, the true Kerry, and next, the "Dexter." The former is a light, neat, active animal, with fine and rather long limbs, narrow rump, fine small head, lively projecting eye, full of fire and animation, with a fine white cocked horn tipped with black, and in colour either black or red. Cattle of this description weigh, when fat, about 4 cwt., some even less; they fatten readily, and their beef is fine in the grain, and very rich in flavour. In quality of flesh, they resemble the finer classes of West Highlands. The cows yield rich milk, and the quantity which they give, combined with the ease with which they are kept, renders them great favourites as "fancy" cows in the case of families residing in suburban villas, and the like. The following are the dimensions of a fat Kerry cow, which was awarded a prize at a show of the Royal Dublin Society: 38 inches in height at the shoulder, 70 inches in girth, and 42 inches in length from the

top of the shoulder to the tail-head. These measurements indicate a weight of about 30 imperial stones.

The "Dexter" variety is the result of a cross, introduced about 50 years ago by a Mr. Dexter, but it is not exactly known what breed that gentleman resorted to for crossing with the Kerry. It is averred by some that the "Dexter" variety is the result of selection, and not of a cross of another breed. Be that as it may, the points of the "Dexter" variety are materially different from those of the true Kerry; for the "Dexter" has a round, plump body, square behind; legs short and thick, with the hoofs inclined to turn in; the head is heavy and wanting in that fineness and life which the head of the true Kerry possesses; and the horns of the "Dexter" are inclined to be long and straight. Strange to say, distinct as these varieties are, neither the Royal Agricultural Society of Ireland, nor yet the Royal Dublin Society, have hitherto distinguished between them. Hence they have been classed together at the Shows of these Societies, which has given rise to much confusion. The distinction, however, is made at the Shows of the County of Kerry Agricultural Society, and this example ought to be followed by other societies. Of late, breeders in Kerry have paid more attention to their native cattle than they did; they have certainly every inducement to do so, for pure bred Kerry cows and heifers command high prices. The breed was long neglected, and many of the animals still hawked through the country by jobbers, under the name of Kerries, are but poor specimens of the breed.

In the western part of Connaught the native cattle have a certain resemblance to the Kerry, but are of a coarser description. They, however, fatten readily when put on good pastures. The West Highland breed has at different times been introduced into Connaught, and cattle presenting Kyloe characteristics are frequently met with. There is a curious circumstance connected with the breeding of cattle in Connemara, a mountainous district in the west of Connaught, which may be mentioned. Cattle in an inland part of Connemara become, if kept constantly on their native pastures, affected with a disease resembling ricketts, owing, apparently, to some defect in the soil. The bones become soft, and the horns grow weak and strangely distorted; one horn, perhaps, projecting straight from the head, or drooping downwards, while the other stands upright, or projects forward, giving a strange appearance to the animal. The preventive adopted by the people of that district is to remove the cattle, when young, to pastures near the sea-coast, where they are kept for a year or so; and this change seems to counteract the weakness to which they would have been subject if they had been kept at home.

In the central parts of Ireland there was formerly a long-backed, low-set variety of cattle, known as the "old Irish" breed, and held in repute chiefly for the great milking properties of the cows. The cows were exceedingly gentle, and good milkers, but it was very difficult to fatten them. These cows were very common 30 years ago, and some traces of them are even yet to be seen, as well as of a polled variety, known in Ireland under the name of Moylé cattle. Crossing, however, is fast eradicating the last traces of these breeds; and the Kerry now remains almost the sole representative of the old native breeds of Irish cattle.

The first decided step which was taken to improve Irish cattle was the introduction of the English Longhorn. The earliest importations of that description were of the Lancashire breed; but in the hands of ordinary breeders, when dispersed through the country, they became coarse and large-boned, difficult to fatten, but growing to a great size. Their principal weight consisted chiefly in the coarser parts. Subsequently, bulls of Leicester blood, as improved by Bakewell, were imported, with great advantage to the country, as their produce fattened more readily than the other kind, and their flesh was finer in the grain, and of better quality. The improved Longhorns were also good cattle for the dairy, but the breed is now nearly extinct. The last time I remember seeing Longhorns exhibited in public was at the Spring Show of the Royal Dublin Society, in 1858, when Lord de Freyne exhibited a pair of two-year-old oxen in the fat stock classes; and so little was the breed known then that I recollect some persons present inquiring what "foreign breed" Lord De Freyne's bullocks belonged to.

The Shorthorn breed was introduced into Ireland at least 60 years ago, but a considerable time elapsed before it was fully established in the country. Dubourdiou states in his "Statistical Survey of Antrim," which was published in 1812, that "a few years ago Sir Henry Vane brought a bull and some cows from Durham to Glenarm: they were of the Shorthorned breed, from Colling; they were large and well-shaped, of a fine deep-red colour, mixed with white, but reckoned too heavy for general use, though the soil about Glenarm Castle, where I saw them, was fit for beasts of very great size; but the climate, I have heard, did not agree with them, and they have been sent back." At the Show of the "Farming Society of Ireland," held at Ballinasloe, October 5th, 1812, prizes were offered for the best and second best "Teeswater, Durham, or Holderness" bulls; two, three, and four-years-old respectively. For two-year-olds there was "no claimant;" in the three-year-old class one entry,

and in the four-year-old class also one entry. Four two-year-old heifers were entered; two three-year-old heifers, and two cows, being altogether ten animals of the "Teeswater" breed, at a Show of what was at that time the national agricultural society of Ireland. It is worth while preserving the names of those early pioneers of Shorthorn breeding in Ireland. The exhibitors of bulls were the Hon. Sir Thomas G. Newcomen, Bart., and the Hon. and Rev. Dean Bourke. Of heifers and cows, W. G. Adamson, Travers Adamson, John Trench, and Sir Thomas Newcomen. At the Dublin Spring Show of the "Farming Society of Ireland," in 1813, three "Teeswater" cows were exhibited in the fat class, not one of which was successful. What a contrast to this is presented by the Spring Shows of the Royal Dublin Society at the present day, where, as was the case last Easter, 253 Shorthorns were exhibited in the classes of breeding stock, irrespective of animals, more or less pure, exhibited as fat stock.

Notwithstanding the strong feeling which existed in Ireland in favour of the Longhorn breed, the rival Shorthorns continued to be quietly imported into the country. But it was the Chilton sale, held on the 1st of September, 1829, that gave the first real impetus to Shorthorn breeding in Ireland. The "Irish Contingent" mustered strong at Chilton, and a considerable number of the animals were purchased by Messrs. Adamson, Holmes, La Touche, Archbold, Cusack, O'Farrell, and Cassidy. Mr. La Touche became the owner of "Monarch," and Mr. Holmes purchased "No. 1," by "Cato" (119), then eight years old, for 130 guineas, and her yearling daughter "Victoria," by "Satellite" (1420), for 125 guineas. Mr. Holmes became also the owner of Mason's "Britannia," by "Monarch." "Victoria" and "Britannia" were descended from "Lady Maynard," whose blood did much to establish the reputation of both Charles and Robert Colling. From Mr. Holmes's purchases at the Chilton sale originated the "Victoria" and "Britannia" tribes, for which his herd was long famous, and the blood of which we now find scattered throughout the kingdom. The late Mr. Fox, of Foxhall, the late Mr. A. H. C. Pollock, of Mountainstown, and others, also introduced Shorthorns of Mason blood into Ireland, from the herds of the late Captain Barclay, of Ury, and those of other breeders, so that Mason blood is the foundation of many of the best tribes of Shorthorns at present in the country. Of that line the famous bull "Bolivar" was a notable illustration. For a number of years "Booth" blood has been the favourite line with Irish breeders, and there are few herds of any repute in the country where it is not prominent. This has been in a great measure owing to the regular importation of stud

bulls from Killerby and Warlabý by the late Mr. Thomas Barnes, of Westland, County Meath, and his neighbour and friend Mr. Richard Chaloner, of Kingsfort ; and also by Mr. Grove, of Castle Grove, County Donegal ; Mr. Bolton, of County Wexford ; Mr. Welsted, of County Cork, and other breeders. For example, Messrs. Barnes and Chaloner have used conjointly in their herds the following "Booth" bulls :— "Roseberry" (5011), "Hamlet" (8126), "Royal Buck" (10,750), "Baron Warlabý" (7813), "Hopewell" (10,332), "Windsor" (14,013), "Sir Samuel" (15,302), "Harbinger" (10,297), "British Prince" (14,197), "Prince of Warlabý" (15,107), "British Flag" (19,351), "General Hopewell" (17,953), "Ravenspur" (20,628), "Royal Sovereign" (22,802), and "King Richard" (26,523). The Killerby and Warlabý bulls used by Mr. Grove have been "Prince Arthur" (13,497), "King Alfred" (16,334), "King Arthur" (13,110), "War Eagle" (15,483), "Sir Roger" (16,991), "Elfin King" (17,796), "Sir James" (16,980), "British Crown" (21,322), "The Sutler" (23,061), "Great Hope" (24,082), "England's Glory" (23,889). Other breeders have also hired bulls from Warlabý, and these, with bulls of the same line bred by Mr. Torr, Lady Pigott, and others, have filled Ireland with "Booth" blood, through the medium of the spring show of the Royal Dublin Society, which is regarded as a mart for the sale of young bulls of the Short-horn breed. Shorthorns of the "Bates" strain are rarely met with in Ireland.

A herd of Herefords has long been kept up by the Reynell family, at Killynon, County Westmeath, and many of the cattle in that part of the country, belonging to ordinary farmers, show their descent from that breed. Of late years a number of Herefords have been imported from some of the best herds in England by Messrs. Kearney, Reynell, the late J. O. G. Pollock, and Samuel Gilliland, of Londonderry ; but Herefords do not appear to gain ground, although the breed is much esteemed by Irish graziers. The same may be said of Devons, which were more numerous in Ireland many years ago than they are at the present day.

Polled cattle of the Scotch breeds have been bred by various gentlemen in Ireland at different times, but Mr. Owen, of Blesinton, County Wicklow, is the principal breeder of cattle of that kind at present. Mr. Owen was led into breeding polled cattle from having to do with small farmers who hold mountain farms at an elevation of 1000 to 1200 feet above the sea. At first Mr. Owen supplied them with Shorthorn bulls, but it was found that Shorthorn crosses at such an elevation, and with the poor keep which was given them, turned out to be mere runts, of comparatively little value. It struck Mr. Owen that the Galloway

breed would answer better, and he accordingly commenced with it, but has latterly used Angus bulls. The result has been that the tenants on the estate are much satisfied with the cross of the polled bulls on their small cows, as it produces nice hardy cattle, which fatten readily when put on fair pastures, making good beef, and therefore much liked by the butchers. The crosses weigh about 40 stones imperial, when  $2\frac{1}{2}$  or 3 years old, whereas the cows which produce them rarely exceed 32 stones imperial when fat. The success which has attended Mr. Owen's use of polled bulls for the improvement of cattle in mountain districts, should stimulate others who are similarly situated to follow his example.

The Ayrshire breed exists chiefly in Ulster and in the County of Cork. Some have crossed the Ayrshire with Shorthorn bulls, and have thus given size without materially lessening the value of the breed for dairy purposes. Those who follow this system do not approve, however, of going beyond the first cross. A gentleman who has had considerable experience in Ireland, of crossing the Ayrshire with the Shorthorn, told me that he found the milk of the cross-bred cows produced more butter than that of the pure Ayrshire, but that the latter produced most cheese.

A breed of cattle called the "Dutch" is found in the county of Cork, where it is much esteemed for its milking properties. The cattle are large-framed animals, with somewhat of the Shorthorn cast about their head as well as in other points. The colours are black and white, the latter not in spots but in decided patches, extending generally from side to side; just as if a white cloth had been thrown over a black animal. The cows give from 24 to 30 quarts of milk daily, of fair quality in point of richness.

Such is a brief sketch of the history of cattle-breeding in Ireland; and, from what has been stated, it will be seen that Irish cattle are now, for the most part, allied to the Shorthorn breed. This alliance has, of course, led to a material improvement in Irish cattle, but there still remains much to be done in that respect. One of the greatest obstacles is the use of cross-bred bulls. These bulls are got cheap, that is, they cost little money, while in reality they are dear at any price; and, when let to cows, only a shilling or two is charged for their services. Hence it is not unusual to find farmers losing a day's work of a man by sending him with a cow to a bull, for which eighteen-pence or two shillings are charged, rather than use a well-bred animal at their own door, because they would have to pay perhaps five or ten shillings for his service. They do not take into account that the calf of the well-bred bull will, when a year old, be worth double the value of the calf got by the mongrel sire. They only

look at the immediate outlay, and thus, notwithstanding the good Shorthorn blood which has been widely disseminated throughout Ireland during the last twenty years, a large number of unthrifty animals are still bred in the country and exported to England as store beasts. It should therefore be the object of all farming associations in Ireland, and of all landed proprietors who are willing to promote the prosperity of the country, to discourage by every means the retention of cross-bred males as stock-getting bulls. It is impossible to estimate the loss sustained by the nation at large from the use of such bulls; and it would be a positive blessing to the country if there existed some authority possessing the power to have all cross-bred mongrel bulls rendered harmless. It is only right, however, to say that many landed proprietors in Ireland have evinced a laudable desire to further the improvement of the cattle bred on their estates. They have purchased first-class bulls, which have been placed at the disposal of their tenants; some keep select breeding herds of Shorthorns, and by distributing the bull calves at nominal prices, aid materially in diffusing good blood. Where such steps have been carried on systematically for a number of years a vast improvement has taken place in the character of the cattle bred, even by the smallest class of landholders. This is a kind of estate improvement which may be effected with comparatively little outlay, while it is at the same time very remunerative, for it puts the farmers in possession of a saleable class of stock.

#### SHEEP.

The Irish native breeds of sheep are of an inferior description, and the Kerry may be taken as an illustration. These sheep are thin on the back and narrow in front, but when the widders are kept until they are four years old, and fed on fair pasture for twelve months previous to being slaughtered, they are full of fat, and their mutton is much prized on account of its delicacy. A flock of Kerry sheep presents none of the characteristics of a well-bred variety. There is considerable dissimilarity in the countenance; some are tolerably wide in the skull, but in general they are narrow in that point. Some are covered over the skull and brows with wool, like a Merino, while others are quite bare. Some are short-legged, but the majority are the reverse; and some, but not all, have horns. There are also black-nosed and white-nosed varieties; those having black noses are considered the best, whilst those with white noses are soft and inferior. Their breeders evidently do not apply the principle of selection to the breeding ewes and rams.

A great change has been effected in the breed of sheep known

as the “Roscommon” since Culley wrote, nearly eighty years ago, as follows respecting them:—

“I am sorry to say I never saw such ill-formed, ugly sheep as these: the worst breeds we have in Great Britain, are by much superior. One would almost imagine that the sheep breeders in Ireland have taken as much pains to breed plain, awkward sheep, as many people in England have been to breed handsome ones. I know nothing to recommend them, except their size, which might please some old-fashioned breeders, who can get no kind of stock large enough. But I will endeavour to describe them, and leave my readers to judge for themselves. These sheep are supported by very long, thick, crooked, grey legs: their heads long and ugly, with large, flagging ears, grey faces, and eyes sunk; necks long, and set on below the shoulders; breasts narrow and short, hollow before and behind the shoulders; flat-sided, with high, narrow, herring backs; hind quarters drooping, and tail set low. In short, they are almost in every respect contrary to what I apprehend a well-formed sheep should be; and it is to be lamented that more attention has not been paid to the breeding of useful stock in an island so fruitful in pasturage as Ireland.”

But even at that time, a beginning had been made in the way of improvement, and Culley records the fact that “Mr. French and other spirited breeders” of Roscommon, “have at very great expense and hazard imported bulls, tups, and stone horses from England, and very great improvements have already been made from these crosses. I saw,” he goes on to say, “some of the descendants of these sheep at the above fair (Ballinasloe), and it is both extraordinary and pleasing to see how much they exceeded the native breed.” Culley refers to the great “hazard” which Irish breeders of that day incurred in importing live-stock from England. The fact is, that very stringent laws existed at that time against the exportation of live stock from any part of Great Britain to Ireland, so that Irish breeders had to resort to smuggling stock into the country at great risk, before they could become possessed of an English ram, an English bull, or an English stallion. Culley refers to this fact in the following terms:—“But a very great bar is put in the way of these islanders to the improvement of their sheep; the same law is in full force against exporting sheep into Ireland as into France, or to any of our national enemies on the continent. I think it is a real hardship that this division of his Majesty’s subjects cannot have the benefit of improving their breed of sheep, without smuggling them over. Application was made to Lord Harcourt, when Lord Lieutenant of Ireland, for leave to send rams over to Ireland from England, offering very high security, three or four times the value of the ram, for his being returned to England, or,



in case of death, a proper certificate to be produced along with his skin, ear-marks, &c., but without effect." Culley then shows that it was not the fault of Irish breeders that their sheep were not improved, as he states they were "exceedingly desirous to improve their breeds of stock by the help of those from this island (Great Britain), even at an expense that many of our breeders in Great Britain would grumble at;" and in proof of this, he gives the following prices obtained for some English sheep which had been smuggled over, and which "were sold by auction in small lots at Ballinasloe fair, on the 5th of October, 1770:"—

	£	s.	d.
66 Ewes .. .. .	1094	5	5
9 Rams .. .. .	352	12	6
5 Ram lambs .. .. .	29	0	1½

He goes on to say that "one of these rams was sold to Colonel Perse at 52 guineas; two ewes to John Bodkin at 46 guineas; 2 ditto to Colonel Perse at 40 guineas; 2 ditto to Mr. Blake at 40 guineas."

The breeders in Roscommon have long since completely altered the character of their sheep, from the description given of them by the acute and experienced Northumberland farmer, who visited Ballinasloe eighty years ago. This they have done, chiefly by the introduction of Leicester blood, and by careful selection, which after all is one of the main points to be observed in the improvement of any class of live stock. The English Leicester is still resorted to as a corrective, when a flock shows any tendency to breed back to the coarse original type. They have therefore succeeded in establishing what must be reckoned a distinct breed of sheep, which is now recognised by the Irish Royal Societies as such, and which called forth a warm eulogium from Mr. Clare Sewell Read, M.P., on the occasion of that gentleman's visit to Roscommon, during the show of the Strokestown Farming Society, in September, 1869. On that occasion Mr. Read said—"I am edified by what I have this day seen and learned of Irish sheep and stock. I saw this day such sheep as I never saw before, distinct in their type from all sheep I ever saw before, with heavy fleeces of silky wool, large meat-producing frames, such as cannot be equalled without artificial feeding, and combining with these great perfections, very early maturity. In all these views I have the full concurrence of my friend Mr. Pell—an authority, I can assure you, of no small weight on such subjects. We might as well say in England that Lincolns are Leicesters, and not a pure and distinct type, as deny the splendid Roscommons their class in any show, honoured, I will say, by their exhibition."

Mr. Read's description of the Roscommon sheep is very different from that given by Culley, but the latter only saw the ungainly, unimproved animal, while Mr. Read saw the breed in its improved state. Mr. Read's remarks refer, of course, to the best form of Roscommon sheep, for there are still many sheep bred in Connaught, and shown annually at Ballinasloe Fair, which do not come up to it, notwithstanding the improvement which has undoubtedly been made in the breed of late years.

The Leicester was the first great improver of Irish sheep. There are not many flocks in the country which, strictly speaking, can be called pure, but Leicesters have been long and extensively used for crossing the native breeds, and it is in this way that improvement has been chiefly effected. Mr. William Owen, County Wicklow; Mr. Meade, County Cork; Mr. Massey, County Cork; Sir Allan Walsh, and Mr. Seymour Mowbray, Queen's County, are among the leading breeders in Ireland who have pure Leicester flocks, founded chiefly on Pawlett, Sanday, and Inge blood. English breeders, such as Mr. Turner and others, send over annually a number of rams, which are either sold by auction at the great ram sales in September, or privately by agents.

Of late years a large number of rams of the Lincoln breed have been imported into Ireland; but latterly, Lincolns appear rather to have fallen off in public favour. Mr. Caleb Going, County Tipperary, is the principal breeder of this class of sheep, the blood being derived direct from some of the best flocks of the kind in England.

Another breed which has been introduced at a comparatively recent date is the Border Leicester, or that type of Leicester which prevails in Northumberland and the Border counties of Scotland. These sheep are longer in the body than the English Leicester, and have generally better quarters and thighs, but many of them are deficient in the neck. Their wool is good, but frequently inclined to be bare underneath. They are hardy, prolific, and answer well for crossing, imparting to the crosses early maturity and good quality of flesh. From the demand which has existed for sheep of this kind, it frequently occurs that the first cross of them with ordinary ewes are put forward under the name of Border Leicesters, and sold as such; but those crosses are easily distinguished by any one who knows the characteristics of a true Border sheep. The district where those sheep are chiefly bred in Ireland are Queen's County, Kildare, and County Kilkenny. The Royal Agricultural Society of Ireland, and the Royal Dublin Society, have assigned separate classes at their shows for the English Leicester and the Border Leicester, which has prevented the confusion, and, perhaps, a

certain amount of jealousy, which arose out of the awards when both kinds were exhibited in one class.

Fifteen years ago very few Shropshire Downs were to be found in Ireland, but since that time the breed has become well known and much appreciated in the country. This has been partly owing to the enterprise of Mr. C. W. Hamilton, of Hamwood, County Meath, who has established a flock of Shropshire Downs which may fairly rank with any in England. In fact, rams are frequently purchased at Mr. Hamilton's annual sales by English breeders. The intrinsic merits of the breed have also exercised a considerable influence in diffusing it through many parts of Ireland. Shropshire Down rams are found admirably adapted for crossing with ordinary ewes, more especially for the production of butcher's lambs. The lambs of a cross of this kind weigh heavily for their size. The late Mr. Naper, Loughcrew, County Meath, showed what using well-bred Shropshire rams for crossing very inferior ewes will effect. The ewes selected by Mr. Naper were the Scotch blackfaced, which cost him from 14s. to 17s. each. The lambs produced by that cross of the Shropshire brought more than double the price of their dams when sold as lambs to the butcher; and when retained until they became two-shear sheep, became heavy sheep, taking usually the first prizes in their class—that of crosses of any kind—at the Christmas shows of the Royal Dublin Society, and realising, even when prices were lower than they have been for some time past, from 4*l.* to 4*l.* 10s. each. The wool of the cross is also so much improved, compared with blackfaced wool, that it brings within a very little of the price of pure Shropshire wool.

Southdowns may be considered as unknown in Ireland. Some gentlemen may have a few about their places as fancy sheep, for table use, but no ordinary breeder ever thinks of turning his attention to them. Cotswold rams were much used some years ago, but comparatively few persons use them now, although some of the Connaught flocks show traces of the blood in the characteristic tuft on the brow.

After the "famine years" of 1846-48, consequent on the great failure of the potato, large tracts of land were left waste in the west of Ireland, and when matters began to improve a few years later, the owners of these tracts, wishing to turn them to some useful purpose, imported large numbers of Cheviot and blackfaced sheep from Scotland. The importation of sheep, at least on a large scale, ceased about 1854; but every year ewes continue to be brought over, especially to the northern counties. Sheep-farming on a large scale, as practised in Scotland, has been

introduced into Donegal, Connemara, and other mountainous parts of the west of Ireland. The flocks consist of the Cheviot and also of the blackfaced breed. I consider the latter much better adapted than the Cheviot breed for Irish mountain pastures, as these lack the grassiness of the Scotch mountains, and are also of a more spongy nature, which even surface-draining does not always counteract, although it certainly effects a vast improvement in the nature of the pasture. Having at different times seen crosses produced by the Lonk ram with the Scotch blackfaced ewe, exhibited at shows of the Highland and Agricultural Society—more especially at the Stirling meeting in 1864 and the Inverness meeting in 1865—I am of opinion that a similar cross deserves to be taken into consideration by those who have blackfaced flocks in Ireland. The wool of the Lonk cross is much superior in quality, and I might almost say weight, of fleece, to that of the blackfaced breed, while the cross is equally hardy, and loses nothing of the rich flavour which distinguishes blackfaced mutton. I have seen some extraordinary specimens of Lonk wedders exhibited by Mr. Jonathan Peel, at the London Christmas Club Shows, which seemed to indicate that the Lonks are more inclined to early maturity than the Scotch blackfaced breed. These are all considerations of importance, and worth testing in actual practice.

When we examine the description of sheep found in possession of the ordinary class of farmers on the arable lands of Ireland, we find that they are for the most part inclined to be coarse, and there is a want of quality and “character” about them. There is no better index to the character of a sheep, or, in fact, of any animal, than the head, and in the heads of the common class of sheep in Ireland there is frequently a certain degree of “sourness,” which indicates an animal deficient in the desirable quality of early maturity. The want of “character” is shown by the dissimilarity which exists even in the same flock; and it need scarcely be said that a strong family likeness is certain proof that a good system has been followed in breeding the flock. This want of character I am inclined to attribute in a great measure to neglect of proper selection, extending not merely to the rams used in the flock, but also to the ewes retained for breeding. There is also another reason, namely, a frequent and often injudicious intermingling of blood. For instance, a person who has been in the habit of using a common ram, descended in some degree from the Leicester breed, sees in the papers a letter recommending the Lincoln, and he forthwith gets a Lincoln ram. After using him for a time, the great size of some show Cotswolds attracts his attention, and he gets a Cotswold; and in this way

the flock, which had no decided character at first, becomes thoroughly mongrel. I have known strangers, practical men of large experience in their own country, who, on visiting Ireland for the first time, and looking from the windows of a railway carriage, have expressed an opinion that Ireland is not suited for the breeding of sheep. This is an erroneous conclusion. There are, of course, tracts of wet bottom lands which are unfit for sheep pasture; but a large proportion of the sheep lands in Ireland are dry limestone soils. There is abundance of practical proof, also, that the climate is not unfavourable to sheep-breeding. Want of good management may, and undoubtedly does, exist in many instances, and that of itself is a serious drawback; but the physical characteristics of Ireland are favourable, rather than otherwise, to the breeding of sheep.

#### SWINE.

Any review of Irish live stock would be incomplete without a notice of this class. The Irish Agricultural Returns for 1871 state that there are 1,614,190 pigs in Ireland; and as they are chiefly in the hands of small farmers, they form, for various reasons, an important item in the live stock of the country.

The old Irish, or "greyhound pigs," were "tall, long-legged, bony, heavy-eared, coarse-haired animals, their throats furnished with pendulous wattles, and by no means possessing half so much the appearance of domestic swine as they did of the wild boar, the great original of the race."\* These swine were remarkably active, and, it is said, could "clear a five-barred gate as well as any hunter," but they are now practically extinct. In a few remote parts some traces of the breed may occasionally be seen, but even those instances are becoming rarer every year, from the almost universal diffusion of improved breeds.

The Berkshire is the favourite breed in Ireland. Yorkshire pigs have also their advocates, and so also has a cross of the York and Cumberland varieties, which succeeds very well; but Berkshire blood predominates, and one is often surprised to find excellent pigs of that breed in places and districts where their appearance is quite unexpected. Irish farmers find the Berkshire a hardy, easily kept, and generally useful breed; and its general diffusion throughout the country is owing to the circumstance that most of the resident gentry have Berkshire breeding sows in their farmyards, the produce of which are disposed of on moderate terms to the country people. The Berkshire department of the shows of the Royal Agricultural Society of England have been drawn

---

\* Richardson, 'On the Pig.'

upon for years to supply the best blood for the use of Irish breeders; and now Irish breeders are in a position to meet their English friends on English ground. This was shown to be the case at the late Royal Show at Wolverhampton, where Lord Clermont's very handsome young Berkshire sow, bred in Ireland, was awarded the second prize in an excellent class, and was sold on the ground, at 40*l.*, to a Canadian breeder. Lord Clermont has taken a leading part, for many years, in breeding Berkshires, sparing no expense in procuring the best blood that could be obtained, and having the details of management conducted with great skill and judgment.

#### POULTRY.

This is a department of some importance, more especially to small farmers. The Agricultural Returns state that there are upwards of eleven million head of poultry of all kinds in Ireland, which may be taken as representing a value of at least half a million sterling, irrespective of the produce in eggs, of which large quantities are annually exported to Great Britain. I do not find, however, in those statistical returns which have been published, relating to the commerce of Irish agriculture, any statement which shows the actual extent of the trade in poultry and eggs between Ireland and England, but, as an illustration of its extent, it may be stated that the value of the weekly exports of fowl from the port of Waterford alone exceeds 1000*l.* Annual fairs are held in different parts chiefly for the sale of geese and turkeys. These are purchased from the breeders and fattened for market on other farms, or exported direct to England to be fed there. The weekly markets held in the different towns throughout the country are all well supplied with fowls and eggs, which are bought up for exportation; and in the most remote parts, in Connemara for instance, heaps of egg-boxes and crates may be seen at the door of every little shop waiting to be filled for the English market. At one time previous to that great era in the social history of Ireland, "the famine years" —1846 to 1848—a Connemara woman would have been ashamed to let it be known that she sold eggs, but that feeling has become extinct since the competition for supplying England has raised the value of eggs more than six hundred per cent., compared with what it formerly was. The small farmers usually keep their fowls in the same house with themselves, where the fowls roost on the rafters; and although this is a system of management which is by no means conducive to the comfort of the human inmates, it certainly is favourable for their feathered companions, who repay it by earlier and more regular laying than would be the

case if the fowls were housed in sheds or other cold buildings. Agricultural shows have tended to diffuse good breeds of poultry through the country. Dorking and Spanish fowls are the favourites, wherever a distinct breed has found its way.

### THE STATISTICS OF IRISH AGRICULTURE.

The condition of the country with respect to the production of live stock is shown in the Annual Returns collected by the Registrar-General for Ireland. The collection of agricultural statistics has been carried on for a much longer time in Ireland than has been the case in Great Britain. The enumeration of live stock was first attempted by Government in 1841. Nothing further was done, however, until 1847, when an inquiry of a similar kind, including crops, &c., was again instituted, and has since been carried on from year to year. The returns taken in 1841 are generally regarded as forming a basis of comparison, but there is good reason to believe that the agricultural statistics collected at that time were far from being correct. The people regarded the inquiries made with respect to the number of cattle, &c., which they had, as being a preliminary step to the imposition of some unknown tax, or to an increase of their rents; and, in the generality of instances, the numbers given to the enumerators did not much exceed one-half of what actually existed at the time. The enumeration taken in 1847 represents the country when in its worst state from the effects of the "famine years," and those effects continued to keep the number of live stock in Ireland low until 1851-52, when matters began to amend.

In estimating the value of live stock, the average rates per head assumed by the Census Commissioners in 1841 are still retained. This is done simply for the purpose of comparison, for the average rates assumed at that time are much below the rates which prices of late years would warrant. Thus, horses and mules were valued at 8*l.* each; asses at 1*l.*; horned cattle at 6*l.* 10*s.*; sheep at 1*l.* 2*s.*; pigs at 1*l.* 5*s.*; goats at 7*s.* 6*d.*; and poultry at 6*d.* per head. These rates, therefore, continue to be the basis upon which the total value of Irish live stock is estimated from year to year.

As subsistence should precede stock, the following Tables, as given in the Reports of the Registrar-General, will show how matters stand in this matter; namely, the extent under each of the principal crops—the *estimated* total produce, and the average yield per statute acre for all Ireland, in each year from 1851 to 1870, inclusive:—

TABLE I.—EXTENT UNDER CROPS IN STATUTE MEASURE.

Years.	Wheat.	Oats.	Barley.	Bere.	Rye.	Potatoes.	Turnips.	Mangel- wurzel.	Cabbage.	Flax.	Hay.
	Acres.	Acres.	Acres.	Acres.	Acres.	Acres.	Acres.	Acres.	Acres.	Acres.	Acres.
1851	504,248	2,189,775	282,617	53,347	19,697	868,501	383,548	25,847	28,962	140,536	1,246,408
1852	353,566	2,283,449	249,476	40,933	12,993	876,532	356,790	30,830	28,452	137,008	1,270,713
1853	326,896	2,157,849	272,644	28,380	12,376	898,733	399,377	33,283	28,421	174,579	1,270,742
1854	411,284	2,045,298	236,293	16,920	11,366	989,660	329,170	21,551	26,758	151,403	1,257,864
1855	445,775	2,118,858	226,629	11,185	11,632	982,301	366,953	22,339	24,121	97,075	1,314,807
1856	529,050	2,037,437	182,796	6,554	13,337	1,104,704	354,451	22,071	27,968	106,311	1,302,787
1857	559,646	1,980,934	211,288	6,026	15,348	1,146,647	350,047	21,449	30,011	97,721	1,369,892
1858	546,964	1,981,241	190,768	5,002	11,470	1,159,707	338,202	29,547	33,132	91,646	1,424,495
1859	464,175	1,982,662	177,894	3,751	9,447	1,200,347	322,137	26,906	31,680	136,282	1,437,111
1860	466,415	1,996,304	181,099	3,057	9,677	1,172,079	318,540	31,986	22,785	128,595	1,594,518
1861	401,243	1,999,160	198,955	3,052	8,530	1,133,504	334,104	22,833	30,020	147,957	1,546,206
1862	356,321	1,977,528	192,302	2,910	9,213	1,018,112	376,715	23,114	30,543	150,070	1,552,924
1863	260,311	1,953,883	171,892	2,730	5,929	1,023,414	351,436	16,320	34,125	214,099	1,560,638
1864	276,483	1,814,886	172,700	2,862	6,032	1,039,724	337,355	14,073	31,821	301,693	1,609,569
1865	266,989	1,745,228	177,102	2,913	7,178	1,066,260	334,212	14,389	33,622	251,433	1,678,493
1866	299,190	1,699,695	150,293	2,227	7,794	1,050,353	317,198	20,082	36,531	263,507	1,601,423
1867	261,034	1,660,511	171,001	1,931	7,671	1,001,781	335,728	18,739	24,018	253,257	1,658,335
1868	285,150	1,701,645	186,318	2,014	7,892	1,034,681	320,094	19,031	32,875	206,483	1,692,135
1869	280,460	1,685,240	221,710	2,401	8,782	1,041,902	322,072	21,050	32,265	229,252	1,670,716
1870	259,847	1,650,039	241,284	2,475	9,322	1,043,583	339,059	25,320	34,979	194,910	1,772,851



TABLE II.—ESTIMATED TOTAL PRODUCE.

Years.	Wheat.	Oats.	Barley.	Berc.	Rye.	Potatoes.	Turnips.	Mangel-wurzel.	Cabbage.	Flax.	Hay.
1851	Quarters. 1,493,525	Quarters. 10,771,236	Quarters. 1,375,518	Quarters. 286,149	Quarters. 97,187	Tons. 4,441,922	Tons. 6,081,326	Tons. 466,235	Tons. 401,622	Tons. 83,861	Tons. 2,518,977
1852	1,154,205	11,719,528	1,257,398	231,075	63,289	4,255,604	5,675,897	357,139	404,680	35,462	2,690,598
1853	1,133,585	10,690,881	1,398,705	153,765	62,284	5,741,538	6,562,471	588,988	401,828	43,863	2,518,984
1854	1,452,467	11,293,101	1,212,047	89,066	55,687	5,061,654	5,207,636	366,427	356,649	35,606	2,494,951
1855	1,520,819	10,266,350	1,097,631	56,848	57,362	6,235,281	6,073,598	402,958	312,928	23,428	2,662,046
1856	1,629,963	9,236,869	757,536	32,773	44,520	4,408,543	4,581,172	287,838	332,650	18,791	2,492,732
1857	1,662,957	8,895,347	848,783	28,553	49,252	3,509,344	4,360,197	298,515	327,875	14,475	2,566,644
1858	1,746,464	8,953,541	802,028	24,866	35,858	4,892,225	4,364,788	404,423	381,484	17,583	2,701,006
1859	1,468,475	8,170,856	694,004	18,111	27,792	4,329,523	3,462,071	307,946	329,997	21,577	2,321,779
1860	1,271,588	8,841,924	750,245	14,113	27,896	2,741,380	2,627,978	290,241	188,711	23,760	3,206,402
1861	851,871	8,045,689	685,381	12,531	22,626	1,858,433	3,392,884	235,639	310,307	22,568	2,810,352
1862	683,048	7,283,400	661,833	11,537	21,208	2,148,402	3,792,682	221,678	256,425	24,253	2,781,529
1863	837,906	8,928,671	758,529	13,966	15,495	3,445,949	4,183,672	185,222	342,412	42,646	2,762,033
1864	875,782	7,826,332	761,909	15,160	12,680	4,312,388	3,467,659	147,284	297,375	64,506	2,607,153
1865	826,783	7,659,727	732,017	13,989	18,364	3,865,990	3,801,683	191,937	350,252	39,561	3,068,707
1866	805,710	7,284,835	654,980	11,016	19,721	3,068,594	3,786,462	250,322	382,363	40,991	2,878,622
1867	725,847	7,435,535	742,487	9,705	19,231	3,147,458	3,909,600	238,737	226,185	35,397	3,070,160
1868	945,818	7,628,857	884,753	10,571	21,187	4,062,207	3,514,406	244,892	320,395	24,987	2,871,039
1869	796,222	6,973,173	952,683	12,388	22,382	3,372,433	3,964,672	263,200	310,075	29,569	3,039,709
1870	754,261	7,559,303	1,034,060	12,202	26,078	4,218,445	3,941,402	321,568	342,713	30,771	3,385,444

TABLE III.—ESTIMATED AVERAGE PRODUCE PER STATUTE ACRE.

Years.	Wheat.	Oats.	Barley.	Bere.	Rye.	Potatoes.	Turnips.	Mangel-wurzel.	Cabbage.	Flax.	Hay.
1851	Cwts. 8 Stones. 12·5	Cwts. 8 Stones. 13·8	Cwts. 8 Stones. 17·6	Cwts. 8 Stones. 16·6	Cwts. 8 Stones. 20·0	Tons. 5·1	Tons. 15·9	Tons. 18·0	Tons. 13·9	Stones. 14 lbs. 38·6	Tons. 2·0
1852	13·8	14·4	18·2	17·4	19·8	4·8	15·9	18·1	14·2	41·4	2·1
1853	14·5	13·8	18·6	16·8	20·5	6·4	16·4	17·7	14·1	40·2	2·0
1854	14·8	15·4	18·6	16·2	19·8	5·1	15·8	17·2	13·3	37·6	1·9
1855	14·3	13·7	17·4	15·6	20·0	6·4	16·6	18·0	13·0	38·6	2·0
1856	13·0	12·8	15·0	15·4	13·5	6·0	12·9	13·0	11·9	28·3	1·9
1857	12·5	12·6	14·6	14·6	13·0	3·1	12·5	13·9	10·9	23·7	1·9
1858	13·5	12·6	15·2	15·4	12·8	4·2	12·9	13·7	11·5	30·7	1·9
1859	13·3	11·6	14·0	15·0	12·0	3·6	10·7	11·4	10·4	25·3	1·6
1860	11·5	12·6	15·0	14·2	11·8	2·3	8·3	9·1	8·3	29·6	2·0
1861	9·0	11·2	12·4	12·8	10·8	1·6	10·2	10·3	10·4	24·4	1·8
1862	8·1	10·3	12·4	12·3	9·3	2·1	10·1	9·6	8·4	25·9	1·8
1863	13·5	12·8	15·9	15·8	10·6	3·4	11·9	11·3	10·0	31·9	1·8
1864	13·3	12·1	15·9	16·4	8·5	4·1	10·3	10·5	9·3	34·2	1·6
1865	13·0	12·3	14·9	14·8	10·4	3·6	9·9	13·3	10·4	25·2	1·8
1866	11·3	12·0	15·7	15·3	10·3	2·9	11·9	12·5	10·5	24·9	1·8
1867	11·7	12·5	15·7	15·5	10·2	3·1	11·6	12·7	9·4	22·4	1·9
1868	13·9	12·5	17·1	16·2	10·9	3·9	11·0	12·9	9·7	19·4	1·7
1869	11·9	11·6	15·5	15·9	10·6	3·2	12·3	12·5	9·6	20·6	1·8
1870	12·2	12·8	15·5	15·2	11·3	4·0	11·6	12·7	9·8	25·3	1·9

There are certain points brought out in these Tables which deserve consideration as illustrating certain features of Irish agriculture. (1.) The decrease which has taken place in all the cereal crops, even in oats, the staple cereal crop of Ireland. (2.) The increase in the cultivation of potatoes, owing to the comparative freedom from disease which the crop has shown for several years, and to the fact that so large an extent of the land in cultivation is in the occupation of holders of small farms (as will be shown afterwards), to whom the potato crop is a necessity. The Irish Registrar-General includes the potato under the general head of "Green Crops," but it cannot be regarded as a cattle-feeding crop, like turnips and mangel-wurzel. A portion of the crop, no doubt, is employed in feeding pigs and poultry, but the bulk of it is used as the food of the people, for the exportation of potatoes from Ireland may be regarded as confined to the early kinds at the first of the season. (3.) It will be seen that the cultivation of turnips and mangel-wurzel does not gain ground; and the important considerations which arise out of this fact will be understood when we take into account the relation which those crops bear to the rearing and feeding of cattle and sheep. In Great Britain, 70 per cent. of the "Green Crops" are turnips and mangel; while in Ireland the proportion does not exceed  $23\frac{1}{2}$  per cent. In the case of potatoes the proportions are reversed, being 71 in Ireland against 16 in Great Britain. (4.) But it is not merely the extent devoted to the cattle-feeding crops that is unsatisfactory; it will also be seen that the actual produce of these crops has decreased, and that from the reduction in the average produce per acre, it appears that the condition of the land is not improving. Thus, the average produce per acre of the two principal cattle-feeding crops—turnips and mangel-wurzel—during the first five years given in the foregoing Tables, was as follows:—Turnips, 16·1 tons; mangel, 17·8 tons; while in the last-named five years the average produce per acre was,—Turnips, 11·6 tons; mangel, 12·6 tons. The annual average total produce of turnips and mangel during the first five years amounted to 6,396,535 tons; and during the last five years to 4,087,052 tons; being a decrease of 2,309,483 tons per annum in the amount of cattle-food produced in Ireland. The practical result of this decrease will be better understood when we consider that if a cow or ox gets half-a-cwt. of root-food—turnips or mangels—per day, from the 1st of November to the 31st of March, 75 cwts., or, say, in round numbers, four tons of such food will be consumed during that period. Consequently the decrease in the amount of root-food produced in Ireland from 1866 to 1870 inclusive, repre-

sents the loss of the winter keep of 577,370 head of cattle, as compared with the annual production of root-food during the years 1851 to 1855 inclusive; being equivalent to the loss of the winter food, or at least a considerable proportion of it—of one-seventh of the total number of cattle in Ireland at the present time. This deficiency is partly due to the fact that the extent under turnips and mangels has been less during the last five years than it was during the first five years given in the foregoing Tables; but it is also due to the decrease in the average produce per acre, which the returns show has taken place of late years; amounting, in the case of both turnips and mangels, to five tons per acre. How far this may be accounted for, by the use of inferior artificial manures, is not easily proved; but it is a fact, that certain manures, originally of a high character, frequently become much altered after leaving the wholesale agent, before the retail dealer gives them out to his customers. There is also good reason to believe that, notwithstanding the vigilance of some of the Irish agricultural societies, such as the Chémico-Agricultural Society of Ulster, the County Kildare Society, and the Queen's County Society, there is a strong trade in spurious manures carried on. Those so-called manures are imported from England, and consist largely of clay and ochre. It is the small farmers who chiefly suffer by this nefarious trade, as those who purchase largely take care to protect themselves, either by having the manures analysed, or by purchasing only from manufacturers, or wholesale agents whose characters are above suspicion. The only way in which the small farmers can be protected, under present circumstances, is for each local farming society to watch the sale of manures in its particular district, and to have samples of all doubtful manures submitted for examination by a competent analytical chemist. It is to be hoped, however, that Parliament will ultimately provide some means for preventing the manufacture and sale of adulterated manures, and of punishing those who may be engaged in the trade.

The following Tables (IV. and V.) show the manner in which the country was divided into holdings in 1869, also the area under crops, grazing-land, fallow, plantations, bog and waste, *unoccupied*, in the several classes.

These Tables throw much light on the agricultural condition of Ireland. The cultivation of crops occupies, as will be seen, a much larger per-centage of the acreage held by the small class of farmers, whilst large landholders devote more to grazing.

The next point is the enumeration of the different classes of

**TABLE IV.—QUANTITY OF LAND under DIFFERENT CROPS on the VARIOUS CLASSES of HOLDINGS.**

CLASSIFICATION OF HOLDINGS.	No. of Holdings in each Class.	Extent of Land held by each class of Landowners.	DIVISION OF LAND.					Bog and Waste.
			Under Crops.	Grazing Land.	Fallow.	Woods and Plantations.	Acres.	
Holdings not exceeding 1 acre .. .. .	49,394	24,368	Acres. 20,869	Acres. 1,466	Acres. 51	Acres. 206	Acres. 1,776	
Ditto above 1 and not exceeding 5 acres ..	75,895	269,516	169,322	75,707	270	2,610	21,607	
Ditto 5 ditto 15 ditto ..	171,699	1,794,336	844,822	778,181	1,396	10,320	159,617	
Ditto 15 ditto 30 ditto ..	137,086	3,061,993	1,231,013	1,474,822	2,750	16,148	337,260	
Ditto 30 ditto 50 ditto ..	72,511	2,927,015	1,026,279	1,487,879	3,657	20,554	388,646	
Ditto 50 ditto 100 ditto ..	55,070	4,050,737	1,164,427	2,208,041	5,597	45,096	627,576	
Ditto 100 ditto 200 ditto ..	21,876	3,287,377	695,850	1,860,915	4,480	66,936	659,196	
Ditto 200 ditto 500 ditto ..	8,210	2,810,481	356,612	1,472,636	2,116	91,208	887,909	
Holdings above 500 acres .. .. .	1,541	2,094,101	68,586	681,743	367	67,383	1,276,022	
Total .. .. .	593,282	20,319,924	5,577,780	10,041,390	20,684	320,461	4,359,609	

TABLE V.—The foregoing Table reduced to Proportions Per Cent.

CLASSIFICATION OF HOLDINGS.	Proportion per cent. of Holdings in each Class.	Under Crops.	Grass.	Fallow.	Woods and Plantations.	Bog and Waste.	Total.	Average Extent of the Holdings in each Class.
Holdings not exceeding 1 acre .. .. .	8.3	85.6	6.0	0.2	0.9	7.3	100	A. R. P. 0 1 39
Ditto above 1 and not exceeding 5 acres ..	12.8	62.8	28.1	0.1	1.0	8.0	100	3 2 8
Ditto 5 ditto 15 ditto ..	28.9	47.1	43.3	0.1	0.6	8.9	100	10 1 32
Ditto 15 ditto 30 ditto ..	23.1	40.2	48.2	0.1	0.5	11.0	100	22 1 14
Ditto 30 ditto 50 ditto ..	12.2	35.1	50.8	0.1	0.7	13.3	100	40 1 19
Ditto 50 ditto 100 ditto ..	9.3	28.8	54.5	0.1	1.1	15.5	100	73 2 9
Ditto 100 ditto 200 ditto ..	3.7	21.2	56.6	0.1	2.0	20.1	100	150 1 4
Ditto 200 ditto 500 ditto ..	1.4	12.7	52.4	0.1	3.2	31.6	100	342 1 4
Holdings above 500 acres .. .. .	0.3	3.3	32.6	0.0	3.2	60.9	100	1,358 3 28
<b>Total</b> .. .. .	100.0	27.4	49.4	0.1	1.6	21.5	100	—

live stock in Ireland. The following, therefore, is a statement taken from the Registrar-General's Returns, of the numbers of each kind of live stock in Ireland, in 1841, and in each year from 1851 to 1871 inclusive:—

TABLE VI.—ENUMERATION of the NUMBERS of DIFFERENT CLASSES of LIVE STOCK in IRELAND.

Years.	Horses and Mules.	Asses.	Cattle.	Sheep.	Pigs.	Goats.	Poultry.
1841	576,115	92,365	1,863,116	2,106,189	1,412,813	No Return.	8,458,517
1851	543,312	136,981	2,967,461	2,122,128	1,084,857	235,313	7,470,694
1852	545,900	144,120	3,095,067	2,613,943	1,072,658	278,444	8,175,904
1853	561,100	148,720	3,383,309	3,142,656	1,144,945	296,182	8,660,738
1854	564,530	150,576	3,497,901	3,722,219	1,342,549	311,492	8,630,488
1855	576,144	151,742	3,564,400	3,602,342	1,177,605	283,970	8,366,629
1856	592,868	155,224	3,587,858	3,694,294	918,525	269,746	8,908,226
1857	619,294	160,987	3,620,954	3,452,252	1,255,186	243,046	9,491,463
1858	630,611	163,323	3,667,304	3,494,993	1,409,883	228,351	9,563,185
1859	648,379	169,354	3,815,598	3,592,804	1,265,751	219,346	10,251,749
1860	639,500	167,845	3,606,374	3,542,080	1,271,072	194,465	10,060,776
1861	634,378	173,711	3,471,688	3,556,050	1,102,042	189,842	10,371,175
1862	622,589	170,887	3,254,890	3,456,132	1,154,324	175,328	9,916,630
1863	599,971	167,244	3,144,231	3,308,204	1,067,458	166,044	9,649,118
1864	582,434	169,221	3,262,294	3,366,941	1,058,480	171,307	10,424,085
1865	568,142	168,009	3,497,548	3,694,356	1,305,953	171,207	10,681,955
1866	555,647	173,175	3,746,157	4,274,282	1,497,274	186,880	10,889,747
1867	543,686	167,233	3,707,803	4,835,519	1,235,191	190,429	10,334,903
1868	544,372	169,100	3,646,796	4,901,496	869,578	199,060	10,602,782
1869	547,757	171,664	3,733,675	4,651,195	1,082,224	205,861	10,801,687
1870	532,657	171,745	3,799,912	4,336,884	1,461,215	211,035	11,159,002
1871	557,332	180,024	3,973,102	4,228,721	1,616,754	232,892	11,663,030

In order to show the manner in which the live stock is distributed among the different classes of occupiers, the following Table (VII.) is given, showing the number of holdings by classes; the total value of the live stock on each class, and the average value per holding, in 1869, being the last year for which a return of this kind has been issued by the Registrar-General:—

TABLE VII.—DISTRIBUTION of LIVE STOCK on the VARIOUS CLASSES of HOLDINGS.

CLASSIFICATION OF HOLDINGS.	Number of Holdings.	Value of Live Stock.	Average Value per Holding.
		£.	£. s. d.
Not exceeding 1 acre* .. .. .	75,341	354,086	4 14 0
Holdings above 1 and not exceeding 5 acres	75,895	619,275	8 3 2
Ditto 5 ditto 15 ditto	171,699	4,050,156	23 11 9
Ditto 15 ditto 30 ditto	137,086	6,581,600	48 0 3
Ditto 30 ditto 50 ditto	72,511	5,954,123	82 2 3
Ditto 50 ditto 100 ditto	55,070	7,582,057	137 13 7
Ditto 100 ditto 200 ditto	21,876	5,600,254	256 0 0
Ditto 200 ditto 500 ditto	8,210	3,774,068	459 13 10
Ditto 500 acres .. .. .	1,541	1,123,323	728 19 2
Total .. .. .	619,229	35,638,942	57 11 1

Tables VI. and VII. are official documents, but Tables VIII. and IX. (pp. 25 and 26), although not issued by the Registrar-General, have been compiled with great care, and are interesting as showing the value of Irish live stock during the years 1850 to 1871.

These inclusive Tables are from 'Thom's Annual Directory,' an acknowledged authority on statistics relating to Ireland, &c. It is necessary to remark that the cattle and sheep offered for sale at Ballinasloe may be regarded as chiefly consisting of store stock. They are purchased, for the most part, by graziers in Leinster, who prepare the cattle and widders for the Dublin and Liverpool markets, while the ewes are kept for producing market lambs, and are then fattened off for the butcher.

The number of cattle, sheep, and swine exported from Ireland to Great Britain in 1869, were as follows: cattle, 509,106; sheep, 1,015,694; swine, 264,620; and in 1870, cattle, 453,969; sheep, 620,834; swine, 422,076.

#### FARMS AND FARM MANAGEMENT.

The preceding Table (VII.), on this page, shows that the majority of the holdings in Ireland do not exceed 50 statute acres in extent. There are altogether 593,282 holdings, and of these no less than 506,585 do not exceed 50 acres; the total extent of land held in such farms is 8,077,228 acres; showing an average a little under 16 acres in each holding.

The medium class of holdings, or those over 50 acres and not exceeding 200 acres, are 76,946 in number, and include in extent 7,338,114 acres, being a little over 95 acres on an average.



TABLE VIII.—NUMBER OF HORNED CATTLE OFFERED FOR SALE AT THE GREAT OCTOBER FAIR OF DUBLIN, 1850 TO 1871 INCLUSIVE, WITH THE NUMBERS SOLD, AND THEIR AVERAGE PRICES, IN THE LAST 22 YEARS—1850 TO 1871 INCLUSIVE.

HORNED CATTLE.			AVERAGE PRICE OF OXEN.								AVERAGE PRICE OF HEIFERS.												
Years.	Sold.	Unsold.	Total.	1st Class.		2nd Class.		3rd Class.		4th Class.		1st Class.		2nd Class.		3rd Class.		4th Class.					
				£.	s. d.	£.	s. d.	£.	s. d.	£.	s. d.	£.	s. d.	£.	s. d.	£.	s. d.	£.	s. d.	£.	s. d.		
1850	9,395	6400	15,795	10	0	8	0	6	0	6	0	5	0	12	0	10	0	9	0	6	0		
1851	10,640	1019	11,659	10	10	8	10	6	5	0	5	5	0	13	0	10	10	9	5	0	5	15	0
1852	11,308	495	11,803	12	0	10	0	7	10	0	6	0	0	14	10	0	0	10	0	0	7	0	0
1853	10,898	1614	12,512	21	0	17	10	14	10	0	11	0	0	16	0	0	0	10	10	0	8	10	0
1854	15,570	2839	18,409	21	15	17	10	14	10	0	9	15	0	20	0	0	0	14	0	0	9	0	0
1855	18,033	4707	22,740	21	17	6	18	5	0	15	0	9	5	0	21	0	0	13	10	0	9	0	0
1856	18,685	7438	26,123	21	0	17	0	14	0	0	7	18	0	20	0	0	0	12	0	0	7	12	6
1857	18,894	1894	20,788	21	15	18	0	14	10	0	8	7	6	21	0	0	0	10	15	0	7	15	0
1858	16,569	8677	25,046	19	10	16	15	12	15	0	7	17	6	19	0	0	0	10	5	0	6	15	0
1859	14,714	3398	18,112	19	10	16	7	12	5	0	7	5	0	19	10	0	0	10	5	0	6	15	0
1860	15,745	1729	17,474	21	0	17	7	13	5	0	8	0	0	21	10	0	0	11	15	0	7	10	0
1861	16,397	2718	19,115	21	0	16	17	12	10	0	7	15	0	21	0	0	0	10	15	0	6	12	6
1862	16,206	2140	18,346	20	0	15	15	12	5	0	7	0	0	20	0	0	0	10	0	0	6	10	0
1863	17,927	4949	22,876	21	0	16	5	12	15	0	7	12	6	21	0	0	0	10	10	0	7	0	0
1864	14,545	2274	16,819	20	10	17	0	12	15	0	7	12	6	20	10	0	0	11	0	0	7	10	0
1865	16,343	1264	17,607	22	10	18	10	13	10	0	9	0	0	22	10	0	0	12	10	0	8	10	0
1866	16,695	2655	19,350	22	10	18	10	13	17	6	9	5	0	22	10	0	0	12	15	0	8	12	6
1867	17,547	6187	23,734	22	7	18	10	14	0	0	9	0	0	22	17	6	0	13	5	0	8	0	0
1868	16,807	4160	20,967	22	0	17	17	13	10	0	8	7	6	23	0	0	0	12	15	0	7	15	0
1869	16,856	4423	21,279	23	0	18	15	13	10	0	7	10	0	24	0	0	0	12	15	0	7	0	0
1870	13,624	570	14,194	24	0	18	15	13	10	0	7	10	0	25	0	0	0	12	10	0	7	0	0
1871	17,513	2800	20,313	24	10	19	5	14	0	0	8	0	0	26	10	0	0	13	10	0	7	15	0

TABLE IX.—NUMBER OF SHEEP OFFERED FOR SALE at the GREAT OCTOBER FAIR of BALINASLOE, with the NUMBERS SOLD, and their AVERAGE PRICES, in the last 22 Years—1850 to 1871 inclusive.

SHEEP.			AVERAGE PRICE OF WEDDERS.				AVERAGE PRICE OF EWES.				
Years.	Sold.	Unsold.	Total.	1st Class.	2nd Class.	3rd Class.	4th Class.	1st Class.	2nd Class.	3rd Class.	4th Class.
				£. s. d.	£. s. d.	£. s. d.	£. s. d.	£. s. d.	£. s. d.	£. s. d.	£. s. d.
1850	51,668	2,404	54,072	2 5 0	2 0 0	1 16 0	1 12 0	2 0 0	1 15 0	1 10 0	1 7 0
1851	47,072	3,477	50,549	2 7 0	2 2 0	1 18 0	1 13 0	2 10 0	2 4 0	1 17 0	1 11 0
1852	46,899	5,288	52,187	2 7 0	2 0 0	1 15 0	1 10 0	2 13 0	2 5 0	1 18 0	1 12 0
1853	46,096	16,260	62,356	2 15 0	2 5 0	2 0 0	1 13 0	3 0 0	2 5 0	1 17 0	1 10 0
1854	67,285	12,614	79,899	2 18 0	2 7 6	2 0 0	1 14 0	2 14 0	2 10 0	1 16 0	1 7 6
1855	79,311	4,871	84,182	3 0 0	2 9 0	1 14 0	1 14 0	2 14 0	2 8 0	1 14 0	1 5 0
1856	93,228	6,430	99,658	3 3 0	2 12 6	2 2 0	1 15 0	2 18 0	2 12 0	1 16 0	1 5 0
1857	79,368	1,350	80,718	3 8 0	2 17 6	2 6 0	1 18 6	3 2 6	2 16 0	2 2 6	1 10 0
1858	83,110	14,669	97,779	3 2 0	2 13 6	2 4 0	1 16 6	3 5 0	2 18 6	2 5 0	1 12 0
1859	73,761	20,889	94,650	3 0 0	2 9 6	1 19 0	1 10 6	3 1 0	2 16 0	2 2 0	1 7 0
1860	76,386	5,275	81,661	3 5 0	2 19 6	2 1 0	1 12 0	2 18 0	2 14 0	1 19 0	1 6 0
1861	70,831	4,287	75,118	3 3 0	2 11 0	2 1 0	1 10 0	2 16 6	2 10 6	1 17 6	1 6 0
1862	57,752	14,245	71,997	3 4 6	2 12 0	1 19 0	1 9 0	3 0 0	2 12 6	1 19 6	1 7 6
1863	53,954	19,540	73,494	3 3 0	2 10 0	1 17 0	1 7 6	2 17 6	2 10 0	1 17 0	1 6 0
1864	67,681	3,674	71,355	3 3 0	2 10 0	1 17 0	1 10 0	3 3 0	2 14 0	2 0 0	1 10 0
1865	64,607	1,923	66,530	4 0 0	3 5 0	2 10 0	2 5 0	5 0 0	4 5 0	3 10 0	2 5 0
1866	64,232	9,270	73,502	3 17 6	3 0 0	2 6 0	1 18 0	4 10 6	4 0 0	3 7 6	2 2 0
1867	66,146	7,218	73,364	3 10 0	2 10 0	1 14 0	1 6 0	3 15 6	3 5 0	2 12 6	1 10 0
1868	67,027	9,736	76,763	3 4 0	2 14 0	1 17 0	1 10 0	3 10 0	3 4 0	2 12 6	1 10 0
1869	74,544	1,925	76,469	3 10 0	2 18 0	2 1 0	1 14 0	3 15 0	3 9 0	2 17 0	1 12 6
1870	71,910	600	72,510	3 18 0	3 5 0	2 7 6	2 0 0	4 0 0	3 14 0	3 1 0	1 15 0
1871	72,224	12,343	84,567	4 4 0	3 10 0	2 12 6	2 2 6	4 10 0	4 0 0	3 8 0	2 2 0

The farms over 200 acres in extent are 9751 in number, and the acreage so held 4,904,582 ; being an average of nearly 503 acres in each farm.

Although the table shows that there are altogether 593,282 "holdings" in Ireland, yet as more than one "holding" is frequently occupied by the same person, the mere enumeration of separate holdings does not convey a correct idea of the actual number of occupiers, and these we find by reference to another of the Registrar-General's tables to consist of 537,433 persons.

TABLE X.—VARIATION in the NUMBER of HOLDINGS in each CLASS, between 1841, 1851, and 1869.

SIZE OF HOLDINGS.	Leinster.	Munster.	Ulster.	Connaught.	TOTAL.
	Number.	Number.	Number.	Number.	Number.
Above 1 to 5 acres .. { 1841	50,110	57,857	102,215	100,254	310,436
.. { 1851	25,711	14,200	29,709	18,463	88,083
.. { 1869	21,810	12,195	24,806	17,084	75,895
Increase or decrease in number between 1841 and 1869 .. }	Decrease. 28,300	Decrease. 45,662	Decrease. 77,409	Decrease. 83,170	Decrease. 234,541
Rate per cent .. .. .	56·5	78·9	75·7	83·0	75·6
Above 5 to 15 acres .. { 1841	46,039	61,753	99,605	45,402	252,799
.. { 1851	33,058	24,365	85,176	49,255	191,854
.. { 1869	27,603	20,254	74,486	49,356	171,699
Increase or decrease in number between 1841 and 1869 .. }	Decrease. 18,436	Decrease. 41,499	Decrease. 25,119	Decrease. 3,954	Decrease. 81,100
Rate per cent. .. .. .	40·0	67·2	25·2	8·7	32·1
Above 15 to 30 acres .. { 1841	20,688	27,611	25,219	5,824	79,342
.. { 1851	26,006	28,855	57,651	28,799	141,311
.. { 1869	23,224	25,405	56,530	31,927	137,086
Increase or decrease in number between 1841 and 1869 .. }	Increase. 2,536	Decrease. 2,206	Increase. 31,311	Increase. 26,103	Increase. 57,744
Rate per cent. .. .. .	12·3	8·0	124·2	448·2	72·8
Above 30 acres .. .. { 1841	17,943	16,665	9,655	4,362	48,625
.. .. { 1851	38,096	53,074	37,813	20,107	149,090
.. .. { 1869	39,660	56,173	41,035	22,340	159,208
Increase or decrease in number between 1841 and 1869 .. }	Increase. 21,717	Increase. 39,508	Increase. 31,380	Increase. 17,978	Increase. 110,583
Rate per cent. .. .. .	11·20	237·1	325·0	412·2	227·4
TOTAL .. .. { 1841	134,780	163,886	236,694	155,842	691,202
.. .. { 1851	122,871	120,494	210,349	116,624	570,338
.. .. { 1869	112,297	114,027	196,857	120,707	543,888
Increase or decrease in number between 1841 and 1869 .. }	Decrease. 22,483	Decrease. 49,859	Decrease. 39,837	Decrease. 35,135	Decrease. 147,314
Rate per cent. .. .. .	16·7	30·4	16·8	22·5	21·3

Small farms abound in all parts of Ireland, but they are more numerous in Ulster than in any of the other provinces. In Ulster, however, as well as in other parts of Ireland, the tendency is towards a diminution of the number of small holdings, and a consequent increase of a larger class of farms. This has been going on more especially since the "famine years," when many persons abandoned their holdings altogether. For the most part the consolidation of farms has been carried on very quietly. For instance, a man occupying a few acres of land, intimates that he wishes to give up his place in order to emigrate. A neighbour, with the consent of the landlord, and sometimes without it, gives the out-going tenant a sum of money for the "goodwill" of the place, and adds it to his own farm. Table X., p. 27, from the Registrar-General's Returns, shows the change which has been going on in the size of holdings in each province, the periods taken for comparison being 1841, 1851, and 1869.

In classifying the farms in Ireland for the purpose of describing the management pursued, either generally or in individual cases, the simple arrangement of (1) small, (2) medium, and (3) large farms may be followed.

#### SMALL FARMS.

"The agriculture, if such it can be called, of the small farms shows great slovenliness, and the appearance of the country generally is that of stagnation. Immense wastes are undrained; the buildings appear to have had nothing done to them for years; the ditches are unscoured; and the gaps in the fences appear to have been made years ago, and never repaired."

Such was the verdict pronounced by Mr. Peter Maclagan, M.P., after visiting nearly all parts of Ireland in 1869.\* Mr. Maclagan is well known as a practical agriculturist of high standing, and his remarks on subjects connected with farming are therefore to be received with due respect. The foregoing observations refer more especially to the tillage lands in the south and west of Ireland, for Mr. Maclagan further states that, "in Ulster the farming is better," and that province, as we have seen, is noted for the large proportion of small farms which exist in it.

But Mr. Maclagan is not the only modern authority who has pointed out the defective state of Irish agriculture with respect to cultivation. Mr. Thomas Baldwin, Superintendent of the Agricultural Department of National Education, states in a little work which he has recently published,† that "throughout the country

\* 'Land Culture and Land Tenure in Ireland,' by Peter Maclagan, M.P. Blackwood and Sons, 1869.

† 'Small Farms made Profitable.' 1871.

we meet a great many farmers who till their land in a very creditable way; but it is notorious that on the vast majority of small farms the mode of management is very bad;” and he then proceeds to point out what he considers “the most glaring defects” in the management, which may be summed up as follows:—Neglect of a rotation of crops: the infrequency or absence of turnips and mangold among the cultivated crops; the neglect of artificial grasses; slovenly cultivation; inattention to keeping the land free from weeds: neglect with respect to the collection and preservation of farmyard manure; neglect in the treatment of all farm crops, but more especially the hay crop; neglect with respect to the proper breeding of live stock; defective dairy management; want of proper drainage; waste of land by reason of the multitude of large unnecessary fences, &c. This is a serious catalogue of defects, but it is one which, unfortunately, cannot be denied. Hitherto, it has generally been considered a sufficient reply, when such defects have been pointed out, to say that the Irish farmer had no security, and that he would not be permitted to enjoy his improvements, in the event of his making them. Without discussing this point, it is sufficient to say that the avowed object of recent legislation has been to protect the enterprising Irish farmer, and thus stimulate him to expend capital on the improvement of his land. I believe that the Land Act of 1870 does give security where it was required, and it is to be hoped that the fruits expected to be derived from the measure will ultimately be realised. As yet there are comparatively few symptoms to be observed of the stimulating operation of the Land Act in promoting improvement; but sufficient time has not elapsed to give it that fair-play which moderate men of all classes are desirous it should receive.

Mr. Baldwin sets down neglect of a rotation of crops as the first “glaring defect” in the mode of management pursued on “the vast majority of small farms.” Oats and potatoes are the prevailing crops, and the former is frequently grown year after year, until the land becomes thoroughly run out. As a result of this system, it will in many instances be observed that the oat crop in one field appears to be tolerably good, while in the next it is so very thin and short as scarcely to be worth reaping, a close and luxuriant growth of weeds usurping the place which ought to be occupied by a more profitable description of plants. Turnips are rarely to be seen in many parts of the country, or, if seen, only in small patches, and, too often, smothered with weeds. Yet, strange to say, men who do not grow turnips themselves will often travel long distances during winter and spring to purchase a few hundredweights for their cattle; and, apparently, they

are quite content to pay high prices for the same, although they might easily have them on their own farms.

It will be observed that bare fallow occupies a small percentage of the land in cultivation as given in Table V. (p. 22). It seems strange to say at the present day, that the bare fallows which enter into the Registrar-General's annual returns are caused chiefly by the want of manure on the farms where this system is practised. Few turnips, or rather none, are grown on such farms, although their consumption by cattle would produce dung; the straw as well as the grain is sold; no town manure can be obtained; and there is literally nothing whatever to assist the soil, exhausted by previous over-cropping, except the ameliorating influences of the atmosphere upon the bare surface during the fallow year. Fallow, wheat, and oats for a series of years, appears to be the course of cropping in such cases; and when manure is applied to the fallow—which is not always the rule—it usually consists of some earth from the headlands, mixed with a little lime. Even the summer working of the fallows, upon which the effects of that operation so much depend, is not usually carried on as it should be done. It is frequently the end of June before a plough is put into the land to give it a second furrow, and sometimes it looks at that time of the year as if it had not been ploughed before or during winter. It is a poor system altogether; and the fact that tolerable crops are produced after it speaks more for the natural fertility of the soil than the judiciousness of the mode of cultivation which is followed.

In certain wheat-growing districts in County Kilkenny, a practice of growing wheat for several years in succession has prevailed for a long time, the land being limed at least every alternate year, and in many instances every year. Sometimes a crop of potatoes intervenes, but this is not the rule in all cases. Fields which have undergone a long course of this treatment do not turn out satisfactorily when laid down to grass, having usually as pasture a burnt-up and barren appearance. At the same time, the luxuriant growth of natural grasses which may be observed in corners, or other spots which have not been cultivated, shows plainly that the land would have produced good pasture if it had been properly treated. The soil in the district referred to is naturally a limestone soil.

Neglect of weeding has also been mentioned as one of "the most glaring defects" in ordinary cultivation, as pursued in Ireland. This fact strikes every stranger who looks at matters with the eye of a trained agriculturist. The late Mr. Edward Carroll, an Irish writer on agricultural subjects of long experience, published a statement a few years ago, to the effect that he had had the curiosity to weigh both the weeds and potatoes produced

at the digging season on a certain piece of ground, and the result was that while the produce in potatoes amounted to four tons, that of weeds was eleven tons! and Mr. Carroll's statement is corroborated by Mr. Baldwin, who says that "it is no uncommon thing to find ten tons of weeds in an acre of potato ground."

Weeding is a department of farm work which many Irish landholders appear to consider unnecessary; and others, from whose position better things might be expected, not unfrequently object to the operation on the ground that it is an expensive proceeding, forgetting altogether that every year in which weeding is neglected serves to increase the evil tenfold. Nor is the neglect of weeding confined to cultivated land. Thistles, docks, and ragworts—the latter especially in cattle pastures where no sheep are kept—flourish unmolested in the grazings; and where land is laid down to grass the seeds sown are little better, in too many instances, than a collection of the seeds of weeds, being derived chiefly from the sweepings of hay-lofts, dressed up to suit those who consider such "seeds" more economical than any mixture which would be supplied from a respectable seed warehouse.

As an illustration of this mode of "laying down land," I shall give some details of one instance which came under my observation, not in any remote district, but within an hour's run of Dublin by rail. I must premise, however, that it was not on a small farm where the "system" I mean to describe occurred, but on a farm which would be classed among the medium holdings.

In the case to which I refer, it had been thought necessary to break up some of the old grass fields on the farm, for the purpose of renovating them; and the course pursued was to take four or five successive crops of oats, and to sow the "grass seeds," which were of the worthless description mentioned above, with the fourth or fifth crop, without any further preparation. One field, however, after carrying a succession of crops of oats, had been fallowed, preparatory to sowing the grass seeds. The fallowing consisted in ploughing the stubble of the previous crop during winter, and nothing further was done until the field was covered with a fine growth of couch-grass and thistles, and then a scratch cross-ploughing was given to the land. The harrows were set to work to level the surface, after which the "grass-seeds" were sown about the beginning of August, and the whole finished by rolling. The headlands were left untouched, not having been ploughed, even in winter: no manure of any kind was put on the land; not a single weed was picked off; the roots of the couch-grass lay in wisps all over the field, just where they had been shaken off the harrows; and the result was a noble crop of couch and thistles, and a poor prospect for pasture; although in the course of time the land would become stocked with natural grasses, which spring

up spontaneously in Ireland wherever the soil is of a kindly nature.

Returning to the question of farm management on small holdings, it will be evident that the system which prevails in most parts of Ireland is not calculated to increase materially the production of live stock. It is an old saying that without green crops there can be no cattle ; and without cattle, no manure ; and without manure, no corn. The whole rests on green, or root crops ; and this foundation is wanting, generally speaking, in the routine of farm management in Ireland, whether on small or large occupations. There are, of course, numerous exceptions to the rule : but these are not sufficiently prevalent to affect the general principle.

It will be seen, however, by referring to Table VII., p. 24, that live stock to the value of over seventeen and a half millions sterling is owned by occupiers of farms not exceeding fifty acres. When the total amount is apportioned among the holders, according to their average acreage, it will be found that it represents a much larger value of stock per acre than belongs to all classes of occupiers holding over 50 acres. Of course, in the case of the occupiers under 50 acres, there is a certain proportion of the value of the stock credited to them which does not belong to those who are, strictly speaking, landholders ; seeing that stock owners who do not hold land, such as dwellers in cities and towns, are included in the class of occupiers whose holdings do not exceed one acre in extent.

Setting this aside, however, it becomes necessary to inquire into the details of stock-rearing by the class of small farmers, and to see whether any material increase in the number and value of the live stock held by that class of occupiers is practicable. It is evident that they are already producers of stock, in some shape or other, to a large extent.

Upon analyzing the official returns, it will be seen that there are a million and a half milch cows in Ireland, and that of these over 900,000 belong to occupiers whose holdings do not exceed 50 acres in extent. From the same source, we learn that about 421,000 calves are reared, being a little more than one calf for each two cows. The proportion of calves to cows varies in different counties, and is least in those districts where dairy farming is most prevalent. Some of the calves are fattened and sold as veal calves ; but in the majority of instances, especially among the small farmers, the milk required for vealing a calf, or even rearing it, is grudged, as so much subtracted from the material available for butter-making : and for that reason many calves are



sold when a few days, or even a few hours old, going in that state under the name of "slink veal," or "staggering bob." Those calves which are reared, are fed at the least possible expense—sour-milk, hay-tea, and other articles being generally substituted for the food which nature intended that they should receive. A mixture of linseed meal and bean meal, equal parts of each, made into gruel, is occasionally used by some persons who pay more than ordinary attention to rearing calves, the allowance being about three-fourths of a pound of the mixture to each calf per day; and it is found to suit the purpose very well, when the linseed meal is made from the pure seed. When it consists merely of cake ground fine, it is of much less value for feeding purposes.

Of the 421,000 calves reared by farmers holding under 50 acres, 120,000 are sold by them in autumn as weanling calves, or early next spring, previous to the period—June—at which the agricultural census for the year is taken. Those young animals are bought by graziers in certain districts, who do not rear enough to suit their requirements, and a considerable proportion of them are exported to England and Scotland. When wintered at home, the calves are for the most part poorly kept. On farms which are wholly or chiefly in grass, the calves, as well as cattle of other ages, are run in the open fields, generally without any shelter, night or day, beyond that which is afforded by a fence or bush, and only getting hay in case of a storm. Even on tillage farms the young stock frequently do not receive the care which ought to be bestowed upon them. The stinting and starving system of rearing leaves its effects behind it, because the animal which has undergone it is never so valuable when older as one that has been well and regularly fed from the first. So far, therefore, from the stinting system being an economical mode of rearing cattle, it is quite the reverse, being both wasteful and expensive; and the evil is rendered worse when the animals are inferior in point of breeding. Upon a badly bred, half-starved animal, good keep is thrown away.

The principal remedy is, evidently, a more extensive cultivation of root and forage crops by farmers who already contribute so much to the cattle supplies of the country. This would enable them to keep the stock already reared by them in better condition than at present; and, if fully carried into operation, it would also enable them to rear a larger number of animals, as a result of the increased supplies of food thereby obtained.

Great difficulty has invariably been experienced by those who have attempted to introduce an improved system of cultivation among the ordinary small holders. Small holdings form a predominating feature in Irish agriculture; and although there

has been a natural process of consolidation going on for several years, and is going on quietly at the present time, yet we must take into account that Ireland will show a preponderating number of comparatively small farms for many years to come. These farms, as we have seen, already form an important nursery of young stock, and if their capability in this respect could be increased, a great step would be gained. This can only be effected by better farm management; that is, by the industry of the people being directed and employed in a more advantageous manner for themselves and the community than has hitherto been done in most cases.

About forty years ago, the late Mr. William Blacker held the agency, or stewardship, of the estates belonging to the Earl of Gosford and Colonel Close. These estates are situated in the county of Armagh, which contained, and still contains, the largest proportion of small holdings of any county in Ireland. In order to afford the tenantry under his charge the opportunity of having their industry directed by greater knowledge than they themselves possessed, Mr. Blacker devised a system of practical instruction which was attended with the most satisfactory results. This consisted in employing experienced agriculturists to go from farm to farm, and to point out to the occupiers such improvements as might appear practicable, and as the particular circumstances of each farm required. The agriculturist showed where draining was required, and superintended its performance; showed how the land was to be cleared of weeds, the very meaning of which the people did not at first understand; pointed out how manure might be acquired; how to grow root and forage crops: and showed how house-feeding the cattle, a most important matter on such farms, might be established. The agriculturist lived among the tenantry, went about among them from day to day; talked to them familiarly as they worked in their fields, and discussed the operations they were engaged upon; and gave in this way, to any tenant, practical information on any subject at the time it was required.

The results of this system soon became manifest, and in the space of three or four years after it had been fairly at work, Mr. Blacker reported that the great difficulty experienced by the tenants was, to procure cattle to consume the increased quantity of food which they found themselves possessed of; not, as previously, to get food for the small number of animals then kept by them. In fact, it appears from the returns which were given by Mr. Blacker, that the increase of stock, chiefly cows, amounted to two hundred per cent., and in some instances it was even as high as four hundred per cent.

When the details and results of Mr. Blacker's system were laid

before the public in 1834, in the form of a Prize Essay on the 'Management of Landed Property in Ireland,' its value was at once recognised, and many proprietors at the time, and in subsequent years, proceeded to adopt it. In 1847, the Royal Agricultural Society of Ireland, at the suggestion of Lord Clarendon, who was at that time Lord-Lieutenant, selected certain districts in the south and west of Ireland, where the effects of the potato rot had been severely felt; and to these districts practical agriculturists were sent to stimulate and encourage the working farmers, and teach them how to cultivate their lands. The efforts of those men were seconded by liberal grants of seeds, supplied by the Society of Friends and other sources; and evidences of the good effected by the instructors are to be seen at the present day in the districts to which they were sent. The same system of practical instruction has been carried on for the last seven or eight years by a Committee appointed to administer a small annual grant which has been given by the Government for the purpose of instructing small farmers in the south and west of Ireland as to the proper cultivation of flax. It also exists on different estates, but the instances in which it is in operation are now comparatively few in number. It is a system which requires the hearty co-operation of the agent, as well as of the landlord, with the agriculturist, and where that co-operation has been wanting, it has gradually died out. This is much to be regretted, as there is sufficient proof to show that it is a system well calculated to promote the prosperity of the country.

Among those proprietors who have steadfastly adhered to the system of estate agriculturists, for the purpose of practical instruction, the Earl of Erne is perhaps the most distinguished. His lordship has had the system in operation on his estates, for a period of nearly thirty-five years, and during all that time his estate in County Donegal has been under the charge of the same individual. The result is that the entire estate is closely cultivated on a rotation of which turnips, and artificial grasses form the leading features. The turnip crops are as clean and well cultivated as in any part of the United Kingdom; and a regular system of progressive improvement has been carried on, at the joint expense of landlord and tenant, under the supervision of the agriculturist. These improvements include draining, subsoiling, making new fences, levelling old or useless fences, making farm roads, clearing off large stones which are found in the land, putting up iron gates, making embankments, levelling and filling up old quarries, &c. There is also a special allowance for buildings, and the consequence is that the farmhouses and offices are generally very good. The average size of farms on the estate is

now about 50 statute acres, but on Lord Erne's estates in County Fermanagh, where the same system has been carried on, the farms are less in extent; nevertheless, the occupiers are thoroughly comfortable. On this point I take leave to quote from a report on Lord Erne's estates made by me some years ago, after a very minute examination of the farms. "There is no one who can see the tenantry on the Erne estates without being struck with the remarkably respectable appearance they present, whether at home or abroad; and those who imagine that a class of small farmers must necessarily be a struggling impoverished race, ought to visit the Erne estates before they decide in this matter."\*

In the report to which reference is made, an account is given of a farm consisting of  $9\frac{1}{4}$  statute acres, which had been reclaimed entirely out of bog. It was under a four-shift course, and maintained four head of cattle, an ass, and two or three pigs. Three of the cattle "were as good cows as any man would wish to see about his farm." On another farm of scarcely 20 acres (statute) four excellent cows, two or three calves, and half-a-dozen of pigs were kept, and kept well; and on another farm of 15 acres five cows and a calf were house-fed. The crops grown for the use of those animals were of course in addition to corn, potatoes, and sometimes flax crops; and the instances quoted are not taken as exceptional, but as a fair illustration of the results of the system of practical instruction which has been carried out on Lord Erne's estates. That system is still in operation, no change having been made in the details, except to introduce improvements where experience has shown that such were practicable.

A similar system has, as I have already intimated, been carried out on other estates, and notably so on those belonging to the Earl of Longford in the counties of Westmeath and Longford, and the Earl of Arran in Mayo, the late Lord Palmerston's estates in Sligo, the Duke of Devonshire's estates, the Marquis of Londonderry's estates, and others.

About thirty years ago nearly the whole of Lord Longford's estates in Westmeath were held under very old leases, and, as was customary in such cases, the land so held was subdivided into an immense number of very small holdings. Scarcely any one person held his land in one compact lot or farm; one field or patch of ground might lie in the immediate vicinity of the occupier's dwelling, but a second patch was perhaps half a mile away in one direction, and a third as far, or farther, in another. This system prevailed at one time in most parts of Ireland, and instances of it are still to be met with. Where it does exist, the people are very averse to having their land "striped," or laid off

\* 'Irish Farmer's Gazette,' vol. xvi. p. 923.

in compact lots, but once it is done, they soon find the advantage of having their land all lying together.

As the old leases on Lord Longford's estates terminated, the lands were taken in hand and reduced to proper order. An agriculturist of great practical experience, who is still in his lordship's employment, was engaged: every farm was squared, and laid off in six equal sized fields or lots, one of which was occupied by the houses, yards, &c., the remaining five being devoted to the purposes of cultivation, the intention being to introduce a five-course rotation—the ordinary four-course shift lengthened by pasture for a year—as being best adapted to the circumstances of the estate. The new fences, hedges, dykes, and ditches, were made at the proprietor's expense; roads were constructed where such were required to open up the estate; arterial drainage to relieve the low-lying land subject to floods was effected, partly in co-operation with adjoining proprietors; each farm was thoroughly drained in an efficient manner under the superintendence of the agriculturist at the joint expense of landlord and tenant, and systematic cultivation was introduced. To encourage the tenants, the proprietors supplied them with grass seeds and turnip seeds at prime cost, but this has long since become unnecessary, as a system of cultivation embracing the growth of artificial grasses and roots soon became familiar to them. From the circumstance that, previous to the "famine years," a beginning had been made in systematic farming by the tenantry on Lord Longford's estates, the pressure of that period was not felt so heavily by them as it was in those districts where the condition of the small landholders had been previously neglected. The average size farms on his lordship's estates are from 30 to 50 statute acres, very few reaching 100 acres.

As the estate contains a considerable extent of deep bog, a wing, in fact, of the great Bog of Allen, it may be useful to note some points connected with the reclamation of that description of land as carried out on it.

Draining was of course the first step, and all the bogs on the estate were drained by means of deep cuts run in straight lines, no matter what obstruction intervened, and even after the bogs had subsided many of these cuts were, and still are, fully ten feet deep. To sink large open drains of this kind in shaking bog, was a task of considerable difficulty. The plan adopted by the agriculturist, in order to prevent the cuts from filling in nearly as fast as they were opened, was to mark off the line of drain, and then open pits, along this line, 18 feet in length by 12 feet deep, the width at the surface corresponding to the depth, and gradually sloping on each side to about three feet in width at the bottom. Unbroken spaces of three and four feet were left between each pit, and as the latter were completed, the intervening spaces were

tunnelled through, which provided a passage for the water, while the bridge, or unbroken space above, acted as a wedge, and prevented the drain from being filled up in consequence of the lateral pressure arising from the gradual subsidence of the bog. These drains were afterwards deepened, if required, and kept clear. Once they were fully in operation, the drainage and reclamation of the adjacent land became comparatively easy.

As an illustration of what has been done on this estate in the reclamation of deep bog, I may refer to the proceedings adopted by the late Mr. Moore, of Killucan, who was one of Lord Longford's tenants. About 50 statute acres of red bog, fully 18 feet in depth, having been taken in hand, the first thing done was to put up a house in the centre, for the purpose of serving, in the first instance, as a shelter for the labourers employed, and afterwards as part of a farmstead. Before this could be done a large quantity of brushwood had to be carried to the intended site of the house on men's backs, the ground being too soft to admit of any other mode of transport. The brushwood was intended to serve as a foundation and a floor for the building. All the other materials, wood and clay, were carried to the place in the same manner, no four-footed animal capable of carrying a burden being able to walk safely over the shaking bog. The next step taken was to lay off the land into squares, containing about three acres in each, with an open drain five feet deep between each lot. The covered drains were then cut four feet deep on the wedge-drain system. The first crop taken was potatoes, which were planted with the spade in ridges, or beds, four feet wide, with open spaces two feet wide between each ridge. On part of the land two successive crops of potatoes were grown before sowing a grain crop with grass seeds, whilst another portion of the bog was brought in without breaking the surface. In this case the land was laid out in beds, and the soil from the intervening spaces was spread over the unbroken surface. Oats and grass seeds were then sown, and covered with a compost made of old earthen fences and stable-dung. The crop of oats was very fair, and the sward of grass was better than that on the land where the surface was broken. The crops of potatoes grown on this bog were most abundant, and being quite untainted with disease, realised very remunerative prices as seed. The entire appearance of the land when reclaimed and laid down in grass presented a remarkable contrast to the expanse of brown heath by which it was surrounded. It now grazes a number of Kerries during summer.

In the case of the Earl of Arran's estates there was the same subdivision and confused mixture of patches to contend with; and, until they were remedied, they completely frustrated every

attempt to introduce the cultivation of roots and artificial grasses. By persevering, however, in the course he had laid down, assisted by two practical estate agriculturists, his lordship succeeded in effecting a great reformation in the condition of the tenantry on his property, not alone with reference to the cultivation of their holdings, which are generally of a small size, but also in their dwellings, and in the establishment of various branches of household industry, such as the home manufacture of linen, linsey-woolsey, and frieze, a most comfortable and durable article of wear when made up into overcoats. A number of specimens of these home-manufactured articles were exhibited at the Royal Dublin Society's Exhibition in 1865, and still remain in the museum of that institution "as an evidence of what can be done by the Irish peasantry when properly fostered and encouraged." I may state that, while in the other illustrations of estate improvement which have been mentioned, I base my remarks on personal knowledge of the circumstances; in that of Lord Arran's estate, I do so on the authority of a gentleman who has been conversant with the proceedings from their first commencement down to the present time.

The agricultural schools which have been established in different parts of Ireland under the National Board of Education, were designed to diffuse practical information on improved systems of farm management among the ordinary class of Irish farmers. This system of instruction is, however, too important to be passed over in a cursory manner, and I hope, therefore, to devote a paper specially to a description of the various details connected with it.\*

As a rule the small farmers in Ulster are more comfortable than the same class in most parts of the other three provinces. Their houses have generally a tidier appearance, and their internal arrangements, with reference to furniture, &c., are much superior to those which are to be found elsewhere. Since the great advance which has taken place in the prices of farm-produce, especially dairy produce,† there has been no scarcity

\* The description of the system of agricultural instruction pursued by the Board, together with some "Illustrations of Farm Management" in Ireland, will appear in subsequent articles.—EDR.

† The following comparative list of prices, taken from the 'Dublin Market Notes,' will show the advance which has taken place in certain articles of farm-produce:—

		July 12, 1851.	July 14, 1871.
Beef, per cwt. .. .. .	.. .. .	44s. to 48s. ..	60s. to 75s.
Mutton, per lb. .. .. .	.. .. .	4 $\frac{3}{4}$ d. ,, 5 $\frac{3}{4}$ d. ..	7 $\frac{1}{2}$ d. ,, 9d.
Lambs, each .. .. .	.. .. .	18s. ,, 22s. ..	25s. ,, 40s.
Butter, per lb. .. .. .	.. .. .	5d. ,, 7 $\frac{1}{2}$ d. ..	10d. ,, 13d.
" per cwt. .. .. .	.. .. .	56s. ,, 68s. ..	93s. 4d. ,, 112s.
Pork .. .. .	.. .. .	32s. ,, 35s. ..	48s. ,, 50s.
Eggs, per 124 .. .. .	.. .. .	4s. 6d. ,, 4s. 8d. ..	6s. 8d. ,, 7s.

of money among the farming classes, including those of the humblest rank, in all parts of Ireland; and this state of matters has been materially assisted by the circumstance that, on many estates which remain in the hands of the original proprietors, the rents continue to be much as they were 20 years ago. Irish small farmers, for the most part, prefer to hoard their savings, and it is only when a son or a daughter gets married, and when their respective portions are forthcoming, that one is enabled to form some idea of the amount which has been quietly accumulated, as the result of great thrift, assisted by a low style of living, and very moderate ideas of what is usually considered comfort. Statisticians frequently refer to the increased amount of deposits in banks, by Irish farmers, as an evidence of the prosperity of the country, but these, I believe, fall short of the reality. Money is hoarded in out-of-the-way places, instead of being deposited in banks, of the solvency of which many appear to entertain considerable doubts. Money concealed in the thatch of a house, or in a straw mattress, does not fructify, as it would do if properly invested; but with many this fact does not appear to have any influence. The idea of expending money on their farms, or, as it is said, "improving another man's land," would appear to them perfectly absurd. Whether recent legislation will counteract this feeling remains to be seen.

The comparatively superior condition of the small farmers in Ulster has arisen, I believe, in a great measure, from the perfect sense of security they have long enjoyed in consequence of the Ulster custom of tenant-right, which, however, was not legalised until the recent Irish Land Act was passed. Still, it was recognised by proprietors and tenants, and acted upon whenever circumstances arose which led to a change of occupancy. On some estates the limit of tenant-right was fixed, so that it could not exceed a certain sum per acre; in other cases its value fluctuated according as the times were good or bad. Whatever were the arrangements regarding it which prevailed on an estate, so long as it was recognised, it imparted confidence to the occupying tenant; and, on the other hand, if a proprietor abolished it, as he had it in his power to do—the right not having been strictly legal—the condition of that estate underwent a rapid deterioration.

The cultivation of flax has also been of much service to the small farmers of Ulster. This crop, being early harvested, and speedily brought into marketable condition by aid of the scutching-mills, of which there are 1409 scattered throughout the province, puts the growers in funds to meet their November rents without much trouble. It is now, however, the opinion of all who have carefully considered the matter, that flax-growing



has been pushed rather too far in Ulster ; that is to say, it has been repeated too often on the same land. This opinion is supported by the estimates of the produce of flax per acre in each of the provinces, as published by the Irish Registrar-General. Thus, in 1869, the relative production of flax, per acre, was as follows :—

Ulster .. .. .	24·58 stones
Connaught .. .. .	25·18 „
Leinster .. .. .	30·49 „
Munster .. .. .	34·45 „

The estimates of previous years also placed Ulster lowest in the scale as to production. In the other provinces, the cultivation of flax is of recent date, having been stimulated by the small annual grant from Government, to which reference has been previously made, varying from 2000*l.* to 4000*l.* per annum. The grant was first made in 1864, when it consisted of a sum of 2000*l.* It was subsequently raised to 3000*l.*, and then to 4000*l.* ; but it has latterly been reduced to 2000*l.* It has been of great benefit to the districts where the instructing agriculturists were placed, and it is therefore hoped that the Government will continue to encourage this very practical form of “technical education.” As an illustration of the results, I give the following particulars, showing the increase which has been made in the number of scutching-mills in the three provinces, exclusive of Ulster, since the grant was first made :—

SCUTCHING-MILLS.

	1861.	1870.	Increase.
Leinster .. .. .	13	39	26
Munster .. .. .	7	39	32
Connaught .. .. .	4	31	27

Other proofs could easily be brought forward to show the stimulus which this small grant has given to agricultural and manufacturing industry in these provinces.

One important defect in the management of the Irish flax crop is, neglecting to “ripple” or take off the seed before steeping the flax. Considering the great importance of pure linseed for feeding purposes, the loss sustained in this way amounts in value to a large sum ; and it has been estimated that little short of half a million sterling is annually wasted in consequence of steeping the flax grown in Ireland without first undergoing the process of rippling. The expense of rippling is the usual objection ; but Mr. William Charley, who is a manufacturer as well as a farmer, and whose work on flax is a standard authority, shows that although a somewhat expensive operation, still it returns a profit of at least *cent. per cent.* It is

not easy, however, to induce people to leave the beaten track to which they have been accustomed; and thus year after year a large quantity of a most valuable article for cattle feeding is lost to the country, leaving us to use as a substitute cake, which is too often of inferior quality, if not worse.

I have been induced to enter at some length into the condition of the small farmers in Ireland, because the system of small farms is really a prominent feature in Irish agriculture, and is long likely to continue so. There is one point which should be understood and borne in mind in all speculations on the relative production of large and small farming in Ireland, namely, that wherever you find a number of small farmers located, it may be taken for granted that the land is of an inferior character. Tillage farming in Ireland is, in fact, for the most part found to prevail on the inferior soils of the country, and especially in the case of small holdings. There are no doubt parts of the country where such holdings consist of good land, but this is not the rule. The best soils are occupied as large grazing farms, and in such cases cultivation may be regarded as unknown. The small farmers have had much to contend with, arising from their ignorance of what are justly regarded as proper systems of cultivation and general management; but not the least obstacle they have had to encounter, in very many instances, has been the inferior quality of the soils upon which they have been placed. To this circumstance may be attributed certain peculiarities in their mode of cultivation, amongst which the most prominent to the eye of a stranger is the system of growing potatoes, and other crops, in narrow beds, having deep alleys between them. This mode of cultivation, usually known as the "lazy-bed" system, has been frequently condemned by writers from other parts of the kingdom, to whom it was new; but, nevertheless, something may be said in its justification. I do not like it myself, because it does not allow the land to be kept so clean as may be done under a proper system of drill, or "ridge," cultivation. It is the only way, however, by which, in many instances, a sufficient depth of earth can be obtained to grow a crop. The earth taken from the alleys is spread over the beds, and thus the breadth of the alleys is regulated by the nature of the soil. If the soil is shallow, the alleys are wide, so as to get sufficient earth to cover the seed, and to "mould" the plants, as it is termed; when the soil is moderately deep, the alleys are narrow and deep. Again, in the case of undrained land, which is too much the rule, the alleys serve as open drains; and, therefore, although the "lazy-bed" system is comparatively a rude style of cultivation, yet in many instances it is the only system which the people can

follow with any hope of having a crop. In some parts of Ireland, and especially in Ulster, it is usual when "moulding" the potato beds to lay in cabbage plants along the "brows" or edges of the beds, so that the heads of the cabbages overhang the alleys; and it is often surprising to see the quantity of food which is produced in this way, useful either for the people themselves or their live stock. Turnips and mangolds may frequently be found growing on beds similar to potato lazy-beds, and when the seed has been sown across the beds, with sufficient space between each row, and the plants afterwards properly thinned and weeded, very good crops of roots are grown in this way on thin soils. These points have to be taken into consideration before the "lazy-bed" system is absolutely condemned. In reclaiming pieces of rough land, I have occasionally resorted to it, and found that when applied to the cultivation of potatoes on such land, it greatly facilitated after operations.

One of the greatest drawbacks which the smaller class of land occupiers labour under is the lack of suitable power for the cultivation of their holdings. In most cases each man keeps a horse, and joins with a neighbour who is similarly circumstanced when he requires to plough his land, or do anything where two horses are necessary. Now the horses kept by such farmers are mostly weak weedy animals, quite unfit to allow the land to be cultivated to a proper depth. In fact, this statement holds good of many farms which cannot be called small farms; but, with special reference to the latter, I have long held the opinion, from what I have seen in such cases, that there is nothing equal to a bullock for the small farmer. Carting and everything has been done by a bullock on small farms where I have known such to be employed; and there is this advantage in an ox, that when not required, he may be readily sold or fattened; whereas a poor, weak horse is not always saleable, and when old is worth little more than the value of his hide and bones. Donkeys are kept by small farmers in many parts of Ireland, and are remarkably well kept in most instances, so that they get through a great deal of work, particularly in drawing the produce of the farm from the field to the homestead, or to market. Very small holdings are generally cultivated by the manual labour of the occupiers and their families. Spade cultivation is usually looked upon as the most efficient of all modes of culture, but such cannot be said of most of the small holdings in Ireland where it is in operation. One of the first things the practical instructors had to do after the famine years, was to take a spade and show the people how to dig the ground, and even yet we still see them inserting the spade in a slanting direction; so that the actual depth of soil turned over does not exceed 4 or 5 inches,

instead of double that depth. Their spades are heavy, and not well calculated for working with ; and it would be much to their advantage if they could be persuaded to substitute such implements as Parkes's steel digging forks for their present tools. Mr. Niven's "Garden Farm," at Drumcondra, near Dublin, which consists of 30 acres, is entirely cultivated by lads from 14 to 20 years of age, who use no other implements than steel forks, and with these they not only do the ordinary digging work required during the cultivation of the crops, but also trench a portion of the ground every year two feet in depth.

Of late years, machinery has begun to be used to a considerable extent by the small farmers, as well as by others, at least in districts where agriculture has made some advance. Reaping, mowing, and threshing machines are let out on hire by persons possessed of capital sufficient to purchase such machines ; and where these have been introduced, there is always plenty of employment for them during the seasons in which they are required. In more backward districts the use of machinery is confined to large farms.

#### MEDIUM AND LARGE FARMS.

There are so many features common to medium and large farms that we may class them together. They represent nearly all varieties of farm management, from a low style which would be improved were the owners to take examples from many who rank much lower in the social scale, to other instances which differ in no respect from the best illustrations of farming to be found in England or Scotland. Under this head may be found both medium and large farms, which are closely cultivated under a regular course of rotation cropping, and others which are in a condition little, if at all, removed from a state of nature, although consisting of good arable land.

On referring to Table IV., given on page 21, it will be seen that as the size of farms increases, over 50 acres, the proportion under crops diminishes, while that of grazing land increases. Thus, while out of the five and a half million of acres under crops nearly four million of acres are held by those whose occupations do not exceed 50 acres in extent, out of the 10 millions of acres in grazing lands upwards of six and a quarter million of acres are in possession of those whose holdings exceed 50 acres ; and, notably so, between 50 and 500 acres.

In several instances a number of medium-sized holdings are merged into the possession of one person ; and hence we find one family occupying, it is said, 60,000 acres as tenants, and another family in the occupation of 20,000 acres, all fine land, and all in

grass. There are many similar instances in different parts of the country, of large accumulations of land in the hands of one or two individuals.

We have seen that the farmers whose holdings do not exceed 50 acres in extent are possessed of stock valued at over  $17\frac{1}{2}$  millions sterling. In the case of the larger class of landholders the value of their live stock is very little over 18 millions sterling, although the extent in their possession is more than  $8\frac{3}{4}$  millions of acres, irrespective of bog and waste, against a little over 7 millions acres held by the smaller class of occupants. Hence, it is evident that the occupation of large holdings, when such are kept chiefly or wholly as grazing land, is not a system calculated to develop the food-producing resources of the country; inasmuch as it produces or maintains a smaller proportion of stock than we find maintained where cultivation, even although such is in many respects defective, is the predominating feature. This is a conclusion which many, I am convinced, were not prepared for, but it is the only conclusion at which we can arrive after duly considering the very carefully prepared returns submitted to the public by the Irish Registrar-General; and, I may add, it is a conclusion which is borne out by facts.

The grazing system, as pursued in Ireland with reference to the rearing of live stock, may be described as a system which is based altogether on unassisted nature. Art has nothing whatever to do with it, beyond saving a crop of hay on some piece of old pasture which has been specially reserved for "meadowing." There are no houses on such farms for sheltering cattle during winter, and the only cultivation which is to be seen in many grazing districts is to be found in a paddock adjoining a herd's house, and that is confined to an acre or two of potatoes and oats for the use of the herd's family. Not a turnip is to be seen. Here and there patches of rape are grown, chiefly, however, where sheep are kept. Where this state of matters exists, the grazings are not rough mountain pastures, but fine undulating tracts of country, capable of easy cultivation, and when cultivated, or where land of a similar kind is cultivated, producing magnificent crops of turnips. The manner in which cattle are kept during winter has been already hinted at. They run at large over the pastures, and it is only during severe weather that they get any artificial food, which is simply hay, scattered over the ground. In those parts of the country where hedges are abundant and well-grown, or where plantations exist, the outlying cattle have shelter to some extent, but there are many stock-rearing districts which do not possess those advantages. The early part of the summer grazing is, therefore, spent in recovering the condition lost during winter; and thus the cattle pass through alternating

periods of fulness and scarcity, until they are transferred to a higher class of pastures, where they are fattened, or to the feeding stalls of English and Scotch farmers.

It has been alleged that this is a cheap mode of rearing cattle. As to the actual expense, the following estimate will show how much it costs to bring a three-year-old bullock to Ballinasloe fair on the 1st of October; and I may state that the estimate has been submitted to several persons interested in the question, who agree as to its correctness:—

	£.	s.	d.
Value of calf on 1st November .. .. .	5	0	0
Keep till next May .. .. .	1	0	0
Summer keep till 1st of November .. .. .	1	10	0
Second winter's keep .. .. .	1	10	0
Second summer's keep .. .. .	2	10	0
Third winter's keep .. .. .	2	0	0
Keep from 1st of May to 1st of October .. .. .	3	0	0
	<hr/>		
	£16	10	0

This is altogether irrespective of interest on capital, expense of marketing, &c. A comparison of the cost of rearing a three-year-old store bullock, with the average prices of such cattle at Ballinasloe fair, given in Table VIII., p. 25, will show that the ordinary mode of rearing cattle in the grazing districts of Ireland through the medium of unassisted nature is by no means a cheap or very profitable system.

Another test of the “cheapness” or profitableness of a system of management based upon unassisted nature may be obtained from the following calculation: By the last Agricultural Returns we learn that there are in Ireland 842,183 calves or yearlings; 745,863 two-year-old cattle; and 2,385,056 three-year-olds and upwards. Assume that one-third of the number in each class are not allowed to retrograde in condition, and that each head of the remaining two-thirds lose flesh during the winter and spring months in the following proportions: yearlings, 2 stones of 14 lbs.; two-year-olds, 4 stones; three-year-olds and upwards, 6 stones: then we find a total loss of flesh amounting to 12,652,076 stones, or 1,581,509½ cwts., which, at 60s. per cwt., represents a money value of 4,744,528*l.*; say nearly five millions sterling lost annually owing to the flesh being literally wasted off the bones of the animals. This loss of flesh is equivalent to an allowance of nearly 2½ stones of meat to each man, woman, and child in Ireland.

But there are other considerations which affect the question of production. It is admitted that a breed of cattle has been widely disseminated throughout Ireland, one prominent characteristic of which is aptitude to fatten, or, as it is usually designated, early maturity. But this characteristic, although inherent in the breed,

cannot be fully developed unless under favourable circumstances. Starvation, or semi-starvation, will not bring it out, although the possession of it assists materially, I have no doubt, in enabling the animal when put on good pasture to speedily overcome the effects of the treatment to which it had been previously subjected. Hence the rapid improvement which Irish cattle of a good description exhibit when put on good grass in summer, as they pick up flesh wonderfully fast, that is, externally; for it is believed that they do not "tallow" as well as cattle which have been regularly kept in an improving state from the first.

With reference to this point, I take leave to quote from a letter I have received from an Edinburgh butcher, who has had for many years a large trade in that city, and whose opinion, as a practical man, is entitled to be received with respect:—

"My experience (as an Edinburgh butcher) of Irish grass-fed cattle, is, that they, to use a butcher's phrase, are in general 'bad diers;' that means a deficiency of inside tallow compared with the ordinary run of Scotch-fed beasts; and when tallow is wanting, all is wrong for the butcher. The animal, however well it looked on foot, is sure to be from two to three stones (28 lbs. to 42 lbs.) lighter in carcase than what it appeared, as well as deficient in quality of beef. I suppose it must be something of this sort that makes the Irish grass-fed cattle so unpopular in our markets with butchers. Notwithstanding what has been said above against Irish cattle, from what I have seen and known of their treatment during the winter months, I am disposed to take their part, and not blame them so much as their owners for the way they turn out. No doubt there are exceptions, but an Irish grazier in general makes no effort, and gives himself little concern about providing, in its proper season, a supply of winter food for his cattle. If the poor starved things survive the winter, he has no claim to any credit in the matter. Keeping the 'calf-flesh' on an animal, in the William M'Combie sense of the term, is, I fear, not well understood or practised in Ireland as it ought to be. If they, the breeders and feeders of cattle in Ireland, would take a leaf out of M'Combie's book, their cattle would be more popular, and command a much higher price than they do in all the British markets they go to. So far as soil and climate are concerned, for the breeding, rearing, and feeding of cattle, the advantages are all with them; and it is a great pity for themselves and others that they do not take the benefit of it."

It may be stated that the writer of the above remarks has, besides his experience as a butcher, an intimate acquaintance with the system of management pursued in Ireland, as he has rented, for several years, a large farm in one of the midland counties of Ireland.

Those who are accustomed to a system of cattle-rearing where the winter food consists of roots supplemented by artificial food, are aware that a given number of acres under a system of that kind will maintain a greater number of animals than would be maintained if the cattle had nothing to depend on except the pasture for their keep throughout the year. This, therefore, I believe to be the great defect in the Irish system of rearing stock. Setting aside, altogether, the fattening of cattle for the butcher during winter, and looking at it merely as a question of rearing store cattle, it is evident that a supply of winter food, such as turnips, &c., would enable Irish farmers to keep an increased amount of stock, and thereby produce more animals to meet the demand for stores, whether these were afterwards to be finished on Irish pastures or in English farm-yards. For example, on a farm in Kildare, consisting of 500 imperial acres, which has been for some years in a high state of cultivation, chiefly under a five-shift course, including two years grass, from 700 to 800 sheep are kept all the year round, more than half of which are fattening sheep, besides from 60 to 80 head of cattle, chiefly fattening beasts, and the horses required for working the farm. Under the old system, when this farm was in grass, the stock usually consisted of about 300 hoggets during summer and autumn, and six or eight head of young cattle through the winter. No sheep were kept during winter. Each of the summer-grazed hoggets required, it thus appears,  $1\frac{2}{3}$  imperial acre, while under the present system, I found, on visiting the farm, that a field of two-year-old grass, of about 40 imperial acres in extent, had kept 240 wethers of a year old from the beginning of April until October, besides six draught colts, which ran in the field for three months. The farm consists of a warm, dry, limestone soil, which produces excellent crops of all kinds, particularly of turnips and artificial grasses, but which, like much land in Ireland, is not suited to lie out in permanent pasture. Other illustrations of this point will afterwards be brought forward; but I may be permitted to quote a few very appropriate remarks, in connection with this department of the subject, from a Prize Essay by the late Mr. Thomas Barnes, the well-known breeder of Shorthorns, on "the breeds of cattle and sheep best adapted to Ireland."\* Mr. Barnes's essay was written twenty-five years ago, and referring to the introduction of Shorthorns, and some objections which were made to the breed, he said:—"There are many districts where the natural pasturage is defective, but there are few districts, comparatively speaking, where an improved system of agriculture might not supply a sufficiency of artificial food for all their wants, and no breed yet

\* 'Transactions of the Royal Agricultural Improvement Society of Ireland, for 1848.'



tried has succeeded better when house-fed and in confinement. It would be much wiser to endeavour to improve our agricultural system, and thus increase our resources, than to rest satisfied with merely what unassisted nature provides, and then waste our time in seeking for a breed of cattle that will bear mismanagement and starvation best." Since Mr. Barnes wrote his essay Shorthorns have found their way into nearly every part of Ireland, and altered materially the character of Irish cattle, but to this day there are many breeders and rearers of stock which has been improved by the introduction of Shorthorn blood, who "rest satisfied with merely what unassisted nature provides," and who are indifferent to the advantages of "an improved system of agriculture," which would, as Mr. Barnes justly remarked, "supply a sufficiency of artificial food for all their wants, and thus increase our resources."

There is a point in connection with the Irish grazier's system of cattle rearing which, I think, deserves consideration. One of the essential qualifications of the Shorthorn breed is "constitution." That the breed is capable of resisting even an inclement climate is a well-known fact, for we find that in the Orkney Islands it thrives as well as it does in Yorkshire or in Meath. At the same time the Shorthorn is an artificial breed; that is, it has been brought to its present state of excellence under conditions very different from those in which cattle exist where provision for them, in the shape of food and shelter, is left entirely to unassisted nature. How far, therefore, this comparative neglect may exercise an influence on the health of animals possessing much improved blood is a question which has not, as yet, received that degree of attention it undoubtedly merits. Will exposure to cold and continued rains, and lying for months on wet lairs, affect the respiratory organs and lay the foundation of what may afterwards become developed into serious maladies? What effect will these debilitating influences, combined with insufficiency of food, produce on the system generally? These are questions which should be thoroughly sifted, for they are of great importance in connection with the production of live stock in Ireland.

The system of rearing stock, as described, has prevailed from time immemorial, and no change or improvement has been introduced of any consequence, unless in the case of cattle and sheep which are being fattened on grass. In this instance, the practice of giving cake, or other artificial food, to stock, is on the increase, more especially in the case of stock which had been fairly wintered on turnips, but not finished. When these are turned out into the pastures I have found them, in several instances, getting cake, to push on the finish; or, as Mr. M'Combie

calls it, to give them "the last dip." On second-rate pastures, also, the cattle are sometimes assisted with artificial food, particularly when the grass fails in autumn. As I hold that this is a system which might be extended in Ireland with much advantage, I may be permitted to describe a case which shows the benefit which may be derived from it. A large grazier held a farm, upon which there was a field that had been constantly "meadowed" every summer for a series of years. Under this system the produce of the field became very scanty, so much so as scarcely to repay the expense of converting it into hay. The field could not be conveniently broken up; no part of the farm was cultivated, nor did the occupying tenant, although he held a large extent of land, possess such an implement as a plough. With the view, therefore, of improving the field in question, he had recourse to oil-cake, and during winter he put a large flock of sheep on the land, and gave them cake in boxes, taking care that the boxes were regularly shifted, until the entire surface of the field was gone over twice. Next year the grass, as usual, was saved for "meadow," and the produce in hay was double what it had been for several years previously. During the following winter the same course was followed, and next year there was a further increase in the quantity of hay obtained off the land. The cake feeding was carried out during the next two winters, with decided advantage, although the results were not, perhaps, so marked as at first; but they showed that the system proved materially beneficial in fertilizing the land. There could be no mistake in this case, because the hay was mown each summer; and besides the increase in hay there was a large profit derived from the sheep, quite sufficient to pay well for the artificial food. There is much grass land in Ireland that stands in need of improvement, and this, therefore, is a recuperative mode of effecting it which deserves the attention of those who are so placed that they cannot break up their worn-out pastures, in order to put the land through a course of good cultivation preparatory to laying down afresh.

The Agricultural Returns bear testimony to the fact that of late years a large extent of land has been laid down to grass in Ireland, and, also, that the process is still going on. A considerable proportion of the land so laid to grass was not in good condition at the time, nor were proper means taken to secure good pasture. To this point I have already in some measure referred, and it is from the defective treatment which the land received that we find so many instances of pastures becoming soon run out, or falling off rapidly in their capabilities for maintaining stock. Even when broken up, with the view to renovate them, the system which is frequently followed is far short of what the necessities

of the case require. Thus, the land is ploughed, and rape-seed is sown broadcast, assisted by a little superphosphate. The crop of rape is eaten off by sheep, and the land is then sown out with grass seeds, mostly of an inferior kind, and without any further preparation. Of course whatever weeds, such as couch, &c., exist in the land, remain where they were. A great mistake has been made in laying down so much land to permanent grass as we find has been done, say within the last 16 years; but the mistake has been rendered greater from the insufficient manner in which the land has been prepared for pasture, and from the very inferior nature of the grass seeds that have been used. Previous want of condition in the soil is easily detected, and it is especially marked where the land in former times was "con-acred." Where this was the rule the pasture to this day has a poverty-stricken, hide-bound appearance, and in some places the soil has been worn down to the gravelly subsoil, so that little grass is produced upon it.

It is necessary to explain what this "con-acre" system was, in order fully to comprehend its effect on the land. Previous to the great failure of the potato-crop in 1845-46, it was the practice with many needy proprietors and graziers to let a portion of grass-land to the peasantry in lots of a quarter, half-an-acre, or an acre, which were charged at the rate of 8*l.* to 10*l.* per Irish acre.\* Operations commenced by skinning the surface, which was afterwards burned, and, the ashes being spread, potatoes were planted in lazy-beds. This crop was succeeded by successive crops of grain—chiefly oats—until the crops became too scanty to pay the rent charged, when the land was "let out to rest," that is, to gather a surface coating of grass. When this system was frequently repeated the active soil became gradually worn away under the burning, and, although it was evidently a deteriorating system, one by which the goose was killed to get at her eggs, yet it was persevered in, simply because it brought in a large amount of cash; sums equivalent to the value of the fee-simple being often realised in the course of a few years. The lots were charged to each individual by the measurement of a local surveyor, and the owner, if hard pressed for cash, could always get an advance from some of those petty usurers who were, and are, to be found in many parts of Ireland, and who, after deducting 20 or 30 per cent. as their share of the plunder, took good care to be paid the uttermost farthing by the poor creatures who had taken the "con-acre." It was a destructive system for the owners of land, and it was a bad one for the people, nor could it have existed in

\* An Irish acre contains 7840 yards, or 1 acre, 2 roods, 19 perches imperial.

any country save in one where there was a large superabundant and unemployed population, whose chief means of subsistence were derived from the potato-patches which they procured in this way. The failure of the potato-crop in the years mentioned, and the distress which followed, put a stop to the system, but it has since been partially revived, and certain provisions relating to it were inserted in the "Irish Land Act" of 1870.

Among the causes which have led to the extension of grass-farming in Ireland, a certain prejudice against cultivation has undoubtedly exercised considerable influence. Many owners and occupiers of land were not familiar with any kind of tillage-farming save that which prevailed amongst the small landholders, and as that was evidently of an exceedingly exhausting nature; they not unnaturally became averse to cultivation. The want of practical skill in this department of rural economy, combined with the close attention which a regular system of cultivation requires, has operated materially in favour of the more simple and less troublesome system of pasturage. In carrying out that system it is not even necessary that the owner or occupier of land be a judge of stock. His Dublin cattle salesman buys what may be required to stock the land, and sells the same when fit for market; and if cash is scarce the salesman will make all straight by advancing the price of the stock he has bought, or by endorsing bills for the same, repaying himself out of the sales in autumn, and charging, of course, interest on the money so advanced. In this way the salesman has two commissions out of the stock, and good interest for his money. This practice was, perhaps, more prevalent at one time than it is now, but it is still carried on to a greater extent than many are aware of.

With reference to the influence which the freedom from close superintendence, necessary on a tillage-farm, has had on the extension of the pasturage system, the following incident, narrated by Mr. M'Lagan, M.P., illustrates one phase of the question which has been generally overlooked. Mr. M'Lagan says: "An agent told me of a tenant who had thrown all his land into grass, though the soil was not so well adapted for grass as for tillage; and the consequence was that the tenant was not so prosperous as he might have been. On the agent advising him to plough more of his land, his answer was, 'That would require too much of my personal superintendence, and would necessitate my giving up hunting.'" This, I may remark, is by no means a solitary instance of such a reason being assigned for preferring grass-farming to tillage.

During the series of wet summers and autumns which occurred 10 years ago, certain influential London papers pressed

strongly the importance of abandoning cultivation altogether in Ireland, and of turning the whole island into "one vast pasture." This view was seconded by the eloquent addresses of an eminent nobleman, since deceased, who occupied the highest political position in Ireland, and, as it chimed with the views of many who were directly interested in the matter, they proceeded, with due dispatch, to reduce these theoretical opinions into practice; forgetting altogether that, although pasturage is a most important department of farm management, it is inadequate, in itself, to increase the production of meat.

It is true that an extended system of pasturage is not a new feature in Irish agriculture. The old Irish Parliament at various times passed laws for the purpose of restricting it, rendering it compulsory on graziers to cultivate a certain quantity of land; and I believe that among the sumptuary acts passed by the Irish legislature was one which rendered it a penal offence for cattle salesmen to hold land within 10 miles of Dublin; the reason evidently being that salesmasters holding land would keep it in pasture, while the land was required to raise food for the people of Dublin; carriage of grain, &c., from inland parts of the country being, at that time, difficult and expensive. It is said that this Act is still unrepealed, but, if so, it is quite forgotten.

That a strict adherence to the pasturage system engenders a certain degree of apathy with respect to agricultural improvement scarcely admits of a doubt. This fact has been long remarked, for we find Spenser saying, "This keeping of cows is, of itself, a very idle life," while Arthur Young has put his sentiments on record in the following terms: "These graziers are apt to attend to their claret as much as their bullocks, live expensively, and, being enabled, from the nature of their business, to pass nine-tenths of the year without any exertion of industry, contract such a habit of ease that works of improvement would be mortifying to their sloth." Mr. Robert Thompson, whose agricultural 'Survey of Meath' was published by the Dublin Society—now the Royal Dublin Society—in 1802, states that "the labouring cottagers, immediately under gentlemen, generally fare better" than those who had no fixed employment, but adds in a note, "This remark does not apply to many graziers in this country, whose negligence, as to the state of their poor labourers is so apparent in the appearance of their houses and families, that a stranger visiting this country must not only wonder at their pitiable condition, but deplore the little prospect there is of amendment." Mr. Thompson, in enumerating the "Obstacles to Improvement," existing in his time in Meath, states the following, among others, as "most promi-

ment :”—“The very extensive farms, everywhere to be met with in this district, in the possession of one person, and those, too, situated in different places, and some at a great distance from the occupier’s place of residence. These, indeed,” he adds, “are chiefly occupied in grazing.”

The remarks made, with reference to this point, at that time hold good, for the most part, to the present day ; and the extended system of grass farming on arable lands must still be regarded as one of the most serious obstacles which exist to the improvement of the agricultural condition of Ireland ; and, I may add, the improvement of the social condition of the people. When the traveller visits Ireland and passes through any district where cultivation on something like a proper system is carried on, he finds the towns composed of well-built houses, full of shops amply stocked with goods of all kinds, the people employed and contented ; but, when he passes into the purely grazing districts, he sees towns and villages in a state of decay, able-bodied men listlessly lounging about the corners of the lanes, and no cheering sign of industry or vitality.

The increase of wages, which has taken place of late years in Ireland, has been frequently set forth as a reason why so much land is now laid down to grass. That wages are higher than we recollect them to have been is a well-known fact ; still, I think, the average rate does not exceed 7s. or 8s. a week. In harvest and other busy seasons the rate of wages rises very much above this ; but it must be remembered that there are many districts where there is no regular employment for labourers, except at such seasons as hay-harvest, turf-cutting, or potato-planting, so that labourers in those districts are frequently compelled to live in idleness, and they naturally seize the opportunity of “a spurt of work” to ask and get higher wages than they would expect in regular employment. The increase in the wages of labourers in Ireland, although considerable as compared with what wages were, previous to the thinning of the population through emigration, is yet much under the rates current in the arable districts of England and Scotland. And there is not so much room for employers to grumble on this score as there is on another point, which is generally complained of from one end of Ireland to the other, namely, that Irish labourers will not do as much for their wages as they were wont to do, neither are they so tractable as they were in former times. Their great object appears to be, as they themselves say, “to put in the day” with as little trouble as possible ; and yet the very men we see working in the fields in Ireland with their heavy frieze coats on, and evidently taking good care not to injure themselves with hard labour, turn out active labourers once they cross the Channel.

The remedies for this state of matters are, first, the employment of machinery as much as possible; and, next, taskwork, wherever it can be brought to bear upon farm labour. On this point—that of taskwork—I can speak without hesitation, from my own experience; and I have invariably found that where it was honestly and fairly carried out, it was decidedly advantageous both to the employer and employed. I must say I have known some instances where employers who found that men working on taskwork had made higher wages than they would have done at daywork, have cut the payment down; but any such proceeding is very foolish, for it destroys all confidence between the parties. Employers should keep in view that men working on taskwork labour far more diligently, and usually for longer hours, than they would do if paid by the day; and if a miscalculation has been made in fixing the terms for any particular job, so that the men really do make more at it than they were perhaps entitled to, it is much better not to say anything about it, but to watch the estimate of the next piece of taskwork more closely.

There is another point to which I must direct attention. In 1870 certain "Reports from Poor-Law Inspectors on the Wages of Agricultural Labourers in Ireland" were presented to both Houses of Parliament. In these Reports the Inspectors all agree that one great cause of discontent among the labouring classes in Ireland is the generally wretched condition of their house accommodation. An "Irish cabin" has long been considered synonymous with all that is squalid and miserable, and although much has undoubtedly been done of late years to improve cottage accommodation in Ireland, the evil is still far from being remedied, much less removed. Many landlords are unwilling to build cottages on their estates, dreading a return of the old cottier system; and this frequently falls heavily on tenant-farmers where cultivation is carried on. A system of tillage-farming cannot be prosecuted without a steady supply of labourers, and therefore each farm of the kind should have a sufficient number of cottages to meet its requirements. It has been suggested that the most simple way of meeting the difficulty would be, where proprietors object to build cottages, that tenant-farmers, being leaseholders, should be allowed to borrow from the Board of Works; the cottages to be erected under the superintendence of the Board, and the number of cottages on any farm to be restricted to, say, one cottage for every 50 acres. Good cottages would induce a good class of labourers to remain, who would not be satisfied with the existing class of "cabins." When a farmer has to look for labourers among the small holders around him, he never can depend upon having them when, per-

haps, he stands most in need of them, as they have little matters of their own which require their attention.

The absence of suitable buildings, fences, and farm-roads, has in many instances proved an obstacle in the way of introducing agricultural improvement; and, in such instances, has rendered grazing to a certain extent compulsory. In this, as in other matters, however, "where there is a will, there is a way," for through the medium of the Land Improvement Acts, loans may be obtained for the following purposes: The building or enlarging of farm dwelling-houses in connexion with farm offices, and buildings erected or to be erected; the erection and improvement (by alterations or additions) of dwelling-houses for labourers; planting for shelter; draining. In certain cases loans may be repaid by a rent-charge calculated at the rate of 5 per cent., payable for 35 years, instead of  $6\frac{1}{2}$  per cent., payable in 22 years. This provision extends to buildings of all kinds, clearing land of rocks, and planting for shelter. In all other cases the period of repayment is limited to 22 years.

Up to the 31st of March, 1871, the number of loans sanctioned was 4818, and the sum issued on account of works 2,142,885*l.* These totals comprise 358 loans amounting to 138,340*l.*, for the erection and improvement of farm-buildings, and 134 loans, amounting to 80,455*l.*, for the erection of labourers' dwellings, and 9 loans for scutching-mills, amounting to 2,735*l.* The total area that has been thorough drained under the Land Improvement Acts up to the 31st of March, 1871, amounted to 242,828 acres, which has been effected at an average cost of 5*l.* 19*s.* per statute acre. Of late years the extent drained annually under the Land Improvement Acts has fallen off considerably from what it was previously, which is to be regretted, as draining is one of the most important of the improvements required in Ireland.

Of late years much of the land laid down to grass has not only been sown out in an imperfect manner, both as regards the condition of the land and of the seeds used; but much of it also is not so suitable for permanent pasture as it is for rotation cropping. This last consideration has been much overlooked. People saw the better class of pastures, and they concluded that all descriptions of land would produce equally good grazing if sown out. Hence, it is frequently found that pastures do not keep the same number or class of stock that they maintained at first. This has been noticed, more especially, where young stock are grazed. In one very marked instance which came under my observation, a tract of grass land, which had originally been well laid down, had been grazed upon for a series of years by young growing cattle. The result was that, latterly, the feeding quality of the



pasture fell off to such an extent that young cattle, when taken off in November, did not show much growth or improvement from what they had exhibited when put on the grass at the first of May. The reason was evident. The phosphates contained in the soil had become exhausted by successive generations of growing animals. This process of exhaustion is going on in all parts of the country where rearing of young animals is carried on, without any attempt being made to repair the waste; and if, in any case, exhaustion is not so marked as in the instance I have mentioned, it shows the fertility of the soil, but it does not prove that the system pursued is right.

#### DAIRY FARMING ON GRASS LANDS.

Dairy husbandry is extensively carried on in the south of Ireland, as well as in other parts. The chief dependence is upon the pastures; in some districts the food of the cows is supplemented by the produce of the land, or by artificial food; while in other cases the pastures alone, with the assistance of some natural or "upland" hay, constitute the keep of the cows, summer and winter.

The county of Cork is essentially a dairy district, and in some respects the system followed is superior to that prevalent in other parts of the country.

The cows are chiefly Shorthorns or Shorthorn crosses, and the infusion of Shorthorn blood has added considerably to the value of the dairy cattle when sold as stores, or when fat. Warlaby blood is predominant, and there are several breeders in the county whose herds contain a large proportion of it. Among these are Mr. Richard Welsted, who has one of the largest herds of pure-bred cattle in Ireland; Mr. W. H. Massy, Macroom; Mr. Gumbleton, Mr. Downing, Mr. R. Smith, and Mr. James Byrne. The bull calves bred by those gentlemen have been chiefly disposed of through the district, and have thus brought the best blood into the possession of nearly all classes of farmers.

In summer the cows are grazed, being turned into the pastures the first week in May, and they are not housed until the first week in December, and in mild weather not until Christmas. Small farmers supplement the grass with vetches in summer, and with white turnips and cabbages in October and November. Within a radius of eight miles from Cork, brewers' grains and wash are freely given to increase the secretion of milk for the market. In hot summer weather the cows, instead of being sheltered, are allowed to stand in the river, if convenient, or in the drinking pond—a most objectionable practice, because, in the first instance, there is a great loss of manure when they are allowed to stand in

a river; and if in a pond, they pollute it to such an extent that the water oftentimes becomes dangerously putrid. If the cows were kept in the house during the heat of the day, and fed on green food, or even allowed the shelter of a shed in their pasture-field, this waste and pollution would be prevented, and their yield of milk would be increased.

In winter, straw is given for the first few months, and then clover hay, and finally, "upland," or natural meadow hay. A few turnips or mangolds are given to those in milk. Some farmers also give bran and ground oats in addition to, or in place of the roots. Now that both cattle and dairy produce are so valuable, prudent farmers will probably be induced to feed more liberally, using oilcake and other artificial feeding stuffs far more extensively than they have hitherto done, more especially when the breadth of land under cultivation is so circumscribed as it is at present.

Furze is much used in different parts of Ireland as food for cows, young cattle, and horses during winter. It is extensively grown in the county of Cork for that purpose, and Mr. George Bolster, an intelligent farmer in that county, states that he had much difficulty in keeping his cows through the winter on hay, pasture, turnips, &c., but since he has cultivated furze he has been able to increase his stock and have them in good condition. With the aid of furze he fed 40 cows and 8 horses at much less expense than a smaller number on the usual food, and much more profitably. The furze is given *ad libitum* after having been put several times through a straw-cutter, or, better still, through one of "Walsh's Furze Bruisers," specimens of which have been exhibited at various shows of the Royal Agricultural Society of England by Messrs. M'Kenzie and Sons, Dublin. When cows in milk during the winter season are fed on bruised furze, the milk they yield is rich in cream, and the butter is of a fine natural colour, quite different from the butter produced from cows fed on turnips.

The annual yield of milk from each cow is estimated at from 500 to 700 gallons, varying according to the breed of the cows as well as their feeding. From 12 to 14 quarts of milk produce one pound of butter. When there is no ready market for new milk it is sold at  $5\frac{1}{2}d.$  per gallon. This does not include delivery. Mr. Newnham, who has established a condensed milk and cheese factory at Mallow, Co. Cork, pays about  $6\frac{1}{2}d.$  per gallon for new milk, delivered at his place.

In large dairies the barrel churn is invariably used, worked by power, and in smaller dairies, by hand. Where only a few cows are kept, the plunge churn is employed, and the cream only is churned. The butter is packed into wooden-hooped oak vessels, named firkins, each containing about 70 lbs. In the

Cork market there are two kinds sold; one being the "heavy cured," for the foreign market, and the other "mild cured," for the London market. The heavy-cured firkins are distinguished by the hoops having the bark on them. About six pints of salt are used to cure the firkin of butter for the foreign market, and three pints for the London market.

Returns have been issued by Mr. Egan, Secretary of the Cork Butter Exchange, showing the total quantity of butter which has passed in each year through the Weigh House at Cork, from the year 1770—when the existing system of inspection commenced. The quantity which passed during the year ending 14th of April, 1871, was 389,047 firkins; but this does not show the actual extent of the butter trade of the district, as little more than half of the butter made in the county is sold through the Cork Butter Exchange, owing to markets being held weekly in all the towns.

When cows are let to a professional dairyman, where there is no market for new milk, the price paid, per cow, ranges from 9*l.* to 11*l.* The dairyman generally gets some perquisites in the shape of potato ground, and grass for the calves until the first of November. He always feeds, also, a number of pigs. The proprietor supplies hay and litter to the cows, and allows them, on an average, 2 acres Irish, or  $3\frac{1}{4}$  acres imperial per head, to keep them summer and winter. It takes  $1\frac{1}{2}$  ton of hay to winter a cow. The owner also supplies all the requisite dairy utensils. The cows are given up to the proprietor about the 1st of January, in order that they may be let run dry; and each cow for which full hire is paid must calve on or before the 15th of May. It is not considered desirable that they should calve before the 25th of March, as cows let to dairymen get little or no roots, or any feeding stuffs except hay, and if they calved long before the grass began to spring they would soon run dry, or nearly so. Farmers who treat their cows well wish them to calve earlier, as the early milk and the early calf are most valuable. It is computed that the dairyman who gains his living by hiring cows has, on an average, 3*l.* per cow for his labour. The wear and tear of dairy cattle is heavy, and it is considered in county Cork that at least 10 per cent. must be set against it.

When the cows are of good quality nearly all the calves are reared, but when they are of an inferior sort, only the cow calves are kept; the others go to the butcher, either as "staggering bob," or as fed veal calves. The calves intended to be reared are allowed to drink the "beistings," or first milk after the cow has calved. They then get new milk for the first week, and they are afterwards fed on skimmed milk. Where all, or the greater number of the calves are reared, the skim-milk is supplemented

by hay-tea and by gruel made of Indian corn ground into flour, which is far preferable to the same grain ground roughly into meal, as it becomes more digestible. Some wean their calves in August, but others continue to give them milk and gruel up to October, which is much to the advantage of the calves. Those calves which are weaned in August seldom fetch more than 4*l.* or 4*l.* 10*s.* per head, while those fed up to October realise from 6*l.* to 7*l.* per head at the October fairs. When the calves are weaned they are turned upon after-grass until winter, when they get hay in the fields. Farmers who till extensively are able to allow them some pulped turnips in addition, but, as a general rule, they are wintered solely on grass and hay. They are found to winter much better on newly laid down land than on old pastures. In the case of calves, as well as of dairy cows, it is desirable that they should get cake or other artificial food, as there is little doubt the money so expended would be found a profitable investment, now that the demand for yearlings is steady and good. The climate of the county of Cork is for the most part very mild, and hence the calves are out-fed during winter; and it is held by the Cork farmers that they thrive better in consequence than if they were house-fed, that is, if they get nothing more nutritious than hay. But, while fully sensible of the advantage of exercise for young animals, I am of opinion that calves kept in open yards, with sufficient shed accommodation attached, and an occasional run out on the grass, thrive well, while there is certainly not that waste of food which attends out-feeding, where the hay is merely thrown down on the surface of the ground, to be blown about and trampled upon.

In other districts, dairy farming is conducted in a much more primitive manner than in the county of Cork. The cows are seldom housed even in winter; and the hay they get is simply laid down to them on the surface of the pasture. It is not a pleasant sight to see a lot of in-calf cows standing during a bitter shower of sleet in March, with their backs arched, and crouching under the shelter afforded by a low fence; but so prejudiced are many of those farmers against housing their cattle, that they frequently assert it is "unlucky" to do so, and that housing causes their cows to slip their calves. There is this much to be said in favour of the outlying *versus* the housing system, that in many instances where the latter is practised to some extent, the cows will frequently be found standing up to their hocks in filth; and I have no doubt that cows so kept will be apt to cast their calves. Where there is little or no cultivation, and no properly organized staff of labour, out-feeding all the year through is on the whole, perhaps, best suited to meet the special circumstances of the case; and in the

majority of the districts to which these remarks have reference, little or no land is cultivated, except an acre or two for potatoes and wheat, or oats. Not an individual is to be seen employed in the fields, and the face of the country presents a succession of small grass fields, separated from each other by tangled and straggling hedgerows. An abundance of rushes shows that the thorough drain and its ameliorating influences are unknown; while the thistle and other weeds flourish luxuriantly. Draining, in fact, is considered injurious to the land, by taking what is called "the sap" out of it; and the entire system of management is such, that it is probably much the same as that which existed in the days when Brian Borou drove the Danes out of Ireland.

The ordinary grass-land is, in most cases, preserved for yielding a crop of hay; but on the banks of the Shannon, and other parts of the county of Limerick, there are extensive tracts of rich alluvial soil, locally known as "Corcass" land, which are reserved as hay meadows, and mown every year. When a farmer who holds "Corcass" land has more than he requires, he lets or sells the crop of grass in lots of a rood (Irish) in each lot, the purchaser mowing and making the hay, and paying from 40s. to 50s., and upwards, per rood for the grass. Until recently, those who took these rood lots were frequently persons who did not possess a single head of live stock, except, perhaps, a pig. Their object in purchasing was to rot the hay, and thus to raise a quantity of manure. The hay was put into a hole convenient to the "cabin," and all kinds of house slops and refuse were thrown over it. In consideration of the manure obtained in this manner, farmers in the neighbourhood who cultivated their land allowed the possessors to plant potatoes without charging for the ground so occupied, or, at least, only a moderate sum. This mode of manure-making has, however, become less prevalent of late years, owing in a great measure to so many of the small and medium class of farmers putting their land into grass; but for the same reason the value of the "Corcass" grass lots has been fully maintained, and even enhanced, as those farmers have no land fit to produce hay; and being without straw or turnips to fall back upon, they are obliged to depend upon a supply of hay from the rich "Corcass" land as winter food for their cattle. If they grow potatoes, the produce is consumed by their families, and any wheat they may have is grown for the purpose of turning in a few pounds of ready money.

With respect to the number of stock kept on these dairy farms, I find that on one situated near the Shannon, and having a portion of "Corcass" land for the production of hay, 38 cows

and a bull are kept on 130 acres imperial; the tillage being confined to 16 statute acres, which are kept under a succession of potatoes, and some cabbages, wheat, or oats. This is one of the best farms in the district in which it is situated. On a medium dairy farm in the same county—Limerick—which consists of 202 imperial acres, of which  $32\frac{1}{2}$  acres are kept under potatoes and wheat, or oats, the stock consists of 38 to 40 cows.

The following account of expenses and income of a county Limerick dairy farm, which maintains 30 cows, has been supplied to me by an extensive agriculturist residing in that county, who has had ample opportunities of becoming thoroughly acquainted with all the details of the system; and to show the variation in expenditure and income which has taken place of late years on such farms, he has compared 1863 with 1871, as follows:—

## EXPENDITURE.

	1863.			1871.		
	£.	s.	d.	£.	s.	d.
Dairywoman, wages and keep ..	15	10	0	25	0	0
Do. girl for 12 months .. ..	12	10	0	17	0	0
Do. do. 9 „ .. ..	9	7	6	13	0	0
Do. do. 6 „ .. ..	6	5	0	10	0	0
Herd .. ..	18	4	0	27	0	0
Coal .. ..	8	0	0	10	0	0
Firkins, salt, &c. .. ..	12	10	0	13	0	0
Depreciation on cows, and casualties	60	0	0	50	0	0
Grass and hay, at 6 <i>l.</i> per cow ..	180	0	0	at 6 <i>l.</i> 10 <i>s.</i> 195	0	0
Bull .. ..	10	0	0	15	0	0
	<u>£332</u>	<u>6</u>	<u>6</u>	<u>£375</u>	<u>0</u>	<u>0</u>

## INCOME.

	1863.			1871.		
	£.	s.	d.	£.	s.	d.
Butter, at 9 <i>l.</i> per cow .. ..	270	0	0	at 10 <i>l.</i> 10 <i>s.</i> 315	0	0
15 Calves at 80 <i>s.</i> .. ..	60	0	0	at 5 <i>l.</i> 75	0	0
Dung .. ..	15	0	0	15	0	0
15 Lambs .. ..	15	0	0	at 25 <i>s.</i> 18, 15	0	0
Pigs .. ..	2	6	6	5	0	0
	<u>£362</u>	<u>6</u>	<u>6</u>	<u>£428</u>	<u>15</u>	<u>0</u>
Expenses .. ..	332	6	6	375	0	0
Balance .. ..	£30	0	0	£53	15	0

Thus, although expenses are now considerably heavier than they were eight years ago, the income is larger, owing to the increased value of dairy produce and stock. In 1863 the balance in favour of the tenant was exactly 1*l.* per cow, while in 1871 it amounts to 35*s.* 10*d.* As a general rule, it is considered in

the county of Limerick that land which is worth 50s. an Irish acre makes the best dairy land; when the value is 3*l.* an Irish acre, the land is used for fattening cattle; while if the value is under 30s. an Irish acre, it is usually pastured by sheep or young store beasts.

A new form of dairy farming is springing up in county Limerick, and some other of the south-western districts, on small low-rented farms, especially in the hilly parts of the country, which formerly produced potatoes and oats, or grazed a few sheep or young beasts. These farms are now laid to grass, and from 3 to perhaps 5 or 6 milch cows are kept, according to the extent of each holding. Under these circumstances a system of mutual co-operation has sprung up, which is carried out in the following manner:—Three farmers, A, B, and C, club together, and one week A churns, getting as much butter from B and C as will fill the firkin. Next week it falls to B's lot to churn, and in like manner he is supplied by A and C, and so on. In some cases each keeps the price of the firkin which he has churned; in other cases they divide the money, according to the quantity of butter each brings into the general stock. The principal drawback experienced in carrying out the system arises from the quality of each contribution of butter not being always alike, and this leads to frequent quarrels among the wives; but notwithstanding this source of disagreement, the system is becoming very general in county Clare, and different parts of county Limerick. On large dairy farms in Limerick, &c., the system of letting cows to dairymen has become more general than it was at one time. On good land the price rates from 10*l.* to 12*l.* per cow. The dairyman gets grass for hay, but he is obliged to save it; also land for potatoes and oats, and a run for geese, pigs, and lambs free. The rise in wages, and the great difficulty experienced in getting skilled dairymaids, has materially favoured this system of letting cows; for the man acts as herd, and his wife as dairywoman; and if they have daughters, or other female relatives, they assist, and thus secure among themselves what would otherwise be expended in wages, while the owners of the cows are saved the trouble and annoyance of attempting to manage a lot of intractable "dairy-girls."

One of the greatest drawbacks that small farmers in all parts of Ireland labour under when they engage in dairy farming, is the want of houses of a proper description to keep the milk before it is churned. Their little barns are usually employed for that purpose; but it is impossible to preserve the milk from dust falling into it from the roofs of such buildings. This lack of accommodation renders it sometimes necessary to keep the milk in some apartment of the dwelling house, occasionally even a

sleeping apartment, which, I need scarcely say, is not calculated to improve the quality of the butter. Much of the butter made by the ordinary run of farmers is also oversalted. This reduces the value of the article. An important improvement in preparing Irish butter for market would be the use of smaller packages than the firkin of 70 lbs. If small packages were recognised in the market, small farmers would be able to fill one of these packages at one churning, which would make the quality more uniform, and therefore more valuable than it is when several churnings are required to fill the firkin. Considering that the annual yield of the milch cows in Ireland may be reckoned on a moderate estimate as representing about  $12\frac{1}{2}$  millions sterling, any measure calculated to increase the value of their produce is of much importance to the country.

Cheese-making does not form any part of dairy management in Ireland. Some farmers, more especially English or Scotch farmers settled in Ireland, occasionally make a small quantity of cheese for their own use; and in one part of the north of Ireland cheese used to be made to some extent, but it is not a common article of manufacture. I have seen as good cheese made in Ireland as could be produced anywhere; but I have also known places where the manufacture of cheese, even under apparently favourable circumstances, proved a failure. A somewhat remarkable instance of this kind came under my notice in the county of Tipperary. An experienced farmer from Cheshire took a fine farm of 500 acres in that county, intending to carry on cheese-making as he and his family had been accustomed to do at home. The pasture was excellent, but cheese fit for market could not be produced, and the attempt was given up. Yet the pasture produced butter of excellent quality, and a fair average, at least as to quantity, but the cheese was always so poor that butter had to be mixed with it. Professor Johnston says that "Whatever gives rise to natural differences in the quality of the milk must affect also that of the cheese prepared from it. If the milk be poor in butter, so must the cheese be. If the pasture be such as to give the milk rich in cream, the cheese will partake of the same quality." The instance to which I have referred is quite contrary to Johnston's views. I do not profess to be able to explain the cause, but there is no reason to doubt the correctness of the statement, for the agent on the property, who is an English gentleman and a keen agriculturist himself, was with me when I got the information from the farmer, and corroborated it. On the same day I visited another farm, held in like manner by an English tenant. It is also situated in Tipperary, but the pasture was of a "kinder" nature than that on the other farm. In this case the cheese manufacture has been perfectly successful; so much so,



that the tenant believed that cheese-making would pay him better than butter-making, were it not that butter was more saleable in the local markets, as there was a prejudice amongst grocers and provision dealers in large towns against Irish cheese. It is to be regretted that such is the case, for the retail price of cheese is much higher in Ireland than it is in England or Scotland, and the bulk of the people of Ireland are strangers to cheese as a regular part of their diet. In the early part of last summer (1871) Mr. Newenham, of Mallow, resolved to introduce cheese-making in connection with his manufacture of preserved milk. With this view he engaged an experienced cheesemaker from Somersetshire to superintend operations, and those samples of Mr. Newenham's cheese which I have seen are very satisfactory. His undertaking, as yet, is, of course, only an experiment.

I have had occasion at different times to refer to the dependence of Irish farmers on the hay-crop for the winter keep of their cattle. From such being the case, it would be natural to suppose that considerable attention would be given to the management and saving of the crop. Instead of this, we find that there is perhaps no point in which Irish farmers, generally speaking, evince more carelessness than in haymaking. For the most part the hay is the produce of natural grass, and the first mistake committed is allowing the grass to remain too long uncut. It is occasionally so ripe before the mowers are set to work, that it may almost be said to be saved "on foot." This reduces the nutritive quality of the hay, and this loss is further augmented by long exposure to the weather while the cut grass is lying in the swathe, and also when it is finally put up in field-cocks, which usually contain about 8 or 10 cwt. These are allowed to remain in the field for weeks and months before the hay is transferred to the rick; indeed, hay may sometimes be seen in field-cocks at Christmas. The result is that a large proportion of the hay at the top and bottom of the cock is so much damaged that it is properly only fit for manure. There is also a great loss of after-grass caused by this system, and the sites of the field-cocks are even visible in the pasture next season. Mr. Baldwin, Superintendent of the Agricultural Department of the National Board of Education, who has given much attention to this subject, calculates that, on an average for all Ireland, the loss sustained in the hay-crop is not under 20 per cent., or a fifth of its actual value—that is, 2,000,000*l.* are lost annually by careless management in this one point.

On those farms where a proper system of management is pursued, either rick-cloths are used or hay-barns are erected, to

which the hay is carried whenever it is fit to go into the rick. These hay-barns may be constructed in a simple manner. Thus, suppose the shed to be 50 feet long, 18 feet wide, 14 feet in height to the eaves, and 20 feet from the floor to the ridge-pole. A shed of these dimensions will afford 15,300 cubic feet of stowage room, capable of receiving from 40 to 45 tons of "upland" or natural meadow hay, when properly packed and settled.

In order to construct a shed of the dimensions given, 15 stout larch posts will be required, each 17 feet long, 3 feet of which should be charred and tarred, to prevent them from rotting. Of the 15 posts, 12 will be required for the sides, 6 on each side, placing them 10 feet apart; and at the entrance two should be fixed, 3 feet from either side, so as to form an opening 12 feet wide by 14 feet high, which is sufficient to admit a loaded cart. The remaining post is placed in the centre at the remote or other end of the shed. The posts must be set perfectly level, and cut to receive the wall-plate. This should be formed of planking, 7 inches by 3 inches; of this 136 feet will be required, and it should be well cramped and bolted at the corners, carefully jointed, and be further secured to the uprights by means of struts. These may be very conveniently formed of the over-lengths or tops of the poles, and should be nailed both to the wall-plate and the posts with strong iron spikes. When this is completed, the structure is ready for roofing, and for this 18 rafters will be required, at 3 feet apart. These rafters will be 11 feet long, measuring 5 inches at foot and 4 inches at top, by  $1\frac{1}{2}$  inch thick. An ordinary 3-inch plank, 11 feet long, will make four sides or two complete rafters, by being first cut down the centre and then on the bias, the end ones being left twice as thick as the others. The ridge-pole should be  $4\frac{1}{2}$  inches by 1 inch; and when these are all put up the structure is ready for the roofing planks. The cutting of these planks will require a little attention. They are to be cut half-an-inch thick on the inner edge, and three-quarter-inch on the outer edge. A 15-foot plank, 9 by 3, cut in this way, and allowing 1 inch for lap, will cover 50 square feet of the roofing. The roofing-planks should be of different lengths, as 9, 12, and 15 feet, so as to break the joints, and so equalise the strength of the whole.

When the planking is all laid on, the whole should be coated with tar, applied boiling hot, and in dry weather. It should be put on with a hard brush, not with a mop; and if  $\frac{1}{4}$  lb. pitch and 2 oz. of sulphur be added to every gallon of tar, they will be of much service in causing it to harden and resist the weather; a good dusting of fresh-powdered quicklime and fine sand put on while the tar is hot has the same effect.

A small king-post, supported by struts, should be added from the wall-plate to the ridge-pole, for the support of the roof in front, and at the remote end it may be stayed in the same manner. The rafters also should be secured by means of cross-braces, which will be found useful to bind the whole together. The following particulars show the cost of a hay-barn of this kind, as erected in Ireland:—

	£.	s.	d.
15 Upright posts, at 2s. .. .. .	1	10	0
Wall-plate, 136 feet lineal, at 2½ <i>d.</i> .. .. .	1	8	4
Rafters, 110 feet (plank 9×3) at 3 <i>d.</i> .. .. .	1	7	6
Cross-braces for ditto .. .. .	0	5	0
Ridge-pole .. .. .	0	2	6
Roofing-plank, 11 squares at 7 <i>s.</i> 6 <i>d.</i> .. .. .	4	2	6
Nails, tar, &c. .. .. .	1	10	0
Workmen erecting barn .. .. .	4	0	0
Total cost of erection .. .. .	14	5	10

In other cases the cost has been higher. Thus, on one farm where 4 hay-barns have been erected, each 70 feet in length, 30 feet in breadth, and 18 feet in height to the wall-plate, the cost of each barn was 42*l.* In another case, where pillars of masonry supported the roof, the cost was as follows: walls and pillars, 17*l.* 15*s.*; roofing, 28*l.* 18*s.* 2*d.*; total, 46*l.* 13*s.* 2*d.* The dimensions in this case were,—length, 72 feet; width, inside, 28 feet; height to wall-plates, 19 feet. These barns are used for storing the corn crops of the farm, as well as hay.

A light form of roofing, introduced by the Messrs. Malcomson, Portlaw Factory, Co. Waterford, has tended much to lessen the expense of hay-barns, &c. This roof is constructed in the form of a segment of a circle, having very little rise in the centre, and is formed of light wooden trellis framing, covered with a coarse calico, specially manufactured for the purpose by Messrs. Malcomson. The calico is afterwards dressed with two coats of coal-tar, applied hot. The lightness of this description of roof will be understood when it is stated that the girders and arched pieces are each 2½ inches by 1 inch, the trellis laths 2 inches by half-an-inch, and the sheeting laths 3 inches by half-an-inch in dimensions. The use of these roofs has extended very much in different parts of Ireland, and they have been applied to cow-houses and other kinds of farm-buildings, and even to cottages and dwelling-houses of a class superior to cottages. Felt may be used instead of the Portlaw calico, provided it is of the best quality. The Messrs. Malcomson construct the framing of these roofs, so that it is only necessary to set it up and cover it; and they have exported considerable quantities of the framing to different parts of Great Britain, as well as supplying the home demand.

Having mentioned the loss sustained by the ordinary practice of haymaking, I wish to call attention to a method which prevails in the north of Ireland. This is called the "lap-cock" system, and the manner in which it is conducted is as follows: If the crop is heavy a single swathe is taken, or, if light, two swathes are raked into one; and if the hay has been previously shaken out it is raked into rows equal to two swathes. The person who forms the lap-cock collects an armful, and, after shaking it up, gathers it between the hands against the knees, and by a dexterous sweep of the hand, which cannot be described, but is easily acquired, the hay is rolled into a bundle somewhat resembling a lady's muff; the joinings of the ends being next the ground. This roll, or lap-cock, is open in the centre, and does not pack together like grass in the common hay-cock, whilst the air gets through it, and the drying process goes on gradually but steadily. Sometimes the lap-cocks are shaken out, and then made into larger ones, after drying in the sun and wind; but, if the weather is favourable, the hay is frequently carried from the lap-cock without even shaking it out. I confess that when I first saw a field of hay in lap-cocks I was not in favour of it, but experience soon taught me that it is admirably adapted for saving hay in uncertain weather. I have had a crop of hay in lap-cocks exposed to almost incessant rain for more than a week, during which time nothing could be done, and yet the hay was very little damaged, because, no sooner did a breeze spring up, than the lap-cocks were rendered dry. The only thing necessary, should the weather be such as to prevent ricking, is to remove the lap-cocks during a dry interval from the spot upon which they were first laid to another spot; in fact, merely turning over is sufficient. During the hay season of last year (1871) the weather, for a considerable time, was very unsettled, but I saw a crop of upland hay saved in good condition, owing to the owner having the hay put in lap-cocks, although the field was much surrounded by trees; while hay made on the ordinary plan of the district was completely spoilt.

#### FATTENING PASTURES.

The highest class of pastures, those which will finish heavy bullocks or heifers for the English market during the summer half-year, are chiefly found in the counties of Meath, Westmeath, Kildare, Tipperary, and Limerick, more especially that tract known as the "Golden Vein," which runs through part of each of the two last-named counties. Roscommon also contains a proportion of high-class grazing land.

The best grazing lands are reckoned to carry and finish a full

grown bullock to each acre Irish, equal to 1 acre 2 roods 19 perches imperial. Some reckon a bullock and a sheep to the acre, but this is usually considered an extreme estimate. On other pastures  $1\frac{1}{2}$  acre Irish, or 2 acres 1 rood 28 perches imperial, will be required, and, in many instances, the pastures are stocked at the rate of 40 to 50 bullocks or heifers to the 100 acres Irish, or nearly 162 acres imperial. There are exceptional cases, and I have met with such in Meath, where the highest amount of stocking, as given above, has been exceeded, such as 58 bullocks being finished on 52 acres Irish. In most cases the pastures have existed for a longer period than any one can remember. The soil which produces these pastures is usually a strong, rich loam, on a limestone subsoil; but land of this description is frequently interspersed with veins of a much inferior quality, generally cold clays, or hungry gravel; and on such soils pastures deteriorate much after a time.

In general very little has been done, artificially, to the fattening grazing lands, although in very many instances it is evident that thorough draining is much required, as there are numerous marshy spots amongst the better parts of the land. Where draining has been effected the results are very striking. Rushes and other semi-aquatic plants have disappeared, and the grass on the drained parts is eaten down close, whereas, before, it never was touched by cattle until the better portions of the land were quite bare. Thorough draining is equivalent, therefore, to an increase of the feeding power of the land; and thus we find that a greater number of cattle are kept where the pastures have been well drained than could have been maintained while the land remained in its natural state.

With regard to the system of management pursued on these pastures, if we take the description given in Mr. Thompson's 'Survey of Meath,' published 70 years ago, we find much that is applicable to the present time. Thus, he says, "The first week in May graziers generally open their pastures for the admission of the summer stock, which are intended to be fed fat, as this is more a feeding than a breeding or rearing county; the lands being generally too valuable to be employed for the latter purpose, the graziers are under the necessity of going to other parts of the kingdom for the major part of the cattle fatted by them. Those beasts the graziers buy at different fairs—some in Connaught, some in Munster, and some in the neighbourhood. When brought home they are turned out into the fields where they are to be fed, and suffered to remain until fat, each field being stocked, almost from the beginning, with its full complement."

The cattle are sold during autumn, and on until Christmas. A supply of stock for the winter is purchased at Ballinasloe and other fairs in October; the stock in that case consisting chiefly of  $3\frac{1}{2}$ -year-old heifers, and 2 shear wethers. The winter stock is, of course, very light, and both cattle and sheep are run through the winter and spring on the pastures with the help of some hay. The heifers go off fat in June and July as early grass-beef, and the wethers after being shorn. Extensive graziers have generally pasture farms of different kinds, and shift their cattle from one to another, always, of course, to better pasture, and finally finish them on the best land. Some graziers grow a few acres of turnips, sufficient to finish any late fattening beasts they may have, and one grazier in Meath makes it a rule to have 100 of his best beasts finished in this way for the English Christmas markets. Graziers, for the most part, profess to dislike cattle that have been wintered even in yards, in which opinion they differ materially from the graziers of 70 years ago, who, as Mr. Thompson states, "all agree that store cattle are the better of being housed from November until the May following." Store cattle, however, that have been well wintered, are always easily disposed of in the early fairs.

The graziers in Meath sometimes run sheep with their fattening cattle, but very thinly; and many graziers are much averse to the practice, as sheep eat close, and take the sweetest parts of the pasture. Sheep do not, therefore, form so marked a feature as cattle in Meath grazing; and, in fact, a thoroughbred Meath herdsman detests sheep, unless, it may be, a few Ballinasloe wethers, which are easily looked after. Ewes give the herdsmen too much trouble, and a Meath cattle herdsman is seldom a good shepherd.

The rent of grazing land in Meath, of good quality, runs from 40s. to 72s. 6d. an Irish acre = 24s. 8d. to 44s. 8d. per imperial acre—that is, when let on lease for a term of years; but when grazing is let for a limited period, say for a year, the rent will exceed 5*l.* an Irish acre, or 61s. 8d. an imperial acre. In that case, however, the person who takes the land has no herdsman to pay, nor is he liable for public burdens, these expenses being borne by the person who has set the land.

Herdsmen are paid mostly in kind, and it is very difficult to estimate the value of their earnings. I have heard the wages of a head herdsman valued at over 60*l.* a year, but they are expected to keep two lads as assistants, and if these should be their own sons the whole of the earnings are kept in the family. For the most part they have some young cattle, for which they take grass, and, being of a saving disposition, frequently accumulate a con-

siderable amount of money. Indeed, instances are not wanting of herdsmen saving enough to buy the interest of large grazing farms, as well as to stock them, and eventually dying wealthy men.

With regard to the return from fattening cattle on grazing farms in Meath, it is expected that each head should pay 7*l.* for the summer's grass. Estimating the value of beef at 65*s.* per cwt., this shows an increase of about 2½ cwt. per Irish acre. This, I believe, is about 8 "score" to the imperial acre, which, although 3½ score above the highest produce in Norfolk,\* is below what Mr. Mechi tells us he makes off his farm, as he says, "I seldom make less than 10 to 13 scores of meat over the whole farm." Where more land than an Irish acre is required to fatten an animal, the return is of course less, and in some cases it will not exceed half the amount, per acre, as stated above. Seventy years ago, according to Mr. Thompson, heifers were expected to pay 10*s.* and bullocks 15*s.* per month for feeding.

The improvements chiefly required in these grazing districts, merely considered as such, are an extended system of thorough draining, including sinking and straightening the courses of streams which run through the lands; next, additional means of shelter; the use of artificial food as auxiliary to grass at certain seasons; and more attention to the watering-places where the cattle drink.

On the first point, that of thorough draining, I have already offered some observations. With reference to the second, namely, shelter, I would remark that out-lying cattle are chiefly dependent for shelter on hedges which are allowed to run up without being cropped. In this way the hedges frequently become thin in the bottom, and do not afford as much shelter as is often supposed. Plantations, having curved outlines, form an obvious mode of giving shelter to stock; and while many grazing districts in Ireland are quite destitute of plantations, other parts of the country which appear at a distance to be well wooded will be found deficient; the wooded appearance arising chiefly from trees growing in the fences.

It is not necessary that there should be any great expense incurred in providing shelter for out-lying stock. A simple wooden shed, having the floor paved, and furnished with a rack to contain hay, and troughs underneath, in the event of artificial food being given, is all that is required. A shed of this kind would prevent hay from being wasted, as it is when thrown down on the ground; and while useful during winter, it would be not less so in the heat of summer, a time of the year when cattle stand much in need of shelter, to allow them to rest in quiet. By giving some

\* See 'Journal of the Royal Agricultural Society,' vol. ix. p. 666.

artificial food to the beasts intended to come into market as early grass beef, their fattening would be hastened; and the same may be said of cattle which are late in being finished for market.

In order to show that such feeding is profitable in the case of out-lying cattle, I give the following statement, as supplied by Mr. Cannon, Moyglare, County Meath, of the cost of feeding a lot of heifers by him in that way. The cost is given as for one heifer:—

	lbs.
Middle of July to Middle of Oct., 90 days, 3 lbs. cake per day	270
Middle of Oct. to middle of Nov., 2 lbs. per day .. ..	60
Middle of Nov. to middle of Dec., 3 lbs. per day .. ..	90
	420
	lbs.
Middle of Oct. to middle of Nov., 2 lbs. of oats per day .. ..	60
Middle of Nov. to middle of Dec., 3 lbs. of oats per day .. ..	90
	150
	£ s. d.
420 lbs. of oil-cake=3 cwt. 3 qrs., at 10s. 6d. per cwt.	1 19 4½
150 lbs. of oats, at 8d. per stone .. ..	0 7 2
	2 6 6½
Or 5 months at 9s. .. ..	2 6 6½
	21 0 0
Value of heifer, 17th July .. ..	21 0 0
Cost of artificial food .. ..	2 6 6
	£23 6 6

The heifers so treated were sold at Liverpool on the 19th of December, in the year in which they were fed, for 38*l.* to 40*l.* each, so that even if 7*l.* is charged for the grass, the balance in favour of artificial feeding is very satisfactory, deducting, of course, cost of freight and market expenses.\*

I have mentioned the propriety of attending to the watering-places where the cattle drink, as being an improvement which is usually much required. The fields are sometimes not well watered, and when the watering-place is a pond, and not a running stream, the cattle soon render the water offensively foul. It is scarcely necessary to say that water of that kind is apt to engender disease of a fatal kind, splenic apoplexy among other maladies; † consequently, common prudence dictates carefulness in so important a matter as this. Where the water is got in a pond it is almost impossible to keep it clean, and in a case of that kind I am inclined to think that it would be better to put a fence round the pond, and sink one or two Abyssinian pumps in

\* 'Irish Farmer's Gazette,' December 17 and 31, 1864.

See 'Journal of the Royal Agricultural Society,' vol. vii. part 2, p. 443.



the field, so that the cattle would drink out of troughs. It would, of course, require constant attention on the part of the herds, to see that the troughs were kept filled. Where the water is got from a running stream the case is different. The bank on one or both sides should be sloped and paved, and if the bottom of the stream is soft, it should also be paved. Mr. J. P. Bomford has adopted an excellent plan of a watering-place at Drumlorgan, a grass-farm in the Summerhill district of County Meath. An opening 16 feet in length is made along the course of a main drain; one side is sloped down, and a perpendicular wall is built on the other, rising a little above the surface of the ground. The slope is paved; but instead of allowing the water to flow back over the stones, it is confined into a channel running along the foot of the perpendicular wall. This channel is 16 inches wide, and the water is raised in it to a foot in depth by means of a slate or a small sluice put in the outlet. The bottom of the channel is paved, and the paving stones are kept in their place by kerb-stones which are sunk lower than the paving of the channel. The kerb-stones also rise fully three inches above the level of the paving of the slope, so that in paving up to the level of the kerb-stone a depression is made in the paving of the slope at that part, which has the effect, first, of preventing the cattle from slipping into the channel; and, next, urine or other matter is caught in the depressed part, and is let off through an opening in the retaining wall built on the lower end of the watering-place. A retaining wall is also built at the upper end. There is a constant stream running through the channel, and as dirt cannot get into it, the water is always pure and wholesome.

#### GENERAL SUGGESTIONS.

Keeping in view that the production of live stock is regarded as the principal feature in Irish agriculture, and that which should be specially encouraged, it becomes necessary to consider how this can be done so as to produce the required results in the most certain manner.

Having closely watched the progress of Irish agriculture from a period anterior to "the famine," I have long been convinced that the system which has been at work in Ireland for several years is not that which is best calculated to ensure a permanent increase in the stock-producing powers of the country. This, I think, must be evident from the tenor of the remarks I have already made; and certain of the few illustrations of improved farming which will be given in a subsequent article, will tend further to support those views which I believe to be correct.

Universal dependence on grass, for the winter as well as the summer keep of stock, is, I consider, a serious mistake. In saying this, I put altogether aside those pastures which are really fattening and finishing land. These form a separate and distinct class; their capabilities may, in some instances, be susceptible of improvement, but it would be unwise to make any material change in their condition or destination. The high-class pastures form, however, but a comparatively limited proportion of the grass-land of Ireland; and a great error has been committed in fancying that land of any description, if put in permanent pasture, would do as well as the best pastures in Meath.

A few years ago, Mr. Coleman, Park Farm, Woburn, read a paper on rearing and feeding stock, before a meeting of the Central Farmers' Club. In the course of an excellent practical address, Mr. Coleman said, that "It is all very well to tell a farmer to keep four bullocks where before he had only three; but let him, before he thinks of increasing his stock, direct his attention to the production of food for them." This, Mr. Coleman showed, could only be done "by increasing both the acreage and the quantity per acre of his root and green crops."

I have quoted Mr. Coleman's remarks because they convey exactly the views I have long entertained with reference to an increased production of live stock in Ireland, and also with reference to an improvement of the quality of Irish-bred stock. The climate of Ireland, generally speaking, is favourable to the production of grass; but it is also favourable to the production of roots and green crops. Heavy crops of turnips and mangolds are produced by fair cultivation, from 30 to 40 tons of Swedes per imperial acre being by no means an unusual yield, and fully as much of mangolds. What is required in Ireland, therefore, is not alone pasture for summer feeding, but an extended cultivation of root and green crops to make up the supply when the summer food fails; and there are millions of acres scattered throughout Ireland, at present down in permanent pasture, and therefore producing only summer food, and that, too, of an inferior description, which possess capabilities for producing root and green crops that, if taken advantage of, would add very materially to the numbers of cattle and sheep bred and fed in the country.

A system of farm management which combines the production of roots along with a fair extent of pasture, is that which is best suited for a large proportion of the second-rate and inferior soils in Ireland. On such soils, for the most part, pasture does more in the way of keeping stock during the first three years than it does afterwards. A mixed system of farm management, conducted on the principle I have stated, would

give three years pasture, one year roots, and two years grain. Four years out of the six would thus be devoted to the production of food for stock, but practically the entire rotation would be directed to this object, for, unless under special circumstances, the grain grown on the farm could usually be disposed of more profitably by giving it to the stock fed on the farm, than by selling it in the public market. This, I must observe, is not a mere theoretical suggestion. It is a practice which is carried out by a number of persons who are farming at present in Ireland, and in all cases with satisfactory results.

As the best system of management for the country is a very important point, I wish to quote an opinion which will be recognised as coming from a good authority. Ten years ago, Mr. John Algernon Clarke visited Ireland as Commissioner of the 'Times,' his object being to inquire into the agricultural condition of the country at that period. That gentleman went through nearly all parts of Ireland, and in summing up the conclusions he had formed as to the special requirements of Irish agriculture, he stated that it was his "business to press the importance of enlarging the present proportion of plough land by breaking up inferior old pastures; it having been shown," he said, "that the lighter soils—embracing one-half the entire surface of Ireland, and two-thirds of the area in cultivation—would furnish more meat and store animals, besides corn, dairy produce, and wool, if farmed as a mixture of grass and tillage land, instead of being purely grazed. And this addition of 4,000,000 acres to the labour-needing area, would provide work for about 600,000 men, representing, as heads of families, probably 2,500,000 inhabitants."

What Mr. Clarke considered it his "business to press" in 1861, is as much, and even more, needed at the present time; nor will the resources of Ireland, as a stock-producing country, become developed to their full extent, until the second-rate and lighter arable soils of the country are farmed on a system of mixed husbandry "instead of being purely grazed." I might easily have quoted other practical authorities in support of the opinions I have expressed on the subject, but I feel convinced that Mr. Clarke's statement is quite sufficient for the purpose.

There is one other topic which I am anxious to notice as being intimately connected with the subject of these remarks. Before Irish cattle can reach their final destination in the English markets they must undergo the fatigue of a long journey by land and sea. That the animals suffer severely during transit is well known, and it is not necessary that I should enter into details. Their value, however, is much depreciated in consequence of the

manner in which the transit of cattle is conducted, and this is true both of fat and store stock. It is the interest, therefore, of English farmers, not less than of Irish breeders, that the transit system should be improved. Over-crowding in waggons would be prevented by a mileage rate instead of the present mode of charging by the truck, and there is no practical difficulty in supplying cattle while in the act of travelling, and confined in waggons, with water and even with food. That such is requisite will be allowed, when it is considered that cattle put into trucks at a remote station in the west of Ireland, may not, and usually have not, the opportunity of tasting water until they reach Norwich, York, or Aberdeen. Watering-troughs may be provided at stations, but most of the men employed as drovers of Irish cattle are so cruel and careless that they will not give the poor animals time to drink. Water in the waggons would of course meet this difficulty. The Select Committee of the House of Commons, appointed in 1866 to inquire into the manner in which the home and foreign trade in animals by sea and railroad is conducted, reported "that in Ireland much injury arises to cattle from bad treatment received from drovers, and that cattle landed from Oporto and Spain arrive in a better state than those from Ireland." The Committee also stated that "on the railways cattle are often over-crowded and badly treated, *especially in Ireland*," and that such treatment "causes cattle to deteriorate in value, makes them feverish, and tends to produce, if it does not actually cause, foot-and-mouth disease." The same evils still exist, and the value of Irish cattle continues to be deteriorated by a system which has been condemned by a Select Committee of the British Legislature. It is to be hoped, therefore, that public attention will be aroused to this matter, so that some radical improvement may be speedily effected in the transit of animals from Ireland; and that a system of watering, and, if required, of feeding cattle during transit, similar to that which has been recently adopted on the Austrian railways, will be enforced throughout the United Kingdom.

---

II.—*Method of Improving the Labouring Classes by altering the conditions of Poor Relief and providing them with a system of Insurance through the Post-Office.* By the Rev. J. Y. STRATTON, Rector of Ditton, Kent.

THE means of dealing with the Benefit Societies of labourers who are within the verge of pauperism have passed into a more hopeful phase than existed when the appointment of a Royal

Commission of Inquiry into Friendly Societies was urged in the pages of this Journal, in March, 1870. The Commission was obtained in the course of the following summer, and, under the presidency of the Right Hon. Sir Stafford Northcote, Bart., is now occupied with its arduous and responsible duties. Evidence has already been taken on abuses which could not be properly dealt with by other than a court of enquiry; and, if we may judge from what has already transpired through the newspapers, such evidence may not improbably furnish another and a powerful argument in addition to those which have of late enlisted the efforts of persons who are anxious to better the condition of the labouring classes, and who desire to see the plan stated at the head of this article, and partly discussed in a former paper,\* considered on its merits, and, if approved, sanctioned by the Legislature.

In a memorial † which emanated from the Friendly Societies' Committee, in 1869, and which asked for the issue of the Commission, it was stated that an investigation was required "into the bearing of the Poor Law on Friendly Societies, the means of providing insurances suited to the 'wage-paid' class, and providing for their due supervision." I shall treat the question under review in connection with the points noticed by the memorialists. It is one which will be found of great importance to those who are taking an active part in efforts for the moral and social advancement of the lower classes of the community, and not destitute of interest to the general reader.

The problem to be solved is, how to discourage and deter labourers, whose means are sufficient, if properly invested, to raise them above the condition of paupers, from common resort to the poor-rate, and induce them to secure their own provision by prudence and self-help. The solution of that problem is, I submit, to be found (1) in a strict administration of the Poor Law, and (2) by giving to labourers the means of safe investment for sums which, owing to their present view of the poor-rate, are

---

\* Vol. vi. p. 87: 'Farm Labourers, their Friendly Societies, and the Poor Law.'

† The memorial was reprinted in this Journal, vol. vi. p. 119, which see. The memorialists agreed to try for a Royal Commission of Inquiry, by which their subsequent duties would be lightened. In case they did not succeed—and their struggle would form no uninteresting chapter in the history of Friendly Societies—they agreed to collect evidence as best they could, and draw up a "digest," or report, of the same, by which means a tolerably good basis for legislative measures, if such should be needed, would, it was thought, have been secured. The advantage of obtaining such a basis from the report of the Royal Commission is admitted, and the Committee may still render good service by helping to initiate or to carry through Parliament measures for the improvement or development of insurance suited to the labouring classes, when the forthcoming Report shall enable them to proceed.

now wasted by them in various ways, among which are, first and foremost, their so-called Benefit Societies.

The fact that their contributions to such societies are of sufficient amount to secure to them support in sickness and old age, and a sum payable at death, including all fair and reasonable charges of management, is one which must not be lost sight of. It disposes of the presumed necessity of raising the wages of labourers, especially of the agricultural class, in order to enable them to save. They have the money, but no safe means of insurance in which to invest it. It is true that there are exceptional districts in England in which wages are too low to permit persons to save any part of their earnings, and the grievance is one which calls for a remedy at the hands of those who cause it. But we have to deal, not with the exceptional case of underpaid labour, but with the generality who are earning good wages. And if it is true that labourers who look on the poor-rate as a reason why they need not and ought not to save, "unless they would forfeit their rights," are spending on such unsafe refuges for poor men in distress as their benefit societies are, sums sufficient to raise them above the position of paupers, provided only that they had the means of safe investment and the will to use them, have we no claim on that assistance which might provide a security for their investments? no right to demand that all fair influences shall be used to cause them to employ their advantages for their own good? The influences can only be gained by a different administration of the Poor Law than has hitherto been common, and certain alterations in the Poor Law itself. Some strictness is required in dealing with labourers, in order to discourage and deter them from their practice of resort to the rate.

"Nor was ever cure  
But with some pain effected."

I will recapitulate, and as briefly as possible discuss, the alteration desired in the Poor Law and its administration, and then offer certain suggestions relating to the powers of the Registrar of Friendly Societies, after which the proposal to establish a system of Insurance through the Post-Office, will be described, and regulations required for its safe and proper management given.

The points relating to the Poor Law and the administration of relief are:—

I. Strict treatment of able-bodied male paupers of bad or indifferent character, thus making a difference between them and able-bodied paupers whose want has resulted from misfortune or the visitation of God.

II. Able-bodied paupers of the latter class, and aged and

infirm paupers, not to be separated from their wives on coming "into the House."

III. Relations to be compelled to pay either all or part of the cost of paupers in receipt of relief, as may be ordered after enquiry by the magistrates.

IV. Better supervision of the poor than that commonly exercised.

V. The abolition of all composition for poor-rates, and the collection of the rate to be levied on occupiers of tenements who are not excused payment.

VI. Boards of Guardians to authorise relief to applicants who belong to "certified" \* Friendly Societies, if they think the same is necessary.

VII. Boards of Guardians to refuse relief, other than the House, to applicants who belong to societies which are not "certified" by the Registrar.

A few remarks on points I. and II. may be quoted from the article already referred to:—

I. and II. With regard to idle and vicious paupers. There is, at present, no provision in our unions suited to their deserts. The cost of their maintenance and clothing should be exacted from the male paupers of this class. Retaining the power of dealing with refractory and disorderly paupers according to law, the Guardians should be empowered to draft able-bodied paupers of bad character, from among the inmates of the Union, and send them, for a stated term, to an establishment where work is exacted in return for maintenance. One such "Workhouse" in each county would suffice, and labour, both outdoors and indoors, could be found without difficulty.

But in the case of those whose want arises from infirmity, age, or misfortune, the care of the Guardians should be exercised with kindness and even some indulgence—often, be it remembered, shown at present on the worthless as well as the deserving poor. There are "able-bodied" paupers in the eye of the law who are not able-bodied in any other sense. And to them may be added those who, from natural incapacity, are ever gravitating towards the bottom, and cannot compete even in the unskilled labour performed either above or underground. It is further germane to the improvement of the poor that a reform of the law in points in which it is at variance with laws designed by the Creator for the good of the human race should be made. The regulations which separate husband and wife, parent and child, which break up families, are perpetuating worse evil than is inflicted on those who are thus put asunder.

---

\* The term "certified" will be explained below.

“Results of this unnatural law are plainly and sadly traceable in the brutality of husbands towards their wives and families, in the relaxation of family ties, in the unfilial and undutiful conduct of the son who will leave his widowed mother to end her days in the workhouse, and will refuse, unless compelled by law, to contribute a farthing towards her maintenance. It is true that the Act makes a distinction between able-bodied married people, and married people who are infirm from age or other cause. With respect to the former, if there is good reason why a man crushed by adversity, and not by vice, should desire the consolation of his wife, instead of being compelled to separate at the time when mutual support is most needed; if it is true that the anguish of being parted is but keener in the female mind—then let us not continue, for the sake of a neat system of regulating the inmates of the Union house, to augment the distress of the poor by such forced separation.” With regard to the permission for infirm married people to live together, we believe that it is seldom, if ever, carried into practice. How can we hope for moral and social advancement among the poor so long as our regulations are opposed to those which God has ordained for the good of mankind? The mischief extends far beyond its immediate victims: it affects the mass of labourers, by degrading in their eyes the bond of matrimony, and impairing the influences of family affection. And will it be seriously maintained that the labouring classes are the only sufferers?”

III. As to the third point, it is only necessary that the Board should carefully set the law in motion, and in this respect the rule adopted by the Guardians of the Union of Upton-on-Severn should, I think, be generally used. It was stated at the recent Conference of Chairmen and Vice-Chairmen of Guardians held in London, Earl of Lichfield in the chair, by Sir Henry Lambert, a member of the Upton Board, that “they had done all they could in the way of investigation, and he knew pretty well the condition of nearly every one in the Union. Where applicants had relatives or friends able to support them, they were, if necessary, brought before the magistrates, and whether the application succeeded or failed *it had a beneficial effect, seeing that at least it compelled those who were legally liable to support relatives to explain publicly in court why they did not do so.*” I was sorry to hear from the same speaker that in other important respects the Poor Law was so badly administered in that Union. It is, however, no matter of surprise when *the official members of that Board appear with two or three exceptions, to take no part in the management!* In the report recently made public of the “Poor Law system of Elberfeld,” the Prussian law, “which imposes the obligation of supporting relatives in a much wider sense than does our statute of Elizabeth,” is stated to be rigidly enforced.\* “Nowhere is the legal obligation of supporting relations, especially the duty of children to contribute to the support of parents, more rigidly enforced than in Elberfeld. . . . A person who is by law liable to contribute to the support of a relation, and, being able,

\* Report to the Right Hon. J. Stansfeld, by A. Doyle, Esq., Poor Law Inspector.



neglects upon being called upon to do so, is, if the relation become chargeable, liable, by the police regulations, to imprisonment during such time as the relief might be required." The "Instruction" enjoins on "overseers and visitors" to impress and enforce this duty (the legal obligation of supporting relatives) upon all occasions.

IV. Better supervision of the poor than that commonly made is also needed. In a paper\* read at the Conference of Chairmen and Vice-Chairmen of Boards of Guardians in London last November, allusion was made to the mistaken "economy of having an inadequate staff of relieving officers. Sir Charles Trevelyan, Sir Baldwyn Leighton, Mr. Smith, M.P., and other speakers, were in favour of careful investigation and scrutiny of the out-relief lists." Bearing in mind that the test of "the House" is not yet used in Elberfeld, the reader will be interested to notice the substitute for such test, and a few hints may be extracted therefrom which will be useful in dealing with our own applicants for relief:—

"The applicant is subjected to an examination so close and searching that no man who could possibly escape from it would submit to it. He is not one of several hundreds who can tell his own story to an overworked relieving officer, but one of a very few, never exceeding four, frequently the single applicant, who is bound by law to answer every one of that long string of questions that his interrogator is bound by law to put to him. . . . He must state whether he has a settlement in Elberfeld, that is, whether he has resided in it without receiving relief for 12 months, how long he has resided in it, where he resided before, . . . he is bound to give, with his own name, the name of every member of his family, the day, month, and year of the birth of each, his birthplace, religious profession, . . . his occupation, the name of his employer, his average weekly earnings; he must declare whether his family leads a moral and honest life, specify which of the members does not, . . . the name, dwelling, business, and circumstances of surviving parents, parents-in-law, and grandparents, as well as children not living with the head of the family. The applicant is bound to give 'the causes of his pauperism.' This is no superficial inquiry in which he can palm off some plausible story of distress, and the cause of it, but is a strict investigation into the circumstances of the man's life and present position. After the claim is admitted, the pauper is kept under constant *surveillance*; he is urged to find work, and, if he cannot find it, labour is provided for him."

While I admit that it would not be possible to adopt the system of Elberfeld in this country, there are many Guardians who might most usefully aid the labours of the relieving officer by instituting strict inquiry in addition to that made by the servants of the Board, and who, by impressing on the labouring class the duty of maintaining their relations, would raise in some degree their moral perception as to their duty.

V. On the fifth point, of abolishing composition in lieu of

\* By Rev. Septimus Hansard.

rates, it may be noted that the questionable privilege of the Small Tenements Act has done mischief in country districts. It has given rise to the abuse known as "farming the rates." The owner pays say 4s. a year in lieu of rates, and charges his tenant 4d. a week in the rent. It is no wonder that intelligent labourers consider that a grievance is thereby inflicted on them for which their redress is to get as much as they can from the rate. Where the Act is in force the poor are in favour of rate plunder, and do not care how many rates are made in the year. Where they are compelled to pay the rate as the same is due and payable, it becomes, in their opinion, a matter of consequence to have the rates as few and far between as possible. Such legislation strengthens them in their vicious hold on the poor-rate.

VI. and VII. We come, in the next place, to the treatment to be adopted in the case of members of Friendly Societies claiming relief. A difference should be made between members of Friendly Societies approved by the Registrar and those who belong to societies, the rules, regulations, and accounts of which will not pass the examination of that officer. In the latter case the applicants should have nothing but the offer of the House. This treatment would strike a blow at all Benefit Societies which have been framed with special reference to leaving their members sooner or later to the poor-rate, and would compel their members to re-form the Societies on a proper basis, or to forsake them for better. Societies which cannot be dealt with by the law may thus be reached by the Guardians of the Poor. For the purpose of distinguishing between Societies to be encouraged and those which should be discouraged by the Guardians, the Registrar's certificate should be made a testimonial, not only that the rules are in conformity with the law, but that the society is a *bonâ fide* provident institution.

Thus far with regard to the Poor Law and its better administration. In corroboration of the views expressed in this article as to the power of influencing labourers through the Poor Law to cultivate provident habits, I may refer to the results which appear to have been realised already at Elberfeld, though it is to be regretted that fuller information was not collected on this part of the subject by Her Majesty's Inspector. "The general opinion," that gentleman reports, "of those persons whom we had an opportunity of consulting is, that the system of Poor Law administration has had a marked effect upon the habits of the people, inducing much greater thrift and providence. This seems to be confirmed by such returns of Benefit Societies as we had access to. The number of contributors appears to increase steadily from year to year."

I will now consider what powers should be given to the

Registrar of Friendly Societies in order to enable him, in addition to his present functions, to give the assistance desired.

On the death of Mr. Tidd Pratt the proposal to transfer the duties of the certifying officer to the Board of Trade was embodied in a Bill brought in by the Chancellor of the Exchequer, Mr. Lowe. The Bill, however, was withdrawn, and the effort made, probably with a view to lessen the expense of the Registrar and his staff, proved abortive. I am not surprised that this course was taken, and while admitting that the duties of the Registrar might be fairly discharged by a department under the Board of Trade, think that it is for the public good to keep the registration of these Societies separate and independent of any other department, and increase the powers of the Registrar. To enable that officer to give a certificate of any practical value, he should have—

(1) Actuarial assistance as he may find necessary for the purpose of examining the financial position of Societies once in three years ;

(2) Auditors for the purpose of examining the annual accounts of Societies ; and

(3) Lastly, an officer for prosecutions in cases of fraud.

The cost of valuation and audit should be defrayed by the Societies, and, without going into the question of costs at length, it is not unreasonable to state that it could be easily defrayed by them. Although valuation commands at present high payment, it can be, and ought in all cases of Friendly Society insurances to be, done at a remunerative price far below that commonly charged by the actuary. We believe that no special charge is made in the Manchester Unity for information to "courts," as to their financial position, from the central authorities. There can be no question that the managers of Societies would gladly pay in order to secure from the Registrar of Friendly Societies such advice as the district officers of the Unity may have for nothing from the corresponding secretary of that institution ; and the same remark will apply to the cost of auditors. Forms, which the actuary would prepare, should be supplied by the Registrar to all Societies where his certificate was requested, both for the annual audit and the triennial valuation. The officer to prosecute should however be paid by salary as the Registrar is paid, expenses of prosecution being charged as ordered by the Judge in the County Court or the Justices of the Peace. The higher class of Societies, such as those intended for the industrial class, would turn the advantages of valuation and audit thus offered to them to good account, and in many cases would, we believe, be placed in the right way to secure solvency. The Societies common among the labouring

classes would have the opportunity of the same assistance, and would seek the advantages of the certificate of the Registrar, not only as a proof of their trustworthiness, but as giving their members the advantage of being able to obtain relief other than the House.

The Registrar would prepare—

(1) A schedule of all Societies whose assets were found to be greater than their liabilities at the last preceding valuation, and whose accounts were passed for the year, and should certify the same, and that their rules were in conformity with the law.

(2) A second schedule, viz., of Societies whose liabilities were greater than their assets, or accounts badly kept, stating that they were debarred by such cause from his certificate. These, with all Societies which decline the registry, should be considered Societies which do not fulfil the requirements of the Registrar, and rank as uncertified Societies.

These schedules should be appended to the Registrar's annual report, which should be published so that the Guardians of every Union might have the means of referring to such source of information respecting the Friendly Society, any member of which is an applicant for relief. The Guardians would by such assistance be able to deal heavy discouragement on the Benefit Societies which, in their formation and management, keep the poor-rate in view.

We now come to the question as to the course which legislation should take in providing a system of insurance suited to the labouring class. That they can be coerced by law into leaving the pauperising club and joining a better, or even reforming what they have, is not possible; but a safe and easily understood system of insurance, offered them at a cost not greater than they are paying for "benefits" already, while their grip on the poor-rate is resolutely shaken off by the Guardians, would involve no invasion of their rights and liberties, but would confer on them great advantages; and, by enabling them to win their independent maintenance by their own prudence and exertion, it would materially advance their moral and social welfare.

Give to labourers, not debarred by age or infirmity, the free offer of joining a safe and well-managed provident institution at a price they can afford to pay for the same, administer the Poor Law in the manner above discussed, and it will then be their fault, and no longer their misfortune, if they do not improve their position.

Effort has already been made, and, I regret to say, without success, to induce the authorities of the Post-Office to obtain certain alterations in the Act which enables them to grant insurances, and thus empower the Post-Office to undertake the

management of such a system. And inasmuch as the Post-Office possesses the machinery necessary for the work, and has sought to bring safe insurance within reach of a portion of the labouring classes—though not reaching down to the stratum occupied by the labourers within the verge of the rate—I am only pressing the question to its logical conclusion in submitting that the insurances required may properly be offered to the country under its management and by its means.

In 1867 a memorial from the County of Kent Friendly Society, supported by several Boards of Guardians, clerical associations, and agricultural societies in Kent, was presented by a deputation, headed by the Earl of Romney, to the then Post-master-General, the Duke of Montrose, K.T. The memorialists stated that, by means of an extension and adaptation of the Act 27 & 28 Vict., c. 43, a system of insurance suited to the requirements of labourers could be obtained under the supervision of Government and by means of the Post-Office, by which labourers might secure, by a single policy of insurance, sickness-pay from 6s. a week and upwards, together with burial-money from 5*l.* and upwards, which they accordingly asked for; and, further, that the insurances known as Endowments might be granted by the Post-Office. The memorialists made no allusion to the provision of old-age-pay, considering that, with some alteration in point of detail, the same might be offered with advantage to the labouring classes under the powers already obtained under the Act.

The original promoters of this Act had been among the first to recognise the advantages easily attainable by employing the Post-Office as the avenue by which safe insurances should be offered to the industrial and labouring classes; and it is impossible to overlook these advantages in extending the benefits of the Friendly Society in such a form as will confer substantial good on the classes who, as yet, have not been reached by them.

This proposal, which was discussed by me in a pamphlet, reprinted almost *in extenso* in the Report of the Royal Commission on the employment of young persons, women, and children in agriculture, and recommended as “deserving further attention,” I again urge on public attention, and now proceed to state the cost at which the following insurances may be offered to the public, viz. :—

(I.) Sickness-pay and burial-money, in a single assurance, as is the common use in Benefit Societies. (II.) Annuities and (III.) Burial-money to be offered as separate insurances. There are persons who would be glad to secure the sickness-pay, burial-money, and the annuity by one policy, and so pay for the three benefits in one contribution, due from month to month. Such facilities should be afforded them.

I will, in its place, describe the endowment insurance.

I. *Sickness-Pay and Burial-Money.*—The following rates are sufficiently high to secure solvency in an institution insuring sickness-pay and burial-money to persons employed in “heavy and light labour.” They compare favourably with the contributions paid by such persons into unsound and pauperising Benefit Societies.

TABLE OF CONTRIBUTIONS.

For Males 25 years and under, for Sickness-Pay till 70, and Burial-Money; and for Males between the ages of 25 and 35.

CLASS.	PAYMENT PER MONTH.		Sickness-Pay Per Week.	Burial-Money.
	Age 16 to 25.	Age 25 to 35.		
	<i>s.</i>	<i>d.</i>	<i>s.</i>	<i>£.</i>
1	0	8	4	3
2	1	0	6	5
3	1	4	8	6
4	1	8	10	8
5	2	0	12	10
6	2	3	14	10

Example: A. B., aged 25 years, insures for the 5th Class; viz. 12s. per week in sickness and 10*l.* at death. For this he will pay 2s. a month, or 1*l.* 4s. a year.

C. D., aged 26, will pay for the same 2s. 7*d.* a month, or 1*l.* 11s. a year.

Much inkshed has taken place over the necessity for a graduated scale, and to little or no purpose so far as this proposal is concerned. For labourers insure at a very early age, usually, it is said, before they are 20 years old; and provided that they could join an institution which would not break down and set them adrift and in search of a new society before they were many years older, we should not have heard much of the graduated scale for sickness insurance. An institution undertaken by Government would be as safe as the country could provide. We should desire but 2 rates of monthly contributions, as shown above, the one being for persons below 26 years of age, and the other for persons 26 and below 36. The advantage of joining before the insurer is 26 years may be seen on reference to the above example; A. B. would save 7s. a year, as compared with C. D.

And the age, 25, taken for this inducement is not a bad time when it may be applied, though it might be well to take an earlier age. I have, however, been somewhat led by the desire not to exceed a decennial period for the higher grade, and it would

not be desirable to exclude men of 35 years from the benefit of sickness-pay.

II. *Annuities.*—In the next place the means of securing an Annuity should be placed within the reach of labourers. It may at first sight appear a miserable pittance for the poor to say that an annuity of 10*l.* or 12*l.*, commencing at 65 or 70, according to choice, is giving him independence in his old age. But 4*s.* or 5*s.* a week will compare favourably with outdoor relief, and outdoor relief will not be so easily stopped as may be desired.

Many a man is hale and hearty till far beyond 70 years of age, and worth his 1*s.* a day at his work. It would conduce to such a man's health and longevity if he could take his work pretty much as it suited him. Many labourers, with a provision of this sort to fall back upon, with money payable at death, would be kept altogether from resort to the rate; and even when totally incapacitated from work, relatives who would barely have him on the outdoor allowance of 2*s.* 6*d.* per week will make him pretty comfortable on his annuity.

Let us next consider what may be done for him to enable him, having reference to his means, to secure this benefit.

The Tables published by the Post-Office, do not, at present, offer annuities commencing at 70 years of age; but I presume that no insurmountable difficulty is in the way of such a benefit being obtained. I shall, therefore, not quote their Tables, but subjoin an estimate which might, if necessary, be used.

A man of 25 may secure 2*s.* a week at 65 or 70, money not returnable at death:—

Age.	Monthly Contribution for 65.		Monthly Contribution for 70.	
	<i>s.</i>	<i>d.</i>	<i>s.</i>	<i>d.</i>
25	0	7	0	4
26	0	7½	0	4
27	0	8	0	4
28	0	8	0	4½
29	0	8½	0	4½
30	0	9	0	5
31	0	9½	0	5
32	0	10½	0	5½
33	0	11	0	5½
34	0	11½	0	6
35	1	0½	0	6½
36	1	1	0	7
37	1	2	0	7
38	1	3	0	7½
39	1	4	0	8
40	1	5	0	8½
45	2	1	1	0
50	3	3	1	6

And so in proportion for 4*s.*, 6*s.*, 8*s.*, &c.

Example: A. B. is 30, and insures for 6*s.* at 70. The monthly

contribution 1s. 3d., or 15s. a year. If he insures for 6s. at 65, the monthly contribution 2s. 3d., or 27s. a year.

Example: C. D., aged 35, insures for 4s. a week, to commence on his reaching the age of 65. The monthly contribution is 2s. 1d., or 25s. a year. If he prefers to take his chance as a workman till he reaches 70 years of age, and then to commence his old-age-pay, when his sickness-pay will cease, he will have to pay for the same 1s. 1d. a month, or 13s. a year.

It may be remarked that as sickness-pay is taken in the foregoing to end on the members attaining 70 years of age, we have then a convenient time for the annuity to commence. A labourer 35 years old, or near that age, has, if prudent and diligent, commonly the means to increase his insurance. His little ones have by that time begun to be less of a strain on his means; and once let him fully appreciate the advantages of thrift, and the disadvantages of becoming a pauper, the provision of old-age-pay will become to him a matter of great importance. For 16s. 3d. a year he would be able to claim 5s. a week for life on reaching 70; for 19s. 6d. a year, 6s.; and there are numbers of such men who will find the money, once give them the means of investing it for their provision, and the necessary schooling from a better administration of the Poor Law.

Any able-bodied labourer of ordinary industry and skill, and in good health, living in a district in which wages average from 2s. 3d. to 2s. 6d. a day, would be able to secure by joining at, or under

	£.	s.	d.
25 years of age, 12s. a week in sickness till 70 years old, and 10l. at death for .. .. .	1	4	0 a year.
And, at 35 years of age, 5s. a week for life on reaching the expiration of his sickness-pay insurance, viz., 70, for .. .. .	0	16	3 a year.

Total cost per annum    2   0   3

There can be no question about the ability of labourers in such localities to pay from 2l. to 3l. a year, because they are already paying as much into their clubs. And in localities in which wages are low, and wherever labourers are in the habit of joining Benefit Societies, we shall find that they will be able to secure a higher amount of sickness-pay and burial-money than that which they are at present able to get, together with an annuity, which, though small indeed, and not what we could wish it to be, is better in every sense than letting these poor people drag a scanty maintenance out of the poor-rate. But supposing for the moment that they could not save, the existence of their misfortunes should not be allowed to debar the mass of labourers who are better paid from having the power given them of



securing their independence by their own exertion,\* and from being encouraged and influenced to secure it.

These insurances of sickness-pay and burial-money are taken for persons engaged in light or heavy labour, and not for cases in which there is more than ordinary risk. A percentage, to be settled by the value of the risk, must in such cases be added, and until such value can be ascertained with accuracy, we would decline all proposals for sickness-pay and burial-money from persons exposed to extra risk, taking of course their proposals for annuities.

A rule may be given, for the purpose of dealing with members suffering under chronic and confirmed illness, to the following effect:—In case any member shall be disabled by loss of limb, or by blindness, apoplexy, palsy, or other injury, disorder, or disease, so as to be permanently incapable of any kind or sort of profitable employment, and such disability or incapacity be proved to the satisfaction of the Postmaster-General; then such member shall receive a weekly allowance so long as sickness-pay is due, not exceeding half the amount of sickness-pay contracted for, and not less than one-fourth of such amount. Should he recover, he shall be placed in the same situation in which he was when a healthy member, and his allowance as above shall in such case be withdrawn. In case of any member insured for sickness-pay being disabled by any sickness or infirmity which appears likely to disable him from following his usual employment, or any other profitable labour, the Postmaster-General shall have power to make an agreement with him for a weekly allowance to be paid to him in lieu of sickness-pay otherwise due, for a term, so that he may be, by such composition, at liberty to engage in easy work, at the expiration of which term he shall have no further claim on sickness-pay.

The foregoing manner of dealing with such claimants, among whom will be found, if anywhere, the “malingerers,” for whom the term should made of the briefest, and the persons who have a fair claim on relief or maintenance from the poor-rate, which in their case can entail no degradation on them, disposes of the difficulty of dealing with this class of illness.

---

\* It is no part of this paper to deal with the wages question. Like other social problems, an investigation would show that there is another question underlying it which must be dealt with before the wages can be placed on a satisfactory footing. Where land is badly cultivated, from the system of small and penniless tenants, who scrape as much as possible out of it towards the end of their term of occupation, and “put nothing on,” we find that both landlord and labourer fare badly. It would be well if such tenants could be gradually got rid of; and the employment of more capital in agriculture is tending, though but slowly, to such an improvement. They would be better off as labourers than as tenants, both in point of less anxiety and less work.

III. *Burial-Money*—The following table gives the monthly contribution at various ages for 10*l.*, from which the rates for 5*l.*, 20*l.*, 30*l.*, 40*l.*, and 50*l.*, may be easily reckoned.

TABLE OF CONTRIBUTIONS FOR BURIAL-MONEY ONLY.

AGE.	Monthly Contribution.	Amount.		
		<i>s.</i>	<i>d.</i>	
Between 17 and 25 years	0 4	} 10	0	0
„ 25 „ 30 „	0 4½			
„ 30 „ 35 „	0 5			
„ 35 „ 40 „	0 6			
„ 40 „ 45 „	0 7			
„ 45 „ 50 „	0 8			
„ 50 „ 55 „	0 10			

A few rules for the due administration of the Post Office Friendly Society, adapted from various sources, are subjoined. Rules required for the regulation of officers, whether at headquarters or in the districts, are purposely omitted from this paper.

## CERTAIN RULES AND REGULATIONS.

The stock or fund of Insurances, viz., sickness and old-age-pay, and endowments, shall alone be liable to make good the Insurances made in it.

The benefits to be contracted for in the Post-Office Friendly Society shall be as follows:—

(1.) Weekly sickness-pay to the age of 70 years, in connection with burial-money. (See Table at p. 86.)

(2.) Weekly old-age-pay from and after the age of 65 years.

(3.) Weekly old-age-pay from and after the age of 70 years. (See Table at p. 87.)

(4.) Burial-money or Insurance on life. (See Table above.)

(5.) Endowments or prospective provision.

Following the above should be the Table of contributions for sickness-pay and burial-money, at p. 87.

Each member may be required to purchase a book of the rules and regulations.

*Sickness-Pay and Burial-Money.*

A policy describing the benefits insured for shall be delivered to every member on the completion of his policy and receipt of the first monthly contribution; the same to be printed on cardboard or stout paper. Ten inches by six will be a convenient size, and it should be as follows:—

No. . . . . POST-OFFICE FRIENDLY SOCIETY.  
 District . . . . . s. d.  
 A— B— of C—. . . . . Monthly Contribution . . . . .

This is to certify that you, the aforesaid A— B—, were this day admitted a Member of the Post-Office Friendly Society; and that you will be entitled by right of this Insurance to receive out of the Funds thereof [*six months after this date or immediately*] the benefits of the Class Sickness-pay and Burial-money.

Viz. } Shillings, weekly Sickness-pay till 70.  
 } Pounds, Burial-money, to be paid at your death.

Provided always, that nothing which you have stated touching your age, or health, or constitution, in the answers signed by you in your proposal to make this Insurance, shall be found untrue; and that a first monthly contribution as above, due this day on account of this Insurance, and a like monthly contribution to become due on the . . . . . of every month until you shall be 70 years of age, shall be duly paid; and that this Insurance shall be subject to the rules and regulations of the said Society in every respect.

Signed . . . . ., this . . . . . day of . . . . . in the year . . . . .  
 Examined . . . . .  
 Entered . . . . .

(Stamp of the District Office where payments are to be made.)

No person shall make any insurance for sickness-pay by which he will receive more than  $\frac{2}{5}$ ths of his average weekly wages, under liability of forfeiting all moneys paid on account of his insurance.

\* Members are to give notice of change of district, in order that their insurances may be transferred to the district in which they are going to live.

\* Contributions to be paid monthly, or, if the amount is not less than 2s., the same may be paid twice a month, viz. on day in the first and third weeks of the month. Every member shall have a contribution card on which the officer shall note the date of receiving and the amount of the contributions, and initialise the entry.

Benefits not to be due till six months after admission, unless six monthly contributions are paid on admission.

\* Sickness-pay shall be of two kinds, full-pay and half-pay. Full-pay sickness shall be a state of total and undisputed incapacity, by reason of illness or injury, to do any work whatever.

\* When a member is sick, and proceeds to claim weekly pay, he shall send notice of his sickness to the Postmaster of the district in which he resides. One week's sickness-pay shall be due to the member on the expiration of one week from the day upon which the notice of sickness was received, and the second week from the day on which the first week's sickness-pay was due, and so on week by week, and shall be paid in a way convenient to the member.

\* Medical evidence to accompany the notice, otherwise the notice is invalid.

A written notice of recovery to be given, under a penalty of 6d. a week in case of delay.

No sickness-pay shall be due to any member who is suffering from any disorder or disease which he had, or which he knew himself by previous experience to be more than commonly subject to, and which he, on admission, wilfully concealed. No sickness-pay shall be due to any member on account of sickness or injury arising out of profligacy, drunkenness, quarrelling, or any act contrary to law. No sickness-pay to be due to any member who is under confinement for any offence against the law.

Sickness-pay shall not be due to any member who enters Her Majesty's Army or Navy, but all moneys paid by him, with the exception of the first monthly contribution, shall be returned on his entering such service.

Sickness-pay shall not be due to any member who changes his occupation for one in which the risk of health is known to be higher than that insurable by the Post-Office, unless notice of such change has been given, and the value of the risk added to his monthly contributions.

Sickness-pay shall be suspended when any member refuses to be seen by any officer appointed to visit him by the Postmaster-General or to answer reasonable questions respecting his health.

It shall be suspended when the sick member shall have been drinking in or on the premises of any public-house or beer-shop, or shall have been intoxicated in any case.

It shall be suspended and be liable to forfeiture, together with all rights of the insurance, in case of an attempt to impose a claim on the officer; and in the event of such claim being proved fraudulent, and a payment made on it, the member shall be liable to proceedings.

Half-pay sickness shall be a state of inability, by reason of bodily injury or sickness, to engage in, or to follow, the usual occupation, and shall be permitted to a member on his being in a fair way of recovery from sickness, for which he had claimed full-pay. And whenever there shall be a change from full to half-pay sickness, the member shall give notice of the same, otherwise he shall not receive pay for such sickness.

When any member shall have received weekly full sickness-pay for 52 weeks in the aggregate, he shall not be entitled to more than such an allowance weekly as the Postmaster-General may allot to him.

#### *Burial-Money Insurance.*

\* If any false statement concerning health and constitution shall have been wilfully made at the time of making an insurance.

the insurance shall be liable to forfeiture on account of such false statement.

If any member die out of the United Kingdom no burial-money shall be paid.

If any member shall die by suicide, or while engaged in any illegal act, his burial-money shall be forfeited.

Burial-money, when not exceeding 50*l.*, payable to the widow or child, if only one, or if children, to such children in equal parts, or if no issue, to his father, and if there is no father, to his mother, and if there is no mother, then to his surviving brother or sister, or brothers and sisters, if more than one, in equal shares; and if only one the whole to such one; and if there be no brother or sister, then to the person or persons who shall appear to be entitled to receive the same under the Statute of Distributions.

But a member may nominate any person to receive the amount insured, and his nomination, in order to be valid and effective, shall be signed by the member making it, and his signature attested by at least one witness, whose residence and calling shall be fully described. It must be forwarded to the Postmaster-General, and may be revoked on payment of \_\_\_\_\_, and another nominee substituted. If the nominee die before the money is claimable, no payment shall be made for the nomination of another person.

\* If any contribution shall be one month<sup>y</sup> in arrear, the member shall be fined on the following scale:—

For every 6 <i>d.</i> in arrear of 1 month, fine .. .. .	..	..	..	..	..	<i>d.</i>
" " 2 " .. .. .						¼
" " 3 " .. .. .						½
						1

If the arrears exceed three months the insurance shall be liable to forfeiture, and shall be forfeited unless the member is able to show satisfactory cause to the contrary.

When a labourer wishes to join the Post-Office Friendly Society, he must apply at the office of the district in which he resides, where he will receive from the officer a paper for him to fill up, or which the officer is to fill up for him, and see that he attests the statement by his signature or mark. The declaration paper should be as follows:—

I \_\_\_\_\_, of \_\_\_\_\_, in the district of \_\_\_\_\_, do hereby propose to the Postmaster-General to make an Insurance in the Post-Office Friendly Society for benefits in the \_\_\_\_\_ Class Sickness-Pay and Burial Money.

Viz. } Shillings per week, Sickness-Pay till 70.  
 } Pounds Burial-Money.

And I hereby declare that the statement herewith, and my answers to the

\* To be printed at the back of the Policy.

questions following, are to the best of my knowledge and belief correct, and that they shall form the basis of my contract with the Postmaster-General.

Witness my hand this \_\_\_\_\_ day of (month and year).

I was born at \_\_\_\_\_, in the County of \_\_\_\_\_, on the \_\_\_\_\_ day of \_\_\_\_\_, in the year 18 \_\_\_\_ . My usual calling or occupation is that of a \_\_\_\_\_, and my usual weekly wages are not more than \_\_\_\_\_ shillings.

*Questions.*

1. Are you of sober and temperate habits?
2. Are you now in good health?
3. Have you been a whole month sick within the last 3 years, and, if so, when?
4. Have you had gout, rheumatism, spitting of blood, rupture, palsy, fits of any kind, or asthma?
5. Who is your medical attendant?
6. To whom do you refer for character?

*Answers.*

Proof of age, either register of birth or of baptism, or other satisfactory evidence, shall be appended to the proposal paper.

In case the proposer should desire to insure at the same time for old-age-pay, he shall fill up the following Form:—

*Old Age Pay.*

I, \_\_\_\_\_, do also propose to make an Insurance for \_\_\_\_\_ shillings weekly, to be due to me after the age of  $\left. \begin{array}{l} 65 \\ \text{or} \\ 70 \end{array} \right\}$  years, and I am willing to pay \_\_\_\_\_ per month for the same till  $\left. \begin{array}{l} 65 \\ \text{or} \\ 70. \end{array} \right\}$

Witness my hand this \_\_\_\_\_ day of (month and year).

**MEDICAL PAPER.***Questions.*

1. Is the proposer . . . known to you?
2. Date of your report?
3. Is he without disorder or disease, and sound and without deformity of body or limb? If deformity or disease, what is it?
4. Has he any tendency to asthma, fit, rheumatism, pulmonary, or any scrofulous disorder?
5. Does he appear to be a healthy man of temperate habits?

*Answers.**Medical Certificate.*

I, \_\_\_\_\_, recommend the Postmaster-General to accept the proposal of the above named \_\_\_\_\_, of \_\_\_\_\_  
(Date, and Signature of Medical Examiner.)

The local Postmaster shall take notice of the proposer, and report on his appearance, in accordance with the Form already issued for Government Life Insurance, viz., to answer questions 1, 3, 4, 5, and 6 (which need not be given here), and he shall, in any case in which further inquiry appears requisite, report the result of such inquiry.

I will now show the manner of dispensing sickness-pay. On receiving a notice of illness and medical evidence of the nature of the illness, which the member shall provide, the Postmaster of the district shall, within the week, call and see him, and on being satisfied that the claim is correct, shall pay the weekly amount as soon as the same is due, and he shall take care to see the sick member from week to week, unless the medical certificate renders such visit clearly needless. The medical certificate shall be on a printed form to be supplied to the member, and as follows :—

I, \_\_\_\_\_, hereby certify that \_\_\_\_\_, being a member of the Post-Office Friendly Society, District No. —, is suffering from (ailment to be stated), and is wholly incapacitated from work.

The certificate to be renewed from week to week, unless the illness is of such a kind as obviously to render such a weekly renewal needless; in which case, it shall be renewed at the end of each fortnight.

It may be remarked that medical men readily afford assistance of this kind. In districts where the members are sufficiently numerous, a medical club may be formed at a cost of 4s. to 5s. per member per annum.

#### ENDOWMENTS.

The endowment is an insurance by which a person may secure for himself or nominee a sum not less than 5*l.* nor exceeding 200*l.*, and, for the sake chiefly of others than those of the labouring classes within the range of poor-relief, I should like to see facilities given for obtaining it at the Post-Office, and therefore sub-join the form of proposal for this most useful benefit. It would speedily make its way among artisans, mechanics, and servants, especially women servants who are able to lay by a little from their wages; and it would encourage the latter to spend less on their dress than they oftentimes do, and keep the money for their married life.

#### *Endowment No. 1 (Self).*

I, \_\_\_\_\_, of \_\_\_\_\_, in the county of \_\_\_\_\_, born on the \_\_\_\_\_ day of \_\_\_\_\_, in the year \_\_\_\_\_, by calling or profession a \_\_\_\_\_, do hereby propose to Her Majesty's Postmaster-General to make an Insurance in the Post-Office Friendly Society

for an endowment for the sum of (£) (pounds) to be paid to me  
 on my own account at the end of years, for which I shall have  
 to pay a monthly contribution of

Witness my hand this day of

*Endowment No. 2 (Nominee).*

The foregoing form will, with the following alterations, be available. Instead of "to be paid to me," set—

"For and on account of , born on day of  
 , at ; and to be paid to  $\left\{ \begin{array}{l} \text{him} \\ \text{or} \\ \text{her} \end{array} \right\}$  or on  $\left\{ \begin{array}{l} \text{his} \\ \text{or} \\ \text{her} \end{array} \right\}$   
 account at the end of years, and for which I shall have to pay a  
 monthly contribution of

"Witness my hand this day of ."

"The above named Nominee is  $\left\{ \begin{array}{l} \text{son} \\ \text{or} \\ \text{daughter} \end{array} \right\}$  of , and  
 , his wife, in the County of , and  $\left\{ \begin{array}{l} \text{his} \\ \text{or} \\ \text{her} \end{array} \right\}$   
 father is by calling or occupation a ."

The following rules relating to Endowments are suggested:—

Endowments or prospective provision to any amount from 5*l.* to 200*l.*, may be contributed for, to be paid to contributors or to the nominees of contributors at the end of any number of years, being not less than seven or more than twenty.

An Endowment Insurance may be made by any person on his or her account, or on account of any other person nominated in the policy of insurance to receive the sum insured.

In the case of the death of a nominee for whom and on whose account such insurance shall have been made, and also in the case of the death of any person who shall have made such an insurance, the total amount of monthly contribution, or of any redemption payment which may have been received for the same, will be paid back. In the first named case, it will be paid back to the person who made the insurance; and in the second case, it will be paid and disposed of as burial-money would be paid if the insurer had made such an insurance. Interest will be paid also on such sum at per cent., where the insurance shall have been in existence seven years or upwards.

A Table showing the monthly contributions to be paid for sums from 5*l.* and upwards to 200*l.* may be constructed for this purpose, if the interest is to be calculated at 2½ per cent., the interest allowed on deposits in Savings Banks.

If 3 per cent. is the interest, the following example will suffice:—



£.				Monthly Contributions.	
				s.	d.
For 5	to be due and paid at the end of 7 years, is			..	1 1
" 5	"	"	8	..	0 11½
" 5	"	"	9	..	0 10
" 5	"	"	10	..	0 9
" 5	"	"	14	..	0 6

For 10*l.* the monthly contributions would be double the above, and so on in proportion for any sum up to 200*l.*

A Redemption Table, showing the sum to be paid down at once, instead of monthly contributions, in order to entitle the person paying any of such sums or his or her nominee to secure an endowment of 5*l.* at the end of a stated number of years, need not be given here; nor need a specimen of the Endowment policy be given. The latter will be of two kinds—one for "self," the other for "nominee." The rules relating to fines and forfeitures being the same as those in the case of sickness-pay and burial-money, should be printed on the back of the policy for Endowment insurance.

*Remuneration to Officers for their Services.*

When a Sickness-pay and Burial-money proposal has been accepted and the *second* monthly contribution paid for it, the amount of such second monthly contribution is to be paid to the officer of the district.

For each Old-age-pay insurance the officer shall retain 1*s.*, provided the 6th monthly contribution has been paid thereon. When an Endowment proposal has been accepted and the *second* monthly contribution paid, 3*s.* is to be paid to the officer, if the monthly contribution amounts to or exceeds that sum, and in every other case, the whole of the second monthly contribution.

Annual allowances to be paid to the officers for receiving contributions of members and managing the business of their district as follows:—

At the rate of 4 per cent. per annum upon the full amount of monthly contributions for sickness, burial-money and old-age-pay. At the same rate for endowments, but so that no percentage to the officer for any one endowment shall exceed 3*s.*

The medical fee for passing members for labourers' Benefit Societies is usually a shilling. In some cases half-a-crown is charged, which is paid by the proposer. The same custom of leaving the proposer to pay for the medical certificate should be observed by the Post-Office for the present.

It is necessary to provide for the expenses of the management, for which purpose the following rule will be useful:—

All moneys received by means of legacies, donations, grants,

or from any source whatever, shall be carried to an account to be called "The Management Fund Account," and a percentage, as the Postmaster-General, assisted by an actuary, may judge to be safe and necessary, shall be annually charged upon the amounts of contributions annually received on account of the several branches of insurances. All fines and forfeitures shall be carried to the same account. If on valuation "The Management Fund Account" shows a surplus properly available as bonus, the same shall be applied to members who have chronic illness, and shall be thought best entitled to help.

The Post-Office Friendly Society should not be placed under the supervision of the Registrar of Friendly Societies.

Against the proposal to establish a Post-Office Friendly Society several objections have been urged, which will now be considered. In approaching them I express the wish that the fair treatment shown by the representative of the Foresters, at the Conference of the Friendly Societies Association held last year in London, under the presidency of the Earl Nelson, when the plan was discussed, might be observed by objectors whose scruples are grounded on a fear of Government intrusion into the field of insurance. "If any gentleman," said Mr. Pinchbeck, "proposed to open an opposition shop, the Foresters have no objection." We believe that so far from causing injury to Societies whose business is properly done, the increased attention to insurance which the establishment of this plan would draw from the public would benefit such Societies greatly. Such is the feeling with which the Managers of the County of Kent Friendly Society, who first brought the proposal forward, regard the assistance which the Legislature would thus give, if the system were established and properly worked. The objections of the managers of unsound, or of worse than unsound Societies, or of insurance companies which compete keenly for sums of even small amount, and who view with disfavour Government and Friendly Societies alike when they undertake life insurances—though they are welcome to all the annuities—will not be allowed to carry much weight. They do, however, supply persons who are endeavouring to carry out a reform in the means of insurance among the labouring classes, with a reason for pressing vigorously on the establishment of a system which, while it would help to break up the bad, would encourage good and trustworthy provident institutions.

The Kentish deputation to the Postmaster-General, in 1867, were given to understand that steps would be taken for the reduction of Life Insurance from 20*l.* to 5*l.*, and for the establishment of Endowment Insurance, and that the sickness-pay should receive careful consideration. Nothing whatever has been done

from that time to the present, and a great opportunity of assisting the work of the social and moral improvement of the labouring classes has thus far been neglected. Surely, the consideration that advantages are being withheld from persons who, by their own unassisted intelligence, cannot help themselves, will have weight.

The objection started by some actuaries that sufficient personal supervision cannot be exercised by the Post-Office, and that, therefore, the frauds guarded against in small Societies would be easily practised on the Post-Office Society, is founded in ignorance of the practical working of such supervision, and of the existence of superior means of protection.

The returns of sickness in such Societies in the south-eastern district of England are stated at about 27 per cent. per annum, and are probably higher. In the County of Kent Friendly Society, in which it is impossible to adopt the system of espionage of members over one another, inasmuch as the members are scattered over the county, the returns are very considerably less; the members have, as a rule, but little personal knowledge of each other, and the percentage is seldom as much as 15, and has been under 11. This Society employs the method of supervision recommended for the Post-Office. In the Hampshire Friendly Society, the rate is still less. Both Societies have been established upwards of 40 years, and are solvent; the former is wealthy. Will anyone seriously maintain that the means of protection against fraud and imposition used by these Societies could not be used at least as effectively by the Post-Office? It is in truth a frivolous objection to allege that the latter could not adopt securities against malingerers, of a much better kind than those used in Societies which resort to the questionable protection of espionage. In practice, any fraudulent use of the sickness fund is a dangerous experiment.

Nor are there the opportunities for simulating sickness among labourers which persons who know but little of them may suppose. When by the terms of their insurance there must be compulsory idleness; no drinking with boon companions in the beershop, or being so much as seen within its proscribed precincts; but a home with little or no comfort for the pseudo invalid, and probably much discomfort—the position becomes untenable, and outdoor work on a winter's day is preferred.

Putting aside the common honesty and fair dealing of labourers, the reader will have observed that testimony as to character is required in the questions for proposers for sickness-pay and burial-money. Labourers prefer 14s. a week at their work to 12s. claimed under compulsory confinement to the house, received at great risk, and under much discomfort.

Another objection is that, conceding the feasibility of the plan, its adoption would cause a great addition to the duties of the district officials. We can only reply that the latter are found gladly to undertake work of the kind, provided *that they are fairly paid for doing it*. They make very good agents of Friendly Societies, and the work is not by any means heavy. In a district of 100 members, which would be a large district, the number of the sick, according to the returns from Societies in which the espionage of the members over each other is resorted to, would be 27 per annum. But with the system advocated in this article, it ought not to exceed 15 in the course of the year, or thereabouts. And the payment of their claims, as well as the receipt of the contributions of all the insured, is no considerable addition to the duties of a district post-master.

Another objection arises from the persuasion that collectors are required to call on the members week by week for their contributions, in reference to which practice I venture to remark that it will be strange indeed if the evidence elicited by the Royal Commission does not point strongly to the conclusion that the custom of employing collectors is not for the benefit of the members but for that of the collectors. Their books have a considerable marketable value, and hence the enormous percentages charged for collection. These charges are defended as necessary. Necessary, we ask, for whom? Certainly not for the due care of the members who pay them. Once let members clearly understand that arrears of contributions place their benefits in jeopardy, and entail fine and forfeiture which will be duly enforced, and they will be very careful how they get into arrear. They will come to the district office and pay readily enough. A system which showed to persons insured in Societies where enormous charges for collection are levied that such expenses might be saved and collectors be dispensed with, would be a great boon to many deserving poor. The answer to this objection, as in that relating to the supervision of sick members, is one the weight of which tells heavily against the opponents of the scheme.

The last objection requiring notice is that since insurances have been obtainable at the Post-Office the public have shown a declining interest in them, and it is asked whether the same apathy would not be manifested in the event of sickness-pay and burial-money and endowment insurances. To such a supposition—and it is no more—we reply that it would be strange indeed if the attempts at providing insurances through the Post-Office had secured much attention: the Life Insurance is, even as compared with the limit imposed on Friendly Societies,

greatly restricted; the sums are limited to amounts not exceeding 100*l.*, and not less than 20*l.*; and, with regard to the Annuities, the public require time before they will understand their right use. Much improvement is also required in the manner in which these insurances are brought before the labouring classes. At present the people are mostly puzzled and discouraged by the lengthy papers and the process of securing insurances; and as the officials are not paid sufficiently to make it worth their while to attend to the work, little or nothing is done. All this might, and we trust will, be set right, and we may then reasonably anticipate that a fair share of business, even in the annuities, will be obtained.

I have now noticed the principal objections started against the Post-Office plan, both by persons who are desirous to keep the Government out of the field of insurance, and by those who are giving thoughtful attention to the proposal, with the desire to see some means devised and employed by which the helpless condition of the wage-paid labourers of the lower class in respect of insurance may be improved, and who desire to have such objections discussed with a view to test the importance to be attached to them. I trust that it has been shown that the importance of such objections has been over-estimated, and that there is no sound and insurmountable difficulty in the way of this part of the method of improving the condition of labourers.

In a paper\* advocating "Sickness-pay through the Post-Office," by the Hon. Edward Stanhope, formerly Assistant-Commissioner on the employment of children, young persons, and women in agriculture, the advantages of the plan are thus summarised:—

(1). The security of the insurance will be indisputable, and will not be affected by anything short of a great national convulsion.

(2). It will give to all insurers the advantage of transferring their place of abode without interfering with their insurance.

(3). It will give facilities for greater economy of administration, and

(4). Afford a standard of economy and good management to other Friendly Societies.

Something has been said of the desirability of the Annual Festival. Against this institution I have nothing to object, so long as it is managed with order and decorum by the members themselves. A district of the Post-Office Friendly Society might have its annual festival, either separately or in conjunction

---

\* Read at the Conference of the Friendly Societies Association in London in 1870.

with other districts, for which purpose the members would raise the necessary expenses.

I have elsewhere pointed out that, with this system of insurance, and with trustworthy Societies, there could be no hesitation on the part of local trustees of charitable funds in assisting members at times of unusual pressure in paying their monthly contributions. The difficulty of dispensing charity in such a manner as not to discourage thrift would thus be obviated. Such is the state of existing Benefit Societies that I do not suppose any trustee could venture to help a man, although, from the pressure of illness, or the number of little ones in his family too young to earn anything towards their maintenance, such assistance would be extremely well bestowed if only his club were trustworthy. I am painfully reminded of the want of some such means of applying parish charities, which are yearly distributed at Christmas in my parish, and to the thorough dissatisfaction both of trustees and recipients. It would be a great assistance to a few deserving men in the parish to give them 5s. each towards their club payments; but the clubs are unsafe, and the money goes to some persons whose earnings, take one year with another, are as large as the livings of many of the "mountain" clergy in England, or their brethren in the Principality. The recipients will all of them, I fear, sooner or later, be paupers, if they are not already.

While the Post-Office Friendly Society would give to the country one provident institution which the Guardians of the poor would admit as favourable to the claims of a member belonging to it, it would also attract to itself the influences which are too often kindly but injudiciously given by the clergy, the gentry, and others in behalf of unsafe and pauperising clubs. Many steady young men would, by their influence, join it, and their example would tell on their companions. Those persons whose infirmities debarred their joining it, are among the class for whom the Poor Law is, and always will be, required in this country. And persons whose age may prevent their joining will be better off than they are at present in respect of Benefit Societies, many of which, with the example and influence of a district Post-Office branch among them, would be improved both in constitution and management. The members of these Societies would then experience the benefits of being in institutions which possessed genuine claims to trustworthiness and providence, and thus their own comfort and well-doing would be promoted.

The method by which these advantages may be placed within reach of many labourers who are at present within the verge of poor-relief has, with many imperfections and shortcomings

on my part, been now discussed. It is briefly comprised in (1) deterrent measures from resort to the rate, together with (2) a system of insurance suited to persons diverted from such resort, under Government supervision and by means of the Post-Office. By applying it to the labouring classes, waste and improvidence will be greatly repressed, and habits of thrift, by which they may attain an independence suited to their lot in life, encouraged and confirmed, and their comfort and well-doing be thereby increased and established.

NOTE.—In the foregoing method no change, either in the administration of the Poor Law as regards relief, or provision for sickness-pay and burial-money, is contemplated for females. Women would be eligible at the Post-Office for life insurance, as they are now, for burial-money without sickness-pay, for annuities, and for endowments.

---

III.—*The American Milk-Condensing Factories and Condensed Milk Manufacture.* By X. A. WILLARD, A.M., of Herkimer, New York. Lecturer in Cornell University and in the Maine State Agricultural College; President of the New York State Dairymen's Association and Board of Trade, &c., &c.

THE history of experiments for condensing milk in America dates back to 1846. Possibly the idea of reducing milk to a solid may have occurred earlier in Europe, but if experiments were made they were not successful, or at least were of no practical importance. Preparations under the names of "Desiccated Milk," "Milk Powders," and "Milk Essence," have been in the market for many years, but they were all too imperfect to meet the conditions required for general introduction. They were articles prepared from milk, and not the actual milk itself.

It became evident at an early stage of the experiments that if milk could be divested of its water, leaving the other constituents uninjured and unaltered—in other words, if milk could be converted into a solid, so as to be easily kept for long periods, and then by the addition of water could be brought back again to its original consistency and flavour, such a form of milk would prove a boon to consumers, and must find a ready sale if put upon the market at reasonable prices. To Mr. Gail Borden, of White Plains, New York, must be awarded the credit of essentially accomplishing these results. It is true that by his process the milk is not reduced to a solid or dry state, but three-quarters of its bulk in water are removed, while the other conditions are

very perfectly met ; and in this form it is better adapted to the manifold uses and wants of consumers than if it were in a dry state. The history of Mr. Borden's labours and ultimate success has been well portrayed in the 'Milk Journal,' which it may not be out of place to quote, at the same time correcting some errors therein stated.

It is affirmed that "all the brands of good or even fair quality now sold, are prepared substantially under the system originated by him (Borden). A man of intense energy and unyielding tenacity of purpose, and an inventor of great ingenuity, if not of remarkable scientific attainments ; he added to all this the enthusiasm of the philanthropist, who believed that preserved milk would be a boon to humanity. As long ago as 1849 he began his experiments, conducted simultaneously with others, whose aim was the preservation of meat."

It may be mentioned here that, at the London Exhibition of 1851, a Council bronze medal was awarded to Mr. Borden for his meat biscuit. We believe he did not at that time exhibit his condensed milk. It was not until about 1853 that he himself arrived at the conviction that he had obtained the quality he had been seeking. Meanwhile he had expended energy, time, and quite a fortune in his experiments ; for he at length saw that to experiment to advantage, a large amount of material, involving much expense, must be used in each instance.

At an early stage of his experiments he decided that milk could not be preserved in a dry form as "desiccated," or "powdered," or solidified, but must be left in a semi-liquid state. That some preservative agent must be added, and that nothing but water must be removed, also became apparent. The result is that condensed milk, as now known to the trade and consumers, consists of milk from which only water has been taken and to which nothing but sugar has been added. The product is of the consistency of honey, and, by dilution with water, it is easily reconverted to milk itself somewhat sweetened. It may be here stated, that all the dry preserved milks require to be dissolved in hot water, while the condensed milk prepared under the Borden system readily dissolves in cold water.

By 1861 Mr. Borden had extensively introduced his preparation, and four or five factories were in operation, capable of producing in the aggregate 5000 1-lb. cases per day. During the War of the Rebellion, large quantities were required for the Northern armies, the officers and many privates purchasing it of the sutlers, while the hospitals were supplied by the Government, and the various Christian and Aid Societies. This gave an impetus to the trade, at the same time that the shipping demand steadily increased.



About 1857 Mr. Borden put into the market, for city use, what he called "Plain Condensed Milk." This is prepared in the same way as the other, except that no sugar is added, and it is not hermetically sealed. It will remain sound from one to two weeks, according to the temperature in which it is kept, and it is so convenient as well as economical, that it is stated that a large quantity of the milk used in New York city is of this kind. With the end of the war, and the dissolution of the armies, the demand for sugared condensed milk fell off; and the manufacturers, who had been stimulated to too great a production, turned their attention to this "Plain Condensed Milk."

I have no means of estimating the present extent of the manufacture of condensed milk in the United States. For this one must wait for the returns of the census of 1870. However, it is known that the capacity of the eight or ten factories on the Hudson, in Connecticut, Pennsylvania, and Illinois, is not less than 500 cases of four dozen 1-lb. cans per day—equal to eight million five hundred thousand lbs. per annum. It may be stated that 1 lb. of the condensed milk is equivalent to 3 or 4 lbs. of the crude milk.

In 1865, an American gentleman who had noted the advantages of condensed milk in the American army during the few years of the war, became resident in Switzerland in the capacity of United States' consul. Remembering the cheapness and richness of Swiss milk, the cheapness of labour, and other facilities afforded in that country, he conceived the idea of preparing condensed milk in Switzerland. He communicated his views to a gentleman late of the United States Patent Office, who visited several factories in America producing the condensed milk under the Borden process, where he learned the art of manufacturing the milk by this process, and commenced manufacturing the same in Switzerland. The ultimate success of his project has abundantly proved the soundness of his conception. He promoted the Anglo-Swiss Condensed Milk Company, the extent of whose present business is set forth in the following extract from the 'Grocer' of December 31st, 1870. The facts seem to have been compiled from statistics preserved at the Board of Trade, which were doubtless obtained from the Report of the British Legation at Berne:—

"In the canton of Zug there has lately grown up a new mode of preserving milk, which, owing to the good pasturage of that locality, is very excellent in quality. In the commune of Cham the Anglo-Swiss Condensed Milk Company, with a capital of 12,000*l.*, employ about sixty operatives in their factory, the tall chimney of which may be seen by the railway traveller passing over the line from Lucerne to Zurich. The number of cows

hired for the year is 1440, and the average amount of condensed milk prepared daily during the 365 days of the year, as it is necessary to include the Sundays, is 110 cases, of four dozen each of 1-lb. cans; these equal 1,927,200 cans as the product of the year. The price of the crude milk is 17 c. per maas, or about 2d. per quart; and the daily cost of the tins or cans made at this establishment amounts to 16l. 10s. About one half of the product is sent direct to London, where one half of this is consumed, while the remainder goes for ships' stores, is exported to the colonies, and sent to the provincial towns of England."

"The half of the produce not sent to London is distributed over Germany, and there is some demand from France and Russia."

\* \* \* \*

It should be mentioned that this Company was the first in Europe to introduce condensed milk to family use. Until its advent the article was known only for ships' stores and for colonial consumption. By extensive and systematic advertising, and through the boundless energy which characterises your business Yankee, this Company has received a large demand for ordinary family consumption, not only in England but also in Germany and Russia. In this respect its success may be largely attributed to the fact that Baron Liebig and other authorities on questions of food supported it heartily from the first, and allowed the patronage of their names for publication. Its success led, naturally enough, to the springing up of competitive companies. These have been established at Gruyères and half-a-dozen other places in Switzerland, in Bavaria, in Holstein, in Ireland, and in England; but, failing to produce a standard quality, and wanting in *prestige*, they have nearly all ceased to manufacture. All now known to the London trade are the "Anglo Swiss;" Mr. Newman's "Irish Condensed Milk," at Mallow, near Cork; and the "English Condensed Milk Company," whose works are at Aylesbury, Buckinghamshire. The two last put their milk in the market during the year 1870, and it is stated upon good authority that neither the Swiss nor the English Company has lately been able to supply the call for their products.

In Mr. Borden's early experiments, and indeed up to within a few years past, the nature and cause of a peculiarly bad behaviour of milk, from time to time, were imperfectly understood. Under certain circumstances and conditions the milk could be readily handled, and gave no trouble in its manipulation. When in this state, comparatively inexperienced operators—men who simply followed a set of rules, with little or no knowledge of principles—were enabled to turn out a good product, whether

it was condensed milk, or butter, or cheese. Sometimes these conditions would continue for days, for weeks, and for months; but there was no reliability on its continuing for a specified time, or, indeed, in different localities during the same time. The milk might be easily worked on one day, and on the next would refuse to be controlled under ordinary treatment. The fault at first was supposed to originate in some want of cleanliness, either at the factory or among those who produced and delivered the milk. This was a part, but not the whole of the trouble. The importance of cleanliness, and of what seemed to many to be "an absurd fastidious neatness," became apparent to Mr. Borden at an early stage of his investigations. He therefore instituted a set of rules for the government of dairymen in the care and management of milk; and as he bought only such milk as would pass the closest scrutiny of an expert, he was able, after a time, to enforce an observance of his printed regulations among dairymen. I shall presently refer to these rules and give them in detail, because they strike home to some of the leading principles for obtaining good milk, and they are such as should guide dairymen generally. He adopted also the practice of cleaning and steaming his patrons' delivery milk-cans at the factory, because he feared—and with good reason too—that this work might not be properly done at the farm. But when farmers had become educated, and all his conditions of cleanliness had been observed and carried out to the letter, milk not unfrequently came to his factories, which—though apparently perfect, or at least so perfect as to pass the rigid scrutiny of his experts—was in a condition that rendered it impossible for it to be converted into a good product. The reason for this was not of easy solution, and it has been the cause of heavy losses and of the closing up of factories which were not under the immediate supervision of Mr. Borden.

It may be observed here that good condensed milk is without doubt more reliably clean and healthy than most milk that goes to the city consumer. Dirty milk—milk foul with the drippings of the stable—cannot be condensed into a clean-flavoured product. The success of the condensing factory depends entirely upon the ability to put a fine-flavoured, perfect article into the market. The milk must be uniformly good. An inferior condensed milk is more readily detected than an inferior article of cheese. At least, imperfections in cheese may be tolerated, and the article may find a place in the market; but a factory continuing to send out imperfect or badly flavoured milk must soon cease to be remunerative, and must inevitably close its doors. To obtain any success in this business there is an absolute necessity for clean healthy milk in the first instance; and when a knowledge of this

fact becomes familiar among consumers, condensed milk must take the place of the vile fluid bearing the name of milk which now is hawked about in all leading towns and cities.

It may be well to warn those who propose to enter upon condensed milk manufacture, that more than ordinary difficulties lie before them. In the first place, arrangements must be perfected for obtaining good, clean, healthy milk, and this imposes a sort of education upon those producing milk (of the greatest importance), which, at least in the United States, does not generally obtain. This may be properly discussed under the head of the Fungi Theory.

*The Fungi Theory.*—I have said that farmers need to be educated in the production of milk—to be so well grounded in knowledge of facts and principles that a high moral responsibility shall result. I have no Utopian theories for regenerating the world, and I have no hope but that there will always be more or fewer bad men, even among dairymen; but I have faith that most farmers, when they know a thing to be morally wrong, and when they are convinced that right pays best, will generally choose the latter. I assume that no fair-minded man will go deliberately to work administering poison to his domestic animals to make their meat bad and unwholesome, when there is no reason to hope that such meat will sell in the market for more than sound meat, while there is probability that it may sell for less, or may be a total loss. At the same time there is the fear of detection and of being held in the estimation of his neighbours and the community as a knave and a cheat. Why, then, should farmers who have the means at hand for making good milk persist in making that which is bad and unwholesome, if it be not from a lack of knowledge in regard to principles? It is not sufficient to be told that he is making bad milk—the reasons must be given plainly, and the conviction firmly established in his mind as to the truth of the principles enunciated. Then, with this conviction before him by day and by night, his moral sense is brought into action, and permanent improvement may be expected.

The investigations of Hallier and Pasteur with the microscope have explained the nature of causes in operation, which change milk from its normal condition, or which render it filthy and unwholesome. They show that this state is brought about by living organisms, that these pervade the atmosphere, and that the germs absorbed in the milk from this source multiply and increase with wonderful rapidity and take complete possession of the fluid, changing it into their own nature. The germs from cesspools, from decomposing and putrid animal matter, when introduced into milk, carry their own peculiar taint, and by

their growth and multiplication soon convert the milk into a filthy, putrefactive mass, similar to that of the substance from which they emanated.

"The *Micrococcus*, for instance," says Professor Caldwell, "appears only in substances rich in nitrogen, but when it does appear, no matter from what fungus it may come, it causes putrefaction; the *Cryptococcus* not only causes the particular kind of decomposition called alcoholic fermentation, but appears only in solutions that are fit for that kind of decomposition, and so on."

The wonderful rapidity with which these fungi produce new cells, each of which can act as a starting-point for new and distinct growth, also increases their power of making their influence for good or evil to be felt everywhere.

"The *Penicillium crustaceum* can run through its whole course in 48 hours at the most, at a temperature of 50° to 60° Fahrenheit, and produce a new crop of several hundred spores for each old one; and in 48 hours more each spore of this crop of several hundred will produce several hundred more, and so on. At such a rate of multiplication, it would take but a few days to reach numbers too great for an adequate conception. And what is more, this is not the only way, nor even the most rapid way, in which the *Penicillium* can propagate itself; a *Penicillium* spore will in the course of an hour, at a moderately elevated temperature, produce from 20 to 100 *Micrococcus* cells; each one of these cells will subdivide into two in another hour, and so on. At this rate of increase, we should have, at a low estimate, of 50 cells from one spore, to start with, four hundred million *Micrococcus* cells from this one spore in 24 hours." Again he says, "From the moment the milk leaves the cow the work of the fungi commences; they begin to increase, and simultaneously the milk begins to change—both operations going on with a rapidity that varies according to the circumstances of temperature and exposure, and never ceasing entirely till the milk or its products are digested in the stomach, or have putrefied or decayed in the air, producing results that vary according to the product, whether butter or cheese, or simply the milk itself; and what is very important and more pertinent to my subject, according to the kind of fungus that gets a foothold in the substance. The elements of fungi that are already in pure clean milk, to begin with, or that are added in the rennet (when cheese is made), appear to do no harm; but, on the contrary, by their legitimate growth and action on the substance in the midst of which they find themselves, to bear at least an important part in the elaboration of the very principles which give the final product its savour and its value. But the case is quite different

with such fungi as are introduced from without and which originate in *putrid matter* of any kind; their whole influence is harmful in a high degree. It is one of the most commonly observed facts of nature that milk is especially susceptible to the influence of emanations from putrid matter; or is liable to become tainted, *as it is more generally put*; which are but other ways of saying that the germs of fungi that are continually thrown off from putrefying matter find in the milk a place where they can readily grow and multiply; and so insidious are these influences, so readily can these minute germs make their way anywhere and everywhere, that if the air containing them in unusual quantity is *inhaled by the cows, the milk will be infected before it leaves the bag.*

This statement is consistent with numerous well authenticated facts. Milk from cows inhaling bad odours has been found to be tainted and incapable of being made into good cheese. The fact was first brought to notice by Mr. Foster, of Oneida, whose herd of cows inhaling the emanations from the decaying remains of a dead horse, caused their milk to be unfit for making cheese—and not only the milk of the cows which inhaled the odour, but that from a large number of other cows, which had been mingled with the former in the cheese-factory vats. All the facts concerning the case were so carefully noticed and investigated, that it left no doubt as to the cause of the tainting of the milk. Repeated observations of a similar character, by members of the American Dairymen's Association, established the principle beyond doubt. Milk producers, then, may regard this point as a settled principle;—they cannot allow their cows to inhale offensive emanations from putrefying animal matter without injury to their milk; they inoculate the milk with the germs of filthy fungi, which make haste to convert it into filth, similar in character to that of the putrefying substance from which they emanated. To what extent the health of stock, and that of persons partaking of such milk, may be affected by such organisms, is a question of great importance, but concerning which I have not sufficient data to venture an opinion.

Again, I have seen numerous cases where milk was tainted from the cows having passed through sloughs of decomposing vegetable matter. Particles of dirt adhere to the udder or other parts of the animal, and, becoming dry, some of the dust perchance falling into the milk during the milking, thus introduce germs which make rapid work in decomposing and putrefying good healthy milk.

A most notable example of this came under my observation while on a visit to the cheese factory of Mr. L. B. Arnold of Tompkins county, in 1870. When the milk was received at

the factory, there was no reason to suspect taint from any particular dairy. The deliveries from the several patrons went into the vat together, and were set in the usual manner with rennet. But, during the process of heating up the curds, a most intensely foul and disagreeable odour was emitted. The cheese-maker sent for Mr. Arnold and myself, and we went to the factory together. We found the curds, then about half scalded, giving off a stench exceedingly offensive—a smell like that coming from a nasty mud hole, stirred up and exposed to the air in hot weather. There was no mistaking the peculiar odour, and I suggested at once that some of the patrons were allowing their cows to slake their thirst from stagnant, filthy pools. He afterwards traced the milk to its source, and found the trouble to come from one patron, who allowed his cows to cross a narrow slough, where particles of mud adhered to the udder. These became dry, and the dust entered the milk during the milking, and introduced a class of fungi which, by multiplication, spoiled the milk. The patron had meant no harm. He had taken every precaution, so far as his knowledge extended, for the delivery of good milk, and on correcting this fault the trouble ceased.

Another case in point occurred during the past summer, 1871. Professor Law, of Cornell University, gets his supply of milk from a "milkman." One day, during the hot weather, he observed a peculiar ropy appearance in the cream which had risen on the milk. He examined it under a powerful microscope, and found it filled with living organisms of a character quite foreign to good milk. He immediately called upon his milkman, to enquire concerning his management of stock, and general treatment of milk, with a view of accounting for the trouble. There was no fault discovered at the dairy-house, in the milking, or in the treatment of the milk; but on looking through the pastures, he found that the cows, for lack of clean running water, were compelled to slake their thirst for the most part from a stagnant pool. This water he examined under the microscope, and discovered the same class of organisms as those in the cream. He then took some of the blood from the cows and examined it under the glass, when the same organisms made their appearance. He next obtained a specimen of good milk—milk which on examination was free from impurities, and into this he put a drop of water from the stagnant pool. In a short space of time the milk developed an infinite number of these living organisms, and became similar in character to the milk obtained from his milkman. He examined the cows, and made the usual thermometer tests for determining health and disease in animals. The cows were found to be hot and feverish, thus evidently showing that these organisms, entering the circulation, had affected the health of the animals.

I have called attention to these facts because it has been very commonly supposed among milk producers that so long as a due degree of cleanliness in respect to dairy utensils has been observed, the responsibility of bad milk can be shifted upon other persons. I have said that it is important that the milk-producer who delivers milk to the condensed-milk factory be thoroughly educated in all the leading causes which injure milk—that he have a moral sense of the dishonesty and wrong he would be doing in delivering milk which he has good reason to believe would spoil the whole product of the factory for the day. No system of inspecting the milk, as it comes to the factory, will reach all the causes affecting milk, or determine imperfections often contained in it at the time of delivery. The milk of cows in heat, or of cows over-exercised, on account of this disturbance, cannot be used with safety. Yet when such milk comes to the factory, mingled with the other milk from the herd, it will be very likely to pass the scrutiny of the expert and to be accepted. Under the best management and most careful examination, losses will inevitably occur from time to time on account of imperfect milk, and a certain percentage must be allowed in making up an estimate of expenses to cover this item. But unless there be some reliability for obtaining good, clean, healthy milk, it would not be advisable to enter upon condensed milk manufacture. To this end the character of the country where the milk is produced should be studied.

The pastures should be upon high undulating or well drained soils, the farms should have an abundance of clean, sweet, running water, while extra attention should be given to the care and management of herds, never over-driving in hot weather, milking with regularity and with fastidious neatness, together with absolute cleanliness in dairy utensils and dairy buildings.

I am told that Mr. Borden's success has resulted in a great measure from placing his factories in the most favourable districts for obtaining good milk. In every instance he selected for his milk producers, persons whose long experience in furnishing milk for city consumption had taught a higher appreciation in the care of milk than is common among the cheese dairymen.

Upon this element he commenced, and drew up a set of rules for guidance in the delivery of milk, a faithful performance of which was rigidly exacted. These rules are as follow :—

*Borden's Rules for the Treatment and Delivery of Milk.*

I. The milk shall be drawn from the cow in the most cleanly manner, and strained through wire-cloth strainers.

II. The milk must be thoroughly cooled immediately after it is drawn from



the cow, by placing the can in which it is contained in a tub or a vat of cold water, deep enough to come up to the height of the milk in the can containing it, and at least three times as much water as the milk to be cooled; the milk to be occasionally stirred until the animal heat is expelled as below.

III. In summer, or in spring and fall, when the weather is warm, the bath shall be spring water, not over  $52^{\circ}$  temperature (a day or a night after a heavy rain excepted) constantly running or pouring in at the bottom, necessary to reduce the temperature of the milk within forty-five minutes to below  $58^{\circ}$ , and if night's milk, to remain in such bath until the time of bringing it to the factory to below  $55^{\circ}$ . The morning's milk not to exceed  $60^{\circ}$  when brought to the factory.

IV. In winter or in freezing weather, the bath shall be kept at the coolest point (it need not be running spring water) by the addition of ice or snow sufficient to reduce the temperature of night's milk speedily below  $50^{\circ}$ .

V. In spring and fall weather a medium course will be pursued, so that the night's milk shall be cooled within an hour below  $50^{\circ}$ , and morning's milk below  $55^{\circ}$ .

VI. The bath and supply of water shall be so arranged as to let the water flow over the top, to carry off the warm water. The can in which the milk is cooled shall be placed in the water immediately after the milking, and shall remain therein until the process of cooling shall be finished.

VII. The night's and morning's milk shall be separately cooled before mixing.

VIII. No milk shall be kept over to deliver at a subsequent time.

IX. The milk shall be delivered on the platform at the factory every day except Sunday.

X. Suitable cans of proper dimensions to transport the milk from the dairy to the milk works shall be furnished by the seller, and the cans shall be brought full.

XI. The Company shall clean and steam the cans at the factory free of charge, but customers shall keep the outsides clean. The pails and strainers employed shall be by the seller thoroughly cleaned, scalded in boiling water, and dried morning and night.

XII. Immediately before the milk is placed in the cans they shall be thoroughly rinsed with clean cold water, and great care shall be taken to keep the cans and milk free from dirt or impurities of any kind. When the cans are not in use they shall be turned down on a rack with the tops off.

XIII. All the "strippings" as well as the first part of the milk shall be brought. No milk will be received from a cow which has not calved at least twelve days, unless by consent of the superintendent or agent, who may determine its fitness sooner by a sample of the milk.

XIV. The cows are not to be fed on turnips or other food which would impart a disagreeable flavour to the milk, nor upon any food which will not produce milk of standard richness.

XV. It is further understood and agreed by the parties hereto, that if the superintendent or agent of the Company shall have good reason to suspect, either from evidence furnished, or from the state of the milk itself, that water has been added, or that it has not been cooled as provided, or that it has been injured by carelessness, he shall have a right to refuse to receive such milk, or any further quantity of milk, from the person so violating these directions and stipulations.

*Expelling the Vapour by Means of Fans.*—Mr. Borden's plan of condensing milk is to abstract the water *in vacuo*, and a description of his process will be given further on. It involves the

employment of machinery somewhat expensive and complicated, and efforts have been made from time to time to accomplish the object by more simple methods and at less cost. Among the most successful methods brought to my notice was that adopted by Provost, of Orange County, New York.

During the War of the Rebellion there was a large demand for condensed and preserved milks, and the products of the Provost factory met with ready sale. During the year 1865 I visited this factory, and made drawings of its ground-plan, as shown in Fig. 1. The establishment was then under the management of Dr. C. E. Crane, a very intelligent gentleman, who went over the premises with me and explained the various appliances and machinery in use for manufacturing the milk. The process of evaporation was different from that of Borden, and was stated to be less expensive, and to be effected with less heat.

In this plan the engine-and-boiler room is lower than the floor of the evaporating room, and the steam-pipes leading to the heating-vat and condensing pan are carried along in the basement under the evaporating room,

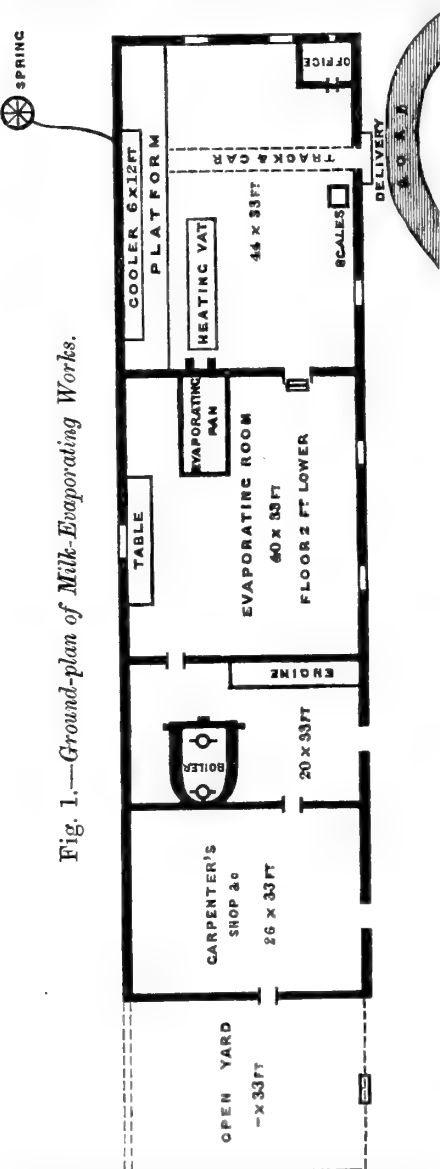

Fig. 1.—Ground-plan of Milk-Evaporating Works.

and are not represented in the engraving. Above the evaporating pan is a chimney-like ventilator, rising above the building, in

which are placed the revolving fans, driven by power supplied from the engine. The leading features in the treatment of the milk are briefly as follows:—The milk, as it comes to the factory, is carefully examined, and, if all right, it is received and weighed. The cans are then placed upon the car, which runs on rails to the cooling-vat. Here the milk is drawn into long tin pails, 8 inches in diameter and 18 inches long, holding twenty quarts each. About eighteen quarts are put in each pail, which is then placed in the vat containing cold spring water. After the milk has been cooled to 60°, the pails are immediately plunged into the water of the heating-vat, which has a temperature of from 185° to 190° Fahr.

The best refined white sugar is then added, at the rate of four pounds for each pail. The pails are kept in the vat of heated water about thirty minutes, when the milk is drawn into the large condensing pan. This pan has fifty corrugations, and is set over water and upon a furnace in the adjoining room. Directly over the pan are arranged the two large fans previously alluded to, which are kept in motion by machinery. The temperature of the milk while evaporation is going on is uniform at 160° Fahr.

The fans carry off the water, forcing it through ventilators, out of the building as fast as it is formed into vapour. Under this process it takes about seven hours to condense the milk, seventy-five per cent. of its original bulk in water being driven off.

The faucets at each end of the pan are then opened, and the condensed fluid passes through fine wire-strainers or sieves into large cans. These cans, when filled, are rolled away to the tables at the back of the room, where their contents are drawn off into small tin cans, holding one pound each, and then are immediately sealed up to exclude the air.

The condensed milk has the consistence of thick syrup, and has a rich creamy taste, rather sweet, with a flavour of boiled milk, but by no means unpleasant. Dr. Crane informed me that milk thus prepared has been preserved in good order for years. He opened cans in my presence containing milk a year old, and it was apparently sound, and of good flavour.

For shipping, this establishment packed its cans in barrels, with sawdust between the packages, a form which insured their safe arrival in market. During the war these pound-packages were sold at the rate of 40 cents each, and the price paid for the crude milk at the factory during summer was about 5 cents per quart, but in winter the price ranged from 7 cents to 7½ cents per quart.

At this factory, like those under the Borden process, two kinds of condensed milk were manufactured—that which has

been described, and the plain condensed milk, in which no sugar is added in the manufacture.

The factory is not now in operation. Whether this plan can be made successful in furnishing a uniform product equal to that under the Borden method is a question upon which I have not sufficient information to give an opinion. The plan has been presented here more for the purpose of showing a different method of condensing than that employed by Borden, and as a suggestion to inventors in the way of cheapening the machinery to be used in this business.

*Cost of Fitting-up a Factory on the Borden Method.*—It is charged as a prominent characteristic of Americans that among the first questions they ask concerning any particular object is its cost. Perhaps this may not always be in good taste, but among practical men, who are investigating a business with the view of investing capital and taking risks, it is always well to look expenses fairly in the face. I shall take up this branch of the subject now, because it can be discussed very properly with the plan of a condensing factory, in which the position of the machinery, &c., is illustrated, and because a general survey of a plan showing the rooms and their appliances would seem to be more in natural order for a clear comprehension of the subject than to separate the parts from the whole and describe each by itself. Fig. 2, on the next page, is a plan of the different departments, showing the machinery required for the condensing operations.

The building is 16 × 50 feet, with verandah or shed 4 feet wide on two sides. The ground-floor is divided into four departments. The first, to the right, is the can-washing room, 16 × 16 feet, containing the hot-water washing-tank, with coil of steam-pipe; the hot-water sink and scalding jacket, and the cold-water sink and platform for cleaning cans. The steam-pipe leads from the boiler to this room. The next is the receiving, condensing, and delivery room, 16 × 16 feet; it contains the receiving and cooling tank, the heating vat, and the vacuum-pan. Then comes the engine-room, 7 × 16 feet, containing duplex engine and pump, the condenser and pump, with steam-pipes leading to the other rooms. The rooms to the left are the coal-shed and boiler-room, 9 ft. 6 in. × 11 feet, where the boiler (60 horse-power) and the boiler-pump are situated. Communication is easy from one department to the other by wide doors, and the whole is arranged for convenience in doing the necessary work.

Now the cost of this establishment is put by Professor Chace, of Cornell University, who obtained the estimates for persons proposing to build, as follows:—

Fig. 2.—Ground-Plan of Milk-Condensing Factory.

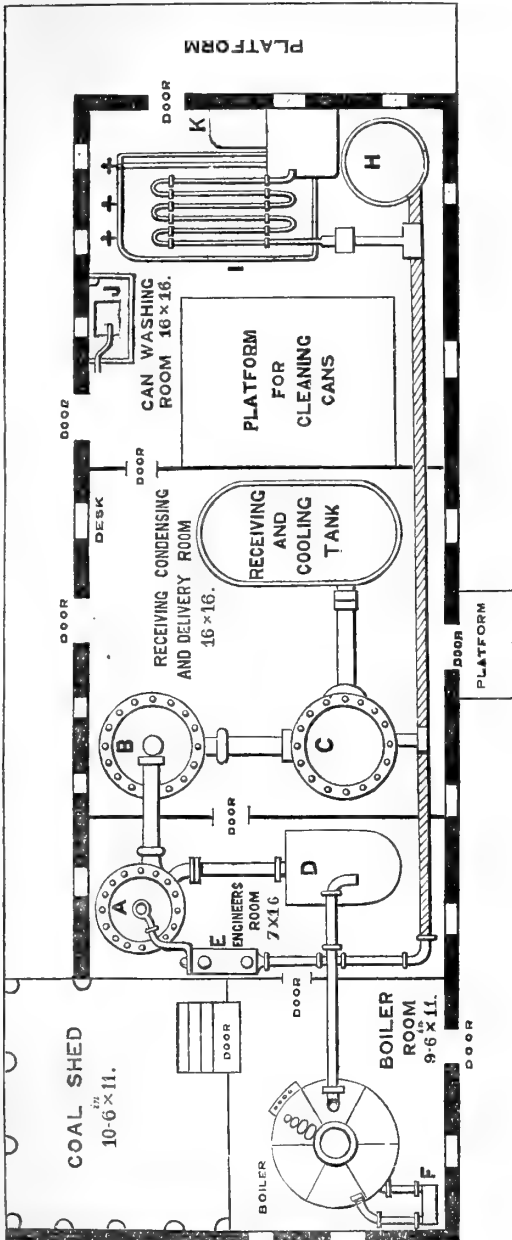

- F. Boiler Pump.
- H. Steam-scalding Jacket.
- I. Hot-water Washing-tank.
- J. Sink.
- K. Sink.

- A. Condenser.
- B. Vacuum Pan.
- C. Heating Vat.
- D. Duplex Engine & d Pump.
- E. E. Pump.

	dollars.
Erection of the building, 16 feet by 50 feet, ready for machinery, &c. . . . .	2500
Vacuum-pan and condenser, from 3 feet to 4 feet in diameter	1800
1 duplex 14-inch pump and engine .. .. .	1500
Piping and fitting out .. .. .	1500
1 boiler 60-horse power and fitting up .. .. .	3000
1 pump for boiler .. .. .	100
Outside water-pipes, not estimated .. .. .	
Water-pipes, &c. .. .. .	500
One cooling-tank for receiving and storage .. .. .	500
One heating-tank and pipes for milk .. .. .	300
Hot-water tank and steam-pipes for washing cans, and two rinsing sinks .. .. .	600
1 steam-bath for scalding cans and pipes .. .. .	150
Total.. .. .	12,450*

The daily working expenses of this establishment may be estimated as follows:—

	dollars.	cents.
5000 gallons of crude milk, say at 12½ cents per gallon	625	
1 superintendent, per day .. .. .	5	
2 men at 2 dollars per day .. .. .	4	
1 engineer .. .. .	2	
½ ton coal .. .. .	3	
Wear and tear .. .. .	2	
Taxes and insurance .. .. .		50
Interest on capital .. .. .	3	
Incidental daily expenses, say .. .. .	5	
Total daily expenses .. .. .	649	50†

To this may be added the value of, say, 200 gallons of crude milk, as an offset against waste, occasional bad milk, &c.

Taking out the 200 gallons of crude milk per day as waste, we have remaining 4800 gallons of milk, which is condensed at a total cost (counting the original value of the 5000 gallons) at the rate of only a fraction above 13½ cents per gallon, or say 1 cent (one halfpenny) per gallon more than the original cost of the milk. This would be at the rate of ¼ cent per quart for condensing.‡

On 2080 gallons—80 gallons being allowed as daily waste—

\* Taking the dollar to be worth 4s., this would be 2490*l.* sterling.

† About 130*l.* sterling.

‡ On submitting the above estimate of cost for condensing milk to Mr. Gail Borden, he states that some of the figures are put altogether too low. To condense 5000 gallons of milk per day, he says, would require a larger capacity of vacuum-pans, more coal, and a larger number of workmen than given in the items furnished to Prof. Chace. The views of so experienced an operator as Mr. Borden must be taken as quite reliable, and I give them here in order to correct any wrong impressions that might result from a too low estimate. I endeavoured to give only an approximate estimate of cost.—X. A. W.

the cost of condensing, with the same expenses as before, would be nearly  $1\frac{3}{4}$  cent per gallon, or less than half a cent per quart. This, it must be understood, is for plain milk. When sugar is added, the expense of the sugar must be reckoned; but as sugared milk is sold by the pound, and as the addition of sugar adds something to the weight, the increased weight more than pays the cost of the sugar.

In a well-conducted factory, therefore, and when milk can be purchased at  $12\frac{1}{2}$  cents (about  $6d.$ ) per gallon, the cost of condensing is from 1 to 2 cents ( $\frac{1}{2}d.$  to  $1d.$ ) per gallon, and this includes the value of a certain number of gallons of crude milk daily set apart to cover waste, which possibly may not occur.

When the milk is put up in pound cans, the 5000 gallons of milk condensed, allowing for waste as previously estimated, would require 10,000 tin cans, which at 30 dollars per thousand—the estimated cost—would amount to 300 dollars, or 6 cents ( $3d.$ ) for every gallon of crude milk condensed.

The whole expense, then, of condensing and canning the 5000 gallons, would be at the rate of 7 cents per gallon, of crude milk. For the 2000 gallons, it would be 8 cents per gallon. That is to say, in English money the expense would be  $3\frac{1}{2}d.$  per gallon in the first case, and  $4d.$  in the second.

The daily expenses, then, may be summed up as follows:—

	dollars.	cents.
Cost of 5000 gallons of milk .. .. .	625	
Daily working expenses of factory as previously estimated	24	50
10,000 cans (30 dollars per 1000) .. .. .	300	
	<hr/>	
	949	50
To this must be added expense of sealing up and labelling the cases, say 1 cent per can .. .. .	100	
	<hr/>	
	1049	50

The daily product of the factory, would be 10,000 pound-cans of sugared condensed or preserved milk, which, at 29 cents per can, amounts to 2900 dollars, leaving a balance of 1850 dollars 50 cents above the expenses for the day's operation. But the milk now must be marketed, and this I shall treat in another place.

The delivery of 5000 gallons crude milk per day would require the product of 1660 cows, allowing each to yield on an average three gallons of milk per day.

If we estimate for a smaller number of cows, as within an easy reach of most factories in the dairy districts, the 2080 gallons would represent, say 660 cows. For this quantity the account would stand thus:—

	dollars.	cents.
Cost of 2080 gallons of milk at 12½ cents per gallon ..	260	
Daily working expense of factory as before estimated ..	24	50
4160 tin cases, 3 cents .. .. .	124	80
Filling, sealing, labelling cans (1 cent) .. .. .	40	
	<hr/>	<hr/>
Total .. .. .	449	30
Product :—4160 cans of Sugared Condensed Milk, at 29 cents per can .. .. .	1206	40
	<hr/>	<hr/>
Daily balance above expenses .. .. .	757	10

*The Vacuum Pan.*—In order to show how milk is condensed *in vacuo* it may be well to give an illustration of some of the modern improved machinery employed for this purpose.

Fig. 3, on p. 122, represents an improved cast-iron Vacuum Pan. Different liquids, as is well known, boil at different temperatures, and the same liquid may be made to boil at any temperature, from the freezing point up, according as the pressure upon its surface is taken off or increased. If by reason of boiling in confined space, the pressure upon the surface is increased, so that steam cannot readily pass off; the heat accumulates to a greater degree than 212°, till the steam acquires sufficient elasticity to overcome this increase of pressure. At the bottom of deep mines the increased pressure of the air has the same effect, and steam is not generated at so low a temperature as at the surface. As the pressure is diminished, either mechanically by the use of the air-pump, or by ascending elevations, steam is generated, and passes off freely, at lower temperatures than 212° F. On high mountains it may be difficult to produce sufficient heat in open vessels even to boil eggs; Darwin was led to notice this, when he ascended with his sailors one of the mountains of Patagonia. They took with them a new pot, in which they attempted in vain to boil potatoes. But for the pressure of the atmosphere, the ocean would boil and evaporate with heat equivalent to that of the sun's rays. Several ingenious experiments have been devised to illustrate these facts. The simplest is in making a glass of warm water boil under the receiver of an air-pump. The pulse-glass consists of two glass bulbs, connected by a glass tube. The fluid in one is made to boil by holding one of the bulbs in the warm hand. This property of fluids, of being converted into vapour at different temperatures, is made to serve important purposes. Liquids intended to be evaporated, are sometimes partially freed from the pressure of the air, and are thus boiled "in a vacuum" with economy of fuel. This process is adopted with great success in sugar refining.

When the temperature of the usual boiling point would injuriously affect the liquid to be evaporated, as milk for instance,



it is advantageously boiled with reduced pressure, at a low temperature. Syrups are evaporated, as in the refining of sugar, in vacuum pans, or vessels in which the atmospheric pressure may be partially taken off by air-pumps. A low degree of heat only is thus required, producing economy in fuel, and avoiding the risk of over-heating and burning the syrup. With these well-known principles in mind, dairymen will be able to see the advantages obtained by Mr. Borden in using the vacuum pan in expelling the water from milk. It will be observed, too, that from the moment the milk enters the pan, it is protected from various harmful influences, such as dust, flies, and other insects, which are liable to be caught in the liquid, when evaporation is carried on in an open vessel, as under the Provost method.

In Europe, and, indeed, in the United States, until quite recently, vacuum pans have been formed of copper; but owing to the high price of this metal, the temptation is to make them as thin as possible; and the collapse of the pan, owing to the external atmospheric pressure, is not an unfrequent occurrence. In America the substitution of cast iron has, in a great measure, obviated this difficulty. I am told that the cast-iron pans for condensing milk are employed with quite as much success as those made of copper, and Fig. 3, on the next page, is an illustration of an iron pan, showing one of the best forms of construction in this material. The engraving shows three coils of pipe, but, for condensing milk, generally but one—the lower coil in the pan—is used, and the coil is arranged to run round the inside surface of the pan rather than across the pan, as in the figure, in order to facilitate cleaning. I am indebted to the *Technologist*, for the illustration and description of its parts. The drawing is well arranged to give a good idea of the manner in which solutions of sugar, and other organic substances, may be evaporated at comparatively low temperatures, and I deem it important to a clear understanding of what I shall have to say with regard to the preparation of condensed milk.

The pan A (Fig. 3) is of any size, from 4 to 10 feet 6 inches in diameter, and is cast in four pieces: A<sup>1</sup> being the bottom, A<sup>2</sup> and A<sup>3</sup> shells, and A<sup>4</sup> the dome-piece. B is the dome, connected by the vapour-pipe C, to the catcher D, the latter being a cylindrical vessel, divided part-way by a partition or apron, D<sup>1</sup>, against which, in case of boiling over, the liquor would be dashed, and would gather in the bottom, where the amount can be seen at the glass-gauge, d<sup>1</sup>, and, if necessary, emptied into the pan by means of the faucet and pipe d.

From the top of the catcher D, the vapours are conducted by pipe E to the condenser E<sup>1</sup>, which is placed 33 feet above the

water-level in the basin C, to which the condenser is connected by the stand-pipe F. The water rises in the latter to about

Fig. 3.—*Improved Cast-Iron Vacuum-Pan.*

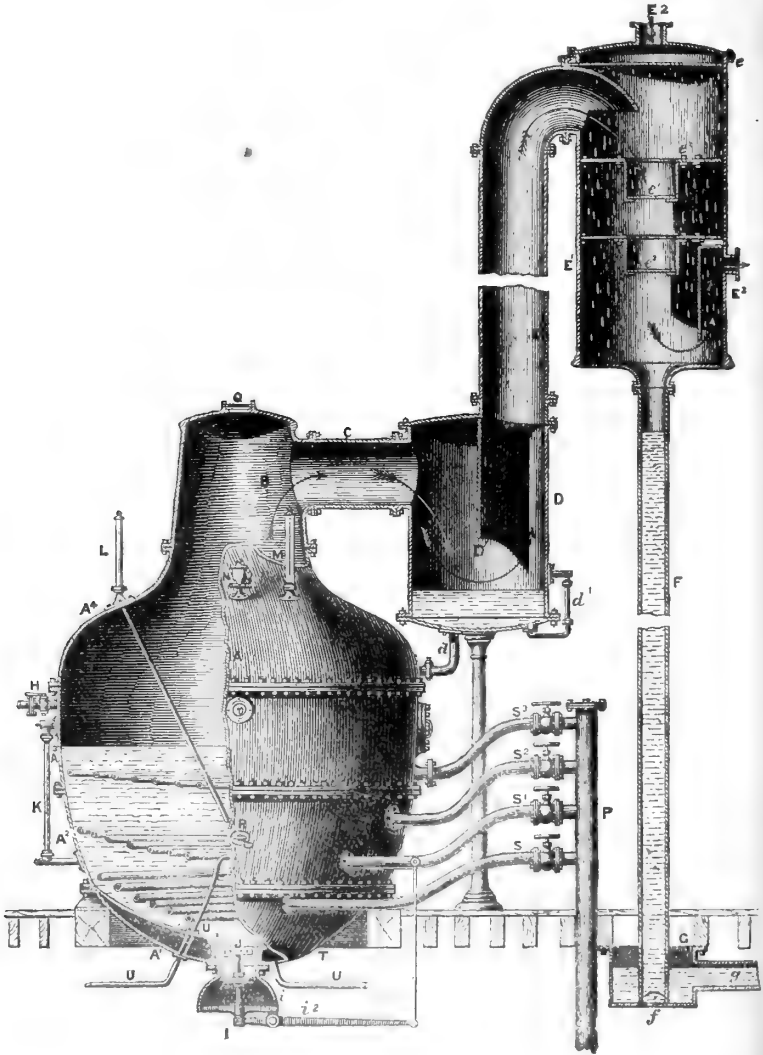

30 feet, more or less, according to the amount of vacuum, and is held therein by the atmospheric pressure on the surface of the water in basin G, the condensing water added flowing off from

G by overflow *g*. The condensing water enters the condenser at  $E^2$ , falls over the sieve-plates  $e e^1 e^2$ , and comes in direct contact with the vapours, which have to pass also through the openings in the sieve-plates  $e^1 e^2$ , by which arrangement the greatest condensation is produced with the least amount of water. At  $E^3$ , the vacuum-pipe, in this case a dry one, is connected.

To prevent the condensing water from being drawn along with the vapours to the pump, the opening  $E^3$  is guarded by an apron. H is the pipe through which the liquor enters the pan. I is the drop-valve, composed of a rubber-disk *i*, between two plates on the end of the lever  $i^2$ —a simple and most effective construction, the pressure of the outside air holding the valve perfectly tight;  $i^1$  is a semi-globular casing, which prevents the liquor from spreading too much when it is discharged. On the end of the valve-stem is fastened a scraper J, intended to break any crust of crystallised sugar that may have formed, as any such crust, unless removed, would, of course, obstruct the exit of the liquid.

The regular mountings of the pan consist of a man-hole; a thermometer L, the tube of which is enclosed in a pipe *l*, and reaches to the centre of the boiling liquor; a vacuum gauge M; a glass gauge K, by means of which the quantity of liquor in the pan is observed; a butter-cup N—butter quieting the liquor if it shows a tendency to boil over; an eye-glass O, opposite to which is another similar glass, through which a lamp gives light to the interior of the pan. Q is a light glass on the top of the pan, through which the entire surface of the boiling liquor may be illuminated, and R is the tester, by means of which proofs are drawn to see how far the process has advanced.

Heat is applied in the following manner:—the bottom of the pan is double, and steam is admitted thereto by the pipe P, the upper shell, which forms the heating surface, being generally of copper. The steam also passes through one, two, three, or even four coils, according to the size of the pan, and the amount of water to be evaporated in a specified time. P is the steam branch. The pipe S leads to the bottom,  $S^1$  to the lowest coil,  $S^2$  to the middle coil, and  $S^3$  to the upper one. As fast as the steam is condensed the water is led by the pipes U U from the bottom, and coils to a steam trap.

It might, at first, be supposed that cast iron would fail to resist the corroding action of solutions, but the results of practice show that the scale, which in every case covers the metal, protects the pans completely. And as the liquor is in all cases charged to some extent with lime, the pan speedily becomes covered with a fine scale or fur, which effectually prevents all

injurious action. This is especially the case if the pan be worked continuously, but, if long stoppages are made, copper possesses decided advantages over cast iron. Under ordinary circumstances, however, the cast-iron vacuum-pans answer every purpose, and they can be constructed in such a perfect manner that one similar to that described will retain a vacuum of 29 inches for a space of twelve hours without losing more than one inch.

*The Improved Vacuum-Pump.*—I have said that when milk, solutions of sugar, and most organic substances, are to be evaporated, it is found necessary to expose them to as low a temperature as possible, so as to avoid decomposition, and for this purpose the boiling *in vacuo*, in a so-called vacuum-pan, is of especial advantage. The vacuum is produced by a pump, which first removes the air from the pan, and afterwards the vapour arising from the boiling liquid. Figs. 4 and 5, on the next page, represent a vacuum-pump, which, for correctness of the principles involved, and for the manner in which they have been carried out, is worthy of special attention. "It has," says the *Technologist*, from which I have taken my description, "already been subjected to the most severe tests in many sugar-houses." Hitherto a great deal of annoyance has been experienced, owing to the bad proportions and worse construction of many machines applied to this purpose, as a falling off in the vacuum affects the result very materially, and any stoppage of the machine owing to a break-down, &c., arrests the whole operation, and entails a serious loss. This machine is, strictly speaking, an independent vacuum-pump, and as it is confined to the duty of forming a vacuum, it may be worked at that speed which will afford the very best result without interfering in any way with any other operation.

In the accompanying engravings, Fig. 4 is a side elevation, the pump-cylinder being partly in section, to show the valve-plate and valves, and Fig. 5 is a plan, similar letters indicating the same parts in both figures. A is the steam-cylinder; B the valve-chest, arranged as is usual in a steam-engine; C the steam pipe; D the exhaust-pipe. The engine is a so-called back-acting one, the crank-shaft being placed between the cylinder and the cross-head. This involves a necessity for two piston-rods, E E<sup>1</sup>, the former passing over the shaft and the latter underneath it. F is the cross-head; F<sup>1</sup> the slides; G the connecting-rod; H the crank and crank-shaft; H<sup>1</sup> the pillow blocks; I the fly-wheel. J is the pump piston-rod, which is extended beyond the piston, and passes out on the other end of the pump-cylinder through a stuffing-box, the piston being consequently carried at two points, so as to reduce as much as

possible the unequal wearing of the cylinder. K is the pump-cylinder, one-half of which is shown in section, to exhibit the

Figs. 4 and 5.—Plan and Section of the Improved Vacuum-Pump.

Fig. 4.

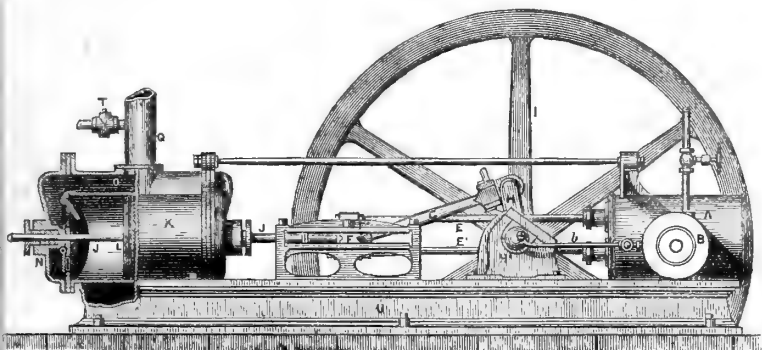
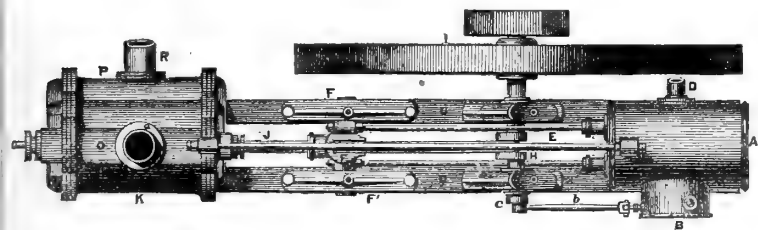

Fig. 5.



arrangement of the valves. The end of the cylinder forms the flat valve-plates, in which are imbedded the induction-valve M, and the eduction-valve N, the former connecting with the induction-passage O, and suction-pipe Q; the latter with the eduction-passage P, and exhaust-pipe R. L is the pump-piston, which moves up to the valve-plate, as closely as the case will admit, to expel as much air as possible. A small quantity of water is also admitted for this purpose at T in the suction-pipe.

In what is known as a dry vacuum-pump, to which class of machines this belongs, it is of the greatest importance to leave the least possible amount of dead space in the cylinder between the piston and the valves, when the piston is at the end of its stroke; because, on expelling the vapour, the amount that fills this space remains, and reduces the capacity of the pump, in the proportion that this space bears to the capacity of a single stroke of the pump, multiplied by the ratio of the density of vapour,

at the time of expulsion, to its density when introduced into the cylinder; and for the same reason it is of equal importance that the stroke of the pump be made as long as convenience will allow, in order to lessen the effect of the contents of this dead space. The piston moves up to the valve-plate, to within one-sixteenth of an inch, which space is always filled by a small quantity of water, admitted at the water-cock T. The valves lie down flat with the plate, so that very little loss is occasioned by them, while the stroke of the pump is made long for the reason above specified.

The pump-valves are of peculiar construction, having been devised by Mr. A. S. Cameron, of New York City. It is well known that valves made from metal alone cannot be kept tight for any length of time, as the pounding of metal on metal soon renders their surfaces uneven; while, on the other hand, valves made wholly of rubber are destroyed by being forced into the openings of the valve-seats, making it necessary to renew them frequently. In this valve both of these difficulties are overcome, by combining both metal and rubber in its construction. The body of the valve consists of a casting of brass, or any other suitable metal, provided with an annular groove or dove-tailed recess, corresponding with the shape of the valve-seat that the valve is intended to cover. This recess in the valve is filled with indiarubber in a raw or plastic condition, which is then vulcanised while in its place at a temperature of 350° Fahr., allowing it to project a sixteenth of an inch beyond the metallic surface.

From this it will be seen that, when in operation, the projecting rubber comes in contact with the smooth surface of the valve-seat, making a perfect joint, while the body of the rubber, being confined in the groove, is incompressible, and, in fact, indestructible by ordinary agents. And then a valve is obtained combining in itself all the good qualities of metal and rubber to give strength and tightness, while the objectionable features of a valve made wholly from either are overcome.

The lining of the vacuum-cylinder, its piston, piston-rod, valves, and valve-seats, are all made of composition, to prevent any injurious effects from the acids with which they may come in contact. The whole machine, in fact, has been carefully studied, and is well adapted to the duty for which it is intended.

Having now described the latest improvements in machinery for evaporating *in vacuo*, it only remains to give an illustration (Fig. 6), showing Messrs. Guild and Garrison's pan and pumps, now in use at some of the factories, and with it I shall close this branch of my subject.

FIG. 5. — View of Messrs. Guild and Garrison's Vacuum-Pan and Pumps, showing the position of the Machinery.

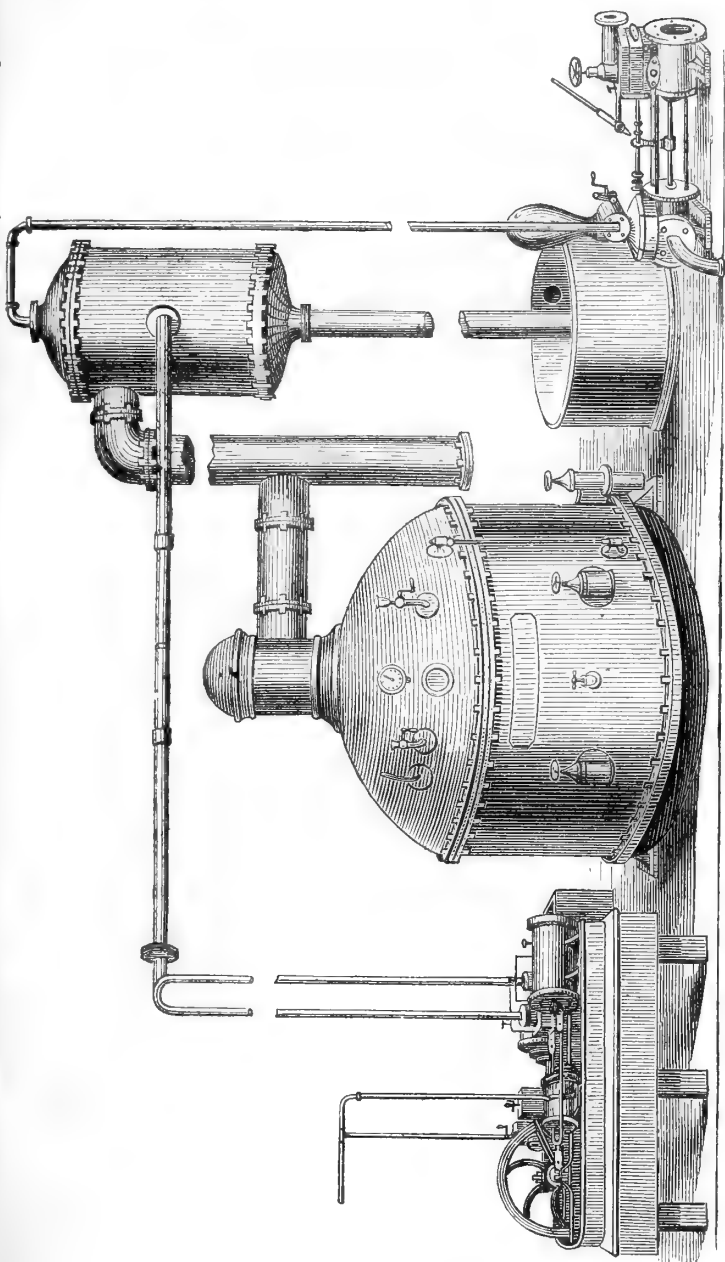

## PROCESS OF CONDENSING.

In some of the recently erected factories an improvement has been made in heating tanks, in cooling vats, and in the manner of arranging these appliances, whereby the milk can be manipulated with more ease, or be turned to other purposes besides condensing. The plans of factories previously given are arranged for the condensing process alone. The new factories are more elaborate in their arrangements, and combine all the conveniences of the cheese and butter factories, as well as those for condensing milk. I shall presently describe one of these establishments, the best of its kind in America, and designed to be a model in all its internal machinery and appliances. Meanwhile, the general features of the condensing process may be briefly stated. The milk is delivered at the factory in small cans, holding about 40 quarts each. They are filled quite full, and have a tight-fitting cover. It is understood, of course, that the treatment of the milk at the farm has been in accordance with the rules previously given. Then, as the cans are placed upon the factory platform, the covers are removed, and each is subjected to a rigid scrutiny by the factory manager, with a view to discover any imperfection. Imperfect milk can often be detected immediately after removing the can-cover, from its odour; but if it is left for a few moments thus exposed to the atmosphere the odour escapes, so that the milk, though imperfect, may pass undetected. The examination of the milk as it comes to the factory, and the facility of the manager in determining its condition, will have much to do in securing a uniform good product; and it is important that this matter should be well understood. The examination should be rigid, and the manager should have sufficient decision of character to reject every sample of milk which is not found to be in good order. After the milk is received it passes through a strainer to the receiving-vat; from this it is conducted off, going through another strainer into the heating-cans, each holding about 20 gallons; these cans are set in hot water, and the milk is held in them till it reaches a temperature of  $150^{\circ}$  to  $175^{\circ}$  Fahr.; it then goes through another strainer into a large vat, at the bottom of which is a coil of copper pipe, through which steam is conducted, and here the milk is heated up to the boiling point. Then the best quality of white granulated sugar is added, in the proportion of one and a quarter pound of sugar to the gallon of milk, when it is drawn into the vacuum-pan, having a capacity of condensing three thousand quarts or more at a time. The milk remains in the vacuum-pan subjected to steam for about three hours, during which time about seventy-five per cent. of its bulk in water is removed, when it is drawn off into cans, holding 40 quarts



each. The cans are only partially filled, and are then set in a large vat containing cold water, the water being of a height equal to that of the milk in the cans. Here it is stirred until the temperature of the condensed fluid is reduced to a little below  $70^{\circ}$ ; it is then turned into large drawing-cans with faucets, in order to facilitate the filling of the small cans. The drawing-cans stand in a room which is set apart for the purpose, and around the outside of which runs a table or workbench. Here the milk is drawn from the faucets into the small tin cans holding a pound each, when they go to the table and are immediately soldered to exclude the air. The cans next have the proper labels pasted upon them and are then ready for market. The work of filling the cans, soldering the tops, and labelling, is usually performed by females. A number of small soldering-furnaces are placed along the tables, where the girls, each with a set of soldering-irons, seal the cans as fast as they are brought forward by the fillers.

This is the plan of operations at the Elgin factory, which is somewhat noted for its fine product.

In one of the upper apartments of the Elgin factory is the tin-room. Here a number of females are employed making the small tin cans. There are machines for cutting out the circular parts of the can at a blow, and the putting together and soldering are very expeditiously effected and at the least expense, since all the material is purchased at wholesale prices, and the employment of females is less expensive than that of males, while at the same time the work is quite as neatly and substantially made as at the regular shops where males are employed.

#### MR. GAIL BORDEN'S FACTORY AT BREWSTER, NEW YORK.

In December I visited Mr. Borden at White Plains, and inspected all the departments of his factory at Brewster. He has met with great success in the sale of his condensed milk, and deservedly so, because he puts upon the market only a perfect article. The factory at Brewster is an immense establishment, and every part of the business is conducted with the regularity of clockwork. The building is situated on a small stream, where there is a seven-foot fall, and the water is thus utilized for running the pumps, which makes a considerable saving in fuel during the year. The factory has two vacuum-pans, but only one was in operation at the time of my visit. It is a six-foot pan, with two coils of pipe; and 2000 quarts of milk per hour is the usual rate of condensing. Mr. Borden now believes in doing the work rapidly, and says the sooner you can get the milk from

the cow into a condensed form the better. He therefore uses two boilers of 55-horse power each for supplying steam to the pan. The average pressure of steam in the pipes at the pan is 55 to 60 lbs. to the square inch. The evaporation goes on best in clear dry weather. In damp foggy weather it takes a little longer to get the milk out. About 10,000 quarts are now being condensed per day. The milk, as it is received, goes into two square-like boxes or vats, the receiving-room being four or five feet higher than the bath and heating-room. The bath-tubs are circular, and have a coil of steam-pipe at the bottom. The bath-tubs are filled within six or eight inches of the top with water. The heating-wells are of copper, egg-shaped, and stand opposite the bath-tubs, a raised platform running between the two. The milk is drawn through a hose from the receiving tanks into copper cans setting in the bath-tubs, each one holding about 40 quarts. Here the milk is heated to from  $150^{\circ}$  to  $175^{\circ}$ . It then goes to the heating-wells, which have a jacketed bottom for steam, and in them is heated up to the boiling point. It is then immediately drawn to the vacuum-pan. A stream of milk is kept flowing into the pan about as fast as the evaporation goes on, or at the rate of about 2000 quarts per hour.

Fig. 7.—*Heating-Room at Borden's Factory at Brewster.*

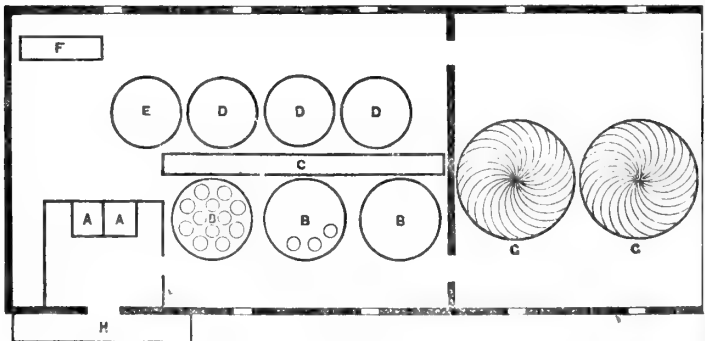

- |                           |                            |
|---------------------------|----------------------------|
| Delivery.                 | E. Sugar-dissolving Well.  |
| A, A. Milk Reservoirs.    | F. Vacuum-Pump.            |
| B, B, B. Hot-water Baths. | G. Boiler, 55-horse power. |
| C. Raised Platform.       | H. Platform.               |
| D, D, D. Heating Wells.   |                            |

When the sugared milk is to be made, the amount of sugar is calculated for the given quantity of milk, and then turned into a moveable tank or well, and here the hot milk is poured upon it until it is thoroughly dissolved. The hot sugared milk is drawn up last in the pan, and mingled with the milk which

has been partially condensed. The sugared milk must be deprived of more water than the plain milk, since the addition

Fig. 8.—Heating-Well, with Jacketed Bottom for Steam, used at Borden's Factory.

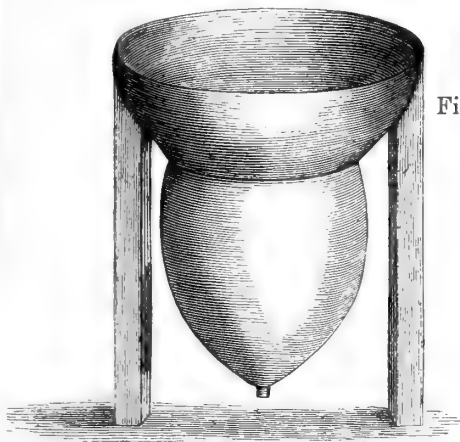
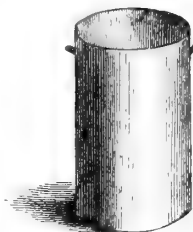

Fig. 9.—Copper Heating-Can for the Bath Tubs, used at Borden's Factory.



of sugar partially liquefies the mass—a curious fact. Three pints of milk make a pound of sugared milk. The three pints of raw milk will weigh on an average 3 lbs.  $3\frac{3}{4}$  ozs. Now, by abstracting 75 per cent. of water ( $38\frac{5}{10000}$  ozs.), we have remaining 12 ozs. and  $\frac{855}{10000}$  of an ounce; add to this the proportion of sugar now used,  $6\frac{3}{4}$  oz., or about  $3\frac{6}{10}$  ozs. more than a pound, and it will be seen this  $3\frac{6}{10}$  ozs. of water have to be removed in addition to the 75 per cent. of water in the first instance. Mr. Borden told me that the matter of getting the right proportion of sugar was the result of long study and numerous experiments, and no other proportions gave such good results in the product.

The plain condensed milk is reduced from 4 to 1. It is treated in the pan precisely like the other, except near the close of the operation, when the vacuum in the pan is broken, and the mass superheated, or raised to a temperature of  $190^{\circ}$  to  $200^{\circ}$ . The superheating process was discovered in 1862, and this is one reason which gives the Borden brands their superiority in the market. The superheating not only helps the keeping qualities, but prevents granulation.

During the superheating process, the water which passes off has an intensely disagreeable odour. The heat in the vacuum-pan throughout the whole of the Borden process, apart from

superheating, is kept at a temperature of from 135° to 145° Fahr.

At the Borden factory they have a filling machine by which two women will fill 10,000 pound-cans per day (of 10 hours). In the old way the women would fill but 3000 cans in 10 hours. Two women will put the labels on 10,000 cans in a day, and one woman will seal or solder up 1200 cans per day. The machinery for making cans here is very complete: fourteen boys at tops and bottoms and soldering-in machines, with one man cutting bodies; will make 11,000 cans per day; the expense being about 2 $\frac{3}{4}$  cents per can for labour and material, all told.

This factory sends to New York daily about 50 forty-quart cans of plain condensed milk, which is sold at from 40 to 50 cents per quart.

The question may occur,—Why is the milk heated in the bath and then in the wells? and why not heat all in one place? Mr. Borden says milk cannot be heated to the boiling point in one vessel except at great loss from adhesion to the metal, besides causing great trouble in cleaning. The heating in two places avoids this.

At this factory they have a “can-washing machine,” which does the work in a moment by machinery. Mr. Borden, in describing his process to me, said (and I give his exact language) as follows:—

“The milk is brought up to about 150° to 175° in the bath, then poured into the heating-well, where it is brought to a boiling heat, and from thence drawn into the pan by atmospheric pressure produced by the air-pumps. The sugar is dissolved with a portion of the boiling milk taken from the heating-well.

“The making of a good article of milk depends not so much upon the formula in the best specification *as upon the condition of the milk when brought to the factory*, and the care and attention given to every part of the process, from the washing of the vessels and the thorough cleanliness which should be observed in every department. The success of the milk manufactured at our three factories, known as the ‘Gail Borden Eagle Brand,’ is due to the attention which we give to the personal inspection of every department of the dairies on the farms, which is assigned to one person at each factory; the constant examination of every man’s milk by samples taken and subjected to tests as to cream, sweetness, and the time it will keep after being brought from the dairies; in short, there is nothing manufactured requiring so much care and everlasting vigilance and attention as milk. From the time it is drawn from the cow until hermetically sealed in the can, it requires that everything should be done with the utmost integrity.

“I am assured from what I see in your writings on the subject of milk as applied to the making of butter and cheese that you fully concur in all I have said in relation to the subject. We both realize that it is for the want of a full understanding of the delicate character of milk that so many have failed in producing a good article either of cheese or condensed milk.”

*Cleaning the Vacuum-Pan.*—After condensing the milk and drawing from the vacuum-pan, the pan must be thoroughly cleaned. For this purpose there is a man-hole, by which a person can enter the pan and do the work with brushes, sand-paper, and water. I am told that for a long time Mr. Borden experienced considerable difficulty in having the pans properly cleaned, as the milk during the process of condensing would adhere to the metal and bake or harden into a crust. After a while it was discovered that by oiling the metal on the inner surface of the pan this difficulty could be obviated.

The discovery was made through merely accidental circumstances, and from observing an old housewife “grease the pot,” preparatory to making “minute pudding.” On applying the principle to the vacuum-pan it was found to prevent the milk adhering to the metal, and a patent was at once secured upon it. Introducing a little water in the pan just before drawing in the milk effects the same object. This is one of the secrets of the condensing business.

*Gauging the Milk.*—Difficulty is sometimes experienced in determining when the milk is reduced to the proper consistency. In regulating this, samples of condensed milk are drawn from the pan, and the amount of water removed is judged from its specific gravity and appearance on cooling.

Errors not unfrequently occur in carrying the condensing process too far, especially with persons who have not a correct eye, or who may become a little careless at times. I am told that a gauge placed in the pan is an important aid in this matter. The quantity of milk to go into the pan being noted, the gauge indicates the amount and rapidity of the evaporation, and thus renders important assistance in regulating this essential point in the process; for it must be observed that, if the reduction is carried beyond 75 per cent., there is not only a loss in weight, but the consistency not being uniform will have its influence on sales; and the quality is also liable to be deteriorated.

The plain condensed milk has the same amount of water removed, and is treated in the same way as that which has been described, except that no sugar is used in its manufacture. It is not put up in sealed cans, but will keep sound for several

days, and is intended for present use. It is sent to market in cans holding 40 quarts each.

Fig. 10.—*Non-conducting Carrying-Can.*



Recently, a "non-conducting can" has been invented for shipping this kind of milk. It is of tin, and nearly of the same form as the carrying-cans, but double, with a space of 2 inches between the outer and inner surface, which is closely packed with ground felt. Fig. 10 shows the general form of this can. In these cans the milk goes to market in sound condition.

#### THE COMBINED FACTORY.

I have alluded to the modern plan of combining with the manufacture of condensed milk that of cheese and butter; in other words, the fitting up of a factory in which either the one or the other or the whole of these products can be made from the daily delivery of the milk. Experience has shown that the combined factory is the safest, and in most instances should be adopted. There are certain seasons of the year when it is more difficult to make good condensed milk than at others. There are times, too, when the milk received does not prove to be in that prime condition necessary for condensing, but which might suffice for the manufacture of cheese. Again, the breakage of machinery might render it impossible to condense the milk for a day, and perhaps for longer periods; changes in the market may also render it advisable to put a smaller quantity of milk through the condensing process for a day, a week, or a month, than at other times.

These, and a variety of other circumstances occurring, or liable to occur, require at the factory ample means for manufacturing the milk into some other form than that of condensed milk. For it must be observed, that after a number of persons have been engaged to deliver milk at the factory, it must be received, if in good order; and, unless provision be made for its manufacture in some form, heavy losses will ensue. When arrangements are perfected for turning the milk into

butter or cheese or condensed milk at pleasure, advantage may be taken of any circumstance, and the milk can be properly disposed of not only without loss, but to the best advantage. There are other reasons for the construction of factories upon this plan, which I shall name hereafter under their appropriate headings.

The factory plans presented in Figs. 11 to 13, are those of the MIDDLETOWN FACTORY, on the Erie Railway, about 60 miles from New York city. This establishment was erected, during the year 1870, at a cost of more than 50,000 dollars, and is probably the most convenient and best furnished in its internal fittings of any combined condensing factory in America.

Fig. 11.—Plan of Basement of Middletown Milk-Condensing Factory.

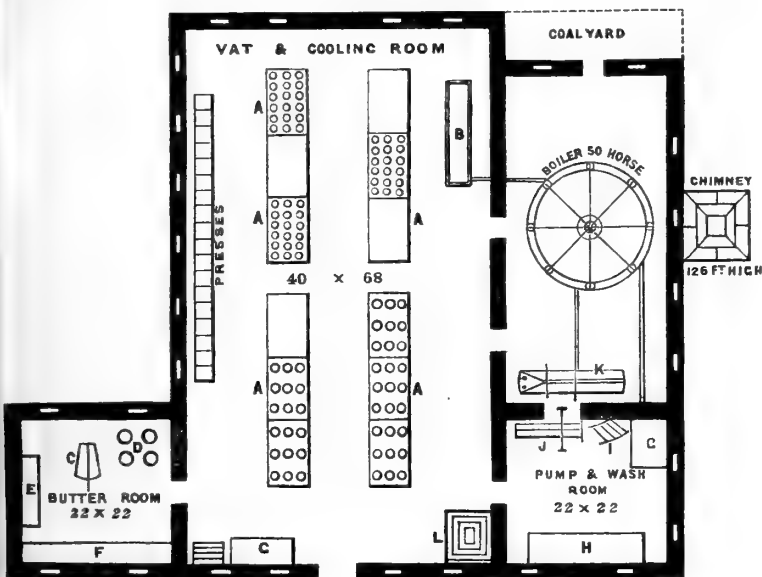

- |                                    |                       |
|------------------------------------|-----------------------|
| A, A. Water-Vats for cooling Milk. | G, G. Hot-Water Vats. |
| B. Cheese-Vat.                     | H. Cold-Water Vat.    |
| C. Butter-Worker.                  | I. Stairs.            |
| D. Churns.                         | J. Pump.              |
| E. Water-Vat.                      | K. Engine.            |
| F. Table.                          | L. Lift.              |

The ground floor, or basement, is partly below the surface of the ground. The height of the rooms is about 9 or 10 feet between

floors; and the lower floor being about 6 feet below the level of the ground, built in with heavy walls and thoroughly underdrained, gives a low even temperature all the year round. The floor is covered with stone flagging nicely laid in cement, so as to make a perfectly tight bottom where no accumulation of water or filth can find an entrance. It may be observed here that all condensing factories should have basements similarly constructed, since, by securing a low and uniform temperature, the milk can be kept in better order, and a better product can be secured.

The main building is 40 x 68 feet, three stories; with wings,

Fig. 12.—Plan of Second Floor of Middletown Milk-Condensing Factory.

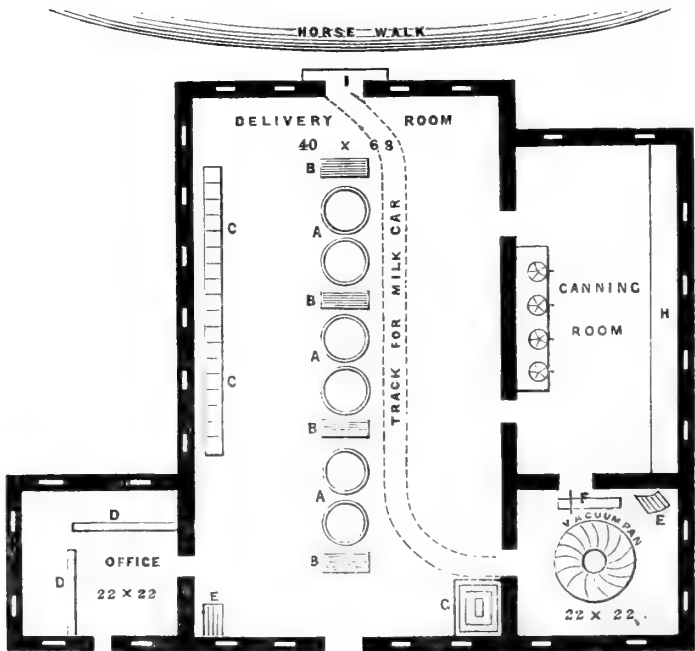

- |                       |                     |
|-----------------------|---------------------|
| A. Heating Tanks.     | F. Pump.            |
| B. Ventilators.       | G. Lift.            |
| C, C. Cheese-Presses. | H. Table.           |
| D, D. Desks.          | I. Delivery-Window. |
| E, E. Stairs.         |                     |

22 x 22 feet on the left, and 22 x 50 feet on the right, two stories high. The basement is divided into churn-and-butter-



room to the left, 22 × 22 feet; vat-room, 40 × 68 feet, containing the cooling-vats, cheese-vat, elevator, presses, &c., with steam-pipes and hose leading to various parts of the building. The room to the right is the pump- and wash-room, 22 × 22 feet, with scalding and cold-water vats, vacuum-pump, &c., and containing the lower portion of the vacuum-pan projecting through the ceiling from above. Out of this, and along the side of the main building is the boiler and engine room. The boiler is 50-horse power.

On the second floor of the main building (Fig. 12, p. 136) is the delivery-room, 40 × 68 feet. Here are the heating-tanks, of galvanised iron or of tin, with jacketed bottom of copper, in which steam is admitted to heat the milk. They are each 4 feet in diameter and 6 feet long, rising about 28 inches above the floor, and extending through the floor into the room below. Between each two tanks is a ventilator, communicating with the room below and running to the roof. Openings are provided in each room, so as to give thorough ventilation. A track for the milk-car runs from the delivery-window alongside of the tanks and extends to the elevator, so that as fast as the milk is delivered the cans are placed in the car, and thus conveyed to the tanks and dumped; or the milk may be placed on the lift and lowered to the room below. This room is double-floored, and the floors are laid in cement, so as not to allow leakage. On the left is the office, 22 × 22 feet, furnished with desks, &c. On the right is the vacuum-room, 22 × 22 feet, with the vacuum-pan in the centre, the lower part of which extends through the floor and into the room below, where the condensed milk is drawn from the pan. The communication between the two rooms is by stairs. Here also are the condenser and the pumping machinery. At the back of the vacuum-room the canning department, where the milk may be drawn from the filling-cans into pound packages, and then sealed and labelled.

The third or upper floor (Fig. 13, p. 138), is the cheese-curing department, provided with racks and tables for the reception of the cheese.

Near the ceiling of the basement are iron shafts connected to the engine by gearing, by means of which the churns are driven, the lift is raised or lowered at will, and power is transmitted for all other work requiring it. Cold spring water flows in and out of the cooling-vats and other water-tanks, while steam is conveyed by pipes from the boiler to the heating-tanks and to other parts of the building as desired. The whole structure above the basement walls is of brick, and the boiler-chimney, 126 feet high, is very substantially built. Of course, a factory, embracing the same ground-plan could be erected much cheaper, as this

building and its fixtures have been constructed in the most expensive manner.

Fig. 13.—*Plan of Third Story of Middletown Milk-Condensing Factory.*

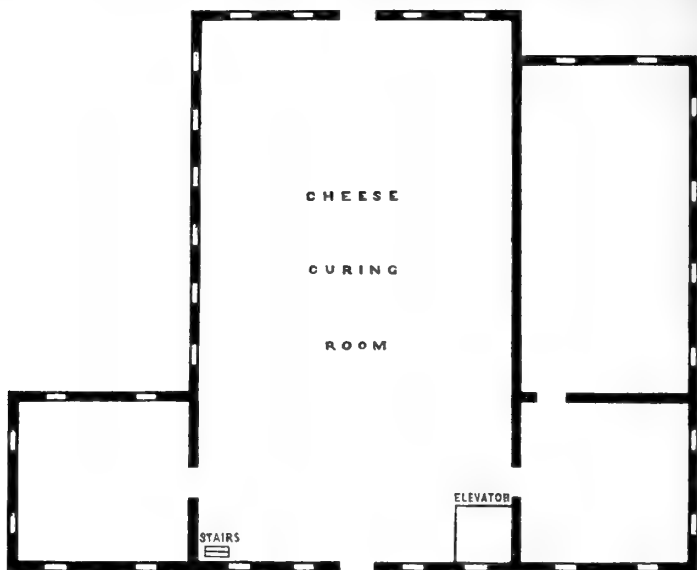

### CONDENSING SKIMMED MILK.

Plain condensed milk is varied in manufacture as follows:—

I. By using whole milk, or milk containing all its own cream.

II. By mixing skimmed with whole milk. When this is done, the skimmed milk is first drawn into the vacuum-pan, and after its volume has been reduced considerably, the whole milk is added, and the mixture then reduced to the required consistency.

III. By condensing the skimmed milk alone.

At the Middletown factory skimmed milk is extensively used for condensing. After the milk has been taken from the delivery window and dumped into the heating-tanks, steam is admitted to the jacketed bottom, and the milk heated to  $130^{\circ}$ . A small quantity of alum and saltpetre is sometimes added to the milk, for the purpose of clarifying it more readily. During the heating process the impurities in the milk rise to the surface, and are skimmed off, and when this has been effected (the time of heating ranging from one and a half to two hours) the milk is

ready to be drawn either into the vacuum-pan or cooling-pails. These pails are 8 inches in diameter by 22 inches long, with iron bails, and are set in the vats containing cold flowing spring water. The vats are placed in the basement as before described.

The pails are filled by attaching a rubber hose to the bottom of the heating-tank, where there is a faucet with a tube going through the jacket to the milk. The operator then carries the hose from one pail to the other, and they are thus filled rapidly.

Fig. 14 represents a cross section of the basement and second floor of the factory, with heating-tanks and cooling-vats, showing the manner in which the milk is drawn into the pails.

Fig. 14.—Cross Section of the Basement and Second Floor of the Middletown Milk-Condensing Factory, showing the manner of draining the milk from the heating-tanks into the cold-water vats.

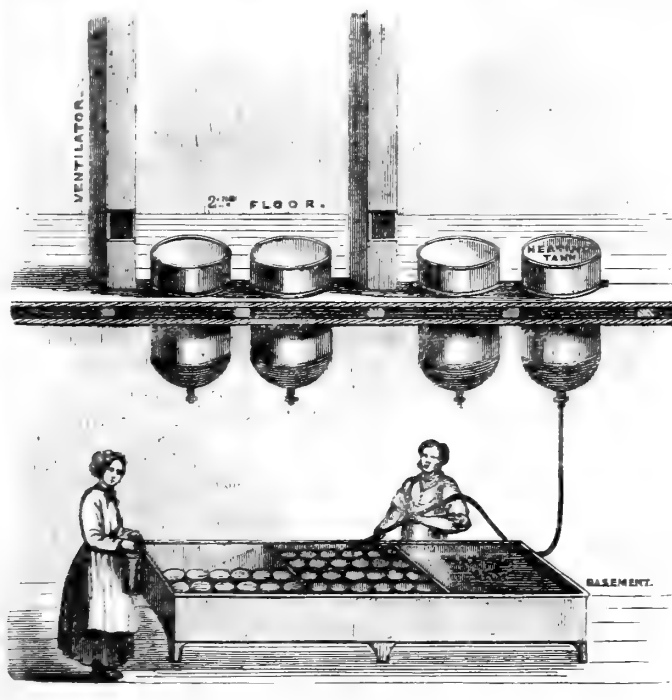

The cooling-vats, four in number, are each 21 feet long by 4 feet wide, made of 3-inch pine plank, and separated into three divisions. Here the milk sets from eight to twelve hours,

according to the character of product which it is desired to obtain. After the cream is taken off, the milk may be drawn at once into the vacuum-pan, simply by running a rubber hose from the milk to the pan, as the suction produced by the vacuum in the pan is sufficient to draw the milk through the pipes. During the process of condensing, the temperature in the pan is kept at about  $135^{\circ}$ , a vacuum of from 22 to 25 inches being maintained.

The milk having been reduced to its proper consistency, is drawn from the vacuum-pan into the cooling-pails, which are immediately plunged into the vats containing cold spring water. The pails are about half filled, the average temperature of the water being  $52^{\circ}$  Fahr. When thoroughly stirred and cooled it is ready to go into the non-conducting shipping cans to be transported to market. The plain condensed skimmed milk brings 25 cents (one shilling) per quart.

Under this process, in the month of July, when the daily delivery of milk was between 5000 and 6000 quarts, 8 quarts of milk yielded 1 quart of cream, and the whole quantity of cream made 400 lbs. of butter per day.

When whole milk and skim milk are used together for condensing—the evening's milk having been strained and placed in the small tin cooling-pails—they are taken to the water pools or tanks, and are surrounded with flowing spring water on the same plan as at the butter factories.

Here the milk sets until morning, when the pails are taken out, and the cream is dipped off. The skimmed milk is then immediately drawn into the vacuum-pan. In a vacuum of about 24 inches the milk will begin to boil when the mercury indicates  $100^{\circ}$  Fahr. The heat soon rises to  $135^{\circ}$  or  $140^{\circ}$ , and is allowed to go no higher. The morning's milk, as fast as it is delivered, goes to the pools the same as the night's milk, and after the milk in the vacuum-pan has been somewhat reduced in volume, the morning's mess is taken from the pools, and is drawn into the pan, and the mixture then reduced.

By this process it is stated that a tolerably fair product of plain condensed milk can be made; while for sugared milk some operators think a more uniform product, or the "smoothest milk" is made from milk that has had about half its cream removed before going to the pan.

One of the leading difficulties in the condensing process is to carry the milk along, and draw it from the pan before it is in a condition to granulate on cooling. It should be "smooth," and not gritty under the tongue, the latter state arising from the sugar of milk assuming a granulated form. When milk is treated in this way no saltpetre is added, or indeed any other chemical. The use of such substances to clarify the milk is

believed to be of doubtful expediency ; since it is always better to have the milk so clean, and in such good order, that these clarifying aids may be dispensed with.

Under this latter plan butter factories have been successfully turned into condensing factories at small cost, since a copper vacuum-pan, 4 feet in diameter, with all the fixtures complete, may be had for 1500 dollars, and a single vacuum-pump of suitable size for the pan 800 dollars, or a duplex-pump 1000 dollars, making for the pan and pump either 2300 dollars or 2500 dollars (500*l.*)

From the foregoing statistics it appears that 15 quarts of milk are required for 1 lb. of butter, while a pound of butter is made on an average from less than 2 quarts of cream. In 1871, the butter was marketed at 40 cents per lb., and the butter-milk at 1 cent per quart. There were 750 quarts of cream taken from the 6000 quarts of milk, which would leave 5250 quarts skimmed, and this, deprived of 75 per cent. of water, makes 1312 quarts of plain condensed milk.

Without taking any account of the butter-milk, the daily receipts may be very nearly estimated as follows :—

400 lbs. butter at 40 cents per pound .. .. .	dolls. 160·00
1312 qrts. condensed skimmed milk at 25 cents per quart ..	328·00
Total .. .. .	
Deduct cost of 80 galls. crude milk allowed for waste at 12½ cents per gallon .. .. .	10·00
(95 <i>l.</i> 12 <i>s.</i> ) . . . . .	
	478·00

The daily expenses on the basis of former estimates would be as follows :—

6000 qrts. of milk, or 1500 galls., at 12½ cents per gallon ..	dolls. 187·50
Daily working expenses of the factory .. .. .	24·50
(42 <i>l.</i> 8 <i>s.</i> ) . . . . .	
Leaving a daily balance of 266·00 dolls. (53 <i>l.</i> 4 <i>s.</i> ) above expenses.	

Perhaps it may be said that my estimate of factory buildings in the first instance (2500 dollars) is too low. This is a matter which cannot well be regulated here, but the other expenses it is believed are pretty near the mark, and will give sufficient data for determining the profits to be derived from the business.

Providing one half of the skimmed milk be made into skimmed cheese, we should have as before :

	dolls.
400 lbs. of butter at 40 cents per pound .. .. .	160·00
656 qrts. of condensed milk at 25 cents per quart .. ..	164·00
2625 qrts. of milk, or, say 5250 lbs., making 525 lbs. of skim cheese, at 10 cents per pound .. .. .	52·50
	<hr/>
	376·50
Less 80 galls. for waste .. .. .	10·00
	<hr/>
	366·50
The daily expenses as before, 6000 qrts. milk at $3\frac{1}{8}$ cents per quart .. .. .	187·50
Working expenses of factory .. .. .	24·50
	<hr/>
	212·00
	<hr/>
	154·50

Leaving a daily balance above expenses, when butter, cheese, and plain condensed milk are made, of 154 dollars, 50 cents (nearly 31%).

It will be seen that the profits from the business must vary considerably according to the character of the manufactured product; and under the combined factory plan here described, great latitude is given to vary the manufacture of the milk into such products as may seem most advisable from time to time.

It may also be observed that when milk is set for cream during eight to twelve hours only, and is then skimmed, the skimmed milk retains a considerable quantity of butter, and makes a rich tasting and highly palatable article of condensed milk; since by varying the quantity of water for the purpose of returning it to its original consistency, or by using less water, it can be made to assume the appearance of cream, while it contains more albuminous constituents, bulk for bulk, than the milk in which all the cream is retained. For invalids or those in delicate health the skimmed milk is on some accounts preferable, and is so recommended by physicians.

#### MARKETING.

The question of markets and marketing is perhaps the most serious of any concerning this business. I have given the prices at which the different kinds of condensed milk are sold. But can these prices be maintained? and is there a demand and a market for any considerable increase in these products? These are grave questions, and of serious importance to those who are proposing to embark upon condensed milk manufacture.

So far prices have been maintained, and the Borden factories have met with abundant success. I do not hear of any complaint among consumers that prices are exorbitant, but, on the contrary,

many affirm that condensed milk is cheaper than the milkman's crude milk, inasmuch as the latter is largely adulterated with water, and is liable to sour on your hands; besides, from its frequent imperfections losses are entailed upon the consumer which amount to more, during the course of a year, than the difference in price between crude and condensed milk. City consumers who have been accustomed to the use of condensed milk, generally prefer it to the crude milk, as more uniform in quality, more convenient for use, more reliable in flavour, and more healthful as an article of food. But the class using condensed milk in America, as compared with that using crude milk, is very small. Indeed there are thousands of people who have never tasted or even seen or heard of condensed milk.

Doubtless, if the public generally could be made acquainted with the cleanliness required, and the freedom from impurities or adulterations in condensed milk, it would soon take the place of crude milk in all our leading towns and cities. Immense sums are now expended in carrying the crude milk to market, 75 per cent. of which would be at once saved, if condensed milk could be made to take the place of crude milk.

But should the water with which the milkman dilutes his milk be also taken into account, the saving on transportation would be much greater.

Up to the present time the condensing business has been in a few hands, and, as little has been known generally concerning the manufacture or its profits, prices have been controlled and maintained. Is it not to be feared that any large and sudden increase in condensing milk (especially before people have become somewhat educated as to its use and character) would have a tendency to glut the market, and thus prove disastrous to manufacturers? With an increased manufacture there is little probability that present prices can be maintained; and here the question occurs, whether a considerable reduction in rates could not be made and yet a fair profit realized in the business.

The price of crude milk in all our large cities will average nearly, if not quite, 8 cents per quart. Say that 1 cent ( $\frac{1}{2}d.$ ) per quart be allowed the factory for manufacturing the plain condensed milk, and 4 cents ( $2d.$ ) per quart as the cost of crude milk at the factory, then there are 3 cents ( $1\frac{1}{2}d.$ ) per quart which remain to be expended in transportation and delivering it to city consumers. Upon this basis 4 quarts of crude milk, reduced to one quart condensed milk, would be worth 20 cents ( $10d.$ ) at the factory.

This would give a living profit to manufacturers and producers. And now the question occurs, how much is it worth to transport and market the quart of condensed milk. Call it 4 cents ( $2d.$ ), and we have the quart of condensed milk in the hands

of consumers at 24 cents (1s.), which is equivalent to crude milk at 6 cents (3d.) per quart. But as the condensed milk is cleaner, purer, and will remain sweet and sound longer than the crude milk, the consumer realizes the boon long sought for in obtaining a cheap, nutritious, and healthful food.

In the higher and more philanthropic aspect of life, the cheapening of food for the masses, and especially for the agricultural labourer and the poor, is a consideration not to be overlooked.

Looking at this question of markets in all its relations, I should say that the safest plan to be adopted would be to establish combined factories, where the main business at first would be the manufacture of cheese or butter, or both, entering upon condensed milk gradually, and making no more than could be marketed in the nearest cities and surrounding towns. I have no doubt that in every country village where crude milk is peddled, plain condensed milk could be readily introduced; and if a uniformly good article were furnished at reasonable rates, I am of the opinion that it would supplant in a great measure the crude milk.

I cannot tell how long it may take to introduce this form of milk into general consumption; that must depend in a great degree upon the activity and energy with which it is placed before the public. People are wedded to old usages, and do not readily change unless urged or convinced of the advantages resulting from such change. But I am persuaded that the manufacture of condensed milk, like other practical methods for improving the comforts and healthfulness of mankind, must in the end be triumphant. City consumers have for years endured the bad milk brought to their doors as a necessary nuisance, from which there was no ready way of escape. The new method opens the remedy for this difficulty, and as people become acquainted with it, we may reasonably suppose that they will adopt it.

#### BUTTER-MAKING AT MILK-CONDENSING FACTORIES.

It will be seen from what I have said that butter-making will naturally be connected with the condensing process. In last year's volume of this Journal\* I gave a pretty full account of the American butter-factory system; but some improvements, brought out during the past year, have been found so useful, that they deserve a passing notice in connection with this paper.

In butter-making, as in almost every other kind of work, labour is lessened, and the object accomplished with much more

\* 2nd Series, vol. vii., part 1, No. xiii., p. 1.



facility and satisfaction, by having proper appliances, and in knowing how to use them. One of these little appliances is the "Mote skimmer," for taking off specks, flies, or any small particle of dirt that happens to fall upon the milk after it has been strained either into the can or vat. This skimmer is a small tin cup, the inner surface being concave and free from sharp angles. In the bottom is placed a fine wire strainer, about 1 inch in diameter. It is provided with an upright handle some 2 feet in length, thus making an implement much more convenient for removing any little mote from the milk than the common skimmer. The annexed cut (Fig. 15) represents the form of the "mote skimmer."

Fig. 15.—*The Mote Skimmer.*



From experiments with different kinds of churns, American butter-makers are decidedly of opinion that for quantity and quality of product from a given quantity of cream, the dash churn is to be preferred, and most especially is this form of churn to be recommended for butter factories. In this opinion the butter-makers of Orange County pretty generally agree; and as the old-fashioned dash churn is not a patented article, its recommendations to favour must rest upon its merits alone.

For milk-condensing factories the "two-barrel size" is preferred; and the churns should be made with as little bilge as possible. During the churning it is thought desirable to keep the cream from rising above  $60^{\circ}$  in temperature. When the churns are started, the temperature of the cream should be about  $56^{\circ}$ ; and it has been found that the best results are obtained when the dashers make from 40 to 42 strokes per minute. At this rate of stroke, and no less than one hour being consumed in the process of churning, if the temperature of the cream be kept below  $60^{\circ}$ , or no higher than that, the butter will come of good colour and texture, and will be in the right condition for a first-class "fancy product," at least so far as it can be made by the operation of churning. It is important, of course, that the cream be in the proper condition when it goes to the churn; but the manner in which the churning is conducted has a much greater influence upon the product than many people imagine.

The agitation of the cream over the whole mass should be as even and uniform as possible, in order that all the cream may be turned into butter at about the same time. If the agitation is too rapid, or if it be unevenly distributed through the mass, a part of the cream will come to butter while a part will remain

unchanged, and by the time the whole mass is churned, the particles of butter first formed will have been beaten up in the agitation, so as to injure the texture; or portions of unchurned cream may become mingled with the butter, thereby not only lessening the quantity of butter from a given quantity of cream, but materially injuring its quality. Again, in order to preserve a nice flavour and colour, as well as fine texture, the mass of cream while churning must not be allowed to rise to a high temperature.\*

It will be seen, then, to regulate all these points, the proper construction of the churn-dasher is important. Numerous experiments have been made with differently formed dashers, and finally a form has been hit upon that gives much better results than any dasher heretofore used. I give an illustration (Fig. 16) of the dasher, and its proportions as adapted to the "two-barrel churn." The two pieces *a a* forming the dash are 20 inches long by 6 inches broad. They are halved together in the centre, so as to form a cross, the handle of the dasher going through both pieces at *b*. The holes *cc* are made by boring with a  $1\frac{7}{8}$  inch bit into the arms, but not quite through. Then in the centre of this cavity a  $\frac{5}{8}$  inch hole is cut through the arm. The holes *d d* are made in the same way, and a slot connecting the two is cut partly through the timber, in the centre of which a narrow slot goes entirely through the arm. This forms the lower side of the dash, the upper side being shown in Fig. 17.

Fig. 16.—The improved Churn-Dasher (lower side).

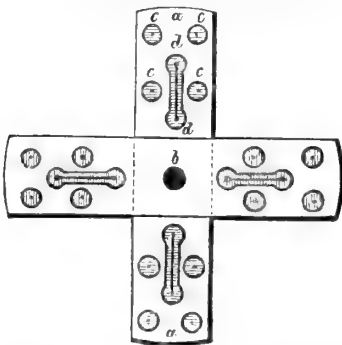
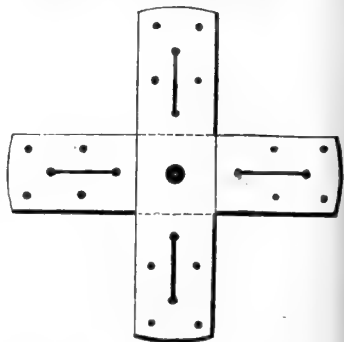

Fig. 17.—The improved Churn-Dasher (upper side).



In a recent tour among the butter factories, I saw the churns in operation with the improved dasher, and with other shaped dashers; all were worked at the same time, and with the same power, and it was plainly evident that the improved dasher did the best work, while the temperature of the cream, which we

tested from time to time, was more even and lower than in the other churns. In some districts the large dash churn is constructed with a hoop at the top to receive the churn cover. This causes considerable trouble in cleansing, as particles of cream and milk are liable to work down between the hoop and staves, thereby becoming foul, unless extra care and labour be taken in cleansing. In the Orange County factories a part of the staves are cut away to receive the churn cover, thus doing away with the cumbersome hoops, and rendering the churn neater in appearance, and more easily cleaned.

In washing the butter another little device is used, which appeared to me to be a decided improvement over the old method. The batch of butter, or the "churning," say of about twenty to twenty-five pounds in weight, is laid upon the butter-worker, and water applied from a sprinkler or small watering-pot. It is provided with a rose nozzle so as to distribute the water over the mass in numberless small streams. The watering-pot is held with the left hand, and the butter worked with the right hand at the same time, by applying the lever, going rapidly over from one side of the mass to the other.

The butter being on the inclined slab or bed-piece of the butter-worker, the butter-milk flows off readily, and by a few movements of the lever the butter-milk is expelled. When the water flows from the mass without being discoloured the process of washing is completed. The cut (Fig. 18) illustrates the sprinkler, and it should be of small size or no larger than can be conveniently handled with the left hand in the manner above described.

Fig. 18.—*The Butter-Sprinkler.*

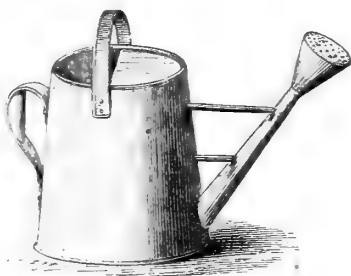

The water, falling in a spray over the whole surface of the butter, cools it and gives the proper degree of hardness for working with the lever, a point of considerable importance, especially in hot weather. When the butter-milk has been expelled, the butter is ready for salting, and the butter-worker is used for incorporating the salt evenly through the mass.

Considerable discussion has recently arisen about the use of saltpetre in butter, some holding that it cannot be healthful even though employed in small quantities, that it adds nothing to the flavour or quality of the butter, that it has no preserving properties, and hence should be banished from the dairy by all good butter-makers. Without entering upon an elaborate dis-

cussion of this question, it will suffice perhaps to say that all the "hue and cry" against the judicious use of saltpetre as a preserving agent for meats and for butter, is, in my opinion, not well-founded, and is creating needless alarm in the minds of many; indeed, I believe the evils complained of from its use are more imaginary than real. Saltpetre has been used from time immemorial in curing meat, and of the thousands who thus annually employ it I have yet to hear of a single well-authenticated case where it has proved injurious.

Doubtless saltpetre may be used in quantities hurtful to health, but so may common salt, or pepper, or sugar, or tea, as well as many other articles of food generally considered harmless.

Now, the butter-makers of Orange County claim that, by the use of saltpetre, butter will retain its flavour, and keep sound longer in hot weather than when it is not used. They say that many direct experiments have been made to test this point, and, in every instance, the samples of butter cured with saltpetre kept sweet longer, and were better saved than those samples where it was not used.

For curing butter made in summer the following mixture is used at the Orange County factories, viz.:—For every 22lbs. of butter, 16 ounces of salt, one tea-spoonful of saltpetre, and a table-spoonful of the best powdered white sugar. In preparing this mixture, Ashton salt is crushed under a roller to free it from all lumps; it is then run through a sieve, and the saltpetre, after being reduced to a powder, is evenly mingled with the sugar through the salt. I tested the butter cured with saltpetre at the factories and found it of delicious flavour with that fine texture and colour which would command the highest price in the market.

Small return butter pails, similar in construction to Westcott's "Return Pail," and each holding five pounds, have been used in sending the butter to market. These little packages, or tubs, are provided with a cover which fastens with a clasp. They are very neatly made of oak, and hooped with brass, which gives them an exceedingly handsome appearance. They are, when filled, packed in cases, twelve packages in a case, in two tiers one above another. A board is placed between the upper and lower tiers.

The cuts (Figs. 19 and 20) represent the packages and the manner of packing.

There is a cleat running round the box on the inside, about the height of the packages, so that when the first six packages are arranged in place the division-board goes down upon the cleat covering the lower packages, and upon this board the upper tier of packages is placed. The lid of the case is then

brought down and fastened with a clasp, and the packages go safely to market without shaking or moving. The butter in each

Fig. 20.—A Case with packages arranged for market.

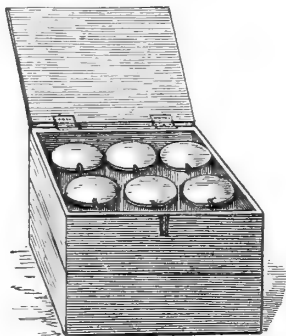

Fig. 19.—The Five-pound Butter-package.



package is stamped with a mould, so as to leave the imprint of the maker's name under a rose.

The most approved method of packing butter for the winter market is to pack in oak tubs or firkins, so that it will keep sound and sweet. The firkin should be made in the best manner, strongly hooped, so as not to admit the least leakage. The Westcott oak pail is one of the best kind of packages. After the tub or firkin has been filled, say within an inch or two of the top, a cloth is placed over it, and a layer of salt put on, or it is covered with brine, so as to exclude the air as much as possible, and kept in a clean, cool, well-ventilated cellar until ready for market.

Recently, Mr. Charles H. White of White Station, Michigan, has invented a method for keeping butter sweet for long periods, which proves to be excellent, and worthy of general adoption. His plan is to have tight and strongly hooped tubs of oak, with heads at both ends. The tubs are 14 inches in diameter at top and 9 inches at bottom, and about 16 inches high. Fig. 21 will illustrate its general form. A sack of white cotton is made to fit the tub for the reception of the butter. It is placed in the tub as it stands on the small end (Fig. 21), the sides of the sack being long enough to extend over the top of the tub.

The butter is packed firmly in this sack until within an inch and three-eighths of the top of the tub, when a circular piece of cloth is laid on the top of the butter, and the sides of the sack are brought over and nicely plaited down over the circular cover. A layer of fine salt is now laid on the top, the head is put in, and the hoops are driven so as to make a perfectly tight fit that

will admit of no leakage. The tub is then turned upon the large head and the butter in the sack drops down upon the larger end,

Fig. 21.—*Package for keeping Butter for long periods.*

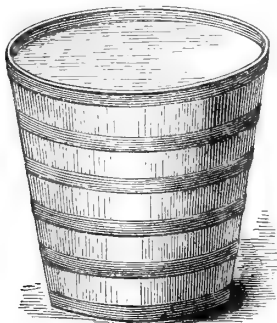
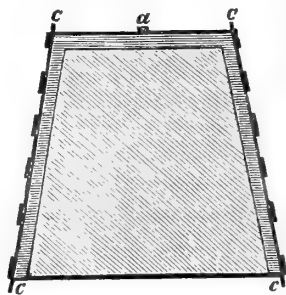

Fig. 22.—*Section of Package for keeping Butter for long periods.*



leaving a space between it and the sides and top of the tub, as will be seen by Fig. 22, representing a section of the tub filled with butter and standing on the large end. Strong brine is then poured into the tub at *a*, till it fills the intervening space *c c c c* between the tub and the butter, when the hole is closed perfectly tight with a cork. The brine floats the butter, so that it is completely surrounded with the liquid, and thus it is effectually excluded from the air. Butter packed in this way, and placed in a cool, clean, well-ventilated cellar, will keep sweet and sound for long periods, and will go to market in prime condition.

When the butter is to be used the tub is turned on the small end, the hoops are started, and the large head is taken off, when the butter may be lifted entirely out of the tub by taking hold of the ends of the sack. It may be placed upon a platter or large earthen dish, the cloth removed from the top, and the butter cut in desirable shapes for the table or for sale. If any portion remains or is not wanted for immediate use, it may be returned to the tub, and in this way it can be preserved for future use.

The plan is a novel one for keeping butter sweet and sound, and I am informed that it has met with entire success. The package holds about fifty pounds. Mr. White has a very ingenious way for cutting the patterns to make the sacks, whereby there is no waste of cloth, and the seams are rapidly run up by a sewing-machine.

When the butter is required for use, by taking hold of the sack by the sides, lifting it from the tub, and turning it down, the butter may be cut in handsome shape to come upon the table, which cannot be done in the ordinary way of packing, as the butter must then be dug out in small particles or cut in untidy pieces.

Butter for the winter market is often packed in firkins holding from 60 to 80 lbs. The firkins are made strong and tight, are provided with heads, and when filled are headed up and brine poured through a hole in the top head, so as to fill all intervening spaces. In packing butter for market, it is important to have a neat and well-made package. If due attention has been given to the manufacture and to the packages, and if the butter has been preserved sweet and sound, there will be no trouble in marketing it at a good price.

It is sometimes desirable to keep milk overnight in good order, and to prevent, as far as possible, the cream from rising. This is usually effected by placing the milk in the cheese-vat and allowing cold spring water to flow in the space between the tin and wooden vats; and at the same time to use an "agitator" in the milk, which is worked during the night by the waste water flowing from the vats. Fig. 23 shows a common cheese-vat, with the agitator attached, and the water-box in front, which supplies the power for working, &c.

Fig. 23.—Milk-Vat, with Agitator arranged for stirring the Milk during the night.

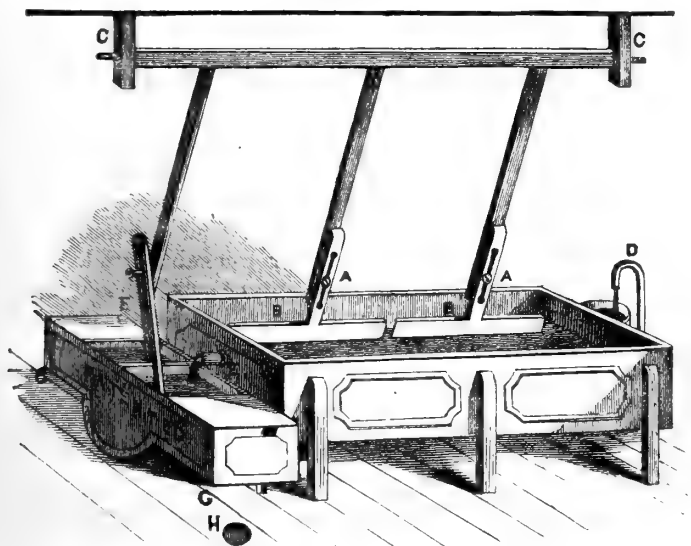

- A, A. Shafts.
- B, B. Floats for agitating the Milk.
- C, C. Connecting-beam.
- D. Inlet Water.

- E. Exit for Waste Water.
- F. Shaft attached to Water-box.
- G. Outlet from one side of Water-box.
- H. Sink for escape of Waste Water.

This box has a partition in the centre, and is provided with a circular bottom, and a discharge-orifice in each division. The

waste water from the vat flows in one division, and here accumulates until there is sufficient weight to carry the box down. This moves the float across the milk. Then, while the water is being discharged, the waste water from the vat is pouring into the other side of the box sufficient to carry that side down, and the float in the milk moves back; and thus the float, moving backwards and forwards at intervals, stirs the milk during the night and prevents the cream from rising. It is a very simple and useful appliance, and does efficient service in exposing the particles of milk to the atmosphere, and thus assists in keeping the milk in good order.

#### CONCLUSION.

In conclusion, I may say that the condensing business requires considerable capital, great labour, unceasing care, and minute attention to details which paid workmen will neglect, if not constantly watched. Mr. Borden thought he could get an extension of his patent if he tried, but he would not try. He preferred to rely on his skill and faithfulness in the manufacture in open competition.

The product made at his factories has never been excelled. In his early experiments scientific men told him that it was useless to think of retaining the (oil) cream; but he said it would not be milk then, only "skim milk," and so he kept on experimenting, and finally succeeded in retaining all the cream. To do this successfully under his process, the milk is brought to a temperature of 212° Fahr. before it goes to the pan, as I have described in the early part of this paper. Some think that the condensing business must necessarily make slow progress, on account of the difficulty of getting skilled labour, and the constant watchfulness required to make an unexceptionable article. Factories have been started from time to time, and abandoned on this account. Mr. Borden has kept steadily on, and has met with merited success, because he has never allowed a poor article to go upon the market. And this should be a rule among all those who propose to enter upon its manufacture.

---

#### IV.—*On the Management of Grass Land, with especial Reference to the Production of Meat.* By H. S. THOMPSON, of Kirby Hall, York.

THE Journal for 1858 contained several articles on the Management of Grass Land, in one of which I gave an account of some experiments in laying down land to grass, and its subsequent management. These experiments have been repeated, under a considerable variety of circumstances, during the last fourteen



years, and as this additional experience has, to some extent, modified my previous opinions, as well as furnished me with additional information, I am induced to revert to the subject now that the production of meat has assumed a degree of importance which cannot be fully appreciated without a brief reference to some of the public documents bearing on the subject.

Since the date of the above-mentioned paper the number of mouths to be fed in Great Britain and Ireland has increased by more than three millions. A mere statement, however, of the increase of numbers, very inadequately expresses the whole additional call for animal food, the rapid development of the industrial resources of the country which has taken place of late having created a demand for labour at advancing wages, which has given the working classes unexampled command over the comforts of life, and greatly increased the frequency of their visits to the butcher's shop.

No reasonable doubt can, therefore, be entertained that the effective demand for fresh meat has risen rapidly during the last few years, and the next questions that suggest themselves are:—Have the supplies kept pace with the demand? And are they still increasing at such a rate as to satisfy the quarter of a million hungry souls which each successive year adds to the population of these islands? I will first deal with the supplies from abroad, and the accompanying Table (A) shows the number of cattle, sheep, and swine imported into the United Kingdom in the years 1863-1871 inclusive, being a continuation of a return published in vol. xxv. p. 29 of the Society's Journal.

TABLE A.

CATTLE, SHEEP, AND SWINE, imported into the United Kingdom during the years 1863 to 1871.

YEAR.	Cattle of all ages.	Sheep and Lambs.	Swine.
1863	150,898	430,788	27,137
1864	231,733	496,243	85,362
Cattle Plague broke out in June, 1865	204,867	914,170	132,943
Cattle Plague ended with the year 1866	237,739	970,580	73,873
1867	177,948	539,716	48,079
1868	136,688	341,155	33,721
1869	220,190	709,843	69,067
1870	202,172	669,905	95,624
1871	248,911	916,799	85,622
	1,811,146	5,989,499	651,428
Average of 9 years .. .. .	201,238	665,499	72,381
Average of 3 years, 1869, 1870, and 1871	223,757	765,515	83,437

It thus appears that, though the foreign supply varies con-

siderably in different years, it has never—even in the year of the Cattle Plague (1866)—reached a point at which it could materially affect the supply of meat for the million. It is satisfactory to find that the recent sanitary regulations, limiting the landing and removal of foreign cattle, sheep, and swine, have not diminished the importations; the average numbers of each kind of stock imported in the three last years—1869, 1870, 1871—having materially exceeded the average of the whole nine years recorded in the Table.

We have next to consider our home resources, in which we are greatly assisted by the returns annually published by the Board of Trade. Unfortunately these returns were not, until 1867, sufficiently complete to be used as a basis for calculation. Table (B) gives the numbers of the live stock in the United Kingdom from 1867 to 1871; and by comparing tables (A) and (B) we learn the very small proportion which the imported flocks and herds bear to the *natives*. Even in 1871, when the prices of beef and mutton, and the numbers of the live stock brought into our ports, reached higher figures than ever before known, the number of cattle imported was only 2·66 per cent. of the home stock, the sheep 2·91 per cent., and the swine 2·07 per cent.

TABLE B.

NUMBER of CATTLE, SHEEP, and PIGS in the United Kingdom, in each year from 1867 to 1871 inclusive, showing the increase or decrease from year to year.

YEARS.	Cattle.	Increase or Decrease from previous year.	Sheep.	Increase or Decrease from previous year.	Swine.	Increase or Decrease from previous year.
1867	8,731,473	..	33,817,951	..	4,221,100	..
1868	9,033,416	+ 351,943	35,607,812	+1,789,861	3,189,167	- 1,031,
1869	9,078,282	- 5,134	34,250,272	-1,356,540	3,028,394	- 160,
1870	9,235,052	+ 156,770	32,786,783	-1,463,489	3,650,730	+ 622,
1871	9,347,789	+ 112,737	31,416,829	-1,369,954	4,136,903	+ 486,
Between 1867 and 1871.	Increase of Cattle	} = 616,316	Decrease of Sheep	} = 2,401,122	Decrease of Swine	} = 84,197

Taking the average of the five years given in Table (B), the imported cattle, sheep, and swine bore to the home-breds the proportions of 2·17 per cent., 1·89 per cent., and 1·82 per cent., respectively. If, therefore, by imposing moderate restrictions on the movement of our flocks and herds, both home and foreign, we can check the spread of disease sufficiently to save the lives of 2 per cent. of our sheep and cattle, we shall add to their numbers an amount equal to the whole of our foreign supply.

I will now endeavour to form an estimate of the amount of beef, mutton, and pork, which the animals recorded in Tables (A) and (B) may be expected to send annually to market. This calculation must, to a great extent, rest on estimate, and cannot approach in accuracy to an ascertained fact; but I have before me so considerable a number of opinions, supplied by some of the most eminent cattle salesmen in the metropolitan and several of the leading provincial markets, also by local cattle dealers and butchers, together with returns from some of the railway companies, who convey large quantities of meat weekly from all parts of the United Kingdom to London, that the figures founded on a careful comparison of these data can scarcely be very far from the truth. Beginning with Table (A), I estimate the weight of the foreign cattle brought to market for slaughter—exclusive of calves, young bulls, &c.—at 620 lbs. per head. A considerable deduction must be made for the number of calves, which, in 1871, were 40,189 = 16·12 per cent. of the cattle of all ages imported in that year. Taking the calves at 80 lbs. each; 16 per cent. at 80 lbs., and 84 per cent. at 620 lbs., give an average of 530 lbs. per head for cattle of all ages. There are, however, a certain number of young bulls and inferior cattle imported for which allowance must be made, and I therefore take the average weight of foreign cattle of all ages at 520 lbs. per head. In estimating the weight of meat derived from this source, it is, no doubt, overrating it to assume that the foreign cattle yield 520 lbs. of meat each as imported, many being milch cows, or store cattle for grazing; but, as there are no data for calculating their numbers or weights, I have preferred to assume that the whole are intended for immediate slaughter. The number imported in 1871 was the highest ever known, viz., 248,911. At 520 lbs. each, this would produce 57,783 tons of beef.

Foreign sheep and lambs I estimate at 50 lbs. per head: the 916,799 imported in 1871 would, therefore, produce 20,464 tons of mutton.

Foreign swine I estimate at 100 lbs. per head, and at this rate the 85,622 swine imported in 1871 would yield 3331 tons of pork; so that the cattle, sheep, and swine, of all ages imported in 1871 would yield 81,578 tons of meat.

The next step will be to estimate the average supply of meat derived from the cattle, sheep, and swine shown in Table (B). For this purpose the United Kingdom may be treated as one gigantic farm, breeding, rearing, and fattening its own live stock; and the proportion of cattle, sheep, and swine sent to market may be approximately estimated by ascertaining how many head of each sort a farm maintaining a herd of 100 cows,

100 breeding ewes, and 20 sows can supply annually for sale. The stock must be self-sustaining, and must, therefore, contain animals of both sexes and of various ages. The following calculation proceeds on the assumption that 100 cows will produce annually 80 calves; that 10 per cent. of these will be killed for veal, and that, apart from any abnormal attack of disease, 3 per cent. will adequately represent the deaths.

SELF-MAINTAINING HERD OF 100 COWS.

<i>Total Herd.</i>		
Cows .. .. .	100	It is assumed that 100 cows will produce 80 calves annually, of which 8 (=10 per cent.) will be killed as veal. To maintain the herd, 20 cows and 1 bull must be supplied annually from the young stock between 2 and 3 years old, thus reducing the number available for market from 72 to 51.
Bulls .. .. .	2	
Young Stock—		
Under 12 months old .. ..	80	
1 year old and under 2 years	72	
2 years old and under 3 } years .. .. .	72	
	326	
Deaths=3 per cent. .. .. .	10	
	316	

*Number available for Market.*

Draught cows and bull .. .. .	21
Calves .. .. .	8
Young stock, 2 to 3 years old .. .. .	51
	80
Less deaths 3 per cent. .. .. .	2
	78

On these data a herd of 316 cattle of all ages will send to market annually 78 head = 24.68 per cent. In applying these figures to Table (B) allowance must be made for the calves not officially enumerated. Calves for veal are nearly always killed under eight weeks of age, and as the enumeration is only made once a year, and the consumption of veal is tolerably uniform through the year,  $\frac{5}{6}$ ths of the veal calves are born and die without finding their way into the annual return. In the foregoing statement a herd of 326 animals contained 8 veal calves, and of these  $\frac{5}{6}$ ths (= 6 $\frac{2}{3}$ ), which is equal to 2 per cent. of the whole herd, would be omitted from the official return. Two per cent. must therefore be added to the number of cattle in that return, which would have the same result (within a very minute fraction) as raising the percentage given above of cattle available for slaughter from 24.68 to 25 per cent. It will therefore be assumed that 25 per cent. of the cattle of all ages in Table (B) will be annually available for slaughter.

A similar calculation applied to sheep shows that a self-sustaining flock will send to market 42 per cent. annually, if it be correct to assume that 100 ewes will produce 130 lambs, of which 32 (= 25 per cent.) will be killed under one year old. It is also assumed that, apart from any specific attack of disease, 5 per cent. per annum will represent the deaths.

SELF-MAINTAINING FLOCK OF 100 EWES.

<i>Total Flock.</i>		It is assumed that 100 ewes will produce 130 lambs, of which 32 (= 25 per cent.) will be killed under 1 year old. To maintain the flock, 33 ewes and 1 ram must be supplied annually from the shearing sheep, thus reducing the shearlings available for market from 98 to 64.
Ewes .. .. .	100	
Rams .. .. .	2	
Lambs .. .. .	130	
Shearlings .. .. .	98	
	330	
Deaths = 5 per cent. .. .. .	17	
	313	

*Available for the Butcher.*

Culled ewes and ram .. .. .	34
Lambs .. .. .	32
Shearlings .. .. .	64
	130
Less deaths .. .. .	5*
	125

A flock of sheep numbering 313, of all ages, will thus send to market annually 125, = 40 per cent.

In applying these figures to Table (B), some adjustment must be made to compensate for the great number of lambs killed before the time of taking the agricultural census in June. April, May, and June are the great lamb-consuming months in the large towns, whereas in the country the greatest number are sent to the butcher in June, July, and August. It will probably be fair to assume that half the number destined to be killed as lambs are slaughtered by the middle of June, when the official enumeration is made. In the calculation given above, the lambs slaughtered (32) are about 10 per cent. of the whole flock, and if half of these are omitted from the Government return it would require an addition of 5 per cent. to the number of *sheep and lambs* shown in Table (B), in order to make good the omission. This would have the same effect, so far as our calculation is concerned, as adding 2 per cent. to the numbers

\* There are fewer casualties among the fattening than among the breeding stock.

“available for the butcher.” I shall therefore assume that our home-bred sheep and lambs will send to market annually 42 per cent. of the entire number shown in Table (B).

Few farmers, probably, will find these figures precisely agree with the results of their own breeding and feeding operations, but they must bear in mind that an attempt is here made to strike an average of the productiveness of flocks and herds of different races, placed under the most varying conditions of climate, food, and shelter. One of the most likely points to be questioned is the average rate of increase of a flock of sheep, viz., 130 lambs from 100 ewes. It would no doubt be easy to name districts where the customary increase is much greater. In the flat lands, 150 lambs to 100 ewes is a common occurrence, but the hilly districts of the United Kingdom cover a great extent of country, and 130 lambs to 100 ewes would seem as extravagantly high to a breeder of mountain sheep as it would be thought below the mark by the owner of a sheep farm in the plains, who always provided succulent food for his ewes at the time of admitting the rams. From a number of letters on this subject I have selected two as representing the extreme views on this point. One is from an eminent Northumbrian farmer, who says that in the four years 1868-71, 1280 ewes produced him 2122 lambs, notwithstanding that in one of those years he had the bad luck to have 25 barren ewes. This is at the rate of 166 lambs per 100 ewes. The other extreme is described in a letter from a friend in Kent, who says, “Kent sheep, as a rule, do not twin much, and we much prefer they should not.” . . . . “I should say that if you were to put it at 105 lambs for 100 ewes, you would be about right as regards my district, though this year I have 400 lambs from my 350 ewes.”

The proportion of pigs annually available for slaughter is far greater than that of either cattle or sheep, as a breeding sow will generally produce two litters per annum, which may be averaged at seven each. The sows themselves are seldom kept more than two years, and the bacon-pigs are killed at one year to one and a half year old—average fifteen months. There are no sufficient data for determining the proportion of porkers to bacon-pigs slaughtered. In the large towns great numbers of pigs are killed for pork, and comparatively few for bacon. In the country districts it is exactly the reverse; every well-to-do labourer kills his bacon-pig, and every farmer his two or three up to eight or ten; but the quantity of fresh pork consumed by either farmers or labourers is comparatively trifling.\* The large production and

\* Bacon-pigs here include all pigs killed for salting; porkers, all consumed fresh. A portion of a pork pig put in to pickle for a short time would not prevent its being included in the latter class.

consumption of bacon in the agricultural districts is an important element in estimating the national supply of meat, and is liable to be underrated in consequence of its never being brought to market, or in any other way exposed to public view. I have had a careful enumeration made of the pigs in the two parishes immediately adjoining my residence, which contained, in 1871, a population of 1139 souls entirely dependent on agriculture for their support. In these two parishes 230 bacon-pigs and 35 porkers have been killed within the last twelve months, the whole for home consumption. The bacon-pigs averaged 306 lbs., and the porkers 86 lbs. each. Of the 230 bacon-pigs, 94 were killed by farmers, 113 by labourers, and 23 by small tradesmen and others not belonging to either of those classes. I have no reason to think that these parishes differ in any material respect from the average agricultural parish of the northern counties. In Ireland the proportion of bacon-pigs to porkers killed is much larger than in England.

From the best information I can obtain I am disposed to fix the proportion of bacon-pigs to porkers for the United Kingdom at two to three. The numbers will therefore stand as follows:—

SELF-MAINTAINING HERD OF PIGS.

<i>Total Number of Herd.</i>							
Sows	..	..	..	..	..	20	} 280
Boar	..	..	..	..	..	1	
Porkers	..	..	..	..	168	} 280	
Bacon-pigs	..	..	..	..	112		
						301	} 280 pigs.
Less deaths = 3 per cent. .. ..						9	
						292	

*Annually available for Market.*

Sows (half)	..	..	..	..	..	..	10
Boar	..	..	..	..	..	..	1
Bacon-pigs ( $\frac{4}{5}$ ths killed yearly)	..	..	..	..	..	..	90
Porkers (all)	..	..	..	..	..	..	168
							269
Less deaths 3 per cent. .. ..						8	} .. 19
To replace breeding stock .. ..						11	
							250

A herd of 292 pigs of all ages, will therefore supply annually for slaughter 250, =  $87\frac{1}{2}$  per cent. This will require considerable modification, in consequence of the number of young pigs

necessarily omitted from the June census. Roasting pigs are seldom more than a month old, so that eleven out of every twelve are born and die after one census day and before the next. Similarly, porkers whose average life does not exceed five months, would more than half of them be unrecorded, even if the consumption of pork were tolerably uniform through the year; but, as the great pork-consuming months are November, December, January, February, and March, I cannot estimate the number omitted at less than  $\frac{3}{5}$ ths of the whole porker class. The pork-pigs are estimated above at 168 out of a herd of 301, = 56 per cent., and of this 56 per cent.  $\frac{3}{5}$ ths are omitted from the census;  $\frac{3}{5} \times 56 = 33$ . It will therefore be necessary to add 33 per cent. to the number of pigs in the Government return. It has been already shown that  $87\frac{1}{2}$  per cent. of our whole stock of pigs are slaughtered annually, and  $87\frac{1}{2}$  per cent. of the number of pigs in the Government return, with 33 per cent. added, is equivalent to rather more than 116 per cent. of the number as it originally stood. Hence it appears that the number of home-bred pigs annually slaughtered in the United Kingdom amounts to about one-sixth more than the whole number recorded in Table (B).

Up to this point the calculation has been confined to determining the *numbers* of the different kinds of home-bred livestock annually slaughtered, and these have been fixed at 25 per cent. for cattle, 42 per cent. for sheep, and 116 per cent. for pigs, of the number given in Table (B). The next step must be to ascertain their respective weights. The average weight of home-bred cattle, of all ages, I fix at 600 lbs. per head. This is below the weight given me by the leading salesmen, but I am disposed to think that the great dealers who are more conversant with prime animals than with inferior stock, do not attach sufficient importance to the effect the light weights have in pulling down the average, and the railway returns confirm me in this view. I shall therefore proceed on the assumption that the average dead weight of cattle of all ages is 600 lbs.

The average weight of sheep I fix at 72 lbs. per head, and of lambs at 24 lbs. per head. It will be seen by the figures relating to a self-sustaining flock of sheep that there were 98 sheep sent to market for every 32 lambs: 98 at 72 lbs. each, and 32 at 24 lbs. each, give an average of 60 lbs. for the whole. The average weight, therefore, of the sheep and lambs slaughtered will be taken at 60 lbs. each.

The average weight of bacon-pigs I estimate at 250 lbs. each. For many of the northern counties this will be below the mark. The large breed is in high favour among the artisans in the



manufacturing towns and villages, many of whom pride themselves on feeding their pigs up to 700 or even 800 lbs. each. On the other hand, in some of the midland and southern districts there is a tendency to patronize the small short-nosed breeds, which frequently do not exceed 140 to 160 lbs. when killed for bacon. But the fancy breeds, either large or small, exercise comparatively little influence on the average of the whole country. By far the largest portion of the pig stock of the United Kingdom is composed of moderate-sized animals, of which the Berkshire and the Yorkshire pigs may be taken as types of the black and white breeds respectively. The average weight of these, when slaughtered, is about 280 lbs. There are, however, large numbers of pigs killed for salting, especially in the south of Ireland, which fall short of the usual weight of the regular Christmas bacon-pig. In October 1869 I visited one of the large pig-killing establishments in Waterford; and found a goodly row of 700 pigs slaughtered that morning. There were 12,000 carcasses of pigs on the premises, the proceeds of the previous three weeks' operations. The weights of these were from 150 to 250 lbs., and would, I think, scarcely reach an average of 200 lbs. These weights would probably be somewhat increased as the season advanced. On the whole, I think 250 lbs. fairly represents the average weight of a bacon-pig.

I estimate the porkers at 65 lbs. each. The professional opinions all incline in favour of 70 lbs. or more, on the ground that comparatively few are killed below 70, whilst there are a fair number of heavy weights killed even up to 140 lbs. each, not only for consumption as pork, but to be worked up into sausages, and other forced-meat compounds. No doubt this is true as regards the large towns, but in the country districts and small towns a few roasters and a good many young porkers are killed; and as the large breeds are unsuited for early slaughtering, the small breeds are generally selected for the purpose, and only reach light weights. I therefore assume the average weight of porkers killed to be 65 lbs.

It has been already shown that, out of 269 pigs of all ages available for market, 101 would be killed for bacon, and 168 for pork; and applying to these numbers the weights of 250 lbs. and 65 lbs. respectively, we arrive at an average of 134 lbs., which will represent the average weight of home-bred pigs of all ages killed in the United Kingdom.

We are now in a position to apply these numbers and weights to Table (B). Beginning with the year 1871:—25 per cent. of the 9,347,789 cattle recorded in that year = 2,336,947, and multiplying this number by 600 lbs., gives us 625,968 tons of beef and veal as the produce of our cattle last year. Similarly

42 per cent. of the 31,416,829 sheep and lambs recorded = 13,195,068 which, at 60 lbs. each, would yield 353,439 tons of mutton and lamb. And lastly, 4,136,903 pigs, at 116 per cent = 4,798,807, which, multiplied by 134, gives 287,071 tons of pork and bacon. These figures give us a total of

	Tons.	Per cent.
Beef and veal .. .. .	625,968	
Mutton and lamb .. .. .	353,439	
Pork and bacon .. .. .	287,071	
<hr/>		
Produce of meat from homebred flocks and herds in 1871 .. .. .	1,266,478	= 87·51
Produce of meat from imported flocks and herds in 1871 (see p. 155) .. .. .	81,578	= 5·64
Imported provisions, fresh, salted, or otherwise preserved (see Board of Trade returns for 1871) .. .. .	99,125	= 6·85
<hr/>		
Total supply of meat, home and foreign, in 1871	1,447,181	100

The same calculation applied to the returns for 1870 shows that 1,240,603 tons of meat were supplied by our home-bred cattle, sheep, and pigs, in that year. Similarly the imported animals in 1870 furnished 66,556 tons, and the imported provisions of all sorts—fresh, salted, and otherwise preserved—57,743 tons.

	1870.	1871.	Increase.	Proportion of Increase.
	Tons.	Tons.	Tons.	
From Homebred Animals	1,240,603	1,266,478	25,875	= 31·44
,, Imported Animals	66,556	81,578	15,022	= 18·27
,, Imported Provisions	57,743	99,125	41,382	= 50·29
	1,364,902	1,447,181	82,279	100

Comparing these with the figures for 1871, we find that, in the latter year, there was an increase in the supply of meat from all sources of 82,279 tons, of which nearly one-half was in the form of salted or preserved meat, the quantity of fresh meat imported being small. It also appears that, even under the stimulus of extraordinarily high prices, there was little elasticity in the import trade, so far as live animals were concerned; the importations in 1871 being very little in excess of those in 1866, when there were 11,172 head of cattle and 11,749 pigs less, but 54,081 more sheep imported than in the first-named year.

An elaborate and very valuable article on this subject appeared in the 'Chamber of Agriculture Journal' of May 29, 1871, which, unfortunately, did not come into my hands until after the

foregoing statement respecting our meat-supply was prepared. Had it been otherwise, I should have been spared the labour of collecting the data on which the calculations are founded.

Though differing in many matters of detail from the article in question, the only considerable divergence is in the average weight of the pigs slaughtered in the United Kingdom; and on this point the best-informed opinions differ so widely, that it would have been strange, indeed, if two independent calculations, both founded on estimate, had arrived at any close coincidence.

As regards sheep and cattle, the substantial agreement of the main results obtained by two distinct modes of handling the subject is a strong confirmation of both.

In that article it is shown that during the four years, 1867-71, the annual consumption of meat in the United Kingdom was slightly under 7 stone per head of the population. The rate of increase of the nation is 252,463 per annum, and the supply of meat from all sources has been shown to have been greater by 82,279 tons in 1871 than in 1870. This would be at the rate of 52½ stone for each additional individual, or more than seven times the average consumption; so that the national stock of animal food, if equally divided amongst the population, would, even after filling the 252,463 additional mouths, supply a larger allowance to each individual in 1871 than in 1870. Consequently, meat might have been expected to have been cheaper, whereas, in point of fact, the price of butcher's meat was higher in 1871 than ever before known; showing that the increased demand for meat is not to be measured solely by the increase of population, but that, so long as the country continues to make progress, the increasing ability of the whole nation to buy will require a more rapid increase of supply than even the large additions which have been made in the last few years.

The most probable mode of accomplishing this important object is to improve our grass land. The land under "Permanent Pasture" in the United Kingdom was returned in 1870 at 22,085,295 imperial acres.\* This is exclusive of 31,336,215 acres partly occupied by towns, roads, and inland water, but chiefly consisting of wild moor and mountain, furnishing but scanty herbage, yet, in the aggregate, supplying large numbers of hardy sheep and cattle, to be fattened on better land. The United Kingdom in 1870 contained also 6,320,126 acres of *clover and grass under rotation*. Of these three great divisions of land devoted to the maintenance of live stock, the first is the only one which holds out much promise of speedy improvement, as moors and mountains are costly to improve and precarious in their

\* Agricultural Returns, 1870.

returns; and the clovers and rotation-grasses, being preparatory to the growth of corn, are, for the most part, as well managed as the skill and means of the occupiers permit. I propose, therefore, to limit my suggestions for improvement to the twenty-two millions of permanent pasture above mentioned. The great bulk of this large area is in England and Ireland, as in Scotland grass is generally grown as a rotation crop; so that in 1870 England, Ireland, and Wales, contained 21,098,828\* out of the 22,085,295 acres of permanent pasture in the United Kingdom.

Within the last three years I have endeavoured to ascertain by personal observation the general state of the grass land of the two former countries. In 1869 I spent a few months in visiting every county in Ireland, and in 1870 and 1871 I travelled many hundred miles to make myself acquainted with some of the most famous grazing districts in England. The following are three of the general conclusions at which I arrived:

1st. That although very excellent management is to be met with in parts of our best grazing districts in Leicestershire, Northamptonshire, Gloucestershire, Somersetshire, and several other counties, this must be considered quite exceptional, and the treatment of the bulk of the grass land of the country is very unsatisfactory.

2nd. That our grass lands, if properly managed, would be easily able to meet the demand made upon them for an increased production of meat, even if the supply required were greatly in excess of the present rate of consumption.

3rd. That money judiciously laid out in improving grass land makes a better return than money laid out on arable land.

With reference to the first assertion, though 9s. per stone for beef and mutton is causing considerable stir amongst grass-land farmers, the efforts to improve are very desultory, and entirely without method or system. If corn or roots are to be grown, pains are taken to give a dressing of the most suitable tillage, and to remove the interloping weeds which rob and threaten to smother the crop; and if any tenant tries to grow successive crops without manure, or systematically allows his fields to be red with poppies or yellow with charlock, the neighbours shake their heads, and hint that he is getting near the end of his tether. But if he totally neglects his pastures, never giving himself the trouble to consider whether bad grass might not be improved, or whether the docks and thistles might not be destroyed at very small cost, no surprise is excited, because, unfortunately, improved management is the exception and not the rule. It is, however, not my object to dwell on the defi-

\* Agricultural Returns, 1870.

ciencies of our present practice, but rather to call attention to the great opportunity afforded by the present high prices of meat to improve our grass land and our banker's balances by one and the same operation.

The problem before us is how to improve 22 millions of acres of grass land, so as materially to increase the production of meat and leave a safe profit to the improvers. These 22 millions of acres contain every variety of land, and are placed under an equal variety of management, and the value of the gross annual produce may be said to vary between the extreme limits of 10*l.* and 5*s.* per statute acre. It may be well to define at the outset what is meant by first-rate grass land, that we may have before us a standard of excellence towards which improvers may strive to approach as nearly as circumstances will permit. The rent actually paid is clearly no guide at all. The amount obtainable at annual lettings by public competition approaches much more nearly to the value; but as annual letting is seldom practised, and cannot be recommended except under very exceptional circumstances, I prefer to take as my standard of excellence land which, in a good grazing year, will produce 20 imperial stone of meat per acre without artificial assistance.

Unfortunately the quantity of such land is extremely small, and is for the most part confined to the alluvial flats which have accumulated near the existing or former outlets of some of our tidal rivers. The far-famed pastures along the banks of the Axe the Brue and the Parret, in Somersetshire, are of this character, and constitute probably the most extensive flat of first-rate grass land in the United Kingdom. Here may be seen 1000 acres let annually for grazing by the trustees of one estate, which bring in between 5000*l.* and 6000*l.* per annum. The land is let annually in 54 fields of various sizes, and clear of all rates, taxes, and tithes. In 1870 the 54 lots let for 5948*l.*, and in consequence of the extreme drought of that summer the lettings in 1871 were reduced to 5664*l.*; but it is a striking proof of the intrinsic excellence of the pasture that, after 1870, one of the worst grazing years on record, this estate should still have let in 1871 for 5*l.* 13*s.* 3*d.* per acre!

The residents in the most noted grazing districts are each confident that their own is the best in the kingdom, and I have repeatedly been challenged to express an opinion as to their comparative merits. In the Eastern Counties the district around Boston is believed to be unrivalled in Great Britain, and doubtless amongst the old enclosures in that neighbourhood are to be found fields which, from their depth of soil and the richness of their herbage, are acre for acre as good as any; but when speaking of grazing districts, the great uniformity of character which

prevails over an extensive area in the Bridgwater Level, and the mildness of the western climate, give Somersetshire advantages which are unequalled in any other part of Great Britain.

Next to the alluvial soils the best pastures are to be found on the carboniferous or mountain limestone, and especially on the beds of drift gravel, partly composed of the *débris* of these rocks. In Ireland a considerable portion of the flat country is overlaid by these drifts, which grow sweet wholesome pasture on which either horses, cattle, or sheep thrive well. It is too much the habit in Ireland to plough out the grass at short intervals, but where it has been left undisturbed for a sufficient period, it improves in quantity and quality of produce until it reaches a point very little below the first-class alluvial land already mentioned. This may be seen to advantage in the County Meath, and portions of the adjoining counties. In several counties of England, too, very good grass land is found on the mountain limestone. The valleys of the Dove and Derwent in Derbyshire, and those of the Wharfe and Ribble in the West Riding of Yorkshire, may be especially mentioned; and according to the dictum of Hudibras, that "the worth of a thing is what it will bring," some of this land might claim to be ranked amongst the very first. Probably no higher bid was ever made for land for agricultural purposes than one which was mentioned to me in November 1871, when walking over a ten-acre field in the immediate neighbourhood of the small town of Settle in the West Riding. It formed part of a farm of about 100 acres, which had recently been offered for sale. My informant was cognizant of the fact that a *bonâ fide* offer of 3000*l.* had been made and REFUSED for this field, the vendor being advised that the sale of the remainder of the farm would be prejudiced to a greater extent than even 3000*l.* by the loss of these 10 acres. No reasonable calculation of produce could justify such a price, but its convenient position, and the great advantage of having a field where grass of the best quality was always growing when the thermometer was above freezing-point, made its estimated worth to the owner of an adjoining farm from 7*l.* to 8*l.* per acre.

In many other parts of England first-rate grass land may be found in isolated patches, where accumulations of silt brought down by successive floods have in the course of ages formed alluvial soils of great depth and richness. It may seem a work of supererogation to make suggestions for the improvement of pastures which already produce great results, but the holders of first-class land may learn something by observing the practice of those skillful and experienced graziers who find it worth their while to give such extreme prices for the occupation of land as some of those already quoted. In order to reimburse themselves

it is necessary that every yard of land should be productive, and the greatest care is taken to mow the thistles whilst still young and succulent, in which state they are (when mown) readily eaten by all kinds of stock. Coarse patches of grass, too, are occasionally switched over by the scythe, or, if necessary, an old horse is tethered in the worst places, until they are cropped down sufficiently to be again grazed regularly by the feeding stock. The loss of grass caused by neglecting to mow thistles and other large weeds would never be permitted if farmers would only consider how largely the fertility of the soil is taxed to nourish these intruders, and how cheaply they may be kept down. An old man and a hard-worn scythe, neither of them fit for regular work, will keep a large acreage of grass free from this constant source of loss.

In addition to these preservative measures, something may be done to increase the produce on even the best land. If the question be asked why such and such a field is worth more to the occupier than the adjoining ones, the reply will frequently be that the field in question *grows early and late*, and even the most unobservant are occasionally struck with the brilliant green of some favoured fields, or portions of fields, when all the rest are brown. But a closer inspection will show that even the brown pastures have green patches in them. Wherever the droppings of cattle have fallen in spring the grass is green in autumn, even after a moderate amount of frost and biting winds, showing that it is not the fault of the soil or the climate that the grass is not still fresh and succulent, but that want of condition produces a feeble vitality, easily affected by cold, which stops the growth of the herbage much earlier in the winter than is at all necessary. There are also patches of land in most pastures where the stock do not like the grass, the deficiency in this case not being in bulk but in quality of herbage. Unless this is caused by defective drainage, a dressing of the mixture to be subsequently described will generally restore the quality and cause these neglected parts to be as well eaten as the rest.

I have ventured to define first-class grass land as that which will produce 20 imperial stone of meat per acre without artificial assistance. Next in order must be placed the land which will produce about the same quantity of beef and mutton, with the aid of a moderate allowance of cake or corn. This quality of land may be found to a greater or less extent in almost all parts of the country, with the exception of the *chalk*, the *light sands*, and the *strong clays*. The practice of giving artificial food to cattle at grass is rapidly gaining ground. It is already apparent that 9d. a lb. for beef and mutton will produce a perfect revolution in

the management both of live stock and of grazing land, and the advantages of the improved system are such that it may be safely expected to outlive any reasonable decline in the price of meat. The easiest kind of food to give in the field is linseed or cotton cake. The mixture I prefer to any other is linseed and decorticated cotton-cake in equal quantities. Bean-meal, too, moistened and rolled into balls is easily given and very effective. Many other kinds of feeding-stuffs either singly or in combination, will recommend themselves according to their relative prices in the market. Where mixed linseed and cotton-cake are given, the cost of the mixture at present prices would be about 1s. 4d. per stone; and supposing it to be unnecessary to commence its use during the first ten weeks of the grazing season, whilst the grass is at its best, if 5 lbs. be given daily to each fattening bullock at the commencement of the last ten weeks, increasing the allowance to 6 lbs., and for the last few weeks to 7 lbs. per day, averaging 6 lbs. for the whole ten weeks, the cost of the artificial food would be 40s. per head. If the land will carry a beast per acre, this will add 40s. per acre to the farmer's expenses, and reduce correspondingly the value of the land when compared with that which will fatten the same number of beasts without artificial aid. Hence, if the very best grass land be supposed to be worth a rent of 5l. per acre, the land which requires cake for finishing the beasts ought not to be rented at more than 3l. per acre. These general figures will, of course, require adapting to each individual case to suit the great variety of qualities of land and other modifying circumstances.

One of the advantages of giving cake to finish beasts, which, on the unassisted grass, would come out in October only half beef, is that the grazier is thus enabled to send his beasts to the butcher at full prices, instead of fattening them in the yards at great cost; or, of selling them as store beasts when many others are doing the same, and the markets are crowded and depressed. In cases where farmers occupy land not well suited for the growth of roots, and do not attempt to fatten beasts in the winter, but give cake in the strawyards to improve the manure, and bring out their beasts in spring in a forward state, it often answers well to give cake in the early part of the grazing season, and so push on their cattle as to get them to market in June and July, when beef is the dearest, to be followed by younger beasts to eat up the rough grass in the autumn and early winter. This is excellent practice, as there is no time when cattle make such rapid improvement, and when the expense of tending them is so light, as when they are having cake or corn on a good pasture. The grazier, too, who has fat cattle in June, has the command of the market, and is to a great extent



independent of season, as should the weather be drougthy and his stock heavy, he can at any time lighten his pastures by draughting a few forward beasts for sale.

Another advantage which arises from giving artificial food to grazing cattle, is that the pastures themselves are gradually improved, until land that is only fit for rearing store cattle becomes capable of fattening stock with a moderate amount of help towards the end of the season.

Hitherto I have spoken of good land only, but unfortunately the larger portion of the pasture land of the United Kingdom may be classed either as *moderate* or *inferior*. I will not attempt to describe the various gradations by which land descends from the highest quality to that which requires some acres to keep a yearling steer, and which was once described by a disheartened occupier, as of that kind on which the grass only began to grow on Midsummer Eve, and gave up growing on Midsummer Day. The various shades of land worth from 40s. per acre downwards require very similar measures for their improvement, and, before making any special suggestions respecting them, it is necessary to declare open war against the time-honoured fallacies that pasture land can be profitably occupied by leaving it to itself, and that a farmer consults his own interests by allowing the arable land to rob the grass. Any one who mows his grass without return robs his land quickly, and he who pastures it without return robs it slowly; but the process is sure as well as slow, and when persevered in long enough produces the splendid variety of thistles, ragwort, scabious, and other flowering weeds, very charming to a botanist in July, but extremely disheartening to the hungry cattle, who are doomed to wander amongst them seeking for grass.

Since the days of Jethro Tull, there have been two recognized methods of keeping up the fertility of land, viz., either manuring at short intervals, or thorough disintegration, produced by frequent stirrings of the soil. It cannot be too strongly urged that as grass land is necessarily deprived of the advantage received by arable land from frequent exposure to the atmosphere, it ought to be furnished in some other way with the minerals required to produce good crops of nutritive herbage. The use of artificial manures has given the grass-land farmer complete command over the supply of nitrogen, but a perfect restoration of the mineral ingredients removed by grazing, and still more by mowing, cannot be effected without an occasional application of farmyard manure or of compost, in which farmyard manure holds an important part; so that it would really be better practice, so far as farmyard dung is concerned, to let the grass starve the arable land, than the arable land starve the grass, since

the arable land can receive its mineral supply from other sources, viz., deep cultivation and thorough aeration. The slovenly management of grass land, which a few years ago was general, and is still too common, would never have been seen if the quality of grass could be appraised as easily and certainly as that of corn. But it is notorious that even the most experienced farmers and graziers can only distinguish between good, moderate, and bad; no man living can distinguish by the eye the subtle difference in the quality of the herbage which makes one very good field worth 1*l.* an acre more rent than another very good field, or one bad field worth less than another equally bad-looking field. So long as a grass field grows about the usual quantity of grass, and the cattle eat it, the occupier is too apt to rest content with the good or bad reputation earned by particular fields without any attempt to alter it for the better, or even to ascertain whether it is not gradually getting worse.

In early life I learnt a lesson on this point which I have never forgotten. A neighbouring gentleman mowed about 50 acres of his park annually, and, not being a farmer, he believed that grass was grass, and made equally good hay whether he went to the expense of manuring it or not. He was also remarkably indifferent on the subject of quantity, saying that he kept a fixed number of horses and cows, and if, in a good season, he had a large crop they ate it all, and in a bad season they made it do; so that he stuck to his system as long as he lived, and the land got no manure but what the horses and cows made. I was thoroughly acquainted with this land, and much interested in watching the result. The produce grew gradually less, not year by year, or the owner would have taken alarm; but each drouthy year that came produced a worse crop than the preceding dry season, until I have seen the produce of the 50 acres carried home in 19 cart loads! The quality, too, had fallen off quite as much as the quantity. In one part of the park, where the land was light, one kind of grass (*Avena flavescens*) had taken almost exclusive possession of the land, and neither cattle nor sheep would graze on this portion, except in the most desultory way; a mouthful here and another five yards further on, picked up on the move, showed what they thought of the system, and even the hay was sorted over rather than eaten by the cows, a large portion being deliberately rejected and trodden under foot. This is an instructive instance, showing that the produce of grass land restored to it annually, less the value abstracted from it by the animals fed on it, will not, when continued for a length of time, prevent ordinary grass land from gradual but steady deterioration. It also shows how much more rapidly light land deteriorates than that which is stronger. The park in question, after being mown for many

years, was certainly not worth more to let than 20s. per acre on the lighter, and 30s. on the stronger land ; but after ten years' continuous pasturing, with occasional manurings and top dressings, it became worth 50s. per acre all round.

Having endeavoured to lay it down as an established fact that no grass land will maintain itself unimpaired without the farmer's aid, I will venture to prescribe a mode of treatment which aims higher than mere maintenance.

On first-rate grass land there is comparatively little to be done. Deep alluvial soils contain such store of the elements of plant-growth, and are for the most part so easily penetrated by the roots of the grasses, that many years' successive pasturing seems to produce but little change in the quality of the herbage. But even here there are gradations of goodness. If the occupier carefully scrutinizes his fields in early spring, he will find backward patches, and in early autumn places that turn brown before the rest. These evidently want helping up, and in mid-summer he will generally meet with places more or less avoided by the cattle, when making their regular grazing rounds. In all these cases a slight dressing of the mixture hereafter mentioned may be put on at any time, being perfectly harmless to the cattle if accidentally taken up with their food. No dressing, however, should ever be applied in drouthy weather. Where a piece has grown coarse from not being eaten, it should be switched over with the sycthe, in order that the tillage may quickly reach the roots of the grass. In this way the land may be kept up to its full producing power.

There is in the country a large quantity of grass land, which is not considered feeding-land, but yet will fatten young heifers or small Irish beasts, if the occupier is not in a hurry, and does not put them too thick on the ground. This kind of land is the most inviting to the improver ; and if the occupier cannot screw up his courage to face the whole at once, he should till 10 acres well rather than 20 in a half-and-half way. Let him give a sufficient dressing to change the character of the herbage at once, so that he may have one field at least on which he can finish off his forward beasts. Mr. Lawes, on his experimental grass plots at Rothamsted, first taught the world that on a piece of old pasture, neither very good nor very bad, different kinds of tillage, repeated on the same ground for a few successive years, will produce as many different kinds of crop as there are kinds of tillage used, the character of the plants in the different plots varying as much as the quantity and quality of the produce. It is quite safe to assert that any occupier may, if he pleases, convert his grass into feeding-land ; and though it will not always pay to do so, there are very many thousand acres on which it will pay well

at the present price of meat. If any one wishes to satisfy himself whether what he has done in the way of improvement is in the right direction, and whether he has carried it far enough, let him watch his cattle when grazing. If they take the grass as it comes, heartily and contentedly, merely rejecting foiled portions, so that they are quickly satisfied and lie down to rest, the occupier may be sure that he is on the right tack, and may leave well alone; but if they pick one bit and leave another, take the top off one kind of plant and nibble a few leaves off another, he may be equally sure that the pasture is unpalatable to the cattle, and that without change they will not give a satisfactory account of themselves at the end of the season.

The three worst kinds of pastures are generally supposed to be those on *light sands*, on *strong clay*, and on *black peaty soils*. The light sands I give up to the plough unless in parks or ornamental grounds, where it is important to preserve the turf; ammoniacal dressings will produce a sudden appearance of improvement on light sandy land; but the effect is not lasting, and the dry bent grasses soon re-assume their sway. A mixed top-dressing will, for a time, increase the clovers, but a heavy dressing of compost, containing road-scrappings, or any other tolerably strong soil, is the most permanently useful. Improving pasture on really light sand is, however, one of the most thankless and ceaseless of agricultural operations, and ought to be the next task for Sisyphus, if ever his rolling stone should wear out.

The strong clays are much more promising. Most clay contains an abundant supply of the minerals which make a soil fertile, but they are in a crude state, and require air to make them fit for plant-food. The cracks caused by drought and worm-holes partially effect this, but the mineral supply from clay land that has been long in pasture is not sufficient to support heavy crops, and it should be a fundamental maxim with all clay-land farmers that their grass should never remain long without a dressing of farmyard manure. Even the poorest, worst-made manure, which is little better than straw, is of great value, as it furnishes the requisite minerals, and, though deficient in ammonia, that can be supplied in soot, nitrate of soda, guano, &c. The grass grown on clay is wholesome and nutritive, unless the drainage is defective, or the land has been robbed; and, with a little extra tillage, clay pastures may be made to get moderate-sized beasts fit for market, especially if helped with cake or corn in the latter end of summer. All tillage should be applied to strong-land pastures early in winter. Many weeks are required to wash in the various mineral salts, and, from the retentive character of the soil, there is no fear of their washing out again. All operations on clay land require more time than on lighter

soil. Soluble matters make their way more slowly down, and plants extend their roots with greater difficulty. It is, therefore, a great object to put on farmyard manure, compost, and even mineral applications, soon after the grass is eaten bare in autumn, so as to have the full benefit of the winter rains. The roots of grass are always growing when the thermometer is above freezing-point; and if by means of tillage applied in early winter the roots of the grass strengthen and extend themselves before the growing season arrives, a good foundation is laid for the increased development above ground which is sure to follow. If, on the other hand, the application of tillage be delayed till March or April, and a droughty spring follow, the application loses great part of its effect for that season.

When grass on clay is very unproductive, it sometimes becomes a question whether it would be better to plough it out and relay it. In such a case much ought to depend on whether the form of the land can be much improved by taking it out, whether high ridges require levelling, awkward watercourses filling up, old banks removing, &c. This is landlord's work, and requires both time and money to do it well. Those who set about it deliberately, knowing the difficulty of restoring the fertility of the old ridges after ploughing down, and prepared to go on paying until the object is accomplished, will ultimately reap their reward; but tenant-farmers or landlords who do not mean to do it thoroughly would be wise to confine themselves to making the best of the old turf. If properly drained, it will yield an immediate return for all tillage bestowed upon it; and, on the whole, I incline to the opinion that grass on clay, being let low will generally pay an improving farmer better than any other kind of pasture land.

The third kind of inferior pasture mentioned above is that on black peaty soils. Where the depth of peat is considerable, or where it lies on white or yellow sand, it is very unpromising; but, even in these cases, I have seen instances where nitrate of soda or soot had a striking effect, and made the cattle eat the rough herbage greedily. The varieties of peaty soils are so numerous, and the results of applying tillage differ so widely, that it is generally advisable to try it experimentally in the first instance, putting a heavy dressing of the tillage intended to be used, on a very small portion of land. Where the peat lies upon clay it can always be made good land if the situation is such as to admit of efficient drainage. Should the thickness of peat be inconsiderable, so that the roots of the grass can reach the clay, a dressing of the tillage already mentioned will almost always succeed in making black land very useful for rearing young stock, with which it seems to agree remarkably

well. Should a few acres be contiguous to a feeding pasture on higher land, I have found it answer well to let even fattening cattle have the run of the whole. They highly relish the variety of the herbage thus afforded them, and in dry seasons the black-land pasture will often keep its colour and freshness when the other burns. Should there be three or more feet of peat upon the clay, it answers best to break it up and give the land a substantial dressing of clay before laying it down again, either by throwing it over the land from trenches, as practised in some of the eastern counties, or, if too deep for spade-work, then by carting it from pits. When this expense has been incurred it will probably become doubtful whether to lay it down again to grass, or to keep it under the plough, for which, after claying, it is extremely well suited.

Frequent mention has been made of a mixed top-dressing which has been found to be a valuable application to grass land. It has been gradually arrived at after many trials and modifications, and consists of *nitrogen*, *phosphoric acid*, and *potash*. These substances may be supplied in the form in which they can be most readily and cheaply obtained at the time and place required. The nitrogen may be furnished in guano, soot, nitrate of soda, or in the more specific form of muriate or sulphate of ammonia. The phosphoric acid may be obtained from bones, mineral superphosphate, or some of the poorer guanos. The potash similarly may be applied in the form of kainit, sulphate of potash, &c. The particular substances I am employing this season (1872) are nitrate of soda, mineral superphosphate, and kainit, in the following proportions: 1 cwt. of nitrate of soda, 2 cwt. of mineral superphosphate, and 3 cwt. of kainit per acre for pasture. At present prices this costs about 42s. per acre. For mowing land, where no manure is used, I should add to the above quantities  $\frac{1}{2}$  cwt. of nitrate of soda, making the whole outlay about 50s. per acre. Where land is annually mown a dressing of this manurial value is required every year to prevent deterioration, except in exceptional cases, such as deep alluvial land, waterside meadows subject to flooding, &c. The best practice is, no doubt, to manure mowing land regularly with good farmyard dung; but in the numerous instances in which this cannot be done, the meadow may be maintained in full productiveness by a good manuring once in three or four years, and a dressing of the above mixture in the intermediate seasons. For pastures it is not contended that a dressing of this character is required year by year, but after laying down a field to permanent grass it is absolutely necessary to till hard for three or four years in order to keep it steadily progressive, and when grass land has been long neglected, and

is thoroughly out of condition, one dressing will not suffice. It requires following up for two or three successive years before the traces of long neglect will be completely obliterated.

My first attempt at top-dressing grass was in 1841, on a field of young seeds which showed a want of condition, and I applied a liberal dressing of nitrate of soda in the month of April. This salt had been only recently introduced to the notice of agriculturists, and I watched the result with considerable interest. The field soon assumed a deep green colour, and showed unmistakable signs of vigorous growth. It was stocked with sheep, which, coming from turnips, ate it well; but, to my surprise, they were seized with scour, and did not thrive. I had not then become aware that agricultural products raised by heavy dressings of nitrogenous manure are always of inferior quality, and unwholesome for stock. As this is a point of importance in the management of either grass or arable land, I shall take some pains to establish the fact. When Peruvian guano was first brought to this country, and used freely for the growth of corn and roots, it was not uncommon to meet with instances where its liberal use was followed, in the case of wheat, by a gross broad flagged plant, which produced a large crop of soft dingy straw, and a small yield of lean dark-coloured grain. The cattle disliked the straw and the millers disliked the grain. Nitrate of soda, soot, or any other ammoniacal dressing too freely used, produces a similar result. If too much nitrogen be applied to turnips the result is rapid growth and speedy decay, and stock fed on them do not thrive without a considerable admixture of other food. In 1846 I saw white turnips that had been grown by a heavy dressing of guano without other manure. They were as big as a man's head the first week in August, were rotten at heart by the end of the month, and collapsed altogether by the middle of September. On grass land the effect of heavy nitrogenous dressings may be observed in most pastures at places where the stock are accustomed to congregate for shade or shelter. The dark-coloured coarse grass grown under such circumstances is familiar to every farmer, and it is equally well known to him that cattle refuse to eat such grass, except under the pressure of absolute want. A still more instructive illustration is to be found when heavy rains in July or August follow a period of drought. At such a time fields of clover and young grass, which have carried a heavy stock of sheep for some months, become absolutely poisonous to lambs, and unwholesome for stock of any kind. Even rabbits and hares from an adjoining cover frequently die in numbers from eating the luxuriant herbage which immediately springs up. This is clearly due to the droppings of the sheep both solid and liquid, which have, during the dry weather

accumulated on or near the surface of the land. A warm July rain suddenly washes down to the roots of the plants an overdose of manure, rich in ammoniacal salts, and the rank herbage so produced is unwholesome food. My first lesson, therefore, in manuring grass was that nitrogen, though most valuable in increasing the produce, and indispensable in restoring the condition, of exhausted land, cannot be used in large doses without materially diminishing the quality of the herbage. If called upon to explain this fact, I would suggest that plant-food to produce really healthy vegetation, should consist of a due admixture of several ingredients, of which ammonia, phosphoric acid, and potash, are most important. As the roots of plants cannot select the substances they require, but suck up all soluble matters with which they come in contact, if ammonia, which is extremely soluble, be presented to them in excess when compared with the other elements of their growth, the result is that sap is circulated through the plant of too stimulating character, and produces in the vegetable organisms results somewhat similar to those too often observed in the human subject who imbibes *too much soluble matter of a stimulating kind*: viz., high colour and vigorous vitality, but with a tendency to premature decay: in short, plants so treated are on the *high-road to gout*. If soils commonly contained a considerable amount of soluble phosphoric acid and potash, a reasonably large dressing of ammonia would probably produce unmixed benefit, such as we see to result from a liberal application of manure from the yard, which supplies all these substances to the growing plant in the exact proportions required; but, as the potash and phosphates contained in the soil itself are, for the most part, very slowly soluble, it is necessary to provide them in a more available form, in order to prevent ammonia from greatly predominating over the other ingredients, and thus injuring the quality of the produce.

Next to nitrogen, the most important manurial substance is phosphoric acid, and, after being disappointed with the result of ammoniacal dressings, I made various trials of the phosphates in different combinations. The great success which attended the use of bones on the dairy-lands in Cheshire, and the experience of all observant shepherds that turnips, manured with bones, bore more hard weather, and were better sheep-meat, than more showy crops grown with other tillage, led me to anticipate great advantage from a liberal use of bones or superphosphate on grass. In this, however, I was again disappointed. Bones improved the quality of the pasture, and somewhat increased the proportion of clovers and fine grasses to the coarser kinds, but I could not satisfy myself that the improvement was sufficient to pay the bill. Lesson the second therefore taught me that bones alone could not be depended upon for the renovation of grass land in general.



Having arrived at the point that neither nitrogen nor phosphoric acid alone was to be recommended, I tried them in combination with good results; but there was still something wanting to give the agriculturist complete command over the growth of herbage suited to his wants, and the next substance I thought likely to be of use was potash. It was suggested by the luxuriance of the vegetation produced wherever vegetable matters had been burnt, and the strength of the clover-plant where kelp, wood-ashes, or other manure containing potash had been applied. After several minor experiments with encouraging results, in 1867 I took in hand a field which was notoriously clover-sick, and where it was important to have a good plant of young seeds for sheep-feed, and the top-dressing specified above was specially compounded to meet the case. The result was a magnificent crop of clovers and trefoil, which carried ten head of ewes and lambs per acre through the very dry season 1868. This success encouraged me to try it largely the following year, and after five years' trial, on strong clay as well as on light land, on newly-laid grass and on old inferior pasture, I have had no instance of even partial failure. In the extraordinarily dry season of 1870, my seeds carried a full stock of sheep without the slightest appearance of giving way, and some old pastures so treated were full of clover and vetches, although previously conspicuous for the absence of the whole trifolium family. I will give one more instance, which was striking in its way. In the autumn of 1868 I applied the top-dressing to 40 acres of very bad old grass on strong clay. It had been mown frequently, but rarely manured, and the herbage was dry and coarse. The effect was remarkable. White clover, trefoil, and vetches, sprang up in abundance in the following spring, and both hay and aftermath were greedily eaten by all kinds of stock. In 1871 I gave this land a dressing of 40 bushels of soot per acre. Within three months the clover and trefoil had disappeared as if by magic. The crop of grass was a heavy one but coarse, and the hay, though well got, met with a very doubtful reception even from the milch cows, although, as is well known, milking cattle accept gratefully any amount of hay of any kind, unless mouldy or mow-burnt.

In 1858 I recommended that newly-laid grass should be mown the first season. I was well aware that, by so doing, not only was the condition of the land much reduced, but by allowing the stronger grasses to attain their full growth the first year, a tufty, irregular surface was given to the pasture, and the formation of the close even turf, which is so great a desideratum, was much retarded. Grazing with sheep was, however, so injurious to the clovers and finer grasses, that I considered mowing the lesser evil of the two. When, in 1858, I found that I had obtained the clue

to the growth of clover, I immediately adopted a *revised code* of laying down land to permanent pasture. In 1869 and 1870 I had 50 acres to lay down. Three fields, containing together 40 acres, were dressed twice with the mixture above recommended: 1st, when the barley and seeds were sown, and 2ndly, a few months after the barley-crop was harvested. Another field of ten acres, of better quality than the other three, I sowed down in good condition, but without the potash and superphosphate dressing. The whole four fields were grazed with sheep the first season. The three first-mentioned remained as full of clover and fine grasses at the end of the season as at the beginning, whereas the ten acres not so dressed, though carrying a good stock of sheep, gradually lost their plant of clover, and began the following spring to show indications of the dry, bent appearance, which I had previously found to supervene so generally in the second, and still more in the third, year after laying down. I mean for the future, therefore, to graze newly-laid grass for permanent pasture with sheep until firm enough to carry cattle, relying on the top-dressing to maintain the quality of the young grass against all comers.

The two men most competent to advise on scientific questions affecting British agriculture are undoubtedly Mr. Lawes and Professor Voelcker, and I am happy to be able to quote them both in support of the recommendations here given for the treatment of grass land. The experimental plots at Rothamsted (the produce of which is annually mown and removed) show conclusively that any application to grass land which does not contain potash, if repeated for several successive years, results in a decline, and eventually an extinction of the clovers, vetches, and finer grasses; and though Mr. Lawes is not yet satisfied that for general use potash can be recommended as a paying application, I am authorised to state that within the last few months his advice to a gentleman asking him to prescribe for some old pasture land which required renovation, was to apply  $1\frac{1}{4}$  cwt. of nitrate of soda,  $2\frac{1}{2}$  cwt. of superphosphate, and 3 cwt. of kainit per acre, which it will be observed differs very slightly from the mixture advocated above.

Professor Voelcker, in articles published in this Journal, has pointed out the excellent effect produced on clover by the use of superphosphate and potash salts on light land. He was, however, until very recently of opinion that no corresponding benefit was produced by this combination on clay; but I quote from a letter received from him within the last few weeks, which shows that he has somewhat modified that opinion: "More than twelve months ago you brought to my knowledge the fact that potash salts gave you a satisfactory result on your heavy land. From

all the experiments which I had tried with potash salts for a number of years upon heavy soils, no appreciable result was produced on the grass or root crops to which these salts were applied. Your experience, however, induced me last season to try a mixture of superphosphate with potash salts on some poor clay land in Kent, and the accounts which I received from several farmers who tried this mixture upon clover seeds on heavy land, and I may add also upon potatoes, are very satisfactory. I have myself seen the good effects which potash salts and superphosphate produced on clover and grass on moderately stiff land in the neighbourhood of Bromley, in Kent, and I believe this mixture will probably be found beneficial for grass land on the poor clays in Staffordshire, and, generally speaking, on the bad clays of the Coal Measures. A close examination of these clays, if I am not mistaken, will show that there are some clays which are greatly deficient in potash, and on such poor clay soils the application of potash salts no doubt will be attended with beneficial results. I am glad to have this opportunity of modifying to some extent the opinion which I expressed on the strength of a more limited experience than I now possess, namely, that salts of potash are likely to be useful only on light land, for the experience I had last year fully confirms your own that there are clay soils as well as light land which are benefited by the application of potash salts and superphosphate."

It will have been observed that throughout this article the means principally relied on for increasing our home production of meat are, *an extended use of artificial manures on pasture land and of feeding-stuffs for cattle at grass.* At the present prices of fat and lean stock, it will pay the farmer to adopt both systems simultaneously. The great difficulty is in making a beginning. The routine of years, possibly handed down for generations, cannot be broken through without a pang; but such pangs seldom outlive the first favourable balance-sheet, and it may be confidently stated that for some time past the farmers who have made most money are those who have paid as much attention to the improvement of their grass as to the growth of fine crops of corn or roots.

*Kirkby Hall, February, 1872.*

---

V.—*The Records of Contagious Cattle Diseases in Yorkshire during the years 1870-71.* By J. DENT DENT, M.P.

[A LETTER TO THE EDITOR.]

"MY DEAR SIR,—It has occurred to me that some readers of the Journal might be interested in the records of contagious

diseases amongst animals in Yorkshire, which, have been collected by the county constabulary since the carrying out of the provisions of the Contagious Diseases (Animals) Acts, 1869, was placed in their hands. Through the courtesy of Lieutenant-Colonel Granville Layard and Captains Hill and McNeill, the respective heads of the force in the East, North, and West Ridings, I am enabled to send you the Quarterly Returns of cases of Pleuro-Pneumonia, and Foot and Mouth Disease for the last two years. You will see that, as a whole, the East Riding, which is the most purely agricultural part of the county, has suffered the least, although the port of Hull, to which many German cattle are sent, is situated within it. This fact appears to negative the idea that the spread of these diseases, or their virulence, is proportionate to the introduction of foreign animals. The West Riding has suffered the most; this may be attributable partly to the fact that there was a great amount of Foot and Mouth Disease existing in this Riding when the Act was first put into operation, and still more that the West Riding Fairs are the great fairs for Irish cattle.

“Skipton, Knaresborough, Wetherby, and Wakefield, all have large fortnightly lean stock markets, which, especially during the autumn, are crowded with Irish beasts, many of most excellent quality, and invaluable for the use of our graziers; but others, much over-driven, over-crowded on shipboard and in railway trucks, and half starved in their progress from the Irish coast, are almost certain to be affected with disease either at the fair or on their arrival at the farms for which they are purchased. The North Riding, and the West, too, alike suffer from the great focus of disease in Yorkshire, the market at York. This fortnightly market is at certain seasons crowded with stock, principally imported from Ireland, and from this centre the Foot and Mouth Disease has at all times extended throughout the grazing districts of Yorkshire, as also did the cattle plague some years ago. There is need of a far more effective supervision of fairs, and a more general sense of the inconvenience caused by Foot and Mouth Disease to farmers themselves, before any real progress will be made in checking it. At present, many farmers who purchase Irish grazing cattle each autumn, intending to winter them on straw and turnips, and sell them out fat from grass in the ensuing year, consider it almost a matter of course that their cattle will have this epidemic; and they desire to get it over as early as possible, before the beasts gain flesh. If the epidemic does not attack them until they are nearly fat, there is a loss of a month or six weeks grazing; but if they are affected soon after their arrival the loss appears trivial, the attacks seldom lasting more than ten days. The Returns, I think, will show that the disease

seldom terminates fatally, the loss from death amongst cattle being trifling, and amongst sheep almost infinitesimal.

“On the other hand, Pleuro-Pneumonia is as fatal as ever; and from the Returns we may conclude that 50 per cent. of the animals attacked by this disease fall victims to it. I feel satisfied that immediate slaughter will always be found the best resource for the farmer whose stock is affected, even if there be no compensation awarded, as the flesh of the animal when first attacked is not generally considered to be unfit for food,\* and the chance of recovery is most uncertain. I am, however, very much inclined to believe that if all animals suffering from Pleuro-Pneumonia were slaughtered as soon as they were attacked, and if a reasonable compensation were made to the owner, this disease might soon be eradicated, supposing the system to be universally and compulsorily carried out. At present different local authorities take different views of the best course to pursue, and there is not sufficient uniformity in their proceeding.

“We find that in 1870, in the East Riding of York, out of 73,575 cattle, only 6 died from Foot and Mouth Disease, and none from Pleuro-Pneumonia. In the North, out of 143,730, 100 died or were killed in consequence of Foot and Mouth Disease, and 30 in consequence of Pleuro-Pneumonia. In the West, out of 220,986, 117 died or were killed on account of Foot and Mouth Disease, and 148 on account of Pleuro-Pneumonia, so that out of 438,291 cattle, 401 died from these diseases, being about one in 1000. In 1871, in the East Riding, the losses from Foot and Mouth Disease were, 18 from Pleuro-Pneumonia, and 20 from Foot and Mouth Disease, out of 72,406; in the North 57 from Pleuro-Pneumonia, and 61 from Foot and Mouth Disease, out of 140,220; in the West, 81 from Pleuro-Pneumonia, and 113 from Foot and Mouth Disease, out of 217,088; making a total loss from both diseases of 340 out of 429,714, being a rather more favourable return than for 1870, in spite of the widespread outbreak of Foot and Mouth Disease in the autumn of that year. On the whole, therefore, I cannot but hope that the Acts are working satisfactorily, when I compare this loss with the losses which occurred under my own personal observation before the days of the Cattle

---

\* Since writing the above, I find that the Local Government Board have introduced the “Public Health Bill,” which proposes to enact, in clauses 44 and 45, that “all milk of any animal suffering from any contagious or infectious disease; as defined by the Contagious Diseases (Animals) Act, 1869, or from any tubercular disease, shall be deemed unwholesome and to be unfit for the food of man, and that any person selling for human food any animal, carcase or meat, so diseased shall on conviction, pay a penalty not exceeding 20l.”

Plague, when the restrictions at that time in force very nearly freed us from all other cattle diseases.

“ I am truly yours,

“ JOHN DENT DENT.

“ Ribston Hall, 21st January, 1872.”

RETURNS, showing the Progress of PLEURO-PNEUMONIA Quarterly in the North, East, and West Ridings of Yorkshire under the Constabulary, between January 1, 1870, and December 30, 1871.

DATE.				EAST RIDING.			
				Attacked.	Killed.	Died.	Recovered.
Quarter ending	March, 1870	..	..	..	Nil.	..	..
„	June, „	..	..	..	Nil.	..	..
„	Sept., „	..	..	..	Nil.	..	..
„	Dec., „	..	..	..	Nil.	..	..
„	March, 1871	..	..	..	Nil.	..	..
„	June, „	..	..	..	Nil.	..	..
„	Sept., „	..	..	..	22	12	10
„	Dec., „	..	..	..	8	6	2
Totals				..	..	..	12
				30	18	..	12

DATE.				NORTH RIDING.			
				Attacked.	Killed.	Died.	Recovered.
Quarter ending	March, 1870	..	..	..	..	..	..
„	June, „	..	..	..	24	3	11
„	Sept., „	..	..	..	31	2	20
„	Dec., „	..	..	..	13	..	7
„	March, 1871	..	..	..	23	4	10
„	June, „	..	..	..	38	2	13
„	Sept., „	..	..	..	27	1	10
„	Dec., „	..	..	..	12	2	7
Totals				..	..	..	78
				168	14	73	78

DATE.				WEST RIDING.			
				Attacked.	Killed.	Died.	Recovered.
Quarter ending	March, 1870	..	..	..	65	28	15
„	June, „	..	..	..	88	19	32
„	Sept., „	..	..	..	46	18	20
„	Dec., „	..	..	..	35	11	18
„	March, 1871	..	..	..	29	11	4
„	June, „	..	..	..	39	17	23
„	Sept., „	..	..	..	29	8	8
„	Dec., „	..	..	..	28	16	9
Totals				..	..	..	129
				359	128	101	129

RETURNS, showing the Progress of FOOT AND MOUTH DISEASE Quarterly in the North, East, and West Ridings of Yorkshire under the Constabulary, between January 1, 1870, and December 30, 1871.

DATE.				EAST RIDING.			
				Attack d.	Killed.	Died.	Recovered.
<b>CATTLE.</b>							
Quarter ending	March, 1870	..	..	973	..	3	970
„	June, „	..	..	238	..	..	238
„	Sept., „	..	..	1,386	..	3	1,383
„	Dec., „	..	..	988	..	..	988
„	March, 1871	..	..	265	..	..	265
„	June, „	..	..	73	..	..	73
„	Sept., „	..	..	1,279	..	3	1,276
„	Dec., „	..	..	3,640	..	7	3,633
	Totals	..	..	8,842	..	16	8,826
<b>PIGS.</b>							
Quarter ending	March, 1870	..	..	105	..	9	96
„	June, „	..	..	16	..	..	16
„	Sept., „	..	..	124	..	2	122
„	Dec., „	..	..	119	..	11	108
„	March, 1871	..	..	35	..	2	33
„	June, „	..	..	9	..	6	3
„	Sept., „	..	..	184	..	21	163
„	Dec., „	..	..	637	..	4	633
	Totals	..	..	1,229	..	55	1,174
<b>SHEEP.</b>							
Quarter ending	March, 1870	..	..	1,321	..	2	1,319
„	June, „	..	..	20	..	..	20
„	Sept., „	..	..	51	..	..	51
„	Dec., „	..	..	1,003	..	..	1,003
„	March, 1871	..	..	353	..	..	353
„	June, „	..	..	..	..	..	..
„	Sept., „	..	..	46	..	..	46
„	Dec., „	..	..	9,538	..	1	9,537
	Totals	..	..	12,332	..	3	12,329

## RETURNS, &amp;c.—continued.

				NORTH RIDING.				
DATE.				Attacked.	Killed by Owner.	Died.	Recovered.	Under Treatment.
CATTLE.								
Quarter ending	June,	1870	.. ..	1,104	..	7	1,097	..
..	Sept.,	..	.. ..	7,489	4	79	7,406	..
..	Dec.,	..	.. ..	1,538	..	10	1,528	..
..	March,	1871	.. ..	1,309	..	7	1,302	..
..	June,	..	.. ..	480	..	5	475	..
..	Sept.,	..	.. ..	7,080	2	32	74,06	..
..	Dec.,	..	.. ..	6,441	..	15	5,389	1,037
Totals .. ..				25,441	6	155	24,243	1,037
PIGS.								
Quarter ending	Sept.,	1870	.. ..	396	..	11	385.	..
..	Dec.,	..	.. ..	..	Nil.	..	..	..
..	March,	1871	.. ..	224	..	9	215	..
..	June,	..	.. ..	228	..	..	228	..
..	Sept.,	..	.. ..	245	..	35	210	..
..	Dec.,	..	.. ..	531	..	5	431	95
Totals .. ..				1,624	..	60	1,469	95
SHEEP.								
Quarter ending	Sept.,	1870	.. ..	118	..	..	118	..
..	..	..	.. ..	..	..	..	..	..
..	Sept.,	1871	.. ..	1,460	..	..	1,460	..
..	Dec.,	..	.. ..	2,274	..	..	1,497	777
Totals .. ..				3,852	..	..	3,075	777

## WEST RIDING.

DATE.				Attacked.	Killed.	Died.	Recovered.
CATTLE.							
Quarter ending	March,	1870	.. ..	7,053	21	37	6,458
..	June,	..	.. ..	4,459	5	33	4,776
..	Sept.,	..	.. ..	4,402	2	15	3,888
..	Dec.,	..	.. ..	2,424	..	4	2,808
..	March,	1871	.. ..	1,475	..	3	1,683
..	June,	..	.. ..	691	1	3	737
..	Sept.,	..	.. ..	8,540	2	41	6,642
..	Dec.,	..	.. ..	9,951	6	57	11,030
Totals .. ..				38,995	37	193	38,022



## RETURNS, &amp;c.—continued.

DATE.	WEST RIDING.			
	Attacked.	Killed.	Died.	Recovered.
PIGS.				
Quarter ending March, 1870 .. .. .	555	7	33	509
"   June,   "   "   "   "   "   "	106	..	2	114
"   Sept.,   "   "   "   "   "   "	154	..	4	135
"   Dec.,   "   "   "   "   "   "	237	..	18	231
"   March, 1871 .. .. .	87	..	..	90
"   June,   "   "   "   "   "   "	51	1	..	49
"   Sept.,   "   "   "   "   "   "	706	..	18	579
"   Dec.,   "   "   "   "   "   "	986	..	28	1,030
Totals .. .. .	2,882	8	103	2,737
SHEEP.				
Quarter ending March, 1870 .. .. .	708	..	8	689
"   June,   "   "   "   "   "   "	23	..	..	34
"   Sept.,   "   "   "   "   "   "	114	..	..	85
"   Dec.,   "   "   "   "   "   "	105	..	..	100
"   March, 1871 .. .. .	125	..	..	159
"   June,   "   "   "   "   "   "	..	..	..	..
"   Sept.,   "   "   "   "   "   "	276	..	..	122
"   Dec.,   "   "   "   "   "   "	3,194	1	..	2,510
Totals .. .. .	4,545	1	8	3,699

VI.—On the Composition and Agricultural Value of Earth-Closet Manure. By Dr. AUGUSTUS VOELCKER, F.R.S.

THE agricultural utilization of the sewage of towns is a problem which cannot yet be said to have been solved in an entirely satisfactory manner.

All persons who have seriously considered the subject have come to the conclusion that the removal of human excrements of large populations from the urban districts to the country, where they are wanted, without creating a nuisance or injuring the health of the inhabitants—and the economical utilization of these matters for the production of food—are questions surrounded by numerous practical difficulties of no ordinary kind.

In the country—in small country towns, and in isolated establishments such as county prisons, workhouses, and asylums—the disposal of human excretal matters presents no great difficulty; but their removal from towns is generally attended with considerable expense, no matter what particular system the authorities may adopt.

By degrees the town authorities are learning the disagreeable lesson that materials which are excellent fertilizers when safely incorporated with the soil are a nuisance in a town, and cause expenses that are all the greater the more completely the plan of removal accords with the requirements of modern civilization.

There is no doubt that excretal matters and all kinds of house-refuse are removed from towns more rapidly, with less nuisance to the inhabitants, and with less injury to their health, by means of water, than in any other way that can be adopted on a large scale. There can be, further, no doubt that the land is the proper medium for the reception of all excrementitious matters, and that nothing effects so complete and rapid a deodorization and disinfection of putrid animal matter of every kind as a well-aërated soil.

Boussingault has shown that there is a larger proportion of oxygen in the air condensed between the particles of a porous soil than in the atmosphere above the land. In the condensed condition in which oxygen exists in a porous soil, it no doubt acts much more powerfully in oxidizing organic matters than the free oxygen of the air. Its effects in that respect may indeed be compared with the effects of oxygen condensed in spongy platinum, which effects manifest themselves, as is well known, by the instantaneous production of light or heat—the visible effect of the chemical combination of hydrogen and oxygen, when a current of hydrogen is directed upon a pellet of spongy platinum.

There is no oxidizing agent equal to a porous soil, which is always at hand in almost unlimited quantities, and equally effective in destroying animal effluvia and the permanently prejudicial properties of excrementitious matters of every description. Few axioms are so true as that which enforces the propriety of returning to the land the fertilizing materials which are removed from it in the produce. In other words, the nuisance of a town population ought to be utilized on the land for the production of food. The wonderful disinfecting and absorbing properties of porous soils long ago attracted the attention of practical men and scientific observers; but greater precision to chemical inquiries into these valuable properties has been given only of late years by scientific chemists, after Mr. H. S. Thompson had made the discovery that soils not only possessed the power of absorbing certain volatile and fœtid matters, but also of decomposing salts of ammonia, retaining the fertilizing base ammonia, and permitting the less important acid constituents of ammoniacal salts to percolate through the soil in combination with lime, magnesia, or other abundant soil constituents. In a series of classical

experiments on the powers of cultivated soils to retain the fertilizing elements of manure, Professor Way showed that all soils possess, in a greater or less degree, the power not only to absorb ammonia, potash, phosphoric acid, and other manuring constituents, but likewise to decompose solutions of their compounds, and to retain all their more important fertilizing constituents.

A practical application of the power of dry and sifted earth, especially if it partakes of the nature of clay, to absorb and retain ammonia and other fertilizing matters, has been made by the Rev. Henry Moule, Vicar of Fardington, Dorset, who has constructed, under the protection of a patent, several forms of earth-closets, by which the supply, admixture, removal, and drying of the earth can be satisfactorily and economically performed.

Mr. Moule has the merit of having given to the public a simple and ingeniously-contrived apparatus, which is capable of doing good service in many places; more especially in sick rooms, public establishments, such as county prisons and unions, and country-houses where a good supply of water cannot be commanded; and credit is due to him for having pointed out the *repeated* action, and consequently the fitness for repeated use of the same earth.

He showed that a comparatively small portion of dry and sifted earth ( $1\frac{1}{2}$  pint) is sufficient, by covering the deposit, to arrest effluvium, and to prevent fermentation and the consequent generation of noxious gases; and further, that if within a few days the mass which would be formed by the repeated layers of deposit be intimately mixed by a spade, or by a mixer made for the purpose, in a few minutes neither to the eye nor sense of smell is anything perceptible but so much earth.

Ordinary garden surface-soil may be used in Moule's earth-closet, especially if it contains a good proportion of clay; but if clay soil be scarce, an admixture of coal-ashes or street sweepings is not objectionable. There is thus no difficulty in procuring a supply of earthy matter.

Many persons who have used earth-closets have publicly expressed great satisfaction as regards the efficiency of this system; and it must be admitted that it is of great advantage, in a sanitary point of view, in the cases of sick rooms, detached houses, or villages, or even small country towns.

Where the earth required for absorption can be readily procured in a dried and sifted state, and the land for the utilization of the compost is in close proximity, the earth-closet system recommends itself as a thoroughly efficient plan of disposing of human excreta and the utilization of their fertilizing constituents at the smallest expense, and in some cases even with economy.

Although I have consistently advocated the wet system, or water-closet plan, for large towns, I am convinced that the dry or earth-closet plan is preferable to the adoption of sewage arrangements in villages or suburban districts, inhabited by people in a humble position of life; and I would impress strongly upon Local Boards of Health the propriety of well considering whether in such localities the earth-closet system does not meet the sanitary requirements of the case, before they have recourse to expensive sewage operations entailing, as they do everywhere, a more or less considerable tax upon the people, whose earnings are such as require to be expended according to the strictest rules of economy. It is obvious that if a plan could be devised by which human excretal matters could be collected and removed from dwellings, without either nuisance or injury to health, and obtained economically in a concentrated, dry, and portable condition, their utilization would be much more perfectly attained by such means than by the water-system. The questions naturally present themselves, does the earth-closet plan meet these demands, and is it applicable for towns as well as for the country?

The objections which are made to the dry or earth-closet system are:—

1. The difficulties and expense of the supply and preparation of the soil in the case of towns.
2. The cost of carriage of a bulky earth compound to the country.
3. The fact that but little of the urine, containing in round numbers  $\frac{3}{8}$ ths of the manuring constituents of mixed solid and liquid human excreta, would reach the earth compost; and
4. That in the manure produced, the more valuable fertilizing matters are so largely diluted with comparatively useless common earth, that beyond a very short distance from the locality where the earth compost is produced the cost of carriage would be greater than the manure is worth.

These objections, it must be confessed, are not readily met in the case of towns, for the difficulties and the expense of procuring a supply of suitable earth, of storing it, preparing it for repeated use, and the cost of removal of the compost to the country are no doubt so great that, even admitting that by the dry plan human excreta could be removed from towns as rapidly and with as much salubrity as by the wet or water system, the latter would be preferable in an economical point of view, unless it could be shown that the earth or dry system really produces a concentrated manure of intrinsic value. We are thus led to inquire into the composition and money value of the manure which can be produced by the repeated use of prepared soil, as recommended by Mr. Moule.

A favourable opportunity of ascertaining the composition of the earth used repeatedly in one of Moule's earth-closets presented itself when I received a sample for analysis which had been used four times in succession, and been dried each time after removal from the earth-closet.

This sample furnished the following results on analysis:—

*Composition of a sample of Earth-Closet Manure used four times in succession, and dried.*

Moisture (loss on drying at 212° Fahr.) .. .. .	1.49
*Organic matter and water of combination .. .. .	6.56
Oxide of iron and alumina .. .. .	14.57
Tribasic phosphate of lime (bone-phosphate) .. .. .	1.46
Carbonate of lime .. .. .	9.47
Magnesia .. .. .	2.20
Potash .. .. .	1.31
Chloride of sodium .. .. .	.82
Insoluble siliceous matter (clay) .. .. .	62.12
	100.00
* Containing nitrogen .. .. .	.39
Equal to ammonia .. .. .	.47

The manure was perfectly inodorous and inoffensive in appearance. It contained about 1½ per cent. of bone-phosphate, but only .39 per cent. of nitrogen, equal to not quite ½ per cent. of ammonia, and consequently was not of great fertilizing value.

The earth having been dried after each use by fire-heat, it occurred to me that probably some of the ammonia might have been driven off by too great a degree of heat in the drying operation; and I, therefore, was glad to receive for examination another sample which had been used five times in the earth-closet, and not been dried by fire-heat after the fifth removal from the closet, but been allowed to become air-dry. In this condition I found it to contain in 100 parts:—

Moisture (loss at 212° Fahr.) .. .. .	12.97
*Organic matter and water of combination .. .. .	7.78
Oxide of iron and alumina .. .. .	9.24
Tribasic phosphate of lime (bone-phosphate) .. .. .	1.05
Carbonate of lime .. .. .	9.19
Magnesia .. .. .	2.57
Potash .. .. .	.66
Chloride of sodium .. .. .	.64
Insoluble siliceous matter (clay) .. .. .	55.90
	100.00
* Containing nitrogen .. .. .	.41
Equal to ammonia .. .. .	.49

Like the preceding sample, it was quite inoffensive to the senses. Although it had been used five times, and had not been dried the

last time by fire-heat, it scarcely contained more nitrogen than the preceding sample, and somewhat less phosphate of lime and potash. In the former sample it will be seen I found 14·57 per cent. of oxide of iron and alumina, and 62·12 per cent. of insoluble siliceous matter (clay), whilst the analysis of the second sample shows only 9·24 per cent. of oxide of iron and alumina, and 55·90 per cent. of mixed siliceous matter. It appears, therefore, that the earth of the two samples was not precisely the same, and hence the analyses of the two samples do not admit of strict comparison. Nevertheless, they afford plain evidence of the fact, that the proportion of nitrogen in the earth-closet manure is but inconsiderable, even when the earth has been used repeatedly in the closet.

Both samples, I may observe, were free from nitrates; and the nitrogen which is stated in the analysis includes both the nitrogen present in the nitrogenous organic matters and in the ammonia-salts of the earth-closet manure. I had no opportunity of ascertaining what was the composition of the dried and sifted earth before its employment in the closet, and cannot, therefore, say definitely how much nitrogen or phosphoric acid and potash it originally contained, and to what extent its original fertilizing matters were increased by repeated use.

The results of the preceding analyses, it must be confessed, are disappointing in an agricultural point of view; and although not quite conclusive, they hold out but little prospect for the production of a fairly concentrated manure by means of the repeated use of earth in the dry closet. As a disinfecting agent, earth answers so admirably that I was loth to arrive at too unfavourable an opinion as regards the agricultural value of the earth-closet manure; and I therefore thought it well to institute further inquiries before expressing a definite opinion of the probable value of this kind of manure.

Some of the readers of the *Journal* are perhaps aware that the dry-earth system has been in operation for some years past in the West Riding prison, Wakefield, with marked success. Capt. Armytage, the governor of the prison, who has paid much attention to practically carrying out this system, has kindly furnished me with information on some points of interest bearing upon the subject. The prison, he informs me, contained in 1870, on an average 1451 cells. As many as 776 dry-earth closets are in use in the cells and workrooms, and are highly approved. Besides the earth-closets there are 675 water-closets. Moule's system was introduced in Midsummer, 1866, and has been continued in use without interruption.

Capt. Armytage writes to me: "We use the ordinary Moule's closet, or a still simpler box, where the earth is applied out

of a small scoop by hand, instead of the self-acting machinery of Moule's closets, which, with ordinary care, acts very well. You must be aware what class of men and women we have to deal with in working out experiments; and I can only say that, after more than three years, I am satisfied that the dry-earth plan is the only sound system that can be worked out, especially among the lower classes and in towns, my principle being to keep all sediments out of the drains. The urine now is collected into tanks, and is sold, or used for manuring the ground, or is thrown upon the earth compost. We find an absence of all smells, that formerly were quite overpowering; and even in the manipulating shed no smell can be discerned, except at the time of turning the compost, and then the smell perceptible in the shed is more that of a Peruvian guano shed than anything else."

The earth used in the closet is common soil, containing a good proportion of clay. It is dried and passed through a half-inch riddle, and the work is done by the prisoners. Hitherto it has been obtained in the prison grounds, or has been bought from builders at 6*d.* a load. 5 cwt. of earth per annum is used per head, about 1½ lb. being allowed for each time the closet is used. The whole of it is used twice or three times, and it might no doubt be used more frequently if required. Large bins containing 2 tons each are set apart for storing the earth after use. The bins are under cover; and in summer no artificial heat is required to dry the earth compost sufficiently for re-use. After remaining about 5 weeks in the bins, the earth is passed through a riddle and used again. Neither ashes nor other dry materials are used with the earth, and nothing except *feces*, with more or less urine, is allowed access to the closets. In winter a slow fire of cinders under a hollow brick floor soon dries the wet earth sufficiently to be passed through a half-inch sieve, and to be fit for repeated use in the closets, which are emptied weekly.

The following are the printed instructions which Captain Armytage has given to warders as to the mode of using the earth-closets:—

“INSTRUCTIONS TO WARDERS AS TO MODE OF USING THE  
EARTH-CLOSETS.

“Not more than one pan of earth must be placed in the hopper-box at one time, so that when the pan below is filled, the hopper-box above will be empty.

“In making the daily inspection, the Warder will take care that if the hopper be empty (or nearly so), the plan below, with

its cover, is taken out and replaced with another from the reserve pans.

“There must be ten pans in reserve in each division. Pans will be kept ready at the earth shed, so that the Warder will only have to exchange used pans for fresh ones that will form the reserve on the division. By this arrangement each division of the prison using earth-closets can empty and replenish, if necessary, ten closets daily. The time for attending to this duty should be before breakfast.

“The Warder of each division may take five prisoners, when necessary, to the earth-shed to make the exchange of pans. These men will be selected for the purpose by the Governor or Deputy, and will wear a white star to denote that they may be so employed.

“The principal Warders are held responsible that these instructions are carried out.

“Closets out of repair must be immediately replaced. One closet will be kept in reserve in each division.

“Prisoners using anything besides paper, after being warned not to do so, must be reported for disobeying orders.

“Each urine pot must have a properly fitting tin lid kept on it with a little water in the rim.

“G. ARMYTAGE, Governor.

“*West Riding Prison, 28th August, 1868.*”

In the course of the year from 55 to 60 tons of earth-manure are obtained, which is chiefly used on the prison grounds. In 1870 about 12 tons were sold at 1*l.* per ton when the earth was once used, 2*l.* when twice used, and 3*l.* thrice used. It has had remarkable success in growing onions, and has been used with advantage for potatoes, vegetables, and garden produce in general. Half a ton per acre of the earth used once in the closets has also been successfully applied to grass land, and 1 ton per acre produced 2 tons 3 cwt. of hay.

In a second experiment 1 ton of the earth-manure (once used) produced 2 tons 2 cwt. of hay.

In conclusion, Captain Armytage informs me that, in consequence of the introduction of the dry-earth-closet system into the prison, the atmosphere of the cells has been much improved, and, no doubt, been rendered more healthy. The earth-closets are in use in the prison hospitals and workrooms, containing from 20 to 50 men. In the public closets in the workroom the earth is thrown upon the faces three times a day, and the contents are removed as required.

Captain Armytage also sent me samples of the dry and sifted earth, both before its use in the closets and after it had



passed once, twice, and three times through the closets. The earth appeared to be ordinary garden soil, containing a considerable proportion of clay. An analysis of it in its natural state yielded the following results:—

*Composition of air-dry sifted Earth for use in the Earth-Closet.*

Moisture .. .. .	9·94
*Organic matter and water of combination .. .. .	8·86
Oxide of iron and alumina .. .. .	11·67
Phosphoric acid .. .. .	·17
Carbonate of lime .. .. .	2·01
Magnesia .. .. .	1·30
Alkalies and loss in analysis .. .. .	1·22
Insoluble siliceous matter (sand and clay) .. .. .	64·83
	100·00
* Containing nitrogen .. .. .	·28
Equal to ammonia .. .. .	·34

The preceding analysis gives a good representation of the composition of rich garden mould.

The samples of the earth, after having been used once, twice, and three times, were not equally dry, as will be seen by the subjoined tabulated results, which represent the composition of the three samples of earth-manure in the condition in which they reached me.

COMPOSITION of Three Samples of EARTH-CLOSET MANURE from WEST RIDING PRISON, WAKEFIELD.

	No. 1. Earth once used.	No. 2. Twice used.	No. 3. Three times used.
Moisture .. .. .	21·69	11·81	13·81
*Organic matter and water of combination .. .. .	7·67	10·17	10·53
Oxide of iron and alumina .. .. .	12·65	12·43	10·76
Phosphoric acid .. .. .	·19	·39	·44
Carbonate of lime .. .. .	1·76	1·88	1·84
Magnesia .. .. .	2·06	·68	·78
Alkalies and loss in analysis .. .. .		·64	·64
Insoluble siliceous matter (clay and sand) .. .. .	53·98	62·00	61·20
	100·00	100·00	100·00
* Containing nitrogen .. .. .	·29	·37	·44
Equal to ammonia .. .. .	·35	·45	·53

All the samples were inoffensive in appearance, and free from disagreeable smell.

As the percentage of moisture in the original earth and in

the three samples of earth-closet manures varied a good deal, the preceding analytical data do not admit of being readily compared with each other. I have, therefore, calculated what the composition of the four samples would be when dried at the uniform temperature of 212° Fahrenheit.

The following Table expresses their composition in a perfectly dry state :—

COMPOSITION of EARTH and Three Samples of EARTH-CLOSET MANURE produced at WEST RIDING PRISON, WAKEFIELD, in dry state (dried at 212° Fabr.).

	No. 1.	No. 2.	No. 3.	No. 4.
	Earth for use in Closets.	Earth once used in Closets.	Earth twice used in Closets.	Earth thrice used in Closets.
*Organic matter and water of combination .. .. . }	9·88	9·79	11·53	12·22
Oxide of iron and alumina ..	12·95	16·15	14·11	12·48
Phosphoric acid .. .. . }	·18	·25	·44	·51
Carbonate of lime .. .. . }	2·21	2·25	2·13	2·14
Magnesia .. .. . }	1·44	2·63	·77	·90
Alkalies and loss in analysis ..	1·35		·72	·74
Insoluble siliceous matter (clay and sand) .. .. . }	71·99	68·93	70·30	71·01
	100·00	100·00	100·00	100·00
* Containing nitrogen .. .. . }	·31	·37	·42	·51
Equal to ammonia .. .. . }	·37	·45	·51	·62

A glance at the preceding analyses shows that the proportion of nitrogen in the soil increases but very little each time it is removed from the closet.

Used once the soil gained only ·06 per cent. of nitrogen, used twice it gained ·11 per cent., and three times ·20 per cent. If we divide by 3 the increase of nitrogen in the earth-manure passed three times through the closet, supposing the manure to be perfectly dry, we obtain ·066 as the average increase of nitrogen each time it is passed through the closet. It will further be seen that after the soil had been used three times over, the total increase of nitrogen amounted to only two-third of the small quantity originally present in the soil.

The proportionate increase of phosphoric acid in the three samples of earth-manure, as might have been expected, is rather larger than that of nitrogen, but, after all, the soil in a perfectly dry state, after having been used three times, contained only  $\frac{1}{2}$  per cent. of phosphoric acid; or a ton of such soil contained only 11 lbs. of phosphoric acid in round numbers, which is equal to 25 lbs. of bone phosphate of lime. Half a cwt.

bone-dust would supply all the phosphoric acid which was contained in 1 ton of dry soil after it had been passed three times through the closet.

The increase of nitrogen in earth-manure I need hardly say is likely to be greater in the houses of the wealthy or well-to-do people than in prisons or unions, where a less generous diet prevails; and where, consequently, the food is worked out, so to speak, more perfectly and the excreta are poorer in nitrogen than in the houses of the wealthier and better fed classes. Still, even under the most favourable circumstances, the accumulation of nitrogen in earth-manure, for reasons which I shall mention presently, cannot but be very inconsiderable.

In proof of this assertion I may quote some trials which Dr. Gilbert has lately made with the earth-closet plan.

Fourteen cwt. of air-dried and sifted clayey soil were set aside by Dr. Gilbert for experiment. From one-third to one-half of the whole was used before it was necessary to empty the pit. When removed the mass appeared uniformly moist throughout, and neither fæcal matter nor paper was observable in it; nor was the process of emptying accompanied by any offensive smell. After exposure, and occasional turning over on the floor of a shed, the once used soil was resifted, and again passed through the closet.

The percentage of moisture and of nitrogen in the natural soil, and after passing once or twice through the closet, were found by Dr. Gilbert as follows:—

	Before use.	After using once.	After using twice.
Percentage of moisture in air-dried; and sifted soil (loss at 212° Fahr.) }	8·440	9·970	7·710
Percentage of nitrogen in air-dried } and sifted soil .. .. . }	·067	·216	·353
Percentage of nitrogen in soil dried } at 212° Fahr. .. .. . }	·073	·240	·383

Calculated upon the air-dried condition, the increase in the percentage of nitrogen was only about ·15 each time the soil was used; and even after using twice, Dr. Gilbert observes, the soil was not richer than good garden-mould, and he adds, "It is obvious, therefore, that such a manure, even if disposed of free of charge, would bear carriage to a very short distance only." I fully concur in this view of the matter, for my own analyses have given me even less favourable results than those on which Dr. Gilbert's opinion is founded.

In estimating the money value of the earth-closet manure it is but fair to deduct from the value of the compost that of the earth used in its production. Taking for a basis of calculation the composition of the perfectly dry earth, and the three samples of closet-manures produced in the West Riding Prison, we have more specially to consider the relative proportions of phosphoric acid and of nitrogen in the four samples.

In the dry earth before use I found  $\cdot 18$  per cent. of phosphoric acid, and  $\cdot 31$  per cent. of nitrogen. Once used in the closet the earth compost was found to contain only  $\cdot 07$  per cent. more phosphoric acid, and  $\cdot 06$  per cent. more nitrogen than it did before. These differences are quite trifling, and it may be said with perfect justice, that the earth, after having been used once, is not more valuable for manuring purposes than in its original dry and sifted condition.

On comparing the amount of phosphoric acid and nitrogen in the earth passed twice through the closet, we find an increase of only  $\cdot 26$  per cent. of phosphoric acid, and  $\cdot 11$  per cent. of nitrogen; or, in other words, a ton of the compost twice used contained only  $5\cdot 824$  lbs., or, in round numbers, 6 lbs. more phosphoric acid, and  $2\frac{1}{2}$  lbs. more nitrogen than the original earth.

Allowing  $4d.$  for the value of a pound of phosphoric acid, and  $10d.$  for the value of a pound of nitrogen, it will be found that the earth twice passed through the closet was worth  $10d.$  more per ton for the phosphoric acid, and  $2s. 1d.$  for the nitrogen which it contained more than the soil before use; or, that the total value of the earth twice used was  $2s. 11d.$ , or say  $3s.$ , more per ton than a ton of dry earth before use.

On making a similar comparison with the earth thrice used, we find in the latter an increase of only  $\cdot 33$  per cent. of phosphoric acid, and  $\cdot 20$  per cent. of nitrogen; or, a ton of earth thrice used contained  $7\cdot 39$  lbs. more phosphoric acid, and only  $4\cdot 48$  lbs., or in round numbers,  $4\frac{1}{2}$  lbs. more nitrogen than the soil before use. These figures show an increased money value of  $2s. 5\frac{1}{2}d.$  in phosphoric acid and  $3s. 9d.$  in nitrogen. In other words the earth, passed three times through the closet, in a perfectly dry state was worth only  $6s. 2\frac{1}{2}d.$  more per ton than dry garden mould of the composition of the soil employed in the experiments.

If the agricultural value of earth-closet manure is really so low as stated by me, how does it happen, it may be asked naturally, that market-gardeners and others who have made trials with this description of manure, put a value upon it varying from 1 to  $3l.$  a ton? In reply to this very pertinent question, I would say that the high estimate of the value of

earth-closet manure does not rest on any solid foundation, but upon the exaggerated view which many people entertain with respect to the money value of human excreta. Numerous examples might be quoted in proof of the fact that night-soil manures, prepared animal refuse matters of various kinds, sewage manures, and similar fertilizers are constantly offered for sale at prices which do not at all correspond with their intrinsic value, and, for a time, find purchasers if the price does not exceed 3*l.* a ton. Everybody who is acquainted with the nature of farming operations and with the difficulty of estimating and tracing to their true source the effects of manure, must have noticed that, for a time, manures like that produced by the A B C sewage process, find a sale at a price which is many times greater than the intrinsic value of their fertilizing constituents, and that even the poorest manures may find a temporary sale, particularly if the price is temptingly low.

There can be no doubt that the solid and especially the liquid excreta of man are richer in fertilizing matters than the excrements of the horse, cow, pig, or sheep. The food of man, being a mixed vegetable and animal diet, is richer both in phosphates and in nitrogen than the more bulky food upon which those animals are fed; and as the greater portion of the phosphates and nitrogen, upon which the value of manure chiefly depends, passes through the body into the excrements, the fertilizing value of human excreta unquestionably is greater than the excrements of horses, cows, pigs, or sheep. Hence human excreta are highly esteemed as manuring agents in China, Japan, and Flanders, and all countries where the primitive mode of collection and transportation of these matters is considered no obstacle to their utilization. The manner of collecting and removing human excretal matters in these countries is, however, such as to be quite inadmissible with our modern notions of cleanliness, decency, comfort, and health.

In considering the economic value of human excreta, we have to take into account not merely their intrinsic fertilizing properties in an unmixed state, but also the condition in which they reach the farmer in a civilized country like England. Mixed with a large bulk of ashes or earth or diffused in a large body of water the same fertilizing matters, it is plain, cannot have so great a value as in an undiluted state. It has been stated that the excretal matters, as they leave the body, sell in Belgium for about 1*l.* per person per annum; but this is not the case. Some years ago, in travelling through Belgium and Germany, I made special inquiries into the manner of collecting and utilizing human excreta in various Continental towns, and I took particular

pains to ascertain what profit was realized by the disposal of these matters in different towns on the Continent.

As the result of personal observations and inquiries on the spot, I may state that in Belgium the town population seldom realizes by the disposal of their excretal matters as much as one franc ( $9\frac{1}{2}d.$ ) per head per annum. In many cases I found nothing whatever is realized by the town populations when their excretal matters are collected in tanks or cesspools as free as possible from all extraneous matters; and in not a few cases their removal entails some cost to the inhabitants.

In 1864, the Prussian Government commissioned Messrs. C. v. Salviati, O. Röder, and Dr. Eichhorn to investigate the modes of collection, removal, and utilization, in various Continental towns; and, in their report, the Prussian Commissioners, who visited various towns in Belgium, France, and Germany, showed not only that the householders seldom realized anything like a franc per head per annum for their excretal matters, but that, in the majority of towns, they had to pay something for the removal. It is surprising that, in the face of the reports of individuals who have investigated the subject on the spot, and in spite of reliable official reports, embodying the results of personal observations and dealing with plain matters of fact, many people should still give credence to the unwarranted statement that in Belgium excretal matters are sold at 1*l.* per head per annum, and that most Continental towns derive a more or less considerable income from the sale and utilization of human excreta. In the endeavour to correct the erroneous and exaggerated notions which not a few persons entertain with regard to the money value of human excrements, I have purposely confined myself to a statement of facts, which everyone may verify who will take the trouble to visit Continental towns and make inquiry into the manner in which human excreta are disposed of, and what is realized by the towns by their utilization. The practical conclusion to which an unbiassed inquirer into this subject will arrive is that, as far as the inhabitants of towns are concerned, human excreta are a nuisance, for the removal of which, in most towns, they have to pay something.

It can be shown, however, on other grounds, that the theoretical or calculated value of human excreta is nothing like 1*l.* per ton; and it may not be altogether unprofitable for me to point out what may be fairly regarded as their theoretical value. Their composition, I need hardly say, is subject to considerable variations; and, consequently, all calculations based upon analyses of these matters are liable to considerable fluctuations. Speaking generally, solid human excreta, as they leave the body, con-

tain about one-fourth of dry matter, and three-fourths of water. The dry matter contains about  $1\frac{1}{2}$  per cent. of nitrogen, and 1 per cent. of phosphoric acid.

According to Professor Way human fæces in a recent condition are stated to contain in 100 parts:—

Water .. .. .	75·00
*Organic matter .. .. .	22·13
Insoluble siliceous matter .. .. .	·37
Oxide of iron .. .. .	·13
Lime .. .. .	·43
Magnesia .. .. .	·38
Phosphoric acid .. .. .	1·07
Sulphuric acid .. .. .	·06
Potash .. .. .	·30
Soda .. .. .	·08
Chloride of sodium .. .. .	·05
	100·00
* Containing nitrogen .. .. .	1·50
Equal to ammonia .. .. .	1·82

If it were possible to dry fæces without loss in fertilizing matters, and without the addition of bulky material, they would, in a dry state, be a very valuable manure, for in that state they would contain:—

*Organic matter .. .. .	88·52
Insoluble siliceous matter .. .. .	1·48
Oxide of iron .. .. .	·54
Lime .. .. .	1·72
Magnesia .. .. .	1·55
Phosphoric acid .. .. .	4·27
Sulphuric acid .. .. .	·24
Potash .. .. .	1·19
Soda .. .. .	·31
Chloride of sodium .. .. .	·18
	100·00
* Containing nitrogen .. .. .	6·00
Equal to ammonia .. .. .	7·28

It appears from the preceding figures that, in a perfectly dry condition, 2 tons of solid human excreta are worth almost as much as 1 ton of Peruvian Guano; and it seems a great pity that a manure possessing such a fertilizing value should be wasted as at present it is in a great measure.

Still more valuable as a manure is human urine, for its principal constituent—urea—contains nearly 50 per cent. of nitrogen; and uric acid—an active constituent of urine—contains about 33 per cent. of nitrogen; and besides these nitrogenous organic matters, human urine contains a good deal of phosphoric acid.

Human urine has been analysed by Berzelius, Becquerel, and

other chemists; and, according to an analysis made by Professor Way, the solid matter which is obtained by its evaporation to a perfectly dry mass consists, in 100 parts, of:—

*Organic matter .. .. .	67.54
Insoluble siliceous matter .. .. .	.09
Oxide of iron .. .. .	.05
Lime .. .. .	.61
Magnesia .. .. .	.47
Phosphoric acid .. .. .	4.66
Sulphuric acid .. .. .	.46
Potash .. .. .	1.83
Chloride of potassium .. .. .	5.41
Chloride of sodium .. .. .	18.88
	100.00
* Containing nitrogen .. .. .	19.43
Equal to ammonia .. .. .	23.60

Unfortunately urine enters very rapidly into decomposition, giving rise to foul-smelling gaseous products of decomposition, and to volatile carbonate of ammonia; and, on keeping, loses much of its most valuable constituent. The collection and preservation of urine, in consequence, is attended with practical difficulties, which are greatly enhanced by the trouble and expense of getting rid of the large proportion of water which urine naturally contains. For these reasons, all attempts to collect urine and to obtain from it a solid manure by evaporation have hitherto proved failures in an economical point of view.

Fresh urine contains, on an average, only three per cent. of solid matter, and, according to Professor Way's analysis just quoted, consists of:—

Water .. .. .	97.000
*Organic matter .. .. .	2.026
Insoluble siliceous matter .. .. .	.003
Oxide of iron .. .. .	.002
Lime .. .. .	.018
Magnesia .. .. .	.014
Phosphoric acid .. .. .	.040
Sulphuric acid .. .. .	.014
Potash .. .. .	.055
Chloride of potassium .. .. .	.162
Chloride of sodium .. .. .	.566
	100.000
* Containing nitrogen .. .. .	.58
Equal to ammonia .. .. .	.71

Notwithstanding this large proportion of water, the amount of solid matter in the urine voided in a day is just about one-third greater than the amount of dry matter in the daily solid evacuations.

It is not easy to calculate with great precision what is the total



amount of fæces and urine which is produced by a mixed population of adults and children of both sexes; but it may be safely stated that the amount of dry matter in the solid and liquid excreta of a mixed population does not exceed 56 lbs. per head per annum, and that probably it is not more than 45 or 46 lbs. In some experiments which Professor Way made upon adults, he found that an individual voids in 24 hours about  $\frac{1}{4}$  lb. of fæces and 3 lbs. of urine. Assuming the preceding analysis fairly to represent the composition of the solid and liquid excreta of man, and each person of a population to produce  $\frac{1}{4}$  lb. of fæces and 3 lbs. of urine in 24 hours, we obtain in

4 ozs. of fæces 1 oz. of dry matter, or in round numbers nearly and in	Per annum. 23 lbs.
3 lbs. of urine $1\frac{1}{2}$ oz. of dry matter, or in round numbers nearly	34 lbs.

Thus the liquid excreta of man contain one-half more dry matter than the solid.

On calculating the amount of ammonia which will be produced on the decomposition of the dry matter of the solid and liquid excrements of each person per annum, we obtain from the

23 lbs. of dry matter contained in the solid excreta .. .. .	Ammonia. 1.60 lbs.
and in	
34 lbs. of dry matter contained in the liquid excreta .. .. .	8.12 lbs.
or altogether .. .. .	9.72 lbs.

In other words, five-sixths of the ammonia capable of being generated on the decomposition of human excreta is furnished by the urine. By a similar calculation I find that, according to the preceding data, each individual would furnish about  $5\frac{1}{2}$  lbs. of phosphates per annum. For simplicity's sake we may assume that each person of a population produces in the solid and liquid excreta 56 lbs. of dry matter per annum. These 56 lbs. produce in round numbers 10 lbs. of ammonia, and  $5\frac{1}{2}$  lbs. of phosphates.

In order to avoid the appearance of a wish to undervalue the intrinsic fertilizing value of human excreta, I would allow 9*d.* per lb. for ammonia, and 2*d.* per lb. for phosphates, and further 9*d.* for the money-value of the remaining constituents, which is rather more than the latter are really worth.

The excreta of each person of a population accordingly would be worth per annum 9*s.*, allowing

		<i>s.</i>	<i>d.</i>
For 10 lbs. of ammonia at 9 <i>d.</i> per lb. .. .. .	7	6	
„ $5\frac{1}{2}$ „ of phosphates at 2 <i>d.</i> per lb. .. .. .	0	11	
„ other matters .. .. .	0	7	
Total value of human excreta per head per annum .. .. .	9	0	

An elaborate inquiry, made some years ago by Mr. J. B. Lawes, into the composition of the excrements of a large mixed population, gave him results which he calculated as follows:—

TABLE showing the estimated constituents of HUMAN EXCRETA.

	Ounces per head per day. Average of both sexes and all ages.	Pounds per head per annum. Average of both sexes and all ages.
Total dry substance .. .. .	2·01	45·95
Mineral matter .. .. .	·45	10·34
Carbon .. .. .	·74	16·85
Nitrogen .. .. .	·35	7·94
Equal to Ammonia .. .. .	·42	9·64
Phosphates .. .. .	·20	4·58

The average amount of dry substance voided in the excrements of each individual of the population in twenty-four hours, it will be seen by these figures, is only two ounces; or equal to about 46 lbs. per annum. The two ounces of dry substance contain rather less than half an ounce of mineral matters, or about 10 lbs. per head per annum. About two-fifths of the mineral matters, or one-tenth of the total dry substance, consists of phosphates. Of the valuable constituent, nitrogen, there is an average of rather more than one-third of an ounce per day, or about 8 lbs. per annum; and these amounts of nitrogen are equal to ·45 of an ounce per day, or nearly 10 lbs. per annum of ammonia.

Mr. Lawes's estimate of the amount of dry matter in the excreta of a mixed population of both sexes and all ages differs but little from the preceding calculations, which are based on some direct experiments by Professor Way.

According to Mr. Lawes's estimate the money-value of the excreta per head per annum will be 8s. 10d., allowing

10 lbs. of ammonia at 9d. per lb.	.. .. .	7	6
4½ „ of phosphates 2d. per lb.	.. .. .	0	9
Other matters .. .. .	.. .. .	0	7
		8 10	

Bearing in mind that five-sixths of the total amount of ammonia in the solid and liquid excreta of man are furnished by the urine, and only one-sixth by the fæces, and how small is the proportion of the total urine that is passed at the same time, and that our domestic habits prevent the collection and absorption of

the whole of the urine, the intrinsic value of the fertilizing matters which can be practically recovered in Moule's earth-closets is probably not more than one-third of their value, or amounts to only 3s. for each person per annum. In order to recover these three shillings' worth of manuring matters a large quantity of earth has to be used in Moule's closet. Even assuming that the earth can be conveniently used in the closets three or four times in succession, it is not surprising that the earth-closet manure produced in the West Riding prison, Wakefield, such a small value as the preceding analyses have shown.

Mr. Moule states that three cart-loads of dry earth in one experiment served fifteen persons for half a year, being used five times over in that time. At that rate one ton would last  $2\frac{1}{2}$  persons for a year. Assuming that the total excreta of a man can be absorbed by the earth without loss, and that they possess an average value of 9s. per annum, each ton of earth used five times in the closet will be worth 22s. 6d.; but as, practically, about two-thirds of the fertilizing matters will be wasted in the urine, which cannot be recovered and absorbed by earth, the value of a ton of earth-closet manure used five times will only be about 7s. 6d.

If the whole of the liquid, as well as the solid, excretal matters were to be absorbed, probably not less than 9 to 10 lbs. of dry soil per head per day would be required, or about  $1\frac{1}{2}$  ton per head per annum. In the country the soil, it is true, may be used repeatedly in the closets; but in large towns the process of drying and sifting, and of storing for repeated use, present obstacles far too formidable to render it likely that the dry or earth-closet plan will ever come into general use, even supposing the earth-closet manure were twice or three times as valuable as the results of my analyses show it to be.

*Laboratory, 11, Salisbury-square, Fleet-street, E.C.,  
February 1872.*

---

VII.—*Interim Report on Veterinary Investigations.* By Professor  
JAMES BEART SIMONDS, Veterinary Inspector of the Society.

I. FEEDING EXPERIMENT WITH HARDON'S PATENT FEEDING  
CAKE.

This experiment, which may be designated No. 1, was undertaken in consequence of the Marquis of Exeter having lost a young bull, 10 months old, and also a valuable short-horn cow, under circumstances which led to the impression that the cake supplied to them was probably the immediate cause of death. Both the

animals had died very suddenly, while being fed for exhibition at the Society's annual show. Three pigs, also, which partook of some of the same cake, but only in small quantities, died at about the same time. All the animals presented the same morbid appearances on a post-mortem examination.

Neither a chemical nor microscopical examination led to the detection of anything of a poisonous nature in the specimens of cake examined. They were, however, of inferior quality, and appeared to have been greatly deteriorated by long keeping.

*May 6th, 1871.*—A healthy young heifer, about a year old, was selected for the experiment, and placed by herself in a loose box; water and hay, in ordinary quantities, being given to her, in addition to the suspected cake.

The quantity of cake supplied was 1 lb., and the same amount was allowed per diem for three consecutive days. On the 4th and 5th days, 2 lbs. each day were given; after which the animal partook of 4 lbs., for four days; 6 lbs., for six days; and 8 lbs., for two days; making a total of 75 lbs. in seventeen days.

On the evening of the fifth day of the experiment the heifer had an attack of indigestion, accompanied with tympany of the abdomen. This, however, passed off naturally, and by the following morning she appeared to be in her usual state of health. On the evening of the sixteenth day, after partaking of 8 lbs. of cake, she exhibited symptoms of serious illness; but towards evening she rallied a little. On the next morning, however, a relapse took place, and within little more than an hour she died. No treatment was adopted.

The post-mortem examination, which was made as early after death as possible, showed all the usual indications of blood-poisoning from deleterious food to be present, to a greater or less extent, in the several organs of the body. Venous congestion existed everywhere, the blood being black in colour and only imperfectly clotted. The abdomen contained a quantity of dark-coloured serous exudation. The rumen and other stomachs were distended with gaseous products, but their structure did not seem to have suffered. The intestines throughout presented an ecchymosed condition of the mucous membrane, the small ones containing, in addition, a large quantity of blood-coloured, semi-fluid exudation-matter. The spleen was filled to repletion with black blood, and the liver and kidneys were similarly affected. The lungs were also in a congested state; their structure, however, was normal. Extravasations of blood, small in amount, had taken place into the substance of the heart, as also beneath the lining membrane of the auricles and ventricles, particularly of the left ventricle.

On the result of the experiment being reported to the Marquis of Exeter, his Lordship communicated the circumstance to the Council of the Society, when some members appeared to think that the death of the animal was rather due to the quantity of the cake partaken of, than to anything deleterious which it might have contained. It was therefore determined to have recourse to some other experiments of a like kind with Hardon's cake, and to contrast these with experiments in feeding other young animals with large quantities of pure linseed cake. For this purpose two heifers—each about 10 months old—were selected, and three pigs, between three and four months old. A fresh supply of Hardon's cake was obtained for the experiments from the Marquis of Exeter.

## II.—SECOND EXPERIMENT WITH HARDON'S CAKE.

*July 17th, 1871. Heifer A.*—2 lbs. of cake, in addition to other food of the ordinary description, were given to this animal. It was readily partaken of. On the 18th, 19th, 20th, and 21st, the same quantity was allowed on each day. On the 22nd, 3 lbs. were given, and repeated for three consecutive days. During the four following days, 4 lbs. were allowed; and on the 29th and 30th, 5 lbs. On the 31st, 6 lbs. were given, and continued daily to August 3rd. On August 4th the quantity was increased to 7 lbs., and subsequently repeated day by day in this proportion throughout the month of August, and down to September 7th, when the experiment ceased.

During the entire time the animal did not appear to have its health impaired, beyond an occasional slight attack of indigestion. Its general condition, however, was but little improved; the inference being that the cake possessed only moderate feeding qualities.

## III.—LINSEED CAKE.

This cake was of best quality.

*July 17th. Heifer B.*—2 lbs. of cake were added to the food of this animal, which was of the same kind as that supplied to *Heifer A.* As in the other case, no increase was made in the quantity of the cake until July 22nd, when 3 lbs. were given and continued for the three following days. On the 26th the quantity was raised to 4 lbs., at which rate it was supplied for the four following days, when it was increased to 5 lbs. Two days subsequently it was raised to 6 lbs., and on August 4th to 7 lbs. Throughout the remaining part of the month, and down to September 7th, when this experiment also ceased, the animal was supplied with 7 lbs. daily. During the entire period the animal continued in perfect health. No loathing of food was at

any time produced, nor any disturbed condition of the bowels. It was observed that she grew rapidly, and maintained a thriving appearance.

The result of these experiments would seem to negative the opinion that the death of the heifer, the subject of the original experiment was due to the quantity of cake of which she partook, and that it most likely depended on that *special* lot having undergone some peculiar change, due probably to long-keeping. It has often been noticed that oil cake when old, is not merely deteriorated in feeding properties, but that it is really dangerous to the life of animals. The development of microscopic fungi has been assigned as the cause of this, and probably with much correctness; but in the present state of science it is scarcely safe to speak other than hypothetically on the point.\*

#### IV.—FEEDING PIGS WITH HARDON'S CAKE.

*July 19th, 1871.*—A three-months-old pig was supplied with  $\frac{1}{2}$  lb. of Hardon's cake, mixed with some wetted bran and corn—chiefly oats. This quantity was given daily for three days, when it was increased to 1 lb. In three days more it was again increased, the quantity now being  $1\frac{1}{2}$  lb.; at which rate it was continued down to July 29th, an occasional attempt being made to induce the animal to take a larger amount, but without success. Indeed, throughout the experiment, the animal showed very little relish for the cake, but would eat other food most readily.

On *July 29th* a second pig of the same age was placed with this one, and 3 lbs. of cake supplied to the two animals. It is necessary here to observe that this pig had been fed with another one, from July 21st to the 29th, on linseed cake, in addition to its ordinary food.

From *July 29th* to *August 7th* inclusive, the quantity of Hardon's cake was kept at 3 lbs. daily. It was now raised to 4 lbs. On the second day afterwards, the animals refused to take their food, excepting in small quantities, and did not consume more than 2 lbs. of the cake daily for the next four days; but otherwise their health did not seem to be affected. On *August 13th* they again partook of 3 lbs., and, within a day or two, of 4 lbs.; more than this, however, they could not be induced to eat. With a daily supply varying from 2 lbs. to 4 lbs., the experiment was continued down to *September 30th*, when it ceased.

As in the case of the heifer fed with Hardon's cake, these pigs

\* See the Annual Report of the Consulting Botanist, p. 211.—Ed.

did not much improve in condition, nor grow so well as might have been expected.

#### V.—FEEDING PIGS WITH LINSEED CAKE.

The cake used in this experiment was the same as that supplied to the *Heifer B.*

At the commencement of the experiment on July 21st, two pigs, 3 months old, were supplied with 2 lbs. of linseed cake, in addition to their other food. It was readily partaken of.

On July 25th the quantity was increased to 4 lbs., and continued for three days, when their appetite palled, and they would not take more than about half the quantity named.

On July 29th one of the animals was removed and placed with the pig which was being fed with Hardon's cake.\* Here it remained until the end of the experiment. The remaining pig was fed with linseed cake throughout the month of August and down to September 10th, when the use of the cake was discontinued. Its relish for the food was very variable; thus, for a day or two together it would readily eat 2 lbs., and sometimes 2½ lbs. of cake; while on other days it could scarcely be tempted to take half the quantity. Notwithstanding this, the animal thrived well, and at the end of the experiment was in excellent condition, contrasting favourably in this respect with the pigs fed on Hardon's cake.

These experiments of feeding pigs fully confirm the conclusion arrived at in the case of the heifer, as to the non-existence of anything positively poisonous in Hardon's cake. They also confirm the deduction that linseed cake given in the same proportion to the other food of the animals is a better feeding material than the samples of Hardon's cake supplied for the experiments.

#### VI.—DISEASE OF LAMBS.

With reference to the resolution of the Council, at its meeting on November 1st, 1871, relative to the serious losses which many farmers had sustained, especially in Lincolnshire, from disease among their lambs, I have to report that the investigation then ordered by the Council has been carried out as far as the period of the year would permit. The disease alluded to has long since attracted attention, and from time to time engaged the investigations of scientific men. Essentially the affection is due to the existence of matured parasitic worms within the bronchial tubes of the lamb, which ultimately produce structural disease of the lungs of the animal, by the myriads of young worms to which

\* See Experiment IV.

they as parents give birth. Of late years the disease has been largely on the increase, from causes which are but imperfectly understood, and which it would seem can only be elucidated by further investigation into the natural history of the worm. So far as the structure and means of direct propagation of the parasite are concerned, there appears to be but little to add to our present knowledge. The researches into its natural history, as far as they have gone, would, however, seem to lead to the conclusion that the young, or embryotic, worms are fitted for propagation of their species to a great extent rather out of, than within, the air passages of the animal.

Indeed it may hereafter be shown that it is essential to the ultimate sexual development of the worms, that in their immature condition they should become parasitic to some of the grasses, natural and artificial, on which the lambs are fed at the time of being attacked. With a view to assist in this part of the inquiry, I have asked for and received portions of turf cut from meadows on which diseased lambs had been pastured. These turf-cuttings have been supplied by two members of the Lincolnshire Committee, and will, as soon as the season is more advanced, be subjected to a searching microscopical examination.

With the same object in view, a series of questions—see Addendum—has been drawn up and forwarded to the Secretary of the Lincolnshire Society for circulation among the members. In due time they will be answered and returned to me for analysis and deduction.

It may further be remarked that, as negative evidence may not unlikely prove of great value in the inquiry, I have repeated an experiment—some years since adopted by me—namely, that of conveying the ova of the worm, and also embryotic worms obtained from the lungs, directly into the air passages of a lamb.

On former occasions, experiments of the kind have invariably had a negative result; and the present one does not promise any other, as the lamb—the subject of the experiment—appears to continue in perfect health. The introduction of the ova and young worms has been twice had recourse to; first, on October 24th; and secondly, on November 17th, 1871. An inquiry of this kind must necessarily occupy much time and attention and probably the carrying out of numerous experiments on selected farms, as well as within an institution like the Royal Veterinary College. The subject, however, will receive every attention, and no time will be lost in its further investigation.

*Feb. 1st, 1872.*



## [Addendum.]

ROYAL AGRICULTURAL SOCIETY OF ENGLAND.

## LAMB DISEASE.

LIST OF QUERIES prepared by Professor Simonds, to which an early reply is respectfully solicited by the Lamb Disease Committee of the Lincolnshire Agricultural Society.

1. How long has the Farm been in your occupation?
2. What are the general characters of the soil and subsoil?
3. What is the relative proportion of Meadow to Arable Land?
4. Is the Farm wet, or dry; partially, or wholly drained?
5. State the system of husbandry with regard to the rotation of Crops.
6. Is the Meadow Land liable to flood?
7. Are the Meadows mown and fed in alternate years, or mown yearly and the after-grass fed with sheep?
8. Do sheep contract rot on the Farm?
9. For how many years have you been familiar with the "lung-worm disease" on your Farm?
10. How many breeding Ewes are kept?
11. What is the general management of the Ewes, especially as to varieties of food supplied to them from the time they are put to the ram to the period of lambing?
12. State the system which is adopted with regard to the other sheep on the farm, and especially with reference to the lambs being sold either fat or as store stock?
13. What custom prevails with regard to stocking the farm with sheep either for breeding or feeding?
14. At what date are the lambs dropped, and when weaned, as a rule?
15. After lambing how are the Ewes and Lambs fed and managed until weaning-time?
16. Have the lambs ever been known to be diseased if, after being weaned, they have been kept *exclusively* on permanent pasture down to the end of the year?
17. If affected on permanent pasture, has the custom been to mow such pasture and feed the after-grass, or to feed throughout the summer?
18. At what period of the year have the first indications of the lambs being unhealthy been observed?

19. Has the state of the weather influenced the attacks, and, if so, in what manner?
20. Has the disease prevailed more or less every year, or have there been years of freedom from it?
21. If the disease has been on the increase of late years, to what cause is it attributed?
22. When the lambs have gone apparently healthy from permanent pasture to rape, mustard, or other green crop of that year's produce, have they suffered from the disease?
23. On what evidence has reliance been chiefly placed that the lambs, which subsequently showed symptoms of the disease, were in a perfectly healthy condition when removed from permanent pasture to crops not previously fed with sheep?
24. Supposing layers are fed with sheep and allowed to stand over for feeding again in the following year, have the lambs pastured thereon been early attacked or not?
25. Has it been observed that lambs which are grazed during the summer on seeds, that had not been previously stocked with sheep, contract the disease?
26. When the lambs are unmistakably diseased, on what part of the farm and on what food in particular, have they been afterwards kept?
27. What symptoms do you deem to be characteristic of the disease?
28. How long a time usually elapses between the first indications of disease and death?
29. Does scouring—diarrhœa—exist in all cases before death?
30. What are the percentages of deaths over recoveries, or *vice versa*?
31. Have you found any means by which the disease is kept in check or even partially prevented?
32. Are any calves reared on the farm, and, if so, do they suffer from the disease called "hoose" or "husk"?
33. Have apparently healthy lambs, which had been reared with those that were diseased, been kept as stock-sheep for use during the following or succeeding years?

Signed,

\_\_\_\_\_

A Member of the Lincolnshire  
Agricultural Society.

Date,      March, 1872.

This list should be returned to the Secretary of the Lincolnshire Agricultural Society *before the 25th of March.*

---

VIII.—*First Report of the Consulting Botanist.*

IN presenting my first Report I might express regret that my services have been made use of to so small an extent, were it not that the appointment of a consulting botanist, with the view of applying, through his advice, botanical science to agricultural problems, is so new a proceeding that some time must elapse before the members of the Society realise the nature and value of the benefits that may thus be obtained.

Some cases of interest, however, have been submitted to me which deserve to be recorded, and one at least to be described at some length.

I have examined a specimen of feeding cake, composed of a mixture of various husks and seeds, which had proved injurious to the cattle fed upon it. I failed to detect any ingredient which was likely to produce the effects ascribed to the use of the cake. When submitted to investigation it was found to have been attacked by a fungus, the mycelium of which had penetrated the cake in every direction. This, in the course of time, developed into its fruiting state, and I was enabled to determine that it was only a species of mould (*Penicillium*). The mycelium of mould is sometimes quite innocuous, as, for example, in the blue and red mould of cheese. At other times it acts as a dangerous poison, either from its own presence in the food which it attacks, or, more probably, from the changes which it induces in the food substance. It is thus probable that the storing of cake in damp places, where the very minute spores of fungi abound, and where the most favourable conditions exist for their germination, may induce the attack of a fungus which may completely alter the character of the cake.

In the early autumn I received specimens of ear-cockle from North Surrey, where this disease, unknown to the sender, was said to be very prevalent. The black roundish grain is found, on examination, to be full of small worms, the well known *Vibris Tritici* of Bauer and Banks ('Phil. Trans.,' 1823, p. 1, plates i. ii.), and *Tylenchus Tritici*, Bastian ('Linn. Trans.,' 1865, p. 126, plate x., figs. 112-114). These little eel-like worms possess a remarkable tenacity of life, being revived, on the application of moisture, after they have been dried up for years. The origin of this malady is hid in obscurity. It is very local and intermittent in its appearance. A series of careful investigations, when it does occur, as to the physical conditions of the season, and of the locality, would be of great importance.

The most important investigation which I have made is into a remarkable disease which attacked a field of wheat belonging

to H. J. Seels, Esq., of The Hall, Wainfleet. In June of this year he observed that many of the ears were in a weak and sickly condition, in some cases somewhat discoloured; and in all the attacked specimens the process of maturing the grain had entirely stopped. In examining the plants, he found that a brown discoloration existed in every one at the base of the straw. The specimens forwarded to me were all discoloured between the first and second joints from the root; and, on examining this portion of the plant with the microscope, I discovered that the soft cellular tissues of the stem were everywhere penetrated, and more or less completely destroyed by the mycelium of a fungus. The brown colour on the stem increased in intensity with the development of the fungus. Very soon the parasite so injured the tissues of the plant that all vital connexion between the roots and the upper part of the wheat was cut off; the circulation of the sap was stopped, the nourishment was wanting for the grain, and this remained in an immature condition. After my examination I reported to Mr. Seels the nature of the malady, and suggested that nothing could be done to save the crop; but that the heavy and persistent rains, which were obviously the cause of the disease, might to some extent be the means of recovering the field from it. I had hoped that sufficient moisture might be absorbed by the leaves and stems from the rain to enable the living plants to send down new roots and re-establish their connexion with the soil. I am glad to report that this was really the result, and that to some extent the injury was not so serious as at first it threatened to be.

In investigating the history of this disease I ascertained that it had suddenly made its appearance (in the year 1851) in France, in fields of wheat extending over a large area, and that from its attacking the foot of the wheat stalk it had received the name of "pictin." In 1854 the Rev. M. J. Berkeley incidentally referred to it in a review in the 'Gardener's Chronicle,' as having come under his notice in this country, but no detailed account has hitherto appeared of its nature, or of its occurrence in England. I have, therefore, appended to this Report, an account of the disease, with woodcuts, representing its aspects to the naked eye, and the appearance of the parasite when examined under the microscope. There is the more necessity for calling the attention of agriculturists to this disease, as the fungus has not yet been found in a condition fit for its complete investigation; and until the botanist can ascertain the precise character and habit of the plant, he can suggest only vague remedies for the cure of the malady.

(Signed)

WILLIAM CARRUTHERS, F.R.S., F.L.S.

---

IX.—*On Straw-Blight, a Disease of Wheat-Straw.* By W. CARRUTHERS, F.R.S., F.L.S., Consulting Botanist.

The first indication of this disease is the occurrence of small brownish spots on the surface of the straw towards its base, generally below the first joint from the root, or between that and the second, or sometimes as high as between the second and the third joints. These spots become darker in colour and increase in size, becoming of an irregularly roundish or oblong form, and ultimately becoming confluent.

A careful examination of the stem shows that they are not superficial, but depend on changes in the interior of the stem. On applying the microscope to prepared sections, it is found that the solid part of the stem, below the coloured spots, is penetrated by the branching and con-jointed mycelium of a fungus, similar to that which has produced such havoc to the potato crop for so many years. The filaments of the mycelium are extremely fine, repeatedly branch, and frequently anastomose. Only here and there a slight indication of joints, or horizontal partitions, appear. This mycelium passes

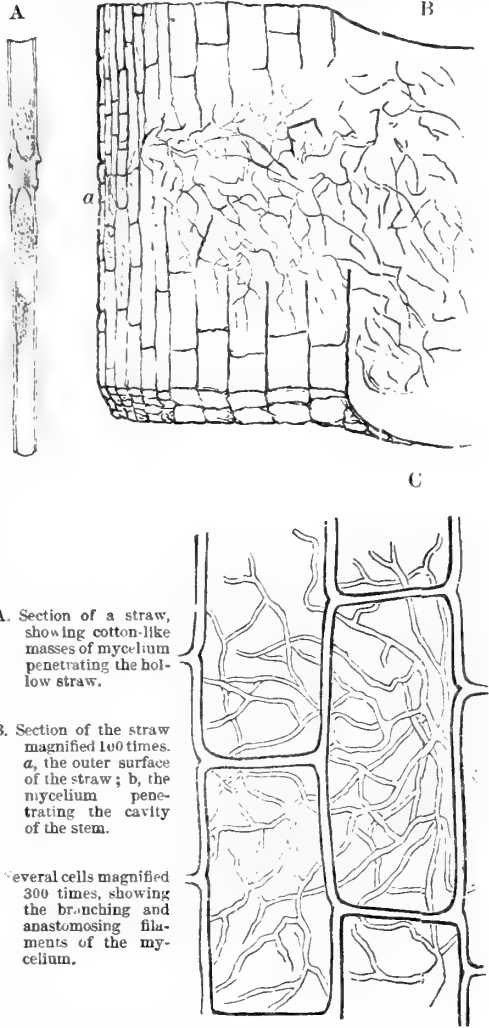

A. Section of a straw, showing cotton-like masses of mycelium penetrating the hollow straw.

B. Section of the straw magnified 100 times. *a*, the outer surface of the straw; *b*, the mycelium penetrating the cavity of the stem.

C. Several cells magnified 300 times, showing the branching and anastomosing filaments of the mycelium.

are extremely fine, repeatedly branch, and frequently anastomose. Only here and there a slight indication of joints, or horizontal partitions, appear. This mycelium passes

through the intercellular spaces, and penetrates the cellular tissues themselves in every direction (Figs. B, C), more or less breaking them up from its rapid increase, and ultimately passing into the hollow interior (Fig. B, *b*), which it fills with masses of delicate, matted, cotton-like threads (Fig. A). As soon as the straw is attacked, the vital action of the plant is affected; and as the fungus develops, it completely stops the circulation of the sap, by cutting off the connection between the roots and the foliage. If the disease attacks the wheat before the period of flowering, the plants are hopelessly destroyed. The disease, however, appears generally to show itself at a later stage of the life of the plant, when the ear is beginning to fill; and then, if there be sufficient food and vigour in the healthy upper part of the wheat to enable it to send out fresh roots from the lowest healthy joint, and to re-connect the living part with the earth, the growth of the spike which has been interrupted will be renewed, and the ears, though never filling completely, will nevertheless yield a partial crop. Even at the best, the ears of diseased stems, from the direction of the food of the plant to the formation of new roots, and from the diminished supply of food even when the new roots are in active operation, remain small, and when dry, are shrivelled and wrinkled, from being only imperfectly filled. Indeed the farmer generally detects the occurrence of this pest among his crops by observing the sickly aspect of the spike.

No observer has yet noticed the fructification of this fungus, and as the classification of this group of plants is entirely based on the organs of reproduction, it is impossible to determine without them the genus, or even the group, to which this mycelium belongs.

Duchartre has detected on plants affected by straw-blight several species of other parasitic fungi, such as *Cladosporium herbarum*, Link, *Septoria Triticis*, Desmazieres, and *Erysiphe graminis*, De Candolle. It is, however, certain that the mycelium of straw-blight does not belong to any of these known species.

It was observed in 1851 that both barley and rye, as well as wheat, were attacked by this straw-blight in the valley of Villepreux, in France.

The disease has been noticed in Belgium, as well as in France and England. It has been very irregular in its appearance, having been absent from a locality for many years, and then appearing and producing serious injury to the crops. It is estimated that in some districts in France it reduced the yield of grain in 1851-1852 to one half; but the injury is seldom so severe as this, being generally from one-twentieth to one fiftieth.

The nature of the soil has nothing to do with the disease, as

it has been noticed equally on arenaceous, argillaceous, and calcareous soils. But its appearance has always been associated with long-continued rains. The appearance of the disease in England during the past year (1871) was no doubt due to the very damp early summer. There is no hope of curing the malady when it appears, but there can be no doubt that thorough drainage would either completely prevent it, or greatly modify its intensity when it does appear.

---

X.—*Annual Report of the Consulting Chemist for 1871.*

IN my last Annual Report I showed that the analytical work for Members of the Society in 1870 had increased in an unprecedented degree, as many as 580 analyses having been referred to me in that year, or 115 more than I had sent out in 1869.

In consequence of this increased work I found it necessary to engage the services of an additional assistant. Notwithstanding his aid in despatching with promptitude analyses and reports to our members, the samples of manures, soils, oilcakes, &c., which were sent to the Laboratory became so numerous in the spring months of 1871 that at times I was quite overwhelmed with analytical work, and was obliged to make a further addition to my staff of chemical assistants.

In order to give undivided attention to the yearly increasing demand upon my services, and to be able personally to superintend the work of my assistants, I have found it necessary to decline all applications for instruction in analytical chemistry, and to refuse the admission into my Laboratory of pupils or voluntary assistants; and I take this opportunity of mentioning that I am assisted in the Laboratory work only by a staff of well-trained, paid assistants, several of whom have been in my service for many years.

During the period from December 1870 to December 1871, as many as 730 analyses have been referred to me by Members of the Society, being the unprecedented increase of 150 analyses over the number sent out in 1870.

It will be satisfactory to the Council, and specially gratifying to the Chemical Committee, to recognize in these figures a direct proof that the publication of the periodical Reports of the Chemical Committee has borne good fruit. A comparison of the subjoined returns for the last five years shows that the analytical work has been more than doubled in five years, whereas previous to 1868 it remained pretty stationary, averaging about 330 analyses yearly.

*Analysis made for Members of the Royal Agricultural Society.*

				Increase over preceding years.	Increase of 1871 over 1867.
In 1867	..	..	341	...	...
„ 1868	..	..	432	...	91
„ 1869	..	..	465	...	33
„ 1870	..	..	580	...	115
„ 1871	..	..	730	...	150
					389

The appended summary shows that a large number of feeding cakes and artificial manures were examined by me in 1871.

Some of the samples of manures were found all but worthless and others of a very inferior character; but, as I have already directed attention to special cases in my quarterly reports, I need not dwell, on the present occasion, on the subject of the adulteration of manures. Suffice it to say, that purchasers have still cause to be on their guard in buying manures, the composition and fertilizing qualities of which are not guaranteed by analysis.

The habit of buying superphosphate of a guaranteed strength is gaining ground more and more; and it is well that it should be so, for it is quite impossible to form even an approximate estimate of the value of a superphosphate or a similar artificial manure by any other means than by a quantitative chemical examination.

I would specially recommend all who buy mineral superphosphate, to obtain a guarantee from the maker or dealer, stating the amount of soluble phosphate of lime which he is prepared to supply at a given price, and to stipulate for a deduction to be made if the bulk, on delivery, does not contain the guaranteed percentage of soluble phosphate.

Bones have become scarce and dear of late years, and hence few manure manufacturers supply genuine dissolved bones; that is, a fertilizer consisting of nothing else but bone-dust made partially soluble by acid.

According to my experience, nine-tenths of commercial dissolved bones are mixtures of mineral superphosphate with more or less bone-dust, partially acted upon by the acid of the superphosphate. Such mixtures should not be sold as dissolved bones, but under a name which expresses more fairly the real character of the article. In buying bone-superphosphate or dissolved bones, the purchaser may reasonably expect that any insoluble phosphate in the manure should be present in the shape of raw or boiled bone, and not as bone-ash, or in the shape of coprolite powder, or any other form of mineral phosphate, and demand a guarantee accordingly. In the shape of bone, partially acted upon by acid, insoluble phosphate of lime has a high fertilizing value, whereas it is of little or no practical utility to the farmers if it occurs in a superphosphate in the state of a



mineral phosphate. It is the special business of the manure manufacturer to render these mineral phosphates soluble and efficacious, and if he neglects to do this, the consumer should not be called upon to pay for constituents which, in an insoluble state, are of little or no value to him.

Most of the samples of bone-dust analysed by me in 1871 were pure and of good quality; some, however, were too damp; and others, sold as raw bone, were mere mixtures of new and boiled bones (refuse bones of glue-makers).

Boiled bones, being the refuse bones of glue-makers, are more energetic in their immediate effects upon vegetation than raw bone-dust, and are well suited for grass land; but they are not so lasting in their effects. As they yield only from  $1\frac{3}{4}$  to 2 per cent. of ammonia, whilst fresh bones yield fully  $4\frac{1}{2}$  per cent., boiled, or glue-maker's refuse bones, fetch a lower price than fresh bone-dust; and for that reason the two kinds should be sold separately, under their right names.

The price of sulphate of ammonia has risen during the last year very much. Its present price is 21*l.* to 22*l.* per ton, and it is to be feared that this high price will be an inducement to unprincipled dealers to sell this valuable fertilizer in a more or less adulterated condition. I would therefore state that first quality sulphate of ammonia should contain 25 per cent. of ammonia, and second quality not less than 23 per cent.; and I recommend that in all purchases the percentage of ammonia in the sulphate should be guaranteed by the vendor.

In last year's Report I expressed the hope that the supply of guano from the Guanape Islands would turn out to be of a quality superior to that of some of the samples which were brought under my notice, and which I found very damp, lumpy, and comparatively poor in ammonia. This hope, I regret to say, has not been fulfilled, for about three-fourths of the 78 samples of guano analysed by me in 1871 were Guanape guano, and the majority of them were very damp, lumpy, and altogether in a condition unfit for direct application to the land. In most of the samples I found from 22 to 24 per cent. of water, and in some even a higher percentage, and only a few yielded more than 11 per cent. of ammonia, whilst in a good many I found only from 8 to 10 per cent., and in some even less than 7 per cent. of ammonia. In consequence of the variable composition of Guanape guano, and the wet, unmanageable condition in which much of it has been delivered to the farmer, Peruvian guano has lost credit with the farmers of England. In former years such wet and inferior guanos were sold as sea-damaged, at prices varying with the composition and intrinsic value of the cargo. During the past season Guanape Island guano, no matter of what quality, was all sold by the

Peruvian Government agents at one uniform price; and as the importers refused that samples should be taken and the quality of the various cargoes ascertained before the purchase was made, it is not surprising that the sales of Peruvian guano in England have fallen off very much indeed during the last twelve months. Many agriculturists have justly lost faith in the superiority of Peruvian guano over other artificial manures; and, in my judgment, they are fully justified in declining to buy guano on terms which do not offer a reasonable guarantee that they receive a fair equivalent for their money.

The whole guano business is at present in a very unsatisfactory state, and as the contract between the Peruvian Government and their present agents in this country terminates next August (1872), any arrangements which the new contractors, Messrs. Dreyfus, Frères, and Co., of Paris, or their agents in London, Messrs. J. Hy. Schröder and Co., may make hereafter, are not in operation at present. There is, however, every reason to believe that the Peruvian guano which will be offered in future, when the Government sales in this country are undertaken by the new contractors, will be of a very superior character.

If the Peruvian Government agents in this country are in a position to reassure the public that their importations will consist of guano of high quality, there can be no doubt that the sales will soon become as extensive as they ever were. Both in the interest of the importers and the consumers, it is to be hoped that in future no guano will be brought into the market and sold as best Peruvian guano, which, like many samples of Guanape Island guano examined by me in 1871, is wet, pasty, and comparatively poor in ammonia; but that all the guano which is offered for sale as best Peruvian really possesses the superior properties which characterised the former and now exhausted Chincha Islands supplies.

The importation of a dry light-brown coloured guano, rich in ammonia, is of vital importance to the agriculturists of all countries; for whilst phosphatic fertilizers are constantly being discovered, and no fears exist that the supplies of phosphatic rocks and minerals which are found in enormous quantities in various parts of the globe will ever be exhausted, the sources from which ammonia can be obtained are limited. Hitherto Peruvian guano has been one of the main sources for the artificial supply of ammonia, with which the farmer enriched his fields; and, considering the present high price of sulphate of ammonia and all nitrogenous fertilizing matters, the farmers of England unquestionably will welcome and highly appreciate the importation of guano possessing the characteristics of that of the Chincha Islands.

It affords me, therefore, much gratification to report that the

Peruvian Government agents for France and Germany, into whose hands the sales for England will fall next August, if not earlier, at the present time import a first-class guano from the Ballestas Islands, which are situated in close proximity to the Chinchas. Excellent cargoes have been shipped already to Hamburg and to Rotterdam, as will be seen by the following analyses which I have lately made of fairly drawn whole cargo samples which were sent to me from Germany and Holland for examination (see next page).

All the seventeen cargoes of Ballestas Island guano examined by me were dry, of light-brown colour, and not distinguishable in appearance from Chincha Islands guano.

A glance at the following Table shows that all the cargoes contained but a small quantity of insoluble siliceous matter; and that, with one exception, the sixteen remaining cargoes yielded over  $14\frac{1}{2}$  per cent. of ammonia.

Three of the cargoes, it will be seen, yielded from 16 to  $16\frac{1}{2}$  per cent. of ammonia; nine from  $15\frac{1}{4}$  to  $15\frac{3}{4}$  per cent., and four from  $14\frac{1}{2}$  to  $14\frac{3}{4}$  per cent. of ammonia.

It is difficult to estimate with any degree of accuracy the quantity of this guano likely to be available for shipment, but the deposits are considerable and, to all appearance, they will furnish an abundant supply for a good many years; and, as there are other islands on the Peruvian coast not yet worked, yielding guano of a similar high quality, the British farmer may look for large importations of a similar excellence.

Amongst the large number of feeding cakes examined by me in the past season I found some utterly unfit for feeding purposes, and not a few linseed cakes, sold as pure, adulterated with earth-nut cake, bran, and similar cheap feeding materials.

Green German rape-cake is generally considered much superior to ordinary rape-cake, inasmuch as it does not usually contain any appreciable quantity of wild mustard-seed, which often occurs in common rape-cake, and in such large proportions that the cake becomes unfit for feeding purposes. Quite recently, however, I examined two samples of green rape-cake which, as far as appearance went, had all the characteristics of a superior German rape or Rübsen-cake, but which nevertheless contained so much mustard that the cake could not be given with safety to animals. In a report on the samples of feeding cakes submitted to me during the past twelve months, I should not omit to state that five or six cases have been reported to me in which decorticated cotton-cake was alleged to have caused the death of sheep and lambs, and to have seriously injured the health of others. The examination, however, of the cotton-cakes which were supposed to have done the mischief, showed that they did not con-

## ANALYSES OF SAMPLES FROM VARIOUS CARGOES OF GUANO IMPORTED FROM THE BALLESTAS ISLANDS.

	Isaac Hall.	Dominicio.	Palmas.	Fairy Bell.	Clevra.	General Shepley.
Moisture .. .. .	18·04	18·06	18·93	19·19	18·86	17·01
*Organic matter and ammonia salts .. }	49·22	46·81	47·97	48·19	45·57	50·35
Phosphates .. ..	22·18	23·20	21·95	20·69	23·29	22·01
†Alkaline salts, &c. ..	8·40	9·49	9·40	9·40	10·45	9·28
Silica .. .. .	2·16	2·44	1·75	2·53	1·83	1·35
	100·00	100·00	100·00	100·00	100·00	100·00
*Containing nitrogen.. ..	12·91	12·27	12·99	13·60	12·14	13·26
Equal to ammonia .. ..	15·67	14·89	15·77	16·51	14·74	16·10
‡Containing phosphoric acid	2·82	2·70	2·49	2·47	3·07	2·74
Equal to tribasic phosphate of lime .. .. . }	6·16	5·89	5·43	5·39	6·70	5·98

	British Empire.	Thomas Lord.	Crusader.	Squando.	Detroit.	True Briton.
Moisture .. .. .	16·67	17·77	18·51	13·48	17·01	17·70
‡Organic matter and ammonia salts .. }	49·61	49·04	49·11	45·56	51·01	49·10
Phosphates .. ..	21·26	21·69	21·97	25·37	22·65	21·76
§Alkaline salts, &c. ..	11·17	9·86	8·94	12·75	8·04	9·85
Silica .. .. .	1·29	1·64	1·47	2·84	1·29	1·59
	100·00	100·00	100·00	100·00	100·00	100·00
‡Containing nitrogen.. ..	13·20	13·60	12·73	10·75	12·98	11·93
Equal to ammonia .. ..	16·03	16·51	15·46	13·05	15·76	14·54
§Containing phosphoric acid	2·95	2·31	2·26	3·25	2·90	2·39
Equal to tribasic phosphate of lime .. .. . }	6·44	5·04	4·93	7·09	6·33	5·21

	Elize Mathilde.	Satellite.	Northumbria.	Lady Belleau.	Hertha.
Moisture .. .. .	17·93	16·77	16·60	18·18	19·28
Organic matter and ammonia salts .. }	48·73	50·71	48·03	48·83	48·05
Phosphates .. ..	20·63	21·74	22·97	22·68	21·72
¶Alkaline salts, &c. ..	11·32	9·09	10·16	8·87	9·61
Silica .. .. .	1·39	1·69	2·24	1·44	1·34
	100·00	100·00	100·00	100·00	100·00
Containing nitrogen.. ..	12·59	12·78	12·52	12·97	12·26
Equal to ammonia .. ..	15·29	15·51	15·20	15·75	14·88
¶Containing phosphoric acid	2·96	2·10	2·32	2·36	2·42
Equal to tribasic phosphate of lime .. .. . }	6·46	4·58	5·06	5·15	5·28

tain any poisonous ingredient, and that several of the specimens were cakes of the finest quality ever submitted to me for examination. These cakes contained over 40 per cent. of albuminous com-

pounds, and, as they were as fresh and palatable as a nut, I have little doubt that the animals who suffered in health partook too freely of them, and were unable properly to digest the large proportion of nitrogenous compounds which first quality decorticated cotton-cake contains. In point of fact, good decorticated cotton-cake is too rich in nitrogenous matters to suit well by itself the constitution of herbivorous animals, and I would therefore strongly recommend its being mixed with Indian corn, or a similar starchy food comparatively poor in nitrogenous matters.

Other specimens of decorticated cotton-cake, reported to me as having done injury to stock, I found very hard pressed; and on further examination I detected in them a great many hard lumps of consolidated cake, varying in size from a pea to a large nut. These hard lumps, it appears to me, are produced in pressing the cake. With a view of obtaining as much oil from decorticated cotton-seed as possible, the latter is at first pressed cold; the cold-pressed cake is then broken up and ground into meal, heat being applied at the same time, and in order to prevent the cake becoming roasted, some water is sprinkled upon the broken cake when it is ground a second time. If this operation is carelessly done, the water forms small lumps with some of the pounded cake, and is rendered very indigestible.

In the next place, I have to report that of the 36 samples of drinking waters sent to me for examination by Members of the Society, I found a good many largely contaminated with sewage, yard-drainage, and similar prejudicial liquids. Abundant evidence has shown me that the water with which country houses and villages is supplied is frequently largely impregnated with animal refuse products, and is unquestionably injurious to the health of those who drink it. By way of illustration, I would direct attention to the following analyses of two samples of water; one sent for examination from a place in Warwickshire, the other from Northamptonshire.

The Warwickshire water was found to contain, in the imperial gallon:—

	Grains.	Constituents Combined.	Grains.
Organic and volatile matters (loss on heating) .. ..	6·80	Organic matter, including of oxydisable matter .. ..	6·80
Tribasic phosphate of lime .. ..	1·25	Phosphate of lime .. ..	1·25
Lime .. ..	12·76	Sulphate of lime .. ..	18·95
Magnesia .. ..	9·11	Carbonate of lime .. ..	8·86
Chlorine .. ..	10·49	Carbonate of magnesia .. ..	5·75
Sulphuric acid .. ..	11·15	Nitrate of magnesia .. ..	23·59
Nitric acid .. ..	17·22	Chloride of sodium .. ..	17·28
Alkalies and Carbonic acid .. ..	25·72	Alkaline carbonates .. ..	12·02
Soluble silica .. ..	1·20	Soluble silica .. ..	1·20
	95·70		95·70

This water, it will be seen, contained as much as 95·7 grains of solid matter in the imperial gallon, and a considerable proportion of this solid matter consisted of nitrates, common salt, and other saline constituents which are not usually found in large proportions in wholesome drinking waters. The water, moreover, was discoloured, and contained a good deal of soluble organic matter of animal origin.

The water from Northamptonshire was equally unfit for drinking purposes, as will be seen by the following analytical results.

An imperial gallon, on evaporation, left 121·5 grains of solid residue, containing :—

	Grains.	Constituents Combined.	Grains.
Organic and volatile matters (loss on heating) .. ..	6·90	Organic and volatile matters, including 1·344 oxydisable organic matter .. .. .	5·19
Oxide of iron, &c. .. ..	.. ..		
Lime .. .. .	26·48	Carbonate of lime .. .. .	9·43
Magnesia .. .. .	6·49	Sulphate of lime .. .. .	41·67
Chlorine .. .. .	17·33	Nitrate of lime .. .. .	11·84
Sulphuric acid .. .. .	24·51	Nitrate of magnesia .. ..	24·01
Nitric acid .. .. .	25·32	Chloride of sodium .. .. .	28·56
Carbonic acid and alkalies ..	13·67	Soluble silica .. .. .	·80
Soluble silica .. .. .	·80		
	<hr/> 121·50		<hr/> 121·50

If it be borne in mind that good and wholesome drinking waters do not contain any considerable amount of organic impurities, and on evaporation seldom leave more than 25 to 35 grains of solid matter, I need hardly remark that a water which contained as much as 25 grains of nitric acid in the gallon, as well as much soluble organic matter, and altogether left 121½ grains of solid matter on evaporation, must be regarded as decidedly unwholesome and unfit for domestic use.

The following are the papers contributed by me to the pages of the February and August numbers of the 'Journal' for 1871 :—

1. On Sugar-beets and Beet-root Distillation.
2. On the best mode of preparing Straw-chaff for Feeding Purposes.
3. On Field Experiments on Root Crops.
4. On the Composition and Nutritive Value of the prickly Comfrey (*Symphytum aspernum*).
5. Quarterly and Annual Reports.

In conclusion, I may observe that I have examined a considerable number of sugar-beets, and that whilst I have found in some crops as much as 12 per cent. of sugar, the sugar-beet crops on the whole are poorer in sugar this season than they were last year.

Analyses made for Members of the Royal Agricultural Society, December 1870 to December 1871.

Guanos .. .. .	78
Superphosphates, dissolved bones, wheat manures, and similar artificial manures .. .. .	202
Bone-dust .. .. .	36
Refuse manures .. .. .	31
Nitrate of soda, sulphate of ammonia, and potash salts ..	31
Marls, limestones, fireclays, and other minerals .. ..	20
Soils .. .. .	44
Oilcakes .. .. .	212
Feeding meals .. .. .	24
Vegetable productions .. .. .	12
Waters .. .. .	36
Examinations for poisons .. .. .	4
Total .. .. .	730

(Signed) AUGUSTUS VOELCKER, F.R.S.

XI.—Quarterly Report of the Chemical Committee.

DECEMBER.

1. DR. VOELCKER reports the analyses of three samples of guano sent to him by Mr. H. W. Hollis, Estate Offices, Keele, near Newcastle, Staffordshire, in May, 1871. These three guanos were found to have the following composition :—

	No. 1.	No. 2.	No. 3.
Moisture .. .. .	7·56	7·02	15·55
*Organic matter and ammoniacal salts ..	21·67	21·91	40·25
Phosphate of Lime .. .. .	14·85	15·34	23·06
Carbonate of lime .. .. .	9·67	10·31	..
Alkaline salts .. .. .	8·08	7·20	6·06
Insoluble siliceous matter .. .. .	38·17	38·22	15·08
	100·00	100·00	100·00
*Containing nitrogen .. .. .	4·56	5·01	9·55
Equal to ammonia .. .. .	5·54	6·07	11·59

The prices of the three samples were—No. 1, 14*l.*; No. 2, 12*l.* 15*s.*; No. 3, 16*l.*

The first and second samples are adulterated, for both contain as much as 38 per cent. of sand, and about 10 per cent. of carbonate of lime (chalk); and the one yields only  $5\frac{1}{2}$  per cent. of ammonia, and the other 6 per cent. of ammonia, in round numbers.

The composition of these two samples is pretty much the same, the second being slightly better than the first, although it was sold at 25s. less money per ton than No. 1. The third sample is genuine guano, but of an inferior character, inasmuch as it contained 15 per cent. of insoluble matter, and yielded only  $11\frac{1}{2}$  per cent. of ammonia. Such guano is not worth 16*l.* a ton, and the adulterated samples, No. 1 and No. 2, sold respectively at 14*l.* a ton and 12*l.* 15s., were not worth more than 8*l.* a ton.

Dr. Voelcker wrote for the names of the sellers of these guanos, but obtained no reply in answer to his inquiries.

2. A sample of artificial manure, sent by Mr. J. Reeve, Snetterton Hall, Thetford, on analysis was found to have the following composition:—

Moisture .. .. .	12·53
*Organic matter .. .. .	25·06
Oxide of iron and alumina .. .. .	10·35
Phosphate of lime .. .. .	1·70
Carbonate and sulphate of lime .. .. .	16·74
Magnesia and alkaline salts .. .. .	2·01
Insoluble siliceous matter (sand) .. .. .	30·61
	<hr/>
	100·00
	<hr/>

* Containing nitrogen .. .. .	87
Equal to ammonia .. .. .	1·05

This artificial manure, it will be seen, contained only  $1\frac{3}{4}$  per cent. of phosphate of lime, and yielded only 1 per cent. of ammonia. It contained  $30\frac{1}{2}$  per cent. of sand, and a large proportion of oxide of iron, alumina, carbonate of lime, and similar worthless materials.

No information could be obtained respecting the names of the vendors, or the price of the manure, which hardly deserves the name.

3. Mr. Edward Taylor, Whitton, Leintwardine, sent a sample of manure, which he purchased as genuine dissolved bones.

This manure, on examination, was found to contain no more than 10 per cent. of green bone at the most, and, consequently, was not genuine dissolved bones. The name of the dealer of these so-called dissolved bones could not be obtained.

4. Dr. Voelcker had previously reported on the composition of



a sample of fish and bone manure sent by Mr. Nathaniel Baskett, Braines Hall, Wetheringsett, Stonham, Suffolk, as follows:—

Moisture .. .. .	11·98
* Organic matter .. .. .	8·88
Phosphate of lime .. .. .	3·43
Sulphate and carbonate of lime .. .. .	51·06
Magnesia and alkaline salts .. .. .	2·70
Insoluble siliceous matter (sand) .. .. .	21·95
	100·00

* Containing nitrogen .. .. .	·31
Equal to ammonia .. .. .	·37

This manure was sold at 5*l.* a ton, but is scarcely worth 10*s.* a ton, delivered free of cost on the farm.

In answer to the inquiry made as to the vendors, Mr. Baskett wrote on July 6:—

“You applied to me for the name of the manufacturer of some fish and bone manure I sent you for analysis a short time since, and which you valued at the low sum of 10*s.* a ton. I beg to state that I had it from H. Marshall & Co., Wivenhoe, Essex; also from the same firm the guano sent to you at same time for analysis, and which you stated to be adulterated, and not worth more than 7*l.* 10*s.* a ton, and for which I paid 12*l.* 15*s.*”

“I am, yours faithfully,

“NATH. BASKETT.”

5. Mr. Baskett sent again, in July, two samples of manure, marked No. 1 and No. 4, which were both sold to him at 5*l.* a ton cash, delivered, by Messrs. H. Marshall and Co., Wivenhoe, Essex.

The two manures had the following composition:—

	No. 1.	No. 4.
Moisture .. .. .	7·51	9·68
*Organic matter .. .. .	16·25	11·85
Oxide of iron and alumina .. .. .	1·40	·89
Phosphate of lime .. .. .	2·46	5·72
Carbonate and sulphate of lime, &c. .. .. .	67·15	63·46
Insoluble siliceous matter .. .. .	5·23	8·40
	100·00	100·00
*Containing nitrogen .. .. .	·44	·49
Equal to ammonia .. .. .	·53	·59

No. 1 manure was scarcely better than the sample of fish and bone manure which Mr. Baskett sent before, and which was valued at 10s. a ton in comparison with Peruvian guano.

This manure, it will be seen, contains but little phosphate of lime, and yields only  $\frac{1}{2}$  per cent. of ammonia.

No 4 is very similar to No. 1, but somewhat richer in phosphate of lime, and worth about 7s. more per ton than No. 1. Both these manures consist principally of gypsum and carbonate of lime or chalk.

6. The next case is a sample of blood and bone manure, which was sent by Mr. T. H. Saunders, Watercombe Farm, near Dorchester, who states that it was manufactured by Messrs. Festine, Brothers, near Weymouth, and sold at 5*l.* a ton. On analysis its composition was found to be as follows:—

Moisture .. .. .	22·72
* Organic matter .. .. .	19·97
** Phosphoric acid .. .. .	1·82
Oxide of iron and alumina .. .. .	11·59
Lime, carbonate and sulphate of .. .. .	8·85
Alkalies, &c. .. .. .	5·73
Sand .. .. .	29·32
	100·00
* Containing nitrogen .. .. .	·88
Equal to ammonia .. .. .	1·07
** Equal to tribasic phosphate of lime .. .. .	3·97

This so-called blood and bone manure, it will be seen, contained only 4 per cent. of bone-phosphate, and only 1 per cent. of ammonia, and as much as  $22\frac{3}{4}$  per cent. of moisture, and 29 per cent. of sand. Dr. Voelcker reported it to be worth not more than 1*l.* 10s. a ton, but Mr. Saunders thinks 20s. a ton.

In the course of their inquiries the Chemical Committee frequently find that the vendor agrees to abide by the analysis of Professor Voelcker, and so, the purchaser being satisfied, there is no opportunity for further investigation. Two samples of cake, for instance, were submitted to Professor Voelcker; one, stamped pure, contained seeds of some 20 different weeds, and was made of very dirty seed. Another contained Castor-oil Beans; but the purchaser wrote that he was in correspondence with the vendor, and did not wish to have any further analysis.

The Committee have prepared the annexed forms of guarantee which dealers in manures and feeding-stuffs may give to purchasers. They will be supplied to applicants at a charge of 1*d.* each, or 1*s.* the set.

FORM TO BE SIGNED BY VENDORS OF ARTIFICIAL  
MANURES AND FEEDING STUFFS.

*As recommended by the Royal Agricultural Society of England.*

---

LINSEED-CAKE.

*Vendor's Name* \_\_\_\_\_

*Address* \_\_\_\_\_

*Quantity* \_\_\_\_\_

*Price per Ton* \_\_\_\_\_

*Terms* \_\_\_\_\_

\_\_\_\_\_  
*Date of Purchase* \_\_\_\_\_

I, the undersigned, hereby guarantee to deliver \_\_\_\_\_ tons of pure Linseed-cake as above, in good condition, that is to say:—Cake which is made from “clean” Linseed and nothing else, is free from mould, and is not otherwise spoiled for feeding purposes.

*Signature of Vendor* \_\_\_\_\_

FORM TO BE SIGNED BY VENDORS OF ARTIFICIAL  
MANURES AND FEEDING STUFFS.

*As recommended by the Royal Agricultural Society of England.*

RAPE-CAKE FOR FEEDING PURPOSES.

*Vendor's Name* \_\_\_\_\_

*Address* \_\_\_\_\_

*Quantity* \_\_\_\_\_

*Price per Ton* \_\_\_\_\_

*Terms* \_\_\_\_\_

*Date of Purchase* \_\_\_\_\_

I, the undersigned, hereby guarantee to deliver \_\_\_\_\_ tons of Rape-cake fit for feeding purposes, as above, in good condition, that is to say:—Cake which is made from Rape-seed, which is free from any injurious quantity of mustard or other prejudicial matters, is free from mould, and is not otherwise spoiled for feeding purposes.

*Signature of Vendor* \_\_\_\_\_

FORM TO BE SIGNED BY VENDORS OF ARTIFICIAL  
MANURES AND FEEDING STUFFS.

*As recommended by the Royal Agricultural Society of England.*

DECORTICATED COTTON-CAKE.

*Vendor's Name* \_\_\_\_\_

*Address* \_\_\_\_\_

*Quantity* \_\_\_\_\_

*Price per Ton* \_\_\_\_\_

*Terms* \_\_\_\_\_

*Date of Purchase* \_\_\_\_\_

I, the undersigned, hereby guarantee to deliver \_\_\_\_\_ tons of pure Decorticated Cotton-cake as above, in good condition, that is to say:—Cake which is made from clean Decorticated Cotton-seed, and nothing else, is free from mould, and is not otherwise spoiled for feeding purposes, and is equal to the sample furnished by me to the purchaser.

*Signature of Vendor* \_\_\_\_\_

N.B.—Purchasers are recommended not to buy this Cake except by sample.

FORM TO BE SIGNED BY VENDORS OF ARTIFICIAL  
MANURES AND FEEDING STUFFS.

*As recommended by the Royal Agricultural Society of England.*

UNDECORTICATED COTTON-CAKE.

*Vendor's Name* \_\_\_\_\_

*Address* \_\_\_\_\_

*Quantity* \_\_\_\_\_

*Price per Ton* \_\_\_\_\_

*Terms* \_\_\_\_\_

*Date of Purchase* \_\_\_\_\_

I, the undersigned, hereby guarantee to deliver \_\_\_\_\_ tons  
of pure Undecorticated Cotton-cake as above, in good condition  
that is to say:—Cake which is made from clean Undecorticated  
Cotton-seed, and nothing else, is free from mould, is not other-  
wise spoiled for feeding purposes, and is equal to the sample  
furnished by me to the purchaser.

*Signature of Vendor* \_\_\_\_\_

N.B.—Purchasers are recommended not to buy this Cake except  
by sample.

FORM TO BE SIGNED BY VENDORS OF ARTIFICIAL  
MANURES AND FEEDING STUFFS.

*As recommended by the Royal Agricultural Society of England.*

\_\_\_\_\_

RICE-MEAL.

*Vendor's Name* \_\_\_\_\_

*Address* \_\_\_\_\_

*Quantity* \_\_\_\_\_

*Price per Ton* \_\_\_\_\_

*Terms* \_\_\_\_\_

\_\_\_\_\_

*Date of Purchase* \_\_\_\_\_

I, the undersigned, hereby guarantee to deliver \_\_\_\_\_ tons  
of pure Rice-Meal, as above, in good condition, that is to say :—  
Meal that is free from all matters not found in rice, and that  
is equal to the sample furnished by me to the purchaser.

*Signature of Vendor* \_\_\_\_\_

N.B.—Purchasers are recommended not to buy this Meal except  
by sample.

FORM TO BE SIGNED BY VENDORS OF ARTIFICIAL  
MANURES AND FEEDING STUFFS.

*As recommended by the Royal Agricultural Society of England.*

BONES OR BONE-DUST.

Bones and Bone-dust are usually sold either as raw or green bone, or as boiled bones. The latter is made from bones the gelatine of which has been extracted to a great extent by high-pressure steam, and is cheaper than raw bone-dust.

*Vendor's Name* \_\_\_\_\_

*Address* \_\_\_\_\_

*Quantity* { *Raw Bones,  $\frac{1}{2}$  inch* \_\_\_\_\_  
*Raw Bones,  $\frac{1}{4}$  inch* \_\_\_\_\_  
*Raw Bone-dust* \_\_\_\_\_  
*Boiled Bones* \_\_\_\_\_

*Price per Ton* \_\_\_\_\_

*Terms* \_\_\_\_\_

*Date of Purchase* \_\_\_\_\_

RAW OR GREEN BONES OR BONE-DUST.

I, the undersigned, hereby guarantee to deliver \_\_\_\_\_ tons of pure raw Bones, being  $\frac{1}{2}$  inch, or  $\frac{1}{4}$  inch, or fine Bone-dust, as above, containing not less than 45 per cent. of tribasic phosphate of lime, and yielding not less than 4 per cent. of ammonia.

*Signature of Vendor* \_\_\_\_\_

BOILED BONES.

I, the undersigned, hereby guarantee to deliver \_\_\_\_\_ tons of pure boiled Bones, as above, containing not less than 48 per cent. of tribasic phosphate of lime, and yielding not less than  $1\frac{3}{4}$  per cent. of ammonia.

*Signature of Vendor* \_\_\_\_\_



## FORM TO BE SIGNED BY VENDORS OF ARTIFICIAL MANURES AND FEEDING STUFFS.

*As recommended by the Royal Agricultural Society of England.*

### DISSOLVED BONES.

Dissolved bones are made of various qualities, and sold at various prices per ton, and for these reasons the quality should be guaranteed.

Vendor's Name \_\_\_\_\_

Address \_\_\_\_\_

Quantity \_\_\_\_\_

Price per Ton \_\_\_\_\_

Terms \_\_\_\_\_

Date of Purchase \_\_\_\_\_

I, the undersigned, hereby guarantee to deliver, in a sufficiently dry and powdery condition to admit of ready distribution by the drill or for hand-sowing, \_\_\_\_\_ tons of dissolved bone at \_\_\_\_\_ per ton, which shall contain—

1. \_\_\_\_\_ per cent. of *soluble* phosphate of lime.
2. \_\_\_\_\_ per cent. of *insoluble* phosphate of lime, present entirely as boiled or raw bone, and not as bone-ash, coprolites, or other mineral phosphates.
3. \_\_\_\_\_ per cent. of nitrogen equal to \_\_\_\_\_ per cent. of ammonia.

In case of deficiency I agree to allow for each unit per cent. which the dissolved bones are found on analysis to contain less than the guaranteed percentage of soluble phosphate of lime in a fairly drawn sample, taken within three days after the delivery of the bulk:—

1. Of soluble phosphate \_\_\_\_\_ per ton,
2. Of insoluble phosphate \_\_\_\_\_ per ton,
3. Of ammonia \_\_\_\_\_ per ton,

Signature of Vendor \_\_\_\_\_

N.B. The sample for analysis should be taken by emptying several bags, mixing the contents together, and filling two mustard tins full in the presence of a witness; both to be sealed, one to be forwarded to \_\_\_\_\_ for the determination of its constituents, and the second to be kept for reference.

FORM TO BE SIGNED BY VENDORS OF ARTIFICIAL  
MANURES AND FEEDING STUFFS.

*As recommended by the Royal Agricultural Society of England.*

MINERAL SUPERPHOSPHATES.

Purchasers are recommended to buy Mineral Superphosphates on the basis of a guaranteed percentage of *soluble* phosphate of lime, at so much per unit per cent., and to attach no value to insoluble phosphates.

*Vendor's Name* \_\_\_\_\_

*Address* \_\_\_\_\_

*Price per Ton* \_\_\_\_\_

*Terms* \_\_\_\_\_

*Date of Purchase* \_\_\_\_\_

I, the undersigned, hereby guarantee to deliver, in a sufficiently dry and powdery condition to admit of ready distribution by the drill, or for hand-sowing, \_\_\_\_\_ tons of Superphosphate of Lime, as above, which shall contain \_\_\_\_\_ per cent. of soluble phosphate of lime; a deduction of \_\_\_\_\_ being allowed for every unit per cent. which the superphosphate is found on analysis to contain less than the guaranteed percentage of soluble phosphate of lime in a fairly drawn sample, taken within three days after the delivery of the bulk.

*Signature of Vendor* \_\_\_\_\_

N.B.—The sample for analysis should be taken by emptying several bags, mixing the contents together, and filling two mustard tins full in the presence of a witness; both to be sealed, one to be forwarded to \_\_\_\_\_ for the determination of soluble phosphate, and the second to be kept for reference.

FORM TO BE SIGNED BY VENDORS OF ARTIFICIAL  
MANURES AND FEEDING STUFFS.

*As recommended by the Royal Agricultural Society of England.*

COMPOUND ARTIFICIAL MANURES.

Vendor's Name \_\_\_\_\_

Address \_\_\_\_\_

Quantity \_\_\_\_\_

Price per Ton \_\_\_\_\_

Terms \_\_\_\_\_

Date of Purchase \_\_\_\_\_

I, the undersigned, hereby guarantee to deliver, in a sufficiently dry and powdery condition to admit of distribution by the drill, or for hand-sowing, \_\_\_\_\_ tons of as above, to contain \_\_\_\_\_ per cent. of soluble phosphates, \_\_\_\_\_ per cent. of insoluble phosphates, \_\_\_\_\_ per cent. of nitrogen.

In case of deficiency, I agree to allow for each unit per cent. which the manure is found, on analysis, to contain less than the guaranteed percentage of soluble phosphate of lime in a fairly drawn sample, taken within three days after the delivery of the bulk :—

1. Of soluble phosphates \_\_\_\_\_ per ton,
2. Of insoluble phosphates \_\_\_\_\_ per ton,
3. Of ammonia \_\_\_\_\_ per ton.

Signature of Vendor \_\_\_\_\_

N.B.—The sample for analysis should be taken by emptying several bags, mixing the contents together, and filling two mustard tins full in the presence of a witness; both to be sealed, one to be forwarded to \_\_\_\_\_ for the determination of its constituents, and the second to be kept for reference.

FORM TO BE SIGNED BY VENDORS OF ARTIFICIAL  
MANURES AND FEEDING STUFFS.

*As recommended by the Royal Agricultural Society of England.*

## NITRATE OF SODA.

*Vendor's Name* \_\_\_\_\_

*Address* \_\_\_\_\_

*Quantity* \_\_\_\_\_

*Price per Ton* \_\_\_\_\_

*Terms* \_\_\_\_\_

*Date of Purchase* \_\_\_\_\_

I, the undersigned, hereby guarantee to deliver \_\_\_\_\_ tons  
of nitrate of soda, as above, to contain from 94 to 95 per cent. of  
pure nitrate.

*Signature of Vendor* \_\_\_\_\_

FORM TO BE SIGNED BY VENDORS OF ARTIFICIAL  
MANURES AND FEEDING STUFFS.

*As recommended by the Royal Agricultural Society of England.*

---

SULPHATE OF AMMONIA.

*Vendor's Name* \_\_\_\_\_

*Address* \_\_\_\_\_

*Quantity* \_\_\_\_\_

*Price per Ton* \_\_\_\_\_

*Terms* \_\_\_\_\_

\_\_\_\_\_

*Date of Purchase* \_\_\_\_\_

I, the undersigned, hereby guarantee to deliver sulphate of ammonia, as above, to contain not less than 23 per cent. of ammonia.

*Signature of Vendor* \_\_\_\_\_

FORM TO BE SIGNED BY VENDORS OF ARTIFICIAL  
MANURES AND FEEDING STUFFS.

*As recommended by the Royal Agricultural Society of England.*

SHODDY.

The quality of shoddy or wool-refuse manure varies greatly, and its value mainly depends upon the amount of nitrogen which a sample contains.

*Vendor's Name* \_\_\_\_\_

*Address* \_\_\_\_\_

*Quantity* \_\_\_\_\_

*Price per Ton* \_\_\_\_\_

*Terms* \_\_\_\_\_

*Date of Purchase* \_\_\_\_\_

I, the undersigned, hereby guarantee to deliver \_\_\_\_\_ of Shoddy, as above, in a dry condition, containing \_\_\_\_\_ per cent. of nitrogen (equal to \_\_\_\_\_ per cent. of ammonia) at \_\_\_\_\_ per unit per cent. of ammonia: a deduction of \_\_\_\_\_ being allowed for every unit per cent. which the Shoddy is found on analysis to contain less than the guaranteed percentage of ammonia in a fairly drawn sample, taken within three days after the delivery of the bulk.

*Signature of Vendor* \_\_\_\_\_

FORM TO BE SIGNED BY VENDORS OF ARTIFICIAL  
MANURES AND FEEDING STUFFS.

*As recommended by the Royal Agricultural Society of England.*

PERUVIAN GUANO.

*Vendor's Name* \_\_\_\_\_

*Address* \_\_\_\_\_

*Quantity* \_\_\_\_\_

*Price per Ton* \_\_\_\_\_

*Terms* \_\_\_\_\_

*Date of Purchase* \_\_\_\_\_

I, the undersigned, hereby guarantee to deliver \_\_\_\_\_ tons of  
genuine Peruvian Guano, as above, the said Guano to contain  
\_\_\_\_\_ per cent. of ammonia, and to be in a dry and friable  
condition.

*Signature of Vendor* \_\_\_\_\_

FORM TO BE SIGNED BY VENDORS OF ARTIFICIAL  
MANURES AND FEEDING STUFFS.

*As recommended by the Royal Agricultural Society of England.*

REFUSE MANURING MATTER.

*Vendor's Name* \_\_\_\_\_

*Address* \_\_\_\_\_

*Quantity* \_\_\_\_\_

*Price per Ton* \_\_\_\_\_

*Terms* \_\_\_\_\_

*Date of Purchase* \_\_\_\_\_

I, the undersigned, hereby guarantee to deliver \_\_\_\_\_ tons  
of \_\_\_\_\_ Manure, as above, the said Manure to  
contain \_\_\_\_\_ per cent. of phosphate of lime ; \_\_\_\_\_ per cent.  
of nitrogen, equal to \_\_\_\_\_ per cent. of ammonia ; and not  
more than \_\_\_\_\_ per cent. of moisture.

*Signature of Vendor* \_\_\_\_\_



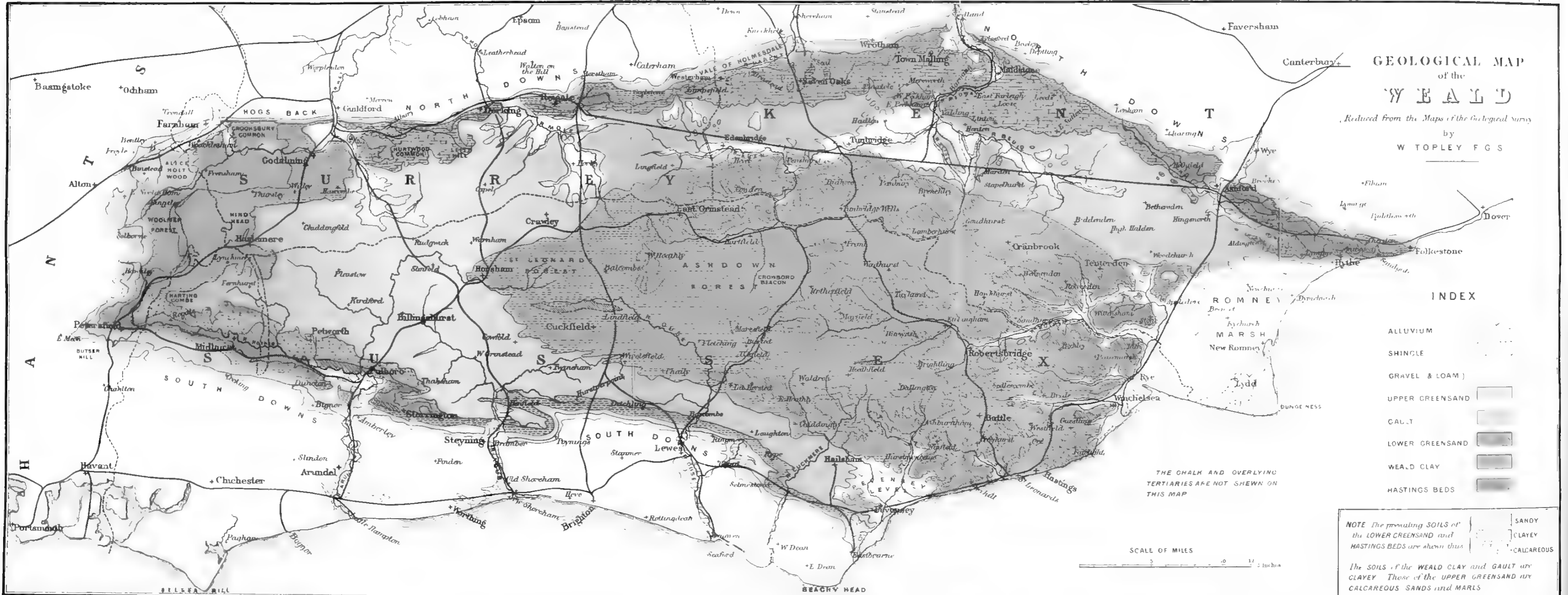



JOURNAL  
OF THE  
ROYAL AGRICULTURAL SOCIETY  
OF ENGLAND.

---

XII.—*On the Agricultural Geology of the Weald.* By WILLIAM TOPLEY, F.G.S., of the Geological Survey of England and Wales. [With a Map.]

INTRODUCTION.

THE following essay is offered as an explanation of the Geology of the Wealden district, so far as it relates to agriculture. Purely geological details are, for the most part, omitted, and no notice is taken of many interesting theoretical questions, for the discussion of which the Weald has long been a favourite battle-ground. The map has been reduced from the sheets of the Geological Survey, and all details which it is possible to give on so small a scale have been inserted. Some of the subordinate divisions of the central area (Hastings Beds), which have been mapped by the Survey, are necessarily in great part omitted; but the district has been grouped according to the prevailing soil, further refinement being impracticable. The general character of the soil overlying the Lower Greensand is shown independently of the geological colouring.

Over a great part of England an ordinary geological map is of very little use to the farmer, for there are often widespread deposits of "drift" which completely cover up the rocks and determine the soil of the district. This soil may differ widely from that of the rock itself; and a map or an essay treating only of the geology proper, and neglecting these drift-soils, might give an altogether false idea of the agricultural features of the district.

In writing on the Agricultural Geology of the Weald we are more fortunate; for not only do the great physical features of the country and their prevailing soils strikingly agree with the geological divisions, as shown on any ordinary map, but the central district, in which the alternations of light and stiff soil are frequent and sudden, has been mapped in great detail by the Geological Survey. It is a district but little covered by superficial deposits;

but these also are shown in all late impressions of the Survey maps, which may therefore be considered as Agricultural maps.

The district of the Weald, in its original meaning—that of Wild, Wold, or Wood—comprised only the area below and within the Lower Greensand hills; and where mention is made of the Wealds of Kent, Surrey, or Sussex, this district only is generally referred to. But of late years the term has acquired a more extended meaning, and is now often taken to include all the country within and below the Chalk hills. In this enlarged meaning the term is here used. It is very convenient to have a word embracing the whole of so well-defined a district; and when, hereafter, the word is used in its ancient and more restricted sense, the fact will be sufficiently obvious.

The Weald may be described, in general terms, as consisting of a central undulating region of great extent, within which nearly every variety of soil occurs. The beds underlying this tract are the lowest of the series (Hastings Beds); they “dip” or incline outwards in all directions, and pass under the next division or the Weald Clay, which forms a flat country passing all round the Hastings Beds, excepting where it, like all the other divisions, is cut off by the coast line. This clay passes under the Lower Greensand, which is always associated with rising ground, and generally with a steep slope or “escarpment.” The soils on this formation are generally light; it passes under the Gault, which forms a narrow zone of clay underlying the lighter land of the Upper Greensand. The highest bed of the Cretaceous series is the Chalk, which overlooks the inner country in a fine escarpment, passing completely round the district, broken only by narrow valleys through which the rivers escape.

The crest of the Chalk escarpment is, in Kent and Surrey, a tolerably uniform flat, varying in height from 500 to nearly 900 feet. In Sussex and Hants it is more varied in outline: the highest point is Butser Hill, south of Petersfield, 882 feet. The Lower Greensand country is generally of much less elevation than the Chalk, but in the western part of Surrey it attains the height of 967 feet at Leith Hill. The highest point of the central country is Crowborough Beacon, in Ashdown Forest, 803 feet.

The following table exhibits the succession of the beds, in descending order, with their thicknesses, &c.\*—

---

\* The thicknesses here given are from the horizontal sections of the Geological Survey and the sources named below. The names of the subdivisions of the Lower Greensand (except the lowest), and of the Hastings Beds (also except the lowest), were given by Mr. F. Drew, of the Geological Survey, and have been adopted on the Survey Maps. Those of the Lower Greensand are taken from places on the Kentish Coast where they are well seen. Those of the Hastings Beds are from localities within the Weald, around which the respective divisions are largely developed.—(See ‘Memoirs Geol. Survey,’ sheet 4, and ‘Quart. Journ. Geol. Soc.,’ vol. xvii., p. 271.)

	Thickness in Feet.	Character.	Agricultural Products.	Building and Roadstone, &c.
Chalk .. .. .	600	Calcareous .. .. .	Chalk .. .. .	Flints.
Upper Greensand .. .. .	400	Calcareous and Marly.	Lime and Marl.	
Gault .. .. .	0-90	{ Calcareous, Marly, and Sandy .. .. . }	Phosphates and Silica Rock .. .. .	Firestone.
Lower Greensand .. .. .	50-200?	Clay .. .. .	Phosphates, Marl (rarely).	
Wald Clay .. .. .	80-180	Sand .. .. .	.. .. .	{ Iron-Sandstone and Calc-Stone (at Folkestone).
Hastings Beds .. .. .	0-80	Sandy Clay .. .. .	.. .. .	Fuller's Earth.
Wald Clay .. .. .	60-300	Limestone and Sand Clay.	Lime .. .. .	Limestone.
Hastings Beds .. .. .	20-60	{ Clay (with thin beds of Sand and Lime- stone) .. .. . }	Clay ("Marl"), Lime	{ Limestone and Iron- stone.
Wald Clay .. .. .	500-900	Sand (with Clay) .. .. .	.. .. .	Sandstone.
Hastings Beds .. .. .	150-300	Clay .. .. .	Clay ("Marl") .. .. .	Ironstone.
Hastings Beds .. .. .	100-180	Sand .. .. .	.. .. .	Sandstone.
Hastings Beds .. .. .	160-350	{ Clay, Limestone, and Sandstone .. .. . }	Lime .. .. .	Limestone.

The chief characteristic of the climate of the district is an excessive rainfall. This is partly attributable to the height of the country, and partly to its proximity to the southern coast, which has a rainfall varying from 40 inches in Cornwall and Devon, decreasing eastwards to 30 inches in Hants, and 29 inches at Hastings. Inland, however, it increases; for at Uckfield it is 33 inches, and at Selborne 34 inches. Uckfield is on the southern slope of the central region, at about 130 feet above the sea, and distant about seven miles from the high South Downs, there being no high land intervening: it is therefore well exposed to the rainy winds. Selborne, though sheltered by the Chalk hills, lies higher—whence, no doubt, its greater rainfall.

The rainfall at Chichester is 29 inches, the same as at Hastings. At Cobham, in the north of Surrey, 24 inches; and at Canterbury 27 inches.

The great corn district of England, extending through the vale of York southwards, by the Eastern-Midland counties towards the valley of the Severn, has a fall varying from 20 to 24 inches. The Severn plain, extending from Gloucester northwards by Shrewsbury, is mostly under 30 inches.\* It will thus be seen that, as far as rainfall is concerned, the Weald is less favourably situated than the typical wheat districts. Probably if more woodland were cleared the rainfall would be less.

#### CHALK.

Of this formation but a small area belongs to the district under consideration,—only the face of the escarpment. This is everywhere in grass, except a few places of very limited extent, where wood occurs. Box often grows on the face of the escarpment, whence the names Box Hill and Boxley; there is also a good deal of Juniper and Yew; but Beech is the tree which especially characterises the chalk. Arable land extends upwards from the Upper Greensand terrace as far as the slope of the ground will permit; but the middle and upper parts of the escarpment are too steep for the plough, sometimes as much as 30°, and are left as sheepwalks.

The most productive soil is formed by the lowest or marly chalk, and this is always under the plough. The least productive is that of the “chalk-without-flints,” and this, on the escarpment, is necessarily in grass, though beyond the escarp-

\* These numbers, the mean of the years 1860-65, are taken from Mr. Symons' “Rain: How it is Measured,” 1867, p. 52. Mr. Symons, as the result of numerous calculations, considers that the mean of these six years agrees very closely with the mean of the forty years 1810-49.

ment, where exposed on the side of valleys, it is generally arable land.

Large quantities of chalk are dug from the lower beds for lime-burning. All round the Weald, at intervals, there are huge excavations in the hill-sides, from whence chalk for this purpose is or has been taken. Chalk for "chalking" is generally got from the upper beds with flints.

The deposits upon the chalk are not shown on the map, and do not come within the Wealden area; to which the escarpment is a well-defined boundary. They may, however, be briefly described. The most abundant is a stiff, red or black clay, containing large quantities of flints, often entire, or, if broken, never at all rounded or waterworn. This is called by geologists, "clay-with-flints;" it is probably a result of the decomposition of the chalk, and not a "deposit." It is an exceedingly stiff, adhesive clay, very difficult to work. The thickness is very variable, and it generally rests upon an uneven surface of the chalk, having been let down into "pipes" or "pot-holes." This occurs all along the North Downs from the coast to the neighbourhood of Guildford. It occurs again in Hants, but in a less continuous manner than in Kent. Only small areas of the Sussex chalk are thus covered.

There are patches of sand, making a light soil, on the Downs near Folkestone, and as far west as the River Stour, beyond which the sand chiefly occurs in "pipes," and scarcely influences the soil. Still further west, near Guildford, there are deposits of flint-gravel, which make a light and barren soil.

Water is scarce on the chalk. The wells are deep, being often sunk 200 or 300 feet before reaching the water-level. Rain-water is therefore carefully stored, and puddled ponds are made at various points on the farms. There are frequently strong springs at the base of the escarpment.

The valleys which begin near the top of the escarpment and flow outwards, are nearly always dry for the first few miles of their course, and often for much longer distances. After very wet seasons, when the water-level rises in the chalk, streams run for a time in some of the deepest of these valleys; such inconstant streams are called "Nailbourns" in Kent, "Winterbourns" in Dorset and Hampshire, and "Gipsies" in Yorkshire. At the bottom of these "dry valleys" there is a bed of flints, often of considerable thickness, intermixed with a chalky loam. This forms an excellent soil, although, to one walking over the field, it appears little but flints. The flints are rarely picked off the field, this being found to impoverish the land; they probably not only afford shade to the young plants, but serve to increase

the bulk of the soil, so that roots can penetrate to a greater depth, in good soil, than without them.\*

Not much of the Kentish Chalk is unenclosed, but very large areas of the Sussex Chalk are in open "Downs." This difference is owing to the greater quantity of superficial covering in Kent than in Sussex. Mushrooms grow in great quantities on the Sussex Downs, and it is on record that the produce of a field of 11 acres sold one summer for 25*l.*†

#### UPPER GREENSAND.

On the coast at Folkestone this formation is seen to consist of a greenish sand, calcareous or clayey as it approaches the Chalk above or the Gault below. Its thickness is about 20 feet, but inland it rapidly thins away in a mile or two, and is represented only by some green grains at the base of the chalk. There are no hard beds of firestone at Folkestone.

In Surrey the Upper Greensand becomes important, and forms a well-marked terrace at the foot of the Chalk escarpment; and from thence, all round the Weald, to the coast at Eastbourne, it has the same general characters.

In Surrey it consists of three divisions:—At the top, just below the lowest marly chalk, is a greenish marly sand with phosphatic nodules; below this comes a siliceous rock of various degrees of hardness and thickness; the harder beds are known as "firestone." It is this division which yields a high percentage of soluble silica. Sometimes there are hard beds of blue limestone, which are quarried for building stone. Below this is a greyish marl or clay, resting upon and passing into the blue clay of the Gault, with which, perhaps, it might be classed, for there is no strong natural line between Upper Greensand and Gault.

The divisions of the Upper Greensand, as they exist near Farnham, have been already described in this Journal by Messrs. Way and Paine.‡ The silica which occurs in a soluble

---

\* "So thick is the flint-drift, spread like a coverlet on a bed of chalk, in some of the dry hollows, that cultivation would seem as little profitable there as on the shingle of a sea-beach. But you are re-assured when told of the costly experience of a new-comer, who, having picked off the flints and carted them away, and thereby lost his crops, acknowledged his error by restoring them, as shelter against March winds, protection against summer suns, and warmth against winter frosts."—*Dickenson's Farming of Hampshire* ('*Journ. Roy. Agr. Soc.*,' vol. xxii., p. 253).

† M. A. Lower. "The South Downs." '*Contributions to Literature*,' p. 154.

‡ 'On the Silica Strata of the Lower Chalk,' vol. xiv., p. 225. This, and two other papers in the Society's Journal by the same authors, must be read by all who would study the Agricultural Geology of the Upper Cretaceous Beds; particularly those of the neighbourhood of Farnham. (See 'On the Phosphoric Strata



state\* varies from 2 to 75 per cent. "Those beds which contain a high percentage of silica are, when dry, remarkably light, of a fawn or reddish yellow colour, and very soft, except in some instances where the silica is associated with carbonate of lime. . ."

The persistency of this soluble silica over large areas upon the same geological horizon is very remarkable. Messrs. Way and Paine examined the Upper Greensand of the Isle of Wight, and there found soluble silica, though to a less extent than at Farnham. They quote an analysis, by M. Sauvage, of the Upper Greensand at Ardennes, where the bed contains 56 per cent. An analysis recently published of the same bed, in the Pays de Bray, gives 50 per cent. of soluble silica.†

The outcropping of this stratum is everywhere characterised by great fertility, and is especially remarkable for the excellence of its wheat and hops. Large quantities of the siliceous rock have been dug as manure.

The terrace formed by the Upper Greensand is particularly well marked in Hants and West Sussex.

Besides the papers by Messrs. Way and Paine, this district has been described in the 'Report on Surrey,' by Mr. H. Evershed,‡ and in that on Hants by the Rev. T. Wilkinson.§ It is therefore unnecessary to go again over ground which is already familiar to readers of this Journal.

### THE GAULT.

This division exhibits less variety in its character than any other, excepting perhaps the Chalk. It consists everywhere of a blue or black clay, which weathers brown, and is occasionally dug for tiles. Its soil, known as "black land," is always stiff and hard to plough, but when drained it makes excellent land; perhaps as good as any in the South of England, except the Upper Greensand. At present a large proportion of it is in pasture. The middle portion is most productive; it contains the greatest percentage of carbonate of lime, and is, in fact, a marl.

At the base, and resting immediately on the Lower Greensand, is a phosphatic layer, which is remarkably persistent throughout

---

of the Chalk Formation,' vol. ix., p. 56; and 'The Chemical and Agricultural Characters of the Chalk Formation,' vol. xii., p. 544.) These three papers, taken together, are certainly the ablest contribution to Agricultural and Chemical Geology that have appeared in England.

\* That is, soluble only very slightly in water, but largely so in alkaline solutions.

† Lapparent. 'Bull. Soc. Géol. de France,' ser. 2, tom. xxiv., p. 230.

‡ 'Journal of the Royal Agricultural Society,' vol. xiv., p. 406.

§ *Ibid.*, vol. xxii., p. 254. An excellent description of the Chalk area of Hants (applying also to that of West Sussex) is given in this report.

the district. The phosphate of lime occurs as nodules in a loose ferruginous matrix. Fossils are abundant; they are generally in fragments, and are always phosphatic. This bed is of small thickness, rarely exceeding a foot; but occasionally other thin layers occur, and sometimes there are loose nodules in the sand just below. When exposed to the weather, this layer hardens and holds up water. The lower part of the Gault when undrained, and with the crust unbroken, is said to be often wet and poor from this cause.

The Middle Gault, from the quantity of carbonate of lime it contains, is best adapted for manure. It is sometimes dug for this purpose, chiefly so in West Surrey and Hants, where it is applied to light land with great success. This stratum, and the top layer of the Upper Greensand, are the only beds occurring in the Weald to which the term "marl" can fairly be applied. The "chalk-marl" is a calcareous rock containing some clay, and the so-called "marls" of the Wealden are simply shales, with very little, if any, lime.

The Gault is but little covered with drift, and chiefly so where crossed by the rivers, just before they pierce the Chalk escarpment. The largest area thus covered is on the River Stour, to the north of Ashford. The gravels of the Wey, near Farnham; of the Darent, north of Sevenoaks; and of the Arun, at Hardham, also overlie Gault clay. On the north of Maidstone, besides the ordinary river-gravel of the Medway, there is a covering, some 12 feet or more thick in places, of chalky wash, containing some flints. It forms a marly soil less stiff than the Gault itself. Perhaps there is occasionally some wash resembling this at the foot of the Chalk escarpment in other places, but it certainly is not common, and cannot anywhere be of great extent.

In Surrey, from about Wotton, westwards, the dip of the beds is high and the Gault thin, so that little is seen of it. On the borders of Hants, at the north-west corner of the Weald, it spreads over a considerable area at Alice Holt Wood, the soil of which is a wet yellow clay containing some flints. Here is the greatest elevation attained by the Gault in the Wealden area.

#### LOWER GREENSAND.

This formation offers in every respect a marked contrast to that last described. It always rises up from beneath the Gault valley and forms hilly ground, often attaining to a great height. It varies very much in composition, and, consequently, in agricultural character. Generally it consists of four subdivisions, as is the case in Kent, East Surrey, and West Sussex. In West

Surrey, although the formation is largely developed, its divisions are less sharply marked; and in East Sussex the whole formation is thin and more uniform in character.

The lowest division, or *Atherfield Clay*, may be briefly dismissed. Lithologically it should be classed with the Weald Clay on which it immediately rests, but its fossil contents have caused it to be separated therefrom by geologists. It is a stiff clay, generally brown, and sometimes containing limestone beds. Its thickness is variable, and cannot always be determined, but it never occupies much ground. It crops out everywhere, towards the lower part of the Lower Greensand escarpment excepting in East Sussex, where, as already mentioned, the whole formation is thin. It is sometimes reached in valleys within the Lower Greensand area, and then always throws out strong springs—as at Loose and Leeds Abbey in Kent—and in many valleys of the Leith Hill district.

The land described in the following extract from Mr. G. Buckland's Report is that occupied by Atherfield Clay. "There is a very narrow belt of land running along the escarpment of the rag-stone, provincially called *Coomb* (the débris of the Greensand, connecting it with the Weald Clay below), which, although of a very heavy and adhesive texture, is astonishingly productive in hops, fruit, and grain. This land is sometimes so wet and stiff as to set the operations of ploughing at defiance; draining it, however, will materially alter its character, and this method of improvement is being extensively practised. The natural fertility of this soil is owing to its happy mineral composition and the large amount of calcareous matter it contains."\*

In the map accompanying this paper the Atherfield Clay is classed with the Weald Clay; its soil differing totally from the Lower Greensand divisions above it.

It has just been remarked, that the Lower Greensand varies much in its character; this is especially true of the second and third subdivisions, or rather of the third (*Hythe Beds*); the *Sandgate Beds*, though somewhat variable, give generally a wet soil compared with the divisions adjoining; but for several miles they do not occur, or are so thin as to make but little show at the surface. The top and bottom divisions of the Lower Greensand exhibit the least variation in character, but the bottom bed (*Atherfield Clay*) is perhaps not always present.

The top division (*Folkestone Beds*) is tolerably constant in character, and always gives a very light soil. It consists of

---

\* "Farming of Kent." Journal of the Royal Agricultural Society, vol. vi., p. 279. 1846.

loose sand, generally light in colour, but sometimes red, as at *Redhill*. At *Folkestone*, and for a few miles westwards, it contains beds of a hard calcareous sandstone, and much of the sand itself is somewhat calcareous. To this cause is probably owing the superior fertility of the land overlying this division between *Ashford* and *Folkestone*. To the west of *Ashford* there are, at intervals, commons and heaths on this bed, and here the calcareous sand and sandstone are absent. This light land might be vastly improved by marling from the *Middle Gault*, in which there is much carbonate of lime.

The outcrop in Kent varies in breadth from one-third of a mile to one mile; rarely exceeding the latter, excepting on the border of the *Medway*, south of *Snodland*, where it is two miles broad. It again makes a wider spread than usual on the south of *Merstham*, from whence to its great development in *West Surrey* its outcrop is narrowed. A large "outlier" occurs on the south-east of *Guildford*, forming the high land of *Blackheath*, and *Farley Heath*. The largest and least fertile area formed by these sands is that on the south and south-east of *Farnham*, where above 30 square miles of them were formerly chiefly in common and heath, and a large part of which is still uninclosed. The heath land of the *Folkestone Beds* is here not plainly marked off from the almost equally sterile land of the *Hythe Beds*. The total area occupied by *Lower Greensand* west of *Guildford*, south of the *Hog's Back* and including *Woolmer Forest*, is over 130 square miles.

The most noticeable product of this upper division is a very hard, dark red, or brown ferruginous sandstone, occurring chiefly in irregular veins and beds throughout the sand. It is much used for road stone and rough paving.

The *Folkestone Beds* retain pretty much the same character in *Hants* and *Sussex*, and are marked throughout their whole extent by heaths and commons.

The *Sandgate Beds* form generally a depression between the harder divisions above and below. As a whole they are clayey, and generally form wet springy ground which requires drainage. But they are not stiff in the sense that the *Gault* or *Weald Clay* are so. Compared with these the ground of the *Sandgate Beds* would be, generally, only a stiffish loam. There are in places small areas of stiffer soil; but there are, on the other hand, larger areas which are at most only loamy sands.

*Fuller's Earth* has been got from these beds in the neighbourhood of *Nutfield* for a great length of time. It is here most largely developed, but also occurs, and was formerly worked, near *Maidstone*. Traces of this division are seen more or less throughout the *Greensand* range of Kent, but it is only

drawn on the map for a few miles west of Ashford, beyond which its outcrop will be the boundary line between the Folkestone and Hythe Beds.

*Hythe Beds.*—This division is in every respect the most important of the Lower Greensand series. It occupies the largest area, forms the most fertile soil, and yields more valuable economic products than any other.

Throughout Kent it consists of beds of Limestone (Kentish Rag), and a calcareous sand or soft sandstone, known as “has-sock.” The former is very largely dug as a building stone, and also for roads. The famous district of Mid-Kent owes the chief part of its fertility to soils overlying this division, which occupies a large area on the south of Maidstone, but narrows to the east and west. The soil formed by its decomposition is stony, containing fragments of rag, and, occasionally, pieces of chert—a hard siliceous rock, which occurs in thin beds, but chiefly so to the west of Maidstone. The soil is, of course, naturally drained, and the Kentish Rag country would be as destitute of surface water as the Chalk, if it were not that many of the valleys reach down to the Atherfield Clay, which always throws out copious springs.

The hop gardens of the Maidstone district are almost all on the ragstone soil, with occasionally a thin covering of gravel and loam. The Hythe Beds, forming the highest land of the Greensand area, are not usually much covered by gravels, and to this rule Maidstone is no exception. There are, however, in that district large deposits of brick-earth, which are not spread out over the surface in the same manner as the brick-earth overlying the Weald Clay, but occur in long “pipes” of great dimensions. Some are known to be 50 feet deep, and a quarter of a mile long; the widest is 50 yards across. These enormous gaps in the ragstone are filled with loam, which sometimes contains a little gravel, but almost the whole contents are available for brick-making. Probably the loam from such “pipes” getting spread over the surface of the adjoining rag, adds to its fertility; otherwise it is difficult to account for the great superiority of the soil in the Maidstone district. Farther east, between the Medway and the coast, the mineral character of the rocks is much the same as at Maidstone; but there the brick-earth pipes are absent, and the soil, though still of good quality, is less productive than that on the banks of the Medway. It is not maintained that the brick-earth alone makes this highly productive soil, but that its admixture with the ragstone soil probably has a fertilising effect. Great deposits of brick-earth overlie the Weald Clay around Hadlow, but the soil

is of less value than that of the ragstone hills, and the hops grown are, generally, of a coarser quality.

The most noticeable products of the ragstone districts are hops and fruit; very large quantities of the former are grown between Maidstone and Yalding, especially in the parish of East Farleigh. There was, some years back, a largish area of ragstone country unenclosed (Cox Heath), near the crest of the escarpment, south of Maidstone. It is somewhat remarkable that so much land on a ragstone soil should have been allowed to lie waste so long. I am not aware that any brick-earth occurs near there.

On the west of the Medway there are some very large woods on the higher ground of the Hythe Beds (East Malling, Mereworth, and Great Comp Woods). Over a part of this land a sticky sort of "gravel" occurs, forming a wetter soil than the simple ragstone. It is composed of angular pieces of chert mixed with a reddish loamy clay, and seems to represent the "clay-with-flints" of the Chalk country. Probably both are formed in the same manner: by the gradual dissolving away of the limestone by rain-water, leaving the clayey particles and the undissolved chert. This stuff, locally misnamed "gravel," is sometimes dug for garden paths, &c.

The Lower Greensand country is of no great height on the east of the Medway, although the escarpment is a striking feature rising from the low and flat Weald Clay plain. On the west of the Medway it rises to a height of 550 feet in Great Comp Wood; there is then a fall into the valley east of Plaxtole, beyond which the escarpment has a general westerly rise; some half-a-dozen points on the west of Sevenoaks attaining a height of 700 feet. The summit (810 feet) is on the south of Brasted, half a mile north of Bardolvs Farm; this is one of the very few places in which the Greensand escarpment attains as great a height as that of the neighbouring Chalk.\*

The porosity of the Kentish Rag gives great facilities for draining retentive soils above it, as the following account of a farm at Sevenoaks will show. "Owing to the greater part of the farm being naturally dry, very little draining has been required, but that little has been effected by the following rather ingenious method: wells have been sunk to the depth of from 20 to 30 feet, at which distance from the surface the Kentish

---

\* The highest point reached by the Chalk in Kent is within half a mile of the county boundary, just east of Betsoms Hill Farm, north of Westerham, and nearly opposite the highest point of Lower Greensand; the summits differing by only two feet—a remarkable coincidence. The highest point of the North Downs is a little east of Flint House, near Woldingham, Surrey, and just three miles west of Betsoms Hill Farm: this is 876 feet.

Rag, as it is called, or stone, is usually found. These wells receive the water from the different drains which empty into them, and as the Kentish Rag is of great extent and thickness, and very porous, the wells are capable of receiving any quantity of water which may issue from the drains. Part of Knole Park has been drained upon the same principle, and could have been drained in no other way without a very great expense, as from the formation of the surface much difficulty would have been found in obtaining a fall. The wells are arched over at top, or filled up with stones, so that a stranger walking over the farm would not be aware that any draining had been accomplished.”\* This power of taking away water is possessed by all porous rocks, especially limestones, that are not themselves saturated; and is frequently made use of in a similar manner to that just described. Water on clayey land over chalk may always be readily discharged, at any point, by such means. In Hertfordshire chalk is got by sinking shallow pits through the clay in various parts of the field, and these pits are afterwards used as outlets for drains.

From near the borders of Surrey, westwards, an important change occurs in the composition of the Hythe Beds. The Kentish Rag is gradually lost, and the division assumes the sandy character which distinguishes it in West Surrey. Between Limpsfield and Dorking its outcrop is narrowed; the ground is of moderate elevation, only a few places attaining to 500 feet, and the highest being under 600 feet.

Immediately on the west of Dorking the character of the country changes. The Lower Greensand escarpment shoots suddenly out for three miles beyond its general line east of that place, and forms the lofty range of hills, of which Leith Hill is the summit (967 feet).† This district is highly picturesque, and is deeply furrowed by narrow valleys which, commencing near the crest of the escarpment, run northward, and reach down to the Atherfield and Weald Clay: hence they are plentifully supplied with water. The northern half of the area is cultivated, but the higher land, near the escarpment, is mostly either in open common or woodland. The ground sinks towards the valley through which the southern branch of the River Wey escapes, but rises again rapidly to the high land of Hascombe and Hambledon. This valley forms the line of communication

---

\* “Account of Hall Farm, near Sevenoaks, Kent.” ‘Journal of the Royal Agricultural Society,’ vol. viii., p. 34.

† This and some other heights given in this paper do not agree with those generally taken for the points mentioned. They are, however, more correct, being the result of recent observations by the Ordnance Survey. All are calculated from *mean sea level*.

between Guildford and the Weald; through it run the Surrey and Sussex Canal, the railway from Guildford to Horsham, and the turnpike-road from Guildford; the last divides into two on reaching the open Weald Clay country. Over the lower country, near the Wey, about Godalming, there is a good deal of fertile loamy land on the Hythe Beds, but the southern and higher portion still retains its sterile character. This sterility reaches its maximum on the high-land of Hindhead, the summit of which is 894 feet. Here there is little but fern, furze, and heath, with some plantations. A farmer, looking merely to the apparent value of the soil, might be inclined to share Cobbett's opinion of these "rascally heaths." To Hindhead he had a very strong aversion, declaring it to be "certainly the most villainous spot that God ever made. Our ancestors do, indeed, seem to have ascribed its formation to another power; for the most celebrated part of it is called the 'Devil's Punch Bowl.'"\*

Although these heaths are, for agricultural purposes, of small account, yet for wild beauty they are unequalled by any district within easy reach of London. Very extensive views are obtained from high points near the crest of the escarpment, which, being of greater height than the Chalk escarpment, allows the entire width of the valley of the Thames to be seen. The view from Leith Hill embraces at least eleven counties, and extends as far north as Dunstable Downs, forty-nine miles distant in a direct line.

In tracing the Hythe Beds southward towards Petersfield, and then eastward through Sussex, the character of the land remains for a while much the same. The lower part of the division, that which occurs nearest the escarpment and forms the highest ground, is least productive; the subsoil is chiefly of sand and sandstone. Towards Petworth, however, the beds become slightly more calcareous, and, apparently in consequence thereof, the land more fertile. Thus, whilst the upper sands, or Folkestone Beds, still retain their partially sterile character, the lower division improves in an easterly direction.

Just west of the river Adur the Greensand country makes a curious recession towards the Chalk, the shape of which will be best understood by referring to the map, remembering that the Weald Clay forms low ground, and that the Lower Greensand is characterized by hills, which are here of less height than usual.

From near the London and Brighton Railway, eastward, the

---

\* 'Rural Rides.' 1830, p. 66. This volume contains a great deal of information concerning the agriculture of the Weald.



Lower Greensand loses its marks of division, and with this its hilly character; so that in looking from the Weald towards the Chalk there is no marked feature of the ground. It still, however, has a slight rise from the clayey beds on either side. This light land averages somewhat over half-a-mile in breadth, spreading more widely at Chalvington and Selmeston. It is here a soft sand, yellowish and greenish, and forms a good soil.

Before leaving the Lower Greensand it may be well to say a few words on its water-bearing qualities. Setting aside the Atherfield Clay, which, as regards such questions, must be ranked with the underlying Weald Clay, we find that, with the exception of the inconstant middle division, the beds are highly porous and absorbent. The greater part of the rain falling on them sinks underground, and is thrown out as springs along the face of the escarpment, or in those valleys which either reach down to the clay or touch the line of saturation. Hence, with few exceptions, due to local causes, water may readily be got by wells.

The great abundance of the springs in the Hindhead and Leith Hill district, and the purity and softness of their waters, have led to proposals for partially supplying London from this source. Many analyses of the waters have been made: and the following are selected from those by Professors Graham, Miller, and Hofmann.\*

	Vellwood, 1½ Mile from Haslemere.	The Punch Bowl, near the summit of Hindhead.	Barford millstream.	Springs at the Moors, Gosford House.
	Grains in an Imperial Gallon.			
Carbonate of Lime .. .. .	..	..	2·39	8·31
Sulphate of Lime .. .. .	0·86	0·59	0·40	2·48
Silicate of Lime .. .. .	0·45	1·00	..	1·17
Silicate of Magnesia .. .. .	..	0·30	..	..
Carbonate of Magnesia .. .. .	trace.	..	0·27	0·60
Chloride of Sodium .. .. .	0·87	0·74	0·94	1·40
Sulphate of Soda .. .. .	0·44	0·04	..	0·22
Chloride of Potassium .. .. .	..	..	0·03	..
Sulphate of Potassa .. .. .	0·40	0·09	0·20	0·77
Silica .. .. .	0·93	0·10	0·72	..
Iron, Alumina, and Phosphates	..	0·02	0·08	0·08
Organic matter .. .. .	1·24	1·30	1·05	0·95
	5·19	4·18	6·08	15·98
Solid residue obtained on evapo- ration .. .. .	5·17	4·34	5·65	15·75
Free Carbonic Acid .. .. .	trace.	trace.	trace.	trace.
Hardness .. .. .	1·86	2·45	2·70	10·8

It will cause no surprise that rocks which yield so small a

\* Parl. Reports, 1851, and 'Quart. Jour. Chem. Soc.,' vol. iv., p. 375.

quantity of soluble matter to water flowing through them should produce a barren soil. The spring at Gosford House, which contains the most, is comparatively pure. The springs are deep-seated, the temperature of the water varying from 50° to 52° Fahr., and on this account (*viz.*, their warmth in winter) they would be available for irrigation; but the quantity of mineral matter is small for this purpose, that at Gosford House would probably be of most service. The value of hard water from chalk springs is well known in irrigation; that from the Kentish Rag is also good. The fertilizing agent here is probably bi-carbonate of lime, but it does not appear that success in irrigation always depends upon the quantity of lime contained in the water. The question requires further research, and few subjects touching alike Agriculture, Chemistry, and Geology give greater promise of interesting results. The investigation, to be complete, should include analyses of rock formations, their overlying soils, and water issuing therefrom, whether as springs from the former or by drains from the latter; together with the effect of such water on soils of known composition.

Prof. Way's experiments on "The Composition of the Waters of Land-Drainage and of Rain" \* were in great part made upon water from Farnham, supplied by Mr. J. M. Paine. The fields were chiefly in Gault clay or on gravel over Gault.

#### WEALD CLAY.

This formation, though occupying a large area, presents few points of interest. Nearly always it forms a flat plain, through which the rivers wind in broad alluvial flats. From the small amount of fall which the rivers have in traversing it, they are subject to strong floods. This is especially the case with the Teise, an eastern tributary of the Medway.

The soil of the Weald Clay proper is a stiff yellowish clay, very poor in places, but generally, like most other clays, capable of great improvement. In places there are lines of lighter soil caused by the outcropping of thin beds of sand, but they are not of great extent and do not affect the general character of the district, which is *stiff land*, excepting where overlain by alluvial loams and gravels. These sand beds, however, are important in providing water through the district. Wells sunk to catch a sand bed are often "artesian," the water rising to or near the surface. This is owing to the dip of the beds: if the *outcrop* of the water-

\* 'Journal of the Royal Agricultural Society,' vol. xvii., p. 123. Professor Way also employed Mr. Paine's soils in some of his researches upon the absorptive properties of soils. They were taken from the Gault, London Clay, and Gravel. See vol. xv., p. 495.

bearing bed is as high as the well the water will rise near the surface, unless interfered with by faults, or by streams cutting down into the strata, and so lowering the water-level. This general principle is applicable to all districts in which alternations of porous and retentive beds occur with a regular dip.

Besides the sand beds, there are layers of limestone full of shells, known indifferently as Sussex, Petworth, or Bethersden marble. This stone was formerly often dug for ornamental purposes, and has been much used in church architecture. The fine tower of Tenterden Church ("Tenterden steeple" of the legend) is built of it. It is also used as pavement in the choir of Canterbury Cathedral. At present it is occasionally got for road-stones. I am not aware that it is ever now burnt for lime; chalk-lime being universally in use throughout the Weald. To one other purpose it is applied—in forming paved paths by the sides of the roads in clay districts. Formerly these were the only channels of communication between places in winter; the roads were often impassable, and goods were carried on pack-horses along the paths. In the clay districts of the Hastings Beds slabs of calcareous sandstone are often used for this purpose; and a somewhat similar bed, known as "Horsham Stone," is thus used around Horsham.

Strange tales are told by old writers of the state of the Wealden roads. We read, not without slight incredulity, of heavy oak-timber being *years* performing the journey from the interior of the country to the river at Tunbridge. Macaulay adduces this district as an example of the bad state of inland communication, and relates that Prince George of Denmark, when journeying to Petworth in wet weather, "was six hours in going nine miles; and it was necessary that a body of sturdy hinds should be on each side of his coach, in order to prop it. Of the carriages which conveyed his retinue several were upset and injured. A letter from one of his gentlemen-in-waiting has been preserved, in which the unfortunate courtier complains that, during fourteen hours, he never once alighted, except when his coach was overturned or stuck fast in the mud."\* More amusing, if less authentic, is the tradition which tells of Henry VIII. getting mired on the road to Hever, when visiting Anne Boleyn.

The bad state of the Wealden roads in olden times was partly due to the heavy traffic to and from the ironworks, of which there were many in Kent and Surrey, but far more in Sussex. So great a nuisance had this traffic become, that Acts were passed in Elizabeth's reign, providing that all who used the roads for this purpose should carry materials for repairing the highways.

Suitable stuff for road-mending was then hard to get, there

\* 'History of England,' vol. i., p. 373 (of 12th edition).

being but little of any value in the Weald. Now, chalk-flints and flint-gravel are largely used; whilst near the coast, and in districts near the Rother, shingle is taken from the shore in large quantities. The old slag heaps of the ironworks afford excellent road material, but the quantity is small. Wherever limestone-beds occur they are sought after and dug for roadstone, but when used alone the roads are dusty in summer and soft in winter. Flints, either alone or mixed with other material, form the best roads. It is important that the flints should never be used fresh from the chalk-pits; they are then brittle and far less serviceable than when suffered to lie and weather for a few years, by which means they acquire "toughness." The very best flints are those picked off the fields. Very many cross-roads in the Weald, and still more of the farm-roads, are simply mended with soft sandstone—the hardest that the neighbourhood affords, no doubt, but quite useless for the purpose.

To return to the Weald Clay. While stiffness and flatness are its prevailing characters, there are parts that are fairly hilly and others which afford lighter soils. Both chiefly occur where the clay is overspread with gravel. Some land north of Tunbridge is undulating, the higher ground being capped by gravel. East of Tunbridge occurs the great spread of loam, which produces the hop-soil for which the district is celebrated. Sometimes there are beds of fine gravel, but the greater part is a rich loam, yielding a soil of great depth.\*

Of superficial beds covering the Weald Clay, those of the Medway are the most important, whilst the Mole and Wey have considerable areas thus covered. Of old alluvia of the River Stour, only small and unimportant patches remain on the Weald Clay. Those of the southern rivers seem to be less important than similar deposits in the north of the Weald.

Over many parts of the Weald Clay the gravel occurs in hard masses, cemented by iron. These are locally known as "ragstone;" and one occasionally hears of "ragstone soil." It is important to bear in mind that this in no way resembles the ragstone soil of the Maidstone district.

#### HASTINGS BEDS.

Most people who are personally unacquainted with the Weald have an idea that it is all, or chiefly, a stiff soil. This is true of the Weald Clay flat, but not of the inner and upland country, o

---

\* The hop gardens of Hadlow are commonly described as on Weald Clay, and so they are according to most geological maps; but, in fact, the majority have nothing to do with Weald Clay, being separated therefrom by many feet of gravel and brick earth.

which we have now to speak. Considerably more than half is light land. Indeed the name until lately used for the rocks of the district has been "*Hastings Sands*." This was misleading, as they contain somewhat thick beds of clay.

Another erroneous notion, commonly held, is that the Weald is a *valley*; we frequently read of the "*Valley of the Weald*." Again, this is true of the Weald Clay, but wholly false if the term "*Weald*" includes, as of course it does, the central area. Wherever the Hastings Beds crop out from under the Weald Clay, they do so with gently rising ground, not a steep slope. This rise continues towards the centre of the country until the ground attains heights considerably over the *average* elevation of the Lower Greensand. The chief points are Crowborough Beacon, 803 feet; Brightling Down, 636 feet; Fairlight Down, 589 feet; all in Sussex. Goudhurst, 487 feet, in Kent. These points are all on sand.

Commencing our survey of the district at its western end, we should note that on the ground coloured as Weald Clay around Horsham there is more light land than is usual over that division. This is owing to the outcropping of the "*Horsham Stone*." But although the soil is light where this stone forms the actual surface, yet the area over which this bed occurs is perhaps more wet than dry. It has, therefore, been included in Weald Clay on the map. On the large sheets of the Geological Survey it is shown by a distinct colour, the whole being included in Weald Clay.

Immediately to the east of Horsham the light land sets in, widening in area eastwards, and occupying the whole of St. Leonards Forest; unless some of the deep "*gills*"\* reach down to the lower clays. This "*forest*" still deserves its name, much timber remaining in it. The ground is high, compared with the neighbouring Weald Clay, but much less so than in the country further east.

Over Ashdown Forest the land is nearly all light. The little of the original forest which remains is chiefly in the steep-sided gills. Over the higher land are some modern plantations, some of which are in circular clumps and are visible for many miles. A great deal of this land still remains unenclosed. The soil is very poor and the situation bleak. A considerable area of this forest is over 500 feet in height, whilst the highest point of the Weald (Crowborough Beacon, 803 feet) occurs within its boundary.

The next important spread of sandy land is that around Cross-in-hand, Heathfield, and Brightling. Here also there is much

\* This word is quite characteristic of the Weald, and denotes a steep-sided wooded valley. I am not aware that it is used in the neighbouring Greensand district. It is in common use in parts of Yorkshire and the northern counties.

land unenclosed, but far less than on Ashdown Forest. The soils of both areas are much alike.

The fourth great sandy area is that along the borders of Kent and Sussex, south-east of Tunbridge Wells, separated by a band of clay country from the light land, also of considerable extent, north of Cranbrook. The greater part of this area, however, is very different in character from the Ashdown and Heathfield districts. The land, though still light, is of much better quality. In the absence of analyses of rocks and soils from these different districts, there appears no sufficient reason for such variations. It is true, the sands belong to different horizons of the series; those of Heathfield and Ashdown Forest are the "Ashdown sands," as are also the comparatively sterile lands of Fairlight, near Hastings. The light land around Cranbrook is almost entirely composed of Tunbridge Wells sand—the uppermost member of the Hastings Beds. But there is a great similarity between these beds, and no one, even when most minutely acquainted with the country, could possibly tell from inspecting a quarry or sand-pit to which horizon the bed exposed therein should be referred. There may be, and often are, quite local characters which are of service to a geologist in mapping the country; but I am not aware of any well-defined character by which the Tunbridge Wells sands can, as a whole, be distinguished from the Ashdown sands. Possibly the chief cause of the difference is height above the sea. The sterility of the Sussex sands has been ascribed to the *iron* they contain; but I doubt whether the most sterile soils are more ferruginous than others.

The character which most distinguishes the Wealden sands and sandstones is their extreme *fineness*. We rarely meet with sands as coarse and sharp as those of the Lower Greensand. The coarser sands generally occur as rock-beds, such as are well known in the neighbourhood of Tunbridge Wells. This fine state of division makes it less easy for water to pass through the sands, and they, therefore, have, when wet, some of the characters of clay. Rushes very frequently grow in abundance over land in which analysis would show but a small quantity of clay; but there is often more clayey matter, not making the land in any sense stiff, but only a sandy loam, and this, together with the fineness of the sand, gives the land over it a very wet appearance. It is a complaint that sheep are fed with difficulty on such land, which has, therefore, many of the disadvantages of clay without its strength.

The Tunbridge Wells sand contains some subordinate beds of clay, the chief of which is most fully developed around East Grinstead, and is called Grinstead Clay. There it resembles the Wadhurst Clay in character. Further east, however, what

seems to be the same bed is a light-coloured clay, often variegated with red; it is there thin, and forms no great extent of surface. Both Tunbridge Wells and Ashdown Sands have other and thinner beds of loam and clay, which give a local wetness to the soil. Loam seems to be more frequent in the area west of Uckfield, but not in sufficient quantity to make much of the land stiff.

The Clays of the Hastings Beds (Wadhurst Clay and Grinstead Clay in its western range) are, when freshly dug, thinly bedded shales (locally "marl"), which, on exposure to the weather, very soon become a soft clay. It is generally yellowish, sometimes of a darker hue, but rarely of the deep brown colour which distinguishes the weathered London Clay. In all its characters it resembles the Weald Clay; but has this important advantage, that it never occurs as flat plains, but always makes more or less undulating ground. Sand predominates in the Hastings Beds, as already stated, and the district has that general character of feature which sand produces. This hilly nature of the ground gives abundant facilities for drainage. The Wealden clays are remarkable for the extent to which they shrink and crack in dry weather.

In the Wadhurst Clay there are occasionally thin beds of sand, unimportant agriculturally, but of use, at times, in yielding water at a less depth than if the Ashdown Sand had to be reached.

The map shows the general distribution of the sand and clay beds, and to describe their range in detail is quite unnecessary. The lowest beds of the district, however, deserve a separate notice.

The Ashburnham Beds occur in two areas: the one around Hastings, where they consist of mottled clays, with sandstone; the other to the north and north-east of Battle, where they contain, in addition, many beds of limestone. They form a wet soil, stiff as a whole, but less so than the Weald and Wadhurst Clays.

The limestone beds crop out in a long valley north-east of Heathfield, and again, further east, nearer the South-Eastern Railway. The works were, some years ago, of great extent, but are now abandoned. The best and fullest published account of them is contained in Young's 'Survey.'\* He states that the Earl of Ashburnham was then "the greatest lime-burner in all the kingdom." At present the limestone is dug for roads, but is not extensively burnt.

The Wadhurst Clay was the main source of the ironstone

---

\* Pp. 13 and 205 of 8vo. edition, 1808.

which, from the earliest times, was smelted in the Weald. This was, at one time, the chief iron-district in England, and to the great extent of the trade is owing the disappearance of timber, which entirely covered the country. The ironworks gradually declined from the time of the introduction of coal. Gloucester Furnace, at Lamberhurst, was the last worked in the north-eastern parts; it was put out at the end of the last century. Ashburnham Furnace, in Sussex, continued at work till the year 1828.

It is to these ironworks that we owe the great number of large ponds which dot the country everywhere. A dam was thrown across a valley, and the water thus stored employed in driving hammers, &c. Large numbers have been drained, whilst others still serve as ponds for corn or other mills.

#### MARL.

Any person travelling through the Weald must have been struck with the vast quantity of pits, generally overgrown and holding water, which occur over the clayey districts; chiefly where the clays border on the lighter lands. Out of these pits *shale* was got, which is locally termed "marl." At present it is scarcely ever dug, a general impression prevailing that the process is useless, and not without good reason, for the shale contains little or no lime or other manure. It is said to have been applied to light and stiff land alike; for the latter it would only be equivalent to deep-ploughing, to which the true Wealden farmer is generally averse. On some light soils it might have a beneficial effect.

The custom of "marling" is of considerable antiquity in the Weald. Gervase Markham, writing in 1683, says that it had quite gone out of use till within twenty or thirty years before that date, but that trees 200 or 300 years old were then growing in old marl-pits. This author's odd remarks may be interesting to some readers. "Marl is," he says,\* "a fat, oily, and unctuous ground, lying in the belly of the earth, which is of a warm and moist temperature, and so most fertile; seeing that heat and moisture be the father and mother of generation and growth; how be it, this is not a pure and simple marrow (as that which lieth in our bones), but a juyce or fat liquor, mingled with the earth, as is the fat which lieth mixed and dispersed in our flesh, so as the one may be drawn away, and the other remain as it shall anon appear unto you.

"Four sorts of *marle* be found in this Weald, known asunder

\* 'The Enrichment of the Weald of Kent,' p. 5. 4to. London.



by the different colours, and thereby also differing in degrees of goodness one from the other : for there is a grey, a blew, a yellow, and red Marle, all which be profitable, if they be earthly and fat, or slippery as soap : and most times little worth, if they be mixed with sand, gravel, or stone. So the blew is reported the best, the yellow the next, the grey the next, and the red less durable than the other three ; and yet it is thought the red is the better, if it be found upon the blue, or others.”

It is probable that “marl” continued in constant use from Markham’s time till about sixty years back.

### MARSH LAND AND ALLUVIUM.

There are two alluvial districts of considerable extent coming within the boundaries of the Weald : they are Pevensey Level, in Sussex ; and Romney Marsh, chiefly in Kent. Of these the latter is by far the larger. It is bounded on the north by the rising ground extending from Hythe on the east, by Appledore to Rye. Long arms of marsh land extend up the Wealden country, bordering the river Rother and its tributaries. Romney Marsh is in appearance, though perhaps not in fact, the *delta* of the Rother. It is bounded on its seaward side by great tracts of shingle, and when not thus protected is faced with sea-walls.

The term Romney Marsh is generally applied to the whole alluvial flat (not the valleys leading into it) ; but, in fact, the name really belongs only to that part of the marsh east of the road from Appledore to New Romney. The other districts are known as Walling Marsh, Dunge (or Denge) Marsh, and Guildford Level.

Nearly the whole of this tract is below the high-water mark of spring tides. The lowest part lies just to the north-east of Appledore, and is called the Dowls. This is  $13\frac{1}{2}$  feet below high-water mark. Romney Marsh proper is that part which was earliest reclaimed by the Romans. Some land towards the central part of this is arable, but by far the larger part is pasture. Some of the land which was reclaimed later than Romney Marsh is arable ; this lies somewhat higher than the older land.

The soil is peaty in part, but generally a rich alluvial clay or clayey loam ; and there are some patches of lighter soil. Clay generally occurs below the peat, but the underlying stratum all over the marsh is a loose sand. “Dunge Beach is the widest spread of shingle in this area, being three miles long and from one to three miles wide, in some parts absolutely bare of vegetation for hundreds of acres, and in others sparingly dotted with

furze bushes and broom. Roads there are none, only a few tracks, and it is altogether a most desolate-looking place. Those who have to cross the shingle usually put on a pair of 'baxters,' or small flat pieces of wood with a leathern loop for the foot. They are used with a peculiar sliding gait, and make the walking much more easy."\*

Pevensey Level much resembles Romney Marsh, save in extent. It, too, is pasture land; lying low, and protected by a broad spread of shingle, which stretches along the coast from Eastbourne eastwards.

### HOPS.

In this essay the author has avoided questions touching upon agriculture proper, but a few words upon a crop which pre-eminently distinguishes the area under review may not be out of place.

There are four districts within the Weald in which hops are more largely grown than elsewhere. The smallest in extent is that around Farnham. They are grown chiefly upon the marly and soft siliceous soils of the Upper Greensand,† but also occasionally upon the neighbouring Gault, either when bare or overspread with gravel. The hops from this district always command a high price. Some of the lands now growing this plant have been hop-gardens for a very long time; the "Heart Gardens" at Farnham "have been in continuous cultivation ever since the first introduction of hops into England, or, at any rate, for fully 300 years."‡

The next district in quality of produce, and surpassing the former in extent, is that of the Medway valley, on the ragstone soil; of which sufficient has been said in describing the Lower Greensand area. The hop-gardens, however, extend along the face of the escarpment, east and west, flourishing extremely well on the outcrop of the Atherfield Clay, and the débris of the ragstone hill. The Maidstone district thus joins on to that of Hadlow and Tunbridge.

\* Drew, Mem. Geol. Survey, Sheet 4, p. 18. This memoir contains a minute account of the formation and present character of Romney Marsh.

† Writing of the Upper Greensand of Oxfordshire, Mr. C. S. Read says: "The extraordinary luxuriance of the wild hop seems to indicate that it is the natural soil of that plant, and peculiarly adapted for its growth" ("Farming of Oxfordshire," 'Journal of the Royal Agricultural Society,' vol. xv., p. 195.) It is strange that hops are not more cultivated on the outcropping of the Upper Greensand north of London. There were only 9 acres grown in Oxfordshire in 1866, 2 acres in 1867 and 1868, and none in 1869.

‡ See article, "Hop" (by Mr. T. M. Paine), in Morton's 'Cyclopædia of Agriculture.'

Many hop-gardens are planted on the bare Weald Clay soil, but the greater number occur over the deep loams which border the Medway east of Tunbridge. From this flat country the hop-gardens stretch up the rising ground of the Hastings Beds, and thus connect this district with the fourth, or that of the Hastings Beds proper. This is of wider area than any other, but in no part of it do hop-gardens occur so thickly as near Hadlow and Maidstone. They are most common along the bottoms or slopes of the larger valleys, which have a general east and west direction. The streams running in these valleys unite to form the River Rother.\* The soils of these valleys much resemble that of the Hadlow district, and the same kinds of hops are grown. It is a deep rich loam, either the washings of the valley sides, brought down by rain, or old alluvia of the streams which now flow along the bottoms.

The hop-gardens, however, are not confined to the valleys, but extend up the slopes and over the higher ground; they are found on all soils, even on stiff clays where sufficiently drained. Hops are not equally distributed over the Hastings Beds. They occur chiefly over the northern, central, and eastern districts, and there are also a good many on the south; but westwards they become less common, comparatively few being met with west of Uckfield. The map of the soils accompanying this paper shows that the clayey beds of the Hastings series occupy a considerable area over the hop districts. It is not that hops are chiefly grown on clay, for, as just stated, they prefer a deep loamy soil, but it is not unlikely that, as far as the Weald is concerned, the *alluvia of clayey districts* suits them best.

Shelter from high winds is essential for hops, and, where not naturally protected, the hop-gardens are frequently bordered by tall hedge-rows on the windward side, or by rough wooden walls of spare hop-poles: such protections are called "lews."

The varieties of hops grown in the Weald are of coarser quality than those of the Farnham and Maidstone districts; but much larger crops are often obtained, and the hops are less liable to the "mould," which often rapidly destroys the most promising crops.

The hop-gardens of the Weald are not so continuous upon the same land as in the Farnham district. Ten or twelve years are said to be their average duration; yet one occasionally hears of some that have remained such for a much longer time.

The 'Agricultural Returns' for 1866-71 give the following numbers as the acreage under hops in those years:—

---

\* There is another Rother in West Sussex, flowing from west to east, over the Lower Greensand, into the Arun.

	1866.	1867.	1868.	1869.	1870.	1871.
Kent .. .. .	36,367	40,762	41,087	38,606	37,490	36,672
Sussex .. .. .	8,488	9,989	10,107	9,613	9,445	9,412
Hereford .. .. .	4,763	5,335	5,564	5,736	5,798	5,998
Hants .. .. .	2,119	2,992	2,517	2,536	2,530	2,625
Worcester .. .. .	2,321	2,421	2,430	2,522	2,606	2,672
Surrey .. .. .	1,881	2,193	2,208	2,209	2,152	2,128
Remaining Counties .. .. .	623	581	542	561	559	515
Total for England .. .. .	56,562	64,273	64,455	61,785	60,580	60,022
Total for Wales .. .. .	14	7	33	6	14	7
Total for England and Wales	56,576	64,280	64,488	61,791	60,594	60,029

Of the total acreage under hops in England, 63 per cent., or nearly two-thirds, are in Kent alone. Whilst the four south-eastern counties (Kent, Sussex, Surrey, and Hants), have together 86 per cent., or nearly nine-tenths of the whole.

In taking a general glance over the district it must be confessed that the points which strike one as most characteristic of the Wealden area proper, as an agricultural district, are not to its credit. They are chiefly these:—A superabundance of hedge-row timber; broad strips of underwood, called “shaws,” in place of hedges; small fields, and badly-kept roads. Concerning the last, there is less reason for complaint than formerly; but with many there is an enormous waste of land from their great width.

Possibly, if the hedge-rows were cleared of timber and the useless “shaws” cut down, there would still remain too much wood in the country for it ever to rank as a first-class wheat-district. Woodlands, as is well known, cause a damp climate, increase the rainfall, and lower the summer temperature—all unfavourable conditions for the growth of wheat; but a very great improvement might be made by the changes indicated. It has often been said that hop-culture has a most injurious effect upon Wealden farming, and there can be no doubt of its truth. High manuring is absolutely essential to success, and many farmers expend their energies on the cultivation of this most precarious crop, content at the same time to reap poor yields of oats from land that, with better management, would give very fair crops of wheat.

The following is a recent notice of the country in the Society's Journal.\* The district referred to is Ninfield, near Hastings, by no means the most unfavourable specimen that could be

\* ‘Report on Steam Cultivation,’ *N.S.*, vol. iii., p. 142.

chosen:—"The whole district appeared to us to be sadly in arrear, little or no spirit being observable in landowners or their tenantry. Rent ranges from 10s. to 25s. an acre, and yet we found that, where the land was well farmed, an average yield of wheat was 4 qrs. per acre. We were told of tenants being under covenants to reap their white-straw crops with a sickle."

There are many farmers in various parts to whose land none of the foregoing complaints apply; but changes take place very slowly in the Weald, and it will probably be many years before their example materially changes the character of the district.

Besides the authorities given in the foregoing paper, the following papers in the 'Journal' of this Society may be referred to as treating of the area under review:—

1848. Rutley, S. 'On the Management of Hops.' Vol. ix., p. 532.  
 1850. Farncombe, J. 'Report on the Farming of Sussex.' Vol. xi., p. 75.  
 1853. Evershed, S. 'On the Improved Method of Cropping and Cultivating Light Land' (Surrey). Vol. xiv. p. 79.  
 1858. Hawes, S. 'Notes on the Wealden Clay of Sussex, and on its Cultivation.' Vol. xix., p. 182.  
 1860. Heathorn, R. 'On a Course of Cropping adopted in Kent' (Gault and Lower Greensand, at Aylesford). Vol. xxi., p. 385.

*Note on the Map.*—The map has been reduced from the 1-inch maps of the Geological Survey, which are the Ordnance Survey sheets geologically coloured. Roads and canals are omitted. There is no hill shading; but a much more accurate idea of the contour of the country may be obtained from this map than by the ordinary method of shading hills and valleys.

The uncoloured area adjoining the Upper Greensand is chalk, which rises in a steep hill or escarpment from the Greensand. The crest of this escarpment and the corresponding line along the Lower Greensand escarpment is everywhere the highest ground of the district. The area coloured as Weald Clay is chiefly a long flat plain. The Hastings Beds are rising ground, the highest parts of which are the sand districts described on p. 259. By bearing these facts in mind, and remembering further that the streams make deep and steep-sided valleys in the hard beds, but only broad and unimportant depressions in the clays, a sufficiently accurate idea of the shape of the country will be obtained.

---

XIII.—*On Swedish Butter Factories, as adapted to Small Farm Districts.* By M. JUHLIN-DANNFELT, Superintendent of the Royal Agricultural College at Stockholm, and Honorary Member of the Royal Agricultural Society of England.

As already stated in my last communication, the Mälar-Lake Dairy Company, Limited, the first dairy company in Sweden, was founded upon the principle of purchasing milk for cream-setting; the cream obtained at the district milk-houses was

transported to butter factories, while the skim-milk was either sold in the capital in its crude state, or made into cheese at the milk-houses.

At the commencement of the operations of the Company great difficulties were experienced in exercising proper control over the treatment of the milk at the several receiving-houses; and they naturally increased as the operations of the Company became more extensive. The books having been balanced at the close of the first three months' operations, on the 31st of December, 1870, it was proved that the results differed at the various milk-houses—at some they were profitable, at others disadvantageous. The latter result had probably been caused, partly by disregard of the rules for the treatment of the milk after delivery, and partly by insufficient check as to the quality of the milk delivered. The Company therefore decided that its operations should be confined to the purchase and working of cream—not of milk—leaving it to the producer or purchaser of the latter to utilise the skim-milk in the manner which, under different local circumstances, he might consider most profitable.

This step has proved to be very advantageous to all parties concerned. It has decidedly promoted the further development of the factory-system, and at the same time opened the way to a useful and profitable branch of industry to those who occupy themselves with collecting pure milk from the smaller farmers—whose produce is too limited to allow the cream obtained from it to be treated in the manner which will make it saleable to the Dairy Company,—or from such larger producers of milk as do not care to take the pains necessary for obtaining the cream, or for the further preparation of the skimmed milk.

*Collection and treatment of the Milk.*—Experience has proved that cream cannot generally be kept longer than fifty hours in the summer, and from seventy to eighty hours in the winter, without affecting the quality of the butter. The butter factories of the Mälars Lake, and other companies, do not receive less than 10 “kannor” (=5·76 imperial gallons) at the time, for reasons mentioned below. The consequence is, therefore, that a farmer whose herd does not number at least 20 cows cannot deliver the cream direct to the Company. The greater part of the country being divided into small farms, on which the number of cattle does not reach this minimum, the Company has established milk-houses in large villages or other suitable localities, thus giving even the smallest farmer an opportunity to dispose of his produce advantageously.

The milk is carried, or otherwise transported, to these places every night and morning, immediately after milking, from the farms not more than 1½ English mile distant. It is first mea-

sured and then skimmed by the woman in charge of the place, who enters the quantity delivered. According to her book the farmers receive payment, at the end of every month, for the quantity of milk delivered during the previous month. When the milk is measured, a sample is put into a graduated cylinder of glass, and is left for cream-setting with the remainder of the milk, so as to give an idea of its quality. This is the only control exercised over the honesty of those who deliver the milk, and although it is not very satisfactory, it has hitherto generally answered its purpose.

The milk-houses in which the skimmed milk is not further prepared consist of one room or boarded shed, large enough for the pools or cisterns in which the milk is cooled; next to that is a kitchen with a boiler for cleaning the vessels, as well as one

Fig. 1.—Plan of a Milk Receiving-house.

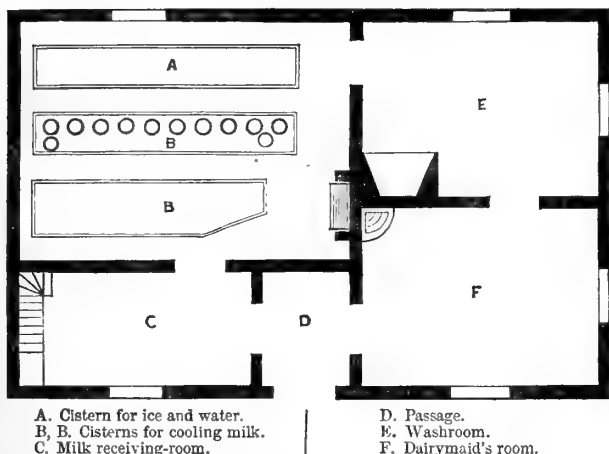

room for the dairy-maid. When cheese is made, another room is required for pressing and salting, as also a cheese-store, and a smaller room for keeping the ingredients necessary for this process. The kitchen, in which the curding is done, and the room or rooms inhabited by the dairy-maids who receive and prepare the milk, must also be larger than in the previous class.

These houses are generally very plain, and, as a rule, are arranged in buildings erected for other purposes, but adapted to this. The rent varies from 50 to 200 rix dollars (= 3*l.* to 10*l.* sterling) per year. Fig. 1 represents the ground-plan of a building erected by the Company close to a railway-station, for the reception of milk only, the cost of which, with a shed for storing ice, was altogether 144*l.* sterling.

The persons who, as above stated, take charge of the purchase of milk, as arranged by the Company, pay as rent for the houses, which belong to the Company, an amount equal to 6 per cent. interest upon their cost; and for others the whole amount of the rent charged to the Company.

For cooling the milk, square cisterns or oval tanks are used, both being 24 inches in depth. Their other dimensions depend upon the quantity of milk to be strained at one time, and upon other circumstances. Cisterns manufactured at the carpenter's shop of the Company are made of planks 2 inches thick, and inside 9 feet long and 3 feet wide. Such a cistern is large enough for cooling about 200 "kannor" (= 115.2 imperial gallons) of milk. A loose grate, provided with a 3 to 4 inch wooden wedge is fastened to the bottom inside the cistern. The pails for setting the milk are placed upon the grate, thus allowing the ice-water perfect access under the pails.

The milk-pails, or tubs, are made of iron or steel-plate, and thoroughly and carefully tinned inside and out. Originally, when the milk was cooled by cold water from wells, these pails had a diameter of 18 inches, and a depth of 24 inches. By long and careful experiments it has been ascertained that the more speedily the milk is cooled down, the more completely is the cream separated from it. The consequence is, that not only is much colder water now used for cooling the milk, but the pails for setting it have also been reduced to the smallest diameter, consistent with the other management of the milk, namely, about 9 inches, thereby, with a depth of 20 inches, holding about 6 "kannor" (= 3.5 imperial gallons). In order to be able to use the original pails, their bottom has been taken away, and the sides pressed together, giving the pail an oval shape, with a small diameter of seven inches, and providing them with new bottoms. The cooling power of these pails has thus been greatly increased, and many farmers prefer them to the smaller cylindrical ones, as being comparatively cheaper, and the milk in them easier skimmed.

Besides changing the form of the pails in which the milk is set and cooled, other attempts have been made to quicken the cooling by using iced-water instead of well-water. The temperature of the well-water is not lower than that of the soil, or from 42.8° to 44.6° Fahr., whereas the temperature of water in which ice, chopped in small pieces, is permitted to melt, may easily be reduced to 35.6° or 39.2° Fahr. Cold wells are not always to be found, but, on the contrary, are very rare in some districts, whereas ice may be had in our northern country generally at a very small expense. The ice-water-method is, therefore, now used at all the milk-houses, as well as by nearly all the farmers who furnish the Company with cream. While constant change



of the well-water, where such is used, is required, in order to retain a low temperature, the ice-water does not require to be changed more than a few times every year. The surplus water arising from the melting of the ice is let out by a small pipe placed at the upper edge of the water-tank.

The ice is stored in pyramidal piles placed in a shed, or, more generally, in the open air, covered with sawdust, tanning-bark, peat-soil, or other material which does not conduct heat. As small spaces as possible are left between the iceblocks, and all intervals are carefully filled with sawdust. A roof of deals, placed on posts, will greatly facilitate the preservation of the ice. The foundation of the pile is a layer of the same material as the covering, 1 foot thick. The ice-pile is always opened at the top; and spaces caused by the removal of ice, or the sinking of the pile, must be carefully filled up. Experience has proved that the loss caused by melting, when the pile has been properly taken care of, does not amount to more than 25 per cent. per annum, and, very commonly, ice remains in the pile from one summer's end to the other.

The quantity of ice required at the milk-houses is calculated to be equal, in measurement, to the quantity of milk for the cooling of which it is intended; but with proper management two-thirds ought to be sufficient. At the churning-places the quantity of ice required varies according to local circumstances. At the central factory at Stockholm, for instance, during the summer of 1871,—June to September—1500 cwts. of ice were used in churning 180,000 "kannor" (= 103,680 imperial gallons) of cream, yielding 2500 cwts. of butter, all round numbers.

The ice intended for the cooling cisterns is chopped in pieces of about 3 to 4 inches square, whereby its cooling power is greatly increased.

The milk should be delivered as soon as possible after the milking is done, and carefully transported; and it has hitherto been considered advantageous to cool the milk during the process of milking and before being delivered. However, it has recently been stated that the more the original heat is retained, the more cream will the milk yield, as the cream begins to rise as soon as the milk begins to get cold, and the straining and transportation of the cool milk causes a very injurious interruption in the rising of the cream, which consequently will be imperfect. This seems very probable, but can only be proved by careful experiments. It is, however, a fact that the shorter distance the milk is transported the more cream does it yield; other circumstances, as quality, treatment, &c., being the same.

As soon as the milk is strained into the pails, they are placed

in the ice-water cisterns, at a distance of about 3 inches from each other. Experiments have been made to ascertain the proper height of the ice-water, but have not led to any positive results. It may, however, be stated that, during the summer season, and when the temperature of the milk-room is comparatively high, the surface of the milk should be on a level with the surface of the water, the upper layer of cream being thus kept as cool as possible; whereas during the winter season, or when the temperature in the cooling-room is low, the surface of the milk should be a few inches above that of the water.

The temperature of the cooling-room ought to be kept as low as possible during the summer season; but, if possible, never below 50° Fahr. during the winter.

The time required for the cream to rise depends principally upon how soon the milk is cooled, but also upon the temperature of the milk when being skimmed, as well as upon that of the ice-water and of the room. If a milkpail, say of 6 kannor, be placed in the ice-water cistern immediately after the milking, and the temperature of the water does not exceed 35° Fahr., the milk may usually be skimmed after a lapse of 10 or 12 hours; but it is better and safer to permit the milk to stand from 18 to 24 hours. At this low temperature the cream rises very suddenly, but is at first very thin, and requires a longer time to become firm. At farms from which the cream is sold to butter factories, it may, therefore, be profitable to sell only the upper and thicker cream, and to churn at home the lower and thinner, thus saving a certain quantity of buttermilk.

The cream which is not sent to the butter factory immediately after being skimmed off, ought to be put into the ice-water bath without delay. It ought not to be kept more than two days during the warmer season, and three days during the winter, before being churned, as it otherwise will become bitter, or acquire a bad taste easily detected in the butter. It may be considered as a fact, that *the fresher and absolutely sweeter the cream is, the better will the butter be.*

As above stated, no smaller quantity of cream than 10 kannor (= 5.76 imperial gallons) is received at the churning-houses of the dairy companies, the principal reason being that, as the cream is paid for according to the quantity of butter it has yielded, each delivery of cream must be separately churned, and that consequently smaller quantities of cream cannot be received without causing too much trouble; besides, it very often happens that larger quantities of cream yield comparatively more butter than when only a few gallons have been churned, although in both cases suitably-sized churns have been used.

The cream obtained from milk cooled by ice-water is, as

above stated, thin, and generally not as settled as that which rises from milk set in bowls or flat vessels, and kept in a comparatively warm room; and as a smaller quantity of butter is obtained from thin cream than from thick, the opinion is often expressed that the first-named method leaves a less satisfactory result than the latter. It will easily be understood, however, that this is not the case, if the merit of one or the other method is estimated by the quantity of butter obtained from a certain quantity of *milk* instead of *cream*. Nevertheless, it is true that the thin cream obtained by the ice-method will give more butter-milk, as well as somewhat less skimmed milk, than that obtained by the well-water method, the cream-setting in both cases being equally as perfect; but the loss, in itself insignificant, is more than covered by the finer quality of the butter, the better skim-milk, and the smaller expense for vessels and buildings required for the keeping of the milk during cream-setting, besides the other advantages of the ice-water method.

On an average, during 1871, at the central factory, 4.60 kanner (= 2.65 imperial gallons) milk have yielded 0.76 kanner (= 0.44 imperial gallon) cream, from which has been obtained 1 Swed. pound (= 0.93 Eng. lb.) butter; consequently 6 gallons of milk would yield, at this rate, 1 gallon of cream, although it must be observed that the milk has often been skimmed after standing only 12 hours. At the same place, milk purchased from neighbouring well-managed dairy farms, has required the cream of 5 kanner (= 31.5 lbs.) milk to produce 1 lb. of butter; whereas the cream churned on the farms has only required 4.25 to 4.80 kanner, or 26.7 to 30.2 lbs. of milk per lb. of butter obtained. The transport of the pure milk, for however short a distance, always causes a smaller yield of cream and butter.

Through the influence of the dairy-schools, organized by the Government, material improvements in cheese-making have lately been introduced, so that the present product is universally acknowledged to be of a superior quality; and hitherto there has been no lack of home demand. An over-production of this article, and more especially of skim-cheese, will undoubtedly take place, considering the progressive development in the breeding of cattle, and particularly in the products of the dairy, which is now taking place in Sweden. The Government has, therefore, sent out able persons to investigate, and to introduce, such modes of proceeding as may facilitate the sale of skim-cheese, even in foreign countries.

A more profitable manner of utilizing skim-milk than the manufacture of cheese is the rearing and fattening of calves. Numerous trials made during the past year, and particularly in fattening, have given very satisfactory results. The calves have

at first received some gallons of new milk, and afterwards as much skim-milk as they would take, until about two months old, when they have been sold at a price equal to about 3*d.* per lb. live-weight, or a little less than calves fattened with new milk. The skim-milk has thus realized 2·3*d.* to 3·5*d.* per gallon, in some cases 4*d.* per gallon. It has been remarked, that the colour of the veal has been somewhat darker than that of calves fattened with new milk; but this is pretty well prevented by giving the calves new milk for two weeks immediately before slaughtering them. Even if the veal of calves fattened with skimmed milk is inferior to that of new-milk calves, both to appearance and taste, the former mode of fattening them is, at all events, much less expensive than the latter, and leaves a more profitable return. In breeding cattle for dairy purposes, the above-named inconveniences are of no consequence; and many farmers, even in the vicinity of Stockholm, where cattle-rearing formerly did not pay, have adopted this cheaper way. Another reason is, that higher prices are now obtained for cattle, partly in consequence of the increased export to foreign countries of late years, and partly owing to the larger return from the cattle, since the butter-factory companies have rendered it possible for the farmer to produce and sell, advantageously, milk in any quantities.

Yet another way of utilizing some part of the skim-milk more favourably than by cheese-making is to give the servants who are entitled to new milk, twice, or even three times the amount of skimmed milk. This exchange is as profitable to the farmer as to the servants, as the former retains the more valuable cream and the latter receives a larger quantity of a nourishing drink.

The price paid for new milk by the purchasers who have delivered cream to the Company, has varied between 3·9*d.* to 4·3*d.* per gallon during the summer half-year, and 4·3*d.* to 5*d.* per gallon during winter, according to local circumstances. 4·3*d.* may be considered as the average price at which the milk has been delivered at the place of production, or at stations situated not far from it. Where the cream has been delivered direct to the butter factories, the price which the milk has brought has depended upon the price paid by the companies for the cream (according to the quantity of butter it has yielded), and the way in which the skim-milk has been utilized, varying between 4·6*d.* and 6·9*d.* per gallon.

*The purchase and working of the Cream.*—When the Mälär-Lake Butter factory Company began its operations, Oct. 1st, 1870, it took charge of a butter factory which had been in existence for some time. The intention of the Company was to establish butter factories in the provinces situated round Lake “Mälaren”

(hence its name); and this has been realised during the past year, in the cities of Nyköping, Eskilstuna, Orelero, Westeras, and Noertelge. Each of these branch factories is managed by a skilful person, enjoying the confidence of the neighbouring farmers. This man has a salary of 5*l.* 10*s.* sterling per month, and 20 per cent. of the net profits of the factory.

In consequence of the great advantages which farmers, located in the vicinity of the churning-places of the Mälars Company, derived from their operation, applications have been made from nearly all parts of the country, desiring the Company to extend its operations, and establish churning-places in other districts. The difficulty of satisfactorily controlling a large number of these places, scattered at large distances from each other, made the Company hesitate to comply with these requests, further than offering to advance the necessary funds, either to private persons of good standing, or to associations specially formed for the purpose, who would be willing to establish factories upon the principles of the Company. They also engaged competent persons to establish the factories, and qualified ones to manage the manufacturing, as well as dairy-maids, and they provide vessels and other necessary implements. The Company also sell the manufacture, charging a commission of 3 per cent. on the butter produced. Sixteen such agreements have already been made.

The success of the Mälars-Lake Company has also caused the establishment of several competing companies for the same purpose, of which seven have up to this date commenced operations. They have hitherto manufactured only small quantities of butter, but if they are well managed, they will gain the confidence of the public, and be able to extend their operations.

*Butter-making.*—A temperature of the cream of 57·2° to 60·8° Fahr. has been found the most suitable for making butter, but it depends somewhat upon the quality of the cream, the nature of the season and the temperature of the air, &c., &c. The churns which are most adapted for working by steam or water power, consist of a barrel, somewhat conical at the top, resting on a frame, and vertically movable on trunnions. In this barrel a churnstaff, provided with two wings, rotates at a speed of 120 to 180 revolutions per minute, depending upon the size of the churn, which generally contains from 17 to 60 gallons, and on the quantity of cream to be churned. The butter is obtained in about forty-five minutes. It is separated from the buttermilk by means of a strain, then placed in a tub of tin, and carried to the next room, where it is further prepared. The butter obtained from each separate quantity of cream is then worked by hand in a beechwood trough of oval form, in order to separate the buttermilk. It is then tasted by the managing

dairy-maid, and classified according to its taste and other qualities in three classes, and afterwards weighed, the weight and quality being noted in the factory journal. Before churning the cream,

*Figs. 2 and 3.—Swedish Factory-Churn and Working Apparatus.*

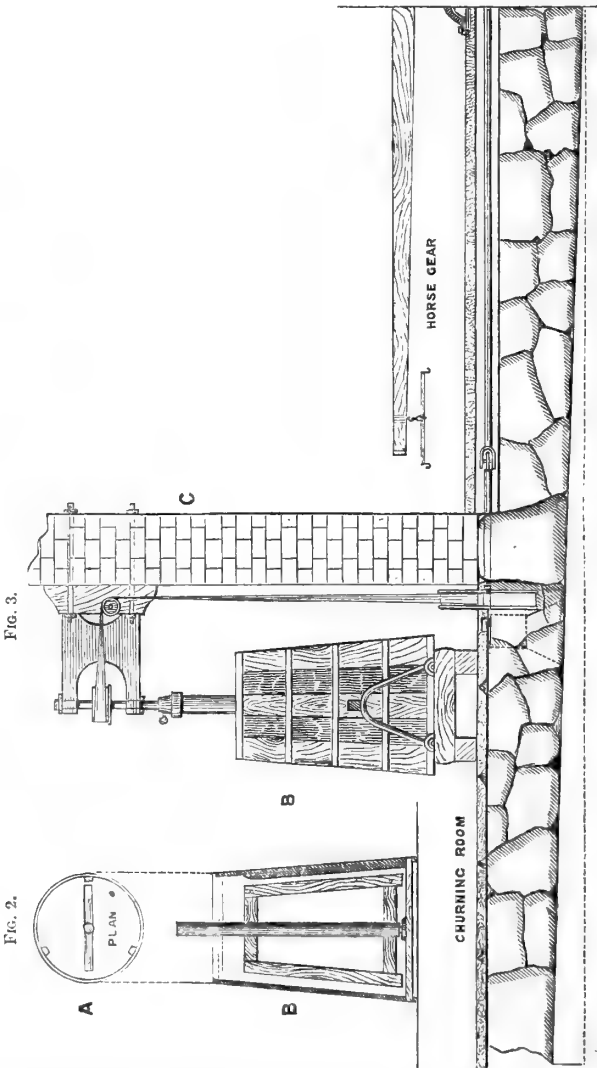

Fig. 3.—View of Churn (B) and working apparatus.  
C. Brick wall of the Churning-room.

Fig. 2.—A. Plan of Churn.  
B. Vertical section.

fluid annatto is added,—that from Messrs. N. N. Blumensaat, in Odense, Denmark, has been found the best,—in quantities suitable to the different seasons, giving the butter the colour which is required for different markets.

The assorted lumps of butter are separately and carefully worked together, during which operation a certain quantity of salt, varying from 2 to 5 per cent. is added. The salt used is refined in Sweden, and is as pure and dry as possible;  $\frac{1}{4}$  to  $\frac{1}{2}$  per cent. of sugar is also added. When the butter is ready, it ought to possess a waxy firmness, perfectly uniform in appearance. It is then packed in casks of beechwood, previously well saturated with brine, and containing from 60 lbs. to 100 lbs. of butter each. Before closing the casks, the name of the dairy where it has been manufactured is pressed in the butter, and finally the butter is covered by a piece of gauze, and thereupon a little salt. The mark of the Company and the nett weight, in English pounds, are painted on the cover, if the butter is of the first quality. The casks containing second-class butter are only marked with the initials of the dairy; and third-class butter is sold on the spot, or returned to the respective deliverers of the cream. The butter is sent at least once a week to the market it is intended for. During last summer butter was placed for some time in a dry and cool cellar, to ascertain how long it would keep, and after two months it brought the same price in London as fresh butter sent at the same time.

For the Russian market, as well as for some home demand, what is called Parisian butter has been manufactured. Perfectly sweet cream, which is heated to from  $80^{\circ}$  to  $90^{\circ}$  Cent. ( $176^{\circ}$  to  $194^{\circ}$  Fahr.) and then permitted to cool again to the usual temperature before being churned, is used for this kind of butter, which is otherwise made in the usual manner, but without adding annatto or salt. By the heating of the cream the butter obtains a slight almond-taste, and seems also to keep longer.

The cream is paid for according to the weight of butter it yields after the first working, and before the lumps are mixed together and salted, after a deduction of 3 per cent. for the loss caused by the final process and the adding of salt; but the experience gained last year proved that this loss did not exceed 2 per cent.

There is still a large field for similar operations in our extensive country, and the immense increase in the productions of the dairy-farm, the consequence of the development of this hitherto neglected branch of husbandry, is at the same time the foundation of the future advancement of our agriculture.

---

---

XIV. *Report on the Farm-Prize Competition of 1872.* By THOMAS BOWSTEAD, Eden Hall, Penrith.

DESPITE the progress made in agriculture during the last thirty years, and notwithstanding the many facilities and inducements still offered for the improvement of land, there may yet be seen in nearly every district of the United Kingdom hundreds of acres failing to yield their fair share of produce, while the stock they carry are deficient in numbers and economical qualities. No greater stimulus can well be given to the better management of land in any locality than is likely to arise from the seizing and describing the best specimens of farming, as is now being done through the agency of the Royal Agricultural Society. This system of farm-competition was first started in connection with the Oxford Meeting of 1870, and having then, as also last year, proved eminently successful, it commended itself to the favourable notice of Sir Watkin W. Wynn, Bart., M.P., the Society's popular and well-chosen President for 1872. Accordingly, that staunch agriculturist—for Sir Watkin is alike notable as the thorough farmer and the keen and fearless sportsman—wishing, no doubt, to signalise his year of office in some substantial and befitting manner, offered a silver cup of 100*l.* value, for the best-managed farm in South Wales and Monmouthshire, the Society contributing a second prize of 50*l.*

The conditions of the competition were the following :

1. That the farms are not less than 100 acres in extent.
2. That not less than one-fourth of the land (exclusive of sheepwalk) is under tillage.
3. That they are held by tenant-farmers paying a *bonâ-fide* rent for not less than three-fourths of the land in their occupation, or by landowners occupying their own farms, the total extent of whose property in agricultural land (exclusive of sheepwalk), does not exceed 200 acres, and whose sole business is farming.

Looking at the great breadth of country to which the competition was open, and the value of the prizes offered, the number of entries (only 19), struck the Judges as being remarkably small. And while amongst these were found some very fine farms, and a few excellent farmers, we regret to have to state that not a few of the entries were *totally unfit* for an inspection of this kind. Far be it from us to undervalue the frugality, industry, and sterling honesty plainly practised by some of the less eligible of the competitors ; but surely, lands dirty, imperfectly tilled, and out of condition ; fences crooked, broken down, and three times too



wide; ditches and watercourses entirely neglected; gateways without gates; buildings low, dark, dilapidated, badly ventilated, and inadequate to the requirements of the farm; live-stock ill-bred, ill-fed, and ill-looking; farmyard untidy and almost impassable; surely these are not the marks of prize-farming! And yet we feel bound to state that these shortcomings prevailed to a considerable extent on some of the farms. Perfection in every instance was by no means looked for; but we did expect that farms held by men of some mark,—men recognised in their several neighbourhoods as *pioneers* in agriculture,—would, making all due allowance for the unfavourable season, have been found at least *moderately* clean. In this hope, however, we were in more than one instance grievously disappointed.

Let it not be supposed, however, that our list contained all, or even a large proportion of, the farms in the district fit for exhibition. Far from it; and it is to be regretted that some of the holdings passed through in our journeyings, bearing as they did the strongest evidence of enterprise, capital, and liberal treatment, and having earned, as we were informed, no small local reputation, had not been included in the entry-list. Had we been permitted to view a larger number of first-class farms, and, therefore, we may suppose, had seen a greater variety of farming, more information would have been gained, and fresh facts would have been brought out, thereby rendering this report more acceptable to the reader.

The inspection of the competing farms has in former years been confined to the months of May and July, but, as the sufficiency of this plan had been questioned, and certain discussions on the subject had taken place in the Council, Mr. Jenkins, Secretary of the Society, desired my colleagues (Mr. Thomas Jenkins, of Plas-y-ward, near Ruthin, and Mr. Finlay Dun, of Weston Park, near Shipston-on-Stour) and myself to meet him, early in the month of January, and confer as to the best seasons in which to visit the several holdings. At liberty to make as many surveys of the farms as we might deem necessary, and the choice of time being also left with us, we agreed that a winter inspection was not only desirable but of the utmost importance. Besides the field operations which, in a favourable season and in moderately dry situations, may be looked for in January and February, an inspection at this season enabled the Judges to see something of the house-feeding of the cattle and the winter management of the sheep-stock. Moreover, the instructions placed in our hands would seem to require that if the farms were at all worthy of a minute inspection, they should be examined at two or more seasons of the year, as diverse as

circumstances would permit. The instructions were that we should especially consider

1. General management with a view to profit.
2. Productiveness of crops.
3. Goodness and suitability of live-stock.
4. Management of grass land.
5. State of gates, fences, roads, and general neatness.

Thus admonished, we began our first survey on the 30th of January, finishing it on the 7th of February; while our second inspection lasted from the 12th to the 20th of June.

After the hints already given, little surprise will be felt when it is stated that our first examination enabled us to weed out seven of the nineteen competing farms as not worthy of further consideration. Below, we give the names of the remaining twelve, the better management of which justified the Judges in paying them a second visit. We also add the names of the several proprietors and tenants, together with the acreage of each farm, and nature of the soil as stated in the entry-lists.

Name of Tenant.	Name and Situation of Farm.	No. of Acres.	Nature of Soil.	Proprietors.
James Culverwell.	Penrhos Farm, Abergavenny.	307	Rather heavy.	W. B. Johnson, Esq.
John Jones.	Panty-goetre, Abergavenny.	200	Light.	A. D. Berrington, Esq.
Daniel Owen.	Ash Hall, Cowbridge.	105	Light.	Representatives of the Rev. T. Gronow self.
Valentine Parsons.	Slough Farm, Chepstow.	291	Light.	Rev. E. F. Lewis.
Wm. Savours Powell.	Eglwynnyd, Aberavon.	419	Light and heavy.	C. R. M. Talbot, M.I.
Henry Price.	Undy, Magor, Chepstow.	107	Light.	James Pride, Esq.
John Pybus.	Court Farm, Magor, Chepstow.	278	Light and heavy.	Rt. Hon. Lord Tredegar.
Wm. Benjamin Roberts.	Lovestone, Pembroke.	430	Heavy and medium.	Earl Cawdor.
Michael Spencer.	West Aberthaw, Cowbridge.	183	Light.	W. C. Rayer, Esq.
John Thomas.	Eastfield House, Cowbridge.	158	Heavy.	Earl of Dunraven: trustees of late Col. Bennett and J. Richard Homfray, Esq.
Rees Thomas.	Saint Athan, Cowbridge.	195	Heavy.	Rev. Hanmer Morgan and W. C. Rayer, Esq.
James Till.	Caerwent, Chepstow.	482	Chiefly light.	Rev. E. F. Lewis.

AWARD OF PRIZES AND COMMENDATIONS.

*First Prize* to Mr. William Savours Powell, Eglwysnuny, near Taibach, Glamorganshire.

*Second Prize* to Mr. Valentine Parsons, Slough Farm, Caerwent, Monmouthshire.

*Highly Commended* for clean and in other respects creditable farming:—

Mr. Daniel Owen, Ash Hall, Cowbridge;

Mr. Michael Spencer, West Aberthaw, Cowbridge,

Mr. Rees Thomas, Saint Athan, Cowbridge.

*Commended* for certain special features in their management:—

Mr. James Culverwell, Penrhos, near Abergavenny, Glamorganshire, for varied improvements effected, during an eight years' tenancy, by the removal of dead and useless fences, and the levelling of unsightly banks and ditches; also for the erection, partly at his own cost, of well-arranged additional buildings, and for his fine flock of Cotswold sheep.

Mr. John Jones, of Panty-goetre, near Abergavenny, for his judicious selection and careful management of a very superior lot of grazing beasts, bought to fatten on deep, rich land.

Mr. William Benjamin Roberts, of Lovestone, near Pembroke, for his very creditable herd of Pembrokeshire cattle, and his excellent flock of Cotswold and Leicester sheep.

FIRST PRIZE FARM.

“Eglwysnuny” is situated about four miles east of the town of Aberavon, and is intersected by the road leading from Port Talbot to Bridgend. The farm comprises 419 acres, of which 141 acres are arable, and 278 acres meadow and permanent pasture; the latter including about 40 acres of rough cattle-ground, apparently reclaimed from the sea. The arable land is moderately light and easily tilled, but the grass land is of a colder and stiffer nature. This farm has been held by the same family since the year 1827, the present tenant, Mr. William Savours Powell, having succeeded his father four years ago as a yearly tenant. Much of the subsoil being clay and rather impervious gravel, a considerable portion of the farm has been under-drained. This operation was carried out by the late Mr. Powell, who, having pipes found by his landlord, did the cutting and carting of material at his own cost. Most of the fields are of large size, and suited to the acreage of the farm, one or two small enclosures being conveniently placed near the homestead. The greater part of the farm has a south-westerly aspect, sloping gently towards the Bristol Channel, from

which Eglwysnunydd is only two miles distant. Strong winds often prevail from this quarter, doing considerable damage to the ripe grain and newly-thinned turnips, and also seriously checking the growth of herbage, especially in the early spring.

Mr. Powell has no written agreement as to rotation of crops, neither is he tied down by any strict verbal injunctions. He could, like some of the hill-farmers, take any number of white crops in succession, and might, so long as he kept up the manurial condition of the land, sell off a portion of hay and straw; but he has never taken advantage of this privilege.

*Horses.*—Besides a hackney, eight farm-horses are kept, and these of a very superior description, combining activity, symmetry, and power. Except when working the two-furrow plough, they are always yoked abreast in pairs. They are stabled in winter, each man feeding his own team. Their food is generally hay in the racks, with a liberal allowance of whole oats, mixed with chaff. In summer, if grass be plentiful, and the weather tempting, they are turned out day and night; if otherwise, they have green food in the stalls. Mr. Powell aims at breeding a couple of colts a year, but, from some cause or another, the mares often prove barren. When fortunate, however, in this respect, the young colts come in for work at three years of age, older horses being sold off to make room for them. Close proximity to large collieries and iron-works creates a brisk demand for good and well-seasoned cart-horses, and high prices are realised, from 50*l.* to 60*l.* being no uncommon figure for sound animals, when five or six years old.

*Cattle.*—After trying successively the Glamorganshire breed of cattle, then Shorthorns, and finally, about twenty years ago, the Herefords, the late Mr. Powell came to the conclusion that the "white faces" were best suited to the land and climate with which he had to deal. In the summer months, Shorthorns flourished almost as much as he could wish, but in the winter season the Herefords had a decided advantage. The breeding of Herefords has proved a great success, and there is at present on this farm a wonderfully grand herd, of pure blood, fine massive form, and faultless touch, and generally numbering from 100 to 120 head. The cattle-stock at Eglwysnunydd are so much superior to any we saw elsewhere that we may well give a description of their management.

Mr. Powell has as many of his cows as is possible dropping their calves during the autumn and beginning of winter. These calves are nursed by the mothers during the first four or five months, a method which gives them a start they never forget. Moreover, it is found by experience that losses occur much less frequently where the calves are treated in this their natural way than when hand-fed from their birth; and if, as is Mr. Powell's custom, they are never allowed to lose their calves' flesh, fully

six months' keep is saved in a two or two-and-a-half years old beast. As long as the suckling continues the cows are kept in large open yards, having one or two covered sheds in each. The calves are confined, to the number of five or six in a lot, in comfortable boxes partitioned off in these sheds, are let to the cows twice a day, remain with them fully an hour, and, as soon as they are able to eat such food, are allowed a supply of the best hay, pulped roots, and a small quantity of meal composed of two parts of ground oats and one of peas. The cows during the whole of this time are fed upon straw, rough hay, and mangolds or turnips sliced, and, when seen last February, were in fine condition; in fact, they were nearly fat. When weaned, usually in April, the calves have an increased allowance of meal until about the middle of May, when they are turned out to grass. After being separated from their offspring the cows are tied in stalls, and milked for butter and cheese; in summer they are grazed in the fields day and night. The young heifers are expected to calve in May; the calves follow them in the pastures until November, when they are housed for the winter, and are fed for the most part on pulp and hay. At this time, also, the yearlings are brought in, are divided into two lots, and placed in the loose yards, the older lot getting sliced turnips twice a day, and oat straw; the younger division pulp and rough hay. In May they are again all sent to grass, the steers and less shapely of the heifers being stall-fed for the butcher the following winter. The feeding beasts have swedes or mangolds three times a day, meal twice, and hay three times, the last foddering of hay being given at 8 o'clock at night. The meal consists of "Tinworks bran" (or sharps), two parts; peas, or decorticated

\* This fattening substance, so highly praised by Mr. Powell, struck us as possessing some peculiar merits, and as being deserving of further notice. We therefore applied to Dr. Voelcker, who had, we were aware, examined a sample, and he most kindly furnished us with the following analysis:—

Moisture .. .. .	4·380
Oil and fatty matters .. .. .	23·960
Albuminous, or flesh-forming compounds .. .. .	4·750
Starch, digestible and woody fibre.. .. .	60·670
Mineral matters (ash) .. .. .	6·240

100·000

Containing Nitrogen .. .. \*760

Dr. Voelcker further says:—"Tinworks bran, or Tinworks sharps, is a refuse from tin-plate works; bran and sharps, together with palm oil, being employed in the polishing of tin-plates. This refuse is largely impregnated with palm oil, and possesses high fattening properties. It contains a great deal of ready-made fat, twice as much fatty matter, in fact, as the best oilcake. When free from copper and lead, it is in no way injurious to health; but, being deficient in the materials which build up the muscles or lean flesh, it is better adapted for fattening stock than for young and growing animals. When given to these last, therefore, it should only be administered in moderate quantities, and along with a due admixture of peas, beans, or other nitrogenous food."

cotton-cake, one part; and barley or oat meal, two parts. The daily allowance at first is two pounds each, and this is gradually increased to six pounds. At our winter inspection Mr. Powell showed us a row of sixteen splendid fat beasts, weighing from 18 to 22 stones (of 14 lbs.) per quarter; six of the same lot had been sold out at Christmas, at an average of 43*l.* 3*s.* a head, and the remainder were only waiting a favourable turn in the market.

The breeding heifers are put to the bull in July and August, at from 21 to 27 months old, according to size and forwardness, and are then distinguished by numbers burned on the horn. During the following winter they are fed upon straw and a few roots, with the occasional indulgence of a little rough hay the two months preceding calving. The main difficulty with these, however, as with the rest of the cattle, is to prevent their getting *too* fat. Possessing, as they do, such a propensity to lay on flesh, it need not be wondered at that Mr. Powell never sells off any cattle until they are fit and old enough to slaughter. Bulls for use at Eglwysnunydd have for some years been purchased from Lord Bateman, Mr. John Hewer, Mr. Green, Mr. Duckham, and other eminent Hereford breeders. By this means, and by a judicious selection of the home-bred heifers, Mr. Powell's herd has earned for itself a name, and his young bulls are eagerly sought after by other large breeders, one very promising yearling having recently been sold for exportation to Australia. To meet this demand five or six of the best-bred bull-calves are reared each year, and these, with a little indulgence beyond that given to the heifers and steers, make, when fit for work, 30*l.* to 40*l.* each.

*Sheep.*—Mr. Powell showed us a lot of 150 breeding ewes, chiefly Oxford Downs, very good, and full of wool. Until ten years ago Cotswolds were tried, but owing to the moist climate they did not give satisfaction. The sheep management may thus be briefly described:—

About the 29th of September the ewes are properly sorted, the oldest, and those known by the shepherd to possess any particular fault, being drawn out for fattening purposes. They are then divided into three or four lots, and placed on rich forcing food for a month, a ram, selected to suit the wool and other peculiar features of the ewes given him, being put with each lot. Superior male animals, as required to change the blood, are purchased at Gloucester fair. At the end of about six weeks the rams are taken out, and the ewes run on the grass until December, hay being allowed as soon as they will begin to eat it, and continued throughout the winter. They are then, if the fields are conveniently situated, allowed to feed for a few

hours each day on a piece of swedes or common turnips; or, failing this, they have a load or so daily given them on the pasture. The lambs are dropped early in March, the crop commonly averaging four lambs to three ewes. At about a month old the ram lambs (with the exception of a few reserved for breeding purposes) are castrated, and the whole are weaned early in July. They are not shorn, but are twice dipped, and sometimes powdered also, during the summer and autumn, and are run on the clovers and seeds until September. They are then placed upon white turnips, which they eat uncut, and are given a liberal allowance of hay, a few older sheep being mixed with them until they get accustomed to their new food. In December, or sooner if the supply of common turnips has run out, the wether lambs are separated from the ewe lambs, and the whole are put upon cut swedes. In January the wethers begin to have about a  $\frac{1}{4}$  lb. of a mixture composed of equal parts of decorticated cotton cake and Indian corn, and, in March, this is increased to  $\frac{1}{2}$  lb. The same mode of treatment goes on until the swedes are all consumed, usually towards the middle of April, when the wethers are shorn and sent to market. This year the average weight of the one-year-old wethers was about 21 lbs. per quarter, and they were delivered by instalments to suit the convenience of the purchaser. The draft ewes and shearlings are treated in much the same manner as the wether tegs, the main difference being their having, in addition to the cotton-cake and Indian corn, half a pound each daily of "Tinworks bran." If prices are good, and the supply of roots limited, these are sold off in the wool about the middle or end of March. Not requiring to be made fit for market, the ewe-tegs are fed, after their separation from the wethers, on cut roots and hay, no cake or corn being allowed. When the swedes have all been consumed they are hurdled on the two-year-old seeds, and are shorn about the middle of May. Mr. Powell, like most of his neighbours, is much troubled with foot-rot in his flock. As a remedy he uses sulphate of copper and alum mixed with common lard. Fluke-worm, or liver-rot, also prevails to some extent, and doubtless these two diseases may be attributed to the low and damp situation of much of the grass land.

*Figs.*—Three breeding sows of a large white breed are kept, but they call for no lengthened remarks. Their produce, with the exception of those required for home feeding and recruiting the breeding stock, are sold off, at 8 or 9 weeks old, and generally bring from 20s. to 26s. each.

*Rotation of Crops.*—Mr. Powell for the most part adopts the five-course system of cropping, namely—1. Roots; 2. Wheat or Barley; 3. Seeds; 4. Grass; 5. Oats. When this rule is

departed from it is mainly to leave the land a year or two longer in grass; for here, as in most situations, the land is apt to become clover-sick, and an extension of the course of cropping lessens this tendency.

*Roots.*—There is no material difference in the preparation of the land for mangolds, swedes, and common white turnips. In the autumn, as soon as may be convenient after harvest, the stubbles are scarified or broad-shared, twice if necessary, well harrowed, and, there being seldom anything to gather off, left flat until November. As great a breadth of the mangold ground as there is manure for is then covered with farmyard dung, and ploughed about five inches deep. In March it is harrowed, cross-ploughed, harrowed again, rolled, and left for sowing. About the middle of April, if the weather permit, the land is set up in drills 26 to 27 inches apart, the portion left short in autumn being manured now, in the drills, at the rate of about 30 tons of good rotten dung to the acre, and the whole receives, besides, a dressing of 4 cwts. of dissolved bones or mangold manure per acre, sown by broadcast drill after the manure is spread. The drills are then split up, and sown two at a time. Mr. Powell prefers a mixture of the long mammoth red mangold and the yellow globe (4 lbs. of the seed of the former to 2 lbs. of the latter per acre) as being convenient in storing, the long roots forming the walls of the store-heap, while the round bulbs fill up the centre. At our visit, on the 14th of June, 8 acres of mangolds were looking extremely promising, and were being stitch-harrowed, 2 rows at a time, by a very neat and easily-worked implement, made by Smith, of Kettering. The plants were being well hoed, and singled to a distance of 13 or 14 in., at a cost of 7s. per acre, a second operation being usually done for another 4s. The weight expected per acre is 40 tons. The crop is stored at the end of October or beginning of November, the fangs and roots being left on, and the top not too closely cut. They are pulled and laid in rows of four drills each for 5s. per acre, and are never allowed to remain uncovered over night.

The land for swedes is treated in much the same way as that for mangolds. 15 to 20 tons of dung are applied per acre (in the drills preferred), and 4 to 5 cwts. of artificial manures sown broadcast. The kinds most in favour are Sutton's Champion and Wheeler's Imperial, sown about the second week in May. The weight generally grown per acre is 20 to 25 tons, or in a very favourable season 30 tons per acre. These are all pulled in November, one-third or one-half, according to the condition of the land, being carted home for the use of the cattle-stock, while the remainder are pitted in the field, in heaps of half a cartload each, and covered with three inches of soil.



Besides swedes, Mr. Powell sows a few acres of early white turnips for the use of the lambs from September until nearly Christmas. Being all consumed on the ground, there is less need for applying farmyard dung, from 6 to 7 cwts. of artificial manure generally bringing an abundant crop. Besides stubble turnips, which succeed well here when the autumn is moderately favourable, care is taken always to put in from 15 to 20 acres of other catch crops. The dwarf white pea, sown in March, after oats, will, with the aid of 3 to 4 cwts. of dissolved bones, yield 45 to 50 bushels per acre. This is followed by white mustard, put in during July, and on which the sheep are generally penned in September or October. It is often convenient to grow a piece of common turnips alongside the mustard, and a strip of each, with the addition of hay twice a day, forms a very excellent run for the lambs. A still better plan is to have, as this year, a 2-acre plot of potatoes between the mustard and the turnips, as, by folding the sheep across the whole three, the food is kept clean, and the potato ground enriched by the sheep-droppings.

*Wheat.*—Wheat or barley (according to the nature of the soil, and the kind of crop taken off the same ground in the previous course) is planted after roots, the mangold ground being cross-ploughed in November, and the turnip ground stirred, to prevent loss of fertilizing matter, as soon as the sheep have cleared a few acres. With favourable weather wheat sowing begins the first week in February, and can, without risk to the crop, be continued until March. The seed is dressed with sulphate of copper (1 lb. to 5 imperial bushels) and drilled, 8 rows at a time, and 7 in. apart, at the rate of  $2\frac{1}{2}$  imperial bushels to the acre. In April, or as soon as the young corn is able to bear it, all the wheat crop is well harrowed and heavily rolled, but does not require hoeing. The kinds commonly grown are the Chiddam, Nursery, Hallett's, and Biddell's imperial, and the yield per acre is about 32 bushels.

*Barley.*—Barley, being apt to lodge, requires to be sown early. The first planted receives  $2\frac{1}{2}$  bushels per acre, while later in the season this is increased to 3 bushels. Hallett's Chevalier is the favourite sort, and the produce of an acre is usually 40 bushels. Like the wheat and oats, barley is drilled 7 inches between the rows.

*Seeds.*—Clover and grass seeds are sown by broadcast drill on the barley and wheat after roots, and covered by the chain harrow and roller. The mixture commonly used on an acre of land is as follows:—4 lbs. Cowgrass, 4 lbs. Red Clover, 2 lbs. Alsike Clover, 1 peck Ryegrass (Pacey's), with the addition, if the field be intended to lie down two or three years, of 2 lbs. to 3 lbs. of white clover. The greater part of the seed-shift is

top-dressed during the winter with lime and earth compost, each acre receiving about 15 loads, which may be taken to represent one ton of lime. About one-half the crop is mown for hay, dried in the usual manner, and at the end of 7 or 8 days carted into stack. The fog, or aftergrass, affords a rich pasture for the lambs in August, and the ewes tup well upon it in September and October.

*Oats.*—After remaining down in grass one, two, or more years, the clover-leas are for the most part ploughed for oats. This is done in December or January with Hornsby's 2-furrow-plough; the land is harrowed in March, and drilled with 3 bushels per acre, lengthwise the ploughing. Black Tartar oats succeed remarkably well, the yield seldom being under 50 bushels per acre. This year, however, we were shown a crop which cannot fall far short of, if it does not actually reach, 70 bushels per acre.

The present aspect of the Labour question, and the inducements now offered for sheep-breeding, have induced Mr. Powell, and many others besides him, to leave their arable land longer in grass, if not to lay away altogether such fields as may be adapted for sheep-pasture. At Eglwysnuny, a 20-acre field, well watered, drained, and fenced, and lying furthest from the homestead, is intended to remain down as long as it will graze to advantage. The seeds, sown three years ago, were only those used in alternate husbandry, but, having taken remarkably well, and a copious dressing of lime and rich old earth having been applied during the first year, there is every prospect of a good sward forming. Adjoining this field is another of 30 acres, a rather thin, weak gravel, put down, in 1868, with permanent grass seeds (from Messrs. Sutton and Messrs. Wheeler), at a cost of 32s. per acre, 2 lbs. per acre of alsike clover being added to the mixture. This field, being at the extreme boundary of the farm, and watered at the lowest point by a copious spring, was laid away many years ago, but having, by degrees, become foul, benty, and unproductive, leave was obtained to plough it up, and put it through a course of cropping; the conditions being that it should be cleaned, manured, and laid down again, entirely at the expense of the tenant. This addition to his acreage of grass land, though it may not be permanent, has enabled Mr. Powell meanwhile to increase the number of his flock very considerably (and we all recognise, though we cannot estimate, the benefits conferred upon light soils by the "golden hoof" of the sheep), while at the same time it has lessened the labour bills. Moreover, as he depends very much for winter provender for his cattle-stock on the produce of nine acres of richly irrigated, and 40 acres of well-composted meadow ground, the slight

diminution of the corn crop is less felt than where little or no old land is available for mowing.

*Harvesting.*—All the grain crop is cut with a Hornsby's 2-horse reaper; 3 horses are, however, commonly yoked where the crop is heavy. The barley, as well as the wheat and oats, is tied, set up in stooks of 10 sheaves each, and left unhooded. When the season is a wet one, "handmows," that is small conical piles of 4 or 5 stooks each, are found highly advantageous. The newly-cut corn is gathered by men, women, and boys, employed by the day, and, when thoroughly dry, is carried to the stack on well-built harvest-waggons drawn by 2 horses each. The ricks are placed on vermin-proof stone and mortar stands, commonly round, and are covered with machine-made thatch; and what we saw still standing in February were a pattern of neatness. The grain is threshed out by one of Clayton and Shuttleworth's portable machines, fitted with all the latest improvements, the power being derived from one of their portable 8-horse engines, which is also made available for chaff-cutting, grinding, root pulping, &c.

*Labourers, Wages, Cottages, &c.*—Mr. Powell has a very intelligent and painstaking set of workpeople; and, as he pays them well, and deals generously, yet firmly, with them, he has no difficulty in getting supplied. He acts as his own bailiff; and this of itself fosters a kindly feeling between employer and employed. Below is given a list of the hands generally engaged on the farm, with the wages and perquisites of each.

Qualification.	Weekly Wages.	Perquisites.
	<i>s. d.</i>	
Head Ploughman.	14 0	Cottage and garden free.
Second Ploughman.	8 0	Board and lodgings free.
Ploughboy.	10 0	
Head Cattleman.	9 6	Board and lodgings free.
Assistant Cattleman.	8 0	Ditto ditto.
Shepherd.	13 0	Dinner on Sundays: cottage for 1s. per week.
Boy.	7 0	
Labourer.	12 0	Cottage and garden free.
2 Labourers (each).	13 0	
3 Women (each).	6 0	

Having three cottages attached to the farm, Mr. Powell is, in this respect, better provided for than the generality of Welsh farmers. The three men shown as having board and lodgings free live in the farmhouse. They are engaged by the year,

from the 1st of May, and are paid monthly; a month's wages being commonly left in the master's hands. The rest of the workmen are paid fortnightly, on Fridays, Saturday being market day at the adjacent towns of Aberavon and Taibach. Women show no unwillingness to perform the lighter kinds of barn and field work: on the contrary, they gladly walk long distances to and from the farm, though they expect to be employed throughout the year, without any lost time, at the wages quoted. No cider is made, but the entire staff of workpeople are allowed beer in harvest and a fortnight's victuals; the men boarded in the house having, throughout the year, the further indulgence of a pint of beer each with their Sunday's dinner.

*Buildings, Fences, Gates, Artificial Food and Manures.*—The tenant's residence at Eglwysnunydd, although somewhat old-fashioned, is tolerably good. Screened from the farm premises by means of trees and shrubs, it is, nevertheless, in close proximity to them. Possessing an agreeable aspect, tastefully laid-out flower-beds, well-kept greenhouse, productive kitchen-garden, and other pleasant surroundings, Mr. Powell's home is certainly one to be envied. The farm buildings, mostly of stone and slate, are somewhat scattered, but they are ample for the requirements of the farm, and in good repair. Excepting main walls and main timbers, Mr. Powell is expected to keep the dwelling house and buildings in good condition. Besides "tying up" for 49 animals, there are 6 excellent loose boxes, averaging 15 feet by 11 feet, and a like number of conveniently placed cattle-yards, with sheds attached. The farm-horse stable is fitted up in the style common in the north of England, while engine-shed, cart and waggon house, ample granary, implement and artificial-manure shed, complete a well-appointed farmstead.

The fences on this farm are, for the most part, kept low, and neatly trimmed. Some of the old wide banks have yet to be removed, and these are being reduced each year, the soil making excellent compost. Mr. Powell finds for himself wooden gates, which are of a very good pattern; they are coal-tarred or painted every season, and are by this means well preserved.

Including the market value of home-grown peas and corn, Mr. Powell expends, yearly, in extraneous feeding stuffs, about 250*l.* Linseed cake is preferred to cotton cake, but the latter is found to answer extremely well with sheep when consuming a large quantity of succulent food. It is often mixed with unground Indian corn, and with good results. About 100*l.* a year may be put down as the usual outlay for artificial manures, while 25*l.* is annually paid for well-burnt lime. Besides this last, Mr. Powell is about to try the merits of *gas-lime* mixed with his compost heaps.

One word, in conclusion, as to the tenant and his general management. Well-educated, shrewd, and warmly attached to his home and his home duties; passionately fond, and an excellent judge, of live stock of all kinds; aided, moreover, by considerable knowledge of chemistry and other kindred subjects, Mr. Powell exactly comes up to our notions of a tenant-farmer of the first class. Undoubtedly the cattle stock are his strong point, but the sheep, too, are well cared for and profitable; the meadow and grass land is well looked after, the whole farm, most of which is on the coal-measures, and by no means rich by nature, is in high condition, and scrupulously clean; the general management is most orderly and systematic; a correct account is kept of all sales and purchases; and it is, therefore, with unqualified pleasure and satisfaction, that we awarded to Mr. William Savours Powell the magnificent cup so handsomely offered by Sir Watkin W. Wynn.

#### THE SECOND PRIZE FARM.

The "Slough" Farm, occupied during the last twelve years by Mr. Valentine Parsons, lies on both sides of the road leading from Newport to Chepstow, the homestead standing close by the highway, about  $4\frac{1}{2}$  miles from the last-named town, and a quarter of a mile from the village of Caerwent. The surface soil is generally a light loam, but, as it rests on a subsoil of clay and closely-knit gravel, much of the farm has required to be tile-drained. This improvement was effected, about 16 years ago, through the instrumentality of the West of England Draining Company;  $6\frac{1}{2}$  per cent. being charged on the outlay until paid off, and the tenant keeping the drains in thorough repair. The tenancy is a yearly one, dating from Candlemas, and is simply verbal. Unlimited leave is given for the sale of hay and straw, so long as the landlord or his agent is satisfied that a corresponding amount of manurial matter, in the shape of town-made muck, bones, and other auxiliary fertilisers, is brought back to the farm. Mr. Parsons is at this time getting from 3*l.* 10*s.* to 4*l.* per ton for wheat straw; the purchaser takes delivery from the rick, and doubtless these prices, on a farm somewhat deficient in buildings, justify the tenant in selling off large quantities of this material. Little or no hay is now sold off.

Including about 50 acres of glebe lands, rented by the landlord, and sublet to Mr. Parsons, the Slough Farm contains close on 292 acres; of this 201 are under the plough, and the remaining 91 acres are made up of rough cattle ground, dry meadow, orchard, and 35 acres recently laid down to grass. This last comprises some of the thinnest and poorest of the land met with on the farm, and, having only been down six years,

may be said to be in a state of transition. The seeds, though they were selected with great care, have, we suspect, been faulty, and it is now found necessary to top-dress this portion of the farm by consuming roots upon it with sheep during the winter and spring. In this way, too, the dry meadows are from time to time enriched, and made to bear the frequent mowings to which they are subjected.

*Horses.*—The farm is worked by six useful horses, yoked abreast. Excepting during the summer, when, if grass be plentiful, they are turned out, they are kept in a large open yard, provided with a shed along one side. Into this, however, they are simply turned at night, and allowed uncut hay, being taken into the stable morning and evening to receive the bulk of their food. A liberal allowance of bran, pea-meal, pulp, and oats, mixed with chaff, keeps them in condition during the busy season, and with this treatment Mr. Parsons seldom has a horse off work. No colts being bred, the stables are replenished by the purchase, now and again, of a young improving animal to supply the place of the aged and worn out.

*Cattle.*—Very useful Shorthorns are kept at Slough, but they are by no means a numerous lot. Butter and cheese being made for sale, milking properties are more valued than pedigree or faultless form. Eight, and sometimes nine, cows or heifers are annually sent to a neighbour's well-bred bull, and the produce reared, and, with the exception of one or two kept to fill up the cow stock, all fattened off at a trifle under three years old. The calves are mostly dropped in March, are suckled for the first 6 or 8 weeks, and then have milk from the pail, half new and half skimmed. By degrees they are reduced to the poorer description only, and, when this in its turn falls off, the calves are put in loose yards, and fed on cut mangolds, clover, vetches, and linseed cake, or crushed corn, until the close of summer. In the fall of the year the corn or linseed cake is discontinued, and a liberal supply of swedes and hay given through the winter and spring. In the summer the young stock are grazed on the rough meadows; the older division, now turned 2 years of age, and therefore preparing for the butcher, having, commonly, 2 lbs. of cotton cake, and 1 lb. of linseed cake per head daily. The fattening process, however, is seldom completed until the winter, when for this purpose the heifers are tied in stalls, and the steers are placed in a warm fold-yard. Their diet then consists of cut swedes (or mangolds in the spring) three times a day; 3 lbs. each of linseed (or cotton) cake and mixed meal (wheat, barley, and pea) once a day, given along with chopped clover. One feed daily of whole clover is also given. Last spring the best of eight fat beasts made,

when under 3 years old, 33*l.* 10*s.* The young stock, rising 2 years old, are all wintered in the fold-yards, and are fed on whole roots and barley straw up to February: afterwards a little rough hay, if it can be spared, is given in place of the straw. Oat straw, as used on the first-prize farm, would be useful at this time, but, from some cause, as yet unexplained, oats cannot be advantageously grown at Slough. Besides home-bred cattle Mr. Parsons purchases, every autumn, as many additional feeding and store beasts as he considers that he requires, and either fattens them, or sells them off in the spring to large graziers.

*Sheep.*—Sheep on this farm, besides being numerous, are a very superior lot, and the management of them is highly creditable. They are pure Cotswolds, and great care is exercised in selecting the ewe-stock, as also in the purchase of rams. The flocks of Messrs. Handy, Gillett, Hewer, and other famous breeders in Gloucestershire, furnish Mr. Parsons with rams of the right stamp, and the results justify the payment of high prices in order to secure a heavy fleece, aptitude to fatten, sound constitution, large size, light offal, and pure breed. Before going to ram, the youngest of the ewes, and the best of the theaves (shearlings), say 100 of the former and 60 of the latter, are put, for two or three weeks, upon the clover eddishes. About the 25th of September they are divided into three lots, and carefully sorted according to wool, size, and outline. A ram, suited to the ewes given him, or, we ought to say, calculated, by means of his good points, to correct any defects they exhibit, is then placed with each lot, and by this method the flock is maintained pure, and remarkably uniform. Of the 161 ewes kept for stores last autumn only 1 died during the whole winter, 3 were barren, and the remaining 157 had following them, on the 1st of May, 212 lambs. When 5 or 6 weeks old the ram lambs are castrated, the shepherd himself performing the operation, and generally without any loss. About the middle of June the whole are weaned, dipped, and run on the clovers, getting a little linseed cake, say  $\frac{1}{4}$  to  $\frac{1}{2}$  a lb. each daily, until they go to turnips. Immediately before corn harvest, the whole of the sheep, including both lambs and ewes, are dipped, and this for the most part puts them safely through the busy season, preventing the attacks of fly and destroying parasites. Between the 20th and the end of September the lambs are put upon common white, and afterwards upon yellow turnips, cut, with a liberal allowance of unchopped clover hay. When they have become accustomed to this change of food, 60 or 65 of the best ewe lambs are taken out for stock purposes, and are deprived of the cake diet, but are, in other respects, fed like their neigh-

hours. With the remainder the cake is continued, and an additional  $\frac{1}{2}$  pint of peas daily is given in spring to finish them off. The common turnips mainly last until the first week in December, and by this time the swedes have done growing, and are fit for use. About the middle of March, when the swede heaps begin to disappear rapidly, mangolds are called into requisition; but, until the sheep are used to them and the risk of scouring is abated, they are given mixed with about one-half or three-fourths of swedes. When the swede-land is wanted for barley sowing the fat sheep are removed to some snug, dry grass field, where the mangolds have been previously stored in a convenient corner, or waste place, adjacent to the land intended to be thus manured. By the end of April the wether tegs, and those of the ewe tegs not bred from, are usually in prime condition, and command a high figure. They are sold out of the wool, and generally throw 10 lbs. per fleece, though this year, owing to the entire flock being down with foot-and-mouth disease, the produce was not over 9 lbs. The carcase weight usually reached is 20 to 21 lbs. per quarter, the average price this year, for the entire lot of 120 tegs, being 3*l.* a head. The draft ewes make heavy weights by about February, and are sold off in the wool, making this year 4*l.* each. Besides home-bred stock, Mr. Parsons purchases annually about 50 additional sheep, which are commonly fattened along with the draft ewes, and sold off at the same time.

The breeding ewes, when separated from the rams, again form one lot, and are run on the pastures, a small allowance of hay and roots being given when the winter sets in, and the growing fœtus demands an increased supply of nutriment. A few weeks before lambing they are folded on common turnips, or swedes, which they eat uncut, and from which they are not removed until the lambs begin to make their appearance. Though strongly opposed to anything like pampering of his ewes during pregnancy, Mr. Parsons deems it of the utmost importance that they should not suffer any material check, but should rather be kept uniformly well, and in progressive health, during a period of such great importance. The young ewes, if they seem to require it, are separated from the older portion of the flock, and indulged a little more than the ewes of mature age.

*Pigs.*—Pigs on this farm call for no special notice. One, and sometimes two, breeding sows (Berkshires) are kept, and their produce, excepting only the three or four required for home feeding, are sold off immediately they leave the wheat stubbles.

*Rotation of Crops.*—Here, as in most farms throughout this district, the system of cropping is the 4-course, namely, 1. Roots; 2. Barley or Wheat; 3. Seeds; 4. Wheat.

*Roots.*—The preparation of the land for roots begins with a



very light ploughing, followed by scarifying and harrowing, immediately after harvest. Should any couch appear, which is seldom the case, it is picked off, and the land then left quiet a few weeks to grow out the annual weeds. In November, or before Christmas, if possible, a deep ploughing (of 10 inches) is given where the land will bear it, and the ground left in furrow during the remainder of the winter. In March, if the season admits of it, the fallow-land is well harrowed, scarified, harrowed again, hand-picked, if necessary, and left for sowing.

Mangolds are not sown in large quantity, from four to five acres, when a good crop, generally meeting the spring demands of the cattle and sheep. Yellow Globe, sown on 25-inch drills, and singled out 15 inches apart, are found to answer best. Besides artificial manures, a copious dressing of farmyard-dung is usually given. This year, however, owing to the heavy and incessant rains, the yard-manure could not be got on the land; but, the plot being already in good heart, it is expected that the heavy dose of mangold-manure (11 cwts. per acre) will produce an abundant crop. The first hoeing and thinning costs 6s. per acre, while the second going through, usually done by the same persons, requires a further sum of 3s. 6d. The produce of an acre is seldom under 35 tons, and the crop is stored at the end of October. The mangolds are first trimmed, as they stand, with a reaping-hook; they are then pulled, the soil shaken off, but no roots removed, and afterwards carted. The heaps, which are made in the meadows, orchard, rick-yard, or poorer grass fields, according to circumstances, are covered, first with a layer of straw, then with a few inches of soil, and, lastly, with a neat coating of thatch; and in this way the bulbs are preserved fresh and juicy until after midsummer. The mangold-ground, we must not omit to mention, is compensated for the removal of the entire crop by bringing back on to it, for consumption by cake-eating sheep, a goodly quantity of swedes.

Swedes are mostly sown towards the end of May, or early in June, on 24 to 26-inch drills, and thinned to a distance of 13 or 14 inches. From 16 to 18 single-horse cart-loads of dung are spread (at a cost of 2s. 6d. an acre) in the rows, and 5 to 6 cwts. of dissolved bones and mineral superphosphate (two-thirds of the former and one of the latter) are sown broadcast over it. Skirving's Purple-top variety is found to be the best, and from 3 to 3½ lbs. of seed per acre insure a good plant. Growing, as they do here, until the end of November, swedes are seldom drawn off before December. They are then all pulled and cleaned, at a cost of 8s. 6d. per acre, one-third being either taken home for the use of the cattle, or pitted in grass fields, or on the mangold-ground for consumption by sheep. That

portion of the crop left on the swede-land is, for convenience in penning the sheep, thrown into heaps of about two cart-loads each, and protected from frosts by a covering of soil. Twenty-five to twenty-eight tons of swedes per acre is considered a good crop, thirty tons being sometimes produced.

Common turnips, to the extent of ten or twelve acres, are grown for the maintenance of the lambs from about September 20th until the beginning of December, a few being, if possible, spared for the ewes. They are always eaten where they grow, and are, therefore, raised solely from artificial manures—such as dissolved bones (5 or 6 cwts.), nitrate of soda (1 to  $1\frac{1}{4}$  cwt.), and other portable fertilizers. White turnips, when late planted, are often sown on the flat; in fact, wherever swedes or common turnips are grown on thin, poor soil, Mr. Parsons prefers to plant on the flat, the ridge being always adopted on the deeper soils, and where there is less cause to fear the effects of a dry season.

*Barley.*—This cereal, to the almost total exclusion of the others, is planted after roots. Seeding begins early in March, as much of the land as can be got ready being sown by the end of the month. Three bushels per acre, vitrioled as wheat, and, when dry, mixed with about 4 lbs. of Italian rye-grass, is drilled  $6\frac{1}{2}$  to 7 inches between the rows. Mr. Parsons has tried, and with good results, the plan of drilling barley twice over on the same land, lengthwise and then across, but without materially increasing the quantity of seed. By thus spreading the barley closely over the entire surface of the ground, a heavier and more uniform crop is thought to be secured. The kind of barley in most favour is Hallett's pedigree, and, in a tolerable season, the yield per acre is 45 to 50 bushels.

*Seeds.*—Italian rye-grass, we have already said, is drilled along with the barley, Pacey's, or other English varieties, being seldom grown. The clover mixture, say 8 lbs. of red, 4 of white, 4 of trefoil, and 2 of alsike, is sown, by broadcast-machine, harrowed and rolled. Portions of the farm having become clover-sick, Mr. Parsons is this year trying the effects of giant sainfoin, 3 bushels to an acre, in place of the red and white clovers. Of the seed-shift two-thirds are commonly mown, with Wood's machine, and made into hay, stacked, and given mainly to the horses and sheep in winter and spring. Odd as it may appear, the wheat-crop is *always* stronger and better where the seeds are mown than where depastured, and more especially so if the clover be luxuriant.\* This corroborates our own notions on the subject, namely, that no kind of plant-food is so beneficial to the wheat-crop as

---

\* See Dr. Voelcker's paper on this subject, 'Journal of the Royal Agricultural Society,' 2nd series, vol. iv. No. 8, p. 397.—EDIT.

the roots of clover, especially when it is, by being left for hay, allowed time to send its roots deep into the earth, and bring up a supply of rich and easily appropriated nourishment.

*Wheat.*—This is a staple product of Slough farm, and the crops seen by the Judges on the 19th of June were very promising. Though occasionally grown after roots, and sown, as this year, even as late as May 1st, Mr. Parsons greatly prefers lea-wheat. Standing well in moist seasons, and producing a vast amount of straw, as well as grain, the Browick Red is his favourite sort. Preparation of the land for wheat may thus be briefly described. Where not manured for the previous root-crop, the clover-lea is covered, immediately the harvest is over, with 14 to 16 tons per acre of good dung, which is spread, and ploughed in about  $4\frac{1}{2}$  inches deep. Then, if the weather be dry, it is heavily pressed with a smooth roller; for, without a thorough and complete firming of the land, nothing but disappointment would follow. After this process of consolidation is finished, the harrow is applied, and the seed, having been first dressed with sulphate of copper, is drilled, 8 inches apart, at the rate of from 2 to  $2\frac{1}{2}$  bushels per acre, towards the end of October. To those occupying poor land, insufficiently manured, this may appear a light seeding, but it is ample on land well farmed, and the quantity is gradually increased as the season advances. Sowing of autumn wheat is generally concluded by the second week in November, and the ordinary yield is from 40 to 45 bushels per acre. Mr. Parsons intends to try the plan of giving the dressing of farmyard-manure to his young seeds, instead of applying it the following year to the wheat, believing that, besides greatly increasing the clover-crop, he will also secure a heavier yield of grain, though, perhaps, less straw, than by the method hitherto usually adopted.

*Catch-crops*, though at one time extensively cultivated, have now been almost entirely given up, Mr. Parsons having satisfied himself that, where an attempt is made to grow rye, vetches, trifolium, peas, &c., after the wheat, the succeeding root-crop is seriously diminished in bulk.

*Beans.*—Beans are sometimes planted to a limited extent on the stiffer portions of the farm, but there is nothing specially noteworthy in their management.

*Harvesting.*—At a cost of from 9s. to 10s. per acre, additional hands undertake to cut (with reaping-hooks), bind, and stook, the whole of the wheat-crop, while the ordinary staff of workmen mow the barley with common scythes for 2s. 6d. per acre. This last is not tied in sheaves; after remaining in swathes two or three days it is turned, and, by the end of a week, can, if well-ripened, be safely carted to stack, loose, three rows being first gathered together for convenience in loading. The custom is

to build the large barley-ricks in an oblong shape, while the wheat-stacks are round, and often contain 40 to 45 quarters each. The shepherd, knowing well the importance of harvest time, leaves his sheep that he may come and build the ricks; and those seen by the Judges in February certainly did him credit. The thatching, too, though by whom done they did not inquire, was also the perfection of neatness.

Except for contract work, no extra wages are given in corn harvest. On carting days, however, both men, women, and boys are given dinner, and, if kept late in the evening, are allowed bread and cheese, or some such refreshment, at 6 P.M.

*Threshing.*—Threshing of the grain at Slough is done by one or other of the itinerant firms who make it their business to travel through the country with a complete steam apparatus for the purpose. The general charge is 3*d.* per bushel for wheat or barley, which covers the tying of the straw, sacking, and wheeling the grain into barn or granary. No beer or cider is included in the contract, but, if the work be efficiently and quickly performed, a moderate quantity of “drink” is generally given over.

*Labour.*—Extra hands, we have already said, are engaged in corn-harvest. The following, however, is a list of the staff of labourers generally employed by Mr. Parsons, who, we may add,

	Weekly Wages.	Perquisites.
	£ s. d.	
Shepherd.	0 13 0	Cottage and garden, 20 perches of potato ground prepared and manured, 30 <i>s.</i> extra for lambing time, and 30 <i>s.</i> for rick building.
Carter.	0 11 0	Cottage and garden, 20 perches potatoes manured, raised, and sent home; half a fat pig, breakfast on Sundays, and dinner when from home with his team.
Ploughman.	0 11 0	20 <i>s.</i> extra from May to September.
Ditto.	0 11 0	Ditto ditto ditto
Cattleman.	0 12 0	30 <i>s.</i> extra on 1st of May; 20 perches potato ground prepared and manured; breakfast on Sundays.
Labourer.	0 11 0	Task work allowed when possible, and cottage at 3 <i>l.</i> a year.
Ditto.	0 11 0	Ditto ditto ditto
Boy.	0 5 6	
Ditto.	0 4 6	
Ditto.	0 2 6	
	4 12 6	

has advanced the terms to his men about a shilling per week since the beginning of the year.

In addition to these prices two quarts per day of cider, or beer, is allowed throughout the year to each man, and half that quantity to the older boys. In hay and corn-harvest the above quantities are considerably increased; the common plan being to give beer in the forenoon, and cider, which is considered stronger, in the afternoon. In task-work, too—such as mowing, turnip-hoeing, &c.—a certain allowance of “drink” per acre is served out as the work proceeds.

*Artificial Food and Manures.*—The amount annually expended in extraneous manures and feeding stuffs on this farm is by no means extravagant; a more liberal outlay, especially in concentrated food, might, we consider, be advantageously adopted. Last year only three tons of cake were purchased, and this, with the value of home-grown grain consumed, amounted to 127*l.* 1*s.* 9*d.* Artificial manure, consisting of variously styled bone-manures, prepared by the leading firms, cost, in 1871, 137*l.* 2*s.* 6*d.*

*Buildings, Fences, Gates.*—A somewhat old-fashioned, yet comfortable and conveniently placed dwelling-house, built of the limestone furnished by the district, answers well every requirement of the tenant. Out-buildings, except barn-room, which is very ample, are, as we previously hinted, somewhat deficient. Built of stone, and mostly slated or tiled, what there are seem well fitted up and healthy. If asked for, more would at once be built by the landlord; but, with such a highly remunerative price as is obtainable for straw, Mr. Parsons is indifferent in the matter.

Fences are mostly well-kept and orderly. They are commonly slashed twice during the year; the first trimming, usually given during June, costing 10*d.*, and the second, generally in September, 8*d.* per 20 perches (6 yards to the perch). Cutting, laying, and casting an old fence costs about 6*d.* per perch.

Gates, made of wood, are in good condition. They are supplied by the landlord, and kept in repair and painted by the tenant, who also finds wooden posts.

In concluding our description of the second-prize farm, we would observe that, while Mr. Parsons does not profess to be a model farmer, he is most methodical and painstaking in everything he does. By dint only of the closest industry, economical management, and assiduous attention to every detail of his farming operations, is he enabled both to pay a large rent and to live comfortably. His sheep-stock are both numerous and excellent, while his cattle are quite an average of the district. His grass-land is fairly managed; his corn crops are clean and uniformly good; his fallow-land well tilled, and, considering the

season, very free from couch and other noxious weeds; whilst his farm accounts (which we look upon as a most important feature) are well kept and easily understood.

Mr. Parsons has previously taken six prizes for the best-cultivated farm in the Union of Chepstow; and fifteen other minor trophies grace his well-spread sideboard.

#### MR. DANIEL OWEN'S FARM.

Mr. Daniel Owen took Ash Hall, with the farm of 83 acres, at Candlemas, 1866. With this he works 22 acres of his own land. Three miles from Cowbridge, and about ten from the sea-coast, Ash Hall commands a beautiful and extensive view: 300 feet above the sea-level, and with a considerable sprinkling of timber, the clouds gathered from the Atlantic deposit their watery burthen somewhat freely, and gave a rainfall of 40.96 inches for 1871. Mr. Owen, in December, 1860, purchased 23 acres of unenclosed mountain-land half a mile from Ash Hall, at 24*l.* per acre; had a small house and premises built, made roads, and planted for shelter and ornament 18,000 trees, mostly of the pine tribe. The same spirit of improvement has since been continuously exhibited at Ash Hall, which was taken on a ten years' lease. Roads have been made, fences renewed, land-fast stones removed, furze, fern, and weeds got rid of, 16*l.* per acre embarked as capital, manures and feeding-stuffs freely used, the produce in six years nearly trebled. But, masterly and full of instruction as is Mr. Owen's management, the Judges felt that Ash Hall could not fairly compete with ordinary rack-rented farms. With a handsome house, gardens, and shrubberies, entered on the rate-books at 50*l.* annual value; with 32 acres of pleasantly undulating park, divided by iron hurdles into convenient paddocks; with only 51 acres of arable land, until this spring 12 acres in addition were broken up from sainfoin; with a small herd of nice cattle, and an occasional flying sheep-stock, Ash Hall must be regarded as a "fancy" farm, which, although not eligible for money prizes, is well deserving of high commendation, and, from the spirit and success which has characterised its management, demands a somewhat detailed description.

Eight years' colonial experience has taught Mr. Owen to make the best of his surroundings; bread and meat, as he pertinently puts it, may be economically manufactured from road-scrapings: the wide deep banks which begirt his fields and roads are accordingly turned up and mixed with such yard-dung as can be spared,—with lime, of which 17,340 bushels have been used

from 1866 to 1872, or with salt, of which 200 tons have been applied within the same period. One characteristic feature of Mr. Owen's farming is his liberal use of common salt, of which he employs nearly 40 tons annually, supplying nearly every crop at the rate of about half a ton per acre. Delivered from Bromsgrove at Ystradowen station, half a mile from the farm, the salt costs from 14s. to 15s. per ton. Its liberal application is found to answer well, probably ensuring the solubility of the silica contained in the soil, and thus stiffening the straw of the grain-crops, and perhaps lessening the depredations of slugs, wire-worm, and other insect pests. Nor on the light gravel loam of Ash Hall has salt the disadvantage sometimes seen of running the soil together, and making it work up raw. Nitrate of soda, bones, and superphosphate, the portable manures in use, cost annually upwards of 40*l*. A like annual outlay is incurred for linseed and cotton-cake. Barley-meal and bran, with home-grown and purchased oats to the annual value of 100*l* are also consumed, raising greatly the manurial condition of the farm.

Like most observant agriculturists, Mr. Owen has discovered that grass-land is eminently grateful. His 32 acres of park have been greatly improved by liberal and reiterated dressings of soil, manure, lime, and salt; by consuming mangold, cake, and corn upon it with sheep; by treating considerable portions of it with liquid manure from the house and stables, which, instead of being applied, as now, tediously by cart, might readily enough be distributed by gravitation. The upper third of the park is grazed this season chiefly by four powerful, clean-legged cart-horses, prize-winners at local shows, and a pair of them entered for Cardiff. On the lower subdivisions at our June visit were five roomy, handsome, shorthorn cows, and five home-bred two-year-olds of the like good type, with eight feeding heifers, purchased at May-day for 15*l*. 10s., and intended to go out fat in September. Five level, smart, thriving calves, from the home-bred cows, by a well-descended, good-looking shorthorned sire, purchased in Gloucestershire, were, in June, getting skim-milk, cut mangold, and trifolium, with 1 lb. daily of linseed-cake, and were kept chiefly in the yards. 100 head of cattle have in six years been sold off, many of them bringing at Christmas 36*l*. each. Oats and oil-cake to the extent of 4 or 5 lbs. each are the chief auxiliary feeding-stuffs. Close by the roadside lies a field containing six acres of level meadow land, a telling example of the profit from a liberal outlay. As it could not be broken up and improved by a rotation, Mr. Owen drained it in 1867, applied 300 bushels per acre of lime, and in the subsequent season 20 loads per acre of farmyard-dung; while in the present spring he has dressed it with 1 cwt. per acre of nitrate of soda, 2 cwts. superphosphate,

and 3 cwts. of common salt. Judging from adjoining fields in their natural condition of unaided poverty, this six-acre piece certainly yields more than a double return, and will cut 50 cwts. of superior hay. This season's outlay, although slightly exceeding 30s. per acre, will, Mr. Owen believes, be repaid in the extra hay and aftermath; but, even without further fertilisers, the augmented yield will certainly extend over several years.

The friable gravel soil, usually six inches deep, and readily worked by a pair of good horses, reposes on the carboniferous limestone, which is here so full of faults that the horses at work often slip into holes several feet in depth. 24 to 30 bushels of oats, barley, or wheat, and half a ton of rough innutritive grass, was the annual yield of the poor moor-land when first it came into Mr. Owen's hands. It was almost hopeless to attempt swedes or mangold, and the weakly crops were overrun with weeds. The like wretched returns are still found throughout fields adjacent to those which have been so rapidly rendered productive and profitable. Secure of his ten years' possession, Mr. Owen at once began his spirited process of reclamation. The furze and fern were stocked and burned; the light soil with the porous limestone substratum stood in little need of draining; deep ploughing prepared the land usually for oats, which were helped along by salt, nitrate of soda, and similar adjuvants.

For mangolds and swedes, the stubbles, which are now very clean, are forked over in autumn and ploughed; a spring furrow usually follows; during March 10 cwts. of common salt per acre is broadcasted and harrowed in; and at seeding time they receive, in the drills, 25 to 30 tons per acre of farmyard-manure, which if applied in autumn might run too rapidly through the porous soil and subsoil. This year the acre allotted for mangold was in the first week in April seeded with 8 lbs. of Cornell's Orange Globe, drilled along with 6 cwts. of dissolved bones. Under this liberal management 50 tons per acre have not unfrequently been realised.

Swedes, of which 12 acres of Sutton's Champion were this year drilled during the last few days of May, are treated much in the same way as mangold, are easily kept clean by timely horse and hand-hoeing, and are expected to attain to 30 tons per acre. The roots are mostly fed off with sheep, of which about 160, usually good Cotswolds or Wiltshire Downs, are bought in August, fatted, and generally sold in March. As they are liberally treated with clover-hay, cake, and corn, with 2 ozs. daily of salt, the light land gains firmness and condition, and in the subsequent season 50 to 57 bushels of wheat are obtained. To the large number and liberal management of the sheep fed Mr. Owen in great part ascribes his successes.



Farming highly, Mr. Owen now finds that he can dispense with a regular rotation. Oats, although they have yielded 90 bushels per acre, do not pay so well as wheat, which is accordingly grown to the exclusion of the other cereals, and occupies this year 35 acres. Following after seeds, green crop, and sainfoin, white Essex wheat is deposited with the 10-furrow drill, 7 inches between the rows. The seed well vitrioled is subsequently dried by mixing with lime and salt, and  $2\frac{1}{2}$  bushels per acre are put in early in spring; this year on February the 9th and 10th. The spring-sown wheats are found to be less liable to blight and to lose plant, and are altogether more reliable than those sown in autumn. A month previous to drilling, 10 cwt. per acre of salt is distributed broadcast on the land intended for wheat; a top-dressing of 1 cwt. of nitrate of soda with 2 cwts. of salt is applied in April or early in May; hand-weeding is pursued when necessary. On the occasion of the visit of the Judges on June 17th, the wheat was remarkably clean, beautifully level, of a dark luxuriant hue, just coming into ear, and promising a return of 60 bushels per acre. It is unnecessary to advert to the money-value of such a crop; but the 35 cwts. of straw would evidently of itself fetch 5*l.*, and a good margin of profit would hence remain even after allowing 8*l.* per acre for rent, rates, labour, and manures.

The grass-seeds are deposited with a broadcast drill amongst the wheat, and usually consist of 16 lbs. per acre of mixed clovers, with a peck of Italian rye-grass. Generally they produce an aggregate yield of five tons per acre, and are cut twice. The third crop, usually estimated at  $1\frac{1}{2}$  ton, is folded over with sheep, getting cake and corn in the same way as when on roots. On 17th June, a crop standing 5 feet high, and yielding not less than three tons per acre, was being cut with scythes, at a cost of 7*s.* with two quarts of beer for each man daily. Six or seven acres of trifolium are annually grown on the wheat-stubbles, partly used green, and the remainder converted into hay. Common turnips follow, are got in towards the end of June, are forced with a good dose of artificial manure, and, fertilized by the frequent mists from the Bristol Channel, they produce sound and heavy crops.

Appreciating the advantage of having his workpeople handy, Mr. Owen has four cottages. Besides stabling in connection with the house, there are two small convenient sets of farm premises, each standing round three sides of a square, built of stone and slated, spouted, and the rain-water carefully stored for use in large wrought-iron tanks. Chaff-cutter, corn-crusher, root-pulper, and cake-bruiser are worked by horse-power; light waggons, some of Cowbridge manufacture, costing from 22*l.* to 26*l.*, are used for hay, harvest, and other work; for carriage of manure

and delivery of corn two-horse carts are employed. Howard's ploughs do their work in their usual good style. The Cambridge roller and Crosskill's clod-crusher are much prized for consolidating the wheat-land during spring, and limiting the damage done by wire-worm. Mr. Owen has not changed a farm-servant for six years; with a cottage and garden he gives 14s. per week, like other employers, his wages have since Christmas advanced about 1s. a week; drink is only supplied during hay time and harvest. Hoeing, mowing, reaping, and other such work, are done by the piece, and during harvest the men earn on an average from 20s. to 25s. per week.

#### MR. MICHAEL SPENCER'S FARM.

"West Aberthaw," situated in the parish of St. Athan, on the coast of Glamorganshire, about  $5\frac{1}{2}$  miles south of the town of Cowbridge, deserves notice mainly on account of its very clean and neat cultivation. In this respect, indeed, we doubt whether we saw any farm surpassing Mr. Spencer's.

Resting on the Lower Lias Shale and Limestone, the soil is a kind of light clay, and tolerably productive. Some 20 acres of the farm have been stone-drained, and the remainder is by nature dry enough for the generality of crops. The total quantity of land in hand is, in round numbers, 243 acres, of which 143 acres are arable, 40 old grass and meadow, and 60 acres rough and somewhat inferior cattle ground, which last was added to the farm only two years ago.

Mr. Spencer has never asked for a lease, but holds the farm by a written agreement, one clause in which prevents the taking two white crops in succession; a second debars the selling off any hay, straw, or roots; and a third, peculiar, but full of meaning, precludes the use of *lime, unmixed with soil or some other matter, to grass land*. Born where he now resides, Mr. Spencer has occupied the farm eleven years on his own account, and previous to that time he acted for five years as manager to his father.

The four-course system of cropping, more fully described in our account of the second-prize farm, is also strictly adhered to at West Aberthaw. At our June visit we found the farm under the following crops:—Lea wheat, 28 acres; spring wheat, with grass seeds, after roots, 17 acres; barley, with grass seeds, after roots, 23 acres; seeds, partly mown for hay, 36 acres; mangold-wurzel, swedes, white and yellow turnips, 36 acres.

The preparation of the land for root-crops begins with a light paving, as soon as possible after harvest, with Coleman's cultivator.

The parings are burned, and then a dressing of good dung, say 20 tons per acre, is spread and ploughed in. Left in rough furrow through winter, a spring ploughing or scarifying, and sundry turns with the harrow, fit the land for sowing. Yellow-globe mangolds are grown on 26-inch drills, and are usually singled to a distance of 14 or 15 inches. For mangolds and swedes alike, about 6 cwts. per acre of Lawes' bone-phosphate is given, besides the dressing of dung; and the result, in a good season, is from 35 to 40 tons of mangold, and 20 to 25 of swedes. Hoeing and thinning, first time over, cost 6s., with the addition of one quart of beer per acre. Covered with a thick layer of straw, and then thatched (no soil being used), Mr. Spencer's mangold heaps show both taste and careful foresight. Common turnips, drilled on the flat, after the catch-crops (trifolium, mustard, vetches, &c.) have been consumed by cake-eating sheep, are successfully grown. A dressing of 4 to 5 cwts. of bone-phosphate is applied to the white turnips, and the crop maintains the lamb stock during the beginning of winter, allowing a few for the ewes also in the early spring.

Barley or spring wheat, being found more remunerative than oats, always follows roots. Golden-melon barley, drilled at the end of March, at the rate of 3 bushels, commonly brings a yield of 50 bushels per acre. Of spring wheats Mr. Spencer prefers "Grace's White" variety:  $2\frac{1}{2}$  bushels per acre are drilled in February or beginning of March, and an average crop yields 40 bushels. "Taunton-dean," "Essex White," and other autumn wheats, are sown on the clover leas, from about the 20th of October until the second week in November, according to convenience and weather. No manure is applied at this time, and, when a good sample of seed can be procured, it is seldom vitrioled. The wheat is rarely cropped by sheep in spring. Grass seeds, along with the barley and wheat after roots, are sown in April. A common mixture is the following:—

- 4 lbs. Trefoil (*Medicago Lupulina*),
- 8 lbs. Red Clover and Cowgrass,
- 2 lbs. Dutch Clover,
- 2 lbs. Alsike ditto, and
- $\frac{1}{4}$  to  $\frac{1}{2}$  an imperial bushel of Italian Ryegrass.

This year, however, Mr. Spencer has put down 9 acres into sainfoin, sowing 3 bushels per acre, with 6 lbs. of the yellow and white clovers; while in another field, by way of experiment, and to seek out some remedy for clover-sickness, he has sown in place of the above dressing, for one year's grazing, 2 bushels of sainfoin, and 8 lbs. of mixed clover. About one-third of the seed-break is mown for hay, which is given to the farm horses during the busy months of spring.

The grain crops on this farm, we may here remark, are not horse or hand hoed, and hence the trim and clean condition of the land is the more creditable. No spasmodic efforts by way of preparation for this prize-competition, but long and close attention only, can have brought about this state of things.

Grain is all cut by a Hornsby's Reaper, which is hired at 2s. 6d. per acre for the use of the machine. Beer is allowed at this time, but not throughout the year. Corn is all tied and stoked; wheat is built in fine round ricks of 30 to 40 qrs. each; while barley is stacked in large mows, 5 yards in width by 16 yards in length. The grain is threshed out by an 8-horse power portable steam-engine and machine in which Mr. Spencer holds a share, and which is occasionally let out for hire. There is also on the premises a steam mill for crushing oats, maize, &c., for horses and pigs, the power from which is also made available for chaffing and pulping.

The farm at West Aberthaw is worked by six very useful horses, which are stabled in winter, and in summer are fed in fold-yards on trifolium and other green food. A couple of foals a year are commonly bred, and these run in the fields with their dams until weaning time.

Cattle are not bred to any great extent, the vacant stalls in autumn being filled by purchased beasts. Seven or eight good Hereford cows are sent to a neighbour's bull, and the produce reared, the best of the heifers replenishing the cow-stock, and the steers going off fat at about  $2\frac{1}{2}$  years old. Young cattle are wintered in loose yards, having cut straw and pulped roots. Fattening beasts receive cut roots, loose hay, and 4 lbs. each daily of linseed or cotton cake. From being more hardy, and therefore requiring less indulgence, Herefords are preferred to Shorthorns.

Mr. Spencer keeps, in a general way, 100 Cotswold ewes of more than average stamp, and a change of rams is purchased, every alternate year, at Cirencester ram fair. The lambs are shorn about the end of June, and, from their picking up much less mud in the wet season of winter and spring, great benefit is found to be derived from this plan. They are usually weaned on sainfoin, and sent to common turnips in October, with  $\frac{1}{2}$  lb. cotton-cake daily. Towards spring the allowance is increased to  $\frac{3}{4}$  lb., hay and corn, or peas, &c., being added, and the tegs are got off at 12 to 14 months old. Last June, 71 fine sheep, which we saw, were sold, out of the wool, at  $4\frac{1}{2}d.$  per lb. live weight, which the owner considered to equal 9d. per lb. for the carcase; but, if we were selling, we should much prefer the latter method of calculation; for, instead of 50 per cent., the saleable carcase of a recently-shorn sheep varies from 60 to 65 per cent. of the

live-weight, according to age and fatness. Mr. Spencer contemplates trying the effect of a cross between a few Oxford Down ewes and a Cotswold ram, believing that by so doing he will, without sacrificing size and quality, produce a heavier animal, and one that will winter better.

More attention is paid to pigs on this farm than on some others that we visited. Berkshires are found to answer best; and of these, partly for home use, but mostly for sale, 20 to 30 are bred annually.

No cottages are attached to Mr. Spencer's farm, but labourers' dwellings are obtainable in the adjacent village. A month's food in the corn-harvest, and 15s. per week all the year round, is the rate of wages given to good ploughmen and waggoners, ordinary labourers earning about 13s. Two young men, boarded and lodged in the house, are paid, respectively, 20*l.* and 15*l.* per annum. Extra hands are employed in the busy seasons, and a large amount of farm-work is done by contract; the total yearly sum paid for labour, not reckoning food and drink, being about 300*l.*

Of artificial feeding stuffs, Mr. Spencer purchases most extensively of cotton-cake, preferring it to linseed-cake, especially where succulent food accompanies it. Of the two kinds he usually gets through 8 to 10 tons annually, while artificial manures commonly cost 70*l.* to 80*l.*

Looking down upon the Bristol Channel, and, on a clear day, commanding a view of Somerset and Devon, the dwelling-house at West Aberthaw is agreeably and conveniently placed. The farm-buildings are chiefly of stone and slate; a good feeding byre, constructed more after the best English and Scotch fashion, having been recently added. The whole of the stading is kept in repair by the landlord, who also supplies good field-gates. The hedges, improved by timely dressings (costing 1*d.* per yard), are kept low and well-trimmed.

In ending our report of this farm we may add that the old grass and meadow is, equally with the ploughed land, remarkably clean and neatly kept. Occasional doses of dung and rich earth maintain its fertility, and hence, as we saw, young bullocks can be fattened in the pastures without the aid of corn or cake. Altogether, Mr. Spencer's farming has a great deal to recommend it, and might well have received at our hands a more lengthened description than our space permits.

#### MR. REES THOMAS'S FARM.

Adjacent to the farm last described, and belonging, in part, to the same proprietor, is the "Rock Farm," entered upon by

Mr. Rees Thomas four years ago. Resting on limestone, the soil is, in some places, not more than a few inches deep, and, therefore, soon shows the effects of dry weather; while in winter, owing to the clayey nature of the surface, the land is apt to get poached.

At our winter inspection portions of this farm were rather foul, but, by the time we paid our second visit, so great was the improvement in this and other respects that we considered Mr. Thomas worthy of a high commendation. The judicious winter-feeding of the cattle-stock, the superior management of a numerous flock of sheep, the liberal use of artificial food, and the successful growth of catch-crops, render Mr. Thomas's style of farming worthy of imitation in many ways. "Rock Farm" contains about 181 acres, namely, arable, 120; sheep walk, 20; sainfoin, 9; old meadow and pasture round the house, 32 acres. The system of cropping adopted is the four-course, namely, 1. Wheat; 2. Roots; 3. Wheat, Barley, or Oats; and 4. Seeds. This year the arable land is under the following crops, the unequal quantities arising from the irregular size of the fields:—

							Acres.
Wheat, after clover and roots	...	...	...	...	...	...	46
Roots	{	Mangolds ...	5	}	...	...	...
		Swedes ...	12	}	...	...	...
		Turnips and	17	}	...	...	...
		Potatoes,			...	...	...
Oats, 7	}	after roots	...	...	...	...	...
Barley, 9							16
Seeds		...	...	...	...	...	...
							120

Since last harvest, we may further note, the whole of the swede and turnip land had produced a heavy crop of trifolium, vetches, or Italian rye-grass, the only piece of idle-fallow being the 5 acres of mangold ground. Part of the trifolium, which was an excellent crop, had been cut green for the use of the horses, and the remainder, at our June inspection, was being mown for hay. The vetches, a most luxuriant plant, were being mown by the shepherd, and eaten through iron hurdles by 260 lambs and tugs; the hurdles being gradually drawn towards the uncut vetches as required by the shepherd's convenience. The older sheep were also receiving 1 lb. each, daily, of crushed oats, linseed and cotton cake, mixed, and, though they appeared to be suffering somewhat from the intense heat then prevailing, they were in fine condition. The Italian rye-grass was grazed

by ewes before and after lambing. As with Mr. Michael Spencer, so also with Mr. Thomas, a written yearly agreement prevents the sale of hay, straw, or roots, and the growing of two corn crops in succession, but when, as is commonly Mr. Thomas's plan, one or other of the above-named forage crops intervenes, this last-named restriction is very properly removed.

But to return to the course of cropping, of which a brief account only can be given, we will begin with wheat. The clover-leas, which are always sown with this cereal, are heavily dressed in September with farmyard-dung; this is spread, left 3 or 4 weeks, and then well chain-harrowed, and ploughed in. This method is found to admit of the furrows being more closely packed, and secures a firmer seed-bed than the plan generally practised. The autumn wheats ("Essex White" and "Short-eared Hoary"), at the rate of about  $2\frac{1}{2}$  bushels per acre, are drilled the first week in November. Particular attention being paid to the winnowing of this, and all seed corn, the use of vitriol is dispensed with. Wheat, to prevent its getting "knee bent," is commonly grazed by sheep in the early spring; occasionally, too, roots are carted on to it for the use of the sheep, thus insuring complete consolidation. An average crop of wheat on this farm throws 35 bushels, but we saw some this season which will yield 40 bushels, or upwards.

Immediately the harvest is over, preparation for the vetches, trifolium, and other catch-crops begin, and, as we have already said, Mr. Thomas grows them both extensively and well. However, as we purpose touching upon this branch of Welsh farming in our "general remarks," we need not here give details of their cultivation.

Mangold ground, as we have before said, is left idle through the winter. It is ploughed, harrowed, and, as far as possible, cleaned in the autumn, and receives, before Christmas, a plentiful dressing of dung. Further stirring of the soil takes place in March, and the mangolds are planted, on 2-foot drills, at the beginning of April. At the time of sowing, a dressing of 10 cwts. per acre of artificial manures (guano, superphosphate, blood manure, mangold manure, and nitrate of soda, in equal parts), and 3 cwts. common salt, is broadcasted on the dung. Home-grown seed is generally used, the plants are singled to a distance of 14 or 15 inches, and, from the above liberal dose of fertilizing matter, 40 to 45 tons per acre are expected.

Swedes, of which the earlier sown are planted on drills, and the later portion on the flat, 24 to 25 inches between the rows, are grown with 4 cwts. each of mineral superphosphate and dissolved bones per acre. They are usually put in from the end of May to the middle of June. Drawn off in November and

December, at a cost of 6s. per acre, the swede crop is partly pitted in the field, and partly carted to the buildings, for store cattle and fattening beasts. A few, when they can be spared, are eaten whole, in the spring, by the ewe-stock.

Besides the common turnips sown in June and July, on the flat, after catch crops, and manured with 6 cwts. per acre of superphosphate, a small plot of White Tankards is put in early (with dung and artificials, because mostly pulled off), for the use of the lambs in August and September. Instead of applying the entire dressing of artificial manures at the time of sowing his swedes and turnips, Mr. Thomas very often reserves about one-half, and sows it, by drill, after the plants have been singled. A slight scuffling saves the manure from waste, and, in moist weather especially, this plan is much approved.

The root-shift, as it becomes cleared, is at once prepared for wheat, barley, or oats, as the case may be, and the whole is seeded down. Spring wheat and Chevalier barley are drilled at the rate of 3 bushels per acre; the former in February, and the latter in March and April. A full crop of barley reaches 50 bushels. Oats are but sparingly grown, as they never attain a great bulk. Though occasionally taken after roots they more commonly follow some catch-crop, which, from having been seeded immediately the wheat crop came off, has been consumed by the middle of April.

Grass seeds, of which the following is the mixture generally adopted, are sown by seed-barrow (or broadcast drill), lightly harrowed, and rolled, about the second week in April:—

- 4 lbs. Red Clover,
- 4 lbs. Yellow Clover,
- 2 lbs. White Clover,
- 2 lbs. Alsike Clover,
- $\frac{1}{2}$  bushel Italian Rye-grass.

About one-third of the seed-break is mown for hay, dried and stacked in the usual way.

We have mentioned at the outset a piece of sainfoin on Mr. Thomas's farm. This, a 9-acre field, is one of the best crops of the kind we ever saw, and looked like yielding  $2\frac{1}{2}$  tons per acre of highly nutritious hay. When viewed on the 17th of June it was ready for cutting, and will form an excellent winter food for the sheep, this being the use to which it is almost entirely put. This sainfoin was sown along with a wheat-crop, and, though this is the fourth mowing, it does not appear to diminish in luxuriance or quality. The land, however, is richly manured by folding sheep upon the aftermath, and giving them liberally corn and cake.

Mr. Thomas finds six useful horses, yoked in pairs, abreast.



equal to the work of his farm. They are stabled all the year, and are kept on clover-hay, chopped straw, oats, pulped roots, &c., in winter; and on trifolium, vetches, and other green food, in summer. No horses being bred, young, improving colts are picked up, as opportunity offers, to supply the place of horses disposed of before they fall off in value.

No cattle are bred on this farm, the plan of buying a sufficient number of steers in the autumn, generally Herefords, two to three years old, being found more convenient, if not more profitable, than breeding. These beasts are placed in open yards, and fattened on pulped roots and chaff (given fresh), and 5 to 6 lbs. of cake, mixed, occasionally, with crushed corn. Last year's lot cost 15*l.* a head in, and went off in May and June at 28*l.* to 35*l.*, the markets, however, having meanwhile turned in favour of the seller.

Sheep are both numerous and well-cared for on the "Rock Farm," the cake and corn-troughs being never out of use. And, while the greater number thus kept show a fair return for the liberal feeding, it is only in this way that the manurial condition of the thin soils can be maintained. About 100 good Shropshire and Oxford Down ewes, bought annually at Wilton Fair, are put to well-bred Cotswold rams, purchased from Mr. Thomas's father. During winter these ewes run on the grass fields, meadows, and occasionally whole turnips, during the day, and are folded at night in a large, dry, open yard, troughed all round, and receive a feed of malt-dust (8*d.* per bushel) and chopped straw or hay, night and morning. This mixture struck us as being a very agreeable and healthy kind of food, and we were not surprised to find that the animals ate it with much zest. The crop of lambs from 100 ewes is rarely below 150, and of these a few of the oldest and best are occasionally sent to the butcher. The remainder are shorn and weaned in June, and fed on vetches, or on the seeds and pastures, with  $\frac{1}{2}$  lb. of cake a day, until September. Having been first taught to eat common turnips whole, spread on the pastures, they are next penned on them, and have the roots cut; sainfoin, or other hay, and chaff, being added to the allowance of cake. In December the swedes take the place of the common turnips, and thus, the supply of artificial food going on the while, the whole of the year-olds are generally got off, in the wool, before March expires. Last year's lot made 68*s.* a head. A "flying-stock" of sheep being kept on this farm, the ewes purchased annually are sold off fat the following autumn or winter, at great weights.

Pigs do not demand more than a passing remark. Two Berkshire sows are usually kept, and their offspring run on the stubbles and in the cattle-yards until their turn comes to be fed off as porkers.

Implements are numerous and good. Hornsby's grass-mower was seen doing efficient work, and a self-raking reaper from the same firm cut, in 1871, with a change of horses, 26 acres in one day. Cowbridge waggons are used for the conveyance of hay and corn. Barley is carried loose, and put in oblong stacks, while wheat is secured in well-built round ricks.

Threshing and finishing of the grain for market are effected by one of Hornsby's portable machines, and, when not in work at home, the apparatus is occasionally let out for hire. Chaffing, too, is done by steam-power. Saint Athan district has not escaped the recent rise in wages, which, between our two visits, may be taken at 1s. to 2s. per week. Waggoners, and the better class of labourers, receive 15s., and women 6s. per week; men lodged in the house, 18l. to 21l. a year. Total yearly amount paid for wages is about 180l. No cottages are included in the take of the farm, but Mr. Thomas is responsible for the rent of three, for which his men are charged 1s. 6d. per week. No drink is allowed except in hay and corn-harvest, when two quarts per man daily are served out. Extraneous feeding stuffs, of which linseed and cotton cake are the principal, cost, in 1871, 176l., while the artificial-manure bill was 97l.

Thatched, and, what is worse, small, uncomfortable, and out of repair, the dwelling-house at Rock wants "mending with a new one," for Mr. Thomas is a tenant worthy of every encouragement. The farm-premises, too, through belonging to two proprietors, are divided, and therefore inconvenient. Some very useful fold-yards, however, and ample barn-room, are on the place, and the whole are kept in repair by the landlord, who also finds wooden gates. The fences, maintainable by the tenant, are somewhat untidy, and not quite in show condition; but Mr. Thomas explains that this shortcoming, as well as the rather dirty state of portions of the land, arises, in some measure, from his having had the farm only four years in his occupation.

#### GENERAL REMARKS.

Having now given a very general description of the first and second prize farms, and having briefly noticed those highly commended by the Judges, it may not be out of place, taking the nineteen competing farms as a type of the agriculture of South Wales and Monmouthshire (and we feel we may not unfairly do this) to make a few general remarks touching the farmers and the farming brought under our notice.

The agriculture of Monmouthshire has long been admitted as well-nigh equal to that of the best cultivated districts in England and Scotland, a fact which, when we consider the many natural

advantages possessed by this favoured county, need cause no surprise. It was doubtless the hitherto recognised and much dreaded superiority of the once Welsh county that caused the competitors resident in Wales to think it "hard lines" that Monmouthshire should have been included in this exhibition of farms, when, at the same time, the three remaining English counties (Gloucester, Hereford, and Worcester) which, with South Wales, make up the Society's show district for this year, were, and in their opinion very properly, debarred from entering the lists. Results, however, show that there was no need for raising the objection, seeing that Glamorganshire, and not Monmouthshire, has produced the best managed farm. Doubtless, Welsh farming has within the last few years made amazing progress, and this improvement may be in a great measure attributed to the rapid extension and marked prosperity of the mining and manufacturing industries. Create the demand, and you are sure to increase the supply. In and around the busy thriving towns of Newport, Cardiff, Swansea, Neath, Aberdare, and Merthyr Tydvil, a hardworking and ever increasing population earn high wages, and therefore demand, as they deserve, good and abundant food. Beef and mutton command as high a figure here as in the largest and most flourishing of our English towns, while dairy produce is eagerly bought up. In fact, everything the farmer has to sell realises a highly remunerative price; and the resources of the land, if they are not already made the most of, must soon be called into the fullest action. Clover hay, for instance, meets with a brisk market at 4*l.* 10*s.* to 5*l.* 5*s.* per ton; whilst wheat straw, variously estimated as worth 14*s.* to 20*s.* per ton to tread into manure, can be readily sold at from 3*l.* 10*s.* to 4*l.* Without expense to the farmer these products are generally taken from the premises by the dealers' own carts, thus considerably enhancing the prices quoted. Many good managers, especially those scantily supplied with buildings, avail themselves of these prices, and sell off a large proportion of their straw and some hay; and, by bringing back all they can procure of town-made muck, and supplementing it with the best artificial fertilizers, they can easily maintain unimpaired the manurial condition of their farms.

A glance at the geological map shows that the farm-prize district rests on a great variety of formations, and therefore the soils met with differ correspondingly in character. In Monmouthshire, and the north-eastern portions of Glamorganshire, the Old Red Sandstone preponderates, and this always furnishes land capable of producing in abundance every kind of crop. Narrow strips of this rock are also found skirting the sea-coast in Carmarthenshire and Pembrokeshire, while the northern

divisions of these two counties seem to rest on various limestone deposits. The southern and western districts of Glamorganshire overlies the coal-measures; while some dry, fruitful, and easily cultivated soils are also furnished by the new red sandstone, red marl, and carboniferous limestone. None of these geological features, except perhaps the coal-measures, indicate very bad land; in fact, if we exclude a poor and exposed farm in Cardiganshire, we did not meet with any very poor soil under cultivation.

The nineteen farms we had the privilege of inspecting have a proportion of grass land varying from one-fourth to one-half, and sometimes even reaching two-thirds, of the entire holding. One competitor certainly said that he had not an acre of old grass land in hand; but this is quite an isolated case, most of the farmers being able to summer-graze, and to keep until fattened, all the cattle they breed.

Besides the permanent grass fields which commonly surround the homesteads, and which, from their very position, must of necessity be kept productive, and in clean condition, most of the farmers have in occupation considerable tracts of what they term rough "cattle ground," or marsh land, fringing the coast, and evidently reclaimed at some remote period from the Severn or the Bristol Channel. These pastures are frequently scattered, and at a considerable distance from the main farm; but they form an excellent run for the young cattle, the drier and better descriptions readily fattening bullocks and barren cows or heifers. Being, as may be inferred, on a low level, to attempt underground drainage would, in most cases, be a waste of money. The surplus water is therefore got rid of by means of open ditches, 15 to 20 or 25 yards apart, running into wide trenches or mains, these last being made to serve as divisions between the several enclosures. These damp pastures producing, as they do, an abundance of rather coarse herbage, doubtless answer well in dry seasons, such as we have experienced of late years; but in a wet summer the quality of the grass is seriously deteriorated. Moreover, the animals suffer alike from exposure to the keen cold winds of spring and autumn, and from the scorching heat of a July sun; and we would suggest the erection of cheap wooden sheds just above the flood-line. The most inferior of these marshes, however, are a valuable addition to any farm, though they might be, and in not a few cases have been, vastly improved by an occasional dressing of bone-dust, lime, or compost. When thus treated, they can be advantageously mown for hay; but, while the acreable yield may be heavy, the quality cannot compare with a crop containing the better class of rich meadow grasses.

The arable farming in Monmouthshire, and in the lower dis-

tracts of South Wales, is, upon the whole, creditable. Many of the newest and most approved implements have been introduced, and there is no lack of skill in using them. Drill husbandry is almost universal, and it is only on the very smallest holdings that grain is sown by hand. Horse and hand hoeing of the crops is, however, much too little practised, and mainly from neglect in this respect some of the farms have become provokingly foul. The plan of sending women or boys over the fallows in autumn, to fork up and carry off in baskets all the couch, docks, thistles, and other rubbish, though it may appear expensive at first, might be advantageously extended, and would secure an ultimate saving. We had hoped that the fine open country, and large square fields, frequent enough between Chepstow and Newport, might have furnished some examples of steam cultivation, but nowhere in our wanderings did we meet with an instance of this effectual, economical, and rapidly extending method of turning up the soil. To adopt this system single-handed requires, of course, a great amount of capital, and could only be made to pay on very large holdings; but the formation of steam cultivation companies, such as are now springing up in the great arable districts throughout England, would doubtless prove a profitable speculation. In Wales, miles of huge banks, from 6 to 10 feet wide, and topped, it may be, with a few briars and scattered quicks—intended as divisions between small and irregularly-shaped fields, but rather providing snug nurseries for all manner of filth—might well be dispensed with. If the steam-plough effected nothing more than the removal of these eyesores, much valuable space would be economised, the nation enriched, and the farms greatly beautified.

The rotation of crops most prevalent in the farm-prize district is the four-course, namely, roots, barley (or wheat), seeds, wheat. With some farmers, however, the custom is to leave the land in grass two or three years, and then take oats instead of wheat. Others, again, adopt a six-course, as follows:—mangolds, wheat, swedes, barley, seeds, wheat. This last would seem to furnish a very small proportion of summer-feed for the sheep, with a superabundance of roots, and can therefore only be followed where a large breadth of grass land is attached to the farm. It possesses, however, the rare advantage of giving every facility for keeping the land in perfectly clean condition, and might on this account be for a few years advantageously taken up on two or three of the farms we visited. Lastly, we met with one example of a seven-course, namely, 1. Mangolds and common Turnips; 2. Wheat, without Grass Seeds; 3. Barley; 4. Swedes; 5. Wheat, with Seeds; 6. Seeds, partly mown; 7. Oats.

Mangolds, though not largely, are certainly successfully grown throughout the district under consideration. Thirty-five to forty tons are no unusual crop; and, when properly stored in October or before the early frosts, they keep sound and juicy until after Midsummer. The kinds most in favour are the Long Red and Yellow Globe. When clean enough, and the weather favourable, the mangold ground is heavily manured in autumn (20 to 30 tons per acre), ploughed, and left for sowing as early in April as possible. The seed is generally planted in drills 26 to 27 inches apart, though some growers prefer them on the flat, especially in dry situations. At the time of sowing, from 6 to 10 cwts. of phosphatic manures, and 3 to 5 cwts. of common salt, are applied per acre in addition to the dressing of dung.

The treatment of swedes is similar to that for mangolds, except that the quantity of farmyard manure is less liberal, and dissolved bones, Kainit, nitrate of soda, and superphosphate, separately or mixed, form the auxiliary manures. They are for the most part sown on drills, and put in from the middle of May to the end of June. From one-third to one-half the swedes are generally taken home for consumption by the cattle-stock, while the remainder are pitted where they grow, or deposited on the poorer grass-fields and consumed by sheep. Early white or yellow turnips are but sparingly grown, the intention being simply to produce sufficient to maintain the lamb-stock during October and November, and a few for the ewes in hard weather. They are, however, extensively sown in the month of July, generally on the flat, after vetches, white mustard, trifolium, and such like catch-crops, have been consumed. Carrots and cabbages, beans and peas, are very little cultivated, and potatoes are seldom grown except for home consumption.

Wheat, though occasionally taken after roots, is more commonly grown upon the clover-leas. The autumn wheats are sown in October and November, and the spring sorts from the middle of January to the end of March. The varieties generally sown are Talavera, Chiddam, Velvet-chaff, Nursery, Browick Red, Biddell's Imperial, &c. To prevent smut, the seed is, for the most part, dressed with a solution of sulphate of copper (blue vitriol) at the rate of 1 lb. to 4 or 5 imperial bushels; the old-fashioned plan of depending upon brine and caustic lime having been entirely laid aside. Two-and-a-half bushels per acre is a common seeding, and an average crop will yield, in a tolerable season, 40 bushels, though on some of the best cultivated farms 50 bushels are not uncommon.

Barley, although in a few isolated cases taken after wheat, is almost invariably planted after roots, and drilled at the rate of 2 to 3 bushels per acre, according to the condition of the land

and lateness of the season. March, and up to the second or third week in April, is found to be the best time for sowing, the earlier period being preferred where land is in high condition. The seed-corn is, by some farmers, dressed, like wheat, with sulphate of copper. On some of the best barley land the yield reaches 45 bushels, 30 to 35 being considered fair on poorer soils. Oats, though seldom grown in Monmouthshire, are extensively cultivated under the influence of the more humid climate of South Wales. On farms where the 5 or 6 course is adopted they are taken after clover-lea. The land is ploughed up in December or January, well harrowed in March, and drilled at the rate of 3 to 4 bushels per acre. The white varieties are sometimes attempted, but the Black Tartar seems in most favour, producing as it does a heavy weight of well-filled grain, and abundance of bright nutritious straw. Some of the oats we inspected will barely yield 30 bushels, while a few patches will produce more than double that quantity. Along with the grain-crop (be it wheat, barley, or oats) succeeding the fallow break, clovers and grass-seeds are sown. The various mixtures differ little from those used in the North of England. A usual proportion is the following:—6 to 8 lbs. of red clover or cow-grass, 3 to 4 lbs. each of white and yellow clover, and 2 lbs. of alsike, together with  $\frac{1}{2}$  a bushel each of English and Italian rye-grass. Where land has become clover-sick (a very common occurrence where the 4-course system is strictly adhered to), a remedy is generally effected by varying the kinds of clover each alternate rotation. Thus, land sown this year with the red and yellow clovers, will, at the next seeding down, have cow-grass and Dutch-clover. With some the custom is to drill the rye-grass at the same time as—in fact, mixed with—the grain, and then sow the clovers by broadcast-machine. The commoner plan, however, is to mix heavy and light seeds together, and either sow them at the time the grain is put in, or when it has come through the ground, and will bear a light harrowing.

Where land is intended to remain down three or four years, 1 to 2 bushels of sainfoin per acre is sometimes added. Sainfoin, in fact, is very popular on the thinner limestone soils, and is often grown as a self-crop. In this case it is sown along with the wheat or barley, at the rate of  $2\frac{1}{2}$  to 3 bushels per acre, a little white or yellow clover being mostly added. The crop is cut for hay in June or July, and forms a delicious and fattening food, eaten greedily by any kind of stock. The aftermath is fed with sheep, which, if receiving a liberal allowance of corn and cake, keep up the manurial condition of the land, and insure a heavy crop of sainfoin for 8 or 10 successive years. The seed-break frequently receives a top-dressing of compost or farmyard-manure during the

autumn or winter, and about one-third the crop is generally made into hay. The clover-leas, as we have before said, are principally prepared for wheat; entirely so where the four-course system prevails, and the heavier and stronger the crop of clover the better will be the wheat. Where manure has not been previously applied to the seeds, a dressing of farmyard-dung is occasionally given; this is ploughed-in during October or November, and the seed drilled, or sown after the furrow-presser, as soon as possible.

Allusion has previously been made to the growth of trifolium, white mustard, vetches, &c., as catch-crops. The early harvests, and long mild autumns, are particularly favourable to this kind of culture; in fact, except mangold-ground, which is first wanted in the spring, many of the best managers never have any "idle fallow," that is, fallow not producing one or other of these forage crops between the harvesting of the wheat and the planting of the succeeding root-crop. We saw, during our summer inspection, several magnificent crops of vetches being mown and consumed by cake-eating sheep, and so luxuriant were they in some cases that we had doubts whether they could be finished in time to allow of the sowing of swedes or common turnips. Occupying the first position amongst these valuable supplements to the spring food is trifolium (*Trifolium incarnatum*), and we may therefore be pardoned if we give a short account of its cultivation. Immediately the wheat-crop is off (for trifolium should, if possible, be sown in August) the land is skimmed or very lightly ploughed, harrowed, and Cambridge-rolled; where the stubbles are clean, ploughing is often dispensed with. From 20 to 30 lbs. of seed per acre is sown by hand or broadcast-drill, well harrowed and rolled. By the middle of November, in a favourable season, the ground is completely covered, and the trifolium comes in for cutting about the end of April. A portion of the field is generally top-dressed, so as to give a supply before the bulk is ready for use. Being somewhat strong and coarse, trifolium, in its green state, is more commonly given to cattle and horses than to sheep. Should any remain unconsumed at the end of June it is made into hay, and this, especially if cut early and not allowed to heat much in the stack, rivals even sainfoin in quality, and in beneficial results produced when given, whole or chopped, to fattening sheep. White or green tankard turnips, dressed with farmyard-dung, are generally taken after trifolium. These are eaten by the lambs or ewes, according to their respective wants, before Christmas.

Throughout South Wales and Monmouthshire alike machinery is rapidly taking the place of the scythe for the cutting of hay-grass and grain. Owing to the twisted condition of some of the



clover-crops, the scythe will this year be more in requisition, but the high prices (5s. to 6s. per acre) now asked for mowing will soon cause its disuse. In the winning of the hay nothing new presented itself. The crop is generally put in oblong stacks, and, from the large size of most of these, and the richness of the herbage, the hay requires to be thoroughly dry before being carted.

All the grain, with the exception, in a few instances, of the barley-crop, is bound up and stooked, ten, and in some cases twelve, sheaves going to the stook. In Wales, owing to the moist atmosphere, "hand mows," or small conical stacks, of 50 to 60 sheaves each, as seen in Scotland, are occasionally made. Excellent harvest-waggon, chiefly by local makers, are used for the carting of the grain.

The barley ricks are for the most part oblong, and of large dimensions, while the wheat and oats are put in round stacks of from 20 to 40 quarters each; the thatching and finishing off being in both cases well and neatly done.

Except in some of the small hill-farms, and where mere patches of corn are cultivated, grain is threshed out by steam-driven machines supplied by the best makers. Many farmers let the threshing, and tying of the straw in bundles, to persons who go from farm to farm for the purpose, at so much per bushel; generally at 2d. per bushel for oats, and 2½d. to 3d. for barley and wheat.

Many and varied are the breeds of cattle in the farm-prize district; and we say, unhesitatingly, that the weak point in the farming of Monmouthshire, equally with that of Wales, lies in the cattle management. In one solitary instance we met with a few choice Shorthorns of pure pedigree, and there are undoubtedly many fine herds of Herefords and Welsh cattle; but on the majority of farms we found nothing but ill-bred, shapeless mongrels. Not that we would recommend the introduction of Shorthorns into every district; far from it; but we think greater attention to symmetry, purity of breed, and early maturity, would be productive of the best results. With draining, too, and the general march of improvements, the docile and easily kept Hereford might be advantageously pushed further westward. Unquestionably the black Pembroke, so similar to, yet, we understand, quite distinct from, their Glamorganshire neighbours, are suited to a high, cold, and damp locality; but even these might be marvellously improved by more liberal feeding, and by the exercise of greater care in the selection of sires and dams. Had breeding and perfection of outward form been sacrificed for the sake of milking qualities, we could in some measure have pardoned the neglect; but, seeing that little attention is given to dairy-farming throughout the district under consideration, there is no excuse for having a race of nondescripts.

With the sheep-farming we cannot find much fault ; in fact, this branch is in general above an average, and forms a striking contrast to the careless indifference and inattention too evident in the cattle management. Good Cotswolds and Oxford Downs, with a few flocks of Leicesters and Shropshires, flourish on the lowland farms, and these are in a few cases used for crossing the native breeds. Great care is taken to select purely-bred, massive, well-woolled tups, for the purchase of which many of the leading breeders regularly attend the Gloucester September fair. Put to ram about the 1st of October, the ewes drop their lambs at the beginning of March. The crop is not large, one-third twins being considered a fair increase. At the end of June, or early in July, Cotswold lambs are shorn on some farms, and yield about  $2\frac{1}{2}$  lbs. each of fine wool. This plan, of course, tells against both the quantity and quality of the next year's clip, but the loss is more than compensated for by the greater progress made by the sheep during the winter months. On the stiff clay soils, where the land soon becomes poached, the additional comfort given to the animals by being rid of their long coats is very marked ; and in one instance particularly, where the two systems of shearing and non-shearing were being tried in juxtaposition, we at once declared in favour of the former treatment. Lambs, in the hands of the best breeders, are taught to eat cake at an early age. In September they go to white turnips, which they sometimes eat whole, and early in December they are placed on cut swedes. As time goes on the allowance of extra feeding-stuffs is varied and increased. Peas, linseed or cotton cake, Indian corn, crushed oats, &c., besides forcing on the animals very rapidly, keep up the condition of the land, and lower the manure bills. At thirteen or fourteen months old the wether tegs are fit for market, the heavier breeds not unfrequently reaching 90 lbs. per carcase. The management of the ewes during winter is in no way inferior to that of the lamb stock. Hay, when they will eat it, is dealt out unsparingly, and a moderate quantity of roots, commonly white turnips, is given, mainly on the pastures. Thus, by close attention, and careful, without wasteful treatment, the health of the flock is well maintained, deaths are reduced to a minimum, and the critical time of yeaning is got through without serious difficulty. The free and timely use of much-praised dipping mixtures keeps the sheep stock cleanly, and we saw but one case of that perpetual annoyance to the shepherd, scab. Foot-rot, however, especially in the lower and damper situations, prevails considerably. One of the best curative dressings is found to be gunpowder and blue vitriol, in equal parts, mixed up with linseed oil, and the too close paring of the foot is strongly deprecated.

Nowhere, in following our judicial functions, were we thrown in contact with any large breeder of the far-famed and justly celebrated Welsh "Nag." We must, therefore, pass over, without further comment, this very interesting and important branch of Welsh farming. The agricultural horses met with were generally small, and, although active and wiry, were wanting in symmetry and power, and would be greatly improved by the infusion of Clydesdale blood. The treatment of the farm-horses is in a few cases peculiar. While stabled by some in winter, and turned out to grass in summer, there are many farmers whose cart-horses always lie in large open yards at night, six or eight—the whole lot, in fact—together, and are tied in the stalls morning and evening to receive the best part of their food. Again, we met with one very good and intelligent farmer, whose four regularly used horses have never "laid in" for eleven years; we refer to Mr. Henry Price, of Undy, near Chepstow. Receiving their corn and hay in a low, dark stable, these horses are turned into an adjoining paddock for the night, and although, as may be inferred, not very sleek in the coat or beautiful to look at, they appear healthy and in fair working condition; in fact, not one of the four has ever been off work during the period of time mentioned. Need we say that this is strong evidence that the winter is much milder, and the temperature many degrees higher, than in the north of England? On many of the farms we visited, the activity and endurance of the horses are often severely and wastefully taxed by the scattered and isolated situation of many of the fields; portions of the farm, even in small holdings, being not unfrequently  $1\frac{1}{2}$  to 2 miles distant from the inconvenient and inadequate premises.

Pigs, if it be possible, receive even less attention than the cattle-stock, and are as varied in colour as they are untraceable in breed. Surely, if a thing is worth doing at all it is worth doing well, and we would strongly urge the desirability of bestowing more pains on these useful and highly profitable scavengers of the farm.

One remarkable circumstance, not to say serious drawback, in connection, not only with the farms we examined, but, according to information we gathered, applying to the entire district, is the almost total absence of leases, or even of ordinary written agreements. It is usual to blame the landlords for omissions of this kind; but in this case, at least, we believe the tenants are more in fault. At any rate, while we heard of no large landed proprietor having refused to grant leases to deserving applicants, we were told that one owner of vast and well managed estates had offered this boon to his farmers, and yet, during two years, only three have come forward to claim the proffered privilege. However, be the blame where it may, we are strongly opposed to

this uncertainty of tenure: it seriously retards the progress of agriculture, diminishes outlay by the tenant in permanent improvements, checks the liberal application of permanent manuring substances, and therefore hinders the thorough development of the resources of the soil.

Picturesque though primitive, prettily though often inconveniently placed, the Welsh homesteads are more especially conspicuous by means of the profuse covering of whitewash with which not only the walls, but even the roofs of the buildings, are commonly besmeared. This outside coating of the slates, resembling very much our North Country "rendering" of the inside, besides imparting an air of cleanliness, is useful alike in keeping out the driving storms of winter, and in giving additional coolness during the summer months. The farm premises, as a rule, are deficient; the large open yards have too often insufficient shed-room: spoutless buildings help to dilute more effectually the already well-washed manure; the animal heat, instead of being sustained as far as possible by artificial means, is wasted by undue exposure to cold and damp. We have had occasion, in the earlier part of this Report, to complain of the inferior quality of the cattle, both in Monmouthshire and South Wales. This defect, need we add, is, in some degree, traceable to the careless and improper manner in which the young stock especially are housed during the winter. There are, however, exceptions to this state of things. Some tenants, having undertaken to do the haulage free, and, in rare instances, to bear a further share of the expense, have recently had admirable additions made to their steadings. None of the principal landowners withhold any reasonable expenditure in necessary improvements, and we therefore believe that what we have here said respecting the want of shelter for the cattle-stock will not in a few years' time apply.

Agricultural labour, at all times forming a very heavy item in the expenses of a farm, has, during the last six or eight months, been a source of real anxiety, if not of alarm, to the arable farmer. Strikes and labour-unions, although they have not yet extended into the Principality, have had their natural influence; and wages, both here and in Monmouthshire, have, since Christmas, advanced about 15 per cent. Proximity to mines and thriving manufactories, the rapid extension of railways, and the springing up of a large export and import trade, have for some years absorbed surplus labour, and wages have been considerably higher than in the southern and midland counties. Good ploughmen and waggoners, where no perquisites are given, are now earning 15s. per week; while those for whom cottages are found are paid generally 13s. or 13s. 6d. Ordinary labourers, having task-work occasionally, but no extras, receive 13s. to 14s.

Married men, besides having coals carted free, are mostly allowed from one-eighth to one-tenth of an acre of potato-ground—tilled, dunged, ploughed up, and the crop carted home. Women seldom work in the fields; and boys, owing to the horses being sensibly yoked in pairs, are not in so great request as where the reprehensible practice of driving a string of three or even four horses still prevails. As helpers to the cattleman and shepherd, however, and for root-pulling, weeding, turnip-hoeing, and other light jobs, two or three boys are generally employed on every farm, and their wages run from 4s. 6d. to 7s. per week, according to their age and ability. Single men, boarded and lodged in the farm-houses, receive, according to their capabilities and experience, 15*l.* to 25*l.* a year. Labourers' dwellings, though often placed in the nearest village, and therefore not so convenient as if dotted about the farms, are not wanting on some of the holdings we inspected. On others, however, there was the usual outcry for greater cottage accommodation, as being the only means of guaranteeing a regular and effective supply of farm-labourers. At the present time numbers of workmen, we were told, trudge several miles to and from their work; and hence they are easily induced, when an opportunity offers, to undertake more attractive, because generally more lucrative, work nearer home. Farmers, however, with the introduction of improved machinery, and the consequent greater necessity for skilled labour, cannot afford thus to lose the best of their hands; and the supplying of comfortable and conveniently placed homes for intelligent, well-trained servants, would seem to be the most rational and effectual means of stemming this drawing off of shoals of first-rate men from the healthful work of the farm.

Besides the money-payments and perquisites above-mentioned, workmen and workwomen, of all ages, are, on the majority of the competing farms, supplied with cider or, failing that, with beer, throughout the year. "Drink," remarked the Monmouthshire farmers; "Drink," re-echoed those of the Welsh tenants to whom the cider traffic extends, "is the curse, the bane, of our labouring population!" Throughout the year men are commonly supplied with two quarts of cider each per day, and women and boys with one quart; while, in the busy times of hay and corn harvest, there is hardly any limit to the quantity consumed. Three gallons per man is no unusual daily allowance, and the consequence is, that, long before night—in fact, during the greater part of the day—the men are not unfrequently in a state of semi-intoxication! We were informed of one confirmed and well-seasoned toper who, when asked to undertake rather an extra day's work of thatching (at which he was remarkably

clever), could only be induced to begin by the promise of a liberal allowance of "drink." Instructions to this effect were accordingly given to the proper party, and a request added that an account be kept of the measure served out. Twenty-seven well-filled pints did our thatcher consume! and then, with the work only half finished, and that badly performed, he reeled, or rather crawled, to the kitchen door for more! This, however, may be, and we hope is, an exceptional case; but, in the districts referred to, the health, happiness, and independence of the labouring class are undoubtedly interfered with by the too-frequent indulgence in intoxicating drinks.

On large farms, and especially in busy seasons, the filling of the "caskies," or small wooden kegs, almost takes up one person's time; for those doing task-work, as mowing, turnip-thinning, &c., equally with the day labourers, expect an allowance of so much "drink" per acre. Cider, however, is one of the natural products of Monmouthshire and certain parts of Wales. The soil is, in many places, peculiarly suited to the growth of the apple; for instance, on one farm of 200 acres we found 13 acres of thriving orchard-ground; and it is therefore with t e great abuse, and not the temperate use, of this beverage that we are inclined to quarrel. Milk being hardly obtainable by the poorer classes, cider or weak beer is a convenient substitute; but might not the two quarts measured out to the husband be shared with the wife and children at home? But no: when more than once we ventured to suggest this to married men, our simplicity only produced a significant smile! Hodge would drink as much more without thinking of those whose domestic duties and home-cares may be far greater than his own labour! Some sensible men, be it noted in extenuation, seeing the folly of imbibing so much liquor, have asked to be paid, and are now receiving, 3*d.* per day throughout the year in lieu of cider or beer; and the farmers, generally, would be glad to have this perpetual doling out of drink reduced to a money payment. Legislative interference seems not unlikely to come to their aid; and, if the result be the stopping of all remuneration of labour in kind, it will be an invaluable boon to employers, and an immeasurable source of health, wealth, and happiness, to the labourers themselves.

One word of suggestion as to the future, before we end our remarks. Should this system of farm-competition continue in favour with the Royal Agricultural Society (and we trust it may do so, as it cannot fail to be productive of much good), we would strongly urge the desirability of dividing the farms into two classes; say, holdings of over 70 and not exceeding 150 or 200 acres, and those of a greater extent than this. Every one will admit the difficulty experienced by judges where, as in

our case, they have to compare the merits and demerits of farms varying in size from 105 to 482 acres, and a much greater diversity even than this might very easily have occurred. A classification such as we have named would materially lessen this objection; the prizes might be in keeping with the extent of the farms; and the cost of inspection, which is the main item of expenditure, would only be increased by greater and keener competition.

Lastly, in closing this Report, we would express the pleasure we experienced in traversing a beautiful and highly interesting country, and in discoursing with farmers of great experience and ability. In farming, as in every other branch of industry, there are, and ever will be, different degrees of excellence; but as regards hospitality, courtesy, and willingness to impart all necessary information, there was complete uniformity amongst the whole of the nineteen competitors. The warm reception and cordial co-operation we met with from one and all have made a lasting impression upon us, and we shall ever look back with the most agreeable recollections to the twenty hard-working days we spent in South Wales and Monmouthshire.

(Signed)

THOMAS BOWSTEAD.

THOMAS JENKINS.

FINLAY DUN.

---

XV.—*The French Peasant-Farmers' Seed Fund.* By H. M. JENKINS, F.G.S., Honorary Secretary of the Fund.

THE progress of the recent war between France and Germany had, at the end of 1870, resulted in the occupation by the German army of an extensive tongue-shaped tract of country stretching from the Franco-German frontier on the east almost to the confines of Normandy on the west. The southern boundary of this occupied territory roughly coincided with the valleys of the Loire, Indre, Saone, and Doubs; while on the north-east it reached to the Belgian frontier, and on the north-west almost to the coast of French Flanders. The non-combatant inhabitants of this district were as completely cut off from the rest of the world as were the besieged inhabitants of Paris. The harvest of the small farmers had in many cases never been reaped, and those who had been more fortunate were compelled to surrender their stores, whether of corn or meat, to one or other of the contending forces. To keep the wolf from the door was the absorbing consideration, and how to sow their land in the spring was a problem which the small cultivators had been unable to attempt to solve. Even those who had managed to sow autumn wheat, and who

had thus expected to avoid starvation, found themselves deprived of their last hope by the extreme rigour of the winter, which almost entirely destroyed the plant over the greater portion of the north of France.

Such was the condition of affairs when, at the General Meeting of the Members of the Smithfield Club, the President (the Earl of Powis) mentioned in cordial terms of approval a correspondence between his Excellency M. Drouyn de Lhuys and Mr. James Howard, M.P., in reference to a project for supplying seed to the small cultivators of the invaded region. This correspondence was subsequently published in the agricultural newspapers at the instance of the Honorary Secretary of the Club, Mr. Brandreth Gibbs, who at the same time announced his readiness to register donations of seed-corn and other contributions. Notwithstanding this, it seemed probable that the movement would not be successful unless some steps were taken that would inspire with confidence those who were desirous of assisting the distressed French peasant-farmers. Accordingly, a public meeting was called by Mr. Brandreth Gibbs, Mr. Delano (the Honorary Agent in England of the 'Société des Agriculteurs de France'), and myself, and we were afterwards appointed joint Honorary Secretaries of the Seed Fund. Fortunately, Lord Vernon, then President of this Society, consented to preside at the meeting, and afterwards to become the Chairman of the Seed Fund Committee.

At this meeting, which was held on December 19th, for the purpose of appointing a Committee to collect subscriptions in corn and other seeds to be supplied gratis to the suffering peasant-farmers of France, thus enabling them to sow their land and avoid an otherwise inevitable famine, the following statement, addressed to Lord Vernon by Mr. Howard, was read in explanation of the origin of the movement:—

“I would very briefly explain why I was induced to take up the subject of assisting the French cultivators. In the early part of October I met with friends from France who gave such a description of the desolation wrought by the contending armies, and the utter ruin which seemed inevitable to the farmers of France, unless by extraneous aid they could be supplied with seed wherewith to sow their fields, that, after consulting with members of the Farmers' Club, of which I am the Chairman for the year, I at once wrote to his Excellency M. Drouyn de Lhuys, the President of the French National Agricultural Society, to ask his advice and co-operation. It was my intention on receiving his reply to put myself in communication with your Lordship as President of the Royal Agricultural Society, and other leading men in agriculture; but on the very day I received the reply of M. Drouyn de Lhuys, I was seized with an illness



which prostrated me for a month. As soon as I began to recover I wrote to his Excellency to say that I felt unable to prosecute the scheme, and recommended him to address the Earl of Powis on the subject; for as the Cattle Show was at hand, his Lordship, as President of the Club, would have an opportunity of bringing the subject before the farmers of England. I am very glad that the question has been taken up by your Lordship and other influential men connected with agriculture, and I have no doubt that the farmers and landed proprietors of England will respond to the call for their aid in a manner not only gratifying to the general British public, but which will gladden thousands of the cultivators of the soil of France, and probably for generations beget in their minds and hearts kindly feelings towards the English people."

Mr. Howard's illness unfortunately continued in a more or less severe form for several months, but he acted throughout as Honorary Treasurer of the Fund, and took as active a part in its operations as the state of his health would permit.

An Executive Committee was afterwards nominated on the principle that every branch of the agricultural interest should be duly represented, and it finally consisted of the following members, in addition to the honorary officers already mentioned:—Messrs. T. Aveling, James Caird, C.B., J. Algernon Clarke, Henry Corbet, and Millis Coventry, Capt. Dashwood, Capt. Delf, Major-General Sir Vincent Eyre, K.C.B., G.C.S.I., and Messrs. J. Furley, W. Harris, G. Horne, A. Mongredien, J. Odams, P. Pavy, C. B. Pitman, C. S. Read, M.P., N. Rix, and W. Wells, M.P.

The first duty of the Executive Committee was to take the measures necessary for the collection of subscriptions in cash as well as in corn. For this purpose they endeavoured to establish county committees consisting of prominent agriculturists, and including the President and Secretary of every Agricultural Society, Farmers' Club, and Chamber of Agriculture in the kingdom. Many of these committees worked exceedingly well, but in other districts the ground was better occupied by the pre-existing committees of the various agricultural associations. Both results were satisfactory to the Seed-Fund Committee, and encouraging to those who are endeavouring to perfect the organization of farmers' clubs and other agricultural institutions in the districts in which their operation is still limited. The Committee also appealed to the Boards of Guardians throughout the country, and they rendered most efficient assistance in the collection of subscriptions. I state this fact in thankful recognition of the exertions of the Boards, and also as an evidence of the thorough manner in which they represent the agricultural interests of the country. The French Peasant-Farmers' Seed-Fund was, in fact, an essentially agricultural movement, and the

Committee therefore endeavoured to make its object known, as far as they could, to every landowner and tenant-farmer in the kingdom. The result, classified in counties, was approximately as follows, as regards the subscriptions in money:—

*England:—*

Bedford .. ..	£497	3	0
Berks .. ..	482	15	9
Bucks .. ..	249	13	5
Cambridge .. ..	661	2	10
Chester .. ..	143	5	3
Cornwall .. ..	71	7	0
Cumberland .. ..	276	16	7
Derby .. ..	405	14	0
Durham .. ..	82	8	8
Devon .. ..	333	18	5½
Dorset .. ..	183	8	8
Essex .. ..	777	7	0
Gloucester .. ..	1064	16	7
Hants .. ..	415	17	1
Hereford .. ..	226	6	7
Hertford .. ..	399	9	3
Huntingdon .. ..	141	1	5
Kent .. ..	1526	18	11
Lancaster .. ..	387	6	0
Leicester .. ..	420	18	0
Lincoln .. ..	338	2	4
Middlesex 271 3 6	} 4236	14	10
London 3965 11 4			
Monmouth .. ..	166	16	10
Norfolk and Suffolk	1977	19	2½
Northampton .. ..	508	11	10
Northumberland .. ..	827	1	1
Nottingham .. ..	107	1	8
Oxford .. ..	471	3	5
Rutland .. ..	90	0	11
Shropshire .. ..	664	3	6
Somerset .. ..	666	5	5
Stafford .. ..	380	9	7

Surrey .. ..	£272	15	4
Sussex .. ..	820	5	3
Warwick .. ..	1044	4	8
Westmoreland .. ..	154	3	6
Wilts .. ..	464	14	9
Worcester .. ..	962	0	7
York .. ..	929	12	1

*Wales:—*

Anglesey .. ..	£7	0	0
Brecon .. ..	159	18	2
Cardigan .. ..	..	..	..
Carmarthen .. ..	34	11	7
Carnarvon .. ..	19	3	9
Denbigh .. ..	42	2	6
Flint .. ..	40	10	0
Glamorgan .. ..	216	17	3
Merioneth .. ..	2	18	10
Montgomery .. ..	62	19	2
Pembroke .. ..	45	14	3
Radnor .. ..	32	10	10

<i>Scotland</i> .. ..	£393	8	5
-----------------------	------	---	---

<i>Ireland</i> .. ..	69	9	6
----------------------	----	---	---

Belgium .. ..	£7	0	0
France .. ..	5	0	0
Hungary .. ..	1	0	0
Italy .. ..	25	0	0
Jamaica .. ..	7	0	0
Jersey .. ..	13	1	6
Switzerland .. ..	10	0	0
New York .. ..	7	6	3

## TOTALS.

England .. ..	£26,850	4	9
Wales .. ..	624	6	5
Scotland .. ..	393	8	5
Ireland .. ..	69	9	6
Foreign Countries .. ..	75	7	9
Anonymous .. ..	1266	7	11
Subscribed by persons giving no address .. ..	2894	13	8

	£29,167	1	2
Lord Mayor's Fund .. ..	13,000	0	0
Swedish Fund .. ..	6300	2	0
Limbourg Fund .. ..	393	14	0
Refunds, Interest, &c. .. ..	3078	11	5

Total .. .. £51,939 8 7

The large towns were not directly appealed to, but the object of the Fund commended itself to a large number of citizens who sympathized with the French peasantry as well as with the starving population of Paris. The subscription list, therefore, includes a considerable proportion of urban donations, and it was supplemented by three grants, amounting in all to 13,000*l.*, from the Mansion House French Relief Fund, which was specially established for the supply of food to the starving multitude shut up in the French capital. Afterwards, when the organization of the Seed Fund had been fully developed, a Swedish Collection, amounting to 6300*l.*, and a Limbourg Fund, amounting to 393*l.*, were placed in the hands of Lord Vernon by his Excellency M. Drouyn de Lhuys, who had throughout been the willing guide and counsellor of the Committee in all matters on which they desired his advice. These various sums, together with refunds for railway charges, made a total of nearly 52,000*l.* with which, from first to last, the Committee had to deal.

The corn and other seeds bought by the Committee were augmented by donations in kind amounting to about 180 quarters of spring wheat, 600 quarters of barley, 350 quarters of oats, about 300 sacks of potatoes, and numerous sacks and bags of small seeds, including turnips, swedes, mangolds, vetches, &c. &c. The representatives of the Fund also distributed large quantities of wheat, barley, oats, and potatoes for the Scotch and Irish Committees, as will appear in detail under the heads of the several *dépôts*.

At an early stage of their proceedings the Committee addressed themselves to the pressing duties of ascertaining the wants of the peasant-farmers, of purchasing the seeds which were most needed, of transporting them to France, and of distributing them in the occupied region. For the first-named purpose, they circulated the following schedule of questions amongst the chief resident officials and agriculturists in the most exhausted districts, through the medium of the representatives of the English press, of the National Society for Aid to the Sick and Wounded in War, and by the assistance of numerous private individuals:—

#### AGRICULTURAL REQUIREMENTS OF FRANCE.

1. What are the agricultural features of your district in the following aspects?

**A** Kinds of grain and other seeds generally used for sowing.

**B** Kinds deficient at the present time.

**C** Latest period of spring sowing.

(a) Spring wheat, if grown.

(b) Spring beans or peas, if grown.

- (c) Barley.
- (d) Oats.
- (e) Clovers and grasses.
- (f) Turnips and other roots.
- (g) Potatoes.
- (h) Tares and other fodder crops.
- (i) Any other crop extensively grown in the district.

**D** What means of cultivating the land are at present possessed by the peasant-farmers of the district, viz. :—

- (a) By men.
- (b) „ women and children.
- (c) „ horses.
- (d) „ oxen and other animals.
- (e) „ implements.

2. Can seeds for spring sowing be bought in the district; or, if near the frontier, at any dépôts across it; and, if so, at what price?
3. What means are possessed by the farmers of the district to enable them to purchase seeds?

A large number of replies to these questions were received from all portions of the invaded region, and they revealed a state of exhaustion of the agricultural community that rendered the knowledge almost more perplexing to the Committee than their original ignorance. It was, however, obvious that too much seed-corn could not be sent into districts in which, according to these statements, it was “entirely wanting;” and it was satisfactory to receive repeated and distinct assurances from experienced agriculturists that the latest period of sowing spring wheat was not until March 15th, and in some districts April 1st, while oats and barley were commonly sown until April 15th, and in some districts until the beginning of May. As the information clearly showed that the wants of the peasant-farmers were infinitely greater than there was any likelihood of the Committee being able to supply, it was a matter of necessity to limit the distribution to *bonâ fide* peasant-farmers who had suffered by the war, and to restrict the quantity given so as to extend the donations of the Fund to the greatest number of persons while conferring a substantial benefit in each case. The Committee, therefore, decided to instruct their representatives, who were charged with the distribution of corn and seeds, not to allow claims made by persons occupying more than 50 English acres (20 hectares), and not to give to any occupier more than 8 bushels of wheat, or 12 bushels of barley, or 16 bushels of oats, or a proportionate quantity of

two or more kinds of grain. Generally speaking, the representatives of the Fund found it desirable to restrict still further both the area of occupation and the quantity of grain given in each case, and thus a proportionately larger number of persons received relief.

It will be remembered that the capitulation of Paris took place on the 28th January, 1871, and was not succeeded by the signature of the preliminaries of peace until the 26th February. At the former date the subscriptions promised amounted only to about 2000*l.*, of which not more than 900*l.* had been received, and it was not until nearly the latter period that the list of donations gave indications of assuming the proportions which it ultimately acquired. In the mean time the Committee were urged on all hands to send out spring wheat, which could not be bought in the occupied districts for love or money, while the difficulties of transport from the sea-coast to the interior rendered the arrival of the seed in time for sowing a matter of the utmost uncertainty. In addition, the desirability of attempting to commence the work of distribution was a question difficult to decide. The Committee, therefore, on January 30th, called a general meeting of the subscribers to determine whether a commencement should be made in view of the prospect of an early peace, and the result was that the first purchase of wheat was made on February 4th, and subsequent purchases as frequently as the subscription list would permit.

The Committee were fortunate in obtaining, at the outset, the co-operation of a delegation appointed by the Committee of Corn-merchants on Mark Lane, and to the disinterested co-operation of these gentlemen no inconsiderable share of the success of the operations of the Fund is fairly due. Through their agency the corn and other seeds were bought at exceedingly favourable prices, and without any charge for commission, while their quality evoked the admiration of the peasant-farmers in every district to which the consignments of the Fund were sent.

Those who remember the demand for spring wheat on Mark Lane in February, March, and even in April of 1871, will readily understand the difficulty experienced by the executive officers of the Seed Fund in their endeavour, first of all to collect, and afterwards to despatch to France, several thousand quarters of that grain. The collection was made over the several lines of railway leading to London, all of which were more or less choked with merchandise intended for the relief of the population of Paris and the North of France. The despatch had to be conducted in the face of difficulties in the way of obtaining steamers to carry the grain to the French ports, and of almost insuperable obstacles across the channel in consequence of the lack of railway waggons in France, except those used by the contending forces for

the conveyance of troops. Mr. James Odams, however, was not only indefatigable in his efforts to charter suitable steamboats for the conveyance of the grain to the French ports of landing (Boulogne, Honfleur, and St. Nazaire), but he placed Plaistow wharf gratuitously at the command of the Committee for the reception of the donations and purchases, amounting to several thousand quarters of grain. Thanks to him, the shipping department was most satisfactorily conducted, and the grain sent to France without delay. On the other side of the Channel the difficulties were very great; but at Boulogne the local Committee of the Sick and Wounded Fund, who also acted for the Seed Fund, induced the Northern Railway of France to enter into the spirit of our enterprise so thoroughly that they not only carried our consignments free of charge, but gave them precedence over all merchandise. Months afterwards, the wharves and stations at Boulogne and Calais were encumbered with bales and sacks that had been waiting their turn ever since the termination of the war; meanwhile, the seed sent by the Fund for the most part arrived in time for spring sowing, and the comparatively small quantity that arrived too late was sold for grinding, at remunerative prices. This result was in great measure due to the exertions of the Chairman of the Boulogne Committee, Sir Vincent Eyre, and the Secretary, Mons. V. J. Vaillant, aided by the generous co-operation of General von Goeben, the Commander-in-Chief of the German Forces in the North of France.

It may be considered paradoxical to state that one of the greatest difficulties experienced by the Committee was brought about by the success of their own operations; but so great was the want of seed-wheat in France, and so difficult was the question of transport into the occupied region, that the Committee were flooded with applications either to purchase on account of French cultivators outside their definition of a peasant-farmer, or to sell them wheat at a reduced price. In fact, such applications coming in every conceivable form, backed by the recommendations of the most influential men, made it very difficult at times to say an emphatic "No" to the entreaties of our most respected friends; but the Committee firmly though reluctantly resolved that it would be inexpedient to allow a charitable fund to degenerate into a trading company under any guise whatever.

#### SPRING DISTRIBUTION.

As will have been understood, the answers obtained to the schedule of questions as to the agricultural requirements of the peasant-farmers, not only showed the extreme want of seed-corn, but exhibited a surprising demand for spring-wheat,

partly in consequence of the destruction of the autumn-sown wheat by both the war and the weather, and partly in consequence of the exhaustion of the country in materials available as food for the people. The first purchase of seed-corn was ordered, as already stated, on February 4th, viz. 300 quarters of spring wheat, to be distributed in the Department of the Somme from a dépôt at Amiens, by Mr. C. Sartoris, of Wilcote, Charlbury, Oxfordshire; but the operations of the Fund assuming an importance not originally contemplated, Mr. Sartoris soon found it necessary to avail himself of the assistance of Colonels Cox and Berington. Afterwards, Mr. Sartoris being obliged to return to England, Colonel Cox was placed at the head of the Amiens dépôt, and Colonel Berington distributed in the adjoining department of the Pas de Calais, from a dépôt established at Arras. The area of distribution was further extended, at a more recent period, to the Department of the Aisne, in an easterly direction towards the Ardennes, where Mr. Bullock had been distributing "The *Daily News* Fund." Thus, the original area was, step by step, extended in every direction until it reached the boundaries of districts that were either supplied from other dépôts subsequently established, or, as in the case of the Ardennes and the Meuse, the confines of regions that were under the special charge of the "*Daily News*" and the "War Victims' Fund" Committees, to whom grants of money were made by the Seed Fund for the purchase of seed-corn.

The quantities distributed in the departments of the Somme, Aisne, and Pas de Calais, were, in round numbers, 1000 quarters of spring wheat, 1450 quarters of oats, 1050 quarters of barley, and about 100 tons of potatoes sent by the English Seed Fund. In addition 168 sacks of wheat, 1060 sacks of oats, and 1536 sacks of potatoes, sent from Scotland by the Edinburgh Committee, were distributed chiefly in the Pas de Calais. One hundred quarters of vetches, 1000 half-pecks of haricot beans, 1000 quarter-pecks of turnip seed, 1000 two-pound packages of carrot seed, and 1000 quarter lbs. of onion seeds were also sent to the Department of the Aisne. The total number of occupiers relieved in these departments is as follows:—

Departments.	Seed Corn.	Potatoes.	Total.
Somme .. ..	11,012	4401	15,413
Pas de Calais .. ..	2,083	850	2,933
Aisne (approximate) ..	..	..	8,000
Total (approximate)	..	..	26,346

The capitulation of Paris on the 28th January having been succeeded by the signature of the preliminaries of peace on the 26th February, the latter event was followed by a large influx of subscriptions.

On February 21st the Lord Mayor's Committee made their first grant of 5000*l.* to the Seed Fund. It was therefore determined, on the following day, to purchase 1500 quarters of spring wheat for distribution in the district of La Beauce,—the principal grain-producing region of France. Colonel Elphinstone superintended the distribution in this district, the history of which offers a close parallel with the course of events just described. The wheat bought with the Mansion House grant was followed by oats, barley, &c., purchased with our own subscriptions, and Colonel Elphinstone availed himself of the assistance of Captain Rennick and other gentlemen. Mr. Miles Lewis was also engaged by the Committee to travel with the grain from Honfleur to Tours and elsewhere,—a precaution, the necessity of which was fully borne out by experience. By these means the whole of the grain sent to this district was satisfactorily distributed, and without delay, the quantities having been as follows:—

1650 quarters of wheat, 1040 quarters of barley, and 810 quarters of oats, sent by the Seed Fund direct; also 4280 sacks of potatoes, 394 sacks of oats, and 20 sacks of various kinds of seed, sent by two Irish Committees at Dublin and Waterford. The English Committee further sent 50 quarters of spring tares, and 4000 packets of small seeds, of the same description as those sent to the Aisne; and they also paid 1000*l.* towards the cost of one of the cargoes sent by the War Victims' Fund. For this 1000*l.* Colonel Elphinstone received for distribution 3500 bushels of oats, 338 sacks of barley, and 158 sacks of potatoes. Unfortunately this consignment reached him so late that the period of sowing oats in that district had expired, and it became necessary to sell them for fodder; but the sum realized, nearly 4*s.* per bushel, showed a gain rather than a loss, and the Committee authorized him to expend the amount in the purchase of maize in the South of France.

Departments.	Seed-corn.	Potatoes.	Small seeds.	Total.
Indre et Loire	3,021	2,832	394	6,247
Sarthe .. ..	738	652	117	1,507
Loir et Cher ..	5,760	4,871	522	11,153
Loiret .. ..	4,150	1,309	314	5,773
Eure et Loir ..	3,170	1,096	393	4,659
Total ..	16,839	10,860	1,740	29,339



The district of La Beauce comprises portions of the departments in the preceding table, which shows also the number of occupiers relieved in each, exclusive of those who received the tares and garden seeds.

A second vote of 5000*l.*, made by the Lord Mayor's Committee, on February 24th, coupled with a large influx of subscriptions, enabled the Seed Fund Committee to establish a dépôt at Paris for the relief of the small cultivators in the extensive region which had been devastated during the protracted siege of the capital of France. Mr. J. Furley, of the National Aid Society, Mr. R. N. James, Mr. Pitman, and Mr. Mansfield, undertook the distribution of a large quantity of wheat, barley, and oats from a warehouse at Paris which had been provided free of cost through the instrumentality of the officers of the "Société des Agriculteurs de France." With every prospect of a successful distribution, this Committee commenced its work, and about 500 quarters of seed-corn were sent into Paris and partially distributed in the southern rural districts, with the assistance of Mr. Norcott, the representative of the Lord Mayor's Committee; but, in consequence of the insurrection in Paris, it was soon found necessary to remove the dépôt to Creil.

To Paris and Creil, about 800 quarters of spring wheat, 1150 of barley, and 1425 of oats were sent, also about 300 tons of potatoes, and 4000 packages of small seeds as in the other cases. The books of the representatives showed that about 2500 occupiers resident in between 40 and 50 Communes south of Paris, and about 4300 occupiers resident in 127 Communes north of Paris received relief from Paris and Creil respectively. The following table is sufficiently complete to indicate the nature of the distribution, though several of the returns, showing the number of persons relieved in certain communes, were lost in transmission through the post at the time of the Communist insurrection:—

Departments.	Wheat.	Oats.	Barley.	Potatoes.	Families Relieved.
Oise .. .. .	sacks. 640	sacks. 361	sacks. 684	sacks. 308	2,676
Seine-et-Oise .. .. .	536	1,449	587	1,360	1,637
Seine-et-Marne .. .. .	33	98	67	198	147
Seine .. .. .	163	669	123	1,754	1,522
Outer departments .. .. .	2	9	51	6	..
Grand Total ..	1,374	2,586	1,512	3,626	5,982

The district south of Paris having been cut off from the source of relief by the Communist insurrection, the Committee were of opinion that it was impossible to distribute usefully the whole of the seed-corn allotted to the Paris district over one-half the area originally contemplated. They therefore decided, with the aid of a further grant of 3000*l.* from the Lord Mayor's Fund, to establish a fourth centre of distribution at Rouen, for the relief of the departments of the Seine Inferieure, Eure, and Calvados. To this district they sent some of the corn that had been intended for the district south of Paris, and an additional quantity specially purchased. Captain W. Delf, of Great Bentley Hall, near Colchester, took charge of this *dépôt*, and distributed the following quantities of corn and seeds sent by this Committee:—710 quarters of barley, 1567 quarters of oats, 260 tons of potatoes, 100 quarters of vetches, 4000 packages of seeds as before, 2 sacks of cabbage-seed, and 11 sacks of grasses; also a cargo sent by the Scotch Fund, consisting of 11 sacks of barley, 231 sacks of oats, and 871 sacks of potatoes. Captain Delf also received from Boulogne a small quantity of wheat and some barley which had been intended for distribution from the Paris *dépôt*; but the wheat, about 64 quarters, arriving too late to be sown, was sold for grinding.

The following are the total quantities of grain, potatoes, and small seeds sent to France last spring by the English Seed Fund Committee:—

Wheat	.. .. .	3695	Qrs.
Barley	.. .. .	3836	„
Oats	.. .. .	5387	„
Tares	.. .. .	250	„
Potatoes	.. .. .	700	Tons.
Haricot Beans	4000 half-peck bags	.. ..	(500 bushels).
Turnip Seed	4000 quarter-peck bags	.. ..	(250 bushels).
Carrot Seed	4000 two-pound packages	.. ..	(8000 lbs.)
Onion Seed	4000 quarter-pound packages	.. ..	(1000 lbs.)
Sundry Seeds,	about 500 sacks and bags.		

The system adopted by the representatives of the Fund, so as to guard as much as possible both against fraud, and against misappropriation of the grain, was resolved upon after considerable deliberation. The first duty of the representatives was to form a Local Committee consisting of landowners and other persons of influence and agricultural knowledge. The next step was to obtain from the Maires of Communes, or other qualified persons, a statement in detail, on forms supplied for the purpose, of the wants of the peasant-farmers in their Commune or Canton, specifying the names of the applicants, the acreage occupied by them, and the quantity of each kind of grain asked for. This statement was certified by the maire, the curé, or the schoolmaster, and some agriculturist of influence, generally either the President of the

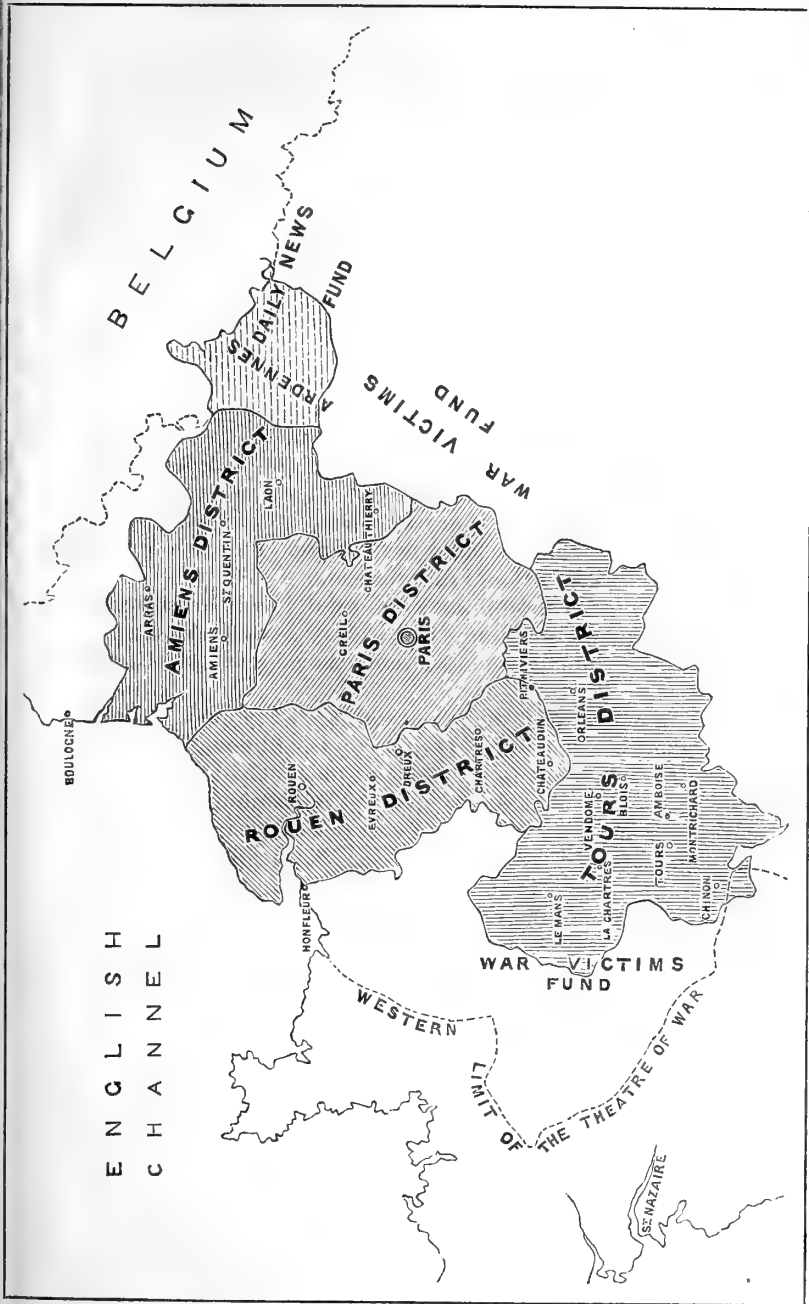

Comice Agricole, or a Member of the "Société des Agriculteurs de France." It was then examined by the representative of the Fund and the Local Committee, revised if necessary, and the quantity actually voted stated thereon by the representative. The seed was sent for by the Maire or his deputy, who signed a receipt for it; and a receipt for each portion of it was subsequently signed by the individuals whose claims had been allowed, when they received the grain. The original return, fully signed, was finally delivered to the representative of the Fund, but a duplicate was kept by the maire for future reference. In the face of these precautions it seems almost impossible that there should have been any room for misappropriation, except by the peasant-farmer himself; and it is, of course, quite possible that amongst the thousands who received seed-corn some few may have sold it, or used it for other purposes than seed. So greatly, however, was the boon esteemed, that in at least one district the landed proprietors publicly announced that they would prosecute at their own expense any person who sold or otherwise misappropriated the seed, and demand the infliction of a fine representing 20 times the value of the grain misused.

This general description may be usefully supplemented by the following quotations from Col. Cox's report, showing, as an example, how the instructions were carried out at the Amiens dépôt:—

"The mode of allotting seed which we adopted and carried out in the Département de la Somme was, although one involving a considerable amount of attention and clerical labour, on the whole by far the most satisfactory. All communes sent in to us returns containing the names of every one that required assistance, with the quantity of land under each description of cultivation, and the quantity of seed of each description applied for by each person. These returns were then carefully examined, the names of those the extent of whose property did not include them in the necessitous classes were eliminated, unless it was shown that special circumstances rendered them deserving of help; all rows of figures were added up so as to show the total extent of land for which seed was required, and the amount of each sort of seed demanded. The quantity of each sort of seed which was considered proportional to the necessities of the commune was then allotted by the representative of the Society, who signed the paper and also the order on the storekeeper for the grain.

"The mere addition of these long rows of figures occupied most of the time of a clerk, but the work could not have been performed in so just and satisfactory a manner if this had not been done.

"The returns were then sent back to each commune, on which



Liste des Personnes de la Commune de Sappignies Canton de Bapaume Depart. de Pas de Calais ayant besoin de semences  
Chaque individu n'aura droit de réclamer que 4 petits sacs de 70 litres chacun et en général les semences ne  
sont pas données excepté à ceux dont l'étendue de l'exploitation n'excède pas 10 hectares.

Bureau d'Amiens  
14, Rue St. Marc.

Noms et Prénoms	Etendue de la Propriété.	Blés de Mars.		Avoine.		Orge.		Semences de terre.		Observations.	Ces colonnes ne doivent pas être remplies qu'après la distribution des semences.				Signature du Réceptionnaire.
		Tonnages		Tonnages		Tonnages		Tonnages			Semences données.				
		de Métrics	de Sacks	de Métrics	de Sacks	de Métrics	de Sacks	de Métrics	de Sacks		de Métrics	de Sacks	de Métrics	de Sacks	
Brunel - Brunet	huit hectares cinquante	3.50	1.00	5.00	0.75	5.00	0.75	2.00	La commune de Sappignies	2.20	2.50	30	Brunel Brunet		
Brunel - Lancel	5 <sup>he</sup> 00	2.50	0.75	2.50	0.50	2.50	0.50	2.00	accusé fondation 3 jours fruit les	2.20	2.50	20	Brunel		
Buffaux - André	1 <sup>re</sup> 50	0.75	0.25	0.25	0.75				avant-propos plusieurs, composé	0.50	0.25		Buffaux		
Chicler - Caroux	2 <sup>de</sup> 50	0.50	0.15			2.00	0.25		rien enlevé de fontaine en	0.40	0.25		Chicler		
Capelle Jean P <sup>re</sup>	2 <sup>de</sup> 07	0.40	0.75			2.25	0.50		120 Caroux. Elle a été le 18/10	0.25	0.25		Capelle		
Coste J. P <sup>re</sup>	8 <sup>de</sup> 75	1.75	3.50	1.00	3.00	2.75	0.75	2.00	de très batailles, elle a composé	2.70	2.50	40	Coste		
Stuy P <sup>re</sup> G <sup>re</sup>	8 <sup>de</sup> 60	1.75	3.50	1.00	3.00	2.75	0.75	2.00	troublement, elle a été le 18/10	2.70	2.50	40	Stuy		
Domsautte G <sup>re</sup> Y <sup>re</sup> ?	2 <sup>de</sup> 00	0.45	0.50						des récoltes françaises par ailleurs	0.30	0.25		Domsautte		
Fassin Péni	1 <sup>re</sup> 60	0.26	0.50					0.26 0.50	grains plusieurs jours - sur	0.20	0.25		Fassin		
Héle Alexandre	3 <sup>de</sup> 00	0.53	1.00	0.53	1.25	0.26	0.75	0.26 1.00	16 cultures fontaine de la commune	0.40	0.25		Héle		
Héle Joseph	4 <sup>de</sup> 00	0.75	1.25	0.53	1.25	0.40	0.75		7 en son lieu de plantation. Les autres	0.50	0.25		Héle		
Héle Péni	1 <sup>re</sup> 50	0.26	0.50	0.26	0.70	0.26	0.50		nommé l'entretien de l'entretien par	0.25	0.25		Héle		
Héle Georges	1. 50	0.26	0.50						de cherant parce qu'ils manquent	0.25	0.25		Héle		
Léandre Pierre G <sup>re</sup>	1. 50	0.26	0.50					0.26 0.50	de fourrages enterrés dans	0.25	0.25		Léandre		
Léandre Pierre G <sup>re</sup>	7. 00	0.70	1.50	0.70	1.50	0.26	0.50		pour l'autre. La perte totale	0.70	2.50	40	Léandre		
Léandre Louis J <sup>re</sup>	5 <sup>de</sup> 00	1.00	2.00	0.53	1.25	0.26	0.50	0.75 2.00	occasionnée par les Russes s'il n'y	1.00	2.50	30	Léandre		
Leguette Aimé	4 <sup>de</sup> 00	0.75	1.25	0.53	1.25				à 50 000 fr - La population n'est	0.50	0.25	25	Leguette		
Mousselle, bailleur	1 <sup>re</sup> 00	0.13	0.25						que de 306 habitants.	0.12	0.25		Mousselle		
Gauthier Dési	1. 50	0.40	0.75							0.25	0.25		Gauthier		
Reuson Joseph	1. 50	0.26	0.50			0.26	0.70				0.25	30	Reuson		
Léandre Aimé	2. 50	0.26	0.50							0.25	0.25		Léandre		
Commissaire instituteur	1. 00							0.26 0.50			0.25		Commissaire		
Cuvillier Pierre G <sup>re</sup>	2 <sup>de</sup> 50	0.40	0.75							0.25	0.25		Cuvillier		
Leguette h <sup>re</sup> Aimé	5 <sup>de</sup> 00	0.13	1.00							0.40	2.50	30	Leguette		
Capelle Pierre	0. 50	0.26	0.50							0.25	0.25		Capelle		
Héle Louis J <sup>re</sup>	2 <sup>de</sup> 00	0.26	0.50							0.25	0.25		Héle		

# 219

Ces colonnes ne doivent pas être remplies  
qu'après la distribution des semences.

Noms de Finoms	Étendue de la Propriété.	Blés de Mars.		Avoine.		Orge.		Pommes de terre.		Observations.	Semences distribuées				Signature de l'acceptationnaire
		Quantité		Quantité		Quantité		Quantité			Semences		Semences		
		à l'hectare	en hectolitres	à l'hectare	en hectolitres	à l'hectare	en hectolitres	à l'hectare	en hectolitres		à l'hectare	en hectolitres	à l'hectare	en hectolitres	
P. Bienville, Tylorin	1 <sup>h</sup> 70	0,23	0,25								0,12	25			Duvella
Duffas, Delaplan	0, 13	0,13	0,25								0,12	25			Duffas
P. Bourgeois, etc.	2 <sup>h</sup> 00	0,15	0,25								0,12	25			Bourgeois
Legrand, etc.	1 <sup>h</sup> 50		30 ha												X
Yves, etc.	2 <sup>h</sup> 25														Yves
J. Bourgeois, etc.	2 <sup>h</sup> 26														X
Champion, etc.	2 <sup>h</sup> 26														X
J. M. M. M. M.	1 <sup>h</sup> 70														ensemble
J. Brunet, etc.	2 <sup>h</sup> 26											25			Brunet, etc.
J. Brunet, etc.	1 <sup>h</sup> 00														Brunet, etc.
Brunet, etc.	2 <sup>h</sup> 25														Brunet

Quantité accordée.

Blés de Mars	16 sacs
Avoine	24 sacs
Orge	1 sac
Pommes de terre	6 sacs

219

Vu et approuvé

*(Signature)*

*(Signature)*

Président de la Société Agricole

Secrétaire

Cari ou Titulaire de l'École.

Nombre de la Société Agricole.

the mayor either came or delegated some one to receive the order, and to remove the grain from the stores. On receipt of the grain it was distributed by the mayor, with the aid of his municipal council, and each recipient signed his name as an acknowledgement of the quantity given to him, the return, when thus completed, being brought back to me.

“By this means a salutary check was maintained on the mayors, who in small communes are often mere peasants, and who would naturally feel inclined to favour their friends and relations at the expense of others whose wants might be equal or greater.” (Pp. 5 and 6.)

“In allotting grain to the department of the Somme, in which I have resided during the greater part of the war, I have been guided by my knowledge of the proportion in which each commune has suffered during the invasion; for instance, those in whose immediate neighbourhood battles took place, and where houses and property have been destroyed, have naturally received the largest share of assistance, as also have those communes which, being on or near the main roads traversed by the belligerents, and in the vicinity of the usual halting places, have suffered the most from requisitions.” (P. 6.)

The annexed fac-simile reduction of one of the tableaux used will give a better idea than any description of the thorough manner in which the precautions were carried out. It also shows the prevailing size of the farms in the district, and, what will astonish many Englishmen, that almost every one of the peasant-farmers was able to sign his name.

Such having been the history, organization, and spring work of the Seed Fund, it remains to describe the result. Fortunately, it is easy to give an authentic summary under this head, because at a General Meeting of the subscribers held on the 23rd of May, the Executive Committee were authorized to send a representative to France for the purpose of obtaining information on this question. Capt. Delf, the gentleman who undertook this duty, presented an able report, from which the following extracts are made, the only preface necessary being that the general result was a complete success in every respect but one. The nursery wheat was generally a failure, owing to the circumstances stated in the following paragraphs; the April wheat, barley, oats, maize, vetches, and other fodder crops, as well as the garden-seeds, were all eminently successful.

On pp. 5 and 6 of his Report, Capt. Delf states:—

“On July 20th I drove to Meslay, which had been the scene of an engagement between the Prussians and French; very great had been the necessities of this commune, and much relief had been rendered by a liberal distribution of wheat, barley, oats,

maize, potatoes, &c. All who had been recipients spoke in the highest possible terms of the fine quality of seed sent out, and with the exception of the wheat crop, which was a failure—partly in consequence of the late period of sowing, and partly owing to the parching weather in the months of April and May—the crops were very good indeed, especially the oats and barley; the average yield of the former grown from our seed I should estimate at about 11 sacks per acre, and that of the latter about 8 sacks. When I speak of the crops as being good, I wish to be understood that I give the estimate of the cultivators themselves, and at the same time I take into consideration the unfavourable circumstances under which the seed was sown. Here I had the opportunity of comparing in two instances barley raised from English and from French seed growing side by side, and in both cases the very marked superiority of the crop produced from our seed was apparent. The maize was being cultivated as a forage crop for cows, which are very partial to it, and produce a decided increase of milk from its use; the potatoes were in every way satisfactory, and held out hope of a good return.”

In reference to the neighbourhood of Villandry, he remarks that “The autumn-sown wheat was truly wretched, a great deal of land was occupied by crops that could not possibly yield more than five bushels per acre; and, owing to the sparseness of the crop and the want of attention in cleaning the land, an overwhelming crop of weeds, embracing almost every variety, was the result. The wheat sent by the Society had, in consequence of the late period of sowing, failed to mature itself; but in one respect it had the advantage of their autumn-sown wheat, which was this,—the seed had grown very well and tillered strongly, hence the ground was well covered with a dense coat of herbage which had kept the land clean, and would yield a fair amount of forage.”

“The barley was a most refreshing sight. The seed selected was of a very fine description, and the growing crop bore evidence of its value, the near approach to maturity enabling me to form a very fair estimate of the yield. The variety was certainly the long-eared Nottingham; it was ripening off with a brilliant golden hue, and was remarkably plump, promising to yield a sample which would cause the buyers of Bass, Allsopp, and others, who are very dainty in their selections, to limit their part in this transaction solely to the matter of price. A great deal that I saw in my morning's walk carried heads in which from 28 to 36 grains could be counted. The poor peasants were very loud in their praises of the English barley, and I found that there was a general intention on their part to retain it for seed preference to the native varieties; a very gratifying proof that



the help rendered to them in a time of cruel distress was calculated to prove a lasting benefit. The average yield of the barley grown from French seed in Villandry and a few neighbouring communes I should estimate at from 4 to 6 sacks per acre, and the result of the English seed at from 7 to 9 sacks per acre. In drawing these comparisons I was very careful to ascertain that the conditions under which the seed was sown were similar, and in most cases the comparisons were drawn between crops separated only by a single furrow.

"The oats seen around Villandry were of two varieties, viz., Tartarian and potato; they were very much superior to the oats grown from the native seed, the straw being much longer, and the grain-produce decidedly larger. The gift of oats was very much esteemed, and I was told that it was the intention of the peasants to substitute the new stock for the old." (Pp. 8 and 9.)

"Leaving Château-le-Rideau in the direction of Chinon, and ascending some rising ground, we came upon a plateau of argillaceous land, where I was shown a remarkable contrast between several pieces of barley grown from the Society's seed compared with others which had been produced by the native seed. The difference was so distinctly in favour of our own that the most untutored eye would at once detect it. Here there was nothing to wish for; our seed was evidently that of the Nottingham variety; similar to that I had seen in the neighbourhood of Villandry, and like that was bright in colour, plump in condition, and long in the ear. The average produce of the English barley seen in this walk I should estimate at from 7 to 10 sacks per acre. I was also shown much maize growing from our seed, which had had great care bestowed upon it, in common with most of the forage crops; here also was the promise of great abundance of food for the cows." (Pp. 10 and 11.)

"At Monnaie, the Maire, M. Tiphaine, was able to show us some very interesting results, by reason of the active part he had taken in the distribution of our seed. On several pieces of land bearing barley, oats, maize, and potatoes, grown from this Society's seed, the produce was very satisfactory, especially some barley which had had a little extra manure; this crop was of very fine quality, and in quantity I should estimate it at 10 sacks per acre. I also saw some very good oats of the Tartarian variety, which were superior to any of the oats of the country; one piece which I inspected had been sown with a mixture of Tartarian and French oats, and afforded a most convincing proof of the place that the former will take with the peasant-farmer, the English oats being much longer and stronger in the straw, and, what is more to the purpose, the grain was in like measure. The red Scotch potatoes were highly prized, as they

were far ahead of the generality of those raised from native seed." (Pp. 12, 13.)

With reference to the district in which he had himself distributed the seed, Captain Delf writes as follows:—"In the Seine Inférieure I inspected many communes in the cantons Elbeuf, Boos, Maromme, Pavilly, Clères, Buchy, Neuchâtel, Forges, and others: everywhere I was met with smiles from those who had received help, and every expression of gratitude was poured out by the peasantry, who spoke in the highest terms of the results from the grain, potatoes, &c., sent from the English Society; all had succeeded well, the oats were magnificent, the barley was of a quality they are quite unaccustomed to, vetches were good, and the potatoes were promising a large return. The latter crop had hitherto escaped the disease, which had shown itself about a fortnight in those grown from the seed of the country. At Grand Couronne I saw a striking instance of the exemption of the Scotch potatoes from any symptom of disease, while those growing from the native tubers, and the sets immediately adjacent, were badly attacked. The benefit accruing from this Society to the agriculture of France generally will be very great, inasmuch as the larger farmers are applying to the peasants for a stock of seed of English variety for future sowings: thus the peasants will make an extra price of this year's harvest produce, and at the same time benefit their neighbours, the large occupiers." (Pp. 29, 30.)

The foregoing quotations are extracted from Captain Delf's Report, as being fairly descriptive of the results of the operation of the Seed Fund in some of the departments in which the seed was distributed. But Captain Delf states that similar accounts might be given as to the result in every commune which he visited during a tour that occupied nearly two months. It is, however, unnecessary here, as it was in that Report, to give statements that are mere repetitions of one another.

With regard to the failure of the Nursery wheat, I took great pains last autumn to ascertain the facts with a view to their explanation, and more especially made notes of a few instances of a more or less satisfactory nature, which I will quote from my Report to the Committee:—

"In the department of the Somme two communes in the canton of Combles have reported that the results of our spring wheat have been very satisfactory; while the commune of Moislains, canton of Péronne, adds that the crop was superior to that yielded by the seed the farmers had been able to buy. Another commune in the canton of Péronne reports that the *bearded wheat had yielded well*, while the other kind had given nothing but straw. Two communes in the canton of Roisel have

forwarded reports of a parallel nature, Marquaix stating that all the crops (wheat included) were very good, and Epehey giving a list of thirty-one persons who had had a good crop of wheat from our seed, and of ten others whose crop was bad or nil, the Mayor adding a note to the effect that there were two kinds of wheat, because one-fourth had completely failed. This is a very interesting case, because of the 41 recipients, 39 had a uniform quantity of 25 litres each (about two-thirds of a bushel), showing that they were all small peasant-farmers. Curiously enough, also, of the remaining persons, each of whom received 50 litres, one had a good crop and the other none at all. One other illustration, furnished by the commune of Montonvillers, in the canton of Villers Bocage, will be sufficient for the department of the Somme. In this commune there were six recipients of our wheat; of whom five got nothing but straw, while the sixth, who received 90 litres of seed, namely, one 2-bushel bag and part of another, obtained a crop at the rate of 14 bushels per acre. The crop was probably produced by the 2 bushels of seed, the remainder not contributing to it; and the Mayor remarks that the seed given to this person was probably of a different kind from the rest, and that it was a bearded wheat. The other kind produced nothing but a kind of grass, which was at most fit only to be pastured by cattle, as it developed no flower-stalk. He also adds, that those who have taken part in the distribution think that either the nature of the soil or the climate is unfavourable to this description of wheat, and he begs us to believe that the peasantry are none the less grateful for the benefits which we have conferred upon them.

“The foregoing reports are, it will be observed, from the department in which the operations of the fund were commenced, and where, if anywhere, the wheat should have been sown in good time. As much stress has been laid on the theory that the wheat was sown too late, I took great pains to investigate personally, in company with Mr. Pitman, a case in which some of our wheat yielded what, under the circumstances, appears a fair crop, after having been sown as late as the middle of April; thus proving to my mind that the failure of our wheat in the Somme was not due to the lateness of the period of sowing, which was at least a month earlier than in the case I am about to describe.

“The commune of Nonville is situated nearly due south of Paris, and about six miles east of Nemours, in the department of the Seine-et-Marne. It is one of the three communes in this department which received spring corn from our Paris Committee, and it was probably one of the latest distributions of wheat made by any of the representatives of the Fund, the date of the Mayor's receipt being April 10th.

“The soil of Nonville is a more or less sandy loam, lying on the

narrow outcrop of the Fontainebleau sands and its associated strata. According to its strength, which is somewhat variable, it would probably be worth from 25 to 30 shillings an acre, judged from an English standpoint, if it were in fair condition, which, by the way, is not the case. The course of the cropping is simply (1) wheat or rye, (2) barley or oats, (3) bare fallow. It is unnecessary to enter further into details of cultivation, because the accessories of such a system are tolerably well known. It is sufficient to state that this commune received on the 10th of April 3062 litres (about 11 qrs.) of spring wheat, and 2937 litres (about 10½ qrs.) of barley. The latter yielded what was considered a very good crop; but of the former, 1049 litres produced an excellent result, while the remaining 2012 litres produced nothing at all. The Mayor informed us that there were evidently two kinds of wheat, and his descriptions, as well as those of the cultivators, enabled us to recognise the April and the Nursery varieties. The bearded or April wheat had produced a crop varying by estimate from 15 to 20 bushels per acre, as much as 24 being mentioned in one instance, which our informant stated was the best crop of wheat he had ever seen. It is worthy of remark that the two kinds of wheat were sown both side by side, and mixed together; after barley, after wheat, and after bare fallow, but always with the same result. As the Mayor remarks in a letter:—*‘Nous avons pu voir dans la même pièce de terre, un blé de printemps magnifique, et à côté, un blé n'épiant pas et ayant toutes les apparences d'un blé d'hiver.’*” (Pp. 11-13.)

“It is thus evident that the Nursery wheat failed, while the April wheat succeeded; and it is worthy of remark that the latter has considerable affinity with the ‘Blé de Mars’ of the country.

“On this point Mr. Patrick Sheriff, who is well known as an authority in such matters, has expressed the opinion that there are two distinct varieties of Nursery wheat, one being a winter and the other a spring kind. It may be that our seed was of the former variety, or, at any rate, that it was the produce of winter-sown Nursery wheat, which had thus got the habit of growth of a winter plant, namely, a period of growth, followed by a period of rest, and again succeeded by a period of growth, during which the flower and grain are successively formed.\* That this was the habit of our wheat is shown by the following translation of the

---

\* “Since writing this Report I have been able to consult Mr. Darwin's work, ‘The Variation of Animals and Plants under Domestication,’ and have found the following striking confirmation of this opinion:—“Wheat quickly assumes new habits of life. The summer and winter kinds were classed by Linnæus as distinct species; but M. Monnier has proved that the difference between them is only temporary. He sowed winter wheat in spring, and out of one hundred plants

report of the commune of Warloy-Baillon, in the canton of Corbie, department of the Somme:—"The wheat remained a long time without growing visibly, resting in braird (*en herbe*) close to the ground exactly like rye-grass. Its growth commenced towards the end of June, the stalk grew rapidly, and the head made its appearance in the best condition. When ripe, every one was surprised to find that the ear was barren. Whether that was caused by excessive heat, or by very cold nights, we must leave to be decided by more competent men.'" (Pp. 13, 14.)

#### AUTUMN DISTRIBUTION.

At the close of the distribution of spring corn and seeds, the Committee had in hand a balance of about 2000*l.*, consisting of subscriptions which had been received too late to be usefully expended that season. Still later they received, through M. Drouyn de Lhuys, a Swedish Fund amounting to 6300*l.*, and a Limbourg Subscription of about 390*l.*; finally, some large payments for railway carriage in France were refunded partly by the French Government and partly by the railway companies. Thus, at the approach of the autumn seed-time, the Committee possessed nearly 11,000*l.* for distribution; and after consultation with M. Drouyn de Lhuys, through whom the greater portion of it had reached their hands, they resolved to expend it in the purchase of English autumn wheat, to be distributed in the first instance to those who had received spring wheat which did not produce a

---

four alone produced ripe seeds; these were sown and resown, and in three years plants were reared which ripened all their seed. Conversely, nearly all the plants raised from summer wheat, which was sown in autumn, perished from frost; but a few were saved and produced seed, and in three years this summer variety was converted into a winter variety" (vol. i. p. 315). Mr. Darwin also quotes M. Edwards and Colin 'Annal. des Sciences Naturelles,' 2nd Series, Bot. tom. v. p. 22) to show that "a kind of wheat which in England may be used indifferently either as a winter or summer variety, when sown under the warmer climate of Grignon, in France, behaved exactly as if it had been a true winter wheat" (vol. ii. p. 307). As Mr. Darwin does not state whether the seed sown in France was the produce of winter-sown or spring-sown English wheat, and as this case is exactly parallel to our own, I referred to the original paper, hoping to find that the authors had ascertained this circumstance before making the experiment. Unfortunately, however, it appears that the experiment was not made by them, but by M. Bella, of Grignon, and no indication is given that any inquiry had been made as to the pedigree of the seed which he used. The fact alone therefore remains, that a similar description of wheat to the Nursery variety, if not the same, was sown in France many years ago, with the same result as that attending the use of Nursery wheat last spring. It may be added, however, that M. Bella's case was one of deliberate experiment, unattended by any of the complications and difficulties which were last spring encountered by the French Peasant-Farmers' Seed Fund, and by French seed-merchants. It therefore strengthens the conviction in my mind that the failure of the Nursery wheat was not the result of late sowing, or of an untoward season, or of want of preparation of the land, but was owing to a constitutional peculiarity in this variety of seed."

crop, in the proportion of one bushel for every two which they had previously received. The balance left was chiefly intended for the region immediately south of Paris, which had obtained very little assistance in the spring, in consequence of its having been cut off from communication with our *dépôt* by the second siege. In other respects, the Committee resolved to adhere as closely as possible to the rules laid down for the guidance of their representatives during the spring distribution.

The principles of distribution having been agreed upon, the Mark Lane Committee, through Mr. Pavy, purchased 2780 quarters of red wheat, and Mr. Odams again undertook the shipping department. This distribution, being conducted in a time of peace, did not require so numerous a staff of English representatives in France as the spring distribution, which was conducted under the double difficulty created by civil warfare and a hostile occupation of the country. In addition, most of the previous representatives of the Fund were no longer resident in France, and a new agency was therefore unavoidable in those cases. Fortunately, however, Colonel Elphinstone was again able to undertake the distribution in the district of La Beauce, and the Committee therefore forwarded him 800 quarters of wheat for the purpose of giving half-quantities to those who had been disappointed of a wheat crop from our spring seed. The districts of the North of France and Paris, including the departments of the Somme, Aisne, Pas-de-Calais, Oise, Seine, Seine-et-Oise, and Seine-et-Marne, were consolidated into one, and placed under my own charge, and I was fortunately able to secure the assistance of Mr. C. B. Pitman, who had been a member of the Paris Committee in the spring. The seed corn for those departments, amounting to about 1550 quarters, was sent *via* Boulogne, at which port M. Vaillant displayed the same energy in landing and forwarding the corn as he had previously exhibited. The remainder of the wheat was sent to the departments of the Eure, Eure et Loir, and Seine Inférieure through Captain Delf.

It is unnecessary to enter into further detail in reference to this distribution, as its method differed in no essential particular from that which has already been fully described. In some districts, however, there existed, not unnaturally, a prejudice against English wheat, in consequence of the spring variety having too generally failed; a letter was therefore in the first instance addressed to the mayor of every commune which had received spring wheat, stating the intention of the Committee to distribute half the quantity of wheat previously given to each of the peasant-farmers who had failed to obtain a crop from their seed, and asking whether those in his commune were desirous

of participating in this new distribution. On the receipt of an affirmative answer, the same routine was gone through as was found to work so well before, and to give the best guarantee possible that the seed was applied to the purpose for which it was intended.

The following summary of the distribution in the North of France shows that after giving half-quantities in the Somme, Aisne, Pas-de-Calais, and Oise, there remained a large quantity to distribute amongst the peasant-farmers in the Seine, Seine-et-Oise, and Seine-et-Marne, most of whom had been prevented from receiving any assistance in the spring.

	Communes.	Sacks.	Persons.
Somme .. .. .	168	662½	3708
Aisne .. .. .	100	235	1272
Pas-de-Calais .. .. .	38	130	787
Oise .. .. .	54	280	1559
Seine-et-Oise .. .. .	49	740½	1271
Seine .. .. .	38	531	804
Seine-et-Marne .. .. .	37	533½	915
Incomplete total .. .. .	484	3112½	10,316

In the southern district Colonel Elphinstone distributed 455 sacks in the department of the Indre-et-Loire, 460 in the Loir-et-Cher, 370 in the Loiret, 300 in the Eure-et-Loire, and 15 in the Sarthe. The total quantity of 1600 sacks was distributed in 371 communes, or an average of  $4\frac{1}{3}$  sacks per commune; and as each individual received on an average two decalitres (rather more than 2 pecks), Col. Elphinstone calculates that the donation must have been shared by 12,000 cultivators, representing so many households or families.

The result of the autumn distribution is soon told. After a tour of inspection, made just before harvest, in the course of which I examined the wheat crops in several communes in the departments of the Somme, Seine-et-Oise, Seine-et-Marne, and Loiret, I came to the conclusion that the yield of the English wheat would be at least 25 per cent. more than that of the native seed grown in the same soil and under the same circumstances.

It was, in fact, easy to identify the English wheat at a considerable distance off, by its deeper colour, its greater height, and its general appearance of bulk and solidity. The French cultivators told me in every district that there was not a laid patch to be found in their commune, and also that there was no appearance of smut or bunt, whereas a large acreage of the French wheat was fearfully battered, and abounded in "noir." Everywhere the intention to preserve the crop for seed was expressed as a settled course of action. In many cases I was assured that it had been bespoken at high prices by the larger farmers in the district; and

already, as if in confirmation of this favourable result, I have been asked to assist French farmers in purchasing in England the same description of seed-wheat as that which we distributed last autumn.

The crop yielded by our autumn wheat being destined for seed purposes, I was very desirous of seeing something of the result of sowing the produce of our spring-seed. I found no difficulty in discovering large breadths of land under oats and barley which were the produce of our spring distribution, the yield and quality being uniformly of a most satisfactory nature, particularly in the case of the barley. I also determined, if possible, to trace our spring wheat to a second generation, and for this purpose selected Nonville, a commune upon which I have reported at some length in reference to the spring distribution (see pp. 343, 344). It was very gratifying to find that the produce of our April wheat had been carefully saved for seed, and that this year much of the wheat land in the commune had been sown with it. Some of the patches which had been well treated were estimated by the Maire to yield about 32 bushels per acre, and this he considered a most extraordinary crop for the locality and soil. Other patches, which had been wheat last year also, or which had been otherwise less cared for, would not yield more, probably, than from 20 to 28 bushels; but in every case the English April wheat was much superior to the native Blé de Mars, treated in the same manner.

The autumn wheat distributed in this and other communes was of the Spalding variety; and examples were shown me of the standing crop from seed sown after both bare fallow, mangolds, potatoes, and wheat last year. The results were, in descending order, as above named; but in all cases the crops were far superior to those from native seed sown under similar circumstances. The Maires informed me that the crop of English wheat would be preserved entirely for seed; and it was believed that the whole of it had been bespoken for that purpose by farmers in the neighbourhood. I may add that this evidence was corroborated in every particular by many other authorities in different parts of France.

After the operations which I have described, a balance accrued by further refunds and the sale of sacks, amounting to about 1100*l.* This sum has since been distributed by Mr. Furley and Mr. Pitman, in the Ardennes and other departments where the peasant-farmers had suffered most from the destruction of their houses and implements. We had previously distributed in the Ardennes seed-corn to the value of 500*l.* through Mr. Bullock, of the *Daily News* Fund, in conjunction with the Belgian Seed Fund Committee, to whom the care of that region had been left by mutual consent.



## THE WAR VICTIMS' FUND.

Although the object of this paper is to describe the operations of the French Peasant-Farmers' Seed Fund, it would be incomplete without some reference to the War Victims' Fund,—a powerful organization formed by the Society of Friends. With their distributions of food, clothing, tools, and money, we have nothing to do in this Journal, although they represent an enormous sum of money, and have done an incalculable amount of good. Their distributions in seed-corn and potatoes, however, alone represent a value of more than 30,000*l.*; and as they were made in districts adjoining those in which the operations of the Seed Fund were carried on, and in conjunction with our representatives, we may regard them as having fulfilled the same function as ourselves in districts where our means would not allow us to work. The following summary of their distribution in seed-corn and potatoes is taken from the General Report of the Committee:—

*Metz District.*—“As the winter wore on, the uncultivated condition of the land, due to the scarcity of horses, the impossibility of obtaining seed-corn, and the depressed condition of the people claimed the serious attention of the Committee, and a special deputation went out to Metz to inquire into the suitability of the land for steam cultivation. Under their advice a complete double set of Fowler's Steam Ploughs and Cultivators was sent out, and has been doing good work in bringing into cultivation the larger plots of land, thus finding employment for many, and setting free the few horses that remained to work the smaller plots. Very large consignments of seed-corn, suitable to the district, and of seed-potatoes were also made: and, after much labour and anxious deliberation, were distributed amongst the needy proprietors and cultivators in all the villages round Metz, in time for the spring sowing. The total quantity thus sent was about 28,000 bushels of barley, oats, and other seeds, and about 970 tons of potatoes, costing about 10,250*l.*, calculated to sow about 11,000 acres.”

*Loire District.*—“Acting in concert with the delegates of the French Peasant-Farmers' Seed Fund Committee, of which Lord Vernon is president, preliminary arrangements were made for the distribution, through local committees appointed in the chief towns of the devastated districts, of oats, barley, and potatoes, for spring sowing. The season was so far advanced that the utmost exertions were needful in despatching and distributing in time for this year's crop. Fourteen cargoes, amounting to about 3000 tons, were purchased and despatched by various steamers

from London, Aberdeen, Arbroath, Glasgow, Newry, &c., to the French ports of Nantes, St. Nazaire and St. Malo. Arthur Albright, Wilson Sturge, James Long, and S. J. Capper were despatched as delegates to arrange for the reception and forwarding to the interior of the various cargoes as they arrived; and from the latter part of the third month to the present time, A. Albright and one or other of his colleagues have been most energetically engaged in the work of transit and distribution, and in the purchase of various seeds in addition, which it was found they could obtain advantageously in France.

“It seems certain, that but for the supplies thus distributed by our delegates and those of the French Peasant-Farmers' Seed Fund, large districts in the Valley of the Loire would have remained unsown, and the destitution in the coming season would have been fearful. Everywhere was the most lively gratitude expressed for the seasonable aid afforded, and we may trust that the impression of goodwill between those afflicted people and their English helpers will not soon be effaced.

“The cost of seed and seed-potatoes sent by our Committee into this district has been about 22,000*l.*, and the quantity is calculated to sow about 25,000 acres—being about 48,000 bushels of oats, barley, and other seeds, and about 1950 tons of potatoes.”

#### GENERAL REMARKS.

In the foregoing pages I have endeavoured to give an intelligible statement of the main work of the Seed Fund and its results. In one word, its operations have been highly appreciated in France, and the results have been eminently satisfactory. The assistance given by the French Government was no doubt an accurate interpretation of the national feeling, both when it was resolved to admit our seed-corn free of duty, and afterwards when our Exchequer was reimbursed with the sums which had been paid for railway carriage.

The economical result of the spring distribution has been well summed up by Capt. Delf in the following paragraph, which I extract from his Report:—

“Of the immense benefit conferred by the French Peasant-Farmers' Seed Fund upon many thousands of families in the worst ravaged districts of France there can be no doubt, as several thousands of acres have borne abundant crops of oats, barley, potatoes, vetches, maize, &c., which would otherwise have remained untilled. The gratitude of the peasantry is unbounded, and not a little has been effected by this Society in establishing a bond of union and confidence between the agriculturists of this country and those of France. A great economical, bene-

ficial, and lasting result will accrue to the agriculture of France from the distribution of a large variety of new seeds in the country. The value attached to the British varieties is indicated by the fact that the larger proprietors are already seeking to obtain, for future seed-times, their stock from the peasants who have been supplied by this Society; this advantage is recognised by the various agricultural societies of France." (P. 36.)

The result of the autumn distribution has turned out even more satisfactorily, for both the political and the meteorological conditions of the season have combined to give the seed sent by the foreigner a better opportunity of finding a home in the soil of France.

From a purely agricultural point of view, the remarkable superiority of the crops grown from English seed,—testified not only by other observers than myself, but endorsed by the anxiety of French farmers to secure the crop for seed purposes,—must be highly gratifying to every one who has taken an interest in the Seed Fund either as a contributor or an administrator. The distinctive feature of the Seed Fund was its reproductive character. It helped those who would help themselves, not only to the amount actually given, but with the addition of a large usury. It was essentially a work of peace, and though necessarily coming after the horrors of war, it had a wonderful influence in promoting goodwill amongst men. Nearly every civilized nation followed the example set by England, and the peasantry of France have thus experienced the sympathy of the United States, Russia, Sweden, Denmark, Holland, Belgium, Italy, Switzerland and Austria. Ancient friends and ancient foes alike joined in responding to the call of humanity.

During the distribution of wheat last autumn in the northern departments of France, M. Drouyn de Lhuys, the President of the 'Société des Agriculteurs de France,' and one of the Honorary Members of this Society, placed at the disposal of the Seed Fund the offices and staff of his influential Society. He observed and studied our work; he was our guide, philosopher, and friend; and I therefore feel that I cannot conclude this Report better than by quoting from his speech, made at a general meeting of the 'Société des Agriculteurs' about three months afterwards. He thus summarizes the history of the English seed funds:—

"First of all I shall cite England: her vicinity, her numerous connections with us, her liberal and intelligent practice of organized relief, all mark her place in the front rank. Two great societies formed in London undertook the direction of this movement [the collection of subscriptions for Seed Funds] which immediately developed itself in the three kingdoms. Numerous meetings resounded with the warmest expressions, and these

found an echo in the whole English press. How much do I regret, gentlemen, that I cannot here describe in all their details the many ingenious contrivances and persevering efforts, of which I have been either the witness or the confidant. However, the subscriptions which flowed in from all parts bore evidence of the opulence, and at the same time of the munificence, of that wealthy country.

“What was to become of these abundant resources? It was necessary to make an equitable distribution, and it therefore required devotion to complete the work of liberality. Delegates offered their services to distribute relief to our cultivators in their distress, even from the midst of our ruined villages. Courageous as soldiers, zealous as missionaries, exact as accountants, on their return they prepared with marvellous accuracy the balance-sheet of these novel commercial operations, which consisted in giving everything and receiving nothing.”

---

XVI.—*Sanitary Police and the Cattle-Plague.* By M. BOULEY.

[Translated from the ‘Comptes rendus hebdomadaires des Séances de l’Académie des Sciences,’ vol. lxxiv., No. 18, April 29, 1872, pp. 1154-1165.—H. M. J.]

AN international Sanitary Conference was held at Vienna on the 16th March last, at the suggestion of the Austro-Hungarian Government, to propose a code of regulations for a uniform sanitary police. By adopting uniform measures both for preventing the introduction of cattle-plague, as well as for arresting its propagation, there need be no interruption of the ordinary commercial relations between the signatories of the Convention, even if, notwithstanding the preventive measures adopted, the cattle-plague were introduced into one district or another of the different countries.

Eleven States were represented at the Conference by twenty-six delegates, namely, Germany, Austro-Hungary, Belgium, France, Great Britain, Italy, the Roumanian Principalities, Russia, Servia, Switzerland, and Turkey. Of the delegates, fifteen belonged to the veterinary profession, and eleven were administrative functionaries attached to the sanitary service of their respective countries, and well qualified to pronounce an opinion on the propositions which required to be submitted to their judgment.

The questions on which the Conference had been summoned to deliberate were no fewer than sixty-five in number, and several others were added at the request of the representatives themselves. One remarkable circumstance deserves to be mentioned

at the outset, as it differs completely from the ordinary rule in such cases, namely, that, notwithstanding the large number of members of the Conference, and of the questions to be considered, the decisions formulated in their 'Report on the Principles which should serve as the Basis of International Regulations against the Cattle-Plague' were adopted unanimously, with the exception of two cases of secondary importance, on which the agreement was not so complete.

This perfect accord, which is by no means customary in matters relating to medical science, is a consequence of the fact that there now exists no divergence of opinion as to the foreign nature of the cattle-plague in reference to Central and Western Europe, nor as to the mode in which it is propagated. We are now thoroughly convinced that outside the Russian empire it is never developed spontaneously, no matter what may be the breed of cattle, not excepting even that of the Steppes. Consequently, whenever cattle-plague appears elsewhere, it is because it has been imported by some means or another. We also know equally well that, when it remains for a longer or shorter time in a country that it has invaded, it is kept up solely by means of contagion, that it cannot be perpetuated otherwise, and that it becomes extinct when it can no longer be communicated to other animals. It is, therefore, necessary to repeat, contrary to the opinion of some physicians, that the cattle-plague cannot become an indigenous malady in our country, under the influence of what is somewhat obscurely termed an epidemic nature. A hundred and twenty years ago it persisted in England for thirteen years consecutively, because it was not known how to get rid of it; but the phantom of epidemicity is not slow to vanish when it is decided to attack the contagion and to annul its effects.

The same fact was reproduced in the same country in the year 1866, and in a manner still more flagrant. When, in that year, the cattle-plague was imported through the channels of commerce, people persisted in ignoring its origin, and in considering it an indigenous disease developed by the exceptional heat of the season. Under the impression of this false idea they refused, for three long months, to apply the sanitary measures, the certain efficacy of which had been attested by the experience of the Continent. Thus England and Scotland suffered immense losses. But when, finally, the error was recognised, and Parliament had passed a Bill which empowered the English authorities to slaughter, in the cause of the public interest, animals which could convey the contagion, or enlarge the focus of the disease, then—and this is a thing apparently very remarkable, and by no means common in the annals of medical science—the epizootic disease, which was in its full destructive activity, was not slow

in disappearing, as if it were at the express command of the Government.

Contagion is thus the exclusive cause of the importation, the propagation, and the greater or less permanence of the cattle-plague in Western and Central Europe.

From this conclusion, so certain and so incontestable, proceeded all the sanitary measures which the International Conference decided upon, and the adoption of which they proposed to the governments of all the countries that are naturally exempt from the cattle-plague, and which suffer from it only by accident.

But if it is certain that this disease never develops itself spontaneously beyond the frontiers of the Russian empire, ought all the provinces of that empire to be equally suspected, and subject to the same interdiction? This is a question which it would have been very important to solve in the interests of commerce, but the elements necessary to the solution of it were not in the possession of the Conference. It is presumable, from the facts that the representatives of Russia made known, that in the western provinces of the empire, the cattle-plague is produced only by contagion, as in other parts of Europe; and that it is in the Asiatic territories that the conditions for its spontaneous development are found; but this is merely a presumption. It is, moreover, certain that the movement of beasts from the Ural Mountains towards the western frontiers of the empire too commonly disseminate the germs of the contagion in the country that they traverse. Russia has, therefore, been, until the establishment of new laws, necessarily left out of the Sanitary Convention which it was desired to establish; and that country should not be allowed to export its cattle except under certain more or less efficacious guarantees, of which I shall speak presently.

The danger of the cattle-plague is an incessant menace to Europe, as Russia has not yet attempted to defend its western provinces from its ravages. Could it not be neutralized by a general inoculation, rendered compulsory through the whole region of the Steppes? But the Steppes are of immense extent, and they are stocked with herds that may well be termed innumerable. Under such conditions is inoculation really practicable? At first sight it would appear that this question can be answered only in the negative. However, the objection as to its impossibility falls to the ground in face of the fact that the majority of the male beasts of the Steppes are oxen, and that, consequently, each of them has individually passed through the hands of the castrator. If castration is possible, then inoculation is equally so. But does its practice yield results of real economical advantage? On this point the opinions of the mem-

bers of the veterinary profession in Russia continue to be divided, for while some still advocate it, others strongly disapprove of it; and after long and costly experiments the Russian Government has renounced it. The results of these experiments give a mean mortality of 13 per cent., even amongst the herds of the Steppes, and this mortality is sometimes increased to 50 per cent., as was the case in 1860 and 1863 at Orenbourg and Khersoa. The International Conference has, therefore, enunciated the opinion that, in the country where the cattle-plague is endemic, there is nothing to authorize inoculation being prescribed as a measure which has been proved to possess real economic advantages.

As to the application of this so-called preventive method to the cattle of Central and Western Europe, the Conference has pronounced the opinion that it must be absolutely repudiated, because it would be too fertile in disasters. In fact, an abstract of the documents relating to the inoculations that have been practised in Central and Western Europe during 120 years gives a mean mortality of 18 to 19 per cent. This would cause at the outset a deliberate loss of 1,900,000 head of cattle in France alone, taking its bovine population to be about 10 millions.\* But the cattle-plague itself, even under conditions so favourable to its spread as those under which it recently invaded our territory, and with means so insufficient to oppose the principle of its propagation, did not cause a loss of more than 35,000 animals, dead and slaughtered. A comparison of these figures will prevent the necessity of any long commentary; as they give of themselves the measure of the practical value of inoculation applied as a preventive measure out of Russia.

It being acknowledged that Russian cattle are more or less certain to contract the plague—either by the fatality of its origin, or, more likely, over a great extent of territory, by the fatality of contagion, to which it is difficult to oppose an efficacious barrier in the actual economic condition of the country,—it was not possible† to permit the free exportation of Russian beasts. It was, however, discussed by the Conference whether it is necessary to interdict absolutely this exportation, and even this question was answered in the affirmative by the delegates of Germany, the frontiers of which are closed to Russian cattle. In Germany, this regulation is practicable in consequence of the Custom-house service, and the distinctive characters of the Steppe cattle from those of the native races of the German provinces which are adjacent to the Russian frontier. But if, under such con-

\* The number of cattle of all ages in France, according to the statistics of 1866, was 12,733,188.

† These and some other statements should be read with the qualification "in the opinion of the Conference," as distinguished from the practice of the Governments.—EDIT.

ditions, it is possible to prevent the importation of Russian cattle into Germany, this is not the case with the Austro-Hungarian empire, the frontiers of which, measuring more than 120 leagues, are difficult to close against smugglers, and the Steppes of which are characterized by cattle of the same race as the Steppes of Russia. Moreover, the Russian cattle furnish a considerable number of those required on the markets of the large towns, and for fattening in the great distilleries of Galicia. Vienna alone consumes more than 80,000 head per annum. In this state of affairs, the Conference was of opinion that it was not possible to close the frontiers of Austria against the importation of cattle from Russia; but that these beasts must not enter without restraint, and that it is necessary to continue to submit them, as heretofore, to a quarantine of ten days before they are allowed to continue their route towards the localities for which they are destined.

I abstain from entering here into any details of the measures which have been proposed with a view to render these quarantines as efficacious as possible, and to submit the imported animals to a rigorous inspection, whether their immediate destination be the slaughter-house or the feeding-byre attached to a distillery. Doubtless these measures cannot give any certain guarantee against the cattle-plague, but they must certainly diminish the chances in favour of it, because it is more advantageous for Austria to permit the importation of Russian cattle than to prevent it.

Having once resolved the important question of the commercial relations of Russia with the adjacent countries, the Conference endeavoured to establish the principles which ought to serve as a basis of uniform regulations for all countries in which the cattle-plague cannot be introduced, propagated, or maintained otherwise than by contagion.

Thus if, in countries where the cattle-plague is only an accident which can be rendered as transient as possible, the guarantee is given by the respective governments that they will adopt against it measures everywhere identical, and the certain efficacy of which, when they are rigorously and scrupulously applied experience has proved, there will no longer exist any reason for the interruption of commercial relations between those countries even when the presence of the plague has been detected in one or more of them.

Now, what are the measures, the application of which in a uniform manner can, from the commercial point of view, give this guarantee of impunity to the countries in which the cattle-plague has made an accidental invasion, and has appeared in isolated localities?

The following are those which are most essential:—

Immediate slaughter, under rules as to indemnity, of all



animals attacked by the plague, and of those suspected in consequence of the influences to which they have been exposed.

Burial of the carcasses of all plague-stricken animals, so that no portion can be used for any purpose whatever.

Utilization of the meat of animals killed on suspicion to be allowed under special conditions rigorously determined.

Destruction of the germs of contagion wherever they can be found: in cattle-sheds, manure-heaps, forage, and harness; on the roads, fields, waggons, railway-trucks, &c.; in fact, everywhere and upon everything that can have been exposed to the influence of contagion.

Isolation, as complete as possible, of the places in which the plague has been discovered, in such a manner that no animal susceptible of carrying the contagion can find an exit, and that none can enter capable of receiving it.

This isolation must be prescribed and practised on farms, in localities, parishes, and, in fact, in districts of greater or less extent according to the spread of the plague.

The establishment, round the localities the isolation of which has been prescribed, and which have been declared *infected*, of a zone in which the movement of ruminants is prohibited, as well as the trade in and the transit of everything that may possibly serve as a vehicle for contagion, whether fodder, manure, and animal products and refuse of every kind.

The suspension of fairs and cattle-markets in a certain region round the centres of infection. Enumeration of all the ruminants in the infected locality and the suspected zone, so that the local authority may have a guarantee that animals are not removed clandestinely from the places which they properly occupy.

As soon as a case of cattle-plague has been officially proved in a locality, the immediate declaration of every case of any disease to which ruminants are liable to become compulsory on the owners and keepers of those animals.

After the disappearance of the cattle-plague from a locality, and after the application of disinfecting measures, very careful precautions to be prescribed in reference to the process of restocking the fields and cattle-sheds, as well as in re-establishing free movement of cattle, and the commercial transactions of which it is the object.

To these measures, which are for the most part of ancient date, and the efficacy of which, when carried out in their entirety, has been proved by the experience of all ages and all countries, the Conference has added another. This regulation is entirely new and highly important, both from the point of view of commerce and as a sanitary precaution. It consists in the obligation

of every State in which the cattle-plague may manifest itself, to announce immediately, by telegraph, the appearance of the disease, first of all to the Governments of the adjoining countries, and afterwards to those of the States which have expressed their desire to be informed of such outbreaks.

Where the locality infected by the cattle-plague is less than 75 kilomètres (45 miles) from the frontier, the authorities of the district to which the locality belongs will have the responsibility of announcing by telegraph the appearance of the disease to the authorities of the adjoining countries.

A minute inquiry will be made as to the channels of introduction and propagation of the disease, and the result of this inquiry will, with the shortest possible delay, be conveyed to the authorities of the countries which seem to be menaced by an invasion of the plague.

Each country where the cattle-plague is actually raging will be required to publish in its official journal, a weekly statement of the condition of the disease, the measures adopted to restrict its propagation, the successive modifications which circumstances have required in them, and finally the day when they will cease to be in operation.

This statement will be sent to the editors of the official journals of the States which desire to receive it.

These sanitary measures will be productive of the greatest advantages for all countries if they are scrupulously carried out wherever the plague shows itself, because in that case every one will be on his guard against it, viz.: The authorities of the countries the most immediately menaced, in adopting without delay the preventive measures which are recommended in such cases; and the commercial world in abstaining from dealing with the infected localities or districts.

The first idea of these excellent sanitary measures, proposed to the Conference by one of the delegates of Germany, belongs to M. Zundel, an able and unassuming veterinary surgeon of Mulhouse, who published it in the 'Recueil de Médecine vétérinaire.' It is both a duty and a pleasure to give him credit for it here.

The International Conference has not desired to institute a new sanitary regime, for the purpose of preventing the invasion and impeding the propagation of the cattle-plague; but to obtain the adoption of an identical code of rules by all the countries which have combined for this object. The efficacy of these rules is proved by the beneficial results which they have always given, wherever they have been rigorously applied. These results are such that it may be affirmed that this terrible plague, from the ravages of which we have suffered

for more than two years, is, however, of all epizootics, the one of which it is most easy to become master under ordinary circumstances, and with a well-organized sanitary staff. This is because, being a stranger to our country, it is not susceptible of taking root there. Arising entirely from contagion, it is only by that means upheld; and when its cause is suppressed, it is absolutely certain that it will itself disappear, as is witnessed by all ages and in all places. But if this is so, how is it that we ourselves have so much difficulty in getting rid of it; and that even now, after the lapse of nearly two years since its first appearance, it still rages in certain localities in some of our departments? In the first place, the plague made its appearance in consequence of a combination of disastrous circumstances; and having been imported by means of the commissariat of a foreign army, it was able to extend itself without check over a large extent of country, and was even assisted in its march and extension, by the going and coming of the troops. This result was still further increased by those who made use of the cattle-plague as a source of profit, and who, for that purpose, engaged in a speculative traffic, which consisted in purchasing in the infected districts, at a low price, beasts already contaminated, for the purpose of selling them at a higher price in districts where the plague was not then known.

The mischief had already acquired enormous proportions, when the central administration of agriculture, having once more become master of its actions, undertook to contend against it. But we do not possess in France a sanitary service organized as it should be, so that all sanitary requirements could be executed as they were deemed necessary, and so that every resistance could be immediately surmounted. In France, the difficult task of executing these requirements belongs to the municipal authorities; in Germany, this mission is confided to a councillor, who is delegated by the administration, and is assisted by a Veterinary Council. This councillor is invested with powers which give him the right to command the local authorities, and even the military, to assist him in carrying out, to the extent that is necessary, such regulations as circumstances require to be immediately applied and rigorously maintained. With a sanitary service as well organized, the struggle against the epizootic would be easy, and success would be certain. From time to time, in fact, it has made incursions into the Prussian provinces adjacent to the Russian empire, but the ignited foci have been extinguished as soon as they have been kindled, and an impassable barrier has immediately been opposed to the progress of the contagion.

In France, to obtain the same results as in Germany, it would

be necessary to have a sanitary service organized in the same manner, because we ask the municipal authorities to do more than is possible for them in the midst of their place of habitation, with the conditions of their origin, and with the prejudices of their constituency. We must, in fact, avow that we do not always know how to bend to the law, and to accommodate ourselves to its yoke. We have also a much greater tendency to avoid them, when those who are charged to impose them live with us on those intimate terms which weaken authority. Under such conditions, the powers of a sanitary police, which are given to the Maires by the French law are, it should be remembered, too frequently at least, not placed in hands sufficiently energetic. Here is, therefore, one of the principal causes of the difficulty of application of sanitary measures, as they cannot produce their proper effect, except when they are everywhere carried out in their entirety. One single omission for a single moment, and contagion will find a road open before it; thus it is spread, and thus is lost all the advantage which has been obtained by the efforts to restrain and extinguish it. For instance, when it is forgotten to disinfect a railway-waggon which has conveyed diseased animals, this waggon—a receptacle for the germs of contagion—transmits them to all the ruminants with which it is loaded the next time; and by their intermediary it will disseminate them in passage, even to a long distance. Numerous reports, transmitted to the central administration, carry evidence that, in too many cases, railway waggons which have not been disinfected have served as vehicles for the cattle-plague, and have been the most active instruments of its dissemination.

In Germany all is quite different. The trucks which have been used for the carriage of beasts are submitted to a disinfection before being employed again for the same purpose. Water falls from a raised reservoir, and by its downfall and the force of its flow, it detaches and carries away the organic materials adhering to the sides. Besides this it annuls, by the elevation of its temperature, all the virulent activity in these materials.

I have believed it necessary to enter into these details because the practice of compulsory slaughter, which forms the basis of all the measures which the Conference of Vienna has recommended, is too often regarded as a rude barbarous practice, and, according to some physicians, as the negation of science and art. Also, too large a number of agriculturists, inspired by false ideas, repudiate it in the name of their interests, which they thereby injure, and frequently in the name of their sentiments, with which they thereby clash. Instead of conforming to it as the law requires, they too often have recourse to clandestine

modes of treatment, and, when success appears to crown their efforts, they argue from it, by every mode of publicity, to protest against the excess of official measures, and to demand their reform. This is a view which is altogether dangerous. The question is not to ascertain whether the cattle-plague can be cured to a certain extent; it is not even disputed that, even in Europe, a minority of the affected animals, very small compared with the remainder, may escape death. But it is necessary to ask whether the animal that is allowed to live does not itself constitute a public danger, and whether, consequently, the public interest does not exact its destruction in the shortest possible space of time. The answer to this question cannot be doubtful. Incontestably, it is dangerous to allow an animal to live if it is affected with the plague; because each one of the particles of its mass is large enough, if one may use the expression, to infect the whole of a herd, or the whole of a commune, a district, a province, or even an entire continent. Most of the epizootics of plague which have, from time to time, burst forth from the Eastern Steppes upon Europe or Africa have commenced with the infinitely little, and have ended in the infinitely great. The epizootic which entailed the loss of a million head of cattle in Egypt, twenty-five years ago, was imported through the medium of a few beasts belonging to the Roumanian principalities. It was a very small herd, purchased in Esthonia, which infected England in 1866, and inflicted upon that country the enormous damage which it sustained. It was by a dozen oxen, exported from London to Rotterdam, that Holland, infected in its turn at the same period, saw the plague acquire such proportions that it became for that country, the bovine population of which is so condensed, a veritable public calamity. This infinitesimal minority of a dozen oxen entailed the loss of no less than a hundred and fifty thousand head of cattle.

We thus see what history teaches us. It is because all this is known; because we now possess a certain knowledge of the foreign nature of the cattle-plague; of its contagious properties, as the exclusive condition of its manifestation beyond its native country; of the activity of its contagion; of the diverse and multiple modes of its propagation and of its expansion; it is because, in fact, we know all the disasters that it inevitably entails when we allow its fire to kindle and increase, that the sacrifice of the smaller number ought to be required to protect and save the greater.

The practice of compulsory slaughter is then essentially rational and scientific, because it has for its foundation the most exact knowledge, acquired by means of history, observation, and experiment.

I venture to hope that the Academy will consider me justified, in consequence of the gravity of existing circumstances, in having arrested for some time its attention on this terrible murrain, which has been, and which still is, a cause of the greatest losses to our agriculture, and which inflicts such grave injuries on the public wealth.

---

XVII.—*Report of the Governors of the Royal Veterinary College to the Council of the Royal Agricultural Society for the year 1871.*

THE Governors of the Royal Veterinary College have the pleasure of submitting to the Council of the Royal Agricultural Society their Report, for 1871, on the exertions which have been made by the College, during the year, to sustain and extend the improvements already effected in the application of veterinary science to diseases of the animals of the farm.

Before entering upon any details of this subject, the Governors feel that it is due to the memory of their late Principal—Professor Spooner—to record their sense of the loss which veterinary science, as a whole, has sustained by his death. Professor Spooner, as the Council is aware, was not especially engaged in the direct education of the pupils of the College in the principles of pathology as applied to cattle, sheep, and swine; yet he rendered valuable assistance in this important department by supervision and other means. The death of the late Principal necessarily led to changes in the staff of the College, and to a re-adjustment of the several departments of instruction.

Professor Simonds has been appointed Principal of the College. His supervision will embrace education in the pathology of the horse; but without lessening the amount of instruction on the nature and treatment of the diseases of other animals. In order to secure due attention to the instruction given in the treatment of animals other than the horse, the Governors have appointed Professor Brown, of whose capability in this branch of veterinary medicine no doubt can reasonably be entertained.

The Governors have also made material additions to the curriculum of the College, and have established a summer session, in addition to that hitherto held during the winter. To meet the requirements of this change, additional instructors have been engaged, and the Governors trust that the College has now one of the most complete and efficient staff of teachers to be found either in this country or abroad. These alterations and improvements are fully in accordance with the understanding arrived at between the two institutions, and the Governors are

confident that they will tend to the advancement of veterinary science, and to an increase of its value by the public.

During the past year seventy-five candidates, having passed the matriculation examination conducted by the College of Preceptors, have entered upon their studies; and during the same space of time forty-seven students, who had completed their term of study, have been admitted members of the Royal College of Veterinary Surgeons. The Court of Examiners of this body is so constituted that every student has to undergo as searching an examination on cattle pathology as on any other division of his collegiate instruction. It will thus be seen that no veterinary surgeon of the present day can commence practice with a knowledge of the diseases of one animal only, a circumstance of no small importance to the agricultural community.

The lectures on cattle pathology have been regularly delivered four times a week; besides which advantage has been taken of the receipt of numerous specimens of organic disease from veterinary surgeons and also from members of the Royal Agricultural Society, to explain to the students the nature of the changes which had taken place, their several causes, and also the principles of prevention, mitigation, or cure, which should obtain in each particular case.

A few years since, the Governors had occasion to express their regret that the efforts of the College to procure specimens of cattle diseases from the country received but little support; they have therefore the greater pleasure in reporting to the Council that there is no lack of interest in this respect now manifested on the part of members of the Society.

Experience has proved that the difficulties in the way of sending living animals, when suffering from disease, from the farm to the infirmary, are to a great extent insurmountable. The value therefore of each morbid specimen, especially when accompanied with a history of the case, is greatly enhanced. It is to be hoped, therefore, that a determination to send such specimens will be still adhered to, and the Governors venture to express their conviction that the advantages of the practice only require to be more widely known in order for it to be more largely adopted.

It should likewise be borne in mind that investigations of the kind alluded to have often a value far beyond that of the mere treatment of the disease, as they frequently point to the means which should be adopted for its prevention.

Apart from diseases of a special infectious or contagious nature, which are only to be kept in check by a thorough and complete investigation of the laws which govern their spread, the maladies of herbivorous animals, and especially those which come

under the ordinary designation of farm-stock, have for the most part either a climatic or dietetic origin. Morbid anatomy often explains the cause as well as the nature of disease; and be this common or specific, it directs the investigation into the right channel for lessening or removing the immediate cause of the mischief.

It may also be affirmed that it is the especial province of veterinary science to be prophylactic, and that in proportion to the application of preventive medicine so will be the value of the science to the community.

The experience of the past year has shown, that diseases of an ordinary or common type have not been very rife, while, on the contrary, some of those which depend on special causes, have been more than usually prevalent.

In the early spring months, splenic apoplexy broke out on several farms in the Midland Counties, on which the same disease had appeared the previous year. In each instance, nearly every animal died after a few hours' illness. Some of the attacks afflicted cattle at grass, and others those which were being stall-fed; and neither age, breed, nor system of feeding, appeared to influence the attack or the fatality attending it.

With regard to measures preventive of this disease, it may be remarked that these ought to be energetically persevered in, as well as had recourse to on the first appearance of the malady. The free use of antiseptic agents, especially the sulphite of soda, conjoined with chloric and sulphuric ether, and the thorough cleansing of the yards, even to carting away the manure, and subsequently disinfecting them with carbolic acid, are the prophylactics which offer the best chance of success.

Another disease, allied in its pathology to splenic apoplexy, viz. "black-leg" (*Hæmato-sepsis*) was unusually rife in some districts, especially in those where high-bred animals are kept, and where various means are employed to bring them quickly forward in condition.

The fatality of "black-leg" is always great, the disease being one of those in which the blood quickly undergoes changes, which render it incapable of supporting life.

It is scarcely necessary to remark that blood-diseases are among the most fatal of all maladies, and that they rarely admit of cure. Preventives must therefore be looked to, and essentially those, which have been previously alluded to, ought to be adopted in sudden outbreaks of black-leg. A periodic exhibition of saline aperients, the use of setons, an occasional blood-letting, care in selecting the best kind of food, and due discretion in its use, so as to avoid bringing the animals too quickly into a state of plethora, are also effective means of preventing the malady.



Passing from enzootic to epizootic affections, and notably to the one designated Cattle-Plague, it is a source of much satisfaction that this disease—the most infectious and fatal of all known maladies affecting animals—has not again been imported from the Continent.

No better proof can be given of the value of existing legislative measures in limiting or controlling the spread of infection. Twice during the year the Lords of the Council found it imperative to issue Orders preventing the importation of cattle from Belgium, and also fresh meat, fresh hides, unmelted fat, hoofs, horns, manure, hay, &c., while the continued existence of cattle-plague in France required the rigid enforcement of the Order against importation of bovine animals from that country. The loss which France has sustained during the year from cattle-plague must have been enormous. The state of the country seems to have paralysed the efforts of the authorities to rid France of the disease, and even to have given encouragement to attempts at its cure, than which no surer means of spreading the area of the infection could be devised. France will doubtless have to reckon her losses by hundreds of thousands, while, in 1865, she freed herself of the cattle-plague, by the prompt adoption of the stamping-out system with a loss of only forty-three animals.

Next in importance, as a fatal cattle disease, stands pleuro-pneumonia. Throughout the year this malady has undergone very little variation, and although existing in upwards of forty counties in Great Britain, the actual centres of disease have not averaged more than seven or eight in each county. Among the remedies which have been brought prominently before the public as curative, as well as preventive, of pleuro-pneumonia is carbolic acid. This remedy, some years since, was tried by the professors of the College, but without their being able to satisfy themselves that it possessed any really curative power, or even preventive, excepting as a disinfecting agent. The pathology of pleuro-pneumonia shows that it must ever be ranked among incurable diseases. It is true that many animals recover from the immediate consequences of the attack; but, perhaps, never without some portion of the lungs being left more or less in a disorganized condition. The so-called recovered cases of pleuro-pneumonia are often the *foci* of infection; the true policy therefore of the farmer is to get quit of such animals as quickly as possible.

Another of this class of diseases is the one commonly known as the "foot-and-mouth disease," an affection which very often causes serious losses to the stock owner, although it rarely produces death, except in young animals. The chief facts relating to the spread of this malady have often been brought

before the Council in the Annual Reports of the Governors, and, but for the circumstance that the disease has been more than usually severe, and far wider spread, all mention of it might have been omitted from this Report. Early in 1871 the malady began to seriously increase, and since then it has prevailed with more or less virulence in every part of Great Britain and Ireland.

The importation and free movement of Irish store cattle throughout the country have greatly contributed to the malignancy as well as to the spread of foot-and-mouth disease.

Cattle fairs and markets are the great centres of infection, especially those for the sale of store stock, and these, as is well known, are largely supplied from Ireland. The foot-and-mouth disease may, unfortunately, be considered as naturalized, for since its first appearance, in 1839, it has never been completely absent from the country. Like other epizootic affections, it assumes a more serious form in some years than in others, and many of these periodic outbreaks have occurred comparatively recently both here and on the Continent.

Doubtless, during the past year, animals have been imported from many parts of Europe, which, on arrival, were found to be suffering from the disease. These, however, have been dealt with at the several ports in a manner to prevent much, if any, mischief directly resulting from their importation. It should ever be borne in mind, in estimating the amount of injury likely to arise from such an event, that there exists, independently of it, all the conditions within this country necessary for the periodical increase of foot-and-mouth disease.

The Governors abstain from adding to the length of this Report by alluding to other diseases of cattle, or by making mention of special investigations which have been conducted at the College by their present Principal at the instance of the Society. Some of these have been already reported, and also published in the Society's Journal; others are being carried out, and will, when completed, be also reported to the Council. The more recent arrangements which have been made between the two Institutions have among other things resulted in the substitution of quarterly reports, for those which had hitherto been annual.

This greater frequency of intercommunication, the Governors are encouraged to hope, may cement more closely the science and practice of Veterinary Medicine with the science and practice of Agriculture.

C. N. NEWDEGATE, Chairman.

---

---

XVIII.—*Report on the Importation of Animals affected with Cattle-Plague during the month of July, 1872.* By Professor J. B. SIMONDS, Principal of the Royal Veterinary College, and Consulting Veterinary Surgeon to the Society.

To H. M. JENKINS, Esq., *Secretary, Royal Agricultural Society.*

SIR,—I have the honour to report, for the information of the Veterinary Committee, that, during the last fortnight of July, several importations of cattle suffering from cattle-plague have taken place into this country; and, although it is not at present known that the disease has gained a footing here, still the most serious apprehensions are entertained lest it may have done so.

Before giving the particulars of the several importations, it is necessary to state that, for many past weeks, it has been known that the cattle-plague was prevalent in some of the Baltic provinces of Russia, and in contiguous districts. This was especially the case with regard to the provinces of Petersburg and Novgorod, from the former of which large exportations of cattle have taken place to Cronstadt, from which place we have received the disease.

The first ascertained instance of the importation of the malady took place on July 17th. The animals were shipped at Cronstadt in the 'Leda,' and were landed at Deptford Foreign Cattle Market. They were a small lot of 25, and, at the time of landing, no special indications of cattle-plague were detected; but it was noticed that some of the animals seemed to have suffered more than ordinary fatigue from the voyage. On the morning of the following day the Inspector, on making a second visit, found that one of the animals had died in the interval. This circumstance at once raised a suspicion of the existence of cattle-plague in the herd, and a post-mortem examination was forthwith made, when all the characteristic lesions of the disease were detected. A close examination of the other animals, and the application of the thermometer test, showed the existence of premonitory symptoms of the disease in three more of them at least. The whole were, therefore, slaughtered as quickly as possible, and the diseased animal destroyed by placing the carcass in a steam apparatus which had been specially erected for purposes of this kind. The skins of all were disinfected, and also the slaughter-house and other places which the animals had occupied, besides which that part of the market was closed against any other importations.

In consequence of this introduction of the disease the importation of cattle from Russia was prohibited by Order of Council, and directions were also given by the same Order for the slaughter, within the defined parts of ports, of all sheep and goats coming from Russia.

Case 2. This case has been thought to be one rather of suspicion than otherwise; nevertheless the whole history of the recent introduction of cattle-plague points to it as being a positive instance of the importation of the disease. A vessel, the 'British Queen,' came into Hartlepool on July 21st, having on board 63 cattle and 25 sheep. Although shipped at Hamburg, the cattle were not all of German origin, 15 being of Russian breed. They were slaughtered within the defined part of the port, but before the slaughtering was completed one of the Russian animals was noticed to be ill. This fact coming to the knowledge of the Inspector, he followed the carcass to the public slaughter-house, whither it had been taken to be dressed, and found the viscera to exhibit such peculiar lesions as to warrant his conclusion of the illness having been due to cattle-plague. In consequence of this, the carcass was destroyed, and the skins of all the others disinfected. The sheep, also, were slaughtered within the defined part of the port; a measure rendered necessary because the German cattle, with which they came, were found to be suffering from the foot-and-mouth disease. If the Russian ox was really the subject of the plague it must be regarded as a most fortunate coincidence that the German cattle were suffering from foot-and-mouth disease, otherwise it is possible that the plague might have been carried from the port into the country by the sheep. As the case stands, it cannot be regarded as one from which danger is likely to arise; nevertheless, under existing circumstances, it is of sufficient importance to be noticed in a report of this kind.

Case 3. The importation in this instance was into the port of Leith. The steamship 'Benachie' arrived outside the docks during the night of July 22nd, having on board 50 cattle, and a general cargo of hemp, from Cronstadt. The Inspector went on board about 5 o'clock on the following morning, when he found that several of the animals exhibited symptoms of ill health, and that three in particular showed indications of the existence of the cattle-plague. The local authority was forthwith communicated with, and instructions given to prevent the landing of the beasts.

During the day, at the solicitation of the Inspector, Professor Williams of the Edinburgh Veterinary College, Mr. Walley, also an officer of the College, and Mr. Baird, Veterinary Surgeon, examined the animals and confirmed the opinion of the Inspector. Telegraphic communications were sent to the Veterinary Department of the Privy Council, and directions received for the slaughter of the beasts. The Inspector went on board accompanied with proper slaughtermen, and, in order to facilitate the disposal of the carcasses, the vessel steamed out to sea, and

when many miles from the shore they were thrown overboard. So rapid was the progress of the plague, that by this time thirteen of the animals were evidently affected. All the animals were disembowelled, but not skinned. Besides the carcasses of the diseased, the viscera and the skins of the others were also thrown overboard, and the healthy cattle, as "sides of beef," brought back to Leith. By the time the vessel was again in dock it was found that the "sides of beef" were not in a condition to be used for food, or safely landed, and, consequently, they were put on board a lighter, taken into the Firth and thrown overboard. The vessel was subsequently cleansed and disinfected.

In this case it is to be regretted that some of the viscera, and it is also said some of the carcasses, have been washed ashore. With regard to the latter statement, it may be remarked that it does not appear that the carcasses of cattle which have reached the shore in the neighbourhood of Berwick are really those which were thrown overboard from the 'Benachie,' but rather of Danish cattle lost at sea. It should be further stated that one of the three cattle-plague animals died, so that the case stands thus: Cargo, 50; died, 1; killed, diseased, 12; slaughtered, healthy, 37; all disposed of by being thrown overboard.

Case 4. The animals in this instance came from Hamburg into the port of Newcastle. They were brought in the 'Brigadier,' and arrived at about 3 A.M., July 22nd. They numbered seventy-eight, 70 being German and 8 Russian cattle.

On being landed, and placed in the lair in the defined part of the port, they were seen by the Inspector, who at once recognized the existence of cattle-plague in two of the Russian beasts. The disease was so far advanced in one animal that it died shortly after being landed. On inquiry, it was also ascertained that another Russian bullock had died about six hours after being taken on board at Hamburg and been thrown into the sea. The German cattle were free from cattle-plague; but some of them were suffering from a slight attack of "foot-and-mouth disease." The whole were slaughtered as quickly as possible, and their skins disinfected. The bodies of the diseased, being first disinfected, were removed to a manure manufactory close at hand, and at once destroyed by chemical agents. The carcasses of the German cattle were carefully inspected before being delivered to their owners. Everything else, including "butcher's offal," was either disinfected or destroyed. The ship was also well cleansed and disinfected, and the landing-place and lair declared an "*infected place*" by the local authority.

In this instance there appears to be little or no doubt that the Russian cattle were in a positively diseased condition when taken on board; but as the German cattle, although brought

with them, had not been exposed sufficiently long for the period of the incubation of the infecting material to have passed, practically the animals were to be regarded as healthy, and, therefore, the delivery of their carcasses to the butchers was not likely to be attended with any risk or danger.

Case 5. In this case the diseased animals were brought into Hull by the ship 'Joseph Soames' from Cronstadt. They arrived off the port so as to allow the ship to come into dock about 9.30 on the morning of the 25th July, having left Cronstadt on the 16th. The Inspector went on board the vessel while she was lying in the Humber, and found 56 Russian bullocks on board, two of which excited his suspicion of their being affected with cattle-plague. When in dock the vessel remained in charge of the Customs, and none of the animals were allowed to be landed. It was ascertained that two bullocks had died at sea and been thrown overboard—one on the 20th and another on the 22nd.

An opportunity was afforded me of enquiring into the facts of this case, and on inspecting the animals on the morning of the 26th, I found the disease to be making such rapid progress, that from eighteen to twenty of them were now affected. Prompt action was taken; the whole were slaughtered on board under the supervision of the Inspector of the local authority. None were allowed to be opened, but all were placed in two lighters and towed by a steam-tug out to sea for the purpose of being sunk, in accordance with the arrangements which had been made.

In this instance, as there was a considerable quantity of material on board likely to convey infection, the cargo being a mixed one, arrangements were made by which the Local authority was to see that disinfection of the holds of the vessel was properly carried out before their contents were allowed to be landed; and after the slaughter and removal of the cattle, that the decks of the vessel were well cleansed and disinfected, as well as the men employed in slaughtering the animals. From what has since transpired, it would appear that the lighters were not sunk as had been provided for; but were left afloat with the carcasses on board. This is much to be regretted; but with whom the error rests, I have not at present been able to learn.

Case 6. This was a second importation into Hartlepool, and, as in the former instance, the animals came from Hamburg. They were, however, all German cattle—a fact of great importance in itself, but of still greater when taken in connection with an importation of German cattle into Newcastle, the subjects of cattle-plague.

The animals, 26 in number, were brought in the 'Gipsy Queen,' and entered the docks about 10 P.M., July 28th (Sunday). The Inspector went on board before the ship was brought into

dock, but did not detect any symptoms of disease in any of the cattle. They remained on board until about about 5 A.M. (Monday), when they were landed and carefully examined, again without disease being detected. They were seen again at noon on Monday, and then also they gave no indications of ill-health. At 6 P.M. they were finally examined by the Inspector and passed; but, coming from a scheduled country, they were prevented leaving the defined part of the port alive. On Tuesday morning two or three of the animals were noticed to be unwell, and one in particular to present symptoms of cattle-plague. Under these circumstances their owners commenced the slaughter at once, and the Inspector telegraphed to Newcastle for the Inspector at that port to come to Hartlepool. At the time of the arrival of the telegram I was engaged at Newcastle with the Inspector in examining German cattle from Hamburg, among which one decided case of plague existed. After making arrangements at Newcastle to prevent a spread of the disease from that centre, we left for Hartlepool, and arrived so as to examine the animals about 5 P.M. The disease was found to be making fearful and rapid progress, there being no less than seven or eight then affected with cattle-plague. Measures were promptly taken to prevent any of the slaughtered animals, skins, offal, or other material, leaving the place, and the local authority was communicated with. The slaughtering was at once stopped, and the men and their clothes dealt with in a way to prevent, if possible, any mischief resulting. The place was also put in charge of the police, until a meeting of magistrates could be held in the morning. At this meeting it was determined to bury the whole lot—an examination of the viscera of some of those slaughtered giving indications of the existence of disease. One of the cattle-plague animals died in the night, 10 were killed diseased, and 15 slaughtered as healthy—26. All were removed by water to the burial-place—an isolated spot contiguous to some new docks which are being constructed—and there properly disposed of. This, as well as the landing-place and that part of the dock from which they were taken, were cleansed and disinfected, and declared an "infected place," in accordance with the provisions of the Contagious Diseases (Animals) Act.

Case 7. This also was a second importation of the disease, and has already been alluded to as occurring at Newcastle. The animals, which numbered 103, were all German cattle, brought from Hamburg. They were landed at about 7 A.M., July 29th (Monday), at which time they all appeared to be in a healthy state, as was the case, with one exception—a heifer—that appeared more than usually dull and dispirited, when seen by the Inspector after the twelve hours' detention. Under these circumstances the

Inspector determined to isolate this animal, and to detain all the others until the following morning before making his next examination. Late on the same evening I arrived at Newcastle from Leith, and in the morning accompanied the Inspector to the lair and examined the animals. The heifer was found to be the subject of cattle-plague; the disease being not only fully established, but making rapid progress towards a fatal termination. We at once determined on killing her, disinfecting the body and sending it to the adjacent manure manufactory for immediate destruction. This being done, the slaughtering of the others was commenced under supervision and such regulations as would give fair security against harm arising, even if some of the animals should show indications of disease before the whole were slaughtered. The final result I have not yet been able to ascertain, but I have no doubt that everything was done to guard against a spread of the infection that possibly could be.

The occurrence of these cases of cattle-plague among German cattle are sufficient proofs that the malady has gained a footing in the neighbourhood of Hamburg, from the importation of diseased Russian cattle from Cronstadt into that port.

Under these circumstances the Lords of the Council saw fit to issue an Order bearing date July 31st, revoking the Order which allowed Schleswig-Holstein cattle to pass inland after twelve hours' detention at the place of landing, if healthy; and also by another Order, of equal date, to determine that all sheep and goats brought from any place in the Empire of Germany should be killed at the port of entry.

One other case of importation of cattle-plague still remains to be named. The animals, 35 in number, destined for London, were shipped at Cronstadt on July 20th, but were not landed until July 28th. They came to the Foreign Cattle Market at Deptford, and were brought in the steam-ship 'Viatka.' Five died on the passage—the cause assigned being simple exhaustion from the length of the voyage. Three of the five died on July 26th, and two on the 28th, when the ship was off the Essex coast. They were all thrown overboard—the two last-named near to the "Sunk Light," off Harwich. On being debarked three were found to be in an unhealthy condition, and one of these to present symptoms of cattle-plague. Immediate slaughter of the whole lot was ordered by the Lords of the Council, and such a disposal of the carcasses as would afford security against the spread of the disease. The *post-mortem* examination of the animals alluded to fully established the opinion which was given during life, namely, that the symptoms which existed were due to cattle-plague, and to no other disease.

In concluding this Report, I may add that advantage has been



taken of the reintroduction of cattle-plague to test the disputed conveyance of the disease to animals by their partaking of water containing the *materies morbi* of the malady. Some exudation matter and viscid mucus were removed from the fauces of a diseased German cow and mixed with a pail of water, which was then given to a yearling heifer to drink. She refused to swallow more than a draught or two; but being kept from water for two succeeding nights and the intervening day, she freely partook of the remainder. On the *third day* following the last drinking of the water she presented appearances which to the practised eye indicated that mischief was beginning, and the thermometer test being had recourse to, the temperature was found to have already risen to  $105\frac{2}{10}$ . On the following day the symptoms of cattle-plague were well marked, and from that time the disease progressed so rapidly that death followed on the *fourth day of illness*, and *ninth* from the time the infected water was first partaken of.

It may be right to add that the experiment was carried out under circumstances which rendered it impossible that the animal could in any other way, save by drinking the water, have been exposed to the infecting material of cattle-plague. Its result fully confirms the opinion arrived at during the prevalence of the disease in 1866, and establishes the views held by the best of the Continental observers.

---

#### ADDENDUM.

[Since sending the preceding Report the cattle-plague has broken out in the East Riding of Yorkshire; but, at the time of my adding this note, the disease is almost entirely exterminated. The necessity of a speedy publication of this number of the Journal prevents my now giving the particulars of the cause of this outbreak of the malady. So far, however, as an investigation has gone, I may state that it in no way depended on the washing ashore of the carcasses of the animals which ought to have been sunk off the mouth of the Humber.—J. B. S.]

---

#### XIX.—*Report on the Exhibition of Live Stock at Cardiff.* By HENRY CORBET.

A LOOK at the map or a glance through the records of the Society will tell how it is just twenty Shows since the annual exhibition approached on the confines of South Wales. And then, so far as drawing forth the resources or illustrating the strength of the country could be concerned, the result in 1853 was very similar to that in 1872. At Gloucester the Society had certainly not penetrated so far as when it travelled on to Cardiff; but a quarter of a century or so back, the Welsh farmers

might have been assumed to depend mainly on their own breeds of stock, and so to have given an occasional idiosyncrasy to the scene. At Cardiff, so general has been the advance of improvement, the home-breeders made more mark with their Herefords, Shorthorns, and Cotswolds than anything else; and at Gloucester they made no mark whatever. Mr. Richard Milward, the senior steward of that meeting, says in his Report, "the Welsh breed was a complete failure: 70*l.* was offered by the Society, for which only five animals were shown, and these were not worth the amount of the prizes." Of these five, three were brown and white, and two black animals. The brown and white were of course the old Glamorgans, of which I could gather little more at Cardiff than that they had fairly died out. Although good beef, they ripened slowly, and, after vain attempts at crossing, have been out-paced by more modern breeds on their way to market. The black Castle-Martins hold their ground more firmly, but I remember a better show of the sort a few years back at Carmarthen, as there no doubt will be again in September, when some champion prizes will be offered. In fact, the breed was done scant justice to here by the exhibitors; and when, during last autumn, Sir Watkin Wynn recommended his friends in Cheshire "to go to Cardiff next summer and see for themselves whether the black cattle of South Wales were equal to the black cattle of North Wales," the President, no doubt, expected there would be a far stronger display of native produce. It is noticeable, however, that, much as they may be coveted by the grazier or sought by the butcher, neither the North nor South Wales cattle ever offer much front as show stock. There may be a runt or two entered at Bingley Hall or at Islington, but the competition rarely extends beyond the number of premiums.

The main features, then, of our great national expositions in this way are becoming more and more alike. There will be Shorthorns shown this autumn at Hereford fair; and at Exeter last spring, on the opening day of a new Devonshire Society, the Shorthorns beat the Devons for the champion prizes. When another great meeting is called for the Midlands, there will probably be as many Longhorns sent from Leicestershire and Warwickshire as were sent to Cardiff—some three or four in all. Reporting on Gloucester in 1853, Mr. Milward said, "We may now hope that after repeated trials with the best intentions to draw out the cattle peculiar to a district, the Society will cease to offer prizes for any but the three recognized breeds of cattle." And certainly at Cardiff "the cattle peculiar to the district" would by the event appear to be cattle whose peculiarity is that they are known all over the world—such as Shorthorns and Herefords: whereas the Castle-Martins, the Angleseys, the Montgomeryshires, the Red Polls, and the Ayrshires, were,

as tested by their numerical force, little more than curiosities. At Gloucester, however, a vain attempt was made to check the over-feeding of show stock, and since then some more direct encouragement has been offered for another description of animal product. The Society now goes, not merely for beef, but for milk, and to Mr. Milward's three recognized breeds of 1853 we must now add and maintain a fourth. There was not, perhaps, a great show of these animals at Cardiff, but there is none more interesting or useful in its degree than that of Channel Island cattle, and, like the horse show, this section has now, too, been properly cultivated and become an established success.

And of the Royal Society's horse show of twenty years since, let so good an authority on the subject as Mr. Milward speak to its merits:—"Although many were exhibited, it cannot be stated that the show was a good one. There were, it is true, several fine specimens of the Suffolk breed, but the judges expressed great dissatisfaction at the ordinary show of roadster stallions; and the exhibition of Welsh ponies will not, it is thought, induce the Society to offer similar prizes in future." In fact, at that period, and for some years subsequently, a horse show under the countenance of the Royal Agricultural Society was despaired of; and at Gloucester there were no classes beyond those just mentioned—for cart-horses, one premium for a trotter, and a few special offers for ponies that a "horse" man like Mr. Milward would seem to imply should never be repeated. But at Cardiff, Mr. Milward was himself an exhibitor of ponies, as there were classes for thorough-bred horses, hunters of all ages, cobs, galloways, and brood mares; so greatly has this part of the proceedings developed since the first Royal 100*l.* was offered at Leeds in 1861. Nothing, however, could have been more legitimate than this very gratifying success; but the lofty jumping and tumbling is not countenanced, nor is the tedious business of judges riding the horses encouraged by the stewards. A horse-show of any kind will always be an attraction to an Englishman without bushed hurdles and brimming dykes. What with separate classes for Shires, Clydesdales and Suffolks, the agricultural horses have progressed as favourably, with the exception, at least at Cardiff, of the Eastern Counties chestnuts. At Gloucester "there were several fine specimens of the Suffolk breed;" at Cardiff there were very few specimens of the Suffolk breed, good or bad, and not half-a-dozen in all.

In the twenty years there has been no greater enterprise evinced, that is to say, as demonstrated by the prize-list of the Society, than in the breeding of sheep. At Gloucester the several distinctions were thus drawn—Leicesters; Southdowns or other Short-wools; Long-wools, not Leicesters; with special prizes for Shropshires or other grey and black-faced Short-wools. Thus, there

were in all four varieties of sheep recognized which have now expanded into Leicesters, Cotswolds, and other Long-wools; Oxfordshire Downs, Southdowns, Shropshires, Hampshires, and other Short-wools; Dorset, and Mountain sheep. What a story this comparison tells of itself! and one as interesting as it should be useful. Mr. Milward said in those times "the new class of Shropshire Downs was very successful," and "it is to be hoped that the Society will recognize them as a distinct breed;" but how many more distinct breeds have we set up since Gloucester? Even the Cotswolds at that time held no rank of their own on the prize list. And, then, the pigs, merely separated as large from small, with no Berkshire class even on the confines of their county, but with "a dark and white Berkshire" sow winning a prize, though this would be regarded as rather a curious description of a Berkshire by the connoisseurs of a later era. Still the Rev. T. C. James, more recently than Gloucester, would bring out his "improved" Berkshires, very gaily marked with great patches of white on their sides, backs, and even heads. It must be understood that I do not write here altogether from hearsay or by book, as I was at the Gloucester Meeting, and have still a keen recollection of that miserably wet week and swampy show-ground, serving as they may to further point the comparison in favour of Cardiff, with its sunny skies and pleasant rambles from one ring to another.

#### HORSES.

Only within a few days from the time I write, I saw what, with the pardonable license of "the hammer," was called "the best horse in the world," knocked down for the unprecedented price of 12,500 guineas, the purchase being made for a new Stud Company. Considering that we have Parmesan, the sire of the last two winners of the Derby, and King Tom, still, as it would seem, in their prime, as well as so rising a sire as Lord Clifden, already credited with two St. Leger winners, it is not quite so clear that Blair Athol is the best horse, or, at any rate, the best stallion in the world, or even in the country. I should look, myself, with far more confidence to another Stud Company for the best horse, that is, of his breed and for his purpose. I, of course, refer here to the Shire cart stallion Honest Tom, who has won at every meeting of the Society from his youth upwards, and at this show as the property of the Fylde Cart-Horse Breeding Improvement Company. I remember some years since, when acting as a Judge of horses for a local society, telling them at the dinner that it was their imperative duty to see that the district was provided with one or two really good "warrantable" stallions for the

use of farmers; and I think I went on to suggest that the Hunt Committee might make it part of its business to see that such a want was supplied. At the moment it did not occur to me to ask the aid of that good fairy who in these times is ready to undertake almost anything we choose to name, from compounding a cattle-food to draining a bog; but certainly never did the agency of a Company promise better, as a means for the public good, than that recently established in Lancashire. There is so much example in that which has already been accomplished, the project so far has been so legitimate a success, that I am induced to give here a glance at its origin and object. From the official note-book of the Company, as kindly placed at my disposal, it appears that the efforts of the Royal North Lancashire Agricultural Society, and the Lytham and Kirkham Agricultural Society, to induce good thorough-bred horses to come into the district of the Fylde by offering a premium of 50*l.*, not having produced a satisfactory result, it was thought expedient by those who felt an interest in the subject, to ask the landowners and other gentlemen in the neighbourhood, to combine in raising a sum of not less than 500*l.*, in shares of 25*l.* each, for the purchase of a really good thorough-bred sire. The Rev. L. C. Wood accordingly brought the subject before the notice of the principal landowners, and the following gentlemen at once consented to aid the proposed scheme by taking shares, viz.:—Lord Derby, 4 shares; Colonel Clifton, 4; Mr. J. H. Miller, 4; Mr. T. Townley Parker, 1; Mr. C. Addison Birley, 1; Mr. Leyland Birley, 1; Captain Jameson, 1; Mr. T. Langton Birley, 1; Hon. D. B. Ogilvy, 1.

This was termed the Fylde Horse Breeding Company, and in due course, as will be seen from the following further minutes, the one led on to the launch of another, distinguished as the Fylde Cart-Horse Breeding Improvement Company:—In the year 1868 a Company was formed for the purpose of improving the breed of horses in the Fylde, and with this view the thorough-bred horse Carbineer was purchased from the Earl of Zetland. After three years' experience, the promoters of that scheme have every reason to be satisfied with the result of their efforts; and they consider that the numerous premiums won at the various agricultural meetings during the last two years by the young stock got by Carbineer, bear the best testimony to the progress that is being gradually made in this class of stock throughout the district. This success leads the promoters of that scheme to think it desirable that their operations should be further extended, and that the means placed within the reach of the agriculturists of the neighbourhood for improving all classes of stock should be completed by the introduction of a first-class cart-horse. With this view it is proposed to orm

another Company, to be called 'The Fylde Cart-Horse Breeding Improvement Company,' and that it be managed upon the same principle as the former one. That the capital of the said Company shall consist of 600*l.*, to be raised in shares of 25*l.* each. The Rev. L. C. Wood having brought the subject before the various landowners, the following took shares, viz.:—Lord Derby, 4 shares; Mr. J. T. Clifton, 4; Mr. T. H. Miller, 4; Mr. W. P. Miller, 4; Lord Bective, 3; Mr. T. T. Parker, 1; Mr. T. Langton Birley, 1; Mr. C. Birley, 1; Mr. C. A. Birley, 1; Mr. A. L. Birley, 1; Mr. Hutton Birley, 1; Mr. Spencer Leese, 1.

The thorough-bred horse Carbineer was purchased of Lord Zetland for 400*l.* in 1860, the year in which he won the Society's 100*l.* at Manchester; and Honest Tom of Mr. W. Welcher for 500*l.* The selection and management of these two stallions have been entrusted to a committee, consisting of Mr. T. Townley Parker, Mr. T. Horrocks Miller, and the Rev. L. C. Wood; and the horses stand at Singleton, near Poulton-le-Fylde, in the centre of the Fylde district. Since his purchase, Carbineer's stock have been winning at many of the great shows throughout the country, and at a recent meeting in Lancashire his foals of this year beat an equal number of those by Sincerity in a match; while Honest Tom's six years' successive victories are as well backed on the prize list. So far, then, the Company's capital has been judiciously invested; and although Lord Derby and the other gentlemen who have taken shares may not have looked to much direct return therefrom, there will be a profit in many ways.

For some years past Young Lofty has also been known at the Society's Meetings, as well as about the country, as the best Clydesdale, at least on this side of the Border; and a very delightful horse he is—cheerful, active, and particularly handsome. He was put out here, however, by the Assistant Veterinary Inspector as a roarer; while it is noticeable that at Malvern last autumn, where I was one of the Judges, a question was raised by one of my fellow-Judges as to Young Lofty's soundness, and a veterinary surgeon called in. The horse, however, was passed as sound, and he took the first prize; while, it should be added, that no objection was then made as to his being a roarer. There was no such thoroughly stylish a cart-stallion at Cardiff, and the Judges with what they had before them in the class must have looked with longing eyes at the corner in which Lofty was "sent to Coventry" under the ban of a disqualification.

There was a far better show of Suffolk horses at Gloucester in 1853, when the Punches took nearly all the prizes in mixed classes against other breeds, and when Mr. Milward stated officially there were several "fine specimens of the breed." At

Cardiff, as I have said, there were hardly half-a-dozen in all exhibited; and, as the Suffolk breeders are evidently not very keen for competition when far away from home, it is a question whether these classes should not be dropped at remote sites like Cardiff and Hull, to, of course, be revived again when the Society comes close on them in 1874. There is no worse advertisement than badly-filled classes at a great national meeting; and at Cardiff two Suffolk stallions competed in the old class, only one two-year-old was entered, backed by a couple of mares. Considering how much the character of the Society's horse-show has improved, and how much it has extended, as, further, that the Suffolks had here a series of premiums to themselves, it is not so easy on the face of it to say why the Gloucester show of this breed of cart-horse was so good and that at Cardiff so bad. If the classes be continued at Hull, the Eastern Counties must make a far stronger demonstration for Yorkshire, or people will say the Suffolks are going out of fashion.

Grand as are such horses as Honest Tom and Le Bon, and weighty as is the chestnut Young Champion, it is doubtful whether they were quite in place in Glamorganshire, for the Welsh farmers can never "afford" to take to them as they do to the Herefords and Cotswolds. The light, active little horse is of far more service here; and, indeed, one of our leading implement-makers tells me there is a call for this comparatively small horse in many other parts of the country, —for something not over fifteen-two, compact, and, above all, active, who with his fellow can step away in a pair-horse plough. The abuse or excess we are growing into on the show-ground is that too many of the prize cart-horses have rather the extra weight and ponderous movements of dray-horses. Even the Suffolks are shown with more top than they can comfortably carry, but then this is called "constitution." The following is the Judges' Report on the agricultural horses; which, I should say, only reached me after I had written the opening to the section:—

In the following remarks, the Judges, as far as possible, confine themselves to opinions upon which they are unanimous; and when their comments extend to animals beyond those selected for official awards, it will mostly be found to be for the purpose of drawing attention to extraordinary merit, in cases where unsoundness or other objection has prevented a more marked appreciation being recorded in the shape of prize or commendation.

A Judge at a Royal Meeting is not supposed to need apology or justification for decisions made with the consent of his colleagues, but instances may occur in which a few words of explanation may at once afford a satisfactory solution to what, outside the ring, may appear an unsolved mystery. Of this the Judges will take advantage, where such explanation may appear necessary or advisable. Where marked inferiority is specially noticed, it is for the purpose of deterring owners from making entries for Royal prizes, upon what may be called off-chances in a thinly-filled class. Animals thus

placed before the public, lower the general standard of the exhibition, and the practice tends to mislead beginners as to what is and what is not a proper animal for a Royal Society's showyard.

The withholding a premium under any circumstances is a very extreme measure. In one case only did the Judges consider themselves justified in resorting to it; but had some of the better-filled classes been reduced to certain entries, this verdict of "insufficient merit" would not have been a solitary one.

In the directions given, the Judges of cart-horses have received no special instructions as to the nature of the report they are expected to produce. What follows is written under the assumption that every one who makes an entry in the Royal Agricultural Society's Catalogue submits his animal to the verdict of the public, both through the Judges' award and the notice of the press. To commit to paper for public record some general commendatory remarks on an individual animal, or some remote allusion to lack of merit in a certain class, without particularizing anything in it, is not a very profitable employment; it is satisfactory to neither writer nor reader. In the task we have undertaken, we do not feel bound to confine our remarks to mere generalization. Where an animal is pre-eminently meritorious, the attention of breeders should be called to the fact: when an animal of reprehensible inferiority makes an appearance in the ring, his owner is responsible for the adverse criticism which is likely to follow.

In our Report we shall first notice the agricultural stallions not qualified to compete as Clydesdales or Suffolks. Here we had no difficulty in selecting three or four very good ones, the best of these being Honest Tom, a horse known since the Bury St. Edmund's Meeting in 1867, as a prize winner on every occasion he has put in an appearance. As a 2-year-old, at Bury, he was a marked feature in the show; he was then of great promise, and has now fulfilled the most sanguine expectations of those who thought best of him. As a young one, he had a tendency to lightness in the back ribs, having a little too much height under the flanks. This has all disappeared; he is now a good-looking, well-spread, farmer's horse, of quite the heavy stamp. With immense substance, he has quality enough in his legs to suit a Suffolk breeder, and hair enough upon them to satisfy the North or Midland Counties man—two things by no means incompatible, but not often seen in the same animal. His fore-feet are not what they should be, and he begins to show the effect of his spring work and summer "showing" on slightly arched fore-legs. The most that can be said against him is, that he is rather more of the dray-horse than is desirable in an agricultural stallion; and, perhaps, at the time the Society offered distinct premiums for that kind of animal, his entry for a farm-horse premium might have been fairly objected to on that account. The second prize went to a bay horse of great length and substance, with a somewhat deficient back; otherwise a useful animal with good action—a point which, perhaps, placed him before the white-legged chestnut so good to look at all round in the box and the ring, too; but his want of liberty in the farm-horse's great pace—the walk—kept him from a higher place in the prize list. The faults most patent to the eye in this class were flat feet, small feet, side-bones, and light middles. Very few were deficient in trotting action, but the easy swing in the walk which a plough-horse should have was not so apparent. The handsome black tottering round the ring from sheer infirmity on all-fours should be remembered—not as a model, but as a caution.

Of the 2-year-olds of the same description the best was Mr. Bryan's white-maned chestnut, a very capital style of horse without much show, but no weak point. His short hind-quarters and straight hocks are unsightly, but betray no want of strength; and to those who are aiming at extra sub-



stance and good quality, we commend this colt's legs as models to perpetuate. In Mr. Summer's grey, which took second honours, there is no great promise of beauty, but like the first-prize colt, he has no weakness to tell against him. The excessive development of muscle over the hips, with the drooping rump, is a form never deficient in strength; but at the same time is an unsightly formation, usually accompanied with a depression more or less over the loins—a rule to which the grey is no exception. The third-prize colt had anything but good hind-legs, and had a certain want of strength round his flank and loins, not likely to mend with age. His place as No. 3 on the prize list, with Mr. Jones's lengthy brown behind him, was not a unanimous decision of the Judges. Among this class were to be found several colts by no means undeserving of notice. No. 13, a particularly good-looking, lengthy bay, could not escape notice; but there was that in his run out which sent him away early in the selection. Others, again, were palpably unsound, or had falsely-formed hocks, closely approaching to unsoundness. The marked instances of false form, shallow girth, long legs, and want of width, which Nos. 14, 15, 17, and 22 exhibited, quite spoiled the look of what would otherwise have been a commended class; and one is led to wonder what the produce of such will be if their owners persevere in keeping such specimens for the stud.

Class 11 comprised the mares of the same sort. Mr. Crowe's Smart was first, a place mostly occupied by this animal. "Very, very good" may be written against her in any company anywhere. Low, long, and wide; sound, and a good mover, she claims the honour of being dam to the neat and true-made chestnut which took second among the 2-year-old fillies. The second prize goes to the great roan belonging to Mr. Street. Here we have more of the loaded hips, the deep mid-rib, and the tendency to low back, but in a modified degree, with much to commend and undoubted utility. The third prize was a question between the leggy brown, with the closely-ribbed, strong-built carcass, and the small but neat bay shown by Mr. Prees. Size decided the case in favour of Mr. Lamb's mare, against the protested appeals of one of the Judges for the low and long one. As a whole, the brood mares, with two exceptions, were a very plain set; and after the first and second were drawn out, the others were a very long way below them. The 2-year-old fillies were better. The big bay daughter of Honest Tom, shown by Mr. Purser, was a show-mare all over; quite the big stamp, but good looking, of good quality and grand action. It is no light point in her favour to have beaten Mr. Crowe's No. 151, already mentioned, an animal which has the credit of winning at all the Eastern Counties meetings this year. It should here be mentioned that two exceedingly clever well-spread mares, Nos. 154 and 155, were both put out of all chance by their curby hocks. On Mr. Brown's filly the verdict must be—"bred so," inasmuch as her own sister in the yearling class, a particularly fine filly, was sent away on the same account.

The Clydesdales were not a very numerous lot. The old horse class gave us a sight of that particularly true-made, handsome model of a cart-horse, Young Lofty. As a specimen of the pure Clydesdale, every breeder should get a sight of this animal. As a model to be held in the eye, he is a type for the breeder of any kind of agricultural horse in the world. He is the property of Mr. Tomlinson of Rugeley, who is certainly under a great misfortune in having such a horse excluded from the prize list, on account of his roaring. How far such a malady may be atoned for by other excellences, is matter worth consideration—not a practice easily defended in theory we allow—but if ever there was a temptation to ignore the *hereditary* nature of disease, it would be in a case like this. The Judge's duty is more plainly marked out, and we decided not to sanction the principle of admitting to the

honours of the prize list any animal so afflicted. The grey we had to fall back upon, was by no means an unworthy representative of his class. The dappled grey is not very common among the Clydesdales, although quite pure-bred specimens are to be found of that colour. Mr. Orange's horse has quite the characteristic marks of the breed: the two good ends—the short leg and somewhat drooping back with the grand action and great substance were all there. No. 31. The handsome black with his straight underline (another decided breed-mark) had to be discarded, and the third prize went to a small bay with very little of the grand about him.

Among the Clydesdale mares was Mr. Statter's very, very good Mrs. Muir, in every way a fit representative of her class. The 2-year-old classes of stallions and mares, require no particular notice. The exhibitor of No. 160, it is to be hoped, has learned from the Cardiff meeting what a Clydesdale is—a more miserable applicant for a prize card was never led out in earnest.

Of the Suffolk Classes it may be said they were very short in numbers and not surpassing in merit. The first-prize stallion has been a winner at the Royal once before. He is a shade darker than the orthodox colour, has a sourish head and his fore-legs are not well placed and are not particularly firm under his ponderous carcass. His walk, however, is first-rate and his deep carcass looks like a good constitution. His owner—Mr. Boby—won the prize when the Society held its meeting at Bury St. Edmund's with the sire of his winner at Cardiff. He is also successful in the 2-year-old class with a son of Royal Prince—a somewhat unique instance of one breeder winning with three generations of the same animal.

Among the Suffolk brood mares is Mr. Capon's Gyp, an animal with great development of muscle, but light in bone, very handsome and very active, but her foal gives little promise of bringing back to her owner much of the cost of the dam. A somewhat notable history attaches to this mare. She is one of twenty-three, which, in a *bonâ-fide* sale of a deceased tenant-farmer's stock last October, averaged over 100*l.* each. The sale was a large one, but an average of 100*l.* for such a number speaks of the repute the breed has in its own district. Two of the mares—of which Gyp was one—fetched upwards of 600*l.* Both were bought by tenant-farmers.

One of the most noticeable classes brought into the ring was that for pairs of agricultural horses. Among these were some very extraordinary animals; but the best, the handsomest, the most valuable, would have been more at home on the stones of London, the Docks at Liverpool or in the streets of Manchester than in any farm in any district. The substitution of the word "draught" for "agricultural" would have made the Judges' course a more clear one. Another difficulty was the ill-assortment of the "pairs." Of those to which the awards were attached, not two were of a colour or of a similar character. The white-legged chestnut—a perfect dray horse in himself—had a partner quite of another style and the magnificent grey mare had for her companion a narrow-chested blue-grey horse, with not much to recommend him but his size. The black mare in the "reserved number" was good all round except in the quality of her legs. Such a state borders on disease. Here was neither hair nor quality, and only those who have had horses' legs in such a state, can realise the trouble they ultimately cause. As purely agricultural horses, the pair of bays 105 and 110 were perhaps quite worth notice, but the sensational element of extraordinary size and extraordinary action, took the awards elsewhere.

The underground pair were but a couple of useful carriers'-cart animals, what may be the precise qualification for miners' cattle, beyond being below a certain height, is not quite apparent, but as there was but one competition for the prize, the Judges had no difficulty in deciding the question.

**The Report from the Riding-Horse Judges is also very**

comprehensive, and the argument over every class so fully entered upon, that it might be left to speak for itself. Nevertheless, the Report opens, as it were, with an apology for the award in the first class brought out, that is of thorough-bred stallions—"the three Judges simultaneously expressed their dislike to Laughing Stock." Remarkably enough, when this same horse took the first prize in the same class at Newcastle-on-Tyne in 1864, the decision in his favour was also accompanied by some disparaging commentary on the part of the judges, who declared that, "with the exception of Gamester, the class was a bad one."—Gamester being put third from a lack of showy action. Since then Laughing Stock's career at the Society's Meetings has been somewhat chequered: he was third in 1862 to Carbineer first and Motley second; he was second in 1870 to Knowsley first, and with Sincerity third; and in 1871 he was the reserve number, or fourth, to Sincerity first, Blinkhoolie second, and Suffolk third: while Suffolk was never noticed at Cardiff. Like Sincerity, who was also from the Carlisle district, Laughing Stock has hosts of friends and foes, and, although he now stands on the lists as the only horse who has twice won the thorough-bred premium of the Society, it is admitted that on both these occasions the competition was indifferent. In truth, with the exception of Christmas Carol, a really nice bloodlike horse, with his hind legs beautifully placed, and his old opponent Suffolk, there was nothing to "take much account of" at Cardiff.

The Judges, indeed, report pretty generally against the quality of what they found here; although it sounds odd to hear them say that, so indifferent were all the other heavy-weight hunters that "Iris had to be put second." I have seen in a really great show of hunters in Yorkshire Iris placed not only first in his class, but further proclaimed to be the winner of the Champion Cup—that is, to be the best of all the hunting-horses on the ground. Again, it is not so long since that I saw him knocked down at Tattersall's for, if I remember right, over 400 guineas, in itself "something of a character," particularly for so well known and used a horse. But a resolute nag like Iris to show properly requires a resolute man on his back, and when before the Judges he did not look to be half ridden. It will be seen, moreover, that a number of objections are urged against him; but, after all he has done, to be *forced*, as it were, into a second place in such a class, is, at least, a very remarkable illustration of how Judges differ. They have been some time in finding out "his bad forelegs, his harness forehead, and his hard mouth."

The Report embodies, if not a suggestion, a question for further consideration, as touching the award in the class of brood

mares for breeding hunters, where the first prize went to a thoroughbred one, whose present purpose is clearly breeding not hunters, but race-horses. By Newminster, out of the famous Fairwater, this prize hunting mare had a foal by Saunterer at her side, who is not very likely to face a fence, if he be only good enough to train as a race-horse. A hunter, however, in these times can scarcely be too well bred, and such an incident has not been one of frequent occurrence. It might be, in fact, as it has been urged, that the prize thoroughbred horses may be too good or of too high a class for the Society's object; but any such objection has been very exceptional, as most of these horses have come fairly within the farmer's reach. The tendency which I would the rather guard against from selecting a mare like Fairminster is, that farmers should be induced to try their hands at breeding thoroughbred yearlings for sale—just now about the most unsaleable stock in the market; at any rate from a farmer's hands. There have been numbers sent back this summer without a customer, and even the late Mr. Blenkinsop's last sale in July of 43 lots of yearlings at an average of 117 guineas each, must have been a losing business. The Society has for some time past been putting people into the right and only way of breeding a hunter, that is, by the use of the thoroughbred stallion with any likely mare a man may happen to have; but beyond this it would be better not to extend the lesson.

If the Welsh ponies were neither so numerous nor so clever as we had expected to see them, it does not altogether follow that they are deteriorating, or that the sort is going out of use. One of the best horse authorities in Glamorganshire told me that the Welsh farmers were scarcely educated up to the show standard, and that many better things might be picked up about the lanes and little homesteads than were entered for Cardiff. And this would possibly apply not merely to the ponies and galloways, but equally to the other Welsh breeds of stock. Herewith is the Report of the Riding-Horse Judges:—

Class 7. *Thoroughbred Stallions*.—The general inferiority of this class may be best described by the fact of all the three Judges simultaneously expressing their dislike to Laughing Stock the moment he entered the ring; and yet so more or less faulty were all the rest, that Laughing Stock after all came to the front. The fact is, action and soundness *will* be served in a showyard as well as elsewhere, and Laughing Stock, with all the faults of his Touchstone shoulders and small hocks, is a fine goer, and has more substance when measured than a casual observer would think; and he is certainly the sire of many showyard winners, for instance, one of the best (No. 202) to-day. The second-prize horse, Christmas Carol, has a deal of substance and general good about him, but his shoulders, like his sire's, are not quite right; his loins want muscle, and his hind-legs are full far behind him, and he appears somewhat irritable. The third prize, Reinfrid, has faulty fore-legs and is

too high; but he has great power behind, with all the Newminster quality, and more than their usual bone; is of a good colour, and in many respects a useful country stallion. The lightness of bone (especially behind) of Ely, who should not have stooped to such small game, the same fault amounting almost to a deformity in Suffolk, the terribly twisted and light fore-legs of Nine Elms, the small feet and want of action of Wild Charlie, the faulty hocks of Harcourt, and the want of power and energy of Rallywood, put them all more or less out of court "for getting hunters."

Class 8. *For getting Hackneys*.—Only poorly represented; the winner (No. 58), Mr. Mason's Norfolk Hero, was something of the sort wanted, but he has very stilty fore-legs, light ribs, and his action is not up to the Norfolk standard. The second, Mr. Lockhart's Dick Turpin, though neat and quick, has scarcely the bone and "character" necessary for a sire; and the third, Mr. Langley's grey Telegram, went with a straight knee and wide behind. The others were very indifferent.

Class 9. *Pony Stallions under 14 hands*.—At least one good-looking one in the three entries—Mr. Roundell's Sir George, and he goes as well as he looks, and is quite the sort to produce nice ponies. The second, Mr. Brewer's Blue Pill, is more of a racing pony, and the third, a common weed.

Class 10. *Pony Stallions under 13 hands*.—This class contained a couple quite worthy of notice, Lord Bute's Cymro (first), and Mr. Doyle's Tramp (second). The first, a light chestnut with flaxen mane and tail, with good power, though short of action, will leave his mark amongst the ponies of the district.

Class 14. *Mares for breeding Hunters*.—In this class was a very fine thoroughbred mare, Mr. Cartwright's Fairminster, so good it was impossible to pass her over, though it is a question whether it is quite fair to exhibitors of strong half-bred hunting mares that thoroughbred mares should be allowed to compete with them; and whether the Society should not now include them in a separate class, as the Royal Irish Society does. The second prize, Mr. Fox's Pink, and the third, Mr. Robinson's Go-a-head, are able competitors, and will be always hard to beat. Mr. William's Alice (R. No.), Mr. Powell's (commended) Chit Chat mare, and Lady Emily, were all nice mares, and this class was decidedly good.

Class 15. *Mares for breeding Hackneys*.—A bad class, winners excepted. Mr. Sherratt's Polly (first), was as neat a type of the hackney as need be. The second, Mr. Watts' Rosy Morn, was more of the thoroughbred stamp, but short-legged and good of her sort; while the only one that could be found good enough for the third was an old-fashioned grey, useful enough but with forward shoulders.

Class 16. *Pony Mares under 14 hands*.—These, though small in numbers, were good in quality, and the Judges commended the whole class. Mr. Coale's Kitty (first) would have been a real nice one had she a little more before the saddle; and the second, Mr. Worthington's Polly, only wanted a little more substance. This little class was quite the best of the day.

Class 17. *Pony Mares under 13 hands*.—Here were two or three clever little mares, especially Mr. Allen's little chestnut (first), that looked like carrying a boy with hounds.

Class 18. *Welsh Ponies under 13 hands*.—A nice class; and the three chestnuts that came to the front, Mr. Thomas's Minnie (first), Mr. Bower's Dandy (second), and Mr. Allen's Kitty (R. No.), were all well worthy of notice, as indeed were several others in this class.

Class 22. *Hunters up to 15 stone*.—This class was wretchedly bad. The winner, Mr. Jones's br. g., a second-class horse, was tied below the knees; and the second, Mr. Thomas's over-lucky Iris, found scant favour in the eyes of the Judges here; who did not think a stale horse near 16·3, with bad fore-legs and a harness fore-hand, a hard mouth and a conspicuous speedy-cut,

just what a heavy man's hunter should be, whatever the merits of his hind action, which is certainly good enough. However, so indifferent were all the others, that he had to be put second. Major Ballard's Redwing (the third), went as badly as from her formation she might be expected to; but there was nothing better.

Class 23. *Hunters up to 12 stone.*—A rather better class; and the first, Mr. Darby's General Hood was not very far from what a light-weight hunter should be; and Mr. Howell's Lancer (second) was but little inferior. The third, Mr. Stacey's Bianconi, was a neat hard-looking little harrier-horse. Most of the others had the too common fault of want of bone, without which even 12 stone is not to be carried long.

Class 24. *Hunters 4 years old.*—Always an interesting class; but though this looked well at first sight, it did not contain many that bore a close inspection. Mr. Cook's Admiral (first) is a little heavy forward, and quite high enough; but he has good limbs and joints—his hocks especially, and has nice manners in the ring. The second, Mr. Moffatt's Lady Graham, has all the action of Laughing Stock, her sire, with his fine blood, legs, and general quality; but she has not quite a decided "hunter" character about her, and her top is more that of a blood charger at present; but she is a fine mare and an improving one. The third, Mr. Thomas's Policeman, is a great loose colt requiring time, and his hind legs might be better. Mr. Teasdale's Theodore (R. No.) was only "useful"—a plain horse with straight shoulders.

Class 25. *Hunters 3 years old.*—A near thing between the first three, though three very different animals. The winner, Mr. Musgrove's Honeycomb, has all the bone and size of his sire Angelus, but, like him, he lacks action, and is not what may be called "all over a hunter;" his shoulders are loaded, and he promises to get too high; but with all this he is a fine colt. The second, Mr. Miller's Kettledrum colt, would have beaten him, but for his light fore-legs, for he is more hunting-like, and went beautifully; and the third, Mr. Allen's Cape Horn, by Cape Flyaway, is full of blood and quality, and must grow into a valuable horse. The rest in this class were very far behind the winners.

Class 26. *Hunters 2 years old.*—The winner, Mr. Miller's Singleton, was an exceedingly nice horse and a credit to his sire Carbineer, the Manchester Royal Prize winner. He is a nice size, well bred, and goes well; and if he does not make a hunter will be always worth a good deal "in another place." The second, a bay by Llandaff, has some hunting shape about him, and there were three or four rather promising young ones in this class.

Class 27. *Hunters 1 year old.*—Another Carbineer of Mr. Miller's was first, a nice mover, but lightish of bone; and the second has the same fault, and has no sire named in the catalogue. By the way, why are not the 3 and 4-year-olds stipulated to be by a thorough-bred sire, as well as the 1 and 2-year-olds?

Class 28. *Roadsters between 14 and 15 hands.*—Of this class the less said the better. Two or three were neatish blood hacks, the others the commonest of the common; and as the majority of the Judges held that the class was not intended for well-bred ones, and no better could be found amongst the commoners than Mr. Goddard's cream-coloured Dandy and Mr. Cook's grey General, the prizes went accordingly.

Class 29. *Cobs between 13 and 14 hands.*—This, the last class, was also the best; and of the twenty shown there were some eight or ten really good weight-carrying cobs. Mr. Stacey's Tommy Dodd (first) was quite a heavy gentleman's cob; and the second, a sturdy chestnut, was, despite his upright pasterns, a rare good stamp. With three or four exceptions, they all come from the neighbourhood, and it was pleasant to see such a characteristic class; though strange that in all the preceding ones (ponies and Mr. Cartwright's mare excepted), not one of the first prizes remained in Wales.

As a whole, the show of riding-horses was decidedly inferior.

CATTLE.

Notwithstanding the frequent gaps caused by the prevalence of the Foot-and-Mouth Disease, the competition here was pretty generally good, the chief exception being with the Devons, where, in many of the classes, the original entries did not extend to any numerical force, however excellent the individual animals. As usual, the centre of attraction, the great gossiping-ground of the day, was by the side of the Shorthorn ring, where, no question, the Agricultural Derby of the year is run off in the decisions over the all-aged bulls. Unfortunately the "neatest" bull of his time, Lord Exeter's Telemachus, was away in his box at Burghley, and hence a great deal of collateral interest evaporated. Indeed, beyond the Yorkshire-Irish St. Ringgan, there was no old bull of any particular repute in the class; and almost from the first the race looked to be reduced to a match between the two white 3-year-olds. When he first appeared this season, the improvement in Lord Irwin was very remarkable; he had thickened and spread into an admirably well-covered animal, with his good flesh capitably laid on; and beyond his small head, there was, when in the West of England show-ring, scarcely a fault to be found with Mr. Linton's bull, unless that he had "been done" a little too well by. And no doubt he had, for on meeting at Cardiff one of the Judges—not here in office—who assisted in putting Lord Irwin first at Dorchester, the same words were on both our lips at the same moment: "How he has gone off!" In truth, in the interim, the bull had had but little rest, having been out again and again in Essex and the North; and his travels had told, as might naturally have been expected. Mr. Outhwaite's white, on the contrary, showed out very gay and fresh; and the decision, though much discussed at the time, was confirmed when the two bulls met again in the week following at Spalding, as again at the Kelso show of the Highland Society, at Malton, at Newcastle-on-Tyne, and at Bolton. Last season, however, Lord Irwin beat Royal Windsor at the Society's show at Wolverhampton, and also at the York Meeting of the Yorkshire Society; though earlier in the year, and in very moderate company, Lord Irwin took no prize whatever at Guildford—Mr. Bowly, one of the Judges, with whom was Mr. Drewry, one of the Judges at Cardiff, officially recording Lord Irwin, in the West of England 'Journal,' as "a thick bull with good points, but with a head very deficient in character." At Wolverhampton, the Judges described Lord Irwin as "of excellent quality and character, and a massive, well-fleshed animal of great growth and much promise;" while they spoke to Royal Windsor as "of good quality and great

substance, with a level and evenly-covered back, capital loins, but not quite so good below." I am induced to quote thus much, as the Shorthorn Judges at Cardiff have rather epitomised their return than dwelt on the merits of any particular animal:—

Class 35. *All-Aged Bulls*.—We consider this class a very commendable one.

Class 36. *Two-year-old Bulls*.—This class we also think a very good one, and commend the whole of it.

Class 37. *Yearling Bulls*.—With the exception of the animals mentioned, we do not think this class calls for any further remark.

Class 38. *Bull Calves*.—This class we thought very highly of, as will be seen by our high commendations so liberally bestowed.

Class 39. *Cows*.—Many useful animals shown in this class, but we have on previous occasions seen better animals exhibited.

Class 40. *Heifers in-milk or in-calf*.—This is a very good one indeed. We had great difficulty in coming to a decision in many cases.

Class 41. *Yearling Heifers*.—The fact of our having mentioned so many animals in this class, sufficiently defines our opinion of it.

Class 42. *Heifer Calves*.—Some commendable animals in this class, but, on the whole, not a very strong one.

As I hold that nothing can be more wholesome, either as regards Judges or exhibitors, than fair criticism from outside, it may be only right to say here that the awards in the class of Shorthorn cows created a deal of discussion, not so much as regards the pretty milking-cow put first, who was altogether new to the South, as over some of the others which had just previously met, but under very different circumstances. Thus a merely commended cow at Dorchester was second at Cardiff; the first cow at Dorchester was merely commended at Cardiff; and the second at one meeting was third at the other; beating, and beaten by, in turn, Mr. Hewitt's and Mr. Stratton's cows. There was, as the Judges intimate, nothing of extraordinary excellence in the class; and merely moderate animals will continually turn the tables on each other. But the difference of opinion evinced in the placing of these three cows is rendered the more noticeable from one of the Judges having been in office at both meetings. The best 2-year-old bull, Mr. Lamb's Ignoramus, showed vast improvement since Wolverhampton; and even in better company might fairly have been promoted from third to first; while over the best 2-year-old heifer, a very admirable animal to the eye, there was something of a sensation. On the turf, a thorough-bred horse is virtually "no horse" unless his pedigree can be authenticated; and the same line must hold good with anything which goes to book for its belongings. Here, however, the age of Mr. Statter's heifer was stated to a day, together with her pedigree, although at the same time the entry admits that her breeder is unknown. There is no doubt that the description of pedigree stock—that is, cattle in contra-



distinction to horses—is a branch of the business of breeding at times very loosely regarded, and, as it seems to me, the supervision of entries should be more carefully taken up by the stewards, or others, previously to the catalogue being printed or the nomination passed. I have seen and heard of some curious cases of manufactured pedigrees during this last summer. In the Shorthorn show at Cardiff, however, the visitor came again and again on highly bred stock now flourishing about Bridgend, Tredegar, Newport, Chepstow, Cowbridge, Castletown, Llandilo, Pembroke, Newcastle Emlyn, and in other parts of Monmouthshire, Glamorganshire, Carmarthenshire, Pembrokeshire, and Cardiganshire. With such evidence as this before us, it is easy to see how the brindles are lost and the blacks are scarce.

Still the Shorthorn was not altogether omnipotent, as certainly “in places” the best illustration of any breed on the ground was that offered by the Herefords, and the Herefords are now doing so well in South Wales, that it is a nice question whether some of them will not eclipse the older established herds so carefully maintained in Herefordshire and Shropshire. It is not often that one man can show so strongly as Mr. Thomas, of St. Hilary, did with his grandly-grown heifers, uniting, as they do, scale with quality; and Usk, Cardiff, Welshpool, Brecon, Eglwysnunydd, and Cowbridge, again tell of how the Whitefaces have crept over from the confines of their own county. The Judges say that “probably four better cows of any breed than the four Herefords placed were never seen in the same class;” and I should almost be inclined to go on and say there probably never was a better class. There was the stamp of high breeding, and of the *same* breeding, about them all. Some might be more elegant and “finer” in their character than others, but there was that uniformity of points, markings, and “presence,” which should be the aim of every one who goes to perpetuate or improve a breed. In the companion class of Shorthorn cows, the speckled first, the delicate white second, or the broad, roomy, roan, commended, had really little in common; but almost any one of these Hereford cows might have been accepted as a model of her kind. Mr. Peren’s sweet cow was still first, as at Wolverhampton, where the Judges reported somewhat against her in this way: “Ivington Rose, one of the best Hereford cows ever seen, appears rather overfed for breeding purposes.” But since this was written, she has had one calf, and is in-calf again. I confess to have always had an especial fancy for Duchess of Bedford, here only the reserve; “but being near her calving-time, she was not even behind.” I shall not attempt further to anticipate or interfere with the Judges’ own Report on the Herefords, wherein good reason for everything is given.

We consider the show of Herefords a very good one, both as regards numbers and quality; more than could have been expected, considering the large extent to which the Foot-and-Mouth Disease prevailed in Herefordshire and the adjoining counties. Our duties commenced with—

Class 43. *Bulls*.—We awarded the first prize to No. 464, Bachelor: he is an excellent specimen, and only wants a good head to make him perfection. His son, Provost, No. 466, took second prize. With good character and substance, he combines much of his sire's symmetry and excellent flesh. Third prize, No. 465, Stout: a massive well-shaped animal, with moderate hair and touch. The reserve, No. 468, Dulas, is very large; and No. 463, Standard Bearer, was commended, and is a good stock animal.

Class 44. First Prize, No. 477, Von Moltke, has a grand outline, with good character and flesh, and a straight and evenly-covered back; but he stands rather too close on his hind-legs. Second Prize, No. 474, Chanter, is a useful bull. A very moderate class.

Class 45. First Prize, No. 492, The Cheltenham Boy. Large framed, with quite first-class character, flesh and hair, capital ribs, broad back, and stands well on his legs; inclined to be rather gaudy over the loin. Second Prize, No. 483 Lord Battenhall: square, and straight on his legs; good back and sides; rather hard hair, and not quite good rump. Third Prize, No. 481, Prince Joachim: a striking one at a side view; very deep; ribs too straight to give a broad back; moderate character, and medium flesh. Reserved and commended, No. 486, Vespasian: a good stock animal.

Class 46. First Prize, No. 498, Cop Hall: a square, solid, and level grown animal, with good character and flesh. Second Prize, No. 502, Regulus: has a straight and good back, excellent flesh and character, but is now slightly deficient in depth of body. Reserve number, No. 495, Marquis of Lorne, is a very promising animal, but his points are not yet well developed; and the same may be said of Triumph 4th.

Class 47. *Cows*.—First Prize, No. 523, Ivington Rose, is a model of beauty, symmetry, substance, thick flesh, and high breeding. Second Prize, No. 518, Silk 2nd, is a small-framed one, and is remarkable for symmetry, substance, good character, and flesh. Third Prize, No. 525, Lady Milton: a grand cow, with an evenly covered back and sides; good flesh and character, but wants more width through chest and shoulders. Reserve number, No. 512, Duchess of Bedford 6th: has great substance, with excellent flesh and character; but being near her calving time, was not even behind. The whole of this class was highly commended, and the best class of their breed. Probably four better cows of any breed than the four placed were never seen in the same class.

Class 48. First Prize, No. 534, Sunflower, is a large and deep heifer, with great substance and level shape; good flesh and character. Second Prize, No. 531, Plum, is remarkably handsome; but on a small scale as compared with No. 534. Third Prize, No. 533, Lizzie 2nd, has capital fore-quarters and back; medium flesh and character, but too hollow behind the hip. Reserve number, No. 532, Countess: a good heifer, but not in her present condition so good in front as No. 533; she has not a good rump. This was a good class, and all were commended.

Class 49. First Prize, No. 543, Rosaline: remarkable for size, symmetry, and good quality. Second Prize, No. 542, Madeline: a large and good one. Third Prize, No. 537, Lady of the Teme: excellent flesh and character, but a defective hind-quarter. Reserve number, No. 544, Belle of the West: good character and flesh, but not equal in substance to the prize heifers. A good class, and all commended.

Class 50. First Prize, No. 553, Ruby: has good character; evenly covered and compact, but a rather small frame. Second Prize, No. 547, Lady Alice:

a very promising one, with good hair and quality, but deficient in her under points. She is, however, young, and will doubtless greatly improve. Reserve number and Highly Commended, No. 548, Queen of the Teme: a good heifer, but not equal in symmetry to the prize heifers. Nos. 556 and 557 were both highly commended. Several in this class were backward in condition, and consequently showed to disadvantage.

The Judges declare the Devons "in size, symmetry, and quality, to be closely approaching perfection;" but it is to be regretted that more of the breed were not shown. In fact but for Mr. Davy from Devonshire, Mr. Farthing from Somersetshire, and Mr. J. A. Smith from Dorsetshire, amongst whom all the first prizes were distributed, there would be no show of Devons. The Official Report is as brief as the entry. Mr. Davy's best bull in the all-aged class is written of "great merit;" Mr. Farthing's Master Harry, "very meritorious, and a particularly good animal," but his colour, a tawny or dirty-orange, is against him; and at Dorchester Master Harry was passed by with a mere commendation. Over the yearlings the two Judges could not agree, and, on an umpire being called in, the quality of the Flitton told in his favour, although it is doubtful whether he can ever grow up or furnish into as deep and square a bull as the other; and Mr. Davy's best bull-calf, Duke Flitton 9th, has been shipped by Mr. Cochrane for Canada.

The cows were declared to be "a particularly good class," of three only; and the heifers in-milk, running to but four or five, were generally commended as "a highly praiseworthy class;" while the yearling heifers were highly commended. The first prizes, however, in both these classes, were overdone in the way of preparation, and the yearling more particularly looks as if she could never "keep her figure." Indeed, so neat an animal as your true Devon can hardly be of perfect symmetry, with such gaudy patchy excrescences as some of the young stock were developing at Cardiff. A thorough-bred Devon should be, at his or her best, one of the truest and handsomest animals in creation. Considering how well the Devon steers show at Christmas, and how closely they have of late contested for the champion prizes of Islington and Birmingham, it is noticeable, if not quite explicable, how poor a front they offer at the summer shows of breeding stock.

The Devon Judges also undertook the other established breeds, reversing some previous awards over the Norfolk Polls in the bull-class, where there was "no animal good enough to reserve;" and reporting the cow-class with a Red Poll first, and a Longhorn second, to be "very badly represented;" while the heifers, with Lord Sondes' two Norfolks at the head of it, were "an indifferent class," although at Lynn the Polls were considered to have made

a very creditable show; but then the other breeds were not all Polls at Cardiff. Mr. Warren Evans's "Hereford family," bull, cow, and offspring, were "praiseworthy;" and over the dairy cattle exhibited in pairs the Judges offered no comment whatever to the awards which put Shorthorns first, Herefords second, Shorthorns third, and Ayrshires fourth. Any such reticence is the more to be regretted as this is a class, of all others, over which some explanations of the principles upon which the decisions were made would be useful as a lesson hereafter. If, as we read it here, highly-bred Shorthorns and Herefords are really better dairy cattle than Ayrshires, of course an important point is gained, as we so obtain the best beef and the most milk from the same animal—an object, the attainment of which so far has been very strongly disputed. Writing of Wolverhampton last year, Mr. Jacob Wilson said, "The class for dairy cattle has always appeared to me one of very questionable utility," as the judges at that Meeting clearly considered it a very difficult class to dispose of. A couple of ragged Alderneys or common Yorkshires would make no show in the ring against a pair of comely, thriving Shorthorns, or when put side by side with Ivington Rose and Duchess of Bedford; and if the class be continued it should be under more definite arrangements and instructions.

In the dairy cattle "proper" there was but a moderate entry of Jerseys, more particularly of Island-bred stock; and I should be inclined to account for this in some degree from the home-breeders having of late "sold out" some of their best animals at long prices. America has been an especially good customer, and Mr. Le Cornu, a well-known judge in these classes at our Meetings, has recently sold a two-year-old heifer for 100 guineas, the highest price ever realized in Jersey, although I have seen it equalled here. There could, indeed, be no greater contrast than that between the small delicate natives and Lord Chesham's great gaunt heifers, going back, I believe, to Mr. Dauncey's stock. The Judges endeavoured to hit a happy medium between the two; but it would have been well to have had their opinion as to the experiment of growing Jerseys to such a scale as is now occasionally seen. Moreover, there are indications of the Jerseys being overdone for show, and a Jersey heifer going fast to beef should surely be something of an anomaly. The Guernseys were more satisfactory; of finer quality, and more dairy character than those sent over but a few years since; as one of these yellow and white heifers looked more like a milker than anything on the ground. Subjoined is the Official Report on the Channel Island classes:—

There was an increase in the number of entries in these breeds of cattle as compared with the two former years, but, owing to the prevalence of the Foot-

and-Mouth Disease, the classes Nos. 59 and 60 (Jersey Bulls and Cows) were not well filled, and contained no animals of special merit, except a young bull belonging to Lord Chesham. In Class 61, Jersey heifers not exceeding three years old, the number of entries was twenty-three, and nearly the whole of the animals very promising for the dairy. The first prize was taken by Mr. Simpson with Queenie, a showy animal; the second by Mr. Gilby, for a good heifer bred in Jersey, while Mr. Rendle had the reserve number with a very bloodlike imported animal. The Guernsey cows and heifers were a lot of first-class animals, and well worthy the inspection of the public, and, perhaps, also deserved better premiums than the Judges were able to award; for, in Class 63, Mr. Rendle took the first prize with a grand cow, and, moreover, a great milker, although now near calving. The other animals throughout the class the Judges highly commended, as being also superior milkers; but the principal attraction seemed to lie with the Guernsey heifers, Class 64, numbering nine animals, almost every one a good specimen of the breed. The first prize, No. 657, was a very showlike heifer, with great milking properties, and as level as a Shorthorn, while the second prize heifer was a straight animal, and was closely run for the prize by a much older heifer of Mr. Rundle Watson's, No. 656. In the Guernsey class for bulls there was only one animal exhibited, and the Judges submit whether the single prize of 10*l.* would not be better employed in augmenting or giving third prizes to the other classes, as there are not a great number of herds in England requiring Guernsey bulls. In concluding this Report, we observe there are six prizes given for Jersey cattle, two of which were taken by Mr. Gilby for animals bred on the Island, and four by different gentlemen for animals bred in England. In the Guernseys there are five prizes given, and they were all awarded to Mr. Rendle and Mr. Le Page for imported animals.

I have seen the Clydesdales gathered together in Glasgow, the Suffolks spread all over that pleasant park at Ipswich; the long red line of Devons at Barnstaple; the white-faces blocking up the highways in Hereford; and we have all fresh in our memories the show of Shropshires at Wolverhampton, and of Oxfordshire Downs at Oxford. If these were befitting expositions of local strength and merit, then I cannot but think some general disappointment must have been felt over so short an array of native Welsh breeds as that got together at Cardiff. The Judges, however, who spoke on the authority of experience, would seem to have been better satisfied:—

We are of opinion that the cattle of these breeds were an attractive feature of the show, and we were much pleased with the uniformity of character they displayed; more especially those called Castle-Martin. Nearly every animal to which we awarded a prize possessed great merit, and well deserved its distinguished position. Many of them have well-shaped heads and horns, with prominent eyes, soft hair, and thick mellow skins, indicating a superb quality of beef and good feeding qualities. They are also short legged, having hardy constitutions, and a peculiar adaptation to the country they occupy. Some, only a few, had sour heads, small eyes, hard hair and skins.

A gentleman from the neighbourhood of Pembroke has favoured me with some notes on the properties of the black cattle of South Wales, which will come well here as an appendix to the Judges' brief Report:—

It is commonly said that our Blacks are derived from the same original stock as the Sussex, Devon, and Hereford cattle. As with other middle horned varieties, the quality of their milk is excellent; but, unlike some of them, the quantity is abundant. They are hardy, but slow in coming to maturity; good doers out of doors during winter as 2-year-olds, and coming fast when turned into good pastures the following summer: hence their popularity with graziers, and the great trade through dealers or middle-men, who take them from Wales to Barnet, and other large fairs.

A curly coat is liked, and the usual points of good loin, hide, well-set tail, &c., are thought much of. The horn is not attended to quite so assiduously as formerly; in fact the breed does not now receive half the consideration it had twenty years ago; probably, as you suggest, because the Shorthorn and Hereford cattle suit the rich farmer better. Crossing is carried on without any system whatever. Calves are reserved for bulls, regardless of every sound reason, except, perhaps, the probability of their dying through weakness if subjected to the usual Eastern operation; and the best heifers are, as a rule, sold fat to the butchers. We are now trying to get up a little enthusiasm in the matter, and the Agricultural Societies have subscribed between them 50*l.* towards some champion prizes for bulls, to be competed for at Carmarthen next September. A Herd-Book is also in contemplation, to include not only Castle-Martin, but also Anglesea Blacks, a rather heavier variety of the same breed.

#### SHEEP.

At the Gloucester meeting in 1853, and it is noticeable how useful a landmark this may be made in the history of the Society, an experiment, at the instance of the late Lord Ducie, was tried with a view to check the over-feeding of show stock. A jury of nine of the Judges, drawn by lot, were instructed to examine every animal previous to his coming before the Judges of his class; but no cattle or horses were rejected, and only two sheep and two pigs disqualified as unfit for breeding purposes. The Shorthorn Judges moreover, considered that "the regulation as to examination by jury had tended to lessen the number of good animals shown;" while Mr. Milward, the steward, reported that "the lower character of the show was mainly attributable to this regulation; it being well known that many of our first breeders refused to exhibit, not choosing to run the risk of their animals being disqualified for over-fatness."

I confess that I have ever regretted the failure of this great English principle of trial by jury, the more especially as a very prevalent abuse at this very time is the pampering of sheep for show or sale. One hears, from all sides, of rams taken at long prices, which have proved utterly or next to useless, of large proportions of barren ewes—there are more about this year than ever—and of course of mutton getting dearer and dearer. I stood by and heard an unsuccessful exhibitor at Cardiff, reproved by his own brother, in this way: "How could you expect to take any prizes, when you had not got your rams half fat enough!" and, no doubt, there were too many "gross" cases about to point such

an argument, where the sheep looked far more like "ornament than use." The veterinary inspector, Mr. Brown, on being appealed to, certainly declared against one sheep as "useless for breeding purposes," and this was the four-year-old Lincoln; the Judges' report running thus:—

Class 84. The shearling rams are not a good class.

Class 85. This we think a very good class, and generally commend it. Professor Brown's opinion of the sheep No. 870 was that he was useless for breeding purposes.

Class 86. We are of opinion that this class, though having but few entries, is one of very high character, the ewes taking the first prize being exceptionally good.

It is very clear that any reform in this way must be brought about through the Judges, who should act both as Judge and Jury. It is a wholesome sign, however, when a Judge is ready to follow up his own acts and deeds, and one of the freest buyers at the Thorpe Constantine sale of Leicesters was Mr. William Torr, one of the Judges at Cardiff, who gave the highest price of the day, 141 guineas, for a shearling. Signal as was Mr. Inge's success, this had already been presaged, as the champion ram, that is the best of all the sheep, at the Exeter Devon County Society, was one with a Constantine pedigree, and the best sheep at the Dorchester meeting traced to the same blood which has penetrated through Devon down to the Land's End where anything of "any good" is pretty sure to show "a bit of Leicester." Subjoined is Mr. Riley's Report:—

Class 77. Shearling rams.—The first prize, No. 725, was a grand sheep, good neck, firm loin, a most beautiful fleece, altogether the best specimen of a Leicester, I have seen for some time. No. 745, the second prize, a fine upstanding sheep, a little too long in the neck. No. 740, the third prize, a very nice sheep but rather faulty in his fleece. No. 742, the reserve number, same as 745. No. 732 the highly commended, a very good sheep, but stood badly on his ancles. With the exception of the first-prize sheep, the class was scarcely equal to what I have seen exhibited.

Class 78. No. 753, the first prize, a very good three-shear with a capital fleece, and good firm mutton. No. 762, the second prize, is also a very good three-shear. No. 754, the third prize, is a useful two-shear, good loin and firm mutton—the class as a whole good.

Class 79. No. 765, the first-prize pen, I thought superior to any I had seen exhibited for some years, the perfect type of a Leicester. No. 767, the second prize, were very good, though the fleece was not quite perfect. Both the other pens shown were very good.

Notwithstanding that many of the leading flock-masters still keep aloof, there was a better show than of late of Cotswolds, in which classes Mr. Thomas of St. Hilary, and other local breeders, gave good evidence of how well this variety of sheep is answering in South Wales. The report of the Judges on the Glamorgan-shire ewes is very satisfactory:

Class 80. Notwithstanding a somewhat heavy rump, we had no difficulty in awarding the first prize to No. 769. In this class there were 39 entries, 10 pens however were not filled; taken altogether there were many fair specimens of the breed. The 10 pens in class 81 were filled with good sheep; No. 810 being disqualified by the veterinary inspector, on account of his fore-legs having given way, could not be adjudicated a prize. In class 82, the ewes winning the first and second prizes were very matching, showing a uniformity of character which is much to be desired in a flock of sheep.

The Oxfordshire Downs, as they become the longer established, are also reaching nearer to this desideratum in a flock—uniformity of character; and, although there were only half-a-dozen exhibitors, the competition, saving with the ewes where Mr. Charles Howard's beautiful pen had a long lead, was generally very close, and I never saw Judges work harder. Perhaps of all the sheep exhibited at Cardiff, there were none, running them right through, which evinced more satisfactory signs of improvement and advancement towards a recognizable breed than the Oxfordshire Downs.

Of the Oxford Downs we would first say that in all the classes we found great merit. In class 88, in which there were 21 shearling rams shown, the first prize was awarded to a sheep of good character, and although not standing *quite* well on his hind-legs, we placed him before No. 887, as that sheep was somewhat deficient in leg of mutton and rump. In class 89 there were only 9 entries; but all were sheep of great merit, and the commendations awarded by us were not made without our being convinced that they were deserved. In class 90 there were only 3 entries, and, although all were sheep of merit, we had not much difficulty in making our awards.

Notwithstanding that Sir William Throckmorton was compelled, by Foot-and-Mouth Disease, to keep his entries at home, and the new Merton flock was of course not up to its previous strength, the Judges were enabled to report very highly of the Southdown show at Cardiff. It has struck me that some breeders have always gone too much for mere size, although inevitably at some sacrifice of that style and bloodlike appearance which should surely be the essential characteristics of the Southdown—*Small in size but great in value*, as is inscribed under the Southdowns on the Leicester Monument at Holkham. It is easy enough to obtain weight and spread by a mixture of other blood, but the breeders of old *true* sheep, like the Leicesters and Southdowns, should pride themselves on this point, even though their animals be termed "pretty" and "delicate" by critics who often long for and occasionally take a taste. At Cardiff it was good to see that the heaviest sheep were not put forward as the best. The first-prize shearling and the first-prize two-shear were quite admirable specimens of their breed, but we missed that beautiful pen of ewes—often the sight of the show—which the Duke would send in from Goodwood. People say, even with so wide



a range of upland, the park is sheep-sick, or that there is the want of an outlying farm for the flock—a subject which might provoke a useful paper for the 'Journal.' The Judges thus report on the Southdowns and other Short-wools:—

The class for Southdown shearlings was well represented, and many good animals were exhibited, and one of the largest classes we have found for many years. The first and second prizes were real specimens of the Southdown, of superior character and quality with good wool; the third prize being a very good sheep, but not quite equal in quality and touch. The reserve number was a sheep of great size, good in his fore-quarters, but not right about his head. The class for rams of any age was as good as we have ever seen, and it would be hard to particularize them one by one, and we had great difficulty to come to a decision; the competition being so close we commended the class generally. In the shearling ewes some beautiful pens were shown; the competition being very close, we here also generally commended the class. Taking the whole of the Southdowns, we consider we have not seen them so good for many years.

The Hampshires we have seen represented in larger numbers at many previous shows. The prize shearlings were good specimens of the breed; the first being of great size and good quality. In the class of any age, the winner was of good quality, and we had no difficulty in awarding him the prize. In the shearling ewes, the numbers were short; the first prize were a splendid pen of ewes, and would have held their own in any company.

In Dorsets the competition was very limited. The prize rams were nice specimens of their breed, and well got up. In the class for shearing ewes we had no difficulty in awarding the prizes. The reserve pen were of an immense size, but were quite out of condition and had lost their chance. The other pens wanted size, but were of a nice quality. On the whole, we consider these sheep classes over an average.

It could not be expected that the Shropshires would offer so grand a front as they did last year in their own capital; and, indeed, the difference between the two meetings was so marked as to give something of a dejected tone to the Judges' Report. The want of uniformity was more observable than ever, as it is scarcely possible to imagine any two sheep of the same breed to be so little alike in growth and character as the first and second prize shearlings; while even the first-prize pen of ewes did not match. It is probable that some of the otherwise best Shropshires were amongst those put aside by the Inspectors of Shearing; but, beyond this, a new rule of the Staffordshire Agricultural Society may have directly tended to so moderate an entry. By this, any stock, but stallions, exhibited at the show of the Royal Agricultural Society shall be ineligible to compete at the Staffordshire Meeting. No good, but eventually much harm, would promise to follow from such a course to the country Society; as every one knows, there can be no other such an advertisement for a really good animal as an appearance at the Royal Shows. If, however, the alteration be sound, it should necessarily be followed elsewhere, and Herefords exhibited at Cardiff be ineligible for the coming Autumn Meeting in Here-

ford, Devons disqualified for their own county Society, and Oxfordshire Downs stayed from doing anything more during the autumn in Oxfordshire or Bedfordshire. The bigger the show, either at home or abroad, the better it should be for the breeders, and any rule to keep out the best animals would hardly pass in a parish meeting. The Shropshire Judges thus report, and, in doing so, I am glad to see an authority like Mr. Henderson say a good word for the Cheviots, which looked to me in many ways very "likely" sheep for the district:—

"In the Shearling Ram Class we found a difficulty in selecting animals of that uniformity of type to which allusion has been previously made in the Royal 'Journal.' The first-prize sheep is a compact animal, but on a less scale than we could have desired, to have seen one occupying so prominent a position. The second and third prize animals were larger sheep, but neither of them possessing all the attributes we hoped to have met with. Amongst the aged rams were several good animals, but none requiring special notice at our hands. In the Shearling Ewe Classes, one breeder brought together a large number of sheep, which, we think, will make up for the deficiency which existed in the first class we have alluded to. Independently of the prize animals, we have much pleasure in highly commending four pens and in commending the whole of the class. We had very little competition in the other classes which we inspected (with the exception of the Cheviots, which were fairly represented), as there were not as many entries as prizes offered.

Of the few Welsh sheep exhibited, I have been enabled to gather some particulars as to the Radnors, almost the only kind of Welsh sheep, it would seem, now really cared for. They are probably a mixture of the *original* Shropshires and Cardigans; as within the memory of man the Radnor hill farmers have always gone to Clun Forest for their best rams, but in a few years' time no doubt their country will be inclosed, and the flocks come to show still more of a Shropshire cross. In the south-eastern districts of Radnorshire some improvement has been effected of late years through a sheep brought in from Herefordshire,—a cross or mixture of the old Ryeland with the Leicester and Cotswold. The Radnor is a short-legged hardy animal, with a grey or speckled face, the rams generally having horns, but not the ewes. They are light in their fore-quarters, where the wool is very fine, but hairy about the leg. The ewes are almost always sold off to breed fat lambs, for which they are well adapted, being excellent nurses. But if lamb should go out of fashion the Radnor makes capital mutton, of the true old flavour; as, beyond the shearling class, the Radnors sent to Cardiff were seldom under four, five, or six years old.

In concluding this notice of the sheep-classes the Society must be congratulated on the wholesome result which has attended the labours of the Shearing Inspectors. Flock-masters who at first declared that such a system could never be maintained, that they should not continue to exhibit if it were, and so forth, have

quickly fallen into the observance of rules thus inculcated, while their sheep stand as well as ever on the prize-list. I have the authority of Mr. Leeds, the Steward of Sheep, for saying that no duties could be more thoroughly or conscientiously discharged than those undertaken by the gentlemen who looked to the shearing, as there was not a sheep which escaped their examination, let this arrive however late upon the ground. Subjoined is their official return:—

The Inspectors of Shearing beg to report the following numbers as failing to comply with the regulations:—

Class	No.
Class 94 .. .. .	997
"   " .. .. .	998
"   95 .. .. .	1019
"   " .. .. .	1020
"   96 .. .. .	1036

All the disqualified sheep were Shropshires.

### PIGS.

Within the last few years, more particularly at Meetings in the South or the Midlands, some very noticeable improvement has been apparent in the breeding of the large white pigs. Your true Yorkshire pig was certainly an immense animal, but so terribly coarse as to be almost unsightly, if he did not promise to be yet more decidedly unpalatable. Mainly, as it would seem, through the efforts of the Messrs. Duckering, and their pupils, the Messrs. Howard, a far better quality has been obtained, at no material sacrifice of size. The large breed is still large enough for all useful purposes, and some good illustrations of this were shown at Cardiff. The small whites, or "Solways,"—and now all of a family at Salford—were still better; while Mr. Sexton is as strong in blacks as Mr. Eden in whites. The Judges, however, in their elaborate Report depend on the Berkshires, as being throughout the best represented breed, and it is remarkable that during the summer these pigs have been taking a great lead; and deservedly so, too, as for type, quality, frame, and coat, they are amongst the best-looking pigs out. The Report may be left to speak to their individual merits, at the same time it should be stated that some of the awards over the Berkshires were not liked, the first-prize sow being objected to as one of the plainest in the class; and there is some warranty for this adverse criticism in the fact that, when shown at Wolverhampton last year, she was never noticed. However, let us now hear the Judges in answer:—

We have great pleasure in making our Report of the Pig Classes for 1872, and consider them very good, more especially the Berkshires.

Class 3. Large White Boar.—Five entries, one absent. First, to No. 1104, a well-grown animal of excellent quality; second to No. 1107; reserve to No. 1105, a good old pig, but grown a little coarse and uneven, being now in his fifth year.

Class 112. Young Boars of same breed.—Eight entries, all shown, two disqualified; a moderate lot. No. 1110 the best; No. 1111 second, rather leggy, and short of hair; the rest of the class deficient in this respect.

Class 113. Breeding Sows of same breed.—Nine entries, three absent. First, No. 1118, a good sow, of great size and quality, closely run by No. 1123, a clean-grown pig, with nice hair. Reserve, 1122, rather coarser.

Class 114. Three Breeding Sows, under eight months.—Seven entries, one absent. First, No. 1132, a nice level pen, fair quality, rather short of hair; second, No. 1126, not so much growth, and badly matched; a remark which applies to the others in this class.

Class 115. Boars of a small white breed.—Five entries, all shown. First, No. 1134; second, No. 1133; reserve, No. 1135; all three showing capital hair and great merit, and making a very close contest.

Class 116. Young Boars of same breed.—Thirteen entries, five absent. First, No. 1140; second, 1141; a very moderate lot.

Class 117. Breeding Sows, small white breed.—Sixteen entries, three absent. First, No. 1155; second, No. 1157; reserve, No. 1163. Both first and second sows were suckling healthy litters, and the Council may be congratulated on the fact that cases of dry nursing were much less frequent than at many of the Society's former Shows, although the young pigs sent with No. 1167 in this class were of very doubtful parentage.

Class 118. Three Breeding Sows same breed.—Nine entries, two absent, one disqualified; a moderate class. First, No. 1174, a nice pen of matchy pigs, of fine quality, and good hair; second, No. 1175, too fat for breeding sows, patchy, and not so nearly matched as the first pen.

Class 119. Boars of a small black breed.—Seven entries, all shown. First, No. 1182; second, No. 1180; reserve, No. 1179. The whole class commended; but we were sorry to find the rule against blacking or oiling had been infringed in every case, to the detriment of the pigs themselves.

Class 120. Young Boar, same breed.—Four entries, one absent, one wrong class. First, No. 1186; second, No. 1185; no reserve; the only other entry being a poor sample of the Berkshire type; oil and blacking again.

Class 121. Breeding Sows, small black breed.—Seven entries, one absent. First, No. 1192; second, No. 1193. Two nice level sows with good heads. Reserve, No. 1188, a good sow; oil and blacking brigade again.

Class 122. Three Sow Pigs.—Two entries, one in wrong class. First, No. 1195, fairish pen; second withheld.

Class 123. Berkshire Boars above twelve months.—Fourteen entries, two absent. A very good class. First to No. 1208, a capital well-grown level pig, only just over the year, first-rate for his age; second, to No. 1199, another good pig, very wide and good head; reserve, No. 1209; No. 1207 highly commended, a very good pig.

Class 124. Berkshire Boars under twelve months.—Twenty-five entries, six absent; a very good class. First going to No. 1215, a good thick-fleshed pig, with nice hair and light offal; second to No. 1219, a very nice, evenly-made young pig of great promise; reserve, No. 1222, a good pig, but over fat, and several of the rest in this class had suffered from early forcing so much as greatly to impair their usefulness for breeding purposes.

Class 125. Breeding Sow, Berkshire.—Twenty-seven entries, nine absent. A splendid class, showing great quality in nearly every case, and requiring much labour to decide. First to No. 1261, a very grand sow, of great length, and in proper condition for breeding; second to No. 1249, a true Berkshire

sow, with splendid head, good symmetry, but rather light in the skin, and slightly deficient in hair. Reserve and very highly commended to No. 1264, very true, and of beautiful quality. Nos. 1250, 1251, 1253, highly commended; and several commendations, all very good.

Class 126. Three Breeding Sows under eight months.—Thirteen entries, four absent. First to No. 1269; second to No. 1270. Both very good, well-matched pens, with good hair. Reserve and highly commended, No. 1271; highly commended, 1272; very fair pens, but hardly matchy. Commended, No. 1266. Some of the pigs in this class showed the evil effects of early forcing.

Class 127. Boar, not eligible for any other class.—Seven entries, one absent. First, No. 1278, a very useful stamp, with good flesh, plenty of hair, and very light offal; second, No. 1283, a long way behind the first, the rest moderate in character.

Class 128. Breeding Sows.—Four entries, one absent. First to No. 1285. This sow, now in her sixth year, is as good and level as ever, which we consider much in her favour; she has plenty of size, nice hair, very light in the bone, and of undeniable quality; second, No. 1286, a thick useful sort, but deficient in her rump.

Class 129. Three Sow Pigs.—Four entries, one absent, one disqualified. First to No. 1291, a level pen, but of no great quality.

On the whole the white breeds were but poorly represented, as might have been expected, owing to distance from home, &c., whereas the Berkshire were handier, and were in great force, being both numerous and good.

To the Wolverhampton Report Mr. Jacob Wilson added "a word on dentition," when he cautioned exhibitors against a system "which, if persevered in, will assuredly bring down upon the offenders a well-merited punishment in future." As the following Report from the Veterinary Inspectors will show, this caution has scarcely had its due effect:—

The dentition of the undermentioned pens of pigs indicates that the animals are above the stated age, viz. :—No. 1115, No. 1116, No. 1173, No. 1293, and those in Pen 1292, are not only, in our opinion, of a greater age than that stated in the certificate, but that they are not of the same litter.

No. 1115 and 1116 were young boars of the large white breed, entered respectively at 8 months and 1 week, and 10 months and 2 weeks old; No. 1173 was a pen of small white breeding sows, said to be 7 months and 2 days old; and No. 1293 was a pen of three breeding sows of the middle breed, entered at 7 months and 3 weeks old. These four entries were all made by the same exhibitors; but No. 1292 stood in another name. Thus, in point of fact, only two exhibitors of pigs were disqualified.

In putting this report together, so far as has been possible, I have endeavoured to let the Judges speak for themselves; but it is to be regretted that in the case of the Shorthorn and Devon "Benches," more has not been made of the opportunity. The old school of Judge did not give "reasons," being, as he would say, quite satisfied if he satisfied himself; but there are generally points which a Judge may take up with advantage, not

necessarily by a mere comparison of this animal with that; but rather, perhaps, in a running review of those particular breeds over which he has been invited to act, and where, as a consequence, his authority is acknowledged.

---

XX.—*Report of the Senior Steward on the Exhibition and Trials of Implements at Cardiff.* By C. WREN HOSKYNs, Esq., M.P. (Senior Steward.)

SELDOM, if ever, in the history of the country meetings of the Royal Agricultural Society of England has an area of equal extent presented results of such interest or value as that part of the Show-yard occupied by the competing machinery at the Implement Trials this year at Cardiff, during the tempestuous week beginning on the 8th July. The heavy rainfall which occurred during several days of the trials, while it proved the patience and persevering labours of the Judges, added in no slight degree, by its effect on the condition of the grain and straw, to the severity of the test in the case of the chief competition—that of threshing-machines. The visitation was not altogether useless or inappropriate, as barn machinery, though not entirely exempt, rarely comes in for those vicissitudes which affect the trials of field implements by the many varieties of soil, condition, and weather in this climate.

The accompanying Report, from the pen of Mr. Roberts, is so full and descriptive that little could be added to its masterly and clear account of the results and the character of a series of protracted trials such as have not been exceeded, for accuracy or competitive severity, on any former occasion; and it is only due to the gentlemen acting as Judges for the Society on this occasion, to record the opinion of the Stewards, that more indefatigable labour could not have been given, or more discriminating pains taken, to discover the points of excellence in all the classes of machinery on trial. Of the Threshing-machines as a class, since the extended adaptation of the dressing and finishing apparatus, it is hardly too much to say that they have nearly reached the point of practical perfection; nor could this be easily denied of the engines driving them. The resolution of the Committee to have all the corn *re-threshed* met with equal acceptance and satisfaction at the hands both of Judges and Exhibitors, and this not least on the ground of its having almost superseded the long acknowledged evil of 'racing.' This work of re-threshing was performed by a machine, for the timely loan of which the thanks of the Society are due to Messrs. Ran-

somes, Sims, and Head. The trials of Elevators occasioned a long and lively competition. Of these somewhat cumbrous and costly articles it is an unlucky feature that the point of most importance in their action is commonly the weakest, viz., the clearing the straw at the point of delivery. In many instances this defect was observable at the Cardiff trials; and the cure of it presents a difficult, though it is hoped not an insoluble, problem. The least satisfactory trials upon the whole appeared to be those of the class of Seed-cleaning machines. Only one can be said to have performed fairly well.

It may be desirable to mention, on this occasion, one or two matters connected with the general arrangement of the yard, to which the notice of the Stewards was called, and on which they would venture to offer suggestions for the consideration of the Council.

It has become the practice to mark, with previous prizes, implements and machines presented for trial; this the Stewards think should, on grounds of free and fair competition, on absolute and present merit, be discontinued. Another practice is that of duplicating upon other articles in the stand (on the claim of identity or similarity of structure) the award of the Judges in favour of *a particular* article; this, on obvious grounds, both in the interest of purchasers, and otherwise, the Stewards venture to think should not in future be permitted.

Among the General Regulations, Rule 33 requires that each boiler, before working, should be provided with *two* safety-valves. About twenty-six engines for working machinery in motion were reported to have come in with only one. On the rule being pointed out, several exhibitors sent for extra valves. The rule in question is a comparatively recent, if not new one. To avoid infringement in such cases, it is suggested that it might, perhaps, be desirable that *new* rules should be printed in red ink, or otherwise specially indicated to the notice of exhibitors.

The attention of the Council will probably be called to the circumstance referred to at page 417 in Mr. Roberts's Report, of the (apparently) malicious injury attempted upon Messrs. Marshall's threshing-machine, by the forcible insertion of an iron crowbar up one of the sack-spouts. On this matter being reported, the Stewards ventured to offer a reward, on the part of the Society, in addition to that proposed by Messrs. Marshall (both were in vain), for the discovery of the offender. Injuries of this kind, though happily not frequent, have taken place in the Show-yard, on certain occasions, and might, perhaps, be rendered still more rare by a standing law of the Society, in substitution for the temporary decision of the Stewards, acting, as that does, only retrospectively, and at the risk of the success of

the malicious intent, by the possible defeat of the particular trial in each case.

The Senior Steward has only, in conclusion, to offer his cordial thanks to his colleagues for their efficient aid, especially during his own unavoidable absence on other duties from the trials in the Show-yard; and to unite with them in the unanimous expression of high acknowledgment of the skill and untiring labour with which, under some discouragements, the Society's Judges performed their duties at the Cardiff Meeting.

---

XXI.—*Report on the Trials of Implements at Cardiff.* By C. G. ROBERTS, of Haslemere, Surrey.

THERE is probably no spot in the British Islands where the need of an increased employment of machinery in agriculture is more clearly illustrated than the neighbourhood of Cardiff, this year chosen as the site of our great annual tournament.

In approaching the town by rail we travelled with a young farmer from the vicinity of Newport, whose twelve months' experience commenced with paying wages at 12s. a week, soon followed by a rise to 16s., and who yet complained that he could not find sufficient hands to secure his hay-crop, although willing to pay still higher rates. We can hardly be surprised at this when we remember that, at the beginning of this century, Cardiff, with a population of 2000, all told, was but a village attached to the port of Bristol, and that its recent rapid rise to a population of 60,000 souls has been simultaneous with much emigration from rural districts to foreign countries, as well as to the neighbouring centres of work in coal and iron. As so large a proportion of the urban population were once labouring in the fields, it is not merely an interesting, but a very serious question, how shall the work be properly carried on without them? The true answer must be that agriculture, injuriously affected by the more powerful attraction of commerce and manufactures, must recover her equilibrium by seizing every advantage that improved machinery affords, while she eagerly adopts those changes in the conduct of her business that commercial intelligence suggests.

The modern history of Cardiff, however, does not tell of a past that was, in all respects, better for farmers than the present, for men still living remember the time, some 45 years ago, when the ordinary price of meat in Cardiff was 2d. per lb., in 1840 it was 4d., while this year one of the most curious pieces of local news at the time of our visit was a public notice given by the



neighbouring iron-workers and colliers at Tredegar, that they would abstain altogether from meat until they could have it at 6*d.* per lb. Perhaps some of those who thus showed their ignorance of the laws that govern the prices of food may have subsequently learned, by a visit to the Show-yard, how the complexity and costliness of farm-work, resulting, among other causes, from the scarcity of labour, is barely balanced by the increased value of some of its products.

The first visit of the Society to Wales did not result in any such diminution in the number of implements shown as might have been anticipated from the distance of the chosen locality from the chief centres of their manufacture. It is true that the number of entries were fewer, but the visitor soon found it a matter of congratulation rather than regret that, while the agricultural articles were amply exhibited in all their varieties, a large proportion of those miscellaneous objects that have lately encumbered the ground were absent.

In the early days of the Society agricultural implements exhibited were so few that the visitor might find time to examine all, and yet have ample leisure to look at objects that contribute to the comfort and convenience of the farm-house, though not strictly agricultural in their use. Of late years there has been a wish, not merely to limit the number of miscellaneous articles, but to prevent the exhibition of more than one agricultural implement of the same construction by one maker, and even to prevent the admission of a duplicate, though shown by another exhibitor. The latter suggestion, made in the Oxford Report of 1870, would effectually shut out agents as exhibitors, and might perhaps in some cases exclude valuable exhibits. We think that there would be less objection to drawing a distinction between makers and agents, charging the latter the extra rate now required from the miscellaneous exhibitors.

One main object of our meeting is to give facilities to farmers for acquiring the earliest information of mechanical improvements. We also wish to give purchasers an opportunity of comparing similar implements from different factories, and generally to lessen the commercial distance between the maker and the purchaser. It would be far easier to discover and examine new implements if the number of entries were yet further reduced below the comparatively moderate number of 5843 that occupied about 40 acres in the Show-yard. A second improvement is also worthy of note; the stands were better grouped at Cardiff than we have seen them elsewhere, so that makers of similar classes of implements were usually found in close proximity.

Cathay's Park, kindly lent by the Marquess of Bute, within a minute's walk of the town, enclosed by high stone walls and sur-

rounded by a double belt of trees, with others scattered over its area, furnished all that one could wish for in a show-yard, and needed only the fine weather that prevailed during the second week to make it perfect. The heavy rains that fell during the previous week might have seriously interfered with the conduct of the trials, but for the ample and judicious arrangement of temporary barn and shedding that had been provided.

The following is the list of prizes offered, with the names of the Judges in each department:—

“ *Judges.*—F. J. Bramwell, C.E., 37, Great George Street, London, S.W.; W. Menelaus, C.E., Dowlais, Merthyr Tydvil.

“ CLASS I.—For the best Portable Steam-Engine (not self-moving),  
not exceeding 8-horse power .. .. . £40  
For the second best ditto .. .. . 20

“ *Judges.*—Major H. V. Grantham, West Keal Hall, Spilsby; John Hemsley, Shelton, Newark; John Hicken, Dunchurch, Rugby; J. W. Kimber, Tubney Warren, Abingdon.

“ CLASS II.—For the best combined Portable Threshing and Finishing Machine, to be worked by steam, and adapted to the preparation of corn for market .. .. . £40  
For the second best ditto .. .. . 20

“ CLASS III.—For the best combined Portable Threshing Machine, to be worked by steam, which has no corn-screen or other apparatus for sorting the grain for market .. 40  
For the second best ditto .. .. . 20

“ CLASS IV.—For the best Straw Elevator, to be worked by steam, in conjunction with a Threshing-Machine .. .. . 10  
For the second best ditto .. .. . 5

“ CLASS V.—For the best Straw or Hay Elevator, to be worked by horse-power .. .. . 10  
For the second best ditto .. .. . 5

“ *Judges.*—W. H. Clare, Twycross, Atherstone; F. Sherborn, Bedford, Middlesex.

“ CLASS VI.—For the best Seed Drawer .. .. . £10

“ CLASS VII.—For the best Corn-Dressing Machine .. .. . 15  
For the second best ditto .. .. . 10  
For the third best ditto .. .. . 5

“ CLASS VIII.—For the best Corn Screen .. .. . 10  
For the second best ditto .. .. . 5

“ *Judges.*—Henry Cantrell, Bayliss Court, Slough; Matthew Savidge, the Lodge Farm, Sarsden, Chipping Norton.

“ Miscellaneous Awards to Agricultural Articles not included in the quinquennial rotation .. .. . Ten Silver Medals.

“ In the class for which one prize only is offered, the Judges were empowered to divide it equally between two competing implements, if they considered them equal in merit.”

Two alterations were made in this allotment of work. It was found convenient to take the non-finishing machines in Class III.

Fig. 1.—Plan of the Trial-yard at Cardiff.

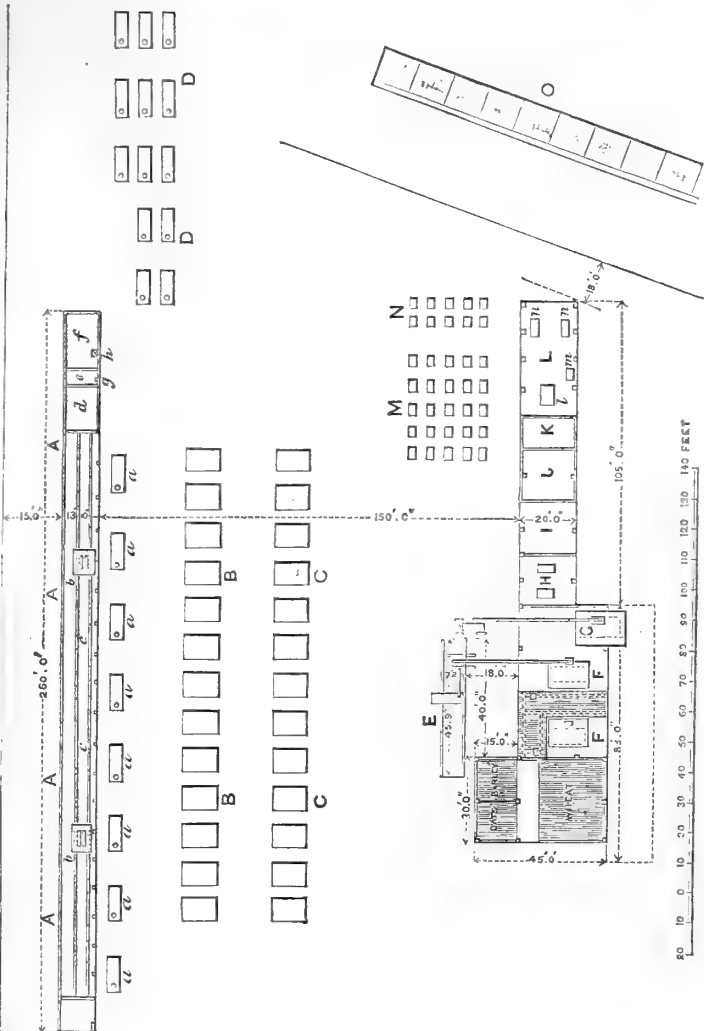

- A. Shed for testing portable engines.
- a. Portables in position for trial.
- b. Dynamometers.
- c. Dynamometer rails 4'-8½" gauge.
- d. Office.
- e. Oil-store.
- f. Coal-store.
- g. Scales.
- h. Weighing machine.
- B. Class II. Park of threshing machines with hauling-shafts at straw end.
- C. Class III. Park of threshing machines with hauling-shafts at straw end.
- D. Park of portable engines.

- E. Engine and dynamometer to test threshing machines.
- FF. Threshing machines.
- G. Machine for re-threshing straw.
- H. Dressing machines for corn threshed.
- I. Chaff-store.
- J. Corn-store.
- K. Office.
- L. Trial shed for hand-machines.
- l. Dynamometer.
- m. Weighing machine.
- n. Hand machines in position for trial.
- M. Class VII. Dressing machines.
- N. Class VIII. Corn screens.
- O. Horse-boxes.

before the finishing machines in Class II; and it soon became obvious that the number of entries in Classes II., III., IV., and V., would make it impossible for any single set of Judges, however willing, to complete the trials within the six days intended to be devoted to them. Major Grantham, and Messrs. Hemsley, Hicken, and Kimber therefore confined their attention to Classes II., III., and IV.; while Messrs. Cantrell and Savidge acted as Judges of the Horse-power Hay and Straw Elevators in Class V. as well as of the Miscellaneous articles.

The trials commenced on Monday the 8th July. The Stewards, Mr. Wren Hoskyns, M.P., Mr. W. J. Edmonds, Mr. T. C. Booth, and Mr. C. Whitehead, with Messrs. Eastons and Anderson, the consulting Engineers, and the full complement of Judges, mustered in good time. A brief inspection showed that the preliminary arrangements had been admirably carried out, the implements being drawn up in ranks in the order of trial, and the trial sheds arranged on the plan shown in Fig. 1, p. 407.

In this arrangement a great improvement had been made on that adopted at the Society's last trial of threshing machines,—at Bury in 1867. On that occasion a heavy thunderstorm interrupted the progress of the trials; the report recommended that in future the trial shed should be enlarged and space secured for stacking the sheaves under cover. Great advantage was derived from the adoption of this suggestion at Cardiff. In spite of frequent showers and the heavy continuous rain that poured down on Thursday and on Saturday afternoon, the Judges were enabled to continue their work throughout the week, none of the sheaves were wetted, and though all were alike made damp and harder to thresh from the condition of the atmosphere, this affected all competitors equally.

The temporary barn for wheat, barley, and oats is seen on the plan at the extreme left of the range of sheds; *a* is a section

Fig. 2.—Sections of Trial-sheds and Barn at Cardiff.

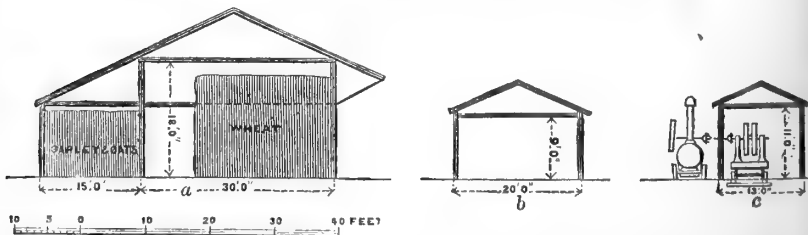

of this barn, and *b* a section of the corn-store sheds, &c. The floored shed in which the trials were conducted is to the right hand of the barn; it has a loft overhead for weighing and

storing the quantity of corn required for each machine, the part of the loft between the two machines being lowered to bring it level with their feeding boards (Fig. 3).

Fig. 3.—Section of Threshing-machine Shed.

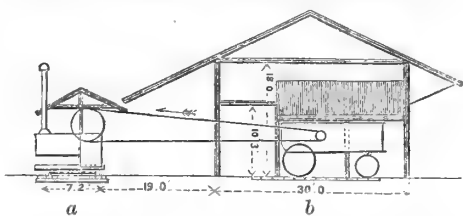

While the machine on one side of this loft or feeding stage was being tried, a second machine was brought into position on the other side. Upon a short tramway, covered by an awning in front of this part of the shed (Fig. 3, a, and Fig. 4), a strong wooden truck was drawn backward and forward by means of a winch and chain; this truck carried both the engine employed to drive the threshing machines, and the dynamometer used to indicate the exact amount of power absorbed in doing the work.

In the annexed sketch (Fig. 4) A is the engine—one of Messrs. Aveling and Porter's 8-horse power semi-fixed; B an intermediate

Fig. 4.—Sketch of the Engine-truck and winch used in the Trials of Threshing Machines.

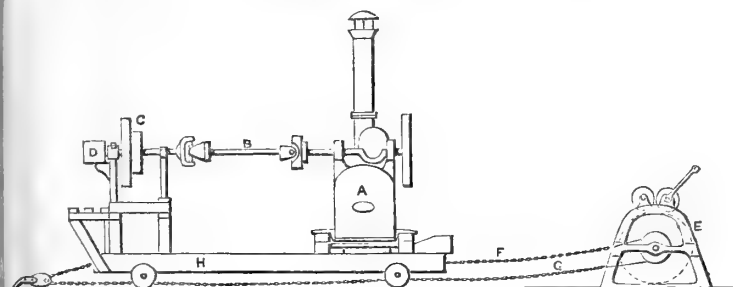

shafting; C the dynamometer; D the registering apparatus; E the winch; F the chain attached to the near end of the truck; G the chain from the further end of the truck, passing round the snatch-block to the winch; H is the truck. A belt from the pulley of the dynamometer drove the machine to be tested.

This arrangement is an improvement on that of the Bury trials, where the dynamometer was placed between the machine and the engine, and driven by a strap, instead of a shaft, from the latter; there were then three machines and two belts to be adjusted each time, and the dynamometer being placed on the ground, a special adjustment was required to keep the driving belt clear of

the travelling wheels of the thresher. This time the dynamometer was raised so that its pulley of 4 feet 6 inches diameter was at the ordinary height of the fly-wheel of an engine; revolving 130 times a minute, it delivered the belt at the regulation speed of 1884 feet a minute.

Another advance in method of trial was the re-threshing of all straw and cavings, thus ascertaining by direct experiment the exact quantity of corn left by the machine on trial, instead of leaving it to be estimated by the Judges. The machine for re-threshing was driven by a portable engine, and placed to the right of the machines on trial; it was necessary to put this machine forward to be in line with the straw as it came from the first threshing, and in future trials it will be desirable to extend the shed roof, as shown in Fig. 3, to protect this machine and the straw, before re-threshing, from the weather. An awning as an extension of the roof on the other side of the shed is also desirable to keep the driving belt dry, in place of the troublesome A shaped covering that had to be shifted by hand in wet weather. It should also be noted that the tramway would be better continued at the barn end, so that the dynamometer might be put far enough back to drive a pulley set on the left-hand side of the first machine. A slight increase in the size of the barn is the only further suggestion we would make for the improvement of a plan that left but little to be desired.

It was determined that the implements in Classes IV., V., VI. and VII. should be tried with the straw and corn resulting from the threshing trials, hence it was necessary to commence work with the threshing machines.

About 20 tons of wheat sheaves, the produce of 10 acres, had been previously stored in the shed, together with a few tons, respectively, of barley and oats. The quantity provided would have been amply sufficient if each trial had been as short as those at Bury St. Edmund's. After a short consultation it was resolved to test with larger quantities, and some delay was necessarily incurred in purchasing and carting a further supply. The whole of the wheat used was evidently from a very indifferent crop, of a white variety with a weak flaggy straw and much weed in the sheaf, while the grain was rather cold and tough. The quality of the sheaf corn was well suited to test the capabilities of the machines. It was certainly not an easy lot to thresh and dress well, and it showed the weak points of each machine far better than a crop uniformly good could have done. A necessary consequence of the foulness of the sheaves was that, although every precaution was taken to mix them thoroughly, some difference occurred in the quantities of grain yielded in different cases by the same weight of sheaf corn. These differences were noted by the Judges, and

ere was no difficulty in making a proper allowance for them, so at they never in the least affected the relative position of the mpetitors. There is no doubt that a good crop can be well rashed by the machines that deal successfully with a bad e.

In our Report we shall take the three trials in Class II. before the o trials in Class III., but as the trials were made in a different lder and some of our readers may wish to be reminded of what ey saw done on each day, we give a table of the week's work.

July 8, Monday .. .. .	1st trial of 4 machines in Class III.
„ 9, Tuesday .. .. .	{ 1st „ 11 „ „ III.
„ 10, Wednesday .. .. .	{ 1st „ 1 „ „ II.
„ 10, Wednesday .. .. .	{ 1st „ 11 „ „ II.
„ 11, Thursday (heavy rain all day)	{ 1st „ 3 „ „ II.
	{ 2nd „ 7 „ „ III.
„ 12, Friday .. .. .	{ 2nd „ 7 „ „ II.
„ 13, Saturday (heavy rain after noon)	{ 3rd „ 4 „ „ II.
July 15, Monday.—Trial of straw-elevators in Class IV.	

The numbers previously entered for trial were 20 in Class II. d 18 in Class III. ; some of these, however, did not put in an pearance, and the numbers actually tried were 15 in each ss. It may be noticed that all the competitors, except 3, tered in both classes. The exceptions being Tuxford and ns and Riches and Watts in Class II. only ; and the Reading on Works Company, who only entered in Class III.

The quantities of corn used in the trials were as follows :—

Class 2 .. 1st run, 20 cwts. of	{ Wheat sheaves to each machine, and 20 sheaves allowed for adjustment.
„ 2 .. 2nd „ 20 „	„ „ „ „
„ 2 .. 3rd „ 15 „	Barley loose, and 1 cwt. for adjustment.
„ 2 .. 4th „ 10 „	Oat sheaves, and 1 „
„ 3 .. 1st „ 10 „	{ Wheat sheaves, and 10 sheaves for adjustment.
„ 3 .. 2nd „ 20 „	{ Wheat sheaves, and 20 sheaves for adjustment.

The following order was observed in each trial. The machine ving been drawn by horse from its rank in the yard to the trial ed, was blocked in position and adjusted. It was then run pty until the driving-belt attained a steady speed of 1884 feet r minute. At a given signal the 20 trial sheaves were threshed t. The exhibitor then examined the different products while e Judges inspected the machine, he had thus a fair opportunity adjusting every part to deal with the material supplied. This ing done, the Judges, log-book in hand, stationed themselves that each might thoroughly observe one part of the work, not, wever, solely confining himself to this, but frequently inspec- ecting other parts, and duly jotting down, after each inspec-

tion of the straw, chaff, &c., the result in figures. Where several observations were taken, he subsequently gave in the average result of his different scores, the points of merit printed in Table I. being the average obtained by comparing the four different log-books. The machine was again run empty until the regulation speed of 1884 feet was obtained. Each exhibitor had six men to attend the machine, three of these cut the bands and handed the sheaves to the feeder, one attended to the corn, and one to the chaff and cavings. At a given signal, the first of the 20 cwts. of sheaves was handed from the stage on which it had been stored to the exhibitor's men as fast as they required them. The time of commencing was noted, as soon as the last of the loose corn was swept into the drum the time was again noted; the difference of these two observations is entered in column 17 as "Time occupied in Feeding." The straw as it came from the machine was taken to another part of the shed, as already stated, and rethreshed, the cavings were also rethreshed at the end of the run, the grain thus extracted was subsequently passed through a dressing machine, and the results are recorded in columns 26, 27, and 28, and determined the points of merit in column 32. Frequent observations were made of the straw as it came from the shakers in order to ascertain how much it was broken, and whether corn was left in the ear, from imperfect threshing, or simply mixed up loose in the straw from imperfect shaking; these observations determined the points in columns 33 and 38.

The quantity of the cavings was measured, and is recorded in column 29, and determined the points in column 34.

The points in columns 35, 36, and 37, were determined by frequent examinations of handfuls of the chaff taken at short intervals, and spread over the surface of a good sized table placed under the loft and between the machines. Small samples of the corn delivered were taken at intervals, the whole bulk delivered at each spout was weighed, and the quantities entered in columns 23 to 25; a subsequent examination of the corn determined the points recorded in columns 39 and 41. After the last sheaf had been put into the drum the machine continued to run till it ceased to deliver any of the products; a thorough examination was then made of the riddles, screen, hummeller, &c.; if any lodgment was found in these it reduced the points as given in column 40; this cleanness of delivery is a point of special importance in threshing out seed corn. The dynamometer was personally superintended throughout the trials by one of our consulting engineers, Mr. W. Anderson, who also examined the mechanical construction of the machines, and recorded his remarks in column 43. The speed of the driving-belt being







kept as near as possible to the regulation pace of 1884 feet per minute, the number of the revolutions of each drum (recorded in column 18) mainly depended upon the size of the drum rigger recorded in column 8. In column 6 we have the diameter of the drum in inches; multiplying this by  $3\frac{1}{7}$ , we ascertain the periphery of the drum in inches: thus in the second machine we have  $21 \times 3\frac{1}{7}$ , giving a periphery of 66 inches; this multiplied by the number of revolutions per minute in column 18 would give us the speed at which the periphery travels in *inches per minute*, and dividing this by 12 and 60 we get the rate in feet per second as given in column 19. The efficiency of the threshing proper, or the simple extraction of the corn from the ear, mainly depends upon the points indicated in columns 7 and 19, namely, the proximity of the concave to the drum, and the pace at which the drum-surface travels as it rubs or beats the corn against the concave. The concave being usually made in two parts, there are three points at which its distance from the drum may be adjusted—at the top, where the sheaf first enters, at the middle or junction of the two parts, and at the bottom, where the straw leaves the concave and passes on to the shakers, as shown in the section of the first-prize machine, Fig. 7, p. 422. During the trials the width of feed space was usually only measured at top, but in future trials it would be better to record the width at each point. The space should gradually contract from the top downwards. Thus in Marshall and Sons' machine, No. 5025, the width was  $\frac{1}{2}$  inch at top,  $\frac{3}{8}$  inch at middle, and  $\frac{3}{16}$  inch at bottom, when threshing wheat; and  $\frac{3}{4}$ ,  $\frac{1}{2}$ , and  $\frac{1}{4}$  inch respectively when threshing barley. The distance in every case was measured at the narrowest part, where the edge of the beater passed the projecting bar of the concave.

Some of the machines were fitted with an index upon the outside of the frame, showing at a glance the distance of the concave from the drum at each of these three points. We found the best of these indices to be the one on Messrs. Clayton and Shuttleworth's machine, and are strongly of opinion that every threshing machine should be similarly furnished, the farmer would then have no difficulty in telling whether the concave had been properly adjusted for its work.

In the speed of drum periphery (19) a striking uniformity of pace may be observed among the machines that did their work most efficiently; it will be found, in every case but two, to slightly exceed the rate of a mile a minute. One of the earliest historical allusions to the art of threshing speaks of a wheel turned about upon the corn; this was probably done at a rate of some 3 miles an hour; the greater rapidity of this steam-driven age does the same work at 20 times that pace.

Should any of our readers be not quite familiar with the expression "foot-pounds of work done" at the head of column 20, they may find a simple illustration useful. In raising water from a well the amount of work to be done depends upon two quantities—the number of pounds that the bucket of water weighs and the number of feet through which that weight has to be raised—200 lbs. raised from a well 100 feet deep would consume the same power as 100 lbs. raised 200 feet. By multiplying the feet by the pounds in each case, we obtain the same number, 20,000 foot-lbs. of work done. Now, in the case before us, the driving-belt running at the rate of 1884 feet per minute corresponds to the well-rope, and the net strain on the belt corresponds to the weight of the bucket of water; for instance, in Clayton and Shuttleworth's first run the average net strain on the belt, as proved by the dynamometer, was *about* 193 lbs., *i.e.* it was sufficient to have raised such a weight vertically. Now, 193 lbs. multiplied by 1884 feet would give us 363,612 foot-lbs. of work done per minute, the exact quantity being 363,351 foot-lbs.

Since the power of a horse is estimated as equal to 33,000 foot-lbs. of work per minute, the average horse-power used is obtained by dividing 363,351 by 33,000, and is entered in column 21 as 11.01. Since the machine ran for 18.8 minutes (column 17), the total work done was  $363,351 \times 18.8$ , or 6,836,000 foot-lbs. entered in column 20. Column 20 thus gives us the means of comparing the total power required by each machine for threshing 1 ton of sheaf-corn; but since all the trials were not made with 1 ton, only 15 cwt. of barley, and 10 cwt. of oats having been used in the third trial, we need a further calculation to enable us to compare accurately the power respectively required for threshing wheat, barley, and oats; this we obtain in column 22, where the result of dividing the foot-lbs. of work done (20) by the pounds of sheaf-corn threshed in each case (16) is entered. We here learn that for the threshing of each pound of sheaf-corn a power of from 2323 to 3137 foot-lbs. was required. In other words, we may say that if any quantity of corn were raised to a height of a little over half a mile, it would in falling produce a force which, if properly utilized, would suffice to thresh itself.

It may here be interesting to compare the power required for threshing a crop with the power expended in cultivating the soil for the same crop. Suppose the crop threshed to be one of 4 quarters per acre, the grain, at 63 lbs. per bushel, would weigh 2016 lbs., and the straw about twice as much, the sheaf-corn from one acre would weigh 6000 lbs., and the foot-lbs. necessary to thresh it would be about  $6000 \times 2500 = 15,000,000$

From the results of the steam-cultivating machinery at Wolverhampton in 1871, we learn that the soil moved weighed 190 tons per inch deep per acre; if all the work expended in ploughing 5 inches deep, harrowing, &c., were equal to two ploughings, then the foot-lbs. spent in cultivation per acre would be  $190 \text{ tons} \times 10 \text{ inches} \times 2240 \text{ lbs.} \times 20 \text{ foot-lbs.} = 85,120,000$  foot-lbs. per acre, or nearly 6 times as much as the threshing.

The two most important columns in the table are undoubtedly 22 and 42; the latter gives us the comparative perfection of the work done by each machine, the former shows the power which the machine absorbed in performing that work. The best machine (so far as the trial went, and apart from the question of strength and convenience of construction) would be the one that gained the highest points of merit at the smallest expense of power.

After each machine had finished its work it was run empty for 3 minutes; the power required to drive the empty machine is recorded in columns 12, 13, and 14.

Before proceeding to speak of the performance of the separate machines, it may be well to note the general information to be derived from an inspection of Table I.

Comparing columns 13 and 21, we observe that a very large proportion of the power employed is expended in driving the empty machine. This proportion varies from 52 per cent. in P. and H. P. Gibbons's machine to the extraordinary amount of more than 77 per cent. in Nalder and Nalder's machine. The lowest power required to drive any empty machine in this class exceeded  $6\frac{1}{2}$  horse-power.

Had there been time to do so, it would have been interesting to have ascertained by the dynamometer how this power was distributed throughout the machine; there would be little difficulty in doing so with the machine run empty, and as the drum is probably the only part that takes much more power when at work than when running idle, we might approximately have ascertained how the full power was divided. A great uncertainty upon this point appears to prevail among the makers. One of the chief makers estimates the work as absorbed thus—4-10ths by the drum, 4-10ths by the straw-shakers and caving-riddle, and 2-10ths by the other parts of the machine. If this estimate is correct for the machine when at work, we may conclude that fully one-half of the power required to drive the machine when empty is absorbed by the straw-shakers and caving-riddle, whose sole duty is to separate the short and long straws from the chaff and grain that have been mixed up with them after the latter has been extracted from the ear. Both shakers and riddle are usually driven by cranks; and these crank-

shafts are well known to be the parts of the machine most frequently requiring expensive repairs.

Any one who has examined the shaker-cranks that have done much work, will at once understand that much power must have been exerted to cause so much of the metal to be worn away in a comparatively short time. We find this to be especially noticeable where double following cranks are used. We shall have occasion to remark upon the advantages of the Brinsmead shakers when describing Messrs. Ransomes, Sims, and Head's machine; and we may here note that the form of box-shakers used by the other exhibitors, although many of them did their work thoroughly, does not seem so mechanically satisfactory as are the other parts of these complicated and highly-finished machines. Four or five wooden troughs or boxes, each about 10 feet long, and jointly occupying the whole breadth of the machine, jerked up and down by two long crank-shafts, or by one crank-shaft supplemented by rocking links, require for their movement much vertical space within the frame, and can hardly be considered an economical arrangement for effecting the separation of stray corns lying loose among the straw, although long usage has made us so familiar with the method that it seems almost rash to call in question such a time-honoured proceeding.

We find a very considerable difference in the time occupied (column 17). This point is determined by the judgment and activity of the man who feeds the drum; activity without good judgment in such work is most detrimental to the interest of the employer. So much depends upon the skill of the feeder that the Judges are unanimously of opinion that in future trials it would be well to have all the machines fed by one man. A good machine badly fed cannot do its work to perfection; and in some cases the feeder seemed to think that the only object to be desired was throwing the sheaves in as fast as possible. This was especially noticeable in the machine that made the quickest run, No. 4228. When will labourers understand that such machines, like animals, should be fed regularly? The food if bolted in either case will prove troublesome afterwards. It must be most aggravating to an exhibitor to find his chance of success thrown away by the stupid determination of a servant to perform the work as though speed were the only point of merit. The effect of irregular feeding was always shown on the dynamometer; with many of the machines the power required to drive them was at one moment three times as great as at the next. Thus, machines that on the average of the whole run used 10-horse power, would give a net strain frequently varying from 5 up to 15-horse power. We may be sure that in these trials the feeding was much better done than it usually is upon a farm, an efficient mechanical

arrangement is therefore greatly needed to ensure that even supply of corn to the drum upon which the regularity of all the subsequent processes in a great measure depends. Such a contrivance came under the notice of the Judges of Miscellaneous Implements, and will be noticed in its due place. Meanwhile, it may be noted that the bad effects of irregular feeding is to a certain extent lessened by making the periphery of the drum heavy—so that it shall do the work of a fly-wheel in equalizing the strain.

Although the result of re-threshing shows an important difference in the threshing by different machines, yet judged by hand and eye in the usual mode, all the straw would have been pronounced well threshed. It appears to have been impossible to thresh the straw clean without breaking it; for wherever the points in column 32 are high, those in column 38 will be found low.

In the first run the cleanest threshing and the highest total of points were obtained by Messrs. Clayton and Shuttleworth, while Messrs. Ransomes, Sims, and Head, and Messrs. Marshall, Sons, and Co., must be bracketed as a very good double-second; and Messrs. Ruston and Proctor are next in the race. These four, with three other competitors, were selected for a second trial, in which special pains were taken to ascertain the perfection of finish, or the efficiency of the dressing, and division of the corn in the machine. Two hundred pounds of the head-corn from each machine were passed through Mr. R. Boby's corn-dressing and greening machine, No. 3729. The result of this test was very satisfactory, for the "screenings" thus extracted were not in any case composed wholly of light grains; indeed, from the two machines at the head of Table II., the grain separated was simply small in the berry, but quite fit to be sold as head-corn. We have here the proof of a marked advance since this class of machines was tried at Bury in 1867, when the Report stated that "much tail-corn, chaff, &c., is mixed with the head-corn, or else a fair sample is obtained at the cost of allowing much good corn to go over with the tail." The division of Heads, Seconds, and Thirds, by Messrs. Clayton and Shuttleworth, and by Messrs. Marshall, Sons, and Co., was in each case satisfactory, the difference in the proportion being due to difference in the sheaf-corn. It is remarkable that the first-prize machine by Messrs. Marshall obtained the full number of points for perfection of finish in each of the four runs recorded. In one run, not recorded in the second trials, the separation by this machine was found imperfect, but on inspection of the screen at once showed that it had been injured, as there were three large indentations upon its surface, apparently made maliciously by thrusting a crowbar, or similar instrument, up one of the sack-spouts. A reward of 10*l.* offered

by the Society, with the addition of 20*l.* offered by the makers, failed to secure the detection of the perpetrator; but, whatever may have been his motive, it was defeated, as another trial was given as soon as the screen could be repaired. The results of this run are given in Table II. The screen was one of Rainforth's make, and the fact that, though only roughly knocked out into shape, it did its work perfectly in three subsequent runs, is an evidence of good construction, that may explain its popularity among the makers of threshing-machines. Column 11 shows us that 4 out of the 15 machines tried were fitted with Penney's screen, 3 with Nalder's, 3 with Rainforth's, 1 with Ransomes', and 1 with Tuxford's; the other 3 machines failed to separate the corn properly. The points for perfection of finishing (column 41) for the machines fitted with Penney's screen were respectively 5, 20, 5, and 0, giving an average of  $7\frac{1}{2}$ ; for 3 fitted with Nalder's screen, 15, 10 and 5, giving an average of 10; for 3 fitted with Rainforth's screen, 10, 0, and 20, giving an average of 10; for 1 fitted with Ransomes' screen, 12; for 1 fitted with Tuxford's screen, 10. The performance of a rotary screen depends as much on the regularity of its revolution as upon its fitness of construction: the revolution of the screen is affected by the revolution of the drum, and this, again, depends upon the regularity of the feeding and the weight of the drum; hence it is that we see so much difference in the performance of the same screen when used in different machines. Since Penney's and Rainforth's screens were entered by the makers as hand-worked screens for trial in Class VIII., it will be convenient to defer a notice of their construction till we report upon the trials in that class. The screens made by Nalder, Ransomes, and Tuxford, were not tried in Class VIII., but are noticed in the brief description of the threshing-machines made by each of these firms.

In the second run Messrs. Ransomes' stand 1st, Clayton's 2nd, Marshall's 3rd, and Ruston's 4th; but, adding together the points in the 1st and 2nd runs, the order will be

					Points.
Clayton	..	..	..	1st with	832
Ransomes	..	..	..	2nd „	825
Marshall	..	..	..	3rd „	811
Ruston	..	..	..	4th „	783

Each of these four machines on Saturday was submitted to a further trial with 15 cwts. of loose barley, an indifferent crop, with short straw, rather less than 18 inches long, and 10 cwts. of black Tartary oats, short in the straw, and apparently badly harvested being rather cold and tough (see Table III.). In threshing the barley the first three machines obtained very nearly the same total o



points, but with the oats a very considerable difference occurred; Messrs. Marshall, Sons, and Co., obtaining the very high score of 447, out of a possible total of 450, Messrs. Ransomes, Sims, and Head, getting 433, while Messrs. Clayton and Shuttleworth only obtained 414 points. A part of their deficiency is due to their having dispensed with the use of the screen, thus making only two, instead of three, divisions of the corn. But their loss is chiefly due to the choking of one of the sieves in the shoe of their second dressing apparatus. The two sieves had been placed in the first and third grooves, instead of the second and third; the consequence being that there was not sufficient space to receive the oats as they passed from the white-coater box. The choking of this sieve of course caused an accumulation of corn in the white-coater box and cup-elevators, and soon stopped the working of the machine. As soon as the cause of the hitch was discovered it was rectified without much loss of time, and the trial resumed. On taking a grand total of the four runs, the points made by each machine, and the average of foot-lbs. of work done for each pound of sheaf-corn, stood thus:—

	Total points of merit.	Average foot-lbs. per pound of sheaf-corn.
Messrs. Marshall, Sons, and Co. . .	1685	.. 2321
„ Ransomes, Sims, and Head	1685	.. 2715
„ Clayton and Shuttleworth..	1670	.. 2481
„ Ruston and Proctor . . . .	1623	.. 2719

The first prize of 40*l.* was awarded to No. 5025, Messrs. Marshall, Sons, and Co., of Gainsborough; the second prize, of 20*l.*, to No. 4658, Messrs. Ransomes, Sims, and Head, of Ipswich. No. 4943, Messrs Clayton and Shuttleworth, of Lincoln, was highly commended; No. 5014, Messrs. Ruston, Proctor, and Co., of Lincoln, was commended.

The general standard of work attained in Class II. may be reported as good; all the four machines selected for the final trial did their work admirably.

We will now briefly describe the differences of construction observable in the machines tried, and for convenience of description it may be well to classify them according to the general arrangement of their parts.

5025. *Marshall, Sons, and Co.*—In this machine we have a good example of the arrangement of parts adopted with only slight modifications by the great majority of makers; although in Gibbons' machine the external appearance is modified by placing both screen and corn-elevator outside the frame, there is hardly any important divergence from this type, except in the machines made at Norwich by Messrs. Holmes and Sons, and Messrs. Riches and Watts, and in the Ipswich machines made by Messrs. Ransomes, Sims, and Head. In the Norwich machines the drum is placed low, and the mixed grain and chaff are together elevated to the winnowing apparatus placed at the top of the

machine; in Ransomes' machine we find an open frame and a form of straw-shaker essentially differing from that used in all the other machines.

In describing the machines we shall frequently have occasion to speak of the back and front, the right and left sides, and, to prevent confusion, it will be well at starting to explain how these terms are used. In the accompanying illustration (Fig. 5) of Marshall's machine we call that part of the machine

Fig. 5.—View of Messrs. Marshall, Sons, and Co.'s Threshing Machine, showing the back and right side.

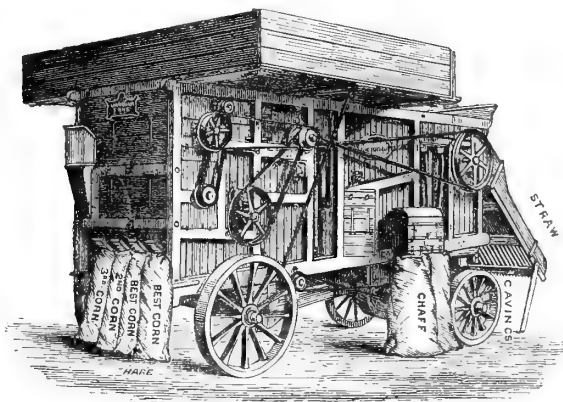

the front which in work is furthest away from the engine, and where the straw is invariably delivered; the back is the part facing the engine, where, in this instance, the corn is delivered into sacks; the side facing us, where the chaff is in this case delivered, we call the right; the unseen side, which has the rigger for the driving belt, we call the left side.

As the power is usually conveyed by means of friction-belts from the drum to the other parts of a threshing-machine, we have noted against each machine the number of belts (exclusive of the engine driving-belt) used on each side. The arrangement of these belts is not always the same in machines sent out by the same makers, but should be noted, as a bad arrangement may result in an unequal wearing of the bearings.

Fig. 6.—Illustrating the arrangement of a set-screw to the bearings on a drum-shaft.

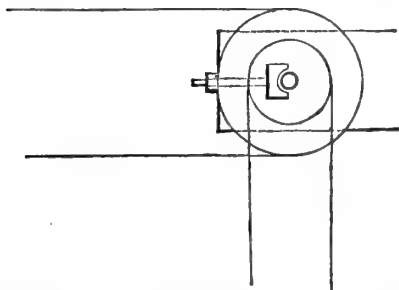

In one unimportant particular the illustration (Fig. 5) differs from the prize machine, since in the trial the chaff was delivered on the left side, but is here represented as delivered on the side shown in the drawing. On the right side three belts are driven from the drum-shaft, the strain of the two belts pulling backwards lessens the pressure produced by the belt pulling forwards, and the pressure by which the sheaf-corn, as it passes between the concave and the drum, tends to drive the latter upwards and forwards. This arrangement is good; the bearings of the drum-shaft on this right side will wear but little, and will not be liable to get hot. The arrangement of belts on the other end of the

drum-shaft is also good; there is only one minor belt on the drum-shaft, which, pulling downwards, partially counteracts the lifting pressure, while the belt from the engine counteracts the forward pressure of the sheaf; by a set-screw (Fig. 6) the brass bearing behind the shaft, as it wears, may be pushed forward, so that the position of the drum-shaft remains unaltered. Wherever the pressure on the bearing on one side of the drum differs in direction from the pressure on the bearings at the other end of the drum-shaft a set-screw should be used; in machines not so provided the position of the shaft in time becomes oblique, the brasses are worn unequally so that they cannot be reversed, and we may sometimes find an old machine that, from the misplacement of the drum-shaft, must be set obliquely to its work in order to keep the belts from slipping off the pulleys. We have called attention to the end attained by this set-screw as it was wanting in some of the machines in which the arrangement of the belts demanded some such contrivance.

In the machine before us we have 2 belts on the left side, one of them driven from the drum-shaft, and 5 belts, as shown in the cut, on the right side, 3 of them driven from the drum-shaft. Of the 2 straps on the left (unseen) side, one from the drum-shaft drives the shaft placed below the frame on which two sets of fans (F in Fig. 7) are fixed, the other strap is driven by the riddle-shaft and drives the corn-elevator ( $g^1$ ). Of the 3 straps on the right, driven from the drum-shaft, one, passing forward, drives the crank-shaft ( $b^1$ ) that moves the straw-shakers, another drives the smutter (H), and the third drives the crank-shaft for moving the caving-riddles (D) and the shog-board (C). Beneath the frame is seen the belt from the fan-shaft driving the chaff-elevator, and at the back the belt from the corn-elevator ( $g^1$ ) driving the rotary screen (J). The passage of the corn through the machine is also shown in the longitudinal section given in Fig. 7.

The drum is a skeleton-cylinder of wrought-iron, and consists of three rings keyed upon the central shaft, and bearing eight wrought-iron bars, upon which the beater-plates of mild steel are fastened. This drum, and the one exhibited by Messrs. Ransomes, were the only ones in which iron was substituted for the wooden bars which usually carry the beater-plates.

The concave is a wrought-iron grating embracing more than half the circumference of the drum, and is formed of bent iron wires and longitudinal iron bars. The bars (shown in the section, Fig. 7) are two inches apart, the wires are a quarter of an inch in diameter, with seven-sixteenths of an inch spaces.

Most of the grain and chaff beaten, or rather *rubbed*, out in the drum, falls through the concave, and is at once passed on to the riddle (D), the rest passes with the straw on to the shakers (B). The five shakers each ride upon the crank-shafts ( $b^1$  and  $b^2$ ), which make 160 revolutions per minute. The crank for each shaker differs from the one next to it, so that while one shaker is moving downwards and backwards, the shaker next to it is thrown upwards and forwards—the long straw is thus passed forwards with a series of jerks, while its progress is regulated by the two shutters suspended over the shakers which serve to hold the straw down and prevent the passage of flying grains. The loose corn and the cavings or broken pieces of straw fall through the lattice which covers the shakers on to the oscillating board (C), and are by it returned on to the caving-riddle (D). The oscillating board and the riddles are hung by wooden spring suspenders placed outside the frame, shown in Fig. 5, and are swung to and fro by connecting rods ( $d$  and  $d^1$  Fig. 6) from a crank-shaft which is placed above the hind-wheels of the machine, and makes 200 revolutions per minute. The caving-riddle is slightly inclined, and is made in four divisions or steps, pierced with cylindrical holes. When used for barley all the holes are three-quarters of an inch diameter; for wheat the holes are three-quarters of an inch in the two upper divisions and five-eighths of an inch in the two lower ones. The cavings pass over the riddle and are delivered on to the ground behind the straw. The corn and chaff fall

Fig. 7.—Longitudinal section of Messrs. Marshall, Sons, and Co.'s Threshing Machine, No. 5025.

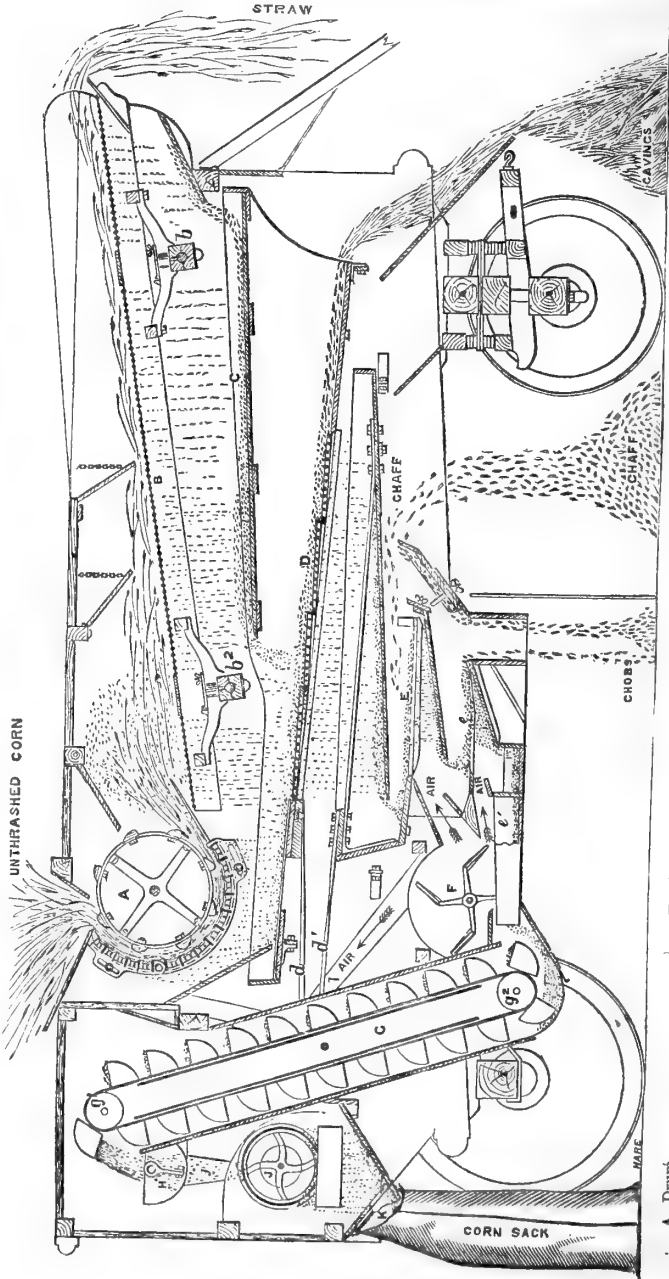

- A. Drum.
- B. Straw-shaker.
- C. Shog-board.
- D. Caving-triddle.
- E. Dresser.
- F. Fan.
- b<sup>1</sup>. Crank shafts.
- d. Connecting rods.
- e. Lower sieve.
- e<sup>1</sup>. Corn-shoot.
- G. Elevators.
- H. Smut-ter.
- I. Second blast.
- J. Rotary screen.
- K. Corn-spout.
- g<sup>1</sup>. Pulleys.
- g<sup>2</sup>. Spout leading to straw.

through the holes upon a fine wire net-work, which removes the small seeds; the cleansed chaff and corn are next conducted by a second shog-board to the sieve (E). The corn falls through the two sieves (E and e), and passes through the shoot (e') to the chamber at the bottom of the elevator (G). The fan (F), revolving 680 times per minute, directs two blasts of air against the under sides of sieves (E and e), and carries the chaff to a chamber not shown in the section, but which may be seen behind the chaff-bag in Fig. 5, page 420; from this chamber three revolving shovels toss up the chaff to the small hopper, from which it is delivered by spouts into large bags. The chobs—small pieces of imperfectly threshed ears—are separated from the corn by the first blast, and, striking against the sliding board, are delivered into a basket below, and thence removed by hand to be re-threshed.

Fig. 8.—End Elevation of Messrs. Marshall, Sons, and Co.'s Threshing Machine. No. 5025.

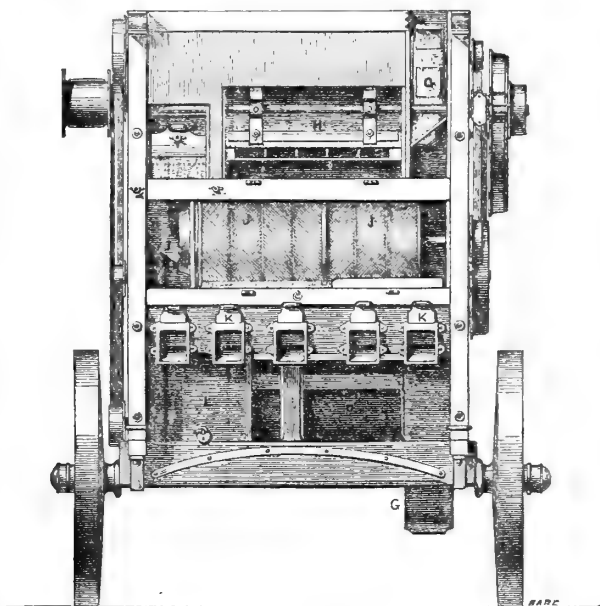

In threshing beans a trap-door at the bottom of the elevator case lets the beans out as they come from the shoot (e'); all other corn is carried up by the elevator-cups to the smutter (H), which breaks smut-balls and removes the awns from barley, and any *white coats* or closely adhering chaff from wheat. The smutter-case is a wire-mesh cylinder in a wooden frame; the smutter is a miniature threshing-drum, making 700 revolutions per minute, and furnished with three plain beaters arranged obliquely, so that they act as a screw, and drive the corn along the length of the cylinder, at the same time that they rub it against the wire-mesh, through which the dust passes, while the corn is rubbed bright in its transit. The amount of rubbing is regulated by a slide at the further end of the smutter-case; when this slide is nearly closed, the corn is retained a long time, and receives an extra amount of rubbing. The corn as it falls from the smutter is subjected to a second blast driven from

the fans up the wind-case (I); this blast carries the chaff, awns, and any remaining white coats back under the drum concave and on to the caving-riddle. The corn passes down the spout (*j*) into the rotary Rainforth's screen (J), which makes 40 revolutions per minute, and delivers the grain through spouts as best corn, seconds, and thirds. When the condition of the corn renders it undesirable to pass it through the second dressing-apparatus, the machine can be used as a single-blast machine by letting the corn, as soon as it is raised by the elevators, fall through a trap-door to the sack-spouts, instead of passing through the smutter and second dressing-machine. The frame of this machine is of oak, and the boarding over the top is continued as far as the outer end of the shakers. All the working parts, including the elevator, being fixed within the frame, are protected from the weather and from injury in travelling. A contrivance, peculiar to the machines shown by this firm, may be noticed in the shallow grooves turned upon the surface of the friction-pulleys. These grooves are two spiral threads starting from the flanges and meeting in the centre of the pulley. They have the effect of keeping the belt in the middle of the pulley. In all respects this is a well-constructed machine, but we should consider the addition of clear indices of the feeding spaces round the drum a very desirable improvement. Fig. 8 (p. 423) is an end elevation of this machine, in which the parts already named are marked with the same letters. A box for tools is shown at L.

4943. *Clayton and Shuttleworth.*—This machine has three belts on the left side, one of them from the drum-shaft increasing the strain from the engine-belt; and four belts on the right, the two driven from the drum-shaft balancing each other. The drum-spindle is of steel,  $1\frac{7}{8}$  inch in diameter, and is supported by an iron bracket, which gives a second bearing outside the rigger for the engine driving-belt. In spite of this double bearing, the great strain upon a shaft of such small diameter caused the outer bearing to run hot in the first trial. The general arrangement is similar to that of Marshall's machine, except that the corn-elevator is placed outside instead of inside the frame, and the second fan is not placed on the same shaft as the first fan under the frame, but is carried on the further end of the hummeller-shaft close to the sieve-frame of the second dresser. The second sieve-frame is moved without extra gearing by simply attaching it to the two sides of the caving riddle frame, which are prolonged for this purpose.

In this and in some other machines the two operations of hummelling, *i.e.* of removing the awns from barley, and of removing white coats and cleaning the grain by rubbing, are not performed in one apparatus; but the grain is first passed through the hummeller, a small cylinder in which revolves a shaft set with knives arranged so as to drive the corn forward while the awns are cut or chopped off; it then enters the white-coater, a cylinder of larger diameter, in which revolving beaters rub it against the outer case. A single revolving shaft carries an archimedian screw, the hummeller, the white-coater, and the second set of fans. The office of the archimedian screw is to receive the grain as it falls from the cup-elevators and pass it on to the hummeller.

The straw-shakers are carried on a single crank-shaft placed under the middle of their length. The outer ends of two of the shaker-boxes are on rocking links, their inner ends being free. The other three boxes are free at their outer ends, but their inner ends are held by a cross-bar, extending across the machine, and carried by two links. The bearings of the drum-spindle rest upon an iron casting. The caving-riddle is one of Humphries's patent.

Gray's Patent *Rolled Steel Beater Plates* are fastened by bolts to the wooden bars of the drum. These plates combine the hardness and durability of steel with the toughness of the malleable cast-iron plates previously used. Messrs. Clayton and Shuttleworth were the first to introduce a machine to finish grain for market, and they exhibited one at Lewes in 1852, before a prize had been

offered by the Society; they have long been noted for the excellent construction of their machines, and have recently introduced the trussed frame, a diagram of which is shown in Fig. 9.

Fig. 9.—Exterior view of Messrs. Clayton and Shuttleworth's Threshing-Machine. No. 4943.

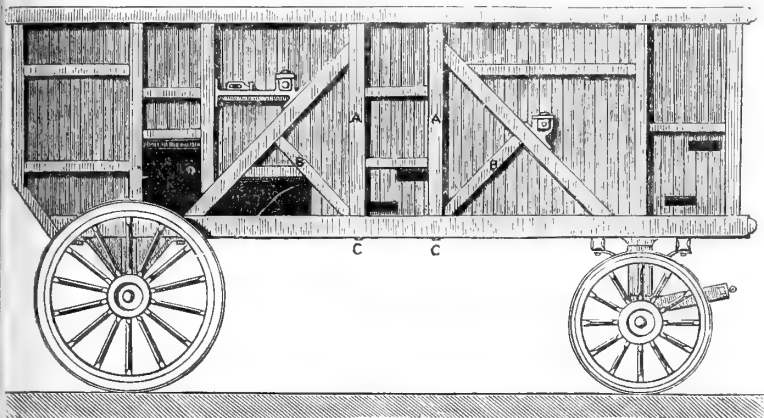

By this arrangement the side frame forms a very deep girder, taking its bearings directly upon the axles. The rigidity of the frame is a point of great importance, since it forms the foundation for all the moving parts of the machine.

The chaff was well bagged; and the feeding was done with admirable skill and judgment, the sheaves having been well spread, and delivered with great regularity.

5014. *Ruston and Proctor*.—Four belts on the left side, one of them from the drum-shaft, in the same direction as the engine-belt; four belts on the right side. This machine resembles Clayton's in having its frame well trussed. The truss in this case is of flattened half-round iron, in a  $\Lambda$  shape; the bases of the  $\Lambda$  are placed above the axles of the fore and hind wheels. The strength of this frame has been tested by a weight of 12 tons placed upon it without producing deflection. It resembles Marshall's machine in having the corn-elevator *within* the frame, and in having both the fans placed beneath the frame, the second blast being carried along an air chamber to the second winnowing-sieves, and thence under the drum. The chaff is bagged, and is raised above the chaff-spouts by an elevator similar in construction to Underhill's well-known corn-elevator. The frame of the second sieve-box is moved from the riddle crank-shaft by two connecting-rods and a lever placed at the back, and outside the main frame. The caving-riddle, as usual, is of mahogany; the holes are countersunk from the upper side, making them larger at the top than the bottom.

4980. *Nalder and Nalder*.—Three belts on the left, only one of them from the drum-shaft, and that one draws in the opposite direction to the engine-belt; three belts on the right, two of them from the drum-shaft, but on opposite sides of it. One of these straps passes round three pulleys on the shafts of the drum, hummeller, and upper fan respectively. The shog-board crank-shaft is not driven by a belt from the drum-shaft, but by one from the straw shaker-shaft. Chaff is not bagged, but is delivered on to the ground just behind the hind wheels, a board being used to keep it clear of the corn-sacks. Instead of the usual

Coulson's spring-hangers, the vibrating shoes are suspended on wooden hangers of an extra breadth, the object being to prevent lateral play and obviate the necessity of the parallel guides used in most other machines. The Nalder Patent Adjustable Corn-screen, used in this and in two other machines in this class, differs from most adjustable screens in having the wires fixed. The meshes are made fine at the feed-end, and gradually enlarged to the outlet-end: what passes through the first division of the screen will always be the smallest or third corn. The size of the corn falling through the screen will increase throughout the length of the cylinder. The adjustable part consists simply of a sliding double hopper beneath the screen, which is shifted at pleasure, to direct more or less of the corn that has passed through the intermediate-sized meshes into the spouts for heads and for seconds corn. The wires are of steel, and, being riveted in position, are made smaller than the shifting-wires used in other adjustable screens; a greater number of screening spaces are thus obtained in the same length of screen. The travelling wheels of iron have their fellos lightened by being pierced with oval holes. In the trial no blocks were used under the wheels, but the machine was kept steady by locking the hind wheels by means of a bolt passed through one of the holes in the fellos. The surface of the caving-riddle is grooved across the direction in which the cavings pass.

4992. *Tasker and Sons*.—Three belts on the left, two of them from the drum-shaft; four belts on the right side, three of them, from the drum-shaft, all drawing forwards. Such an arrangement of belts will naturally result in hot bearings, as recorded in the trial. A peculiarity in this machine is the use of two corn-elevators, one on each side of the main frame, and only one set of fans. The first elevator delivers the corn in the usual way into the hummeller; it then passes by a shoot down through the centre of the shog-board into a second winnowing-box, fixed upon the under side of the shog-board; here it receives a forward blast from the same fans that made the first separation of chaff from corn. An objection to this arrangement is, that it sends any unshelled white coats that may have passed through the hummeller in among the straw. After the second winnowing the corn is raised by the second elevator to the rotary-screen, and is thence delivered into sacks. There does not seem to be much advantage in thus substituting a second elevator for a second fan. The shakers are carried at their outer ends on a crank-shaft, and at their inner ends on a rocking-bar. The frame is good and well trussed with A shaped iron. An iron bracket affords an outer bearing to the drum-shaft beyond the driving-rigger. The chaff was delivered into bags.

The dressing by this machine was not well done, as many seeds were blown into the straw; and from column 24 we see that 20 lbs. of good corn were left in the spoutings or capes.

The caving-riddle is grooved longitudinally, with plain holes sunk in the grooves.

4897. *Tuxford and Sons*.—Four belts on the left: only one is taken from the drum-shaft, and is placed opposite to the engine-belt; four belts on the right, three of them from the drum-shaft. The resultant of these pressures would be in the direction of A, Fig. 10, and would counteract the pressure of the sheaf-corn upon the drum. The chaff is not bagged, but delivered on the ground under the machine. A single fan is used, with a divided blast. The caving-riddle is double, each part having eccentric counter-sinking to the perforations. The diameter of the holes is  $\frac{3}{4}$  inch in the upper and  $\frac{1}{2}$  inch in the lower riddle. The holes in the lower riddle proved too small in the

Fig. 10.

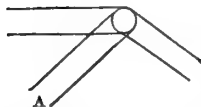

trial, and much chaff passed over with the cavings. The white-coater is conical.



The rotary-screen has a very neat method of adjustment. It is formed of longitudinal steel-bars, with a square section; each wire is cranked at one end, and by a simple arrangement they can all be turned simultaneously, so as to present either their angles or their flat sides to each other, the space between them varying accordingly.

The shaking of the straw was not done satisfactorily.

9252. *Barrows and Stewart*.—Two belts on the left side; one of them, from the drum-shaft, works in the same direction as the driving-belt from the engine. Four belts on the right side, two of them, from the drum-shaft, both pulling the shaft forward. The chaff is not bagged, but a bean-threshing apparatus is provided. There are two crank-shafts to the shakers. The pulley on the shaft driving the caving-riddle is made heavy, to act as a small fly-wheel; and the caving-riddle is grooved, with plain  $\frac{3}{4}$ -inch holes in the grooves. The machine shook much in working, and the drum-shaft bearing on the left side became very hot.

4883. *E. Humphries*.—Four belts on the left side, two of them from the drum-shaft placed opposite to the driving-belt; a pair of bevelled wheels drive the Rainforth screen. Three belts on the right; two of them, from the drum-shaft, both draw forward. In this and the three machines to be next described the corn is delivered on the left side, and not, as is now more usual in finishing machines, at the back. The *cavings* are delivered at the back, and the chaff in front of them under the machine. A small pulley on the drum-shaft, by means of a short crossed belt, drives the large pulley on the shaker crank-shaft. Its shortness causes the twist of the strap to come very close to the small pulley; this is objectionable, as producing much friction and wearing of the strap. A separate white-coater and hummeller are provided. A Rainforth screen was used. The straw was delivered straight and unbroken, but not well threshed, and much corn was left in the chaff. Both defects resulted from too low a speed.

4883. *E. Humphries*.—In all respects similar to the above, except that for the rotary-screen an oscillating shoe was substituted, having an upper riddle of perforated sheet-iron and a lower sieve of wire-net; this attempt to separate the corn without the use of a rotary-screen did not receive a satisfactory trial. The exhibitor had fixed on the drum-shaft of each of his machines a rigger of 8 inches diameter; this gave too slow a motion to all the parts of the machines, and accounts for their total failure in "finishing" the corn. The caving-riddle, patented by this maker, is well known, and is one of the most popular forms among the great variety of riddles exhibited. It has a plain surface, perforated with holes drilled obliquely to that surface. The object of this is that if short straw in descending over the surface should be jerked head foremost into one of these holes, it should not fall through, but be caught and driven back by the sloping side of the hole opposed to it (see Fig. 11).

The price of No. 4883 is lower than that of any other machine in this class, and its performance was better than that of many of those costing more money.

Fig. 11.—Section of part of *E. Humphries' Caving-riddle*.



5097. *Joseph Gilbert*.—Three belts on the left side, two of them from the drum-shaft opposite to the engine-belt; a pair of bevel wheels drive the Penney-screen. Three belts on the right side, two of them from the drum-shaft, both drawing the shaft forwards. In this machine the drum differs from those already described, in being to some extent closed by means of iron-wires ( $\frac{3}{8}$  inch diameter and 1 inch apart from centre to centre), which are wrapped round the drum-frame; the eight steel Goucher-beaters are fastened on woode n

frames in the ordinary way, and project from the periphery of this wire-cylinder. The concave is of the usual construction, with longitudinal flat bars,  $2\frac{1}{2}$  inches from centre to centre, and curved iron-wires,  $\frac{1}{4}$  inch diameter and  $\frac{3}{4}$  inch from centre to centre. The shakers are carried on rocking-links at the delivery ends, and on a crank-shaft at their inner ends. This arrangement does not secure an efficient jerk throughout the length of the shakers. A double caving-riddle is employed, the two parts of which move independently. The upper riddle has large oval holes,  $1\frac{1}{4}$  to  $1\frac{3}{4}$  inch diameter; the lower riddle is one of Humphries' make. The bevel-wheel employed to drive the screen is noisy; the bearing being rather far from the wheel, the shaft springs a little in working. The corn is delivered on the left side, the cavings at the back, and the chaff is delivered on the ground under the hind wheels, a part not easy to get at for removing it. The frame, of oak, is well constructed, but the position of the screen-case is objectionable; it projects over the left-hand fore wheel, and is thus liable to be damaged in travelling. Special means are adopted to prevent any such injury to the corn elevator case. It is attached to the outside of the frame by bolts working in slots, and by means of a long-handled lever it can be raised 9 inches. Thus, when at work, the bottom of the case is only 7 inches, but when travelling it is 16 inches above the ground. This is a low-priced machine, which did its work very fairly.

4985. *P. and H. P. Gibbons.*—Three belts on the left, two of them from the drum-shaft, one being opposite to the engine-belt. Three belts on the right, two of which are from the drum-shaft on opposite sides, and balance each other. Three pairs of bevel-wheels are employed to drive respectively one of Penney's screens, the fans beneath the frame, and a long hummeller placed outside the frame. These bevel-gearings were rather noisy in working, and are not so well adapted as friction-belts for use in a portable machine. The corn is delivered on the right side, the screen being placed over the fore-wheel; chaff is blown out on the left side, the fans being placed near the ground, and *behind* the hind-wheels. We have here a machine in which the elevator, hummeller, screen, and fan-case, are all placed outside the main frame. By this means ample room is obtained for the working parts, so that there can be no fear of clogging up when the grain is in bad condition. We think, however, this advantage is counterbalanced by the inconvenient width of the machine; the parts projecting over the wheels would be liable to injury in travelling. Only four shaker-boxes are used for the straw; two of these are on a crank-shaft at their delivery end, and the other two on a crank-shaft at their inner end, the other ends of each box are carried on rocking links. The feeding of this machine was well done. The feeder stood a little on one side of the mouth of the drum, and did not take the sheaf into his hands, but had it placed on the floor in front; he then spread it a little, and pushed it along the floor to the drum. He thus, with less exertion, fed with more than the usual regularity.

4228. *Holmes and Sons.*—In this and the following machine the winnower that separates the chaff from the corn is placed at the top of the machine instead of under it; the drum, and other heavy working parts, are thus brought much closer to the ground, an arrangement which ensures steadiness in working. There are two belts on the left side; one of them, from the drum-shaft placed opposite to the engine-belt, is bent at a right angle round two friction-pulleys, to convey power to the fans, which, by a cross blast, blow the chaff into bags placed on the right side. There are three belts on the right, and a short belt at the top of the machine. The construction of the machine is similar to that of the non-finishing machine, No. 4229, in Class III (see Fig. 17, p. 436).

The corn and chaff, after falling through the caving riddle, are together raised by an elevator furnished with cups of an extra size. The capes, which in most machines are delivered into a basket placed upon the ground, are here

delivered close to the mouth of the drum, whence the feeder can easily sweep them in to be rethreshed. The drum-beaters are of malleable cast iron, and the concave of wrought-iron wire. The shakers are driven by two crank-shafts.

The bearings of the shafts to the shakers and to the caving riddle are of wood boiled in oil. This sort of bearing is usually very durable, but we do not find it good for threshing-machines used where there is much sharp sand in the soil. The sand scattered in threshing becomes embedded in the wood, which then acts like a file, rapidly eating away the shaft revolving in it.

It will be noticed that this machine made the shortest run in the trial. The ton of sheaf-corn was switched through it in less than twelve minutes. If more time had been taken, and the sheaves had been properly opened before throwing them into the drum, a much better result might have been attained. One result of this too great haste was that the straw was more broken, and more cavings made, than by any other machine. Nalder's screen was used, and the corn was delivered at the back of the machine.

4203. *Riches and Watts*.—In the arrangement of its parts this machine is similar to the preceding. It has one belt on the left side, passing from the drum-shaft opposite to the engine-belt, and carried at a right angle round two friction-pulleys; a short belt at the top, and four belts on the right. A *step* caving riddle with plain holes. The straw shakers are carried on two crank-shafts. The chief peculiarity in this machine was the substitution of a Child's Patent Aspirator for the ordinary rotary screen. An exhaust fan placed on the left side of the machine draws to itself a strong cross blast of air. The grain, on leaving the hummeller, falls through this blast, which should effect a separation of the grain according to its specific gravity and bulk. The air-current may be increased or diminished in power at the will of the operator. The openings through which the air is drawn are on the right side of the machine, and a spring trap-door is required where the corn passes out, to prevent air being drawn up the corn-spout instead of across the machine. This trap-door is opened by the weight of the corn falling upon it. In the preliminary trial with 20 sheaves the weight of corn extracted was not sufficient to open the trap-door. The attendant, not content with opening this door by hand, *wedged* it open, so that, throughout the trial in chief, the air was drawn up the corn-spout, and no separation of the corn effected. We had, therefore, no opportunity of judging how far the aspirator, that, as a separate machine, is much used by millers and others, is suited to effect the finishing operation in a threshing-machine.

4658. *Ransomes, Sims, and Head*.—This machine differs more in construction from the common type than any of those yet described. The chief difference in its external appearance is due to the absence of box-shakers; which allows the fore-part of the frame to be left quite open at the sides, thus giving an apparent lightness to the whole machine. The frame is of pitch-pine and ash, and large iron washers are introduced under the head of each of the bolts that hold the frame together. The motive-power is distributed by two belts on the left; one of them from the drum-shaft is opposite to the engine-belt. There are five belts on the right, three of them are on the drum-shaft, two drawing back, and one forward. A spur-wheel and pinion drive the corn-elevator.

The illustration (Fig. 12, p. 430) shows the right-hand side of the machine. The drum-shaft is seen in the centre; and of the three belts that radiate from it, the upper and hinder one drives the hummeller, the lower one drives the screw-shaped fans that give a second cross-blast, and the front belt drives the crank-shaft which moves the caving riddle. The rigger on this crank-shaft is 20 inches in diameter, while the rigger on the drum-shaft is only 4 inches, the cross of the belt is consequently very near the small rigger. This belt ran with much chafing, and produced an unpleasant flapping during the trial.

The small belt from the fan-shaft drives a pinion, which works into a spur-wheel on the frame of the rotary screen. In the fore-carriage, we may notice

Fig. 12.—View of the right-hand side of Messrs. Ransomes, Sims, and Head's Threshing Machine. No. 4658.

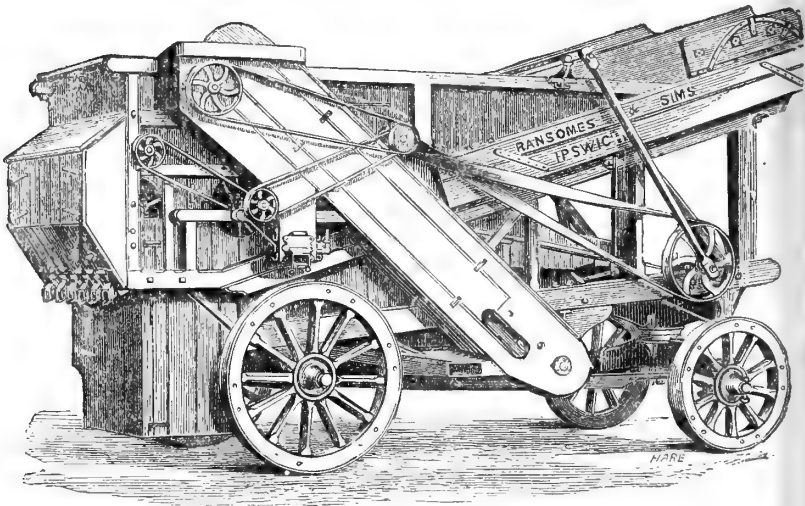

the ball-and-socket joint in the locking gear, which enables the wheels to adapt themselves to the inequalities of roads when travelling, and causes the machine to stand steady on uneven ground.

Several novelties have recently been introduced into this machine, after having been patented by their inventor, Mr. Brinsmead. Of these we take first the hexagonal drum, of which a section (I.), and a plan of part of its periphery (II.) are shown in Fig. 13.

Fig. 13.—Section (I.) and Plan of part of Periphery (II.) of Brinsmead's Patent Hexagonal Drum.

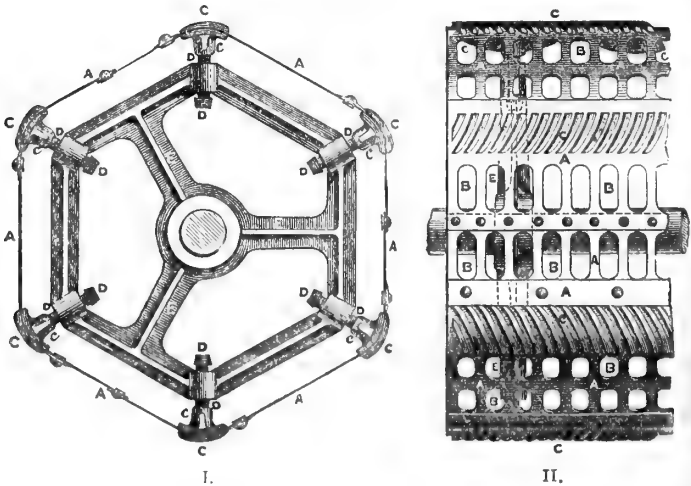

(A A) is a sheet of charcoal plate-iron enveloping the drum, and lightened by the perforations (B B). At the angles of the hexagon the ribs of the beater-bars (C C) project through the iron plate. The beater-bars are kept in their places by the set-screws (D D), which are tapped into the cast-iron heads (E E), keyed upon the drum-spindle. The screws press against the back of the beater-bars, and these, pressing against the internal surface of the iron sheet, keep it stretched out and rigid. The beaters are made in segments of 6 inches each, and all that is needed for replacing any one of them is to slacken the single set-screw that holds it in position. The beaters are of cast iron, the ribs or parts projecting through the hexagon being "chilled." The entire drum being of iron and symmetrical, the balance, when once obtained, is not liable to be disturbed by climate or temperature. The concave (Fig. 14) used in combination with the above drum is composed of malleable-iron gratings (A A), and wrought-iron bars (B B), alternately bolted together in such a manner that they may be readily taken to pieces, and the wrought-iron bars turned round to present the other edges to the action of the drum when the first becomes worn. The

Fig. 14.—Section (I.) and Plan (II.) of part of the Concave used with Brinsmead's Patent Hexagonal Drum.

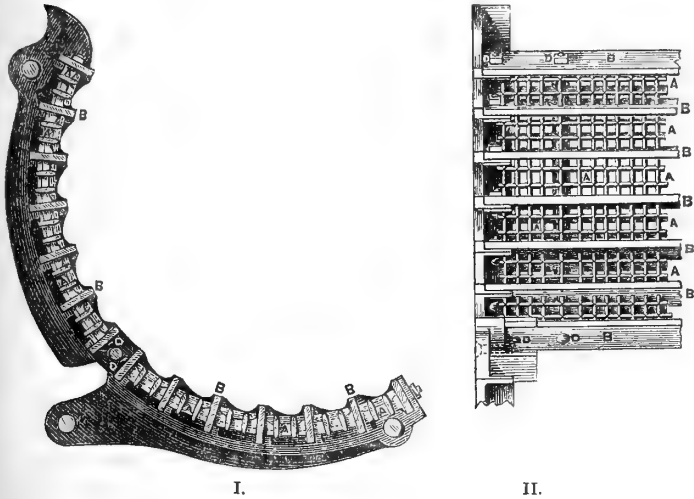

gratings have square apertures of such size as to prevent the passage of unthreshed broken ears, but still affording ample space for the escape of the grain. Eight curved bolts (D D) passing through the gratings and the bars hold the parts of the concave together. The drum being closed instead of open, will have more of a rubbing, and less of a beating, action upon the corn than the usual form of drum. It thoroughly extracted the corn in the trial, but must, we think, absorb more power than the open drum; this point, however, we were not able to test by direct experiment.

The passage of the grain and straw from the drum and the arrangement of the other parts of the machine are shown in Fig. 16 (p. 433), a longitudinal section. The straw passing from the drum is thrown upon the rotary straw shaker, formed of fifteen revolving triangular rollers (B) having fixed upon each of their edges a series of curved iron teeth, so arranged that the teeth of each roller shall clean themselves by passing between the teeth of the rollers on each side of it. These teeth toss the long straw upwards and forwards, while the cavings,

chaff, and corn falling between them are swept back by the same action along the incline (*b*) to the shog-board (*C'*), which also receives the corn and chaff that fall through the concave (*a*), and passes them on to the riddle (*C*). The holes in this riddle are conical, with the largest diameter below to avoid clogging; their upper diameter being  $\frac{1}{2}$ -inch for wheat and  $\frac{5}{8}$ -inch for barley. The surface of the riddle is grooved in the direction in which the cavings pass.

Fig. 15.—*Transverse section of a part of the Caving-riddle.*

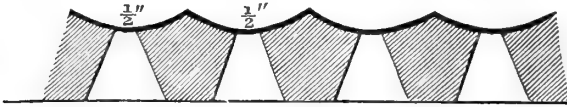

The cavings are delivered on the ground behind the fore-wheels; the chaff and grain falling upon the collecting-boards (*D D*) are passed over a fine metal screen which removes all weed seeds, and are next conveyed to the sieve, which occupies the lower part of the same frame (*E*); here a blast from the fan (*F*) separates the chaff and throws it upon the inclined perforated plate (*G*), through which the air escapes while the chaff slides down into a sheet-iron trough, in the bottom of which is a revolving screw (*H*). The screw conveys the chaff to the side of the machine, where it is caught up by a centrifugal lift and thrown into the receiving-box to which the chaff-bags are attached. The corn falling through the sieve (*E*) is conveyed by the channel (*E'*) to the receptacle below the corn-elevator cups (*J J*); these carry it up and deliver it to the chob-cleaner or hummeller (*K*), a conical cylinder, the interior of which is formed of rough surfaces. Inside this cylinder a small drum revolves, on the periphery of which are placed four or six beaters fitted with knives. By passing between the rough surface of the cylinder and the sharp beaters the grain is separated from the chobs or awns, which are subsequently removed by a cross blast which meets the corn as it falls from the hummeller into the oscillating shoe (*L*). This shoe moves with the caving-riddle, to which it is connected by iron rods. The cross blast is obtained from the screw-shaped fan (*M*), which sends the current of air in the direction of its shaft. This form of fan has a considerable advantage over the usual one (where a cross blast is required), since it can be driven by a simple straight belt. From the shoe (*L*) the grain passes to the rotary screen (*N*), which consists of two separate cylinders of wire revolving on the same shaft, and so constructed that the spaces between each cylinder may be exactly adjusted by means of an eccentric on the shaft. The screen is self-cleaning and does not require brushes or washers behind the wires. From the screen the grain is delivered into sacks placed at the back of the machine. Two other points deserve notice. The riddle (*C*) and the shog-board (*C'*) are suspended, not upon the usual wooden spring hangers, but upon hangers made of woven galvanized-iron wire. The action of the rotary shakers is assisted by the vibrating fork (*O*), which consists of a series of long bent iron teeth set in a rocking-bar placed across the frame and moved by the wooden connecting-rod (*P*) from the crank-shaft (*Q*), which oscillates the caving-riddle. By a recent improvement this vibrating-fork has been fitted with an adjustment by which it can be set nearer to or further from the shakers. Whenever a thickened lock of straw passes from the drum it is caught by these teeth, which give it one backward and one forward shake before letting it go well spread out, to be carried in a series of light hops over the shaker rollers. If there is greater economy of power, as we think there must be, in the rotary as compared with the ordinary box shakers, it appears to be lost in some other part of the machine, for an inspection of column 22 (Tables I.—III.) shows that it absorbed rather more than the average taken by other machines.

Fig. 16.—Longitudinal section of Messrs. Ransomes, Sims, and Head's Threshing-machine, No. 4658.

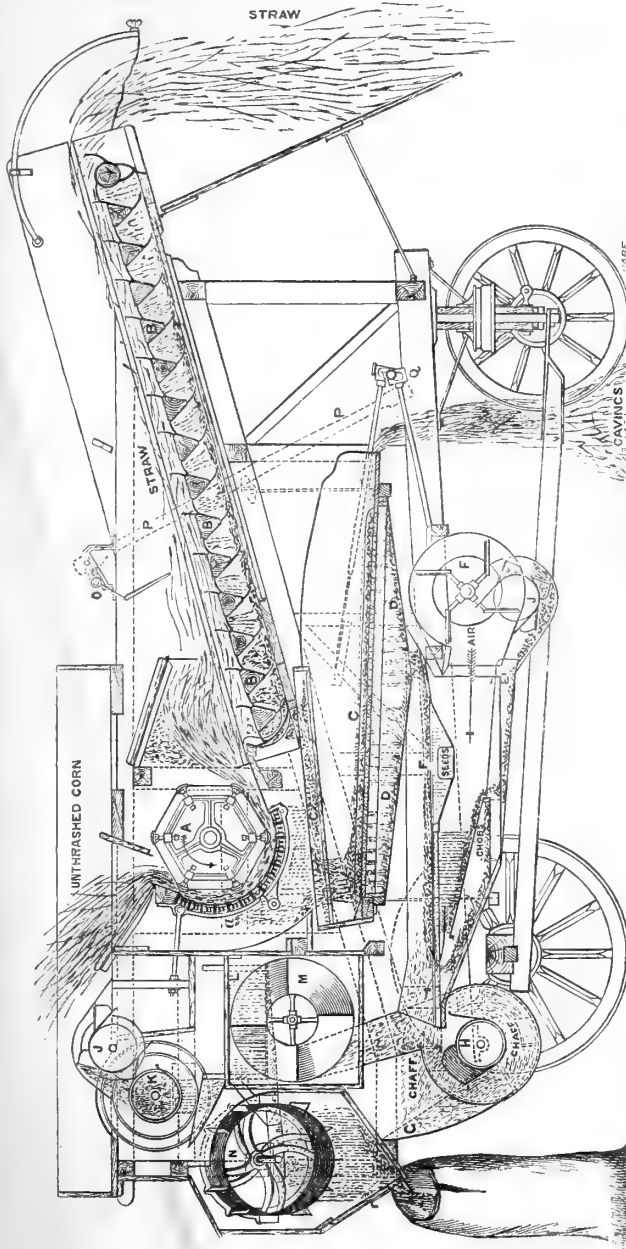

- A. Drum.
- a. Concave.
- B. Straw shakers.
- b. Inclined board.
- C. Shog-board.
- C. Caving-riddle.
- D. Collecting-boards.
- E. Dresser.
- F. Corn-shoot.
- F. Fan.
- G. Perforated plate.
- H. Revolving screw.
- J. Elevator cups.
- K. Hummeller.
- L. Oscillating sieve.
- M. Second fan.
- N. Rotary screen.
- O. Vibrating fork.
- P. Connecting-rod.
- Q. Crank-shaft.

CLASS III.—*Threshing Machines (not Finishing).*

Before describing the first run in this class, it may be well to refer briefly to one or two of the trials previously made by the Society. One of the earliest notices of the general use of portable threshing machines will be found in Mr. Pusey's Report in 1851, which he commences with the remark, as true now as then, that it is "the most complicated agricultural machine in general use." Its very complication has made its progress slow in reaching its present state of finish. At the important trials at Chester in 1858 the Judges report (speaking of fixed as well as portable machines), "Only 4 out of 55 trials of steam-power machines received our number denoting perfection in clean threshing." "Only 11 threshed without injury to the grain, only 5 dressed perfectly, 3 shook the straw satisfactorily—the same 3 alone produced the cavings free from corn; and 13 produced chaff without corn."

In the full and valuable report of the most recent trials at Bury St. Edmund's in 1867, the Judges suggest the discontinuance of prizes for horse-power threshing machines, as their use at that time was considered "indicative of a backward condition of agriculture." At the same time they express a strong preference (based on the actual results of the trial) for the non-finishing machines, over those "that were supposed to dress up the sample ready for delivery."

This year we have the satisfaction of reporting a great improvement in the performance of the finishing machines, and were led to anticipate this improvement by the fact that for the last three or four years the demand for machines to be used in England has been almost confined to finishing machines; some of the largest manufacturers have stated that they sell fifty finishing to one single-blast machine; while those who do most trade in the simpler machines say they make twice as many of those in Class II. It was a striking evidence of the comparatively small demand for single-blast machines that some of those brought for trial in Class III. had their frames made to receive a screen and second fan; one exhibitor, replying to our remark on the disadvantage of having the frame unnecessarily large, said that he should fit in the finishing appliances immediately on his return home, as he had no demand for non-finishers.

The pace of agriculture can no longer be deemed proverbially slow when we find a whole class of complicated machinery that five years ago was considered to do all that it was desirable one implement should attempt, now almost superseded by equally efficient though more complex machines. Seven years will probably elapse before threshing machines again come on for trial, and it is not improbable that before that time the non-finishing



machines will be as antiquated as were the horse-power machines in 1867. The greater part of the threshing on our farms is now done by hired machines, and it is necessary for those who work by contract to have machines capable of suiting all customers. The truth that a somewhat wasteful application of steam power is much cheaper than the most economical manual labour has long been known theoretically, and is daily becoming more generally recognized in practice.

The results of the first trial with 10 cwts. of sheaf-corn in this class are given in Table IV. The columns in this Table will be found to differ little from those in Tables I., II., and III., except that the column for the description of finishing screen is of course omitted; none being used, only one column is needed for the corn delivered into sacks. The points of merit are, with the omission of "Perfection of Finish," the same as those in the former trials. On comparing column 12 with the corresponding column 13 in Table I., we may notice that the "non-finishing" machines take about 2-horse power less to drive them when empty than the finishing machines. In Table IV. they also take considerably less power when at work. But on the other hand, when we compare Table V. with Table II., we find more horse-power required for the second run of the non-finishing than for the second run of the finishing machines. The apparent anomaly is due to atmospheric influences. Heavy rain was falling during the second trial in Class III., and though the sheaves had been safely housed they were damp and required much more power to thresh them. The increase of power employed in the second trial, as compared with the first trial in Class III. (see column 21), varies from 14 per cent. in the case of Marshall, Sons, and Co., up to more than 58 per cent. in Ransomes, Sims, and Head's machine.

Had the rules for judging been as stringent as they were at the Bury trial, every machine would have been disqualified in the second trial for exceeding 8-horse power, and only four would have escaped disqualification in the first trial. In instructions to Judges, the adage, "Loose will wear, tight will tear," is often exemplified.

It will be unnecessary to describe the construction of most of the machines in this class, since they differ little from the machines by the same makers described in Class II., except in the omission of the finishing screen, and in the omission also, in some cases, of the second fan. Column 9 (Table IV.) shows which are the single-blast machines. In most of the machines in this class the *avings* are delivered at the back and the corn at the side.

4229. *Holmes and Sons*.—In the run of this machine, the upper part of the concave, being adjusted after the trial with ten sheaves, was not made secure,

and consequently was forced wide open in the trial in chief; this was unfortunate, as the results of the subsequent trial show that this machine is capable of doing excellent work. Fig. 17 shows the general arrangement of parts. The drum-shaft seen in the centre of the cut is placed lower than in most machines; the cavings are delivered at the back; the corn and chaff fall through the caving-riddle upon a fine screen that removes small weed seeds, and are then together raised on the left side by an elevator, with very large cups, to the winnowing apparatus upon the top of the frame. The chaff, it will be noticed, falls at once into bags, and does not need any separate bagging apparatus, as in machines that have the winnowing-box under instead of above the frame. The chobs are similarly delivered to the drum, and do not need to be raised in a basket, as is commonly done, by hand. The corn is delivered into sacks on the left side.

Fig. 17.—View of left side of Holmes and Sons' Threshing Machine, No. 4229.

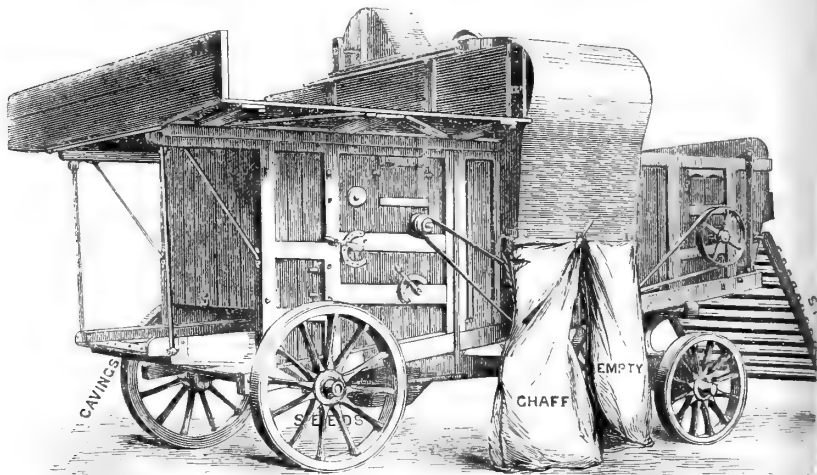

2953. *Barrows and Stewart*.—The frame is made as for a finishing-machine, but with the case intended for the rotary screen empty. Three belts are driven from the right-hand end of the drum-shaft, and the outside strap is placed so far from the bearing that there is a tendency to bend the shaft and so work unevenly on the bearing. Even in the short time of trial this bearing heated. Only four shaker-boxes are used. The delivery ends of these are fixed alternately on two cross-bars; these bars are carried on wooden spring hangers. The inner ends of the shakers are driven in the usual way by a crank-shaft. This method does not give sufficient jerking to the straw at the delivery end, consequently the points in column 29 are low. In the trial the wheels were not properly held in position, consequently the machine worked very unsteadily.

4885. *Edward Humphries*.—Drum-beaters used with a plain surface. Shaker-cranks work in bearings of wood, boiled in oil. The belt on the right-hand end of the drum-shaft, driving the white coater, is placed 11 inches (measured to the middle of the strap) from the bearing, which consequently heated in the trial. A double-blast machine.

4661. *Ransomes, Sims, and Head*.—A single blast-machine, with drum 5 feet long; in other respects similar to the one described in Class II. Delivers the chaff into bags. Many loose corns were thrown out by the drum; so a hood was required to catch these. The extra length of the drum enabled it to thresh out the corn in less time than the other machines that did the work effectively.

4986. *P. and H. P. Gibbons*.—A double-blast machine, similar to their finishing-machine.

4006. *Ashby, Jeffery, and Luke*.—A double-blast machine. One belt on the right, three on the left side, and one belt within the frame of the machine; this belt is difficult to take off and put on. Five box-shakers, two of them carried on short upright wooden rockers at the delivery end and on a crank at the other end; the other three shakers are carried similarly, but *vice versa*. These shakers did not remove the straw as fast as the drum delivered it to them. The machine choked, and feeding had to be suspended.

2928. *Reading Iron Works*.—This was the only machine in which Underhill's patent corn-elevator was employed instead of the usual cup-elevators. In this form of elevator the grain is thrown up by a series of smart blows from some spade-shaped beaters set on an ordinary fan-spindle, and revolving at a high speed. When the grain is of average quality this one operation raises the corn and knocks the wheat out of the white coats or the awns off barley; it thus greatly simplifies the machine, as the hummeller, elevator-cups, and several belts and pulleys, can be dispensed with: but it has the serious drawback (fatal in a machine to be hired for work on all sorts of land) that it breaks the corn when dry and brittle. This machine was provided with an index for the set of the concave. The five box-shakers are carried on two crankshafts. The bearings are self-lubricating. Worked steadily, but scattered some corn on the ground beneath it.

5026. *Marshall, Sons, and Co*.—A double-blast machine, made so that the finishing-apparatus and screen can be added at any time to make it in all respects similar to the machines tried in Class II. The cavings are delivered under the frame, and the corn, as in Class II., at the back.

4981. *Nalder and Nalder*.—A double-blast machine, delivering corn at the back, and cavings under the frame.

5098. *Joseph Gilbert*.—Like the machine in Class II., but without the second riddle-case and Penney-screen.

4993. *Tasker and Sons*.—A single-blast machine, with chaff-bagging apparatus.

4994. *Clayton and Shuttleworth*.—A single-blast machine, of excellent construction and workmanship. Chaff-bagging apparatus provided. The corn is delivered on the left side into sacks placed 3 feet from the ground—a convenient arrangement, enabling the attendant to take the sack on his shoulders without further assistance. All the bearings are brassed. The index to the concave is very distinct.

The patent trussed frame, the steel drum-spindle, the patent rolled-steel beater-plates, and Good's patent single-crank shakers, are used in this as in the finishing-machine. In adjusting this machine the neatness and convenience of the exhibitors' adjusting-blocks were well displayed.

4662. *Ransomes, Sims, and Head*.—In this machine, and in the 4663, to be described shortly, the construction is arranged to suit the special requirements of the east and south of Europe. Most of our chief manufacturers of threshing-machines make twice as many to go abroad as they make for home use. The exhibition of these two machines added to the general interest of the trials; but it will be seen that the Judges did not consider their work sufficiently suited to the wants of English farmers to qualify them for competing in the second trial. Number 4662 is specially adapted for threshing large quantities of grain in a very short space of time, and is much used in the

corn-growing districts of Hungary, Wallachia, South Russia, and Turkey. All its parts are extremely strong, and the bearings are provided with large oil-cups, made in two divisions for oil or tallow, so that it can work for a long time without requiring attention. The drum-beaters are made of wrought iron in the form of a screw, and can be turned round to bring a fresh part to act on the grain when one side is worn. The concave is composed of flat bars of wrought iron fixed upon wooden beds. The rotary shakers are double instead of being single. After the straw leaves the first set of shakers it falls over a space of about 24 inches on to the second shakers. The object of this is to get a greater surface and more rapid incline, in order that the grain may be perfectly extracted from the great bulk of straw that has to be shaken. The riddles have a very large surface. There is no division of seeds from the chaff. The cavings are delivered under the straw, and the chaff just behind the cavings. In practice the boards dividing these products are commonly removed, so that all are mixed either for fodder or for burning. The chob-cleaner in both these foreign machines is similar to that described in Class II. The straps are all of a uniform width, so that they may be easily repaired. It will be noticed that the 10 cwts. of sheaf corn were disposed of in the extraordinary short space of little more than four and a half minutes. At the end of the run the bearings were found quite cool; but the same remark would not be true of the feeder, who, with his assistants, had been working like a "steam-engine in trousers." We were not surprised to learn that in some places two men are employed to feed the drum.

5015. *Ruston, Proctor, and Co.*—A strongly made double-blast machine; it does not bag the chaff. The corn is delivered at the back of the machine. The cavings are delivered behind the straw, then the chaff, chobs, and seeds respectively, one behind the other. The sides of the frame are partially open, to give access to the bearings. The chobs or spoutings contained many broken pieces of ears; these had probably escaped through the concave, imperfectly threshed.

4663. *Ransomes, Sims, and Head.*—This machine is specially adapted for use in hot countries: in general construction it is similar to No. 4662, but with a shorter drum, a single set of rotary shakers, and the important addition of an apparatus for chopping and bruising the straw, so as to render it fit food for cattle.

In Spain, Italy, Turkey, and South America where hay does not grow, the animals are fed almost exclusively upon straw, which contains a larger amount of silica and saccharine matter than English straw; and as this straw is very hard, it requires to be cut up in short lengths, and bruised and softened before it can be masticated.

Until this machine was invented, this operation was performed by mares galloping over the grain, laid out upon a large round threshing floor. The combined operation of threshing the corn and bruising the straw is performed much more rapidly and economically by steam than by horses, and the cattle fed on the straw thrive better on account of the absence of dirt, dung, and other foreign substances which accumulated under the feet of the mares. The apparatus for chopping and bruising the straw is shown in section at R and S in Fig. 18 on the next page, from a block kindly lent by the editor of the 'Chamber of Agriculture Journal.' Two cylinders revolving at a great speed are placed one above the other on cast-iron standards fixed to the front of the frame of the machine, and connected with the straw-shaker by means of a large hopper into which the straight straw falls. The upper cylinder (R), which makes about 1117 revolutions per minute, is fitted with a number of sharp knives, which cut the straw into lengths of about 1 inch, whilst the lower one (S), making 1070 revolutions, is furnished with rectangular blunt projections, which split and soften the short pieces of straw. Each roller works in conjunction with a

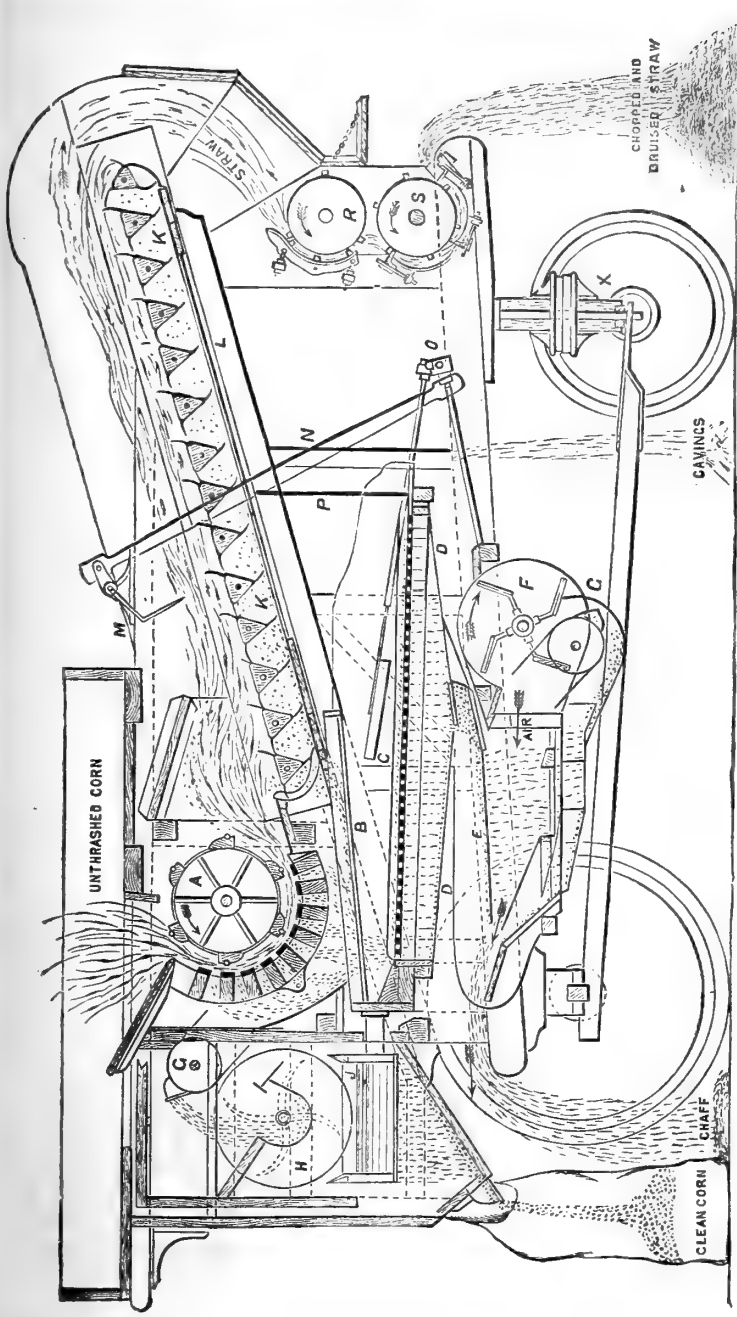

- A. Drum.
- B. Shog-board.
- C. Caving-riddle.
- D. D. Collecting-boards.
- E. Dresser.
- F. Fan.
- G. G. Elevator-pulleys.
- H. Hummeller.
- J. Corn-screen.
- K. Straw shaker.
- M. Vibrating fork.
- N. Connecting-rod.
- O. Crank-shaft.
- R, S. Straw-bruising cylinders.

concave fixed to the cast-iron standards, the upper one being furnished with sharp knives and the lower one with blunt projections. A small flywheel is fixed on the right extremity of the shaft of each of these drums. Each drum is set close, so that the projections on the drum surface work between those on the concave, the general effect reminding one of a huge sausage-machine. The straw falling from the shakers is seized and whirled through these drums with great velocity, and is sent flying out in a cataract that falls to the ground 6 feet away from the open drum-case, while the dust and smaller fragments float off in the air like spray from a waterfall, but without possessing the refreshing property that liquid spray might have for those whose bronchial tubes have already had a sufficiency of similar dust. It will be seen from column 21, Table IV., that the power required for this double operation was more than double that required for the threshing alone.

Looking at the results of this first trial, we find the firm of Clayton and Shuttleworth taking the same position as in the first heat of the previous race. With a possible score of 430, they take the first place with 411 points to their credit. Ransomes, Sims, and Head, with their No. 4661 machine, stand a very good second with 404 points. Next, but at a wider interval, comes No. 4981, Nalder and Nalder, with 387 points.

Seven machines having been selected for a second run, were tried with 1 ton each of sheaf corn on Thursday. This fourth day of the trial will not quickly be forgotten; a steady and continuous rain made the threshing a tough job for the machines and greatly thinned the attendance of spectators. The threshing, though clean, was done at a great expense of power, and we may learn from columns 34 and 35 in Table V. that threshing in wet weather cannot be done without injury to the grain and the straw. In order to ascertain how much of the corn left in the straw and caving was the result of inefficient threshing and how much was due to inefficient shaking, three men with forks were employed to re-shake the straw by hand before it was taken away to be re-threshed; the quantity of corn thus obtained is recorded in column 23. This test, however, was hardly satisfactory, and was not repeated in other trials, as the labourers seemed to think it "much ado about nothing," and it was difficult to secure thorough shaking towards the end of the trial. The corn obtained by the re-threshing in this trial was subsequently dressed by hand power, and the best and seconds corn are entered in columns 24 and 25. It must not, however, be supposed that the "best" of this corn was all plump and good grain, very little of it in fact was worthy of being classed as the "head corn," so that we may say, while most of the machines in this trial left less than one half per cent. of the grain unextracted, that half per cent. was chiefly composed of lean and shrivelled grains. In the lower part of columns 11, 12, and 13, it will be observed that we have not repeated the results obtained in running the machines empty, but have filled up the space with descriptions of the shakers and caving riddles. The

form of shakers used by each maker was the same in Class II, as in Class III. To ascertain which form of shaker did the best work, we may therefore take the average results which the three or four trials with wheat afforded in the two classes.

Exhibitor's Name.	No. of Article.	Description.	Average of Trials.	Points of Merit for Clean Shaking.
Clayton & Shuttleworth	4943 and 4944	5 boxes and 1 central crank .. .. .	4	38 $\frac{1}{4}$
Ransomes, Sims, & Head	4658 ,, 4661	Revolving bars .. ..	4	38
Marshall, Sons, & Co. ..	5025 ,, 5026	5 boxes, 2 cranks .. ..	4	37 $\frac{3}{4}$
Nalder & Nalder .. ..	4980 ,, 4981	5 ,, 2 ,, .. ..	3	34 $\frac{3}{4}$
Holmes & Sons .. ..	4228 ,, 4229	5 ,, 2 ,, .. ..	3	34
Tasker & Sons .. ..	4992 ,, 4993	5 boxes, 1 crank, and 1 rocking-shaft ..	4	33 $\frac{1}{4}$
P. & H. P. Gibbons ..	4985 ,, 4986	4 boxes, 2 cranks, and 4 rocking-links ..	3	30 $\frac{3}{4}$

The order of merit is evidently not independent of the methods of construction adopted, and may probably be taken as really indicating their relative advantages.

The single central crank will, we believe, be less costly to maintain than the double cranks, but may probably require more power to work it than is needed by the revolving bars.

Exhibitor's Name.	No. of Article.	Description.	Average of Trials.	Points of Merit. Chaff free from Cavings.
Ransomes, Sims, & Head	4958 and 4661	Longitudinal grooves and conical holes	4	19
Nalder & Nalder .. ..	4980 ,, 4981	Transverse grooves and cylindrical holes	3	18 $\frac{1}{3}$
Clayton & Shuttleworth	4943 ,, 4944	Humphries' Patent, Plain surface in 4 steps oblique cylindrical holes .. ..	4	17 $\frac{1}{2}$
P. & H. P. Gibbons ..	4985 ,, 4986	Transverse grooves, cylindrical holes ..	3	16 $\frac{2}{3}$
Marshall, Sons, and Co.	5025 ,, 5026	Plain surface in 4 steps, cylindr. holes	4	16 $\frac{1}{2}$
Holmes & Sons .. ..	4228 ,, 4229	Plain Surface in 4 steps, conical holes	3	15 $\frac{2}{3}$
Tasker & Sons .. ..	4992 ,, 4993	Longitudinal grooves, cylindrical holes ..	3	14

The construction of caving riddles seems to be a point in which each maker follows his own fancy; hardly two are alike. We fear we can do little to remove the uncertainty that evidently prevails on the question of the best form of riddle. It is easy to be "wise after the event," but in future trials it will be well to make an extra column of merit. No record was made of the freedom of cavings from chaff and grain: without this the entry of chaff free from cavings in column 32, is a one-sided indication of the merits of a riddle for separating cavings from grain and chaff. We have given the averages, for what they are worth, in the preceding page.

Turning now from these special points to the general results of this second run, we find all the competitors well up in the race, with Ransomes, Holmes, and Clayton in the 1st, 2nd and 3rd places. Combining the results of the 1st and 2nd runs, the result stands thus:

No. of Article.	Exhibitor's Name.	Total Points in Two Trials.	Average Foot-lbs. of Work done for 1 lb. Sheaf Corn in the Two Trials.	Awards.
4944	Clayton & Shuttleworth	807	2407	First Prize, 40 <i>l</i> .
4661	Ransomes, Sims, & Head	803	2701	Second Prize, 20 <i>l</i> .
4993	Tasker & Sons .. ..	770	2305	Highly Commended.
5026	Marshall, Sons, & Co. ..	767	3077	Ditto ditto.
4981	Nalder & Nalder .. ..	757	2793	
4986	P. & H. P. Gibbons ..	745	2093	Commended.
4229	Holmes & Sons .. ..	734	2240	Ditto.

The difference in the quantities of corn left in the straw by each machine in these trials is small; but, when we calculate the pecuniary value of the corn that would be thus lost in a year, it is clear that the best machine will generally be the cheapest. In the first trial the worst performance left 5 lbs. more grain in the straw than was left by the best. A threshing-machine would not be purchased by a farmer to thresh a smaller quantity than 800 quarters per annum; one used for hire-work would probably thresh ten times as much in the course of the year. A loss of 5 lbs. of grain from each 6 bushels threshed would, in the first instance, amount to about 5300 lbs., or 10 quarters, worth 20*l*.: while, in the case of a machine in constant work, the value of the grain might amount to 200*l*.

It has been well said that these expensive and complicated machines have, by their *economy*, superseded the sixpenny flail. This is not, however, an economy of force, for, measured by the



foot-lbs. of force expended on each pound of sheaf-corn, the flail is by far the more economical. It might take an able-bodied labourer about seven days to thresh 4 quarters of wheat by flail and prepare it for market. Taking our estimate of a man's power from Mr. Morton's excellent 'Hand-Book of Farm-Labour,' at 200,000 foot-lbs. per day of nine hours, we find the whole force expended to be  $7 \times 200,000 = 1,400,000$  foot-lbs., or only about one-tenth part of the power required to do the same work by machine. The cost of work, however, is not determined by its quantity alone, any more than the value of a coin depends upon its mere weight. Looking at their respective costliness we may call hand-power gold, horse-power silver, and steam-power copper. He who uses hand-power, for work that can be done by steam, is penny-wise and pound-foolish.

In spite of the enormous increase in the power required, steam-threshing costs less than half as much as flail-work; but we may yet well ask how is it that so much more power is required? The sharp blow of the flail is, no doubt, better fitted to extract the grain than is the rubbing action of the drum. With the flail no power was wasted in breaking up the straw; rubbing grain out of the ear by hand has been practised in all ages; to extract it *by rubbing the whole sheaf* is probably a practice confined to modern times. The use of reaping-machines enables us to cut the straw much closer to the ground than formerly; and the bottom of the straw is its stiffest part, and requires much power to drive it through the machine. With a drum of 4 feet 6 inches or 5 feet long, one-third of its length is employed in extracting the grain from the ears, the other two-thirds are chiefly employed in the profitless, and often mischievous, work of breaking the straw. The application of steam to other departments of industry has, in numberless instances, required important modifications of practice before full advantage could be obtained from the new motive-power; and we may well consider whether by any similar modification in our farm-practice it may be possible to get our threshing done with less power, and consequently at less expense.

To attempt to discuss the point here would lead to an unsuitable digression, but we may note it in passing as worth consideration.

In addition to the money prizes, two silver medals were awarded for improvements connected with threshing machines, one of them to Messrs. Ransomes, Sims, and Head for their Patent Drum, already described as a part of their No. 4661 machine in Class II., the other to Messrs. Clayton and Shuttleworth, for their "Wilders'" patent self-feeding apparatus fitted to their double-blast threshing-machine, No. 4951. In order to secure a thorough trial of the apparatus, this machine was

selected by the Stewards to thresh out all the straw during the trials of the straw-elevators in Class IV. Fig. 19, on the opposite page, shows the position of the self-feeder. It consists of the five shaking-boxes A A, worked by a crank underneath, and similar to the ordinary straw-shakers over which the apparatus is fixed. The surface of these boxes is furnished with wooden ratchet-teeth, which convey the untied sheaves towards the drum, loosening them more and more as they progress towards the hood, B, which covers the drum, and prevents the scattering of corn and dust. Across the head of the hood the vibrating adjustable rake, C, is placed. This rake regulates the feed most effectually. During the trial many whole sheaves, with their bands still tied, were placed, as an extreme test, upon the self-feeder; these were almost always retained by the rake till it had shaken the band loose, it then delivered the corn more than half-spread to the drum. When the sheaf-bands had been properly cut, an ordinary labourer was able to feed the machine with as much regularity as the most skilful feeder on the old plan.

The short iron rod, D, connects a crank on a cross-bar or rake-head with the crank-shaft which carries the shaker-boxes, and is itself driven by a belt on the further side of the machine from the crank-shaft which drives the lower straw-shakers. This belt is carried on a fast and loose pulley. The handles, E E, placed within easy reach of either side of the feeder, enable the attendant to shift this belt, and instantly stop the feeding apparatus. The five shaker-boxes are carried upon rocking links at their upper and outer extremities. The crank-shaft, which gives a throw of 5 inches to the ends next the drum, is not shown, but its position is indicated at F.

The patentee of this valuable invention is Mr. Wilders, a tenant-farmer of Croxton Kynil, Grantham, who may be congratulated on having practically solved a problem that has engaged the attention of inventors ever since the introduction of machine-threshing.

Accidents have so frequently occurred under the direct hand-feeding system, that there are probably few machines that have not done some injury to their attendants. A drum revolving 1000 times a minute must inevitably destroy the limb that may be caught by it. Other contrivances for lessening or preventing this risk have failed to secure the proper feeding of the machine, and have in some cases been both cumbersome and costly. In this contrivance the risk to human life and limb is effectually removed, the machine is more regularly fed, and consequently the threshing and finishing will be better than after hand-feeding. While, at a very trifling increase of steam-power, the work of one man is entirely saved, as the sheaf is at once placed upon the

self-acting feeder by the band-cutter. The hood prevents waste, as not a single grain can fly out from the drum. The price of

Fig. 19.—Illustrating Wilders' Patent Self-feeding Apparatus fitted to a threshing-machine.

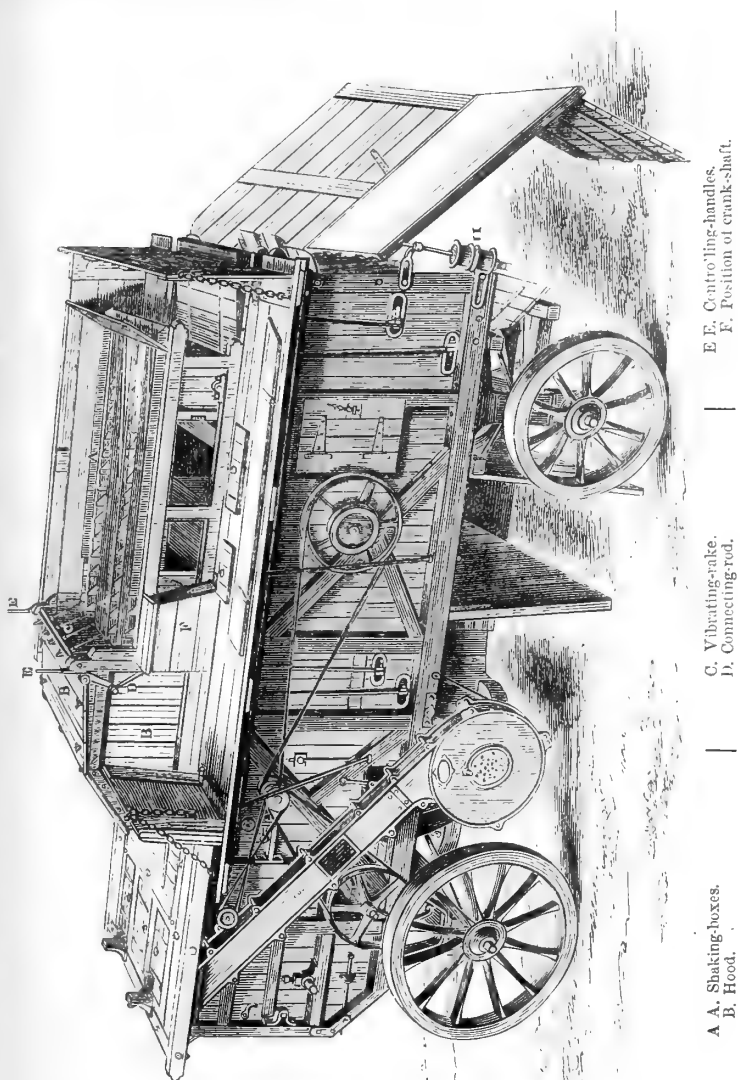

- A. A. Shaking-boxes.
- B. Hood.
- C. Vibrating-rake.
- D. Connecting-rod.
- E. E. Controlling-handles.
- F. F. Position of crank-shaft.

the apparatus is 15*l.*, including royalty; and it can, at a trifling cost, be applied to any form of threshing-machine.

**CLASS IV.—STRAW-ELEVATORS WORKED IN CONJUNCTION WITH A THRESHING-MACHINE.**

Although this is the first occasion on which a prize has been offered for this class of machines by the Society, the straw-elevator has already become a most familiar, as well as valuable, appendage to the threshing-machine. The increasing difficulty of obtaining hands has secured a ready reception for all true labour-saving inventions, and among the most important of such recent inventions must be reckoned the elevator, which takes the place of at least two men, while adding considerably less than 1-horse power to the work performed by the engine threshing.

The labour of raising straw from the threshing-machine to the stack increases with the height of the stack, and will employ from two to four men at work that is rendered specially unpleasant by the dust that commonly envelopes the workers, and produces a craving for beer that makes it as bad for the morals of the labourer as it is costly to the farmer; it is, therefore, very desirable that no steam threshing-machine on hire should be sent out without the elevator.

By beginning their work in the yard each morning at 7 A.M., and continuing it until 7 P.M., the Judges had been able to complete the actual trials in Classes II. and III. by Saturday afternoon; they then commenced the trial of Class IV., but had only time to test one elevator (Wallis and Steevens, No. 4978) before the rain put a stop to all work in the yard, and afforded them an opportunity for continuing the comparison of notes, and taking the averages of their separate awards of points of merit,—a work that was in arrear in spite of conferences, continued every evening till ten, and sometimes until twelve o'clock. The rest of the machines in Class IV. were tried on Monday, the 13th, in the order given in Table VI. This table is not so full as we could wish; but, in the short time that could be given to these trials, and in the absence of the consulting engineers, who were unable to remain beyond the one week that had been intended for the trials, it was not possible to collect satisfactory information on every point.

Each elevator was brought into position, lowered as for travelling; a belt from the outer pulley on the shaker-crank of the threshing-machine, passing over the guide-pulleys, was then passed over the driving-pulley of the elevator; the elevator-trough was next raised for work to half its full height, the engine was then started, and the threshing and straw-elevating continued for as long a time as the Judges thought necessary. At a given signal the engine was stopped, the elevator was raised to its full height, and again set to work. As soon as this second run was finished, the machine was lowered and packed for travelling.

The ease and rapidity with which the operations of raising, lowering, folding, and unfolding, could be accomplished were considered as points of merit; but strength and simplicity of construction, and such a rigidity of parts as would secure the utmost regularity of work without the chance of any hitch, were considered the most important requisites in this class.

The nine machines entered for trial may be divided according to their construction into four sets. In the first set we have three machines with a trough of fixed length that does not fold for travelling; each of them has a four-wheeled carriage-frame. This frame is rigid in Nos. 4945 and 5027, but in No. 4757 it is made to expand in length.

In the second set we have four machines on rigid four-wheeled carriage-frames, but with troughs that fold up for travelling. In Nos. 4994, 5049, and 4848, the upper half of the trough folds over and rests upon the lower half; but in No. 4978 the upper part of the trough is doubled back under the other part when travelling.

TABLE VI.—LIST OF STRAW ELEVATORS TO BE WORKED IN CONJUNCTION WITH A THRESHING-MACHINE.

Catalogue number.	Name of Exhibitor.	Price.	Weight.	Height of delivery.	Length of Trough.	Height when packed.	Length when packed.
		£ s. d.	Cwt.	Feet.	Feet.	ft. in.	ft. in.
478	Wallis & Steevens	46 1 6	20	26	24	9 0	24 0
494	Tasker & Sons	45 0 0	40	24	28	7 2	19 0
4982	Nalder & Nalder	36 10 0	25	23	23	8 6	19 0
4848	Albert Weston	31 10 0	19	25	25	6 0	17 8
5027	Marshall, Sons, & Co.	48 0 0	37	21	22	10 0	..
4757	Russ, Morris, & Co.	39 0 0	15	20	20	9 0	.. <sup>1</sup>
5049	Stephen Lewin	50 0 0	32	25	31	8 1	17 0
4945	Clayton & Shuttleworth	49 0 0	30	23	22	..	..
4998	Tasker & Sons	32 10 0	20	22	28	10 0.	15 0

The third description of elevator, No. 4982, has a folding-trough on an expanding four-wheeled frame.

The fourth mode of construction is that of No. 4998, in which both extremities are made to fold back under the middle part of the trough, which, in travelling, is balanced upon a light two-wheeled frame. In describing the machines separately it will be noticed that the chief difference in principle of construction,

besides those that have been enumerated, is in the method adopted for raising and lowering the trough.

Fig. 20.—Messrs. Clayton and Shuttleworth's Improved Straw Elevator, No. 4945 (Hayes's Patent), lowered for travelling.

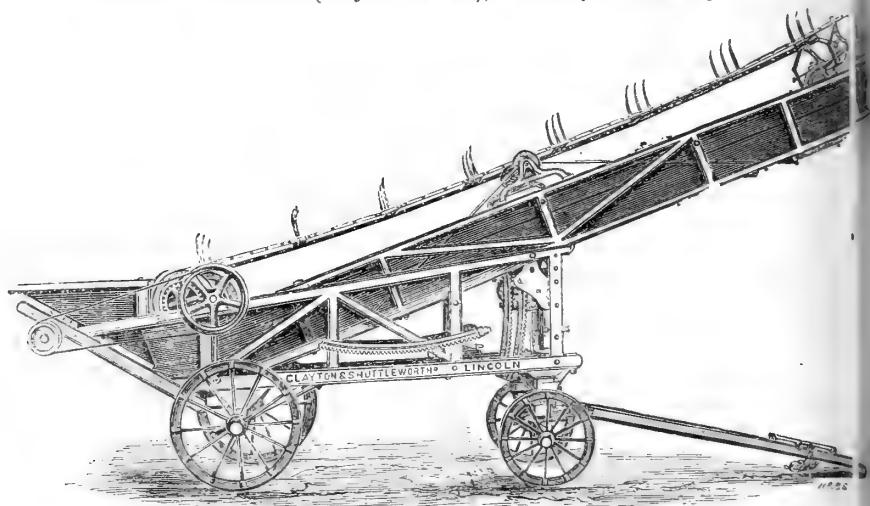

No. 4945. Clayton and Shuttleworth.—This is a very well constructed machine of Hayes's Patent, with no very important alteration of the original and well-known pattern, except that it is arranged to deliver at any angle, without requiring manual assistance to turn the straw into the hopper, which is now made round instead of square. This arrangement is introduced into many straw-elevators, and is of great importance, as an elevator that can deliver only in a straight line from the threshing-machine is often useless in the rick-yard. An open trussed wooden carriage-frame on four wrought-iron wheels carries the long wooden trough up which the straw is *pushed*, rather than carried, by long iron teeth fixed upon the wooden cross bars of the endless chain or flexible ladder. The lower end of the trough is suspended upon a shaft carried by plummer-blocks upon the carriage-frame, and made to revolve by means of a short belt from the shaft, which is driven from the threshing-machine. Upon the shaft and within the trough are keyed two octagonal iron pulleys having their sides of the same length as the iron links, which form the sides of the flexible ladder. Two similar octagonal iron pulleys carry the upper end of the ladder, which is also supported in the middle by two friction rollers.

The upper side of the revolving ladder descends in working, and is seen in Fig. 20; the lower and unseen side catches the straw in the hopper, and holds it down against the bottom of the trough while pushing it up to the stack. The under sides of the ladder are supported on three friction rollers set on each side of the trough. This mode of carrying the straw *under*, instead of *upon*, the teeth of the ladder is peculiar to the three machines which have the trough of a fixed length; in carrying straw it has the great advantage of securing it from being blown about by the wind, but it disqualifies these machines for use in stacking sheaf corn. The other machines are all

intended to do the double work of straw-elevators and stackers. The machine that is intended to do one thing only (like the man who confines his energy to one object) is generally the most formidable competitor in its own line. The engraving represents the machine as lowered for travelling. It is raised for work by means of two pinions, moved by a winch-handle, on the further side of the upper part of the carriage-frame; these pinions work into the two cast-iron racks placed above the fore-wheels. Two additional lengths of racks are placed ready for use in the centre of the frame. In the lower part of the bottom of the trough an open grating, four feet long, is placed so that any stray corns not extracted by the shakers of the threshing-machine, but separated from the straw in the process of elevating, may fall through and be subsequently collected. A similar grating is provided in the troughs of nearly all straw-elevators. The carriage-wheels are provided with patent axles, and the machine shows excellent workmanship in all its parts. The weakest point in its design is the use of the long cast-iron racks, which in frosty weather are apt to break if jarred in working.

No. 5027. *Marshall, Sons, and Co.*—This also is a very well made machine on Hayes's pattern, differing from the one last described chiefly in the arrangement for raising the trough. Two wrought-iron rods are hinged upon the fore part of the carriage-frame, these terminate in friction rollers, which run freely along metal grooves on the under sides of the trough; chains are carried from the upper extremities of these rods to a winch worked by the handle shown in front of the hind carriage-wheels; by turning this handle the chains are shortened and the trough is raised to the height desired. The only objection to this arrangement is that the chains at first starting work at a very acute angle to the rods, hence much of the power employed in raising is wasted, and there must be a considerable strain upon the winch. Three ribs are raised on the floor of the straw-hopper, and these serve to hold the straw up loosely, to be carried away by the iron teeth of the ladder which passes between these ribs. The whole of the framing is of oak; the wheels of the machine tried were of wood, 3 feet 4 inches in diameter, with patent axles. The sides of the octagonal pulleys and the links of the ladder chain are each 8 inches long. The spindles are covered with sheet-iron to prevent straws from wrapping round them. The machine is only suited for *straw* elevating, and can be worked at any angle. The workmanship is very good, and the construction very substantial.

Fig. 21.—*Messrs. Marshall, Sons, and Co.'s Straw Elevator, No. 5027.*  
(*Hayes's Patent.*)

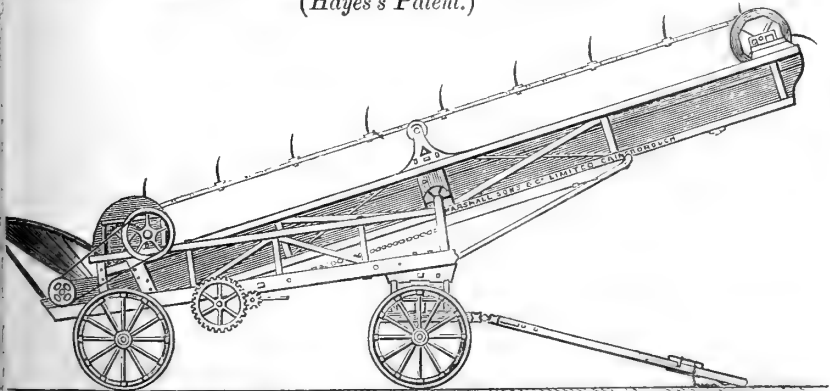

No. 4757. *Russ, Morris, and Co.*—This is a machine made, not by the exhibitors, but by Messrs. Stafford and Co., of Nassington, Wansford. The fore part of the trough is suspended from the upper extremities of two wooden shafts hinged upon the carriage-frame: these shafts are raised and lowered by chains passing from their heads round pulleys fixed outside the top of the hopper that receives the straw, and terminating in a winch on the carriage-frame. The straw can be delivered at any angle, and is elevated by a ladder-chain passing round octagonal pulleys. The carriage-frame is made to expand. The travelling wheels are of wrought iron, and rather slight; the weight of the whole machine is less than that of any other exhibited in this class.

No. 4994. *W. Tasker and Sons.*—This form of elevator is adapted for ricking hay and corn, as well as for elevating straw. It will be seen from the illustration given that the endless chain or flexible ladder passes round the

Fig. 22.—Lower portion of Messrs. Tasker and Sons' Elevator set for work.

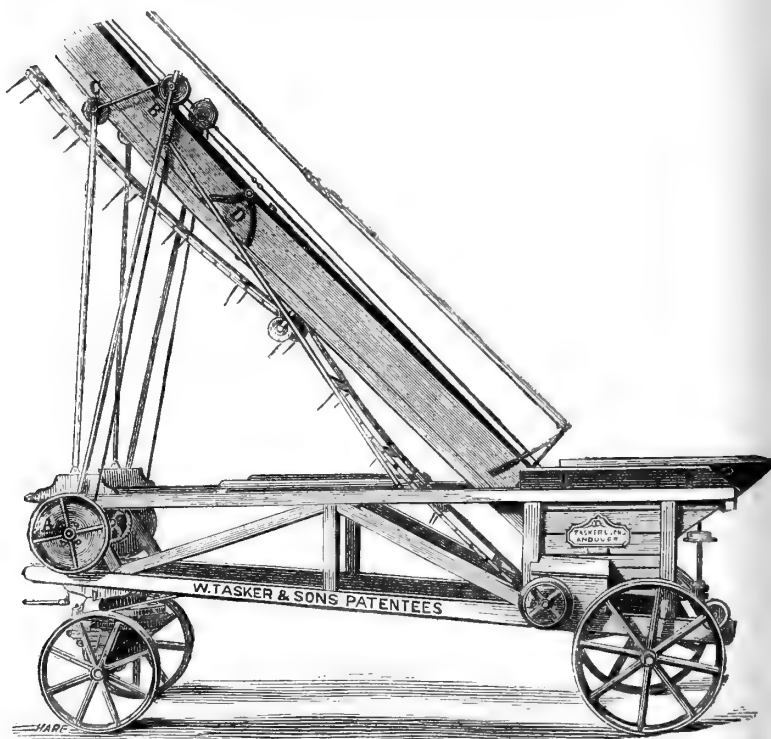

bottom of the trough, the straw is carried upon the teeth, and light ropes are stretched above the trough to prevent the straw from being carried away by wind. The apparatus for raising and lowering the trough consists of two wire ropes which are wound upon two small drums (one of which is seen at A); of two iron rods fixed to the carriage-frame above the drums, and secured by the truss-bar that passes down to the centre of the side frames, terminating in two pulleys as shown at B; and of two other iron rods which turn upon the bolts that hold them to the extreme front of the frame, while



at their upper extremity they carry friction rollers, C, which slide upon the under side of the trough. The end of the wire rope is attached to the upper end of the rod near C; it then passes over the pulley B to the drum A. By turning the handle placed in front of the fore-wheels, the rope is unwound from the drum, and the trough lowered to any height that may be desired. When the trough has been opened out for work, the joint at D is kept rigid by a joint-pin. To fold the trough up it is first lowered to a horizontal position, the joint-pin is then withdrawn, and the rope wound up till the folding part of the trough is upright, the rope then takes half a turn round the pulley B, and the upper trough passing between the fixed rods becomes suspended upon the rollers, C, and is gradually folded over as the rope is slackened from the drum. In folding up the trough, some weakness was observable at the joint, but the general construction of the machine is good, and it did its work fairly. It is furnished with a round hopper, and can deliver at any angle. The sides of the octagonal pulleys which carry the endless chain are shorter than those in the machines previously described, being only  $5\frac{1}{4}$  inches long.

No. 5049. *Stephen Lewin*.—This is adapted to work either by steam or horse power, and is precisely similar to the No. 5048 machine, which took a prize in Class V., and is there illustrated and described.

No. 4848. *Albert Watson*.—This is a cheap machine of very simple construction; it has a square hopper, and can deliver straw in a straight line or at right angles. A long and very light frame is carried upon four rather small cast-iron wheels. A pair of wooden shafts, 16 feet long, are fixed in a nearly vertical position above the two fore-wheels, and are capped by two pulleys, through which the chains for raising the trough are passed. A winch and pulleys in the middle of the frame wind up the chains; the ends of these chains are attached to the trough at a short distance above the joint, and the weight of the top of the trough thus tends to keep the joint wide open, so that no joint-pins are required. In folding up the trough it is first lowered, and the slack chains are shifted to the end of the trough; when they are again wound up, the upper half folds upon the lower, the upright shafts can then be taken down, and the machine is in a very compact form for putting away in a cart-shed. Short ropes for preventing the straw from blowing away are stretched over the upper part of the trough. The ladder-chains are light, and cogged chain-wheels take the place of the octagonal wheels that are more usually employed. The bottom of the trough is made of sheet-iron. The workmanship in this machine is rough, but the design is neat. The upright shafts need trussing, and means should be adopted to support the slack chains.

No. 4978. *Wallis and Steevens*.—In this machine the trough is carried between two trussed and oblique wooden shafts, and it is raised and lowered by means of a rack and pinion. One-third of the length of the trough can be folded down, the head of the trough being thus brought just in front of the fore-wheels. It is raised by means of an automatic apparatus formed of three pairs of iron rods, of which one pair is fixed to the fore part of the carriage-frame, one to the oblique shafts, and one to the folding part of the trough; when the trough has been raised for work, this apparatus is removed, and laid up on the frame of the elevator. The straw-hopper is square: the straw can be delivered at any angle, but the change from one angle to another is not accomplished with facility.

No. 4982. *Nalder and Nalder*.—One of Andrews' Patent Straw-Elevators, manufactured by the exhibitors. In this form of elevator the trough folds over, and is raised and lowered by drawing the fore-wheels to or from the hind-wheels. This form, though not commended as an elevator to be worked with a threshing-machine, was shown of rather lighter construction in Class V., manufactured by Messrs. Reeves. In that class it was highly commended, and will be found illustrated and described.

No. 4998. *W. Tasker and Sons*.—A Patent Folding Balance Elevator, with more originality in its design than any other elevator; it differs from all others

in this class in having only two travelling wheels of large diameter, and is remarkable for its lightness of draught and facility in turning. It stood in the ranks folded up among the other elevators for trial like a patent Hansom among four-wheeled cabs.

There are two joints in the trough, and the top and bottom parts fold under the middle, and are held by the same coupling-bars and links that serve to keep the trough rigid when it is opened out. The trough requires no carriage-frame, but is balanced upon the axle of the travelling wheels; it is raised and lowered by a simple arrangement of geared quadrants and pinions moved by a worm-spindle, the handle of which is shown in Fig. 23 in the hand of the attendant. The ladder-chains are driven by octagonal pulleys and supported on rollers; they are substantially made. The frame is of oak; and the straw can be delivered either at right angles or in a straight line. A machine precisely similar was tried and highly commended in Class V. For use in conjunction with a threshing-machine, however, it possesses the fault of not being capable of delivering the straw at any angle, and has not the great strength and simplicity in working which the Judges think desirable in this class. The strength of a chain depends upon the strength of its weakest link: in appending an additional link to a process already so complex as is that of threshing, it is of primary consequence that it shall be free from any weakness, for a single hitch will delay the whole operation.

Fig. 23.—*Messrs. Tasker and Sons' Elevator and Ricker, No. 4998, open for work.*



The following are the awards in this class:—

- No. 5027. Marshall, Sons, and Co. . . 1st Prize, 10*l*.  
 „ 4945. Clayton and Shuttleworth. 2nd Prize, 5*l*.  
 „ 4994. W. Tasker and Sons . . . *Highly Commended*.

It will be noticed that in neither of the prize machines is the trough made to fold up. Elevators used in conjunction with a threshing-machine are mostly employed all the year round, and are seldom out of use long enough to make it worth while to fold them up and put them away in an ordinary cart-shed.

CLASS V.—STRAW OR HAY ELEVATOR TO BE WORKED BY HORSE POWER.

The ten entries in this class consisted of 7 machine-elevators, and 3 small implements that acted as pitchforks, raised by ropes drawn by horses. If such implements are to compete for prizes on future occasions, it will be well to enter them in a class by themselves. When pitted against the more effective and expensive machines they had no chance of succeeding, although on small holdings and under special circumstances they may be found of great use where the other machines cannot be obtained.

All the machine-elevators brought for trial in this class were fitted with troughs made to fold up. Machines driven by horse-power are seldom used except for ricking hay and corn at harvest time; during the rest of the year they must be kept under cover, and unless the trough is made to fold up it will occupy a most inconvenient amount of space in the cart-shed.

TABLE VII.—LIST OF STRAW OR HAY ELEVATORS TO BE WORKED BY HORSE POWER.

Catalogue Number.	Name of Exhibitor.	Price.	Weight.	Height of delivery.	Length of Trough.	Height when packed.	Length when packed.
		£ s. d.	Cwt.	Feet.	Feet.	ft. in.	ft. in.
4978	Wallis & Stevens	{ 7 12 0 40 17 0 }	20	26	24	9 0	..
5048	Stephen Lewin	{ 8 0 0 50 0 0 }	32	25	31	8 1	17 0
4230	Holmes & Sons	58 0 0	35	27	35	10 0	25 0
4846	Albert Watson	{ 7 0 0 29 0 0 }	19	25	25	6 0	17 8
4946	Clayton & Shuttleworth	{ 7 0 0 45 0 0 }	27	27	..	..	..
4995	Tasker & Sons	{ 7 0 0 30 0 0 }	20	22	28	10 0	15 0
64	Reeves & Son	{ 7 0 0 30 0 0 }	18	..	28	..	..
964	Coleman & Morton	2 12 0	$\frac{1}{2}$	..	..	..	..
5798	W. T. Wright	11 10 0	4	..	..	..	..
114	H. Yorath	8 15 0	$3\frac{1}{2}$	..	..	..	..

The trial in this class consisted in making each machine successively elevate the same straw—a quantity of about a load, but not weighed. The time occupied varied from six to ten minutes, but is not recorded against each machine, as the feeding into the hopper was done by men who differed greatly in the rapidity with which they worked. There was no opportunity for testing the machines with hay, which from its greater weight would have been in some respects a better test than straw. In entering the prices of these machines, some of the makers included the price of the horse-gear required to work them. In the preceding table, for the sake of comparison, we have separated these prices where practicable, and have added the cost of the horse-gear to the prices given by the other makers.

No. 4946. *Clayton and Shuttleworth.*—The carrying-trough is made in two parts arranged telescopically, so that the upper part can, by means of a chain, be drawn down into the lower. This mode of packing for removal has the great advantage of avoiding the use of the hinges that can hardly fail to cause a certain amount of weakness in other troughs. The trough is raised by rack and pinion. The machine can be used in conjunction with a threshing-machine as well as for stacking hay or corn, and can deliver the straw at any angle. The workmanship throughout is excellent, and the materials used are of the same description as in the machine made by this firm described in Class IV.

Fig. 24.—*Messrs. Clayton and Shuttleworth's Improved Stacking-machine, No. 4946, for Straw, Hay, or Sheaf-Corn.*

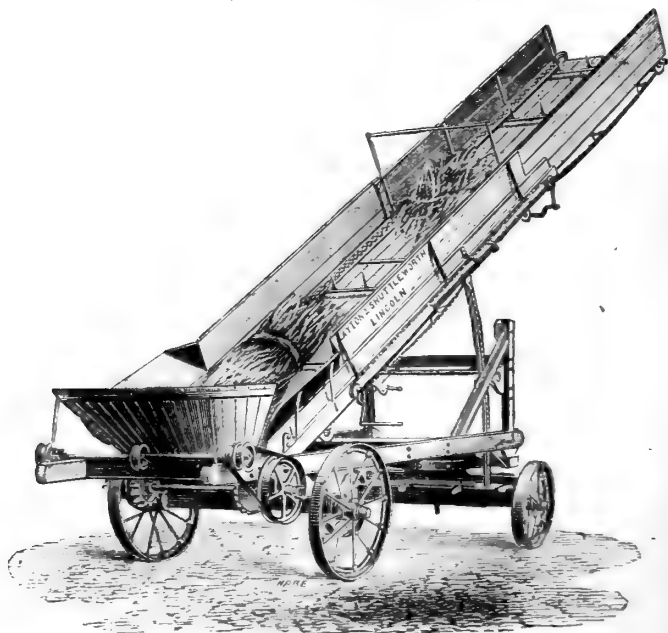

No. 5048. *Stephen Lewin.*—The carrying-trough is here of great length; the hinge divides it into equal parts. The apparatus for raising and lowering the trough is of great strength, but adds considerably to the weight of the machine. A handle placed behind the fore-wheels upon a worm spindle actuates a set of gearing which moves two toothed quadrants fixed upon the base of wooden shafts; friction rollers at the upper extremities of these shafts clip the angle-

Fig. 25.—*Lewin's Patent Stacker and Elevator, No. 5048.*

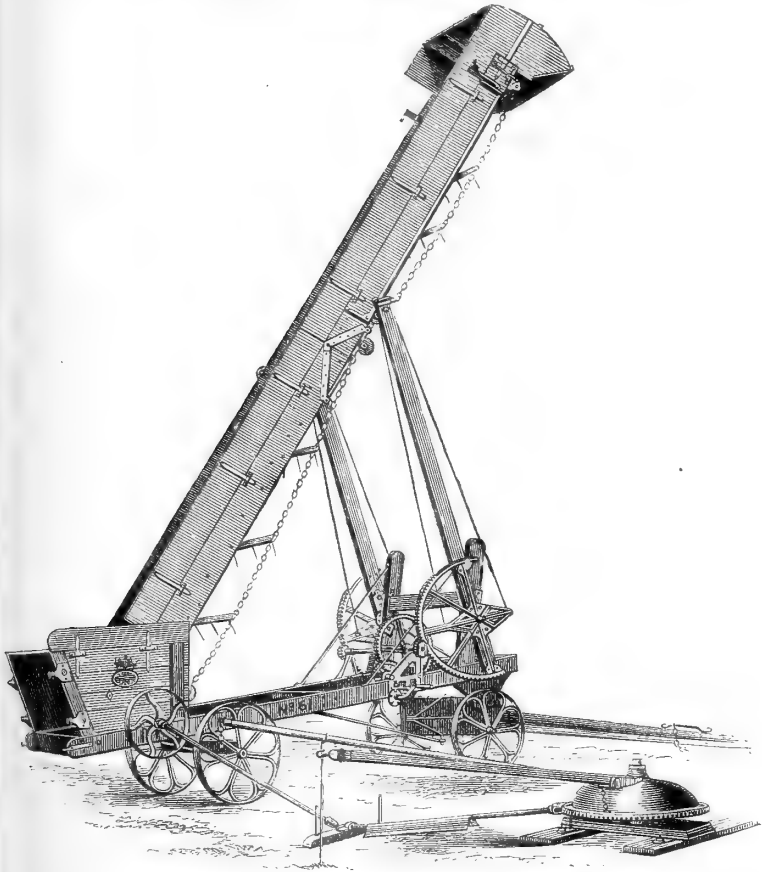

iron on each side of the trough. Spindles through the base of these shafts enable them to turn upon bearings fixed to a short frame placed above the fore-wheels. In folding up the trough these shafts are lowered with the upper part of it, and do not require any separate attention in packing. A "hood" and "weather-boards" are provided to protect the straw from the wind during its transit. The pitch chains of the flexible ladder are of alternate shut and flat links, and are driven by toothed chain-wheels. In this, as in most elevators, the horse-gear can be packed upon the carriage-frame for travelling. The slack chain is supported on two friction-rollers. The price is higher than

many of the other machines exhibited, but was stated to include delivery to all parts of Great Britain; it also includes the fittings required for working by steam in conjunction with a threshing-machine.

Fig. 26.—*Lewin's Patent Stacker*,<sup>†</sup>No. 5048, closed for travelling.

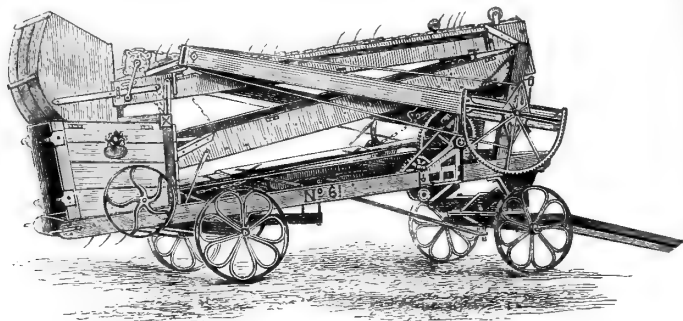

No. 4978. *Wallis and Stevens*.—The same machine as described in Class IV., except that the gearing required for working by steam had been removed, and that the folding apparatus was of wood resting on the ground, instead of being of iron supported on the frame of the elevator itself. These two alterations reduce the price of the machine by 5*l.* 4*s.* 6*d.*

No. 4846. *Albert Watson*.—A machine similar to the one described in Class IV., but without the extra pulley needed for working with a threshing-machine. In this trial the evil of using very slack chains not sufficiently supported was exemplified. Soon after starting the machine came to a dead lock, and several attempts were made to start it again before it was discovered that two of the links had been doubled up and were acting as a wedge between the toothed driving-wheel and the bottom of the carrying-trough.

No. 4230. *Holmes and Sons*.—This machine is constructed on the principle of the railway travelling-crane. The elevator frame and trough are raised above the carriage-frame, and are balanced upon a pivot passing through its centre. The horse-gear is, in this case, an integral part of the whole machine, and is placed between the carriage-frame and the frame of the elevator. The horse in working passes under the trough and within the two props that serve to keep the upper frame steady. The trough is raised and lowered by means of chains and rods. About one quarter of its length is made to fold under for travelling. The power is conveyed from the horse-gear to the octagonal wheels that move the ladder-chains by means of toothed chain-wheels and pitch-chains. The chief merit of this machine is the great facility with which it may be moved from place to place and set to work; the horse-gear being on the frame requires no adjustment, and the trough, having an independent movement, can be shifted by hand to deliver hay to any part of the stack without moving the carriage-frame. In its present form it has one serious disadvantage, it does not fold up into a moderate compass, but is very inconvenient to put under cover on account of its great length and height. Its workmanship and the materials used are good.

No. 64. *R. and J. Reeves and Son*.—This machine is the invention of W. Andrews, of Melksham, improved and manufactured by the exhibitors. It is of light construction and low in price. There are four travelling wheels, but no fixed carriage-frame; the trough is supported in front by a bolt passing through the heads of two wooden shafts, which are carried upon the axle of the fore-wheels.

The fore-wheels are 2 ft. 4 in. in diameter, with 3-in. tires; the hind-wheels 4 ft. 6 in. in diameter, with 2½-in. tires. The trough is raised or lowered by drawing together, or setting wider apart, the fore and hind wheels by means of chains and a windlass placed over the axle of the fore-wheels. The fore-wheels are blocked in position, and as the rick rises, the hind-wheels are drawn forward. This arrangement enables hay to be delivered near the centre of the rick when the elevator is at its full height, as well as when it is partially raised. The trough is divided into two nearly equal parts; these are held together by bolts, which also furnish bearings for the two arms which rise from the centre of the trough, and terminate in the double pulleys that carry the rope by which the trough is folded and opened for work. In folding up, the chain is wound up till the upper part of the trough has passed the vertical position; the chain passes from the right hand on to the left hand pulley, and, being once more slacked, the top is gradually lowered upon the bottom, the iron stays that have served to support the upright arms are then shifted, the arms are lowered, and the whole machine is ready for travelling, or for putting into the shed. The ladder-chains are driven by octagonal wheels. As there is no carriage-frame on which the horse-gear can rest for travelling, a pair of iron wheels and axle are provided for it, and it is attached by the pole to the back of the elevator.

No. 4995. *W. Tasker and Sons*.—Similar in all respects to No. 4998 described in Class IV., except that it is not fitted with the appliances required for working in conjunction with a threshing-machine.

The only machines that still remain to be described in this Class are the three forms of pitchforks, worked by horse-power. These were first tried on Friday the 12th June, and were set to elevate the loose haulm obtained in threshing out clover for the trial of the seed-drawers in Class VI. This material being short, dry, and loose, was not at all fit to be dealt with by the method adopted in Coleman and Morton's implement, and the work was best done by the double pitchfork, shown by W. T. Wright, while the Yorath single fork was not much inferior in its performance. Had hay been the material to be elevated, its greater weight and tenacity would have better suited the first-named implement, and the order of merit might perhaps have been inverted. The Judges regretted that they could not give these implements a more complete trial; but they felt that under no circumstances could they have had a chance of obtaining a prize when competing in the same class with machines that dispensed with the manual assistance required to guide them. A great difference occurs in the prices and weights of these three entries; but this difference is more apparent than real, as in the first instance only the fork and set of 3 pulleys are included, while in the other two the price and weight of the poles, ropes, and other appliances is added.

No. 964, *Coleman and Morton*, invented by E. Z. Walker, of the United States, and manufactured by the exhibitors. The fork or hay-holder consists of an iron rod, with a ring at one end for the hook of the pulley on which it is to be suspended, and at the other end a sharp-pointed shoe, which by means of a sliding rod and trigger, can be turned up at right angles to hold the mass of hay or loose corn into which the implement has been thrust by a man standing on the wagon or cart to be unloaded.

To use the implement, two rick-poles must be fixed firmly in the ground, and well stayed by guy ropes, one pole at the end of the stack, the other at a sufficient distance to allow the waggons to be unloaded midway between the two. One of the pulleys must be fastened at the top and another at the bottom of the pole furthest from the stack. A rope of one inch diameter is then passed through these pulleys, then through the swivel-hook pulley which is to carry the fork, and is stretched across to the other pole, to which it is fastened at a lower level than the pulley on the other pole, so that when tight it inclines towards the stack. A trace horse is attached to a whippetree at the other end of the rope.

Fig. 27.—*Illustrating the mode of working E. Z. Walker's Horse Pitchfork, No. 964.*

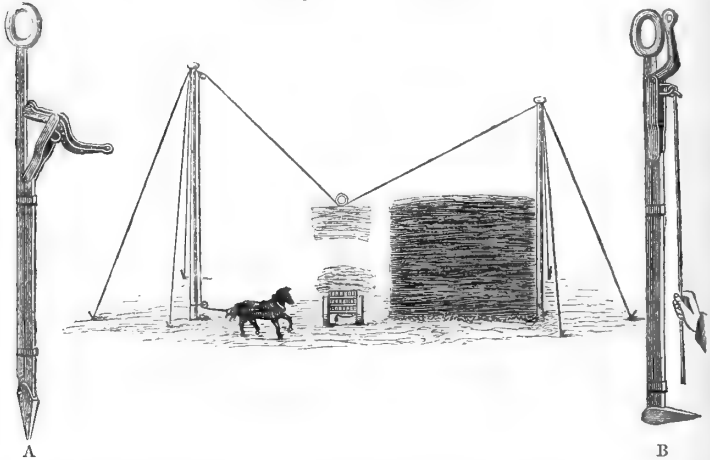

In unloading the hay or loose corn, the sliding pulley is drawn down to the top of the load; the man using the fork presses it into the hay as far as possible by the lever A (Fig. 27); the lever is then brought into a perpendicular position, so that the point of the fork forms a right angle, B; the fork is hooked to the pulley, and the horse being started the hay is raised, the pulley then slides along the rope to the stack. As soon as it reaches the desired spot the hand cord attached to the small eccentric lever must be pulled and the hay will be discharged upon the stack. Although quite unfitted to elevate loose clover-haulm, this small and cheap implement is coming into much use in this country, and has had a very large sale in America, 15,000 having been reported as sold in one year in the United States.

No. 5738. *W. T. Wright.* For this and the next implement only one rick-pole is required, held in position by 3 guy ropes. This pole carries a boom which is free to move round it, and which can be adjusted to any height by means of a rope passing through a pulley at the top of the pole. Upon the boom are two pulleys, as shown in the sketch, Fig. 28. The fork is suspended upon a rope, which passes over these pulleys round another pulley fixed near the bottom of the pole, and is then attached to the horse. The fork is double, formed of two curved three-pronged forks turned towards each other and fastened in the centre like a pair of scissors. The extremities of the handles are attached to two links, and these again are attached at their upper ends to a ring through which the elevating rope passes to the centre of the scissors or crab. The man who fills the fork on the cart holds a guide rope in his hand, by which



ne can swing the boom (while the fork is being raised by the horse) round the pole and over the stack. The fork is emptied by the ring, through which the rope passes, striking against a tappet at the end of the boom, when the scissors are of course opened. This form of fork we think better fitted for straw or cavings than for hay. The jar which occurs when the rope is suddenly stopped by the ring striking the tappet, would probably be very severe and objectionable when raising a large and heavy pitch of hay.

Fig. 28.

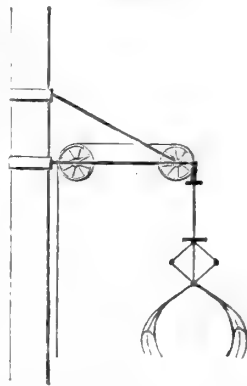

No. 114. *H. Yorath*. The general arrangement of pole, ropes, and shifting crane is similar to that adopted by the preceding exhibitor; but the fork, instead of being made double, is simply an ordinary pitchfork of gigantic dimensions, suspended from the elevating rope by a link passing through the base of the wooden handle; a guide rope is attached to the top of the handle and held by the man on the cart, who by means of it contrives to hold the loaded fork in a horizontal position and

at the same time gives it the necessary swing to direct the fork over the stack while the horse is drawing it up, and on slackening the guide rope the handle flies up and the load is thrown down. This fork did its work fairly, but it is a great objection to its use that the men on the stack will be constantly exposed to danger with a heavy implement with sharp tines, 3 feet in length, swinging close to them and not under the perfect control of the operator.

The awards in the Class were as follows:—

- |  |                          |
|--|--------------------------|
| 4946. Clayton and Shuttleworth .. .. . | 1st Prize, 10 <i>l</i> . |
| 5048. Stephen Lewin .. .. .            | 2nd Prize, 5 <i>l</i> .  |
| 4995. Tasker and Sons .. .. .          | Highly Commended.        |
| 64. Reeves and Sons .. .. .            | Highly Commended.        |

The Judges report that the machines, as a class, did their work very well. Although other considerations prevented their awarding the prizes to the cheapest machines, they think it desirable that, in the face of an increasing demand, the prices of such implements should be brought, as far as possible, within the means of all. A short time since, stacking by horse-power was only tried by those who could afford to make experiments in agriculture for the public good; elevators have now been long enough in use to justify their purchase by many who adopt the advice (in matters of business generally safe)—

“Be not the first by whom the new is tried,  
Nor yet the last to lay the old aside.”

In comparing the horse pitchforks with the machine elevators we may note it as an important point in favour of the latter that they do not require any erection of poles or ropes, an operation that is very inconvenient when it has to be repeated for each rick during harvest. At the same time it is only on large hold-

ings that sufficient advantage will be derived from an expensive elevator to repay the first cost quickly. There is no advantage in using an elevator until the stack has attained rather more than two-thirds the height of the loaded waggon, for until an over-head lift is required it is as easy to unload on to the stack as into the hopper of an elevator. With the horse pitchfork, on the other hand, some advantage is felt at an earlier stage, as the man on the cart has not to lift at all by hand. There does not seem to be any reason why elevators should not be employed to load the waggon in the field with hay that has been collected into windrows, since this is throughout an over-head lift.

Perhaps a modification of Tasker's two-wheeled elevator might be fastened to the tail of a waggon, and the straw chain be driven by gearing from the axle of the travelling wheels. We find that this notion cannot claim the merit, or demerit, of novelty, for such machines are used in America—a country that will probably continue to be in advance of us in mechanical invention so long as the stimulus of high prices for manual labour is supplemented by patent laws that afford greater facilities and fuller protection than our own. In estimating the advantages to be derived from an elevator, we must add, to the direct saving of labour, the further saving of straw and labour in thatching, that results from carrying the stacks higher, as well as the benefit of greater pressure upon the hay.

#### CLASS VI.—SEED DRAWERS.

Only three machines were entered in this class; they were driven by the same engine as that used in trying the threshing-machines, and with the same arrangement of the dynamometer. A small stack of clover-seed had been previously provided in the yard; this was headed by an ordinary threshing-machine a short time before the trials commenced. The cob thus obtained was of poor quality, containing a very moderate quantity of small seed, tough, and difficult to draw. The quantity of seed extracted in the trial was much less than the machines would have obtained in the same time if the crop had been of average quality.

Each machine was run for 15 minutes, and supplied *ad libitum* with seed in the cob. The results of the run are recorded in Table VIII. Although column 8 records a great difference in the number of revolutions per minute of each drum, there was probably but little difference in the speed of the drum peripheries, for the drum of Hunt and Tawell's machine was of much greater diameter than the others. The amount of power in column 13, it should be observed, is calculated per lb.

TABLE VIII.—RESULTS OF TRIALS OF SEED DRAWERS. CLASS VI.  
Tried 13th July, 1872.

Driving Rigger on Hand Dynamometer, 31 inches diameter.

1.	2.	3.	4.	5.	TRIAL.							13.	14.
					6.	7.	8.	9.	10.	11.	12.		
Catalogue Number.	NAME OF EXHIBITOR.	Price.	Weight.	Diameter of Rigger on Machine.	Amount of unseparated Seed served out.	Time occupied in Minutes.	Speed of Machine in revolutions per Minute.	Total Work done in Foot-lbs.	Horse-Power.	Weight of Seed separated, lbs.	Weight of Clean Seed after Winnowing, lbs.	Foot-lbs. of Work per lb. of Seed separated.	REMARKS.
4782	R. Maynard ..	£. s. 55 0 Jumper, 8 0	17	Inches. 8	As much in each case as could be treated in 15 Minutes.	15	981	1,569,000	3.17	..	..	..	These machines were tried on Red Clover Seed in poor condition.
4231	Holmes & Sons	53 0	30	8½		15	896	1,090,000	2.2	26½	21	41,132	A roughly-made machine. No seed separated. No result.
4492	Hunt, Reuben, & Tawell.	52 10	28	12		15	635	1,328,000	2.68	29	21	45,800	A fairly well-made machine. A fairly designed, but roughly made machine.

of seed extracted. If we wish to compare it with the power required to thresh corn we must, therefore, multiply the figures given in column 22 of Table III. by 3 (the weight of wheat being about one-third the weight of the sheaf corn); we then find that about five times as much power is required to shell out 1 lb. of clover-seed as is needed to thresh out 1 lb. of wheat. Probably this difference is greater than would have occurred if average crops of wheat and clover had been used for the trials.

The two machines that succeeded in extracting seed have each been recently improved in construction by placing the shelling barrel *under* the dressing apparatus; the power being applied close to the ground they now stand much steadier than they did with the barrel at the top of the machine. There is so little difference in the arrangement of parts in these two machines that the same drawings and description might serve almost equally well for either.

No. 4231. *Holmes and Sons.*—The construction will be best understood by referring to the illustrations given. The passage of the seed is indicated by arrows in the longitudinal section (Fig. 29). The pulley upon the right extremity of the shaft of the shelling-barrel receives the driving-belt from the engine. The drum (A B) is an open cone of 4 feet 10 inches long, bearing 8 wrought-iron twisted beaters; its greatest diameter is 18 inches, and it tapers to a diameter of 10½ inches at its smaller end; it revolves in a conical wrought-iron shell, the inner surface of which is grooved. The space between the drum and the shell is diminished by pushing the drum nearer to the small end of the shell. This is effected by shifting the pulleys at each end along the spindle upon which they are fastened by set screws. Two small reversible plates are inserted, one on each side of the shell; these have different groovings on each side; when a very vigorous action is required that side of the plate is turned inwards which is grooved in a different direction to the rest of the shell and the current of seed being diverted in its passage from one set of groove to the other receives an extra amount of rubbing.

The cob is placed in a trough on the further side of the machine, and is thence pushed by means of a small hoe to the centre of the broad end of the drum at A, and is drawn in by the current of air produced by its revolution this is an improvement upon the old method of feeding at the top, for the current of air then checked its entrance.

At B the seed falls from the small end of the shell into a receptacle, from which it is raised by a cup-elevator to the top of the machine; it then falls upon the riddle C, which removes all shivers, and conveys them through side spout into a sack. The seeds and chaff passing through the riddle fall upon the sieves at D, and there meet a blast from the fan E, which blow away the chaff, while the clean seed passes to the spout F, and is delivered into the sack; the hard hulks striking against the adjusting board G fall into the hopper of the shelling-barrel and are again passed through the machine. This machine worked very steadily, and with less power than was required by either of the others; the seed was thoroughly extracted, and without injury. The drum can be set to draw trefoil as well as clover.

No. 4492. *Hunt and Twell.*—The general design is similar to that of Holmes' machine, but the drum is of much larger diameter, and measures 18 inches at its smaller end. The conical shell was not well fitted, and seed escaped at the joints. A greater quantity of rough seed was delivered into the sack, but

the subsequent winnowing gave precisely the same quantity of clean seed—21 lbs. from each machine.

Fig. 29.—Illustrating Holmes and Sons' Seed Drawer, No. 4231.

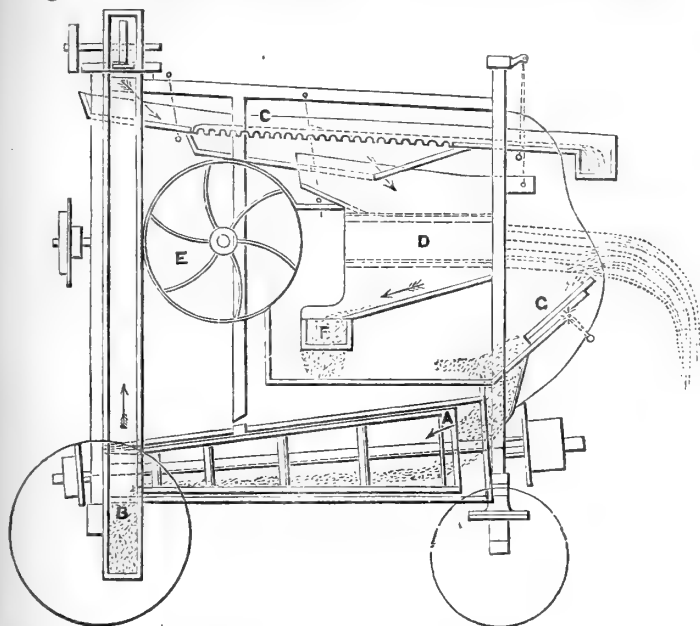

A. B. Drum.  
C. Riddle.  
D. Sieves.

E. Fan.  
F. Spout.  
G. Adjusting Board.

*Beaters*



*Section Shells*



No. 4782. *A. Maynard*.—This is a new implement brought to trial in a very imperfect state; it was fitted with a centrifugal elevator, and a jumper

intended to separate greybacks and other small seeds from the cob. This jumper is a wire-net screen worked on a principle radically wrong; instead of a lateral motion sifting the material along the surface, the screen is jerked perpendicularly up and down, the result being that all the interstices were very soon choked with the cob, and the whole surface bristled, till it resembled a very rough towel in appearance. Very little seed was separated by the drum, and the amount delivered into the sack was absolutely *nil*.

The exhibitor explained his total failure as due to the fact that the machine was new, and he had tested it beforehand with trefoil only, instead of red clover.

The superiority of its workmanship, and the low power required to drive Messrs. Holmes's machine, made the award of the Judges obvious, namely:—

4231. Holmes and Sons	..	..	..	1st Prize, 10 <i>l</i> .
4492. Hunt and Tawell	..	..	..	Highly Commended.

#### CLASS VII.—CORN-DRESSING MACHINES.

The entries in this class were more numerous than in any other. As the list first stood it contained 32 implements; a few of these were not sent in time for trial; others were disqualified by the Judges, as being implements sent by one maker with so very trifling a difference in arrangement or construction that they were virtually duplicates. To have allowed the latter to be tried would have been equivalent to giving more than one chance to the same machine in a competition so close that the results depended to a great extent on small differences of manipulation. After this reduction, 22 machines remained to be tried. Messrs. Clare and Sherborn began the trials in this class on Wednesday, the 13th; the working of the dynamometer and hand-power machine was superintended for Messrs. Eastons and Anderson by Mr. G. Neville. Each winnowing machine was in the first instance driven by a belt from the testing machine, travelling 66 ft. per second; the handle having been removed, a rigger to receive the belt was fixed in its stead, having its radius of the same length as that of the handle. The time and the power required to dress 130 lbs. of rough corn were thus ascertained: the machines selected for a second trial were not again tested by the dynamometer, but were worked in the usual way by hand; for the dynamometrical results were in this class felt to be of far less importance than the perfection of the separation effected, the goodness of the design and workmanship, and the moderate cost of the implements.

Pains were taken to obtain an uniform bulk of corn for the experiment by mixing the grain that came from several of the non-finishing threshing-machines; half a bushel of this corn was run through each machine as a preliminary to allow adjustments to be made. The 130 lbs. of corn weighed off for each trial was placed in three scoops ready for filling; the machine, with its feed-board set open, was then run empty till the right

pace was attained; at a given signal the corn was thrown into the hopper, and the time occupied by it in passing through duly noted. Samples were taken of the dressed corn and were set apart for a very careful subsequent examination and comparison. Ten machines were selected for a second trial, in which the pulleys were replaced by the handles, and the machines were worked by the exhibitors' men in the usual way. The time occupied in this second run is recorded in Table IX., p. 466, in column 11, and the awards given in column 12.

Among the twenty-two implements tried, there were very few that presented any novelty in construction. The great majority were of one pattern, differing only in minor details, and it will be sufficient to confine our remarks on construction to the prize implements, and one or two of the others that presented some special feature of interest.

Fig. 30.—*Coch's Corn-dressing Machine, No. 3148.*

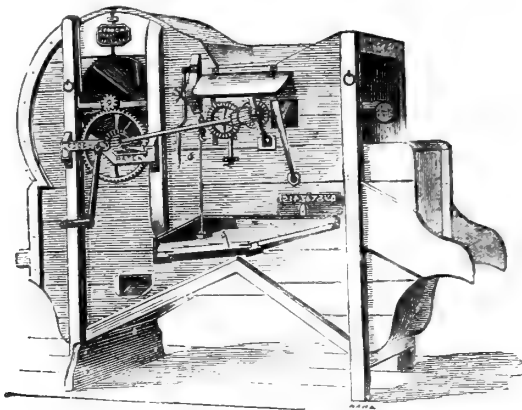

No. 3148. *J. Coch.*—In this machine the riddle-shoe is placed low in the frame, and the blast from the fan acts upon the corn as it falls from the hopper down to the riddle. The workmanship is throughout excellent, and the construction may be understood from the view given in Fig. 30. The handle is fixed upon a short driving-shaft bearing a spur-wheel with a small bevel-wheel in the centre; the spur-wheel gears into the pinion above it, and thus moves the fan fixed upon the shaft that carries the pinion. The opening through which the air enters to the fan can be diminished by lowering the slide-board, which thus regulates the force of the blast. The outside shaft from the bevel-wheel terminates in a cog-wheel, which gears into one or both of the two cog-wheels placed near the middle of the frame. These two cog-wheels are keyed upon the shafts of two feed-rollers placed at the bottom of the hopper. The feed-roller furthest from the fan is held in position by a lever balance-weight, shown inside the frame, at the opening for the escape of air and chaff. The feeding space is thus self-regulating; and if a stone has been shot with the corn into the hopper, it passes through without doing

TABLE IX.—RESULTS OF TRIALS OF CORN DRESSING MACHINES. CLASS VII. Tried July 10th, 1872.  
Driving Rigger on Hand Dynamometer, 31 inches diameter.

1.	2.	3.	4.	5.	6.	7.				10.	11.	12.
						FIRST TRIAL.						
Catalogue Number.	NAME OF EXHIBITOR.	Power required.	Price.	Undressed Corn served out.	Time occupied.	Revolutions of Machine per Minute.	Total Work done in ft.-lbs.	Work done in ft.-lbs. per Minute.	Foot lbs. of Work per lb. of Corn.	Time occupied.		
4233	Holmes & Son	..	£. s. d.	130	M. S.	38.7	8,158	3578	62.75	1.40		
3720	R. Boly ..	..	7 0 0	130	4.20	35.0	14,349	3311	110.37			
3147	J. Cooch ..	..	13 0 0	130	1.33	44.3	6,067	4322	46.66			
3730	R. Boly ..	..	12 0 0	130	2.4	23.9	6,582	2468	50.63	4.0		
4916	S. Corbett & Son	..	9 15 0	130	1.15	35.4	3,680	2944	28.30			
2072	Corbett & Cluphase	..	9 10 0	130	1.25	31.0	3,784	2683	29.10	1.25	Commended.	
3148	J. Cooch ..	..	14 10 0	130	1.37	42.5	6,107	3571	46.90	1.28	First Prize.	
3062	J. Rouse ..	..	9 10 0	130	1.29	37.8	5,793	3918	44.60			
869	B. Reid & Co. ..	..	8 10 0	130	4.53	37.9	2,635	1388	20.25			
3671	W. Sawney ..	..	11 10 0	130	0.44	43.3	3,347	4584	25.74			
3216	W. Nicholson & Son	..	10 10 0	130	2.13	41.3	9,256	4188	71.20	1.0	Third Prize.	
922	T. Corbett ..	..	10 10 0	130	2.0	21.0	2,356	1178	18.12	1.33		
4917	S. Corbett & Son	..	8 15 0	130	2.16	36.5	5,289	2340	46.84			
4155	W. Rainforth & Son	..	9 0 0	130	1.39	43.3	6,121	3709	47.07	1.3	Highly Commended.	
923	T. Corbett ..	..	8 15 0	130	1.19	37.5	3,714	2422	28.54			
4529	John Baker ..	..	8 10 0	130	1.18	36.2	8,397	6297	64.53	1.36	Commended.	
4532	John Baker ..	..	7 10 0	130	0.36	53.6	3,796	6327	27.15			
222	T. Baker ..	..	8 0 0	130	2.50	41.2	6,250	2205	48.07			
4618	R. Hornsby ..	..	16 16 0	130	1.45	36.8	6,101	3486	46.92	1.30		
960	T. Corbett ..	..	9 17 6	130	1.6	36.2	3,412	3101	26.23			
220	T. Baker ..	..	10 10 0	130	1.39	65.7	7,217	4373	55.51	1.21	Second Prize.	
870	B. Reid ..	..	9 10 0	130	0.26	66.9	3,308	7693	25.38			



damage. The index to the right serves for adjusting a slide-board that can be raised or lowered to allow less or more light corn to be carried over it by the blast. A connecting-rod from a crank on the unseen end of the fan-shaft oscillates the riddle-frame by means of a bell-crank with brass bearings. The frame is suspended upon iron links, and can be fitted with eight different riddles; those which are not in use are kept in a box placed between the handles of the machine. After passing through the riddles the corn falls upon an inclined screen, which delivers the head corn at the back, while the small grain falls through on to the floor under the machine, and stones, chobs, &c., are delivered through the spout at the side. Three sizes of screens are sent out with the machine. The handle is jointed and folds back when not at work, it is thus not liable to be wrenched in travelling. The hopper has recently been made lower and more open, and is therefore easier to fill than it used to be. It is a very striking illustration of the absence of any modern improvements on the old type of corn-dressing machines to find that the patent for this machine was taken in the year 1800, and though at different times the manufacturer has tried some alterations, he has returned to the old pattern, so that the machine only differs from those made more than 70 years ago in being more compact and in having iron substituted for wood in certain parts.

No. 220. *T. Baker.*—A lighter, simpler, and cheaper machine than that which took the first prize. The riddle-frame is in this case placed high up, and close under the hopper; the blast acts upon the grain while passing through the sieves. The bottom sieve is placed six inches under the top one, and a board is inserted obliquely between them, so that the blast shall be directed through both sieves. There is no feed-roller to the hopper, but it is furnished with a stirrer to keep the supply constant. The sieve-box is suspended on chains, and driven by a crank and connecting-rod from a bevel-wheel on the fan-shaft; by taking the bevel-wheel out of gear and removing the sieves, the machine can be used as a simple blower. The sieves are 22 in. by 16 in. From the sieves the grain falls upon an oscillating screen of wire-net, suspended on Coulson's spring hangers.

No. 3216. *W. Nicholson and Son.*—Very similar in design to Cooch's machine, but of simpler construction. The hopper is provided with one feed-roller driven by a belt from a pulley on the shaft that carries the handle; the riddle-box is moved by bell-cranks and a connecting-rod from the fan-shaft. Eight riddles and two screens are sent out with the machine. The materials and workmanship are substantial and good.

In *Rainforth's* machine the mouth of the feeding-hopper is regulated by a sliding-board with double rack and pinion, and may be fixed by padlock so that the workmen cannot enlarge the opening and pass the corn through too rapidly. It is furnished with an oscillating screen and is well constructed.

*Boby's* machines are fitted with his self-cleaning screen; one of them was used to test the samples obtained from the trials in the next class. *Hornsby's* machine was also fitted with his adjustable rotary corn screen. The First Prize was awarded to this maker for one of his screens in the next class.

The greatest novelty among the entries was the "Silent Winnowing Machine," No. 869, *B. Reid and Co.*, from the Bon-Accord Works, Aberdeen. All gearing is dispensed with, the riddle-shoe is moved by bell-wires from two cranks upon the fan-shaft; these wires terminate in leather thongs carried round two V-shaped pulleys and nailed to the shoe; the oscillating screen is moved by a similar arrangement. The enterprise of the exhibitors in coming so far south was not rewarded with success in this case, for the riddles and sieves used by them, though they might be fitted to deal with a small-berried north-country wheat, were too small in the mesh to make any separation of the grain used in trial, and we had no opportunity of judging whether the very quiet and easy movement of the riddles would be sufficient to effect the

separation desired. The strength and direction of the blast is regulated by a simple and ingenious arrangement of hinged boards.

The awards in this class were as follows :—

*Corn-dressing Machines.*—J. Cooch, Harlestone, Northamptonshire : First Prize, 15*l.* Thomas Baker, Compton, Newbury : Second Prize, 10*l.* W. N. Nicholson and Son, Newark, Notts : Third Prize, 5*l.* W. Rainforth and Son, Brayford Head, Lincoln : Highly Commended. Corbet and Chipchase, Shrewsbury : Commended. John Baker, Wisbeach : Commended.

#### CLASS VIII.—CORN-SCREENS.

The very general adoption of finishing threshing-machines has greatly increased the demand for rotary screens as a part of the machine, but has made it less necessary for each farm to be provided with its own hand-worked screen. As a separate machine, the screen is now perhaps of greater value to the maltster and miller than to the farmer ; but the latter still finds it often serviceable, and must always be interested in trials that test the qualities of a screen more perfectly than when it is tried merely as a part of the complex operation of threshing and dressing corn.

The nine machines tried were entered by six exhibitors, and may be divided into two classes—the plane and the rotary. The first and older form is represented by four machines, three of them entered by Mr. R. Boby, and one by Mr. T. Corbett. The corn in these screens is delivered spread over the upper part of a plane, more or less inclined, and formed of wire-net, or of stout longitudinal wires, fastened at their extremities and supported upon cross-bars.

In the five rotary screens the corn in each case is delivered into one end of a revolving wire cylinder, slightly inclined ; its descent is regulated in Coleman and Morton's machine by the peculiar shape of the wires, and in the other four machines by an Archimedean screw of sheet-iron, which prevents the too rapid descent of the grain, and distributes it evenly over the surface.

The machines in this class were tried in the same way as the corn-dressing machines ; they were first driven by a hand-power machine, and tested by dynamometer, and next tried without the dynamometer, and worked in the ordinary way by the exhibitors' men. Out of the nine machines tried in the first run, six were selected for three further trials ; these six machines comprised one by each of the exhibitors. 130 lbs. of wheat were used for each of the first three trials, and 100 lbs. of barley for the fourth. In the second, third, and fourth trials, half a bushel of corn was run through as a preliminary for adjusting the machines. Samples were taken of the head and tail corn from each run for subsequent examination. The head-corn was further tested by passing

one quart over a No. 8 hand-screen, and noting the inferior corn thus extracted. Two of the machines were provided with stone separators, but their efficiency in this respect was not put to the test, as the corn used in the trial was free from stones.

Nos. 3731 and 3734. *R. Boby*.—These two machines only differed in two respects, the first and higher priced one is much larger than the other, but was not fitted with the stone separator shown at the upper end of the screen in Fig. 31. The spur-wheel on the shaft that carries the handle drives the pinion below it. This pinion is keyed upon a crank shaft, and, by means of the forked connecting-rod fastened to the upper side of the screen, it gives a backward and forward movement to the screen, which thus slips up and down with a quick movement upon the chilled-steel slides which support it on the frame. The wires of the screen are kept clean by the action of six rows of cleaning collars, strung upon transverse iron rods that are fixed upon the frame-bed. The screen itself is composed of stout strained wires, placed horizontally upon bars, in notches punched by machine. The shape of these wires has recently been modified on the suggestion of one of the firm of Messrs. Bass and Co. After long usage, the sides of the round wires became worn, so that they had

Fig. 31.—*Boby's New Patent Self-cleaning Corn Screen, No. 3734, with removable Wire Part.*

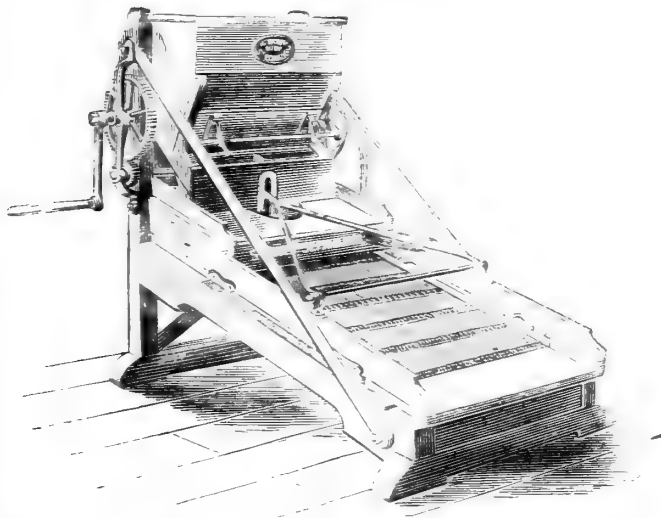

an oval instead of a circular section; the spaces between them being thus enlarged, it was necessary to reset the wires: the flattened wires, when once reset, presented a deeper wearing surface to the grain falling through them, and the spaces remained of the right size for a much longer time than when new wires were used. This observation has induced the manufacturers to use in the first instance wires with flattened sides, and the screen is now much more durable than it was. Another improvement has been made by arranging the screen and iron frame upon which it runs in such a way that the screen part can be lifted out and another of coarser or finer gauge fixed in its place. A sliding board at the bottom of the hopper regulates the feed space: the corn

TABLE X.—RESULTS OF TRIALS OF CORN SCREENS. CLASS VIII. Tried July 9th, 1872.

Driving Rigger on Hand Dynamometer, 31 inches diameter.

1. Catalogue Number.	2. NAME OF EXHIBITOR.	3. Power required.	4. Price.	TRIAL.						10. Work done in Foot-lbs. per lb. Corn.	11. REMARKS.
				5. Un-screened Corn served out.	6. Time occupied in Minutes.	7. Revolutions of Machine per Minute.	8. Total Work done in Foot-lbs.	9. Work done in Foot-lbs. per Minute.			
3731	R. Boby .. .. .	..	£. 9 9	lbs. 130	1.45	35.4	4872	2952	37.47	First Prize, 10l.	
2291	Penney & Co. .. .. .	..	12 12	130	1.43	68.5	7457	6961	57.36	Highly Commended.	
965	Coleman & Morton .. .. .	..	14 10	130	1.15	59.0	3783	3026	29.10	Highly Commended.	
4152	W. Rainforth & Son .. .. .	..	14 14	130	1.46	41.9	6485	6688	49.88	Highly Commended.	
925	T. Corbett .. .. .	..	8 5	130	1.18	37.1	2469	1899	18.99	Commended.	
3732	R. Boby .. .. .	..	8 10	130	1.04	40.0	..	..	..	Corn works machine by gravity.	
4617	R. Hornsby .. .. .	..	12 12	130	1.30	78.9	6553	4368	50.40	Second Prize, 5l.	
3732	R. Boby .. .. .	..	8 17	130	1.41	55.4	2135	1270	16.42	Commended.	
2292	Penney and Co. .... .	..	13 13	130	1.39	49.8	5851	3546	45.00	Commended.	

falls from the hopper into the stone separator—a box fastened upon the screen-frame, with a bottom of wire-net of large gauge; this intercepts all foreign substances larger than the grain, and delivers them out of a spout at the side. The corn passing through the meshes of the separator then descends over the surface of the screen in a thin broad stream, rippling over the cleaning collars: this rippling action changes the position of each grain, and gives it a longitudinal direction in its passage, greatly facilitating the extraction of thin and broken grains.

Fig. 32.—*Boby's New Patent Self-acting Corn Screen.*



No. 3732. *R. Boby.*—A self-acting machine, worked by the weight of the grain acting upon a breast-wheel placed between the hopper and the screen. Two cranks upon the axis of this wheel are on each side connected by rods to two light frames, each carrying four rows of the cleaning collars; these working between the wires of the screen keep them clean. No attention is required beyond that of keeping the hopper supplied with grain, and it is recommended as a great economiser of labour.

The idea is novel and ingenious, but not of much practical value in its present mode of application; it affords, however, a simple illustration of the significance of the figures given in column 10 of Table X. These figures show that the other screens varied, in the power required to drive them, from 16 to 50 foot-pounds per pound of corn screened, the manual labour being expressed by the height in feet from which the corn would have to fall in order to produce force enough to do the work. In this machine the work is actually attempted to be done by raising the bottom of the hopper about *one* foot above the top of the screen, and then introducing a wheel to utilize the force so obtained.

It is at once obvious that there must either be a great waste of power in the other machines, or that the power employed in this case is not nearly enough to secure efficient work. In all the other machines, the screen itself either oscillates

or revolves beneath the grain; in this case the power is all expended upon moving the cleaning collars, and the pitch of the screen is of necessity made so sharp, that the barley falls rapidly down over the surface by its own weight. But little of the tail-corn was extracted. There is, of course, no absolute saving of manual labour in using such a machine for corn lying on the barn floor; the power that moves the collars must be first expended by the man who lifts the corn an extra foot high in filling the hopper. If he lifted the corn 16 feet higher, there would be power enough to move the screen itself, and by suitable mechanical contrivances the work might be done thoroughly, but the man would be doing double work. The only case in which such a machine seems likely to be useful is where the grain to be screened lies on an upper floor, and a sufficient fall can be obtained without extra labour: even there, an overshot or a breast-wheel to utilize a fall approaching 16 feet would be far too cumbersome to be suitable for the small weight of the grain. A turbine-wheel is well suited to utilize a small fall of water in similar cases, and might perhaps be employed economically for grain in large granaries.

No. 925. *Thomas Corbett*.—This machine was fitted with a blower to remove light substances from the corn as it passes from the hopper to the screen, but by the direction of the Judges the mouth of the fan-box was nailed up during trial. The screen is flat, and composed of small wires woven to form a square mesh; it is suspended upon slings, and can be raised or depressed at its lower end. By thus altering the pitch of the screen, the grain passes more or less quickly over its surface. It is made to oscillate by two connecting-rods, driven by crank-wheels upon the fan-shaft. A long-handled brush, of the full breadth of the screen, is worked by hand up and down its underside. This brush worked stiffly, and required a better method of attachment to the handle.

No. 4617. *Hornsby and Sons*.—The screen is fitted with a blowing apparatus; but it was not used in the trial, and the machine consisted simply of the hopper and the cylinder of coiled wire, with a small stone separator at its upper end. The grain falls from the hopper first into the stone separator, a wire cage with coarse meshes revolving with the screen: an Archimedean screw of sheet-tin carries the stones backwards and upwards and delivers them through a spout at the back. The screen is a cylinder of coiled wire, wrapped round a frame composed of light iron rods, arranged diagonally, and terminating in the rims of two castings carried upon a central shaft. The coiled outer wires are bound by wire stitching to the diagonal rods, and, by a recent improvement, a loop of the stitching-wire is introduced between each of the main wires of the screen, thus wedging them apart and preventing them from slipping upon the rods. The screen is adjusted by a handle on the end of the central shaft. This handle moves the lower casting up or down a slot on the upper side of the hollow shaft, by means of a screw inside the shaft. The casting that forms the upper end of the cylinder is free to revolve between two collars upon the shaft. Thus, when the handle is turned to set the screen closer, the lower casting slides up the shaft and the upper casting is pushed by the thrust of the diagonal bars, so as to turn over from left to right. When this screen was first brought out the passage of the grain was regulated by the action of the diagonal bars only, but the screen brought for trial was fitted with a large sheet-iron Archimedean screw, similar to those used in most other rotary screens. The exterior of the cylinder is a plain surface, the spaces between the wires are kept free from obstructions by a long brush resting upon the upper side of the screen, and hinged upon the outer frame.

Nos. 2291 and 2292. *Penny and Co.*—The screens made by this firm have long been popular with the manufacturers of threshing-machines, and were more used than any other in the threshers entered for trial.

In each of these screens the cylinder is formed of a continuous coil of iron

wire, terminating in the rims of two iron castings, one of which is fixed and the other movable upon the shaft by means of a central screw, similar to that in Hornsby's screen. To secure regularity in the spaces between the main wires, twelve barrel springs of fine steel wire, running the full length of the cylinder, are affixed to it by wire stitching. In the No. 2291 machine these springs are placed inside, while in No. 2292 they are placed outside the main cylinder. The second of these is the older, and, in the opinion of the Judges, the better arrangement. When the springs are outside it is necessary to leave three spaces in the brush frame to avoid the springs, and the brush must be driven by spur-wheel and pinion; but the interior of the cylinder is a plain surface, and the corn, guided throughout its passage by an Archimedian screw, is always in contact with the screening surface. On the other hand, when the springs are inside they are perpetually lifting the corn, so that much of it falls from one spring to another, and is only partially brought into contact with the true screening surface. There is a simplicity in this arrangement that at first sight is taking, for the exterior of the cylinder being plain, the revolving brush is also made plain, and rotating by friction needs no gearing to drive it. The trial proved that this simplicity, however, was obtained at the cost of efficiency, and the older form of screen was the only one selected for a second trial.

Fig. 33.—*W. Rainforth and Son's Adjustable Rotary Corn Screen, No. 4152.*

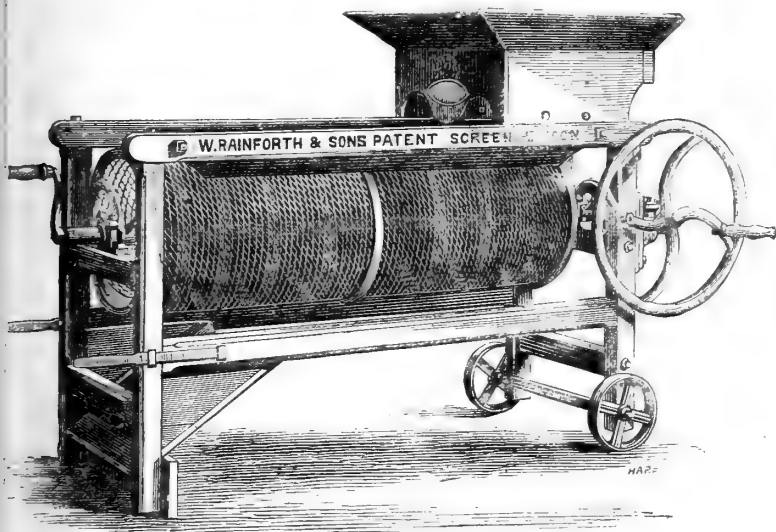

No. 4152. *Rainforth and Son.*—The cylinder of this screen is made of one entire piece of woven wire-work, with meshes that diminish in size by changing from the square to the diamond shape as the cylinder is shortened. Both ends of the wire net-work are fixed in the rims of iron castings. There are three of these castings; the upper one is fixed, the centre and lower one slide in slots, in the central hollow-shaft, and are moved by a central screw. The two ends of this screw have threads of a different pitch, and by this means the meshes at the feed end of the screen are always closer than those at the delivery end. No springs or lapping wire are needed, and as the screen

is woven of No. 18 wire there is a larger screening surface in proportion to the length than in screens made of stouter wire. The lightness of the cylinder is remarkable, and would hardly lead one to expect that it could withstand, without permanent injury, the violent treatment to which one of these screens was subjected in Messrs. Marshalls' threshing-machines, or that it could so easily be restored to perfect working by rough and ready means available on any farm. A stone separator is provided as in Hornsby's screen. The corn is guided down the screen by a sheet-iron Archimedian screw. The cylinder is 16 inches in diameter, and at its full length measures five feet long. A revolving brush outside the screen rotates by friction, and serves to remove the corns that are caught in the meshes.

No. 965. *Coleman and Morton*.—This screen differs altogether in its construction from the general type of rotary screens, it is externally a twelve-sided

Fig. 34.

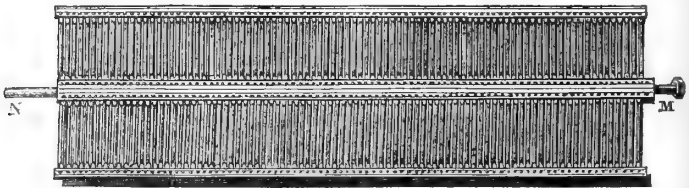

barrel, composed of six double sections. One of these sections is shown in the upper illustration, and consists of a steel mid-rib and two outer bars of steel, connected by a series of cross bars, loosely riveted at each end. The construction of the screen is shown in the lower figure, where the meshes have been set as closely as possible, and three of the double sections have been removed to show the position of the parts.

Fig. 35.

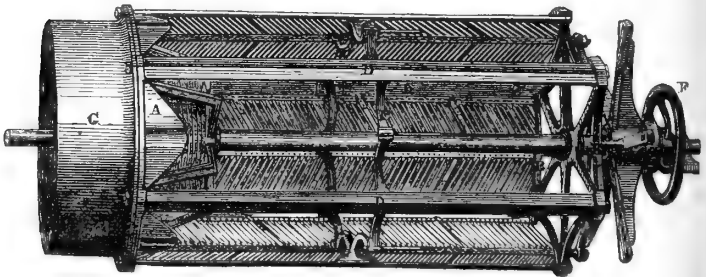

The main frame consists of three castings, A, B, and C, carried upon the central spindle; two of these castings, A and B, are keyed to the spindle, and connected together by six longitudinal bars, D, bent to the proper angle to form a twelve-sided figure, and secured in the middle by being riveted to the central ring, E. The third casting, C, has six arms, which receive the heads, M, of the mid-ribs; it slides with a play of 4 inches upon the spindle, and is moved by the hand wheel, F. The pin, N, at the other end of the mid-rib, slides through the flange of the casting, A; an eye under the centre of each mid-rib slides upon the pins attached to the centre ring, E. The outer bars



of the double sections are furnished with springs, which clasp the longitudinal bars, D. In setting the screen the mid-rib is drawn out or pushed back longitudinally; the outer bars of the section only move laterally and are nearest together when the cross bars are in an oblique position and the screen set close. G is a light cast-iron drum for receiving the corn from the hopper; it is bolted to the casting, A, which also carries the stone separator through which the grain falls in its passage to the screen itself.

The small cross-bars of the screen are of a triangular shape, so that its interior presents a series of small ridges-and-furrows. The trough shape of the outlets for the grain facilitates the delivery of whatever is small enough to pass through the spaces. The continuity of the stream of grain is broken by the diagonal position of the cross-bars and the edges of the longitudinal bars, but it is somewhat deeper than in the screens that are fitted with an Archimedian screw. It is noticeable that this screen did not clear itself for some time after the supply of corn had ceased to run into it, this indicates that it is only the upper layer of the stream that moves freely down the barrel, by sliding over the corn beneath it; although the corn that is uppermost at one time will be undermost at another, it is better that each grain should be in contact with the screening surface, as far as possible, throughout the whole of its passage. It is in this point that the superiority of Mr. Boby's screen was most marked. Although the length of screen surface traversed by the grain was in the rotary screens more than six times their diameter, and far greater than in the oscillating screen, yet in the latter the stream was rarely more than one grain deep, and the separation more thoroughly effected. None of the work, however, in this class was badly performed, and it will be noticed that all the machines tried more than once are commended.

A recent improvement has been introduced in this screen by the substitution of a leather roller in place of the revolving brush; the roller is held against the outside of the screen by curved springs, and is raised by each angle of the twelve-sided barrel passing under it; it thus cleans the screen by a constant succession of slight taps upon each of its sides.

The awards in this Class were as follows:—

*Corn Screens.*—Robert Boby, Bury St. Edmunds: First Prize, 10*l.* Richard Hornsby and Sons, Grantham: Second Prize, 5*l.* Coleman and Morton, Chelmsford: Highly Commended. W. Rainforth and Son: Highly Commended. Thomas Corbett, Shrewsbury: Commended. Penney and Co. (Limited), Lincoln: Commended.

### MISCELLANEOUS ARTICLES.

The introduction of the rule that prevents any commendation of miscellaneous articles lessens considerably the apparent results of the labours of the Judges in this class; but, although the record of their observations is confined to those articles that obtained a Silver Medal, the labour of inspecting each of the 308 stands of implements was one that needed great patience as well as good judgment. After examining implements of all sorts and sizes, from the powerful stone-breaker down to the delicate lemon-squeezer, they found, during the first two days of their work, but two implements of fitting merit. Subsequently they had better success, but, after trying several other novelties,

they confined the award of Silver Medals to the six implements named below.

No. 4659. Ransomes, Sims, and Head. Patent Drum adapted for Threshing Machines.

No. 4591. Clayton and Shuttleworth. "Wilders" Patent Self-feeding Apparatus for Threshing-Machines.

No. 888. Benjamin Reid and Co. Patent "Disc" Broadcast Sowing-Machine.

No. 1986. Lawrence and Co. Patent Capillary Refrigerator for Cooling Milk.

No. 4972. Marsden and Co. "Blake's" Patent Stone Breaker.

No. 3599. Barford and Perkins. Patent Adjusting Screws for Setting Engines square with Threshing and other Machines.

The first two of these inventions have been already described in the report on threshing-machines.

Fig. 36.—*Sams's Patent Disc Seed-discharger, No. 888.*

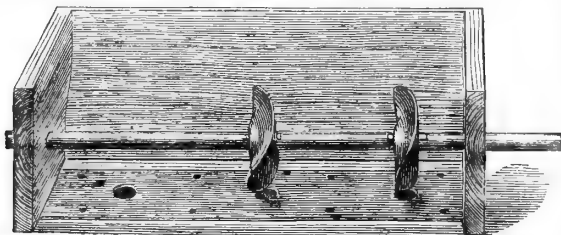

The Sams's Patent Disc Seed Discharger exhibited by *Messrs. B. Reid and Co.*, of the Bon-Accord Works, Aberdeen, shown in the accompanying cut, is a very simple and efficient substitute for the cups and brushes commonly used in drills and seed distributors. The disc is waved, so that in each revolution four deliveries of seed are made into the hole beneath it; the size of these holes is regulated by a sliding bar with similar holes adjusted beneath the seed-box by means of a handle in the middle of the machine. The broadcast sowing machine in which these discs were exhibited has other merits in its construction, and was tested on a wet and muddy part of the Show-yard where it delivered its seed very evenly, and worked to the satisfaction of the Judges. The seed-box is 12 feet long, made in one piece and very strong; it is hung between 2 wheels of 4 feet 6 inches diameter. These wheels revolve upon an axle 13 feet 6 inches long; by means of a ratchet and paul this axle only revolves as the machine *advances*, so that no seed drops out in turning at the headlands; the seed-box being beneath this shaft is nearer the ground than in most machines with smaller wheels, hence it can be used in windy weather, and is yet very light in draught. A quick stepping horse will sow 18 to 20 acres a day. Upon the middle of the carriage-shaft a spur-wheel is keyed, and works by double gearing into a spur-wheel upon the disc-shaft that revolves in the bottom of the seed-box. The intermediate spur pinions can be put in and out of gear by means of a lever handle in the centre of the box. When working up or down hill the seed is sown at the same pace without any adjustment. For travelling along a road the two land-wheels are removed from the long axle on to a short cross axle in the middle of the box, and the shafts are removed from the centre to one end of the box. Two sizes of discs are used, a large one for grain and small seeds, a small one for beans, peas, and other large seeds. The price of the machine to sow 12 feet, with road carriage, is 147. 10s.

No. 1986. *Lawrence and Co.'s Patent Capillary Refrigerator* has been much used by brewers for cooling beer. It will be found of very great value to farmers who sell their milk for consumption in towns, and in summer may be used in the dairy to cool the milk as it comes from the cow before setting it for cream. In sending milk by rail or road it is of the utmost importance that it should be thoroughly cooled as soon as it leaves the cow; this is sometimes done by immersing the milk churn in a running stream, but where there is no suitable stream at hand it has been a matter of considerable difficulty to cool the milk sufficiently without loss of time. In this apparatus a very small quantity of cold water, passing upwards in a very thin stream between two corrugated sheets of metal, rapidly abstracts the heat from two very shallow streams of milk descending outside the metal sheets. In Fig. 37, D is the inlet, and E the outlet for the water, which, being supplied from

Fig. 37.—*Lawrence and Co.'s Patent Capillary Refrigerator.*



a higher level, flows through the refrigerator, B, by the force of gravity. A tap in the milk receiver, A, regulates the flow of milk into a small trough at the top of the refrigerator punctured with holes, through which the milk runs, and is spread into so fine a sheet that, instead of falling rapidly from step to step, it follows the corrugations of the surface. The attraction is thus not capillary, as the name of the apparatus might lead us to suppose, but simply one of adhesion. In the enlarged section (Fig. 38) of a part of the refrigerator the descending arrows indicate the currents of milk gradually cooling as they descend; the current of water passing upwards is gradually warmed, so that when it passes out of the spout at E it is very nearly of the same temperature as the milk in the receiver.

Fig. 38.



The stone-breaker invented by Eli W. Blake has been for some years exhibited in the Show-yard by *Messrs. Marsden and Co.*, and has proved its efficiency in breaking up granite and other stones to a size suitable for road metal. It has hitherto been open to the objection that, the stones being always cracked in the same direction were not brought into the best shape, but, by a recent improvement in the shape of the jaw, the stone is now cubed, and an excellent sample of road metal is prepared with far less waste of material. The contrivance for cubing the stone by means of a cross-bite is shown at A (Fig. 39, p. 478), near the bottom of the jaw, and still more clearly in the front view (Fig. 39, 2), where it will be noticed that the partially broken stone, instead of descending in one straight line, will be thrown sideways by the change in the grooving of the surface of the jaw. The

movable jaw is suspended upon a pin, B; and is moved by the rocking lever, C, held by the pin, F, between the two toggles, D and E. The thrust is upon the lower part of the jaw, and is greatest when the lever is in a vertical position and the two toggles are in the same straight line. The pin, F, which gives support to the lever, is carried in two horizontal slots in the side frames. Good roads are one of the first requisites of good farming, but the scarcity of labour has of late made it very difficult to get the road metal reduced to a proper size at moderate cost. When every large quarry is provided with a good stone-breaker the work of the road surveyor will be simplified and the cost of road-making much reduced.

Fig. 39.—Blake's Stone-breaker.

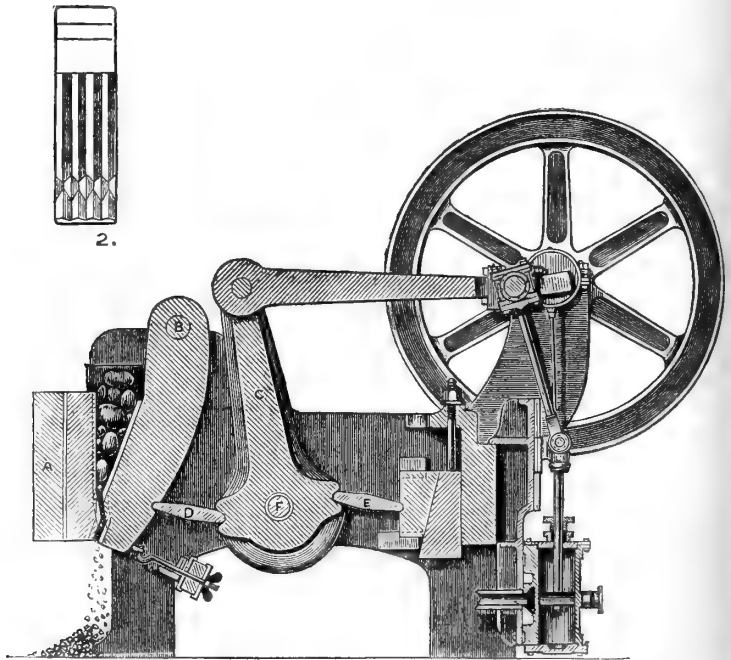

The last on the list of Medals awarded is given for a simple and valuable contrivance for avoiding the loss of time and labour that frequently occurs in setting the portable engine to work. It is an easy matter to run the engine at once *very nearly* into the position required for driving a threshing-machine or a windlass for steam ploughing, but the last few inches of the adjustment often require an amount of pushing, pulling, and lifting, that on soft ground may strain the implements as well as men and beasts. If ever a Society should be established for the Prevention of Cruelty to Machines, a contrivance like this might well compete for a Medal. The object of the contrivance is to shift the position of the engine upon the fore and hind carriages without moving the wheels: this is done by transverse screws that can be easily fitted to an ordinary engine. Fig. 40 gives the front elevation of the engine—one of Clayton and Shuttleworth's make—a female screw is cut in the head of the bolt in the middle of the fore-carriage, a long screw of coarse pitch is then

passed through the bolt-head, with free-bearings in the sides of the bracket that carries the smoke-box; a slot of 18 inches is cut in the bottom of the bracket; by turning the crank handle of the screw the bracket with the engine resting upon it can be shifted upon the axle plate 9 inches to the right or left of its usual position.

Fig. 40.

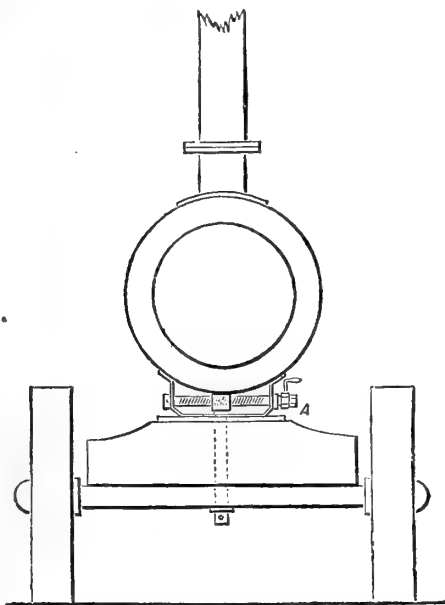

A similar arrangement is adopted to move the hind part of the engine, which is carried in the usual way by 2 vertical brackets upon the axle of the hind wheels. These brackets, instead of being fixed, are made to slide upon the axle; a strong bracket is fixed upon the middle of the axle, and a long screw works through the head of this bracket, having free bearings in the upper parts of the 2 vertical brackets fixed to the engine. By these means the engine driver can, without any further assistance, adjust the fly-wheel of his engine exactly to the line of the driving pulley on the threshing machine or windlass. The cost of applying this improvement to both the axles of an engine is 10*l.*; but in practice it may be sufficient to apply it, at the cost of 5*l.* to the fore-axle only.

Another excellent labour-saving device was exhibited in the light endless rope attached to the handle of the stop-valve of this engine, and carried round two pulleys at the corners of the fire-box to the front of the windlass or other machine to be driven. This adaptation of reins to the steam horse enables the man who is attending to the machine to shut off or let on the steam by pulling the right or left hand cord as easily as if his hand were directly in contact with the handle. It would be well perhaps if, in other respects, our engines and other implements were treated more like horses; were they cleaned and tended with the same care that is spent in grooming horses their efficiency and longevity would, on some farms, be much increased.

XXII.—*Report on the Plans of Labourers' and Miners' Cottages competing for the Prizes offered in connection with the Cardiff Meeting.*

FORTY-TWO sets of plans of cottages for agricultural labourers, and fourteen for miners, were sent in competition for the prizes offered by the Marquis of Bute and Major Picton Turberville, but the Judges regret that there were none which they would like to send forth with such a stamp of approval as the obtaining a prize at the Royal Society's Show would convey. There were none possessing sufficient merit to entitle them to such a distinction; the best were copies of that known as the Leeds Plan, but without its simplicity and efficiency; and experience has proved that cottages upon that plan cannot be built for the stipulated sum of 220*l.* per pair. The Judges would suggest that in offering prizes again for plans for agricultural labourers' cottages, no maximum cost should be fixed, but that the prizes should be offered simply for the best plan combining simplicity, economy, efficiency, and architectural effect.

Although there was no set of plans which the Judges could commend as a whole, there was one (No. 40, entered by Mr. Hine, Foreman of the Patent Brick Works, Worcester), which in its arrangements both of living and bed rooms possesses a simplicity, originality, and convenience, which may be worked into something very useful; but the elevations given cannot be approved of. The Judges recommend that, with the sanction of the designer, this plan be published in the Society's 'Journal,' leaving out the elevations.

And as to miners' cottages, there is no plan which appears to be free from grave objections and therefore none which the Judges would like to have considered a model for imitation; consequently in this class, as in that for agricultural labourers' cottages, they recommend that the prizes be withheld; and they venture to suggest for publication, a plan in use upon some mining properties in the north of England, which seems to provide sufficient accommodation at the smallest possible outlay.\*

C. RANDELL,  
THOS. SAMPLE,  
GEO. HUNT.

---

\* The publication of these plans and the Report of the Trials of Portable Steam-Engines has been unavoidably postponed.—ED.

XXIII.—*Report of the Proceedings in the Court of Exchequer in the case of Kidd v. the Royal Agricultural Society of England. Before Mr. JUSTICE BLACKBURN and a Special Jury.\* Leeds Summer Assizes, August 7th, 8th, and 9th, 1872.*

[THESE proceedings arose in the following manner:—

On March 6th the Chemical Committee presented to the Council their usual Quarterly Report on Manures and Feeding-stuffs, which had been submitted to the Consulting Chemist for analysis since the previous December. This Report was published in the 'Mark Lane Express' for March 11th. One paragraph, which is repeatedly quoted in the following pages, then gave rise to the following actions:—

Kidd *versus* The Royal Agricultural Society,

Kidd *versus* Alger (publisher of the 'Mark Lane Express'),

Ayre *versus* The Royal Agricultural Society,

Ayre *versus* Alger,

the defence of all of which was undertaken by the Society, but

Kidd *versus* The Royal Agricultural Society, and

Ayre *versus* The Royal Agricultural Society were alone proceeded with.

These actions, with another of Kidd *versus* The Yorkshire Conservative Newspaper Company (arising out of the publication of the same paragraph in the 'Yorkshire Post'), were set down for trial at the last Leeds Summer Assizes, and the first of them was tried at Leeds on August 7th, 8th, and 9th. The following Report of the Proceedings (taken from the shorthand notes of Messrs. Martin and Meredith) was, on the recommendation of the Journal and Chemical Committees, ordered to be published in the Society's Journal by a Special Council, held on August 21st, by order of the President of the Society.—EDIT.]

FIRST DAY.

*Counsel for the Plaintiff.*—Mr. SEYMOUR, Q.C., and Mr. CAVE (instructed by Messrs. ROBERTS and LEAK of Hull.)

*Counsel for the Defendants.*—Mr. FIELD, Q.C., and Mr. MELLOR (instructed by Messrs. GARRARD and JAMES of London.)

Mr. CAVE opened the pleadings.

The declaration stated "that the Plaintiff carried on the business of an oil and seed crusher, and the Defendants at divers times and on divers occasions falsely and maliciously printed and published of the Plaintiff, in relation to his said business, the words following, that is to say:—'During the last quarter very few samples of artificial manure have been forwarded for analysis; of those sent to the consulting chemist he has no complaint to make. As usual at this season cases of so-called poisoning from the use of cakes have

\* John Gowland, of Thorpe Underwoods, farmer; John Foster Horsfall, of West Croft House, in Haworth, Esquire; Thomas Johnson Hughes, of Great Georges-street, in Leeds, brassfounder; Joe Illingworth, of Bramley-lane, Lightcliffe, in Hipperholme-cum-Brighouse, merchant; John Jackson, of Mowbray Hall, in Gruelthorpe, farmer; Charles Johnson, of Bierley Hall, in North Bierley, wine and spirit merchant; William Kelsall, of Coleridge-place, in Bradford, merchant; Joseph Richardson, of Ousegate, in Selby, draper and grocer; George Shaw, of Bridge-street, in Sheffield, victualler; James Shepherd, of Vale House, Todmorden, in Stansfield, manufacturer; Edward Sutcliffe, of Roe Head, in Mirfield, corn miller; Benjamin Wood, of Claremont, in Warley, ironfounder.

been brought under his notice, the first to be mentioned is from Charles O. Eaton, Esq. \* \* \* \* Another case comes from John Wells, Esq., February 18th, a Member of our Council, the whole of whose cattle were attacked with serious symptoms immediately after eating from a fresh purchase of cake, although only one case terminated fatally. This cake very much resembled the cake sold to Mr. Eaton, containing a quantity of seeds, cotton cake, rice, broken corn and cocoa-nut, apparently made from dirty linseed and the sweepings of corn warehouses. A small sample of this cake had been sent before purchase to Mr. Wells as best linseed cake, price £10 per ton, from Ayre Brothers, Hull, the maker, Messrs. Kidds, of Hull' (meaning the Plaintiff), the "Defendants thereby meaning that the Plaintiff had made and supplied to the said Ayre Brothers, as and for best linseed cake, a bad and inferior linseed cake made from dirty linseed and the sweepings of corn warehouses; and also that the Plaintiff had made and supplied to the said Ayre Brothers, as and for linseed cake, a cake containing ingredients of a poisonous nature, and injurious to cattle, whereby the Plaintiff was injured in his credit and reputation as an oil and seed crusher, and in his said business. And the Plaintiff claims one thousand pounds."

The Defendants pleaded—1st, Not guilty; and 2nd, That the defamatory matter complained of was true in substance and in fact.

Mr. SEYMOUR stated the Plaintiff's case as follows:—May it please your Lordship, gentlemen of the jury. The Plaintiff in this case, Samuel George Kidd, carries on an extensive business at Hull as an oil manufacturer and seed crusher. You will probably be aware that a very important element of industry has sprung up in connection with the agricultural interest of this country in the supply of linseed cake, which is manufactured from the residue which remains after expressing the oil from the linseed imported from abroad; and the town of Hull has become very well known as the site of large works connected with this industry, throughout England and foreign countries.

Now, gentlemen, my client, Mr. Kidd, has brought this action in order to vindicate his trade—his brand, if I may so speak—and his name from the consequences of a most serious libel, the responsibility for which will not be disputed by the Defendants, the Royal Agricultural Society of England, who, I believe, to day have instructed their Counsel to admit, and have admitted in the proceedings, that they are responsible for the document, which I will presently call your attention to, which forms the subject of our complaint, and which appears in the columns of the 'Mark Lane Express,' which, as you know, is one of those papers especially devoted to the circulation and publication of subjects connected with agriculture, and interesting to the farmers of England.

Gentlemen, I need hardly say that in opening this case to you, so far as Mr. Kidd is concerned, he brings his action purely to vindicate his own reputation, which he has maintained for a considerable number of years by carrying on, as I have told you, a very large and prosperous business, both in oil and linseed cake. With regard to the Defendants, it will be said, and said truly, that they are a highly honourable and most important body; and while, no doubt, on the one hand, this is a case in which Mr. Kidd seeks to vindicate his character at your hands; yet, on the other hand, I should be the last man to impute to the Defendants as a body that their conduct was at all influenced by any personal malice, or any wrong or indirect motive so far as Mr. Kidd is concerned; but, gentlemen, I need hardly say that the charter which has made the Royal Agricultural Society a corporate body, has not necessarily made them infallible. They have their subordinates and agents, their secretary, their chemists, their solicitors; and in questions of this kind the responsibility must bear on a public body like the defendants as upon other employers



of labour throughout the country (without any malice or indirect motive on their part being suggested) for the acts of their subordinates and agents on whose judgment they rely.

Now, with these remarks I will proceed to read to you that of which we complain. It will scarcely require any comment of mine to show that it is that which is known as a libel in law; for anything which is written and published disparaging to the honour or character, or tending to lower the reputation of another, or, as in this case, affecting the trade of the person who is made the subject of it, is, in the eye of the law, a libel. Gentlemen, what I hold in my hand purports to be a report of the Royal Agricultural Society of England, and it was published in the 'Mark Lane Express and Agricultural Journal' of March 11th, 1872—published therefore under the sanction of the Society—published so as to receive at once a very high authority and a very extensive circulation. The paragraph to which I wish to call your attention is headed "Quarterly Report of the Chemical Committee" (that is the Committee who report to the Council of the Royal Agricultural Society)—"During the last quarter very few samples of artificial manure have been forwarded for analysis. Of those sent to the consulting chemist he has no complaint to make. As usual, during this season, cases of so-called poisoning from the use of cakes have been brought under his notice. The first to be mentioned is from Charles O. Eaton, Esq., Toletorpe Hall, Stamford." Now I need not tell you, as later on the whole of the libel will be before you, that this is a complaint from a Mr. Eaton with regard to some evidently bad linseed cake which he had received, which led to widespread mischief amongst his cattle, and on which the opinion of a veterinary surgeon was given that some of the cattle were poisoned by the cake. It then proceeds:—"The cake contained much earth-nut, also locust meal, rice-dust, grass seeds, broken corn, and the usual small weed seeds found in inferior or dirty linseed, and was altogether a bad linseed cake." Well now, gentlemen, having introduced the matter as one of a class of "so-called poisoning," and of "bad linseed cake," it then proceeds—and this is the passage of which we complain,—"Another case comes from John Wells, Esq., February 18th, a member of our Council," I make no comment upon that further than to say, that probably in the case of a member of the Council of the Society, if there was an extra caution to be applied, so far as the secretary was concerned, one would have commended him for it; because it is possible that when members are the complaining individuals it might affect the judgment of those who are brought in contact with them—"the whole of whose cattle were attacked with various symptoms immediately after eating from a fresh purchase of cake, although only one case terminated fatally. This cake very much resembled the cake sold to Mr. Eaton, containing a quantity of seeds, cotton cake, rice, broken corn, and cocoa-nut, apparently made from dirty linseed, and the sweepings of corn warehouses. A small sample of this cake had been sent before purchase to Mr. Wells as best linseed cake, price 10*l.* per ton, from Ayre Brothers, Hull—the makers Messrs. Kidd, of Hull." Now, gentlemen, it requires no comment from me to ask you to agree that the obvious import and result of that paragraph which I have just read to you is this, that here is another case "of so-called poisoning"—another case "of bad linseed cake," like that of Mr. Eaton's, which was pronounced very bad indeed, and then it speaks of its having led to "serious symptoms," and to the cattle being "attacked." Serious symptoms of what? Why, of poisoning, as I venture to say, is implied by the use of deleterious cake containing, more or less, either poisonous or injurious ingredients; and leading to one attack which terminated fatally. It is obvious that any one reading this would infer that the attack of the cattle, and the fatal result in the one case of these serious symptoms was attributable to the compound which, as best linseed cake, is said to have been supplied by Messrs.

Kidd. Then you have the distinct allegation that it contains these various seeds and foreign elements,—cotton cake, for instance; and also that it is made of “dirty linseed” and “the sweepings of corn warehouses.”

Gentlemen, as soon as this appeared, Mr. Kidd was at once aware of the terrible mischief which a report like this, coming with the stamp of a Society like this upon it, cast upon the world and circulating among the very people who were his patrons and customers, must probably produce. What he feared has in effect followed; because I shall prove to you directly that there has been a very serious diminution of orders from the habitual customers since this libel appeared, with regard to that particular sort of cake referred to, and therefore this is really a case in which, if I am entitled to your verdict, my client is entitled to a verdict which will compensate to him the loss which he has sustained, and which I shall be able to demonstrate to you. As soon as this appeared my client placed himself in the hands of his solicitors, Messrs. Roberts and Leak of Hull, who wrote to the Secretary of the Society, and a correspondence of some length passed with which I am not going, in my short opening statement, to trouble you. It will be a part of the case: it will be referred to by me as far as is necessary, and by my friend; but there are one or two comments which I think I ought to make on matters which are disclosed in that correspondence. It is made the subject of complaint on our part, and rightfully I hope you will think, that there was no communication—no letter written for explanation or otherwise—by the Secretary, or any official of the Royal Agricultural Society, to Mr. Kidd before this paragraph appeared, or before his name was associated with it. One would suppose that the Royal Agricultural Society might have published, without parading the name of Mr. Kidd in connection with this attack upon the production of his mill, the result of their analysis; one might suppose that they would in all fairness to him have given him the opportunity, by personal explanation, or by putting them upon the course of enquiry, of modifying in some degree that which they had written. However they have not done so—I make no further comment upon it, but I think you will agree with me that before they took this extreme course which, although they may have been animated by the best public motives, they must have known would have the effect of injuring another, they ought to have communicated with the individual before mentioning his name.

Gentlemen, there is another matter which I think I ought to refer to, because, in the form which this case takes, it has an important bearing upon it. This action being brought to recover compensation and to vindicate the Plaintiff's character from the consequences of this libel, the Defendants take this course: they plead, first, it is not a libel; they put me to the proof of the publication, and of the meaning and import of the words; and they say it does not come within the definition of a libel, as to which I venture to submit our affirmative proposition to my Lord's approval. I think there will be no doubt about that; and upon the other point possibly less doubt; but, further, the Defendants do this—they put on the Record an affirmative plea alleging that that which they have asserted is true. Now, bearing that in mind, I am making this comment on this correspondence: they assert that this is the report of a Chemical Committee, founded no doubt on chemical analysis, as to the character of which, and the care with which it was made and the general character of which, we shall hear something before this case is over; but I think you will agree with me that when the solicitor of the Plaintiff applied three or four times over to the solicitors and representatives of the Defendants, they ought, in common justness and fairness, to have been furnished by the representatives of the Royal Agricultural Society, with a sufficient quantity of the article impugned to enable them to have another open and independent analysis made; but although that was prayed, although we asked that they would let

us have a sufficient portion of the cake, in order that some analyst and professor of skill and experience might have in his hand a portion of that which they have impugned in this article, they have, upon various grounds, refused it. They first asked us, "What is your object in making this request?" Well, I should think our object would be pretty plain. Then they suggest this: "We have got a distinguished chemist" (who is no doubt responsible for this Chemical Report), "Dr. Voelcker: let him join with some other person and make a joint analysis." But, Gentlemen, it is obvious that such a course would have been fruitless. If our analyst had been certain to agree with Dr. Voelcker, well and good, but how could you have a joint analysis if the two analysts differed at the time they were making it? What we wanted was that some independent third person should make an analysis, but that opportunity was not afforded us. I make this remark because in these cases the counsel opening the Plaintiff's case, where there is a plea of justification on the record, has two courses open to him: he may either grapple at once with the plea of justification and endeavour beforehand to demolish the structure which is threatened to be set up by the other side, or he may take another course; and I must say, looking at the fact that the Defendants have deprived us of the opportunity of having an analysis made of this cake, and thus left us in the dark as to the particular course which my friend is going to take, as to how far he will prove the allegations which are alleged—I must say, as the burden is upon him of proving that which he asserts, I think the better way of dealing with this case will be to let the responsibility rest upon him, and when he makes out a case which calls upon me for an answer, I will venture to accept his challenge, and then I have no doubt, before the case is over I shall be in a position to prove that the charge which has been made by the Agricultural Society against the Plaintiff in this action—however praiseworthy the motives of the Society may have been—is without foundation, and that Mr. Kidd supplied to the gentleman named in the libel, not that which was deleterious to the health of the cattle, but a good nourishing cake equal in quality to that which has hitherto enabled him to gain the confidence of thousands of customers and farmers from one end of England to the other.

The 'Mark Lane Express and Agricultural Journal' of 11th March, 1872, containing the Quarterly Report of the Chemical Committee and the libel complained of, was then put in and read, and the correspondence between the solicitors on each side, of which the following letters are the most important:—

16, Bowlalley Lane, Hull, 15th March, 1872.

SIR,—We have been consulted by Mr. S. G. Kidd, of Hull, seed-crusher, with reference to the statements made in the Quarterly Report of the Chemical Committee of your Society as to cake alleged to have been made by him. We have to inform you that the statements in such Report, so far as refers to our client, not only generally but in all their details, are simply untrue.

The Report sanctioned by the high authority of your Society is doing and must do our client incalculable injury, and our client has no alternative but to seek the redress and public refutation of the statements which a judicial investigation alone can afford.

The publicity given to your Report in many of the leading papers of the kingdom renders it impossible that mere retraction of the statements can purge the effect which, to the injury of our client, they have produced. We are, however, desirous to avoid anything of a vexatious character in the matter, or personal annoyance to your Chemical Committee or other members of your Council, and therefore write to you to be furnished with a copy of the Report, and to know if your Society will take the responsibility of the publication of

the Report and answer the proceedings which, on behalf of our client, it will be our duty to adopt. If, however, our request is not complied with by return of post, we shall have no alternative but at once to adopt legal proceedings against your Chemical Committee and other members of the Council in our own justification, informing them of our previous application to you. We cannot, however, assume for a moment that your Society will not be prepared to take the responsibility of this Report, and so relieve us from causing personal annoyance to its members. We shall hope to hear from you, or from the Solicitors to the Society, by return of post.

We are, Sir, your obedient servants,

The Secretary,  
Royal Agricultural Society,  
Hanover Square, London.

G. C. ROBERTS and J. LEAK.

March 16th, 1872.

GENTLEMEN,—I have to acknowledge the receipt of your letter in reference to a Quarterly Report of the Chemical Committee of the Council of this Society, which contained a statement respecting a sample of linseed-cake said to have been made by Messrs. Kidd, of Hull. This letter I will lay before the next meeting of the Council. In the meantime I beg to inform you that the Society is responsible for the publication of its own proceedings and the Reports of its Committees, as furnished by the Secretary. An official copy of the Report will be forwarded to you in the course of a few days.

I am, Gentlemen, your obedient servant,

H. M. JENKINS, *Secretary.*

Messrs. G. C. Roberts and J. Leak.'

13, Suffolk Street, Pall Mall East,  
London, 28th March, 1872.

Royal Agricultural Society *ats. Kidd.*

Alger *ats. Kidd.*

DEAR SIRS,—We have entered formal appearances to both these actions. The Society is actuated only by motives of public good in publishing the Reports of its Chemical Committee, and holds itself responsible for the publication in the 'Mark Lane Express' of the Report of which your client complains. His action, therefore, against Mr. Alger, the publisher of that paper, is clearly unnecessary for any real good to himself, and should, we suggest, be at once discontinued, to prevent useless expense.

On this point also we would call your attention to an editorial note in last week's issue of that paper in reference to the publication of the Report in question.

In publishing its Report the Society is most desirous to avoid any just ground of complaint, and wishing to act in all fairness towards your client and to prevent unnecessary litigation, we have now on the Society's behalf to offer him the opportunity of testing the correctness of the analysis made by the Society's Consulting Chemist (Dr. Voelcker) of the cake in question, from further samples of it in the Society's possession, by any other gentleman of equal professional standing, and to publish the result, if desired, in the same way as Dr. Voelcker's analysis, with any further explanations that may be necessary. Kindly let us hear from you on these points.

Yours faithfully,

GARRARD and JAMES.

Messrs. Collyer-Bristow, Withers, and Russell,  
4, Bedford Row, W.C.

Hull, 10th June, 1872.

*Kidd v. Royal Agricultural Society.*

*Kidd v. Alger.*

DEAR SIRS,—We have deferred replying to your letter of the 28th March last until we have been able to get the whole of the facts connected with these actions before counsel.

After full consideration of the matter we are prepared to stay all further proceedings in the action of *Kidd v. Alger*, the costs already incurred to abide the event of the action against the Royal Agricultural Society, if you will agree to an admission that the Society authorizes the publication of the Report in the 'Mark Lane Express,' and are responsible, in order that such admission may be given in evidence against them.

We are compelled to decline the offer you have made of having the correctness of the analysis tested in the manner suggested by you. Looking at the facts of the case, the circumstances under which the libel was published without any communication with our client or asking any explanation, the circulation the libel has obtained, and the injury it has done and must do our client, the course you propose cannot be deemed satisfactory.

We, however, have to apply to you for a sample of the cake which you have in your possession, and we shall be glad if you will make up and seal the same, so that the cover may be properly identified at the trial.

We have also to request that you will be good enough to furnish us with a copy of the analysis of Dr. Voelcker, on which your client's Report is founded.

We propose forthwith delivering the declaration in the action against the Society, laying the venue in Yorkshire, so that the trial may come on at the next Assizes for Leeds. We will delay delivering the declaration in *Kidd v. Alger* (which is already prepared) for a week from the present date, for your reply as to the admission proposed.

Yours truly,

G. C. ROBERTS and J. LEAK.

Messrs. Garrard and James,  
13, Suffolk Street, Pall Mall East, London.

Mr. ALGERNON SYDNEY AYRE sworn: *examined by Mr. CAVE.*

Q. Are you in partnership with your brother, Mr. H. H. Ayre, cake merchant in Hull?—A. I am.

Q. And have you carried on a large business there as linseed cake merchants for some years?—A. We have.

Q. Do you sell a very large quantity in a year—some 40,000 tons?—We do.

Q. Have you been in the habit of getting cake from Mr. Kidd, the plaintiff?—A. We have.

Q. Is he a seed crusher, carrying on business in Hull?—A. He is.

Q. Under the style of —?—A. Samuel George Kidd.

Q. Have you been in the habit of purchasing from Mr. Kidd a kind of cake known as "Triangle Best"?—A. We have.

Mr. Justice BLACKBURN: I suppose you mean there is a triangle on it as a trade mark?

The WITNESS: That is so, my lord.

Mr. CAVE: Now did you supply "Triangle Best" cake to Mr. Wells?—A. We did.

Q. Did you see the libel which was published in the 'Mark Lane Express'?—A. I did.

Q. That was on the 11th of March?—A. It was.

Q. Can you give me the amount of sales of this cake last year, and this— from March down to July?

Mr. D. SEYMOUR. Has there been a falling off?—A. A very large falling off indeed. I think in round numbers about 1500 tons in the five months.

Mr. CAVE: I think you took the whole of that quantity of cake from Mr. Kidd?—A. I believe we did, with the exception of a very small quantity that Mr. Kidd sent, I think, to his personal friends.

*Cross-examined by Mr. FIELD.*

Q. Do you know that of your own knowledge?

Mr. Justice BLACKBURN: Know what?

Mr. FIELD: That he took all that Mr. Kidd supplied of "Triangle Best" linseed cake.

The WITNESS: I do.

Q. You know it of your own knowledge, do you?—A. I do.

Q. Is this the circular that you communicated to Mr. Wells? (Produces a document).—A. Yes, I believe it was. From this distance I recognise it.

The ASSOCIATE read the circular.

#### △ BEST LINSEED CAKES.

As we are now able to deliver cakes of the above brand, we beg to make you the offer of ten or twenty tons, at 10*l.* per ton, subject to your reply in course of post. The cakes we are now getting are of superior quality, and we think this a good opportunity for buying, as they are decidedly cheap.

Sample No. 723 herewith.

Best New Seed Cottons, 5*l.* 15*s.* per ton.

Superior Old Seed Cottons, 5*l.* 12*s.* 6*d.* per ton.

Waiting your orders,

We are, Yours truly,

AYRE BROTHERS.

Hull, January 19th, 1872.

Mr. FIELD: Now, tell me please. Had you made a special arrangement with Mr. Kidd for the manufacture of this particular cake?—A. Our business transactions—

Q. Had you made a specific arrangement with Mr. Kidd for the manufacture of this particular cake?—A. I don't understand exactly what you mean by a specific arrangement. I may state—

Q. Did you make an agreement with Mr. Kidd (I will put it in these words), as to the materials of which the cake was to be made?—A. We did.

Q. When was that agreement made?—A. I cannot say; but a considerable time back.

Q. I want to know that, because I have no information as to time. When did you make that agreement with Mr. Kidd? Was it in November, or earlier?—A. Earlier considerably. Some years back—I think about four, but I cannot say positively.

Mr. Justice BLACKBURN: It was not in writing, I suppose?—A. Not in writing.

Mr. FIELD: But was that agreement in effect this. The cake was to be made and described as "Triangle Best Linseed Cake," to consist of linseed, sesamé cake, and bran?—A. That was so. The reason of our doing that, my Lord—

Mr. Justice BLACKBURN: Sesamé! It is the first time that I have met with that word out of the 'Arabian Nights.'

Mr. FIELD: Now, did you order from Mr. Kidd, on the 30th of November,

some of that cake so made?—*A.* We did. That is to say, it was a forward contract, one delivery of which was during November. The purchase was 900 tons to be delivered—100 tons in each month,—I think from July to March.

*Q.* Sesamé cake is an article of commerce by itself?—*A.* It is.

*Q.* Where is it imported from?—*A.* France, I believe.

*Q.* Is that a residual product also, or is it manufactured?—*A.* It is the product of the seed.

*Q.* Called Teal?—*A.* Yes, the sesamé. Sesamé we know it by. I believe it is the same as teal.

*Q.* Is it a residual product, or is it a cake made by manufacture?—*A.* It is a residual product after crushing the seed, in the same way as linseed cake is a residual product after expressing or crushing the oil from linseed.

*Q.* Sesamé cake averages a lower price, a good deal, than linseed cake?—*A.* The cake, yes; but if your question applies to the oil and seed, no.

*Q.* I am speaking of the cake. I ask you whether the cake averages a much lower commercial value than the linseed cake?—*A.* It does.

*Q.* And is imported into this country in the shape of cake?—*A.* It is.

*Q.* Not expressed in this country?—*A.* No.

*Q.* But it is saleable in this country at its value?—*A.* It is.

*Q.* You, I suppose, know nothing about this cake. You did not see it at all on its way to Mr. Wells?—*A.* Which cake do you mean?

*Q.* I had better perhaps get the details, as my friend has left it so general. Did you on the 29th of January, or shortly after, send two tons of this cake to Mr. Wells?—*A.* I think we did on the 12th of February.

*Q.* By the railway to Goole, I believe?—*A.* Quite so.

*Q.* Did you see that cake yourself on its way?—*A.* I did not.

*Mr. Justice BLACKBURN:* I suppose you understand the question and answer both to refer to a parcel of two tons?

*Mr. FIELD:* Yes, my lord. (To the witness.) Had you before that time received a letter from Mr. Wells, on the 3rd of February?—*A.* Will you tell me to what purport? I do not recollect the date.

*Q.* I will read it to you in a moment—or rather is this your answer (handing a document to witness)?—*A.* Yes, that is our answer.

The ASSOCIATE read a letter of the 5th February as follows:—

MEMORANDUM.

Hull, February 5th, 1872.

From AYRE BROTHERS to JOHN WELLS, Esq.

24, High Street, Booth Ferry.

DEAR SIR,

Your favour duly to hand. The  $\Delta$  Best Cakes can now be shipped when Fearnley applies for them, and the 5 tons by rail will leave either to-day or to-morrow at latest, we hope. It is unfortunate that this Mill is behind-hand in deliveries owing to a pressure of orders and contracts. We regret the necessity for any delay, but trust you will not be further inconvenienced. We book 2 tons Best Cotton Cakes at 5*l.* 10*s.* per ton, to be sent with the lot by boat. Waiting further favours,

Yours truly,

AYRE BROTHERS.

*Mr. FIELD:* You say in your letter "we are sorry that this Mill is behind-hand in delivery, owing to pressure of contracts."—Were you told that by Mr. Kidd?—*A.* We knew it of our own knowledge—we have contracts with Mr. Kidd.

Q. Will you oblige me by answering my question? Did you know of your own knowledge that the mill was behindhand on account of pressure of orders and deliveries?—A. Yes.

Q. You sent away this cake on the 12th?—A. Yes, I believe that is the date.

Q. On the 17th, did you receive a letter from Mr. Wells of the 16th?—A. I do not recollect the dates.

Q. We have got your answer here. (Production of Mr. Wells's letter objected to by Mr. Seymour, and objection allowed.)

Mr. FIELD: (To Witness). How soon did you say the sale began to fall off?—A. I think about March.

Q. What date in March?—A. I cannot say positively.

Q. This is published on the 11th. How soon in March did it begin to fall off?—A. I cannot say exactly.

Q. Hadn't you a steady sale in April?—A. No. We were pushing it very hard.

Q. Weren't you on the 5th of April selling a great many of the "Triangle Bests"—"the quality of both being much liked at present?"—A. Not a very great quantity, but more than we had been; because we had made an extra strong effort to do so, and the result had been that some orders came in.

Q. Then the sale hadn't fallen off at that time?—A. Yes it had—it was falling off then, and it continued falling off throughout.

Q. Hadn't you a steady sale on the 19th of April?—A. No. It was not so good as it had been.

Q. Is it not the fact that the sales of stock take place in March and April, so that there is always less sale in that month?—A. Yes. But this year compared with the previous year was so very much less.

Q. But the sale does fall off in March?—A. Yes, it does certainly—No! March is generally the best month.

Q. March and April, then? When does the sale stop?—A. Probably about the end of April or May.

Q. Earlier than that?—A. No, March is generally considered the best month we have in the year.

*Re-Examined by Mr. SEYMOUR.*

Q. And can you attribute that falling off to any other cause than that which you have stated, namely the publication of this libel?—A. Certainly not.

Q. You have been asked about the triangle brand. Are there other brands known in commerce?—A. Mr. Kidd makes three qualities of cake.

Q. Two brands—a triangle without any word attached, and Triangle Best?—A. Yes; there is a third quality called the "Diamond K pure." There is a diamond with a K inside it, and the word "pure" attached.

Q. Are the distinctions between these various brands and qualities perfectly well known in the market?—A. Perfectly well known.

Q. There is just one other question which I will ask you, and it is this:—I think you say you have dealt very largely in the particular kind of cake that you supply to Mr. Wells?—A. I have.

Q. With regard to the sesamé that you have spoken of, what is the quality of the oil that is expressed from it?—A. In France it is used for culinary purposes.

Q. For human food?—A. For human food.

Mr. SEYMOUR: That is the case for the Plaintiff.

Mr. FIELD then opened the Defendant's case as follows:—May it please your Lordship, Gentlemen of the Jury. My learned friend has exercised



that right and that discretion which no doubt it is his duty and privilege to exercise in regard to his mode of conducting this case before you; but it is remarkable, rather, that in an action brought to vindicate Mr. Kidd's character, Mr. Kidd should be "conspicuous by his absence" from the box, and that the damages which Mr. Kidd is said to have sustained are proved by Mr. Ayre, who is the Plaintiff in the next action, while Mr. Kidd is kept out of the box altogether. My learned friend will have, I dare say—has I dare say—good reasons for the course which he has taken. It is not for me to speculate upon them, nor do I desire to do so; nor will you be influenced in your judgment upon this case, when you have heard the whole of it, by any considerations affecting the expediency of the mode of conducting a cause which a learned counsel may exercise. It is remarkable, but I am not at all sorry for it, because it enables me to lay before you, at an early period of this trial, the case on behalf of the Council of the Royal Agricultural Society, for whom I have the honour to appear.

Now, my friend has opened the case in an exceedingly temperate speech: he has done that which I fully expected he would do—acquitted the Council (indeed there would not be the smallest foundation for such an idea had he asserted the contrary) of those ordinary motives which sometimes prompt libels, namely, malice or interest in any shape or way. It was impossible for my friend to suggest that the Council residing in London, who know nothing of Mr. Kidd or Mr. Ayre but what their goods and wares themselves inform them, should have been actuated by any indirect motive in doing what they have done. My learned friend did indeed glance at, rather than assert, something about secretaries or chemists, as if he intended to insinuate that the direct malice or indirect motive which he was unable to find in the Body whom he has sued, might reside elsewhere. If he meant that, I know he will say it again more boldly by-and-by. I dare him to do so, or to prove that there is the smallest ground for suggesting anything of the kind.

Now, gentlemen, you have heard a statement which I must supplement, in order that you may know the facts of the case which you will have to decide upon. Mr. Ayre, whom you have seen in the box, is a seller of cake in Hull, and Mr. Kidd is a manufacturer of the same article there; and be it right or wrong with regard to former transactions, it is not for us now to inquire; but for years past—matter of history it is—that complaints have been made, from time to time, of deleterious articles, or articles unfit for food, having been sold under the name and guise of linseed cake; and consequently (as my learned friend opened very fairly to you) the Royal Agricultural Society, who number amongst their members a great many agriculturists, and who take, as their constitution imposes upon them, a warm interest in the fairness of dealing and in the success of everything relating to Agriculture, have adopted a course for the purpose of investigating the qualities of manures, which is a compound article very largely used, and the conformity of which to what it ought to be is a very important matter, and also with regard to the cake, which is still more important in that respect,—they have appointed a committee called the "Chemical Committee," for the purpose of examining into these matters. This Chemical Committee, in the course of their duty, employed an analyst whom you shall see in the box shortly,—Dr. Voelcker, who has for many years examined the various articles both of manure and cake which are sent to him for examination. He has no motive whatever, direct or indirect, of malice or otherwise, against Mr. Kidd or Mr. Ayre, or any person connected with them. But he is in the habit of receiving from persons, either members or non-members of the Society, any articles of food or manure which they are desirous of submitting to him for analysis, and he examines them and makes his report upon them.

Now, gentlemen, before I come to the Report, let me tell you—what I am

prepared to prove—as to what had occurred with reference to this very cake ; because I think my learned friend might have done very well to have said a few words about that. He knows by the Report what the charge made against him is, and certainly I did anticipate that he would have gone into this matter or given you some explanation about it, but he leaves you in utter and absolute ignorance with regard to what had occurred, and for aught that his case has disclosed to you, this article of the 11th March might be the most gratuitous libel that ever man penned. Indeed, that is the reason, of course, why my friend leaves it in that shape ; but the facts of the case were really these : It is quite true Mr. Ayre had made a contract with Mr. Wells, who is a gentleman living in Yorkshire, and a member of the Agricultural Society. He farms very largely, and has done so for a great number of years. He has three farms in Yorkshire, two of which you will find to be of considerable importance with reference to the inquiry you have in hand. One of them is a farm called Booth Ferry, near Goole, consisting of some 600 acres ; the other is called Airmyn Pastures, some two or three miles from Booth Ferry, and which is a farm of about 400 acres. Mr. Wells himself resides at Booth Ferry, but both Booth Ferry and the Airmyn Pastures Farm are under his superintendence, he having people under him at Booth Ferry to manage there the feeding and care of the stock, and having a bailiff at Airmyn Pastures to do the same there. Mr. Wells—I do not want to praise him to you—but he is a gentleman of considerable reputation as an agriculturist ; he has a very excellent breed of pure Shorthorns, and he takes very great pains indeed in managing them. I mention these things, in order to show the care which is likely to be exercised in the management and feeding of his cattle. The course of dealing with them is this :—The beasts are taken up some time in the month of September ; they are then stall-fed and fattened, according as to whether they are for show or sale, or whether they are cows, and so on. They are fed on until the month of March, when they are sold. This course he has continued for a great many years, and he has fed the beasts with cake precisely in the same manner as he fed them with cake on the 15th of February, without, I believe he will tell you, any accident ever occurring at any previous period of time. The mode of feeding adopted is one well calculated to promote the health of the beasts. It is one with which it will be impossible for my friends to find any fault at all, and I am prepared to prove, if a question is made about it, that it is a judicious mode, and one in which it is impossible to look for, or account for, what happened on the 16th February. On the 12th February as you have it now in evidence, two tons of this cake, which, as you heard from Mr. Ayre, had been late in delivery because Mr. Kidd's mill appears to have been under great pressure—I suppose they were in a great hurry to get rid of their goods—two tons of this cake were, under this pressure, supplied to Mr. Wells, one ton of which was taken to the Booth Ferry Farm, and the other ton to the Airmyn Pastures Farm, three miles off. The Booth Ferry Farm was under the superintendence of one class of persons, the Airmyn Pastures under the superintendence of another. There were 26 beasts at that time at Booth Ferry, being fed for the purposes of sale and show in the following season, and the mode of feeding adopted was this :—The days were short February days ; the beast had his feed of turnips or potatoes, he was cleaned, and then at Booth Ferry he had in the afternoon, about half-past one or two, just immediately after dinner, 7 lbs. of cake. At Airmyn Pastures, where they had a different sort of stock, the mode of feeding was different, for there the animals had their cake in the early morning, about 8 o'clock. They first had chopped hay and clover, and then they had their cake ; after which they had another dose of potatoes or mangolds, or something of that sort, and then no more cake that day. That course had been adopted for years as the mode of feeding at Booth Ferry as well as Airmyn Pastures.

The stock was purchased some time in the month of September; it was taken from grass, and at Booth Ferry the beasts were put immediately on their 7 lbs. of cake. No injury whatever followed. They ate their 7 lbs. of cake daily down to the month of February, when the supply ran short. But I should tell you, further, that at Booth Ferry there were not only feeding stock, but also cows, and the cows had a pound less of cake. I am told that the quantity supplied at Airmyn Pastures was usually as great as that supplied at Booth Ferry; but at the time in question, when this cake was supplied, they had less than the usual quantity; and that there the cake was something like 4½ lbs. instead of 7 lbs., which was the quantity supplied at Booth Ferry.

Now that being the state of things some time in the month of January Mr. Wells received from Mr. Ayre a Circular which has been read to you in which Mr. Ayre offered him "Triangle best linseed cake." Before that time he had had cake which had been obtained from Driffield, where I believe they make only one sort of cake, and the beasts had eaten that cake with perfect impunity the whole time.

Well, gentlemen, the cake arrived, one ton at Booth Ferry and one ton at Airmyn Pastures, and there is no pretence whatever for saying that anything had happened to the cake at all in the transit from Hull, or after it had been delivered. After the arrival of the cake, on the 16th, Mr. Wells left home in the morning, he came home again in the evening, and to his surprise, and horror, one might almost say, he found that immediately after the cake had been given to the beasts they fell, all of them, immediately ill. One cow he found was dead: he found the other cows, a bull, heifers, and steers, all distended, and the rest of the stock all moaning and in a state of great distress. The cow that was lost was a valuable Shorthorn. All the cattle had been in perfect health that morning. I shall call before you the people who gave them their food, and they will tell you that in less than half an hour after the cake was given to the beasts this thing occurred. You know the symptoms of illness: they were violently purged, their dung was black and offensive, and in the course of the afternoon, notwithstanding the greatest efforts made by administering oil to the poor beasts, one of them died, and the rest had a very narrow escape of their lives, and continued ill for several days. That is what occurred at Booth Ferry.

At Airmyn Pastures that morning the cake had been given to the stock and exactly the same results followed, except that the quantity given being rather less, although the stock was all ill, and suffered the whole of that day, not one of them died; but they all recovered. Now you know, gentlemen, that was immediately after the administration of this food to them, and without the smallest predisposing cause. Of course I do not know what my friend is going to suggest. If he is going to suggest that this was caused by anything else than the administration of this cake, he will do so. Otherwise, if it was caused by the administration of this cake, what other result can you come to but that it was an unwholesome cake, a cake not fit for food, and containing unquestionably either by reason of its mode of manufacture or by reason of its composition, things calculated to produce such results.

Great complaint has been made of the course pursued; but now let us see what Mr. Wells did. My friend will not allow me to give in evidence the course that he adopted with regard to Mr. Ayre although I proposed to read to you a letter of the 16th of February written by him to Mr. Ayre, that being the very day in fact that this thing happened. My learned friend objected, and successfully in point of Law, to your hearing that letter read. Whether it was a thing which should have been kept out is another matter—we shall hear by the cross examination; and probably before the cause is over, that letter will come out. But still the next thing he did (I cannot put to you the reasons why) was to send a letter with an account of this to the Agricultural Society.

On the very same night that he wrote that letter he also forwarded to Dr. Voelcker, the Chemist, a sample of the cake; Dr. Voelcker made his analysis, and that analysis he furnished to Mr. Wells. Mr. Wells then went up, I think himself, to London, and was there and laid the case before the Council. And now I will read to you what it is that thereupon the Council have written and said with regard to this matter. It is the Report of the Chemical Committee, not the Council itself. They made their examination and they said this—(the learned Council here read the Report in question.)

Now, gentlemen, that is the whole of the libel in this case. The Plaintiff in his declaration, and his counsel at the bar, say that we charge by this libel that the cake contains poisonous materials and poison; but I think with reference to that you will be of opinion that it does not fairly bear that construction. So far from making that assertion, the Report itself speaks of this being a case of “so-called” poisoning; and with regard to Mr. Wells’ case, it states what are the elements of the cake, and what we charge against that cake is that it very much “resembled” the cake supplied to Mr. Eaton; it does not say that it has the same qualities. And then it goes on to charge against it that it contains a variety of seeds,—“cotton-cake, rice, broken corn, and cocoa-nut, apparently made from dirty linseed, and the sweepings of corn warehouses.”

Now I shall prove to you what you have already heard from me with regard to the case of Mr. Wells, that the whole of his cattle were seized with serious symptoms immediately after eating of this cake. I shall also call before you Dr. Voelcker, and other gentlemen of skill and science, who will tell you that the cake does contain these things which are here mentioned, and will give you their judgments upon it. I cannot help thinking that if my learned friend had thought it right to put Mr. Kidd into the box, and the people in his employment, before it became my duty to call these gentlemen, it might have assisted the inquiry a great deal, because we should then have had the advantage of knowing what it is that Mr. Kidd says was put into the cake. You see my friend has notice of what we charge as being the contents of the cake. He has Mr. Kidd and those who are employed in his mill here, who would have proved what the cake is made of, and you would have been in a better position if you could have heard their evidence, together with the evidence that I am about to lay before you. But, as I said before, my friend is master of his own case, and he thinks it more wise and prudent to keep Mr. Kidd out of the box, and prevent my getting the information from him which I might have had upon that inquiry. This much you know we have been able to extract, because we had a letter of Mr. Kidd’s in our own possession, and we have obtained from Mr. Ayre the same information, that this is cake made expressly for Mr. Ayre by agreement with him, and that it does contain sesamé cake and bran, as well as linseed. Whether or not a cake consisting of sesamé cake, linseed, and bran is a “best linseed cake” is a matter we may have to try in another cause; but there is one thing I ought to explain with reference to sesamé. Sesamé is a cake in itself, and we shall learn, if we have any person who comes into the box to give us any information about it,—we shall certainly seek to inquire,—what is the process connected with that sesamé cake. I believe it will turn out that the sesamé cake is in itself a commercial article, and that it is broken up and crushed together with linseed cake to make the cake in question. My friend, in opening his case, said that linseed cake was what everybody understands it to be, the residual product of linseed after it is crushed for the purpose of expressing the oil from it. That is, you know, the linseed which comes either from Calcutta or the Black Sea. Now there is, no doubt, in all linseed a certain admixture of seeds, either put into it abroad or growing with the linseed, and as my friend ingeniously says, no doubt there are various brands, one of them

“pure linseed” and another “best linseed,” but both of them are “linseed cakes,” and as my friend says they are, or should be, the result of the pressure of the seed. How therefore sesamé and bran can be properly united with the linseed in making what is called “linseed cake” I do not know. But I think it exceedingly probable that you will find, if my friend goes into that matter, that sesamé cake not being saleable in itself has been broken up, and being in a condition to do mischief if taken by itself, may also be the cause of injury when mixed up with linseed. But, gentlemen, be that as it may, I shall prove to you by the effects of this cake upon the cattle that it was an unwholesome cake, and one which produced results known as blood-poisoning, beyond all question. One of the cattle died, you know, and the rest of the stock were made seriously ill.

Well, that being so, my learned friend complains of the Agricultural Society that they published their Report without communicating with Messrs. Kidd. Gentlemen, the course that they adopted there is one which is adopted in all cases. The description given in this Report they received from their chemist and analyst, and I will prove it to be correct. Then under those circumstances it is part of their ordinary duty, and part of their ordinary arrangement, in order that the public may know what cakes there are which are genuine food, and where they are to be obtained, and to publish the names of the makers and sellers. But that Mr. Kidd has sustained any great injury from this particular publication I do not think is at all apparent, because immediately afterwards they offer Mr. Kidd at once that he should have an independent person who should make an analysis of the cake, and they offer immediately to publish that analysis, whatever it may be. Gentlemen, I am not going to weary you with the letters or the long criticisms which Messrs. Roberts and Leak thought it right to administer. My friend says he makes two complaints. I am willing to meet him upon every head of complaint, and I deal with the first in the way I have done already. With regard to the second, it is that we refused to send him a sample of the cake, in order that he might make an analysis for himself. Gentlemen, what we did do was this,—we offered him that which I hold to be the fairest thing that persons could offer when they are going before a jury on the respective analyses or ingredients of any article, whatever it may be—we said to him, “You shall appoint your own independent chemist, who shall make his own independent analysis; Dr. Voelcker will be present, and they may make a joint analysis,” but it is utterly incorrect to infer that we ever asked or supposed so absurd and unjust a thing as that he was to be bound by the analysis of Dr. Voelcker, or anybody else. I say the fairest thing that could be done is this; when a man asks for an inquiry of this sort, let the two analysts meet and make a joint analysis, and appoint an independent person for that purpose. That course was offered by us, and they declined to accede to it, and in those circumstances I think we were perfectly justified in not sending them a sample when we should not have the means of knowing what the experiments to be made upon it were; because nothing is so fallacious as experiments made by parties to a cause after a dispute has arisen, and when the litigation is active, for the purpose of supporting their own views of their own case. Unfortunately, you know, scientific men, and all men who go into examinations of that description, go into them with a bias beforehand, and therefore I also further say that if experiments have been made at all upon cake of this description by anybody, they have been made behind our backs, and no notice has been given to us of anything of the kind.

Gentlemen, with this plain statement of the facts I leave the case for the present, knowing that I shall have the honour of addressing you again by-and-by, when I shall know more about my friend's case than he has thought

it right to tell us at present. I shall therefore reserve my general observations until then. I have led your minds to the facts, which I am prepared to prove, and after I have called my witnesses, whether my friend calls any further evidence or not, I shall have an opportunity of addressing you again before the case closes.

Mr. JOHN WELLS sworn: *examined by Mr. MELLOR.*

Q. Do you live at Booth Ferry House?—A. I do.

Q. I think you are a magistrate for this division, and a member of the Royal Agricultural Society?—A. Yes.

Q. You are also a landowner in the Riding?—A. Yes.

Q. Have you two farms—one at Booth Ferry?—A. Yes; about 600 acres.

Q. And another at Airmyn Pastures?—A. Yes, 400 acres.

Q. How far is that from Booth Ferry?—A. The farmhouses are about three miles apart.

Q. I think you have also another farm called Sancton?—A. I have.

Q. At Booth Ferry and Airmyn Pastures had you feeding beasts?—A. I had.

Q. What number at Booth Ferry?—A. I think there would be twenty-four feeding beasts—two bulls that were feeding, and there were two or three holding heifers—in-calving heifers—besides, but they were not fed.

Q. That was in February last?—A. In February last.

Q. Were they of any particular breed?—A. Shorthorns—they were generally the common Shorthorns.

Q. But there were several cows besides?—A. There were eight cows; three young bulls and two young heifers as well as the feeding beasts, likewise getting cake.

Q. Were they of the same breed as the others?—A. They were a pure Shorthorn breed stock entered in the Herd Book.

Mr. Justice BLACKBURN: Now just let me understand if I have got them right—you had twenty-four beasts and two bulls feeding, and also eight cows, three young bulls, and two yearling heifers which were not feeding, but which got cake; and also two or three in-calving heifers not feeding?—A. Yes.

Q. Did they get cake?—A. They got a little cake.

Mr. MELLOR: Now at Airmyn Pastures how many feeding beasts had you?—A. I think there would be twenty-two feeding beasts there.

Q. Where there any others that had cake besides the twenty-two?—A. No. There were some animals that had not cake that morning—they did not get cake.

Q. What breed were the twenty-two?—A. They were similar—what we call the Shorthorn breed. They were animals purchased for feeding; three steers and two or three drapes. They were all feeding animals.

Q. What is your system with regard to feeding with cake at Booth Ferry?—A. They generally give them about seven pounds of cake a day each. At least, that is the quantity I expect them to get. I do not see them fed.

Q. What time of the year do you begin to feed with cake?—A. As soon as ever we put the beasts up.

Q. When is that—the first week in October?—A. It varies; sometimes it is a little later in October; last year it was about the first week in October.

Q. Up to February, in the present year, had the beasts been fed with cake, both at the Booth Ferry and Airmyn Pastures from the time they were taken up?—A. Yes, they had.

Q. How had they done on the cake they had?—They had been exceedingly well; and they are as healthy a lot of beasts as any man ever saw.

Q. In the beginning of February were you out of cake at both farms?—A. Yes, we were.

Q. And did you receive the circular that has been put in from Messrs. Ayre Brothers?—A. I received a sample of cake, with a small memorandum inside, offering me cake in the latter end of January.

Q. Was this sent to you (handing a circular to the witness)?—A. I might receive something like that—very likely I should. I have no doubt such a thing would come, but it was not in reference to the sample of cake which I had. They sent me a circular every week.

Q. I believe you have mislaid the letter?—A. I have mislaid the letter. I wrote to that effect to Messrs. Ayre.

Q. Did you order some cake of Ayre Brothers, and were two tons of cake sent to Goole Station in consequence of that; and did you send for them on the 15th February?—A. I made a contract in my letter for a quantity of cake, and two tons of that cake were sent by rail to Goole.

Q. Did you send two waggons to Goole station?—A. Yes, on the 14th, one from Booth Ferry, and on the 15th one from Airmyn Pastures.

Mr. SEYMOUR: I think it is admitted.

Mr. Justice BLACKBURN: Mr. Ayre says two tons were sent there, and therefore it is probable they were the same.

Mr. MELLOR: You sent one wagon to take it to Booth Ferry, and the other to take it to Airmyn Pastures?—A. Yes; but on two separate days—the one on the 14th and the other on the 15th.

Mr. Justice BLACKBURN: Did they bring equal quantities to each—a ton to each?—A. As near as they could tell. I think the man says the cakes were counted; but they got it as near as they could.

Mr. MELLOR: On the morning of the 16th of February did you go from home?—A. I did.

Q. What time did you get back to Booth Ferry?—A. Half-past five—a few minutes later perhaps.

Q. Did you then go to see the feeding beasts?—A. I went immediately round the stock.

Q. What state of things did you find there?—A. I first went into the cow-house and I saw a cow laid dead, two or three others very much distended, but a red cow and a white cow in particular; and the other five (there were eight in the cow-house) seemed to be suffering very much. I went from there to see the young bulls, and found a young roan bull, a year and a half old, suffering very much indeed, and very much distended. The other two not so much so, but still showing symptoms of being uneasy. The feeding stock are in a different portion of the farmstead. I went round them. I found two white steers and a red steer blown up and distended fearfully; a four-year-old roan heifer suffering very severely, but not so much distended; all the other animals more or less affected. Some of them were shivering in their limbs; some of them had their tongues hanging out. I ordered the man who had brought me with the dog-cart to go immediately for the veterinary surgeon, Mr. Midgley, of Goole, and also to request John Hutchinson, who is a butcher and cow-doctor, to come from the village.

Q. Did you wait till Mr. Midgley came?—A. We commenced getting some of the beasts out.

Q. Did you examine the feeding troughs?—A. No, I did not, personally, I subsequently requested that all the troughs should be examined, and any portions of the cake that might be in them to be taken out.

Q. Do you know what quantity of cake was found unconsumed in the troughs?—A. Well, from the appearance of the bag—it was not weighed—I should say perhaps four stone. It was put in a guano bag.

Mr. SEYMOUR: Four stones left unconsumed?—A. I did not see it weighed, but according to the best of my judgment.

Mr. MELLOR: What steps did you take that night?—*A.* I left it with the veterinary surgeon. I immediately wrote to Messrs. Ayre. I had just time before the post went out, which leaves at 7 o'clock, and I wrote to Dr. Voelcker and requested one of my clerks to get a portion of cake put into a bag and sent up to Dr. Voelcker.

*Q.* Out of what you talk of as being found in the troughs or from the bulk?—*A.* Out of the bulk that had been broken up. I ought to add that I requested a junior clerk to go immediately to Airmyn Pastures to tell my man there not to use the cake as our animals were all wrong.

*Q.* With regard to the cake that you told the clerk to get—did he get some of the cake?—*A.* Yes, he got some of the cake and that was put into a bag and sent by rail to Dr. Voelcker, and the letter by post.

*Q.* Did you send it that night?—*A.* I sent it that night.

*Q.* The next day did you go to Airmyn Pastures?—*A.* Yes.

*Q.* Before we leave the night of the 16th, did anything further occur to the cattle?—*A.* We had them out in the grassfield, the worst of them until late and when they began to settle we put them up again.

*Q.* Did you give them anything that night?—*A.* I left them in the hands of the veterinary surgeon entirely.

*Q.* Next day when you got to Airmyn Pastures, what state of things did you find there?—*A.* The first thing in the morning I sent a telegram to Messrs. Ayre to say that the remainder of the cattle were out of danger.

*Q.* What state of things did you find at Airmyn Pastures when you got there?—*A.* I found the cattle there were staring in their coats, but perfectly easy the next day.

*Q.* Did you receive any complaint from your men there with regard to the cake?—*A.* Yes.

*Q.* Did you notice at either places the dung?—*A.* Yes, I did at Booth Ferry—that is the next day—the 17th. It was very black and very offensive. I may say the heifer continued in a bad state for several days—the roan heifer that I alluded to in particular.

*Q.* How long was it before the cattle recovered at Booth Ferry?—*A.* Some of them took their food again next day—a good many of them; three or four that I have mentioned looked very bad for a few days.

*Q.* When were the beasts next fed with cake after this?—*A.* I ordered that no more cake was to be given to them until I got some fresh.

*Q.* When did you get some fresh cake?—*A.* Six or seven days after; I wrote immediately for more cake but it would be that time before I got it.

*Q.* How did they do upon it as far as you know?—*A.* Very well indeed—no illness, no trouble of any sort.

*Q.* The 17th of February you wrote to Dr. Voelcker?—*A.* Yes.

*Q.* How long afterwards was it before you communicated with the Secretary?—*A.* I communicated almost immediately with the Secretary. I think I was asking for information—something about sending the animals, but there will be a correspondence there.

*Q.* After communicating with the Secretary, did you send him a cake?—*A.* I did.

*Q.* Did you send to him more than once?—*A.* I sent him some twice.

*Q.* Where were the cakes taken from?—*A.* The first cake that I sent him was from Airmyn Pastures.

Mr. Justice BLACKBURN: The cake that you sent him from Airmyn Pastures, was it or not one taken out from the bulk that had been brought from Goole?—*A.* It was taken from the bulk that was brought from Goole.

Mr. MELLOR: Had you given directions that all the cake in question should be kept separate and apart?—*A.* Yes.

*Q.* Where did you take the second sample from?—*A.* From Sancton.



Q. What was the first sample you sent to Dr. Voelcker?—A. That was broken cake from Booth Ferry.

Q. And the second sample was from Airmyn Pastures?—A. Yes.

Q. That went to the Secretary of the Society?—A. Yes.

*Cross-examined by Mr. SEYMOUR.*

Q. There were 15 tons of cake ordered?—A. There were.

Q. Of those two went to Booth Ferry?—A. To Booth Ferry.

Q. And five to Sancton?—A. Five to Sancton.

Q. And were used at Sancton?—A. And were used there?

Mr. JUSTICE BLACKBURN: At what date did the five go to Sancton?

Mr. SEYMOUR: The same date.

The WITNESS: No, considerably earlier.

Q. The 6th of February?—A. Yes.

Q. And as you say were used there?—A. And were used there.

Q. And you have no complaint to make with regard to the cattle there?—A. Nothing with regard to the cattle there.

Q. Before we come back to Booth Ferry there is one question which has occurred to me to ask you about Airmyn Pastures—did your milch cows at Airmyn Pastures get cake?—A. I believe not.

Q. What were you feeding your cows upon (it was a cow that died and so I give prominence to the cows) at Booth Ferry—did you use any mangolds?—A. Yes, we used mangolds for the cows—they were the only animals that got mangolds.

Q. How long had you used mangolds?—A. For several weeks.

Q. Do you know how many—several might be two or three or twenty?—

A. We give the cows mangolds, because it does not make the milk taste.

Q. It improves the supply of milk?—A. It does not make the milk taste.

Q. It improves the flavour?—A. Yes, of the butter and the milk.

Q. You have got one of your men coming here?—A. Yes.

Q. Can you state of your own knowledge how long the cow had or had not been taking mangolds or what proportions she had been feeding upon—if you do not know of your own knowledge, I had rather you would not speak because it may be material in this case?—A. Well, I will not say because I do not see them fed.

Mr. FIELD: We shall call the men.

Mr. SEYMOUR: Very well. (To the witness) You had a letter on the 25th March from the Secretary of the Agricultural Society?—A. Yes, and replied to.

[The letters put in and read.]

Q. Now you sent up, if I understand you, samples of the cake that was used at Sancton?—A. I sent one cake up.

Q. Can you tell me—aye or no—has that cake been analysed?—A. I believe it has, but I do not know the result.

Q. You do not know the result?—A. No, I do not.

Q. Then perhaps my friend will excuse me if I ask whether I can have the result of that analysis?

Mr. FIELD: I can give you no answer upon that.

Mr. SEYMOUR: Then you do not know the result, and my friend is silent?—A. No, I do not.

Q. You sent up the cake?—A. Yes.

Q. Now I will go to the two tons that went to the Booth Ferry. Did you keep a portion of that besides what you sent up for analysis?—A. Oh, yes; I kept the whole of it.

Q. Did you also keep the sample?—A. I did.

Q. Were you applied to by Messrs. Ayre and by Mr. Kidd for a portion of the sample?—A. No, I never was applied to for a sample of the cakes.

[Correspondence between Mr. Wells and Mr. Ayre objected to by Mr. Field, on the same ground as Mr. Seymour's previous objection to Mr. Wells'.]

Mr. SEYMOUR: You did send up a portion of the two tons?—A. I did from each place.

Q. They were sent in a bag?—A. They were sent in a bag from Booth Ferry, broken.

Q. What sort of bag?—A. A little thin bag. The men will speak to it.

[The Bag was produced.]

Q. It is what we call a guano bag?—A. Yes.

Q. How did the two tons of cake come to your place?—A. My foreman sent a waggon for it.

Q. Where to?—A. To the Railway Station.

Q. At that station where it came from, are there chemicals and other matters of commerce stored?—A. I am sure I cannot say, every thing generally comes to Railway Stations.

Q. Have you any chemical manures at Booth Ferry?—A. Yes, we have, for our farming purposes, but they are stored always in a house.

Q. Where was the cake stored?—A. In what we call the chop chamber, close by the cake-breaker—a machine for breaking cake.

Q. What about the clover?—A. Nothing about the clover. There was no clover.

Q. I thought you said it was where they chopped the clover?—A. It is in the house where they chop the clover in the winter time.

Q. Is it put upon the same floor where the clover is chopped?—A. The same floor.

Mr. SEYMOUR: Were your cattle being fed with clover as well as mangolds?—A. No, they were fed with straw.—Oh! the cows were fed with clover.

Q. Had they besides clover and mangolds any potatoes or turnips?—No, the cows had not, the fed beasts had.

Mr. Justice BLACKBURN: I suppose all this is material?

Mr. SEYMOUR: It is.

The WITNESS: My Lord, I am not speaking of my own knowledge; the feeders will come and tell you everything, but this is what I understand was done.

Mr. Justice BLACKBURN: I dare say it will be generally quite accurate; if you make a mistake it will be corrected. You say the cows had clover?—A. They would have hay or clover.

Mr. SEYMOUR: My question is whether the milch cows were not fed with clover as well as mangolds?—Yes, clover or hay. I cannot say which.

Q. And the fattening beasts, were they fed with potatoes and turnips?—A. Potatoes and turnips, at Booth Ferry.

Q. I am asking about Booth Ferry; but when you say that do you mean to distinguish it from Sancton?—A. I want to distinguish it, from Airmyr Pastures—each farm by itself.

Q. You were without linseed cake, if I understand you, at Booth Ferry, for a fortnight?—A. I should think we should be.

Q. Would it be a little more than a fortnight?—A. No, I think that would be the outside.

Q. Then this cow that died during that time, her particular food would be mangold and clover?—A. She would have just the same quantity of mangold—at least, I suppose so. Really these questions should be answered by the man, for I was not there to see it.

Q. Do you know what quantity of linseed cake she had been feeding on?—A. No; the man will answer all these questions, because I never saw the animals fed.

Q. Then you leave it to him?—A. It is left to him.

Q. Did you give him any special caution?—A. I did not.

Q. Here is a cow, a fortnight without artificial cake, feeding on mangold and clover, and you leave it to his discretion without any caution?—A. I said nothing at all about it. The cows, I believe, were not quite so long without cake as the steers—at least, the man will tell you that.

Q. The symptoms that you saw were distension?—A. Yes.

Q. Shivering?—Yes.

Q. And distress?—A. And distress—moaning.

Q. You have added that uneasiness, distension, shivering and distress, moaning, and general uneasiness?—A. Yes.

Q. And we have heard also the description of the appearance of the dung?—Yes.

Q. Are there any other symptoms that occur to you to mention—striking you as a farmer?—A. No, I do not know of anything else; for two or three days they were like other beasts, with staring coats very much, and showing that they had been wrong.

Q. Well, I suppose when cattle are out of order they show staring coats?—A. Yes.

Q. You have been asked about a form that you received from Messrs. Ayre—you did receive circulars from them?—A. A circular comes, I think, every week.

Q. Is this the sort of circular (handing one to the witness)?—Yes, that will be the style of circular.

Mr. SEYMOUR: Do you object to my stating the effect of it?

Mr. FIELD: Of course I do. You kept out what I wanted to get from Mr. Ayre.

*Re-examined by Mr. FIELD.*

Q. You say you left it to the discretion of your feeder with regard to the feeding of the cattle; how many years has he been with you as feeder?—A. With myself and my uncle nearly forty years, the feeder of the cows thirteen years—that is, at Booth Ferry.

Q. At Airmyn Pastures?—The man has been with me thirty years and the foreman twenty-six.

Q. That is Calvert?—A. Yes.

Q. Now, with regard to Sancton, do you know the course of feeding personally at Sancton?—A. No, I do not; I am very seldom there.

Q. You would rather leave that to Mr. Dean?—A. Yes; I am very seldom there.

Q. You say the shepherd complained with reference to the sheep?—A. Yes, he complained very much.

Mr. SEYMOUR: The sheep rejected it for a time, that is your expression?—A. Yes.

GEORGE TUTTY sworn: *examined by Mr. FIELD.*

Q. Are you a farm labourer?—Yes.

Q. How many years have you been in Mr. Wells' employment: with him and his uncle?—A. Forty-five.

Q. Has it been your duty to look after the cattle and their feeding?—Yes, for thirty-six years—thirty-six winters.

Q. At what time of the year do you usually commence to put the cattle up?—A. About October.

Q. What has been your course of feeding at Booth Ferry for the feeding beasts?—This present winter?

Q. No, as a rule?—A. Well, in the morning I tell you how I start with

them. I begin to clean them out, and I give them straw, and after that I feed them with Swede turnips—cut turnips in the beginning of winter, that is what they get in the forenoon; straw and turnips or else potatoes, whichever we are using, sometimes we have potatoes, not always turnips.

Q. What do you do next?—A. Then in the afternoon, about two o'clock, I feed them with cake.

Q. And then after the cake what do you give them?—A. I feed them with turnips again.

Q. How soon after you have given them cake do you give them their feed of turnips?—A. About an hour or so; when I get round them.

Q. What quantity of cake has it been your practice to give to the beasts?—A. About 7 lbs.

Q. You have not charge of the cows have you?—A. No.

Q. Spivey has charge of the cows?—Yes.

Q. What number of beasts had you on the 16th February?—A. Twenty-five feeding beasts, and thirty altogether; the others were heifers and bulls.

Q. How many heifers had you?—A. Feeding?

Q. Feeding.—A. We had nineteen bullocks.

Q. How many heifers had you—you had twenty-five feeding beasts, and besides that what other feeding animals had you?—A. Four heifers and a bull, that made thirty; that was my quantity.

Q. Were they feeding?—A. No, they were not feeding.

Q. Had you any more feeding beasts besides the twenty-five?—A. No.

Mr. Justice BLACKBURN: I do not know when they talk about feeding beasts, whether it means exclusively oxen, or whether there might not be a cow.—A. There were nineteen bullocks,

Mr. FIELD: And six heifers?—A. Yes.

Q. Out of the twenty-five?—A. Yes.

Q. And what had you besides those?—A. I had four heifers and the bull that I had to manage.

Q. Did those have cake?—A. Yes, but not quite so much.

Q. What quantity of cake had they?—A. About half the quantity the others had.

Q. Do you recollect the ton of cake coming in?—A. Yes.

Q. Did you see it come in?—A. I helped to get it in.

Q. Did you see where it was deposited?—A. Yes.

Mr. Justice BLACKBURN: When you say that, do you mean you took it from the cart?—A. Into the chamber out of the waggon.

Mr. FIELD: Did you see it broken up?—A. Yes, I broke it up.

Q. When?—A. By the steam-engine.

Q. When?—A. It was on the 16th, I believe—on the Friday.

Q. That morning?—A. It was after dinner that I broke it up.

Q. On the same day that it came in?—A. No, there was a day between.

Q. Did anything get mixed with it?—No, it could not.

Mr. Justice BLACKBURN: Was it all broken up?—A. Yes, I broke it all up; I thought there was only a small quantity so I broke it up.

Mr. FIELD: Was anything mixed with it on your master's premises?—A. Oh, no; it could not be: it was in a place to itself.

Q. Now, the same afternoon that you broke it up, did you give it to the cattle?—A. Yes.

Q. How much did you give to them?—A. About 7 lbs.

Q. To the twenty-five?—A. We allow them about 7 lbs. always.

Q. To the others?—A. About 3½ or 3 lbs.

Q. How long after you had given them their cake did you notice that there was anything amiss with them?—A. It would be about three-quarters of an hour, or perhaps an hour.

Q. Tell us, in your own way, what it was you saw?—A. Well, I started to feed them again after that.

Q. With potatoes?—A. With potatoes, and I had got half a dozen of them fed (they stand three together); and the next that I came to was blown up like a bladder fit to burst.

Mr. Justice BLACKBURN: Did you say you had fed two lots of three—six beasts?—A. Yes.

Mr. FIELD: Go on; tell us what you saw?—A. The next beast, the eighth beast, was not so much blown up, but he was standing shivering and shaking, as if he was going to die, and I could not tell what was amiss with him. I got them some oil—some fish-oil—and gave it them; and I was stood with my hand in the mouth of that one that was blown up so bad, making him stir his tongue, so that he would break wind.

Q. You gave them fish-oil?—A. Yes, we always do when there is anything amiss with them.

Q. You tried to make him chew his cud?—A. Yes.

Q. You put your hand into the mouth?—Q. Yes, right into the mouth.

Q. What happened to the other beasts: give me the general condition of them?—A. I was with them awhile, and afterwards I began to examine the others, and there were three or four more of them blown up; and there was not one beast but what was affected; those that were not blown up stood as if they were starved, with their backs up, and the flesh of the thighs of some of them shaking and shivering upon their thighs.

Q. How were they affected otherwise? I do not want to lead you on, but were they moaning and distressed?—A. Yes, in pain.

Q. That continued, I believe, till Mr. Wells came home in the evening?—A. Yes.

Q. They took several days to recover, I believe?—A. Yes.

Q. It was not one of yours that died; it was one of Spivey's that died?—A. It was one of Spivey's.

Q. Now I want to ask you, were they purged a good deal?—A. Yes.

Q. How long did the purging continue?—A. I could not exactly say that to a day or two; they were very bad, and the dung was quite black.

Q. In the evening of the first day did you clear out what was left in their troughs?—A. Yes.

Q. How much came away?—A. About three-quarters of a guano-bag full.

Q. How much does the guano-bag hold?—A. About eight stones.

Q. About six stones, then, it would be?—A. We did not weigh it, not then.

Q. Was there anything in the course of feeding, as far as you can judge, that accounted for what happened to these cattle, then?—A. No; no difference in feeding, not a bit of difference in feeding.

Q. Can you tell me how long it was before that time that your beasts had not had cake?—A. About ten days.

Q. When these beasts came in, had they ever had cake before?—A. Before we tied them up?

Q. Yes.—A. I do not know, I am sure, about that.

Q. Had they been a long time, at all events, without cake; did they come from grass?—A. Yes, they came from grass, but then we had had them tied up, you understand.

Q. They would be a long time without cake, then?—A. Yes, very like they never would have had any.

Q. At that time you gave them 7 lbs. of cake?—A. Yes.

Q. After this had happened Mr. Wells gave you orders not to give them any more of Mr. Ayre's cake?—A. Yes.

Q. And did you give them any more?—A. No.

Q. How long were they without cake after that—before they had any fresh cake?—A. Not above five or six days. I cannot say exactly.

Q. And then did they have fresh cake?—A. Yes.

Q. Did that affect them at all?—A. Not a bit.

Q. Have they been without cake at any time since?—A. No.

Q. Was any clover given to the feeding beasts?—A. No, never; neither hay nor clover.

Q. Nor mangold?—A. No.

*Cross-examined by Mr. SEYMOUR.*

Q. You gave them, I understand, turnips and potatoes?—A. Yes.

Q. And straw?—A. Yes.

Q. You say they had had cake previously?—A. Yes.

Q. They had been taken from grass at that time?—A. When we first tied them up they had.

Q. And then you fed them in stalls with potatoes and turnips and cake?—A. Yes.

Q. How were the potatoes given them—boiled or raw?—A. Raw.

Q. What quantity of cake were they taking before your cake failed; while you had a supply, before the order came from Messrs. Ayre, what quantity were they getting?—A. About 7 lbs.; that is what we allow them.

Q. Quite so. I want distinctly to understand you. Each beast was having about 7 lbs. per day of cake as long as you had cake?—A. Yes.

Q. Then, your supply of cake was off for ten days?—A. Yes.

Q. And then you began with 7 lbs. again?—A. Yes.

Q. What sort of cake was it you had previously given them; was it Driffield cake?—A. I believe it was Hull cake, but I do not know whose; I never inquire so much where it comes from; but I believe it was Hull cake that we got after.

Q. You have told us you had 25 feeding beasts: 19 bullocks, and 6 heifers?—A. Yes.

Q. Those that were distressed in the manner you have told us, and blown up in the way you have told us, were they among the 25?—A. Yes.

Q. How many of the 25 were affected in this manner with distension and the symptoms you have mentioned?—A. There were four which were the worst, but the others were all affected; there were four very bad.

Q. Was there any difference between those four in their size, compared with the other beasts?—A. They were about the same size.

Q. How are they fed—is there more than one animal at a trough?—A. There are three tied up in a wide stall and they are fed in troughs.

Q. Of the four that were worst were they tied up three in one stall?—A. No; there was two in one and the others were odd ones; they were not both together, they were amongst the rest.

Q. Well, I suppose you know that some cattle like other things may sometimes get a better share than others, in spite of any provision you may make?—A. Yes I know a little about it.

Q. Is not that so, that some get a little more than their share?—A. Yes, sometimes they do.

Q. Some eat a little faster and enjoy their food more?—A. They cannot reach very well.

Q. But they do sometimes?—A. The middle one may get a little more sometimes, but they cannot reach very well.

*Re-examined by Mr. FIELD.*

*Q.* Each beast is tied up is he not?—*A.* Yes.

*Q.* And is he so tied up as, as much as possible, to give each of them the same amount of food?—*A.* Yes.

*Q.* Can one get hold of very much more out of his neighbour's dish?—*A.* Not much.

*Q.* My friend asked this; when they have been off for ten days you say you gave them 7 lbs.—when they were off on the second occasion you gave them 7 lbs. also.

*Mr. SEYMOUR:* That is a very leading question.

*Mr. Justice BLACKBURN:* It is what I understood him to say.

*Mr. FIELD:* Can you give me a notion of about the weight of these beasts?

*A.* 60 Stone—some 70 perhaps.

*Q.* Fine large beasts?—*A.* From 60 to 70 Stones.

GEORGE SPIVEY sworn: *examined by Mr. MELLOR.*

*Q.* Are you in Mr Wells' service?—*A.* Yes.

*Q.* How long have you been with him?—*A.* Thirteen years.

*Q.* Do you attend to the cows and young cattle?—*A.* Yes.

*Q.* At Booth Ferry?—*A.* Yes.

*Q.* In February last how many had you under your charge?—*A.* I had eight cows, three yearling bull calves, and two ten-month old heifers.

*Q.* How did you feed them—what was the system?—*A.* The first thing in the morning we were milking till six o'clock, then we gave them some chopped straw and hay. Then about nine we gave them half a bushel of mangold wurzels apiece.

*Mr. Justice BLACKBURN:* What next?—*A.* We turned them out in the fold yard to get water. Then by half past one or near two fetched them in again to have half a bushel more of mangold wurzels; then about three, gave them 6 lbs. of cake.

*Mr. MELLOR:* anything more?—*A.* I did not give them anything more that day.

*Q.* Do you remember the one ton of cake coming from Goole Station?—*A.* Yes.

*Q.* At that time how long had the cows been without cake?—*A.* Four or five days.

*Q.* After the cake had arrived and been broken up did you feed your cows?—*A.* I fed them in the same way.

*Q.* Who broke up your cake for you to feed your cows?—*A.* George Tutty.

*Q.* Now tell us what took place?—*A.* I gave them the cake at the usual time.

*Q.* How much?—*A.* About 6 lbs.

*Mr. Justice BLACKBURN:* 6 lbs each?—*A.* Yes, and then I had occasion to fetch some water to some bulls and as I was going by the cowhouse door I found them housing sadly.

*Mr. Justice BLACKBURN:* I suppose that means moaning; but I do not know the word.

*Mr. MELLOR:* What did you do?—*A.* I put my water down, and went into the cowhouse, and found a white cow in great pain, and blown up; and then I found the red one stood beside her in the same way. Then I went to George Tutty and fetched some train oil, which Mr. Wells requires us to give when the beasts are blown up; and when I got to George Tutty, I found that he was in the same position with his beasts as I was, and he lent me the oil bottle, and I came back again to the cows, and got a man to help me to give

them some oil. Well, when we were giving those two some oil, I turned myself round, and I found one that was worse blown up than the other two.

Mr. Justice BLACKBURN: Do you mean a third cow?—A. Yes. Then I went to the back side, to look at the young stock, and I found one young bull-calf sadly blown up. Then we came back again to the cows, and found them all rather blown up, and started and gave them all oil.

Q. How did they go on?—A. The third one appeared to be worse, and I stood beside the third one, and the man that helped me to give the oil went to the other two, and we put our fingers in their mouths to make them get wind, so that it would ease them of pain. Then I found out that the cow that I was against would die, and I sent the other man out to go and send for somebody to see for the butcher to come.

Q. And did the butcher come?—A. No, he did not come till after.

Q. Till after the cow died?—A. No.

Q. About how long after you had fed her did the cow die?—A. About an hour.

Q. Did the others get any better that day?—A. Yes; after Mr. Wells came home he ordered us to turn them out in the grass close.

Q. Could you milk them the next day?—A. Yes we milked them, but we had to throw away the milk, and they gave very little.

Q. What sort was it?—A. It looked the same as the rest did, but we dare not use it; we were frightened, and it was taken and thrown away.

Q. Did you notice the dung?—A. Yes; it smelt very strong, and black.

Q. Well, you did not give them any more of this cake, I suppose?—A. No.

Q. How long were they without cake after this?—A. Why I should say myself for a fortnight.

Q. Till the fresh cake came?—A. Yes.

Q. When the fresh cake came did you feed them as usual?—A. Yes.

Q. How did they go on?—A. They went on all right. I never saw anything.

Q. After this fresh cake had come, and they went on all right, were they without cake a second time?—A. No, my beasts were not without any more right away till we turned them out to grass.

*Cross-examined by Mr. SEYMOUR.*

Q. You say it was a fortnight before they got cake again?—A. Yes.

Q. Tutty has been here, and tells us that they had fresh cake in about five days again. Had not you a supply of cake within a week after the cow died?—A. No. I should say it would be most of a fortnight.

Q. I am asking you, had not you a supply of cake within a week after the cow died?—A. No.

Q. Have not you any means of telling—do you keep no books?—A. No, I do not.

Q. Then you are only judging from your memory?—A. Yes.

Q. I suppose Mr. Wells could tell us?—A. Well I should say he could.

Q. How long had you been out of the cake before you began to use Mr. Ayre's cake or Mr. Kidd's cake?—A. About five days.

Q. Come a little more?—A. No.

Q. Not ten?—A. No.

Q. How do you know?—A. Because the other man always leaves me some for the cows and calves when we are likely to run short.

Q. Now, how did you measure the cake you gave the cows?—A. We have a bushel scuttle to measure it.

Q. You say about six pounds—I suppose it might be a little over?—A. I do not think it would. I should say it would be a little under if anything.



Q. You say, if anything, there could not be a little over six pounds?—

A. Well, there might be, and there might be a little under.

Q. One beast might get a little more than the others by chance?—A. Well, it might; but I have fothered them so long that I know as near as can be.

Q. And some enjoy it more than others?—A. Oh, I reckon to give them all alike as near as possible.

Q. You give them mangolds also?—A. Yes.

Q. Where did you take your mangolds from?—A. We have a shed on purpose to keep them in.

Q. With walls round it, or an open shed?—A. Yes, with walls round it, and a door to it.

Q. You speak of it as a shed—I want to know.—A. Yes.

Q. Is it in a room?—A. It is in a room.

Q. How long had the mangolds been there?—A. Three or four days—perhaps a week.

Q. They had been brought from the field?—A. Yes.

Q. Then they were fresh mangolds?—A. They were fresh out of the pile—they had been piled up awhile.

Q. There is only one other point I wish to have from you. I think you say that you fed the cows with cake, and you went to fetch water—where did you go to?—A. Across the yard, about forty yards.

Q. What sort of weather was it at the time—it was the 16th of February—just recollect what sort of weather it was?—A. I know it rained that night.

Q. But you had had some frost had not you shortly before?—A. Well, I cannot say.

Q. What is your recollection—do you recollect?—A. No, I do not recollect that there was any frost.

Q. You do not recollect one way or the other?—A. No.

Q. You keep some train oil to give the cows when they get distended?—A. Yes.

Q. They do sometimes get distended do not they?—A. Well, the beasts that get potatoes do.

Q. And when they get distended, they get uneasy, do not they?—A. Yes.

Q. And the coat gets rough—stares a little?—A. Yes, and they fill up.

Q. And they house, don't they?—A. Yes.

Q. And then you give them train-oil, and if the case is not a bad one it improves them?—A. Yes.

Q. And I suppose you find that some cows who eat potatoes eat more heartily than others?—A. My cows never get any potatoes.

Q. I understood you to say just now that you have had cases of distension?—A. Yes, the other man has, that I have helped him in—Tutty.

Q. Have you sometimes seen them distended from mangolds?—A. No.

Q. Clover?—A. No.

Q. Only from potatoes?—A. Only from potatoes.

Q. From turnips?—A. Well, I have never seen them blown up from turnips, unless they get choked.

Q. Just tell me again what you gave your cows to eat?—A. Chopped straw and hay, and mangold wurzels, and then turn them out in the fold-yard to water.

Q. I think you gave them clover?—A. Clover-hay, and straw, all chopped up together.

Q. Was there clover with the hay and straw?—A. Yes.

Mr. FIELD: Clover-hay; not clover.

Mr. SEYMOUR: Well, clover-hay if you please—chopped up with the straw?—A. Yes.

Q. And any mangolds?—A. No. I did not give them any more mangolds till I fetched them in about two o'clock.

Q. When did you give them mangolds that day?—A. Pretty near nine o'clock.

Q. How often did you give them mangolds that day?—A. Twice.

Q. The same mangolds that you tell us of, taken from the shed, that had been brought in three or four days before from the heap?—A. Yes.

*Re-examined by Mr. FIELD.*

Q. The mangolds are drawn in October?—A. Yes.

Q. And then they are heaped in piles, and then brought some four or five days before you want them in the shed?—A. Yes.

Q. And you take them from the shed?—A. Yes.

Q. Are they thatched over in the piles?—A. Yes.

Q. Now tell me how long before you gave them the cake had you fed them with chopped clover-hay?—A. Between eight and nine in the morning.

Q. How long before you fed them with the cake had you fed them with the mangolds?—A. About an hour or an hour and a half.

Q. Were they perfectly well when you first gave them the cake?—A. Yes.

Q. No symptoms of anything at all?—A. No symptoms of anything at all.

GEORGE CALVERT sworn: *examined by Mr. FIELD.*

Q. Are you farm bailiff to Mr. Wells?—A. Yes.

Q. At Airmyn Pastures?—A. Yes.

Q. How many years have you been his farm bailiff there?—A. Twenty-seven.

Q. What number of beasts is it your practice to stall feed there?—A. Our usual practice is to tie up from sixteen to twenty-three or twenty-four.

Q. What is your practice with regard to the feeding beasts? How much do they usually get?—A. Do you mean cake?

Q. Yes?—A. About 7 lbs. per head is the general practice.

Q. What time of the year are the beasts generally tied up?—A. From October to November, and sometimes earlier too.

Q. What is your course of feeding? What time do you begin in the morning, and what is your course of feeding through the day?—A. We give them cake the first thing in the morning.

Q. About what o'clock do you give them their cake?—A. About half-past six to seven.

Q. In February and March do you give it so early as that?—A. Yes.

Q. What is the next thing?—A. We give them either turnips or potatoes.

Q. When?—A. At half-past eight.

Q. How much?—A. About a bushel, I think. What we call a bushel.

Q. What is your next operation?—A. Straw.

Q. Chopped straw?—A. No.

Q. Straw to pick over?—A. Straw to pick over.

Q. When did you give them that?—A. As soon as they have got the turnips eaten.

Q. What next?—A. Turnips at eleven o'clock.

Q. The same quantity as in the morning?—A. Yes.

Q. What next?—A. Between three and four, turnips again.

Q. Is that all they get?—A. Straw.

Q. And that is all? They amuse themselves with the straw—they pick it over?—A. They eat it. We lay it against their heads.

Q. What number of beasts did you tie up this last October?—A. Twenty-two.

Q. Feeding beasts?—A. Yes.

Q. Had you any beasts that you gave cake to besides the feeding beasts?—A. No.

Q. And what quantity of cake have you given to these feeding beasts since October—how much per day?—A. About 7 lbs.

Q. Had those beasts come up from grass?—A. Yes.

Q. Do you recollect the 16th February, when you gave them the cake that came from Goole—the cake in question?—A. Yes.

Q. How long before that had you been out of cake?—A. From ten days to a fortnight.

Q. Did you see the cake arrive at Airmyn Pastures?—A. Yes.

Q. Where was it put?—In the cake house, where we always put it.

Q. What time in the day did it arrive?—A. Between four and five o'clock—five, pretty near.

Q. When was it broken up?—A. We break it up of a morning as we want it.

Q. Where do you break it up?—A. In the cake chamber.

Q. By a hand machine?—A. By a hand machine.

Q. Did you break it up that morning?—A. A man that fed the beasts did.

Q. Dendy?—A. Yes.

Q. Were you there when he did it?—A. No.

Q. The cakes are whole, I suppose; the usual size of the large flat cakes, I suppose? About how many pounds would there be in each cake?—A. About 8½ lbs., or something like that.

Q. What cake did you give them on this day?—A. I went into the chamber when it arrived, and I said, "Now, Dendy, be careful about this cake; I do not like the look of it."

Q. How much cake did you actually give the beasts?—A. I ordered them not to exceed 4 lbs.

Q. Did you see him feed them?—No.

Q. Whom did you send to Goole for the purpose of fetching the cake?—A. John Hepton.

Q. How soon after the beasts had had their cake did you see them in the morning?—A. About an hour after.

Q. Tell us the state you found them in?—A. I found them all with their tongues out, standing with their legs partly together, and blown up—slabbered.

Q. How many of them did you find in that condition?—A. All.

Q. Were any of them worse than the others?—A. There were two that were worse than any of them.

Q. Can you describe those two to me by colours or marks? Can you tell me whether they were red or white? Can you give me any idea?—A. They were red and white.

Q. In what degree were they worse?—A. Well, they looked to be a deal worse, you know.

Q. Did you give any of them oil?—A. No.

Q. None of them at all?—A. No.

Q. Why not?—A. Because I thought I would try without.

Q. What did you do with them?—A. I did nothing but turn them out.

Q. Into the fold yard?—A. Yes.

Q. What happened to them?—A. They began to get better.

*Q.* How long were they getting round?—*A.* Three or four hours.

*Q.* And how long were they before they got well?—*A.* They took a little food that night.

*Q.* Next day?—*A.* Next day they ate.

*Q.* When did you see Mr. Wells—the same day?—*A.* No, not the same day—the next day.

*Q.* Did you give them any more of that cake?—*A.* No more.

*Q.* Did you give them afterwards some fresh cake?—*A.* We had no other cake.

*Q.* Did you some time afterwards give them some fresh cake that came in?—*A.* Yes.

*Q.* How long afterwards?—*A.* A week, I think, nearly.

*Q.* What quantity did you give them of the fresh cake, when it came in, at a feed?—*A.* We gave them the usual feed.

*Q.* How many pounds?—*A.* Six to seven pounds.

*Q.* Did that do them any harm?—*A.* No.

*Q.* Were you some time afterwards out of cake again?—*A.* We were not, I think, after that turn—after we got a fresh lot.

*Q.* Were not you some time after that out of cake again for a short time?—*A.* Yes, for a short time.

*Q.* For how long were you?—*A.* Well, perhaps three or four days.

*Q.* And then you had fresh cake in?—*A.* Yes.

*Q.* And then did you give them the same quantity again?—*A.* The same quantity again.

*Q.* And were they any the worse for that?—*A.* Never.

*Cross-examined by Mr. SEYMOUR.*

*Q.* Those two that were worse than the others, were they in the same stall or different stalls?—*A.* They have each their own stall.

*Q.* During the time between their having this cake and the next cake what did you feed them on?—*A.* When we had not cake?

*Q.* Yes—about a week. You say you got the other cake in about a week after you saw the cattle ill?—*A.* Yes.

*Q.* What did you feed them on meantime?—*A.* Turnips and straw.

*Q.* Did you increase the quantity of turnips?—*A.* No, I do not think we did much.

*Q.* Chopped straw?—*A.* No; straw as it comes from the threshing machine.

SAMUEL DENDY sworn: *examined by Mr. MELLOR.*

*Q.* Are you in the service of Mr. Wells?—*A.* Yes.

*Q.* At Airmyn Pastures?—*A.* Yes.

*Q.* How long have you been in his service?—*A.* I have fed beasts for him thirty years.

*Q.* Do you remember a ton of cake coming from Goole?—*A.* Yes; I took it in.

*Q.* And did you feed the beasts the next morning?—*A.* Yes.

*Q.* And what quantity of cake did you give them?—*A.* What, of that that came from Goole?

*Q.* Yes?—*A.* Why as nearly four pounds as I could guess it; it might be a little bit over, or a little bit under.

*Q.* What time was it when you fed them?—*A.* It might be half-past seven or nearly eight in the winter-time.

- Q. When did you next see them after that?—*A.* About an hour.  
Q. What state were they in?—*A.* All amiss, shaking all over, with the tongues out and blown up much.  
Q. You heard what the last witness said about it?—*A.* I always fed them myself.  
Q. Did you hear Mr. Calvert when he was in the witness-box?—*A.* Yes.  
Q. Did he give a true account of the state in which they were?—*A.* He did.  
**Mr. SEYMOUR:** I do not ask you anything.

JOHN HUTCHINSON sworn: *examined by Mr. FIELD.*

- Q. Are you a butcher at Airmyn?—*A.* Yes.  
Q. Have you been brought up with cattle all your lifetime?—*A.* Yes, I have.  
Q. And have you been in the habit of looking at Mr. Wells' cattle when anything is amiss with them?—*A.* Yes, I have.  
Q. Do you recollect going down last February to Booth Ferry?—*A.* Yes, do very well.  
Q. What state did you find the stock in?—*A.* I found them in a very bad state indeed.  
Q. Was the cow dead then?—*A.* She was dead, and they were just pulling her out into the field when I got there in my cart.  
Q. Tell me, generally, what was the matter with the cattle—what were they suffering from?—*A.* They were all blown up, more or less, through the whole lot; but some four or five or six were worse than the others, and standing with their tongues out.  
Q. Did you look into their manger?—*A.* No.  
Q. Did you look into the rack?—*A.* No, I did not.  
Q. Did you see whether they had eaten all their cake or not?—*A.* I really did not see that.  
**Mr. SEYMOUR:** I do not ask you anything—I do not dispute that they were blown up.

NICHOLAS DEAN sworn: *examined by Mr. MELLOR.*

- Q. Are you farm bailiff to Mr. Wells at Sancton?—*A.* Yes.  
Q. How long have you been with him?—*A.* Ten years.  
Q. In February had you any feeding beasts at Sancton?—*A.* Yes.  
Q. How many?—*A.* Five.  
Q. On the 8th February had you five tons of cake from Hull?—*A.* From Market Weighton—Hull cake I suppose.  
Q. Are the beasts at Sancton fed often there?—*A.* Well, they generally come to Booth Ferry to get fed up at last.  
Q. How have you been in the habit of feeding the beasts at Sancton—how much cake have you given them?—*A.* About three pounds as near as I can tell.  
Q. Besides the cake, what else did you give them?—*A.* Swede turnips and raw.  
Q. Did you give them the Swede turnips before you gave them the cake, or the same time?—*A.* Before.  
Q. How long before?—*A.* Perhaps two or three hours.  
Q. About what time of the day was it when you gave them the cake?—*A.* About ten o'clock—between ten and eleven generally.  
Q. In the morning?—*A.* In the forenoon.

Q. What was the next meal you gave them after giving them the cake?—  
A. Swede turnips.

Q. Swede turnips again?—A. Yes.

Q. How long after the cake?—A. About twelve o'clock—just dinner-time.

Q. Of the five tons that came on the 8th February, how much cake did you give of that quantity—how much to each beast per day?—A. About three pounds.

Q. Did you give them anything else beside the turnips?—A. Swede turnips and straw.

Q. When did you give them the straw?—A. We bedded them with it regularly. It came from the machine—they could eat it when they liked.

Q. Could they eat it at any time in the day?—A. Yes.

Q. Did you mix anything with the cake, or give them the cake without?—A. Very often a little oat-chopping.

Q. What quantity of oat-chopping did you mix with three pounds of cake?

—A. Well, I cannot say; I put the bit in a corn-scuttle.

Q. About how much?—A. I am sure I cannot tell—perhaps half a peck, or nearly a peck.

*Cross-examined by Mr. SEYMOUR.*

Q. Had you been without cake at Sancton?—A. Yes.

Q. How long?—A. I am sure I do not know—ten days or better perhaps—between ten days and a fortnight.

Q. And then you gave daily three pounds of cake?—A. Yes.

GEORGE WELBURN sworn : *examined by Mr. FIELD.*

Q. Are you a shepherd at Sancton?—A. Yes.

Q. Do you recollect this cake coming in?—A. Yes.

Q. Did you give some of it to the sheep?—A. Yes.

Q. What did they say to it?—A. They would not have it.

*Cross-examined by Mr. SEYMOUR.*

Q. What had they been having—I suppose they did not like it so much as what they had been having?—A. No.

Q. What was it they had been having?—A. Cake.

Q. But you had been out of cake?—A. Yes.

Q. For ten days they had not been having cake?—A. They had not.

Q. What had they been having?—A. Chopping and turnips.

Q. And they preferred the turnips?—Very well.

*Re-examined by Mr. FIELD.*

Mr. FIELD: Had you been in the habit of feeding the sheep with cake?—  
A. Yes.

Q. And when you got fresh cake in, did they eat that?—A. No.

Q. Not this one afterwards?—A. No.

Mr. Justice BLACKBURN: Did they refuse to take it as before or did you not offer it to them?—A. Yes, we gave it to them and they put it into their mouths and put it out.

Q. Not merely these five tons of February, but they afterwards got fresh cake?—A. Yes, they ate that.

Mr. FIELD: How many days had you been without cake before the fresh cake came in?—A. Ten days, or from that to a fortnight.

Q. And then you had fresh cake in?—A. Yes.

Q. Did they eat that?—A. Yes.

Mr. SEYMOUR: But they took to the fresh cake too although they did not like it at first?—A. Yes, I mixed it with chopping.

Q. They had been eating chopping and then you mixed it with cake and they took it?—A. Yes.

Q. And it did them good?—A. Well, that I cannot say.

Mr. Justice BLACKBURN: How do you generally give them the cake—with chopping or raw?—A. The first thing in the morning by itself.

Q. This cake in question the sheep would not eat?—A. No.

Q. Then you mixed it with chopping and they did eat it?—A. Yes, part of it.

Q. Then with the new cake afterwards, did they eat that without the chopping?—A. No, they ate it with chopping afterwards, but not by itself.

Q. I mean not the five tons but what came afterwards—did they eat that with chopping or by itself?—A. Yes, they ate that by itself.

JOHN HEPTON deposed to fetching a ton of cake from a truck in the warehouse at Goole Station to Airmyn Pastures Farm.

THOMAS BUTTLE deposed to fetching another ton from Goole Station to Booth Ferry.

WATKIN WILLIAMS WINN, Station-master at Goole, proved the arrival of a waggon from Wilmington, containing the cake for Mr. Wells, and that the cake was in the same condition when delivered as it was when received.

WILLIAM COPELAND, Station-master at Wilmington, proved the loading of the waggon with cake and that, before loading, the waggon was swept out and bedded with clean straw.

GEORGE SIMPSON, clerk to Mr. Wells, said that on the night the cow died, he got a sample of the cake from the cake house, packed the sample in a washed guano bag and addressed it to Dr. Voelcker. Some time in March he sent to London another parcel of the cake from Airmyn Pastures, and afterwards sent a third parcel.

HENRY SMITH Esq., of Eske Hall, Durham, a magistrate for the county of Durham, was called to show that the system of feeding, adopted by Mr. Wells, was a proper and suitable one, but his evidence was objected to by Mr. Seymour.

Dr. AUGUSTUS VOELCKER sworn: *examined* by Mr. FIELD.

Q. What are you Dr. Voelcker?—A. I am a Doctor of Philosophy.

Q. And Chemist?—A. And analytical Chemist—Professor of Chemistry.

Q. How many years have you been practising as a Chemist?—A. I was for fourteen years Professor of Chemistry in the Royal Agricultural College of Cirencester, and for 15 years have been Consulting Chemist to the Royal Agricultural Society, and I am a Fellow of the Royal Society.

Q. In your capacity of Consulting Chemist are you in the habit of receiving or examination a considerable number of samples every year of linseed or so-called linseed-cake?—A. Yes, a great many—usually from between 150 to 200 samples in the course of the year.

Q. And do you analyse what is sent to you?—A. Yes, I do.

Q. What is the linseed-cake made from?—A. Linseed-cake ought to be nothing else but the expressed linseed—the pressed cake—linseed after the oil is expressed; but what linseed-cake really is, as it is sold, that is another question.

Q. We will go step by step. Does the linseed-cake, so expressed, contain, when it is genuine, any admixture of foreign seeds, and if so, what is the ordinary admixture of foreign seeds in the linseed that is so the result of the pressing?—A. Pure linseed ought not to contain more than from four to five per cent. of foreign seeds. It sometimes contains less, but the best pure

linseed cake perhaps does not contain more than from two to three per cent. of seed admixtures.

Q. Is that linseed you are now speaking of the linseed as it comes from the Black Sea, or had it undergone any process of screening or sifting?—A. It usually has to undergo the process of screening or sifting.

Q. Where is that performed?—A. It is performed in England.

Q. By whom—by what class of merchants—who is the person?—A. By the manufacturer of pure linseed-cake.

Q. By the crusher?—A. By the crusher.

Q. And what do the screenings and the siftings consist of?—A. The screenings or siftings consist of a variety of small weed seeds. I have counted as many as 29 to 30 that I could identify; then you find in the siftings more or less dirt and accidental impurities of that kind, but they chiefly consist of a variety of weed seeds.

Q. Among the seeds that are so found in the linseed, will you give me the names of those which you find in them generally—some few—*Chenopodium*, what is that?—A. That is the scientific name for spinach—perfectly harmless seeds, and there are a good many other harmless seeds amongst the small weed seeds; but there are also others which are decidedly injurious, for instance, the black mustard or wild mustard, charlock or ketlock, as it is called in some parts of England—it is a pungent seed.

Q. Any other?—A. Then there is the *Lolium temulentum* or drunken darnel, that is reputed to be a poisonous seed; and there is the corn-cockle.

Q. There are seeds of that kind which contain injurious properties?—A. The purging flax, and the flax dodder which is of a doubtful character.

Q. You have examined dirty linseed—what percentages have you found of these wild seeds in them?—A. In commercial samples the percentages vary from 5 to 70. I have examined some samples of “genuine linseed” which had only 30 per cent. of linseed in them, but that is a bad or third quality. Usually you do not find perhaps more than 20 or 25 that would be perhaps called a fair sample of genuine linseed.

Q. Now tell me as a Chemist, are you able, on looking at cake or analysing it, to say whether it will produce injurious effects?—A. No, I could not say as a Chemist.

Q. Chemical science does not enable you to say that?—A. No, it is impossible to do that. It is only by the effects that the injurious properties of these impurities manifest themselves: but I know as a fact that cakes made of the siftings have caused the death of animals in several instances that have been brought under my notice. Indeed the cakes were sent to me for examination and I could not find anything else but the siftings—it was a complete sifting cake. They were what is technically called “siftings cakes” and all Hull crushers will know what “siftings cake” means.

Q. The examination of this chemically would not enable you to say any thing, but only the effects which they produce?—A. Only the effects which they produce. That is to say, I could identify some of these poisonous or injurious seeds, but I could not identify the poison in them.

Q. You received a sample from Mr. Wells?—A. Yes, the sample in the bag.

Q. Before I come to that perhaps I ought to ask this: Have you had experience in reference to mouldy seeds or mouldy cakes that have been ground up to mix with other cakes?—A. Oh, yes, I had a case only last week.

Q. Tell me, what was the effect of that grinding-up and mixing mould cake with another cake?—A. Mouldy cake in many instances produces serious injury to the stock. It produces just the same effect upon animals as mould bread or bread kept in a damp cellar or ill-ventilated pantry will have on the human subject, very poisonous. I do not mean to say that a superficial slight



mould, which can be easily rubbed off, is poisonous; but if the mould penetrates thoroughly the cake, I should not like to give it to my cattle.

Q. But the mouldy cake has been ground up and mixed with the other cake?—A. Yes.

Q. Tell me also with regard to the sesamé-cake; that is ordinarily sold as cake?—A. Sesamé is sold as cake to manufacturers. I do not think there is one farmer in a thousand who knows what sesamé-cake is, because it never reaches his hands. It is all used in the manufacture of linseed-cake. I know the cake very well. Here is a specimen of it.

Q. Mr. Ayre told us that the sesamé itself goes to make salad oil?—A. Yes, and a very sweet oil it is too. The sesamé-cake is good feeding cake, too, if it is in good condition.

Q. Then the crushers here buy it, and mix it with the linseed cake?—

A. It is manufactured into linseed-cake. There are a good many foreign cakes which never reach the farmer, and which are not known to him. They are all manufactured into linseed-cakes, and unfortunately some of these cakes get damaged during the passage to this country; they get sea-damaged, or they heat, and then they become spoiled and unfit for food. Well, then they are bought up at cheap prices by the cake manufacturers—the manufacturers of mixed cake—and frequently they do harm.

Mr. SEYMOUR: You are not here to make a speech against manufacturers.

Mr. FIELD: Have you examined this particular cake?—A. Yes, I did examine it.

Mr. Justice BLACKBURN: The sample in the bag?—A. The sample in the bag.

Q. Did you make an analysis of it?—A. Yes.

Mr. FIELD: And did you also make a microscopical examination of it?—A. Yes.

Q. Did you do that by yourself, or with the assistance of anybody else—in the first instance? I mean that particular sample?—A. The analysis by microscopical examination I did myself, but in the chemical analysis I was assisted.

Q. By your own assistant?—A. Yes.

Q. Not with any other chemist?—A. No, it was done in my presence.

Mr. SEYMOUR: You are now speaking of what took place before the libel was published—not afterwards?

Mr. FIELD: Yes. (To the Witness) Tell me what you found upon analysis that this cake consisted of?—A. I found in the first examination—I did not find at once the sesamé-cake—that it was anything but genuine linseed-cake.

Mr. Justice BLACKBURN: Tell us what you did find?—A. I found in it a great variety of weed seeds, amongst which I may mention the following: *Cotium temulentum*, grass seeds, and spurry seeds, which is very common in linseed—*Chenopodium*. This is a copy of the notes I made at the time. Then I found bran and barley husks, oat husks, rice husks, rye and tail wheat, some whole grains—then a very common weed amongst linseed—knot-grass (*Polygonum aviculare*), bind-weed (*Polygonum convolvulus*), then some few millet seeds, wild mustard or charlock, dodder seed; then I found a few husks of cotton seeds and cocoa-nut, and some other material, but I could not make out what it was, but which I have since found is sesamé-cake. In fact, it was mentioned to me that it might contain sesamé, and then I looked for it and found it; I could not find it before.

Mr. FIELD: You have spoken of cocoa-nut-cake and rice dust?—A. Rice husks; it comes to the same thing.

Q. Are those things that belong to linseed at all?—A. No, they do not belong to linseed.

Q. They do not grow with the linseed?—A. No, they do not. I infer from their presence this. I may say I do not think the cake is mixed purposely with these materials, but I found them in it, and it is most likely they occur in the general sweepings of the warehouses from which these materials are generally gathered.

Mr. Justice BLACKBURN: You have mentioned finding all these, but you have given us no mention of the proportions?—A. No, my Lord, I could not possibly determine what proportions they occur in. I only know by the number that there is probably a large proportion of them.

Mr. FIELD: And besides those that you were able to detect in examination if they had been crushed up with the rest of the cake you would not be able to discover them?—A. That is quite certain.

Q. In your judgment, from the examination you made of that cake; what was the cake composed of?—A. Well, it appeared to me that the cake was composed of sesamé-cake and bran, and general warehouse sweepings, with some linseed, which had been very imperfectly crushed. I found a large proportion, as far as I could judge by the eye, of uncrushed linseeds than in any really pure linseed-cake. And I may mention—

Q. Before I go to the mode of manufacturing cake, have you anything more to say about the elements of which the cake was composed?—A. Nothing more.

Q. Were you able to detect in the cake any positively poisonous matter?—A. No, I was not; except some of those poisonous seeds which I have mentioned before.

Q. Now tell me with regard to the mode of manufacturing the cake. You said just now that you found whole linseeds that had not had the oil crushed out of them?—A. Yes, and in a much larger proportion, as far as I could judge by the eye, than in pure linseed-cake.

Q. The oil, of course, is the profit of the oil crusher. What would that indicate if he leaves seeds with the oil in them?—A. Well, it is done for that purpose—

Mr. SEYMOUR: Really, I must object to that.

Mr. Justice BLACKBURN: It is an inference he may draw from it, and you may ask a man of skill instead of leaving the Jury and myself to draw it.

The WITNESS: It is done for the purpose of giving the mixture of sesamé and bran and other materials the appearance of linseed-cake, that is the ostensible reason. It is just like in the manufacture of bone super-phosphate throwing into the dissolved coprolites a few whole bits of bone, and the farmer sees the bone and thinks it is really nothing but dissolved bones. It is an analogous case.

Q. Did you find the cake agglutinated in globules or fragments?—A. I found some little bits of hard nodules.

Q. What did they indicate?—A. It shows that there are some materials mixed up and ground with it, and that it is not a genuine linseed-cake.

Mr. Justice BLACKBURN: How does it show that? Explain, how do the nodules show that?—A. If the cake were crushed from mere linseed, you would not find those separated specks or nodules in the cake, but you would find it of a more uniform character.

Mr. FIELD: What is the process by which the oil is expelled from the linseed?—A. The linseed is first crushed, and then ground under rollers, and then pressed.

Q. All the oil is pressed out of it?—A. The greater portion of the oil is pressed out.

Q. And the linseed is left as the residuum?—A. The linseed-cake is left the residuum.

Q. Have you given us the result of your microscopical examination, as was

s the chemical examination?—A. I do not think I have given you the chemical examination.

Q. Give us the analysis, please?—A. I have got it here.

Mr. Justice BLACKBURN: When was this made?

Mr. FIELD: The 2nd of March. (To the Witness) Was this made by yourself at the same time?—A. Yes, it was made at the same time:

Moisture .. .. .	13·57
Oil .. .. .	13·06
Albuminous compounds .. .. .	27·68
Starch, mucilage, and digestible fibre ..	25·68
Woody fibre .. .. .	11·52
* Mineral matter .. .. .	8·49

Total 100·00

\* 2·20 of the last consisted of sand.

Q. That is part of the other?—A. That is part of the mineral matter.

Q. Is that a larger or smaller percentage of the mineral matter than you ordinarily find in linseed-cake?—A. It is rather larger.

Q. What is the average ash?—A. The average ash is about 6½. It does not much affect the quality of the cake.

Q. What was the next analysis you made?—A. I examined the whole cake.

Q. What was the date of your next examination?—A. The next examination I made on July 16th.

Q. Was that with Professor Way?—A. Yes, in conjunction with Professor Way. We examined it together.

Mr. Justice BLACKBURN: The matter in the bag of which you have been speaking was a different sample altogether?—A. The same cake which I received in the bag—this cake; and also a second sample, part of a whole cake.

Mr. FIELD: On the 16th July, you made another analysis with Professor Way?—A. Yes.

Q. First of the cake that you have in the bag?—A. Yes.

Q. Where is the other?—A. I have the other here—part of this cake (pointing).

Q. Is there any mark of what it is?—A. It is marked “part of two lots.”

Q. When did you receive it?—A. I received it from Mr. Jenkins, who brought the cake to my laboratory.

Q. When was that?—A. In June, I think, or July. It came from Airmyn Pastures Farm. This is Mr. Wells’ handwriting, who sent it at the same time that those two cakes came.

Q. I do not know whether you made any analysis of the Sancton cake?—A. Yes, I examined the Sancton too.

Mr. Justice BLACKBURN: Not at this time?—A. No. The Sancton came at the same time.

Q. Then did you, with Professor Way, examine all three?—A. No; I only examined this cake, which Mr. Wells sent me direct to the laboratory, which call the “broken cake,” and also the whole cake, which was handed to me by Mr. Jenkins.

Mr. Justice BLACKBURN: That comes from Airmyn Pastures? Very well. We will get this first, and then we will go to the other afterwards.

Mr. FIELD: Tell me what you found, on examination of the first cake that you examined?—A. I found that they were identical, practically speaking.

Q. The Airmyn Pastures sample, and the sample which Mr. Wells sent you are practically identical?—A. Practically identical.

Mr. Justice BLACKBURN: Trying them by chemical analysis or as shown by the microscope?—A. We examined them by the microscope and I also determined by way of check the amount of albuminous matter and that did not differ very materially from the broken cake—it was rather richer in nitrogen, but essentially the same.

Mr. FIELD: Have you got there the analysis that you made on that occasion of each cake?—A. Yes I have.

Q. Do they substantially agree?—A. Substantially they are the same, the two together.

Mr. SEYMOUR: I would like to know whether the three were the same.

Mr. FIELD: I will come to that—do you wish to have this analysis put in, on the 16th July?

Mr. Justice BLACKBURN: No doubt it is desirable to know what was the analysis which was taken afterwards, on the 16th July, so as to compare the two.

Mr. FIELD: Read your analysis of the 16th July?—A. On the 16th July I only made a microscopical examination.

Q. No chemical examination?—A. No.

After some discussion between the judge and the counsel as to the documents to which the witness was referring, Mr. Field handed to the witness his original Report to Mr. Wells, 2nd March, which was read by

The ASSOCIATE as follows:—

Dear Sir,—I have submitted the cake which you sent me a short time ago, both to chemical analysis and to a microscopical examination, and enclose the results obtained in the analysis which however does not throw any light on the subject of the inquiry. The examination under the microscope on the other hand enables me to say that the cake which you sent me is not a genuine linseed-cake; for in addition to a number of small weed seeds such as the seeds of the *Chenopodium*, *Polygonum aviculare*, wild mustard, clover seeds, the seeds of the *Lolium temulentum* (drunken darnel), grass seeds, and other small seeds usually found in dirty linseed, I find in the cake, cotton seed husks, cocoa-nut-cake, rice dust, millet seeds, bran, and broken wheat. It appears to me to be made from dirty linseed containing the sweepings of granaries or seed warehouses, and unquestionably is not a genuine linseed cake. At the same time I am bound to say that I have been unable to detect in the cake any positively poisonous matter; I can, however, readily conceive that a linseed cake which is made, as most probably the cake you sent me is, from linseed or the sweepings of seed warehouses, may do serious injury to stock, for it is not at all unlikely that in such sweepings there may be injurious seeds, the injurious properties of which can only be detected by the effects they produce when cake containing these extraneous matters is given to cattle.

Mr. FIELD: That is the result you arrived at from the microscopical examination on the 2nd March?—A. On the 2nd March.

Q. Have you read the analysis which that contained?—A. Yes.

Mr. Justice BLACKBURN: What I understood to be read was the analysis made on the 2nd March: give us the copy of the analysis which was contained in that, and we shall see at once. Hand to him what you say was the original analysis enclosed. (A document was handed to the Witness)?—A. This is it.

Q. Is that the analysis which you enclosed in your letter to Mr. Wells?—A. Yes.

Q. And is that the same document which you read just now?—A. It is.

Mr. FIELD: Is that all you did on the 2nd of March?—A. That is all.

Q. Was the 16th of July the next time you made an analysis?—A. Yes.

Q. Did you also make a microscopical examination on the 16th?—A. I did.

Mr. Justice BLACKBURN: Nothing was done as I understand by you in the interval?—A. No, my Lord.

Mr. FIELD: What was it that you analysed and examined on the 16th of July?—A. On the 16th of July I re-examined the same cake in the bag, and also part of the whole cake.

Q. Was that of the whole cake that came from Airmyn Pastures?—A. I believe so.

Q. Have you got your microscopical examination that you then made?—A. Yes, I have got here a copy.

[The reading of the copy was objected to.]

Mr. FIELD: Can you tell me from your memory what it was that the cake contained?—A. I know from memory it contained bran, broken wheat, barley husks, rice husks and rye; the seed of the *Lolium temulentum*, or drunken darnel, wild mustard, and *Chenopodium* seeds.

Mr. Justice BLACKBURN: What is the English name of that.

Mr. SEYMOUR: I think it is Goose Foot.

The WITNESS: I believe it is so. Also Dodder, *Polygonum* seed—

Mr. Justice BLACKBURN: What is that?—A. Bind-weed and knot-grass, and also a few cotton husks and cocoa-nut husks.

Mr. SEYMOUR: Do you mean the word "few" to apply also to the cocoa-nut husks?—A. Only a few of both.

Mr. FIELD: And other seeds besides?—A. Other seeds besides, grass seeds and clover.

Q. Did you examine the cake for the purpose of finding these impurities together with Professor Way?—A. Yes, I did. I had the notes with me in Scotland, but, unfortunately, I find that I did not put them in my carpet-bag; I brought them all away from London.

Q. Have you made any further examination than those two that you have told us of on the 16th of July and in February and March?—Yes.

Q. When?—A. A few days afterwards. I believe it was on the 18th of July.

Q. Was that by yourself, or in company with anybody else.—A. By myself.

Q. Did you find any difference then; have you got the notes of that here?—A. I did not take any notes at the time.

Q. Did you find any difference then?—A. No.

Q. Have you made any other examination besides those?—A. I examined the cake again.

Q. When?—Last Tuesday.

Q. Did you make any notes of the examination then?—A. No, I did not make any notes.

Q. I am now going to ask you about what is called the "Sancton cake." When did you examine that?—A. I examined that also last Tuesday.

Q. Have you brought the notes of your examination of that?—A. I did not take any notes of that, because it was confirmatory of the other.

Q. When you examined the Sancton cake were you alone, or with others.—A. Alone.

Q. When was it you examined the Sancton cake?—A. Last Tuesday.

Q. And I understand you to say the result was the same as the others?—A. Yes, it was substantially the same cake.

Mr. FIELD: From these examinations your Report on the 2nd of March has been made. You adhere to what you say in that Report in your judgment as to the composition of this cake?—A. Yes.

*Cross-examined by Mr. SEYMOUR.*

*Q.* You adhere to your Report that the chemical analysis and microscopical examination do not throw any light upon the subject of this inquiry—that is, the inquiry into the death of these animals.—*A.* The chemical analysis.

*Mr. Justice BLACKBURN (To Mr. Seymour):* You put your question wrong.

*Mr. SEYMOUR:* I asked “microscopically,” too.

*Mr. Justice BLACKBURN:* I know you did, but the Report does not say so.

*Mr. SEYMOUR:* “I have submitted the cake which you sent me a short time ago both to chemical analysis and to a microscopical examination, and enclose the results obtained in the analysis, which, however, does not throw any light on the subject of the inquiry.”

*Mr. Justice BLACKBURN:* That is the result of the analysis, which does not throw light upon it; and that is what he has said just now.

*Mr. SEYMOUR:* The chemical analysis.

*Mr. Justice BLACKBURN:* Your question was, “Do you adhere to your Report that the microscopical and chemical analyses,” and so on.

*Mr. SEYMOUR:* Do you adhere to this—“At the same time I am bound to say that I am unable to detect in the cake any poisonous matter?”—*A.* That is so.

*Q.* And you have made altogether five examinations?—*A.* Yes.

*Q.* And is that the result to which you have come? Does that contain your opinion as the result of all your examinations?—*A.* That is so.

*Q.* Now, you say there may be injurious seeds, and I think you have referred to the drunken darnel. Is not that one of the seeds you mention?—*A.* That is one of them.

*Q.* Naturally or chemically speaking, is not it a narcotic?—*A.* It is supposed to be so; but we know very little about the true action of it.

*Q.* Still, I took it that that was one of the seeds you spoke of that might be injurious. Would not the injury depend upon the quantity, upon the percentage of it?—*A.* Quite so.

*Q.* Can you at all say what percentage you found?—*A.* No, there was not a large quantity.

*Q.* Can you give it in fractions?—*A.* No, I cannot.

*Q.* You cannot say what entity, what hundredth?—*A.* No, I cannot.

*Mr. Justice BLACKBURN:* I think you say that, though you cannot say what, it was not large?—*A.* It was not a large quantity.

*Mr. SEYMOUR:* And so small that he cannot give even the fractional proportion to the bulk. (To the witness.) What other seeds are there which you apply the term “injurious” to? Is there any other seed that has any narcotic power?—*A.* There is mustard which has a pungent power. I do not really attach much value to the presence of seeds in the cake producing the death of the animals.

*Q.* Then the quantity you found of any possibly injurious seeds you do not attach much weight to?—*A.* No, I do not really.

*Q.* Then we will go to what is left. With regard to the other subjects of your analysis, I find bran, oat-husks, and barley-husks. If there were bran intentionally used in a cake of that kind, you might expect to find a few oat-husks or barley-husks in the bran?—*A.* You do not usually find oat-husks in bran.

*Q.* Well, I suppose not, because the bran is cheaper than the oats, so you would not find much. But tell me to what extent did you find oat husks?—*A.* I could not mention any definite number. You could count them by the few, by the half-dozen, or the dozen.

*Q.* I want to know to what extent they were measured or discovered?—*A.* To the extent you find them in dirty linseed.

Q. I know that ; but we are talking of this linseed, and examining it more closely. I ask with regard to this linseed, did you find half-a-dozen grains of oat-husks?—A. Oh, yes, more than half-a-dozen.

Q. Did you find a dozen?—A. Well, I have not counted them.

Q. You spoke of grass and clover-seed. Do you find those sorts of seeds that are not injurious and are not narcotic even in pure linseed?—A. You find, as I mentioned, from 4 to 5 per cent. at most in pure linseed.

Q. Then what you would call pure linseed is that in which there is 4 to 5 per cent. of foreign vegetable matters or substances. In that you would find specimens of these weeds that you have mentioned?—A. Not in all of them. You do not find such a very great variety.

Q. Will you tell me what you do find?—A. You will find a few seeds, such as grass seeds.

Q. Do not you find *Polygonum*—knot-grass?—A. Yes.

Q. *Chenopodium* and dodder seed?—Yes.

Q. And the *Lolium temulentum*?—A. Yes, occasionally.

Q. Do not you find it in Calcutta seed of the purest brand?—A. No ; generally in St. Petersburg.

Q. Oh! generally in Black Sea?—A. Yes.

Q. But in both do not you find it?—A. I dare say it is found.

Q. Taking what you found, can you tell the Jury the proportion it bears in the cake?—A. It is impossible to determine that ; I can only form a judgment from the general appearance of the cake.

Q. You cannot form an estimate of the proportion it bore to the cake itself?—A. No, I cannot. I can only infer that it was a large proportion, as there was not much linseed. If there had been much linseed in the cake, the cake would have become gelatinous with water, which it did not.

Q. But by your test you were not able to discover sesamé in the cake?—A. No ; I dare say there are a great many things which I am not able to find in the cakes ; they are so finely ground now that it is almost impossible to say what may not be mixed in those compound cakes.

Q. You spoke of the linseed being whole—whole seeds of linseed?—A. Yes.

Q. Do not you see that even in the pure linseed-cakes?—A. Not generally to such a large extent.

Q. I will show you a cake of absolutely pure linseed, doubly and trebly screened (handing the same to the witness)?—A. Yes ; this looks a good cake.

Q. Well, assuming that to be, what I undertake, if necessary, to prove, warranted pure, do not you find those whole seeds about it—break a bit off?—A. Yes ; I find them— it is not usual.

Q. But you find the same condition of matters in the cake you have just broken?—A. Oh, yes ; I have found it out so in Bombay cake.

Q. Then in Bombay pure cake you do find pure linseed in a whole condition, containing whole seeds?—A. You do occasionally, but not as a rule.

Q. There you would not infer from the presence of linseed that it was done to deceive the eye of the farmer?—A. No ; I would not.

Q. The uncrushed linseed retains the oil, and therefore it would be to the interest of the crusher not to waste it?—A. Quite so.

Q. I take it of course that the moisture and woody fibre, and the mineral matter—the ash in the linseed—have nothing to do with the fattening or flesh-giving qualities of the cake?—A. No.

Q. I have been looking here at the result of your proportions, and I find first oil ; I presume that is an important element in the cake?—A. It is an important element.

Q. Then albuminous compounds?

[A copy of the analysis was here handed to the Judge.]

*Q.* There are albuminous compounds—flesh-forming matters—such as mucilage, sugar, and digestible fibre, as distinguished from woody fibre; these together form the other flesh-giving and nutritious elements in the cake, do not they?—*A.* Yes.

*Q.* I will now ask you this question: I find in this cake, which was sent up to you by Mr. Wells, a percentage of 13·06 of oil—is not that a very considerable percentage?—*A.* The analysis of a linseed-cake by itself gives no indication as to whether it is poisonous or not.

*Q.* I will not use the word “evasion,” but you must allow me to say that is not an answer to my question; you will kindly answer it. I am upon your analysis and your proportions. Is a proportion to the 100 of 13·06 of oil a good proportion so far as the oil goes, of nutritious matter?—*A.* It is a good proportion, and it is above the average of linseed-cake.

*Q.* Is 27·68 of albuminous compounds containing 4·43 of nitrogen, a fair average result?—*A.* It is a fair average result in linseed-cake.

*Q.* Is 25·68 of mucilage, sugar, and digestible fibre a fair average result in linseed cake?—*A.* It is; the whole analysis represents fairly the composition of good linseed-cake—the approximate composition.

*Q.* In fact, I have been throwing the decimals together, and it gives you a proportion out of the 100 of 66·42 of flesh-giving, nutritious elements?—*A.* That is so.

*Q.* Now, I think on the 16th of June, 1871, you made an examination of a sample of pure linseed-cake, which is warranted pure, for Messrs. Ayre Brothers; this is an analysis of Diamond K., which you have heard of this morning, the purest linseed known in commerce. You made that analysis (handing a paper to the witness)?—*A.* Yes.

*Q.* That was sent to you by Ayre Brothers?—*A.* Yes.

*Q.* There you found moisture 10·88; albuminous compounds, flesh-forming matters, 29·12; mucilage, sugar and digestible fibre, 27·43; woody fibre, 12·53; mineral matter and ash, 7·58; = 100. Containing nitrogen, 4·66?—*A.* Yes.

*Q.* I find there that the pure Diamond K. has 69·01, and the linseed-cake that Mr. Wells' cattle are said to have been injured by has 66·42?—*A.* That is so.

*Q.* The pure linseed-cake being sold at from 11*l.* to 12*l.* per ton in the market, and the other at 10*l.*?—*A.* Yes; and that clearly shows that —

*Q.* I will trouble you not to make a speech. Is it worse or better than the present?—*A.* It is described as pure.

*Mr. Justice BLACKBURN:* Will you tell me shortly, is the analysis made in 1871 an analysis superior or inferior to the present?—*A.* The analysis which I made in 1871 is an analysis of a pure linseed-cake, and practically the analysis of the pure cake shows neither worse nor better than the analysis of the mixed cake; showing, what I mentioned in my Report, that you cannot draw an inference from the mere approximate results of an analysis.

*Mr. SEYMOUR:* Then you are no use, practically, to us in this investigation?—*A.* Well, that you will find out for yourself; it is a matter to be decided with reference to the appearance of these animals, and the history of the case, without going into these microscopical matters.

*Q.* If I get the same proportion of nutritious matter in the one as in the other, is one more than the other injurious to life?—*A.* I will answer your question in this way: You may get the same amount of oil in an analysis of olive-oil as in an analysis of castor-oil; but the effect, as you know, would be totally different. In olive-oil, as in castor-oil, this approximate analysis gives merely the quantity of oil, albuminous compounds, and so on.

*Q.* But I understand you to say that the oil from sesamé-cake, for instance, is quite as wholesome as the oil from linseed-cake?—*A.* I believe so.



Q. As to this, you say: "I find it is made from clean linseed and nothing else, and in my opinion is a first-class pure linseed-cake"?—A. Yes.

Q. Now I want to call your attention to another analysis of yours. I think you made an analysis for Messrs. Barclay and Company?—A. It is very likely.

Q. In May last (handing a paper to the witness)?—A. Yes.

Mr. Justice BLACKBURN: Did you make that analysis in May last?—A. Not this; no, I did not make any for Messrs. Barclay and Company. This is an analysis of a cake.

Mr. SEYMOUR: That is what I asked—a linseed-cake?—A. It was not a linseed cake.

Mr. Justice BLACKBURN: Is it yours at all?

The WITNESS: There are two analyses; there is one of the pure linseed-cake, which is taken from some published results, as I take it. I did not analyse that for Messrs. Barclay.

Mr. SEYMOUR: Taken from some published results—but did you take it?—

A. No.

Q. Then I will put it in another form. Suppose you were to meet with an analysis containing oil, 10·88; albuminous compounds, 26·25; mucilage, sugar and digestible fibre, 23·80; making altogether 50·05 in the 100: would that be a pure linseed cake—would that be such a proportion as you would say would be consistent with a pure good-feeding linseed-cake?—A. Yes; about that.

Q. I think there was a sample sent up to you by Mr. Knowles, of Hull, which I want to ask you a question about (handing a document to the witness)?

Mr. Justice BLACKBURN: When was this?

The WITNESS: Last month, July the 24th.

Mr. SEYMOUR: Did you on that day receive from Mr. Knowles, of Hull, a sample of linseed-cake?—A. Yes, I did.

Q. And I think you found it to contain oil 12·16, albuminous compounds 29·68, mucilage, sugar, and digestible fibre 26·24, making all together 68·08?—A. Yes.

Q. And I think you pronounce that to be——?—A. A pure cake.

Q. You say you found it a superior, genuine linseed-cake, made from clean linseed and nothing else?—A. Yes.

Q. This is a sample of pure seed, I think (handing a bottle to the witness)?—A. Yes; that is a fairly clean seed.

Mr. Justice BLACKBURN: What are these? Are they the seeds or the cake?

Mr. SEYMOUR: I have shown him a specimen 'of linseed, my Lord, and I will prove by-and-by that the cake was made out of it. (To the witness.) What is this (handing a bottle to the witness)?—A. This is sesamé.

Mr. Justice BLACKBURN: Sesamé-cake or sesamé-seed?—A. Sesamé-cake.

Mr. ROBERTS: Sample A is clean linseed, and sample B is the other.

Mr. SEYMOUR: Now, just tell me, if you please, does that appear to you to be a fair specimen of linseed (pointing to sample A)?—A. Yes, it is fairly clean.

Q. Does not that contain, visible to the eye, a number of those seeds that you have mentioned?—A. Yes; I recognise several already, amongst them, my friend the drunken darnel.

Q. This is a bottle containing a sample of sesamé-cake (handing the same to the witness). Did you find any of that in the analysis you made the other day for Mr. Knowles?—No.

Q. There is a favourite expression of modern times—"would you be surprised to find" that 20 per cent. of it was of that cake?—A. Not at all.

Q. You mean you would not be surprised?—A. I would not be surprised.

Q. Therefore I may take it you would certify a cake to be nothing else than

pure linseed, although it contained 20 per cent of sesamé-cake?—*A.* Oh, yes; that would be quite so, because it is extremely difficult to find out, when this cake is so finely crushed, what it is.

*Q.* But do not let me shrink from the direct question which I meant to put; even if it is found, knowing what a good, nutritious thing sesamé-cake is, do you alter the opinion you have given, that that is a good, genuine linseed-cake, supposing I prove to you that there was 20 per cent. of sesamé-cake in what you analysed, would you say that it was not?—*A.* Certainly, if I found that I had made a mistake, I would say it was not. I would not say it was a genuine linseed cake if I had not failed to detect the sesamé-cake.

*Q.* But with 80 per cent. of pure linseed, and 20 per cent. of sesamé, do you mean to say that that would not be a good, pure cake?—*A.* It might be.

*Q.* A good feeding and perfectly wholesome cake?—*A.* Yes, sesamé-cake, if it is in good condition, is a good feeding cake.

*Q.* Will you look at the seed if you please?—*A.* This is a specimen of sesamé-seed and sesamé-cake.

*Q.* If it is a good specimen of sesamé-cake and carefully imported into this country, you do not say it is an improper food for cattle?—*A.* Certainly not.

*Q.* Now look at that linseed (handing another specimen marked C). Just take bottle A and bottle C, and tell me if there is any difference between them, and if so, which you think the cleaner of the two?—*A.* Well, I could not form an opinion by looking at it roughly.

*Q.* As far as you can judge from the eye?—*A.* I should say *this*, if any thing, would be the cleaner (pointing to one of the specimens).

Mr. SEYMOUR: Then that is what we made this cake of.

Mr. Justice BLACKBURN: That we shall hear by-and-by, when your witnesses come and are cross-examined.

*Re-examined by Mr. FIELD.*

*Q.* Are you able to judge without a microscopical examination accurately with reference to the comparison of the two bottles?—*A.* No; merely judging roughly, it appeared to me a cleaner seed.

*Q.* You told my friend that sesamé in itself is a good feeding cake?—*A.* If it is in good condition it is.

*Q.* Under what conditions does sesamé become injurious?—*A.* When it is kept in a damp place or an ill-ventilated place, or if it is shipped in a wet condition and heats on the passage, then it may become mouldy, or otherwise damaged and unfit for food.

*Q.* And if ground up and mixed with other linseed-cake, would it affect the whole of the linseed-cake?—*A.* It would.

*Q.* My friend asked you whether you would be surprised if that cake which you analysed and said was genuine contained 20 per cent. of sesamé. Should you, if you had found 20 per cent. of sesamé have certified it as a genuine cake?—*A.* It is very possible I might have missed it.

*Q.* But I say had you found it?—*A.* If I had found it certainly not.

*Q.* In this very cake that you are now speaking of were you able to find the sesamé?—*A.* No, it is impossible to find sesamé if it is so finely ground.

*Q.* What is the effect of your analysis—does that show you what the cake is composed of, as distinguished by seeds from seeds, or merely the feeding or other properties of what there is in the cake?—*A.* It may show the composition of a very poisonous material, as well as a feeding material. You find the same approximate constituents of albumen or oil in the most poisonous as well as in the most nutritious seeds.

*Q.* Therefore by itself is the chemical analysis a test of purity or not?—*A.* No, it is not.

Q. In order to form a judgment you would submit it to a microscopical examination?—A. Exactly so.

Q. Did this cake that you examined disclose a different proportion of mucilage?—No, it did not.

Q. Did you compare the proportion of mucilage in this cake, together with some pure cake by the same operation?—A. I did.

Q. And was there a great difference between the two?—A. A great difference. Pure linseed becomes very mucilaginous, and this cake did not become so.

Q. Do you see any reason to alter the judgment which you came to on the 2nd of March, as stated in the report you made to the Society?—A. I see no reason for altering it, and it is confirmed by many cases that we have had.

Q. You have heard in evidence what happened to these beasts?—A. Yes.

Q. In your judgment might that be caused by giving them cake of this description?—A. Oh, it might be caused by that.

Mr. SEYMOUR: You say the symptoms from which these beasts were suffering might be what?—A. I replied to the question.

Q. What did you say?—A. This cake might have caused the death of the animals.

Q. Was there anything in their symptoms which might not be referable to other causes, so far as the symptoms were concerned, than the taking of deleterious cake?—A. Certainly, there might be other causes.

Q. Sudden change of food under certain circumstances, especially in the case of cattle who had been taken off grass and had been stall-fed—is not that frequently attended by distension, distress, moaning, shivering, and the other symptoms we have heard of here?—A. Well, perhaps, you would better address those questions to Professor Simonds who is a veterinary surgeon—I am not.

Q. Are you the author of a paper or an article in the 'Journal of the Royal Agricultural Society of England' of this year, from which I will just read you a passage, I see your name is to it:—"In a report on the samples of feeding-cakes, submitted to me during the past twelvemonths, I should not omit to state that five or six cases have been reported to me, in which decorticated cotton-cake was alleged to have caused the death of sheep and lambs, and to have seriously injured the health of others. The examination, however, of the cotton-cakes, which were supposed to have done the mischief, showed that they did not contain any poisonous ingredient, and that several of the specimens were cakes of the finest quality ever submitted to me for examination. These cakes contained over 40 per cent. of albuminous compounds, and as they were as fresh and palatable as a nut, I have little doubt that the animals who suffered in health partook too freely of them, and were unable properly to digest the large proportion of nitrogenous compounds which first quality decorticated cotton-cake contains. In point of fact, good decorticated cotton-cake is too rich in nitrogenous matters to suit well by itself the constitution of herbivorous animals, and I would, therefore, strongly recommend its being mixed with Indian corn or a similar starchy food, comparatively poor in nitrogenous matters." It may be, therefore, that symptoms which you find, and which are supposed to indicate a poisonous ingredient in a cake, may be referable to the fact that the cattle have too greedily eaten of a pure cake?—A. It is like eating too much beef-steak.

Mr. JOHN THOMAS WAY sworn: *examined by Mr. MELLOR.*

Q. Are you a Fellow of the Chemical Society?—A. Yes.

Q. Were you professor of chemistry for some time to the Agricultural College of Cirencester?—A. Yes, I was, for some years.

Q. And also consulting chemist to the Royal Agricultural Society?—I was for eight or nine years.

Q. Did you assist Professor Voelcker in making an analysis on the 16th of July?—A. I made with him an examination of two samples of cake on the 16th of July.

Q. What was the examination you made?—A. We made a few simple tests as to the character of the cakes, and also some microscopical, or rather optical examinations—examinations under a strong lens.

Q. Did you make any notes yourself?—A. I did not make any notes.

Q. Have you heard Dr. Voelcker's account of it to-day in the witness-box?—A. I have.

Q. Speaking from memory is that correct?—I believe so. There are some points which Dr. Voelcker has spoken to which I should rather not say anything about, simply because my botanical knowledge is not very great, and I do not profess to give any opinion upon that. There were some things which I was competent to detect in the analysis, others were pointed out to me by Dr. Voelcker, but which I do not profess to know. Simply, I could see that there were a good many seeds which should not be present in a genuine linseed-cake.

Q. Tell us what you observed yourself?—A. I saw particles of bran, of husks, and of what I considered to be oats and barley, and a great variety of seeds which I know to be seeds of weeds, but which I could not particularly specify.

Q. Do you know anything of the properties of the seeds of weeds you saw?—A. I do not.

Q. Is there anything else; can you tell me anything that you noticed yourself, and which you knew?—No.

Q. Either the name or what it was?—A. No.

Q. Nothing else?—A. No, nothing else.

Q. Will you tell me the result of what you saw?—A. I think you must take generally from me that, so far as my knowledge goes, and having formerly examined very many samples of pure linseed-cake, I considered this to be an inferior cake. That is the general result of my examination—cake made from dirty seed or from mixed materials other than linseed. Perhaps you will allow me to say that at the time when I was the chemist of the Agricultural Society it was not usual to find any great number of adulterated cakes, and therefore my experience deals more with good cakes.

*Cross-examined by Mr. SEYMOUR.*

Q. Just one question or two. I suppose in the hay that the cattle eat there is a certain proportion of what you call weeds?—A. No doubt.

Q. What is a weed? Do you agree with the poet that it is a flower out of place. I think that is the definition we have had of it. Just take that bottle and look at that sample of seed (hands a bottle marked C to the witness)?—A. Yes.

Q. Can you detect any of those foreign seeds in that?—A. That is a tolerably pure specimen of seed, I should say.

Q. Do you find there several of those vegetables that we have heard mentioned?—A. I can see seeds other than linseed, but not in very great numbers.

*Mr. RICHARD V. TUSON sworn: examined by Mr. FIELD.*

Q. What are you?—A. I am Professor of Chemistry at the Royal Veterinary College in London.

Q. On the 19th of July did Dr. Voelcker give you a parcel containing some feeding cake?—A. He sent me a parcel by the Parcels Delivery Company.

Mr. Justice BLACKBURN: Whom did you receive that from?—A. From Dr. Voelcker, my Lord.

Dr. VOELCKER was here recalled, and proved that the parcel contained samples of the broken cake from Booth Ferry, and of the cake from Airmyn Pastures.

*Examination of Mr. TUSON continued by Mr. FIELD.*

Q. Have you submitted both samples to chemical analysis?—A. I have.

Q. Do you find that they agree?—A. They agree.

Q. Have you got a copy that you can hand to the Court?—A. I have my notes here.

Q. First of all take the fragments, and give us the chemical analysis of them?—A. It contains, "moisture, 7.75 per cent.; oil, 12.67; mucilage, etc., 27.64; then flesh formers, albumenoid bodies, 33.48."

Q. Containing how much nitrogen?—A. I have not got that.

Mr. Justice BLACKBURN: Here there is a mark showing that. Do not your notes show it?—A. No, my Lord, it is in my report.

Mr. SEYMOUR: What is the amount?

Mr. FIELD: 5.4.

The WITNESS: Yes. "Fibre, 10.23; ash, 8.23."

Q. Now give us the analysis of the whole cake?—A. "Moisture, 7.47; oil, 12.31; mucilage, etc., 27.71; albumenoids, 32.80; fibre, 10.88; ash, 8.83. Total, 100."

Q. How much nitrogen in the albumenoids?—A. It is in my report. It is not here in my notes.

Mr. SEYMOUR: Will you tell me?

Mr. FIELD: 5.29. (To the Witness.) Does this analysis enable you to form any judgment as to whether they were pure cakes or otherwise, or whether they contained other elements?—A. Not at all.

Q. You have heard what Professor Voelcker says as to that; do you agree with him as to that?—A. Quite so—entirely.

Q. What is the next step in finding out what you want to know as to the actual composition of the cake?—A. To make a microscopic examination of the cake.

Q. Did you do that?—A. I did.

Q. Tell me what you found on microscopical examination?—A. I found that the cake chiefly consisted of linseed, bran, and sesamé.

Mr. Justice BLACKBURN: Are you speaking now of both samples; is there any difference between them?—A. Practically no difference. Then I found dodder seeds, millet, wheat, barley (I am now referring to husks, not to whole seeds).

Q. Does that observation apply to all—am I to change the dodder, millet, wheat, and all into husks?—A. No. Those were the whole seeds—the dodder, millet, and charlock.

Q. Charlock! you did not mention that before. Then it is the wheat and barley that were husks?—A. Yes, my Lord, with some other husks—oat, rice, and cotton seed husks, and the husks of the cocoa or palm nut. I cannot distinguish one from the other. Besides these I discovered other seeds which I could not name until after consultation with Dr. Voelcker; and these other seeds, or many of them, were pointed out to be as follows.

Mr. SEYMOUR: By whom?—A. By Dr. Voelcker.

Mr. FIELD: Were they the same as Dr. Voelcker has mentioned?—A. Yes.

Q. You saw the seeds there, but you could not give them their names?—  
A. Yes, I saw them, but I could not give their names.

Q. You said husks of wheat and husks of barley. Did you also find one or two grains of wheat?—A. One or two fragments.

Q. What sort of wheat were they?—A. It seemed to be like tail wheat.

Q. Have you got your report there that you made at the time?—A. These manuscript notes are those I actually made at the time of the observations.

Q. Did you make a report at the same time to the Society?—A. Yes.

Q. Just refresh your memory with that, and just read the first three or four lines, and tell me besides those you have mentioned whether you found anything else?—A. I have read the first three or four lines.

Q. "Husks of cocoa or palm-nut,"—what after that?—A. One or two pieces of mouldy wheat.

Mr. Justice BLACKBURN: See if you have got it in your note?—A. Yes, I have it.

Q. Read a portion of your notes?—A. I only just made memoranda, "mouldy wheat" as one of the things I found.

Q. Can you tell us, either from your notes or from your recollection, what quantity?—A. I can form no accurate judgment of the quantity; there is no means of estimating it.

Q. But you can tell us what quantity of mouldy wheat you actually saw. Of course you cannot say how much there is altogether, but what you actually saw?—A. I found a grain or two here and there.

Q. In seeds?—A. It seemed like fragments of wheat compacted together, or agglutinated together, with a little mould round them.

Mr. FIELD: Was what you have told us now the result of optical examination?—A. Yes.

Q. Did you then submit the samples to microscopic examination?—  
A. Yes.

Q. Did you find under the microscope the same things that you could see with the eye.—A. Yes.

Q. Did you find anything else?—A. By the microscope I discovered the sesamé and the bran.

Mr. Justice BLACKBURN: Do I understand that you did not see the sesamé and bran with the naked eye?—A. The bran I did, but it was confirmed by microscopic examination.

Q. But you did not see the sesamé?—No; it was in such a very fine state of division that one could not with the naked eye, or even with a pocket lens, detect it.

Mr. FIELD: Now, tell me from your judgment of the cake what should you say it was prepared from?—A. I should say it was prepared from dirty or unscreened linseed.

Q. Anything else besides?—A. Or it might have been that some sweepings of warehouses may have been added to it.

Q. In your judgment was that fit food for cattle?—A. I should say not.

Q. Have you heard in Court to-day the symptoms under which the cattle of Mr. Wells laboured after eating the cake?—A. I have.

Mr. SEYMOUR: He is not an expert, and I object to this.

The WITNESS: I prefer to answer the question direct, and I was going to add that I have no special knowledge of the symptoms.

*Cross-examined by Mr. SEYMOUR.*

Q. Will you read the memorandum from your note with regard to the wheat?—A. Do you mean with regard to the mouldy wheat?

Mr. Justice BLACKBURN: Read your actual note as you took it down?—A. I have simply got here “wheat,” and after that “mouldy wheat.”

Mr. SEYMOUR: About the quantity?—A. I cannot speak of the quantity.

Q. Then you have no memorandum made of the quantity?—A. Not of the quantity; but I have a distinct recollection, because it is only a day or two ago that I made the examination.

Q. When you say “fragments of wheat” do you mean fragments of grains of wheat?—A. Fragments of grains.

Q. How many fragments of how many grains do you think you saw?—A. I should say in about an ounce of the cake I saw perhaps seven or eight of those fragments.

Q. With the naked eye or the microscope?—A. Partly by the naked eye, and partly by the microscope.

Mr. Justice BLACKBURN: When you mention those fragments are you speaking of mouldy wheat?—A. Not now, my Lord.

Mr. SEYMOUR: I asked you with regard to the mouldy wheat?—A. I found a very much smaller number of pieces of mouldy wheat.

Q. You found seven grains partly with the naked eye, and partly with the microscope, that were not mouldy?—A. Yes.

Q. And you found still fewer that you say might have been mouldy?—A. Yes, I examined them and found that they were mouldy.

Q. You found that they were mouldy under the microscope?—A. Under the microscope.

Q. But I suppose a particle of mould which would surround such a small particle of microscopically discovered wheat might be accounted for by weather, or even by sending up from the country, and a thousand possible ways?—A. It might be accounted for in a thousand ways.

Q. Atmospheric changes, sending up by train in guano bags, and so on. Are you able to make any estimate of the proportion of husks found in the general body of the samples, leaving out the bran; for I do not dispute that there was bran in this cake, taking other things—wheat husks, and rice husks?—A. I could not form a notion.

Q. Were you able at all to arrive at anything like a fraction of the proportion?—A. I could not name the number.

Q. Or form an estimate?—A. No.

Q. Have you got the specimens here? Because you speak of the optical effect?—A. I have got the specimens of the cake received.

Mr. Justice BLACKBURN: You say your eye discovered certain things?—A. I could see the things that were in it.

Q. I mean that which your eye saw?—A. There is one sample.

Q. I suppose you would agree with Professor Voelcker that the dodder, millet, and charlock, in greater or less proportions, may be found in pure linseed?—A. Yes, that is to say, unscreened linseed.

*Re-examined by Mr. FIELD.*

Q. You found this in the condition of seeds. What you found or saw there were certain seeds or parts of seeds?—A. Yes.

Q. And there may be more crushed up together with the rest, which you would not be able to see?—A. There may be fragments that would not be detected except by the microscope.

Q. And crushed up with the cake they would not be seen?—A. Not by the naked eye.

Mr. FIELD: I had better mark this “D.”

Mr. SEYMOUR: Will you look at this specimen of the cake (handing some

to the witness), and tell me whether you do not discover some of the husks of wheat there?—*A.* I would not pretend to say.

*Q.* But I mean similar to what you saw?—*A.* Oh, dear no.

*Q.* Are there husks?—*A.* I see here and there seeds which are certainly not linseed; what they are I could not say without a patient and quiet analysis.

*Mr. Justice BLACKBURN:* What sample is that?

*Mr. SEYMOUR:* The sample I handed to the witness was a piece that was broken off by Professor Voelcker.

*Mr. FIELD:* Put "E" upon it (to the witness). Now this has been shown to you, and you say it does not accord at all with the cake that you saw?—*A.* Oh, dear no.

Professor THOMAS FAIRLEY sworn: *examined by Mr. MELLOR.*

*Q.* Are you consulting chemist of the Yorkshire Agricultural Society?—*A.* I am.

*Q.* And on the 19th of February did you receive from Mr. Wells a sample of cake for analysis?—*A.* I did.

*Q.* Did he afterwards give you any other samples?—*A.* He afterwards gave me other three at different times.

*Mr. Justice BLACKBURN:* Can you give us the dates of the other three?—*A.* The second sample was in the first week of March. I do not remember the date. The third sample on the 19th July, and the fourth sample on the 1st of August.

*Mr. MELLOR:* Did you make a chemical analysis of each sample as you received it?—*A.* I did.

[Some discussion here arose as to the identity of the samples.]

*Mr. MELLOR:* Now as to the chemical analysis of the first sample?—*A.* From Booth Ferry, No. 1.

*Mr. Justice BLACKBURN:* This is the analysis, as I understand it, of the sample which was given him on the 19th of February, which was a sample of the stuff which was broken up at Booth Ferry. That is how I understand it.

The WITNESS :

Water	..	..	..	..	..	..	..	..	..	..	12.21
Oil	..	..	..	..	..	..	..	..	..	..	12.10
Ash (mineral matter)	..	..	..	..	..	..	..	..	..	..	8.86
Albumenoids	..	..	..	..	..	..	..	..	..	..	23.00
Woody fibre, or indigestible fibre	..	..	..	..	..	..	..	..	..	..	18.80
Gum, mucilage, and starch	..	..	..	..	..	..	..	..	..	..	25.03

100.00

*Mr. MELLOR:* Were you able to come to any conclusion from the chemical analysis only as to the purity of the cake or otherwise?—*A.* No positive conclusion.

*Mr. SEYMOUR:* How much nitrogen did you find in the albumen?—*A.* 3.68.

*Mr. MELLOR:* Did you afterwards make a microscopic examination of the same sample?—*A.* I did.

*Q.* Will you tell us the result of that?—*A.* I can tell you them from memory. I have got no notes of the microscopic examination, I have got them in the report that I made at the time.

*Q.* Just look at this (handing a document to the witness). Is that the report that you made at the time?—*A.* That is the report I made at the time.



Q. Looking at that, will you tell us the result of the microscopic examination?—The results show that this is a dirty linseed-cake; besides various seeds, it contains some quantity of dirt and foreign matter, agglutinated in small hard lumps throughout the cake, probably refuse from the warehouses, derived from the various oil-producing materials. I was not able to say more positively what they were.

The ASSOCIATE read the Report, which was as follows:—

*Report on Analysis of Linseed-cake, received from John Wells, Esq., J.P., Booth Ferry House, Howden, March, 1872.*

A careful chemical analysis does not show the presence in the cake of any known poison, mineral or organic. The amount of ash is above the average good linseed-cake. The microscopic examination shows that this is a dirty linseed-cake." Besides various seeds it contains some quantity of dirt and foreign matter, agglutinated in small hard lumps throughout the cake, probably refuse from the warehouses, derived from various oil-producing materials. I send a packet containing the following seeds, which I have picked out—*Polygonum*, *Convolvulus*, *Chenopodium atriplex*, *Sinapis arvensis* charlock, *Sinapis nigra*, *Carduus arvensis* or field thistle, clover, and grass seeds, particles of rice, oat, and wheat grains, chaff and bran, and also bits of hair, straw, and stems. Much of the linseed in the cake is whole and not crushed, and the cake contains much starchy and other refuse matter. Amongst these there may be injurious seeds or substances, whose presence will be best shown by their effects on healthy animals. The cake is inferior, and not best linseed-cake.

(Signed)

THOMAS FAIRLEY.

27, Commercial-street, Leeds,  
March, 6th, 1872.

Mr. Justice BLACKBURN: Are you acquainted with the properties of these seeds?—A. I have no great knowledge of the effects of poison. I speak of it only as detected by chemical means.

Mr. MELLOR: Do you know anything of these seeds mentioned in the report?—A. I know them when I see them. I have no great knowledge of their properties or effects upon animals.

Q. Now as to the next sample; did you make a chemical analysis of that?

A. Yes.

Q. And also a microscopical examination?—A. Yes.

Q. These two samples together—one the sample from which the cake was bought, and the other from Airmyn Pasture. At that time you had the two samples together, had you not?—A. No, the sample I had in March was a piece which I myself broke off from the sample cake which Mr. Wells told me he had got from the dealers. It was called a sample cake to me.

Q. Is that the Report you made at the time?

Mr. Justice BLACKBURN: Again I wish to say how I understand it, in order that I may be set right if I go wrong. This, I understand, would be an analysis of the sample cake from which Mr. Wells originally bought?

Mr. FIELD: Yes, my Lord, that is so.

Mr. MELLOR: Is that the Report you made at the time (handing the same to the witness)?—A. That is the Report.

Mr. Justice BLACKBURN: Hand that in.

The ASSOCIATE read the Report, which was as follows—:

*Report on Analysis of two samples of Linseed-cake, received from  
J. Wells, Esq., Booth Ferry House, Howden.*

I have named that received first 'bulk,' and the other 'sample.' They contain:—

	Bulk.	Sample.
Moisture .. .. .	12·21	11·49
Oil .. .. .	12·10	12·16
* Albumenoids .. .. .	23·00	23·38
Woody fibre .. .. .	18·80	19·80
† Digestible fibre, starch, &c.	25·03	24·22
Ash .. .. .	8·86	8·50
	<hr/> 100·00	<hr/> 100·00
* Containing nitrogen .. .. .	3·68	3·74
Equal to ammonia .. .. .	4·47	4·56
† Estimated by difference.		

The sample contains much starchy matter, and if anything less of weed-seeds than the other. The chemical analysis can scarcely be said to show any practical difference. I think bran is the chief adulterant.

(Signed) THOMAS FAIRLEY.

27, Commercial-street, Leeds,  
March 27th, 1872.

Mr. MELLOR: No. 1 seems to be the same thing as that of the 19th of February?—A. Yes.

Q. You found no substantial difference?

Mr. Justice BLACKBURN: You do not read it quite as the copy before me is but I think as far as I can see, there is substantially no very great difference between the bulk and the sample.

The WITNESS: There is not, but there is more nitrogen in the sample, and a degree less of digestible fibre; so that the bulk is shown to be better than the sample.

Mr. Justice BLACKBURN: You may take it it is substantially the same.

Mr. SEYMOUR: If anything the bulk is better than the sample.

Mr. Justice BLACKBURN: At all events they substantially agree.

Mr. MELLOR: Did you make an analysis of the third sample?—A. Yes.

Q. Did you make a microscopic examination of the one that has just been alluded to?—A. I did; the sample verified the fact that the same seeds were present as I found in No. 1.

Q. The same in both samples as in No. 1?—A. Yes, and also in that Report I mention that I think bran is present in the same quantity.

Mr. SEYMOUR: In what quantity?

The WITNESS: That "bran is the chief adulterant," I think are the exact words that are used.

Mr. Justice BLACKBURN: Yes, that is the phrase used.

Mr. MELLOR: Are these your Reports of July and August (handing a document to the witness)?—A. They are.

Q. The July cake was the Airmyn cake. Did you make an examination of that?—A. Yes, and the results are practically the same.

The ASSOCIATE read the Report which was as follows:—

*Report on Analysis of sample of Linseed-cake, received from John Wells, Esq., Booth Ferry House, Howden, July 19th, 1872 (No. 3).*

The cake contains:—

Moisture .. .. .	12·05
Oil .. .. .	12·12
* Albumenoids .. .. .	23·13
Indigestible fibre .. .. .	18·75
Digestible fibre, gum, mucilage, starch, &c. .. .. .	25·30
Ash (mineral matter) .. .. .	8·65
	100·00

\* Containing nitrogen 3·7 per cent.

The microscopic examination confirms the result of these numbers, that this cake is identical in composition with the others which I have analysed (Nos. 1 and 2)—the portion of crushed cake sent by rail, and the portion of the dealer's sample cake described in my Report of March 27th.

(Signed) THOMAS FAIRLEY.

27, Commercial-street, Leeds,  
3rd August, 1872.

Mr. MELLOR: We now put in the August sample.  
The ASSOCIATE read the following Report:

*Report on Analysis of sample of Linseed-cake, received from John Wells, Esq., Booth Ferry House, Howden, August 1st, 1872.*

The sample was an entire cake, labelled at the opposite corners with the initials I.W. I.G. I have not found any known poison in the cake. The following is the result of the chemical analysis:—

	No. 4.
Moisture .. .. .	12·05
Oil .. .. .	12·12
* Albumenoids .. .. .	22·75
Digestible fibre, gum, mucilage, starch, &c. .. .. .	25·74
Indigestible fibre .. .. .	18·70
Ash (mineral matter) .. .. .	8·64
	100·00

\* Containing nitrogen 3·64 per cent.

The ash contains 2·5 per cent. of sand, and about 4 per cent. of phosphoric acid, reckoned as tribasic phosphate of lime. The numbers coincide with those of the other three samples analysed. The microscopic examination shows the same impurities; the whole four samples furnished to me by Mr. Wells are therefore of the same cake: they are,—No. 1. Crushed cake from same lot as had been given to the cattle (sent by rail February, 1872). No. 2. Sample cake; a portion broken off by me in Mr. Wells' presence from the maker's sample cake, March, 1872. No. 3. Portion of cake, not crushed, from a different farm from No. 1, received July 19th, 1872. No. 4. Entire cake labelled

I.W.  
I.G. as described above, received August 1st, 1872.

(Signed) THOMAS FAIRLEY.

27, Commercial Street, Leeds.  
August 5th, 1872.

Mr. Justice BLACKBURN: Does he say at the bottom that it is identically the same as the other or not? Because if he winds up by saying that, that is enough.

Mr. FIELD: The microscopic examination is the important part.

Mr. Justice BLACKBURN: It comes then to this result, that he says all these samples are the same.

Mr. MELLOR: Was there anything that you omitted to mention in the Report?—A. I omitted to mention that I had observed, a day or two before I wrote the report, that the uncrushed seeds that I mentioned are lying in all positions; instead of lying in a uniformly parallel state as they generally do in *bonâ fide* linseed cakes, they were at all angles and positions.

Mr. Justice BLACKBURN: When was this that you noticed this for the first time, in August or before?—A. I did not specially notice it before; I did not notice that it had any special bearing on the question.

Q. When did you see or observe the fact that you are mentioning that the seeds were lying in this way; when had you first noticed that?—A. I noticed it, as far as the note is concerned, a day or two before I wrote that.

Q. Describe what it was that you did notice again.—A. The uncrushed seeds lay in all positions, at all angles with each other, instead of the flat pieces of the seeds being parallel with each other, as they are from the effect of pressure.

Q. What is your inference from that?—A. That the seeds have been put into the cake uncrushed, and that the pressure used in making the cake was used to make the cake, and not to express the oil from the cake—to make it cohere; in other words, simply that it is a made-up cake.

Mr. MELLOR: What sort of a cake was this—a hard cake or a tender cake?—A. A tender cake, easily broken.

Mr. SEYMOUR: Have you got a bit of it here?—A. I have got the whole four samples, what I had left.

*Cross-examined by Mr. SEYMOUR.*

Q. Am I to understand from you that your suggestion is that this cake which went in the quantities that we have heard to Booth Ferry and Market Weighton, and so on, was cake manufactured as cake, and not cake produced in the expressing of linseed oil?—A. That is my inference.

Q. That is what you want us to infer.—A. Yes.

Q. Have you entered into a calculation of the profit that would leave to Mr. Kidd; have you at all calculated what profit it would be to do that sort of business?—A. I have made no calculation whatever of that sort.

Q. Now, allow me to ask you this; you say that there was a greater quantity of ash than the quantity of ash that you would expect in a good linseed cake.

Mr. Justice BLACKBURN: A greater quantity in which?

Mr. SEYMOUR: A greater quantity in the bulk and sample which he has just reported upon, a greater quantity than there ought to be.

Mr. Justice BLACKBURN: I did not catch that, but no doubt you are right.

Mr. SEYMOUR: He says so in the report. (To the Witness.) The quantity that you gave was 8.86. Do you mean to tell me that perfectly pure cake—I put to you a perfectly pure linseed cake—does not give you quite as much ash?—A. I never found it do so.

Q. Does it not give as high as 8?—A. I have never found it higher than 6. I am told that sometimes it is as high as 7, but I have never found it higher than 6 myself.

Q. Professor Voelcker to-day has given us 7.58 in a specimen of pure linseed cake.—A. I only speak from my own experience.

Q. You do not dispute that it may be so.—A. It may be so. I only speak from my own experience.

Q. I find you giving a proportion of woody fibre larger than either of the other chemists. Did you adopt the same mode of analysis?—A. I do not know what mode they did adopt. I adopted the usual mode. I believe it would be the same, but I do not know for certain. My report is given entirely independent of anything that they said.

Q. What is the highest proportion of woody fibre that you will allow in a fairly good sample of linseed cake. Does it not sometimes go up to the extent of 16 or 17?—A. It might go as high as 20 perhaps, but I cannot say.

Q. In your case it goes to 18?—A. Yes.

*Re-examined by Mr. FIELD.*

Q. What is the highest you have ever met with yourself?—A. About 20, I think.

Mr. SEYMOUR: My friend, Mr. Cave, has called my attention to the fact that the indigestible or woody fibre includes the ash?—A. It includes some ash—the ash that remains with it.

Mr. SEYMOUR: Then you say that you find in good linseed 20 per cent. of woody fibre?—A. I would not call it good linseed as high as that.

Q. It might be moderately good?—A. Yes.

---

SECOND DAY.

Mr. JONATHAN MIDGLEY, sworn: *examined by Mr. MELLOR.*

Q. Are you a member of the Royal College of Veterinary Surgeons in practice at Goole?—A. Yes.

Q. On the 16th of February were you sent for to Booth Ferry, to see Mr. Wells' cattle?—A. Yes.

Q. Did you examine the feeding beasts on your arrival, and also the cows?—A. Yes.

Q. In what state did you find them?—A. Well, some of them were very much tympanated—blown up, with shivering of the limbs,—and moaning heavily. Some of the feeding beasts were worse than the cows.

Q. Was one cow dead when you got there?—A. Yes.

Q. Did you make a *post mortem* examination of that cow?—A. Yes, the same day.

Q. Did you take out the stomach, liver, lungs, heart, and kidneys, and place them in a box for the purpose of being sent to Professor Simonds?—A. Yes, all the intestines.

Q. At the time you did this did you notice any appearance of organic disease?—A. No, there was no appearance of any disease to be seen.

Q. Did you make inquiries of Tutty and the other man as to how the animals had been fed at the time?—A. I did.

Q. Besides that what did you do to the dead cow, and what did you do to the living animals?—A. I gave the worst some medicine, and the others I let be.

Q. What medicine did you give them?—A. I gave linseed oil.

Q. To how many did you give linseed oil?—A. Four or five.

Q. Did you give any direction with regard to the further treatment of them?—A. I gave orders that they were not to have any more cake.

Q. Anything else?—A. No.

Q. Speaking as a veterinary surgeon, what did you come to the conclusion was the matter?—A. Well, I considered they had had something to disarrange the stomach. Something that had not agreed with the animals.

Q. In your opinion could a feed of 7 lbs. of good linseed-cake have produced the effect you found?—A. No.

Q. You heard the mode in which they were fed. Was there anything in the mode in which they were fed, apart from the quality of the cake which was given them, which could have produced what you saw, in your opinion?—A. No.

Q. You have heard the mode described in which the mangold wurzel was given to the cows. Was there anything either in the giving of the mangold wurzel, either in the manner or in the mangold wurzel itself, which in your opinion could produce what you found?—A. No.

*Cross-examined by Mr. SEYMOUR.*

Q. You found the beasts that you saw suffering more or less from distension and appearing distressed?—A. Yes.

Q. Were those the symptoms of what is known in veterinary surgery as hoven or tympanitis? I believe it is known by both names, but it is also spoken of as acute tympanitis?—A. It is.

Q. I believe the words are exchangeable—the one means the other?—A. Yes.

Q. And would that properly describe what you saw?—A. Yes.

Q. Is not hoven very frequently produced by animals eating a very hearty meal of clover or potatoes, or anything else that they may choose to fancy?—A. Not at that time of year.

Q. Not at that time of year?—A. Dry clover is not like green clover.

Q. I was only giving you a number of causes. Have you not known in your experience animals who have suffered tympanitis, or hoven, the cause being their eating over heartily of various foods; either turnips, or potatoes, or other food?—A. You may have a single case, but you will never have a lot like this.

Q. And a single case resulting in death?—A. Very rarely.

Q. Does not tympanitis, if untreated, generally result in death, if there is no remedy applied, either by an instrument or by medicine?—A. Yes, it will do.

Q. Are not animals who are being fed—who are taken in from grass, and being stall fed—more liable to hoven, or tympanitis, than animals that are at grass?—A. They are not so much subject to it as if they were on green clover.

Q. But I ask you whether animals that are being stall fed, and artificially fed for fattening, are not more subject to the disarrangement that ends in hoven, or tympanitis, than if they were out in the fields?—A. No.

Q. Is not a sudden change of food a very frequent cause of hoven?—A. Well, I have known it in single cases.

Q. Suppose that they have been on turnips and clover for ten days, and not upon cake, and then they get cake?—A. I do not believe that would cause it.

Q. Have you ever read a book called 'White's Cattle Medicine,' edited by W. C. Spooner, veterinary surgeon?—A. I have read it, but it is some time since.

Q. Does hoven consist in the sudden disengagement of gas in the rumen distending the stomach, pressing it against the diaphragm, and thus causing it to become a mechanical means of suffocation?—A. It does.

Q. "Its causes are numerous and varied, and it is of frequent occurrence in

proportion as the animal is moved from its natural state and habits." Do you agree with that?—*A.* Yes.

*Q.* "It is comparatively rare where the animal is out at pasture during almost the whole of the year, browsing at its leisure, but it is most prevalent where an artificial mode of feeding prevails." Do you agree with that?—*A.* No.

*Q.* "Trefoil, or Lucerne, or turnips, or even aftermath freshly cut for the stable, or eaten in the field, are the most frequent causes of hoven." Do you agree with that?—*A.* Yes.

*Q.* Do you also agree with this—"that raw potatoes and unbruised oats, or oats without chaff, may produce it?"—*A.* I believe potatoes may, but I do not think the others would.

*Q.* Well, I will give you raw potatoes?—*A.* Yes, they may do it if the animals were not used to them.

*Q.* According to the generally-accepted notion in the veterinary profession, is not hoven generally attributable to change of food? Do not take the case of numbers, but answer me the question without respect to whether it be one or whether it be a dozen?—*Yes.*

*Q.* Is not hoven, as a rule, generally attributable to change of food?—*A.* It is.

*Q.* You have heard that the cases which were the worst cases were those where 7 lbs. had been given. I mean of those that were not fatal?—*A.* Yes.

*Q.* Did you also hear that there were cases on another farm where 4 lbs. had been given and there were symptoms of attack, but where, without giving any medicine, the cattle got well in a few hours, and were able to feed again that night?—*A.* I did.

*Q.* Did you also hear that there was a third farm, where the cattle only got 3 lbs., and showed no evil consequences?—*A.* I did not.

*Q.* Assume that to be the fact, that some cattle got 7 lbs. of this cake and showed bad symptoms; some got 4, and, without treatment, recovered in the course of some hours without any oil or any medicine, and that others who got 3 lbs. showed no evil effects at all—Would you attach any value to that, as the question of whether or not the amount of food given to the cattle, after being without cake for some days, may have accounted for some of those symptoms?—*A.* I should have accounted for it by their getting some foreign matter amongst the cake, and by their getting the larger quantity instead of the smaller.

*Q.* Did you ever see the contents of the stomach again?—*A.* No.

*Q.* There are four stomachs, are not there?—*A.* Yes.

*Q.* The rumen, the reticulum, the omasum, and the abomasum?—*A.* Yes.

*Q.* And I presume you sent all?—*A.* I sent all the intestines altogether.

*Q.* And their contents?—*A.* Yes.

*Q.* Does anything taken by a cow get absorbed into the system before it reaches the fourth stomach?—*A.* Yes

*Q.* From what stomach do you say?—*A.* It will get absorbed in from the rumen.

*Q.* If there was poison in the rumen—supposing it—would you expect to find some traces of it in the contents of the rumen?—*A.* Well, I do not know about that.

*Q.* I am asking you now what you should expect. Supposing an animal to have taken poison and die in three-quarters of an hour, would you expect to find some trace of it in the contents of the rumen?—*A.* I should fancy so.

*Q.* You did not examine the contents of the mucous lining of the fourth stomach?—*A.* I did not open any of the stomachs at all?

*Re-examined by Mr. FIELD.*

Q. You took out the heart, lungs, liver, and kidneys, and also all the four stomachs, and placed them in a large box; everything just as it was; but do not know what became of them yourself? Would it make any difference in your opinion, or in the result, supposing the intestines had not been examined, but only the heart, lungs, viscera, and kidneys; would that make any difference in your opinion? Do you think an experiment could be made, or a result obtained, from an examination without the intestines?—A. You could know whether the animal was healthy at the time or not.

Q. You were asked with reference to the 7 lbs. of cake that were given at Booth Ferry, 6 lbs. to the cows there, 4 lbs. at the Airmyn Pastures Farm, and at Sancton Farm only 3 lbs., and you gave your answer in reference to that. Now, I want to ask you this—supposing at Sancton the 3 lbs. of cake were given together with chopped hay or oats, would that, in your judgment, tend to diminish the effect of the cake upon the stomachs?—A. Of course it would.

Q. Is it not the fact that the animal's food remains for a long time in the rumen?—A. It is.

Q. It is first, of course, taken in by the mouth and deposited in the rumen?—A. Yes.

Q. From the rumen, under natural circumstances, it goes back to be chewed?—A. Yes.

Q. But remains for a long time in the rumen. Whatever food had been given an hour before would be still remaining in the rumen when the cake would be given?—A. It would.

Q. So that there would be a large mass of food in the rumen, irrespective of the cake, with which the cake would mix as it were?—A. Yes.

Q. You were asked whether you would expect to find in the contents of the stomach traces of poison if poisonous material had been administered? Do I understand that in hoven the effect is to press upon the diaphragm? I think it was so read from that book?—A. Yes.

Q. Does that affect the lungs?—A. It causes a pressure on the lungs.

Q. So that the animal cannot take in its proper quantity of air to decarbonize the blood?—A. No, it cannot.

Q. So that, although there may not be poison in the stomach itself, the blood becomes in effect poisoned by the non-removal of the carbon?—A. It does.

Q. Now, you were asked whether hoven was generally attributable to change of food; in what cases have you known hoven arise from change of food, and what was the change of food?—A. I have known it when they have been taken out from a bare pasture and put into a good clover fog.

Q. Have you known it in any other instances of change of food?—A. I have known it when a single beast has got to a potato pile—or anything of that sort—that has been hungry before.

Q. Where animals have had 7 lbs. of cake regularly from October down to the middle of February and are off cake for say six to ten days, in your judgment would the administration of 7 lbs. then—the ordinary dose—cause hoven?—A. I do not believe it would.

Q. And you see nothing in this course of feeding which in your judgment would cause hoven?—A. I do not.

Professor JAMES BEART SIMONDS sworn: *examined by Mr. FIELD.*

Mr. FIELD: Before I proceed with the examination of Professor Simonds, I ought to say that I have the station-master and the clerk here, who took this box to the station, and if I am put to it, of course I must call them.



Mr. Justice BLACKBURN: I suppose Mr. Seymour will act as he did yesterday.

Mr. SEYMOUR: My Lord, I have not changed my character since yesterday, either as an advocate or as a man.

Mr. FIELD: (to the Witness) Are you Professor of Veterinary Surgery to the Royal Veterinary College?—A. Yes, I am.

Q. For how many years have you held that position?—A. At the present time I hold the position of principal of the Veterinary College, which I have only held since last November, but I have been attached to the Veterinary College as a teacher for thirty years.

Q. And you have had great experience in the examination of animals, their structure and the causes from which accident and death happen to them?—A. I have.

Q. On the 20th February tell us what you received in a box by rail from Mr. Wells?—A. I received from Mr. Wells on the 20th February four stomachs with the spleen attached, two kidneys, liver, lungs, and heart of a shorthorn cow.

Q. What would there be left of the intestines which you did not receive?—A. The so-called large and small bowels.

Q. Were what you received enough to enable you to form a judgment as to the cause of death in the animal?—A. Quite so.

Q. Did you make an examination of what you saw?—A. I made an examination of all the parts, of which I have a note here.

Q. Tell us if you please, what you found upon such examination?—A. The stomachs were full of ingesta, and except two or three small patches of congestion in the lining membrane of the abomasum—that is the fourth stomach—were free from disease. The kidneys presented upon their surface a number of blood spots varying from the size of a pin's head to that of a pea, being the result of extravasation of blood upon the surface and into the structure of the glands—the kidneys—dealing with the kidneys as glands. The lungs were congested in patches and the right one contained two small abscesses full of inspissated pus and evidently the result of disease of the lungs, long since passed away so far as its active form was concerned.

Mr. Justice BLACKBURN: Is the "so far as its active form was concerned" a comment that you add now or from your notes?—A. The words that I have now here in the note are "evidently of a remote date."

Q. No doubt it is exactly the same meaning, but I will take your exact words?—A. It is the same meaning, but I thought from the way I put it, it would be a little clearer. The heart was firm in consistence, of normal colour, but beneath the endocardium—that is in the lining membrane of the heart—were a large number of spots or patches of extravasated blood. The liver was soft but in other respects healthy. The spleen contained a large quantity of black blood. The note goes on to say, the animal from which the above named parts were removed, was an animal supposed to have died from eating newly purchased oil-cake, and several other cattle fed with the same cake showed symptoms of illness. The lesions described are not such as would be produced by an irritant poison.

Mr. FIELD: Now, tell us to what in your judgment was the death of the animal due?—A. The conclusion come to from the examination, was that death immediately depended upon blood poisoning.

Q. And in what manner in your judgment, having heard the evidence given in this cause together with your examination, was that blood poisoning produced?—A. I believe that the blood poisoning was produced by the action of something deleterious immediately upon the nerves supplying the rumen. These nerves are by anatomists known as the pneumo-gastric nerves, or eighth pair.

*Q.* What are the functions of those nerves?—*A.* As their name implies, they supply the lungs and the stomachs—the nervous function is carried to the lungs and stomach and heart by those nerves from the brain.

*Q.* Those you call the pneumo-gastric?—*A.* Yes.

*Q.* Now, will you go on and tell me in your own way about the deleterious influence upon the nerves and the consequence of that?—*A.* The function of the rumen is to receive all the food that is partaken of by the animal, to contain that food for an indefinite length of time, to have the food, while it is contained in the rumen, exposed to the secretion which comes from the viscus and thereby soften the ingesta. The secretion of the rumen being allied to the secretion of saliva, it has a chemical action on the starchy parts of the food, converting them into gum and partly perhaps into sugar. A further function of the rumen is to expel, governed by the will of the animal, a pellet of food from time to time from the viscus into the mouth.

*Mr. Justice BLACKBURN:* What we commonly call chewing the cud?—*A.* Yes.

*Q.* That operation goes on in the mouth when the cud is there?—*A.* The cud is re-masticated—re-insalivated and then swallowed again and passed again into the rumen, where it is subjected to the after process.

*Q.* The same process?—*A.* The same process of exposure to the secretion; besides that, which is a special function of the rumen, the ordinary peristaltic action which belongs to the rumen—the motion by which its contents are, when fitted for digestion, moved on to the other stomach. Anything which interferes with the ordinary peristaltic action would likewise interfere with the special function of the rumen in the act of rumination.

*Q.* And if sufficient in effect would stop the process?—*A.* Stop the process of ordinary peristaltic action; and the result would be that whatever material was contained within the rumen would go into a state of fermentation.

*Q.* What would that produce?—*A.* That would produce in technical language tympanitis, in ordinary language the animals would be hoven or blown.

*Q.* Is that from the gas?—*A.* The gas arising from and mingled with the ingesta, both are in the rumen.

*Q.* And then what would be the effect of that upon the blood?—*A.* The immediate effect would be this, that the rumen occupying more space would press upon the diaphragm. In turn the lungs would be pressed upon; because the function of the diaphragm being to expand the chest, the chest can no longer be expanded, and air cannot be received in due quantity into the lungs in the ordinary act of inspiration. Inspiration and expiration being interfered with in this manner—

*Mr. Justice BLACKBURN:* Then would follow the ordinary consequence of suffocation?—*A.* It may or may not, my Lord, that would depend entirely upon the amount of pressure; but presuming that there is little, or not sufficient, pressure to produce asphyxia there would be pressure enough to prevent the blood being properly decarbonized.

*Mr. FIELD:* And that would be blood poisoning?—*A.* Then, the carbonic acid gas not being thrown out from the lungs, but retained in the blood, would change the properties of the blood, render it unfit for life, and kill the animal.

*Q.* Would that fermentation act upon the nerves?—*A.* The fermentation inside the stomach not in itself perhaps would act materially upon the nerves, but something which gave rise to the fermentation would paralyse them as it were, so that you would get paralysis of the nerves and consequently distension of the rumen from the fermentative action which would be now set up, the vital function being destroyed in short.

*Q.* Have you anything more to say, Professor, in reference to the examination of what you found from your examination of the animals?—*A.* No: the

things which I now give are founded entirely upon what I received at the College, and the history so far as I knew of the case.

Q. Since you wrote that you have heard the evidence given as to the cake, and the administration of it to the animal?—A. I have.

Q. Is it consistent with a cake composed of the elements of which you have heard, taken in the mode you have heard?—A. It is consistent in part with the composition of the cake as it has been described. If I understand the evidence rightly there was certain vegetable matter which was undefined by the chemists in this cake, or by the microscopists. And I cannot perhaps attribute any special action to dodder or any special action as it were to darnel; but at the same time I can understand that both dodder and darnel, and other things that are found in this cake, might have a very peculiar and injurious effect on the pneumo-gastric nerves supplying the rumen.

Q. We heard yesterday of a small portion of mouldy wheat of fungoid growth; would that, in your judgment, if in quantity sufficient, have any effect on the animals?—A. I cannot say that according to the evidence the amount of mouldy wheat was likely perhaps to be injurious to the animals, but in the present state of science we know really very little indeed about fungi and their effects upon the animal organism. I may add perhaps, my Lord, to that, that a few years ago many horses were poisoned by microscopic fungi which were found to affect oats.

Mr. SEYMOUR objected.

The WITNESS: I merely give it as a case in point. You may not admit of it as evidence but I give it as a fact.

Mr. FIELD: You have heard the evidence given as to the mode of feeding the animals, that they were off their feed of cake for 7 days (taking first of all the feeding beasts), and then had 7 lbs. administered to them, that being the quantity they had had from the month of October previously. In your judgment do you see anything in that to cause the hoven, or what you saw in the stomach of the animal?—A. I do not imagine that 7 lbs. of pure cake as it is called, linseed cake, would have produced any ill consequences at all upon any of those animals, administered in the mode and manner, and so on, that I have heard.

Q. Suppose the animal to have had a bushel, or three-quarters of a bushel, I think it is of turnips and potatoes in the morning at about eight o'clock, and then to have had this cake given to him in the afternoon about two, would there be anything in your judgment in that, from the fact of the cake having been given, to account for what you saw?—A. I do not understand your question.

Q. Giving them turnips or potatoes in the morning, would that account for the hoven?—A. Hoven, or the liberation of gaseous matter from the contents of the rumen, will depend very much indeed upon the nature of the ingesta which is already in the rumen. Presuming that these animals had turnips and potatoes, that is a kind of food which would more readily go into a state of fermentation than the ordinary straw or hay.

Q. Then having that in the morning, and then being fed on wholesome cake, and having it ever since October, do you see anything that would lead you to suppose the consequences were due to the turnips and potatoes?—A. Certainly not to the turnips and potatoes, but due to something which was given afterwards, which set up the fermentative action of the turnips and potatoes.

Q. Would wholesome linseed-cake have set that up?—A. Certainly not.

Q. You have heard that the cows had a feed of mangolds which had been drawn in October and piled and put in a shed—would that have produced it?

—A. Not exclusively.

Q. With wholesome cake would that produce it?—A. Again they would go

more readily into fermentation than food of an opposite kind that did not contain so much water.

Q. But admitting the habit of feeding the animals to be what you have heard, would 7 lbs. of wholesome cake produce that?—A. Certainly not; I myself, in own experience as a farmer, feed animals largely with mangold-wurzels, and I have heard something of a bushel being given to these animals; well, I myself had a bull who used to eat ten bushels of mangolds a day and never was tympanitic.

Q. With regard to the quantity at one farm that was given, we heard that the beasts had 7 lbs., the cows 6 lbs.; the quantity at the Airmyn Pastures was 4½ lbs., and the quantity at Sancton was 3 lbs. mixed up with chopped clover or chopped hay. Would those quantities induce you to say that this illness was due to any wholesome cakes?—A. Wholesome cake in no instance would have produced any mischief, but the results set up in the rumen which were shown by the amount of distension of the animals, and so on, and the tremor which was described—

Q. Would those be in the proportion to the amount of deleterious matter that was carried into the rumen of each animal, depending upon idiosyncrasy as well?—A. Of course.

Q. And would the mixture of chopped hay with the cake diminish the deleterious effect on the stomach?—A. So far as the disengagement of gaseous matter is concerned, there being no roots there.

Q. Under what conditions have you known hoven or tympanitis to be produced with regard to change of food or otherwise?—A. It is far more likely to occur in the spring of the year, when animals are turned from out of straw yards and sheds, and so on, into pasture-grounds; but more especially if turned into green growing clover; and more especially also if turned out early in the morning while the grass or clover is wet with dew; consequently in some parts of the country the disease is called “dew-blown.”

Q. Do you know of any other conditions under which the disease has existed?—A. Tympanitis not unfrequently exists as a symptom of disease of various kinds existing in the organism of the animal.

Q. But that you negative in this case from the examination of the animal?—A. Entirely so.

Q. I think you told us to what, in your judgment, the patches of extravasation under the endocardium were due?—A. They were due to the non-decarbonization of the blood, to the blood consequently becoming poisoned and leaving its vessels, as it is always known to do when it is in that impaired condition.

*Cross-examined by Mr. DIGBY SEYMOUR.*

Q. If I understand you, you have given blood-poisoning as the result of non-decarbonization, that itself being the result of the process of fermentation and the pressure resulting from it which has been set up in the rumen?—A. I do in certain cases, not in all cases.

Q. In an ordinary case of tympanitis—tympanitis, for instance, from eating an excess of clover, which you have yourself described—what would be the symptoms?—A. The animal's head would be thrown out, its mouth in all probability would be open, its tongue protruding, its eye fixed, the head absolutely horizontal, so as to carry on the respiration with greater facility, the abdomen greatly distended, and upon percussing the left side of the abdomen, a tympanitic sound.

Q. And the feet standing in a fixed posture?—A. When it is an extreme case the animal stands fixed.

Mr. Justice BLACKBURN: Would there be any difference between the symp-

ptoms of hoven which was produced by one cause, and hoven produced by another?—*A.* No essential difference: there would be a modification depending upon the extent. I took an extreme case just in order that the learned counsel should understand it better.

*Mr. Justice BLACKBURN:* It comes to this result: that whether hoven was produced by cake or potatoes, its outward symptoms and appearances would be the same?—*A.* The ordinary symptoms would be the same, but modified according to the cause and the amount or extent.

*Mr. SEYMOUR:* But the ordinary symptoms—the moaning, the symptoms of distress, the protrusion of the tongue, the staring coat?—*A.* Well, I do not care much about the staring coat—staring eyes.

*Q.* Well, but to-day we heard a good deal of it. They would all be produced by hoven, whatever the cause was?—*A.* Quite so.

*Q.* And may I ask you this, Professor Simonds: is not a frequent cause of tympanitis a sudden change of food?—*A.* Well, I cannot say it is a frequent cause, for it is a remarkable fact with regard to ruminating animals, that they often extend the rumen with solid ingesta and there is but very little gas existing with it. You will find an animal eats to repletion, its rumen becomes distended, and its power of expelling its contents impaired; but there is no fermentation going on, or but very little indeed. We divide distension of the rumen into gaseous distension, and distension from solid ingesta.

*Q.* I do not know whether that is a definite answer to my question. I asked you whether a frequent cause of tympanitis or hoove is not the alteration of food?—*A.* Oh, it is a cause undoubtedly.

*Q.* That is one cause, undue quantity of course is another?—*A.* Yes.

*Q.* You gave the case of cattle feeding upon a heap of potatoes?—*A.* Yes.

*Q.* And another, if I understand you, would be if food, which was impregnated or affected with moisture, such as mangolds, was taken in with any other food given at the time, which might be calculated to produce chemical action or fermentation in the rumen?—*A.* I take it esculent vegetables—turnips, potatoes, mangolds, or any of those things, just in proportion to the amount of moisture that they contain—would have the effect of the disengagement of gaseous matter from them if fermentation is set up.

*Q.* Suppose mangolds taken from a field in wet weather three or four days before and then given to cattle kept in a farm-shed, and given in the quantities you have heard in this case, would not such mangolds contain a good deal of moisture that would be likely to facilitate fermentation?—*A.* Mangold does not contain very much moisture in the month of February; it is taken up in October as a rule, and put into heaps, and it has got dry in the ordinary process; but of course if taken up in wet weather, and laid on the surface of the ground and not dried again, it would contain moisture.

*Q.* According to the degree to which it was moist it would be more likely to yield to rapid fermentation when brought into contact with other food?—*A.* Just so.

*Q.* Now would not the giving of cake to cattle after the cattle had not been fed upon cake say for ten days, be likely to set up a fermentation if there was any damp mangold or similar vegetable in the rumen?—*A.* Certainly not; not pure cake.

*Q.* Do you attach no importance to the fact of the cattle being for ten days without any cake?—*A.* No practical importance whatever.

*Q.* Do you draw any line with regard to the amount of cake that you would give to cattle, pure cake for instance?—*A.* Cattle will very frequently take 2 lbs. of pure oil-cake day by day.

*Q.* Is not that a large quantity; would you begin with 12 lbs. after cattle had been for ten days without?—*A.* No; but I should see no objection to begin with 7 or 8 lbs.

Q. You would not begin with 12 lbs.?—A. I should not.

Q. Do not you think it would be safer, looking to the possible effect of the mangold or other food fermenting in the rumen, to begin with 3 or 4 lbs.?—A. But good linseed-cake, as cake, will not produce the morbid action on the nerves of the stomach, and therefore will not give rise to the fermentation. I want to impress that upon your minds.

Q. I am not asking about that, but about the chemical action from coming in contact with other food in the rumen?—A. But there is no chemical action set up in the cake itself.

Q. Pardon me for a moment. You say you would not give 12 lbs. to begin with. Suppose the case of an excessive quantity of pure cake, more than what you think it would be safe to give, how would it act upon the animal?—A. Cloy the appetite, and probably on the next day you might find the bowels a little relaxed.

Q. Do you mean to say there is no chemical action set up in the rumen when you give pure cake after the animal has been feeding upon potatoes or turnips, or chopped straw?—A. Not necessarily at all.

Q. Not necessarily! I am asking you as a scientific man. I ask you when an animal has been feeding upon potatoes or turnips, or chopped clover, and you give pure cake, is there no tendency for a chemical action to be set up?—A. I cannot say there would be no tendency, but we only judge of things by their effects, and there is no tympanitis produced in those cases.

Q. That will depend entirely upon the degree of fermentation set up?—A. But there can be no fermentation without a sufficient disengagement of gaseous matter, and that cannot escape; and therefore it accumulates in the rumen, and hence you have an explanation of why some of these animals were more tympanitic than others. There was a larger amount of gaseous matter liberated in some than in others, in proportion to the extension of the cause and effect.

Q. But you have lectured upon this subject, I think, Mr. Simonds?—A. Probably.

Q. In cases of tympanitis, without any reference to cake at all, where it has been set up from alteration in food—take the case of a stall-fed ox taking clover—how is the fermentation set up?—A. Frequently by over-distension from green food; frequently from the animal not thoroughly masticating as much as it might do, turnips or mangold wurzel, or potatoes, just in the same way as we suffer if we eat of them. There is no true digestive process going on in the rumen; there is no gastric juice in the rumen; there is none till you come to the abomasum; therefore there is not the same amount of controlling power over the fermentative action in the rumen that there is in the abomasum, the controlling power of the fermentative action being the secretion of the gastric juice, and the action of the gastric juice on the material. If we ourselves eat heartily and do not masticate, we know the effect of it is that a certain quantity of it, although exposed directly to the action of the gastric juice, is digested while another portion of it goes into a state of fermentation, and we get flatus.

Q. I will just ask you this question. Probably it is because I do not comprehend your answer that I repeat it. Where you have tympanitis, the result of an operation of an evolution of gas from a fermentation set up in the rumen, I want to know how that fermentation is occasioned, where it is the result of an alteration of food, for instance? What is the chemical process that goes on there?—A. It is that which belongs to fermentation altogether, and you have carbonic acid gas liberated from the material itself.

Q. Do you mean the new material?—A. No.

Mr. Justice BLACKBURN: I rather think you are at cross-purposes. The witness is explaining how fermentation goes on when once it is instituted

and I rather understand Mr. Seymour to be asking how does fermentation begin—what causes it.

Mr. SEYMOUR: Precisely so. Once you have got fermentation, I can understand the distension, and the disease, and the death.

Mr. Justice BLACKBURN: Quite so; and I understand your question to be, what starts the fermentation in the case you are alluding to, not what follows after it when once it has begun?

Mr. SEYMOUR: Yes, my lord. (To the Witness) You may take fermentation from a thousand other causes, excluding the cake altogether.—A. You must take each cause into consideration in answering a question of that kind. For example, supposing that you give mangold wurzel to an animal and it imperfectly masticates the mangold wurzel, the ordinary application of the heat and moisture, as it were, of the rumen, is sufficient at once to set up fermentation in mangold wurzel badly masticated; the same with regard to turnips, and the same with regard to potatoes.

Mr. Justice BLACKBURN: Yes, but what prevents it being set up in mangold which is properly masticated?—A. The function of the rumen being properly performed.

Q. That is another step. How does it prevent it?—A. The ordinary function of the rumen is that of expelling the food into the mouth that it may be re-masticated. That is one function. The other is emitting its contents from time to time into the other stomach, by ordinary peristaltic action. These functions are interfered with under the circumstances to which the learned Counsel has alluded.

Mr. Justice BLACKBURN: I do not think it is quite explained in your answer.

Mr. SEYMOUR: I will read you a line or two from a lecture of your own. In the 'Veterinary Record,' speaking of "hoven," you say, "This disease may occur at any period of the year, if cattle are subjected to a certain alteration of diet. It, however, takes place more often in the spring and autumn?"

—A. That is a Lecture before the Agricultural Society.

Q. It gives us a very graphic account of the swelling and distension of the cow, and so on?—A. It was a popular lecture, you must remember.

Q. Popular! But being by an able Professor, I have no doubt there was no popular fallacy in it?—A. Thank you for the compliment.

Q. "The disease may occur at any period of the year if cattle are subjected to a sudden alteration of diet." Now, I want to get you to this. We start with this principle: that, on the authority of Professor Simonds, the disease may occur when cattle are subjected to a sudden alteration of diet?—A. Yes.

Q. Now I want to know this, chemically speaking, where tympanitic action arises from a sudden alteration of diet, how does the chemical action begin in the rumen? What is it that sets the mischief afloat?—A. The suspension of the function of the rumen for the time being.

Q. What suspends the function of the rumen?—A. Why the impairment of the nerves supplying it.

Q. What produces that impairment of the nerves?—A. The direct effect on the coats of the rumen of the material that is taken.

Q. What produces that direct effect?—A. It depends entirely upon what the agent is. If I take badly masticated food—if I swallow food myself, as I said just now—a certain quantity is digested, and another quantity goes into fermentation. I cannot go beyond that.

Q. I am not upon that, I am upon an alteration in diet?—A. Well, but then an alteration in diet frequently leads to an imperfect mastication of food; and I had reference to neither hay nor straw, nor anything of that kind, but to turnips or mangold wurzels, when I wrote that.

Q. But would turnips alone, or mangold wurzels alone produce an effervescence?—A. To be sure.

Q. Would turnips and mangold wurzel, when coming in contact with drier food, such as chopped clover or straw, have a greater tendency to fermentation?—A. No, they would not have a greater tendency. I do not think they would have so great a tendency, because they are mingled with a certain quantity of what farmers know as dry food.

Q. But if you give wet moist food instead of dry, would not the tendency be to create a more rapid action?—A. Certainly.

Q. Then, let us understand, if an animal has been having dry food, such as chopped clover or chopped straw, and then you give it food that is moist, and you find afterwards that that animal had an attack of tympanitis, would you account for it chemically by the action of the dry food and the moist food setting up a fermentation which resulted in tympanitis?—A. I should chemically account for it in the moist food setting up an action first, and then that action extending to the dry food.

Q. You have answered my question now. That is what I meant, at any rate, whether it is worth anything or not.—A. I thought you were going into vital laws and chemical laws, which were out of my beat. Your question was one I could not understand.

Q. Is Professor Gellé of Toulouse, who is quoted by Mr. Youatt in his work on cattle, looked upon as an authority?—A. He was. But he has been dead twenty years.

Q. But, as in the case of lawyers, I suppose old law is not worse than new law?—A. Just so. His is old physiology.

Q. Do you agree with this: "It is comparatively rare" (that is the hoven), "when an animal is out at pasture during that part of the year, browsing at leisure, but it is most prevalent where an artificial mode of feeding prevails"?—A. I agree with it in part. That is an observation made by Spooner.

Q. It is not an observation by Spooner, it is a note in Spooner's Edition of 'White,' taken from Youatt—Youatt quoting it approvingly, from Professor Gellé?—A. Quite so. It is like law, you know, partly true, and partly untrue. Everybody knows perfectly well that if you have an animal out at grass the whole summer through, it very rarely indeed has tympanitis; everybody also knows perfectly well that if an animal while at grass is shifted from one piece of pasture-ground to another where there is a very luxurious herbage, which is tempting to the animal's appetite, and especially if also the weather is wet, it is likely to become tympanitic.

Q. Does not it also come to this, that animals in their wild or natural state when out at pasture are less likely to become subject to tympanitis than stalled animals?—A. Oh, unquestionably, animals in a state of nature are less likely.

Q. I think we had an illustration of that yesterday, when we heard that the animals on being turned out loose into the fold-yard after being attacked at one of the farms, soon got better?—A. Yes, but I would not call those animals in a state of nature, I should call wild animals animals in a state of nature. We place the animals as much in a natural condition as we can.

Q. Animals unartificially fed are not so liable to tympanitis as animals that are subjected to a course of artificial feeding?—A. No.

Q. I think in your notes upon the state of those animals at that time you did not make any of those suggestions as to the cake-feeding, of course?—A. Yes.

Q. Will you just read the note you have got there?—A. "The animal from which the above-named parts were removed was supposed to have died from eating newly purchased oil-cake. Several other cattle fed with the same showed symptoms of illness. The lesions described are not such as would be produced by an irritant poison." The note stops there, but, of course, it meant to say that the cake itself did not contain an irritant poison.



Q. Quite so, and I suppose it is by hypothesis, as far as the quantity is concerned. When you say, for instance, that dodder and darnel are poisonous, I suppose it would depend upon whether they were present in sufficient degree to operate as poisons?—A. I do not attach much importance to those things. We can only judge of certain things by their effects. Neither the microscope nor chemistry will throw very much light upon certain things, as you are probably aware.

Q. I will take darnel; that is a narcotic?—A. Yes.

Q. I suppose it would require a considerable portion of darnel to act injuriously on an animal?—A. Of course it would in itself.

Q. And a small quantity of darnel would not be calculated to produce tympanitis?—A. Not in itself.

Q. Take dodder. Is not dodder-cake a popular article of food on the Continent and in parts of England?—A. I do not know that it is. I do not think dodder is produced (I am not speaking from my own knowledge, but this is my impression) in sufficient quantities to be made into a cake, either on the Continent or in England. But you have Professor Voelcker here who will answer that question in a minute.

Professor VOELCKER re-called: *examined by Mr. SEYMOUR.*

Q. Do you know of dodder-cake being used on the Continent?—A. It is, as food.

Q. For cattle?—A. Yes.

*Cross-examination of Professor SIMONDS continued.*

Q. This darnel being, as far as it goes, only a narcotic, and having just heard from Dr. Voelcker that the dodder is used for food, let me ask you this, you have instanced those two things, surely you would not attribute the death of the cattle to either of them?—A. I do not, I never have.

Q. Well, suppose I could prove to you that this cake which they got was a nutritious and sound linseed-cake; suppose I prove that it contained a proportion of 50 per cent. of purest Calcutta linseed, that it contained a proportion of about 30 of pure sesamé cake, such as we have heard of yesterday as being used as a wholesome food, and the result of making oil for the use of man, and that the remainder was pure good bran, would you say, under those circumstances, that that was a bad food for cattle?—A. I should not say it was a bad food for cattle; but, nevertheless, I should say that, so far as this individual cake, whatever its composition may be, is concerned, it contains something, which when it was exposed to the action of the secretion of the rumen was liberated from it, and had a deleterious effect on the nervous system. You know here are sixty animals, as we had proved from the feeders yesterday, all of which had a certain quantity of the cake given them, and upon all of which a certain effect is produced. It is not coincidence, it is consequence—must be.

Q. Oh, then, you are governed by the fact of the supposed effect?—A. Of course I am.

Q. Have you at all considered this, that it was, as a rule, one beast out of each of the three in each stall that was the worst?—A. Exactly, it would be in proportion to their idiosyncrasy, and the quantity that they would eat. But then one person may eat a pound of beefsteak, and another can only eat half-a-pound.

Q. If there was poison enough to kill in that cake, would not you expect to find some of it in the contents of the rumen or the stomach?—A. Certainly not, if it were a vegetable poison.

Q. Would not you find it on the mucous of the fourth stomach?—A. No; you sometimes, if an animal is poisoned with yew, for instance, may trace poisoning by vegetable matter by observing some of the materials in the stomach; but if the material is comminuted and ground up, and so on, that evidence is removed from you altogether.

Q. Do you mean to say that you could not find any trace, or anything to guide you after death, in an animal that had been poisoned by vegetable poison, either by inflammation of the mucous or otherwise?—A. No, some poisons, vegetable poisons, produce their action directly on the nervous system, and never produce anything like inflammatory action. Take prussic acid—the animal dies instantly.

Q. Yes, but prussic acid is a peculiar thing.—A. I only give it you as an illustration. I could give you a dozen others.

Q. Would you not expect to find some inflammation set up on some portion of the internal structure?—A. If the animal died from an irritant poison I should, but if it died from a narcotic I should not.

Q. Then, on the whole, may I take your evidence to be this, which I think you have already given me, that, so far as you could detect anything in your *post mortem* examination of this animal, you found nothing inconsistent or differing from that which you have found in ordinary cases of death by tympanitis?—A. In an ordinary case of tympanitis death is produced generally by asphyxia, as I have attempted to explain; I did not say that in this case death was so produced.

Q. I am asking you upon the *post mortem* examination, not upon the history before the death, taking the condition of the animal after death as you saw it, was there anything to distinguish it from the symptoms existing in cases which you yourself lectured upon in this book?—A. No.

Q. You spoke of some appearance upon the mucous of the fourth stomach, "extravasated blood, but only here and there in the kidneys and heart in patches, in the third stomach and fourth stomach"?—A. Quite so.

Q. Well, but now do you attribute in any way to the cake the appearance of the fourth stomach?—A. Not to the local action of the cake, but to the indirect action on the blood, and the blood then leaving the vessels in different parts of the body.

Q. Then would you find a similar appearance in a case of ordinary tympanitis?—A. If the animal died from blood-poisoning produced by tympanitis—produced by tympanitis arising from any cause.

Q. Then, in fact, that also would be consistent with the blood-poisoning arising from non-decarbonization set up by the pressure of the diaphragm?—A. Blood-poisoning produced in any way.

Q. I understood you to say that pressure not sufficient to produce death by suffocation is sufficient to produce it by non-decarbonization?—A. Quite so.

Q. You say the liver was affected, was that recent or remote?—A. I attributed that, to a certain extent, to the slight decomposition which was going on. We find the liver affected very speedily in animals which die.

Q. You are not able to say whether that was recent or remote?—A. I should say it was *post mortem* more than anything else.

Q. More than anything else?—A. That is to say, there was no structural disease in the liver.

Q. You spoke of an abscess.—A. I spoke of an abscess in one of the lungs.

Q. Would the blood spots in the kidneys be the result of tympanitis?—A. Let them be found where they would they would be all referable to the same cause precisely.

Q. And you may find blood spots of the same kind arising from the same cause?—A. All over the body, and they may arise from any cause.

*Re-examined by Mr. FIELD.*

Q. When was this lecture given?—A. Probably twenty years ago.

Q. It was given in October 1848 I see.—A. Yes, I thought it was about that.

Q. And M. Gellé that we have heard about—how long ago did he die?—A. Oh! he has been dead many years; I cannot say how many.

Q. This book was published in 1848, and that is a note of M. Gellé's some years before.—A. Some years before.

Q. I suppose something has been learned by the scientific world and the surgical world since 1842?—A. A great deal.

Q. And since 1848?—A. A great deal.

Q. I think Liebig had not begun to write at that time, had he?—A. I do not know.

Q. You say, "The disease may occur at any period of the year if cattle are subjected to a sudden alteration of diet." Did you see anything in the change of diet here to account for what you have heard described as being due to the diet of the beast being changed?—A. The only account that we have heard of diet is that of the exhibition of this cake, containing something deleterious.

Q. With regard to the cake, you say you found no irritant poison in it?—A. Yes.

Mr. Justice BLACKBURN: That was in the intestines?—Yes.

Mr. FIELD: Supposing dodder-cake or sesamé-cake to have been damaged or heated by the damp, would they contain the elements of self-fermentation, in fact?—A. Yes. Damaged cake is very likely, indeed, to undergo fermentation.

Q. Whether sesamé or dodder?—A. Sesamé, or dodder, or linseed, or any other.

Q. With regard to imperfect mastication, I suppose, if ground up and mixed with the other cake, you could not distinguish it; I mean if it was ground up very fine and mixed with the linseed?—A. I am not a sufficient microscopist to say whether you might not discover some slight traces of it; but I think, again, we know at the present time not sufficient; we know a great deal, but not sufficient to recognise all these things by the husks and portions of seeds which are ground up when a cake is microscopically examined.

Q. You have been asked about imperfect mastication; you have heard that these animals were perfectly healthy in the morning, and, feeding as they did, do you see any reason to suppose that they did not as perfectly masticate that morning as any other morning?—A. Certainly not.

Q. With regard to the mangolds, you have heard that they were in a pile, thatched, and brought into a covered place; do you see any reason to suppose that there was any damp in the mangold itself to set up an unhealthy action?—A. I should think not myself. According to the evidence before us the mangold was in an ordinary condition.

Mr. FIELD: That is the Defendant's case.

Mr. Justice BLACKBURN: What I am going to ask is not at all in the nature of a cross-examination, but in order to see if I have thoroughly understood you. In the first place, if I understand you rightly, the view you take of this matter is that the contents of the rumen, for some cause or other, fermented, and that then the fermentation of the rumen produced gas that would come from it, and thus produce pressure which caused death?—A. I do my Lord.

Q. I believe we all understand that much now; but what I want to understand is this—I suppose any vegetable matter that is moist and warm, as anything in the stomach would be, will ferment by itself?—A. Yes, if uncontrolled by the vital act.

Q. Precisely so: now, if I understand you rightly (and that is what I want

to see), when the rumen is healthy, and proceeding in its ordinary and normal state, it does control that, and prevent its fermenting?—*A.* It does.

*Q.* And that anything which would stop that action would allow the fermentation to begin?—*A.* Yes, interfere with vital laws.

*Q.* By taking away the controlling cause?—*A.* Yes. =

*Q.* Now I want to know how rapidly would that be, supposing something caused the rumen to cease to act? Would the fermentation begin instantaneously, or would it take an hour, or what?—*A.* It begins very quickly. Perhaps your Lordship would allow me to give a case in illustration.

*Mr. Justice BLACKBURN:* Taking shortly the substance of what I understand you to say, I have written down this, and I want to see if I have correctly understood you. "That if the controlling vital action of the rumen which prevents fermentation is suspended by any cause, fermentation begins very quickly."—*A.* Yes.

*Q.* Now you are going to tell us what you mean by "very quickly."—*A.* Take some animals in the morning from out of a straw-yard; put them into a field of clover to graze, and it not unfrequently happens that, within two hours from the time they were turned out, they will be found dead from tympanitis.

*Mr. Justice BLACKBURN:* Then the next thing I want to understand is this, you draw your conclusion—it will be a question for the Jury to say whether they do the same—you draw your conclusion from the animals having all fallen ill, that something must have produced the effect that suspended the controlling power of the rumen?—*A.* Something, my Lord.

*Q.* That, of course, is a question for the Jury, which they will form their opinion on. Now, is there anything which you have been able to see, either in the contents of the stomach or in the oil-cake (which I do not know whether you have examined yourself or not), is there anything which you have been able to detect which would, as a poison, produce that suspension of the function of the rumen; I mean if the taking of the oil-cake did stop the action of the rumen, of course the conclusion would be there must have been something there; but, independently of that, have you been able to detect any trace of that either in the intestines of the animal or in the specimens of the oil-cake?—*A.* I have not examined the specimens of the oil-cake, and should not consider myself a sufficient authority upon the subject were I to do so; but, so far as the contents of the rumen were concerned, I did not observe anything whatever in the contents to account for it.

*Q.* There was something in your last answer about damaged cake. Supposing there was a cake that got damaged, it might only be more or less fermented and spoilt; but I did not understand your answer to Mr. Field. Would cake that had got fermented or mouldy affect cattle? Have you known instances in which such cake has acted upon cattle so as to stop the healthy action of the rumen, and consequently produce hoven; or is it merely that you say such things may be, and, in the imperfect knowledge existing upon the subject, you cannot say whether it is so or not?—*A.* I have never known damaged cake to produce tympanitis, but I have often known damaged cake to produce a deranged state of the other stomachs and intestines.

*Mr. Justice BLACKBURN:* That is really all I wished to see—whether I understood you rightly. It was rather because I was not quite clear if you and Mr. Seymour were thoroughly understanding each other. I take it that where there is anything that is capable of fermentation you may set the fermentation going chemically, as you do when you put yeast amongst sugar and water, and make it ferment. That is one thing; but you do not attribute, as far as I understand you, the fermentation which existed in these animals to the cake, in the way in which yeast would set it fermenting?—*A.* No.

*Q.* I do not understand you to say that it started the chemical action in

that way, but that it somehow or other affected the nerves of the rumen so as to take away the controlling cause that prevented the fermentation?—*A.* That is the view I take of it.

Mr. Justice BLACKBURN: Very well, that ends the Defendant's case.

Mr. SEYMOUR: Then I will now begin the Plaintiff's case in reply.

SAMUEL GEORGE KIDD, sworn: *examined by*  
Mr. SEYMOUR.

Q. Are you an oil-merchant and seed-crusher carrying on your trade at Hull?—*A.* I am.

Q. And have you carried it on for some years?—*A.* I have.

Q. In a very large way?—*A.* Well —

Q. In a large way?—*A.* Yes, I think I stand fourth as far as the quantity of cake we make is concerned.

Mr. Justice BLACKBURN: At Hull, I suppose you mean?—*A.* At Hull.

Mr. SEYMOUR: In the trade, have you known brands that distinguish the different cakes and the different manufactures?—*A.* Yes.

Q. And are there differences in the cake known among the commercial world—one cake from the other—both in price, and in name, and character?—*A.* Certainly.

Q. I believe there are three broad distinctions—what you call pure cake, genuine cake, and ordinary cake?—*A.* Generally speaking.

Q. The cake that we have heard of in this case was supplied to Mr. Wells: what was its brand and name?—*A.* Supplied to Messrs. Ayre, Brothers?

Q. Yes?—*A.* "Triangle best."

Q. Have you a brand known as triangle cake simply?—*A.* We call them "triangle common, or plain triangle."

Mr. FIELD: It is not marked "triangle common."

Mr. SEYMOUR: There is "triangle,"—plain triangle,—and "triangle best."

Mr. Justice BLACKBURN: As I understand I think we have it already from his evidence that some of them are stamped with a triangle and the word "best," and others are stamped merely with a triangle.

Mr. SEYMOUR: Yes, and in the case of others they are marked with a Diamond, and a K in the middle.

Mr. Justice BLACKBURN: I think the Diamond K, if I understand Mr. Ayre right, has got a word attached to it?

The WITNESS: "Pure."

Mr. SEYMOUR: Are the triangle and triangle best degrees of what you call ordinary mixed cake?—*A.* Mixed.

Mr. Justice BLACKBURN: But if you say a thing is "triangle best linseed-cake," is that telling people that it is not a linseed at all?

Mr. SEYMOUR: Yes, mixed cake.

Mr. Justice BLACKBURN: I mean, if you say that Mr. Kidd has advertised, "I sell, under the name of 'triangle best linseed,' stuff which is nearly half of it composed of other things," well and good; but if he sells it as linseed-cake, when, in fact, it is not, he can never get out of that being a cheat on the public.

Mr. SEYMOUR: You have heard my Lord's observation; as a matter of advertising, and as a matter of knowledge in the commercial world, is "triangle best" known to be a mixed cake or a pure cake?—*A.* A mixed cake by every buyer.

*Q.* Is there a difference in the scales of prices for each of these cakes?—*A.* There is.

*Q.* Just tell me what the prices are?—*A.* The "triangle best" is 25s. per ton —

Mr. FIELD: I do not see how all this bears on the issue.

Mr. Justice BLACKBURN: If Mr. Seymour can prove what has now been stated, that it was made public to everybody that this was not linseed-cake at all, and that it was known as such, why, undoubtedly, the imputation which there is here, that it was sold as linseed-cake, when it was not, would be shown to be untrue.

Mr. SEYMOUR: The libel says it was sold as best linseed-cake, it does not say Triangle best.

Mr. Justice BLACKBURN: It does not. If you can show that Messrs. Ayre told Mr. Wells before he bought it that it was not linseed-cake, but a mixture, then you do a great deal indeed to show that the libel is a libel and untrue.

Mr. SEYMOUR: I will undertake to show that.

Mr. FIELD: Mr. Wells was never asked that question.

Mr. SEYMOUR: You stopped me. I was going to ask it.

Mr. FIELD: That was afterwards.

Mr. SEYMOUR: Do you know this circular (handing a circular to the witness)?—*A.* Yes.

*Q.* Now are those circulars to your knowledge circulated widely and broadly amongst the farmers in various counties of England?—*A.* From the North of Scotland to the South of England—all over the country.

*Q.* And do they draw a distinction?

Mr. Justice BLACKBURN: We had better see what they do do.

Mr. ROBERTS: There are a series.

Mr. Justice BLACKBURN: But do they differ in any way except in price?

Mr. SEYMOUR: I do not think they do.

Mr. Justice BLACKBURN : Very well, then, if you give one to Mr. Field, it will do.

The ASSOCIATE : Am I to read it?

Mr. Justice BLACKBURN : Probably it will be simpler to hand one to the jury.

Mr. FIELD : The heading is important.

Mr. Justice BLACKBURN : " Issued to the trade only."

Mr. SEYMOUR : I will show these were sent to Mr. Wells.

Mr. FIELD : I object to that : your Lordship sees they were not put to Mr. Wells when he was in the box.

Mr. Justice BLACKBURN : What of that, if Mr. Wells got the circular.

Mr. FIELD : Not these.

Mr. Justice BLACKBURN : If these were not circulars sent to Mr. Wells, that is another matter.

Mr. FIELD : They were not.

Mr. Justice BLACKBURN : Then, gentlemen, we are under a mistake. I have admitted them by mistake.

Mr. SEYMOUR : In the action of *Wells v. Ayre*, Mr. Wells has admitted among the admissions in the cause —

Mr. Justice BLACKBURN : Mr. Wells said he had received circulars from the Plaintiffs, but he did not state, nor do I at all know whether it is the fact or not, that he received these circulars.

Mr. FIELD : No, my Lord; and my instructions are that he did not; they are quite different from what he received.

Mr. Justice BLACKBURN : Let us get this, that is what I want to know : are the circulars which were sent to Mr. Wells—which yesterday were shown to Mr. Wells, and he said apparently that he received them—are those the circulars which you are now putting in?

Mr. SEYMOUR : Those and another, my Lord.

Mr. Justice BLACKBURN : You had better call back Mr. Wells, and let us see how that is, for Mr. Field seems to dispute it.

Mr. FIELD : I object to any admission in another action.

Mr. SEYMOUR : Call Mr. Wells.

Mr. Justice BLACKBURN : Admission in another action there cannot be; but let Mr. Wells be recalled. He spoke yesterday of some circulars which he had received, which were not put in; but let him be recalled, and he will tell us what circulars he did receive.

Mr. WELLS re-called : *examined* by Mr. SEYMOUR.

Q. Did you receive circulars from Messrs. Ayre?—A. I have for several years.

Q. Their ordinary trade circulars?

Mr. FIELD : Do not say what they are.

Mr. SEYMOUR : Just look at that (handing a circular to the witness)?—A. Circulars of that character?

Mr. Justice BLACKBURN: Look at one of them, and see if it was one of those that you received?—*A.* I see all this class, my Lord; they come every week, and they are thrown away.

Mr. Justice BLACKBURN: Well, I know, but this is headed “Issued to the trade only”—were those you received headed so, or is this a separate one?—*A.* They are precisely like this.

*Q.* And headed with “Issued to the trade only” at the top?—*A.* I see no difference; yes, it is so.

Mr. Justice BLACKBURN: Well, now then, Mr. Field, he received the circulars.

Mr. SEYMOUR: To prevent your being recalled again, let me ask you this—have you also received a circular like this (handing another circular to the witness)?—*A.* I may, but I do not remember that one in particular. I won't say I did not, but I won't say I did.

Mr. SEYMOUR: That is another which was shown to Mr. Wells yesterday—“triangle best.”

Mr. Justice BLACKBURN: Then that will do, you can hand those circulars back to the jury, who will see what they are, and what the effect of them is.

Mr. SEYMOUR: Would your Lordship allow me to ask Mr. Wells this question—whether he did not know that this was a mixed cake?

Mr. Justice BLACKBURN: Ask him if you like.

The WITNESS: I did not know it was a mixed cake.

Mr. SEYMOUR: Not paying 10*l.* for it?—*A.* No. I have been in the habit of buying what they call “genuine linseed-cake,” which was at that time 2*s.* 6*d.* a ton less, from Wright, Brothers.

*Q.* Did not you call at Mr. Ayre's office, and have a conversation about this very cake?—*A.* After the cake was purchased.

*Q.* Before?—*A.* No, after the cake was purchased by correspondence. I was not at that office till nearly a fortnight afterwards, and the whole of the correspondence is before you. I originally received a small sample with a note inside, offering me 20 tons at a certain price.

*Q.* Did not you at that interview tell Mr. Ayre that you knew it was mixed cake?—*A.* I did not.

*Q.* Had not you been in the habit of buying the “W. B. Cake”?—*A.* Yes, from Wright, Brothers—“W. B. Genuine.”

*Q.* Is not that mixed?—*A.* I believe not. I believe it to be a cake that is made from the seed without being entirely sifted. I have always understood it so.

*Q.* Then you believe it had foreign elements in it?—*A.* What I believed was this—that the pure cake was entirely sifted, and the “W. B. Genuine Cake” was that which had a portion of the siftings left in.

*Q.* Do you buy of Pickerings —

Mr. Justice BLACKBURN: Recollect, Mr. Seymour, that we had Mr. Wells here all day yesterday, and he was cross-examined. He was only recalled now in order to prove the circulars.

### *Examination of Mr. KIDD continued by Mr. SEYMOUR.*

*Q.* Well, now Mr. Kidd, the circular has been before the jury; in this circular the cake is described as “Best,” “A. C. Best,” and “Pure.” Now I ask you again, whether, taking the price of this cake, and the knowledge of the commercial world, it is not known that “Triangle Best” is a mixed cake?—*A.* I have never sold “Triangle Best” to one of my buyers without their being



informed of what those cakes consisted—not one in the whole of my experience as a crusher—not one—either a large quantity or a small quantity.

Q. Of what is the “Triangle Best” cake made?—A. Of good fine linseed, sesamé-cake, and bran.

Q. In what proportions?—A. About 50 of the linseed, 30 of the sesamé-cake, and 20 of bran.

Q. The linseed that you have used, was it Calcutta or Black Sea?—A. Both.

Q. How would you describe the linseed that you used in this cake; would you call it “genuine,” or “pure,” or what?—A. genuine linseed.

Q. Do you know the parties from whom you bought the linseed that was used in the manufacture of this cake?—A. Yes.

Q. Whom did you buy it from?—A. Messrs. Baxter and Tall of Hull—their invoices have been put in.

Q. Did you yourself see the linseed?—A. Yes.

Q. So as to speak from your own knowledge of the quality of the seed that was used in making this “Triangle Best”?—A. I did see it.

Q. And is that a sample of it which was marked “C” and produced to the witness yesterday in the bottle?—A. That is a sample of the Calcutta—the other is in my bag—“Calcutta linseed, *ex* ‘Labrador.’”

Q. We have there a fair sample of the Calcutta seed?—A. We have.

Q. And the other you produce?—A. This is a sample of the Black Sea (producing a sample)—the only sample I had, and by permission of the Court, I will break it open. I put it in on purpose.

Mr. Justice BLACKBURN: The linseed from which these samples are taken was that linseed which was used to make the particular lots of cakes in question?

Mr. SEYMOUR: Yes, that is what I asked him.

The WITNESS: The particular lot of cakes in question.

Q. Now, was that in any sense of the word dirty linseed?—

A. No one that knows linseed would say so for a moment.

Q. You say not?—A. Positively not.

Q. Was it a clear and genuine linseed?—A. Superior linseed; the best imported.

Q. I believe your contracts are in Court, and the vendors were bound that there was not more than 4 per cent. —

Mr. FIELD: You had better put them in if you are going to speak of them.

Mr. Justice BLACKBURN: The contracts—with whom?

Mr. SEYMOUR: With the parties who supplied this linseed.

(The documents were handed to the witness.)

Q. Were your vendors bound to supply you with linseed with not more than 4 per cent. of foreign elements in it?—A. They were bound to supply it.

Mr. FIELD: Let me see the document. (It was handed to the learned Counsel.) It had better be read.

Mr. Justice BLACKBURN: I suppose probably the jury will understand it.

The WITNESS: They are the trade contracts, used throughout England.

Mr. SEYMOUR: It is a very long document.

Mr. Justice BLACKBURN: I really don't know what it is.

[The ASSOCIATE read the contract.]

The WITNESS: That contract is signed by the brokers. Then, there is another.

Mr. SEYMOUR: It is a similar contract for the Calcutta seed?—A. Yes.

Q. Was this genuine linseed up to the standard of the Association in London?—A. Yes. I have the certificates of the Association, but I can give them from memory.

Q. You did get the certificates of the Association?—A. Yes, upon which the invoice was made out, and upon which I paid.

Q. Is that the document?—A. That is a certificate of the London Linseed Association.

Q. On which you paid for cargo?—A. On whose decision I paid.

Q. That being the certificate on which you paid, had a cargo of linseed been delivered at your Works before that certificate was obtained?—A. Oh, yes, in January.

Q. And I believe the Linseed Association are the association of the trade connected with linseed who have a fixed standard—that is to rule the prices and regulate the degree of purity of the linseed?—A. A joint committee of seed-crushers and merchants in linseed throughout the country.

Q. Was any of this linseed sea-damaged?—A. None.

Q. Was any of it mouldy that you used?—A. None.

Q. Now, I will ask you as to sesamé (a specimen was handed to the witness).

Mr. Justice BLACKBURN: Let us know how the 'sesamé was bought.

Mr. SEYMOUR: I am going to ask that, my Lord. (To the witness.) Where was the sesamé imported from?—A. From France.

Q. From whom was it bought?—A. Messrs. Young and Timm, of Hull.

Mr. Justice BLACKBURN: Was it bought in the shape of cake, or how?—A. Cake.

Mr. SEYMOUR: Did you personally see that sesamé-cake?—

A. I saw the whole of it.

Mr. Justice BLACKBURN: Give us the date of the purchase.

Mr. SEYMOUR: It was bought on the 7th of November.

Mr. FIELD: Have you got the contract?

Mr. ROBERTS: There is no contract—here is the invoice.

Mr. FIELD: Just let me see it. (It was handed to the learned Counsel.)

Mr. SEYMOUR: Have you used sesamé-cake largely?—A. I have.

Q. Can you yourself speak, from your own experience, of its use among cattle?—A. Yes, I use it at home.

Q. With your own cattle?—A. With my own cattle.

Q. Have you used portions of this sesamé-cake?—A. Yes, this identical sesamé.

Q. Beneficially?—A. Yes.

Q. As you say, you saw the whole of the sesamé, which was used for making this cake of which Mr. Wells got a portion?—

A. The whole of it.

Q. Was any of it mouldy or sea-damaged?—A. No, none.

Q. And the bran: was it a pure sound article?—A. Yes.

Q. Of whom was it bought?—A. Harker Brothers and Richard V. Knowles.

Q. Messrs. Harker Brothers' invoice is dated January 18th at 5s. 9d. per cwt. and the other is dated December 7th, bought of Richard Knowles at 5l. 15s. per ton. Is that the price of genuine bran?—A. A first-rate quality of bran.

Q. And was this equal to its price?—A. It was.

Q. Now have you told us the linseed, the sesamé, and the bran which you distinctly state was used in making the "Triangle Best" that was supplied to Mr. Wells?—A. I have—Calcutta linseed, *ex* 'Labrador;' Black Sea Sesamé, *ex* 'Result;' that is the name of the ship.

Q. And your books are in court?—A. Yes; we have the large books outside, but they can be produced.

Q. They are here to be examined to any extent?—A. I was ordered to produce them.

Q. What quantity of this "Triangle Best" have you sold, made in the form you have told us?

Mr. Justice BLACKBURN: Within what period?

Mr. SEYMOUR: Within the last two or three years, I will say?—

A. We have made it during the last four years. I made it, because the cake made from linseed so imported was so bad that there were complaints about it all over the country.

Q. On account of the impurities?—A. Yes; that led to the formation of the London and Provincial Linseed Association, so

that the buyers and crushers should have some standard by which they could receive or reject.

Q. What quantity have you made within the last four years of this "Triangle Best"?—A. More than 10,000 tons.

Q. And how much from these particular cargoes?—A. From the actual particular cargoes, these parcels of seed to which I am positively able to swear, between 275 and 280 tons. That I can positively affirm.

Q. The others, I understood you to say, were similar in quality?—A. Precisely. My engagement was to make them in that particular way, and I have never swerved from it.

Q. Of those 10,000 tons, including the number of tons made from this very article, have you ever had any complaint until you heard of the complaint made in this libel?—A. Not one.

Q. Now, would you just tell me shortly, if you please, the process by which you make your linseed cake?—A. My Lord and the gentlemen of the jury will pardon me if I am rather tedious in answering that question; but I must do it properly. The articles are in the mill —

Mr. Justice BLACKBURN: Which articles?—A. I will begin with the linseed. It is taken from the chambers, where it is passed over a screen for the "Triangle Best" cake, and run into hoppers, which are placed over our machinery; from the hopper the seed falls between rollers—heavy metal rollers, for the express purpose of breaking every grain of linseed, without which we cannot express the oil. No whole linseed goes into cake wittingly.

Q. Let us get one thing at a time. You pass it through rollers to express the oil?—A. Yes; no linseed is allowed to pass unbroken.

Q. One thing at a time, please. We are a long way from the cake yet. What else is done? I suppose the oil is taken away?—A. I have not got to the oil yet; there are two or three more processes. The linseed is broken by being passed through the rollers, and is then placed under the stones—"edge-stones" is the proper term. The two together weigh about ten tons.

Mr. SEYMOUR: And you have several pairs, I suppose?—A. Three large pairs. The fifty per cent. of linseed is put under the stones; to this is added the sesamé in the form of meal and the bran.

Mr. Justice BLACKBURN: They are put together under the stones, are they?—A. They are, my Lord. Those stones have an iron sweeper, which travels with the stones, and is so placed that it delivers all the linseed and sesamé and the bran under the stones. It is kept there from twelve to eighteen minutes, the stones continually revolving.

Mr. FIELD: The sweeper is kept there?

Mr. Justice BLACKBURN: No, the compound is kept there, as I understand it.

The WITNESS: At the expiration of that time a shuttle is opened in what we call "the calf,"—that is, an iron which surrounds the stones, and keeps the seeds from falling, and from there it is put into the steam-kettle.

Mr. Justice BLACKBURN: But what happens from that shuttle? I guess; but you have not told us what happens when you have opened the shuttle?—A. The seed is swept by this sweeper round on to this hole, and it drops on the ground, my Lord. From thence it is put into the kettles, which are surrounded by steam. They are double kettles—steam-kettles.

Mr. SEYMOUR: There is an upper and lower chamber?—A. There is an upper and lower chamber in each, and there are revolving arms to keep the seed continually moving. After remaining there, shuttles are opened, and bags are placed at the mouths of the openings to receive the seed—woollen bags. These bags are placed within wrappers, and put into the hydraulic presses, and subjected to a pressure of about 180 tons on each press. In consequence of that pressure the oil is forced through the sesamé and the bran, and runs out into a small cistern behind each press. This oil is then pumped into large cisterns, and stored for use. After remaining in these presses twelve or fifteen minutes, the pressure is removed, the wrappers withdrawn, and the cake is taken out. Boys take these pressed bags, strip off the bags, and the cake lies on a table ready for packing. These boys have knives in the shape of a half moon, and taking the cake in their hand, they pare first one side and then the other, and then the two ends. This is simply to prevent waste.

Q. And to give the cake a trim shape?—A. Yes, but the edges are so narrow that we should lose some of them. It is cut thus and thus (explaining), and so you see there are thick level edges, otherwise they would be all crumbling.

Q. What is done with the parings?—A. They are put back under the stones to be ground to powder; but those stones being edged stones do not always grind them to powder, but we put them in, being cake themselves.

Q. Are there sometimes small portions left in the cake?—A. Yes; if you will hand me a cake I will tell you if I see them. (A cake was handed to the witness.) Yes, I think there is one here; it is very slight. It is darker, and in a round patch. Those are the lumps from the parings.

Q. I was going to ask you this: we heard yesterday of something in a cake that had been analysed which looked like small substances that were agglutinated?—A. Yes; the whole secret

of that was, it was a paring that had not been ground to powder; it was simply the same as the cake itself—identically the same, nothing else.

Q. I only asked you that in passing. Now we have got the cake pared. Let us just finish the thing. Are they made, then?—

A. They are made and put into racks, because being hot they are not firm, and left to cool. Those racks hold two tons each, and there are six of them. When the racks are full, the boys, as they have leisure, or as the room is required for the fresh cake that is being made, bring a barrow, and put so many of the cakes out of the rack on to the barrow, and take it into the cake-house, weigh it, and pile it.

Q. And is it piled there in tiers ready for delivery?—A. Exactly; we begin with a big tier, and continue raising the cake with a series of steps. The cake is put indiscriminately there I have two mills divided by the engine, and there are so many cakes on one side of the engine, and so many cakes on the other. The cakes go from each mill indiscriminately, if we are making "Triangle Best," and are placed on that pile.

Now, with all these mixings, and changes, and counter-changes is it possible, in your opinion, for any poisonous element to be in one portion of the cake, and not to impregnate the whole?—

A. Impossible; if this had been poisonous, I should have fed my own cattle on a poisonous cake, because my cattle are fed on the "Triangle Best", which comes indiscriminately from the pile of which I have spoken.

Q. From which the rest is taken?—A. Yes.

Q. How many thousands of these cakes a day do you make?—

A. I think I am within bounds when I say 5000.

Q. That puts me in mind of a theory we heard yesterday from Professor Fairley. Have you ever made cake for the purpose of making it as cake, and not for the purpose of expressing oil from it in the legitimate course of your trade?—A. Never. In this book are entries for the last five years of the cake and oil made by every man in my employ, showing that the cake passes through the process which I have now described and the quantity of oil expressed from it.

Q. Is there a pretence for that suggestion?—A. It is perfectly contemptible.

Q. You say you have got a book there, showing all the cake made by every man. Have you the means of tracing each cake made in your establishment to the man who made it?—A. For fifteen years I have had but one holiday of a week's length.

Q. Mr. Justice BLACKBURN: That is not answering the question?—A. Every morning and every afternoon I am at the mill, and go in of course to see what is doing. I go into the cal

house and examine the piles of cake, and for this reason I can tell by the appearance of a cake whether it has been properly nipped. If it has not been properly nipped, oil has been left in it, to my loss.

Mr. Justice BLACKBURN: That, again, is not at all an answer to the question.

Mr. SEYMOUR: If in the course of your examination of the cake you find anything to object to in its form or character, or otherwise, are you able to trace the hands through which it went in process of manufacture?—*A.* I can trace the maker of that cake—the press-man who makes that cake.

Q. And have you ever sold a ton of cake as to which you cannot trace both the cake itself, its composition, and the man who pressed it, by your books and the mark of the cake itself?—*A.* They are all in my books.

Q. Do you use any cotton-cake in the manufacture of this linseed?—*A.* Never. Might I give a reason?

Mr. Justice BLACKBURN: The fact is what we want; attend to the material questions which are asked, and answer them.

Mr. SEYMOUR: First, you say “never”?—*A.* Not as adulteration—never.

Mr. FIELD: Not as adulteration?—*A.* I have sold cotton-cake and pressed cotton-cake.

Mr. SEYMOUR: But I ask you whether you have ever used cotton-cake as an ingredient, or mixed it in making your linseed-cake?—*A.* Never.

Q. Suppose you did, what would be the effect?—*A.* I should ruin the oil—any one knows that.

Q. You would ruin the quality of the linseed oil?—*A.* Directly.

Q. And the oil being more valuable, you would sacrifice the greater for the less?—*A.* That (producing a bottle) is the colour of cotton oil. That (producing another) is the colour of linseed oil. The consequence of putting even a few drops of the one into the other would be to ruin it, and I should have 2*l.* or 3*l.* a ton less for my linseed oil.

Q. Then is it of vital consequence to prevent such a thing, even by matter of accident?—*A.* Why, of course it is.

Q. Have you ever had either cocoa-nut or cocoa-nut fibre in your mill at any time to your knowledge?—*A.* I never heard of it. I learned more how cakes were made yesterday than ever I knew in my life.

Q. Then you say you do not know anything about such stuff?—*A.* I do not know it. I don't know what it is.

Q. What does the cake cost you per ton—this “Triangle Best”?—*A.* Out of my mill, delivered to Messrs. Ayre, Brothers' rolleys or boat, that cake cost me 9*l.* 5*s.* per ton.

Q. That you distinctly state?—*A.* I swear it.

Q. What is your profit?—*A.* I sold 2700 tons to Messrs. Ayre, Brothers at 9*l.* 10*s.*

Q. Leaving you a profit of 5*s.* per ton?—*A.* Yes.

Q. Have you ever allowed warehouse sweepings to be mixed with your cake?—*A.* I have never had them.

Q. Perhaps, as we have negatived some of these imputations, we had better ask the others—Rice husks?—*A.* Never.

Q. Or dodder, or darnel?—*A.* Except what comes in the seed.

Q. Except that which is covered by the 4 per cent.?—*A.* I have never bought anything to put into my linseed-cakes, into the “Triangle Best,” but sesamé—the best sesamé—and best bran, and never anything to put into the “Triangle Common” but bran and nut-cake.

Q. I believe the cake that went to Mr. Wells was sent direct from your own place?—*A.* I sent two tons on the day mentioned, according to Messrs. Ayre, Brothers’ orders.

Q. It went from you?—*A.* I believe it did. I do not dispute that.

Q. On the rolleys of the North-Eastern Railway Company?—*A.* Yes.

Q. It went from your place; it did not go to Messrs. Ayre, Brothers first?—*A.* No doubt of it.

Q. And was that taken indiscriminately from stock you had at the time?—*A.* Yes, out of 10 tons; I had from 10 to 12 tons in stock on that day.

Q. And that was taken indiscriminately from it?—*A.* Yes.

Q. Except the bran, which we have heard of, and except the sesamé, which you have stated is an element, does that cake contain more than the proportion of 4 per cent. which is allowed by the standard of foreign substances?—*A.* Five per cent.

Q. More than the standard allowance?—*A.* Just exactly as it is on that paper.

Q. There is nothing else in it?—*A.* Nothing else whatever.

Q. And the seed is screened?—*A.* Once screened.

Q. The “Triangle Best”?—*A.* Yes.

Q. After you got the certificate?—*A.* Oh, yes; but these samples were just as they were taken (pointing to the samples).

Q. Then that is unscreened (pointing to the seed samples)?—*A.* Unscreened.

Q. So that therefore the linseed used was purer than that?—*A.* Well, it would be a little.

Q. Before I sit down, I wish to have everything very clear. You have told us the distinction between ordinary and “Triangle Best” cake, but where is the distinction between what you call



genuine in the trade and pure? What is pure linseed?—*A.* This is a sample offered to me the morning I left Hull, to make genuine linseed-cake of.

Mr. Justice BLACKBURN: Is that genuine seed or genuine cake?—*A.* Genuine linseed, my Lord, as imported.

Mr. SEYMOUR: My question is, What is the distinction between "genuine" and "pure"?

Mr. Justice BLACKBURN: Is there a distinction—is there in commerce a linseed that is known as "genuine" linseed, and another known as "pure" linseed.—*A.* "Genuine" linseed is linseed as it leaves either the North of Russia, the South of Russia, or Calcutta—the linseed of which I make my "pure" cake —

*Q.* Do keep your attention upon what you are asked. Is there in commerce a known distinction between "pure" linseed and "genuine" linseed?—*A.* No, my Lord.

Mr. SEYMOUR: My question was as to cake.

Mr. Justice BLACKBURN: Then you must put it in a different way.

Mr. SEYMOUR: What are the ingredients of "pure" cake, as distinguished from "genuine"?—*A.* The genuine linseed, as imported, is screened four times, and the extraneous matter, as far as possible, taken out. In "genuine" cake it is left in, however bad the linseed may be.

*Q.* "As imported"?—*A.* As imported.

*Q.* And is the price of "pure" considerably higher than the other?—*A.* 25s. to 30s. above "Triangle Best."

Mr. Justice BLACKBURN: I suppose this circular would tell us?

Mr. SEYMOUR: Yes, it is at the top of "ordinary." (To the Witness) You sell the "pure" with a warranty?—*A.* Yes.

*Q.* You have a regular form of warranty that you use?—*A.* Yes, I believe there is one in Court.

*Cross-examined by Mr. FIELD.*

*Q.* Then you sell nothing to Messrs. Ayre, Brothers except "Triangle Best"?—*A.* Oh, yes, "Diamond K Pure"; and plain "Triangle."

*Q.* But in the circular that I have had handed to me, is your mark "A. C. Best"?—*A.* No.

*Q.* Whose mark is that?—*A.* It is another crusher's.

—*Q.* Whose is it?—*A.* Ayre and Chambers.

*Q.* The invoice that you have handed to me only contains "Triangle Best," "A. C. Best," and "A. C. Pure"?—*A.* The invoice?

Mr. Justice BLACKBURN: You mean the circular.

The WITNESS: If you look in the lower columns there are other marks.

Mr. Justice BLACKBURN: You will find these three, "Triangle Best," "A. C. Best," and "A. C. Pure," as if they were the more important, in bigger type, but there are a good many below it.

Mr. FIELD: What is the meaning of this "Ordinary Quality B."—is that your mark?—*A.* No.

Q. Is that Blundell's?—*A.* No, it is Messrs. Walker and Smith's.

Q. Then I do not find here any of your mark?—*A.* Oh, yes, "Diamond K Pure" will be in one of the columns.

Mr. SEYMOUR: You will find it there.

Mr. FIELD: Then under "Ordinary Quality," in this circular, here is what is called "Triangle Best"?—*A.* No.

Mr. SEYMOUR: You see this is the circular of Mr. Ayre. I will explain, when Mr. Ayre is called, why he puts the "Best" above it.

Mr. FIELD: Then "Triangle Best" is by itself—the words "Ordinary Quality" do not refer to the "Triangle Best" at all?—*A.* Well, that is not my circular.

Q. I am perfectly aware of that, but you have put it in evidence?—*A.* That does not refer to the "Triangle Best," nor to the "Genuine."

Q. Then neither of them refers to the headings—those are articles of themselves, "Triangle Best," "Triangle A. C. Best," and "Triangle Pure"?—*A.* Yes.

Mr. Justice BLACKBURN: But is not "Triangle Best" one of your marks?—*A.* It is, my Lord.

Mr. FIELD: And under the "Ordinary Quality," "Triangle" is your mark?—*A.* It is.

Q. That is what you have called in words "Triangle Common"?—*A.* "Plain Triangle" is the usual term.

Q. But there is nothing but a triangle to mark that?—*A.* Nothing but a triangle.

Q. Now, you have not told us the composition of the "Triangle"?—*A.* Yes, nut-cake, bran, and linseed.

Q. That is the "Triangle Common"?—*A.* Yes.

Q. What is nut-cake?—*A.* It is imported from France.

Q. What is it?—*A.* It is the cake produced by crushing ground-nuts.

Q. What nuts?—*A.* Ground-nuts.

Q. What do you mean by that?—*A.* I do not know.

Q. What sort of nuts do you mean?—*A.* Imported from Africa, I believe, into France.

Q. What nuts are they?—*A.* Earth-nuts.

Q. What! nuts that grow in the earth? I do not understand what you mean.—A. Well, I really have not seen them growing.

Q. I do not suppose you have; but you can tell me what the earth-nut is, the cake of which you make into linseed cake?—

A. It is a nut imported into France from Africa, the oil of which, I believe, fetches a good price, but not the price of sesamé-oil.

Q. Is it a nut to eat, or what?—A. Do not you know the earth-nut of England?

Q. No.—A. Oh!

Mr. FIELD: Well, do not despise me for not knowing it.

Mr. Justice BLACKBURN: Is the earth-nut of England what I have been in the habit of calling a “pig-nut”—a white, round thing, with a long slender stem, and a leaf at the top, which, when I was a boy, I used to dig up and eat?—A. I suppose it is, my Lord.

Mr. FIELD: Then it is a nut which is grown in the earth, and sent from Africa to France?—A. Yes.

Q. And it is made into cake in France?—A. Yes.

Q. And then imported here?—A. Yes.

Q. What percentage of earth-nut is there in the “Triangle,” what of bran, and what of linseed?—A. There would be 50 per cent. of bran—it is principally bran—20 per cent. of nut-cake, and 30 per cent. of seed.

Q. Seventy per cent. of matters other than linseed?—A. Yes, at a lower price.

Q. As I understand, your “Triangle” is made at the same rolls and hoppers as your “Triangle Best.”—A. Yes.

Q. Professor Voelcker tells us that he found earth-nut in the “Triangle Best;” is that so?—A. No.

Q. Mr. Justice BLACKBURN: I do not recollect that he said so.

Mr. FIELD: Cocoa-nut cake?—A. I never saw it.

Q. Will you tell me, please, when was it that you made this agreement with Mr. Ayre that you refer to in your letter of March: “Those cakes having been made entirely in accordance with the agreement made between ourselves, viz., of linseed, sesamé-cake, and bran”—was that agreement in writing?—A. No.

Q. When was it made?—A. About four years ago, when those cakes were first instituted. I could tell by looking back.

Q. When you speak of the price being 9*l.* 10*s.*, is that for forward contracts?—A. Yes, present and forward, as the case may be.

Q. First of all with regard to the Calcutta seed *ex* ‘Labrador,’ have your invoice here from Baxter and Tall’s, of the 19th December, 1871?—A. Yes.

Q. That, I understand you to say, is the linseed from which this cake was made?—A. It is.

Q. Have you any book here which will show me when this stock of linseed was exhausted?—A. No, I do not think I have one.

Q. Do not you keep a stock-book which will show you when you got this quantity in?—A. I have one which contains all the arrivals of the linseed.

Q. Pray answer the question, have you any book which will show me the disposition of this quantity, *ex* 'Labrador'?—A. No, I have not.

Q. Or, I suppose, of the other ship, the 'Varina'—you have no book which will show me what became of it?—A. Yes, I can show you that it went to the mill.

Q. But at what date did it go?

Mr. Justice BLACKBURN: That is what is wanted to be known, when did the last go to the mill; if your book will tell us that, we should like to know?—A. I will get the book.

Mr. SEYMOUR: We have got a cart-load here.

Mr. Justice BLACKBURN: First ascertain what book it is that is wanted. As I understand, you keep some book or other at your mill which will show you when the linseed goes into the mill?—A. Yes.

Q. Have you got that book here?—A. Yes.

Q. Is it the one in your hand?—A. No.

Q. Then we will now adjourn for a short time, and you will have an opportunity of finding the book which will show that.

(Adjourned for half an hour.)

Mr. FIELD: I was asking you, Mr. Kidd, if you had a book which would show me when the linseed *ex* 'Labrador' was first carried into the mill?—A. Yes.

Q. Will you turn to the page—do not give me the book—and say what is the first date, reading from that book, that Calcutta linseed, *ex* 'Labrador,' went into the mill?—A. December 29th, 1871, 575 bags, containing 323 qrs.

Q. Is that all?

Mr. Justice BLACKBURN: Give us the last?—A. January 10th, 3050 qrs.

Mr. FIELD: Now, can you tell me from your books when that went out of the mill. I mean were there deliveries intermediate into the mill between those two dates?—A. The total quantity *ex* 'Labrador' is 5223 and 2402 bags; that is something like 8000 bags; to be exact, 7625.

Q. During what period did that go into the mill?—A. From the 29th of September to the 29th January.

Q. In like manner, with reference to the linseed which came *ex* 'Varina,' give us the first and last date?—A. The 22nd January is the first date, and the 1st February is the last date.

Q. You have got there your delivery-book?—A. Of cake?

Q. Yes?—A. Yes.

Q. Turn to your delivery-book under date February 13th?—  
A. Yes.

Q. You have on that day two deliveries of 2 tons of cake, was not the 13th the date on which you delivered those 2 tons in question?—A. Yes.

Q. Which of those 2 tons are the 2 tons in question?—A. Ayre, Brothers, 2810.

Q. What do you say?—A. Well, I delivered that to the Railway.

Q. What does 2810 represent?—A. Two tons of "Triangle Best."

Q. No, no; what does the number 2810 represent?—A. The number of Ayre, Brothers' order.

Q. Now please to give me Ayre, Brothers' order, No. 2810 (it was handed to the learned Counsel); very well, that seems to be so, 2810 represents that. Now tell me what book you have which will show who it was who made those 2 tons of cake?—

A. I can tell you who made the "Triangle Best," but I cannot tell you who made that 2 tons, because it might come out of the pile indiscriminately.

Q. Let me ask the question, are "Triangle Best" and "Common Triangle" mixed together?—A. Oh, no, they are all separately piled, if you mean that.

Q. Why cannot you tell me who made the "Triangle Best"?—A. I can as to the bulk.

Q. Who made the bulk of the "Triangle Best," of which these 2 tons, as you say, formed part?—A. Smales and Lockham; Middleton and Stevenson are the foremen.

Q. Is Smales the parer?—A. No, the press-man.

Q. Who is the other, Lockham; is he a press-man, or a parer, or a grinder?—A. A press-man.

Q. What is the other man's name?—A. Middleton.

Q. What is he?—A. A press-man.

Q. Are they all press-men?—A. Yes, I have no names of the parers-down.

Q. Those are press-men, and their duty, if I understand it right, is to take the linseed from the steam-kettle, put it into the bags, and put it under the hydraulic press?—A. Yes; but in addition to that, Smales is the press foreman, and has to see that the orders of the mill are carried out as he receives them from the foreman; he is the inside foreman.

Q. Has he the superintending of the parers and grinders?—  
A. Yes.

Q. I suppose we shall see him here?—A. Yes.

Q. And shall we see any of the press-men here?—A. No; he is a press-man as well; I did not bring any of the others.

Q. Who was the parer who had to pare the cakes?—A. I do not know the boys.

Q. Who is the grinder?—A. I do not know; the men obey the orders of the foreman, and the foreman —

Q. You have your foreman here, I suppose?—A. Yes.

Q. Has he charge of the whole mill?—A. The whole mill.

Q. Under you?—A. Under me.

Q. You say a portion of this *ex* 'Labrador' was taken into the mill on some day in January?—A. The first was on the 29th December.

Mr. Justice BLACKBURN: The last day was the 10th January.

Mr. FIELD: Can you tell me when the last of that linseed went out of the mill?—A. That I cannot tell. I can tell what was in the mill when the news came that Mr. Wells' cow died. I went to the mill to see.

Q. How do you mean?—A. What seed—I wanted to know.

Q. Was any of that seed left then?—A. Yes.

Q. How much?—A. I see I ordered some more Calcutta in on the 21st, so that that Calcutta would last until the 20th at the least.

Q. I do not follow your reasoning?—A. I find that I ordered some more on the 21st February, so I must have been about run out.

Q. That leads me to ask you, after you purchased *ex* 'Labrador,' and before the 16th February, did you buy any other linseed, either Black Sea or Calcutta?—A. That had been bought before, but arrived during the time.

Q. Of whom did you buy that?—A. Baxter and Tall.

Q. When did that arrive?—On the 30th January—395 qrs. from the 'D. M. Parke.'

Q. Did you buy any other besides intermediately between those dates?—A. There is some *ex* 'Escolta'—690 qrs. Black Sea—not Calcutta.

Q. Any more besides?—None.

Q. What became of the linseeds that arrived by those ships. Are they all put together in one common warehouse?—A. No, the 690 qrs., of which I have a sample, was especially good, and bought to make pure cake of.

Mr. Justice BLACKBURN: You say there was some *ex* the 'D. M. Parke' arrived on the 30th January—did that go into your mill or not?—A. I am giving the dates of the arrival at the mill. I thought that was what you required.

Mr. FIELD: I should like to have the account of all that came into the mill between the arrival of the 'Labrador' and the 16th

February. What other linseeds had you in the mill between those dates?—*A.* Up to the 20th or the 16th?

*Q.* The 16th February?—*A.* Nothing but the 626 Riga linseed.

*Mr. Justice BLACKBURN:* The important date would surely be the 13th February, when the linseed-cake in question started. We do not care about anything that happened after that, at all events.

*Mr. FIELD:* That is so; the 13th is the important date. In what part of the warehouse are your linseeds stored?—*A.* On two floors.

*Q.* Are they all put together?—*A.* No.

*Q.* They are shot in heaps?—*A.* In heaps.

*Q.* As soon as the bags arrive?—*A.* Yes.

*Q.* Are the heaps kept separate?—*A.* Yes, if the qualities are different.

*Q.* Are they shot together?—*A.* The Calcutta are kept separate from the Black Sea always.

*Q.* Then the other cargoes that came in of the Calcutta, they would be shot together with the *ex* 'Labrador'?—*A.* There was none came in from the 21st February.

*Mr. Justice BLACKBURN:* But I understood there was a considerable quantity of Calcutta linseed arrived on the 30th January?—*A.* It was Black Sea.

*Mr. Justice BLACKBURN:* Then I have taken it down wrong. I understood you to say it was Calcutta?—*A.* Only 329 qrs.

*Q.* Was it Calcutta or Black Sea?—*A.* Black Sea.

*Q.* Then I made a mistake. I thought you said there was more Calcutta arrived before the 13th February?—*A.* No, on the 21st that arrived—that is the one we are talking of.

*Mr. FIELD:* Answer me this. Was there no Calcutta linseed between the arrival *ex* 'Labrador' and the 13th February?—*A.* None.

*Q.* And the Black Sea linseed that arrived was 395 tons?—*A.* 395 qrs. from the 'D. M. Parke.'

*Q.* And that was shot together with the linseed *ex* 'Varina'?—*A.* Well, I thought so, and therefore I produce the invoices.

*Q.* You have done so?—*A.* Yes.

*Q.* Just refer to the invoice *ex* 'Varina,' and tell me have you got the difference account which was rendered to you *ex* 'Varina'?—*A.* Yes, it is 1.58 (handing a document to Mr. Field).

*Q.* I see the total purchase of linseed *ex* 'Varina' was 2266 qrs.—*A.* It was.

*Q.* And the allowance was upon 1173 qrs. (handing the document to the Witness). Just look at the invoice, and tell me

the meaning of this, which I see here at the bottom, "Difference account to be rendered afterwards"?—*A.* I know it by heart.

*Mr. Justice BLACKBURN:* Then let me see it, for I confess I do not. (It was handed to the Court.)

*Q.* What is the difference between the 1173 qrs. upon which there was a difference to be rendered and the total bulk?—*A.* The total cargo was 3443 qrs.; I received at the mill 2206 qrs., and re-sold 1176; and the difference is either a loss I made on that sale or a profit.

*Mr. FIELD:* That is the difference account?—*A.* Yes; that is not a difference of quality; that is the difference in price of the re-sold which is at the bottom of that invoice.

*Mr. Justice BLACKBURN:* Then all that comes to nothing as far as regards the present case.

*Mr. Field:* I only want to understand it. What is "allowance to buyers *ex* 'Varina' of 2½ per cent."?—*A.* 1·58, is not it.

*Q.* What is the meaning of that?—*A.* That is 1½ per cent.

*Q.* What for?—*A.* Because it had more seeds in it than the 4 per cent., which is the standard for pure linseed. Therefore they allowed me that because it was dirtier than pure.

*Q.* What was the allowance account on the 'Labrador'?—*A.* It was clean, and I had to pay extra price, because it was less than the 4 per cent.

*Mr. SEYMOUR:* The linseed by the 'Labrador'?—*A.* Yes, I had to receive on the 'Varina,' and pay on the 'Labrador.'

*Mr. FIELD:* That was what I did not quite understand. I understand you to say that there are three kinds manufactured?—*A.* Yes.

*Q.* What you call linseed pure?—*A.* "Diamond K Pure."

*Q.* Marked "Diamond K"?—*A.* Yes.

*Q.* Linseed genuine?—*A.* No.

*Q.* What is it, then?—*A.* "Triangle Best," not "Linseed best."

*Q.* "Triangle Best" linseed, is not it?

*Mr. Justice BLACKBURN:* The cakes have the marks upon them "Triangle Best" merely. It does not say whether it is linseed or not.

*Mr. FIELD.* It is "Triangle Best" linseed-cake. You see this circular of Messrs. Ayre, "Triangle Best Linseed"?—*A.* No.

*Q.* You do not adopt that?—*A.* No.

*Mr. Justice BLACKBURN:* There was something that *Mr. Seymour* wanted to have the circular brought in for, and you objected to it. If you both wanted it in, let it be put in, with all my heart. What is this that you are now showing to the Witness (the circular was handed to the Court); you may ask anything about it that you wish.



Mr. FIELD: That is the heading "Triangle Best Linseed Cakes"?—*A.* It is.

Q. And that is not what you sold to Mr. Ayre?—*A.* Yes. I sold "Triangle Best Linseed Cakes."

Q. You did sell "Triangle Best Linseed Cakes"?—*A.* Yes.

Q. Composed of bran and sesamé to the extent of 50 per cent.—*A.* Yes; and better than linseed-cake.

Q. I am not asking you that—my question is, do you call that "Triangle Best Linseed Cake"?—*A.* No. "Triangle Best Linseed Cake."

Q. Then you do?—*A.* Yes.

Q. Composed one half of sesamé and bran?—*A.* Yes.

Q. And you mean to represent that that was known to the world when you were selling "Triangle Best Linseed Cake"?—*A.* It was known to all my buyers.

Mr. Justice BLACKBURN: I understood (it must have been a mistake of mine) that you had a contract with Messrs. Ayre, by which they were your sole buyers?—*A.* With the exception of some private customers.

Mr. FIELD: Did you sell this to anybody but Mr. Ayre?—*A.* A few tons.

Q. To whom?—*A.* Richard V. Knowles.

Q. When?—*A.* During the season.

Q. When?—*A.* From October to this March.

Q. About what quantity?—*A.* Fifty or sixty, or seventy tons.

Q. Anybody else?—*A.* No.

Q. Then all that you will say is, that it was known to Knowles and Ayre, that your "Triangle Best Linseed Cake" consists of linseed, sesamé, and bran?—*A.* One or two customers of mine.

Q. Give me their names?—*A.* Thomas Irving, of Chesterfield.

Q. What is he?—*A.* He is a large cake dealer.

Q. In the trade?—*A.* Yes; and Mrs. Miller, of Thirsk.

Q. In the trade?—*A.* Yes. I do not know anybody else.

Q. Nobody else? Because I should like to have some of this cake by and by, if I could get it?—*A.* There is a quantity of it.

Q. Who else knew of it?—*A.* I think that is all.

Q. Can you tell me what quantity of tons have been sold of that "Triangle Best"?—*A.* About thirty tons.

Mr. Justice BLACKBURN: Thirty to each, or thirty to the whole?—*A.* I should think thirty to the whole.

Mr. FIELD: Have you got a book, which will show your deliveries to the first name that you mentioned—Mr. Knowles; have you got a book or an invoice?—*A.* This is the counterfoil of the invoice-book.

Q. Then, what you mean to say is, that these persons knew what you were selling.—*A.* Oh, decidedly so.

Q. What do you call “Linseed pure”?—*A.* “Diamond K.”

Q. Where is the mark? Have you got a copy of the mark here?—*A.* It is on that cake, and it is on the circulars too.”

Mr. FIELD: I see here “Diamond K Ditto”?

Mr. Justice BLACKBURN: The pure is above; but if you will look at the cake you will see the mark, and it will enable you to understand it.

Mr. FIELD: It is very difficult to see?—*A.* Well, the workmen darn the brands on to our bags, and are paid for it.

Mr. Justice BLACKBURN: I suppose there is a diamond with a K inside of the diamond, and then the word “pure” after that?

Mr. FIELD: Well, I take it in faith, for I cannot see it.

Mr. SEYMOUR: I see it.

Mr. FIELD: You see it with your client’s eyes.

Mr. SEYMOUR: Thank you. I see it also with my own; it is written backwards.

Mr. Justice BLACKBURN: Yes, from its having been put on the bags, the letters are reversed.—*A.* When we rip the bags we turn them inside out.

Mr. FIELD: Give me a cake of the ordinary, that is the cake I like best.

Mr. Justice BLACKBURN: If the gentlemen of the jury wish to look at it, they will see there is “Diamond pure,” only from the bag having been turned the wrong way, the letters are reversed. Therefore it is something like (if you have read ‘Alice in Wonderland’) seeing the Jabberwock written the wrong way.

Mr. FIELD: I cannot see it.

The WITNESS: Oh, Mr. Field!

Mr. FIELD: Do not be angry with me.

The WITNESS: It is right in the middle of the cake.

Mr. Justice BLACKBURN: You will see it is “Diamond pure,” only with the letters turned the wrong way. If you were to hold it opposite a looking-glass you would see it quite right.

Mr. FIELD: It is a difficult operation to see it. What is this (pointing to a mark on the cake)?—*A.* That is a darn, because the bag was torn.

Q. What is this other mark?—*A.* That is the man’s mark.

Q. Whose mark?—*A.* The maker; so that if he makes it badly, I know who has done it.

Q. Does that indicate to you what his name is?—*A.* My foreman will tell you that.

Q. What you call “Linseed pure” is linseed with the seeds—which are supposed to be grown with it—screened from it?—*A.* As far as possible.

Q. By four screenings and siftings?—*A.* Yes.

Q. Where is it that the screening is done?—*A.* It is done as the linseed comes in, first of all to take away the matting and straw.

Mr. Justice BLACKBURN: That is not what you were asked. It was, Where is it done?—*A.* At the mill.

Mr. FIELD: What part of the mill is it that the screening and sifting is done?—*A.* The first screening is at the entrance from the river.

Q. On the first, or ground floor?—*A.* Ground floor.

Q. What is taken out by the first screening?—*A.* The seed goes through in the first screening, and leaves matting, and bits of chip, and so on.

Q. That is a coarse screening?—*A.* Yes.

Q. What is the size of the mesh of the riddle?—*A.* Well, I may tell you that all seed, for whatever kind of cake it may be, goes through that riddle.

Q. Therefore there is not much in that?—*A.* No, it is to prevent bits of bag from getting through, and so on.

Q. Where does the next take place?—*A.* The elevators take the seed up to the top of the mill.

Q. But I suppose it is discharged from its bags on the ground floor?—*A.* Yes, or in the lighter.

Q. In what shape, then, is it taken up to the top of the mill?—*A.* In a state of nature.

Q. In what bags?—*A.* In buckets.

Q. Then it is taken up there with all its seeds in it, polygonaums or drunken darnels, or whatever there may be in it, all goes up there?—*A.* Yes, if there are any.

Q. Is there any seed that comes from the Black Sea without them?—*A.* I do not think there were any in one of the samples.

Q. Where did that come from?—*A.* From the Black Sea.

Q. What, without any admixture?—*A.* Well, 4 per cent. is scarcely discernible.

Q. Then the Calcutta is not so clean as the Black Sea?—*A.* It was cleaner in this instance.

Q. But as a rule it is not?—Yes, I should think it is now.

Q. What is the real percentage of seeds in the Calcutta linseed?—*A.* I should think about 5 per cent. is the average.

Q. Then with the seed, whatever there may be in it, it goes up to the top of the mill?—*A.* Yes.

Q. Do all the siftings go on up there, the three further siftings?—*A.* Yes.

Q. What is the size of the smallest mesh that is used for sifting?—*A.* Well, I cannot tell you the size; there is one

which is a sand screen to take out the sand, and there is another which is larger, and one smaller.

Q. What is the position of the place where these siftings and screenings go on with reference to the place where the cake is made?—A. Oh, it is a long way off; one is at the top and the other at the bottom of the mill.

Q. How many floors are there between?—A. Two.

Q. How is the linseed, which, according to your account, is taken from the bottom floor to the top, conveyed there?—A. By elevators; it is taken through the screens and into the hoppers.

Q. What becomes of the screenings and siftings?—A. The sand is thrown away.

Q. What becomes of the screenings and siftings?—The rubbish is thrown into the river, which is part of the screenings and siftings.

Q. What part of the screenings and siftings is thrown into the river?—A. The sand and dirt and lumps, and such like things.

Q. They are taken out at the bottom?—A. No. The sand is taken out at the top.

The dirt and the lumps come out at the bottom?—A. Yes.

Q. What becomes of the rest of the screenings and siftings, such as dodder and rape?—A. If we have anything but fine linseed in the mill it is used for the common cake.

Q. Then the screenings and siftings which come out of the linseed are used for the common cake?—A. If it is being made with fine seed.

Q. If it is not fine?—A. It is not put in.

Q. What becomes of it then?—A. It lies there till we use fine seed for the common cake.

Q. I do not follow you—let me try to understand you: you have linseed containing things that you wish to separate from it, which I call screenings and siftings—it is a phrase known in the trade?—A. I do not know.

Q. Do not blush—are not there cakes which are known as siftings cake?—A. No, not to my knowledge.

Q. You never heard of them?—A. No, I am speaking what I believe to be the truth.

Q. You never heard of siftings cake?—A. No, never.

Q. Now, as to the result of this screening, tell me what becomes of it—where is it carried to from the top floor?—A. The screenings are lodged in bags, fastened in a proper way, and they are put on one side; the sand and the dirt is thrown away, and these other siftings that we have paid for as seed, go in with fine linseed if we are compelled to use fine linseed in making cakes at 25 per cent. below the price of pure.

Q. Then you use the screenings and siftings mixed with pure seed to make cake?—A. Yes, the screenings.

Q. The screenings are put into bags?—A. Yes.

Q. Where are they carried to from the top floor after they are put into bags?—A. The foreman will tell you that.

Q. Give me some notion?—A. They are kept at the top, I should think.

Q. They are not mixed up with the linseed at the top?—A. I do not know how it is done—I do not know at what exact place; I should say at the hopper.

Q. Then you mix it with the fine linseed, do you?—A. For the common cake.

Q. I do not want to know that; what I want to know is this: is it put with the fine linseed in the top of the warehouse or the bottom?—A. It is put by itself, and then if we have common cake to make out of the fine linseed, we put a certain proportion to it to make it equal to linseed “genuine as imported.” That is used and sold for genuine cakes—not by me.

Q. These screenings are put with fine linseed to make common cake of?—A. That being equal to the common cake which is made in Hull.

Q. But you do not mean to say that it is equal to good common cake?—A. Yes, it is.

Q. With these siftings?—A. Quite equal.

Q. Who has the duty in your mill of mixing the screenings with the fine linseed?—A. It is the foreman’s duty.

Q. And we are going to see him?—A. Yes.

Q. But as I understand it, the mixing takes place upstairs?—A. Yes.

Q. Are not the screenings sometimes brought down into the lower floor before they are mixed?—A. No, they are not.

Q. Never?—A. Never.

Q. There never was such a thing?—A. There never was such a thing.

Q. In order to understand this, let me ask you this—If I understand rightly, what is called pure linseed is first of all put into the hopper and ground or crushed?—A. Rolled.

Q. The object of that is not to get out the oil, but to prepare the seed for the ultimate pressure of the oil out of it?—A. Exactly.

Q. Therefore that is a slight operation; it is merely, in fact, bruising the seed?—A. “Cracking,” as we call it; it cracks the husk.

Q. Then, I now ask you this, with reference to the “genuine,” as you call it,—Is the only difference between that and the

“pure” that the wild seeds are not sifted from it?—*A.* It is not sifted—not the last sieve.

*Q.* The “genuine”?—*A.* No, not the last sieve.

*Q.* What we have here is a compound cake?—*A.* Yes.

*Q.* That is called “Buffum”?—*A.* No, I do not call it so.

*Q.* You do not, I know; but is not that the word used for these cakes?—*A.* No, not for “Triangle” cakes.

*Mr. Justice BLACKBURN:* Is the word used for any cakes?—*A.* It is a vulgar phrase used by the men.

*Mr. FIELD:* And what do the men of Hull mean by it? Do not they mean compound cakes? Is not it a common term to use for mixed cakes?—*A.* No, I have heard the word before; but it is used to denote what is mixed with it, not the cake after it is made

*Q.* What is that?—*A.* Bran.

*Q.* Then your “Triangle Best” is Buffum—it has got bran in it?—*A.* Yes.

*Q.* What is the meaning of Buffum?—*A.* I do not know. It is what I should call a vulgar slang word.

*Q.* Is not there special machinery for making these compound cakes?—*A.* No.

*Q.* Have you any of Thompson and Stather’s machinery?—*A.* Yes.

*Q.* Is not that machinery expressly made for the purpose of producing these compound, or, as I call them, “adulterated” cakes?—*A.* It has nothing to do with the making of the cakes; it could not make them.

*Q.* Is the object of it to grind more closely than the ordinary machinery?—*A.* To do it more quickly.

*Q.* I want you to explain this to me. When you make what I call a compound cake—I suppose I may call it a compound cake?—*A.* You are at liberty to call it what you like.

*Q.* And you will not object?

*Mr. SEYMOUR:* As long as you do not forget it is “Triangle Best.”

*Mr. FIELD:* A mixed cake?—*A.* Yes.

*Q.* When you make a mixed cake, do not you first of all crush the sesamé or the other materials that are put in—say earth-nut?—*A.* Nut-cake.

*Q.* You crush that, do not you, at the rolls first?—*A.* No, the machine does that. That is what the machine is for—to break the cake.

*Q.* You mean this Thompson and Stather’s machine?—*A.* Yes, with revolving arms.

*Q.* You crush that at the rolls first, do not you?—*A.* No, it

goes to the machine first, it does not go to the mill at all—it is not done by the rolls.

Q. Where is that done?—A. Just in one of the parts of the mill.

Q. By a separate machine?—A. Oh, quite, and worked by a separate engine.

Q. Then the sesamé cake is crushed up first of all by a separate engine?—A. Broken.

Q. And when it is so broken, is it placed under the rolls in the machine which ordinarily makes the linseed-cake?—A. Under the pair of edge-stones.

Q. Is not the linseed that is going to be used for the purpose of making the mixed cake passed through the rolls in the same way as the other, but much more lightly?—A. Oh, no; it is not the same machinery at all. One is a pair of rolls in which the seed is nipped, the other is a small piece of iron which holds the cake, and which has teeth to take the cake down and break it. It falls into a place where there are revolving arms, and those arms beat the cake to powder; it is then taken by little hoppers which pass it into a sifter, and any little bits of straw or stick which there may be in the sesamé-cake are not put into the meal, which is delivered as clean as it can be made.

Q. In what process is it that the sesamé and bran come together?—A. After the linseed is put through the rolls and is put under the stones. When the linseed is put under the stones the sesamé and the bran are added under the stones.

Q. And then you give just a slight —?—A. Oh, no.

Q. Now stop; just hear my question. Do not you give just a slight turn or two just to amalgamate those three things together?—A. No; we do not.

Mr. Justice BLACKBURN: If I understood the description before rightly, the object of the iron arm or sweeper which pushes them all under the stones, was to push them all under the stones together?

A JUROR: It is so. (To the Witness.) How long are they here?—A. They are twelve to fifteen minutes.

Mr. Justice BLACKBURN: If I understand you aright, they are put under the stones, and that being under the stones they all mix together?—A. Of course.

Mr. Justice BLACKBURN: The three things together are mixed under the stones.

Mr. FIELD: I ask you whether you do not make this difference, that you do not press out the oil so much in the rolls when you are going to make a mixed cake as you do when you are making a pure cake?—A. If I did not, I should be ready for an asylum.

Mr. Justice BLACKBURN: There is something in your question which shows that either you or I must have mistaken the evidence. I have understood that the oil was not pressed out at all till after they had been crushed?

Mr. FIELD: No; "bruised" is the word I used.

The WITNESS: "Grind" is the word.

Mr. FIELD: Do not you grind or bruise it?—*A.* No; "grind" is the word—cut it up.

Mr. Justice BLACKBURN: Are you speaking of what you do between the rollers?—*A.* Under the stones.

Mr. Justice BLACKBURN: Aye, aye; but the question and answer must be understood in order to get at the truth. Now let us hear your question, Mr. Field.

Mr. FIELD: I ask you this: when you are making pure linseed-cake do you merely bruise the seed?—*A.* Yes; as I said before, we call it "cracking" it.

*Q.* And then the stones grind it to a fine powder?—*A.* Yes; not to too fine a powder.

*Q.* Now, I will ask you this: when the "genuine" is made or the mixed cake, is not the pressure in the rolls less than it is when you are going to make a pure cake?—*A.* No.

*Q.* Do not you purposely leave larger seeds and more oil in the seeds when you are going to make mixed cake than when you are going to make pure cake?—*A.* No; it would annihilate my purpose if I did.

*Q.* That depends upon what your purpose is: if it is to sell oil, I agree; but if it is to sell cake, or if it is to sell bran for linseed, I do not agree?—*A.* If I wanted to disguise what I put into the cakes, I could grind it for half an hour to three-quarters—the more I grind it the less it would show.

Mr. Justice BLACKBURN: Now just let me see if I have distinctly understood—I will finish what I have written down, and then I will ask you if I have understood you rightly. Correct me if am wrong; but what I have understood you to say is, that there is no difference in the pressure of the rollers whether the cracked seed is intended to be used for pure cake or mixed?—*A.* None at all—none whatever.

Mr. FIELD: Is there not a difference in the grinding stones—is there not less grinding and crushing of the seed in the stones when you are making mixed cake than there is when it is for pure cake?—*A.* No; not perhaps above a minute or two.

*Q.* Well, then, there is a difference?—*A.* Well, I do not like my pure cakes ground much at all. I leave them as long as I can get the oil out, but I do not want to have them ground at all.

*Q.* There is a difference, however, in the extent to which the



compound material is ground and the pure linseed?—*A.* Very little.

*Q.* But there is?—*A.* Well, perhaps a minute or two; I do not know. We grind it so as to get it ready for the kettles.

*Q.* Is not that called “peppering”?—*A.* No; I have never heard the term in my life.

*Mr. Justice BLACKBURN:* Does it take more grinding for pure than for mixed, or *vice versâ*?

*Mr. FIELD:* More when it is going to be manufactured into pure.

*Mr. Justice BLACKBURN:* I understand just the contrary.

*The WITNESS:* No; not more one than the other.

*A JUROR:* Are there not fewer turns of the stones when it is for pure than for mixed?—*A.* Not one.

*Mr. Justice BLACKBURN:* I thought you said there was a difference in the time taken in grinding?

*The WITNESS:* Mr. Field says under the rolls.

*A JUROR:* You confound each other.

*Mr. Justice BLACKBURN:* Do I understand from you that when you have put the linseed under the stones, if it is for mixed cake there is a difference in the quantity of grinding, the number of turns of the stones, from what there would be if it was pure linseed?—*A.* Very little.

*Mr. FIELD:* Then there is some?—*A.* Yes.

*Q.* Is that “some” more or less—which takes the longest time?—*A.* Calcutta requires more grinding than the Black Sea.

*Mr. Justice BLACKBURN:* I have understood you just now, if I took you rightly, that when you are going to grind linseed without putting anything into it, you grind it for such and such time; and that if to that same linseed you were adding this bran and sesamé, you would grind it for a different time, is that so?—*A.* For about two minutes.

*Q.* Would those two minutes be more or less when you add the sesamé and bran?—*A.* Less when I add the sesamé. It is very material—two minutes!

*Mr. Justice BLACKBURN:* That may be—that is Mr. Field’s book out. But what I want to see is that you understand each other.

*Mr. FIELD:* Now is not the object of administering less grinding to the compound materials than to the pure this, that is merely for the purpose of mixing the three together, and not for the purpose of grinding for oil?—*A.* No.

*Q.* Then what is the object?—*A.* Simply on account of the cake. If I wanted to disguise the bran, as I said before, I should keep it in three-quarters of an hour, and Dr. Voelcker would have no more found out the bran than he found out the

sesamé that I put in that sample. I can grind it to a perfect powder, but I did not do so, and because I did not do so —

Mr. FIELD: With a good grinding you could grind and reduce everything in the cake to a perfect powder, so that nobody could discover what was in it?—*A.* Yes; but I never did it.

Q. But it may be done?—*A.* If it is kept long enough.

Q. So that no one can discover what it is?—*A.* Yes; grind it to flour.

Q. Now, Dr. Voelcker tells us of chenopodium seeds, and wild mustard, and clover, and so on—are those seeds ordinarily found in the Black Sea or Calcutta linseed?—*A.* Well, I do not know them by their botanical names, but I suppose they are.

Q. He says, besides those, he found cotton-seeds?

Mr. SEYMOUR: Cotton-cake?

The WITNESS: I most positively deny it.

Mr. FIELD: You deny it?—*A.* Most solemnly.

Q. As far as you know?—*A.* Yes.

Mr. Justice BLACKBURN: Was it cotton-seed or cotton-cake?

Mr. FIELD: The Report says cotton-seed. "I find in the cake cotton-seed."

The WITNESS: "Cotton-seed husks," I think were the words.

Mr. FIELD: Yes, those were the words. You do use cotton seeds in your mill?—*A.* I have only used it once.

Q. You do use them?—*A.* I have only used it once.

Q. Were you using cotton-seeds at the time this was made?—*A.* No; July, 1871, was the last time I used it.

Q. What quantity of cotton-seed were you using in July, 1871?—*A.* I crushed 160 tons of cotton-seed.

Q. Under these rolls, with this machinery?—*A.* Yes; not with the identical rolls.

Mr. Justice BLACKBURN: You crushed a certain number of tons?—*A.* 160, as far as my memory serves me.

Mr. FIELD: Of cotton-seed?—*A.* Yes.

Q. Was that screened?—*A.* It is hand-screened—it is picked over by hand, hand-picked.

Q. Was it screened?—*A.* Hand-picked.

Q. Were the husks separated from it?—*A.* Oh, no, it is never done in Hull.

Q. Well, I do not know, I am asking for information. The Report says you had cocoa-nut cake. I will ask you about cocoa-nut cake. When did you have cocoa-nut cake?—*A.* Well, I have had some at table; my wife has had some for dessert, but I never saw it as an article of commerce. I never knew there was such a thing.

Q. Then if it was in the cake, you cannot tell where it came from?—*A.* It was not in the cake.

Q. I know you say that, but I am putting this to you—if it as in the cake, can you tell me where it came from?—A. No, cannot.

Q. Rice dust?—A. No.

Q. Millet-seeds?—A. As many millet-seeds as there are in ere (pointing to a sample).

Q. That is so?—A. Oh, yes, one in a thousand.

Q. Is that one of the seeds that you say grows with the nseed?—A. Yes; it is imported largely into England. It is a right yellow seed, very scarce—I may say one in 10,000.

Q. Broken wheat, how do you account for that?—A. In the ran. The bran is put into wheat bags, which may not have een properly shook out, and so the bran comes with some wheat n it.

Q. What is bran—what is it made of?—A. Well, I am as gnorant as you are.

Q. Husks of barley?—A. Well, a stray barley-corn might ave got into it, from the seed coming in a steamer that had ome barley on board, but only by accident; and if it came so he seed would be ground.

Q. I cannot understand how, if it came in bags ——?—A. Black Sea linseed does not come in bags, but in bulk. Calcutta does.

Q. Which of the two cakes were made of Black Sea and hich of Calcutta?—A. They were all made of three-quarters Calcutta and one-fourth Black Sea.

Q. Mouldy wheat is another thing found by Dr. Voelcker?—A. I never saw it.

Q. You do not think there could be any in it?—A. Well, I never did see any, and so I do not know what it looks like.

Q. With regard to the sesamé-cake, what age was that when it came to you?—A. Fresh made.

Q. When was it made?—A. In October.

Q. Have you got the invoice of the sesamé here?—A. My solicitor has got it.

Mr. Justice BLACKBURN: I think it has been put in.

Mr. FIELD: I have not seen the invoice of the sesamé-cake.

Mr. SEYMOUR: It was put in—Young and Timms.

Mr. FIELD: Have you got any of the sesamé-cake now?—I have, as it is after it has been passed through Thompson and Stather's machine.

Mr. Justice BLACKBURN: Have you none of the unbroken sesamé-cake?—A. No, I do not bring it for this reason—I do not put it under the stones in the form of cake, but I make it into meal; I thought I should have it suggested that there was something added that was different to the cake.

Mr. FIELD: Have you got, then, some of the sesamé-cake at home?—*A.* Yes.

*Q.* And that you have not brought?—*A.* I have not brought that, because I do not put it under the stones; I put the meal under the stones. We can have plenty of it, if necessary.

*Q.* I will now ask you about the cake which you have produced to-day, the "Triangle Best." Look at these two specimens of cake (handing the same to the Witness). Are they specimens of the same cake?—*A.* This (pointing) has been wet.

*Q.* Look at the texture, and tell me whether the texture of the cake is the same as the one you produce now?—*A.* This (pointing) is being made now.

*Q.* When was the cake you now produce made?—*A.* Within the last week.

*Q.* Oh!—*A.* The cake sent to Mr. Wells is three-quarters Calcutta and one-quarter Black Sea. This (pointing) is three-quarters St. Petersburg and one-quarter Calcutta.

*Q.* Then that is no representation of the cake you sent to Mr. Wells?—*A.* No; this is only what we are sending out now.

*Q.* I only want to get the facts.

Mr. SEYMOUR: To show the brand?—*A.* Yes, it was produced to show the brand. Mr. Field asked for it.

Mr. FIELD: I understand you grind up the sesamé-cake as you buy it?—*A.* I stow it away, and use it as I want it.

*Q.* Is that at all screened in any way?—*A.* I told you it went up by elevators. It is screened to get all the sticks and anything of that sort out of it.

*Q.* What becomes of these screenings?—They are thrown away.

*Re-examined by Mr. SEYMOUR.*

*Q.* I have very little to ask you, but, if I understand you rightly, the dodder and other foreign weeds or substances that have been taken from pure linseed, you mix with pure linseed, in making the commonest and lowest type of cake, where you are obliged to use linseed for that purpose?—*A.* Yes, dodder-seed being a good feeding article.

*Q.* Quite so. Do you, in making your "Triangle Best," take precautions and care to prevent any of these screenings being mixed with it?—*A.* Emphatically—all the care possible.

*Q.* Just tell me what you do when you speak of taking all the care possible—is the floor swept and prepared?—*A.* It does not go on to the floor; the screenings are delivered into bags, and the bags are tied.

*Q.* Then unless they are untied they will not get mixed from

my accident?—*A.* No, because the linseed that is taken to make the cakes below, is taken from the pile when we want it by the machinery; it is drawn into the hoppers, and comes down without anybody touching it after it has left the pile. It appears in the lower floor after it has gone up and through the screen and down to the bottom, and if anything was put to it, it would have to be put at the stones.

*Q.* Wilfully?—*A.* Wilfully; in the presence of twenty or thirty men.

*Q.* You have mentioned two men that you say are not here, although Mr. Smales is here, and Stevenson the foreman?—*A.* Yes.

*Q.* With reference to the other two men, did they do anything more than obey mechanically the orders that were given them?—*A.* No.

*Q.* I want you to explain. I do not want to have any point made hereafter which is not cleared up now. You said you got some seed by the vessel 'D. M. Parke'?—*A.* The invoices were put in.

*Q.* I wanted to know that; that is the 395 quarters that my Lord asked you, I think, a question about?

*Mr. Justice BLACKBURN:* Yes, I understand it now; at first I misunderstood it. I first understood him to say that that was Calcutta seed that had arrived, which would not have been consistent with what he was saying, but afterwards he said it was Black Sea.

*Mr. SEYMOUR:* When did that arrive at your mills?—*A.* On the 30th January.

*Q.* Was that used in any portion?—*A.* I put in the invoice for fear I should be unable to swear that it was entirely 'Varina.' I think it went to make pure.

*Q.* Your impression is, it was not in; but you produce the invoice for fear?—*A.* For fear I should be charged with leaving it out.

*Q.* But now supposing it in, what sort of quality is it?—*A.* It is better than the 'Varina's.'

*Q.* A higher price?—*A.* I think so; but not only that, but the allowance was 4.04, and the standard being 4, it was the cleanest I had ever known.

*Q.* It was within .04 of the very purest?—*A.* Yes.

*Q.* I will ask you one question which does not strictly arise; it is only to identify a parcel upon which I cross-examined Professor Voelcker yesterday. I asked him whether he had analysed a sample sent to him by Mr. Knowles.

*Mr. Justice BLACKBURN:* I think he produced the analysis.

*Mr. SEYMOUR:* The linseed and cake. It is merely for the

sake of identifying some evidence hereafter. I want to ask this witness what linseed and sesamé, and in what proportions, are in the sample he gave to Mr. Knowles to send to Professor Voelcker?—*A.* I saw the sesamé-cake taken from the pile, *ex Result.*

Mr. Justice BLACKBURN: Just let us see for a moment what it was. There were a great many things asked of Professor Voelcker.

Mr. SEYMOUR: I asked Dr. Voelcker whether he had not made an analysis on July 24th for Mr. Knowles.

Mr. Justice BLACKBURN: My note is "Last month, July 24th, I received a sample from Mr. Knowles."

Mr. SEYMOUR: That is it. I only want to identify the seed and sesamé in that sample, that is all. (To the Witness.) What sesamé was it you sent and gave Mr. Knowles?—*A.* Some of the sesamé that was in the cake Mr. Wells got. I saw it taken from the pile where it had been placed when it came from the 'Result.' I saw it taken to the machine and passed through, and I went with it into the mill.

Q. Then you can warrant it was the same?—*A.* Yes.

Q. Now as to the linseed?—*A.* This is the linseed (producing a sample). The same linseed as that which the "Triangle Best" was made of.

Mr. FIELD: Which?—*A.* That "Triangle Best" that you asked me about—three-fourths Petersburg and one-fourth Calcutta, and 20 per cent. sesamé was put in. This linseed contained the seeds which Dr. Voelcker said were, some of them, deleterious, and made out of rubbishing linseed.

Q. I understand you to say that the linseed you used in the cake which Mr. Wells got had three-fourths Calcutta to one of Black Sea; the linseed you sent up to be analysed was three-fourths Petersburg and one Calcutta?—*A.* Yes.

Q. And therefore it was not so pure linseed as the other?—*A.* It had rather more admixture.

Mr. FIELD: Do I understand you to say you gave these samples to Mr. Knowles for the purpose of being sent to Dr. Voelcker?—*A.* I did on the 24th of July.

Q. And did not communicate with Dr. Voelcker that it was for the purpose of this trial?—*A.* I did not send it myself.

Q. It was sent for the purpose of this trial?—*A.* I knew from Dr. Voelcker's prejudice against the Hull crushers that I dare not send it to him direct.

JOHN STEVENSON sworn: *examined by Mr. CAVE.*

Q. Are you foreman in Mr. Kidd's mill?—*A.* Yes.

Q. I think you have been in the business of a seed crusher for thirty-five years?—A. Yes.

Q. You have been with Mr. Kidd seventeen years and as foreman fifteen years?—A. I have.

Q. Have you the superintendence of the mill and of the crushing of the seed?—A. Yes.

Q. Were you engaged as foreman at the time the seed was crushed which made the cake that was sent to Mr. Wells?—A. I was.

Q. You heard what Mr. Kidd has said as to the seed out of which that was made?—A. Yes, I know what seed it was made from.

Q. Linseed, sesamé, and bran?—A. Yes.

Q. Are those the materials out of which that cake was made?—A. It was made from Calcutta and Black Sea linseed.

Q. Sesamé-cake?—A. Yes.

Q. And bran?—A. And bran.

Q. Was the linseed out of which it was made a good sample of linseed?—A. Fine linseed; fine clean linseed.

Q. What do you say as to the proportion of foreign seeds in that?—A. Well I am sure I do not know.

Q. Was it less or greater than usual?—A. Well the Calcutta was finer than usual, and the Black Sea was about as usual.

Q. How was the sesamé-cake?—A. It was a splendid sample.

Q. And the bran?—A. A very good sample indeed, the same as we get usually; fine wheat bran.

Q. Do you make entries of the dates when those materials come into the mill?—A. Yes.

Q. And you have got a book containing those entries, have you?—A. Yes.

Q. Are you able to say that this cake supplied to Mr. Wells was made out of those materials you have spoken of?—A. Yes.

Q. It was made under your superintendence by certain pressmen?—A. Yes.

Q. Was it possible for any poisonous ingredients to get into the cake in the course of the manufacture?—A. No.

Q. You have heard Mr. Kidd describe the way in which it is made?—A. Yes.

Q. Is that correct?—A. It is.

Q. And did you personally superintend the making of it?—A. I did; of course I was there in the daytime you know.

Q. Was there any cotton-seed or cotton-cake in the mill at that time?—A. No.

Q. Or cocoa-nut?—A. No.

Q. Or rice?—A. No.

Q. Or sweepings of corn warehouses?—A. No, I never saw any in the place.

Q. Now, we hear that five tons of this cake was delivered on the 6th of February?—A. I do not know.

Q. Don't you keep a book of the deliveries?—A. Yes, but I have not the book here.

Mr. Justice BLACKBURN: I think we have got the evidence of it, and I do not understand it is in dispute.

Mr. CAVE: Was anything put into that cake except that Calcutta and Black Sea linseed, sesamé-cake and bran?—A. No, nothing—not to my knowledge.

Q. In the course of making the cakes are the materials fully mixed together?—A. Yes, under the stones.

Q. And after the cakes are pressed are they stowed away together?—A. They are put into a rack after they come out of the press.

Q. And after that they are stowed away in the cakehouse?—A. They are taken away in barrows, and stowed away in the cakehouse.

Q. Is any cake made except for the purpose of crushing the seed, or with the intention of crushing the seed and getting the oil out of it?—A. No.

Q. Is any cake made with the seed purposely left whole in it?—A. No, of course not; we want the oil out of it.

Q. Do you remember some cake being returned from Mr. Wells?—A. Yes.

Q. Was it in bags?—A. Yes, it was.

Q. Had it got a seal on?—A. It had a proper seal on.

Q. Whose seal was it?

Mr. Justice BLACKBURN: I do not remember this evidence about its being returned.

Mr. CAVE: We shall prove that it was returned afterwards.

Mr. Justice BLACKBURN: Mr. Field will know if it is a fact or not.

Mr. FIELD: Part of the eight tons, I believe.

Mr. Justice BLACKBURN: I do not understand it; I do not think the thing was mentioned before; at all events I did not catch it.

Mr. CAVE: Do you remember some cake coming back to the warehouse in bags, with a seal upon it?—A. I do.

Q. Was that Messrs. Ayre's seal?—A. I saw it.

Q. How much was there of it?—A. There was somewhere about eight tons.

Q. Did you go with Spetch, Mr. Ayre's foreman?—A. Yes, I did.

Q. And did you take portions of this cake?—A. Yes.

Q. And supply it to certain cowkeepers—George Roundtree, George Smith, Mason, and Hornby?—Yes.

Q. Now just look at these four orders (handing the same to the witness)?—A. They are all my handwriting.

Q. You are able from this to say that those deliveries of cake were made?—Yes.

Q. Just give me the dates, the quantities, and the persons from the orders?  
A. Five tons of Triangle Best delivered to Ayre Brothers, ordered February 6th; number of order, 1381. January 29th, 1872, an order to deliver to the North-Eastern Railway Company five tons of Triangle Best linseed-cake, sent by Ayre Brothers. January 29th, 1872, five tons; delivered February 6th. Ordered 1st February, 1872, five tons; delivered February 14th. February 9th, 1872, five tons; delivered February 14th. February 14th, 1872, five tons; delivered February 16th.

Q. Now were those twenty tons made out of the same material as the cake that was sent to Mr. Wells?—A. They would be.

Q. Are those also your endorsements?—Yes, that is my handwriting.

Q. "January 27th, two tons; delivered February 3rd. January 24th, two tons; delivered February 2nd"?—A. Yes.

Q. Were those four tons also made out of the same material as the cake supplied to Mr. Wells?—A. Yes.

*Cross-examined by Mr. FIELD.*

Q. What was the number of the order delivered on the 14th of February?  
—(No answer.)

Q. When did you first bring in the bulk out of which these cakes were made—when did you first begin to work upon it?—A. Somewhere about the middle of January we should start to make the best cake.

Q. Was there any other seed besides the two cargoes we have heard of mixed up with the bulk?—A. No.



Q. When was the last time you made ordinary cake—were you making any at that time?—A. I cannot tell you. We had made some a week or two before.

Q. Do you make the ordinary cake at the same time that you make best cake?—A. Sometimes we make one sort in one mill and the other in the other mill.

Q. How many mills have you?—A. Well, we have like two.

Q. Two mills?—A. Well, there is one here and an engine here, and the other is on the other side of the wall (explaining).

Q. All in the same room?—A. No.

Q. There is the engine-house between?—A. There is the engine-house between, and there is a wall runs right away along from end to end. They cannot get mixed. One mill's stuff cannot get mixed with the other's.

Q. Were you making ordinary and common at the same time that you were making best?—A. I cannot say—not at that time.

Q. Who has the management of the ordinary mill?—A. Sometimes we make it in one place and sometimes in the other.

Mr. Justice BLACKBURN: You have got all the books here, and you can in a moment ascertain whether or not that is so. Just turn to the books and see whether you made any of the ordinary cake in January or not. There must be a book that will tell that?

After some confusion, caused by the Witness referring to the year 1871 instead of 1872:—

Mr. FIELD: What quantity of "Buffum" were you making on the 12th February?—A. I do not know a phrase like that.

Q. You never heard of it?—A. Well, I have heard of it, it is vulgar speaking when they call it "Buffum."

[A long examination here ensued as to the dates of manufacture of the different descriptions of cakes, and on Mr. Kidd being recalled and referring to his books, it appeared that on the 5th of February all three descriptions were made, that no more Plain Triangle was made until the 12th of February, that Triangle Best was made on the 6th, 7th, and 8th February, then not until the morning of the 13th February.]

Q. Are the two first men here; are they working in order; or how do you take their time? Middleton and Stevenson are, I think, working all day long?—A. Yes.

Q. And that book shows what they make?—A. Yes.

Q. When you made ordinary cake on the 12th, was that made from the same linseed as the best was made of?—A. Some of the same linseed.

Q. Very pure?—A. Fine seed.

Q. What did you mix with the ordinary on the 12th to make it?—A. Linseed, bran, and nut-cake.

Q. That was very fine linseed?—A. Yes.

Q. Was any screenings or siftings put into that?—A. No, I do not remember that there was.

Q. I want to know; Mr. Kidd told us?—A. We put a portion in if we have any, but if we have not any we cannot put it in.

Q. That I am well aware of. But Mr. Kidd told us if the linseed was very good, the siftings were put in to bring it down to what is called a good cake?—A. It is, if we have any in stock.

Q. You had been making a good deal of pure just before?—A. I won't swear whether we had or not.

Q. You had been making all the week before. You had been making hardly anything but pure. Just look at your book and say whether that is not so? Had you not been making for the whole week before pretty nearly nothing but pure (handing the book to the witness)?—A. Well, then, of course there would be some put in.

*Q.* You have no doubt about it, have you; you must have got a good stock of screenings out of that week's manufacture of pure?—*A.* Well, we should have a good bit.

*Q.* And that went into the ordinary that you made on the 12th?—*A.* It would not all go in.

*Q.* I know that; I am thinking, you know, some went somewhere else; did any of it go into the best by mistake?—*A.* It cannot get in there, it is all bagged up.

*Q.* But the best was made on the morning of the 13th. Could not some of that have got into the best that was made on the morning of the 13th?—*A.* No.

*Q.* Why not?—*A.* Because we always keep it bagged up.

*Q.* What?—*A.* The screenings.

*Q.* And who does the mixture, the putting of the screenings into the ordinary?—*A.* The men that work upstairs.

*Q.* Oh, you don't do it?—*A.* No.

*Q.* What is the name of the man who does it?—*A.* There are two or three.

*Q.* All of them do it?—*A.* They are all working upstairs; the man they call Logdon has the charge of it.

*Q.* Is he here?—*A.* No.

*Q.* I thought not; Logdon, who has the charge of putting the screenings into the pure, is not here?—*A.* We do not put any screenings into the pure.

*Q.* No, not into the pure, I mean into the ordinary.

*Mr. Justice BLACKBURN:* Let me understand if I know rightly what you mean. You say the screenings are in bags upstairs, and when you are putting them into the ordinary somebody carries the bag down and puts them under the stones?—*A.* No, it is put in in small proportions, and goes up among the seed.

*Q.* Do you mean that it is put into the seed before the seed goes between the rollers?—*A.* Yes.

*Mr. FIELD:* In what room is it that the screenings are put into the linseed?—*A.* It is brought down and put into the elevators, and that takes the seed up.

*Q.* If I understand rightly, the linseed is stored on the top floor?—It is.

*Q.* And the screenings are on the top floor?—*A.* Yes.

*Q.* Now tell me when do the screenings get into the linseed?—*A.* We bring it down stairs.

*Q.* When?—When we want to make a mixed cake.

*Q.* Then Logdon is the man who has charge of the doctoring?

*Mr. SEYMOUR:* Don't say that.

*Mr. FIELD:* Well, he has to put the screenings into the linseed?—*A.* Logdon is there; he is one of the men; he is what we call the up-stairs man.

*Q.* Does he send the screenings down by the elevator?—*A.* No, we carry them down.

*Mr. Justice BLACKBURN:* Just let me try if I can understand it a little better. I have understood that when you are going to put it through the rollers, you put it into the hoppers from whence it goes to the rollers?—*A.* Yes, but it has to go into the elevators first.

*Q.* Then the elevators you speak of take the linseed and lift it up and put it into the hoppers, and from there it goes to the rollers?—*A.* Yes.

*Q.* When you want to put any siftings in order to lower the quality of the seed, you take them down and put them into the elevators along with the seed, so that the linseed and siftings go together into the hoppers?—*A.* Yes.

*Mr. FIELD:* Now I understand it; the elevators are for the purpose of carrying it up into the hoppers?—*A.* Yes.

Q. When it is carried down to the elevators so that it may go into the hoppers, who carries it down?—A. One of the labourers.

Q. Any one, or one in particular?—Any one, not one in particular.

Q. And who gives it to the labourers?—A. When I want to make this Triangle Cake I tell him to bring a certain portion down, and we put it in when we want it.

Q. That is to say when you are there, but you are not there night and day?—A. No.

Q. Who does it at night?—A. We run as much seed into the bin in the day as will serve the night.

Q. But you told me just now that Logdon was the person in charge?—A. In the day-time, we have not any one there at night.

Q. What does he do?—A. He lands the seed.

Q. And puts it into the elevators?—A. Yes.

Q. What do you mean by landing the seed?—A. Taking it out of the lighters.

Q. And putting it into the elevators?

Mr. Justice BLACKBURN: That is a very different thing.

Mr. SEYMOUR: He says taking it out of the lighters.

Mr. Justice BLACKBURN: We are talking just now of what is done with the seed when it is taken out of the warehouse to go into the elevators to go into the hoppers; he was answering you something about taking it out of the lighters to go into the warehouse.

Mr. FIELD: I was speaking of the other process. (To the Witness) Where do you get the linseed from when you are going to make ordinary cake?—A. It runs down the spout into the elevators, and the elevators take it back and put it into the hoppers.

Q. It runs down of itself?—A. Yes, with a slide.

Q. Then it is carried up by the elevators straight?—Yes.

Q. Without anybody's hand?—A. Without anybody interfering with it.

Q. Then what is to be done is to put the siftings into that?—A. Just so.

Q. Who does that?—A. First one and then the other; we have no man in particular.

Q. Anybody who comes first?—A. Yes.

Q. Did you make this cake, this "Triangle Best," on the morning of the 13th?—A. What cake is that?

Q. The "Triangle Best" that is made on the morning of the 13th?—A. I do not make any at all.

Q. Did you put any siftings that day into the ordinary—on the 12th?—A. I cannot say whether there would be any put in or not. I should think there would.

Q. Was the cake that was made on the morning of the 13th made in the same place—the same part of the mill as the ordinary that was made on the 12th; look at the names of the men?—A. No, they are not made by the same parties.

Q. Was it made in the same building?—A. No, one was made in one mill and the other in the other.

Q. How far are they from each other?—A. Well, I am sure I never measured it. I cannot tell you; there is a wall and engine parts them.

Q. Do the same men work sometimes in one mill and sometimes in another?—A. No.

Q. They all keep in one mill?—They all keep in one mill—they keep in their own place.

*Re-examined by Mr. SEYMOUR.*

Q. When you make the "Triangle Best" cake, is it possible that the screenings can mix with it in the process of manufacture?—A. No.

Q. Can screenings get into any cake unless intentionally used?—A. No, not unless we put it in.

Q. Did you put any particle of screenings in the cake that was sent to Mr. Wells?—A. No.

Q. When you want screenings to equalize or lower the ordinary cake by putting screenings with the pure linseeds, does any one give orders for the mixture or proportion except yourself?—A. No.

Q. You have already said that you give orders for the quantity for night as well as day?—A. I give orders for the quantity to be put in.

Q. And with regard to the suggestion of Logdon “doctoring,” has he anything more to do than to obey your directions?—A. No.

Q. Do you deliver cake out on the day it is made—cake made on the 13th, would it be delivered out on the day it is made?—A. I should say it would. I cannot say.

Q. You cannot tell one way or the other?—A. No, I could not.

ROBERT SMALES sworn : *examined by Mr. SEYMOUR.*

Q. Are you a seed crusher in the employment of Mr. Kidd?—A. I am.

Q. And I believe you have been thirteen years in the employ?—A. I have.

Q. And is it your duty to take the direct superintendence of grinding the materials in the mills?—A. It is.

Q. Did you in that capacity superintend the grinding and crushing of the seeds which resulted in the cake that was sent to Mr. Wells?—A. Well, I should think I should.

Q. You know the distinction between “Triangle Plain” (ordinary cake) and “Triangle Best”?—A. Yes.

Q. Now, in making the Triangle Best, was any portion of screenings or siftings mixed with it?—A. I cannot say that. I am not working in the chambers, I only see the seed when it comes to the rolls.

Q. But was any put in with your knowledge below?—A. No.

Q. Could it be put in below without your knowledge?—A. No, nothing of the sort.

Q. Then did you see anything put in but the linseed, the sesamé, and the bran?—A. Nothing else.

*Cross-examined by Mr. FIELD.*

Q. Were not you making ordinary cake on the 12th?—A. I cannot tell you that : I keep no dates, I go according to orders from the foreman.

Q. Your name is put down in the book as to what you are making?—A. Yes.

Q. Do you recollect making any cake on the 13th?—A. No.

Q. You cannot tell one day from the other?—A. No, not the dates. I should either be working at that time on the day spell or the night spell.

Q. You have no memory at all as to what was put into any cake one way or the other?—A. Not at that time ; but I know we never vary or change in our best cake, nor our ordinary cake neither ; we do not vary in our mixing.

Q. But you know nothing of any particular cake going out to anybody?—A. Decidedly not.

Q. You cannot tell whether the cake that went to Mr. Wells was ordinary ; or pure, or best?—A. No.

Q. All you mean to say is that when you put the screenings you put it into the ordinary?

Mr. Justice BLACKBURN : I do not think he had anything to do with the

screenings?—*A.* I have nothing to do with the screenings. I am not in the chambers at all. I am in the mill to see that the proportion of the stuff was equally divided when it came up from the roll.

*Q.* If I understand rightly the screenings are put in the elevators, and put into the hoppers, and you do not see the stuff till it comes out ground, so that you do not know even about the screenings being put into the ordinary?—*A.* That is right.

*Mr. FIELD:* Then you are the grinder?—*A.* No, I am the pressman.

*Q.* That is the last stage?—*A.* Yes.

*Q.* First of all the elevator takes it into the hopper, then it is ground, and then it is pressed; how far is the presser from the grinding-stones?—*A.* I work about a yard and a half off.

*Q.* In the same building?—*A.* Yes.

*Q.* Where do you first get it in bags—when you first touch it?—*A.* Yes, I do, when I first touch it.

*Q.* You have to take the bags under the grinding-stones?—*A.* Yes.

*Q.* Or to put it into the bags from under the grinding-stones?—*A.* No; it comes from underneath the stones—the grinder takes it from underneath the stones, and then the parer puts it into the kettle, draws it out of the kettle into the bags, and I put it into the press.

*Mr. Justice BLACKBURN:* That is your mechanical work; but, if I understand you rightly, though you work as pressman, you have the overlook of the grinding?—*A.* I am superintendent of the mill, and receive orders from the foreman.

*Q.* Have you anything to do with the sesamé-cake?—*A.* I have to put it under the stones.

*Q.* You do not see the sesamé-cake until it is under the stones?—*A.* I have to see it put under.

*Q.* Where does that come from?—*A.* From the stones; it is brought in in bags and emptied out.

*Q.* Broken up?—*A.* Yes.

*Q.* Who breaks it up?—*A.* Two men at the machine—one they call Coggin, and the other they call Oates.

*Q.* Where do they break it up?—*A.* Just behind the wall.

*Q.* In a different room from yours?—*A.* Yes; we are parted by a nine-inch wall.

*Q.* In another room where the machine is?—*A.* Yes.

*Q.* It is broken up by the machine?—*A.* Yes; put into bags and brought into that room.

*Q.* What do you call that?—*A.* Into the mill and emptied out.

*Q.* What do you call peppering—what does it mean?—*A.* I never heard it mentioned.

*Q.* Or “Buffum”?—*A.* I think I heard a slang word of that sort; it is frequently used by the men in the mill—it means this here Niger-cake and bran.

*Mr. Justice BLACKBURN:* “This here” what?—*A.* This here sesamé-cake and bran.

*Mr. FIELD:* You never heard of “peppering,” and you do not know what that means?—*A.* Never.

*Q.* Do not you know this, that when you are making ordinary cake the linseed is not pressed so much as it is when the best is being made?—*A.* No; the press is nipped up equally the same, because if we were to have any whole seed the foreman would directly come and call me everything. We could not get the oil out of it.

*Q.* But I suppose a man who bought a cake and broke it and saw the linseed in it would think he had got a very good thing?—*A.* I think he would, but it would be very much against the master.

Q. Now, with that very object, is not it that in making the "Buffum" you leave purposely a certain number of seeds that they may appear in the cake and show as if it was a good linseed-cake?—A. No, never.

Q. In grinding do you grind the "Buffum" as much as you do the linseed?—A. Why, perhaps a minute or two longer sometimes; one mill will be on perhaps twelve minutes.

Q. Which is the longer?—A. The "Buffum" would be on about twelve minutes.

Q. Longer?—A. No, altogether.

Q. How long will "pure" be on?—A. Pure will be on fourteen.

Q. Eighteen to twenty?—A. The pure?

Q. Yes?—A. We grind the pure eighteen minutes perhaps.

Q. And the other?—A. Twelve, or from twelve to fifteen; some mills are longer than others.

Q. And the other from eighteen to twenty?—A. No, not over twenty; about eighteen minutes is as much as we could do, because we could not get stuff fast enough to keep our presses going.

*Re-examined by Mr. SEYMOUR.*

Q. The sesamé, being already ground, does not require so much grinding?—A. No.

Q. And that explains the difference?—A. Yes.

Q. Have you ever, under any circumstances, put or left whole linseed in any cake that you have made—purposely; or left it whole that it might look well to the farmers?—A. Never in my life, and I have been in the business thirty-four years.

Q. Do you know when "Triangle Best" cake is being made?—A. Yes; sometimes we change twice in twelve hours.

Q. And are you there so as to see when the sesamé is put in and the bran is put in?—A. Yes.

Q. You see them all put in before they come out and are crushed together?—A. Yes.

Q. And is it possible for anything to be put in except those without your knowledge?—A. No.

Q. And are you able to state positively that nothing has been put in?—A. I can say that nothing has been put in.

Q. My Lord, will you allow me to ask this, Have you seen cocoa-nut or rice, or anything of that kind, about the mill?—A. Never.

Q. Or corn-warehouse sweepings?—A. Never.

Mr. ALGERNON SYDNEY AYRE re-called: *examined by Mr. CAVE.*

Q. How long have you been in business as a merchant?—A. My present firm seven years.

Q. Before then, have you been acquainted with the trade?—A. I have.

Q. How many kinds of cake are known in the trade?—A. Three, generally speaking, the Common, the Genuine, and the Pure: the relative prices being usually, for instance, 8*l.*, 9*l.*, and 10*l.*; or 10*l.*, 11*l.*, and 12*l.*; usually, there being a difference of 1*l.* between the ordinary and the genuine, and also a difference of 1*l.* between the genuine and the pure.

Q. What is understood in the trade as a pure cake?—A. Pure cake is supposed to be made from fine linseed, carefully screened.

Mr. FIELD: We cannot have that.

Mr. Justice BLACKBURN: No. What is told and known to or published in the newspapers to the farmers who buy it, would be something to the purpose.

Mr. FIELD: And also told to Mr. Wells it should be.

Mr. SEYMOUR: To the purchasers?

The WITNESS: Pure cake is known as cake made from fine linseed, carefully screened, and all the pure cakes are branded "pure." Genuine cakes are usually known as cakes made from linseed "as imported," from which the extraneous seeds have not been screened. Ordinary cakes are "as per sample"—anything. They are known to be mixed, and made of various articles.

Mr. CAVE: The linseed "as imported" varies, we are told, very much in quality?—A. It does.

Q. And, in consequence of that, does the genuine cake also vary in quality?—A. It does.

Q. In consequence of that, did you suggest to Mr. Kidd that he should make a cake of a uniform quality?—A. We did. I may say that the linseed from which genuine cakes are made, frequently contains a large quantity of rape-seed, which is very bitter, and the cattle very much object to it; and having had very many complaints—

Mr. FIELD: Are we to go into this? I do not see how it at all arises.

Mr. Justice BLACKBURN: Mr. Seymour seems to think it material.

Mr. SEYMOUR: In this aspect of the case, I think it material—it is suggested that we have made this cake for the purpose of deception.

Mr. Justice BLACKBURN: It strikes me, at present, that it is not only suggested, but proved.

Mr. SEYMOUR: That is what I am going to explain.

Mr. Justice BLACKBURN: Very well: I am willing you should try.

The WITNESS: Our arrangement with Mr. Kidd was, that the cake should be of the same value—that the rape-seed and so on should be taken out of it, that is, in other words, that a finer seed should be used, and sesamé-cake, which is known to be a good feeding cake, and also bran, which is known to be a good feeding article, should be used in the manufacture of it. This cake has always, from the beginning, been sold by us not as a genuine cake—

Mr. Justice BLACKBURN: Would you explain what you mean by being sold not as a genuine cake?

The WITNESS: I will, my Lord, if you will kindly hand me that circular (produced). Your Lordship will observe the circular—you will find that the "Triangle Best" appears at the top of the first column, and is not placed under "genuine quality," neither is it placed under "pure quality;" because, not being a genuine cake we did not wish to sell it as a genuine cake, and not being a pure cake we did not wish to represent it as a pure cake. I myself have gone round the country, and I can say positively that I have invariably told all our customers (who are dealers in the country) that the cake was not genuine, nor sold as genuine, nor pure, nor sold as pure. The price will be seen to be 10*l.* a ton—in other words, 25*s.* a ton below the price quoted for pure cakes: and we have never, to my knowledge, in any single instance, sold these cakes at above the difference in price that I mentioned. With reference to the two cakes in question, those cakes were not sold as pure cakes.

Mr. FIELD: I object to this. We have a correspondence upon this—

Mr. Justice BLACKBURN: The letters and correspondence will show how that stands when we come to try Mr. Wells' action; at present, we are not dealing with that, but with a general question.

Mr. CAVE: The libel charges that this was sold as best linseed-cake; therefore, I submit this becomes material to us.

Mr. Justice BLACKBURN: If that is so, you must produce the documents that passed between them.

Mr. CAVE: I propose to do so.

Mr. Justice BLACKBURN: If I remember rightly, when Mr. Field wanted them in you objected to them. However, I suppose we shall have them in now.

Mr. CAVE : Before we come to that, how long have you sold this "Triangle Best" linseed-cake?—A. I think about four years. I could tell by reference to our books.

Q. And about how many tons have you sold?—A. As nearly as I can tell between 9000 and 10,000 tons.

Q. And have you ever had any complaints about it?—A. We have not.

Q. Did you know Mr. Wells before the occasion when those two tons were sold to him?—A. Yes.

Q. And have you been in the habit of selling him cake?—A. We have.

Mr. FIELD: Were the orders in writing? Because, if so, let us see them.

Mr. Justice BLACKBURN: If we are to have anything about the contract between him and Mr. Wells, let us have the contents from the document themselves. We cannot enter into this without.

The WITNESS: Mr. Wells has had the pure cakes—

Mr. FIELD: Have the goodness to wait till your Counsel asks you the question, or my Lord permits it. If the orders are in writing, let them be produced.

Mr. CAVE: Has Mr. Wells ever given you any verbal orders?—A. To the best of my belief he has.

Q. For what has he given you orders?

Mr. FIELD: Ask what took place—

A. Mr. Wells has frequently called at our office in Hull, to give orders for cakes. Mr. Wells has had "Diamond K Pure," which are Mr. Kidd's pure cakes. He has also had "Diamond Mixed," which are common cakes; and the cakes in question are the "Triangle Best" which are supposed to take the place of the "genuine" cakes previously made.

Mr. CAVE: You say he has had "Diamond Pure"——?—A. Mr. Wells has a running contract with us for these cakes.

Mr. Justice BLACKBURN: Then *do* produce your running contracts, and then we shall know what we are about.

The WITNESS: Here, my Lord, are the entries. (Producing a ledger.)

Mr. FIELD: That is in your books—that is not the contract.

Mr. Justice BLACKBURN: We want the contracts which you exchanged with Mr. Wells.

The WITNESS: We did not exchange contracts, my Lord.

Mr. CAVE: Have you ever sent to Mr. Wells any of the "Diamond K Pure" cake?—A. We have—here are several—

Mr. Justice BLACKBURN: You have—that is enough.

Mr. CAVE: With that cake do you give a written warranty?—A. We do.

Q. And the price, I think, you have told us?—A. 11*l.* 5*s.* per ton: these were charged at 10*l.* per ton.

Q. On the 19th January, did you send a circular to Mr. Wells?—A. Yes we did.

Q. Have you got a copy of that circular?

Mr. Justice BLACKBURN: Is it one of those we had put in? We had two different sets, one containing a series of six or seven, and the other, a shorter one in larger type, in which it said "△ Best Linseed Cake."

The WITNESS: Yes, my Lord.

Mr. Justice BLACKBURN: Is it another document besides those?—A. No my Lord.

Mr. Justice BLACKBURN: If it is not in already, let it be put in now.

[The ASSOCIATE read the circular, as set out at p. 488.] -

Mr. Justice BLACKBURN: That is the document that went with the sample?

Mr. CAVE: Yes, (to the Witness) with that circular did you send a sample cake?—A. We did.



Q. On the 26th January did you receive a letter from Mr. Wells?—A. I believe we did.

Q. Was that the letter? (handing a document to Witness.)—A. That is the letter. Here is one before this. (A letter was put in.)

Mr. Justice BLACKBURN: Is not that one of those letters already in? The whole were put in, I thought, though not all read.

Mr. FIELD: No, my Lord, I think not this.

[The letters were then put in and read, and among them the following.

“MEMORANDUM

“FROM AYRE, BROTHERS, | January 27th, 1872,  
24 High Street, Hull, | To J. WELLS Esq.

“DEAR SIR,—We are in receipt of your esteemed favor of 27th inst., and in accordance therewith have pleasure in booking you 15 tons  $\Delta$  Best Lin. Cakes @ 10l. per ton. We order forward for Mr. Dean, Market Weighton Station, 10 tons; remaining tons in 5-ton lots to your address, Booth Ferry, by Fearnley's boat.

“Yours truly,

AYRE BROTHERS,  
per A. REDFERN.”

Mr. CAVE: When did you invoice 5 tons—

Mr. Justice BLACKBURN: I think there is no dispute that the goods were sent and delivered.

Mr. FIELD: The invoice is important; it is “5 tons  $\Delta$  Best Linseed-Cakes”—both invoices.

Mr. CAVE: Was there some delay in the delivery of the ten tons of cakes?

A. There was—Mr. Fearnley had not a boat ready.

Q. And on the 12th February did Mr. Wells come to your place?—A. He

Mr. FIELD: You are passing over a letter of the 5th?

Mr. CAVE: Where did he come to?—A. To our office—24 High Street, Hull.

Q. Was your brother there?—A. He was.

Q. What took place on that occasion?—A. Mr. Wells complained very bitterly that the cakes had not been sent off, and we said that we would send them as quickly as we could—that Mr. Fearnley had not a boat.

Mr. Justice BLACKBURN: I do not see how this can bear in any way on the case.

Mr. CAVE: I think it will be found presently that part of the conversation is every material.

The WITNESS: Mr. Wells then said he had looked at the sample we had sent him, and had melted it up, and that it seemed a good fair cake. He thought there was bran in it. I said there was also sesamé.

Mr. FIELD: What is that about sesamé?

Mr. CAVE: Just repeat your answer again. My learned friend has misunderstood you.

The WITNESS: Mr. Wells said he had melted the sample of cake, and it seemed a good fair cake; but he thought there was bran in it. I said there was; also sesamé.

Q. What did he say to that?—A. I do not know that he made any further remark. We were chatting. I believe I showed him also a sample again of the same cake in the office.

Q. And then ultimately it was sent off—the two tons?—A. Yes.

Q. Now do you remember seeing Mr. Wells afterwards?—A. I do.

Q. What day was that?—A. I cannot for the moment recollect the date, but it was after he had complained of the cake.

Mr. Justice BLACKBURN: How can that bear on the libel we are trying?

Mr. SEYMOUR: It bears upon his knowledge.

Mr. Justice BLACKBURN: That does not make it evidence in the slightest degree. This is an action against the Royal Agricultural Society. Mr. Wells has been cross-examined at some length, and you cannot ask afterwards a third person what was said.

Mr. CAVE: I want to prove what it was that was understood by Mr. Ayrton.

Mr. Justice BLACKBURN: You had Mr. Wells in the box, and you might have asked him about it. I must reject the evidence; it is a point that cannot bear upon the question at all. If it was supposed to be material, you did not ask Mr. Wells when he was in the box, but he may be recalled and may be asked about it. However, you cannot make it evidence in the cause.

Mr. CAVE: Will you tell us to whom these cakes were sent? Look at this order (handing paper to Witness).

The WITNESS: May I get the order book?

Mr. Justice BLACKBURN: I suppose it will do, because we have had Stevenson, who has produced the things which he had sent.

Mr. FIELD: What are they?

Mr. CAVE: They are orders.

Mr. Justice BLACKBURN: Are they the orders to Stevenson which are said to have been made material afterwards?

The WITNESS: I will tell your Lordship directly. Order No. 2777 Messrs. Glover, of Warwick.

Mr. Justice BLACKBURN: It may be that there are things which make that material, therefore I will write it down, but at present it is no evidence itself. If you are going to call Mr. Glover to state that he received that that is another thing.

Mr. CAVE: We are purposing to call these gentlemen.

Mr. Justice BLACKBURN: Directly Mr. Glover is called, and says he did receive these things, I do not suppose that there will be any objection admitting that a certain quantity got into Mr. Glover's hands?

[A technical discussion here ensued between Mr. Seymour and the Judge as to the rejection of the Witness's evidence of his second conversation with Mr. Wells, but which his Lordship still declined to admit.]

Mr. CAVE: (To the Witness) You gave an account of one interview which you had with Mr. Wells before the cake was delivered. Had you any other interview with Mr. Wells?—A. I cannot speak positively; I do not recollect.

Q. Had you any conversation with him relative to this cake before it was delivered?—A. I think not—I think only one.

Q. I will ask this: Are those delivery notes in favour of Glover?—A. 2700—

Mr. Justice BLACKBURN: If you are going to call the people who used some of this cake, we need not go into them individually.

Mr. CAVE: I was going to ask the names.

Mr. FIELD: I will not give you the trouble, but you can recall the gentlemen, if necessary. Give the names, and they can come and prove that matter.

Mr. CAVE: (To the Witness) On the 27th of March, did you go over Booth Ferry?—A. Yes, I did.

Q. And on that occasion did you obtain a quantity of cake from Mr. Simpson?—A. No, I did not. I sealed up some cake there.

Q. What cake was that?—A. A part of the 8 tons.

Mr. Justice BLACKBURN: That was the 8 tons that had been rejected returned?

Mr. CAVE: Yes my Lord. (To the Witness) Did you seal up that in the presence of Mr. Simpson?—A. I did.

- Q. And is he Mr. Wells's bailiff?—A. His clerk, I believe.  
 Q. And did you send that to Hull?—A. Fearnley called for it, I believe.  
 Q. And was your foreman Spetch with you?—A. He was.

*Cross-examined by Mr. FIELD.*

Q. When was this that you sealed up part of the 8 tons in the presence of  
 P. Simpson?—A. In March, I think. I made a note in my pocket-book at  
 the time—the 27th of March.

Q. Where was it?—A. At Booth Ferry.

Q. How much of the 8 tons was it?—A. That was sealed up?

Q. Yes.—A. I think about 13 cwt.

Q. How many cakes?—A. I should think there would be about 150 cakes.  
 I should think so.

Mr. Justice BLACKBURN: There would be more than that in 13 cwts.?—  
 About 300 cakes.

Mr. FIELD: What became of those 300 cakes?—A. Fearnley had orders to  
 take for them.

Q. What became of them?—A. They were given to some cowkeepers.

Q. When were they given to some cowkeepers?—A. Immediately on their  
 arrival at Hull. I should have given them the same day, but Fearnley was  
 the time in bringing them.

Mr. Justice BLACKBURN: We have had the cowkeepers named by Steven-  
 son: Roundtree, Smith, Mason, and Hornby.

Mr. FIELD: Did you personally give any of these to the cowkeepers?—  
 I did not.

Q. How many cakes were given to the cowkeepers?—A. I cannot say of  
 my own knowledge.

Q. When did you receive the remainder of the 8 tons?—A. I believe it all  
 came together.

Q. It all came together?—A. I believe in the same boat.

Q. Where is the remainder of the 8 tons now?—A. It has been sent out to  
 different parties.

Q. Before this conversation, which you had, as you say, on the 12th, had not  
 Mr. Wells paid for the cake?—A. It is quite possible he may have paid for  
 it. I do not know.

Q. Look and see; there is the handwriting. Do not you know he paid for  
 it (handing paper to Witness)?—A. Yes.

Q. That is your receipt for it?—Yes, from our office.

[The ASSOCIATE read the receipt dated "9th February, 1872."]

Mr. FIELD: You say you invariably told all your customers or dealers  
 something about this cake?—A. Yes, I did.

Q. Give me the names of a few of them?—A. I daresay I can give you  
 a few.

Q. Only a few of them?

Mr. Justice BLACKBURN: Some specific person?—I find Mr. Glover's name  
 and Mr. Hope's.

Q. Where does he carry on business?—A. At Warwick.

Q. Is he here?—A. He is here.

Q. When did you tell him?—A. I cannot say the date.

Q. What did you tell him?—A. I cannot say, except the fact that we had  
 introduced this Triangle Best cake in the place of the genuine cake.

Q. Give me the words?—A. I cannot.

Q. Give me the effect of them then?—A. That we had introduced the  
 Triangle Best cake in the place of genuine cake because the genuine cake did  
 not give satisfaction.

Q. That is what you told Mr. Glover?—A. It was to that effect. I cannot remember the exact words. It is a long time ago.

Q. Now will you give me the name of some other dealer that you told to?—A. I believe Mr. Hope.

Q. Where does he carry on his business?—A. At Hexham, in Northumberland.

Q. What did you tell him?—A. To the same effect. I cannot give you the exact words.

Q. Give me the name of another dealer?—A. I could give you a number. I will mention Mr. Starling, for instance.

Q. Give me a few names?—A. Mr. Bliss of Witney.

Q. I suppose you told all the dealers?—A. I did all those who dealt that class of cake, in other words I never sold a ton of cake without letting the people know.

Mr. FIELD: I beg your pardon, because I shall say you sold 20 tons without letting people know.

Mr. D. SEYMOUR: 20?

Mr. FIELD: Well 15. (To the Witness) Now do you mean to say that Mr. Wells told you that he had melted the cake?—A. I do.

Q. Melted the cake?—A. Melted the cake. I believe that was the actual term he used.

Q. Did you not in the first instance say that he had told you that he had thought there was bran and sesamé in it. Did you not say so?—A. I do not know that he said so—that he thought there was sesamé.

Q. Did you not yourself say so just now?—No; Mr. Wells told me there was bran, and I said there was not only bran but sesamé in it.

Mr. Justice BLACKBURN: He said that he believed it to be good cake, and I thought there was bran in it, and the witness said there was also sesamé.

Mr. FIELD: I should like to refer to the shorthand writer's notes upon that.

Mr. Justice BLACKBURN: I cannot take upon myself to be infallible, but shall be greatly surprised if it turns out as you state.

Several JURORS: My Lord we understood the witness the same as you Lordship.

Mr. Justice BLACKBURN: Then, Mr. Field, there are thirteen to one against you.

Mr. FIELD: Do you mean to say you told him that?—A. I do.

*Re-examined by Mr. SEYMOUR.*

Q. You say the remainder of the 8 tons have been sent out to various people?—A. Yes.

Q. In the ordinary course of trade?—A. Yes.

Q. Have you any complaints from any of the people who got it?—A. I have not.

Q. And did you supply the circulars that we have heard here to-day to all the people who dealt with you?—A. We did; I believe we sent out about 1680 circulars a week.

Q. Could you, if necessary, increase to a large number the names of parties who dealt with you in this cake?—A. Unquestionably.

Q. Recall your mind to the subject; did you ever sell a ton of it to any human being who was not perfectly aware that it was mixed?—A. Never to my knowledge.

Mr. H. H. AYRE, sworn: *examined by Mr. CAVE.*

Q. Are you in partnership with your brother?—A. I am.

Q. And you have heard the evidence that he has given?—A. Yes, I have.

Q. Is it correct?—A. It is correct. I think he has not given the conversation so fully as it really happened with Mr. Wells in our office.

Q. I was going first to ask you one general question—Have you also when selling these Triangular Best cakes given notice to the parties you were dealing with that it was a mixed cake?—A. I have always given it out so. When we first introduced the cakes, my brother travelled round the country.

Mr. FIELD: Don't tell us what he did when he was travelling.

The WITNESS: Travelling with the firm's instructions.

Mr. SEYMOUR: Was it with instructions from you?

Mr. FIELD: I object to that.

Mr. Justice BLACKBURN: We can't have that.

Mr. FIELD: I object to the instructions.

Mr. Justice BLACKBURN: I don't think we can have the instructions either.

The WITNESS: I myself have always done so. I have always represented the cake made from sesamé and bran, and that they had been introduced instead of the "genuine," because at the time the genuine were made, the bran from which they were made was very full of small extraneous seeds, and that complaints constantly came in of their being bitter, and of the cattle refusing them. And we said to the crusher "If you will make us a cake, and instead of all these bitter seeds will put in bran, we can sell a good deal of that cake, because we will put that to our buyers; and they would rather have good bran than nasty seeds." Some time after, when the sesamé was introduced, it was found that sesamé was a good feeding cake, and we agreed at half the bran should be taken out and sesamé put in its place.

Mr. SEYMOUR: Did you inform the persons with whom you dealt of your reasons for introducing it?—A. Yes, we made a great boast of it. We felt that we had made a great march in the trade in introducing it.

Q. Talking of a great march, I will just ask you this—Within the last few years, how many tons have you been doing in the trade?—A. Our last year was about 39,000 tons, I believe. We have increased our trade by about 100 tons a year for the last six years.

Q. And in those six years about how many tons have you sold?—A. Well, don't know.

Q. Well, over two millions?—A. No, not tons. Our turn over in amount has been two millions.

Q. I think you have supplied in sales something like 169,481 tons in six years?—Yes; that is so, taken from the ledger.

Q. Has your business been gradually increasing at the rate of something like an average of 7000 tons a year since you have been in business?—Yes. I may state that we have the largest trade in Great Britain in the cake trade. We do nothing but in cakes, and, therefore, we could not trifle with our name.

Q. There is one more question I wish to ask you. Do you make a farthing more in selling these "Triangle" cakes than by selling any other cake?—A. Not a farthing more. We sell what we are asked for, and we make no more profit on the one than on the other.

Q. You say you were present at the conversation with Mr. Wells?—A. I was.

Q. Just state, as nearly as you can recollect, what passed?—A. Mr. Wells brought me into the office rather excited and annoyed at the delay which had taken place in the delivery of his cakes, and we apologised, and said we were exceedingly sorry. He asked how it was, and we said Fearnley had not sent the vessel. We afterwards said the cakes had not been made, which really is partly true also. Fearnley had not sent the vessel, but if he had sent the vessel on a certain day they would not have been made. At the same time I simply mention that as part of the conversation. I then said, "I

hope you will like these cakes, Mr. Wells; they are a very good, useful cake." He said, "Oh, they seem a good cake, I have tried some of them for mucilage (that is, by dissolving them), and they seem to show well for mucilage, and appear to contain bran," or "but appear to contain bran," I don't know which he said. Either I or my brother then said, "they also contain sesamé," and I said they were made by the same crusher as the K Pure—that Mr. Kidd had made them. I believe I have missed out something. I was rather surprised at his buying these cakes, because, although mistakenly, I was under the impression that he only used pure cakes, and that is why I said those were useful feeding cakes; and Mr. Wells said he was going to try them upon his own stock, and I said he would find them good useful cakes.

Q. Is that all that passed?—A. I think that is all relative to this.

Q. And you told him there was sesamé as well as bran in them?—A. Oh, yes. We had never made a secret of that.

Q. And when you told him that did he make any objection or remark to it?—A. No; he knew they were 25s. under the regular price. He knew all about it.

*Cross-examined by Mr. FIELD.*

Q. He knew all about it under the contract?—A. Yes.

Q. That is what you say?—A. I do. I say he must have known perfectly well that these cakes were not pure best linseed cakes—10l. a ton. I say Mr. Wells knew perfectly well—must have known, because he is very largely in the cake trade, that a difference of 25s. a ton could not exist in pure cake.

Q. Do you mean that 25s. a ton would represent bran and sesamé?—A. I mean to say that these cakes are cheaper than the pure.

Q. I am not asking you that—you are so very fond of these cakes?—A. I think that is an answer to your question.

Q. Do you mean to say he knew perfectly well there was sesamé in these cakes?—A. No; I say he knew perfectly well they were not pure cakes.

Q. Why did you not say upon your circular that they were not pure cakes?—A. In Hull there are as many of one sort of cakes sold as another, and people in the trade know perfectly well the different brands.

Q. I am not talking about people in the trade, I ask you this: Had Mr. Wells ever had any of this cake before?—A. Not of this brand.

Q. Then why did you not—as you are so anxious to tell everybody that your "Triangle" cakes contain sesamé and bran—in your letter of the 19th of January, when you enclosed that circular, mention that to Mr. Wells?—A. Because the brand is so well known that we did not find it at all necessary to do so.

Q. That is your only reason—you knew that Mr. Wells always had best seed before. Tell me why, as you were so anxious to make the observation about sesamé-cake, you did not mention it in your letter enclosing the circular?—

A. On the contrary —

Mr. Justice BLACKBURN: Why did you not mention it in the circular? that is what you are asked.

The WITNESS: Because I did not consider it necessary; Mr. Wells has bought common mixed cake before.

Mr. FIELD: You wrote a letter with the circular—I ask you why did you not mention it there?—A. Because we took it for granted he knew what cake he was buying.

Q. You told him that it was "Triangle Best" linseed?—A. He receives our circular every week.

Q. You told him you offered him "Triangle Best" linseed—now I ask you, is that best linseed with fifty per cent of bran and sesamé—is that linseed-cake?—A. That is Triangle Best linseed-cake.

Q. Is it a linseed-cake at all?—A. A currant-cake is not made all of currants.

Q. Is it a linseed-cake at all?—A. I should say yes.

Q. Half of it being bran and sesamé, you say it is a linseed-cake?—A. I say that the trade treats all these as linseed-cakes.

Q. I am not asking you that. I know that the trade treats them so, and that is why we are here.

Mr. Justice BLACKBURN: Are not you now asking the witness a question which we shall soon have to ask the Jury?

Mr. FIELD: I ask him this: When you were so anxious to let everybody know, why did not you on your circular put the character and position of the cake; would not that be the better way than telling it in conversation—so that the world should know it?—A. We have sold these cakes for four years.

Q. Why did not you put it on the circular?—A. We cannot put everything on the circular.

Q. It would not be very long to say "Fifty per cent. sesamé and bran"?—A. A baker would not put the number of currants he puts into a cake.

Q. Well, we may have some complaints to make against bakers—very often we do—but I ask, why did not you put this in your circular?—A. Because it is not necessary; it is well known throughout the trade.

*Re-examined by Mr. SEYMOUR.*

Q. Has Mr. Wells himself been in the trade?—A. Very largely.

Q. Dealing in the trade?—A. I cannot say whether he deals, but he is well known in the trade, and we have always treated him as a dealer; we have no farmers in our connection at all.

Q. Have you dealt with him as a dealer?—A. Yes, we have; we have sold him Diamond P., the lowest quality that we sell.

Q. Have you your ledger showing your dealings with him?

Mr. Justice BLACKBURN: There was an objection raised to that which is a sound one, that unless you show the contracts (and they are not here), you cannot refer to the ledger.

The WITNESS: We have supplied him with "Diamond P."

Mr. SEYMOUR: How long have you dealt with Mr. Wells?—(no answer.)

Q. Have you sold him various kinds of cake during that time?—A. We have.

Q. Have you sold him pure cake?—A. Yes.

Q. Mixed cake?—A. Yes.

Q. High-priced cake?—A. Yes.

Q. Low-priced cake?—A. Yes; the "Diamond P." cake took the same rank exactly as the "Triangle." There are some ten or twelve brands in Hull which are ordinary brands, and cost some 2*l.* to 2*l.* 10*s.* less than the pure.

Q. Looking at the price and description of this cake, is there anybody in the trade who would not understand it to be mixed cake?—A. Nobody; everybody understands it so without exception.

## THIRD DAY.

Mr. JOHN HOPE, sworn : *examined by* Mr. SEYMOUR.

Q. Are you a merchant at Hexham, Northumberland?—A. I am.

Q. And I believe you are in the centre there of farmers and farmers' clubs?  
—A. Yes, we are.

Q. And have you dealt very largely in linseed-cake?—A. I have.

Q. Of various kinds?—A. Of all the various kinds: linseed, cotton, rapeseed, and everything of that kind.

Q. Have you had large transactions with Messrs. Ayre?—A. I have.

Q. How long back did you first commence dealing with them?—A. I have not gone through my ledger to see, but I am quite certain about 5 years—about that.

Q. Did they introduce to your notice the cake that has been called "Triangle Best" linseed-cake?—A. They did.

Q. Did they acquaint you with the circumstances under which they introduced that to the trade?—A. In 1868, the drougthy year, I was in Hull, and called at their office on business; and they told me that they were going to introduce this "Triangle Best" linseed-cake, the reasons alleged being that linseed, as imported, was often full of dirt and weeds, and by sifting it well, and making good linseed, and adding some bran, they would be selling a good, wholesome, useful cake that would be likely to give more satisfaction than the so-called "genuine" linseed-cake. I did not understand it to be made of linseed entirely, but, as they said, a composite cake.

Mr. Justice BLACKBURN: As I understand, you say you understood it to be made of sifted linseed and bran?—A. Yes.

Mr. SEYMOUR: And you understood it to be a composite cake?

Mr. FIELD: Mr. Seymour, please ask him what occurred.

Mr. SEYMOUR: He used that expression.

Mr. FIELD: What occurred; not what he understood.

Mr. SEYMOUR: By "linseed-cake," what is known in the trade?—A. That depends upon the term you put before it, whether it is pure or secondary, or of a third quality.

Q. Would you, in the trade, draw a distinction between "pure" linseed-cake and "best" linseed-cake?—A. Do you mean "Triangle Best"?

Q. Yes?—A. Decidedly; there is a difference of from 20s. to 25s. a ton, according to the market value of linseed and other things.

Q. Is "Triangle Best" known in the trade as a composite cake?—A. It is.

Q. As distinguished from the "pure" linseed-cake?—A. Decidedly.

Q. You have supplied very largely in Northumberland this particular cake, the "Triangle Best"?—A. I have sold it for four years, and have had no fault found with it; none.

Q. I believe you had some deliveries of "Triangle Best" in February last?  
—A. I had.

Q. On the 2nd, I think?—A. Yes.

Q. What quantity had you?—A. I think it was 2 tons then, and 2 tons later on.

Q. Were they supplied to customers of yours?—A. Yes.

Q. And have you had the slightest complaint about that?—A. None.

Q. In fact, I understand you to say that, during the five years you have dealt in this "Triangle Best" cake, you have supplied it largely throughout Northumberland?—A. Four years.

Q. And never had a complaint?—A. No; but you will understand me: I have never had a fault found with it. I have always pushed pure linseed-



cakes and pure everything, but I have sold this for what it was, and I have never had a fault found.

Q. You have pushed pure cake, and you have sold them this "Triangle Best" for what it was?—A. Yes; I told the people distinctly what it was.

Q. Then am I to gather from that, that telling people what was pure and what this was—

Mr. FIELD: Please, Mr. Seymour, do not gather anything.

Mr. Justice BLACKBURN: I think it would be better if you would simply ask questions and let him state facts.

Mr. SEYMOUR: Did you tell the people what this was?—A. Yes.

Q. Did you find the sale of this cake increase?—A. I pushed the pure linseed-cake, but this always sold well, it sold freely; but we never pushed it, because we always gave preference to the pure.

*Cross-examined by Mr. FIELD.*

Q. What do you suppose your percentage of sales would be of the "Triangle Best" and of the pure?—A. Speaking off-hand, and as near as I can go, I should think I sold from 30 to 35 tons of pure to 2 of "Triangle Best." About that: I would not like to be exactly positive to a fraction.

Q. Whose "pure" cake do you sell?—A. Oh, the best there is.

Q. Whose?—A. Kidd's "K Pure" and "H Pure."

Q. Did you issue circulars to your customers?—A. Yes, occasionally.

Q. Have you got any of your circulars here?—A. I have not.

Q. I should like to have seen them. Did you mention in your circulars (I will take your word for what they are) that this was a cake other than "Triangle Best" linseed?—A. I do not exactly understand your question.

Q. Did you in your circulars give it any other description than that of "Triangle Best" linseed-cake?—A. I put it under that term.

Q. Will you answer my question, please; it is a very simple one. Did you in your circulars mention it under any other description than that of "Triangle Best" linseed-cake?—A. No, I did not.

Q. Or in your circular draw the attention of your customers to the fact that it was sifted linseed with bran and sesamé?—A. I did not push that article.

Mr. Justice BLACKBURN: Do attend to the question. Did you in your circular mention anything about its having anything in it but linseed?—A. I did not.

Mr. FIELD: What is the meaning of the word best?—A. A trade mark purely; the same as Colman's Bull's Head on the mustard, or any other mark.

Q. What is the meaning of the word best?—A. Comparatively—

Q. What is the meaning of the word best; it is an English word?

Mr. Justice BLACKBURN: Every one knows the meaning of the English word. He says, in this particular way, it is used as a trade mark.

Mr. FIELD: "Best" is a trade mark?—A. It is.

*Re-examined by Mr. SEYMOUR.*

Q. "Best" is a trade mark, and "Triangle Best" is known in the trade as pointing to this particular composite article?—A. Decidedly.

Mr. Justice BLACKBURN: I just want to be quite sure about this. I gather from you that you say that until this trial it was quite a surprise to you to find that there was 20 per cent. of sesamé in this?—A. I did not know before, but I knew about the bran.

Mr. Justice BLACKBURN: I know; you have told us about that.

Mr. SEYMOUR: Will you ask him, my Lord, whether it alters his opinion of the cake?

Mr. Justice BLACKBURN: I do not think that bears upon the issue at all; but I understand him to be equally clear as to telling people how it was manufactured.

Mr. SEYMOUR: I wish your Lordship would ask him that question.

Mr. Justice BLACKBURN: No, I will not. I asked a question which I thought was left unasked, in order that there might be no mistake about the matter. Go on with the next witness.

Mr. GLOVER sworn: *examined by Mr. SEYMOUR.*

Q. You are a merchant, I think, at Warwick?—A. Yes.

Q. Have you dealt largely, and supplied customers largely, in your own and the surrounding counties, with linseed-cake?—A. I have.

Q. When did you commence dealing with Messrs. Ayre, Brothers?—A. About six years back, I should think.

Q. Did they introduce to you this Triangle Best?—A. They did, in 1868.

Q. Where did you see them—at Hull, or did they see you at Warwick?—A. At Warwick.

Q. You saw Mr. Ayre, I believe—did you commence dealing with them for the supply of that cake?—A. We did.

Q. What is the "Triangle Best linseed-cake" known as in the trade?—A. As a second quality of cake.

Q. Have you bought pure linseed-cake?—A. We have.

Q. What was said by Messrs. Ayre to you about this cake?—A. It was offered to us in the place of a second quality that we had been having before, which we had had great complaints about. Since that time—since 1868—I think we have sold about 300 tons a year of this same quality, and we have not had a single complaint.

Q. But besides pure linseed-cake, what other cakes are there that you know of as being sold in the market?—A. We have not sold anything but the second quality and the pure.

Q. Until you got this substitute for the second quality?—A. That is what I am speaking of—the "Triangle Best." That is what we are selling now.

Q. I thought you said that Messrs. Ayre supplied that to you in place of a second quality, of which you complained?—A. Yes.

Q. Do you recollect the name of that second quality that you had been having?—A. To my best recollection it was "B."

Q. Did you know anything from Mr. Ayre whether this was mixed or pure?

Mr. FIELD: Would you kindly—I ask you particularly, Mr. Seymour—oblige me by putting your questions in a different form?

Mr. Justice BLACKBURN: You really must not lead. You will pardon me for saying so, but I really do think Mr. Field is justified. You are rather too much telling the witnesses what you think, in place of asking them what they say. If you ask him what it was that passed between them he will tell you.

Mr. SEYMOUR: Then you have heard the question—do you recollect what did pass between you and Mr. Ayre about this cake?—A. I do not quite. It was explained to us what cake this was. There was a "K Pure" cake offered, and this Triangle cake at the same time.

Q. That is what I wanted to know from you, Mr. Glover.—A. I bought it understanding quite what the cake was, and when I have sold cake I always sold from sample. We have had a "K Pure" cake, and we have had a "Triangle" cake.

Mr. Justice BLACKBURN: You are asked what passed—you say it was explained. You are asked what it was explained to you to be.—A. Well, I

cannot quite recollect, my Lord, except that it was explained to be a mixed cake.

Mr. SEYMOUR: And did you buy it knowing it to be a mixed cake?—*A.* We did.

*Q.* How much did you pay Messrs. Ayre last year?

Mr. FIELD: What does it matter?

Mr. SEYMOUR: I think it was from 3000*l.* to 4000*l.*

The WITNESS: I do not know exactly the amount, but about 300 tons we had from Messrs. Ayre.

*Q.* And are you dealing now in that cake?—*A.* We are, very largely, and our customers take that cake in preference to “K Pure” cake, at a difference of 25*s.* per ton.

*Q.* Had you some of this cake in the month of February last?—*A.* We had. On the 6th February we had five tons; on the 14th we had two five tons; and on the 16th we had five tons.

*Q.* That is, 20 tons altogether in the month of February?—*A.* That is, 20 tons in a fortnight.

*Q.* You had two lots of 5 tons on the 14th?—*A.* Yes.

*Q.* And did they go out among your customers?—*A.* It was sent out, to the best of my recollection, to about 20 of my customers.

*Q.* Have you had a single complaint from any of them?—*A.* I have not had a single complaint from any one.

*Q.* And do you believe it to be a wholesome, nutritious cake?—*A.* I do.

*Cross-examined by Mr. FIELD.*

*Q.* Can you tell me what it was Mr. Ayre told you as to the make of this cake?—*A.* I cannot recollect.

*Q.* Give me your idea—you can recollect something about it, I suppose—what did he say to you about it?—*A.* Well, I cannot recollect exactly the words, but it was explained to me as being a mixed cake.

*Q.* What did he say to you—cannot you give me an idea—not the exact words—did he tell you what the mixture was, or what the nature of the cake was?—*A.* Well, I understood it was a mixture of bran and linseed.

*Q.* Did he tell you that?—Yes.

*Q.* Then do tell us—you see you do recollect—now tell us what it was he did tell you?—*A.* I do not recollect exactly what passed between us.

*Q.* Did he tell you there was sesamé in it?—*A.* Well, I cannot recollect.

*Q.* Surely you can tell us?—*A.* I cannot recollect four years back. I have been selling it for a good cake, and it has given great satisfaction.

*Q.* I am perfectly well aware of that; but did he tell you there was 50 per cent. of sesamé in it?—He did not. Nor was there 50 per cent either.

*Q.* Did he tell you there was any sesamé in it?—Well, I cannot recollect whether there was any sesamé mentioned or not.

*Q.* You really mean to tell the jury you cannot recollect yes or no?—*A.* I cannot recollect whether it was mentioned or not.

*Q.* The cake that you say it was in lieu of was marked “B”?—*A.* It was “B.”

*Q.* Was that Blundell’s?—*A.* I do not know the maker—it was offered to me by Messrs. Ayre, Brothers.

*Q.* Do you mean to say you do not know whose trade mark “B” is?—*A.* I do not.

*Q.* What was the matter with that cake of which your customers complained?—*A.* It was very bitter.

*Q.* What was it that made it bitter?—*A.* Well, I do not know.

*Q.* You do not know?—*A.* No.

Q. Is linseed bitter?—A. It must have been some kind of seed that was put into the cake—it was a mixed cake that I was buying.

Q. What was it that made the cake bitter—you come here to tell us all about the trade and as knowing all about these cakes—what was it that made the cake bitter?—A. I am not a maker of cake. I sell cake which is offered to me by Messrs. Ayre, Brothers. I take it upon their recommendation.

Q. What was it that made the cake bitter?—A. I cannot say.

Q. Is linseed bitter?—A. I cannot tell what made the cake bitter.

Q. Is bran bitter?—A. I cannot tell what made it bitter.

Q. To what extent did you have complaints at that time from your customers about that cake?—A. I cannot recollect exactly—we had several complaints.

Q. Did it hurt the cattle?—A. Not that I am aware of.

Q. What were the complaints with reference to the cattle?—A. It cannot be supposed that the cattle would say it was bitter.

Q. I do not suppose that, but what did your customers say?—A. The cattle would not eat it.

Q. Yes, but, still, I do not know why, because the cattle would not eat it, you infer it was bitter?—A. I could tell if I tasted it.

Q. Did you taste it?—A. I did.

Q. How much did you taste?

Mr. Justice BLACKBURN: Is not that wandering a good deal from the issue? The WITNESS: Well, I should not be likely to eat much of it.

*Re-examined by Mr. SEYMOUR.*

Q. Do you know the taste of rape?—A. I do not—I do not deal in rape-cake.

Q. The cake that the complaints were made of, had you got that from Messrs. Ayre?—A. We had that from Messrs. Ayre.

Q. Do you know what it is called?—A. "B Genuine."

Mr. Justice BLACKBURN: There is in Messrs. Ayre's circular now one marked "B Genuine" which is one of those of the second quality. I believe we heard whose trade mark it was, but I do not know that it much matters.

Mr. SEYMOUR: He said the rape made it bitter.

JOHN SPETCH, Foreman to Messrs. AYRE, *examined by Mr. CAVE*, deposed to going to Booth Ferry, and seeing the eight tons of cake there that had been rejected by Mr. Wells, that some of it was put into bags and sealed, and sent to Hull and given by the witness and Stevenson to certain cowkeepers.

GEORGE MASON, of Chapman Street, Hull, cowkeeper, sworn: *examined by Mr. CAVE*, deposed to receiving a little over a hundredweight of cake in a sealed bag from Spetch and Stevenson, and his examination then proceeded as follows:

Mr. CAVE: Did Spetch and Stevenson give you instructions what to do with it?—A. They did not.

Q. You did with it what you considered right?—A. I gave it to my cattle, the same as I should have done any other cake.

Q. How much did you give them?—A. Half a cake a day.

Q. And did you continue to do that as long as it lasted?—A. I did.

Q. How long would that be?—A. I did not take any particular notice—probably about five days.

Q. Did the cows eat it?—A. Decidedly so.

Q. And did they appear to do well upon it?—A. They did quite as well as on cake I had been giving them previously.

Q. What had you been giving them previously?—A. Pure cake and cotton, in about equal quantities.

Q. You say they did well upon it—it did not affect them in any way, did it?—A. No, not to my knowledge.

Q. How long have you kept cows?—A. About five years.

Q. Have you ever had your cows swollen?—A. No.

*Cross-examined by Mr. FIELD.*

Q. You had fed them upon pure cake and cotton?—A. Yes.

Q. What time of the day did you give it to them?—A. I gave it them in the evening.

Q. What time?—A. I cannot say what time. I do not always give it them at the same time exactly; it depends upon circumstances.

Q. About what time?—A. Sometimes about 7 o'clock in the evening, according as I get home.

Q. That is after the milking. What time do you milk?—A. I commence to milk between 4 and 5. I give them the cake usually after I return from delivering the milk.

Q. What other food did you give them besides cake?—A. You mean at that time?

Mr. Justice BLACKBURN: Yes.—A. At that time they were out at grass, and they would get a few malt grains and a bit of linseed-cake, and a little bran with the grains.

Mr. FIELD: Then the cake, the grains, and the bran, was all mixed together?—A. Decidedly not; cake was given them alone.

Q. Then how soon after would they get the cake?—A. Probably I should give them a few grains before I commenced milking them.

Q. Between 4 and 5 o'clock?—A. Between 4 and 5 o'clock; and if I got back from delivering the milk about 7, or sometimes a little later, I should then supper them up for the night (I keep them in in the night) and give them the cake.

Q. Did you give them anything with the cake?—A. Decidedly not.

Q. I thought you said you gave them grains, bran, and cake. When did you give them the bran?—A. Amongst the grains.

Q. At 4 or 5 o'clock?—A. Yes.

Q. And then at 7 gave them the cake?—A. Yes.

Q. Four pounds and a half. Did you break up the cake?—A. I broke it up with the hammer.

Q. What would they have in the morning?—A. Before going out, grains and bran also.

Q. Was that all they had all day long?—A. All they had besides what they picked up in the field.

Q. Oh! they were turned out to grass?—A. Yes.

GEORGE ROUNDTREE, sworn: *examined by Mr. SEYMOUR.*

Q. Are you a cowkeeper?—A. Yes.

Q. And have you been so for some 22 years?—A. Yes.

Q. Did you get some cake from Mr. Stevenson?—A. Yes.

Q. I think you got 1 cwt.?—A. Yes.

Q. And did you give it to your cows?—A. Yes.

Q. How many cows?—A. Five got it.

Q. How much did they get?—A. A good half a cake every day.

Q. And did you continue to give it them while it lasted?—A. Yes, every day while it lasted.

Q. Did it agree with your cows?—A. Very well; they looked very healthy.

*Cross-examined by Mr. FIELD.*

Q. What time in the day did you give it your cows?—A. I gave it in the morning.

Q. What time in the morning?—A. About 7 o'clock; between 6 and 7.

Q. What did you give them with it?—A. We gave them bran to milk with.

Q. How much bran?—A. Just a little, perhaps 2 or 3 lbs.; just a little to milk with.

Q. Did you mix that with the cake?—A. No.

Q. Then you gave them the bran and the cake almost together?—A. Yes, we gave them the cake soon afterwards.

Q. How soon after the bran did they get the cake?—A. About half-an-hour afterwards.

GEORGE WILLIAM SMITH, sworn: *examined by Mr. CAVE.*

Q. Do you manage your father's business?—A. Yes.

Q. And is he a cowkeeper?—A. Yes.

Q. Do you remember getting a bag of linseed-cake from Mr. Spetch and Mr. Stevenson?—A. I do.

Q. How many cows do you keep?—A. Six.

Q. Did you give the cake to your cows?—A. Yes.

Q. How much did you give them?—A. About a cake among six.

Q. Did you go on giving it them till it was all gone?—A. Yes.

Q. Did they appear to do well upon it?—A. Yes.

Mr. FIELD: I have nothing to ask him.

Mr. HORNBY, sworn: *examined by Mr. SEYMOUR.*

Mr. Justice BLACKBURN: They are not cross-examining. I suppose the other cowmen will say much the same.

Mr. SEYMOUR: That was my reason, but still, as I gave the names—

Mr. Justice BLACKBURN: I do not know that there is any harm in calling him; but, at the same time, I do not know that there is any good.

Mr. SEYMOUR (to the Witness): Are you also a cowkeeper, and did you get some of it and give it to your cows?—A. Yes.

Q. Did it agree with them?—A. Yes, I wish I had some more.

Q. How many cows did you give it to?—A. Three.

Q. What time of day?—A. At night.

Q. Did you mix anything with it?—No.

Q. What had they had just before?—A. I gave them a bit of bran.

Q. How much bran?—A. About half-a-peck apiece.

Q. And did you continue giving it, while it lasted, from day to day?—A. Yes, I did about a fortnight.

Q. And never saw anything in them the worse for it?—No, they were the better for it.

Mr. GEORGE HOLMES, sworn: *examined by Mr. SEYMOUR.*

Q. Are you a member of the Royal College of Veterinary Surgeons?—A. I am.

Q. And have you practised your profession as a veterinary surgeon for many years?—A. I have.

Q. For some years, I think, you were abroad in India?—A. Yes.

Q. Attached to —?—A. To Messrs. Cooke and Company, as well as to the Body Guard of India.

Q. And had you charge of the horses—the cavalry?—A. I had.

Q. And since your return from India where have you principally carried on your business?—A. Beverley—before I went to India—in Thirsk.

Q. And between your experience before you went to India, and since your return from India, in the treatment of cattle, how many years' experience can you recall?—About 32 years.

Q. Have you had a large personal practical experience in the diseases of cattle?—A. I have.

Q. Have you in your time treated cases of hove or tympanitis?—A. I have.

Q. Have you been in Court during the whole of this trial, Mr. Holmes?—A. I have.

Q. Having heard all the evidence that has been given, have you formed an opinion as to the cause of the death of Mr. Wells's cow?—A. I have.

Q. And as to the cause of the ailments that affected the other cattle?—A. I have.

Q. What is that opinion?—A. That opinion is, that the cause of the change that took place, that is to say, the cause of the illness of these animals was the cause of having a food that the stomach had not been used to, for some ten days or a fortnight, I believe, was the time stated. The mangold-wurzel and turnips just at this time of the year contain a great deal of moisture. From the 7th to about the 18th of February there was an immense quantity of moisture, and I think I named that there was a great deal of moisture this winter, and the weather being very mild little sprouts made their appearance very abundantly both from wurzel and from the turnip, and so large have some of these sprouts been that they have actually grown out into leaf. So long and large have some of these sprouts been that they have broken out into green leaf. The wurzel, I believe it is well known, is charged with a great deal of sugar. So much for the particular food that these animals had been taking up to the time that the cake was introduced. When this cake was first given to them, instead of having a smaller quantity which is recommended to be given, they commenced at first with a larger quantity.

Mr. Justice BLACKBURN: I do not understand you. I never heard of anybody recommending a smaller quantity, nor have I heard that there was ever a smaller quantity than this given.

The WITNESS: I may observe, my Lord, that every farmer that is in the habit of commencing with cake invariably commences with two or three lbs. of cake, and then running on to a larger quantity.

Mr. Justice BLACKBURN: Very well, wait a moment; that I understand.

The WITNESS: They commence with a smaller quantity, say from two to three or four lbs., and then they will increase from that small quantity by degrees up to 14 lbs. a day for the same animal. And to this sudden change, in the case of the animals of Mr. Wells, I attribute the sole cause of the symptoms of these animals generally, and their showing the peculiar symptoms that they did. I believe that was in consequence of the wurzel, as I said before, being so charged with moisture, and from these sprouts being extensively thrown out, and also that there is so much sugar in the mangold that when this food has been brought into contact with fresh food—with so much as 6 or 7 lbs. of linseed-cake—there has been a fermentation set up very quickly; gas quickly follows, and hence the distension that we hear of; so much so that we are told the animal can scarcely breathe or move, and the tongue is protruded. This is what I consider to be the cause of the illness of the animals in question; but in all cases in beasts you may give other ingredients, and, if they have not been used to it, it will produce the same effect. I have seen instances, but not to such an extent. For instance, I have seen

barley or barley-meal in one feed given to animals that are stall-fed produce the same effect. I have seen pea-meal also.

*Q.* You say you have seen the effect produced by barley or barley-meal?—*A.* In one feed I have seen it produce the effect.

*Q.* Produce tympanitis?—*A.* Yes.

*Q.* And accompanied by the same symptoms as in this case?—*A.* By precisely the same symptoms as we see in this case.

*Q.* In life and *post mortem*?—*A.* Yes.

*Q.* Can you give me any other illustration? As I understand, you are now speaking from your own practice?—*A.* Of my own practice. I have seen it when a beast has been eating wurzel, and swede turnips, and straw.

*Mr. Justice BLACKBURN:* Did I understand you to say that, in the case of the barley-meal, the animals were in the field or tied up?—*A.* Animals stall-fed. I have seen it also when they are eating wurzel, or turnips, and wheat-straw. I have seen when wheat-straw has been substituted for barley-straw, or *vice versâ*, that it has had precisely the same effect as what I have named.

*Mr. SEYMOUR:* Resulting in tympanitis with these same symptoms?—*A.* Yes, I have seen the same thing occur from changing wurzel or turnips to potatoes.

*Q.* Was the change of wurzels for potatoes that you mention in the case of stall-fed cattle?—*A.* Yes.

*Q.* Did you say potatoes substituted for wurzel, or wurzel for potatoes?—*A.* Potatoes substituted for wurzel—a change of food.

*Q.* You have seen tympanitis resulting from that?—*A.* Yes, I have also seen the same effect produced by giving grains on the first or second occasion. I have seen them produce exactly the same effect as wurzel.

*Q.* And is this a frequent disease among cattle?—*A.* A very common disease.

*Q.* Are there known instruments of surgery that are kept for the purpose of being used in such cases?—*A.* Yes, and my opinion is that if it had been used on this occasion we should not have heard of a cow dying.

*Q.* There is an instrument that can be used for making an incision in the stomach and relieving the gas?—*A.* Yes.

*Q.* And is that generally known among cattle-doctors?—*A.* Yes, I believe it is pretty generally known.

*Mr. Justice BLACKBURN:* It was known as long ago as the time of Sir Walter Scott's novels, for I remember a *simile* that he used in one of them—"Like a cow that has been fed on wet clover, and given a jag to let the wind out." I think we may take it for granted that every man on the Jury perfectly well knows that cows sometimes get hoven.

*Mr. SEYMOUR:* Is your opinion affected by the fact that a number of these beasts all treated in the same way showed the same symptoms?—*A.* Yes.

*Q.* Do you attach anything to the fact that there is a plurality?—*A.* Nothing more than I have named.

*Mr. Justice BLACKBURN:* What is it that you have named?—*A.* I attach, my Lord, very great importance to the wurzel on this occasion being very much charged with moisture.

*Q.* That I have understood, but I understood *Mr. Seymour's* question which he now asks you to be this—Whether you attach any weight to the fact that a good many cows fell ill at the same time?—*A.* No.

*Mr. SEYMOUR:* The conditions being the same, do you attribute to the same cause the illness of the cattle?—*A.* I should; only that where the disease was not so markedly developed it was that they had had a smaller quantity of the cake.

*Q.* For instance, you have known of cases of tympanitis and distension from taking clover?—*A.* Oh, that is a very common occurrence.



Q. If half-a-dozen cows went into a clover-field at a time, would you expect them all to suffer more or less according to the quantity they took?—A. Certainly I should.

Q. We have heard of the condition of the cattle at Airmyn Pastures, and of the cattle which took 3 lbs. only at Sancton, not showing any signs of disease?—A. Yes.

Q. Does that tend to confirm your opinion?—A. It does.

Q. You do not agree, then, of course, as I take it, with the suggested theory of there being any vegetable poison in the cake?—A. Most certainly not.

Q. Have you anything to add upon this subject as to the reason for not accepting the theory of the poisoning?—A. I think I see sufficient cause from what I have named. I think it is easily accounted for. It is well known in the country that it matters not scarcely what kind of food you give them; but cattle are subject to this distension when fresh food is given to them, if it is not given with the precaution of using small quantities at first.

Q. We have heard of the cow in this case dying in about three-quarters of an hour from the time that she took the food. Has that any importance in your mind upon the question of whether she died from poisoning or from tympanitis produced by the cause you assign?—A. My impression is that the cow died entirely from giving her the oil that we heard of. I firmly believe—it is my opinion—that that cow, when the oil was given to her, was not in a fit state to receive anything of the sort. We hear that her tongue was very much protruded, and that she was swollen up as far as possible; it was impossible for her under these circumstances to receive this oil. I consider that the oil went down the windpipe and caused the death of the animal—that is my impression.

Q. Your treatment would have been an instrument?—A. Immediately; it would have been the last thing I should have thought of to give anything in the form of medicine in such a state of circumstances.

Q. Suppose a poison to be taken into the system of a cow, what time do you think it would take to produce any results?

Mr. Justice BLACKBURN: I do not think it was suggested that this was a case of poisoning in that way, by taking it into the system. What was suggested on the part of the Defendants by Mr. Simonds was that something—he does not pretend to say what—that something in the cake acted as a poison on the nerves, paralysing temporarily the action of the stomach. That is very different from being taken into the system.

Mr. SEYMOUR: Well, I am glad, if your Lordship takes that view, to be relieved from combating that hypothesis.

Mr. Justice BLACKBURN: You are attacking a thing that has not been set up: it has not been said that there was poison taken into the system—that has not been suggested.

Mr. SEYMOUR: Not by Professor Simonds, but I certainly understood my friend to suggest it. However, I will not argue further with your Lordship upon it. I am glad to be relieved from having to meet that theory. (To the Witness.) Now we will come to the other. Do you think that dodder or arnel, which we have heard of as being discovered under the microscope, could disturb the action of the rumen so as to stop its peristaltic motion?—A. My knowledge is so slight on the subject I should not like to venture to give an opinion. I only know that dodder is used extensively as a food for the human subject.

Q. You do know as a fact that it is used extensively as food?—A. So I am told.

Q. Do you agree with Mr. Simonds in what he said, or is there, in your opinion, any foundation for attributing the death to any foreign cause other than that you have mentioned?—A. I scarcely know how to answer that

question. You ask me, do I agree with Mr. Simonds: upon what point do you mean?

Q. As to this suggested interference with the nerves of the rumen?—A. I most certainly do not agree with him on that point.

Q. Have you anything else you would like to add?—A. No, I do not know that there is.

Q. Then I may take it you have assigned a cause which satisfies you was the cause of the death of this animal?—A. As a practical man, I have.

*Cross-examined by Mr. FIELD.*

Q. In your judgment the cow died from the oil being administered through the windpipe?—A. My judgment is that the cow would not have died so suddenly had not oil been given to her.

Q. I thought you said that in your opinion the cow died from the oil which went down the windpipe?—A. In my judgment the oil choked her.

Q. Went down the windpipe?—A. Most likely it would—if it choked her at all it would.

Q. Then why did not you answer me? Now, in that state of things, would not Professor Simonds have found oil in the windpipe and bronchial tubes?—A. I do not think so at all.

Q. Do not you think so—what would become of the oil that went down the windpipe—the animal died you know?—A. The small quantity of oil that would go down the trachia—

Q. How much do you calculate would go down the windpipe?—A. Half an ounce or an ounce. Mr. Simonds may laugh at my observations, but it would be much better if he did not do so.

Mr. Justice BLACKBURN: It would be much better for you to attend to the questions and answer them: and, Mr. Field, do give him time to answer the questions.

Mr. FIELD: Will you tell me how much oil you calculate went down the windpipe?—A. I cannot say how much oil went down, but it takes but a small quantity to choke an animal in that state.

Q. Whatever quantity it would take to choke an animal in that state, the animal dying immediately, do you mean to tell me that Professor Simonds would not have found the oil in the windpipe?—A. I say very probably not.

Q. Ought he not?—A. No, I do not think he ought. It is very probable that, looking at the circumstances of the case, he would not look at the trachia at all.

Q. But if he had looked at the trachia, would he not have discovered the oil?—A. No, in the small quantity I do not think he would have discovered it.

Q. When did you first mention to the gentleman who instructs my learned friend that in your judgment the cow died from the oil going down the windpipe?—A. I formed my opinion from the observations made and the account of the symptoms given.

Q. You were present in Court when the witnesses were examined and when Professor Simonds was examined?—A. Yes.

Q. And you were sitting behind my learned friend?—A. Yes.

Q. Then, in your opinion, was the mangold the sole cause of the tympanitis?—A. I believe the mangold was the operating cause.

Q. The sole cause?—A. I do not mean to say the sole cause, but if the cake had not been given these symptoms would not have shown themselves so quickly.

Q. You limit it to the mangold?—A. I consider it the predisposing cause.

Q. Do you attribute it to mangold, or turnips, or potatoes?—A. To mangold, or the turnips and potatoes too, if you like.

Q. It is not a question of what I like, it is a question of your judgment against Professor Simonds?—A. My answer is that the mangold is, perhaps, the most predisposing cause of the three.

Q. The mangold, you say, was very moist?—A. Yes.

Q. And very sugary?—A. Yes, there is a considerable quantity of sugar.

Q. Why had not the mangold itself produced tympanitis?—A. Because it had had no fresh food introduced into the stomach for some time?

Q. You have heard that these beasts were in the habit from October, down to five days before the administration of this cake, of having mangolds and turnips in precisely the same way that they had it on the day in question.

Mr. Justice BLACKBURN: I think, Mr. Field, it was ten days.

Mr. FIELD: No, my Lord, the cows only had mangold.

Mr. Justice BLACKBURN: True, the cows.

Mr. FIELD: They were in the habit of having mangold and cake down to within five days of the 16th February, exactly in the same way as they had it on the 16th? Supposing the animal to have been fed from October down to within five days of the day when this cake was administered, in precisely the same manner as the cake was administered on that day, do you mean to say that was such an alteration of food as would cause tympanitis and the consequences you have heard?—A. I mean to say that when the stomach has been deprived of certain ingredients, whether for four, five, six, or ten days, when you want to begin that ingredient again it is proper that you should give it in a smaller quantity when you first commence.

Q. Will you oblige me by answering my question?—A. I think I have answered your question.

Q. No you have not. I put the question to you of an animal being fed in precisely the same manner up to within five days of the 16th, and I ask you whether in your judgment 6 lbs. of cake administered on the 16th under those circumstances would produce tympanitis; supposing, of course, the cake to be ordinarily good cake?—A. I mean to say that that substance of cake being added, being a fresh ingredient, would produce those symptoms.

Q. Under those circumstances?—A. Yes.

Q. Now, with regard to the beasts, we heard they had turnips in the morning, and did not have their cake till the afternoon; but, in your judgment, does that make any difference?—A. They had a bushel of turnips in the morning, no mangold at all, and at 2 o'clock 7 lbs. of cake, and, I believe, very shortly afterwards—

Q. Would you please answer the question? In your judgment what produced the illness in those animals?—A. The cause was having 7 lbs. of cake—having the turnips given so short a time after the cake had been given.

Q. No, it was in the morning?—A. But I am speaking of the afternoon.

Q. I am asking you, with turnips given at half-past 7 or 8 in the morning, after picking over the straw and cake given at 2 o'clock, what do you say was the cause of the tympanitis in those animals?—A. I mean to say that if the turnips had been given in the morning, and the cake in the afternoon, and no other turnips had been given shortly afterwards, those symptoms would not have been shown.

Q. Will you tell me what, in your judgment, was the cause of those animals falling ill. I do not want you to go on a wrong hypothesis because the witness said that, as he was going round and giving them their feed of turnips, afterwards he found the animals were very ill. Therefore do not let there be any mistake?

Mr. Justice BLACKBURN: We must deal with this witness upon what he

supposes to be the facts. Do I understand you that you think that if (supposing the fact, I do not say whether it is so or not) that if the turnips were given in the morning, and the cake not given till 2 o'clock, that could not have produced hove unless there were turnips given nearer the time that the cake was given either before or after?—*A.* Unless turnips were given again, I consider those symptoms would not have shown themselves. If no other turnips had followed the cake in the afternoon, or so near hand to the cake again, those symptoms would not have shown themselves.

Mr. Justice BLACKBURN: Very well, whether the turnips did follow or not we will see by looking back at the evidence when the time comes.

*Re-examined by Mr. SEYMOUR.*

*Q.* What interval between the turnips and the giving of the cake would be consistent with the view you take?—*A.* Two, or three, or four hours would do.

*Q.* Then if turnips were given two, or three, or four hours before, and then the cake was given in this quantity, in your opinion might the evil consequences follow?—*A.* In my opinion the fermentation would take place in the stomach.

Mr. Justice BLACKBURN: Just let me see, in order that we may have no mistake about this; do I understand you that four hours is the maximum—that if turnips had been given as much as six hours before, it could not have produced the result you have mentioned?—*A.* I should scarcely like to say that, but I am taking it as a maximum. I should judge so. It just depends upon how soon the animal begins to ruminate; it entirely depends upon that.

*Q.* But what would be the maximum time in your opinion as a man of skill and a practical man. I do not ask you what is conceivably possible, but what in your opinion would be reasonably probable as the maximum time—do you mean that four hours is the maximum?—*A.* Well, I should say so.

Mr. JOSEPH FREEMAN sworn: *examined by Mr. CAVE.*

*Q.* Are you a veterinary surgeon living at Keyingham, in Holderness?—*A.* Yes.

*Q.* I believe you obtained your diploma in 1859?—*A.* I did.

*Q.* Previously to that, had you been a pupil of Mr. Simonds?—*A.* Yes.

*Q.* Was your father a veterinary surgeon?—*A.* Yes.

*Q.* And have you had experience from your boyhood?—*A.* Yes.

*Q.* Have you an extensive practice at the present time in Holderness?—*A.* Yes.

*Q.* I believe there is a good deal of grazing and feeding there, is there not?—*A.* There is.

*Q.* Have you been in court and heard the evidence which has been given in this case?—*A.* I have.

*Q.* And having heard the evidence which has been given, to what cause do you attribute the death of this cow?—*A.* The primary cause, I believe, was indigestion.

*Q.* How brought on, in your opinion?—*A.* Through a change of food.

*Q.* And is your opinion affected by the fact that a number of animals were affected in a similar manner at the same time?—*A.* No.

*Q.* In the course of your practice have you seen cases of tympanitis?—*A.* Many a one.

*Q.* From what causes does tympanitis arise generally?—*A.* Almost as many causes as the food they partake of.

Q. Will you explain how that is?—A. Sometimes from an overgorged stomach tympanitis will arise, and sometimes by fermentation of the food partaken of—sometimes by the food partaken of.

Mr. Justice BLACKBURN: Are you saying fermentation as a separate thing from these? You said sometimes it was from an overgorged stomach, and sometimes from fermentation from the food partaken of. Do I understand you as putting the fermentation as a separate cause from the food partaken of, or as merely a thing that accompanies it?—A. Separate.

Mr. CAVE: An overgorged stomach, I suppose, arises from taking too much?—A. Yes.

Q. Fermentation—what does that arise from?—A. It will arise from the stomach of the cow not performing its proper function.

Q. And what is that caused by?—A. Various causes.

Q. Will you mention some of them?—A. I have known cases arise from the animals having pieces of wire or pins or needles in the stomach.

Q. Then you also spoke of it as arising from the food partaken of?—A. Yes.

Q. Will you explain in what cases that is?—A. By having turnips or wurzels or potatoes, or from any vegetable matter.

Q. Under what circumstances does the food bring about tympanitis?—A. By the fermentation and disengagement of gases.

Q. I understand that, but I want to know under what circumstances—when would the food bring that on?—A. Well, it might arise almost at any time.

Q. Do you find a change of diet have any effect?—A. Yes, frequently.

Q. Can you give me instances in which change of diet has brought on tympanitis?—A. I have known several—from eating potatoes, or from eating turnip-tops, or wurzel-tops, or wurzels themselves—from eating clover.

Q. Does it occur more frequently in stall-fed cattle, or in cattle in the fields?—A. In stall-fed cattle.

Q. Now, with regard to stall-fed cattle, are they more subject to it when a change of food takes place?—A. Decidedly so.

Q. The ordinary remedy is to make an incision in the flank, I believe, is it not?—A. That is not my practice.

Q. What is it?—A. Either to put down the probang to relieve the gas—

Q. That is a hollow tube which allows the gas to escape?—A. Yes—to give medicines that would neutralize the gas, or to puncture the rumen with a trochar through the side

Mr. Justice BLACKBURN: You say either medicine to neutralize the gas, or to puncture the rumen through the side?—A. Yes, my Lord.

Q. That is what I understood Mr. Cave to ask you first, but I dare say it was the use of the word “flank” that made the difference.

Mr. CAVE: Is the administering of oil the proper thing to do?—A. Yes.

Q. At what stage?—A. It is very frequently given in the first stage by some people.

Q. For what purpose?—A. Well, I cannot tell you: it seems to have a wonderful effect in allaying the gases—it is the same as pouring oil upon water.

Q. Would it be proper to give it at a time when the tongue was out and the animal was apparently struggling for breath?—A. It would not be my practice.

Q. Would you think it proper?—A. By no means.

Q. Do you find highly-bred cattle more or less predisposed to disease than ordinary cattle?—A. I believe they are more predisposed.

Q. Do you agree with what Mr. Holmes has said with reference to the cause of death in this case, with reference to the change of food?—A. I do.

*Cross-examined by Mr. FIELD.*

*Q.* Mr. Holmes told us the cause of death in the cow was, in his judgment, the oil passing down the windpipe—do you agree with that?—*A.* That is not what he said. He said it hastened it, and caused the cow to die sooner.

*Mr. Justice BLACKBURN:* It is not of much consequence. Whatever it was that caused the animal to be ill is the more important thing. He thinks there was error of treatment in pouring the oil down the animal's throat undoubtedly, but that did not make it ill.

*Mr. FIELD:* You told my friend that sometimes it may be produced by food partaken of—I mean fermentation?—*A.* Yes.

*Q.* I suppose deleterious food is injurious—food of any sort which acts upon the nerves would produce it?—*A.* Yes, and good food as well.

*Q.* Will foreign substances, deleterious and injurious food, produce that effect?—*A.* No doubt they would.

*Q.* You say pins and needles would produce it?—*A.* I have found them in the stomachs of cattle afterwards.

*Q.* They will, in your judgment, produce the fermentation—produce tympanitis?—*A.* Yes.

*Q.* A piece of wire, I see you mentioned?—*A.* Yes.

*Q.* Did you see any reason to suppose that they were predisposed to disease down to the morning of the 16th? You have heard what happened to them, how they were taken up in September, and fed in the way you have heard?—*A.* Yes.

*Q.* And you think they were predisposed to disease?—*A.* Yes.

*Q.* What disease were they predisposed to?—*A.* The animals being high-bred, I believe are better cared for, and consequently they are rendered more liable to disease, and especially from being kept up during the winter in stall.

*Q.* What disease do you suppose they were predisposed to on the morning of the 16th?—*A.* Nine times out of ten we find it from disorder of the stomach.

*Q.* I ask you with reference to these animals, taking their food healthily on the morning of the 16th, in the way you have heard, what disease they were exposed to then—can you tell me that?

*Mr. Justice BLACKBURN:* I thought he had told you already. (To the Witness.) What was it you said about disordered stomach? I may not have understood you rightly, but I thought you said just now, in answer to Mr. Field's question, that high-bred animals, especially when tied up and stall-fed, were more prone to disease, and then you added something about disordered stomachs?—*A.* Did I say they were better cared for?

*Mr. Justice BLACKBURN:* Yes, I think you said that?—*A.* And consequently, I believe, more predisposed to indigestion from a change of food.

*Mr. FIELD:* Now, I will ask you the same question I asked Mr. Holmes,—Would four or five days' absence from cake be enough to cause tympanitis upon 6 lbs. of cake being administered, the animals having had mangolds in the morning and in the middle of the day?—*A.* I believe it would, or from any other kind of food.

*Q.* What other kind of food do you mean?—*A.* Tare-meal, bean-meal, bran, barley, oats.

*Q.* Given under what conditions?—*A.* Given after the animal has had its ordinary food.

*Q.* Suppose the same animals to have been without food again for a similar or longer period of time afterwards, and then to have taken their feed of cake and to have suffered no harm from it, does that alter your opinion at all?—*A.* No.

*Q.* Why not, if you have all the same elements existing—why did not that

affect them in the same way?—*A.* The animal might not be in that particular state of health which it was in previously. There is a peculiar idiosyncrasy, as Professor Simonds said, about animals that we are not able to understand.

*Q.* Answer my question—Does it alter your opinion if they were accustomed to the food, and then were without the food for a similar or longer period of time afterwards, and then to have taken their feed of cake and to have suffered no harm from it, does that alter your opinion as to the cause of their illness?—*A.* No, it might, or it might not.

*Q.* Why not, if the same conditions existed on the subsequent occasion as on the 16th of February?—Why did not the animals “indigest” then and blow up, and get ill and die?—*A.* I cannot tell you that, but they are not always in the same state of health.

*Re-examined by Mr. SEYMOUR.*

*Q.* Might not purging and treatment, and the care they had received for days previously, alter their susceptibility on the second occasion?—*A.* It would on that occasion, I believe.

*Q.* But, without theorizing or speculating as to the second occasion, from all that you have heard in this case, do you attribute the death of this cow and the injury to these cattle on the first occasion to tympanitis produced by the change of food?—*A.* I do.

**Mr. WILLIAM BROUGHTON, sworn: examined by Mr. SEYMOUR.**

*Q.* Are you a veterinary surgeon practising in Leeds?—*A.* I am.

*Q.* Have you had considerable experience in this neighbourhood and the surrounding counties?—*A.* I have.

*Q.* And among horned cattle chiefly?—*A.* Yes.

*Q.* Have you professionally attended many cases of tympanitis in grazing cattle, and also in stall-fed cattle?—*A.* I have.

*Q.* Have you found over-feeding, feeding too greedily, and alteration of food?—*A.* Yes.

*Q.* In the alteration of food which class, those out to grass or those stall-fed, are most disposed to suffer by the variation?—*A.* Stall-fed ones.

*Q.* And which are more liable, the common or the higher breeds?—*A.* The higher bred are more liable.

*Q.* Have you heard the evidence in this case?—*A.* I have.

*Q.* Bringing your experience to bear on the matter, and exercising the best of your judgment, what, in your opinion, was the cause of the death of the cow, and of the illness of the other cattle?—*A.* Indigestion, from change of diet partaken of in too large a quantity.

*Q.* Taking the interval of either a week or ten days since these short-horned cattle had been fed on linseed-cake, giving them even the purest linseed-cake to the extent of 7 lbs. after that interval, was that a safe or prudent course?—*A.* It was not a safe course, it was too large a quantity.

*Q.* And, as a practical man, without dealing in theories, is that sufficient to account for the death in this case?—*A.* It is.

*Cross-examined by Mr. FIELD.*

*Q.* Six pounds of cake, after the absence of it for six days, is too large a quantity of cake to give?—*A.* Yes.

*Q.* The same beast having had 6 lbs. from October downwards?—*A.* Yes, here being an interval.

*Q.* Of six days?—*A.* Yes, it was too large a quantity, I think.

*Re-examined by Mr. SEYMOUR.*

Q. Would the animal, in your opinion, eat more greedily when the fresh cake was given?—A. I should say so.

Q. And would the tendency under these circumstances be to produce fermentation and indigestion?—A. Undoubtedly.

Mr. JOHN CUTHBERT, sworn: *examined by Mr. CAVE.*

Q. You are a veterinary surgeon residing in Leeds?—A. I am.

Q. What are your qualifications?—A. I have the honour to be President of the Yorkshire Veterinary Medical Association.

Q. Have you had many years' experience in your practice?—A. I have.

Q. Especially with horned cattle?—A. Not especially with horned cattle.

Q. With cattle of all sorts?—A. With cattle of all sorts.

Q. Have you had experience in cases of tympanitis?—A. I have.

Q. And do you agree with the preceding witness that it is caused by over-feeding, feeding too greedily, and by alteration of food?—A. It is caused by indigestion.

Q. Arising from what?—A. From functional derangement of the stomach or stomachs.

Q. And what is the functional derangement of the stomach caused by?—A. Probably by overloading, or by want of nervous power in the stomach, of which overloading would partially paralyse the nerves.

Q. Does a change of diet affect cattle?—A. Very frequently.

Q. In what way?—A. By producing indigestion.

Q. Does that happen more or less with stall-fed cattle?—A. More with stall-fed cattle.

Q. And are highly-bred cattle more or less disposed to it than others?—A. I do not think the breeding makes them more disposed to the disease, but the management of them renders them so.

Q. Have you had instances of tympanitis arising from the causes you have mentioned in your own practice?—A. I have.

Q. Have you heard the evidence on this trial?—A. I have.

Q. In your opinion, what was the cause of the illness of Mr. Wells's cattle?—A. Indigestion in the first place.

Q. How caused?—A. The death was caused by elimination<sup>r</sup>(sic) of gas to the cow that died.

Q. How do you say the indigestion was caused?—A. By overloading the stomach.

Q. If cattle are kept without cake for some days, and then have it again, would they be likely to eat it more greedily?—A. Undoubtedly.

Q. Do you think giving 6 or 7 lbs. after an interval of five to ten days a safe thing to do?—A. I think it is an over-dose.

*Cross-examined by Mr. FIELD.*

Q. I believe your line of business is amongst horses, is not it?—A. Mine is a mixed practice.

Q. But principally amongst horses?—A. Principally.

Q. Do you attend cows?—A. I do.

Q. Was this case of tympanitis that you speak of with a cow or a horse?—A. It was a cow.

Q. Where was it?—A. Which case do you want?

Q. You say you have had cases of tympanitis; have you had tympanitis amongst cows?—A. Yes.



Q. And beasts?—A. Yes.

Q. Steers?—A. Not steers.

Q. Cows?—A. Yes.

Q. How many cases have you had?—A. I could not enumerate them.

Q. You have generally practised amongst cows, then, as I understand?—  
A. I have a general practice.

Q. Amongst cows and beasts?—A. Well I have most practice amongst horses, but my practice is a general practice.

Q. You talk about indigestion. Do you understand that the ruminating animals digest the same as a horse does?—A. Yes.

Q. The same?—A. Well they digest the same.

Q. What, with gastric juice?—A. Yes, with gastric juice.

Q. Is that your idea of it?—A. Yes.

Mr. Justice BLACKBURN: I do not think you understand the question. You do not mean to say there is no difference between an animal that chews the cud and one that does not?—A. Of course there is. One animal has only one stomach, and the other has four.

Mr. FIELD: Do you mean to say that the process going on within the rumen is equivalent to digestion?—A. Not at all.

Q. Well, you used the term "indigestion," that is the reason I asked you?—  
A. Not at all.

Q. Then, in your opinion, 5 or 6 lbs. was an over-dose of cake to give?—  
A. I think so.

Q. Under the circumstances of the case that you have heard with reference to all the animals and so on?—A. I do.

Mr. JOHN MITCHELL, sworn: *examined by Mr. SEYMOUR.*

Q. Are you a veterinary surgeon in Leeds?—A. The senior veterinary surgeon in Leeds.

Q. And I believe you have been in practice for something like thirty years?—  
A. Above thirty years.

Q. And are you a Cattle Plague Inspector for twenty-seven divisions?—  
A. I was appointed by the local authorities.

Q. Have you had, as a practical man, much experience among short-horned cattle and their diseases?—A. Very much experience indeed. I was brought up in Bedfordshire, and I had a great amount of practice in Bedfordshire and Northamptonshire.

Q. Among short-horned cattle all your life?—A. Yes.

Q. Have you had experience also in death or illness from tympanitis?—  
A. Many cases.

Q. Many cases in your own practice?—A. Scores of cases.

Q. Do you agree with the gentlemen who stood before you in the witness-box as to the predisposing causes of tympanitis?—A. I do, in every particular.

Q. An overcharged stomach and a sudden alteration of diet?—A. It is a very common cause of tympanitis; a very common cause.

Q. Do you also agree that stall-fed cattle, and the management of a higher breed, renders them more predisposed?—A. Mismanagement renders them more predisposed.

Q. Have you heard and attended to the evidence in this case?—A. I have.

Q. In your opinion, what was the cause of the death of that cow?—  
A. Indigestion, produced by an over-dose of food.

Q. Now, without reference to the quality of the food, suppose, after such an interval as there was here, that this cow was given 6 or 7 lbs. of pure

linseed-cake, in your opinion was that a safe or proper treatment?—*A.* It is an over-dose, I should call it.

*Q.* Can you mention any analogous cases in your own experience?—*A.* Not where cake has been the predisposing cause.

*Q.* Well, I would rather you gave me something else?—*A.* Where bean-meal or bran has been administered in improper quantities it is a very common cause indeed.

*Cross-examined by Mr. FIELD.*

*Q.* You say 6 lbs. or 7 lbs. is an over-dose; what quantity might have been safely given?—*A.* I should have begun with 2 lbs. or 3 lbs.

*Q.* 4 lbs?—*A.* Probably; perhaps 4 lbs.

*Q.* Perhaps 4½ lbs.?—*A.* Well, I am not able to judge to ½ a lb. in the weight.

*Q.* Well, you would not negative 4½ lbs.?—*A.* No.

*Re-examined by Mr. SEYMOUR.*

*Q.* But after the interval of a week, would starting with 6 lbs. in your opinion be unsafe?—*A.* I think so.

*Q.* Would 7 lbs. be still more so?—*A.* Oh, certainly.

*Q.* And in your opinion, is there sufficient cause, as a practical man, from that of this death without theorising or speculating?—*A.* Certainly.

*Mr. WILLIAM FERNLEY, sworn: examined by Mr. SEYMOUR.*

*Q.* Are you in practice as a veterinary surgeon in Leeds?—*A.* Yes.

*Q.* Have you heard the evidence given by the gentlemen who have been in the box before you?—*A.* Yes, I have; part of it.

*Q.* You have heard the last two or three witnesses, I believe?—*A.* Yes.

*Q.* And do you agree with them?—*A.* Yes, I do.

*Q.* Have you met with cases of tympanitis in your own practice?—*A.* Oh, a great many; hundreds of cases. It is a very common thing with cattle.

*Q.* Have you known any instances in which death by tympanitis has resulted from change of food?—*A.* Oh, yes, it is the commonest thing in the world; it is the commonest thing with cattle to have tympanitis from change in food, it does not matter what food it is; from one field of turnips to another will almost do it.

*Q.* You say from one field of turnips to another—a change from turnips produced by one field to turnips by another?—*A.* It will sometimes produce it.

*Q.* Where there has been a cessation of food for a particular time and then the food is given again, have you met with a case where tympanitis has occurred from the alteration under these circumstances?—*A.* Oh, yes.

*Q.* Within how short a time,—we have heard of from 5 days to a week or 10 days in this case. Can you tell me in your experience, within what time you have met with it?—*A.* Perhaps 2 or 3 days: the stomach gets into one groove as it were, and if you put it out of that groove by change of food, it does not so regularly digest it.

*Q.* You have known cases where food having been laid aside for 2 or 3 days, and then resumed, tympanitis has set in from the alteration?—*A.* Yes.

*Q.* Have you known cases in which the new food has been given 6 or 7 hours after ordinary food?—*A.* Yes, I have.

*Q.* Have you known tympanitis set in from that cause?—*A.* Yes, I have.

*Q.* Then do you agree that in this case the death and illness of these animals is referable to tympanitis, caused by the alteration of food?—*A.* By the simple change of diet.

*Cross-examined by Mr. FIELD.*

Q. What was the change of diet that took place in that case that you mentioned of 6 or 7 hours?—A. In what particular case?

Q. The case you mentioned—you say even after the lapse of 6 or 7 hours—  
A. I have not mentioned any particular case. I have known it in many cases.

Q. Do I understand you to assent to what Mr. Seymour has put to you, that you have known tympanitis to arise from a change in food in 6 or 7 hours? I could not understand what it was. What were the circumstances of that 6 or 7 hours' case?—A. I do not understand you at all.

Q. Well, I am sure I do not understand you. You say you have known after a lapse of 2 or 3 days a case of tympanitis to occur. What animal was that in?—A. I have known it in many animals.

Q. What animal was that case that you spoke of where it occurred after a lapse of 2 or 3 days?—A. If you had been giving this particular cake for 2 or 3 months and then left it off for 2 or 3 days, it would be unsafe to give it unless—

Mr. Justice BLACKBURN: You are asked, in the cases which you have relied upon in your practice in support of the evidence you gave as to the 2 or 3 days, what the animals had. What was it that was changed or rather discontinued? What were the circumstances of the case? That is what you are asked.—A. I do not remember.

Mr. FIELD: You do not remember any case?—A. Almost in any case.

Q. Then I must ask you this: Are you speaking of a particular case or are you giving your opinion?—A. I am speaking from my experience in many cases.

Q. Then will you give me one of the cases?

Mr. SEYMOUR: By way of illustration?—Q. I do not know that I can give you an illustration.

Mr. FIELD: You say, many cases. Will you give me one case? I want to test your evidence.—A. I do not know that I can give you one in particular.

Q. Surely you can give me one case—you speaking of having met with so many cases. Will you tell me what animal it was?—A. A cow, of course.

Q. Was it a cow? Why "a cow of course"? I do not know.—A. Well, it was a cow.

Q. Whose cow was it?—A. I do not know. I have not come here to call up any particular cases.

Mr. Justice BLACKBURN: I am afraid you are mistaken in that. You know you have told us from your experience, that even after 2 or 3 days the stomach gets into one groove and the change back produces tympanitis. Now, you are asked for a particular case in which you have known that—that is, in order to see how far you are justified in your generalization. Can you not remember any one case?—A. I cannot just now, my Lord, remember any particular case.

Mr. FIELD: Can you remember a single case, and will you tell me what the animal was and the food he had had—your knowledge of it—and how many days he was off his food?—A. I could concoct a case, if you like that.

Mr. Justice BLACKBURN: You are asked a real fact—if you can remember none, say so.

The WITNESS: I can remember none at all, because there are so many.

*Re-examined by Mr. SEYMOUR.*

Q. Do you remember the fact that you have met with such cases in your practice?—A. It is the commonest thing that we have to attend to in current practice—change of food, it does not matter how simple.

*Q.* How long have you been at your profession?—*A.* I started in 1860.

*Q.* And although you cannot at this moment recall the case of A., B. or C., can you state from your own knowledge that you have met with such cases?—*A.* Yes, I can scores of such cases.

*Q.* Have you taken the usual degree in your profession?—*A.* Yes.

*Q.* And have you given an opinion based both upon your experience and upon your reading?—*A.* It is from my own experience in fact, that I give it.

*Q.* I think you have been in practice since 1866?—*A.* Well, I got my diploma in 1866, but I was articulated before 1866.

*Q.* But you have been in practice since 1866?—*A.* I have been in practice since 1860. I went as an articulated pupil in 1860, and was four years apprenticed to Mr. Lecher of Ripon, and he was in one of the largest practices as a veterinary surgeon in the kingdom—in the cattle practice.

JOHN LOGDON, sworn: *examined by* MR. SEYMOUR.

*Q.* Are you in the employ of Mr. Kidd?—*A.* Yes.

*Q.* And I believe it has been your duty to superintend the landing and screening of the seed?—*A.* Yes.

*Q.* When the seed is landed where is it taken to?—*A.* It goes through a screen and upstairs.

*Q.* And when you have screened it, what becomes of the screenings?—*A.* Well, that screen that it goes through picks out the sticks, matting, stones and anything of that kind.

*Q.* And that is thrown overboard?—*A.* Yes.

*Q.* And then it is taken upstairs?—*A.* Yes.

*Q.* We have heard about elevators, and the spout and so on, do you work in the room where the bags of the siftings are kept that we heard of yesterday?—*A.* Yes.

*Q.* Is it your duty to take the siftings and put them into the bags?—*A.* Yes, I have all control over them.

*Q.* Have you control both over the putting them into the bags and supplying the bags afterwards if they are ordered?—*A.* Yes.

*Q.* We are told that the bags of siftings are used for mixing with ordinary cake, can they be used to mix with any other seed without your knowledge?—*A.* No.

*Q.* Do you know the article called "Triangle Best"?—*A.* Yes.

*Q.* Have you ever known any of the siftings to be used for mixing with "Triangle Best"?—*A.* No.

*Q.* Could that be used without your knowledge?—*No.*

*Q.* Would it be possible for that to get mixed with "Triangle Best"?—*A.* No.

*Q.* Why not?—*A.* Because they are not where the seed is, they are down away from it altogether.

*Q.* When you have the control of the bags and any of the siftings so wanted, what is done with them?—*A.* The seed that is mixed with it, the best seed, when we have occasion to mix some of these small seeds with that, the small seed is down below, and they entirely go into the elevators by themselves, and into the bin, so that they cannot get mixed with any other seed.

*Q.* And when that seed is used for "Triangle seed" how does it go?—*A.* It goes into the elevators, but it is upstairs.

*Q.* What is upstairs?—*A.* The seed that is used in the "Triangle Best."

Mr. Justice BLACKBURN: But is not the seed that is used for the "ordinary" also upstairs?—*A.* The small seeds are not.

*Q.* No, but the linseed, if I have understood the former witnesses aright, all

the linseed, whether it is used for "best," or "pure" or "ordinary," is upstairs?—*A.* Yes, all the linseed is upstairs.

*Q.* And it all comes down through the spouts, whether it is intended for the one or the other?—*A.* Yes, but there are different spouts; one for the seed for the "Triangle Best," and one for the seed for the "Plain Triangle."

*Mr. SEYMOUR:* Are they then kept distinct?—*A.* Yes, all the seeds are kept distinct by themselves upstairs.

*Q.* Have you ever seen rice-husks?—*A.* No.

*Q.* Or cocoa-nut?—*A.* No.

*Q.* Or the sweepings of warehouses put in?—*A.* No.

*Cross-examined by Mr. FIELD.*

*Q.* It could not possibly come there, such a thing could not possibly get into the cake at all?—*A.* No, not without my knowing.

*Q.* They could not. And you know all about it?—*A.* Yes, I know all about it.

*Q.* What are your duties?—*A.* My duties are to land the seed, and then, when I receive orders from the foreman, to put it into the bin, and direct how to put it in.

*Q.* What are you called?—*A.* "Foreman of the Chamber."

*Q.* You land the seed first?—*A.* Yes.

*Q.* And when the seed is first landed it contains the sticks and stones, and all sorts of impurities?—*A.* Yes, matting, &c.

*Q.* And sticks, and stones, and dirt of various descriptions?—*A.* There is not a great quantity of dirt attached to linseed.

*Q.* Do you receive the sesamé-cake?—*A.* No.

*Q.* Who is the man who receives sesamé-cake?—*A.* I believe he is in Court.

*Q.* What is his name?—*A.* Coggins.

*Q.* Where does the sesamé-cake come from?—*A.* I do not know anything about it. I have nothing to do with it.

*Q.* Does not that come into the mill?—*A.* I believe it does, but I have nothing to do with it.

*Q.* No, I know you have not. I am not going to say anything of the kind. About the sesamé-cake, what part of the mill does the sesamé-cake come into?—*A.* It comes into the bottom floor.

*Q.* It never comes upstairs?—*A.* No.

*Q.* Does it come into the mill ground?—*A.* No.

*Q.* Where is it ground?—*A.* You will excuse me, it comes into the mill, but not into the mill where the cakes are made.

*Q.* What mill does it come into?—*A.* The place where the machine is fixed, that is where it comes to be ground.

*Q.* Where is the "Buffum" machine?—*A.* Where the sesamé-cake is.

*Q.* That comes to the "Buffum" machine?—*A.* No, to the machine.

*Q.* You said the "Buffum" machine just now. When it comes into that machine is it broken up?—*A.* Yes.

*Q.* Who breaks it up?—*A.* Coggins.

*Q.* And when he does that what becomes of it then?—*A.* It goes into the mill. He is in Court.

*Q.* And we shall see him?—*A.* I have nothing to do with it.

*Q.* Do you mean to say you do not know what becomes of the sesamé-cake?—*A.* No, I have nothing to do with it.

*Q.* Where is the bran kept?—*A.* Upstairs.

*Q.* Oh, that is under your charge, is it?—*A.* Yes.

*Q.* Then when the seed is landed it is first of all sifted on the ground. Where does the first screening take place?—*A.* When I land it.

Q. When you land it where—what part of the mill?—A. On the foreshore.

Q. Then after that it comes upstairs into your chamber?—A. Yes.

Q. Are your duties limited to the foreshore and to the upstairs chamber?—A. Yes.

Q. You have nothing else to do with any other part of the mill?—A. No.

Q. Then upstairs in your chamber is kept the linseed that comes up. How often is it screened?—A. Three times—it goes through three screens.

Q. Can you give me the size of the meshes of the screens?—A. I cannot.

Q. Roughly; what is the widest and what is the narrowest—can you tell me?—A. Well, I cannot.

Q. You cannot tell me?—A. No.

Q. Then when the thing has gone through three screens, what becomes of the linseed?—It goes into the bin to be crushed, to be made into cake.

Q. I suppose all the linseed is of the same quality?—A. No.

Q. Oh, there are different qualities of linseed?—A. Yes, there are.

Q. Do you recollect the linseed coming in with the 'Labrador'?—A. No, I do not remember any ship—I have nothing to do with it at all.

Q. Do you recollect the quantity of linseed that came in in November?—A. No; I cannot call back to that time.

Q. I thought all the linseed was put together?—A. No, it is not.

Q. Then is there a division made of superior and inferior linseed?—A. Yes.

Q. Who makes that division?—A. We have a great quantity of room in the chamber.

Q. Who does it—you yourself?—A. Yes.

Q. It is your duty to separate the good from the bad?—A. If you will understand me, when I take in a good parcel of linseed, the foreman gives me orders to put it into such a place by itself, and I keep it there. By-and-by there will be a parcel come in that is not quite so good; well then I put it into another place; and by that means the parcels received are kept distinct by themselves.

Q. Then when some other comes in not quite so good again, what do you do with that?—A. We put it by itself.

Q. And who is the foreman who gives orders and selects which of the linseeds you shall put into one place and which in another?—A. Mr. John Stevenson.

Q. That is the same man we had here yesterday?—A. Yes, I suppose it is.

Q. I do not understand exactly—now is the best linseed used for any particular thing, because you said the linseed for the "ordinary" came down that one spout, and the linseed for the "pure" came down through the other spout—is that so?—A. Yes, but it is all one seed, but we mix those small seeds that we have.

Q. What seed do you mix the small seeds with?—A. When it comes through the three screens there are small seeds and sand, and those things come out through the small screens.

Q. What do you do with those small seeds and sand?—A. We put them into bags and take them down to the bottom floor, and sift all the sand out, and then we put the small seeds in proportion among the "Triangle" cake.

Q. That is done downstairs?—A. Yes, there cannot be any mixture without.

Q. Where are the bags kept with the small seed in?—A. They are kept in a small place to themselves, in a chamber by themselves.

Q. Down stairs, a lot of bags put together with the small seeds in?—A. Yes.

Q. I suppose anyone can go to them and take them out if he likes?—A. Yes, but he cannot put them in the bin without my knowing; he may take them away if he likes.

Mr. Justice BLACKBURN: It is not locked up, then?—No.

Mr. FIELD: And the bags are not tied or sealed?—A. They are tied.

Q. But not sealed, so that anybody can get at them?—A. He has nothing to do but to untie them.

Q. Are you there night or day?—A. Day.

Q. Who is in your place at night?—A. There is not anybody.

Q. Oh, there is nobody at night?—No.

Q. Then who mixes the small seeds at night?—A. I mix them before I go away.

Q. Where do you mix them?—A. Down stairs.

Q. You must have a large bin there to mix the seeds in. What quantity of seeds do you use in the course of the night?—A. Well, 10 lasts on "pure" like.

Q. And how much on "ordinary" cake?—A. Well, I cannot say.

Q. How much on "Triangle Best"?—A. Well, I cannot say.

Q. Then you mix the whole lot the night before?—A. The bins are made sufficiently large for me to get enough in in the daytime to serve the night well.

Q. Do those small seeds go into the "Triangle Best" as well as the others?—A. No.

Q. You are quite sure of that?—A. Quite sure.

Q. Then, if there are small seeds in the "Triangle Best," what do you say about it; where do they come from if they are found in it?—A. Well, they come with the seed.

Q. I thought you said it was screened?—A. It is screened.

Q. I thought you screened out all the small seeds?—A. No; not all of them.

Q. Well, if there is any wheat or rice husks, or husks of oats or barley in the cake, where does that come from?—A. There is none, because the screens will not admit anything bigger than the linseed.

Q. If there is any, where does it come from?—A. It must come from the bran, if there is any.

Q. I suppose it may come from the sesamé-cake—you cannot tell that?—A. No, you will not find any, I think, in the sesamé-cake.

Q. You say it may come from the bran. Who has charge of the bran?—A. Well, I have in the daytime.

Q. Who has at night?—A. Well, generally the men that use it put a bit of a night, if they want any.

Q. Now, I do not understand what you said just now, that there were different spouts, one for the seed for the "Triangle Best," and the other the plain "Triangle"—I do not understand that—will you explain that to me?—A. Yes; supposing there is a large parcel of seed at one end of the chamber, and then a large parcel at the other end, there is a spout for *that* to come down to the bin, and a spout for *that* to come down into the bin (explaining).

Q. Then do you store all the seed for the "Triangle Best" on one side, and the seed for the "Triangle Ordinary" on another side?—A. Yes.

Q. You select the seeds?—A. Yes.

Q. Then there is a different sort of linseed goes into the "Best" from what goes into the "Pure"?—A. The same linseed makes the "Pure" as makes the "Triangle Best," only we put a proportion of these small seeds in according to the linseed is in quality.

Mr. Justice BLACKBURN: Just let me understand you; say that again. You say that the same linseed makes them both?—A. The same linseed makes the "Triangle Best" as makes the "Pure."

Q. "Only"—you said something else?—A. Among the "Triangle" we put these small seeds into the plain "Triangle."

Mr. Justice BLACKBURN: You say the same linseed makes the "Triangle Best" and the "Pure"?—*A.* Yes.

Mr. FIELD: Is the linseed that is used for the pure in no way different from the best?—Yes; the linseed that makes the pure cake is screened through the small screen to take out the sand and the small seeds.

Q. And is that which is made into "Triangle Best" not screened?—*A.* Yes.

Q. Which way is it: if you have got a quantity of fine linseed that comes in, do you screen it all, or is part of it screened and part not?—*A.* What makes the pure cake is screened, and what makes the "Triangle Best" is not screened.

Q. Now, in what part of the chamber upstairs is the pure seed kept?—*A.* Well, it differs; sometimes at one end of the chamber and sometimes at another.

Q. There is no specific place for putting it?—*A.* Just in proportion as we have room.

Q. There is no specific place in the chamber for putting the screened or the unscreened linseed?—*A.* No.

Q. And sometimes the screened may be where the unscreened is, and sometimes the unscreened where the screened is?—*A.* Yes; but you will understand me that it is all screened as it comes into the bin to be used.

Q. All! what do you mean—both sorts?—*A.* No, but that that is screened.

Mr. Justice BLACKBURN: Is the linseed that is used to make the "linseed pure" screened and put up in the warehouse in this pure screened state, or do you only screen it from time to time as you are sending it down?—*A.* We only screen it from time to time as the mill uses it.

Mr. FIELD: Now I want to know about the different spouts: you say there is a different spout for the "Triangle Best," and another for the plain "Triangle"—I do not understand that?—*A.* Well, we have a quantity of spouts in the mill.

Q. Is one of them devoted to "Triangle Best" and the other to plain "Triangle"?—*A.* It is, if the seed lies that way.

Q. Then, if I understand, it is only screened as it is used?—*A.* No.

Q. Then what happens at night-time—when it is used at night-time?—*A.* I receive my orders from the foreman what cake they are going to make during the night, and then prepare the seed accordingly.

*Re-examined by Mr. SEYMOUR.*

Q. The pure linseed that you speak of, how many screenings does it undergo?—*A.* Three.

Q. The Triangle Best; how many does that undergo?—*A.* Two.

Q. And are the screens in the spouts by which both the "Pure" and the "Triangle Best" go down to the mill?—*A.* Yes.

Mr. Justice BLACKBURN: I did not so understand it, and I do not yet understand how that could well be.

Mr. SEYMOUR: Just explain it; there is a spout of a funnel shape?—*A.* Yes.

Q. And where is the screen put?—*A.* In the centre of the spout—a circular screen.

Q. So that when you pour the linseed in it is screened?—*A.* Yes; and there is a man stands with a brush brushing these small seeds out.

Q. You say that with the ordinary, or plain "Triangle," you mix the siftings?—*A.* Yes.

Q. Now I ask you this, Can any of the siftings be mixed with the "Triangle Best" without your knowledge?—*A.* No.



Q. There is some suggestion made that a person might open the box low?—A. Oh no, he cannot.

Q. But if he did?—A. If he did he could not get them in; the seed bins are so fixed that no one can get anything in, or anything out, only by going through the rollers.

Q. Therefore, if he chose to do so, would he have to come up stairs for the purpose of getting it in?—A. Yes; but he could not get it in.

Q. Without your permission?—A. Yes.

Q. Therefore a man might steal it, but he could not use it?—A. He might steal it and take it away.

Q. Did you ever see any portion of the siftings that you keep in the bags being used for the "Triangle Best"?—A. No.

Mr. Justice BLACKBURN: Just explain to me what I do not thoroughly understand: when you are going to put in siftings in making plain "Triangle" who takes them for the purpose of putting them in?—A. I do.

Q. Yourself?—A. Yes.

Q. You carry them, if I understood the thing rightly, to the elevators, which are going to put the thing into the hoppers?—A. Yes, down stairs.

Q. Now what I wanted to understand is this, is the seed never raised by these elevators into the hoppers except in your presence?—A. No, there is no one else has charge of them but me.

Q. At night, when you are away, is it ever raised into the hoppers?—A. No.

DENNIS COGGIN, sworn: examined by Mr. CAVE.

Q. Are you sesamé grinder in Mr. Kidd's mill?—A. I am.

Q. And how long have you been with him?—A. Ten years.

Q. Now is the sesamé-cake ground in Thompson and Stather's machine?—A. It is.

Q. And is that under your charge?—A. It is.

Q. Is that in the same part of the mill as the linseed—the grinding machine?—A. No, it stands by itself, it stands in a compartment by itself, and it has an engine to drive it itself.

Q. Have you a man with you?—A. Yes.

Q. A man of the name of Oates who assists you?—A. Oates.

Q. Is this machine of Thompson and Stather's used only for grinding sesamé-cake and nut-cake?—A. That is all.

Q. Is the sesamé-cake used for the Triangle Best?—A. Yes.

Q. And nut-cake for the Triangle Plain?—A. Yes.

Q. What notice do you get when you are going to change from grinding nut-cake to grinding sesamé-cake?—A. Our foreman will tell me at 3 or half-past 3 in the afternoon, he will say the mill is to go on with either Triangle Best or Triangle Plain, and then I change the machine according to what he tells me.

Q. When you get notice that you are going to change from Triangle Plain to Triangle Best what do you do with the machine?—A. I clean all up in the hole where the machine blows it; I sweep up, and then they mix that with the ground. It goes among it; we take and sweep that up, and it goes among the nut-cake that we have ground.

Q. And do you make the machine quite clean?—A. Yes.

Q. After that, when the machine is clean, do you go and get the sesamé cakes?—A. Yes I do. I stop the machine then and go and get sesamé-cake; and I have charge of the horizontal engine that drives it as well.

Q. And when you leave the machine you stop the machine, do you?—A. Yes.

Q. And then you get the cakes?—A. Yes.

Q. And are those brought into the building where the machine is?—A. Yes.

Q. And put ready for use?—A. Yes.

Q. Then do you put them into the machine and grind them?—A. Yes, feed the machine. I have a man to put them on the table to me.

Q. When the sesamé-cake is ground, what becomes of the meal?—A. It blown through, by a blast, into some elevators, and they take it up. It blown through into the elevators by the blast from the machine, and then goes up into a screen—a revolving screen—and then I have a boy at the spout where all the meal comes down. He takes it from there and he whees it into a corner of the warehouse on one side, and then it is left there, and have no more control over that. I have nothing more to do with it.

Q. What is separated from the mill by the screen?—A. There is what comes down—returns. The machine does not grind it fine, and that is the reason we have to have this revolving screen, and then all the returns goes back in the machine and she grinds that up fine and all.

Q. Can any one interfere with this without your knowledge?—A. No, have the charge of the engine, and no one durst touch it.

*Cross-examined by Mr. FIELD.*

Q. Where is the sesamé-cake put when it is first brought into the mill?—A. It is put on a table alongside of me.

Q. When it comes from the ship is it brought by boats?—A. It is.

Q. Where does it go first?—A. It goes into the warehouse.

Q. Who has charge of the warehouse?—A. It is locked up every night.

Q. Who has charge of it?—A. I have charge of it in the daytime.

Q. Then who breaks it up?—A. I break it up. I feed the machine the breaks it up, rather.

Q. How long do you break it up before you use it?—A. It may be twelve hours, or happen not that.

Q. Then, when it is broken up, where does it go?—A. It goes into the mill.

Q. And where is the bran added to it?—A. I do not know—I have nothing to do with that, any further than I have told you.

Q. Then you only attend to this machine?—A. To this patent machine.

Q. All that you do is to break up the sesamé-cake?—A. Yes.

Q. And that passes through a machine which grinds it up?—A. Yes.

Q. Who takes it from you?—A. A boy takes it to the mill.

Q. What happens to it in the mill you do not know?—A. I have nothing to do with that.

*Re-examined by Mr. SEYMOUR.*

Q. Mr. Stevenson and Mr. Kidd give directions there?—A. Yes.

Q. Have you got a specimen of sesamé-cake with you?—A. Yes.—(specimen of the sesamé-cake, *ex 'Result,'* was produced.)

[Two letters, dated 23rd and 24th March, 1872, from the SECRETARY of the Society to Mr. WELLS were here put in and read by the ASSOCIATE.]

Mr. SEYMOUR: That is my case my Lord.

Mr. FIELD: Before I address the Jury, there was a question which I have omitted to put. Mr. Ayre stated yesterday afternoon a conversation with Mr. Wells. There was a conversation, no doubt, the terms of which he alleged a particular way on the 12th February last, and my own impression was that Mr. Wells had already denied that conversation.

Mr. Justice BLACKBURN: Mr. Wells did in the course of one part of!

vidence—it came in a little irregularly. There was something said about a conversation or a letter the day before yesterday, in consequence of which Mr. Wells was interposed; and I do not know where I can find my note of it; but my recollection is, that he very distinctly denied the conversation.

After some further discussion,

Mr. WELLS was re-called, and examined by Mr. MELLOR.

Q. Had you a conversation with the two Messrs. Ayre on the 12th February?—A. I had.

Q. At that conversation, did either of them tell you that the cake contained *esamé*?—A. Neither of them. I never knew there was such a thing as *esamé*-cake till the answers to the interrogatories were put in to show what that cake was made of.

Q. Did you say to them that you had tried the cake for mucilage?—A. I told them that I had tasted a piece of the sample that was originally sent in the letter, and that it appeared a good cake.

Q. Did you tell them that you had melted the cake?—A. By no means, because I never did.

Q. I think, before this conversation, you had paid them a sum on account?

—A. I paid them 107*l.* 10*s.* three or four days before—at least, I had the receipt three or four days before.

Q. And at this time I think you paid them the balance?—A. I paid them the balance, 52*l.* odd.

Cross-examined by Mr. SEYMOUR.

Q. How long were you at Messrs. Ayre's, Mr. Wells?—A. I cannot say—perhaps half an hour.

Q. And I suppose while you were there you were talking about cake?—A. Yes.

Q. You cannot have told us all that passed?—A. I will answer any question you put to me.

Q. I would rather you answered in your own way. Can you recall anything further that was a topic of your conversation?—A. I will answer any question you put to me.

Q. Do you mean to say you did not know it was a mixed cake?—I am quite certain I did not know it was a mixed cake.

Q. You had bought pure cake before?—A. Yes.

Q. And had bought it with a warranty?—A. I have the invoices. I will put out all the transactions I had with Messrs. Ayre in. There (producing some documents) is every transaction I have had with them for the last four years, in which you will find that the whole of my transactions with them have been for pure cake, except one.

Q. And what was the one?—A. One in 1868: 2 tons sent to the Sancton Farm, and 5 tons to Booth Ferry. It was called "P linseed-cake."

Q. Repeat the particulars of that?—A. In 1868 I find I had 7 tons of them which are only marked "two tons P. linseed-cake," sent to the Sancton Farm, and 5 tons sent to Booth Ferry.

Q. What was the price of that cake?—A. 8*l.* 15*s.*

Q. What was the quality?—A. "P."

Q. Put in the invoices?—(Handing them in)—A. The remaining lots for four years are all marked "pure."

Mr. Justice BLACKBURN: Put in the one that is not pure, if it is here?—A. Yes, it is here.

Q. Is the word "pure" on the invoice of the others?—A. All the others

are marked "Pure Lin.-cakes." Some of them are marked "K Pure Lin cakes," and "P Linseed-cakes."

Mr. Justice BLACKBURN: Hand in the one invoice which you say was no "pure," and then we will see what is the difference?—A. There were two.

Mr. SEYMOUR: Two not pure?—A. Two not pure.

Mr. Justice BLACKBURN: Let me look at them; the Jury shall look at them afterwards (the invoices were handed to the Court). These are not called pure or anything else. They are "Diamond P" Linseed-cakes—that is the only description, whatever brand that may be. There are two of them which seem to be the same, except that they are sent to two different farms. Mr. Field had better see them before they are handed to the Jury: he may have some remark to make, or some question to ask upon them.

Mr. SEYMOUR: What sort of cake was that "Diamond P"?—A. A good cake. It did very well for my animals. I know nothing more about it than that.

Q. It was good cake?—A. Yes. That is in 1868; they vary according to the year.

Q. You knew that "Diamond P cake" was not a pure cake.—A. Well, I suppose it was not pure by their not putting pure on it. I should say it was not a pure cake, not what is called pure. It is genuine cake, I should say.

Q. Quite so, but not pure?—A. Not pure.

Q. Now, I think you know the distinction between "ordinary," "genuine," and "pure" cake?—A. Well, I never buy anything under the head of ordinary.

Q. No, but have you not been aware there were cakes known in the market as ordinary, as genuine, and as pure?—A. I should think so.

Q. Differing in prices?—A. Differing in prices.

Q. And were not you aware that the pure cake was described pure because it was warranted as containing linseed only?—A. Yes, that is so.

Q. And genuine linseed is linseed without being sifted as the pure is?—A. Exactly so.

Q. And the ordinary is more or less mixed?—A. The ordinary I know nothing about. I have, however, bought what I call linseed-cake which I considered to be not screened. But that which was screened was pure.

Q. But you knew that the ordinary cake was a cake which was neither genuine nor pure?—A. I have never bought the cake.

Q. But you knew there was such a cake?—A. I have seen it advertised in the circulars.

Q. But did not you know it was a mixed cake, and neither genuine nor pure?—A. I did not know what the component parts of it were.

Q. But you knew that it was supposed to have component parts—you are a gentleman of some experience in these matters, and residing in the East Riding. I ask you this question,—Did you not know that, as distinguished from genuine and pure cake, ordinary cake was composed of certain component parts?—A. I knew there was such a cake; I never knew what the cake was made of, and I should not buy it.

Q. But the distinction from genuine and pure you knew—do you mean to tell me you did not know it was a mixed cake?—A. I cannot tell what it would be.

Q. What should you think?—A. I should think it was an adulterated cake, or one with bad seeds in it—an inferior cake.

Q. I will take your expression, an adulterated cake?—A. An adulterated or an inferior cake.

Q. You were in the habit of receiving circulars?—A. Yes.

Q. And you read the circulars that you received from Mr. Ayre?—A. In which case?

Q. You read the trade circular that has been put in?—A. I do not know that I did. I have said before that I would not swear that even I got that circular; but very likely, if they say they sent it, they would do so.

Q. You knew there was a distinction drawn on the paper between "Triangle Best"?—

Mr. FIELD: The paper will speak for itself.

Mr. Justice BLACKBURN: Give one of them to Mr. Wells.

Mr. SEYMOUR: Have you not been in the habit of receiving that circular (handing a circular to the Witness)?—A. Yes, they sent me one every week.

Q. There you have pure cake, 11*l.* 5*s.*; genuine cake at, I forget what price; and you have "Ordinary cake," and above it "Δ Best" at 10*l.*?—A. Those are not the exact figures.

Mr. FIELD: It speaks for itself.

Mr. Justice BLACKBURN: Undoubtedly, but Mr. Seymour is putting it to the witness to point some question upon it. He is not quite accurate in the figures, but there is the document, and the Jury have a copy of it before them I dare say.

A JUROR: We have, my Lord.

Mr. SEYMOUR: I ask you, seeing that "Δ Best" did you not know by that circular that "Δ Best Linseed-cake" was a cake of an inferior price to the genuine and to the pure?—A. No, not to the genuine, because at the time I bought it it was a little above it.

Q. Did you not know that it was neither genuine nor pure?—A. No, I expected it was a genuine cake.

Q. Although it is distinguished there in a different column?

Mr. Justice BLACKBURN: That the Jury will judge of for themselves. I should say it was not.

Mr. SEYMOUR: I should say it was.

Mr. Justice BLACKBURN: I should consider the circular quite differently. However, at present, you are asking Mr. Wells the question.

Mr. SEYMOUR: Quite so, I am asking Mr. Wells on this circular.

Mr. Justice BLACKBURN: I do not know which circular you have got.

The WITNESS: This is April 19th.

Mr. SEYMOUR: I mean the one you gave the order from?—A. I did not give my order from a circular: my order was given from a letter that was sent to me.

Q. At that time what was the price of the "Triangle Best" as compared with the pure?—A. I should think about 25*s.* difference according to the Hull makers, more according to the Driffield makers.

Q. Did not it occur to you that if it was sold at 25*s.* cheaper it was probably a mixed cake and not a pure cake?—A. No, because I have always said, and I have told Messrs. Ayre, that sometimes I have paid too much for the word "pure."

Q. Was there no allusion made to the word chaff when you were talking to Messrs. Ayre?—A. No.

Q. Bran I mean?—A. Yes, I heard something about bran.

Q. What did you hear about bran?—A. That bran was sometimes put into cakes, and my reply was that bran at 10*l.* per ton was robbery upon the farmer.

Q. But were you told at the time that bran was sometimes put in cakes?—A. We had a conversation about cakes, and bran was mentioned as being sometimes put into cakes, and my answer was—"Well, if it is bran, I should not like to pay for it at 10*l.* per ton," and that it was a robbery on the farmers.

Q. Did not it occur to you that there might be bran in this cake?—A. No, I did not expect it.

Q. Do you mean to say that bran was not mentioned between you as being an ingredient of that cake?—A. I am quite certain that neither bran nor sesamé-cake was ever mentioned in connection with the cake I purchased.

Q. Did you talk of sesamé at all?—A. Not at all. I never heard of such a thing until the other day, as I tell you; I did not know that such a thing was in existence.

Q. What, not that it was used for cattle on the Continent?—A. No, I never knew there was such a thing; it came upon me by surprise.

Q. What introduced the subject of bran?—A. Something in the course of ordinary conversation about the make of cakes. I had paid and settled the account.

Q. Did you say you had examined the cake?—A. I said I had examined the sample sent to me by letter, tasted it, and thought it was a good cake; it was a small sample which was sent to me, and which I have not been able to recover, upon which I made that purchase.

Q. And you said nothing about bran?—A. I said nothing at all to Messrs. Ayre about bran being in the cake that I had purchased.

Q. Nor was anything said by either of them?—A. Nor by either of them.

Q. Now I think you wrote to Mr. Jenkins on the 26th March?—A. If you will read the letter I will tell you.

Mr. Justice BLACKBURN: Is this in any way bearing upon this question, because we had Mr. Wells long ago examined and cross-examined, and I only recalled him upon this one point of the conversation.

Mr. SEYMOUR: Had you any discussion about cotton-cake at any time with Mr. Ayre?—A. I do not know that I had.

Q. Did they never explain to you their reasons for introducing this "Triangle Best"?—A. Most certainly not. I never heard of such a thing; no reason was ever given to me about the introduction of the cake.

Q. And you never asked?—A. I never asked. I thought it was a good cake when I received their sample and a special letter with it.

*Re-examined by Mr. FIELD.*

Q. You say you knew of the "ordinary," the "genuine," and the "pure"?—A. Yes.

Q. And you had always dealt yourself in "genuine" and "pure" except in that one transaction.

Mr. Justice BLACKBURN: No, he had always dealt in "pure" except that one transaction. I mean to say that all his invoices from Messrs. Ayre marked the cakes "pure" except that one which does not mark it as "pure."

The WITNESS: That is so. From 1868 to 1871 they are all marked as pure cakes.

Mr. FIELD: Except that one in 1868?—A. Yes.

Q. And that you say was 7 tons?—A. Yes, at 8*l.* 15*s.* per ton.

Q. When you received this circular about the "Triangle Best" linseed-cakes, "As we are now able to deliver cakes with the above brand," had you the smallest notion that that was other than a genuine cake?—A. I tell you that may have come to me, but I do not admit having received it. I do not remember it. If I received a thing like that I should throw it into the waste paper basket as being a puff.

Q. But had you any notion that it was other than a genuine cake?—A. I had no notion that the cake that was offered me was other than a genuine cake. In fact I would not have bought it at all if I had.

Mr. Justice BLACKBURN: Now, unless the gentlemen of the Jury wish to

ask Mr. Wells any question, which I suppose they do not, Mr. Field can go on with his address.

Mr. FIELD: May it please your Lordship, and Gentlemen of the Jury, I am very glad that the time has come for me to address you in this case. It is a case the importance of which cannot be exaggerated, for it affects the interests of a very large number of persons. It affects Mr. Kidd, of course, and my learned friend is fairly entitled to put before you the grounds upon which he has brought this action. It affects the Defendants; it affects still more largely the large number of persons whose interests on this occasion they are rightly or wrongly endeavouring to protect—the principle involved being one of the greatest possible consequence.

Now, Gentlemen, first of all let us see who is the Plaintiff, and let us see who are the Defendants. The Plaintiff, Mr. Kidd, is a seed-crusher at Hull, which, you know, is the centre of a staple trade in cakes. It has been established, I do not know for what length of time, and we hear from Mr. Kidd that he is one of the largest makers in that town. Now, I must beg your attention on this occasion to distinguish between Mr. Ayre and Mr. Kidd, because although of necessity many matters connected with Mr. Ayre have been brought into question here, until I hear from my learned friend that another action that has been set down in this list is to be disposed of by this cause, I must beg you not to take into consideration in this case those matters affecting Messrs. Ayre, inasmuch as you, or some of you, may have to dispose of them in another action. The next cause in order in the list is one at the suit of Messrs. Ayre against the Royal Agricultural Society, and it will have to be tried upon its own merits, if it is to be tried at all. The action by Mr. Kidd will, of course, have to be tried upon its merits also; and although I am perfectly willing that we should go, as of necessity we must go, to a considerable extent, into the questions that have arisen with regard to Mr. Wells and Mr. Ayre, I ask you to recollect that on this occasion I have the honour to represent the Council of the Royal Agricultural Society. They are the Defendants here: it is against them that this action is brought by Mr. Kidd, and it is with respect to the matters, if such matters there are, that are injurious or wrong as regards Mr. Kidd, that you are asked to give your verdict on this occasion. Therefore, Gentlemen, I beg your attention (I am sure I shall have it) when you come to consider the questions which my Lord will leave to you, to what it is that Mr. Kidd complains of, what it is that he has a right to complain of, and then you will see in what respect his complaint is well founded, or how far the Society is well founded in their answer to it.

Gentlemen, the Society, as I dare say you are aware, is a voluntary Society acting by means of their Council, established to provide for a perfectly legitimate object, that object being, in point of fact, for the consideration of, and judgment upon and regulation of, matters connected with the Agriculture of England. Its members come from all parts of the country. I need not talk to you, of course, about the enormous interests which the agriculture of this country represents, because whether the Society be voluntarily constituted for the protection of their own interests and rights, or for the protection of the rights and interests of the farmers and landowners whose interests they represent, I do not, of course, say that that gives them any exceptional position at all: they have still to answer for their acts as fully and fairly as anybody else. Still it bears very strongly on the question which is ordinarily discussed in cases of this sort as to what their motives have been, and as to what their objects are, and the causes and reasons which have induced them to enter into this controversy.

My learned friend in opening the case said that in the beginning—which I am satisfied nothing has passed since that would induce him to recall—

namely, that he on his part makes no complaint against the Society that they have been actuated by malice or any indirect motive in what they have done. And, indeed, had he said the contrary, I think, upon the evidence before you, you would see that in doing what they have done, and publishing the report which they have published, they have been acting without any personal reference to Mr. Kidd or Mr. Ayre; and solely on the ground for which they are constituted, and which they have endeavoured to carry out, namely, on the ground of the public interest of those who have to buy cakes and manures and other matters connected with agriculture, to protect them against what in the judgment of the Society is an adulteration of an article so extensively used as this.

In this particular case they have adopted the course which they ordinarily adopt. They appoint a Chemical Committee to examine the various cases that are brought in. They have their officer, Dr. Voelcker, whom you have seen before you, who is their consulting chemist, and when any person connected either with agriculture or manufacture seeks his opinion, it is part of his duty to the Society to give it to those who are members; and besides that, he gives it to other persons who ask for it with reference to the analysis or composition of the various things which may be submitted to him. He has before him the samples of the manures and the cakes, and on this particular occasion (you will have to deal by and by with what happened at Mr. Wells's farm more in detail) the Society was called upon by Mr. Wells, and their officer, Dr. Voelcker, was called upon to do that which it was part of the object of the Institution that he should do, namely, to examine and analyse and report upon the cake which is the subject of the present inquiry.

Gentlemen, you have before you that which the Council of the Society had before them—the report of the analysis and microscopical or optical examination of Dr. Voelcker; and upon that, the Council, having no reason to doubt its accuracy, as I venture to think after the trial of this cause you will have no reason to doubt it, in pursuance of their ordinary course, without any reference whatever particularly to Mr. Wells or to Mr. Kidd, or any motive at all with reference to them, published the report in question of which complaint is now made. It was published by them in a paper devoted to agriculture, the ‘Mark Lane Express’—and for the purpose, of course, of drawing the attention of the agriculturists, whose interests they represent, to what had occurred in reference to the cake and manure of which the history is given.

Now, before I come to the details of this particular case, let us first of all read what it is that the Society say of Mr. Kidd, and then I will go through, as shortly as I can, the proofs that the Society have given in support of their allegations. I venture to think—I may deceive myself; of course an advocate is always liable to that—but I cannot help thinking that when I have drawn your attention in detail to the evidence before you, I shall satisfy your minds that the truth of this libel, as it is called, and as in point of law I do not doubt it is, has been substantially in effect proved to your satisfaction. Now, let us see what it is that they say, distinguishing carefully, as I said, between what is said of Mr. Ayre and what is said of Mr. Kidd, for the reasons I have told you. It is “The Quarterly Report of the Chemical Committee”—I am sorry to read it to you again, the trial has taken so long, but I should not do my duty if I did not draw your attention to it. “During the last quarter very few samples of artificial manure have been forwarded for analysis. Of those sent to the Consulting Chemist he has no complaint to make. As usual during this season cases of so-called poisoning from the use of cakes have been brought under his notice.” Now, Gentlemen, the Plaintiff's advisers in this action have thought it right to put upon their declaration what we call an inuendo, by which they assert that this meant an allegation



that there was poison in the cake, and that the beasts had been poisoned by the administration of that poison. I deny entirely that that is the fair meaning of this article when you come to read this part of it as well as the other. That which is here called "so-called poisoning," is a very different assertion indeed from absolute poisoning; it is, in truth, almost drawing attention to that difference and distinction. In fact, they carefully abstain from affirming that the illness arose from the administration of a poisonous cake. I venture to think that you will be of opinion that that is the meaning of it; and that meaning is made more clear when you come to see what the other allegations of the Report are, and what are the facts respecting the cake in question.

The first case mentioned is one from a stranger to the Society, Mr. Eaton, of Toleshorpe Hall, Stamford, which is a case with which I need not trouble you now. Various things were found, and the Veterinary Surgeon who made the *post mortem* examination could make no other discovery, and gave it as his opinion that the animal had been poisoned by cake. But nothing of the kind is said when you come to the report on Mr. Kidd's cake, which is now in question before us. After publishing Mr. Eaton's letter in reference to that cake, which in no way refers to the cake in question, it goes on to say "The cake contained much earth-nut, also locust-meal, rice-dust, grass-seed, broken corn, and the usual small weed-seeds found in an inferior or dirty linseed, and was altogether a bad linseed-cake." Therefore, you see you have, even with regard to Mr. Eaton's case, the elements given of which the cake was composed, and you have no statement beyond that. Then having disposed first of all of that particular case, the Report proceeds to deal with the cake now in question, and begins by saying "Another case comes from John Wells, Esq, February 18th, a member of our Council, the whole of whose cattle were attacked with serious symptoms immediately after eating from a fresh purchase of cake, although only one case terminated fatally. The cake very much resembled the cake sold to Mr. Eaton, containing a quantity of seeds, cotton-cake, rice, broken corn, and cocoa-nut, apparently made from dirty linseed and the sweepings of corn warehouses." You will not forget those words "apparently made." "A small sample of this cake had been sent before purchase to Mr. Wells as best linseed-cake, price 10*l.* per ton, from Ayre, Brothers, Hull—the makers, Messrs. Kidd, of Hull." Therefore, you will observe that the allegation there, so far as regards Messrs. Kidd, is that they are the makers of the cake which Mr. Ayre sold—a matter which of course is now beyond all doubt and question—that the cake itself very much resembled Mr. Eaton's cake, which contained a quantity of seeds, cotton-cake, rice, broken corn, and cocoa-nut, apparently made from dirty linseed. With regard, of course, to the dealings between Mr. Wells and Mr. Ayre, you will have to consider whether or not that part of the statement is not well made out if in any way it can be considered to involve any charge against Mr. Kidd. All we know about Mr. Kidd in reference to this matter is this: he says, and Mr. Ayre says, that before he made it he told him the exact composition of it. They therefore by an agreement about four years ago seem to have determined to manufacture this cake, and it will be one of the questions for your consideration what that agreement was, what it amounted to, and when you come to consider whether what is stated here is not perfectly true, that Mr. Wells bought it from Mr. Ayre as best linseed-cake, you will have to deal with Mr. Wells's and Mr. Ayre's evidence, and I shall deal with it also before I have done addressing you.

Now, Gentlemen, you see therefore the positions of the Plaintiff and the Defendants. The Defendants have no interest whatever of their own to serve. I do not suppose or contend that that absolves them from the consequences of their acts. Far from it. I am here fairly to meet the consequences. I should be ashamed of myself and of the Society that I have the honour to represent,

if I did not do so; but at the same time if any motive is to be imputed, I have a right to put the Defendants before you in their true position as to what they have done on this occasion. Because my learned friend has insinuated indirectly something as to their officers, and he referred to letters which he intends to refer to again, I dare say, it therefore becomes my duty to place the exact and true position of the parties before you, in order that you may come to a fair and just conclusion on the merits of the issue which is raised between them.

Now the state of things with regard to that is this: the libel having been published in the 'Mark Lane Express' in the way I have told you, a correspondence takes place between Mr. Kidd and his lawyers, and the Defendants and their lawyers, and actions are brought, one against the 'Mark Lane Express,' one against the Agricultural Society, one against a newspaper in this county, which stands lower down in the list, one by Mr. Ayre against the present Defendants, and one by Mr. Wells against Mr. Ayre. All this has branched out into an enormous mass of litigation, which will have to be cleared away in some shape or other when we shall know the result of your verdict in this cause.

Now let us see what occurs after that. The Society having been written to by Messrs. Roberts and Leak, who are the attorneys of the Plaintiff, at once accepted the responsibility, which I on their part now accept, of having been the authors of the article in question. But I am not going to trouble you now by going through the correspondence which passed between the professional men on both sides, because, although I know my friend is going to make a grievance of one or two points connected with that, I cannot help thinking that the issue you will have to try will be very far removed from those skirmishes and struggles on the one side and on the other, which take place between the attorneys before the trial. I am perfectly prepared to meet my friend on any observation he may make on the matter if the necessity should arise, but I will now simply deal with the two points he has made. I know if he were going to make any others he would have given me notice, because he knows I cannot speak again. Therefore I assume those will be the points he will address himself to. Now these points are matters of prejudice in two ways; first of all, that the Society did not communicate with Mr. Kidd before they wrote the letter in question. Gentlemen, the very object of the Society, be it a good one or a bad one, is that if they come to the conclusion, as they honestly did, that the cake in question was such as they have described it, and as I hope you will believe it was their duty to describe it, looking to the interests vested in them, to see that the names of the purchasers and the makers of the cake should be given. Their functions would be of no value comparatively at all, unless that was done; and as for calling upon Mr. Kidd to answer, or anything of that kind, they, having no jurisdiction, would be treated in the mode in which they were by the attorney's letter. Therefore, it was entirely out of the question in every respect. Another complaint has been made, which is, that during the course of the negotiation between the attorneys, we did not forward them a sample—a complaint which, now you have heard the case tried, I venture to say you will consider of the most unsubstantial character that can possibly be conceived. For, would you believe that my friend, who complains in his opening address to you that he has had no sample of the cake, has actually had in his possession eight tons of, as he says, the very same article; has been giving it to cattle by way of experiments for food, and has actually himself (I mean Mr. Kidd, his client), indirectly, under the guise of putting Mr. Knowles forward, obtained from Dr. Voelcker, unknown to that gentleman, an analysis of the very cake in question?

Mr. SEYMOUR: That is not so.

Mr. FIELD: It is what Mr. Kidd said.

Mr. SEYMOUR: I beg your pardon.

Mr. Justice BLACKBURN: I thought the sample that Mr. Knowles sent was of a different cake.

Mr. SEYMOUR: Totally.

Mr. Justice BLACKBURN: I thought the sample sent by Mr. Knowles was this: that Mr. Kidd gave Knowles a sample, which Knowles sent to Dr. Voelcker, and got an analysis of it. My impression is that that sample was "Diamond K."

Mr. SEYMOUR: It was 80 per cent. of linseed and 20 per cent. of sesamé.

Mr. Justice BLACKBURN: A separate cake altogether.

Mr. FIELD: Then it was my mistake; I understood it was a portion of the cake in question. At all events, Gentlemen, let that be as it may, the observation still remains, that the Plaintiff has had actually 8 tons in his possession, and has given it away to different people to try experiments with their cows. Therefore, what becomes of the complaint and the grievance that is made by my learned friend? Besides that, I shall not weary you by reading letters, but I shall show you that on two occasions the Plaintiff's advisers made the fairest offer which could be made under circumstances of this sort, which is, "We will produce the cake to an independent chemist, who shall make an independent analysis of it." There are two letters which I will read to you, because it is desirable, before coming to the facts, to clear away these matters of fringe and prejudice. "We have entered formal appearance to both actions [that is the 'Mark Lane Express' and the Royal Agricultural Society]. The Society is actuated only by motives of public good in publishing the Reports of its Chemical Committee, and holds itself responsible for the publication in the 'Mark Lane Express' of the Report of which your client complains. His action, therefore, against Mr. Alger the publisher of that paper, is clearly unnecessary for any real good to himself, and should, we suggest, be at once discontinued, to prevent useless expense. On this point also we would call your attention to an editorial note in last week's issue of that paper in reference to the publication of the Report in question. In publishing its Report the Society is most desirous to avoid any just ground of complaint, and wishing to act in all fairness towards your client, and to prevent unnecessary litigation, we have now on the Society's behalf to offer him the opportunity of testing the correctness of the analysis made by the Society's Consulting Chemist (Dr. Voelcker) of the cake in question, from further samples of it in the Society's possession, by any other gentleman of equal professional standing, and to publish the result, if desired, in the same way as Dr. Voelcker's analysis, with any further explanations that may be necessary." Now, Gentlemen, I will ask you whether, under any circumstances, there could be a fairer offer than that made as to what was to be done. On matters of science, unfortunately, generally we have chemists and surgeons on the one side and on the other contradicting each other, or differing from each other as to the results of analyses, or as to the effects of any given cause. But here, fortunately, gentlemen, we are spared that, because Dr. Voelcker, Mr. Way, Professor Tuson, and Mr. Fairley have not been contradicted by anybody who has been called upon the other side. The gentlemen who wrote that letter are well aware of the scandal which sometimes, I am sorry to say, exists in courts of justice by reason of the differences of opinion between scientific people, and offered at once to give the Plaintiff an opportunity of testing the correctness of the analysis made by the chemist employed by the Society from samples out of their possession, by any other gentleman of equal professional standing, and to publish the result, if desired, in the same way as Dr. Voelcker's analysis was published, with any other explanation that might be necessary. And, Gentlemen, I do ask you, upon what fair principle could that offer be refused? Of

course Messrs. Roberts and Leak had a perfect right to refuse it if they chose, but I think, having refused that offer, it is hopeless for their learned Counsel to complain that they had not a fair opportunity of testing the thing by submitting it to any gentleman they chose; and remember, gentlemen, had the result turned out differently, here is a direct offer to give any explanation, or adopt any course, that might be fair and honourable between the parties. Gentlemen, do not you think that justified the Society and their advisers in the course they took; but it is not all. Later on, on the 6th July, application having been made for a sample, there comes this letter: "We shall have, as we before said, samples of the cake in court, properly identified, if you now really want us to test Dr. Voelcker's published analysis, or to make an independent analysis of your own, we are willing that Dr. Voelcker shall meet any chemist you may intend to employ, and make a joint analysis for either party to refer to at the trial, if necessary." Again, I say, what could have been fairer than that? Is it not saying, "We have the cake here, appoint whom you please?" It is not a correct inference from that letter that Mr. Roberts, in his subsequent letter, draws that we asked them to be bound by that analysis. Nothing of the sort: it refers simply to the avoidance of the complication which you get into from people having their analyses made under different circumstances, and having to inquire, when you come to the trial, into all the various elements of the examination, when made, and so on. To avoid all that, we say, "Appoint any gentleman you please of your own; let him meet Dr. Voelcker with whatever conditions are necessary in order that the analysis may be ascertained to be fair; let that analysis be made, and do what you please with it for the purposes of the trial." I am sorry to have detained you with that which, after all, does not affect the real question at issue, but which might be made use of, if not properly understood, as a topic of prejudice when my friend comes to address you on behalf of the Plaintiff in this action; but I think it would be unnecessary for me to proceed further upon what I call the preliminary points of the case.

There were some letters put in by my learned friend at the very last moment to-day, and I must presume he put them in with the object of commenting upon them. I am perfectly willing, of course, to stand by what is said in that letter, which you will remember. "I am much obliged by your letter received this morning containing answers to my queries, and enclosing a copy of Mr. Fairley's Report." All this shows that the Council were fairly investigating the matter with Mr. Wells; they were suggesting an inquiry, and doing that which it was their duty to do, and which they say they are about to do. What was their position? Mr. Wells was the person to whose cattle this thing had happened. The facts of the case are entirely within Mr. Wells's knowledge with reference to all that. Mr. Wells was the gentleman who had sent up the animal's viscera to Professor Simonds, and the cake to Dr. Voelcker, for examination; and it was acting upon those facts as stated to the Council, and upon the examinations reported to them, that they published the libel which is now complained of. Surely under those circumstances they had a perfect right to say to Mr. Wells what they say here. "You will observe that if neither Mr. Dean's 5 tons, nor the remaining 8 tons in your warehouse, should prove injurious to stock, it will give great support to Ayres's assertion that it was not the cake, but something else that killed your short-horn cow." I am perfectly well prepared. I do not want my learned friend to remind me of what he here says. I am perfectly willing to deal with both the 5 tons sent to Sancton and the 8 tons we have heard about to-day; and I am quite satisfied that when those matters are properly examined, you will find it gives no support whatever, although it is a matter fairly for you to consider, to Mr. Ayres's observation that it was not cake but something else that killed the cow. Gentlemen, I cannot, of course, anticipate what are the observations that my

friend intends to make upon that, because he carefully confined his opening within the narrowest possible limits. He gave no clue to me at all of what his case was going to be. He declined putting the Plaintiff into the box then, and he has left me to address you to-day without his ever venturing to presign what his charge against the Society is; but covertly, at the last moment, he refers to letters without giving me any idea at all of what observation he intends to found upon them. But I care not for it, because the letters speak for themselves. You are men of business, and you will assess and measure any comments my friend may please to make upon the correspondence in that matter at their right value.

Now, that being so, let us come more closely to the facts of the case, and no doubt the question you will have to consider bears upon the question of the manufacture of the linseed-cake, and indirectly the substantial question is, Do the Society prove what they have asserted of Mr. Kidd in this Report? Now let us see what is the general nature of the case—the admitted grounds if you like—on both sides. Linseed is an article which, taking a great deal from the land, is valuable as giving back to the oxen and to the land those products it has taken from it. It is an article of commerce, the first use of which is the expression of the oil from it, which is used for various commercial purposes; and the expression of that oil in its natural and legitimate course, leaving behind it the solid part of the seed, forms from its farinaceous property, and from a certain quantity of oil which may remain, a residuum which is a valuable feeding substance for animals. And it is well known to everybody, and to Mr. Wells, so far as his knowledge is important in this case, that there are two classes of cakes, the use of which, and the dealing with which is perfectly legitimate. The linseed growing abroad, there grows with it a variety of things which are not linseed—seeds, and weeds, and other things of that sort; and assuming the most honest exportation from the Black Sea, St. Petersburg, or India of the commercial product known as linseed, there will still be mixed with it a certain number of these seeds. On arrival in England two courses may be adopted with it. I believe in the first instance the linseed, such as it was after the oil was expressed from it—the residue of it—was formed into cake, but the manufacturers of linseed afterwards undertook a further operation—namely, the screening from the linseed, as it comes into this country, of a considerable quantity of the seeds that are mixed with it, and thus to make a cake out of what was left. That was of course a perfectly legitimate operation, and of course it would be perfectly understood that those who wish to have a linseed-cake upon which that labour and skill had been expended, would have to pay a higher price for it. Therefore between what may be called “genuine” cake and what is called “pure” cake, there is a well-known distinction, understood by everybody, and perfectly legitimate, and there is no false assertion or misrepresentation with reference to the one or the other. The one is called by its proper name “genuine,” it being a genuine thing, inasmuch as it is the very thing which comes from the Black Sea and St. Petersburg or Calcutta into this country; the other called “pure,” inasmuch in this country it has undergone the process of taking away these small seeds which are injurious in themselves, or do not yield a proper quantity of oil or nutritious matter. Therefore you have at once two legitimate things which are fair objects of commerce. Gentlemen, with regard to the merchants and cake-dealers of Hull or elsewhere, who are desirous of selling an article which shall consist, not of that thing, but of bran, or sesamé, or nut-cake, or earth-nut, or anything of the kind, do not understand me for a moment as doubting or disputing their perfect right to do so. They have as much right to sell anything of that kind, as anyone has to sell any other article of manufacture, provided only they will tell the people with whom they are dealing what it is they are selling,

and what it is their customers are buying. With that limit everybody has a right to sell what he pleases, but the practice which the Society in this case, through me and through its officers, condemn, is the practice of selling things which are not that which they represent themselves to be, under a name calculated to deceive even the most intelligent, and certainly calculated to deceive farmers and agriculturists and others, whose interests are involved in the use of this cake. Therefore do not suppose that we should be complaining for one moment if this case had been a fair and open assertion on the part of the crusher and breaker that they were selling a cake, 50 per cent. of which was an article different to linseed, or another cake in which we hear that only 30 per cent. of linseed was left in it. Do not imagine that, or that the Society would dream of finding any fault with that practice, because everybody would be then on equal terms; and if a man gives a smaller price for an article, knowing perfectly well from the description given to him, and told to him, that it is not the article which it is described to be, of course he has only himself to blame, if for any reason his purchase is unsatisfactory. But that is not the question here. My learned friend's contention is that sesamé and bran are harmless things, and in a certain event of course, if you have pure sesamé and nothing but bran, that may or may not be the case; but here the complaint is of the introduction or admixture. It is not for me to say what the purpose of the introduction may be—I am not in any way bound to assert that or to prove it, because, recollect, the libel simply describes the cake as containing these admixtures; the question for you to consider will be whether or not the fact is not substantially made out—the next question being, whether or not it was bought from Mr. Ayre as linseed-cake, the maker being Mr. Kidd, both of which assertions I hope to satisfy you have been well and effectually proved.

Now that being the first character of the thing, let us see what it is that the Society complain of in this particular cake. First of all we will take Dr. Voelcker's Report—and let me remind you, that although Dr. Voelcker was called here as a witness, now, I think two days ago, we have not had anybody called on the part of my learned friend to contradict him—not a single scientific man to contradict him. We have had Mr. Kidd of course, and the persons employed in his mill, but although the Plaintiffs have had eight tons of this cake in their possession, as they say, we have had no one to deny the accuracy of the evidence given by Dr. Voelcker, Professor Way, Mr. Tuson, and Mr. Fairley, as to the actual things which they found in this cake.

Now what is the assertion made and proved here on the oaths of these gentlemen as to what they did find in the cake? And remember that there has been plenty of opportunity, long opportunity of course, it being well known that this was going to be gone into, for contradicting their evidence by having an analysis of the cake, or an examination of the cake made by my learned friend or the scientific gentlemen who assist him in this matter. Dr. Voelcker made his analysis on the 2nd of March, the moment after the thing happened almost, and there is no concealment or doubt about it. On the 17th of February Mr. Wells complained at once to Mr. Ayre by telegraph, and there was never any hesitation on his part in asserting from the beginning to the end of this controversy that this particular cake was the cause of the mischief that happened to his cattle. On the 2nd of March Dr. Voelcker, there being no matter whatever in litigation at this time, but acting merely as the analyst of the Society for the purpose of finding out what the cake contained, makes the examination which forms the foundation of the Report published in the 'Mark Lane Express,' and I now beg to call attention to that Report. After speaking of the chemical analysis, which he truly says enabled him to arrive at no conclusion with reference to the poisonous qualities of the cake (you will see the reason very quickly), he says, "with regard

to the microscopic examination on the other hand, it enables me to say that the cake which you sent me is not a genuine linseed-cake; for, in addition to a number of small weed-seeds—such as the seeds of the *Chenopodium*, *Polygonum aviculare*, wild-mustard, clover-seeds, the seeds of the *Lolium temulentum* (drunken-darnel), grass-seeds, and other small seeds usually found in dirty linseed—I find in the cake cotton-seed husks, cocoa-nut cake, rice-dust, millet-seeds, bran, or broken wheat. It appears to me to be made from dirty linseed, containing the sweepings of granaries or seed-warehouses, and unquestionably is not a genuine linseed-cake. At the same time I am bound to say that I have been unable to detect in the cake any positively poisonous matter. I can, however, readily conceive that a linseed-cake which is made, as most probably the cake you sent me is, from linseed and the sweepings of seed-warehouses, may do serious injury to stock; for it is not at all unlikely that in such sweepings there may be injurious seeds, the injurious properties of which can only be detected by the effects they produce when cake containing these extraneous matters is given to cattle." Now, gentlemen, that was therefore, you see, the distinction that Dr. Voelcker then drew between these seeds which may be found in a genuine cake of which no complaint was made, and the extraneous matters which he expressly indicates by his Report (confirmed by Professor Tuson, Mr. Way, and others) he found in this cake, and which have no reference whatever to the other. That being the state of things, one thing is clear, that the cake in question is not a genuine cake; of course it is not a pure cake, that is not pretended. It is a compound cake, and there are three respects in which it is now conceded that the cake in question is what I venture to call adulterated. First of all Mr. Kidd tells us himself that the "Triangle Ordinary" only has 30 per cent., if I recollect right, of linseed in it; so that you start with this. Mr. Kidd has been in the habit of selling as linseed-cake a cake containing only 30 per cent. of linseed, the remainder being made up of nut-cake to the extent of 50 per cent., and of bran to the extent of the remaining 20. A more remarkable admission made by Mr. Kidd, and one I was sorry to hear him make in the box, was this; he says, further, "In that cake so made I put deliberately the siftings from the genuine linseed which come out before the pure cake is made; I do that whenever, in my judgment, I think that the linseed which I am putting into the 'Ordinary Triangle' is of too good a quality. I then deliberately mix with that the siftings which have come out of the pure seed." Now, Gentlemen, I said before if Mr. Kidd told the public that he did that he would have a right to do it beyond all question; but did he ever tell the public that? It was never heard of for a moment until he gave it himself in cross-examination. None of his circulars in any way show that he did anything of the kind, nor do Mr. Ayre's circulars. It is not suggested until Mr. Kidd tells it me in the box that anything of the kind ever has happened at all, or was disclosed at all to anybody, not even to Mr. Ayre. That is one thing; that is his way of dealing with the "Ordinary Triangle." Now, with regard to the "Triangle Best," we have again the most remarkable thing disclosed, for the first time, in the interrogatories administered in this action, namely, that the "Triangle Best," which upon the circulars is called "Triangle Best Linseed-cake," which in every invoice, receipt, and letter passing between Mr. Ayre and Mr. Wells is called "best linseed-cake," that not only is it not best linseed-cake but that it is not linseed-cake at all, for only 50 per cent. of that is linseed, the remaining 50 being composed of sesamé-cake and bran. Now you know, Gentlemen, there we start at once with the issue between my friend and myself. I deny that that is best linseed-cake, and I say this, if you find parties are dealing in that way and are putting siftings into linseed whenever they think right in their judgment as manufacturers, not telling the public at all what they are doing, but

simply because they choose to say we think the linseed is too good; if they choose to put siftings into that, or if they tell the public they choose to put sesamé and bran, instead of linseed, into cakes, and call them "Triangle Best Linseed-cakes," that is a matter which I say they are not justified in doing; and when they can give no explanation of that, I say it is a matter which you will require them to satisfy you very clearly and satisfactorily upon to prove that they have not done that which they are charged with doing upon this particular occasion.

Now how is that attempted to be got out of? By being told that "Best" is a trade mark. I was astonished! That that which you choose to call "best," that that which you choose to call "linseed," that that which you choose to call "Best Linseed-cake," is all only a trade mark, and is not at all intended to assert that which in plain and simple language it does assert! Gentlemen, it strikes at the very root of every commercial transaction. You first of all receive a circular inviting you to buy an article; you are told that it is best linseed-cake. What difference does the triangle make? None whatever. It is that, indeed, which is the trade mark. Why you know Messrs. Bass and all those persons have their bloody hand, and their triangles, and different trade marks, but is it to be said that therefore Messrs. Bass, instead of putting 100 per cent. of malt and hops into their beer, might put in a proportion of one-half of any other product, and that because they put their trade mark upon the bottle that would be an intimation that they were not selling that which they distinctly stated they were selling. Gentlemen, you know that would be entirely out of the question, and so it is entirely out of the question, as I submit, in this case.

Gentlemen, we are told that this had been going on for four years, and my friend is very strong upon the question of the circulars which have been issued and which he asserts indicate to the public that that thing is what the Plaintiff says it is well known and understood to be—a compound mixed cake and neither "genuine" nor "pure" nor "best." I am astonished, I must confess, when I look at the circular that he ventures to rely upon for that assertion. I hold in my hand a copy—I think you have one of them—which is dated 31st January 1872. They are all in the same form and therefore for the purpose for which I am going to observe upon them, they are all equally good. Now, do just look at the mode in which Mr. Ayre describes the cake. He begins by saying "Issued to the trade only," but he says, he sent them to Mr. Wells, and Mr. Wells says he was in the habit of receiving them, but he never took any notice of this, and certainly those circulars did not form the foundation of this transaction, because to that specific circular of the 19th January I shall call your attention presently. Well now, just look at this circular; in large type (I do not know what sort, for I am not a printer), but so as to draw every one's attention to it, is written " $\Delta$  Best, 10l." Then "A. C. Best, 10l." "A. C. Pure, 11l. 5s." with warranty. Now, I will ask you, is there more described than certainly two classes of cake—"Best," "A. C. Best," and "A. C. Pure," the labour of screening being as I said before, allowed for by the extra price. But there it is in large letters the " $\Delta$  Best" which Mr. Ayre is so desirous, as he tells you, of pushing, but which the gentleman from Durham does not like to push at all—that is the cake which he invites people to buy, and there it is described in exactly the same terms as the best linseed-cake. Well, my friend seems pressed by that, and so he examined Mr. Ayre about it. "Oh," says Mr. Ayre, "he knew from the circular it was not that, because it appears under 'ordinary quality.'" Does it? Nothing of the kind. A line is drawn under these three things, and then you get three columns of other descriptions—"ordinary quality," "genuine quality" and "pure quality;" and Mr. Ayre has the ingenuity (or call it what you will) to say that, because the " $\Delta$  Best, 10l." happens to be over "ordinary quality," there being a line



drawn between them, therefore, that amounts to an assertion to everybody who received that circular, that it was a compound cake. Why, Gentlemen, look at the next "A. C. Best, 10 $\frac{1}{2}$ ," the same price (which you know is made another best) as the "Triangle Best." That is over the "genuine quality." Therefore, I suppose he would say that was a genuine quality, the price being identically the same; and clearly no one who took up that circular would have the smallest notion that the words "ordinary," "genuine" and "pure" governed that which was purposely placed above it instead of under it. Had those words "ordinary" "genuine" and "pure" been in large print and had those other things been underneath, then one might have understood it perfectly well, but I say it is a carefully prepared circular for the very purpose of avoiding that. And then, you know, Gentlemen, Mr. Ayre comes and says "I made this arrangement. I did it because it was a bad thing which the farmers were getting—they were getting cake which was not uniform—and I thought I should like to have an uniform cake and put into that uniform cake bran which the farmer was to buy at 10 $\frac{1}{2}$  per ton, when he might get it from his own miller ground from his own wheat) and sesamé-cake at 10 $\frac{1}{2}$  per ton also; and that was to be the uniform thing which would please the farmer a great deal better, and I always told everybody with whom I came into contact what this thing was. I told all the dealers. I was most anxious. We were doing a bouncing trade. It was a great thing, and I invariably told everybody what it was they were buying." Well, I said to him, "Did you tell it to everybody? Have you anybody here to whom you did tell it?"—"Oh, yes, I have Mr. Hope and Mr. Glover here, and I told a great many other people besides." I asked him, "Whom have you got here?" He said, "We have got Mr. Hope and Mr. Glover, and I told them what it was made of and all about it." Accordingly, he called those two gentlemen this morning; Mr. Hope of Hexham was the first, and Mr. Glover of Warwick was called afterwards. I then said to him, "But besides that, as you told all this to everybody, did you ever put it in writing and send it to anybody at any time in any circular?"—"No, never." Well, but you know, it would have been a comfort, of course, to one's mind—would have eased one's mind, if you could have found Mr. Ayre putting this in print—in black and white, so that there should be no mistake about it—he was doing this bouncing trade, sending out these circulars, published every week, and if he had put this in writing neither the Society nor I who represent them, could have said a word about it. But he says "No, I never put it in writing; but I said it verbally to everybody, and there are two persons here who will vouch for me." Nobody else is called but these two persons, and they are two persons in the trade who have been dealing with Mr. Ayre for the last five or six years, and neither of whom confirmed him as to the account he gave. And, Gentlemen, when you come by and by, as you will have to do, to weigh Mr. Ayre and Mr. H. H. Ayre in the scales against Mr. Wells, I ask you also to take into your consideration this—that Mr. Ayre told me last night he had disclosed the nature and composition of this cake to these two gentlemen; and now let me tell you what these two gentlemen say he did disclose. He says, you know, he told them there was 50 per cent. of these other materials in this cake, but Mr. Hope says, "He introduced to my notice five years ago the best linseed-cake and told me that linseed as imported is often full of dodder and weeds and that by sifting it (all which Mr. Ayre did not say a word about) and adding bran it would make a good wholesome cake and be likely to give more satisfaction than the so-called genuine linseed-cake." It is not pretended that the linseed is sifted for this cake—it is the genuine cake which is not sifted—

Mr. Justice BLACKBURN: You are not quite accurate. The witness who was called this morning—the last witness Logdon—said it was sifted, but not much.

Mr. SEYMOUR: Twice.

Mr. FIELD: Gentlemen, it is a very remarkable thing that that man should have been called this morning, and that we should not have heard a word about that last night from anybody. I asked Mr. Kidd, and my recollection is that I heard it for the first time this morning.

Mr. Justice BLACKBURN: I do not say they did not say so, but I certainly had not noticed it.

Mr. FIELD: My own opinion is that the witness was fetched this morning he was not here yesterday, and my recollection is that until this morning never heard a word about it; but certainly Mr. Ayre, who gave us the account last night very carefully of the mode in which the cake was made, did not rely upon sifting at all; and it was from this gentleman first that we heard any assertion of this sort.

Now the other witness, Mr. Glover, of Warwick, cannot tell us anything at all. He does not confirm Mr. Ayre in any way; he does not know what it was he said, or of what composition he told him the cake was; he only says he understood it was a cake which he was to have in place of the second quality. He says, "I cannot say what it was, except that it was explained to me that it was a mixed cake." Therefore he fails altogether in confirming Mr. Ayre in reference to the very important question in which he is at issue with Mr. Wells of whether or not he communicated this matter to the public. Mr. Ayre having said last night that he told Mr. Hope there was sesamé in the cake, Mr. Hope comes this morning and says, "I did not know at the time that there was sesamé in it."

Well, now, Gentlemen, that brings me to the particular transaction out of which this arises. I have dealt with the general circulars, and you will judge between Mr. Wells and Mr. Ayre; and, Gentlemen, I am glad Mr. Wells was recalled for the purpose of clearing up his evidence, if there was any doubt about the matter. He says, "I have always myself dealt in pure cake, except on one occasion."

Mr. SEYMOUR: Two.

Mr. FIELD: Two lots, but at the same time. But what is there to show that, because he bought them, he had the smallest reason for supposing that he was buying an ordinary cake when he bought this cake in question? Now let us see what happened. Mr. Ayre, you know, is not content to rely upon his general circulars, but he opens the matter with this special circular—"Triangle Best Linseed-cake. As we are now able to deliver cakes of this brand, we beg to make you the offer of ten or twenty tons, at 10*l.* per ton subject to your reply in course of post. The cakes we are now getting are of superior quality, and we think this is a good opportunity for buying, as they are decidedly cheap." Mr. Wells tells you that when he accepted the offer he understood he was going to get that which he had a right to expect namely, best linseed-cake, and not a composite cake of linseed, and something else. Accordingly he gets a sample; but you know, Gentlemen, what happens here is that which happens very often, the sample is good to the eye and touch, and perhaps even to the taste and smell. We shall see by and by how that may be. But I think I shall be able to show you that the article complained of is not satisfactorily proved to have been made of the same materials as the sample was. Certainly it is not that which I expected it would have turned out, and which you know is very valuable in a case of this sort when it exists, namely, a portion of the same thing. Had the cake, as I think my friend opened it, of which the two tons formed part, been actually manufactured on the 19th of January, and this sample had been one of the cakes taken out from bulk and sent to Mr. Wells, of course the case would have been very considerably advanced. But I shall show you presently that the two tons of cake which went to Mr. Wells came into existence only on the

13th of February, the day they were sent up by the train to Market Weighton (it is not necessary to trouble you at any length with the correspondence), and five tons are received and sent to Sancton; and that is the matter that my friend was so anxious to put that letter in about, because he hopes by and by to twit me; well, I won't say twit me, but rely upon when he is addressing you by and by. That was why that matter was pointed out by Mr. Seymour to Mr. Wells with reference to the other five tons that went to Sancton Farm. It is clear that that five tons was not the same specific thing made as this was, but it was not as if it had been five tons in existence, and that the two tons were part of it; because you will find the two tons were not manufactured till the 13th of February. The five tons go to Sancton, and I will deal with it by and by, when I am touching upon the elements of food at Booth Ferry and Airmyn Pastures; because it will come in more conveniently then. Then the five tons having gone to Sancton, Mr. Wells is without cake on the 12th of February, and his position has been this—that, with regard to Booth Ferry Farm, where his feeding beasts are, he has been out of cake for about seven days, and, with regard to the Airmyn Pastures Farm, for about a day or two days. He is anxious to have his supply forwarded, and he goes to see Mr. Ayre for the purpose of getting them forward. He pays his money before he goes there—10*l.* on account on the 7th, and 5*l.* is paid at the time of the interview on the 12th.

That brings me to the question of the interview of the 12th, which you will have to decide upon as to the credibility which you attach either to Mr. Ayre or Mr. Wells. I need not tell gentlemen of your experience that numbers must not be weighed against individuals. The interest, you know, of the two brothers will be one and the same; the interest of Mr. Wells you will see and take into account; and I think when you come to consider what I have before observed with reference to Mr. Ayre's conflict of evidence with the other witnesses, you will have no difficulty in coming to the conclusion that Mr. Wells's account is accurate, and that Mr. Ayre's account is not to be depended upon. One of the Messrs. Ayre says, "I told them there was *sesamé* and bran." On the contrary Mr. Wells says, "Until the interrogatories were administered in the action I never heard that there was such a thing as *sesamé*;" and no other persons are to be found here who ever heard of the introduction of *sesamé*—neither Mr. Hope nor Mr. Glover. Therefore, if Messrs. Ayre did tell Mr. Wells that there was *sesamé* in the cake upon that particular 12th of February, he was the first person, as far as we can judge, they told that to. Mr. Wells you know denies it; he says there was a conversation with reference to the bran in which he adopted a position which I think common sense would lead him to—making a remark of this sort, "Well, if bran is to be put in, the farmers are able to buy it at a much cheaper rate than 10*l.* a ton." It is for you to judge and not me, but that appears to me to be a much more natural account of the conversation than the one which I have ventured to characterise, which was given by Messrs. Ayre. That being so, the two tons in question were put on the rail. Now, of course the Society have no means—they cannot go upon Mr. Kidd's premises—of checking his manufacture or any statement that may have been made with reference to it. All they can do is to ask such questions of Mr. Kidd and other persons as may throw light upon it; and, therefore, it was not until I asked the questions I did yesterday that one could see what their course of business is. But I say this, it is established upon the book which was put in yesterday, that the 8th I think, but I will not be quite sure, was the last day of the manufacture of either "pure," or "genuine," or "best," I forget which, but between the 8th and the 12th, they were doing nothing but "pure," and on the 12th a certain quantity of ordinary cake was made. I beg your attention to that—the very day before these two tons were made—the mill

was engaged in making ordinary cake; and do not forget that in that ordinary cake the siftings go as a part of the manufacture. Therefore, you have the presence of foreign material produced by these siftings, brought at all events into close contiguity with the very two tons that are now in question before you, because the very day before that mixing process was going on the ordinary cake was being made. On the 13th the cake in question was made; only two men were employed upon it, and you have this further fact, recollect, to show that those two tons first came into existence on that morning, that Mr. Ayre says he told Mr. Wells on the 12th that the cake was not then made. So that on the 12th they begin to make it, on the 13th a certain quantity is made which one of the witnesses said would go out that day. It did go out, and these are the two tons you have to deal with. Now what happens next? Let us glance over Mr. Wells's position? You have had before you—I am not going to weary you by going into particular details—himself, his bailiffs, his farm-servants, and everybody connected with the farm. You will judge, of course, how they gave their evidence, whether truthfully or not; and by the cross-examination my friend administered you will judge whether you can depend upon what they said. I venture to think they are witnesses which you will say are to be relied upon. They gave their evidence in a straightforward way, and the conduct of Mr. Wells and everybody throughout from first to last has been entirely consistent with his present contention. Right or wrong, he has persistently asserted the case which I make to-day on the part of the Defendants. Now what were the circumstances, because it is very important when you consider what happened. At Booth Ferry he has feeding beasts—the mode of feeding there being straw picked over in the morning, a bushel of turnips and potatoes about half-past seven or eight, and seven pounds of cake at about two o'clock. That is for the beasts at Booth Ferry. Then besides the beasts there are cows there. Their mode of feeding was this—they had “chop” in the morning, and some mangold the first thing; some more mangold further on, and about two o'clock they had a less portion of cake than the feeding beasts, they had about six pounds instead of seven. At Airmyn Pastures the cake is given to the animals the first thing in the morning, but instead of having there on the occasion in question six or seven pounds of cake which was given at Booth Ferry to the cows, and the feeding beasts, only 4½ lbs. were given. I beg your attention to that because it will be important when you come to consider and compare the degrees of illness and distress which these poor beasts suffered in reference to the quantities of this deleterious article which they had taken into their stomachs. There is one thing more, and then I shall have done with this part of the case for ever. At Sancton, where the five tons went, which my friend was so anxious to bring in, the sheep refused it: they ate it afterwards chopped up, and that was the only shape they would eat it in; and the beasts who took it had only 3 lbs. of cake between them, and that cake was mixed with “chop.” To my mind it confirms my case, and is an argument which, if my friend had not used, I should have used myself, as confirming the cause which I assign the illness of these animals to. Now let us see how far I am justified in that. First of all, there can be no doubt I think at all that what produced the illness was the cake; and I do not think my friend can or will dispute it. There is only one witness who put any doubt upon it, and he was clearly mistaken in his facts—that was the veterinary-surgeon, Mr. Holmes, who put it down to the subsequent feed of turnips, which he said the animals got. But I think you will find beyond all doubt that they never got any such subsequent feed.

Mr. JUSTICE BLACKBURN: I looked back at my notes, and no doubt the evidence of the witness who fed the beasts is that he had just fed three of them with potatoes, when he found that the fourth was ill, and then he

found they were all ill, so that the potatoes given to the third could not have made the fourth and the rest ill—that is very certain.

Mr. SEYMOUR : The mangolds were given twice.

Mr. Justice BLACKBURN : I think not.

Mr. FIELD : Gentlemen, my friend is in error, the beasts did not have mangolds at all. It was only the cow, and I say—with the exception of Mr. Holmes, who attributes the illness of the beasts to the taking of the turnips, which they never did take—nobody doubts for a moment that the eating of the cake was the immediate and proximate cause of their illness. The only attempt made to dispute it is in this way : a question is raised, whether that cake produced the effect itself, or whether it was pure, good cake, and the effects were induced by something which had happened before in the feeding of the animals. Now, Gentlemen, you know we have all along said that which I say to-day ; chemical analysis is no test at all of the poisonous or injurious qualities of the thing analysed. All seeds and vegetable matters contain the various things that are described in this analysis ; they all contain moisture, they all contain oil, they all contain albuminous compounds, mucilage, sugar, digestible fibre, &c., &c. : be they good or be they bad, be they health-giving or be they death-giving, the chemical analysis will show the various proportions in pretty nearly the same figures as they exist in the one case or the other. Now, I beg you to recollect that, because it is what Dr. Voelcker said when he gave the analysis in his Report ; it is what you have heard from all the witnesses on our side, and it is what my friend has not ventured to contradict. Therefore, you know, all my friend's criticisms, if he is going to administer any, upon the various component parts come to nothing if they do not indicate what the quality of the thing is. The illustration given to you by Dr. Voelcker in that respect was perfect. "Take castor-oil," he said, "analyse it, and you will find so much oil, so much mucilage, so much albumen, &c., exactly in the same proportions as you will find in good olive-oil ; but besides that the castor-oil contains a property which never yet has been traced, or can be traced, as to what it is, for science has not yet gone so far as to enable chemists to find that out ; but that it contains a poisonous property is known in the same way as the poisonous property of this cake is known, namely, by the consequences that follow from the administration of it. You may give beasts the same identical proportions of moisture, oil, albumen, &c., in the shape of olive-oil, or castor-oil, and, *à priori*, before the administration you shall not be able to tell one from the other, as far as regards chemical analysis, but the effect is the test." "By their fruits shall ye know them ;" and if you find that they do bring forth, as this stuff did, disease and death immediately after administration, can you for a moment hesitate or doubt—unless my friend can show you some other ground to rest your verdict upon—that it was the cake which caused the mischief ?

Now, let us see how that is. I will take first what had been purchased in the previous October. The cattle had been brought up then for the first time from grass, and therefore the change of food from that which they had been used to, spoken to by the file of veterinary surgeons whom my friend brought from Leeds and the neighbourhood, was the most sudden that you could well imagine. They were brought from the grass, tied up in stall, and given 7 lbs., 6 lbs., and 4½ lbs. of cake, according to the different modes of feeding the very first time they were brought up. Did it harm them ? No. They had their potatoes in the morning, and the cows had their mangolds, which we hear so much about, and they took it and continued to eat that, day by day, and enjoyed it, and were perfectly well and healthy up to the morning of the 16th of February, when they ate this cake. Now, let us see further what happens. I used the word poisonous. I am sure my friend will not misunderstand me, or will not suppose that I intend to assert thereby the existence of active

poisons in the cake. We do not assert that there is any mineral poison, but we do assert that there are narcotics or other vegetable matters arising from these seeds; and when I use the word, I mean the effect produced on the animals. Now recollect, first of all, with regard to the number of animals—you have 52 individual beasts who suffer at once from the administration of the cake. Was it because they had been off their feed for a length of time? Was that the cause of their illness? No; those that had been off for five days only, suffered the most. The cow was one of those that had been off its food for five days, and it died. Was it position? They are in two different positions one from the other. Was it system of feeding? The system of feeding is different at the different places; in the one place they have their cake in the afternoon, in the other place they have their cake in the morning. Was it age, or a structural injury? No; we are able, on account of the loss of the cow, to give you, by Professor Simonds, the state of the animal that suffered most, and he tells you clearly and distinctly—and my learned friend will in vain endeavour to get rid of it—that there was no trace of any structural or organic disease whatever, and that all the intimations he found there were intimations of blood-poisoning, arising, not from the administration of direct poison to the blood, but by the impossibility of the blood getting decarbonized, in consequence of the impairment of the functions of the nerves of the rumen—it being, therefore, directly attributable to the deleterious matter which was found in this cake. Is it likely to be so? Why, Gentlemen, one of the veterinary surgeons who was called on the part of the plaintiff, expressly pointed to the deleterious articles as being the cause of the tympanitis or hoven, of which we have heard so much. I forget his name, whether it was Mr. Freeman or who it was, but you will recollect it by and by, when I call your attention to the circumstances—he distinctly said, after going into the question of over-dosing and gorging and that sort of thing, that articles foreign to food, such as pins and needles, and bits of wire, and things of that sort, were the cause in one of the cases of hoven that he met with—pointing to the identical thing which is suggested here, and I think proving to you in this particular case that our suggestion is correct.

Well, then, it is said the class of food was the cause. Is that true? No: it is equally unfounded with the rest. Mr. Holmes placed great reliance on the mangolds being the cause, and although my learned friend never asked any of my people any further question than this, “Were they exposed to wet?” they told him no, that they had been carefully piled and thatched, and then taken into the shed, and from thence taken to the beasts. He never asked whether they were sprouting, or moist, or growing, in the way that Mr. Holmes suggested; and you have no evidence whatever from which to infer such a thing. But what does my friend say as to those twenty-four beasts who had no mangolds at all? If therefore the sprouts and the sugar in the mangolds are to account for it, how does he account for those who never had any—the beasts at Booth Ferry or the beasts at Airmyn Pastures, which had no mangolds? What had they then? Because, of course, my friend says potatoes and turnips are just as bad. But what had they? They are divided into two classes; at one place, at Booth Ferry, they had a bushel of potatoes or turnips at half-past seven in the morning and they had no cake till two, and the scientific witness called by my friend, who had heard all the evidence, and asserted that the feeding was the cause of the evil, gave to my Lord four hours as the maximum time during which by possibility the cake could operate on the turnips and the potatoes. Half-past seven—say eight o’clock—eight and four would be twelve. Gentlemen, they did not have any cake till two, and therefore his theory is out of the question. But what will my friend say to the beasts at Airmyn Pastures? They had their cake at half-past seven in the morning by itself, and at a quarter to eight they were down moaning and distressed. What is

the pretence there? The theory suggested by my friend by his cross-examination of Professor Simonds was this, that the cake operated to set up the chemical action of fermentation with the turnips and potatoes that were there before; but by half-past seven in the morning the rumen was empty, and the witness he called does not give more than four hours as the maximum for the action in the rumen. In the one case they got their turnips at half-past seven and did not get their cake till two, and in the other they got their cake the first thing in the morning when the rumen was empty.

Gentlemen, I am trying to deal with all the heads of argument that my learned friend is likely, as far as I can judge by his cross-examination, to put to you in his reply. He did not quarrel with the mode in which the farm of Mr. Wells was carried on; he did not cross-examine or call any witnesses except one upon that, who says that 5 lbs. was too much. We show you that 5 lbs. was a moderate quantity by the evidence of Mr. Wells and his two bailiffs, who have been with him and his uncle for 35 or 40 years, and have carried on the farm all that time with very great success, and it is not suggested for a moment that this thing ever occurred before. Is it to be supposed that these beasts had never been without cake before for an interval of time, and that hoven and tympanitis, if that was the cause, would have been as frequent as some of the veterinary surgeons say it is whenever beasts get into a field of clover or at a pile of new-mown hay? Do you think that would not have occurred before? And what is more, if it is to be a question of time, I ask you to look at this—the same animals were without cake for as long, or a longer period of time than the cows at Booth Ferry were without it, they were put on immediately again with their 6 or 7 lbs. feed of pure and good wholesome linseed-cake, and they stood it well, and are in perfect health up to the present time. That happened at one place twice, and on the second occasion it took place after an interval of ten days, without any injury of any sort or kind. Gentlemen, you know, had there been any substantial conflict in point of science between Professor Simonds, whom I called, and the veterinary surgeons called by my learned friend on the part of the defendant—had there been, which there is not, any substantial issue of fact or science between them, I should unhesitatingly have appealed to your common sense and knowledge of farming to say that the account given by Mr. Wells and Professor Simonds is the accurate and correct one, and that it is impossible to assign, as far as I can judge, any cause whatever for this death and distress amongst Mr. Wells's beasts that can be in any way due to aught but the administration of the cake itself. The same course that has always been adopted is adopted on the occasion in question; the same course is adopted afterwards, with perfect innocence and harmlessness on every occasion except this one. My friend, I suppose, will say my argument is *post hoc ergo propter hoc*; but did you ever find cause and effect so immediate at both places—in three-quarters of an hour, before the man has had time at one place to give them their potatoes; and three-quarters of an hour at the other place, where the beasts are just as bad exactly in the same way? It is so immediate, so direct—what else can it be due to? Unless my learned friend can satisfy you that it is due to some other cause, what can it be due to except to this unwholesome cake which was given to the cattle?

Now the next question we have to consider is, Is there in the cake that which would lead you to this conclusion? and to consider how far my learned friend was by his evidence negatived the existence of any such ingredients. First of all, you will recollect I have proved by three or four witnesses the existence in this cake of foreign articles—not the seeds growing with the linseed, but different things in the shape of wheat, cocoa-nut, mouldy wheat, husks, and things of that sort, which could have no business there unless they were put in in some shape or other. Now, does my learned friend by his case negative

the putting into that, either by accident or mistake, or some other cause, by some person or other, for whom Mr. Kidd is responsible, although without his knowledge, of these articles which proved so injurious on this occasion. You know, first of all, we find a considerable quantity of seeds, and the chemist tells you that, in the present state of science, it is impossible to say what injurious properties they may possess. There are some of them, the wild mustard, and darnel, and some others, that are unquestionably injurious, but science cannot point out their effects. Then, with regard to the actual quantity of seeds, or the proportion, as my friend put it, recollect you have got to judge of the ground portion in the cake by those which were found unground. It is not merely the unground seeds and husks which are found there that constitute the injurious property of the cake, because, as Mr. Kidd told me, "If I had thought right, I could have ground it up in such a way that nobody could have discovered what it contained." Therefore you know it might be so ground; and recollect further that the sesamé-cake is ground by a different operation, if I understand it rightly, from that which combined the two cakes together.

We will see how that is. With the exception of Mr. Kidd and his people, and the production of the sesamé-cake without any opportunity of examining it or of having any analysis made of it, we have had no account of the sesamé-cake, or what it contained, given at all. It was bought in November. It is an article made in France. No vendor or broker through whose hands it passed is called, but I will put it to you thus: If the elements are there, what is there to show that they were not contained in the sesamé-cake? To begin with, we have no account of it. They have had it, and could have analysed it if they pleased. They could have submitted it to a microscopical examination if they pleased, and what they do is not to say a word about it in the early part of their case; but this morning, for the first time, they produce some of these sesamé-cakes and hand them to you as some evidence of what they may be. Gentlemen, it is impossible upon any examination which we could make to-day to judge of that.

But you have further the siftings which are brought into separate existence in contiguity with this very lot of cake, and if you find that these things in that way may have got into the cake, and the chemists and medical men that we have called satisfy you on the other hand that they are there and caused the injury, can you doubt at all that it is so, and that, therefore, that assertion in the Report is proved that the cake was composed of the various articles mentioned there, apparently made from dirty linseed and the sweepings of warehouses? Dr. Voelcker and Professor Way made their analysis together. Mr. Tuson made his analysis separately. Mr. Fairley made his analysis separately. They have had no communication with each other, and they all concur. Mr. Tuson says, "I found, besides linseed, grains of wheat, rye-grass seeds, dodder and millet seeds, the husks of wheat, barley, oats, rice, cotton seed, and cocoa or palm nut." They have had the opportunity of calling anybody they please to contradict him, to examine the cake which he spoke to between the time it was produced here and to-day; they have called nobody, they have it upon the evidence of the gentlemen that we have called, and it is therefore clearly established, as I venture to submit to you, that these things are to be found in the cake. Then if these things are found there, are they or are they not injurious? Can you have a doubt of it when you see what the consequences of its administration were?

Well, Gentlemen, I think now I have almost exhausted what I have to say to you, because I do not wish to weary you or to detain you longer than I ought; and yet, of course, I am very anxious to deal with any observations which I think my friend will be likely to make against me. There is one other topic which has been urged, and that is over-feeding, or over-gorging as



it is called: let me say one word to you about that, if it does not answer itself. They had always been accustomed to 7 lbs. of cake, and they had 7 lbs. on this occasion; they were taking their usual time to eat it. The question is asked and denied—they were not hungry, they were merely taking their usual food; and what is more remarkable is that four stones were left in the troughs; therefore they did not eat it all. 7 lbs. was the dose, which was not too much had it all been eaten, but they had not even eaten that amount, and, therefore, the ravenousness is disproved, because they had left a portion of it there. The observation on that ground, therefore, entirely fails.

Then, with reference to the 5 tons delivered at Sancton, look at the difference in that case. It goes far to prove our theory. You see animals of this class have a rumen or first stomach; of course if you expose that to the action of nothing but deleterious cake by itself it operates more directly on the nerves of the stomach; if you mix that cake up with chopped stuff of any kind it has not the same effect; it does not rub against the coats of the stomach, and does not, therefore, stop the peristaltic action. Therefore it is that at Sancton you find all the difference. There they had no more than  $4\frac{1}{2}$  lbs., and that was mixed with chopped stuff, which would tend to take off the effect of the cake. The sheep in that case, you will recollect, in the first instance rejected it, and only took it after all in small quantities and mixed up with "chop." But, Gentlemen, again my friend says I will show you how harmless this is, because I will call people who have used these 8 tons of cake which I say is the same as that of which you complain. Now there is no proof whatever that that 8 tons of cake were manufactured at the same time as the 2 tons on the 13th. All we know is that, on the 19th, that 8 tons of cake were put on board Fearnley's boat. When they were made we are left entirely in the dark: we do know that the 2 tons were made and sent out on that day, but what happened in reference to that 8 tons we cannot say. But let us see what the evidence is upon that. The 8 tons are divided amongst three or four cowkeepers, who administer it to their cows. It is done by way of a test, and I cannot help thinking that the same offer should have been made to us as we made to them, namely, to make these experiments in common, at a time when both parties could watch them and see their true results; but what is the effect of the evidence given in this matter? We have, I think, four cowkeepers called; Mason has six cows, and he only gives them  $4\frac{1}{2}$  lbs., which in the case of Sancton, you know, was harmless; Roundtree had 1 cwt., and he only gave about half-a-cake a-day to five; and Smith had six cows, and he gave one cake amongst them; and Hornby had a cake amongst three, and he gave them half-a-bushel of bran just before they ate it. Now compare these experiments with the actual facts—not experiments—which we have proved, and ask yourselves whether or not my friend can satisfy you that these experiments at all indicate that the death in question was not due to the particular cause to which we assign it, or was due to some particular mode of feeding which he says, he would have you believe, was not judicious on our part.

Well, then, you have the evidence of the three scientific gentlemen whom I have called; you have the evidence of Professor Simonds, who told you what the cause and effect are in this case, and I will say this: Professor Simonds' evidence excludes every cause that can possibly be suggested except that of the presence of deleterious foreign matter which ought not to have been in this cake; and, therefore, in these circumstances, can you come to any other conclusion than that that was the real cause of all this mischief? You know it is only theory and suggestion on the other side that fail when you come to examine them.

Gentlemen, I think now I have gone, as shortly as I could, through the

important facts of this case. I may have omitted many things which I ought to have said, but I trust to you to take them all into consideration. Take both parties into your even hands and weigh them both; and when you hear the libel read, I ask you to find that the Society on this occasion, in their honest effort to protect the fair dealer and consumer, have not trespassed beyond the rules of law and justice, but merely done that which they have abundantly proved their right to do, and are, therefore, entitled to a verdict at your hands.

Mr. SEYMOUR: May it please your Lordship, and Gentlemen of the Jury; the day is now far spent and we are at the close of three days of a most important and anxious inquiry. I will endeavour therefore, in the course of my observations to you, in replying on the part of the Plaintiff so to shorten my speech to the best of my power as on the one hand not to do injustice to my client, nor yet on the other hand to weary you by any lengthened remarks.

Gentlemen, you have had your attention called by the cross-examination which each of the witnesses has been subjected to by my friend's observations and by my own in the course of this case to the main issues between us, and undoubtedly they are issues of very considerable importance. When I first addressed you, I told you I made no charge against the Council of the Royal Agricultural Society or against that distinguished body itself of being animated in this matter by any personal spite or indirect motive against my client, Mr. Kidd; but what I did say and what I now repeat is this, that great companies, whether corporate or otherwise, like individuals who are the employers of agents, cannot complain if sometimes they are made responsible for the hasty indiscretion of those who are identified with them in the exercise of various functions, and if they become responsible in the eye of the law for those who, acting without sufficient patience and care, by their language or by the publicity which they have given to a hastily formed opinion, endeavour to undermine or prejudice the character and good fame of others. And, Gentlemen, I think I was entitled in my opening observations and I feel I am entitled now to complain, that although we did repeatedly ask for it, there was a disposition shown on behalf of those who represented the Agricultural Society, not to afford us that frank opportunity of independent test and analysis which at least we show by our correspondence we were anxious to resort to. It is all very well to say—"We will publish along with the opinion of Dr. Voelcker the result of any analysis which may be made by some third party." Why, it would be only repeating the mischievous publication of Dr. Voelcker of which we complain, and circulating it side by side with the report of the analyst employed by my client, thus giving additional publicity to the libel! It is all very well to say, let a joint analysis be made, provided Dr. Voelcker takes part in it; but it only becomes a useful analysis so long as Dr. Voelcker unites with the man who makes it—if he differ in the mode or conduct of the analysis, why, at once, the test fails. Again my friend says, you have no right to complain: you had the 8 tons out of which you might have made a selection of a sample to have made your analysis upon. Now, just see the fallacy of that argument! For it is scarcely two minutes ago that he who twitted me with the possession of the 8 tons, as the means of getting an indisputable test, actually put it to you that there is no satisfactory proof that that 8 tons was part of the same specific article as the 2 tons or the 5 tons which went to Mr. Wells's farms. Thus you will see, Gentlemen, how far I was entitled to make the remark which I did in the first instance; and what I venture to say is this: the correspondence shows that there has been a too great readiness to listen to the complaints made and the theory originally set up by Mr. Wells, on the part of the Secretary of the Company; and that which I think strongly corroborates the observation I made, is when he speaks of the position in which he was placed, for in the letter of the 23rd of March

he writes this:—"Our position is that we have published a libel consisting of facts supplied by you, and we must therefore look to you to verify those facts and thus substantiate our plea of truth and justification." So that on the 23rd of March, when questions are being asked and interrogatories are being put by the Secretary to Mr. Wells, his attention is being called to the condition of the beasts on the Sancton Farm and to the question of whether he gave them fresh mangolds. Another letter, written next day, shows that they are making inquiry. That is on the 23rd of March, whereas on the 11th of March had gone forth to the public this grave imputation involving Mr. Kidd obviously on the face of it in the serious charge of having manufactured cake which was as bad as the bad linseed-cake supplied to Mr. Eaton, which justified the Defendants in classing his cake under the head of "so-called poisoning," and as being made from "dirty linseed and the sweepings of corn warehouses." Gentlemen, I venture to say that you will agree with me that my comments on that part of the case are fairly deserved, and although I do not make a complaint of the body my friend represents, I do submit to you that the letter of the Secretary shows that they lent too ready an ear to the whispers or charges and complaints of Mr. Wells, and that it would have been better for them, before publishing this Report, to have placed themselves in communication with Mr. Kidd, in order that they might ascertain what the real facts were. There is one other thing also which I think I ought to mention; if they had remembered the character of the circular, issued by Mr. Ayre, it is impossible that any one who was preparing a fair report could have inserted this—"A small sample of this cake had been sent before purchase to Mr. Wells as Best Linseed-cake"—the cake had been sent to Mr. Wells as " $\Delta$  Best Linseed-cake;" and although the matter may be simply one for observation or comment, still on a question of accuracy, dealing with the class of people throughout the country amongst whom this libel was circulated, and who know what the meaning of these words is, I think I am entitled to submit to you that it was not a correct description of this cake to say that it had been sold as "Best Linseed-cake" when it was sold as " $\Delta$  Best Linseed-cake."

But, Gentlemen, that is not all. You have a statement here on the face of this libel, that this cake was sold as Best Linseed-cake. Now that would convey the idea that it was sold generally, and that the parties who were dealing in it were supplying it to the public generally. But, so far as Mr. Kidd is concerned, it is perfectly clear that this cake was supplied by him to Mr. Ayre; and although I am not here for a moment to say one word which is not entirely in support and vindication of Mr. Ayre, yet I am here, and I am supported by my friend in the observation I am going to make to you—I am here to say that Mr. Kidd is the manufacturer; that the circular was sent, and the letter written by Mr. Ayre to Mr. Wells, and that they are not things for which he is in any way responsible, or as to which he was consulted in any way whatever. What he sold he is responsible for, and what knowledge his customer possessed he is responsible for, and it is perfectly obvious in this case, that, so far as Mr. Kidd is concerned, what he sold to Mr. Ayre was that which Mr. Ayre knew the component parts of; he knew it from Mr. Kidd when he first entered upon the preparation of this particular article; they discussed it years ago—the proportion of linseed, the proportion of sesamé, the proportion of bran, was a matter arranged between the parties when they first commenced the making of this "Triangle Best Linseed-cake." Therefore, Gentlemen, I say I agree with my learned friend, and I think it is a matter worthy of your attention, that it is more or less a bye issue, if you are to allow Mr. Kidd to be in any way affected by any question as to whether the circular that was sent round and advertised, and circulated by Messrs. Ayre, Brothers, is not as full and as distinct as if you were preparing it now in the light of this trial, you might have thought it wise to prepare it. But

while I make that remark, I do not shrink from my position of maintaining that the circular which is in my hand, with the knowledge which must have been in the trade, and this is issued to the trade only—it is a circular sent round by Messrs. Ayre, who are dealing with the trade, and who do not themselves ordinarily supply the farmer, but supply throughout the country those who, like Mr. Hope of Northumberland, and Mr. Glover of Warwick, deal with them. This circular clearly conveys to them that there is a difference in price and quality between the various articles mentioned in it, and that this particular cake, here described as “ $\Delta$  Best Linseed-cake,” is a cake which is neither “genuine” linseed-cake, nor “pure” linseed-cake, but is, as you have heard to-day, in the language of Mr. Hope, a cake with a particular brand, the  $\Delta$ , and a particular trade description “Best.” That is something which is known in the walks of commerce and in the trade as a linseed-cake, but which is distinguished from genuine and pure linseed-cake by the brand, and by the description “Best,” as distinguished from the descriptions “Genuine” and “Pure.” If that be so, if the circular fairly conveys that to those who receive it, I submit to you that it is not justice to the manufacturer to complain, as my friend Mr. Field has done, and to comment upon, and to criticise in the way he has done, the language of that circular. We all know that a gold chain may or may not have the nineteen or the eighteen carats of gold, it may have only half the pure metal, and the rest may be alloy, yet are you to say that if that chain is sold by the retail dealer or jeweller, and described as a gold chain to his customers, that it is to be made a complaint against the manufacturer who sells it, and makes his profits upon it, for that which is known as a subject-matter of trade and commerce, dealing with those who know what it is, and have every opportunity of testing its purity and character before they give the price which they pay for it? Gentlemen, I submit here you have the testimony of Mr. Kidd and Mr. Ayre, and the testimony of these circulars, you have the testimony of Mr. Glover, and Mr. Hope, and the other witnesses, which is not contradicted in this case (for my learned friend has not called a single witness to show the contrary), that in the circles of those who trade in this cake throughout the country, and who are the great purchasers of it, there is a known article of commerce which has the name of “Triangle Best Linseed-cake,” the price of which indicates that it is neither “Genuine” nor “Pure,” that it is known to be more or less a mixed or compound article, which, therefore, in the absence of all evidence to the contrary, you must take as carrying with it a certain specific warning and caution to those who purchase it, that it is not “Pure” linseed-cake, nor “Genuine” linseed-cake, that it is a good sound cake, but that it is composite in its character. Then if that be so, I venture to say the first part of this inquiry before you, that which bears upon the issue, whether this was sold or not as a Best Linseed-Cake, is easily disposed of by the remarks in which I have summed up that part of the case; because I am not going to labour before you what it appears to me in this trial would be merely prolonging it, by wandering into unnecessary and uncalled for matters. I am here representing the manufacturer, Mr. Kidd, to whom it is a matter of enormous importance whether the issue is proved or not, that he turned out from his works at Hull that which was poisonous or deleterious in its character, that which was a dirty cake, composed of the sweepings of warehouses, either wilfully or by gross negligence mixed up with a lot of screenings, so as to render it deleterious to cattle, causing their death, or at all events spreading mischief and disease amongst them.

Now let us see how the evidence stands upon that. It may easily be divided into two or three heads. You have the chemical evidence and analyses, and, no doubt, so far as the history of this case in the trial goes, the

chemical evidence and analyses have been on my friend's side. I have told you and called your attention to this: that we were most anxious to have the opportunity of getting an independent analysis of the very cake inculpatated; but we have not had that afforded us. My friend has called his professors and chemical witnesses upon that point; and let us see in what position they land us. My friend says, attach no weight to the result of the chemical analysis—it proves nothing. The component parts, as ascertained by chemical analysis, may be health-giving, or may be death-giving, but their quantities and their decimals are the same, and they will mislead you. Gentlemen, I protest against that argument, and I will ask you just for a moment to see if it is a fair one. In the first place it is obvious that there must have been some useful object in submitting it to chemical analysis, otherwise the Defendants would not have gone to the trouble. I suppose I may take it for granted that it was anticipated and believed that some useful end would be served, otherwise why should a chemist be employed, and why should this cake be submitted to his critical tests, and to the experiments which he would make upon it, for the purpose of discovering its component parts? Dr. Voelcker, Mr. Tuson, and the other gentlemen who were called, eminent in the walks of science, were called in for the purpose of making a chemical as well as a microscopical analysis. Therefore I think we start with this: that those who proposed the test and suggested the inquiry must at least have had an object in view in obtaining this result. Now what is the result at which they arrived? I find, gentlemen, that this cake, upon which the cattle of Mr. Wells were fed, yielded:—

Of oil .. .. .	13·06
Of albumen .. .. .	27·68
Of mucilaginous compounds .. .. .	25·68
<hr/>	
Making a total of .. .. .	66·42

and, Gentlemen, I find that according to an analysis which we made of pure linseed-cake—nothing but linseed in its purest and simplest form without any admixture, and made as pure as it could be, for the purpose of testing the figures which were given on the 16th of June, 1872, by Dr. Voelcker, very nearly the same result is given within only a few decimal points as the culpated and accused linseed furnished, which they say caused the death of these cattle. Gentlemen, I find further that when Mr. Tuson, who gave his evidence in support of the Plaintiff's case, was examined, he gave us this analysis:—

Oil .. .. .	12·67
Mucilage .. .. .	27·64
Albumen .. .. .	33·48
<hr/>	
Total .. .. .	73·79

and that the proportion of nitrogen was some decimals higher than the nitrogen which was found in the pure sample tested by Professor Voelcker in June, 1872.

Well, what result do you get from that? My friend says, treat it as nothing, get the poison out of the question, and that which was deleterious may do no mischief, and that the analysis may be an analysis of death-giving ingredients or of health-giving ingredients, and will produce the same result as far as the analysis is concerned. But pause a moment; look at the other side of the question. If there was so much of deadly poisonous elements there, from which such a yield of oil, albumen, and mucilage could be derived as to give a product and a result equal to more than the average of

the best ordinary and purest linseed-cake, should we be driven to the nic analyses of these chemists, who under the microscope discover a few seeds of dodder, or a few dozen specks of darnel, or other similar component parts of substances like that? If you are to solve this theory, or rather to get over this fact, that such a yield of oil, such flesh-forming and flesh-giving ingredients, were found in this material, is my friend to say that a substance that may be poisonous? Are not you to remember rather that this is the answer to my friend: that on the other hand these professors tell you they cannot definitely, even to the fraction of a fraction, a decimal out of a hundred, by any proximate degree of arithmetical calculation, tell you what quantity of any of these things they discover? Therefore, you come to the extraordinary and enormous absurdity—that out of a large sample of the cake which is placed before the chemist, which he analyses and reduces to its components with his microscope, yet he is able only to discover such motes or grains as these, some article like millet, something like the husks of rice, something like dodder or darnel; but he cannot tell you even approximately what proportion all that bears to the whole; and yet you have all those vital ingredients found by the chemical analysis in that very cake. Do not you think then I am entitled to say that the solution of such a result is, that you must place confidence in the truthfulness of what my clients tell you, namely, that there was in that cake 50 per cent. of all but pure linseed which only wanted another screening to make it quite pure (for the evidence is, that it was linseed twice screened, and therefore linseed which was only not of the highest degree of purity, because it had not a final screening) 50 per cent. of that, and added to it the other elements of which you have heard, namely, sound good sesamé-cake imported into this country from good makers, of a sound and wholesome material, which in itself is an oil-giving and fattening product, and an article of commerce known widely on the Continent, being the result of the expressing of salad oil from seed for the use of man. I say if you find such an ingredient as that costing 6*l.* 10*s.* a ton and good wholesome bran costing 5*l.* 15*s.* a ton; if you find those two elements added to the pure linseed, as upon the oath of Mr. Kidd and the other witnesses who have been called before you they are, why then the chemical analysis does become important. Because in place of groping in the dark, and endeavouring to reconcile how this cake can be poisonous, or what are the proportions of the poisonous ingredients of which fancy suggests it is composed, instead of having to deal with these microscopical calculations, the result of which cannot be approximated by any known arithmetical symbol, you have the positive oath of a man, who produces his invoices, who produces his books, who refers to the dates when these ship-loads of materials arrived and solemnly here in a court of justice gives his evidence under those sanctions which a man does who knows when he quotes the names of vessels, the deliveries of cargoes, and the transactions with large houses of business, that he is stating that the refutation of which he could be confronted with to-morrow if he were not telling the truth—I say when you have from the lip of Mr. Kidd, and Mr. Ayre, and their witnesses, proof of the 50 per cent. of linseed, the 30 per cent. of sesamé, and the 20 per cent. of bran, and the evidence of the existence of materials known to chemical science as oil-giving mucilage-holding and albuminous compounds, are you to listen to my friend when he asks you to disregard altogether the chemical analysis, simply because he will not for one moment listen to the possibility of truth on our side, truth which, if you believe it, entirely supports and vindicates the analyses of my friend's own witnesses, and accounts for the proportions of the materials in the cake of which you have heard? So much for the assistance which chemistry has rendered to our case.

We now come to the help which the microscope has given us. What has

it done? It is notorious in the purest linseed, screen it as you will, you will find some elements such as dodder, darnel, *Polygonum*, *Lolium temulentum*, and all those various things which grow with the linseed. They come from Calcutta, they come from St. Petersburg, they come from the Black Sea. It is part of this article of commerce, and you cannot prevent the linseed from being more or less affected by the presence of these foreign vegetations in the quantities of it which are imported into this country. And what is the result? Why we have this proved: that there is in London an association composed partly of the importers, partly of those who represent the great agricultural interests of the country, and partly of retailers, who have formed what is known as the "Pure Linseed Association," and they have laid down a standard which rules in this way: pure linseed is linseed which only yields a certain percentage, 4 per cent., of foreign elements, weeds, or foreign growths, which come in with the bulk of the linseed; and they say this—if when a cargo is delivered to you, you find you have got seed which has got 4½ per cent. of these foreign elements in it, then you ought to get a deduction of a half per cent., or a return from your price to that extent. But if you get a cargo which is of such purity that it only contains 3½, then you have to pay for that extra half per cent. difference, because you have got the benefit of a purer article. That is the test and the principle upon which they rely; and you have it proved in this case, because Mr. Kidd produced before you the certificates of the Association, that upon some of the very linseeds used for making this cake he had to pay and not to receive, showing the high class and purity of the linseed that he received. Gentlemen, I am therefore asking you, when you come to look at this question of the purity of the linseed, to recollect that, call the cake what you may, the purest and the most absolutely unadulterated linseed that the wit of man or the skill of manufacturing science can produce for the use of cattle in England, if put under the microscope, you will find dodder, darnel, and *Polygonum*, and twenty other of those foreign elements which grow with its growth, mature with its ripeness, and of necessity form a portion of the bulk of the seed as it is imported into this country. You will remember in the glass bottles which were produced yesterday, you had specimens of those various linseeds—the pure and the other qualities—for you to use your own eyesight upon, and I hope you will not fail to exercise it for the purpose of discovering that even the naked eye can detect in the purest linseed the presence of these foreign matters. Then in what way does their microscope help you? Does it help you to the conclusion that this cake had more foreign elements than pure or twice screened linseed ought to have? Is there a gentleman in that box who will make that experiment in common justice to my client, who will see what the number of these dodder, darnel, and *Polygonum* seeds is in those indisputable samples of good honest seed? When my friend talks about *post hoc* and *propter hoc*, why it is his argument, not mine, to say that because the cattle died after eating it, therefore the cake must have poisoned them! I say, let us go further and see if there may not be other causes which would account for the death of that one animal and the injury to the others. What I put in this case is that, by and by, when you are considering the question how far chemistry and the microscope help you, you will remember that the chemical analysis supports the positive affirmative evidence of Mr. Kidd, and that you never can accept the theory that there could be that proportion of flesh-giving useful nutriment in that article, with the oil, and the mucilage, and the albuminous compounds shown by the chemical analysis, impregnated with poisonous ingredients, unless you could have found, or unless the eyes of those Professors could have found, something more solid to rest upon than the grains or particles of grains which they were able to find under the microscope. And then I ask you further to go with me on this: that all the microscope proves is that which I have admitted, and Mr.

Kidd admitted, that no care, or precaution, or providence whatever, can prevent luscid from being more or less affected with such trifling impurities as a microscope will detect. Then with regard to the other components, there were some mucilaginous particles which one of the Professors told you he found, the little nodules or lumps that you will remember. Well as to the Mr. Kidd told you that the lads who are paring the cakes in order that they may be more convenient as articles of commerce, and to guard against waste throw the parings under the stones, where they are crushed, and in some way or other, not being reduced to the same consistency as the rest of the mass around them, they get into lumps, and so he accounts for the appearance of these little nodules in the cake. I think you will accept that as the undoubted solution of that matter.

Then another gentleman, abounding in his discoveries, thinking perhaps he has almost found a new world, actually discovers bran in the cake! I wish him joy of it. If he had only waited a little longer until our case was fully gone into, it would have told him that bran was a large element (and you probably will not think a great deal of the analysis that did not find any bran), that it was in a proportion of something like 20 per cent. of the whole.

Well, then, we had a theory that there was some proportion of cotton-cake found in the sample that was tested. Now do you recollect Mr. Kidd and his two bottles of oil? Because that was one of those pieces of evidence which let in a great deal of light upon the truth of a case like this. The idea of cotton-cake being allowed, even by chance, to mix with linseed in the crushing of that seed for the production of oil in Mr. Kidd's mill, is demonstrated as an absurdity; because there you had the clear, yellow, pellucid oil in the one phial, which is the valuable article of commerce; and in the other you have the dark-coloured, ugly-looking oil, which is produced from the cotton-seed. Do you think it likely that a man who makes his profit from this oil—because it is not the 5s. upon the 10l. per ton which he gets out of the cake that has led him to put up all this machinery and to establish all these works, but the far more valuable and profitable purpose of extracting the oil—do you think that for the paltry advantage of this 5s. per ton upon this cake he would run the risk of destroying his oil by mixing the dark properties of the cotton-cake with the bright product of the linseed? Well, I think I have said enough to dispose of that.

Then there are a few wheat and oat grains found. Well, Gentlemen, if bran is used in the cake, and it is carried in sacks to the mill, I daresay you will find a few grains of wheat and oats by microscopical examination. So that it comes to this, that when you come to analyse this cake you get results of this most infinitesimal character, which are gravely put to you as elements of adulteration.

Then we have another theory. What is the only element which, with all their botanical knowledge, Professor Way, who is no small authority on matters connected with botany or science, a gentleman connected with the Agricultural Society for years, and whose name at all events was familiar to me when he was called into the witness-box, you have the learned Dr. Voelcker, you have Professors Tuson and Fairley, and other gentlemen called here, and what is the only element deleterious in any sense in its composition which they can find? It is the darnel—to what extent do you find it? A few grains. What is the injurious character of darnel? What makes it poisonous or injurious? It is supposed to be a narcotic; therefore, because you find there a little seed, a quantity of which if in a large proportion might be disposed perhaps to operate as a narcotic—because you find that one element which is the only poisonous foreign substance in any sense which chemical analysis or microscopic test can reveal to your eye, or discover by any process of examination, it is put forward as a justification of this libel.



Then we have heard of dodder. Well, I think Dr. Voelcker has disposed of dodder; because the dodder about which so little is known, forsooth, turned out to be, and was proved by Dr. Voelcker himself to be, a known article of food amongst agriculturalists on the Continent and in this country. Why dodder is as well known in some parts of England and the Continent as inseed-cake! Dr. Voelcker has established the fact that he knew dodder-cake perfectly well as an article of food for cattle, and, therefore, you are asked, because a few dodder seeds, the particular qualities of which the gentleman who found them said he did not know, but which is now proved to be used in bulk for the purpose of cattle-food, to come to the conclusion that it, as well as the darnel, is injurious.

Now that is the position in which you are left; because I venture to say you will agree with me that these comments of mine are entitled to the greatest weight. Take them together with the evidence of those professors, that there is some fibrous matter there, and with the other suggestion that they found some portions of cocoa-nut and other things more or less of a woody character. But if you rely upon that, how do you account for the oil, the mucilage and the albumen in the proportions which I have commented upon as existing in the cake? Because, if they are right as to the degree in which this indigestible or woody fibre, the husk, or fibre of cocoa-nut, the rice-husks, cotton-husks, or any other things of that sort exist, the more true their theory is the more absurd is the result of the chemical analysis which reveals such a different yield of valuable products by the samples which the professor tested.

Well, Gentlemen, I think I have not upon this part of the case occupied your attention more than I was fully justified in doing, but it is to my mind the most important one; and just observe where it lands my friends. Neither the chemists nor the microscopists can help you. No single person has assisted you. Mr. Fairley, or rather Mr. Tuson, sets up a theory that he has found two or three of the tail ends of grains of mouldy wheat—that was his extraordinary discovery. Professor Simonds, to do him justice, laughs at it because he says, “Why, if you fed cattle upon mouldy wheat, not merely two or three accidental grains, but in larger portions, I am not prepared to say that it would do them any mischief.” But talk about a few little mouldy grains; why, Gentlemen, the very cake upon which that gentleman had made his experiments was marked with wet, and the mere change of atmosphere might account for a few of those little mouldy grains which he says he saw. Are you to attach the slightest significance, or place the slightest confidence in these infinitesimal and hypercritical suggestions based on the discoveries which are revealed by the microscope? I venture to say, on the contrary, you will agree with me that they are calculated to teach you nothing; for what is the case of my client to-day may be the case with another manufacturer to-morrow. I do not care whether it is cloth or cake, or any other article of commerce, I say if a man is to have his character kept away by the intricacies and infinitesimals of the microscope against a body of evidence such as I have had the honour to submit to you, why then it will be a bad day indeed if they are not able to point to the solid strength of their case, as overriding all the subtleties of a nice and prying philosophy, such as has been brought to bear upon the examination of this cake. Before I part with this subject I must say I heard, with astonishment, one piece of evidence from the lips of Professor Fairley. It did seem to be a startling proposition, and it was one in which he was unsupported by anybody else: I ventured to put forward a suggestion before you, as to which he was silent in his Report in the first instance. But now at the trial, and when it is so important if one witness can be a little more ingenious than another, he actually suggests that this cake, of which a sample was before you here

yesterday, was never put through the rollers or under the crushers for the purpose of having the oil expressed from it at all; but that it was made, manipulated, and the various ingredients put together, and forced and crushed together for the purpose of making cake, to deceive the too trustful and confiding farmers of Yorkshire! And upon what did he base that theory? Why upon some absurd notion that the linseed in the cake that he saw ought to be horizontal, and was perpendicular. So that because he finds (or thinks he finds) a larger number of perpendicular than horizontal grains in the cake, this pseudo-philosopher and distinguished analyst, actually propounds a theory of the blackest character as against my client, one into which my friend does not follow him, one into which the learned professor does not follow him, because Mr. Simonds you know says, "I do not think they were purposely put in," but Mr. Fairley says boldly, "I say this cake was made for the purpose of prepared and premeditated deception, I say Mr. Kidd found it a profitable thing for him to employ his men and his resources to manufacture cake of that description, in order to palm it off upon the public through Mr. Ayre, and not as the result of the crushing of the seed for the legitimate purpose of expressing the oil, which is his ordinary trade. Gentlemen, I will venture to say you will be of opinion that you cannot accept such a theory as that; and, as I said just now, when you find such vague and wild theories, such loose suggestions, such dangerous topics thrown out for you to catch at, what conclusion are you to arrive at? Are you to assume when Science confesses that she cannot find a poison, that you must find it for her; that when Science says, I am modest, and although there is alleged to be something there that killed this cow, I cannot discover what it was—are you to find it out for her by some wild speculation or theory which is put forward for your acceptance, that it must have been caused by some deleterious product in the cake, when you have so much evidence on the other side distinctly meeting the suggestions which have been made?"

Now let us look at another point which my friend takes. He says, Well, there was nothing poisonous which could affect the nerves of the rumen of the cow itself or the cattle, still there was something there of an irritating kind, such as a pin or a needle, there was something in fact which ought not to be there, and which agglomerating together with the rest of the food produced death or disease amongst these cattle. But where is the evidence of anything of the sort? It is, after all, but the suggestion of a clever man. Of course the very cleverness of my friend and his witnesses enables them to deal in a variety of suggestions more or less plausible. Let Professor Simonds have the honour, if you please, of originating the suggestion that this cake operated upon the nerves of the rumen in such a manner as to produce a check to the peristaltic action of the rumen, and that leading to disorganization and degeneracy in the process of mastication by the animal gave rise to fermentation, and ultimately to the predominance of carbon in the blood, and so to death. Well, Professor Simonds may have and hold that theory, but recollect it is but theory, after all. It is but philosophy, after all—do not mistake it for fact—it is but an idea thrown out by a clever man. But then, Gentlemen, recollect also it is met by evidence on the other side. What say you to the positive evidence given to you here to-day? Observe my friend says he disputes that the 8 tons were made on the same day as the sample, and so on; but I am not going to occupy your time by a minute discussion as to the particular day of the week, or whether it was in the day shift or in the night shift when these things were made. This is what I maintain: that unless you have here a monstrous perjury on the part of the witnesses, unless you have men coming here to deceive and mislead you, you have it proved that in all this "Triangle Best" Linseed-cake sold to Messrs. Ayre there was a certain compound only used, and a certain care taken. Take

or instance, the man who was called before you here to-day—I did not attend calling him, I thought if I called Mr. Kidd and Mr. Stevenson, who give the orders and superintend the manufacture in the mill, I should have done enough; but my learned friend jumped up and said, there is a man who superintends up-stairs and takes care of the screening, Logdon, and Coggin who manages the sesamé; and so it became necessary for me to send for them both, and they have both been before you to-day. What was the effect of their testimony? Is it true what Logdon says? At all events my friend did not shake him in his cross-examination, and if it is true, what becomes of my friend's theory with reference to this cake having anything to do with the manufacture of ordinary cake? It is all very well for my friend to appeal to your prejudices on the side of the farmer. I do not appeal to any prejudices—I ask for justice on the side of the manufacturer, and simply say, Let the farmer have his rights, and let the manufacturer have his, but do not stop this seed-crushing altogether by rendering it impossible for a man to battle successfully with the load of prejudice that is heaped around him. My learned friend, in passing, said, "Look at this 'Triangle Plain,' I am perfectly astonished: I have actually heard it stated in open court that these manufacturers mix these foreign elements, previously screened from the pure seed, with it." Yes, they do—they admit it—and I do not deny it. Mr. Kidd told you that if he chose to hide it, he might have crushed it into a powder, and all the microscopes in the kingdom could not have found it out. But why should you assume these foreign matters are poisonous? They are vegetables; they, more or less, yield that out of which the substance and growth of animal life come; they do not contain all the oil or all the nitrogen of pure linseed, but that which is called the screenings of pure linseed is not poison, and is not rubbish; it is that for which the manufacturers have to pay; it is put away and is stored in bags, and is something which, after all, has in it some results which are useful, something which is productive in giving life and flesh, and aiding in the fattening and growth of animals. But, Gentlemen, we are not trying that question; it is not a question of what the materials of ordinary cake are. My friend throws it in in order that he may win upon your prejudices. I ask you to throw it out, because I appeal to your justice. Let us come to the question which is really in issue—the "Triangle Best" Linseed-cake, and see the precautions taken in reference to the manufacture of it. It is proved to you now by Mr. Kidd, by Mr. Stevenson, and by Coggin, that the system they adopt is a system by which it is simply impossible, unless the hand of Logdon opens the bag, or rather unless he allows the contents of the bag with his knowledge to be conveyed through the spout into the mill, it is impossible for this "Triangle Best" to be adulterated by putting the screenings into it. My friend said, "Have not you got a cupboard below-stairs into which these bags are put?" "I have." "Cannot anybody go in there and open them?" "Yes, they can; that is to say, a thief can go and do it." But when he is asked, "Can any person adulterate that which is being crushed?" he answers, "No, it must go up in the elevator before it comes down through the spout." Therefore, my friend was making a false suggestion to you, utterly forgetful of that which had been proved in the course of the case. Gentlemen, I venture to say that you will agree with this: that Mr. Kidd and his witnesses upon this point are utterly uncontradicted. What is he that you should regard his evidence with any doubt? He is a gentleman who has for years carried on this trade in Hull, and who at least, as far as his dealings with Mr. Ayre go, shows that Mr. Ayre knew exactly what he was buying. It is not the case of a manufacturer and broker, but the case of a manufacturer and merchant. Mr. Kidd makes 5s. per ton by the sale of this cake, Mr. Ayre makes 10s.; the profits of the one are no test of the profits of the other; their interests are entirely distinct;

and you must, therefore, in this case, take care that you do not in any way view this case as other than the case of Mr. Kidd, in which the question turns upon how far he is shown in the course of this inquiry to be unworthy your confidence and belief. I say, summing it up in one word, that unless Mr. Kidd, unless Mr. Stevenson, unless Mr. Logdon, have given you evidence which is wilfully false,—there is such care taken in that mill, such gathering together, such folding-up, such putting into bags and tying-up of these screenings, such keeping of them in a chamber below, and such a distinct manipulation of them afterwards, only giving them out for the purpose of mixing with the Ordinary cake, and always taking care to distinguish that from the “Triangle Best”—that if you are going to come to the conclusion that those bags of screenings were taken out, and emptied down that hopper, for the purpose of adulterating the ‘Triangle Best’ cake, which is the cake in question, in this case you will take a fearful leap in the dark, and without any solid basis supply that which is absolutely wanting in the case of my learned friend; and you will only supply it when you have trampled upon the character of the three witnesses, who have affirmatively sworn to that which my friend insinuates cannot possibly be true.

Well, Gentlemen, but that is not all. There were 8 tons of that cake given to these cowkeepers. Is there no value in that? Surely you will not say so? One of them, at least, gave a portion of that cake to each of his cattle, and it was not a matter of giving it them for one day or one feed, but day by day (in one case for a fortnight); these cowkeepers fed their cows, and they thrived upon it.

Now I will grant it might, perhaps, have been a more startling fact in my favour if we had got one of these cowkeepers to say he had given his animals 7 or 8 lbs. at one feed; but I do not know how that would have been, because, if these cows had not been accustomed to the food we might have killed them, and therefore it was not for Mr. Kidd to do that which he believes to have been the very cause of the fatal result in the case of Mr. Wells’s cattle. However, we do not interfere with the mode in which these cowkeepers give the cake to their cattle, we left it entirely to them; they give it in the proportions which you have heard, day by day, and the cattle were thriving very well. Ask yourselves the question, then, were these cattle fed on refuse, dirty linseed, deleterious cake, holding in its composition some inscrutable poison? I think I may anticipate your answer upon that point. But, Gentlemen, that is not all: my friend gives the thing the go-by; but you will not do so. There is a body of evidence to prove and establish beyond all doubt that this cake has been supplied for years from that very mill, and in this very month of February, in the quantities which you have heard; and with what result? Why, it has gone forth to the feeders of cattle from Northumberland to Warwickshire, and throughout England. Of the whole that was supplied in that month of February not a murmur of complaint from a single source has come; and of the 10,000 tons sold within the last few years not a single whisper of complaint has ever been uttered. Is this, then, a mere coincidence? Is this the “accident of an accident”? Are you to be asked in the absence of scientific discovery, on the mere theory of distinguished and clever men, that, because there may be a poison which they cannot detect, and of which this cow may have died, when you find that these thousands of tons, eaten without injury, trusted in and not complained of by farmers, sold broadcast throughout the country, to shut your ears to all these facts, in order that you may drink in a speculation founded on no fact, but merely upon theories of these distinguished men. Gentlemen, I put it to you warmly, still I ask you to deal with it logically, and will you not rather rely upon the affirmative evidence which I have submitted to you, as being something solid, in which you can place confidence as to the cause of the death and disease of these

animals, rather than upon that which is presented to you by my friend, which I venture to characterize as pure speculation and theory.

Now, with reference to that death and disease, let us see what is the evidence with which we have to deal. My friend says you are to shut out altogether the history of Airmyn Farm and Sancton. I am not going to shut them out. To my mind the history of what took place at these two farms is pregnant with grounds of observation in favour of Mr. Kidd, and against the theory of the Defendants. Take it that 6 or 7 lbs. produced the fatality and disease at Booth Ferry; but do not forget that, when you have another farm adjoining, you get the same cake administered to the cattle which are also being stall-fed. I am not going minutely to examine the order of the feeding, or the quantities in which it was supplied; but one thing is perfectly clear—the cattle at the second farm only got about 4 lbs; and that those cattle, although probably some of them certainly, as they will do at times, ate the cake more greedily than others, were cured without oil, or the application of the probang, by merely being turned out into the fields. They had no medicine to help them, but the course of nature followed, and they were well the next day. Now that is a fact which you will, I am sure, not forget when you are asked by and by by my Lord to estimate the force of the veterinary evidence which you have heard to-day. Then, with reference to the beasts at Booth Ferry, let me remind you of this—in each of the stalls there was one odd beast that had it worse than the others. I warrant you he was a fellow that had an extraordinarily good idea of getting his mouth full; he probably took more than his share, and therefore you will be of opinion, I think, that, in some degree, the intensity of the symptoms in those particular odd animals tends to strengthen the theory that it was over-feeding which produced the disease from which they suffered. But, then, my friend says I claim Sancton as an authority in my favour. Well, you know, Counsel are sometimes over-confident. I may be, and I cannot help thinking my friend was then; because what have you heard with regard to Sancton, where 3 lbs. only of the cake was given? You have no staring coat, no lolling of the tongue, no moaning or distress; so that even the critical eye of Mr. Wells, who, after all, you know is really an interested party here—the Plaintiff in another case more or less depending upon this, and whose evidence and its accuracy you must measure by that observation on my part—I say his interest would be, apart from higher considerations, to support that which he had communicated to the Agricultural Society—even he is not able to bring home the slightest trace of mischief to a single animal at Sancton, except the sheep. Well, what is the evidence with respect to the sheep? They had been fed on turnips and chopped straw (I do not know whether you know the habits of these animals); they are given this cake, and some of them prefer it with the chopped straw, and do not like to take it without; but, after a while, they take to the cake when it is mixed with chopped straw, and they eat it and like it, and not a sheep has suffered. Are you, therefore, not to come to the conclusion that the history of what took place at Sancton, and the use of this food there in a moderate and mild form, prepares you for the evidence that we have laid before you. You know it was admitted by Professor Simonds, and by my friend's witnesses generally, that there was not a symptom in life or *post-mortem* in the body of that cow or its viscera, which was not the same, symptom by symptom, as that which follows an ordinary attack of hoven or tympanitis. Recollect the moaning, the distress, the attitude of standing still, with the legs partly reared, the enormous gaseous distension—all these are now admitted to be the ordinary signs of a very ordinary complaint among cattle. Therefore certainly you have at least this fact to go upon in this case—that you have in the ordinary known walks of every-day experience, not in the pages of scientific experiment or conjecture, but in the result of practical life, from those

who trace it from having on many occasions attended the cattle, that it is one of the common causes of suffering attended with the same identical symptoms which this cow seems to have exhibited before she died. When they talked of blood-poisoning, one was anxious to know how they made that out. But it is explained afterwards that the blood-poisoning is merely the predominance of carbon in the blood, which prevents the oxygen and the carbon meeting together, and helping the course of digestion. You have, therefore, no doubt, chemical influences acting which produced that blackening and poisoning in the animals which is called blood-poisoning. But the same thing occurs always in tympanitis, from whatever cause that may have been produced. Therefore it is that I say you have in this case that which has made it clear to demonstration, that (unless you can be satisfied on some other theory which is set up) there is enough to account for all that you heard of by the suggestion that this was a case of ordinary tympanitis.

Then, what have you on the other side? You have on the part of my friend plenty of conjecture. He says I am theorizing: I say he is. I say on his side you have nothing but conjecture, nothing but an idea that because something may have been in the cake, which no human being has been able to see or discover, and as to which you must come to the conclusion that it was there before you can support their theory, that because something may have been there which, if it was poisonous, and was there to such an extent as to produce a sensible effect on the nerves of the rumen, might account for the symptoms, therefore that which may be, must be, and hence it was that which caused the fermentation and indigestion of which this cow died. Now, what have you on the other side? We have called before you a number of veterinary surgeons, beginning with Mr. Holmes, who for thirty years has occupied more or less important positions in his business. He was chosen (it shows at least that he was a man of education, intelligence, and knowledge) to be veterinary surgeon to the cavalry in India, and men chosen for so important a position as that of keeping the horses of our Indian cavalry in good health are not young men in their profession or unknown men, they are generally well-educated men, and men in whom people have confidence. Before he went out to India he was practising here, and since his return he has spent his life as a practical man in the duties of his profession. True, he has not written learned essays in agricultural reviews, he has delivered no beautiful treatise or lecture illustrated with handsome pictures and engravings like Professor Simonds; he has filled no philosopher's chair; he has drawn no rapturous plaudits from the students of the college, but he has done this—he has quietly pursued the practice of his profession and learned the valuable lessons of practical experience, and has given you that which I venture to say you will not disregard in considering your verdict in this case: he stakes his professional reputation, in the acquirement of which he has grown grey, upon this, that this cow died from tympanitis, and that that arose from the alteration of the food. It is all very well for my friend to speculate about the particular time which intervened. Gentlemen, when that food was given by these labouring men called here they kept no note about the time. They spoke of its being about this time and that time, but half an hour sooner or later might bring the time nearer to the opinion which Mr. Holmes gave; and I venture to say that, in justice to him and to Mr. Kidd, whose witness he is, you will consider yourselves bound to accept these statements of men who at the time had not their particular attention called to it, and which, after all, are given with a certain vagueness as to the particular and exact hours and minutes at which certain food was administered, with extreme caution. And for this reason, all the more that two or three of the witnesses my friend called admitted that the cake had been laid aside or that there had been no supply for ten days. One of them, indeed, got into the box, and very inaccurately, as I believe, said

only five days. It is perfectly clear from the letters that Mr. Wells had been out of cake for ten days; and if you find an inaccuracy of that sort on one part of the case, you will accept with a little caution that which relates to another. But if you believe the evidence of Mr. Holmes, and have any trust in his long experience, he gives you the reasons for which he arrives at that practical solution of this matter. And, Gentlemen, do not be disturbed or think less of his opinion because of the accident that twenty or thirty other cattle suffered similarly in a greater or less degree, because, recollect this—if you drive twenty cattle into a thick clover-field on a dewy morning, in the course of a short time they would be standing up distended exactly in the same way as you have heard described with reference to these cattle—blown out like so many animal bladders in a very short time. Therefore it is idle to say that, because twenty or thirty suffered, you are to take up the case of the Defendants rather than that of the Plaintiff. What I submit is this—they were all being stall-fed, they were all treated in the same way, they are all subject to the same influences, and they each took it to a greater or less extent, just according to the degree in which they more voraciously indulged their appetite. I venture to put to you this, that Mr. Holmes' evidence gives you a distinct practical solution of the mischief which occurred to these animals—there is an effect, there is a cause: he has explained it all to you: he has given you that which is not theory, but the result of a long life of practical experience. Mr. Freeman, Mr. Broughton, and five other gentlemen who were called, more or less, according to age and experience, confirming, and the result surely which I am entitled to contend for is this—that you have called here from Yorkshire, Leeds, and various places, these gentlemen professing the art of veterinary surgery, giving their evidence in a case which to-morrow will be published to all the farmers in this country and all England, who gave it therefore under the sanction that they will be held to the opinions they have uttered, and who, having heard this whole case, stake their professional reputation individually and collectively upon this united opinion, that the cow died and that these cattle suffered, from tympanitis, produced by an alteration more or less sudden of food acting specially quickly amongst Short-horned cattle of high breed, and still more so upon cattle who were at the time undergoing the process of stall-feeding.

Now, Gentlemen, I have, I hope, fulfilled what I promised. I might, if I were to take the opportunity which the occasion would allow me, address you at greater length; but you have watched this case throughout, and I am very anxious, before I resume my seat, that whatever be the result of this case I should be able to feel that I have made no appeal that was not made to your judgment. Because I do feel that this is specially a case of such immense importance to the interest I represent (and no doubt of considerable importance to those whom my friend represents) that I am sure you will exercise upon it the most careful and anxious and deliberate judgment before you give your verdict. I know not of what materials that jury is composed; for aught I know there may be more farmers than manufacturers, and more private gentlemen than either; but this I do know—whatever its component parts may be, I have not the slightest doubt it is "pure linseed" in its composition, and that it will in this case retire from that box with a determination not to find a verdict against me, unless satisfied upon the positive weight of testimony that the Defendants have made out their plea. It was open to the Defendants, of course, Gentlemen, to have taken another course if they thought proper here, instead of placing justification upon this record. My friend may fritter away or criticise the language of that libel as he pleases, but you cannot under-estimate its effects. It attributes the death of that cow, and the disease of these cattle to cake manufactured by Mr. Kidd; it charges him with supplying the materials for "another case of so-called poisoning;"

it recites the case of Mr. Eaton, and the opinion of a veterinary surgeon that an animal in his herd died by poison; it speaks of the cake in this instance as being, "like Mr. Eaton's, a very bad cake;" it winds up by suggesting that it is "composed of dirty linseed and of the sweepings of warehouses." I will only say upon that, that you have to sweep out of your minds the affirmative oaths of the witnesses which I have called before you can accept the conclusion that any one of those statements is proved.

Gentlemen, there is one thing they have left out which they ought to have put in, because whoever prepared that libel, or that Report, has left out this important item—in the original Report of Professor Voelcker, he added this very significant paragraph, after giving the result of his analysis and the discoveries he had made—a most emphatic proviso or protest, if I might call it so, against a too sudden determination—he said, "At the same time I am bound to add that I have discovered no trace of poison in this food." Why was it that all the black names, all the husks and all the sweepings that are suggested, are put in and forced into daylight, and paraded in this newspaper, and yet this passage which ought surely to have gone out with it, unless indeed some one was clipping and paring down this Report who was animated by that spirit which seemed to be afraid there would be unfair dealing on the part of Mr. Ayre if he was allowed to manipulate the eight tons; and unless sometimes the great name of the Agricultural Society is used by those who too rapidly and indiscreetly indulge a suspicion, and then find themselves committed to a charge. Gentlemen, I am bound to caution you in this case, and I am sure you will accept my caution with the sincerity with which I offer it, that whatever be the assumed dignity, utility, or importance of this great public body, you ought to recollect that it is not the body themselves that have given their own personal attention to this matter, either in reference to the chemical inquiry, or to the preparation of that libel. The libel appears in the beginning of March; the investigation and the interrogatories are commenced, as you have heard from the letters, on the 25th March. They first published the libel, and then called upon Mr. Wells to help them in making out the justification; and, Gentlemen, all I ask you to do is to be guarded in a case which is supported in that way. We all know that there is a disposition in the mind when you start a theory, and perhaps even from the very fact that there is novelty in it, to believe that, by giving the sanction of your verdict, you may do some possible good. I mean to say there is danger of such a thought arising in your minds; but I will venture to ask you to look at the solid and affirmative testimony in this case, to be guided by the evidence which we have given you, which is the result of long experience, and that whatever respect you may feel for any theory or speculation, however ingenious or clever you may think it, you will rather rest your verdict on the solid basis which, I venture to hope, you will be of opinion our case presents. I am entitled to make another observation upon this part of the case, and that is, that on those who assert that this was a dirty linseed, composed of the sweepings of warehouses and so-called poisonous materials, lies the responsibility of discharging the *onus* of proof. If the result of your inquiry should even be this, that you could not go the whole way with me, and come to the conclusion that I have satisfied you from the body of testimony I have given that the charge contained in this libel is untrue, and that the character of my client is vindicated in that respect, still, if the Defendants have not succeeded in satisfying you so as to outweigh the evidence we have given as to the truth of the charges contained in this libel, unless you are left in a position in which your minds are without any doubt that that justification is proved, I claim, as I am entitled to claim, an acquittal at your hands, which would amount to a verdict in my favour—an acquittal from the charges put upon that plea of justification, because I am sure my lord by and



by will not correct me when I say that when those upon whom the law puts the *onus* of supporting their plea of justification fail, when the two bodies of testimony are laid before a jury, in making out the plea, the Plaintiff is entitled to the verdict. I trust and I hope it will not be the mere solution of a doubt that will give me that verdict, but that your verdict will be cheerfully given when you recall all the facts and suggestions which have been laid before you in this case in favour of my client.

Looking to that event, Gentlemen, there remains a matter upon which it would be out of place almost for me to address you; because, when it comes to be a question of damages, a jury can best know how to approximate a just solution. We have proved beyond all doubt, you know, that my client has suffered in his trade. This was an article of commerce which brought him in a profit of 5s. per ton; he was doing a very large trade, and that has been prejudiced and diminished, as Mr. Kidd told you, I think by about 1700 tons already in the past year, and no doubt the wide circulation of these Reports must have tended to carry on that mischievous tendency. His profit of 5s. per ton upon that can be very easily calculated by you. You have therefore something to guide you in estimating the damages. If this had been a case of personal malice and spite you would do it by a very different measure, but it is not that. I never charged that, or asked for sympathy upon that ground. I only characterize it as the result of a hasty conclusion arrived at by those interested on the part of the Defendants.

Gentlemen, in conclusion, I do venture to trust and believe that truth and justice will vindicate my client's case at your hands, and that you will agree with me that my observations are entitled to the weight which I have ventured to ask you to attach to them. If you come to the conclusion that they are, you will give my client such damages as will set his character right, and vindicate him from such imputations as a charge of this kind, if unanswered, must inevitably cast upon him.

---

#### SUMMING-UP.

MR. JUSTICE BLACKBURN: In this case the action is brought for a libel, and two pleas are pleaded, one of Not Guilty, as to which it is now admitted that the libel was published by the Defendants, although they deny that there is a libel to the extent that is alleged. Under the plea of Not Guilty they would be entitled to deny the libel altogether; but it is not disputed now. But what they deny is, that it is a libel to the extent which the other side allege, and they have also pleaded that it is true in substance and effect.

Now, you know a libel has been defined (and I know no better definition of it) to be a publishing of something injurious to another without lawful excuse or justification; and the Royal Agricultural Society in the present case, though the very object of these Reports is, on their part, to warn the farmers against trading with people when they think they are not trading properly,—although that may be a very proper thing, and there is no malignity or immorality on their part, yet that would not be a

lawful excuse; and it is obvious that the more respectable the Society, the more likely would anything they published be to produce the evil effect on the person whom they denounced—depending upon the extent to which it goes. Consequently, there seems to be no doubt at all that what the Defendants have published would be a libel as far as it would be injurious to the Plaintiff, and the Plaintiff's manufacture of the oil-cake in respect of which he brings this action. Then the law stands also thus: that where a thing is true, though it still would remain a libel, a man can recover no damages for what is true; and therefore it may very well be that when there is a libel in which a man imputes, we will say, A, B, and C, the Defendant may be able to prove A and B to be true, but not C. In that case there would be a verdict for the Plaintiff, because the Defendant had not proved the whole of the libel to be true; but the damages which would be given would be only for that part that he does not prove to be true: and consequently there will be two things you will have to look at. The first is, to consider the libel, to see what are the imputations that are conveyed in what is in the 'Mark Lane Express,' published by the Defendants—how far do they go, what do they amount to, and what is the extent of the libel: this will be a question for you, and I will call your attention to it presently; then, secondly, when you come to consider the evidence which we have heard, what you think is the result of the proof as regards that? You see, it may be the Defendants have succeeded in proving all the allegations which are contained in the libel. If they have done that, if they have proved in substance everything that they have really stated, then the Defendants would have the verdict altogether; if they have proved only a portion of what they have stated, then they, leaving a portion of the libel unjustified and unexcused by not proving all the truth of it, the Plaintiff would be entitled to his verdict. But the amount of damages would depend entirely upon what you thought was the amount left unjustified and unexcused by not proving the truth of it, and the degree to which you think the Plaintiff would be entitled to damages for the injury done to him in respect of that. Now that I need not point out to you is a thing which varies excessively, according to the nature of the imputation.

Having first of all pointed that out to you, we will see what are the imputations contained in this libel—how far does it go? That is a question for you, and not for me; and when you have settled that question, namely, what is the extent to which this goes, we shall then be in a position to see whether the Defendant has succeeded in proving it all. Now, it begins in this way—"As usual at this season, cases of so-called poisoning from

the use of cakes have been brought under his (that is the chemist's) notice. The first to be mentioned is from Charles O. Eaton, Esq." I need not dwell further upon Mr. Eaton's case, because that is not in dispute here at all. Dr. Voelcker goes on to say this—"The cake (that is Mr. Eaton's cake) contained much earth-nut, also locust-meal, rice-dust, grass seeds, broken corn, and the usual small weed-seeds found in inferior or dirty linseed, and was altogether a bad linseed-cake." That sentence is alluded to again, when he begins to talk of Mr. Kidd's, the now Plaintiff's, linseed-cake afterwards, so that we must bear that in mind. Then it goes on (passing over the rest)—"Another case comes from John Wells, Esq., Feb. 18, a member of our Council, the whole of whose cattle were attacked with serious symptoms immediately after eating from a fresh purchase of cake, although only one case terminated fatally. This cake very much resembled the cake sold to Mr. Eaton." That is why I refer to it; he says that the cake sold to Mr. Eaton contained much earth-nut, husks, and so on, and altogether was a bad linseed-cake, and he says this cake very much resembled the cake sold to Mr. Eaton. That is, he clearly states it is an inferior linseed-cake—at the very least the imputation is that much. "Containing a quantity of cotton-cake."—When we have the evidence given in which the Defendants are endeavouring to justify it, the evidence comes to this, that there was in it some cotton-husks; whether this "cotton-cake" has been a misprint for "husks," or whether "husks" was put in without any justification at all, I do not know—I should think it was probably a slip in printing for "husks"—"rice, broken corn, and cocoanut, apparently made from dirty linseed, and the sweepings of corn-warehouses. A small sample of this cake had been sent before purchase to Mr. Wells, as best linseed-cake, price 10*l.* per ton, from Ayre, Brothers, Hull, the makers Messrs. Kidd, of Hull." That is the whole of the libel.

Now, how much do you think that does contain in it? One thing you will have to turn your mind to in that is this: I think it seems pretty plain that the Defendants, by publishing that, did state that this sample that they had examined was an inferior dirty cake; and in considering the libel, and seeing what it amounts to, you must put yourselves for the moment out of what you have heard to-day in Court altogether, and in the position of a farmer, or anybody else, who was reading this Report immediately after it came out—what impression would it produce on your mind reading it for the first time? Would it lead you to think that Messrs. Kidd's cake was made of an inferior dirty linseed, and had these weeds, &c., in it? I think certainly it would convey that impression; but then comes another part of

it, in which it will be a question for you to consider whether it does. It asserts that Mr. Wells's cattle, immediately after eating the cake, were seized with very bad symptoms, and no doubt that was the fact. What does that amount to—would you think that what they are asserting there amounts to this, that the cattle fell ill, and one of them died, owing to something that was a deleterious matter in the linseed or not? If you think it amounts to stating that Mr. Kidd manufactured and sold linseed-cake which contained deleterious matter, and so killed his cattle and made them ill, that is a serious imputation, and requires justification to a certain extent. If, on the other hand, you think that a man reading all this would only believe that it amounted to this, that the Plaintiff sold an inferior dirty linseed which was given to Mr. Wells's cattle, who immediately afterwards had bad symptoms; that would be true enough, because it is quite clear that there were bad symptoms, and Mr. Wells believed that they were occasioned by the linseed-cake. That is one of the things upon which you have had so much evidence given before you. The question is, whether that was the meaning of the libel at the time. Upon that you have to carry in your minds the question whether the justification is proved so as to go so far as to ascertain that the death of the cow and the illness of the cattle really followed from some deleterious ingredient contained in the linseed-cake.

Now one side has contended, and brought evidence before you to show, that the linseed-cake being given to the cattle in a feed of 7 lbs., when they had been some days without it, and 6 lbs. to the cows at the farm, and a smaller quantity,  $4\frac{1}{2}$  lbs., to the beasts that were at Airmyn Pastures, they all fell ill; the evidence being that the beasts that had the most seemed to fall ill most. I think both sides seem to be agreed upon that; and it is a thing that one would hardly doubt if any one were to go against it—that the fact of so many cattle, immediately after the giving of the linseed-cake, very much in proportion to the quantity of the linseed which was given to them, would lead to the conclusion that that illness was connected with the cattle having taken linseed-cake. But, then, the controversy upon that part of the matter—and it is the great one—is, does the fact that the cattle were all taken ill in this way satisfy you that there was some deleterious ingredient in this linseed-cake? There is another part of the evidence which I shall have to come to, as to the manufacture of the cake, which bears upon this; but still you will have to consider this. The Plaintiff's scientific Witnesses say this is the only case in which cattle have been affected; but then it is clear that the cows were all taken ill from something. I think the Defendant's Veterinary Surgeons also agree in this—

they do not always use the same terms when they agree, but they agree—that it was caused by something which the cattle took at the time which injured the working of the stomach—that which is known as the chewing of the cud—the rumen of the animals; and the consequence was that the food that was in the rumen, when it was no longer checked by the natural healthy working of the rumen, fermented and produced a great quantity of gas, and the distending gas “hove” the beasts, as they call it, and made them ill; and, in that particular case of the cow, the “hoven” went so far as not to produce absolute suffocation, but pressure on the lungs so as to produce death, not from suffocation, but from want of being able to breathe enough to keep the animal alive. That is what they say, and I think the Veterinary Surgeons on both sides agree that it was clear enough that there was something which they took which disagreed with the animals and produced that effect.

But then comes this: the Defendant says (and you will have to consider that) that 7 lbs. of linseed-cake, although the animals had been fasting from linseed in the one case for ten days, would not be sufficient, if it was good cake, to disorder the stomach so as to produce this illness; and, consequently, as all these animals took it, it must have been a thing which would make animals generally feel ill by taking it. He says in this particular parcel of cake there must have been something injurious and deleterious; and if he is bound to carry his justification so far as to say that the animal died of it, upon that he rests. On the other hand comes this consideration, which is strong against him—although they have had the cake, and the Royal Agricultural Society’s Chemists have had the means of getting everybody they could to look at it, they do not find anything they are able to trace as being absolutely poisonous; they do not find anything deleterious. But then they say, and they say truly, that chemical tests do not enable you to detect vegetable poisons very well. Still, if there was something that crept in or got into the cake that was absolutely deleterious, one would naturally expect that the Defendants would have been able to give some evidence to show the poison that was in it; and that is a thing which you must bear in mind, and give it its weight.

Then, the Plaintiff’s Veterinary Surgeons, besides, rely upon that, saying, “we are confident that there was sufficient cause, supposing it was ever such good cake; for, if you give animals cake when they are feeding upon other things, if you give them a change of food and cake, if they gorge it or eat it rapidly, or, even without that, the mere change from what they have been used to, may disorder their stomachs and cause them to be ill;” and they say, therefore, that the giving of 7 lbs. in the one case,

and 6 lbs. in the other, and  $4\frac{1}{2}$  lbs. in the other, was enough to account for the animals being unwell, although there was nothing deleterious in the cake at all. Well, the answer to that, and the strongest thing which struck me as against that, is that the animals all became disordered from this; and certainly the evidence does not seem to show that 7 lbs. was a very large dose to give, and Mr. Wells's men, men of experience, and who were in the habit of giving it, evidently did not think it was a very large dose. That is one of the matters for you to consider.

Well, there is another thing that will bear upon this part of the case. I mean whether the animals actually died from something deleterious in the cake; whether in this parcel of two tons there may have been something got in which would not get into the others; something accidental, such as a poison. Upon that you will observe that the Plaintiffs got the eight tons of cake, and they gave it to the cowkeepers, and no harm came from it; and the other five tons were eaten by the cattle—it is true it was in small quantities—without anything wrong happening, or the cattle suffering in any way. Another portion of five tons was given to the sheep, and the sheep seem to have indicated, by taking a portion of it into their mouths and then spitting it out, that there was some taste which they did not like in it. Further than that they do not go; and afterwards, when it was mixed with chopped matter, they ate it and were no worse. That goes far to show that neither these eight tons of cake nor the other five contained much that was poisonous; they might have contained something wrong, but certainly it would show that they were not deleterious in themselves. It would tend very much to show that. Then, further, we find that there has been a great deal of this kind of cake distributed; and it does not appear that anybody has said that they found anything wrong, or complained of it. And, further, it would show that the stuff which Mr. Kidd manufactured was not generally injurious to cattle, nor contained deleterious matters. That in this particular case Mr. Wells *bonâ fide* believed that these symptoms resulted from it, and so reported to the Society, is clear enough; and if all that you think would be understood in reading the libel over with regard to that was that this was a dirty, bad specimen of cake, and that immediately after it was administered there were these symptoms, that would be true. If you think it would be understood from it also—"Here was a dirty, bad specimen of seed," and we wish you to draw the inference that it actually did occasion cattle to be ill and one of them to die," why, then, that is proved or not proved according as you think it is really made out.

That is the first part; and then there comes the second part, in which I think there can be no doubt how far the libel goes.

They say this was an inferior bit of linseed-cake, dirty, and contained a quantity of seeds, of cotton-cake, rice, broken corn, and cocoa-nut, apparently made from dirty linseed and the sweepings of corn-warehouses. That is what they say there. There can be no doubt that that, coming from the Royal Agricultural Society, would be by itself a thing calculated to injure the sale of Mr. Kidd's property. But we have to see whether it is true, and, supposing it not to be true, there comes the question of damages. Now, upon both those questions this bears very much upon the evidence which we have got from Mr. Kidd. Mr. Kidd and Mr. Ayre both have been obliged to admit on interrogatories administered to them that, in the course of the manufacture, what you have had detailed before you here takes place. It seems that, some four years ago, Mr. Kidd and Mr. Ayre agreed together, as they say (this is their version of it), finding that linseed-cake made of linseed was very apt to have rape-seed in it, and, consequently to be bitter and bad, so that people complained of it, they got the idea into their heads that it would be a good thing to make a cake which would consist of screened linseed (which, of course, would be dear, being what they would call "Pure Linseed-cake," if it was made from that alone), with an admixture of a certain quantity of bran, so as to make it cheaper for them, and then to sell this compound so made of linseed and bran. At first they had only bran in it, but, after a time, sesamé-cake was taken and ground and mixed with it; and that was what they made this cake of—one-half only of linseed, and the other made of bran and sesamé-cake mixed with it.

Now, upon this part of the case, Mr. Seymour, in addressing you, used a phrase which I think expressed it very well. If in selling linseed-cake, you tell people that it is an honest product of your own, manufactured in pressing the oil out of the linseed, then it is obvious that this would not be that. If a man says, I will sell you linseed-cake pure, and he means by that, I have taken the linseed and have screened it, and I have squeezed out the oil and this is the honest manufacture with the oil squeezed out, that would be linseed-cake pure. If he says, I will give you linseed—I have not screened it, because as we all know, linseed comes with a certain quantity of impurities in it—I have not taken that out—I have squeezed out the oil and this is the product; there is not only linseed, but the impurities which were in it, because it was not screened linseed: if he says, it is the honest product of my manufacture when I have squeezed the oil out of any unscreened linseed that would be linseed-cake too, not so good as the other, but a good one, and I certainly have understood that generally speaking what is called pure linseed-cake, would be understood to be the honest product of manufactured screened

linseed, and that genuine linseed-cake would be that which was the honest product of the linseed, though the linseed had not been screened. There seems to be a third and inferior kind that they call "Ordinary;" what that is exactly, I do not know, I should myself say that a man who speaks of linseed-cake, though he may call it "Ordinary," would be bound to supply something which was principally composed of linseed: but that question does not arise so directly as the other. Now, you know Mr. Kidd tells us the mode in which they do it. It has been described, and no doubt you have attended to it thoroughly; it is this, they have the linseed, and, when they have got it there, they have to screen it; when they are going to make pure linseed-cake, there is first of all a rough screening which has only the effect of taking away the dirt, and we have nothing to do with that. Then when the linseed is put upstairs and they are going to make pure linseed-cake, they pass it through three screens and the effect of that is to separate nearly all the seeds. Out of that they squeeze the oil and make the pure cake of which I think there was no complaint whatever, and upon which there has been no imputation cast. Then there is this other thing: these screenings are put aside and I shall have to say a word presently to you upon that—there is this other kind of linseed-cake, which has been described. Looking back to Mr. Kidd's evidence, I see he does say that in making this "Triangle Best," they do screen it; he went on afterwards and said that the "Genuine" linseed-cake was not screened. That is what misled me in my recollection about that. He does say it was screened, but he only said screened once. The man called this morning, said when they were going to make it, they screened the linseed twice—I do not know that very much turns upon that; but when it has been passed down and passed into the hoppers and into the rollers and brought to the grinding-machine, they there put in for every 50 parts of linseed, 30 of this broken sesamé and 20 of bran—I think that is the proportion—and then they are mixed up together, and when they have been all mixed up together under the stones, and ground, they are then put into the kettles and so on, and the oil is squeezed out and the product which remains is not the product of the linseed which was used for the purpose of extracting the oil, but it is the product of the linseed with an equal bulk of those foreign ingredients which have been added to it. Now, it is quite true what was said, that any man has the right to make that manufacture and sell it, provided he sells it for what it is. If Mr. Kidd published to the world, "I make Kidd's Food for Cattle" (and he may tell them or not what it is made of), "and I say it is excellent stuff and I will sell it," that is all fair and proper; but if he has made this which is half linseed, with the intention, and for the



purpose of having it sold as linseed, so that the farmers and people who buy "Triangle Best" linseed are to be deluded into the belief that they are buying linseed-cake or the honest product of linseed when the oil has been pressed out, and are, instead of that, only buying 50 per cent. of it—why I think that is exceedingly wrong and so I should think would you. Then further, we find that these screenings are put aside and used in this way. In making the "Ordinary" linseed-cake, which does not come into this action except indirectly, if the linseed happens to be fine linseed, the plaintiff thinks it necessary,—not merely fair, not to give them the simple honest product of the linseed when the oil has been expressed—but he thinks it necessary for every 30 parts of the linseed which comes down to add 70 per cent. altogether, partly of ground earth-nut cakes which is an inferior thing to this sesamé as it would seem, and partly of bran as to which I forget the exact proportion. But a more curious and more important part of it is that if his linseed is good linseed, he thinks this inferior cake would not look genuine—I do not know what he thinks—it strikes one rather that he did it in order that people might not suspect—if it was clean linseed they might think it curious—but at all events for some reason or other, he thinks it necessary to adulterate his linseed by putting in the screenings which he took out of the other, and this makes the third class. He thinks it absolutely necessary to put in the screenings again and make that linseed dirty before he makes his cake from it. In that case the oil seems to be a subsidiary matter altogether, for there is only one-fourth of the linseed which gives the oil, because it would be an adulterated linseed by putting the screenings into it; and the other three parts are made up of earth-nut cake and bran, which are not oil-giving things. But again, as I said before, if he does that and lets people know what he does there is no harm. It is a trade a man has a right to carry on. But if he does it for the purpose and intent that they should be passed off on ignorant farmers as linseed, then it is a trade which would be a very wrong one indeed. Now, upon that part of the matter, there are two things which I think bear upon it, when you are looking at the evidence that has been given and the assertion on the part of the Defendant that this must have been very dirty and inferior linseed and had these sweepings from the warehouses in it that are spoken of. Is that true or not? On that the suggestion, and the only one I rather think, is this: there has been evidence given that there could not be these things in it, because in making their "Triangle Best" they always took care to have good linseed and also linseed twice screened and they never put the sweepings and screenings into that. The witnesses have been all here and they have been able

to show you how it was done. It would be a possible thing that the screenings intended for the "Ordinary" might by some accident get into this "Genuine," and if they had that would account for the thing looking much more dirty than it was before—but there is no evidence—none of the people who are called from Mr. Kidd's admit that such a thing could happen. Mr. Field could not possibly be expected to be prepared to follow every thing of that sort up; he could not suggest any way that it could happen. But doubtless, if a quantity of these screenings had got into this particular lot, it would account very much for its being very dirty and for a great deal, though I do not see how it would account for some things that are stated. That will be one of the questions for you to try—if supposing it is not proved—supposing the Defendants, the Agricultural Society, have unwarily said of this cake, "this cake was made of very dirty linseed" when in fact it was made from good, and having said it contained the sweepings of warehouses, when in point of fact there were none but it turned out that the cake was of that bad kind of manufacture that has been described that it was made for the purpose of delusion and not made an honest thing, and that they so made it, knowing that people would buy it as if it was linseed—I say it certainly seems to me that would not be a trade to be encouraged; and that in considering the damages, if you take that view, you would probably say if the Royal Agricultural Society have mistaken and said untruly this is made of dirty linseed, when in fact, if they had known all, they would have said, this is passed off as linseed and it contains 50 per cent. of other materials—if you take that view of it, it should affect the damages and cut them down very much indeed. That is a question entirely for you. It is in that way that I think it bears upon the damages.

The other question to which I wish to direct your attention is whether or not you think it is imputed to the Plaintiff that his cake actually poisoned the cattle from deleterious matters that were in it. If you think that is proved, then the damages would also be influenced by this. Still there would be damages—a verdict for the Plaintiffs upon both points; but if your view of the matter is that the Defendants have substantially proved from the whole result that the cattle did become ill because of some deleterious ingredient in the cake that was supplied, then there would be a verdict for the Defendant upon that; and if you think that you are satisfied on the evidence which the Defendant has given before you, consisting of people who looked at it and who tell you that they did see in it these quantities of things that they have mentioned although I think contained in very small portions, of cotton-husks, barley, seeds, and oats, and one thing and another—if you are satisfied from that that it is substantially

true that it really was dirty, and that the thing is substantially true, that again would be a verdict for the Defendant. But if you think that either of these have failed to be proved to the extent to which the libel goes and imputes them, then there will be a verdict for the Plaintiff with the damages that you think will be proper under the circumstances.

Now, Gentlemen, if you take that latter view it becomes of course very important to see whether this was really made to be sold as an imposition upon people who were to buy it, not knowing that one half of it was not linseed at all—was not the honest product of the seed after squeezing out the oil, from either clean or dirty linseed, but that it was an article which to the extent of one half was manufactured by putting in other things—very probably harmless in themselves and good enough at a certain price to sell, but which certainly would not be linseed—if you take that view, in considering the damages, that is a very important element to be considered.

As to that you have had a great deal of evidence and argument addressed to you, with reference to putting on the cake "Triangle Best," that not only was the triangle a trade mark, but the "best" was a trade mark also, and that it was meant to assert merely that this was Mr. Kidd's manufacture without asserting that it was good, better, or best. You must judge for yourselves upon that. Then it was asserted very boldly by Mr. Kidd and Mr. Ayre that they told everybody what it was. There was a total failure in that. When witnesses were called to-day, not one of them ventured to say they ever were told there was sesamé in it. They asserted that they told Mr. Wells about bran and sesamé being in it. But Mr. Wells swore that he never knew of the word "sesamé," except, as I said the other day, in the 'Arabian Nights,' till the action was begun. I am quite in ignorance whether you are farmers, landowners, merchants, or what, but some of you probably would know pretty well about this, whether it would be generally known that linseed-cake of this sort was made of sesamé in connection with the other ingredients. You must consider all about this—you find that in each document they always talk of it as "Triangle Best Linseed;" and in the circulars I certainly should not have considered that the "Triangle Best" which was written up there by being placed above the Ordinary, was an assertion that it was to be classed with the Ordinary. I should have supposed, from its price and the description, it was intended to be represented as linseed-cake but not the linseed-cake which was made pure—certainly not one which had a warranty, but still a linseed-cake. But after all it is more a matter of substance whether it was held forth in that way or not. There is some truth in Mr. Wells's assertion who said, when he heard of bran being mixed with it, that to pay

10*l.* for bran is rather expensive, because a man might buy hi linseed and he might buy bran and mix them up himself: and so with the sesamé-cake, if he knew it. It seems to be wort 6*l.* 5*s.* a ton, and when it is mixed up with the bran and sold for 10*l.* a ton, he might have bought that separately much more cheaply. That is an argument which would go to make you think that the farmers, and others buying it, would hardly be aware that they were buying cake with only one half of the proper stuff in it. That goes to affect not the verdict but the damages supposing you find a verdict for the Plaintiff.

Now, Gentlemen, as the case has lasted so long a time, and probably you are tired, I will not attempt to go through the evidence at all, unless there is any portion of it which you wish to read. If there is any portion of the evidence that you wish to have your memories refreshed upon, or any portion of the evidence that has struck some of you one way and some another and you want to hear my comments upon it, tell me, and I will read it; but, unless there is something of that sort, I will end as I began, by telling you first to ask yourselves—reading this ‘Mark Lane Express’—how would that strike you if you were reading it for the first time? How much injurious matter would it convey to your minds against Mr. Kidd? Consider that, and then say how much of that you think is justified and proved. If the substance, and all of that which you think would be conveyed to a man reading it for the first time, is shown to be true, that is a verdict for the Defendants. If no part of it is shown to be true, I need hardly say the damages ought to be high (subject to the other point I was putting), because it is quite true that its publication by the Royal Agricultural Society would clearly injure a man very seriously in the sale of an article like this. But, in measuring the damages, you must consider how much is shown to be true, and consider whether you think this kind of trade is an honest kind of trade, which you think a man ought to conduct, or whether you think it is a fraudulent trade, carried on for the purpose of deception, in which, though he is entitled to recover damages, because the Defendants have imputed something to him which was not true, yet there was this very serious and true imputation which only comes out afterwards. That would cut down the damages very much; I do not even say it might not cut them down to be purely nominal damages. Still, it would not prevent the Plaintiff getting a verdict.

All that you will consider for yourselves, and if there is any part of the case that you would like my advice upon, or any portion of the notes which you would like read, tell me, and I will do it; but, without that intimation from you, I will not trouble you any further.

The FOREMAN: My Lord, we should like to retire.

Mr. SEYMOUR: I do not know whether you would like to have copy of the 'Mark Lane Express.'

The FOREMAN: We have got one.

Mr. Justice BLACKBURN: Do you think there is any prospect of your wishing to ask me anything? I will willingly wait if you think so, but, if not, I will go away.

The FOREMAN: My Lord, one question with regard to the misrepresentation as was alleged upon Mr. Ayre's circulars. Mr. Kidd is the Plaintiff, and if we conclude that they are a misrepresentation, the question is, did that affect Mr. Kidd?

Mr. Justice BLACKBURN: Well, I will tell you how that will be. You are quite right to call my attention to it. Mr. Kidd himself is the manufacturer merely. If he sold to Ayre, and there was nothing more than a sale, he would be responsible for what he did himself, and not for what Mr. Ayre did; but, then, as I understand the evidence, and that is what you have to consider, whether it is so or not—as I understand from the evidence Mr. Kidd and Mr. Ayre agreed that this article should be made and sold, and supplied to Ayre exclusively by the Plaintiff, being made in this one particular way, and that Mr. Ayre should sell it. Still, that would not make Mr. Kidd responsible for all that Mr. Ayre did if you think Mr. Kidd was in ignorance. Then comes the question (which I do not think was asked directly of anybody), do you think that, for these four years, Messrs. Ayre could have been sending round these circulars without Mr. Kidd knowing of it, they living in the same town?

Mr. FIELD: And then there are those invoices which show that they did know.

Mr. Justice BLACKBURN: Is there any document of Mr. Kidd's own that has been put in evidence which will answer the question?

Mr. SEYMOUR: There is nothing of the kind; there is no circular of Mr. Kidd's.

Mr. Justice BLACKBURN: No, but if there is an invoice from Mr. Kidd in which he calls it "Pure Linseed-cake"?

Mr. FIELD: It was put in.

Mr. SEYMOUR: No, there is nothing of the kind.

Mr. Justice BLACKBURN: I do not remember where it was; how shall I be able to find it in this immense mass of notes?

Mr. SEYMOUR: There was only an assertion of documents which were not put in.

Mr. Justice BLACKBURN: Certainly documents must speak for themselves. Mr. Field thinks there is one, and the Jury is not to be swayed by that unless it is produced. I did not think there was one; and, if there was, it has escaped my attention.

Mr. FIELD: An order was put in for two tons of the best linseed-cake on Mr. Kidd; it was put in by Mr. Ayre.

Mr. Justice BLACKBURN: It is true there was an order, which I think Mr. Kidd sent direct; Mr. Kidd sent direct those two tons from his warehouse, and there was an order given to send them on to Mr. Wells; and I rather think that that order—

Mr. FIELD: Was an order for two tons of “Triangle Best Linseed” cake.

Mr. SEYMOUR: That was an order from Mr. Ayre.

Mr. Justice BLACKBURN: I know. That is true; there is that document, Gentlemen, which, besides the probability I was speaking of about his knowing—when Mr. Ayre sends to Mr. Kidd, saying, “Send two tons of your ‘Triangle Best’ to Mr. Wells:” he calls them “two tons of your Triangle Best Linseed”—that is the bearing of that. Then, Gentlemen, you think you probably will not require me, but I shall be found at the lodgings if you do send for me.

The FOREMAN: I think we shall, my Lord.

Mr. Justice BLACKBURN: Very well, I will wait a little to see whether there is anything you would like to ask.

[The Jury retired at 5·35 P.M.]

Mr. Justice BLACKBURN: Is there any suggestion if the Jury should not agree? Because it is very desirable to have a Verdict. I suppose the verdict in this case would determine some of the others, and the result of the Jury disagreeing would be that we should have to do all this over again.

Mr. FIELD: My learned friends are the actors in the next two cases.

[The Jury returned into Court at 10·30 P.M.]

The ASSOCIATE: Do you find for the Plaintiff or for the Defendant?

The FOREMAN: We find for the Plaintiff.

The ASSOCIATE: What damages do you find?

The FOREMAN: Ten guineas.

At the sitting of the Court on the following morning (the 10th) the following discussion and arrangement took place:—

Mr. SEYMOUR: Your Lordship will certify for a Special Jury?

Mr. Justice BLACKBURN: Certainly; it was a case for a Special Jury no doubt. What are we going to do now? we seem to be waiting. Do you go on with the next case of *Ayre v. The Royal Agricultural Society*, or not?

Mr. SEYMOUR: I am perfectly ready my Lord.

Mr. Justice BLACKBURN: Very well; call it on.

Mr. FIELD: I shall have to ask what my friend will do with reference to the remaining cases? There are three more cases in the list in reference to this matter,

Mr. Justice BLACKBURN : Yes.

Mr. FIELD : And what I should propose to do is that your Lordship, taking the verdict of the Jury, should deal between my friend and myself, and say what should be done with the three cases remaining.

Mr. Justice BLACKBURN : I cannot do anything with regard to the other two libel cases. Of course you know from my summing up what my view of the matter is. It will be for the parties to consider whether they will settle them. If you choose to go on now, the Plaintiff has a perfect right to do so ; or, you may settle them. The question is which you prefer—whether you will try the question again now, or wait till the next Assizes, when you may have a different Jury and a different Judge. But as to the case of *Wells v. Ayre*, the breach of contract case, there are a great many points of law arising upon that ; and it struck me that if Mr. Wells were not to insist upon the price of the cow, but was content simply to try the question of the price of the article, you might easily agree upon that and make a special case of it, leaving the Court to draw inferences. But as to the two libels I can say nothing about them ; but must leave it to the parties to settle amongst themselves.

[The learned Counsel consulted together.]

Mr. Justice BLACKBURN : I think perhaps the best plan would be to go on with No. 6, passing over these cases for the present, and then you will have a little more time to consult.

Mr. FIELD : My friend and I are both engaged in No. 6.

Mr. SEYMOUR : We are not losing time my Lord.

Mr. FIELD : We are making some progress.

Mr. Justice BLACKBURN : Oh, if you have a prospect of coming to terms, by all means do so.

Mr. SEYMOUR : My Lord, I have made my friend a proposition.

Mr. Justice BLACKBURN : Do you wish to settle it now ; or, as I said before, will you go on with the other cases and let this stand over till to-morrow, so that you may have a little more time ?

Mr. FIELD : Your Lordship sees all our witnesses are here, and we are very anxious to dispose of this at once, in order that they may all go away if possible.

Mr. Justice BLACKBURN : Then it is very desirable that you should do so.

[The parties again consulted.]

Mr. FIELD : I think my friend and I have agreed as to what is to be done. I am willing on the part of the 'Yorkshire Post' newspaper that a verdict in their case should be taken for 40s. with a certificate.

Mr. SEYMOUR : Your Lordship will certify for a Special Jury and costs ?

Mr. Justice BLACKBURN : The costs of the Special Jury you have not paid or incurred. However, you are willing to take a verdict for 40s. with a certificate for costs ?

Mr. SEYMOUR : Yes.

Mr. FIELD : Yes.

Mr. Justice BLACKBURN : If you are agreed upon that, I have no objection to that course.

Mr. SEYMOUR : Including any costs incurred in striking the Special Jury.

Mr. FIELD : With regard to the other two cases, Nos. 3 and 4, we will make them remanets till the next Assizes.

Mr. Justice BLACKBURN : Very well.

Mr. FIELD : With regard to No. 6, it is to be open to my friend and myself to agree upon the facts and turn it into a special case.

Mr. Justice BLACKBURN : You do not need leave for that ; that is open to you on either side. Very well, then ; there will be no objection to these two being made remanets.

Mr. SEYMOUR: Any costs incurred with regard to the Special Jury your Lordship will certify for in the 'Yorkshire Post' case?

Mr. Justice BLACKBURN: Are there any?

Mr. SEYMOUR: I believe so.

Mr. Justice BLACKBURN: Well, no doubt it is a proper case.

Mr. FIELD: I intended that, my Lord, no doubt.

Mr. Justice BLACKBURN: Very well; take your verdict, if you please, and as you please, with any certificates you want. I suppose if you swear the Special Jury and take their verdict, they must be paid.

Mr. FIELD: Will you withdraw the record?

Mr. SEYMOUR: Yes; we will take a Judge's order—we will consent to your Lordship's verdict.

Mr. Justice BLACKBURN: Withdraw the record on the terms mentioned.

Mr. SEYMOUR: We will take your Lordship's verdict by consent.

Mr. Justice BLACKBURN: Very well; be it so.

The ASSOCIATE: Is that in No. 3?

Mr. ROBERTS: No; that is in the case to which the Yorkshire Conservative News Association are Defendants.

Mr. Justice BLACKBURN: That is No. 33.

Mr. ROBERTS: We are to have all the certificates.

The ASSOCIATE: Then in both the other cases the records are withdrawn?

Mr. Justice BLACKBURN: I understand not withdrawn—made remanets.

Mr. FIELD: Made remanets.

The following Report, taken from the 'Yorkshire Post' of the 16th of August, shows the result of this action upon the trade:—

#### MEETING OF THE HULL LINSEED-CAKE TRADE.

A meeting of seed-crushers and cake-merchants of this town, at which four-fifths of the trade were present or represented, was held at the offices of the Chamber of Commerce, Bowlalley Lane, Hull, on Wednesday, Mr. Horatio Harriman Ayre (of the firm of Ayre, Brothers) being in the chair.

The CHAIRMAN opened the proceedings by reading the circular convening the meeting. He then referred to the recent actions for libel which had been tried at Leeds, and stated that the attention of his firm had been called to a very important point in a letter which they had received from their solicitor, Mr. F. F. Ayre. The letter was as follows:—

“Dear Sirs,—During the recent trial at Leeds of the action of *Kidd v. the Royal Agricultural Society of England* for libel, Mr. Justice Blackburn expressed a very decided opinion that to sell under the name of linseed-cake any cake not made entirely from linseed was to perpetrate a fraud. At the same trial Mr. John Wells, who appeared to have received regularly your trade circulars, and to have been treated by you as one of the trade, stated in his evidence that he believed that the cake sold to him as Triangle Best linseed-cake, notwithstanding the price sold at, and his knowledge of pure linseed-cakes and genuine linseed-



cakes, was a genuine linseed-cake, and not a mixed or compound one. I am aware that it is well established and known in the Hull cake-trade that the term linseed-cake, as used in the trade, does not, and is not intended to, describe merely cakes made of linseed, but that it comprises as well cakes made of the several admixtures used by the Hull seed-crushers. I am also aware that the words 'genuine linseed-cake' and 'pure linseed-cake' are the only two terms used by the trade as descriptive of cakes made of linseed without any admixture by the crusher, the former being made of linseed as imported with its natural impurities, and the latter, as far as practicable, without. So long as the term linseed-cake was used, as it originally was, to express mere *residuum* of the seed after the linseed oil had been expressed, it was comparatively of little importance what other ingredients the cake contained, but when the cake became an equally important article of commerce as the oil, as it now has, the term applied to such cake becomes a matter of importance, and I venture to suggest that the time has arrived when you, as large dealers of cake, may, and indeed, under the circumstances, ought to bring the whole matter, in conjunction with Mr. Kidd, if he will join you, and without him if he will not, before a meeting of the crushers and dealers for their information and deliberation, and if you agree with me, I would suggest that you bring forward a proposition that in future no cakes, other than those now known as genuine and pure linseed-cakes, shall be sold or described as linseed-cakes, and that all mixed or compound cakes shall be sold as such, and be known by the particular brands which each crusher may adopt.—Yours truly,  
(Signed) "F. F. AYRE."

The CHAIRMAN said that, after receiving this letter, his firm and Mr. Kidd issued circulars to the crushers and cake-dealers, calling special attention to the ruling of Mr. Justice Blackburn, as mentioned in the letter. Although his (the Chairman's) firm had sold the cakes mentioned in the trial to Mr. Wells as mixed cakes, and had bought them from Mr. Kidd, the crusher, as such, which was in perfect accord with the custom of the trade, yet Mr. Justice Blackburn ruled that the calling any cakes linseed-cakes except those made from linseed, either screened or as imported, was a commercial fraud, and therefore that any one selling composite-cakes as linseed-cakes would not be fulfilling his contract. Under these circumstances, he (the Chairman) considered it incumbent upon the cake-trade to at once place the matter on a proper footing, and to declare that in future the trade will not call any other cakes linseed-cakes except those already described as pure and genuine. He thought the present

a grand opportunity for completely removing the stigma which had so long hung over the trade, and which was so constantly and industriously circulated by several seed-crushers and cake-companies throughout the country. As good and as pure linseed-cakes were made in Hull as in any place, but from the fact that all kinds of cake were sold in Hull under the name of linseed-cakes, their opponents had taken advantage of it to draw comparisons between the pure cakes of the country mills, and the lower quality cakes of Hull to the disadvantage of the latter. The Chairman concluded by moving:—

That after this date, no other cakes than those now known as genuine linseed-cakes and pure linseed-cakes should be sold or described as linseed-cakes.

Mr. KIDD briefly seconded the resolution.

Mr. CHAMBERS (Chambers and Fergus) said he highly approved of the proposed alterations, but thought the resolution should be carried a step further. He moved as an amendment that the words linseed-cakes should be applied only to "Pure Linseed-cakes."

The amendment was seconded by Mr. R. V. KNOWLES.

The CHAIRMAN and seconder of the resolution declared themselves in favour of the amendment, which, on being put to the meeting, was carried unanimously.

The following resolutions were carried:—

"1. That from and after this date no other cakes than pure linseed-cakes shall be sold or described as 'linseed-cakes.'

"2. That all mixed or compound-cakes shall be described as such, and shall be known and sold by the particular brand which the crusher thereof now has, or hereafter may adopt.

"3. That the resolutions passed at this meeting be duly advertised in the 'Mark Lane Express,' 'Bell's Weekly Messenger,' 'The Magnet,' 'Yorkshire Post,' 'Leeds Mercury,' 'Stamford Mercury,' 'Birmingham Post,' 'Eastern Morning News,' and 'Hull News,' and such other papers as the committee to be appointed may select.

"4. That Messrs. John H. Walker, H. H. and A. S. Ayre, and H. W. Chambers be appointed a committee to advertise the resolutions brought forward at this meeting in the papers named, and in such others as they may select.

"5. That it is desirable that a Linseed-Cake Association for the protection of the trade should be formed; and that Messrs. F. Smith, J. Harrison, R. Reynalds, R. Blyth, H. H. Ayre, W. Gray, and J. H. Walker be appointed a committee, with power to add to their number, for the purpose of organizing such association, and reporting to a future meeting.

"6. That the trade of Hull is indebted to Messrs. Ayre, Brothers,

and to Mr. Samuel George Kidd, for the steps they have taken in the late legal proceedings for protecting the interests of the trade, and also for convening this meeting.

“7. That the thanks of this meeting be given to the Hull Chamber of Commerce for the use of their offices for this meeting.”

---

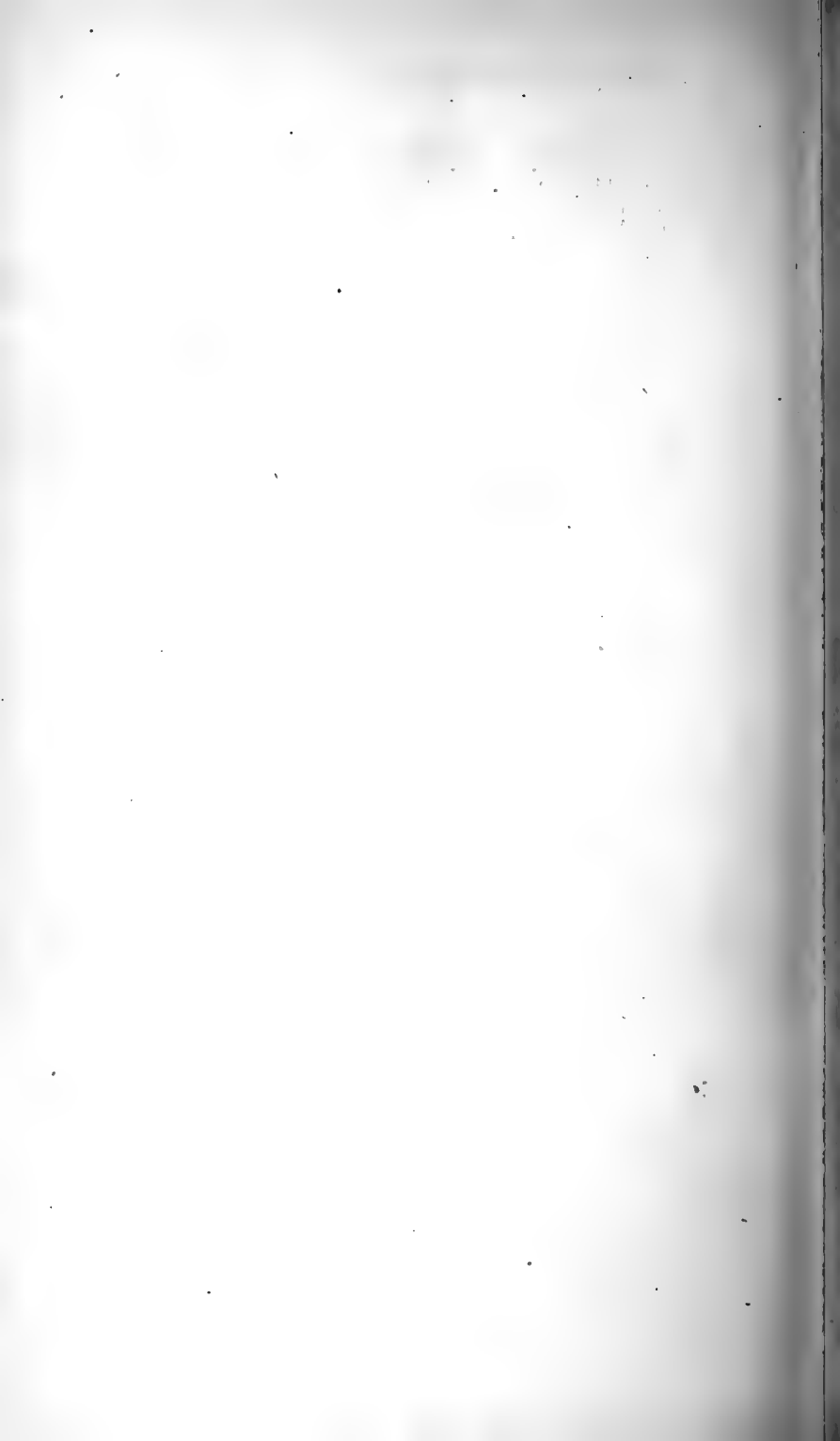

# Royal Agricultural Society of England.

1872.

## President.

SIR WATKIN W. WYNN, BART. M.P.

## Trustees.

Year when Elected.	
1857	BRIDPORT, Viscount, <i>Cumberland Lodge, Windsor, Berkshire.</i>
1839	CHALLONER, Colonel, <i>Portnall Park, Staines, Middlesex.</i>
1850	CHESHAM, Lord, <i>Latimer, Chesham, Bucks.</i>
1861	HOLLAND, EDWARD, <i>Dumbleton Hall, Evesham, Gloucestershire.</i>
1854	MACDONALD, SIR ARCHIBALD KEPPEL, Bt., <i>Woolmer Lodge, Liphook, Hants.</i>
1860	MARLBOROUGH, Duke of, K.G., <i>Blenheim Park, Oxford.</i>
1839	PORTMAN, Lord, <i>Bryanston, Blandford, Dorset.</i>
1856	POWIS, Earl of, <i>Powis Castle, Welshpool, Montgomeryshire.</i>
1858	RUTLAND, Duke of, K.G., <i>Belvoir Castle, Grantham, Leicestershire.</i>
1848	SPEAKER, The Rt. Hon. the, <i>Ossington, Newark-on-Trent, Notts.</i>
1839	THOMPSON, HARRY STEPHEN, <i>Kirby Hall, York.</i>
1839	TREDEGAR, Lord, <i>Tredegar Park, Newport, Monmouthshire.</i>

## Vice-Presidents.

1861	CATHCART, Earl, <i>Thornton-le-Street, Thirsk, Yorkshire.</i>
1839	CHICHESTER, Earl of, <i>Stanmer Park, Lewes, Sussex.</i>
1867	DEVONSHIRE, Duke of, K.G., <i>Holker Hall, Lancashire.</i>
1847	EGMONT, Earl of, <i>Cowdray Park, Petworth, Sussex.</i>
1847	EVERSLEY, Viscount, <i>Heckfield Place, Winchfield, Hants.</i>
1848	GIBBS, B. T. BRANDRETH, <i>Halfmoon Street, Piccadilly, London, W.</i>
1847	HILL, Viscount, <i>Hawkstone Park, Salop.</i>
1858	KERRISON, Sir EDWARD C., Bart., <i>Brome Hall, Scole, Suffolk.</i>
1839	MILES, Sir WILLIAM, Bart., <i>Leigh Court, Bristol, Somersetshire.</i>
1852	RICHMOND, Duke of, K.G., <i>Goodwood, Chichester, Sussex.</i>
1859	VERNON, Lord, <i>Sudbury Hall, Derby.</i>
1855	WYNN, Sir WATKIN WILLIAMS, Bt., M.P., <i>Wynnstay, Ruabon, Denbighshire.</i>

## Other Members of Council.

1855	ACLAND, Sir THOMAS DYKE, Bart., M.P., <i>Spydoncote, Exeter, Devonshire.</i>
1858	* AMOS, CHARLES EDWARDS, 5, <i>Cedars Road, Clapham Common, Surrey.</i>
1867	BALDWIN, JOHN, <i>Luddington, Stratford-on-Avon, Warwickshire.</i>
1848	BARNETT, CHARLES, <i>Stratton Park, Biggleswade, Bedfordshire.</i>
1853	* BARTHOOPP, NATHANIEL GEORGE, <i>Hacheston, Wickham Market, Suffolk.</i>
1868	* BOOTH, THOMAS CHRISTOPHER, <i>Warlaby, Northallerton, Yorkshire.</i>
1863	* BOWLY, EDWARD, <i>Siddington House, Cirencester, Gloucestershire.</i>
1861	CANTRELL, CHARLES S., <i>Riding Court, Datchet, Bucks.</i>
1865	* CLIVE, GEORGE, <i>Perrystone, Ross, Herefordshire.</i>
1866	* DAVIES, DAVID REYNOLDS, <i>High Legh Hall, Knutsford, Cheshire.</i>
1861	DENT, J. D., M.P., <i>Ribston Hall, Wetherby, Yorkshire.</i>

\* Those Members of Council whose names are prefixed by an asterisk retire in July, but are eligible for re-election in May next.

## List of Officers.

Year when Elected.	
1860	DRUCE, JOSEPH, <i>Eynsham, Oxford.</i>
1868	*EDMONDS, WILLIAM JOHN, <i>Southrope, Lechlade, Gloucestershire.</i>
1871	*EGERTON, HOR. WILBRAHAM, M.P., <i>Rostherne Manor, Knutsford, Cheshire.</i>
1869	*HESKETH, SIR THOMAS, Bart., M.P., <i>Rufford Hall, Ormskirk, Lancashire.</i>
1866	*HORNSBY, RICHARD, <i>Spittle Gate, Grantham, Lincolnshire.</i>
1854	*HOSKYNs, CHANDOS WREN, M.P., <i>Harewood, Ross, Herefordshire.</i>
1871	JONES, J. BOWEN, <i>Emsdon House, Shrewsbury, Salop.</i>
1867	*KESTEVEN, Lord, <i>Caswick, Stamford, Lincolnshire.</i>
1863	KINGSCOTE, Colonel, M.P., <i>Kingscote, Wootton-under-Edge, Gloucestershire.</i>
1848	*LAWES, JOHN BENNET, <i>Rothamsted, St. Albans, Herts.</i>
1869	LEEDS, ROBERT, <i>Wicken Farm, Castleacre, Brandon, Norfolk.</i>
1872	*LEICESTER, Earl of, <i>Holkham Hall, Wells, Norfolk.</i>
1868	*LICHFIELD, Earl of, <i>Slugborough, Staffordshire.</i>
1867	LIDDELL, HOR. HENRY GEORGE, M.P., <i>Ravensworth Castle, Durham.</i>
1865	LOPES, SIR MASSEY, Bart., M.P., <i>Maristow, Roborough, Devon.</i>
1871	McINTOSH, DAVID, <i>Havering Park, Romford, Essex.</i>
1871	*MASFEN, R. HANBURY, <i>Pendeford, Wolverhampton, Staffordshire.</i>
1846	MILWARD, RICHARD, <i>Thurgarton Priory, Southwell, Notts.</i>
1857	PAIN, THOMAS, <i>The Grove, Basingstoke, Hants.</i>
1861	*RANDELL, CHARLES, <i>Chadbury, Evesham, Worcestershire.</i>
1868	RANSOME, ROBERT CHARLES, <i>Ipswich, Suffolk.</i>
1871	*RAWLENCE, JAMES, <i>Bulbridge, Wilton, Salisbury, Wilts.</i>
1869	RIDLEY, M. WHITE, M.P., <i>Blagdon, Crumlington, Northumberland.</i>
1862	RIGDEN, WILLIAM, <i>Hove, Brighton, Sussex.</i>
1861	*SANDAY, WILLIAM, <i>Radcliffe-on-Trent, Notts.</i>
1856	*SHUTTLEWORTH, JOSEPH, <i>Hartsholme Hall, Lincoln.</i>
1869	*STATTER, THOMAS, <i>Stand Hill, Whitefield, Manchester, Lancashire.</i>
1867	STONE, N. CHAMBERLAIN, <i>Aylestone Hall, Leicester.</i>
1857	TORR, WILLIAM, <i>Aylesby Manor, Great Grimsby, Lincolnshire.</i>
1845	TURNER, GEORGE, <i>Brampford Speke, Exeter, Devonshire.</i>
1871	TURNER, JABEZ, <i>Haddon, Huntingdonshire.</i>
1871	WAKEFIELD, WILLIAM H., <i>Kendal, Westmoreland.</i>
1867	WEBB, JAMES, <i>Spring Hill, Fladbury, Pershore, Worcestershire.</i>
1870	*WELBY, WILLIAM EARLE, M.P., <i>Newton House, Folkingham, Lincolnshire.</i>
1871	*WELLS, JOHN, <i>Booth Ferry, Howden, Yorkshire.</i>
1861	*WELLS, WILLIAM, M.P., <i>Holmewood, Peterborough, Northamptonshire.</i>
1870	WHITEHEAD, CHARLES, <i>Barming House, Maidstone, Kent.</i>
1866	WILSON, Lieut.-Colonel FULLER MATTLAND, <i>Stowlangtoft Hall, Bury St. Edmund's, Suffolk.</i>
1865	WILSON, JACOB, <i>Woodhorn Manor, Morpeth, Northumberland.</i>

## Secretary and Editor.

H. M. JENKINS, 12, *Hanover Square, London, W.*

*Consulting Chemist*—DR. AUGUSTUS VOELCKER, F.R.S., 11, *Salisbury Square, E.C.*  
*Consulting Botanist*—W. CARRUTHERS, F.R.S., F.L.S., *British Museum, W.C.*  
*Veterinary Inspector*—JAMES BEART SIMONDS, *Royal Veterinary College, N.W.*  
*Consulting Engineers*—EASTONS & ANDERSON, *The Grove, Southwark Street, S.E.*  
*Seedsmen*—THOMAS GIBBS and Co., *Corner of Halfmoon Street, Piccadilly, W.*  
*Publisher*—JOHN MURRAY, 50, *Albemarle Street, W.*  
*Bankers*—THE LONDON AND WESTMINSTER BANK, *St. James's Square Branch, S.W.*

\* Those Members of Council whose names are prefixed by an asterisk retire in July, but are eligible for re-election in May next.

## STANDING COMMITTEES FOR 1872.

### Finance Committee.

BRIDPORT, Viscount, Chairman.  
DAVIES, D. R.  
KINGSCOTE, Colonel, M.P.

RANDELL, CHARLES.  
TORR, WILLIAM.

### House Committee.

THE PRESIDENT.  
CHAIRMAN of Finance Committee.  
CHALLONER, Colonel.

KINGSCOTE, Colonel, M.P.  
GIBBS, B. T. BRANDRETH.  
TORR, WILLIAM.

### Journal Committee.

THOMPSON, H. S., Chairman.  
SPEAKER, The Rt. Hon. the  
ACLAND, Sir T. DYKE, Bart., M.P.  
DENT, J. D., M.P.  
HOLLAND, EDWARD.  
HOSKYNs, C. WREN, M.P.

MILWARD, RICHARD.  
RIDLEY, M. WHITE, M.P.  
WELBY, W. E., M.P.  
WELLS, W., M.P.  
WHITEHEAD, CHARLES.  
WILSON, JACOB.

### Chemical Committee.

WELLS, WILLIAM, M.P., Chairman.  
LICHFIELD, Lord.  
VERNON, Lord.  
DAVIES, D. R.  
DENT, J. D., M.P.  
EDMONDS, W. J.  
HOLLAND, EDWARD.

HOSKYNs, C. WREN, M.P.  
LAWES, J. B.  
VOELCKER, Dr. A.  
WAKEFIELD, W. H.  
WELBY, W. E., M.P.  
WHITEHEAD, CHARLES.  
WILSON, JACOB.

### Botanical Committee.

VERNON, Lord.  
DENT, J. D., M.P.  
EDMONDS, W. J.  
GIBBS, B. T. BRANDRETH.  
JONES, J. BOWEN.  
THOMPSON, H. S.

TURNER, JABEZ.  
VOELCKER, Dr.  
WELBY, W. E., M.P.  
WELLS, W., M.P.  
WHITEHEAD, CHARLES.

### Veterinary Committee.

BRIDPORT, Viscount (Chairman).  
DENT, J. D., M.P.  
GIBBS, B. T. BRANDRETH.  
LEEDS, ROBERT.  
RIDLEY, M. WHITE, M.P.  
SIMONDS, Professor.

STATTER, THOMAS.  
THOMPSON, H. S.  
VARNELL, Professor.  
WELLS, JOHN.  
WELLS, WILLIAM, M.P.  
WILSON, JACOB.

### Stock-Prizes Committee.

MILWARD, RICHARD (Chairman).  
BRIDPORT, Viscount.  
BALDWIN, JOHN.  
BARTHOLOPE, NATHANIEL G.  
BOOTH, T. C.  
BOWLY, EDWARD.  
DAVIES, D. R.  
DENT, J. D., M.P.  
DRUCE, JOSEPH.  
GIBBS, B. T. BRANDRETH.

LEEDS, ROBERT.  
MASFEN, R. H.  
RANDELL, CHAS.  
RIGDEN, WM.  
SANDAY, WM.  
TORR, WILLIAM.  
TURNER, GEORGE.  
WELLS, JOHN.  
WILSON, JACOB.  
The Stewards of Live Stock.

**Implement Committee.**

CHALLONER, Colonel (Chairman).	GIBBS, B. T. BRANDRETH.	SHUTTLEWORTH, JOSEPH.
BRIDPORT, Viscount.	HOLLAND, E.	THOMPSON, H. S.
VERNON, Lord.	HORNSBY, RICHARD.	TORR, WILLIAM.
MACDONALD, Sir A. K., Bart.	HOSKYN, C. WREN, M.P.	WELBY, W. EARLE, M.P.
AMOS, C. E.	LEEDS, ROBERT.	WELLS, JOHN.
BOOTH, T. C.	MASFEN, R. H.	WHITEHEAD, CHARLES.
CANTRELL, CHAS. S.	RANDELL, CHARLES.	WILSON, JACOB.
DRUCE, JOSEPH.	RANSOME, R. C.	The Stewards of Imple- ments.
EDMONDS, W. J.	SANDAY, WILLIAM.	

**General Cardiff Committee.**

VERNON, Lord (Chairman).	BARNETT, C.	MILWARD, RICHARD.
LICHFIELD, Earl of.	BOOTH, T. C.	RANDELL, CHARLES.
POWIS, Earl of.	BOWLY, EDWARD.	RANSOME, R. C.
BRIDPORT, Viscount.	CANTRELL, CHARLES S.	RIDLEY, M. W., M.P.
CHESHAM, Lord.	CARDIFF, Mayor of.	SANDAY, WILLIAM.
KESTEVEN, Lord.	CORBETT, J. S.	SHUTTLEWORTH, JOSEPH.
TREDEGAR, Lord.	DAVIES, D. R.	TORR, WILLIAM.
LOPES, Sir MASSEY, Bart., M.P.	DRUCE, JOSEPH.	TURBERVILL, Major.
MACDONALD, Sir A. K., Bart.	EDMONDS, W. J.	WEBB, JAMES.
WYNN, SIR WATKIN W., Bart., M.P.	GIBBS, B. T. BRANDRETH.	WELLS, WILLIAM, M.P.
ALEXANDER, W.	HORNSBY, RICHARD.	WHITEHEAD, CHARLES.
AMOS, C. E.	HOSKYN, C. WREN, M.P.	WILLIAMS, G. C.
	KINGSCOTE, Col., M.P.	WILSON, Lieut.-Col.
	LEEDS, ROBERT.	WILSON, JACOB.
	MASFEN, R. H.	The STEWARDS.

**Show-Bard Contracts Committee.**

RANDELL, CHARLES, Chairman.	HORNSBY, RICHARD.
BRIDPORT, Viscount.	MILWARD, RICHARD.
VERNON, Lord.	SHUTTLEWORTH, JOSEPH.
AMOS, C. E.	TORR, WILLIAM.
BOOTH, T. C.	WELLS, JOHN.
GIBBS, B. T. BRANDRETH.	

**Committee of Selection.**

THOMPSON, H. S. (Chairman).	KINGSCOTE, Colonel, M.P.
BRIDPORT, Viscount.	MILWARD, R.
DAVIES, D. R.	RANDELL, CHARLES.
DENT, J. D., M.P.	TORR, WILLIAM.
GIBBS, B. T. BRANDRETH.	WELLS, WILLIAM, M.P.
HOLLAND, E.	

And the Chairmen of the Standing Committees.

**Education Committee.**

HOLLAND, E., Chairman.	KINGSCOTE, Colonel, M.P.
LICHFIELD, Earl of.	RANSOME, R. C.
POWIS, Earl of.	WELLS, WILLIAM, M.P.
ACLAND, Sir T. DYKE, Bart., M.P.	VOELCKER, Dr.
DENT, J. D., M.P.	WHITEHEAD, CHARLES.
JONES, J. BOWEN.	

**Cattle Plague Committee.**

THE WHOLE COUNCIL.

\*\* The PRESIDENT, TRUSTEES, and VICE-PRESIDENTS are Members *ex officio* of all Committees.



## Royal Agricultural Society of England.

---

### GENERAL MEETING,

12, HANOVER SQUARE, THURSDAY, DECEMBER 7, 1871.

---

#### REPORT OF THE COUNCIL.

THE Council of the Royal Agricultural Society of England in presenting their half-yearly Report, have to state that since the last General Meeting in May, 6 Governors and 53 Members have died, and the names of 33 Members have been removed from the list; on the other hand, 1 Governor and 252 Members have been elected, so that the Society now consists of

69 Life Governors,  
72 Annual Governors,  
1622 Life Members,  
4030 Annual Members,  
14 Honorary Members,

making a total of 5807, showing an increase of 198 Members during the year 1871.

During the past half-year the Council has lost some of the oldest of its members, the ranks of the Trustees having been thinned by the death of Sir Thomas Dyke Acland and Lord Berners; the list of Vice-Presidents by the decease of Mr. Samuel Jonas; and the general body of the Council by the death of Mr. John Clayden. These vacancies have been filled up by the following elections:—Mr. E. Holland as a Trustee, in the place of Lord Berners; Sir A. K. Macdonald, Bart., as a Trustee in the room of Sir Thomas Dyke Acland, Bart., and Mr. B. T. Brandreth Gibbs as a Vice-President, in the room of Mr. Samuel Jonas. Mr. M'Intosh, of Havering Park, Essex, has been elected to fill the vacancy in the Council caused by the death of Mr. John Clayden, and the vacancies caused by the previous elections have been filled by the election of the

Hon. Wilbraham Egerton, M.P., of Rostherne Manor, Knutsford, and Mr. James Rawlence, of Bulbridge, Wilton, Salisbury.

The half-yearly statement of accounts to the 30th June, 1870, has been examined and approved by the Society's auditors and accountants, and has been published for the information of the members in the last number of the *Journal*. The permanent funded capital of the Society remains the same as at the last half-yearly meeting, namely 20,000*l.* New Three per Cents., but the Reserve Show-fund has been reduced by the sum of 500*l.*, and therefore now stands at 4112*l.* 7*s.* 8*d.*

The financial results of the Country Meetings at Oxford and Wolverhampton having been a loss to the Society of about 4000*l.*, owing chiefly to the extensive and costly nature of the trials of Implements, the Council have appointed a Special Committee to consider the whole question of the receipts and expenditure of the Society, and the possibility of securing equal results at less cost.

The extensive nature of these trials also presses with great severity on the Local Committees in years when land has specially to be hired for the purpose. The Council have therefore resolved that when the trials of Implements at the Country Meetings are not held in the Show-yard, one-half of the expense of providing trial-fields shall in future years be borne by the Society; but to enable the Council to know the extent of its engagements it has been stipulated that the competing localities shall state the maximum cost of the land required for the Trial of Implements, the acreage wanted being furnished by the Society.

The Wolverhampton Meeting was distinguished from previous exhibitions of the Society by the extensive trials of Steam-cultivating Machinery and Traction-engines, full reports on which have been furnished to the Members in the last number of the *Journal*. Notwithstanding a long continuance of unfavourable weather, the Council are able to congratulate the Society on the practical results of these trials. They have pointed out to the agricultural communities the best combinations of machinery for the cultivation of the land by Steam-power, not only by the medium of the most powerful sets of tackle; but also by means of less expensive machinery within the reach of individual farmers in districts where no system of hiring is in force. The competition for Lord Vernon's Prize Cup,

ffered for a set of machinery not to exceed 700*l.* in cost, and that for the Society's Prizes for sets of tackle in which the weight of the engine was restricted, as well as for others to be driven by ordinary portable engines, produced results which will be practically useful to farmers of every class who may be desirous of cultivating their land by the aid of steam.

The trials of Traction-engines were an entirely new feature, and the exhaustive report of the Engineer Judges has placed on permanent record the valuable additions which they made to our knowledge of the principles of Steam-traction on common roads, and the inferences which they suggest to the practical engineer.

The competition for the Prizes offered in the section of Hop-machinery was not so extensive as the Council had hoped to excite, but this disappointment has been to a great extent overcome by the fact that the trials exposed to exhibitors and other implement makers many striking defects in the existing machines.

The exhibition of Live Stock did not in some cases equal that of last year, but the show of Shropshire Sheep was the largest that has ever been held under the auspices of this Society. The liberality of the Local Committee in offering Prizes for numerous additional classes of Horses did not meet with an encouraging response from exhibitors, but it is to be feared that the charges for conveyance by the railway companies have a very prejudicial effect on this department of the Society's Show. Although the Council have frequently endeavoured unsuccessfully to obtain concessions from the railway companies for the conveyance of Live Stock, and more especially of Horses, they have recently placed themselves once more in communication with the railway authorities with this object in view.

The Farm-prize Competition in connection with the Wolverhampton Meeting excited great interest in the counties of Shropshire and Staffordshire, as well as in other parts of the kingdom. A full report on the successful farms, written by Mr. Wheatley, one of the Judges, has been published in the Society's *Journal*, and it is hoped that it may aid in producing results commensurate with the liberality of the landowners in the two counties in offering the first Prizes, the enterprise of the competing tenant-farmers, and the careful investigation of Mr. Wheatley and his colleagues.

The series of Farm-prize Competitions will be continued next

year, a Silver Cup, value 100*l.*, having been offered by the President of the Society (Sir Watkin W. Wynn, Bart., M.P.), and a second prize of 50*l.* by the Council. These prizes will be awarded to the two best managed farms in South Wales and Monmouthshire which shall conform to the following conditions :—

1. That they are not less than 100 acres in extent; 2. That not less than one-fourth of the land (not including sheepwalk) is under tillage; 3. That they are held (*a*) by a tenant-farmer paying a *bonâ-fide* rent for not less than three-fourths of the land in his occupation, or (*b*) by a landowner occupying his own farm, the total extent of whose property in agricultural land (exclusive of sheepwalk) does not exceed 200 acres, and whose sole business is farming.

The Implement Prize-sheet for the ensuing Country Meeting to be held at Cardiff has received the careful attention of the Council; and Prizes have been offered for Portable Steam-engines, Threshing Machines, Straw and Hay Elevators, Corn Screens, Corn Dressing Machines, and Seed Drawers. The regulations of the trials and the instructions to the Judges have been revised, especially in reference to the points representing perfection in Threshing Machines; and further restrictions have been imposed on exhibitors with a view of keeping the exhibition of implements within moderate limits.

The regulations affecting the awards of Medals to Miscellaneous Articles have also been once more under the consideration of the Council, and such modifications of them have been introduced into the Cardiff Prize-sheet as will ensure that the Medals are awarded either to implements belonging to the classes to be tried at that meeting, or to those which have an entirely novel construction and which are not included in the Society's classification.

The Council have renewed the Education Grant for the year 1872, on the same conditions as were attached to the examinations this year, feeling that more time must elapse before the advantages arising from success at these examinations can be generally appreciated.

Since the commencement of the publication of the Quarterly Reports of the Consulting Chemist, the number of analyses made by Professor Voelcker have increased during 1871 by 150 in excess of those made in 1870, and 265 over those of 1869; and the Council are satisfied that the publication of these quarterly reports has caused agriculturists more to appreciate the value of

chemical research, and has aroused a spirit of inquiry in this department of agriculture, which cannot fail to produce very satisfactory results. They trust therefore that the continuation of the publication of these reports of the Consulting Chemist may not be less advantageous to the members of the Society than they have hitherto been.

The Council have to announce that they have appointed Mr. W. Carruthers, F.R.S., Chief of the National Botanical Collection at the British Museum, to be the Consulting Botanist to the Society. In making this appointment the Council have endeavoured to secure the services of a competent Botanist, whose duty it will be to examine plants, seeds, &c., for the members of the Society; to report on the principal work performed by him during each year; and from time to time to furnish papers to the *Journal* on special subjects of botanical interest. The following schedule of charges has been provisionally fixed by the Council for the examination of plants and seeds for the use of members of the Society:—

No.		
1.—	A general opinion as to the genuineness and age of a sample of clover-seed (each sample) .. .. .	5s.
2.—	A detailed examination of a sample of dirty or impure clover-seed, with a report on its admixture with seeds of dodder or other weeds (each sample) .. .. .	10s.
3.—	A test examination of turnip or other cruciferous seed, with a report on its germinating power, or its adulteration with 000 seed (each sample) .. .. .	10s.
4.—	A test examination of any other kind of seed or corn, with a report on its germinating power (each sample) .. .. .	10s.
5.—	Determination of the species of any indigenous British plant (not parasitic) with a report on its habits (each species) .. .. .	5s.
6.—	Determination of the species of any epiphyte or vegetable parasite, on any farm-crop grown by the Member, with a report on its habits, and suggestions (where possible) as to its extermination or prevention (each species) .. .. .	10s.
7.—	Report on any other form of plant disease not caused by insects .. .. .	10s.
8.—	Determination of the species of a collection of natural grasses indigenous to any district on one kind of soil (each collection) .. .. .	10s.

The prevalence of Foot and Mouth Disease in English herds has induced the Council, on more than one occasion during the past half-year, to draw the attention of the Government to the existing regulations in reference to the importation of both Foreign and Irish Cattle, and to the restrictions which it is desirable to impose in order to diminish the risk of their conveying con-

tagious or infectious diseases to English stock. The correspondence between the Veterinary Department of the Privy Council and the Secretary of the Society, together with a *précis* of the various acts and orders in Council relating to the importation of foreign animals, has been published in the last number of the *Journal*; and, with regard to Irish stock, the Council have received the assurance of the Government that measures are being taken which, it is hoped, will be found satisfactory.

The existence amongst lambs of a wide-spread disease of home origin, has been brought under the notice of the Council by the Lincolnshire Agricultural Society during the past half-year. The nature and origin of this disease have been previously described in the *Journal* of the Society, but in view of the great losses which it has this year caused to Lincolnshire flock-masters, the Council have requested Professor Simonds to make a thorough and immediate examination of the nature of the disease and the circumstances under which it most commonly occurs, and to give suggestions for its treatment and prevention.

The relations between the Royal Veterinary College and the Society are still under discussion by the governing bodies of the two institutions; but the Council are hopeful that the result will be to extend the usefulness of the Veterinary Department of the Society in accordance with its increasing importance to the English agriculturist. In consequence of the death of Professor Spooner, the post of Principal of the Royal Veterinary College is now vacant; and it is possible that alterations may be made in the staff and course of study at the College. Under these circumstances the Council have postponed its decision on the relations of the Society to the College.

By Order of the Council,

H. M. JENKINS,

Secretary.

## MEMORANDA.

**ADDRESS OF LETTERS.**—The Society's office being situated in the postal district designated by the letter W, members, in their correspondence with the Secretary, are requested to subjoin that letter to the usual address.

**GENERAL MEETING** in London, in December, 1872.

**GENERAL MEETING** in London, May 22, 1873, at 12 o'clock.

**MEETING** at Cardiff, July 15th and four following days, 1872.

**MONTHLY COUNCIL** (for transaction of business), at 12 o'clock on the first Wednesday in every month, excepting January, September, and October: open only to Members of Council and Governors of the Society.

**ADJOURNMENTS.**—The Council adjourn over Passion and Easter weeks, when those weeks do not include the first Wednesday of the month; from the first Wednesday in August to the first Wednesday in November; and from the first Wednesday in December to the first Wednesday in February.

**OFFICE HOURS.**—10 to 4. On Saturdays, from the Council Meeting in August until the Council Meeting in April, 10 to 2.

**DISEASES of Cattle, Sheep, and Pigs.**—Members have the privilege of applying to the Veterinary Committee of the Society, and of sending animals to the Royal Veterinary College on the same terms as if they were subscribers to the College.—(A statement of these privileges will be found in the Appendix.)

**CHEMICAL ANALYSIS.**—The privileges of Chemical Analysis enjoyed by Members of the Society will be found stated in the Appendix to the present volume.

**BOTANICAL PRIVILEGES.**—The Botanical Privileges enjoyed by Members of the Society will be found stated in the Appendix to the present volume.

**SUBSCRIPTIONS.**—1. Annual.—The subscription of a Governor is £5, and that of a Member £1, due in advance on the 1st of January of each year, and becoming in arrear if unpaid by the 1st of June. 2. For Life.—Governors may compound for their subscription for future years by paying at once the sum of £50, and Members by paying £10. Members who have paid their annual subscription for 20 years or upwards, and whose subscriptions are not in arrear, may compound for future annual subscriptions, that of the current year inclusive, by a single payment of £5.

**PAYMENTS.**—Subscriptions may be paid to the Secretary, in the most direct and satisfactory manner, either at the office of the Society, No. 12, Hanover Square, London, W., or by means of post-office orders, to be obtained at any of the principal post-offices throughout the kingdom, and made payable to him at the Vere Street Office, London, W.; but any cheque on a banker's or any other house of business in London will be equally available, if made payable on demand. In obtaining post-office orders care should be taken to give the postmaster the correct initials and surname of the Secretary of the Society (H. M. Jenkins), otherwise the payment will be refused to him at the post-office on which such order has been obtained; and when remitting the money-orders it should be stated by whom, and on whose account, they are sent. Cheques should be made payable as drafts on demand (not as bills only payable after sight or a certain number of days after date), and should be drawn on a London (not on a local country) banker. When payment is made to the London and Westminster Bank, St. James's Square Branch, as the bankers of the Society, it will be desirable that the Secretary should be advised by letter of such payment, in order that the entry in the banker's book may be at once identified, and the amount posted to the credit of the proper party. No coin can be remitted by post, unless the letter be registered.

**NEW MEMBERS.**—Every candidate for admission into the Society must be proposed by a Member; the proposer to specify in writing the full name, usual place of residence, and post-town, of the candidate, either at a Council meeting, or by letter addressed to the Secretary. Forms of Proposal may be obtained on application to the Secretary.

**PACKETS BY POST.**—Packets not exceeding two feet in length, width, or depth, consisting of written or printed matter (but not containing letters sealed or open), if sent without envelopes, or enclosed in envelopes open at each end, may be forwarded by the inland post, if stamped, at the following rates:—One Halfpenny for every two ounces or fractional part of that weight.

\* \* \* Members may obtain on application to the Secretary copies of an Abstract of the Charter and Bye-laws, of a Statement of the General Objects, &c., of the Society, of Chemical, Botanical, and Veterinary Privileges, and of other printed papers connected with special departments of the Society's business.

# Royal Agricultural Society of England.

1872.

## DISTRIBUTION OF MEMBERS OF THE SOCIETY AND OF MEMBERS OF COUNCIL.

DISTRICTS.	COUNTIES.	NUMBER OF MEMBERS.	NUMBER IN COUNCIL.	MEMBERS OF COUNCIL.
A.	DURHAM .. .. .	88 ..	1	Hon. H. G. Liddell.
	NORTHUMBERLAND ..	134 ..	2	M. White Ridley; Jacob Wilson.
	YORKSHIRE — NORTH AND EAST RIDINGS	132 ..	3	Earl Cathcart, v.p.; T. C. Booth; John Wells.
		— 354	— 6	
B.	CUMBERLAND .. ..	107 ..	—	
	LANCASHIRE .. ..	213 ..	3	{ Duke of Devonshire, v.p.; Sir T. Hesketh; T. Statter.
	WESTMORELAND ..	30 ..	1	W. H. Wakefield.
	YORKSHIRE — WEST RIDING .. .. .	135 ..	2	{ H. S. Thompson, t.; J. D. Dent.
	— 485	— 6		
C.	DERBYSHIRE .. ..	68 ..	1	Lord Vernon, v.p.
	LEICESTERSHIRE ..	127 ..	2	{ Duke of Rutland, t.; N. C. Stone.
	LINCOLNSHIRE .. ..	191 ..	5	{ R. Hornsby; Lord Kesteven; J. Shuttleworth; W. Torr; W. Earl Welby.
	NORTHAMPTONSHIRE	96 ..		
	NOTTINGHAMSHIRE ..	142 ..	3	{ Viscount Ossington, t.; R. Milward; W. Sanday.
	RUTLANDSHIRE ..	15 ..		
WARWICKSHIRE ..	171 ..	1	J. Baldwin.	
	— 810	— 12		
D.	BEDFORDSHIRE ..	49 ..	1	C. Barnett.
	CAMBRIDGESHIRE ..	61 ..		
	ESSEX .. .. .	114 ..	1	D. McIntosh.
	HERTFORDSHIRE ..	104 ..	1	J. B. Lawes.
	HUNTINGDONSHIRE ..	35 ..	2	Jacob Turner; W. Wells.
	NORFOLK .. .. .	161 ..	2	Earl of Leicester; Robert Leeds.
			Sir E. C. Kerrison, v.p.;	
			N. G. Barthropp; R. C. Ransome; Lieutenant - Colonel Wilson.	
		— 698	— 11	



DISTRIBUTION OF MEMBERS OF THE SOCIETY—*continued.*

STRICTS.	COUNTIES.	NUMBER OF MEMBERS.	NUMBER IN COUNCIL.	MEMBERS OF COUNCIL.
E.	BERKSHIRE .. ..	123 ..	1	Viscount Bridport, t. { Lord Chesham, t.; C. S. Cantrell. Viscount Eversley, v.p.; Sir A. K. Macdonald, t.; T. Pain. C. Whitehead. B. T. Brandreth Gibbs, v.p. Duke of Marlborough, t.; J. Druce. Colonel Challoner, t.; C. E. Amos. Earl of Chichester, v.p.; Earl of Egmont, v.p.; Duke of Richmond, v.p.; W. Rigden.
	BUCKINGHAMSHIRE ..	69 ..	2	
	HAMPSHIRE .. ..	135 ..	3	
	KENT .. .. .	215 ..	1	
	MIDDLESEX .. ..	289 ..	1	
	OXFORDSHIRE .. ..	151 ..	2	
	SURREY .. .. .	136 ..	2	
	SUSSEX .. .. .	128 ..	4	
		—1246	— 16	
F.	CORNWALL .. ..	49		{ Sir T. D. Acland; Sir M. Lopes; G. Turner. Lord Portman, t. Sir W. Miles, v.p. J. Rawlence.
	DEVONSHIRE .. ..	106 ..	3	
	DORSETSHIRE .. ..	69 ..	1	
	SOMERSETSHIRE ..	116 ..	1	
	WILTSHIRE .. ..	93 ..	1	
		— 433	— 6	
G.	GLOUCESTERSHIRE ..	162 ..	4	{ E. Bowly; W. J. Edmonds; E. Holland, t.; Col. Kingscote. G. Clive; C. Wren Hoskyns. Lord Tredegar, t. C. Randell; James Webb.
	HEREFORDSHIRE ..	115 ..	2	
	MONMOUTHSHIRE ..	48 ..	1	
	WORCESTERSHIRE ..	146 ..	2	
	SOUTH WALES ..	114		
		— 585	— 9	
H.	CHESHIRE .. ..	140 ..	2	D.R. Davies; Hon. W. Egerton. { Viscount Hill, v.p.; J. B. Jones. Earl of Lichfield; R. H. Masfen. Earl of Powis, t.; Sir W. Wynn, v.p.
	SHROPSHIRE .. ..	295 ..	2	
	STAFFORDSHIRE ..	256 ..	2	
	NORTH WALES ..	101 ..	2	
		— 792	— 8	
		68		
SCOTLAND .. .. .		83		
IRELAND .. .. .		12		
CHANNEL ISLANDS ..		74		
FOREIGN COUNTRIES ..		95		
MEMBERS WITHOUT ADDRESSES		— 332		

## ROYAL AGRICULTURAL

DR.

## HALF-YEARLY CASH ACCOUNT

	£.	s.	d.	£.	s.	d.
To Balance in hand, 1st July, 1871:—						
Bankers .. .. .	2,448	12	11			
Secretary .. .. .	14	19	9			
At Deposit with London and Westminster Bank .. .. .	2,000	0	0			
				4,463	12	8
To Sale of 500 <i>l.</i> New Three per Centa. .. .. .				459	8	6
To Income:—						
Dividends on Stock .. .. .	359	19	1			
Interest on Deposit Account .. .. .	25	17	2			
Subscriptions:—						
Governors' Annual .. .. .	20	0	0			
Members' Life-Compositions .. .. .	439	0	0			
Members' Annual .. .. .	646	0	0			
				1,105	0	0
Journal:—						
Sales .. .. .	51	10	6			
Advertisements (one year) .. .. .	94	8	0			
				145	18	6
Farm Inspection:—						
Prizes offered by Landowners in Shropshire and Staffordshire .. .. .	241	0	0			
Entry Fees for 1872 .. .. .	29	0	0			
				270	0	0
Sundries .. .. .				10	0	0
Total Income .. .. .	1,916	14	9			
To Wolverhampton Meeting .. .. .	8,935	6	2			
				10,852	0	11
				£15,775	2	1

## BALANCE-SHEET.

LIABILITIES.			£.	s.	d.	£.	s.	d.
To Capital:—								
Surplus, 30th June, 1871 .. .. .			31,097	8	3			
Less Surplus of Expenditure over Income during the Half-year, viz.:—								
Expenditure .. .. .	3,286	9	6					
Income .. .. .	1,916	14	9					
				1,369	14	9		
To Wolverhampton Meeting:—								
Difference between Receipts and Expenditure, the latter exceeding the former by .. .. .						29,727	13	6
						1,944	2	10
						£27,783	10	8

# SOCIETY OF ENGLAND.

FROM 1ST JULY TO 31ST DECEMBER, 1871.

CR.

By Expenditure:—	£	s.	d.	£.	s.	d.	£.	s.	d.
<b>Establishment:—</b>									
Salaries and Wages .. .. .	459	18	0						
House and Office Expenses, Rent, &c. .. .. .	390	6	11						
				850	4	11			
<b>Journal:—</b>									
Printing and Stitching .. .. .	414	9	1						
Postage and Delivery .. .. .	161	9	6						
Ditto, Balance, Vol. VII., Part I. .. .. .	23	10	0						
Essays and Reports .. .. .	165	0	0						
Engravings and Diagrams .. .. .	51	0	6						
Wrappers for 5 Deliveries .. .. .	27	0	0						
				842	9	1			
<b>Chemical:—</b>									
Consulting Chemist's Salary .. .. .				150	0	0			
<b>Veterinary:—</b>									
Grant to Royal Veterinary College (one year) ..	75	0	0						
Grant for Experiments .. .. .	25	0	0						
Investigation at Coldham Hall .. .. .	7	16	0						
				107	16	0			
<b>Botanical:—</b>									
Consulting Botanist's Salary .. .. .				50	0	0			
Education .. .. .				5	5	0			
<b>Farm Inspection:—</b>									
Prizes .. .. .	350	0	0						
Expenses of Judging .. .. .	165	11	10						
				515	11	10			
Postage and Carriage .. .. .				22	8	11			
<b>Sundries:—</b>									
Law Expenses .. .. .	615	17	0						
Illuminating and Binding Vote of Thanks to Mr. Amos .. .. .	33	10	0						
Plans and Specifications for New Tenders for Show Yard Works .. .. .	45	0	0						
Outstanding Manchester and Oxford Accounts ..	43	5	0						
Miscellaneous .. .. .	4	1	9						
				741	13	9			
Subscription (paid in error) returned .. .. .				1	0	0			
<b>Total Expenditure</b> .. .. .							3,286	0	0
<b>By Country Meetings:—</b>									
Wolverhampton .. .. .				11,877	6	6			
Cardiff .. .. .				243	0	0			
							12,120	6	6
<b>By Balance in hand, 31st December:—</b>									
Bankers .. .. .				304	13	5			15,406
Secretary .. .. .				63	12	8			16
							368	6	1
							£15,775	2	1

## 31ST DECEMBER, 1871.

### ASSETS.

	£.	s.	d.
By Cash in hand .. .. .	368	6	1
By New 3 per Cent. Stock 24,112 <i>l.</i> 7 <i>s.</i> 9 <i>d.</i> cost* ..	22,920	7	1
By Books and Furniture in Society's House .. .. .	1,451	17	6
By Country Meeting Plant .. .. .	2,800	0	0
	27,540	10	8
At Credit of Cardiff Meeting .. .. .	243	0	0
	£27,783	10	8

\* Value at 92½ = £22,302 4*s.* 4½*d.*

*Mem.*—The above Assets are exclusive of the amount recoverable in respect of arrears of Subscription to 31st December, 1871, which at that date amounted to 105*l.*

Examined, audited, and found correct, this 19th day of February, 1872.

A. H. JOHNSON, }  
HENRY CANTRELL, } *Auditors on behalf of the Society.*

ROYAL AGRICULTURAL

Dr.

YEARLY CASH ACCOUNT.

	£.	s.	d.	£.	s.	d.	£.
To Balance in hand, 1st Jan. 1871:—							
Bankers . . . . .				1,179	19	0	
Secretary . . . . .				52	2	3	
To Sale of £500 New Three per Cents. . . . .							1,232 459
To Income, viz.:—							
Dividends on Stock . . . . .				722	19	9	
Interest on Deposit Account . . . . .				25	17	2	
Subscriptions:—							
Governors' Life-Compositions . . . . .	40	0	0				
Governors' Annual . . . . .	280	0	0				
Members' Life-Compositions . . . . .	1049	0	0				
Members' Annual . . . . .	3589	18	0				
				4,958	18	0	
Journal:—							
Sales . . . . .	103	11	5				
Advertisements, 1½ year . . . . .	138	10	6				
				242	1	11	
Farm-Inspection, 1871:—							
Prizes offered by Landowners . . . . .	241	0	0				
Entry Fees . . . . .	64	0	0				
Ditto for 1872 . . . . .	29	0	0				
				334	0	0	
Sundries . . . . .							9 4 0
Total Income . . . . .							6,293
To Country Meetings:—							
Oxford . . . . .				8	4	5	
Wolverhampton . . . . .				13,727	18	0	
							13,736

## SOCIETY OF ENGLAND.

FROM 1ST JANUARY TO 31ST DECEMBER, 1871.

CR.

Expenditure:—	£. s. d.	£. s. d.	£. s. d.
<b>Establishment:—</b>			
Salaries and Wages . . . . .	919 16 0		
House and Office Expenses, Rent, Taxes, &c. . . . .	806 8 8	1,726 4 8	
<b>Journal:—</b>			
Printing and Stitching . . . . .	772 15 1		
Postage and Delivery . . . . .	296 1 6		
Essays, Reports, and other contributions . . . . .	266 3 0		
Map of New Forest . . . . .	30 0 0		
Engravings and Diagrams . . . . .	95 10 6		
Advertisements . . . . .	9 0 0		
Wrappers for five deliveries . . . . .	27 0 0	1,496 10 1	
<b>Chemical:—</b>			
Consulting Chemist's Salary . . . . .	300 0 0		
Grant for Investigations . . . . .	200 0 0	500 0 0	
<b>Veterinary:—</b>			
Grant to Royal Veterinary College . . . . .	150 0 0		
Grant for Experiments . . . . .	25 0 0		
Investigation at Coldham Hall . . . . .	7 16 0	182 16 0	
<b>Botanical:—</b>			
Consulting Botanist's Salary, half-year . . . . .		50 0 0	
<b>Arm Inspection, 1871:—</b>			
Advertising, &c. . . . .	34 16 9		
Expenses of Judging . . . . .	165 11 10		
Prizes . . . . .	350 0 0	550 8 7	
<b>Education . . . . .</b>		119 3 6	
<b>Stock: Cost of Transfer to new Trustee . . . . .</b>		3 14 3	
<b>Postage and Carriage . . . . .</b>		65 0 10	
<b>Advertising . . . . .</b>		12 3 6	
<b>Currencies:—</b>			
Law Expenses . . . . .	615 17 0		
Gold Medal, Illuminating and Binding Vote of Thanks to Mr. Amos . . . . .	52 3 0		
Plans and Specifications for New Tender for Showyard Works . . . . .	45 0 0		
Expenses of Inspection Committee . . . . .	17 8 10		
Miscellaneous . . . . .	4 1 9	734 10 7	
<b>Subscriptions (paid in error) returned . . . . .</b>		3 0 0	
<b>Total Expenditure . . . . .</b>			5,443 12 0
<b>Country Meetings:—</b>			
Blymouth . . . . .		10 14 8	
Manchester . . . . .		38 5 0	
xford . . . . .		146 11 4	
Wolverhampton . . . . .		15,470 3 11	
Wardiff . . . . .		243 0 0	15,908 14 11
<b>Balance in hand, 31st Dec:—</b>			21,352 6 11
Bankers . . . . .		304 13 5	
Secretary . . . . .		63 12 8	368 6 1
			£21,720 13 0

COUNTRY MEETING ACCOUNT, WOLVERHAMPTON, 1871.

RECEIPTS.

	£.	s.	d.
Subscription from Wolverhampton	2,000	0	0
Admissions to Show Yard by Payment	7,328	12	4
Admissions by Weekly Tickets	107	2	0
Sale of Catalogues	626	8	6
Implement Exhibitors' Payments for Shedding	1,831	19	4
Non-Members' Fees for entry of implements	213	0	0
Fees for entry of Live-Stock	531	5	0
Fees for Horse-boxes and Stalls	173	0	0
Fees for entry of Cheese, Butter, and Wool.	4	10	0
Premium for Supply of Refreshments	725	0	0
Premium for Creak Rooms and Lavatory	70	0	0
Fines for Non-Exhibition of Live-Stock	21	0	0
Fines for Non-Exhibition of Implements	11	5	0
Extra lines in Implement Catalogue	36	6	0
	<hr/>		
	13,679	8	2
Balance of Expenditure over Receipts	2,174	16	5

EXPENDITURE.

	£.	s.	d.	£.	s.	d.
Show Yard Works—viz. Carriage, Storage, taking to pieces, Packing and Insurance of Permanent Buildings, and other Plant	145	18	1			
Erecting and Painting Buildings	229	11	10			
Other Offices and Buildings	321	15	3			
Implement Sheds	1,565	15	4			
Seed and Model and Cheese and Butter Sheds	481	12	0			
Stock Sheds, 65 <i>l.</i> 5 <i>s.</i> 2 <i>d.</i> ; Hurdles, 23 <i>l.</i> 3 <i>s.</i> 9 <i>d.</i>	893	8	11			
Horse-boxes, 785 <i>l.</i> 6 <i>s.</i> 4 <i>d.</i> ; Fences, Gates, &c. 523 <i>l.</i>	1,308	6	4			
Tents and Fittings, 54 <i>l.</i> 2 <i>s.</i> 3 <i>d.</i> ; Awnings, 94 <i>l.</i> 17 <i>s.</i>	148	19	3			
Other Works	558	12	4			
Trial Field and Trial Yard	231	17	0			
Surveyor	176	3	3			
Judges: Implements, 406 <i>l.</i> 5 <i>s.</i> ; Stock, 320 <i>l.</i> ; Cheese, Butter, and Wool, 40 <i>l.</i>	6,061	19	7			
Consulting Engineers and Assistants	766	5	0			
Inspectors: Veterinary, 76 <i>l.</i> 10 <i>s.</i> 6 <i>d.</i> ; Shearing, 30 <i>l.</i>	364	5	0			
Police: Metropolitan, 259 <i>l.</i> 11 <i>s.</i> 8 <i>d.</i> ; Local, 43 <i>l.</i> 6 <i>s.</i>	106	10	6			
Clerks and Assistants: Secretary and Official Staff, 67 <i>l.</i> 0 <i>s.</i> 11 <i>d.</i> ; Hon. Director, 38 <i>l.</i> 17 <i>s.</i> 8 <i>d.</i> ; Bankers, 23 <i>l.</i> 2 <i>s.</i> ; Post-office, 3 <i>l.</i> 3 <i>s.</i>	302	17	8			
Assistant Steward of Implements	132	3	7			
Foremen: Trial Fields, 36 <i>l.</i> 15 <i>s.</i> 4 <i>d.</i> ; Implement Yard, 10 <i>l.</i> 18 <i>s.</i> 6 <i>d.</i> ; Stock Yard, 20 <i>l.</i> ; Horses, 11 <i>l.</i> ; Cattle, 8 <i>l.</i> 5 <i>s.</i> ; Forage, 12 <i>l.</i> 3 <i>s.</i>	50	8	0			
Yardmen, Fieldmen, Poddermen, and Grooms	98	1	10			
Index-clerk and Money-takers, 54 <i>l.</i> 6 <i>s.</i> 6 <i>d.</i> ; Money-changer and Door-keepers, 47 <i>l.</i> 8 <i>s.</i>	234	9	4			
Refreshments for Stewards, Judges, and other Officials	101	14	6			
Lodgings for ditto	223	13	6			
Catalogues: Implements, 404 <i>l.</i> 17 <i>s.</i> ; Awards, 11 <i>l.</i> 7 <i>s.</i> 6 <i>d.</i> ; Stock, 162 <i>l.</i> 19 <i>s.</i> ; Awards, 56 <i>l.</i> 5 <i>s.</i> 6 <i>d.</i> ; Plan of Yard, 12 <i>l.</i> 10 <i>s.</i> ; Sellers, 43 <i>l.</i> 1 <i>s.</i> ; Carriage and Packing, 33 <i>l.</i> 9 <i>s.</i>	226	10	6			
Printing	724	8	0			
Advertising and Bill-Posting	436	11	2			
Hay, 2111 <i>l.</i> 15 <i>s.</i> ; Straw, 306 <i>l.</i> 11 <i>s.</i> 5 <i>d.</i> ; Green Food, 300 <i>l.</i>	703	16	10			
Postage, Telegrams, Carriage, Stationery, Badges, &c.	818	6	5			
Repairs, Insurance, and Carriage of Testing Machines, Additions, &c., and Sundries	143	18	3			
Hire of Engines and Waggons	333	18	2			
Horse Hire and Carriage of Implements to Trial Fields, 247 <i>l.</i> 0 <i>s.</i> 11 <i>d.</i> ; Carriage and Cab Hire for Stewards, Judges, &c., 38 <i>l.</i> 19 <i>s.</i>	77	5	4			
Hire of Extra Trial Land	272	19	11			
Coal, 46 <i>l.</i> 9 <i>s.</i> 4 <i>d.</i> ; Petty Payments at Trials, 40 <i>l.</i> 15 <i>s.</i> 7 <i>d.</i>	228	4	6			
Surveyor at Trials, 15 <i>l.</i> 13 <i>s.</i> ; Shorthand Writer, &c., 8 <i>l.</i> 17 <i>s.</i> 10 <i>d.</i>	87	4	11			
Fire-Engine Men, 4 <i>l.</i> ; Messenger, 1 <i>l.</i> 15 <i>s.</i>	24	9	10			
Tarred Line, Hire of Mower, and sundry other Payments	5	15	0			
Rosettes	26	0	3			
Prizes: Stock, 2,665 <i>l.</i> ; Implement, 615 <i>l.</i> ; Medals, 7 <i>l.</i> 4 <i>s.</i>	15	3	0			
	3,987	4	0			

## Cardiff Meeting, 1872:

ON MONDAY THE 15TH OF JULY, AND FOUR FOLLOWING DAYS.

## SCHEDULE OF PRIZES.

## I.—LIVE-STOCK PRIZES.

The Prizes offered by the Cardiff Local Committee are marked thus\* ; and those offered by the Glamorganshire General Agricultural Society, thus †.

Reference Number in Certificates.	HORSES.	First Prize.	Second Prize.	Third Prize.
Class		£.	£.	£.
1	Agricultural Stallion, foaled before 1st Jan. 1870, <i>not qualified to compete as Clydesdale or Suffolk</i>	25	15	5
2	Agricultural Stallion, foaled in the year 1870, <i>not qualified to compete as Clydesdale or Suffolk</i> ..	20	10	5
3	Clydesdale Stallion, foaled before the 1st Jan. 1870	25	15	5
4	Clydesdale Stallion, foaled in the year 1870 ..	20	10	5
5	Suffolk Stallion, foaled before the 1st of Jan. 1870	25	15	5
6	Suffolk Stallion, foaled in the year 1870 .. ..	20	10	5
7	Thorough-bred Stallion, suitable for getting hunters	50	25	10
8	Stallion, above 14 hands but not exceeding 15 hands 2 inches, suitable for getting Hackneys ..	20	10	5
9	Pony Stallion, not exceeding 14 hands .. ..	15	10	5
10	Pony Stallion, not exceeding 13 hands .. ..	15	10	5
11	Agricultural Mare, in foal, or with foal at foot, <i>not suitable to compete as Clydesdale or Suffolk</i> ..	20	10	5
12	Clydesdale Mare, in foal, or with foal at foot ..	20	10	5
13	Suffolk Mare, in foal, or with foal at foot .. ..	20	10	5
14	Mare, in foal, or with foal at foot, suitable for breeding Hunters .. .. .	25	15	5
15	Mare, above 14 hands, but not exceeding 15 hands 1 inch, in foal, or with foal at foot, suitable for breeding Hackneys .. .. .	20	10	5
16	Pony Mare, not exceeding 14 hands .. .. .	10	5	..
17	Pony Mare, not exceeding 13 hands .. .. .	10	5	..
18	Welsh Pony, not exceeding 13 hands (any age or sex) .. .. .	† 10	† 5	..
19	Agricultural Filly, two years old, <i>not qualified to compete as Clydesdale or Suffolk</i> .. .. .	15	10	5
20	Clydesdale Filly, two years old .. .. .	15	10	5
21	Suffolk Filly, two years old .. .. .	15	10	5
22	Hunter, Mare or Gelding, up to not less than 15 stone .. .. .	* 20	* 10	* 5

No Third Prize will be given unless at least Six animals be exhibited, and no Second Prize will be given unless at least Three animals be exhibited, except on the special recommendation of the Judges.

## Prizes for Live Stock.

Reference Number in Certificates.	HORSES— <i>continued.</i>	First Prize.	Second Prize.	Third Prize.	Fourth Prize.
Class		£.	£.	£.	£.
23	Hunter, Mare or Gelding, up to not less than 12 stone .. .. .	*20	*10	*5	
24	Hunter, Mare or Gelding, four years old, without restriction .. .. .	*20	*10	*5	
25	Hunter, Mare or Gelding, three years old, without restriction .. .. .	*20	*10	*5	
26	Hunter, Gelding or Filly, by a thorough-bred horse, two years old .. .. .	*10	*5		
27	Hunter, Gelding or Filly, 1 year old, by a thorough-bred horse .. .. .	*10	*5		
28	Roadster, Mare or Gelding, above 14 hands 1 inch, but not exceeding 15 hands .. .. .	*15	*10		
29	Cob, Mare or Gelding, above 13 hands, and not exceeding 14 hands 1 inch .. .. .	†15	†10		
30	Agricultural Mare or Gelding, three years old .. .. .	*10	*5		
31	Agricultural Mare or Gelding, two years old .. .. .	*10	*5		
32	Agricultural Mare or Gelding, one year old .. .. .	*10	*5		
33	Pair of Agricultural Geldings or Mares (any age)	†20	†10		
34	Pair of Draught Geldings or Mares for underground purposes, not exceeding 15 hands high (any age)	†20	†10		

*No Third Prize will be given unless at least Six animals be exhibited, and no Second Prize will be given unless at least Three animals be exhibited, except on the special recommendation of the Judges.*

## CATTLE.

(ALL AGES CALCULATED TO JULY 1ST, 1872).

## SHORTHORN.

35	Bull, above three years old .. .. .	30	20	15	1
36	Bull, above two and not exceeding three years old	25	15	10	
37	Yearling Bull, above one and not exceeding two years old .. .. .	25	15	10	
38	Bull-Calf, above six and not exceeding twelve months old .. .. .	15	10	5	
39	Cow, above three years old .. .. .	20	10	5	
40	Heifer, in-milk or in-calf, not exceeding three years old .. .. .	15	10	5	
41	Yearling Heifer, above one and not exceeding two years old .. .. .	15	10	5	
42	Heifer-Calf, above six and under twelve months old	10	5		

*No Third Prize will be given unless at least Six animals be exhibited, and no Second Prize will be given unless at least Three animals be exhibited; and in Classes 35, 36 and 37 no Fourth Prize will be given unless at least Ten animals be exhibited, except on the special recommendation of the Judges.*



Reference Number in Exhibitors.	CATTLE— <i>continued.</i>	First Prize.	Second Prize.	Third Prize.
	HEREFORD.	£.	£.	£.
43	Bull, above three years old .. .. .	25	15	5
44	Bull, above two and not exceeding three years old	25	15	5
45	Yearling Bull, above one and not exceeding two years old .. .. .	25	15	5
46	Bull-Calf, above six and not exceeding twelve months old .. .. .	10	5	..
47	Cow, above three years old .. .. .	20	10	5
48	Heifer, in-milk or in-calf, not exceeding three years old .. .. .	15	10	5
49	Yearling Heifer, above one and not exceeding two years old .. .. .	15	10	5
50	Heifer-Calf, above six and under twelve months old	10	5	..
	DEVON.			
51	Bull, above three years old .. .. .	25	15	5
52	Bull, above two and not exceeding three years old	25	15	5
53	Yearling Bull, above one and not exceeding two years old .. .. .	25	15	5
54	Bull-Calf, above six and not exceeding twelve months old .. .. .	10	5	..
55	Cow, above three years old .. .. .	20	10	5
56	Heifer, in-milk or in-calf not exceeding three years old .. .. .	15	10	5
57	Yearling Heifer, above one and not exceeding two years old .. .. .	15	10	5
58	Heifer-Calf, above six and under twelve months old	10	5	..
	JERSEY.			
59	Bull, above one year old .. .. .	10	5	..
60	Cow, above three years old .. .. .	10	5	..
61	Heifer, in-milk or in-calf, not exceeding three years old .. .. .	10	5	..
	GUERNSEY.			
62	Bull, above one year old .. .. .	10	5	..
63	Cow, above three years old .. .. .	10	5	..
64	Heifer, in-milk or in-calf, not exceeding three years old .. .. .	10	5	..
	<i>No Third Prize will be given unless at least Six animals be exhibited, and no Second Prize will be given unless at least Three Animals be exhibited, except on the special recommendation of the Judges.</i>			

Reference Number in Certificates.	CATTLE— <i>continued.</i>	First Prize.	Second Prize.	Third Prize.
Class	WELSH BREEDS.	£.	£.	£.
	<i>(Including the Castle Martin Breed.)</i>			
65	Bull, three years, or over .. .. .	15	10	..
66	Bull, between two and three years .. .. .	15	10	..
67	Yearling Bull .. .. .	15	10	..
68	Heifer, of between two and three years .. .. .	15	10	..
69	Yearling Heifer .. .. .	15	10	..
	CASTLE MARTIN BREED.			
70	Pair of Heifers, under three years old, in-milk or in-calf .. .. .	†15	†10	..
71	Pair of Cows, over three years, in milk or in calf .. .. .	†15	†10	..
	OTHER ESTABLISHED BREEDS.			
	<i>Not including the Shorthorn, Hereford, Devon, Jersey, Guernsey, or Welsh Breeds.</i>			
72	Bull, above one year old .. .. .	10	5	..
73	Cow, above three years old .. .. .	10	5	..
74	Heifer, in-milk or in-calf, not exceeding three years old .. .. .	10	5	..
75	Bull, Cow, and their Offspring, of any pure breed .. .. .	*20	*10	..
	DAIRY CATTLE.			
76	†Pair of Cows, over three years and eight months old, in milk .. .. .	†15	†10	†5
	<i>No Third Prize will be given unless at least Six animals be exhibited, and no Second Prize will be given unless at least Three animals be exhibited, except on the special recommendation of the Judges.</i>			

Reference number in certificates.		First Prize.	Second Prize.	Third Prize.
	<b>SHEEP.</b>			
	<b>LEICESTER.</b>	£.	£.	£.
77	Shearling Ram .. .. .	20	10	5
78	Ram of any other age .. .. .	20	10	5
79	Pen of Five Shearling Ewes, of the same flock ..	15	10	5
	<b>COTSWOLD.</b>			
80	Shearling Ram .. .. .	20	10	5
81	Ram of any other age .. .. .	20	10	5
82	Pen of Five Shearling Ewes, of the same flock ..	15	10	5
83	Pen of Five Cotswold Ram Lambs .. .. .	† 15	10	
	<b>LINCOLNS.</b>			
84	Shearling Ram .. .. .	20	10	5
85	Ram of any other age .. .. .	20	10	5
86	Pen of Five Shearling Ewes, of the same flock ..	15	10	5
	<b>LONG-WOOLS.</b>			
87	Pen of Ten Ewes, with their lambs, of any Long-Wool bred .. .. .	† 10	† 5	..
	<b>OXFORDSHIRE DOWN.</b>			
88	Shearling Ram .. .. .	20	10	5
89	Ram of any other age .. .. .	20	10	5
90	Pen of Five Shearling Ewes, of the same flock ..	15	10	5
	<b>SOUTHDOWN.</b>			
91	Shearling Ram .. .. .	20	10	5
92	Ram of any other age .. .. .	20	10	5
93	Pen of Five Shearling Ewes, of the same flock ..	15	10	5
	<b>SHROPSHIRE.</b>			
94	Shearling Ram .. .. .	20	10	5
95	Ram of any other age .. .. .	20	10	5
96	Pen of Five Shearling Ewes, of the same flock ..	15	10	5
	<i>No Third Prize will be given unless at least Six animals be exhibited, and no Second Prize will be given unless at least Three animals be exhibited, except on the special recommendation of the Judges. This rule is applied to the Ewe and Lamb Classes by substituting the word "pens" for "animals."</i>			

Reference Number in Certificates.		First Prize.	Second Prize.	Third Prize.
	<b>SHEEP—continued.</b>			
Class	<b>HAMPSHIRE AND OTHER SHORT-WOOLLED BREEDS.</b>	£.	£.	£.
	<i>Not qualified to compete as Southdown or Shropshire.</i>			
97	Shearling Ram .. .. .	20	10	
98	Ram of any other age .. .. .	20	10	
99	Pen of Five Shearling Ewes, of the same flock ..	15	10	
	<b>DORSET.</b>			
100	Shearling Ram .. .. .	10	5	
101	Ram of any other age .. .. .	10	5	
102	Pen of Five Shearling Ewes .. .. .	10	5	
	<b>CHEVIOTS.</b>			
103	Shearling Ram .. .. .	10	5	
104	Ram of any age .. .. .	10	5	
105	Pen of Five Ewes of any age .. .. .	10	5	
	<b>RADNOR SHEEP.</b>			
106	Shearling Ram .. .. .	10	5	
107	Ram of any other age .. .. .	†10	†5	
108	Pen of Five Ewes of any age .. .. .	†10	†5	
	<b>MOUNTAIN SHEEP.</b>			
	<i>Not qualified to compete as Cheviots.</i>			
109	Ram of any age .. .. .	10	5	
110	Pen of Five Ewes of any age .. .. .	10	5	
	<p><i>No Third Prize will be given unless at least Six animals be exhibited, and no Second Prize will be given unless at least Three animals be exhibited, except on the special recommendation of the Judges. This rule is applied to the Ewe and Lamb Classes by substituting the word "pens" for "animals."</i></p>			

Reference number in certificates.		First Prize.	Second Prize.	Third Prize.
	<b>PIGS.</b>			
	<b>LARGE WHITE BREED.</b>			
Class		£.	£.	£.
111	Boar, above twelve months old .. .. .	10	5	..
112	Boar, above six months and not exceeding twelve months old .. .. .	10	5	..
113	Breeding Sow .. .. .	10	5	..
114	Pen of three Breeding Sow-Pigs of the same litter, above four and under eight months old .. ..	10	5	..
	<b>SMALL WHITE BREED.</b>			
115	Boar, above twelve months old .. .. .	10	5	..
116	Boar, above six months and not exceeding twelve months old .. .. .	10	5	..
117	Breeding Sow .. .. .	10	5	..
118	Pen of three Breeding Sow-Pigs of the same litter, above four and under eight months old .. ..	10	5	..
	<b>SMALL BLACK BREED.</b>			
119	Boar, above twelve months old .. .. .	10	5	..
120	Boar, above six months and not exceeding twelve months old .. .. .	10	5	..
121	Breeding Sow .. .. .	10	5	..
122	Pen of three Breeding Sow-Pigs of the same litter, above four and under eight months old ..	10	5	..
	<b>BERKSHIRE BREED.</b>			
123	Boar, above twelve months old .. .. .	10	5	..
124	Boar, above six months and not exceeding twelve months old .. .. .	10	5	..
125	Breeding Sow .. .. .	10	5	..
126	Pen of three Breeding Sow-Pigs of the same litter, above four and under eight months old .. ..	10	5	..
	<b>OTHER BREEDS.</b>			
	<i>Not eligible to compete in any of the preceding Classes.</i>			
127	Boar .. .. .	10	5	..
128	Breeding Sow .. .. .	10	5	..
129	Pen of three Breeding-Sow Pigs of the same litter above four and under eight months old .. ..	10	5	..
	<i>No Second Prize will be given unless at least Three animals be exhibited, except on the special recommendation of the Judges.</i>			

Reference Number in Certificates.		First Prize.	Second Prize.	Third Prize.
	<b>BUTTER.</b>			
Class.		£.	£.	£.
130	6 lbs., to be made up in lbs. . . . .	*5	*3	*2
	<b>CHEESE.</b>			
131	Over 6 inches thick, and not less than 1 cwt. . .	*10	*5	*2
132	Under 6 inches, and not less than 56 lbs. . . .	*10	*5	*2

## II.—IMPLEMENT AND MACHINERY PRIZES OFFERED BY THE SOCIETY.

Class		£.
1.	For the best Portable Steam-Engine (not self-moving), not exceeding 8-horse power . . . . .	40
	For the second best ditto . . . . .	20
2.	For the best Combined Portable Threshing and Finishing Machine, to be worked by steam, and adapted to the preparation of corn for market . . . . .	40
	For the second best ditto . . . . .	20
3.	For the best Combined Portable Threshing Machine, to be worked by steam, which has no corn-screen or other apparatus for sorting the grain for market . . . . .	40
	For the second best ditto . . . . .	20
4.	For the best Straw Elevator, to be worked by steam in conjunction with a Threshing Machine . . . . .	10
	For the second best ditto . . . . .	5
5.	For the best Straw or Hay Elevator, to be worked by horse-power . .	10
	For the second best ditto . . . . .	5
6.	For the best Seed Drawer . . . . .	10
7.	For the best Corn Dressing Machine . . . . .	15
	For the second best ditto . . . . .	10
	For the third best ditto . . . . .	5
8.	For the best Corn Screen . . . . .	10
	For the second best ditto . . . . .	5

### MISCELLANEOUS.

Awards to Agricultural Articles not included in the Quinquennial rotation . . . . . 10 Silver Medals.

In the Classes for which one Prize only is offered, the Judges will be empowered to divide it equally between two competing Implements, if they consider them equal in merit.

## CONDITIONS APPLYING TO CERTAIN CLASSES OF LIVE STOCK ONLY.

### CATTLE.

1. No bull above two years old will be eligible for a prize unless certified to have served not less than three different cows (or heifers) within the three months preceding the 1st of June in the year of the Show.

2. All bulls above one year old shall have rings or "bull-dogs" in their noses, and be provided with leading sticks.

3. No cow will be eligible for a prize unless certified either at the date of entry or between the date of entry and that of the Show, to have had a living calf, or that the calf, if dead, was born at its proper time, within the twelve months preceding the date of the Show.

4. No heifer, except yearlings, entered as in-calf, will be eligible for a prize unless she is certified to have been bulled before the 31st of March in the year of the Show, nor will her owner afterwards receive the prize until he shall have furnished the Secretary with a further certificate before the 31st of January in the subsequent year, that she produced a living calf; or that the calf, if dead, was born at its proper time.

5. Shorthorns.—Each animal entered in the Shorthorn Classes, must be certified by the Exhibitor to have not less than four crosses of Shorthorn blood which are registered in the herd book.

### HORSES.

6. All foals must be the offspring of the mare along with which they are exhibited; and the sire of the foal must be given on the certificate of entry as well as sire of the mare.

7. No mare will be eligible for a prize unless certified either at the date of entry, or between the date of entry and that of the Show, and to have had a living foal—or that the foal, *if dead*, was born at its proper time, in the year of the Show;—or in the event of a mare being exhibited *without* a foal at foot, a certificate shall be produced at the time of entry of her having been served, and the prize shall be withheld till a certificate be produced of her having produced a foal.

8. No veterinary inspection of horses will be required except when considered necessary by the Judges, who will be accompanied by the Veterinary Inspectors.

9. A charge of 1*l.* for the accommodation of a horse-box will be made for each entry for stallions and mares in-foal, or with foals at foot, which includes hay, straw, and green fodder.

10. A charge of 10*s.* will be made for the accommodation of a stall for each entry in the other Horse Classes, which includes hay, straw, and green fodder.

## SHEEP.

11. All rams, except shearlings, must have been used in the present year.

12. Sheep exhibited for any of the prizes must have been *really and fairly shorn bare* after the 1st of April in the year of the Exhibition; and the date of such shearing must form part of the Certificate of Entry. Three Inspectors will be appointed by the Council to examine the sheep on their admission to the Show-Yard, with instructions to report to the Stewards any cases in which the sheep have not been *really and fairly shorn bare*.

13. Sheep unfairly prepared for Show by oiling or colouring may be disqualified on the recommendation of the Inspectors of Shearing.

## PIGS.

14. The three sow-pigs in each pen must be of the same litter.

15. The breeding sows in Classes 113, 117, 121, 125, and 128, shall be certified to have had a litter of live pigs within the six months preceding the Show, or to be in-pig at the time of entry, so as to produce a litter before the 1st of September following. In the case of in-pig sows, the prize will be withheld until the Exhibitor shall have furnished the Secretary with a certificate of farrowing, as above.

16. No sow, if above eighteen months old, that has not produced a litter of live pigs, shall be eligible to compete in any of the classes.

17. The Judges of pigs will be instructed, with the sanction of the Stewards, to withhold prizes from any animals which shall appear to them to have been entered in a wrong class.

18. All pigs exhibited at the Country Meetings of the Society shall be subjected to an examination of their mouths by the Veterinary Inspector of the Society; and should the state of dentition in any pig indicate that the age of the animal has not been correctly returned in the Certificate of Entry, the Stewards shall have power to disqualify such pig, and shall report the circumstance to the Council at its ensuing Monthly Meeting. No pig shall be oiled or coloured while in the Show-Yard.

19. If a litter of pigs be sent with a breeding sow, the young pigs must be the produce of the sow, and must not exceed two months old.

20. All disqualifications will be published in the awards of the Judges.



## RULES OF ADJUDICATION.

---

1. As the object of the Society in giving prizes for cattle, sheep, and pigs, is to promote improvement in *breeding* stock, the Judges in making their awards will be instructed not to take into their consideration the present value to the butcher of animals exhibited, but to decide according to their relative merits for the purpose of *breeding*.

2. If, in the opinion of the Judges, there should be equality of merit, they will be instructed to make a special report to the Council, who will decide on the award.

3. The Judges will be instructed to withhold any prize if they are of opinion that there is not sufficient merit in any of the stock exhibited for such prize to justify an award.

4. The Judges will be instructed to give in a *Reserved Number* in each class of live stock; viz., which animal would, in their opinion, possess sufficient merit for the prize, in case the animal to which the prize is awarded should subsequently become disqualified.

5. In the classes for stallions, mares, and fillies, the Judges in awarding the prizes will be instructed, in addition to symmetry, to take activity and strength into their consideration.

6. The attention of the Stewards and Judges is particularly called to the conditions applying to pigs. The Senior Steward of Live Stock is requested to report any malpractices on the part of Exhibitors, and any person found guilty will not be allowed to exhibit at future meetings of the Society.

**CONDITIONS RELATING TO MACHINERY.****STEAM ENGINES.**

All Engines must be fitted with a Steam-Indicator, in addition to the ordinary Spring-Balance, which Indicator must be proved by the Indicator of the Society.

**PORTABLE ENGINES.**

1. All the general conditions respecting Steam-Engines and boilers will have to be observed.

2. The nominal power of the engines entered for trial will be taken at one-third the indicated power, at 60 lbs. pressure in the boiler, cutting off at three-fourths the stroke, and the periphery of the fly-wheel running 1884 feet per minute.

3. The engines will be tested by the Society's friction-breaks, worked by means of connecting-rod and universal joints direct from the crank-shaft. Each engine entered will have to be fitted with a clutch, shown in detail in Fig. 4, Form A of Engineer's Instructions; and to facilitate the Society's arrangements, the height of the crank-shaft of each engine above the ground must be stated when the specification is sent in to the Secretary.

4. The engines will be tested for economy in coal, water, lubrication, and steadiness in running. Indicator diagrams will also be taken, and therefore the preparations for receiving the indicators, described in Form A, must be provided.

5. During the trial-runs one man only will be allowed to attend the engine. Over or under-running will not be permitted; steady running, as nearly as possible at the speed declared at entry, will be considered a point of merit. The engines must be fitted with governors, and the efficiency of the latter will be tested after the trials for economy of working are over, by suddenly varying the load on the brake.

6. Exhibitors shall, on making their final specifications, elect at what steam-pressure, not exceeding the declared pressure, what horse-power on the brake, and what number of revolutions they would wish to be tried.

7. The order in which the several engines will be tested will be determined by the Stewards, who will decide by lot.

8. Detached feed-water-heaters, not ordinarily sold with engines, and included in the prices entered, will not be allowed, but heaters permanently fixed to the engines or arrangements for carrying waste steam to the water-tanks, provided they are included in the price of the engine, will be admitted.

9. The trials of the Steam-Engines will be made with Llangennech coal.

**THRASHING MACHINES.**

10. The Threshing Machines will be driven by a portable engine through a registering dynamometer, both provided by the Society. The driving-pulleys on the machines must be adapted to 1884 feet per minute speed of driving belt.

11. The merits of the machines will depend upon the price, economy of power and time; the marks obtained for clean threshing, clean shaking,

freedom from cavings, freedom of chaff from corn, from cavings, and from seeds, unbroken straw, uninjured corn, cleanness of delivery from the machine, and perfection of finishing in Class 2. The points representing perfection will be as under :—

	CARDIFF.
Clean Threshing .. .. .	150
Clean Shaking .. .. .	40
Freedom from Cavings .. .. .	30
Chaff free from Corn .. .. .	50
Chaff free from Cavings .. .. .	20
Chaff free from Seeds .. .. .	40
Straw unbroken .. .. .	20
Corn uninjured .. .. .	70
Cleanness of delivery from machine, <i>i.e.</i> , absence of lodgment in screens, &c. .. .. .	10
Perfection of Finishing, that is, screening or sorting, in Class II. only .. .. .	20
	450

12. The sheaves to be threshed will be kept under cover; the stacks will be worked down vertically, so as to give each machine as nearly as possible the same quality of work; the sheaves will be served out by weight to each machine. The straw resulting will be re-threshed, and the various products delivered by the machines, as well as the corn separated by the second threshing, will be carefully weighed and samples set apart for final comparison.

13. Means must be provided for examining the inside of the machines as perfectly as possible, in order to ascertain how completely the various products are delivered. It will be a point of merit in a machine to empty itself completely, and leave no lodgment in the screens, &c.

14. Those machines which appear to the Judges of sufficient merit, will be run for a prolonged trial, in order to enable a more correct and satisfactory judgment of their merits to be arrived at.

#### CLASSES IV.—VIII.

15. The Machines in classes IV., V., VI., VII., and VIII., will be judged chiefly with reference to the manner in which they perform their work, to the goodness of design and workmanship, and to their cost. Dynamometers will be used whenever the judges think it advisable to determine the amount of power necessary to drive the machines.

\* \* Forms of Certificate for entry, as well as Prize-Sheets for the Cardiff Meeting, containing the whole of the conditions and regulations, may be obtained at the Office of the Society, No. 12, Hanover Square, London, W.

#### DATES OF ENTRY.

CERTIFICATES for the entry of Implements for the Cardiff Meeting must be forwarded to the Secretary of the Society, No. 12, Hanover Square, London, W., by the 1st of May, and Certificates for the entry of Live Stock by the 1st of June. Certificates received after those respective dates will not be accepted, but returned to the persons by whom they have been sent.

The Prizes of the Royal Agricultural Society of England, and all Prizes offered by the Cardiff Local Committee, and the Glamorganshire General Agricultural Society, are open to general competition.

## PRIZES FOR COTTAGES.

1. For plans, elevations, and sections, with detailed plans and specifications, and a priced bill of quantities for all trade-work connected with building a Pair of Cottages, suitable for the use of agricultural labourers, having not less than three bedrooms, a brick oven, and suitable offices.

First Prize, given by the Marquess of Bute	.. .. .	£.
Second Prize, given by Major Picton Turbervill	.. .. .	20
		10

2. For plans, elevations, and sections, with detailed plans and specifications, and a priced bill of quantities for all trade-work connected with building Two Cottages, to form part of a row, suitable for the mineral districts, and having not less than three bedrooms and suitable offices.

First Prize, given by the Marquess of Bute	.. .. .	£.
Second Prize, given by Major Picton Turbervill	.. .. .	20
		10

## CONDITIONS.

All plans, elevations, sections, &c., must be drawn to a scale of  $\frac{1}{4}$ -inch to 1 foot. Materials must be assumed as delivered on the spot at the following prices, viz. :—

Stone	.. .. .	2s. per cubic yard.
Brick	.. .. .	33s. per 1000.
Timber	.. .. .	1s. 9d. cubic foot, sawn.
Slates (Princesses)	.. .. .	£12 per 1000.
Lime	.. .. .	8s. 6d. per ton.
Paving Stones	.. .. .	2s. per square yard.

No Prizes will be awarded to any design for a pair of Labourers' Cottages, the cost of erecting which would exceed 220*l.*; nor for a single Cottage for the Mineral Districts, the cost of which would exceed 90*l.*

Each design must bear an assumed name, and be accompanied by a sealed envelope containing the real name and address of the competitor, and must be sent to the Secretary, 12, Hanover Square, on or before 1st July.

The Prize Designs must remain the property of the Glamorganshire General Agricultural Society; but the right of publishing them will remain with the designer.

## Members' Veterinary Privileges.

### I.—SERIOUS OR EXTENSIVE DISEASES.

No. 1. Any Member of the Society who may desire professional attendance and special advice in cases of serious or extensive disease among his cattle, sheep, or pigs, and will address a letter to the Secretary, will, by return of post, receive a reply stating whether it be considered necessary that Professor Simonds, the Society's Veterinary Inspector, should visit the place where the disease prevails.

No. 2. The remuneration of the Inspector will be 2*l.* 2*s.* each day as a professional fee, and 1*l.* 1*s.* each day for personal expenses; and he will also be allowed to charge the cost of travelling to and from the locality where his services may have been required. The fees will be paid by the Society, but the travelling expenses will be a charge against the applicant. This charge may, however, be reduced or remitted altogether at the discretion of the Council, on such step being recommended to them by the Veterinary Committee.

No. 3. The Inspector, on his return from visiting the diseased stock, will report to the Committee, in writing, the results of his observations and proceedings, which Report will be laid before the Council.

No. 4. When contingencies arise to prevent a personal discharge of the duties confided to the Inspector, he may, subject to the approval of the Committee, name some competent professional person to act in his stead, who shall receive the same rates of remuneration.

### II.—ORDINARY OR OTHER CASES OF DISEASE.

Members may obtain the attendance of the Veterinary Inspector on any case of disease by paying the cost of his visit, which will be at the following rate, viz., 2*l.* 2*s.* per diem, and travelling expenses.

### III.—CONSULTATIONS WITHOUT VISIT.

Personal consultation with Veterinary Inspector .. .. .	5 <i>s.</i>
Consultation by letter .. .. .	5 <i>s.</i>
Consultation necessitating the writing of three or more letters.	10 <i>s.</i>
Post-mortem examination, and report thereon .. .. .	10 <i>s.</i>

A return of the number of applications during each half-year being required from the Veterinary Inspector.

### IV.—ADMISSION OF DISEASED ANIMALS TO THE VETERINARY COLLEGE INVESTIGATIONS; LECTURES, AND REPORTS.

No. 1. All Members of the Society have the privilege of sending cattle, sheep, and pigs to the Infirmary of the Royal Veterinary College, on the same terms as if they were Members of the College; viz., by paying for the keep and treatment of cattle 10*s.* 6*d.* per week each animal, and for sheep and pigs "a small proportionate charge to be fixed by the Principal according to circumstances."

No. 2. The College has also undertaken to investigate such particular classes of disease, or special subjects connected with the application of the Veterinary art to cattle, sheep, and pigs, as may be directed by the Council.

No. 3. In addition to the increased number of lectures now given by Professor Simonds—the Lecturer on Cattle Pathology—to the pupils in the Royal Veterinary College, he will also deliver such lectures before the Members of the Society, at their house in Hanover Square, as the Council shall decide.

No. 4. The Royal Veterinary College will from time to time furnish to the Council a detailed Report of the cases of cattle, sheep, and pigs treated in the Infirmary.

By order of the Council,

H. M. JENKINS, *Secretary.*

## Members' Privileges of Chemical Analysis.

THE Council have fixed the following rates of Charge for Analyses to be made by the Consulting Chemist for the *bonâ fide* use of Members of the Society; who (to avoid all unnecessary correspondence) are particularly requested, when applying to him, to mention the kind of analysis they require, and to quote its number in the subjoined schedule. The charge for analysis, together with the carriage of the specimens, must be paid to him by members at the time of their application.

No. 1.—An opinion of the genuineness of Peruvian guano, bone-dust, or oil-cake (each sample) .. .. .	5s.
„ 2.—An analysis of guano; showing the proportion of moisture, organic matter, sand, phosphate of lime, alkaline salts, and ammonia .. .. .	10s.
„ 3.—An estimate of the value (relatively to the average of samples in the market) of sulphate and muriate of ammonia, and of the nitrates of potash and soda .. .. .	10s.
„ 4.—An analysis of superphosphate of lime for soluble phosphates only .. .. .	10s.
„ 5.—An analysis of superphosphate of lime, showing the proportions of moisture, organic matter, sand, soluble and insoluble phosphates, sulphate of lime, and ammonia ..	£1.
„ 6.—An analysis (sufficient for the determination of its agricultural value) of any ordinary artificial manure .. .. .	£1.
„ 7.—Limestone:—the proportion of lime, 7s. 6d.; the proportion of magnesia, 10s.; the proportion of lime and magnesia .. .. .	15s.
„ 8.—Limestone or marls, including carbonate, phosphate, and sulphate of lime, and magnesia with sand and clay ..	£1.
„ 9.—Partial analysis of a soil, including determinations of clay, sand, organic matter, and carbonate of lime .. .. .	£1.
„ 10.—Complete analysis of a soil .. .. .	£3.
„ 11.—An analysis of oil-cake, or other substance used for feeding purposes; showing the proportion of moisture, oil, mineral matter, albuminous matter, and woody fibre; as well as of starch, gum, and sugar, in the aggregate ..	£1.
„ 12.—Analyses of any vegetable product .. .. .	£1.
„ 13.—Analyses of animal products, refuse substances used for manure, &c. .. .. .	from 10s. to 30s.
„ 14.—Determination of the “hardness” of a sample of water before and after boiling .. .. .	10s.
„ 15.—Analysis of water of land drainage, and of water used for irrigation .. .. .	£2.
„ 16.—Determination of nitric acid in a sample of water .. .. .	£1.

N.B.—*The above Scale of Charges is not applicable to the case of persons commercially engaged in the Manufacture or Sale of any Substance sent for Analysis.*

The Address of the Consulting Chemist of the Society is, Dr. AUGUSTUS VOELCKER, F.R.S., 11, Salisbury Square, London, E.C., to which he requests that all letters and parcels (postage and carriage paid) should be directed.

By order of the Council,  
H. M. JENKINS, *Secretary.*

## INSTRUCTIONS FOR SELECTING AND SENDING SAMPLES FOR ANALYSIS.

**ARTIFICIAL MANURES.**—Take a large handful of the manure from three or four bags, mix the whole on a large sheet of paper, breaking down with the hand any lumps present, and fold up in tinfoil, or in oil silk, about 3 ozs. of the well-mixed sample, and send it to 11, SALISBURY SQUARE, FLEET STREET, E.C., by post: or place the mixed manure in a small wooden or tin box, which may be tied by string, but must not be sealed, and send it by post. If the manure be very wet and lumpy, a larger boxful, weighing from 10 to 12 ozs., should be sent either by post or railway.

Samples not exceeding 4 ounces in weight may be sent by post, by attaching two penny postage stamps to the parcel.

Samples not exceeding 8 ounces, for three postage stamps.

Samples not exceeding 12 ounces, for four postage stamps.

The parcels should be addressed: DR. AUGUSTUS VOELCKER, 11, SALISBURY SQUARE, FLEET STREET, LONDON, E.C., and the address of the sender or the number or mark of the article be stated on parcels.

The samples may be sent in covers, or in boxes, bags of linen or other materials. No parcel sent by post must exceed 12 ozs. in weight, 1 foot 6 inches in length, 9 inches in width, and 6 inches in depth.

**SOILS.**—Have a wooden box made 6 inches long and wide, and from 9 to 12 inches deep, according to the depth of soil and subsoil of the field. Mark out in the field a space of about 12 inches square; dig round in a slanting direction a trench, so as to leave undisturbed a block of soil with its subsoil from 9 to 12 inches deep; trim this block or plan of the field to make it fit into the wooden box, invert the open box over it, press down firmly, then pass a spade under the box and lift it up, gently turn over the box, nail on the lid and send it by goods or parcel train to the laboratory. The soil will then be received in the exact position in which it is found in the field.

In the case of very light, sandy, and porous soils, the wooden box may be at once inverted over the soil and forced down by pressure, and then dug out.

**WATERS.**—Two gallons of water are required for analysis. The water, if possible, should be sent in glass-stoppered Winchester half-gallon bottles, which are readily obtained in any chemist and druggist's shop. If Winchester bottles cannot be procured, the water may be sent in perfectly clean new stoneware spirit-jars surrounded by wickerwork. For the determination of the degree of hardness before and after boiling, only one quart wine-bottle full of water is required.

**LIMESTONES, MARLS, IRONSTONES, AND OTHER MINERALS.**—Whole pieces, weighing from 3 to 4 ozs., should be sent enclosed in small linen bags, or wrapped in paper. Postage 2*d.*, if under 4 ounces.

**OILCAKES.**—Take a sample from the middle of the cake. To this end break a whole cake into two. Then break off a piece from the end where the two halves were joined together, and wrap it in paper, leaving the ends open, and send parcel by post. The piece should weigh from 10 to 12 ozs. Postage, 4*d.* If sent by railway, one quarter or half a cake should be forwarded.

**FEEDING MEALS.**—About 3 ozs. will be sufficient for analysis. Enclose the meal in a small linen bag. Send it by post.

On forwarding samples, separate letters should be sent to the laboratory, specifying the nature of the information required, and, if possible, the object in view.

H. M. JENKINS, *Secretary.*

## Members' Botanical Privileges.

The Council have provisionally fixed the following rates of Charge for the examination of Plants and Seeds for the *bonâ fide* use of Members of the Society, who are particularly requested, when applying to the Consulting Botanist, to mention the kind of examination they require, and to quote its number in the subjoined Schedule. The charge for examination must be paid to the Consulting Botanist at the time of application, and the carriage of all parcels must be prepaid.

No. 1.—A general opinion as to the genuineness and age of a sample of clover-seed (each sample) .. .. .	5s.
„ 2.—A detailed examination of a sample of dirty or impure clover-seed, with a report on its admixture with seeds of dodder or other weeds (each sample) .. .. .	10s.
„ 3.—A test examination of turnip or other cruciferous seed, with a report on its germinating power, or its adulteration with 000 seed (each sample) .. .. .	10s.
„ 4.—A test examination of any other kind of seed, or corn, with a report on its germinating power (each sample) .. .. .	10s.
„ 5.—Determination of the species of any indigenous British plant (not parasitic), with a report on its habits (each species) .. .. .	5s.
„ 6.—Determination of the species of any epiphyte or vegetable parasite, on any farm-crop grown by the Member, with a report on its habits, and suggestions (where possible) as to its extermination or prevention (each species) .. .. .	10s.
„ 7.—Report on any other form of plant-disease not caused by insects .. .. .	10s.
„ 8.—Determination of the species of a collection of natural grasses indigenous to any district on one kind of soil (each collection) .. .. .	10s.

### INSTRUCTIONS FOR SELECTING AND SENDING SAMPLES.

In sending seed or corn for examination the utmost care must be taken to secure a fair and honest sample. If anything supposed to be injurious or useless exists in the corn or seed, selected samples should also be sent.

In collecting specimens of plants, the whole plant should be taken up, and the earth shaken from the roots. If possible, the plants must be in flower or fruit. They should be packed in a light box, or in a firm paper parcel.

Specimens of diseased plants or of parasites should be forwarded as fresh as possible. Place them in a bottle, or pack them in tin-foil or oil-silk.

All specimens should be accompanied with a letter specifying the nature of the information required, and stating any local circumstances (soil, situation, &c.) which, in the opinion of the sender, would be likely to throw light on the inquiry.

N.B.—*The above Scale of Charges is not applicable in the case of Seedsmen requiring the services of the Consulting Botanist.*

Parcels or letters (Carriage or Postage prepaid) to be addressed to Mr. W. CARRUTHERS, F.R.S., 25, Wellington Street, Islington, London.

H. M. JENKINS, *Secretary.*



# Royal Agricultural Society of England,

1872-3.

## President.

EARL CATHCART.

## Trustees.

Year when Elected.	
1857	BRIDPORT, Viscount, <i>Cumberland Lodge, Windsor, Berkshire.</i>
1850	CHESHAM, Lord, <i>Latimer, Chesham, Bucks.</i>
1861	HOLLAND, EDWARD, <i>Dumbleton Hall, Evesham, Gloucestershire.</i>
1854	MACDONALD, SIR ARCHIBALD KEPPEL, Bt., <i>Woolmer Lodge, Liphook, Hants.</i>
1860	MARLBOROUGH, Duke of, K.G., <i>Blenheim Park, Oxford.</i>
1848	OSSINGTON, Viscount, <i>Ossington, Newark-on-Trent, Notts.</i>
1839	PORTMAN, Lord, <i>Bryanston, Blandford, Dorset.</i>
1856	POWIS, Earl of, <i>Powis Castle, Welshpool, Montgomeryshire.</i>
1858	RUTLAND, Duke of, K.G., <i>Belvoir Castle, Grantham, Leicestershire.</i>
1839	THOMPSON, HARRY STEPHEN, <i>Kirby Hall, York.</i>
1839	TREDEGAR, Lord, <i>Tredegar Park, Newport, Monmouthshire.</i>

## Vice-Presidents.

1861	CATHCART, Earl, <i>Thornton-le-Street, Thirsk, Yorkshire.</i>
1839	CHICHESTER, Earl of, <i>Stanmer Park, Lewes, Sussex.</i>
1867	DEVONSHIRE, Duke of, K.G., <i>Holker Hall, Lancashire.</i>
1847	EGMONT, Earl of, <i>Cowdray Park, Petworth, Sussex.</i>
1847	EVERSLEY, Viscount, <i>Heckfield Place, Winchfield, Hants.</i>
1848	GIBBS, B. T. BRANDRETH, <i>Halfmoon Street, Piccadilly, London, W.</i>
1847	HILL, Viscount, <i>Hawkstone Park, Salop.</i>
1858	KERRISON, SIR EDWARD C., Bart., <i>Brome Hall, Scole, Suffolk.</i>
1839	MILES, SIR WILLIAM, Bart., <i>Leigh Court, Bristol, Somersetshire.</i>
1852	RICHMOND, Duke of, K.G., <i>Goodwood, Chichester, Sussex.</i>
1859	VERNON, Lord, <i>Sudbury Hall, Derby.</i>
1855	WYNN, SIR WATKIN WILLIAMS, Bt., M.P., <i>Wynnstay, Rhuabon, Denbighshire.</i>

## Other Members of Council.

1855	ACLAND, SIR THOMAS DYKE, Bart., M.P., <i>Sprydoncote, Exeter, Devonshire.</i>
1858	AMOS, CHARLES EDWARDS, 5, <i>Cedars Road, Clapham Common, Surrey.</i>
1867	BALDWIN, JOHN, <i>Luddington, Stratford-on-Avon, Warwickshire.</i>
1848	BARNETT, CHARLES, <i>Stratton Park, Biggleswade, Bedfordshire.</i>
1853	BARTHOOPP, NATHANIEL GEORGE, <i>Hacheston, Wickham Market, Suffolk.</i>
1868	BOOTH, THOMAS CHRISTOPHER, <i>Warlaby, Northallerton, Yorkshire.</i>
1863	BOWLY, EDWARD, <i>Siddington House, Cirencester, Gloucestershire.</i>
1861	CANTRELL, CHARLES S., <i>Riding Court, Datchet, Bucks.</i>
1872	CHAPLIN, HENRY, M.P., <i>Blankney Hall, Lincoln.</i>
1866	DAVIES, DAVID REYNOLDS, <i>High Legh Hall, Knutsford, Cheshire.</i>
1861	DENT, J. D., M.P., <i>Ribston Hall, Wetherby, Yorkshire.</i>

Year when Elected.	
1860	DRUCE, JOSEPH, <i>Eynsham, Oxford.</i>
1868	EDMONDS, WILLIAM JOHN, <i>Southrope, Lechlade, Gloucestershire.</i>
1871	EGERTON, HON. WILBRAHAM, M.P., <i>Rostherne Manor, Knutsford, Cheshire.</i>
1872	EXETER, Marquis of, K.G., <i>Burghley House, Stamford, Lincolnshire.</i>
1866	HORNSBY, RICHARD, <i>Spittle Gate, Grantham, Lincolnshire.</i>
1854	HOSKYNs, CHANDOS WREN, M.P., <i>Harewood, Ross, Herefordshire.</i>
1871	JONES, J. BOWEN. <i>Ensdon House, Shrewsbury, Salop.</i>
1867	KESTEVEN, Lord, <i>Caswick, Stamford, Lincolnshire.</i>
1863	KINGSCOTE, Colonel, M.P., <i>Kingscote, Wootton-under-Edge, Gloucestershire.</i>
1848	LAWES, JOHN BENNET, <i>Rothamsted, St. Albans, Herts.</i>
1869	LEEDS, ROBERT, <i>Wicken Farm, Castleacre, Brandon, Norfolk.</i>
1872	LEICESTER, Earl of, <i>Holkham Hall, Wells, Norfolk.</i>
1868	LICHFIELD, Earl of, <i>Shugborough, Staffordshire.</i>
1867	LIDDELL, HON. HENRY GEORGE, M.P., <i>Ravensworth Castle, Durham.</i>
1865	LOPES, SIR MASSEY, Bart., M.P., <i>Maristow, Roborough, Devon.</i>
1871	MCINTOSH, DAVID, <i>Havering Park, Romford, Essex.</i>
1871	MASEN, R. HANBURY, <i>Pendeford, Wolverhampton, Staffordshire.</i>
1846	MILWARD, RICHARD, <i>Thurgarton Priory, Southwell, Notts.</i>
1857	PAIN, THOMAS, <i>The Grove, Basingstoke, Hants.</i>
1861	RANDELL, CHARLES, <i>Chadbury, Evesham, Worcestershire.</i>
1868	RANSOME, ROBERT CHARLES, <i>Ipswich, Suffolk.</i>
1871	RAWLENCE JAMES, <i>Bulbridge, Wilton, Salisbury, Wilts.</i>
1869	RIDLEY, M. WHITE, M.P., <i>Blagdon, Cramlington, Northumberland.</i>
1862	RIGDEN, WILLIAM, <i>Hove, Brighton, Sussex.</i>
1861	SANDAY, WILLIAM, <i>Radcliffe-on-Trent, Notts.</i>
1856	SHUTTLEWORTH, JOSEPH, <i>Hartsholme Hall, Lincoln.</i>
1869	STATTER, THOMAS, <i>Stand Hill, Whitefield, Manchester, Lancashire.</i>
1867	STONE, N. CHAMBERLAIN, <i>Aylestone Hall, Leicester.</i>
1857	TORR, WILLIAM, <i>Aylesby Manor, Great Grimsby, Lincolnshire.</i>
1845	TURNER, GEORGE, <i>Bramford Speke, Exeter, Devonshire.</i>
1871	TURNER, JABEZ, <i>Haddon, Huntingdonshire.</i>
1871	WAKEFIELD, WILLIAM H., <i>Kendal, Westmoreland.</i>
1867	WEBB, JAMES, <i>Spring Hill, Fladbury, Pershore, Worcestershire.</i>
1870	WELBY, WILLIAM EARLE, M.P., <i>Newton House, Folkingham, Lincolnshire.</i>
1871	WELLS, JOHN, <i>Booth Ferry, Howden, Yorkshire.</i>
1861	WELLS, WILLIAM, M.P., <i>Holmewood, Peterborough, Northamptonshire.</i>
1870	WHITEHEAD, CHARLES, <i>Barming House, Maidstone, Kent.</i>
1866	WILSON, Lieut.-Col. FULLER MAITLAND, <i>Stowlangtoft Hall, Bury St. Edmund's, Suffolk.</i>
1865	WILSON, JACOB, <i>Woodhorn Manor, Morpeth, Northumberland.</i>

### Secretary and Editor.

H. M. JENKINS, 12, Hanover Square, London, W.

*Consulting Chemist*—DR. AUGUSTUS VOELCKER, F.R.S., 11, Salisbury Square, E.C.  
*Consulting Botanist*—W. CARRUTHERS, F.R.S., F.L.S., British Museum, W.C.  
*Consulting Veterinary Surgeon*—JAMES BEART SIMONDS, Royal Veterinary College, N.W.  
*Consulting Engineers*—EASTONS & ANDERSON, The Grove, Southwark St., S.E.  
*Seedsmen*—THOMAS GIBBS and Co., Corner of Halfmoon Street, Piccadilly, W.  
*Publisher*—JOHN MURRAY, 50, Albemarle Street, W.  
*Bankers*—THE LONDON AND WESTMINSTER BANK, St. James's Square Branch, S.W.

## STANDING COMMITTEES FOR 1872.

### Finance Committee.

BRIDPORT, Viscount (Chairman).	RANDELL, CHARLES.
DAVIES, D. R.	TORR, WILLIAM.
KINGSCOTE, Colonel, M.P.	

### House Committee.

THE PRESIDENT.	GIBBS, B. T. BRANDRETH.
CHAIRMAN of Finance Committee.	TORR, WILLIAM.
KINGSCOTE, Colonel, M.P.	

### Journal Committee.

THOMPSON, H. S. (Chairman).	MILWARD, RICHARD.
OSSINGTON, Viscount.	RIDLEY, M. WHITE, M.P.
ACLAND, Sir T. DYKE, Bart., M.P.	WELBY, W. E., M.P.
DENT, J. D., M.P.	WELLS, W., M.P.
HOLLAND, EDWARD.	WHITEHEAD, CHARLES.
HOSKYNs, C. WREN, M.P.	WILSON, JACOB.

### Chemical Committee.

WELLS, WILLIAM, M.P. (Chairman).	HOSKYNs, C. WREN, M.P.
LICHFIELD, Lord.	LAWES, J. B.
VERNON, Lord.	VOELCKER, Dr. A.
DAVIES, D. R.	WAKEFIELD, W. H.
DENT, J. D., M.P.	WELBY, W. E., M.P.
EDMONDS, W. J.	WHITEHEAD, CHARLES.
HOLLAND, EDWARD.	WILSON, JACOB.

### Botanical Committee.

WELBY, W. E., M.P. (Chairman).	THOMPSON, H. S.
VERNON, Lord.	TURNER, JABEZ.
DENT, J. D., M.P.	VOELCKER, Dr.
EDMONDS, W. J.	WELLS, W., M.P.
GIBBS, B. T. BRANDRETH.	WHITEHEAD, CHARLES.
JONES, J. BOWEN.	

### Veterinary Committee.

BRIDPORT, Viscount (Chairman).	STATTER, THOMAS.
DENT, J. D., M.P.	THOMPSON, H. S.
GIBBS, B. T. BRANDRETH.	VARNELL, Professor.
LEEDS, ROBERT.	WELLS, JOHN.
RIDLEY, M. WHITE, M.P.	WELLS, WILLIAM, M.P.
SIMONDS, Professor.	WILSON, JACOB.

### Stock-Prizes Committee.

MILWARD, RICHARD (Chairman).	LEEDS, ROBERT.
BRIDPORT, Viscount.	MASFEN, R. H.
BALDWIN, JOHN.	RANDELL, CHAS.
BARTHOPE, NATHANIEL G.	RIGDEN, Wm.
BOOTH, T. C.	SANDAY, Wm.
BOWLY, EDWARD.	TORR, WILLIAM.
DAVIES, D. R.	TURNER, GEORGE.
DENT, J. D., M.P.	WELLS, JOHN.
DRUCE, JOSEPH.	WILSON, JACOB.
GIBBS, B. T. BRANDRETH.	The Stewards of Live Stock.

**Implement Committee.**

BRIDPORT, Viscount.	GIBBS, B. T. BRANDRETH.	SHUTTLEWORTH, JOSEPH.
VERNON, Lord.	HOLLAND, E.	THOMPSON, H. S.
MACDONALD, Sir A. K., Bart.	HORNSBY, RICHARD.	TORR, WILLIAM.
AMOS, C. E.	HOSKYNs, C. WREN, M.P.	WELBY, W. EARLE, M.P.
BOOTH, T. C.	LEEDS, ROBERT.	WELLS, JOHN.
CANTRELL, CHAS. S.	MASFEN, R. H.	WHITEHEAD, CHARLES.
DRUCE, JOSEPH.	RANDELL, CHARLES.	WILSON, JACOB.
EDMONDS, W. J.	RANSOME, R. C.	The Stewards of Imple- ments.
	SANDAY, WILLIAM.	

**General Hull Committee.**

WYNN, SIR WATKIN W. Bart., M.P. (Chairman).	BANNISTER, A.	KINGSCOTE, Col., M.P.
LICHFIELD, Earl of.	BARNETT, C.	LEEDS, ROBERT.
POWIS, Earl of.	BOOTH, T. C.	MILWARD, RICHARD.
BRIDPORT, Viscount.	BOWLY, EDWARD.	RANDELL, CHARLES.
CHESHAM, Lord.	CANTRELL, CHARLES S.	RANSOME, R. C.
KESTEVEN, Lord.	DAVIES, D. R.	RIDLEY, M. W., M.P.
TREDEGAR, Lord.	DENT, J. D., M.P.	SHUTTLEWORTH, JOSEPH.
VERNON, Lord	DRUCE, JOSEPH.	TORR, WILLIAM.
LOPES, Sir MASSEY, Bart., M.P.	EDMONDS, W. J.	WEBB, JAMES.
MACDONALD, Sir A. K., Bart.	GIBBS, B. T. BRANDRETH.	WELLS, WILLIAM, M.P.
	HORNSBY, RICHARD.	WHITEHEAD, CHARLES.
	HOSKYNs, C. WREN, M.P.	WILSON, JACOB.
	HULL, Mayor of.	The STEWARDS.

**Show-Bard Contracts Committee.**

RANDELL, CHARLES (Chairman).	HORNSBY, RICHARD.
BRIDPORT, Viscount.	MILWARD, RICHARD.
VERNON, Lord.	SHUTTLEWORTH, JOSEPH.
AMOS, C. E.	TORR, WILLIAM.
BOOTH, T. C.	WELLS, JOHN.
GIBBS, B. T. BRANDRETH.	

**Committee of Selection.**

THOMPSON, H. S. (Chairman).	KINGSCOTE, Col., M.P.
BRIDPORT, Viscount.	MILWARD, R.
DAVIES, D. R.	RANDELL, CHARLES.
DENT, J. D., M.P.	TORR, WILLIAM.
GIBBS, B. T. BRANDRETH.	WELLS, WILLIAM, M.P.
HOLLAND, E.	

And the Chairmen of the Standing Committees.

**Education Committee.**

HOLLAND, E. (Chairman).	KINGSCOTE, Col., M.P.
LICHFIELD, Earl of.	RANSOME, R. C.
POWIS, Earl of.	WELLS, WILLIAM, M.P.
ACLAND, Sir T. DYKE, Bart., M.P.	VOELCKER, Dr.
DENT, J. D., M.P.	WHITEHEAD, CHARLES.
JONES, J. BOWEN.	

**Cattle Plague Committee.**

THE WHOLE COUNCIL.

\* \* The PRESIDENT, TRUSTEES, and VICE-PRESIDENTS are Members *ex officio* of all Committees.

## Royal Agricultural Society of England.

---

### GENERAL MEETING,

12, HANOVER SQUARE, WEDNESDAY, MAY 22, 1872.

---

#### REPORT OF THE COUNCIL.

SINCE the last General Meeting in December, 57 Members have died, and 144 Members have withdrawn, or have been removed from the list by order of the Council; on the other hand 2 Governors and 157 Members have been elected. The Society, therefore, now consists of

- 71 Life Governors,
- 73 Annual Governors,
- 1655 Life Members,
- 3953 Annual Members,
- 14 Honorary Members,

making a total of 5766. The accounts for the year 1871 have been examined and certified by the auditors and accountants of the Society, and have been published, together with the Wolverhampton Country Meeting account, in the last number of the 'Journal.' The funded capital of the Society remains the same as at the last half-yearly meeting, namely, the permanent fund of 20,000*l.* New Three per Cents., and the Reserve Show-fund of 4112*l.* 7*s.* 8*d.* New Three per Cents. In addition, the sum of 2000*l.* lies on deposit with the Society's bankers, and the balance of the current account on the 1st instant was 1595*l.* 3*s.* 6*d.*, both these sums being available for defraying the expenses of the Cardiff meeting. The Earl of Leicester has been elected a Member of the Council, to fill the vacancy caused by the election of Sir A. K. Macdonald, Bart., as a Trustee. The Cardiff Local Committee are co-operating with the Council to promote the success of the ensuing Country Meeting. In conjunction with the Glamorganshire General Agricultural Society, they have added to the Society's Prize-list offers of Prizes for Hunters and Roadsters, as well as for Agricultural and other classes of Horses, for

Castle-Martin and other breeds of Cattle, for Radnor Sheep, and for Butter and Cheese. Nineteen farms have been entered to compete for the prizes offered by the President, Sir Watkin W. Wynn, Bart., M.P., and by the Society, for the best-managed farms in South Wales and Monmouthshire, and the Judges have reported that after their first visit they were able to select such as were deserving of further examination. The Prize-list in connection with the Cardiff Meeting has been further augmented by the Marquess of Bute and Major Picton Turbervill, who have offered Prizes for Plans of Cottages suitable for agricultural labourers, to cost not more than 220*l.* per pair; and for others suitable for the mineral districts, to cost not more than 90*l.* each. The conditions relating to certain classes of live-stock have been under the careful consideration of the Council, and the following rules have been inserted in the Prize sheet for the Cardiff Meeting, in place of those relating to the same classes which were previously in force:—

No Cow will be eligible for a Prize unless certified either at the date of entry, or between the date of entry and that of the Show, to have had a living Calf; or that the Calf, *if dead*, was born at its proper time—within the twelve months preceding the date of the Show.

No Heifer, except yearlings, entered as in-calf will be eligible for a Prize unless she is certified to have been bulled before the 31st of March in the year of the Show, nor will her owner afterwards receive the Prize until he shall have furnished the Secretary with a further certificate before the 31st of January in the subsequent year, that she produced a living Calf; or that the Calf, *if dead*, was born at its proper time.

No Mare will be eligible for a Prize unless certified either at the date of entry, or between the date of entry and that of the Show, to have had a living Foal; or that the Foal, *if dead*, was born at its proper time, and in the year of the Show; or in the event of a Mare being exhibited *without* a Foal at foot, a certificate shall be produced at the time of entry of her having been served, and the Prize shall be withheld till a certificate be produced of her having produced a foal.

In accordance with the scheme of rotation of districts recently arranged by the Council, the Country Meeting for 1873 will be

held in the district comprising Northumberland, Durham, and the North and East Ridings of Yorkshire. Invitations having been received from the authorities of Darlington, Hull, and Newcastle, a Committee was appointed to inspect and report upon the sites and other accommodation offered by the competing localities. After duly considering the report of this Committee, the Council have decided that the Country Meeting for 1873 shall be held at Hull. The Council have also to announce that the district which has been assigned for the Country Meeting of 1874 comprises the counties of Bedford, Cambridge, Essex, Hertford, Huntingdon, Norfolk, and Suffolk.

The Governors of the Royal Veterinary College have appointed Professor J. B. Simonds to fill the vacancy in the office of Principal of the College, created by the death of Professor Spooner. In consequence of this appointment Professor Simonds is unable to retain the post of Veterinary Inspector to the Royal Agricultural Society. The Council have resolved to make the usual grant to the Royal Veterinary College for the current year, on condition that one of the Professors of the Royal Veterinary College be allowed to act as the Veterinary Inspector of the Society. The Governors of the College have accepted this arrangement and have also agreed to the following schedule of Members' Veterinary Privileges:—

I. *Serious or Extensive Diseases.*—No. 1. Any Member of the Society who may desire professional attendance and special advice in cases of serious or extensive disease among his cattle, sheep, or pigs, will, on application to the Secretary, obtain the services of the Society's Veterinary Inspector, to visit the place where the disease prevails.

No. 2. The remuneration of the Inspector will be 2*l.* 2*s.* each day as a professional fee, and 1*l.* 1*s.* each day for personal expenses; and he will also be allowed to charge the cost of travelling to and from the locality where his services may have been required. The fees and expenses will be a charge against the applicant; but this charge may be reduced or remitted altogether at the discretion of the Council, on such course being recommended to them by the Veterinary Committee.

No. 3. The Inspector, on his return from visiting the diseased stock, will report to the Committee, in writing, the results of his

observations and proceedings, which Report will be laid before the Council.

No. 4. When contingencies arise to prevent a personal discharge of the duties confided to the Inspector, he may, subject to the approval of the Committee, name some competent professional person to act in his stead, who shall receive the same rates of remuneration.

II. *Ordinary or Other Cases of Disease.*—Members may obtain the attendance of the Veterinary Inspector on any case of disease by paying the cost of his visit, which will be at the following rates, viz., 2l. 2s. per diem, and travelling expenses.

III. <i>Consultations without visit.</i> —Personal consultation with the Veterinary Inspector . . . .	5s.
Consultation by letter . . . . .	5s.
Consultation necessitating the writing of three or more letters . . . . .	10s.
Post-mortem examination and report thereon	10s.

A return of the number of applications during each half-year being required from the Veterinary Inspector.

IV. *Admission of Diseased Animals to the Veterinary College, Investigations, Lectures, and Reports.*—No. 1. All Members of the Society have the privilege of sending cattle, sheep, and pigs to the Infirmary of the Royal Veterinary College on the same terms as if they were Members of the College, viz., by paying for the keep and treatment of cattle 10s. 6d. per week each animal, and for sheep and pigs “a small proportionate charge to be fixed by the Principal according to circumstances.”

No. 2. The College has also undertaken to investigate such particular classes of disease, or special subjects connected with the application of the veterinary art to cattle, sheep, and pigs, as may be named by the Council.

No. 3. In addition to the lectures now given by the Professor of Cattle Pathology to the pupils in the Royal Veterinary College, on special occasions the College undertake that one of the Professors shall also deliver such lectures before the Members of the Society, at their house in Hanover Square, as the Council shall desire.

No. 4. The Royal Veterinary College will authorise their Principal to furnish to the Council, quarterly, a detailed report of the cases of cattle, sheep, and pigs treated in the Infirmary,



and also special reports from time to time on any matter of unusual interest, which may come under the notice of the College. The Council have also to announce that they have appointed Professor Simonds Consulting Veterinary Surgeon to the Society.

The Agricultural Education examination was held at the Society's Rooms on the days from Tuesday, April 16th, to Saturday April 20th, inclusive. Three of the candidates who entered at the proper time, and eight of those who entered too late for Prizes, appeared and were examined. Of those who were eligible for prizes, Mr. T. S. Minton has gained a first-class certificate, the life membership of the Society, and the prize for agriculture, in which subject he passed a very good examination. Of the other gentlemen, four passed, namely, Mr. Brown, Mr. Champion, Mr. Ashdown, and Mr. Elwell, who obtained first-class certificates, and the life membership of the Society. All these gentlemen have been students at the Royal Agricultural College at Cirencester.

By order of the Council,

H. M. JENKINS,

Secretary.

# ROYAL AGRICULTURE

DR.

## HALF-YEARLY CASH ACCOUNT

	£.	s.	d.	£.	s.
To Balance in hand, 1st January, 1872:—					
Bankers .. .. .	304	13	5		
Secretary .. .. .	63	12	8		
				368	6
To Income:—					
Dividends on Stock .. .. .	352	12	10		
Subscriptions:—					
Governors' Life-Compositions ..	170	0	0		
Governors' Annual .. .. .	290	0	0		
Members' Life-Compositions ..	677	0	0		
Members' Annual .. .. .	2,933	19	0		
				4,070	19
Journal:—					
Sales .. .. .	80	13	0		
Advertisements .. .. .	47	15	2		
				128	8
Wolverhampton Meeting .. .. .				2	18
Total Income .. .. .	4,554	18	0		
To Cardiff Meeting .. .. .	4,658	9	1	9,213	7
				£9,581	13

### BALANCE-SHEET

	£.	s.	d.	£.	s.
To Capital:—					
Surplus, 31st December, 1872 .. .. .	27,783	10	8		
Surplus of Income over Expenditure during the Half-year:—					
Income .. .. .	4,554	18	0		
Expenditure .. .. .	2,662	8	6		
				1,892	9
				29,676	0
Less half-year's interest and depreciation on Country Meeting Plant .. .. .	210	0	0		
				£29,466	0

# SOCIETY OF ENGLAND.

FROM 1ST JANUARY TO 30TH JUNE, 1872.

CR.

	£.	s.	d.	£.	s.	d.	£.	s.	d.
<b>Expenditure:—</b>									
<b>Establishment:—</b>									
Salaries, Wages, &c. .. .. .	468	12	0						
House Expenses, Rent, Taxes, &c.	407	15	9						
				876	7	9			
<b>Journal:—</b>									
Printing and Stitching .. .. .	376	5	0						
Postage and Delivery .. .. .	161	17	6						
Essays and other Contributions ..	144	10	0						
Woodcuts .. .. .	25	6	0						
Advertisements .. .. .	6	8	6						
				714	7	0			
<b>Chemical:—</b>									
Consulting Chemist's Salary .. ..	150	0	0						
Grant for Investigations .. .. .	200	0	0						
				350	0	0			
<b>Botanical:—Consulting Botanist's Salary .. ..</b>				50	0	0			
Education .. .. .				48	6	6			
Postage and Carriage .. .. .				45	7	5			
Advertisements .. .. .				1	19	0			
Subscriptions paid in error returned .. .. .				5	0	0			
<b>Sundries:—</b>									
Law Charges .. .. .	24	0	6						
Expenses of Inspection Committee	18	6	2						
				42	6	8			
<b>Farm Inspection:—Advertising, &amp;c. .. .. .</b>				30	13	6			
Wolverhampton Meeting .. .. .				498	0	8			
<b>Total Expenditure .. .. .</b>							2,662	8	6
<b>Cardiff Meeting .. .. .</b>							3,098	8	1
<b>Balance in hand, 30th June:—</b>									
Bankers .. .. .	1,799	1	0						
Secretary .. .. .	21	15	7						
				1,820	16	7			
<b>At Deposit with London and Westminster Bank</b>				2,000	0	0			
							3,820	16	7
							£9,581	13	2

30TH JUNE, 1872.

ASSETS.		£.	s.	d.
Cash in hand .. .. .		1,820	16	7
Deposit Account .. .. .		2,000	0	0
New 3 per Cent. Stock 24,112l. 7s. 8d. cost*		22,920	7	1
Books and Furniture in Society's House .. .. .		1,451	17	6
Country Meeting Plant .. .. .		2,590	0	0
		30,783	1	2
Assets at Credit of Cardiff Meeting .. .. .		1,317	1	0
		£29,466	0	2

\* Value at 92½ = £22,302 4s. 4d.

Mem.—The above Assets are exclusive of the amount recoverable in respect of arrears of Subscription to 30th June, 1872, which at that date amounted to 1968l.

Examined, audited, and found correct, this 9th day of September, 1872.

A. H. JOHNSON,  
FRANCIS SHERBORN, } Auditors on behalf of the Society.  
HENRY CANTRELL,

# SHOW AT CARDIFF,

JULY, 1872.

---

## STEWARDS OF THE YARD.

### Stock.

JACOB WILSON (acting for SIR  
WATKIN W. WYNN, BART.,  
M.P., President),  
RICHARD MILWARD,  
ROBERT LEEDS.

### Implements.

C. WREN HOSKYNYS, M.P.,  
W. J. EDMONDS,  
T. C. BOOTH.

### Forage.

J. S. CORBETT.

### Honorary Director of the Show.

B. T. BRANDRETH GIBBS.

---

## JUDGES OF STOCK.

### HORSES.

JOSEPH ATKINSON,  
Major BARLOW,  
H. BIDDELL,  
C. M. NAINBY,  
B. SPRAGGON,  
J. H. WOOD.

### CATTLE.

#### Shorthorns.

H. AYLMER,  
G. DREWRY,  
N. MILNE.

#### Hereford, Welsh, and Castle-Martin Breeds.

R. BACK,  
E. BRADLEY,  
H. HAYWOOD.

#### Devon and other Established Breeds, and Dairy Cattle.

T. POPE,  
R. WOODMAN.

#### Jersey and Guernsey.

H. MIDDLETON,  
H. TAIT.

### SHEEP.

#### Leicester.

E. RILEY,  
W. TORR.

#### Cotswold and Oxfordshire Downs.

R. J. NEWTON,  
W. J. EDMONDS.

#### Lincoln and Long Wool.

C. CLARKE,  
H. MACKINDER.

#### Southdown, Hampshire, and Dorset.

H. FOOKES,  
J. S. TURNER.

#### Shropshire, Cheviot, Radnor and Welsh Mountain.

W. KEMP BOURNE,  
W. HENDERSON,  
R. H. MASFEN.

### PIGS.

J. H. CLARK,  
J. FISHER.

JUDGES OF STOCK—*continued.*

**Inspectors of Shearing.**

H. BONE, J. B. WORKMAN.

**Veterinary Inspectors.**

PROFESSOR BROWN, R. L. HUNT.

---

JUDGES OF BUTTER AND CHEESE.

JOHN DAVIES, JOSEPH FLINT.

---

JUDGES OF IMPLEMENTS.

**Class I.—Portable Steam Engines.**

F. J. BRAMWELL, C.E.,  
W. MENELAUS, C.E.

**Classes VI., VII., & VIII.—Seed Drawers,  
Corn Dressing Machines, and Corn  
Screens.**

F. SHERBORN,  
W. H. CLARE.

**Classes II., III., IV., & V.—Portable  
Steam Threshing and Finishing Ma-  
chines, and Straw or Hay Elevators.**

Major H. V. GRANTHAM,  
JOHN HEMSLEY,  
JOHN HICKEN,  
J. W. KIMBER.

**Miscellaneous Articles.**

HENRY CANTRELL,  
MATTHEW SAVIDGE.

---

JUDGES OF COTTAGE PLANS.

GEORGE HUNT, CHARLES RANDELL, THOMAS SAMPLE.

---

JUDGES OF FARMS.

THOMAS BOWSTEAD, FINLAY DUN, THOMAS JENKINS

## AWARD OF PRIZES.

---

NOTE.—The Judges were instructed, after awarding the Prizes, to designate as the *Reserve Number* one animal in each Class, next in order of merit, if it possessed sufficient for a Prize—in case an animal to which a Prize was awarded should subsequently become disqualified.

*Special Prizes offered by the Cardiff Local Committee are marked thus (\*), and those offered by the Glamorganshire General Agricultural Society thus (†).*

---

### HORSES.

#### *Agricultural Stallions foaled before the 1st of January, 1870.*

THE FYLDE CART-HORSE BREEDING IMPROVEMENT COMPANY, Singleton, Poulton-le-Fylde, Lancashire: FIRST PRIZE, 25*l.*, for "Honest Tom," bay, 7 years-old; bred by Mr. W. Welcher, Snare Hill, Thetford; sire, "Thumper;" dam, "Beauty;" sire of dam, "Emperor."

COATES SHARPLEY, Kelstern Hall, Louth, Lincolnshire: SECOND PRIZE, 15*l.*, for "Le Bon," bay, 4 years-old; bred by Mr. Fullard, Thorney; sire, "Wonder;" sire of dam, "Thumper."

THOMAS STATTER, junior, Stand Hall, Whitefield, Manchester: THIRD PRIZE, 5*l.*, for "Young Champion," chestnut, 5 years-old; breeder unknown; sire, Mr. Stoke's "Champion."

JOHN HOW, Denver, Downham Market, Norfolk: the *Reserve Number*, to "Farmer's Glory," bay, 4 years-old; bred by Mr. Edwards, Waterbeach, Cambridge; sire, "England's Glory;" sire of dam, "Young Drayman."

#### *Agricultural Stallions—Two Years Old.*

FREDERICK THOMAS BRYAN, Humberstone, Leicester: FIRST PRIZE, 20*l.*, for "The Monarch," dark chestnut; bred by Mr. Baumber, Skirbeck, Boston; sire, "Farmer's Glory;" sire of dam, "Robin Hood."

JOSEPH A. SUMMER, Debdale Farm, Mansfield, Notts: SECOND PRIZE, 10*l.*, for "Waxwork," dark grey; bred by himself; sire, "Lucky Boy;" dam, "Depper;" sire of dam, "Young England."

WILLIAM DAVIES, Mardu, Llandrinio, Oswestry: THIRD PRIZE, 5*l.*, for "Montgomeryshire Hero," bay; bred by himself; sire, "Pride of Leighton;" dam, "Ranger;" sire of dam, "Brown Stout."

GEORGE JONES, Stow, Downham Market, Norfolk: the *Reserve Number*, to "Lyon," dark brown; bred by himself; sire, "Heart of Oak;" dam, "Lightsome."

*Clydesdale Stallions foaled before the 1st of January, 1870.*

- ROBERT ORANGE, Bedlington, Morpeth, Northumberland: FIRST PRIZE, 25*l.*, for "Conqueror," dark grey, 6 years-old; bred by the late Mr. J. Lilburn, Preston, North Shields; sire, "Young Glancer;" dam, "Beauty;" sire of dam, "Young Conqueror."
- EDWARD and ALFRED STANFORD, Eatons, Ashurst, Steyning, Hurstpierpoint, Sussex: SECOND PRIZE, 15*l.*, for "The Duke," brown, 5 years-old; bred by the Duke of Hamilton, Hamilton, N.B.; sire, "Sir Walter Scott;" dam, "The Belle;" sire of dam, "Lothian Tom."
- THOMAS STATTER, junior, Stand Hall, Whitefield, Manchester: THIRD PRIZE, 5*l.*, for "Young Bobby Burns," bay, 5 years-old; breeder unknown.

*Clydesdale Stallions—Two Years Old.*

- GEORGE and WILLIAM H. BOTHAM, Wexham Court, Slough, Bucks: FIRST PRIZE, 20*l.*, for "Bucks Hero," bay; bred by Mr. W. H. Botham; sire, "The Don;" dam, "Highland Lass;" sire of dam, "Briton."
- THOMAS STATTER, junior, Stand Hall, Whitefield, Manchester: SECOND PRIZE, 10*l.*, for "Sir Walter Scott," black; bred by himself; sire, "Sir Robert Bruce;" dam, "Jet."

*Suffolk Stallions foaled before the 1st of January, 1870.*

- CHARLES BOBY, Alton Hall, Stutton, Ipswich, Suffolk: FIRST PRIZE, 25*l.*, for "Royal Prince," chestnut, 6 years-old; bred by Mr. C. Frost, Wherstead, Ipswich; sire, Boby's "Conqueror."
- WILLIAM BYFORD, The Court, Glemsford, Suffolk: SECOND PRIZE, 15*l.*, for "Volunteer," chestnut, 5 years-old; bred by Mr. L. Wrinch, Birch Hall, Walton, Essex; sire, Walton's "Warrior;" sire of dam, Catlin's "Duke."

*Suffolk Stallions—Two Years Old.*

- CHARLES BOBY, Alton Hall, Stutton, Ipswich, Suffolk: FIRST PRIZE, 20*l.*, for his chestnut; bred by himself; sire, "Royal Prince;" dam, "Moggey."

*Thoroughbred Stallions, suitable for getting Hunters.*

- JAMES MOFFAT, Kirklington Park, Carlisle, Cumberland: FIRST PRIZE, 50*l.*, for "Laughing Stock," bay, 13 years-old; bred by Sir C. Monks, Bart., Belsea Castle, Morpeth; sire, "Stockwell;" dam, "Gaiety;" sire of dam, "Touchstone."
- JOHN REES, Llanboidy, Whitland, Carmarthenshire: SECOND PRIZE, 25*l.*, for "Christmas Carol," brown, 10 years-old; breeder unknown; sire, "Rataplan;" dam, "Mistletoe;" sire of dam, "Melbourne."
- MAJOR J. SIMPSON BALLARD, The Verlands, Cowbridge, Glamorganshire: THIRD PRIZE, 10*l.*, for "Reinfrid," bay, aged; breeder unknown; sire, "Newminster;" dam, "Marchioness D'Eu;" sire of dam, "Magpie."
- WILLIAM TAYLOR SHARPE, Baumber Park, Horncastle, Lincolnshire: the Reserve Number, to "Suffolk," brown, 7 years-old; bred by Baron Rothschild, Mentmore, Leighton Buzzard; sire, "North Lincoln;" dam, "Protection;" sire of dam, "Defence."

*Stallions, above 14 hands, but not exceeding 15 hands 2 inches, suitable for getting Hackneys.*

BENJAMIN BALDERSTON, Mount Pleasant, Sibsey, Boston, Lincolnshire: **FIRST PRIZE, 20*l.***, for "Norfolk Hero," dark brown, 6 years-old; bred by Mr. Mason, Wereham, Norfolk; sire, "Perfection;" sire of dam, "Wonder."

JAMES LOCKHART, Culmington, Bromfield, Salop: **SECOND PRIZE, 10*l.***, for "Dick Turpin," dark bay, 5 years-old; bred by himself; sire, "Prescription;" dam, "Peggy;" sire of dam, "Topsail."

JOHN LANGLEY, Shirenewton, Chepstow, Monmouthshire: **THIRD PRIZE, 5*l.***, for "Telegram," dapple grey, 9 years-old; bred by Mr. T. C. Bolton, Shirenewton.

WILLIAM GRIFFITH, Ely Common, Cardiff: the *Reserve Number*, to "Ancient Briton," mottled dun, 13 years-old; bred by the late Mr. D. Griffith, Bonvilstone, Cardiff; sire, "Cymro Bach;" sire of dam, "Railway."

*Pony Stallions, not exceeding 14 hands.*

HENRY ROUNDALL, The Queen's Head Hotel, Otley, Yorkshire: **FIRST PRIZE, 15*l.***, for "Sir George," brown, 5 years-old; bred by Mr. W. Walker, Shadwell, Leeds; sire, "Sportsman;" dam, "Black Bess."

TOM LLEWELLYN BREWER, Dan-y-graig, Newport, Monmouthshire: **SECOND PRIZE, 10*l.***, for "Blue Pill," grey, 5 years-old; bred by Mr. B. Giles, Ludlow; sire, "Prescription;" dam, "Cinder;" sire of dam, "Chanticleer."

*Pony Stallions, not exceeding 13 hands.*

THE MARQUESS OF BUTE, Cardiff Castle: **FIRST PRIZE, 15*l.***, for "Cymro," light chestnut, 3 years-old; bred by himself; sire, "Cymro Bach;" dam, "Welsh Pony."

JOHN ANDREW DOYLE, Plas-Dulas, Abergele, Denbighshire: **SECOND PRIZE, 10*l.***, for "Tramp," bay, 8 years-old; bred by himself; sire, "Young Bantam;" dam, "Gipsy."

*Agricultural Mares in foal, or with foal at foot.*

EDMUND CROWE, Denver, Downham Market, Norfolk: **FIRST PRIZE, 20*l.***, for "Smart," bay, 10 years-old (in foal); bred by Mr. J. Betts, Downham Market; sire, Mr. Dack's "Matchless."

FREDERICK STREET, Harrowden House, Bedford: **SECOND PRIZE, 10*l.***, for "Beauty," roan, 6 years-old (and foal by "King of the Country"); bred by Mr. Granger, Haddenham, Isle of Ely; sire of dam, Tibbit's "Thumper."

JOHN LAMB and J. COOPER BOWSTEAD, Penrith, Cumberland: **THIRD PRIZE, 5*l.***, for their brown, 7 years-old (and foal by "True Briton"); bred by Mr. T. Kitching, Clifton Moor, Penrith; sire, Mr. Robinson's "Farmer's Glory;" sire of dam, Earl of Lonsdale's "Farmer's Glory."

WILLIAM PREEES, Underhill Cottage, Bridgend, Glamorganshire: the *Reserve Number*, to "Lofty," bay, 8 years-old (in foal to "Young King of the Vale"); breeder unknown.

*Clydesdale Mares, in foal or with foal at foot.*

THOMAS STATTER, junior, Stand Hall, Whitefield, Manchester: **FIRST PRIZE, 20*l.***, for "Mrs. Muir," bay, 6 years-old (in foal to "Black Prince"); breeder unknown.



**RICHARD THOMAS**, Upper Court Farm, Margam, Taibach, Glamorganshire : **SECOND PRIZE**, 10*l.*, for "Buntyn," dark bay, 7 years old (and foal by "Young Hero"), bred by himself; sire, "Prince of Wales;" dam, "Jolly."

*Suffolk Mares, in foal or with foal at foot.*

**ROBERT CAPON**, Dennington, Wickham Market, Suffolk : **FIRST PRIZE**, 20*l.*, for "Gyp," chestnut, 9 years-old (and foal by Mr. Garrett's "Cup Bearer"); bred by himself; sire, Mr. Capon's "Duke;" dam, "Gyp the 3rd;" sire of dam, Mr. Wilson's "Goliah."

**JOHN J. STONE**, Scyborwen, Llantrissant, Newport, Monmouthshire : **SECOND PRIZE**, 10*l.*, for "Garnet," chestnut, 5 years-old (in foal to "Lord Suffolk"); bred by himself; sire, "Young Champion;" dam, "Smart."

*Mares in foal, or with foal at foot, suitable for breeding Hunters.*

**WILLIAM S. CARTWRIGHT**, Newport, Monmouthshire : **FIRST PRIZE**, 25*l.*, for "Fairminster," bay, 6 years-old (and foal by "Saunterer"); bred by himself; sire, "Newminster;" dam, "Fairwater;" sire of dam, "Loup-Garou."

**THOMAS FOX**, Avenham Hall, Poulton-le-Fylde, Lancashire : **SECOND PRIZE**, 15*l.*, for "Pink," chestnut, 10 years-old (and foal by "Carbineer"); bred by himself; sire, "Sharston;" sire of dam, "Octavian."

**JOHN THOMAS ROBINSON**, Leckby Palace, Asenby, Thirsk : **THIRD PRIZE**, 5*l.*, for "Go-a-Head," bay, 13 years-old (and foal by "Scandal"); breeder unknown; sire, "Sir William."

**THOMAS WILLIAMS**, Albrightlee, Battlefield, Shrewsbury : the *Reserve Number*, to "Alice," chestnut, 10 years-old (and foal by "De Clare"); bred by the late Mr. Davis, Wem; sire, "Hurworth."

*Mares, above 14 hands, and not exceeding 15 hands 1 inch, in foal, or with foal at foot, suitable for breeding Hackneys.*

**ALEXANDER SHEBBATT**, Holdberry Farm, Occlepitchard, Hereford : **FIRST PRIZE**, 20*l.*, for "Polly," dark chestnut, 13 years-old (and foal by "Wolsey"); bred by the Rev. C. L. Eagles; sire, "Hereford;" dam, "Fanny."

**ALBAN WATTS**, New House, Coity, Bridgend, Glamorganshire : **SECOND PRIZE**, 10*l.*, for "The Rosy Morn," chestnut, aged (and foal by "Loyola"); bred by Major Ballard, The Verlands, Cowbridge; sire, "Morning Herald;" dam, "Rosina;" sire of dam, "Hereford."

**THOMAS TONES**, Cross Lane Head, Bridgnorth, Salop : **THIRD PRIZE**, 5*l.*, for "Judy," grey, 14 years-old (and foal by "Wandering Minstrel"); breeder unknown; sire of dam, "Little Tom."

**THOMAS GODDARD**, The Greenwood, St. Fagans, Cardiff : the *Reserve Number*, to "Finale," bay, 9 years-old (in foal to "Reinfrid"); bred by himself; sire, "Clapham."

*Pony Mares not exceeding 14 hands.*

**WILLIAM COATES**, Scarborough Farm, Winchcombe : **FIRST PRIZE**, 10*l.*, for "Kitty," chestnut, 6 years-old; bred by himself; sire, "Douglas."

**GEORGE SAMUEL WORTHINGTON**, Cardiff : **SECOND PRIZE**, 5*l.*, for "Polly," brown, 7 years-old; breeder unknown.

WILLIAM M. SPENCE, Otley, Yorkshire: the *Reserve Number*, to "Lady Lascelles," dark brown, 5 years-old; bred by himself; sire, "King Brian;" dam, "Bessy."

*Pony Mares not exceeding 13 hands.*

WILLIAM ALLEN, Vaindre Hall, Cardiff: FIRST PRIZE, 10*l.*, for "Jenny," chestnut, 8 years-old; breeder unknown.

RICHARD TRAVELL, Mount Stuart Hotel, Docks, Cardiff: SECOND PRIZE, 5*l.*, for "Polly," bay, 6 years-old; breeder unknown.

THOMAS STATTER, junior, Stand Hall, Whitefield, Manchester: the *Reserve Number*, to "Queen Bee," brown, 6 years-old; breeder unknown.

† *Welsh Ponies not exceeding 13 hands, any age or sex.*

JOHN THOMAS, Church Street, Cardiff: FIRST PRIZE, 10*l.*, for "Minnie," dark chestnut mare, 5 years-old; bred by Mr. Williams, Aberpergwm, Neath; dam, "Mountain Lass;" sire of dam, "Cymro Bach."

HENRY BOWEN, Spring Bank, Cardiff: SECOND PRIZE, 5*l.*, for "Dandy," chestnut gelding, aged; breeder unknown.

WILLIAM ALLEN, Vaindre Hall, Cardiff: the *Reserve Number*, to "Kitty," chestnut mare, 7 years-old; breeder unknown.

*Agricultural Fillies—Two Years old.*

HENRY PURSER, Willington Manor, Bedford: FIRST PRIZE, 15*l.*, for "Honest Lass," bay; bred by Mr. J. L. Curtis, of Chatteris, March, Cambridge-shire; sire, Welcher's "Honest Tom;" dam, "Pink."

EDMUND CROWE, Denver, Downham Market, Norfolk: SECOND PRIZE, 10*l.*, for "Flower," chestnut; bred by himself; sire, "Young England's Glory;" dam, "Smart;" sire of dam, "Matchless."

GEORGE STREET, Maulden, Ampthill, Bedfordshire: THIRD PRIZE, 5*l.*, for his roan; bred by himself; sire, "Young Britain;" dam, "Brown."

SOPHIA MILHOUSE, Sketchley Hall, Hinckley, Leicestershire: the *Reserve Number*, to "Louisa," bay; bred by herself; sire, "Black Prince;" dam, "Bonny."

*Clydesdale Fillies—Two Years old.*

GEORGE HAMPTON, North End, Findon, Washington, Pulborough, Sussex: FIRST PRIZE, 15*l.*, for "Blue Bell," grey; bred by himself; sire, "The Duke;" dam, "Heather Bell."

\* *Hunter Mares or Geldings, up to not less than 15 stones.*

FREDERICK B. JONES, Westhall Court Farm, Cheltenham, Gloucestershire: FIRST PRIZE, 20*l.*, for his brown gelding, 6 years-old; breeder unknown; sire, "Lovett;" sire of dam, "Steamer."

GEORGE WILLIAM GRIFFITHS THOMAS, The Heath, Cardiff, Glamorganshire: SECOND PRIZE, 10*l.*, for "Iris," bay, aged; bred by Mr. Alfred Meirs, Sligo, Ireland; sire, "Arthur."

MAJOR J. SIMPSON BALLARD, The Verlands, Cowbridge, Glamorganshire: THIRD PRIZE, 5*l.*, for "Redwing," bay mare, 5 years-old; bred by himself; sire, "Clapham;" dam, "Duckwing;" sire of dam, "Game Cock."

**THE HON. JOHN JOCELYN BOURKE**, 9, Buckingham Vale, Clifton, Bristol: the *Reserve Number*, to "The Colonel," bay gelding, 6 years-old; bred by himself; sire, "The General;" dam, "Kitt."

*\*Hunter Mares or Geldings, up to not less than 12 stones.*

**ALFRED DARBY**, Stanley Hall, Bridgnorth, Salop: **FIRST PRIZE**, 20*l.*, for "General Hood," dark chestnut gelding, 7 years-old; bred by Mr. F. L. Popham, Littlecote Park, Hungerford; sire, "Star of the West."

**HENRY HOWELL**, Coates, Cirencester, Gloucestershire: **SECOND PRIZE**, 10*l.*, for "Lancer," chestnut gelding, 8 years-old; bred by Mr. F. Day, 4, Rosslyn Villas, Shurdington Road, Cheltenham; sire, Laughbawn.

**FRANCIS EDMUND STACEY**, Llandough Castle, Cowbridge, Glamorganshire: **THIRD PRIZE**, 5*l.*, for "Bianconi," bay gelding, 7 years-old; breeder unknown.

**CHARLES BASIL MANSFIELD**, Llysonen, St. Clears, Carmarthenshire: the *Reserve Number*, to "The Lamb," light bay gelding, 6 years-old; bred by Mr. Evans, Nantgwyn, Newcastle, Cardiganshire; sire, "Compromise;" dam, "Kitty;" sire of dam, "Expense."

*\*Hunter Mares or Geldings—Four Years Old.*

**CHARLES COOKE**, Taddington, Winchcombe, Gloucestershire: **FIRST PRIZE**, 20*l.*, for "Admiral," iron-grey gelding; bred by Captain Somner, Berkeley, Gloucestershire; sire, "The Sharper."

**JAMES MOFFAT**, Kirklington Park, Carlisle: **SECOND PRIZE**, 10*l.*, for "Lady Graham," brown filly; bred by Mr. Pewley, Wardhole Guards, Aspatria; sire, "Laughing Stock;" sire of dam, "Brilliant."

**DAVID HOWELL THOMAS**, Derllys Court, Carmarthen: **THIRD PRIZE**, 5*l.*, for "Policeman," bay gelding; bred by himself; sire, "Detective;" dam, "One Eye;" sire of dam, "Harkaway."

**JAMES WALMSLEY TEASDALE**, Poyerston, Pembroke: the *Reserve Number*, to "Theodore," bay gelding; bred by himself; sire, "Artful;" dam, "Myrtle;" sire of dam, "Langton."

*\*Hunter Mares or Geldings—Three Years Old.*

**J. M. TATTERSALL MUSGRAVE**, Beverley, Yorkshire: **FIRST PRIZE**, 20*l.*, for "Honeycomb," chestnut gelding; breeder unknown; sire "Angelus;" sire of dam, "Canute," or "Little Known."

**THOMAS HORROCKS MILLER**, Singleton, Poulton-le-Fylde, Lancashire: **SECOND PRIZE**, 10*l.*, for "Kettledrum," chestnut gelding; bred by himself; sire, "Kettledrum;" sire of dam, "Sir Harry."

**HENRY GEORGE ALLEN**, 66, St. James's Street, London: **THIRD PRIZE**, 5*l.*, for "Cape Horn," brown gelding; bred by himself; sire, "Cape Fly-away;" dam, "Countess;" sire of dam, "Slane."

**LEWIS JENKINS**, Tynycaid, Bridgend, Glamorganshire: the *Reserve Number*, to "Sawara," chestnut gelding; bred by himself; sire, "Clapham;" dam, "Scott."

*\*Hunter Geldings or Fillies—Two Years Old, by a Thoroughbred Horse.*

**THOMAS HORROCKS MILLER**, Singleton, Poulton-le-Fylde, Lancashire: **FIRST PRIZE**, 10*l.*, for "Singleton," bay gelding; bred by himself; sire, "Carbineer."

- LLEWELLYN and HENRY THOMAS, Tydraw, Llantrithyd, Cowbridge, Glamorganshire: SECOND PRIZE, 5*l.*, for their brown gelding; bred by themselves; sire, "Llandaff;" dam, "Sweetbriar;" sire of dam, "Peppermint."
- RUSSELL SWANWICK, R. A. College Farm, Cirencester, Gloucestershire: the *Reserve Number*, to his bay filly; bred by himself; sire, "Redbourn;" dam, "Brunette."

*\*Hunter Geldings or Fillies—One Year Old, by a Thoroughbred Horse.*

- THOMAS HORROCKS MILLER, Singleton, Poulton-le-Fylde, Lancashire: FIRST PRIZE, 10*l.*, for "Victor," bay gelding; bred by himself; sire, "Carbineer;" dam, "Lady Emily;" sire of dam, "Faugh-a-ballagh."
- JOHN EVANS, Pengam House, Cardiff: SECOND PRIZE, 5*l.*, for "Black Bess," black filly; bred by himself; dam, "Brunette."
- EDWARD and ALFRED STANFORD, Eatons, Ashurst, Steyning, Hurstpierpoint, Sussex: the *Reserve Number*, to "Sabina," brown filly; bred by themselves; sire, "Master Fenton;" dam, "Lady Mary" sire of dam, "Royal William."

*\*Roadster Mares or Geldings, above 14 hands 1 inch, and not exceeding 15 hands.*

- THOMAS GODDARD, The Greenwood, St. Fagans, Cardiff: FIRST PRIZE, 15*l.*, for "Dandy," cream gelding, 6 years-old; bred by himself; sire, "Ancient Briton;" dam, "Fanny."
- BRYAN GEORGE DAVIES COOKE, Colomendy, Mold, Flintshire: SECOND PRIZE, 10*l.*, for "General," 5 years-old, iron-grey gelding (Welsh); bred by Mr. Williams, Flintshire.
- THOMAS STATTER, junior, Stand Hall, Whitefield, Manchester: the *Reserve Number*, to his brown mare, 5 years-old; breeder unknown.

*†Cob Mares or Geldings, above 13 hands and not exceeding 14 hands 1 inch.*

- FRANCIS EDMUND STACEY, Llandough Castle, Cowbridge, Glamorganshire: FIRST PRIZE, 15*l.*, for "Tommy Dodd," brown gelding, 8 years-old; breeder unknown; sire, "Highflyer;" sire of dam, "Comet."
- WILLIAM HARRYS, Canton, Cardiff: SECOND PRIZE, 10*l.*, for "Cwmyro," chestnut gelding, 4 years-old; bred by Mr. D. Prichard, Beaufort, Monmouthshire; sire, "Express."
- WILLIAM NICKS, Greville House, Gloucester: the *Reserve Number*, to "Gaylad," dark chestnut gelding, 6 years-old; breeder unknown.

*\*Agricultural Mares or Geldings—Three Years Old.*

- THOMAS TOWNLEY PARKER, Charnock, Chorley, Lancashire: FIRST PRIZE, 10*l.*, for "Princess," brown filly; bred by Mr. John Linton, Westwick Hall, Cambridge; sire, "Honest Tom;" dam, "Trip."
- JAMES PERRY, Salter's Hall, Claverley, Bridgnorth, Salop: SECOND PRIZE, 5*l.*, for "Captain," chestnut gelding; bred by Mr. T. Wall, Wollaston, Stourbridge; sire, "Champion."
- REES WILLIAM BRIDGWATER, Great Porthamal, Talgarth, Brecon: the *Reserve Number*, to "Matchless," grey mare; bred by himself.

*\*Agricultural Mares or Geldings—Two Years Old.*

- SAMUEL C. PILGRIM**, The Outwoods, Hinckley, Leicestershire: **FIRST PRIZE**, 10*l.*, for his bay gelding; bred by himself; sire, "Royal Conqueror;" dam, "Blossom;" sire of dam, "Ranton Robin."
- THOMAS W. D. HARRIS**, Wootton, Northampton: **SECOND PRIZE**, 5*l.*, for his red roan gelding; bred by Mr. Thomas Longland, Yardley Hastings, Northampton.
- JACOB LEWIS**, Radyr Farm, Cardiff: the *Reserve Number*, to his dark bay gelding; bred by himself; sire, "Sir Robert;" dam, "Darby."

*\*Agricultural Mares or Geldings—One Year Old.*

- FREDERIC STREET**, Harrowden House, Bedford: **FIRST PRIZE**, 10*l.*, for "Diamond," bay filly; bred by Mr. Pestell, Great Staughton, Hunts.
- EDWARD PHILLIMORE**, Prestbury Park Farm, Cheltenham, Gloucestershire: **SECOND PRIZE**, 5*l.*, for "Perfection;" red roan filly; bred by himself; sire, "Hartpur;" dam, "Flower;" sire of dam, "Thumper."

*†Agricultural Geldings or Mares, in pairs—Of any age.*

- CHARLES WILLIAM BRIERLEY**, Rhodes House, Middleton, Manchester: **FIRST PRIZE**, 20*l.*, for "Champion," bay gelding, 6 years-old; breeder unknown: and for "Warwick," chestnut gelding, 7 years-old; bred by Mr. Cook, Leamington.
- CHARLES WILLIAM BRIERLEY**, Rhodes House, Middleton, Manchester: **SECOND PRIZE**, 10*l.*, for "Sensation," grey gelding, 7 years-old; bred by Mr. Tennant, Barlow, Selby; sire, "John Bull;" dam, "Diamond;" and for "Flirt," grey mare, 5 years-old; breeder unknown.
- THOMAS STATTER**, junior, Stand Hall, Whitefield, Manchester: the *Reserve Number*, to "Jet," black mare, 9 years-old: and to "Lassie," bay mare, 7 years-old (Clydesdales); breeders unknown.

*†Draught Mares or Geldings, in pairs—For underground purposes.*

- THOMAS STATTER**, junior, Stand Hall, Whitefield, Manchester: **FIRST PRIZE**, 20*l.*, for "Bobby," brown gelding, 8 years-old: and for "Bonny," brown mare, 7 years-old; breeders unknown.

**CATTLE.***Shorthorns—Bulls above Three Years old.*

- JOHN OUTHWAITE**, Bainesse, Catterick, Yorkshire: **FIRST PRIZE**, 30*l.*, for "Royal Windsor" (29,890), white, 3 years, 5 months, 3 weeks, 5 days-old; bred by Mr. T. Willis, Carperby, Leyburn; sire, "Windsor Fitz Windsor" (25,458); dam, "Royal Lily" by "Fitz Clarence" (14,552); gr. d., "Water Lily," by the "Silkie Laddie" (10,947); g. gr. d., "Lily of the Nile" by "Wilberforce" (9830).
- WILLIAM LINTON**, Sheriff Hutton, York: **SECOND PRIZE**, 20*l.*, for "Lord Irwin," white, 3 years, 5 months, 1 week-old; bred by himself; sire,

"British Hope" (21,324); dam, "Handmaid" by "May Day" (20,383); gr. d., "White Rose" by "Magnus Troil" (14,880); g. gr. d., "Miss Henderson" by "Magnus Troil" (14,880).

JAMES COOPER BOWSTEAD, Hackthorpe Hall, Penrith, Cumberland: **THIRD PRIZE, 15*l.***, for "Flag of Britain" (23,955), white, 5 years, 8 months, 3 weeks, 3 days-old; bred by Mr. W. Torr, Aylesby Manor, Great Grimsby; sire, "Breastplate" (19,337); dam, "Flower of Britain" by "British Prince" (14,197); gr. d., "Flower Lady" by "Vanguard" (10,994); g. gr. d., "Flower Girl" by "Londesboro" (6142).

LIEUT.-COLONEL LOYD LINDSAY, V.C., M.P., Lockinge Park, Wantage, Berks: **FOURTH PRIZE, 10*l.***, for "Lord Napier," roan, 3 years, 7 months, 1 week, 2 days-old; bred by Mr. G. Garne, Churchill Heath, Chipping Norton; sire, "Royal Butterfly 20th" (25,007); dam, "Levity" by "Cambridge Prince Royal" (19,380); gr. d., "Lovely" by "Progression" (16,770).

JOHN COOKE, Ballyneal House, New Ross, Kilkenny, Ireland: the *Reserve Number*, to "St. Ringgan" (27,417), roan, 5 years, 5 months, 2 weeks, 2 days-old; bred by the Hon. G. E. Lascelles, Moor Hill, Harewood, Yorkshire; sire, "Good Fitz" (21,844); dam, "Brenda" by "Gay Monk" (19,831); gr. d., "Moll" by "Hopewell" (10,332); g. gr. d., "Memento" by "Vanguard" (10,994).

*Shorthorns—Bulls above Two and not exceeding Three Years old.*

JOHN LAMB, Burrell Green, Penrith, Cumberland: **FIRST PRIZE, 25*l.***, for "Ignoramus" (28,887), roan, 2 years, 2 months, 2 weeks, 4 days-old; bred by himself; sire, "Earl of Eglington" (23,832); dam, "Lauristina" by "Edgar" (19,680); gr. d., "Laurel" by "Nanwick" (16,635); g. gr. d., "Lilac" by "Sulyman" (12,157).

GEORGE GARNE, Churchill Heath, Chipping Norton, Oxfordshire: **SECOND PRIZE, 15*l.***, for "Earl of Warwickshire 3rd" (28,524), roan, 2 years, 7 months, 3 weeks, 6 days-old; bred by Mr. H. J. Sheldon, Brailes House, Shipston-on-Stour; sire, "Duke of Brailes" (23,724); dam, "Lady Emily 2nd" by "Seventh Duke of York" (17,754); gr. d., "Lady Emily" by "Duke of Bolton" (12,738); g. gr. d., "Eugenie" by "Grey Friar" (9172).

CHARLES WILLIAM BRIERLEY, Rhodes House, Middleton, Manchester: **THIRD PRIZE, 10*l.***, for "Prince Charlie," roan, 2 years, 2 months, 1 week, 2 days-old; bred by Mr. J. Meadows, Thornville, Wexford; sire, "Prince of the Realm" (22,627); dam, "Chintz" by "Fugleman" (14,580); gr. d., "Chance" by "Prince Consort" (16,729); g. gr. d., "Chance" by "Prince Ernest" (7366).

JOSEPH STRATTON, Alton Priors, Marlborough, Wilts: **FOURTH PRIZE, 5*l.***, for "Master Glanville," rich roan, 2 years, 8 months-old; bred by the late Mr. R. Stratton, Burderop, Swindon; sire, "James 1st" (24,202); dam, "Miss Glanville 3rd" by "Buckingham" (15,700); gr. d., "Miss Glanville" by "Waterloo" (11,025); g. gr. d., "Rose Anne" by "Hero of the West" (8150).

RICHARD STRATTON, The Duffryn, Newport, Monmouthshire: the *Reserve Number*, to "Saunterer" (29,934), roan, 2 years, 5 months, 1 week, 2 days-old; bred by the late Mr. R. Stratton, Burderop, Swindon; sire, "James 1st" (24,202); dam, "Vesta" by "Ranger" (24,891); gr. d., "Rosy" by "Speculation" (20,882); g. gr. d., "Matchless 9th" by "The Baronet" (17,088).

*Shorthorns—Yearling Bulls above One and not exceeding Two Years old.*

**WILLIAM LINTON**, Sheriff Hutton, York: **FIRST PRIZE**, 25*l.*, for "Leeman," red and white, 1 year, 7 months, 3 weeks, 1 day-old; bred by himself; sire, "Serjeant-Major" (29,957); dam, "Mushroom" by "Earl Windsor" (17,788); gr. d., "Beauty 2nd" by "Magnus Troil" (14,880); g. gr. d., "Beauty" by "Bates" (12,451).

**ALEXANDER HENRY BROWNE**, Bank House, Acklington, Northumberland: **SECOND PRIZE**, 15*l.*, for "Duke of Aosta," roan, 1 year, 7 months, 3 weeks, 6 days-old; bred by Mr. T. H. Hutchinson, Manor House, Catterick; sire, "K.C.B." (26,492); dam, "Queen of Spain" by "Velasco" (15,443); gr. d., "Ciss" by "Young Hopewell" (14,719); g. gr. d., "Cicely" by "Bellemont" (11,164).

**COLONEL CHARLES TOWNELEY**, Towneley, Burnley: **THIRD PRIZE**, 10*l.*, for "Baron Colling 2nd," red, 1 year, 6 months-old; bred by himself; sire, "Baron Oxford" (23,375); dam, "Lady Butterfly 2nd" by "6th Duke of Airdrie" (19,602); gr. d., "Lady Butterfly" by "Great Mogul" (14,651); g. gr. d., "Red Butterfly" by "Master Butterfly" (13,311).

**COLONEL CHARLES TOWNELEY**, Towneley, Burnley: **FOURTH PRIZE**, 5*l.*, for "Kenelm Butterfly," roan, 1 year, 6 months, 4 days-old; bred by himself; sire, "Baron Oxford" (23,375); dam, "Royal Butterfly's Duchess" by "Royal Butterfly" (16,862); gr. d., "Roan Duchess 2nd" by "Frederick" (11,489); g. gr. d., "Roan Duchess" by "Whittington" (12,299).

**LIEUT.-COL. LOYD LINDSAY**, V.C., M.P., Lockinge Park, Wantage, Berks: the *Reserve Number*, to "Magdala," roan, 1 year, 3 months, 3 weeks, 3 days-old; bred by himself; sire, "Lord Napier" (26,691); dam, "Rossette" by "Costa" (21,487); gr. d., "Rossette" by "Prince of Prussia" (16,752); g. gr. d., "Red Rose" by "Horatio" (10,335).

*Shorthorns—Bull Calves above Six and not exceeding Twelve Months old.*

**EMILY LADY PIGOT**, Branches Park, Newmarket: **FIRST PRIZE**, 15*l.*, for "Rapid," roan, 10 months, 5 days-old; bred by herself; sire, "Bythis" (25,700); dam, "Dame Swift" by "Prince of Buckingham" (27,101); gr. d., "Dame Quickly" by "Velasco" (15,443); g. gr. d., "Barmaid" by "British Prince" (14,197).

**COLONEL CHARLES TOWNELEY**, Towneley, Burnley: **SECOND PRIZE**, 10*l.*, for "Hubback, Jun.," red, little white, 10 months, 2 weeks, 5 days-old; bred by himself; sire, "Baron Hubback" (25,569); dam, "Duchess of Lancaster 5th" by "Inglewood" (20,006); gr. d., "Duchess of Lancaster 2nd" by "Precedent" (11,918); g. gr. d., "Lancaster Belle" by "Louis Napoleon 2nd" (13,259).

**JOHN KERSLEY FOWLER**, Prebendal Farms, Aylesbury, Bucks: **THIRD PRIZE**, 5*l.*, for "Royal Geneva," rich roan, 11 months, 3 weeks, 5 days-old; bred by himself; sire, "King Charming;" dam, "Lady Geneva 2nd" by "Duke of Cumberland" (21,584); gr. d., "Lady Geneva" by "Duke of Geneva" (19,614); g. gr. d. by "Marmaduke" (14,897).

**JOHN WILLIAMS**, The Rectory Farm, Llantrithyd, Cowbridge, Glamorgan-shire: the *Reserve Number*, to "Llantrithyd," roan, 11 months, 2 weeks, 1 day-old; bred by himself; sire, "Blandy;" dam, "The Woman in White" by "Kettledrum;" gr. d., "Rosemary Lady Grey" by "May-fly" (11,813); g. gr. d., "Prettymaid" by "Solway" (7530).

*Shorthorns—Cows above Three Years old.*

ALEXANDER HENRY BROWNE, Bank House, Acklington, Northumberland: **FIRST PRIZE, 20*l.***, for "Primrose," red and white, 3 years, 7 months, 1 week, 2 days-old, in-milk; bred by Mr. L. C. Crisp, Hawkhill, Alnwick; sire, "Prowler" (22,662); dam, "Rose 2nd" by "Peak" (24,733); gr. d., "Napier Rosebud" by "Lord Napier" (14,832); g. gr. d. by "Sam Glen" (10,780).

WILLIAM HENRY HEWETT, Norton Court, Taunton: **SECOND PRIZE, 10*l.***, for "Nelly," white, 3 years, 7 months, 4 days-old, in-calf; bred by himself; sire, "James 1st" (24,202); dam, "Maid of Athens" by "Moonraker" (22,383); gr. d., "Etiquette" by "Tenantry" (13,829); g. gr. d., "Eurydice" by "Red Duke" (8694).

GEORGE GARNE, Churchill Heath, Chipping Norton, Oxfordshire: **THIRD PRIZE, 5*l.***, for "Princess Alexandra," white, 4 years, 1 month, 1 week, 5 days-old; bred by himself, in-milk; sire, "Rex" (24,946); dam, "Princess of Wales" by "Programme" (20,608); gr. d., "Princess Maud" by "Progression" (16,770); g. gr. d., "Princess Alice" by "Tom Painter" (15,423).

CHARLES A. BARNES, Charleywood, Rickmansworth, Herts: the *Reserve Number*, to "English Emily," red, little white, 8 years, 9 months, 2 weeks, 3 days-old, in-milk; bred by the late Mr. R. Sharpe, Courtlands, East Grinstead; sire, "Englishman" (19,701); dam, "Miss Emily" by "Young Duke of Cambridge" (14,433); gr. d., "Young Celia 2nd" by "Lord of the South;" g. gr. d., "Young Celia" by "Lord of the North" (11,743).

*Shorthorns—Heifers, in-milk or in-calf, not exceeding Three Years old.*

HENRY FREDERICK SMITH, Lamwath House, Sutton, Hull: **FIRST PRIZE, 15*l.***, for "Lamwath Violet," white, 2 years, 5 months, 4 weeks-old, in-calf; bred by himself; sire, "Booth's Kinsman" (25,658); dam, "Sweet White Violet" by "Sutler" (23,061); gr. d., "Violet" by "Prince George" (13,510); g. gr. d., "Carnation" by "Leo" (13,150).

COLONEL CHARLES TOWNELEY, Towneley, Burnley, Lancashire: **SECOND PRIZE, 10*l.***, for "Baron Oxford's Duchess," red, 2 years, 10 months, 2 weeks, 1 day-old, in-milk; bred by himself; sire, "Baron Oxford" (23,375); dam, "Duchess of Lancaster 2nd" by "Precedent" (11,918); gr. d., "Lancaster Belle" by "Louis Napoleon 2nd" (13,259); g. gr. d., "The Duchess of Lancaster" by "Duke of Lancaster" (10,929).

JOHN JEFFRIES STONE, Scyborwen, Llantrissant, Newport, Monmouthshire: **THIRD PRIZE, 5*l.***, for "Stuart Duchess 3rd," dark roan, 2 years, 7 months, 2 weeks-old, in-calf; bred by himself; sire, "2nd Duke of Wetherby" (21,618); dam, "Mary Stuart" by "Jason" (14,736); gr. d., "Catty" by "Friar John" (12,905); g. gr. d., "Cathleen" by "Duke of Richmond" (7996).

*Shorthorns—Yearling Heifers above One and not exceeding Two Years old.*

COLONEL CHARLES TOWNELEY, Towneley, Burnley: **FIRST PRIZE, 15*l.***, for "Oxford Beauty," roan, 1 year, 6 months, 3 days-old; bred by himself; sire, "Baron Oxford" (23,375); dam, "British Beauty" by "British Prince" (14,197); gr. d., "Lady Abbess" by "Cardinal" (11,246); g. gr. d., "Zena Gross" by "Sheldon" (8557).

JOSEPH STRATTON, Alton Priors, Marlborough, Wilts: **SECOND PRIZE, 10*l.***



for "Village Rose," red, 1 year, 7 months, 1 week, 3 days-old; bred by the late Mr. R. Stratton; sire, "James 1st" (24,202); dam, "April Rose" by "Warwick" (19,120); gr. d., "March Rose" by "Young Windsor" (17,241); g. gr. d., "Christmas Rose" by "His Highness" (14,708).

**COLONEL CHARLES TOWNELEY**, Towneley: **THIRD PRIZE**, 5*l.*, for "Butterfly's Memento 3rd," red and white, 1 year, 8 months, 2 weeks, 1 day-old; bred by himself; sire, "Baron Oxford" (23,375); dam, "Butterfly's Wing" by "Royal Butterfly 5th" (18,756); gr. d., "Batwing 3rd" by "Holkham" (16,274); g. gr. d., "Batwing" by "Ribblesdale" (7422).

**JOSEPH STRATTON**, Alton Priors, Marlborough: the *Reserve Number*, to "Mabel," rich roan, 1 year, 11 months, 1 day-old, in-calf; bred by the late Mr. R. Stratton, Burderop, Swindon; sire, "James 1st" (24,202); dam, "Miranda" by "Knight of the Lagan" (20,082); gr. d., "Moss Rose 4th" by "Hickory" (14,706); g. gr. d., "Moss Rose" by "Phoenix" (6290).

#### *Shorthorns—Heifer Calves, above Six and under Twelve Months old.*

**R. J. MAXWELL GUMBLETON**, Glanatore, Curryglass, County Waterford, Ireland: **FIRST PRIZE**, 10*l.*, for "Emma Courtoun," roan, 11 months, 1 week, 2 days-old; bred by himself; sire, "Earl of Courtoun" (28,500); dam, "Emma" by "Master Harbinger" (18,352); gr. d., "Emily 2nd" by "Orator" (15,026); g. gr. d., "Emily" by "Roan Duke" (13,603).

**THE REV. WALTER SNEYD**, Keele Hall, Newcastle-under-Lyne, Staffordshire: **SECOND PRIZE**, 5*l.*, for "Hollyberry," red and white, 6 months-old; bred by himself; sire, "Ironmaster" (28,895); dam, "Vivian" by "Admiral" (14,063); gr. d., "Horatia" by "Horrex" (11,591); g. gr. d. by "Earl Stanhope" (5996).

**THOMAS GARNE and SON**, Broadmoor, Northleach: the *Reserve Number*, to "Pink," red, 10 months, 1 week, 5 days-old; bred by themselves; sire, "Royal Benedict" (27,348); dam, "Pink of Fashion" by "Count Gloucester" (23,637); gr. d., "Royal Pink" by "Royal Oak" (16,870); g. gr. d., "Young Pink" by "General Pelissier" (14,605).

#### *Herefords—Bulls above Three Years old.*

**THOMAS FENN**, Stonebrook House, Ludlow, and **JOHN HARDING**, Bicton House, Shrewsbury: **FIRST PRIZE**, 25*l.*, for "Bachelor" (2941), red, white face, 5 years, 2 months, 1 week, 3 days-old; bred by Mr. S. Robinson, The Moor, Kington; sire, "Douglas" (2505); dam, "Spinster" by "Sir Thomas" (2228).

**PHILIP TURNER**, The Leen, Pembridge, Herefordshire: **SECOND PRIZE**, 15*l.*, for "Provost," red, white face, 3 years, 1 week, 1 day-old; bred by himself; sire, "Bachelor" (2941); dam, "Rhodia" by "Subaltern" (2794).

**RICHARD HILL**, Orleton Court, Ludlow, Salop: **THIRD PRIZE**, 5*l.*, for "Stout" (3477), red, white face, 4 years, 2 months, 2 weeks, 4 days-old; bred by Mr. Tudge, Adforton, Leintwardine; sire, "The Earl" (3508); dam, "Barmaid" by "Carbonel" (1525).

**LIEUTENANT-COLONEL ROBERT FEILDEN**, Dulas Court, Hereford: the *Reserve Number*, to "Dulas" (3079), red, white face, 4 years, 3 weeks, 5 days-old; bred by himself; sire, "The Prince of Wales" (2820); dam, "Promise" by "Doctor" (1964).

*Herefords—Bulls above Two and not exceeding Three Years old.*

- JOSEPH EVANS SPENCER, Lancadle, Cowbridge, Glamorganshire: **FIRST PRIZE**, 25*l.*, for "Von Moltke," red, white face, 2 years, 5 months, 2 weeks, 5 days-old; bred by Mr. Warren Evans, Landowlais, Usk, Monmouthshire; sire, "Prince Arthur" (2695); dam, "Dames Violet 3rd" by "Monaughty" (2117).
- EDWARD LESTER, Cefn Ila, Usk, Monmouthshire: **SECOND PRIZE**, 15*l.*, for "Chanter," red, white face, 2 years, 8 months, 3 weeks, 5 days-old; bred by himself; sire, "Chorister" (3021); dam, "Choral" by "The Doctor" (1083).
- RICHARD EDWARDS, Trewern Hall, Welshpool, Montgomeryshire: **THIRD PRIZE**, 5*l.*, for "Emstrey," red, white face, 2 years, 9 months, 1 week, 2 days-old; bred by Mr. Henry Linel, Emstrey, Shrewsbury; sire "Ferriman" by "Bosh."
- REES KEENE, Pencraige, Caerleon, Monmouthshire: the *Reserve Number*, to "Tredegar," red, white face, 2 years, 6 months, 5 days-old; bred by Mr. Warren Evans, Landowlais, Usk; sire, "Prince Arthur" (2695); dam, "Dames Violet 4th" by "Hope" (2573).

*Herefords—Yearling Bulls above One and not exceeding Two Years old.*

- WILLIAM TAYLOR, Showle Court, Ledbury, Herefordshire: **FIRST PRIZE**, 25*l.*, for "The Cheltenham Boy," red, white face, 1 year, 8 months, 4 weeks, 1 day-old; bred by himself; sire, "Triumph the 2nd" (3553); dam, "Beauty" by "Holmer" (2043).
- JOHN HARDING, Bicton, Shrewsbury: **SECOND PRIZE**, 15*l.*, for "Lord Battenhall," red, white face, 1 year, 5 months, 4 weeks-old; bred by himself; sire, "Battenhall" (2406); dam, "Theora" by "Sebastopol" (1381).
- HER MAJESTY THE QUEEN, Windsor Castle: **THIRD PRIZE**, 5*l.*, for "Prince Joachim," red, white face, 1 year, 11 months, 2 weeks, 2 days-old; bred by Her Majesty at Flemish Farm, Windsor; sire, "Prince Leopold;" dam, "Princess Mary" by "Deception."
- WILLIAM TUDGE, Adforton, Leintwardine, Herefordshire: the *Reserve Number*, to "Vespasian," red, white face, 1 year, 9 months, 1 week, 2 days-old; bred by himself; sire, "Claudius" (3025); dam, "Phillis" by "Sir Colin" (2216).

*Herefords—Bull Calves above Six and not exceeding Twelve Months old.*

- THOMAS FENN, Stonebrook House, Ludlow: **FIRST PRIZE**, 10*l.*, for "Cop Hall," red, white face, 11 months, 2 weeks-old; bred by himself; sire, "Severus 2nd" (2747); dam, "Butterfly" by "Symmetry" (2799).
- WILLIAM TUDGE, Adforton, Leintwardine, Herefordshire: **SECOND PRIZE**, 5*l.*, for "Regulus," red, white face, 9 months, 3 weeks, 2 days-old; bred by himself; sire, "Sir Roger;" dam, "Bonnie" by "Carbonel" (1525).
- HER MAJESTY THE QUEEN, Windsor Castle: the *Reserve Number*, to "Marquis of Lorne," red, white face, 10 months, 2 weeks, 2 days-old; bred by Her Majesty at Flemish Farm, Windsor; sire, "Prince George Frederick;" dam, "Princess Mary" by "Ajax."

*Herefords—Cows above Three Years old.*

**WILLIAM BURCHALL PEREN**, Compton House, South Petherton, Somerset: **FIRST PRIZE, 20l.**, for "Ivington Rose," red, white face, 7 years, 10 months, 4 days-old, in-calf; bred by Mr. Thomas Roberts, Ivington Bury, Leominster; sire, "Sir Thomas" (2228); dam, "Red Rose" by "Master Butterfly" (1313).

**THOMAS ROGERS**, Coxall, Brampton Brian, Herefordshire: **SECOND PRIZE, 10l.**, for "Silk 2nd," red, white face, 3 years, 10 months, 1 week, 4 days-old, in-calf; bred by himself; sire, "Battenhall" (2406); dam, "Silk" (1820) by "Interest" (2046).

**RICHARD TANNER**, Frodesley, Dorrington, Salop: **THIRD PRIZE, 5l.**, for "Lady Milton," red, white face, 3 years, 11 months, 3 weeks, 5 days-old, in-calf; bred by the late Mr. J. V. Ashwood, Longden Hall, Wellington, Salop; sire, "Chieftain the 5th" (3018); sire of dam, "Milton" (2114).

**THOMAS FENN**, Stonebrook House, Ludlow: the *Reserve Number*, to "Duchess of Bedford 6th," red, white face, 3 years, 11 months, 1 week, 5 days-old, in-calf; bred by himself; sire, "Severus 2nd" (2747); dam, "Duchess of Bedford" by "Arthur Napoleon" (910).

*Herefords—Heifers in-milk or in-calf, not exceeding Three Years old.*

**THOMAS THOMAS**, St. Hilary, Cowbridge, Glamorganshire: **FIRST PRIZE, 15l.**, for "Sunflower," red, white face, 2 years 11 months, 2 weeks, 3 days-old, in-calf; bred by himself; sire, "Sir John 3rd" (3456); dam, "Curly 2nd" by "Goldfinder 2nd" (959).

**PHILIP TURNER**, The Leen, Pembridge, Herefordshire: **SECOND PRIZE, 10l.**, for "Plum," red, white face, 2 years, 8 months, 3 weeks, 6 days-old, in-calf; bred by himself; sire, "Bachelor" (2941); dam, "Dorcas the 2nd" by "Bolingbroke" (1883).

**THOMAS THOMAS**, St. Hilary, Cowbridge: **THIRD PRIZE, 5l.**, for "Lizzie 2nd," red, white face, 2 years, 10 months, 1 week, 1 day-old, in-calf; bred by himself; sire, "Sir John 3rd" (3456); dam, "Lizzie" by "Goldfinder 2nd" (959).

**THOMAS THOMAS**, St. Hilary, Cowbridge: the *Reserve Number*, to "Countess," red, white face, 2 years, 1 week-old, in calf; bred by himself; sire, "Sir John 3rd" (3456); dam, "Isabella" by "Shamrock" (2750).

*Herefords—Yearling Heifers above One and not exceeding Two Years old.*

**THOMAS THOMAS**, St. Hilary, Cowbridge: **FIRST PRIZE, 15l.**, for "Rosaline," red, white face, 1 year, 11 months, 1 week, 3 days-old; bred by himself; sire, "Sir John the 3rd" (3456); dam, "Fairy" by "Shamrock" (2750).

**JOHN MORRIS**, Town House, Madley, Hereford: **SECOND PRIZE, 10l.**, for "Madeline," red, white face, 1 year, 11 months, 3 weeks, 5 days-old; bred by himself; sire, "Stow" (3478); dam, "Pleasant 2nd" by "Little Tommy" (985).

**THOMAS FENN**, Stonebrook House, Ludlow: **THIRD PRIZE, 5l.**, for "Lady of the Teme," red, white face, 1 year, 10 months, 3 weeks, 6 days-old; bred by himself; sire, "Severus 2nd" (2747); dam, "Victoria" by "Wilson."

WILLIAM BURCHALL PEREN, Compton House, South Petherton, Somerset: the *Reserve Number*, to "Belle of the West," red, white face, 1 year, 11 months, 3 weeks, 5 days-old; bred by himself; sire, "Sir Thomas" (2228); dam, "Miss Stanton" by "Interest" (2046).

*Herefords—Heifer Calves above Six and under Twelve Months old.*

PHILIP TURNER, the Leen, Pembridge: FIRST PRIZE, 10*l.*, for "Ruby," red, white face, 10 months, 3 weeks, 2 days-old; bred by himself; sire, "Bachelor" (2941); dam, "Kathleen" by "Bolingbroke" (1883).

HENRY JAMES BAILEY, Rosedale, Tenbury, Herefordshire: SECOND PRIZE, 5*l.*, for "Lady Alice," red, white face, 6 months, 2 weeks, 3 days-old; bred by himself; sire, "Dauphin 2nd;" dam, "Princess Alice 4th" by "Sir Thomas" (2228).

THOMAS FENN, Stonebrook House, Ludlow: the *Reserve Number*, to "Queen of the Teme," red, white face, 11 months, 1 week, 5 days-old: bred by himself; sire, "Severus 2nd" (2747); dam, "Victoria" by "Wilson."

*Devons—Bulls above Three Years old.*

JAMES DAVY, Flitton Barton, North Molton, Devon: FIRST PRIZE, 25*l.*, for "Duke of Flitton 5th," red, 3 years, 9 months, 3 weeks, 3 days-old; bred by himself; sire, "The President" (904); dam, "Actress" (1749) by "Palmerston" (476).

VISCOUNT FALMOUTH, Tregothnan, Probus, Cornwall: SECOND PRIZE, 15*l.*, for "Jonquil," red, 3 years, 9 months, 3 weeks, 5 days-old; bred by himself; sire, "Sunflower" (937); dam, "Picture the 4th" by "Napoleon" (464).

*Devons—Bulls above Two and not exceeding Three Years old.*

WALTER FARTHING, Stowey Court, Bridgwater, Somersetshire: FIRST PRIZE, 25*l.*, for "Master Harry," red, 2 years, 6 months, 3 weeks, 2 days-old; bred by himself: sire, "Master Arthur; dam, "Lofty" by "Sir Peregrine."

VISCOUNT FALMOUTH, Tregothnan, Probus, Cornwall: SECOND PRIZE, 15*l.*, for "Kingcraft," red, 2 years, 11 months, 2 weeks, 2 days-old; bred by himself; sire, "Sunflower" (937); dam, "Peach" (2905A) by "Young Forester" (759).

VISCOUNT FALMOUTH, Tregothnan, Probus, Cornwall: THIRD PRIZE, 5*l.*, for "Cinnaman," red, 2 years, 11 months, 2 weeks, 6 days-old; bred by himself; sire, "Sunflower" (937); dam, "Cinnaminta" (2572B) by "Protector" (711).

JOHN JACKMAN, Hexworthy, Launceston, Cornwall: the *Reserve Number*, to "Earl of Hexworthy," red, 2 years, 11 months, 3 weeks-old; bred by himself; sire, "Cornish Prince" (807); dam, "Rosebud" (3016) by "Warrior" (749).

*Devons—Yearling Bulls above One and not exceeding Two Years old.*

JAMES DAVY, Flitton Barton, North Molton, Devon: FIRST PRIZE, 25*l.*, for "Duke of Flitton 8th," 1 year, 2 months, 2 weeks, 2 days-old; bred by himself; sire, "Duke of Flitton 4th" (827); dam, "Temptress 2nd" (3070) by "Duke of Cornwall" (820).

JOHN JACKMAN, Hexworthy, Launceston, Cornwall: SECOND PRIZE, 15*l.*, for "Earl of Exeter," red, 1 year, 6 months, 2 weeks-old; bred by himself; sire, "Perfection" (899); dam, "Duchess" (2652) by "Garibaldi" (842).

HER MAJESTY THE QUEEN, Windsor Castle: THIRD PRIZE, 5*l.*, for "Prince Imperial," red, 1 year, 10 months, 2 days-old; bred by Her Majesty at Norfolk Farm, Windsor; sire, "Napier;" dam, "Princess Beatrice" by "Prince Alfred."

VISCOUNT FALMOUTH, Tregothnan, Probus, Cornwall: the *Reserve Number*, to "Gipsy King," red, 1 year, 10 months, 1 week, 1 day-old; bred by himself; sire, "Sunflower" (937); dam, "Cinnaminta" (2572B) by "Protector" (711).

*Devons—Bull Calves above Six and not exceeding Twelve Months old.*

JAMES DAVY, Flitton Barton, North Molton, Devon: FIRST PRIZE, 10*l.*, for "Duke of Flitton 9th," red, 11 months, 3 weeks, 6 days-old; bred by himself; sire, "Duke of Flitton 4th" (827); dam, "Cherry 3rd" (2572) by "Duke of Flitton 2nd" (825).

WALTER FARTHING, Stowey Court, Bridgwater, Somerset: SECOND PRIZE, 5*l.*, for his red, 8 months, 4 weeks, 2 days-old; bred by himself; sire, "Duke of Orleans;" dam, "Lovely" by "Lord Dodington."

JOHN AZARIAH SMITH, Bradford Peverell, Dorchester: the *Reserve Number*, to "Duke of York," red, 8 months, 2 weeks, 1 day-old; bred by himself; sire, "Duke of York;" dam, "Gem" (2723) by "Herculius" (854).

*Devons—Cows above Three Years old.*

JOHN AZARIAH SMITH, Bradford Peverell, Dorchester: FIRST PRIZE, 20*l.*, for "Picture," red, 4 years, 9 months, 1 week, 2 days-old, in-milk; bred by himself; sire, "Augustus" (778); dam, "Picture" by "Constitution" (805).

JAMES DAVY, Flitton Barton, North Molton, Devon; SECOND PRIZE, 10*l.*, for "Tempress 2nd," 3 years, 11 months, 1 week, 3 days-old, in-milk and in-calf; bred by himself; sire, "Duke of Cornwall" (820); dam, "Gold Medal Tempress" (1672) by "Napoleon 3rd" (464).

The REV. AUGUSTUS MORGAN, Machan Rectory, Newport, Monmouthshire: the *Reserve Number*, to his red, about 5 years-old, in-milk; bred by Mr. J. Passmore, Allen Farm, Bishopslympton.

*Devons—Heifers in-milk or in-calf, not exceeding Three Years old.*

JAMES DAVY, Flitton Barton, North Molton, Devon: FIRST PRIZE, 15*l.*, for "Gaylass," red, 2 years, 11 months, 3 weeks, 1 day-old, in-calf; bred by himself; sire, "The President" (904); dam, "Princess Alice 2nd" (2971) by "Duke of Flitton 2nd" (825).

JOHN AZARIAH SMITH, Bradford Peverell, Dorchester: SECOND PRIZE, 10*l.*, for "Picture," red, 2 years, 3 months, 2 weeks, 5 days-old, in-calf; bred by himself; dam, "Picture" by "Augustus" (778).

WALTER FARTHING, Stowey Court, Bridgwater, Somerset: the *Reserve Number*, to his red, 2 years, 9 months, 1 week-old, in-calf; bred by himself; sire, "Duke of Gothelney."

*Devons—Yearling Heifers, above One and not exceeding Two Years old.*

WALTER FARTHING, Stowey Court, Bridgwater, Somerset: **FIRST PRIZE, 15*l.***, for "Fair Rosamond," red, 1 year, 10 months, 2 weeks, 6 days-old; bred by himself; sire, "Sir George;" dam, "Prettymaid" by "St. Audries."

TREVOR LEE SENIOR, of Broughton House, Aylesbury, Bucks: **SECOND PRIZE, 10*l.***, for "Lady Edith," red, 1 year, 11 months, 1 week, 3 days-old; bred by himself; sire, "Stowey;" dam, "Ruby."

JAMES DAVY, Flitton Barton, North Molton: **THIRD PRIZE, 5*l.***, for "Actress the 5th," red, 1 year, 10 months, 1 week, 1 day-old; bred by himself; sire, "Duke of Flitton 4th" (827); dam, "Actress" (1749) by "Palmerston" (476).

JOHN AZARIAH SMITH, Bradford Peverell, Dorchester: the *Reserve Number*, to "Daisey," red, 1 year, 9 months, 2 weeks-old; bred by himself; sire, "Duke of York;" dam, "Daisey" (2621) by "Constitution" (805).

*Devons—Heifer-Calves above Six and under Twelve Months old.*

JOHN AZARIAH SMITH, Bradford Peverell, Dorchester: **FIRST PRIZE, 10*l.***, for "Picture," red, 9 months, 2 weeks-old; bred by himself; sire, "Duke of York;" dam, "Picture" by "Augustus" (778).

TREVOR LEE SENIOR, Broughton House, Aylesbury: **SECOND PRIZE, 5*l.***, for "Lady Maude," red, 7 months, 1 week-old; bred by himself; sire, "Stowey;" dam, "Young Daisey."

JAMES HOWARD BULLER, Downes, Crediton, Devon: the *Reserve Number*, to his red, 10 months, 3 weeks, 3 days-old; bred by himself.

*Jerseys—Bulls above One Year old.*

LORD CHESHAM, Latimer, Chesham, Bucks: **FIRST PRIZE, 10*l.***, for his silver-grey, 1 year, 1 month, 3 weeks-old; bred by Lord Dacre, The Hoo, Welwyn.

WALTER GILBEY, Hargrave Park, Stanstead, Essex: **SECOND PRIZE, 5*l.***, for "Don," dark fawn, 1 year, 2 months-old; breeder unknown.

GEORGE SIMPSON, Wray Park, Reigate: the *Reserve Number*, to "Favorite," silver grey, 1 year, 11 months, 1 week-old; bred by himself; sire, "Banker;" dam, "Wild Eyes" by "Prince."

*Jerseys—Cows above Three Years old.*

WALTER GILBEY, Hargrave Park, Stanstead, Essex: **FIRST PRIZE, 10*l.***, for "Milkmaid," fawn, 5 years, 4 months, 3 weeks-old, in-milk; bred by Mr. G. A. Fuller, the Rookery, Dorking, Surrey; sire, "Jack Weller;" dam, "Grasshopper."

GEORGE SIMPSON, Wray Park, Reigate: **SECOND PRIZE, 5*l.***, for "Duchess," silver grey, 4 years, 4 months, 1 week, 1 day-old, in-milk; bred by himself; sire, "Prince;" dam, "Deerfoot" by "Grand Duke."

GEORGE SIMPSON, Wray Park, Reigate: the *Reserve Number*, to "Wild-Eyes," silver grey, 4 years, 3 months, 3 weeks, 6 days-old, in-calf; bred by himself; sire, "Prince;" dam, "Hyacinth" by "The Young Duke."

*Jerseys—Heifers, in-milk or in-calf, not exceeding Three Years old.*

- GEORGE SIMPSON, Wray Park, Reigate: FIRST PRIZE, 10*l.*, for "Queenie," light grey fawn, 1 year, 7 months, 3 weeks, 5 days-old, in-calf; bred by himself; sire, "Rufus;" dam, "Queen."
- WALTER GILBEY, Hargrave Park, Stanstead, Essex; SECOND PRIZE, 5*l.*, for "Bel," fawn, 2 years, 9 months-old, in-milk; breeder unknown.
- ROBERT RENDLE, Catel Farm, Guernsey: the *Reserve Number*, to "Little Queen," light fawn and white, 2 years, 4 months-old, in-calf; breeder unknown; dam, "Queen Bess."

*Guernseys—Bulls above One Year old.*

- CHARLES LE PAGE, Les Naftiaux, Guernsey: FIRST PRIZE, 10*l.*, for "Billy," red and white, 2 years, 5 months, 2 weeks, 1 day-old; bred by Mr. Henry F. de Putron, Pierre Percée, Guernsey.

*Guernseys—Cows above Three Years old.*

- ROBERT RENDLE, Catel Farm, Guernsey: FIRST PRIZE, 10*l.*, for "Duchess," yellow and white, 6 years, 3 months-old, in-calf; bred by himself; sire, "Sir Robert;" dam, "Lady of the Isle" by "Sir John."
- CHARLES LE PAGE, Les Naftiaux, Guernsey: SECOND PRIZE, 5*l.*, for "Betty," red and white, 5 years, 10 months, 2 weeks, 6 days-old, in-calf; bred by Mr. P. Brouard, La Madeline, Guernsey.
- CHARLES LE PAGE, Les Naftiaux: the *Reserve Number*, to "Moor Hen," fawn and white, 5 years, 1 month-old, in-calf; bred by Mr. T. Moore, St. Peter's, Guernsey.

*Guernseys—Heifers, in-milk or in-calf, not exceeding Three Years old.*

- ROBERT RENDLE, Catel Farm, Guernsey: FIRST PRIZE, 10*l.*, for "Lady Jane," red and white, 2 years, 3 months-old, in-calf; bred by himself; sire, "Duke of the Isles;" dam, "Lady Jane."
- THOMAS B. LE PAGE, St. Andrew's, Guernsey: SECOND PRIZE, 5*l.*, for "Lucy," red and white, 2 years, 5 months-old, in-calf; bred by Mr. J. Henry, Mielles, Vale, Guernsey.
- THE REV. JOSHUA RUNDLE WATSON, La Favorita, Fermain, Guernsey: the *Reserve Number*, to "Ophirie," fawn and white, 2 years, 11 months, 3 days-old, in-calf; bred by Mr. H. Giffard, Braye, Vale, Guernsey; sire, "St. Clair;" dam, "Jeune Jaune."

*Welsh—Bulls Three Years old and upwards.*

- WALTER JENKINS, Glanwern, Talsarn, Cardiganshire: FIRST PRIZE, 15*l.*, for "Aeronian," black (Castle-Martin), 4 years, 4 months, 2 weeks, 6 days-old; bred by Mr. T. Jones, Wernligos, Whitland, Carmarthenshire; dam, "Jolly."
- HENRY DAVIES, Typicca, Dryslwyn, Carmarthenshire: SECOND PRIZE, 10*l.*, for his black (Castle-Martin), 4 years, 2 months-old; bred by himself; dam, "Fancy."

DAVID LEWIS, Walton East, Haverfordwest, Pembrokeshire: the *Reserve Number*, to "Walton," black, 4 years, 8 months, 3 weeks, 3 days-old; bred by Mr. R. H. Harvey, Slade Hall, Haverfordwest; sire, "The Churchland Bull;" dam, "Annie Laurie."

*Welsh—Bulls between Two and Three Years old.*

JAMES BEVAN BOWEN, Llwyngwair, Newport, Pembrokeshire: **FIRST PRIZE**, 15*l.*, for "Black Prince," black, 2 years, 2 months, 3 days-old; bred by Mr. R. H. Harvey, Slade House, Haverfordwest; sire, "Merlin;" dam, "Diana" by "Prince of Wales."

RICHARD HUMPHREYS, Royal Goat Hotel, Beddgelert, Carnarvonshire: **SECOND PRIZE**, 10*l.*, for his black, 2 years, 6 months, 3 weeks-old; bred by himself.

THOMAS HARRIES, Llandilo, Abercowin, Carmarthen: the *Reserve Number*, to "Tom," black (Castle-Martin), 2 years, 3 months, 2 weeks, 5 days-old.

*Welsh—Yearling Bulls.*

JOHN DEVONALD MORSE, Glandawke, St. Clears, Carmarthenshire: **FIRST PRIZE**, 15*l.*, for "Taroo," black (Castle-Martin), 1 year, 10 months-old; bred by Mr. T. Hughes, Hill Farm, Manorbier, Tenby.

MAJOR JOHN HEYWARD HEYWARD, Crosswood, Welshpool: **SECOND PRIZE**, 10*l.*, for "355," dark red, black face (Montgomeryshire), 1 year, 2 months, 4 days-old; bred by himself; sire, "201;" dam, "212" by "71."

MAJOR JOHN HEYWARD HEYWARD, Crosswood: the *Reserve Number*, to "384," dark red, black face (Montgomeryshire), 1 year, 4 months, 2 weeks, 4 days-old; bred by himself; sire, "Walton;" dam, "Pleasant 2nd" by "Walton."

*Welsh—Heifers between Two and Three Years old.*

RICHARD HUMPHREYS, Royal Goat Hotel, Beddgelert, Carnarvonshire: **FIRST PRIZE**, 15*l.*, for his black, 2 years, 1 month, 1 week, 6 days-old, in-calf; bred by himself.

THOMAS EVANS, Llwyngrawys, Cardigan: **SECOND PRIZE**, 10*l.*, for "Laurie," black (Castle-Martin), 2 years, 3 months-old, in-calf; bred by himself; sire, "Benjamin;" dam, "Penllydan" by "King of the Vale."

RICHARD HUMPHREYS, Beddgelert: the *Reserve Number*, to his black, little white, 2 years, 5 months, 1 week, 1 day-old, in-calf; bred by himself.

*Welsh—Yearling Heifers.*

JAMES BEVAN BOWEN, Llwyngwair, Newport, Pembrokeshire: **FIRST PRIZE**, 15*l.*, for "Laurie 3rd," black (Anglesea), 1 year, 2 months, 3 weeks, 6 days-old; bred by himself; sire "Young Cynghordy;" dam, "Laurie 2nd" by "Ap Shenkln."

†*Castle-Martin—Pairs of Cows over Three Years old, in-milk or in-calf.*

WILLIAM BENJAMIN ROBERTS, Loveston, Pembroke: **FIRST PRIZE**, 15*l.*, for "Blossom," black, 5 years, 3 months-old, in-milk; bred by Mr. Leach, Corston House, Pembroke: and for "Mayflower," black, 8 years, 4 months-old, in-calf; bred by Mr. Hurlow, West Pinnar, Pembroke.



HUGH HARRIES, Vaynor, Narberth, Pembrokeshire: SECOND PRIZE, 10*l.*, for "Mary Ann," black, 7 years, 5 months-old, in-milk and in-calf; dam, "Fanny;" and for "Fanny," black, 9 years, 6 months-old, in-milk and in-calf; dam, "Wingole;" both bred by himself.

HENRY DAVIES, Typicca, Dryslwyn, Carmarthenshire: the *Reserve Number*, to "Victoria," black, 8 years, 4 months-old, in-calf: and to "Queen," black, 4 years, 3 months-old, in-calf; both bred by himself.

*Other Established Breeds—Bulls above One Year old.*

LORD SONDES, Elmham Hall, Thetford, Norfolk: FIRST PRIZE, 10*l.*, for his red (Norfolk Polled), 3 years, 1 month, 2 weeks-old; bred by himself.

JEREMIAH J. COLMAN, M.P., Carrow House, Norwich: SECOND PRIZE, 5*l.*, for "Cherry Duke," red (Norfolk Polled), 4 years, 4 months, 1 week, 4 days-old, bred by Mr. S. Wolton, Newbourne Hall, Woodbridge; sire, "Esquire," dam, "Beauty."

*Other Established Breeds—Cows above Three Years old.*

LORD SONDES, Elmham Hall, Thetford, Norfolk: FIRST PRIZE, 10*l.*, for his red (Norfolk Polled), 3 years, 8 months-old, in-milk and in-calf; bred by Mr. B. Brown, Thursford.

RICHARD HEMMING CHAPMAN, Upton, Nuneaton, Warwickshire: SECOND PRIZE, 5*l.*, for "Ivanhoe" (Loughorn), white and coloured, 7 years, 3 months, 2 weeks-old, in-milk; bred by himself; sire, "Old Sparkenhoe," dam, "Fillpail," sire of dam, "Sir Richard Warner."

*Other Established Breeds—Heifers in-milk or in-calf, not exceeding Three Years old.*

LORD SONDES, Elmham, FIRST PRIZE, 10*l.*, for his red (Norfolk Polled), 2 years, 7 months, 2 weeks-old, in-calf; bred by Mr. B. Brown, Thursford.

LORD SONDES, Elmham, SECOND PRIZE, 5*l.*, for his red (Norfolk Polled), 2 years, 4 months-old, in-calf; bred by himself.

RICHARD HEMMING CHAPMAN, Upton, Nuneaton: the *Reserve Number*, to "Rolbright," white and red (Loughorn), 2 years, 3 months, 1 week, 5 days-old, in-calf; bred by himself; sire, "The Spondon Knight," dam, "Daisy;" sire of dam, "Curzon."

*\*Bull, Cow, and their Offspring of any Pure Breed.*

WARREN EVANS, Llandowlais, Usk, Monmouthshire, FIRST PRIZE, 20*l.*, for Hereford bull, "Monaughty 3rd," 4 years, 6 months, 2 weeks, 2 days-old; sire, "Hopeful" (2045); dam, "Nena 3rd:" for cow, "Damsel 3rd," 6 years, 3 months, 1 week, 5 days-old; sire, "Hope" (2573); dam, "Damsel 2nd:" and for calf, 8 months, 2 weeks, 4 days-old; bred by himself.

†*Dairy Cattle—Pairs of Cows over Three Years and Eight Months old, in-milk.*

JOHN WILLIAMS, Llantrithyd, Cowbridge, Glamorganshire: FIRST PRIZE, 15*l.*, for his roan (Shorthorns), "Blanche," 7 years, 6 months, 3 weeks, 4 days-old; sire, "Duffryn" (19,592); dam, "Blossom;" sire of dam, "Frank"

(17,874): and "Pearl," 5 years, 4 months-old; sire, "Count Fosco" (2363); dam, "Prioress;" sire of dam, "Frank" (17,874); both bred by Mr. J. Garsed, The Moorlands, Cowbridge.

JOSEPH EVAN SPENCER, Lancadale, Cowbridge: SECOND PRIZE, 10*l.*, for his red, white face (Herefords), "Beauty," 9 years, 4 months, 3 weeks, 5 days-old; bred by the late Mr. J. Parlow, Sufton, Hereford; sire, "Shamrock 2nd" (2210); dam, "Prettypaid;" sire of dam, "Sovereign" (1472): and "Princess of Wales," 5 years, 2 weeks, 6 days-old; bred by himself; sire, "Shylock" (2755); dam, "Countess;" sire of dam, "Clipper" (1178).

WILLIAM BRADBURN, Wednesfield, Wolverhampton: THIRD PRIZE, 5*l.*, for "Miss Valentine," red and white (Shorthorn), age unknown; bred by Mr. C. Stubbs, Preston Hill, Penkridge; sire, "Huntsman" (21,964); dam, "Duchess of Argyle;" sire of dam, "Hercules" (14,692): and for "Oxley," roan (nearly Shorthorn), age unknown; bred by the late Mr. J. Bickford, Oxley, Wolverhampton.

THOMAS STATTER, junior, Stand Hall: the *Reserve Number*, to his (Ayrshires) "Beauty" and "Buttercup," ages and breeders unknown.

## SHEEP.

### *Leicesters—Shearling Rams.*

THE REV. GEORGE INGE, Thorpe Constantine, Tamworth, Staffordshire: FIRST PRIZE, 20*l.*, for his 1 year, 4 months-old; bred by himself; sire, "T. X."

JOHN BORTON, Barton House, Barton-le-Street, Malton: SECOND PRIZE, 10*l.*, for his 1 year, 3 months-old; bred by himself.

TEASDALE HILTON HUTCHINSON, Manor House, Catterick: THIRD PRIZE, 5*l.*, for his 1 year, 3 months, 2 weeks-old; bred by himself.

JOHN BORTON, Barton House: the *Reserve Number*, to his 1 year, 3 months-old; bred by himself.

### *Leicesters—Rams of any other Age.*

THE REV. GEORGE INGE, Thorpe Constantine, Tamworth: FIRST PRIZE, 20*l.*, for his 3 years, 4 months-old; bred by himself; sire, "T;" dam, "P."

JOHN BORTON, Barton House, Barton-le-Street: SECOND PRIZE, 10*l.*, for his 3 years, 3 months-old; bred by himself.

GEORGE TURNER, Brampford Speke, Exeter, Devonshire: THIRD PRIZE, 5*l.*, for his 2 years, 3 months, 2 weeks-old; bred by himself.

JOHN BORTON, Barton House: the *Reserve Number*, to his 2 years, 3 months-old: bred by himself.

### *Leicesters—Pens of Five Shearling Ewes.*

THE REV. GEORGE INGE, Thorpe Constantine, Tamworth: FIRST PRIZE, 15*l.*, for his 1 year, 4 months-old; bred by himself.

TEASDALE H. HUTCHINSON, Manor House, Catterick, Yorkshire: SECOND PRIZE, 10*l.*, for his 1 year, 3 months, 2 weeks-old; bred by himself.

JOHN BORTON, Barton House, Barton-le-Street, Malton: the *Reserve Number*, to his 1 year, 3 months-old; bred by himself.

*Cotswolds—Shearling Rams.*

THE EXECUTORS of the late THOMAS GILLETT, Kilkenny Farm, Faringdon, Oxfordshire: FIRST PRIZE, 20*l.*, for their 1 year, 4 months-old; bred by themselves.

THOMAS BROWN, Marham Hall Farm, Downham Market: SECOND PRIZE, 10*l.*, for his 1 year, 4 months, 2 weeks-old; bred by himself.

THOMAS BROWN, Marham Hall Farm: THIRD PRIZE, 5*l.*, for his 1 year, 4 months, 2 weeks-old; bred by himself.

THOMAS BROWN, Marham Hall Farm: the *Reserve Number*, to his 1 year, 4 months, 2 weeks-old; bred by himself.

*Cotswolds—Rams of any other Age.*

THOMAS BROWN, Marham Hall Farm: FIRST PRIZE, 20*l.*, for his 3 years, 4 months, 2 weeks-old; bred by himself.

The EXECUTORS of the late THOMAS GILLETT, Kilkenny Farm, [Faringdon: SECOND PRIZE, 10*l.*, for their 2 years, 4 months-old; bred by themselves.

T. BEALE BROWNE, Salperton Park, Andoversford: THIRD PRIZE, 5*l.*, for his 3 years, 3 months-old; bred by himself.

THOMAS BROWN, Marham Hall Farm: the *Reserve Number*, to his 2 years, 4 months 2 weeks-old; bred by himself.

*Cotswolds—Pens of Five Shearling Ewes.*

THOMAS THOMAS, St. Hilary, Cowbridge, Glamorganshire: FIRST PRIZE, 15*l.*, for his 1 year, 3 months, 2 weeks-old; bred by himself.

CHRISTOPHER SPENCER, Gileston, Cowbridge: SECOND PRIZE, 10*l.*, for his 1 year, 3 months, 3 weeks-old; bred by himself.

JAMES WALKER, Northleach, Gloucestershire: THIRD PRIZE, 5*l.*, for his 1 year, 3 months-old; bred by himself.

MARY GODWIN, Troy Farm, Somerton, Deddington, Oxfordshire: the *Reserve Number*, to her 1 year, 3 months, 2 weeks-old; bred by herself.

*\* Cotswolds—Pens of Five Ram Lambs.*

THOMAS THOMAS, St. Hilary, Cowbridge, Glamorganshire: FIRST PRIZE, 15*l.*, for his 4 months-old; bred by himself.

CHRISTOPHER SPENCER, Gileston, Cowbridge: SECOND PRIZE, 10*l.*, for his between 4 and 5 months-old; bred by himself.

JOHN WILLIAMS, Caercady, Cowbridge: the *Reserve Number*, to his 4 months, 1 week-old; bred by himself.

*Lincolns—Shearling Rams.*

WILLIAM and HENRY DUDDING, Panton House, Wragby, Lincolnshire: FIRST PRIZE, 20*l.*, for their 1 year, 3 months, 2 weeks-old; bred by themselves.

ROBERT WRIGHT, Nocton Heath, Lincoln: SECOND PRIZE, 10*l.*, for his 1 year, 4 months-old; bred by himself.

JOHN PEARS, Mere, Lincoln: THIRD PRIZE, 5*l.*, for his 1 year, 4 months-old; bred by himself.

WILLIAM and HENRY DUDDING, Panton House: the *Reserve Number*, to their 1 year, 3 months, 2 weeks-old; bred by themselves.

*Lincolns—Rams of any other Age.*

WILLIAM F. MARSHALL, Branston, Lincoln: FIRST PRIZE, 20*l.*, for his 2 years, 4 months, 2 weeks-old; bred by himself.

ROBERT WRIGHT, Nocton Heath, Lincoln: SECOND PRIZE, 10*l.*, for his 3 years, 4 months-old; bred by himself.

JOHN PEARS, Mere, Lincoln: THIRD PRIZE, 5*l.*, for his 3 years, 4 months-old; bred by himself.

WILLIAM F. MARSHALL, Branston: the *Reserve Number*, to his 2 years, 4 months, 2 weeks-old; bred by himself.

*Lincolns—Pens of Five Shearling Ewes.*

JOHN PEARS, Mere, Lincoln: FIRST PRIZE, 15*l.*, for his 1 year, 4 months-old; bred by himself.

JOHN BYRON, Kirkby Green, Sleaford, Lincolnshire: SECOND PRIZE, 10*l.*, for his 1 year, 4 months-old; bred by himself.

THOMAS GUNNELL, Milton, Cambridge: the *Reserve Number*, to his 1 year, 4 months-old; bred by himself.

*\*Long Wools—Pens of Ten Ewes with their Lambs.*

JOHN WILLIAMS, Caercady, Cowbridge, Glamorganshire: FIRST PRIZE, 10*l.*, for his ages various; bred by himself.

THOMAS WILLIAM DANIEL HARRIS, Wootton, Northampton: SECOND PRIZE, 5*l.*, for his ages various; bred by himself.

*Oxfordshire Downs—Shearling Rams.*

JOHN TREADWELL, Upper Winchendon, Aylesbury, Bucks: FIRST PRIZE, 20*l.*, for his 1 year, 4 months, 2 weeks-old; bred by himself.

A. F. MILTON DRUCE, Twelve Acres, Eynsham: SECOND PRIZE, 10*l.*, for his 1 year, 5 months, 2 weeks-old; bred by himself.

CHARLES HOBBS, Maisey Hampton, Cricklade: THIRD PRIZE, 5*l.*, for his 1 year, 4 months, 2 weeks-old; bred by himself.

JOHN TREADWELL, Upper Winchendon: the *Reserve Number*, to his 1 year, 4 months, 2 weeks-old; bred by himself.

*Oxfordshire Downs—Rams of any other Age.*

GEORGE WALLIS, Old Shifford, Bampton, Faringdon: FIRST PRIZE, 20*l.*, for his 2 years, 5 months, 2 weeks-old; bred by himself.

JOHN TREADWELL, Upper Winchendon, Aylesbury: SECOND PRIZE, 10*l.*, for his 3 years, 4 months, 2 weeks-old; bred by himself.

FREDERICK STREET, Harrowden House, Bedford: THIRD PRIZE, 5*l.*, for his 2 years, 5 months-old; bred by himself.

CHARLES HOWARD, Biddenham, Bedford : the *Reserve Number*, to his 2 years, 4 months, 2 weeks-old ; bred by himself.

*Oxfordshire Downs—Pens of five Shearling Ewes.*

CHARLES HOWARD, Biddenham, Bedford : FIRST PRIZE, 15*l.*, for his 1 year, 4 months, 2 weeks-old ; bred by himself.

A. F. MILTON DRUCE, Twelve Acres, Eynsham, Oxon : SECOND PRIZE, 10*l.*, for his 1 year, 5 months, 2 weeks-old ; bred by himself.

FREDERICK STREET, Harrowden House, Bedford : the *Reserve Number*, to his 1 year, 5 months-old ; bred by himself.

*Southdowns—Shearling Rams.*

WILLIAM RIGDEN, Hove, Brighton, Sussex : FIRST PRIZE, 20*l.*, for his 1 year, 4 months-old ; bred by himself.

WILLIAM RIGDEN, Hove, Brighton : SECOND PRIZE, 10*l.*, for his 1 year, 4 months-old ; bred by himself.

COLONEL R. N. FITZ HARDINGE KINGSCOTE, M.P., Kingscote, Wotton-under-edge, Gloucestershire : THIRD PRIZE, 5*l.*, for his 1 year, 4 months-old ; bred by himself ; sire, Mr. Hart's "No. 14."

H.R.H. THE PRINCE OF WALES, K.G., Sandringham, King's Lynn : the *Reserve Number*, to his 1 year, 4 months-old ; bred by His Royal Highness.

*Southdowns—Rams of any other Age.*

WILLIAM RIGDEN, Hove, Brighton, Sussex : FIRST PRIZE, 20*l.*, for his 2 years, 4 months-old ; bred by himself.

WILLIAM RIGDEN, Hove : SECOND PRIZE, 10*l.*, for his 2 years, 4 months-old ; bred by himself.

LORD WALSINGHAM, Merton Hall, Thetford, Norfolk : THIRD PRIZE, 5*l.*, for "Young Bury St. Edmunds," 2 years, 4 months-old ; bred by the late Lord Walsingham, Merton Home Farm, Thetford.

THE DUKE OF RICHMOND, K.G., Goodwood, Chichester, Sussex : the *Reserve Number*, to his 2 years, 4 months-old ; bred by himself.

*Southdowns—Pens of five Shearling Ewes.*

LORD WALSINGHAM, Merton Hall, Thetford, Norfolk : FIRST PRIZE, 15*l.*, for his 1 year, 4 months-old, bred by himself.

LORD SONDES, Elmham Hall, Thetford, Norfolk : SECOND PRIZE, 10*l.*, for his 1 year, 4 months-old ; bred by himself.

JEREMIAH JAMES COLMAN, M.P., Carrow House, Norwich : THIRD PRIZE, 5*l.*, for his 1 year, 4 months-old ; bred by himself.

H.R.H. THE PRINCE OF WALES, K.G., Sandringham, King's Lynn : the *Reserve Number*, to his 1 year, 4 months-old ; bred by His Royal Highness ; sire, "Joe."

*Shropshires—Shearling Rams.*

LORD CHESHAM, Latimer, Chesham, Bucks : FIRST PRIZE, 20*l.*, for his 1 year, 3 months, 2 weeks-old ; bred by himself ; sire, "No. 8."

W. O. FOSTER, Apley Park, Shifnal, Salop: SECOND PRIZE, 10*l.*, for his 1 year, 3 months, 2 weeks-old; bred by himself; sire, "Young Latimer" by "Fat Back."

JOHN EVANS, Uffington: THIRD PRIZE, 5*l.*, for his 1 year, 3 months, 3 weeks-old; bred by himself: sire, "Hard Lines" by "Cardinal."

SARAH BEACH, The Hattons, Brewood, Staffordshire: the *Reserve Number*, to her 1 year, 4 months-old; bred by herself.

*Shropshires—Rams of any other Age.*

THOMAS MANSELL, Adcott Hall, Baschurch: FIRST PRIZE, 20*l.*, for "Legatee," 2 years, 4 months, 2 weeks-old; bred by himself; sire, "Conservative."

THOMAS MANSELL, Adcott Hall: SECOND PRIZE, 10*l.*, for "Constitution," 2 years, 4 months-old; bred by himself; sire, "Conservative."

SARAH BEACH, The Hattons, Brewood, Stafford: THIRD PRIZE, 5*l.*, for her 2 years, 3 months 2 weeks-old; bred by herself.

LORD CHESHAM, Latimer, Chesham, Bucks: the *Reserve Number*, to "Lizmore," 2 years, 3 months, 2 weeks-old; bred by himself.

*Shropshires—Pens of Five Shearling Ewes.*

JOHN HANBURY BRADBURNE, Pipe Place, Lichfield; FIRST PRIZE, 15*l.*, for his 1 year, 4 months, 2 weeks-old; bred by himself; sire, "Crosswood Hero 2nd."

LORD CHESHAM, Latimer, Chesham: SECOND PRIZE, 10*l.*, for his 1 year, 3 months, 2 weeks-old; bred by himself.

JOHN EVANS, Uffington, Shrewsbury: THIRD PRIZE, 5*l.*, for his 1 year, 3 months-old; bred by himself; sire, "Hard Lines."

SARAH BEACH, The Hattons, Brewood, Staffordshire: the *Reserve Number*, to her 1 year, 4 months-old; bred by herself.

*Hampshire and other Short-wools—Shearling Rams.*

JAMES RAWLENCE, Bulbridge, Wilton, Salisbury: FIRST PRIZE, 20*l.*, for his (Hampshire Down) 1 year, 5 months, 2 weeks-old; bred by himself.

JAMES RAWLENCE, Bulbridge, Wilton: SECOND PRIZE, 10*l.*, for his (Hampshire Down) 1 year, 5 months, 2 weeks-old; bred by himself.

ROBERT COLES, Middleton, Norton Bavent, Warminster: THIRD PRIZE, 5*l.*, for his (Hampshire Down) 1 year, 5 months-old; bred by himself.

ROBERT COLES, Middleton: the *Reserve Number*, to his (Hampshire Down) 1 year, 5 months-old; bred by himself.

*Hampshire and other Short-wools—Rams of any other Age.*

ALFRED MORRISON, Fonthill House, Tisbury: FIRST PRIZE, 20*l.*, for his (Hampshire Down) 2 years, 4 months, 1 week-old; bred by himself.

JAMES RAWLENCE, Bulbridge, Wilton: SECOND PRIZE, 10*l.*, for his (Hampshire Down) 3 years, 5 months, 2 weeks-old; bred by himself.

ALFRED MORRISON, Fonthill House, Tisbury, Wilts: THIRD PRIZE, 5*l.*, for his (Hampshire Down) 2 years, 4 months-old; bred by the late Mr. E. Waters, Stratford-sub-Castle, Salisbury.

**THOMAS CHAPMAN SAUNDERS**, Watercombe, Dorchester: the *Reserve Number*, to his (Hampshire Down) 4 years, 5 months-old; bred by himself.

*Hampshire and other Short-wools—Pens of Five Shearling Ewes.*

**JAMES RAWLENCE**, Bulbridge, Wilton, Salisbury: **FIRST PRIZE**, 15*l.*, for his (Hampshire Down) 1 year, 5 months, 2 weeks-old; bred by himself.

**JAMES RAWLENCE**, Bulbridge, Wilton: **SECOND PRIZE**, 10*l.*, for his (Hampshire Down) 1 year, 5 months, 2 weeks-old; bred by himself.

**THOMAS CHAPMAN SAUNDERS**, Watercombe, Dorchester: the *Reserve Number*, to his 1 year, 5 months, 1 week-old; bred by F. S. Schwann, late of North Houghton Manor, Stockbridge, Hants.

*Dorsets—Shearling Rams.*

**HENRY MAYO**, Cokers Frome, Dorchester, Dorset: **FIRST PRIZE**, 10*l.*, for his 1 year, 6 months, 3 weeks-old; bred by himself.

**HENRY MAYO**, Cokers Frome: **SECOND PRIZE**, 5*l.*, for his 1 year, 7 months-old; bred by himself.

**JAMES CULVERWELL**, Clavelshay, North Petherton, Somerset: the *Reserve Number*, to "Varney," 1 year, 6 months, 2 weeks-old; bred by himself.

*Dorsets—Rams of any other Age.*

**HENRY MAYO**, Cokers Frome, Dorchester, Dorset: **FIRST PRIZE**, 10*l.*, for his 2 years, 6 months, 3 weeks-old; bred by himself.

**HENRY MAYO**, Cokers Frome: the *Reserve Number*, to his 2 years, 6 months, 2 weeks-old; bred by himself.

*Dorsets—Pens of Five Shearling Ewes.*

**HENRY MAYO**, Cokers Frome, Dorchester: **FIRST PRIZE**, 10*l.*, for his 1 year, 6 months, 3 weeks-old; bred by himself.

**HENRY MAYO**, Cokers Frome: **SECOND PRIZE**, 5*l.*, for his 1 year, 7 months-old; bred by himself.

**JAMES CULVERWELL**, Clavelshay, North Petherton, Somerset: the *Reserve Number*, to his 1 year, 6 months, 2 weeks-old; bred by himself.

*Cheviots—Shearling Rams.*

**JOHN ROBSON**, Bymess, Rochester, Northumberland: **FIRST PRIZE**, 10*l.*, for his "Young Model," 1 year, 2 months, 2 weeks-old; bred by himself; sire, "Model."

**JOHN ROBSON**, Bymess, Rochester, Northumberland: **SECOND PRIZE**, 5*l.*, for "Young Square Bit," 1 year, 2 months, 2 weeks-old; bred by himself; sire, "Square Bit."

*Cheviots—Rams of any other Age.*

**ROBERT SHORTREED**, Attonburn, Kelso, N. B.: **FIRST PRIZE**, 10*l.*, for his 2 years, 3 months-old; bred by himself; sire, "Jerry."

**WILLIAM B. BUDDICOM**, Penbedw Hall, Mold, Flintshire: **SECOND PRIZE**, 5*l.*, for his "Eriestam," 2 years, 3 months, 2 weeks-old; bred by Mr. Thomas Welsh, Eriestam, Moffat, N. B.; sire, "Hugh" by "Loggie."

**JOHN ROBSON**, Bymess, Rochester, Northumberland: the *Reserve Number*, to "Reserve Number," 4 years, 2 months, 2 weeks-old; bred by himself; sire, "Harry."

*Cheviots—Pens of Five Shearling Ewes.*

- ROBERT SHORTREED, Attonburn, Kelso, N. B. : FIRST PRIZE, 10*l.*, for his 1 year, 3 months-old ; bred by himself ; sire, "Jerry."
- JOHN ROBSON, Bymess, Rochester, Northumberland : SECOND PRIZE, 5*l.*, for his 1 year, 2 months, 2 weeks-old ; bred by himself.
- WILLIAM B. BUDDICOM, Penbedw Hall, Mold, Flintshire : the *Reserve Number*, to his 3 years, 3 months, 2 weeks-old ; bred by Mr. Thomas Welsh, Eriestam, Moffat, N. B.

*Radnors—Shearling Rams.*

- EDWARD FARR, Pilleth, Knighton, Radnorshire : FIRST PRIZE, 10*l.*, for his 1 year, 3 months-old ; bred by Mr. H. M. Evans, Treburvah, Knighton.

† *Radnors—Rams of any other Age.*

- JOSEPH RAWLE PARAMORE, Preswylfa, Neath, Glamorganshire : FIRST PRIZE, 10*l.*, for his 3 years-old ; breeder unknown.
- EDWARD FARR, Pilleth, Knighton, Radnorshire : SECOND PRIZE, 5*l.*, for his 3 years, 3 months-old ; bred by himself.
- JOSEPH RAWLE PARAMORE : Preswylfa, Neath : the *Reserve Number*, to his aged ; breeder unknown.

† *Radnors—Pens of Five Shearling Ewes.*

- THOMAS DALTON, Crockherbtown, Cardiff : FIRST PRIZE, 10*l.*, for his 4 years, 4 months-old ; bred by Mr. William Wilson, The Bank, Walton, Kingston.
- THOMAS DALTON, Crockherbtown, Cardiff : SECOND PRIZE, 5*l.*, for his 4 years, 4 months-old ; bred by Mr. William Wilson, The Bank, Walton, Kingston.
- EDWARD FARR, Pilleth, Knighton : the *Reserve Number*, to his 4 years, 3 months-old ; bred by Mr. H. M. Evans, Treburvah, Knighton.

*Welsh Mountain—Rams of any Age.*

- HOWELL HARRYS, Crofta, Yestradowen, Cowbridge : FIRST PRIZE, 10*l.*, for his 1 year, 4 months-old ; bred by himself.

## PIGS.

*Large White Breed—Boars above Twelve Months old.*

- JAMES AND FREDERICK HOWARD, Britannia Farms, Bedford : FIRST PRIZE, 10*l.*, for "Victor III.," 2 years, 2 weeks, 6 days-old ; bred by themselves ; sire, "Victor II.," dam, "Beauty," sire of dam, "Hero II."
- RICHARD ELMHIRST DUCKERING, Northorpe, Kirton-Lindsey : SECOND PRIZE, 5*l.*, for "Eighth Cultivator," 2 years, 2 months-old ; bred by himself ; sire, "Seventh Cultivator."
- MATTHEW WALKER, Stockley Park, Anslow, Burton-on-Trent : the *Reserve Number*, to "Victor II.," 4 years, 1 week, 1 day-old ; bred by Messrs. Howard, Bedford ; sire, "Victor I.," dam, "Longville," sire of dam, "Gold Spur."



*Large White Breed—Boars above Six and not exceeding Twelve Months old.*

- PETER EDEN, Cross Lane, Salford, Manchester: FIRST PRIZE, 10*l.*, for "Sailor," 11 months, 1 week, 5 days-old; bred by himself; sire, "Premier;" dam, "Blanche;" sire of dam, "Ranger."
- MATTHEW WALKER, Stockley Park, Anslow, Burton-on-Trent: SECOND PRIZE, 5*l.*, for "Pluto," 9 months, 2 weeks, 5 days-old; bred by himself; sire, "John Bull 2nd;" dam, "Stella;" sire of dam, "Old Joe."
- JOHN WHEELER, Long Compton, Shipston-on-Stour, Warwickshire: the *Reserve Number*, to "Young Sam," 10 months, 3 weeks, 5 days-old; bred by himself; sire, "General;" dam, "Miss Juvenile;" sire of dam, "Admiral."

*Large White Breed—Breeding Sows.*

- PETER EDEN, Cross Lane, Salford, Manchester: FIRST PRIZE, 10*l.*, for "Blanche," 2 years, 9 months-old; bred by himself; sire, "Ranger;" dam, "Formosa."
- JAMES and FREDERICK HOWARD, Britannia Farms, Bedford: SECOND PRIZE, 5*l.*, for "Duchess," 4 years, 1 week, 1 day-old, in-pig; bred by themselves; sire, "Victor I.;" dam, "Longville" sire of dam, "Golden Spur."
- MATTHEW WALKER, Stockley Park, Anslow, Burton-on-Trent: the *Reserve Number*, to "Playmate," 3 years, 10 months-old, in-pig; bred by himself; sire, "King Charming;" dam, "Matchless;" sire of dam, "Old King of the West."

*Large White Breed—Pens of Three Breeding Sow Pigs.*

- RICHARD ELMHIRST DUCKERING, Northorpe, Kirton-Lindsey, Lincolnshire: FIRST PRIZE, 10*l.*, for his 7 months, 1 week, 1 day-old; bred by himself; sire, "Victor."
- CLEMENT R. N. BESWICK-ROYDS, Pyke House, Littleborough, Lancashire: SECOND PRIZE, 5*l.*, for "Rose," "Shamrock," and "Thistle," 7 months, 3 weeks, 5 days-old; bred by himself; sire, "Prince Rupert;" dam, "Rose;" sire of dam, "Hercules."
- PETER EDEN, Cross Lane, Salford, Manchester: the *Reserve Number*, to his 7 months, 2 weeks, 3 days-old; bred by himself; sire, "Victor;" dam, "Lily;" sire of dam, "Ranger."

*Small White Breed—Boars above Twelve Months old.*

- PETER EDEN, Cross Lane, Salford, Manchester: FIRST PRIZE, 10*l.*, for "Peacock," 1 year, 10 months-old; bred by himself; sire, "Young King;" dam, "Sister to Young Prince;" sire of dam, "Old Prince."
- CLEMENT R. N. BESWICK-ROYDS, Pyke House, Littleborough, Lancashire: SECOND PRIZE, 5*l.*, for "Hector," 1 year, 9 months, 2 weeks, 2 days-old; bred by Mr. Peter Eden, Salford; sire, "Young King;" dam, "Sister to Prince."
- PETER EDEN, Cross Lane, Salford: the *Reserve Number*, to "Young Prince," 2 years, 10 months, 2 weeks, 3 days-old; bred by himself; sire, "Old Prince;" dam, "Violet;" sire of dam, "King Lear 1st."

*Small White Breed—Boars above Six and not exceeding Twelve Months old.*

PETER EDEN, Cross Lane, Salford, Manchester: FIRST PRIZE, 10*l.*, for "Mouse," 9 months, 3 weeks, 2 days-old; bred by himself; sire, "Young Prince;" dam, "Minnie Warren;" sire of dam, "Young Prince."

PETER EDEN, Cross Lane, Salford: SECOND PRIZE, 5*l.*, for "Baronet," 10 months, 2 weeks-old; bred by himself; sire, "Young King;" dam, "Jewess;" sire of dam, "Lord Nelson."

THOMAS NICHOLSON, 100, Lowther Street, Groves, York: the *Reserve Number*, to his 10 months, 4 weeks-old; bred by himself.

*Small White Breed—Breeding Sows.*

PETER EDEN, Cross Lane, Salford, Manchester: FIRST PRIZE, 10*l.*, for "Venus," 1 year, 7 months, 2 weeks, 3 days-old; bred by himself; sire, "King Lear 3rd;" dam, "Lancashire Maid;" sire of dam, "British Workman."

WILLIAM and HENRY DUDDING, Panton House, Wragby, Lincolnshire: SECOND PRIZE, 5*l.*, for "Little Queen," 1 year, 10 months-old; bred by Mr. T. Nicholson, Lowther Street, York.

RICHARD ELMHIRST DUCKERING, Northorpe, Kirton-Lindsey, Lincolnshire: the *Reserve Number*, to "Princess," 1 year, 7 months, 1 week, 3 days-old; bred by himself; sire "Comet."

*Small White Breed—Pens of Three Breeding Sow Pigs.*

LORD RENDLESHAM, Rendlesham Hall, Woodbridge, Suffolk: FIRST PRIZE, 10*l.*, for "Three Lilies," 6 months, 3 weeks, 4 days-old; bred by Mr. J. Sawyer, Street Farm, Tunstall, Wickham Market; sire, "Young Tommy Dod;" dam, "Miss Prim;" sire of dam, "Emperor."

GEORGE MUMFORD SEXTON, Wherstead Hall, Ipswich, Suffolk: SECOND PRIZE, 5*l.*, for the "Three Real Teazers," 7 months, 3 weeks, 5 days-old; bred by himself; sire, "Peter."

CLEMENT R. N. BESWICK-ROYDS, Pyke House, Littleborough, Lancashire: the *Reserve Number*, to "The Furies," 6 months, 4 weeks, 1 day-old; bred by himself; sire, "Prince Charlie;" dam, "Young Queen;" sire of dam, "Longback."

*Small Black Breed—Boars above Twelve Months old.*

CLEMENT R. N. BESWICK-ROYDS, Pyke House, Littleborough, Lancashire: FIRST PRIZE, 10*l.*, for "Uncle Tom," 3 years, 3 months, 2 weeks, 1 day-old; bred by Mr. T. Roberts, St. Leven, Penzance; sire, "Tancred;" dam, "Bessie."

GEORGE MUMFORD SEXTON, Wherstead Hall, Ipswich: SECOND PRIZE, 5*l.*, for "Cremorne," 1 year, 4 months, 1 week, 2 days-old; bred by himself; sire, "Adventurer;" dam, "Hannah;" sire of dam, "Gladiator."

GEORGE MUMFORD SEXTON, Wherstead Hall, Ipswich: the *Reserve Number*, to "Queen's Messenger," 1 year, 3 months, 1 week, 4 days-old; bred by himself; sire, "Adventurer;" dam, "Achievement;" sire of dam, "Stockwell."

*Small Black Breed—Boars above Six and not exceeding Twelve Months old.*

GEORGE MUMFORD SEXTON, Wherstead Hall, Ipswich, Suffolk: FIRST PRIZE, 10*l.*, for "Patriarch" 9 months, 1 day-old; bred by himself; sire, "Adventurer;" dam, "Hippia;" sire of dam, "Stockwell."

WILLIAM MORTIMER WARE, Newham House, Helstone, Cornwall: SECOND PRIZE, 5*l.*, for "Steatite," 8 months, 2 weeks, 3 days-old; bred by himself; sire, "Portsmouth;" dam, "Bessie;" sire of dam, "Tancred."

*Small Black Breed—Breeding Sows.*

GEORGE MUMFORD SEXTON, Wherstead Hall, Ipswich, Suffolk: FIRST PRIZE, 10*l.*, for "Maria Louise," 1 year, 7 months, 4 weeks-old; bred by himself; sire, "Adventurer;" dam, "Expectation;" sire of dam, "Negro."

GEORGE MUMFORD SEXTON, Wherstead Hall, Ipswich: SECOND PRIZE, 5*l.*, for "Reine," 1 year, 9 months-old; bred by himself; sire, "Blair Athol;" dam, "Princess of Wales;" sire of dam, "Battersea Prince."

CLEMENT R. N. BESWICK-ROYDS, Pyke House, Littleborough, Lancashire: the *Reserve Number*, to "Topsy," 2 years, 2 months, 2 weeks, 2 days-old, in-pig; bred by Mr. S. G. Stearn, Wickham Market; sire, "Black Tom;" dam, "Fan;" sire of dam, "Negro."

*Small Black Breed—Pens of Three Breeding Sow Pigs.*

GEORGE MUMFORD SEXTON, Wherstead Hall, Ipswich, Suffolk: FIRST PRIZE, 10*l.*, for "What, first again," 7 months, 3 weeks, 3 days-old; bred by himself; sire, "Adventurer;" dam, "Achievement;" sire of dam, "Stockwell."

*Berkshire Breed—Boars above Twelve Months old.*

HEBER HUMFREY, Kingstone Farm, Shrivenham, Berks: FIRST PRIZE, 10*l.*, for "No. 380 M," 1 year, 2 weeks, 2 days-old; bred by himself; sire, "Leamington;" dam, "No. 283 D;" sire of dam, "Rainbow."

THOMAS RADCLIFFE, Cheswell Grange, Newport, Salop: SECOND PRIZE, 5*l.*, for "Dick Turpin," 2 years, 1 week-old; bred by Mr. R. Fowler, Aylesbury; sire, "Tim Whiffler;" dam, "Royal Oxford."

HEBER HUMFREY, Kingstone Farm, Shrivenham: the *Reserve Number*, to "Maple Grove," 2 years, 3 weeks, 4 days-old; bred by himself; sire, "Royal Oak;" dam, "Beauty Bewitched;" sire of dam, "Souse Genteel."

*Berkshire Breed—Boars above Six and not exceeding Twelve Months old.*

The EXECUTORS of the late W. HEWER, Sevenhampton, Highworth, Wilts: FIRST PRIZE, 10*l.*, for their 11 months, 5 days-old; bred by themselves; sire, "Exchange;" dam, "Hope;" sire of dam, "Sennington Lad 5th."

LORD CLERMONT, Ravensdale Park, Newry, Ireland: SECOND PRIZE, 5*l.*, for his 6 months, 2 weeks, 5 days-old; bred by himself; sire, "Disraeli;" dam, "Spencer 2nd;" sire of dam, "Exeter 3rd."

ARTHUR STEWART, Saint Bridge Farm, Gloucester: the *Reserve Number*, to his 9 months, 4 weeks-old; bred by himself; sire, "Sampson;" dam, "Kalvellie I."

*Berkshire Breed—Breeding Sows.*

- RICHARD FOWLER, Broughton Farm, Aylesbury, Bucks: **FIRST PRIZE, 10l.**, for "Royal Princess," 2 years, 6 months, 3 weeks, 2 days-old, in pig; bred by himself; sire, "Tim Whiffler."
- ARTHUR STEWART, Saint Bridge Farm, Gloucester: **SECOND PRIZE, 5l.**, for "Duchess II.," 1 year, 4 months, 3 weeks, 5 days-old, in-pig; bred by himself; sire, "Sampson;" dam, "Kalvellie I."
- NATHANIEL BENJAFIELD, Short's Green Farm, Motcombe, Shaftesbury, Dorset: the *Reserve Number*, to "Princess Beatrice," 1 year, 4 months, 2 weeks, 5 days-old, in-pig; bred by himself; sire, "King Pippin 4th;" dam, "Princess;" sire of dam, "Diamond."

*Berkshire Breed—Pens of Three Breeding Sow Pigs.*

- ARTHUR STEWART, Saint Bridge Farm, Gloucester: **FIRST PRIZE, 10l.**, for his 7 months, 2 weeks, 5 days-old; bred by himself; sire, "Sampson;" dam, "Kalvellie II."
- JOHN BIGGS, Cublington, Leighton Buzzard: **SECOND PRIZE, 5l.**, for his 6 months, 3 weeks, 2 days-old; bred by himself; sire, "Tichborne;" dam, "Beauty;" sire of dam, "Baronet."
- RUSSELL SWANWICK, Royal Agricultural College Farm, Cirencester, Gloucestershire: the *Reserve Number*, to the "Sally Family," 6 months, 3 weeks, 5 days-old; bred by himself; sire, "Othello;" dam, "Sally IV.;" sire of dam, "D boar."

*Other Breeds—Boars.*

- CLEMENT, R. N. BESWICK-ROYDS, Pyke House, Littleborough, Lancashire: **FIRST PRIZE, 10l.**, for "Priam," white, with spots (middle), 1 year, 9 months, 2 weeks, 2 days-old; bred by Mr. P. Eden, Salford, Manchester; sire, "Young Sampson;" dam, "Lancashire Lass."
- RICHARD E. DUCKERING, Northorpe, Kirton-Lindsey: **SECOND PRIZE, 5l.**, for "Wolf," black (Essex), 1 year, 11 months-old; bred by Mr. T. R. Cornish, Wolfsgrrove, Bishopsteignton, Devon.
- FRANCIS HART DYKE, Acomb, York: the *Reserve Number*, to "Ebor" white (middle), 1 year, 10 months-old; bred by himself.

*Other Breeds—Breeding Sows.*

- PETER EDEN, Cross Lane, Salford, Manchester: **FIRST PRIZE, 10l.**, for "Busy Bee," white (middle), 5 years, 5 months, 4 days-old; bred by himself; sire, "King Lear 1st;" dam, "Pride of the Village;" sire of dam, "King Lear 1st."
- PETER EDEN, Cross Lane, Salford: **SECOND PRIZE, 5l.**, for "Flo," white (middle), 2 years, 6 months-old; bred by himself; sire, "Old Prince;" dam, "Countess;" sire of dam, "The Cure."
- RICHARD ELMHIRST DUCKERING, Northorpe, Kirton-Lindsey; the *Reserve Number*, to "Victress," white (Lincoln middle), 2 years, 6 months, 1 week-old; bred by himself; sire, "6th Cultivator."

*Other Breeds—Pens of Three Breeding Sow Pigs.*

- PETER EDEN, Cross Lane, Salford, Manchester: **FIRST PRIZE, 10l.**, for his white (middle), 7 months, 2 weeks, 5 days-old; bred by himself; sire, "Young King;" dam, "Empress;" sire of dam, "King Lear 2nd."

**\* BUTTER.**

*Six Pounds, made up in Pounds.*

- ROBERT CHESHAM, Latimer, Chesham : FIRST PRIZE, 5*l*.  
MARGARET H. DAVID, St. Fagan's Rectory, Cardiff : SECOND PRIZE, 3*l*.  
JOHN JONES, Old Beaupré, Cowbridge : THIRD PRIZE, 2*l*.  
GEORGE CROFTS WILLIAMS, Llanrumney Hall, Cardiff : the *Reserve Number*.
- 

**\* CHEESE, THE PRODUCE OF 1872.**

*Over 6 inches thick, and weighing in the aggregate not less than One Hundredweight.*

- GEORGE GIBBONS, Tunley Farm, Bath : FIRST PRIZE, 10*l*.  
WILLIAM DUDLESTON, New Lodge, Dorrington, Newport, Salop : SECOND PRIZE, 5*l*.  
ELIZA BENJAFIELD, Froglin Farm, Motcombe, Shaftesbury : THIRD PRIZE, 2*l*.  
ANDREW PRICE, Bagley, Ellesmere : the *Reserve Number*.

*Under 6 inches thick, and weighing in the aggregate not less than 56 Pounds.*

- GEORGE HARRIS, Court House Farm, Lower Cam, Dursley : FIRST PRIZE, 10*l*.  
JOHN SMITH, Nupdown Farm, Thornbury, Gloucestershire : SECOND PRIZE, 5*l*.  
MARIA BARRS, Odstone Hall, Atherstone : THIRD PRIZE, 2*l*.  
THOMAS CULVERWELL, Llwynbelig, Cowbridge : the *Reserve Number*.
- 

**FARM PRIZES.**

*For the Two Best Managed Farms in South Wales and Monmouthshire.*

- WILLIAM SAVOURS POWELL, Eglwysnunydd, Taibach : FIRST PRIZE, a Silver Cup, value 100*l*.; the gift of Sir Watkin W. Wynn, Bart., M.P., President of the Society.  
VALENTINE PARSONS, Slough Farm, Caerwent, Chepstow : SECOND PRIZE, 50*l*.; given by the Society.
- 

**IMPLEMENTS.**

*Portable Steam Engines (not Self-Moving) not exceeding 8-Horse Power.*

- CLAYTON and SHUTTLEWORTH, Lincoln : FIRST PRIZE, 40*l*., for their 8-Horse-Power Single-Cylinder Portable Steam Engine, improved and manufactured by themselves.  
The READING IRONWORKS COMPANY (Limited), Reading : SECOND PRIZE, 20*l*., for their 8-Horse-Power Portable Steam Engine, invented, improved, and manufactured by themselves.

DAVEY, PAXMAN, and Co., Colchester, Essex: HIGHLY COMMENDED, for their 8-Horse-Power Portable Engine, improved and manufactured by themselves.

MARSHALL, SONS, and Co. (Limited), Gainsborough: HIGHLY COMMENDED, for their Portable Steam Engine, invented, improved, and manufactured by themselves.

BROWN and MAY, Devizes: COMMENDED, for their 8-Horse-Power Portable Steam Engine, manufactured by themselves.

*Combined Portable Threshing and Finishing Machines, to be worked by Steam.*

MARSHALL, SONS, and Co.: FIRST PRIZE, 40*l.*, for their Threshing and Finishing Dressing Machine, invented, improved, and manufactured by themselves.

RANSOMES, SIMS, and HEAD, Ipswich: SECOND PRIZE, 20*l.*, for their Portable Double-Blast Finishing Threshing Machine, invented, improved, and manufactured by themselves.

CLAYTON and SHUTTLEWORTH: HIGHLY COMMENDED, for their Combined Portable Double-Blast Threshing and Finishing Machine, invented, improved, and manufactured by themselves.

RUSTON, PROCTOR, and Co., Lincoln: COMMENDED, for their Combined Threshing and Finishing Machine, invented, improved, and manufactured by themselves.

*Combined Portable Threshing Machines, to be worked by Steam.*

CLAYTON and SHUTTLEWORTH: FIRST PRIZE, 40*l.*, for their Combined Portable Threshing Machine, invented, improved, and manufactured by themselves.

RANSOMES, SIMS, and HEAD: SECOND PRIZE, 20*l.*, for their Single-Blast Steam Threshing Machine, invented, improved, and manufactured by themselves.

MARSHALL, SONS, and Co., Gainsborough: HIGHLY COMMENDED, for their Threshing and Dressing Machine, invented, improved, and manufactured by themselves.

WILLIAM TASKER, and SONS, Andover: HIGHLY COMMENDED, for their Portable Combined Threshing Machine, invented, improved, and manufactured by themselves.

HOLMES and SON, Norwich: COMMENDED, for their Combined Portable Threshing Machine, invented, improved, and manufactured by themselves.

PHILIP and HENRY PHILIP GIBBONS, Wantage: COMMENDED, for their Portable Combined Steam Threshing Machine, invented, improved, and manufactured by themselves.

*Straw Elevators, to be worked by Steam.*

MARSHALL, SONS, and Co.: FIRST PRIZE, 10*l.*, for their Straw Elevator, invented by Hayes, Stamford; improved and manufactured by themselves.

CLAYTON and SHUTTLEWORTH: SECOND PRIZE, 5*l.*, for their Portable Straw Elevator, improved, and manufactured by themselves.

**WILLIAM TASKER and SONS**: HIGHLY COMMENDED, for their 4-Wheel Elevators, invented, improved, and manufactured by themselves.

*Straw or Hay Elevators, to be worked by Horse-Power.*

**CLAYTON and SHUTTLEWORTH**: FIRST PRIZE, 10*l.*, for their Portable Elevator for stacking straw, hay, or sheaf-corn, improved and manufactured by themselves.

**STEPHEN LEWIN**, Poole, Dorset: SECOND PRIZE, 5*l.*, for his Stacking Machine, invented, improved, and manufactured by himself.

**WILLIAM TASKER and SONS**: HIGHLY COMMENDED, for their 2-Wheel Balance Elevator, invented, improved, and manufactured by themselves.

**R. and J. REEVES and SON**, Bratton, Westbury, Wilts: HIGHLY COMMENDED, for their Hay, Corn, or Straw Elevator, invented by W. Andrews, Melksham; improved and manufactured by themselves.

*Seed Drawers.*

**HOLMES and SON**: THE PRIZE of 10*l.* for their Seed Drawer, with Dressing Apparatus, invented, improved, and manufactured by themselves.

**R. HUNT and J. A. TAWELL**, Earls Colne, Halstead, Essex: HIGHLY COMMENDED, for their Steam-Power Clover and Trefoil Seed Drawing Machine, invented by Reuben Hunt, and manufactured by themselves.

*Corn-Dressing Machines.*

**J. COOCH**, Harlestone, Northamptonshire: FIRST PRIZE, 15*l.*, for her Corn-Dressing Machine, invented by the late J. Cooch; improved and manufactured by herself.

**THOMAS BAKER**, Compton, Newbury: SECOND PRIZE, 10*l.*, for his Corn-Dressing and Winnowing Machine, invented, improved, and manufactured by himself.

**W. N. NICHOLSON and SON**, Newark, Notts: THIRD PRIZE, 5*l.*, for their Winnower and Corn-Dressing Machine, invented, improved, and manufactured by themselves.

**W. RAINFORTH and SON**, Brayford Head, Lincoln: HIGHLY COMMENDED, for their Winnowing and Corn-Dressing Machine, improved and manufactured by themselves.

**CORBET and CHIPCHASE**, Shrewsbury: COMMENDED, for their Corn-Dressing Machine, invented and improved by themselves; manufactured by T. Corbet.

**JOHN BAKER**, Wisbeach; COMMENDED, for his Corn-Dressing and Screening Machine, invented, improved, and manufactured by himself.

*Corn Screens.*

**ROBERT BOBY**, Bury St. Edmunds: FIRST PRIZE, 10*l.*, for his Self-Cleaning Corn Screen, invented, improved, and manufactured by himself.

**RICHARD HORNSBY and SONS**, Grantham: SECOND PRIZE, 5*l.*, for their Adjustable Corn Screen, invented, improved, and manufactured by themselves.

**COLEMAN and MORTON**, Chelmsford: HIGHLY COMMENDED, for their Adjustable

Rotary Corn Screen and Seed Separator, invented by W. Wyatt; improved and manufactured by themselves.

W. RAINFORTH and SON: HIGHLY COMMENDED, for their Adjustable Rotary Corn Screen, invented and manufactured by themselves.

THOMAS CORBETT, Shrewsbury: COMMENDED, for his Corn Screen, invented, improved, and manufactured by himself.

PENNEY and Co. (Limited), Lincoln: COMMENDED, for their Adjustable Rotary Corn Screen, invented, improved, and manufactured by themselves.

---

### SILVER MEDALS.

E. R. and F. TURNER, Ipswich, for Hartwell's Patent Variable Expansion Governor.

BENJAMIN REID, and Co., Aberdeen, for their Patent Disc Broadcast Sowing-Machine, with Road Carriage, invented by J. H. Sams.

BARFORD and PERKINS, Peterborough, for their Patent Adjusting Screws for setting Square Threshing or other Machines.

CLAYTON and SHUTTLEWORTH, for Wilder's Patent Self-Feeding Apparatus, adapted for Threshing Machines.

RANSOMES, SIMS, and HEAD, for their Patent Drum, adapted for Threshing Machines.

MARSDEN and Co., Leeds, for Blake's Patent Stone Breaker.

LAWRENCE and Co., 14, St. Mary Axe, London, E.C., for their Patent Capillary Refrigerator for Cooling Milk.

---



# AGRICULTURAL EDUCATION.

*Examination Papers, 1872.*

---

## EXAMINATION IN AGRICULTURE.

MAXIMUM NUMBER OF MARKS, 200. PASS NUMBER, 100.

*Tuesday, April 16th, from 10 a.m. till 1 p.m.*

1. State the implements required for use on a farm of 500 acres of light land, 100 acres being pasture, worth to rent 50s. per acre, the remainder arable.
2. For such a farm as described in question No. 1, state the live stock which would be required, and the numbers of each kind.
3. What would be the number of labourers required to be employed on such a farm as described in No. 1 question?
4. Describe the best course of cropping to be pursued on the arable part of such farm as the one mentioned in No. 1 question.
5. Describe the best course of cropping to be pursued on an arable farm of 1000 acres of strong clay land.
6. Supposing steam-power to be employed on such a farm as the one described in question No. 5, what implement or implements should you prefer to use in the summer for preparing land for wheat? And what for breaking up the stubbles in autumn?
7. Still considering the farm as described in question No. 5, give a description of the cultivation required in the spring for lent corn and for green crops, presuming such land to be perfectly clean.
8. Following question No. 7, describe the cultivation necessary, presuming the land to be full of couch, grass or otherwise foul.
9. Given 100 acres of swedes, 15 tons being grown to the acre. How many feeding sheep would be required to eat them off in 22 weeks? Each sheep to have daily  $\frac{1}{2}$  lb. of cake and some chaff.
10. A six-horse-power engine and a thrashing machine being used, state the number of persons required to be employed in thrashing a wheat rick and their different duties, the straw being stacked on the spot.

*Afternoon, vivâ voce examination commencing at 2 o'clock.*

---

EXAMINATION IN CHEMISTRY.

MAXIMUM NUMBER OF MARKS, 200. PASS NUMBER, 100.

I. GENERAL CHEMISTRY.

*Wednesday, April 17th, from 10 a.m. till 1 p.m.*

1. What is the Composition of the Atmosphere ?
2. Describe the general characters of Salts of Ammonia, and a good method of determining Ammonia quantitatively.
3. Mention the most important Compounds of Nitrogen and Oxygen, and describe their principal properties.
4. Give an outline of the Manufacture of Oil of Vitriol.
5. How do you distinguish Lime from Magnesia ?
6. What is the chemical relation between Starch, Gum, Glucose, Cane-Sugar, and Alcohol ?
7. Mention some of the means of arresting the incipient decomposition of Organic matters, and the best plans of hastening the putrefaction of animal matters.
8. Describe some of the principal constituents of Blood.
9. What are the chemical changes which urine undergoes in becoming putrid? Point out the differences in the urine of herbivorous and carnivorous animals.

II. AGRICULTURAL CHEMISTRY.

*Wednesday, April 17th, from 2 p.m. till 5 p.m.*

1. Mention some of the causes of sterility of soils, and the means of removing them.
2. Under what circumstances is Lime advantageous to land? How and at what time of the year should it be applied ?
3. State the various methods of determining the quantity of Phosphoric acid in a soil; which method yields the most accurate results ?
4. Explain the chemical changes, if any, that occur in the following solutions in the act of percolating soils of various descriptions.
  1. Nitrate of Soda.
  2. Nitrate of Potash.
  3. Sulphate of Ammonia.
  4. Phosphate of Ammonia.
  5. Chloride of Sodium.
  6. Chloride of Potassium.

5. What is the amount of Nitrogen in

- 100 lbs. of Nitrate of Soda.
- „ Nitrate of Potash.
- „ Sulphate of Ammonia.
- „ Chloride of Ammonia.

6. How do you best prevent the loss of fertilizing matters in making farm-yard manure? Mention in general terms the differences in the composition of fresh and rotten dung.

7. What is the composition of Peruvian Guano? How can you ascertain whether it is genuine or adulterated? How should it be applied to the land, and for what crops is it most suitable?

8. What is the composition and feeding value of malt-dust, rice-meal, bran, and brewer's grains?

9. Write a short paper on the principles which ought to guide the farmer in the selection of food for calves, store cattle, fattening beasts and milk-cows.

---

### EXAMINATION IN MECHANICS AND NATURAL PHILOSOPHY.

MAXIMUM NUMBER OF MARKS 200. PASS NUMBER 100.

*Thursday, April 18th, from 10 a.m. till 1 p.m.*

1. If two given forces act on a point, what is the method of finding the single force that would balance them?

Suppose the forces to be of 5 and 7 units respectively, and to act in directions at right angles to each other; show by a figure how the force acts which exactly balances them, and determine in any way its magnitude and direction.

2. In the case of a single fixed pulley the power is said to equal the weight; on what suppositions would this be strictly true?

Given, two pulleys in separate blocks: show by diagrams various ways of combining them, and mention the advantage obtained in each way.

3. A rectangular block of stone 2 feet square and 4 feet high weighs a ton: if it stands upright on a horizontal plane what is the smallest force necessary to overthrow it? If it were lying lengthwise on the horizontal plane, what would be the smallest force needed to bring it into an upright position? Why is it that in raising the block, its tendency to slide does not ordinarily show itself till it has been raised through a considerable angle?

4. A horse is known to do 10 million units of work in a day; it is found that by means of certain machinery he raises 70 loads of 1000 lbs.

each from a depth of 100 feet in the course of a working day; what portion of his working power has been expended on the friction of the machinery?

5. A body weighing twelve tons is moved along a smooth horizontal plane by a constant horizontal force, and is found at the end of 4 seconds to be moving at the rate of 5 feet per second: what is the amount of that force? If the plane had been rough and this force had just not moved the body, what would have been the co-efficient of friction between the plane and the body ( $g = 32.2$ )?

6. A ball weighing 1 cwt. is fastened to the end of a rod; the rod is horizontal and at the other end is attached a vertical spindle; the distance from the spindle to the centre of the ball is 8 feet. If the ball makes 80 revolutions per minute, what force does it exert on the spindle? In what units do you estimate the result?

7. What is meant by the "dead points" of a crank? Explain how the fly-wheel tends to equalize the motion of machinery.

8. Explain the method of finding the specific gravity of a liquid by ascertaining the loss of weight of a given substance when immersed in the liquid. Give a numerical example.

9. Describe briefly the effects produced by the application of heat to a liquid. What is meant by a saturated vapour?

---

## EXAMINATION IN MENSURATION AND LAND SURVEYING.

MAXIMUM NUMBER OF MARKS, 100. PASS NUMBER, 50.

*Thursday, April 18th, from 2 p.m. till 5 p.m.*

1. A common hipped roof is 30 feet wide and 50 feet long, the height of the ridge above the eaves is 10 feet; how many squares of slate are there in the roof?

2. Draw on your paper a figure with four unequal sides; construct a triangle equal in area to this figure, and then construct a square equal in area to the triangle.

3. Give a rule for finding the solid contents of a piece of rough or unsquared timber, and give a numerical example. Mention briefly the reason of the rule you give.

4. It is said that 50 cubic feet of dry oak weigh 25 cwts. In this rule what is the assumed value of the specific gravity of dry oak?

5. A well is 5 feet in diameter and 50 feet deep; how many cubic feet of earth have been dug out in making it?

6. There are two poles, one on each side of a pond; both are acces-

sible and the surrounding ground is level; give a method of determining the distance between the poles by tape and pickets.

7. Let A, B, C, D be four stations inclosing a piece of wooded ground; the angle at A is a right angle; plot the accompanying notes to scale, and determine the area of the wood.

8. The three sides of a triangle are 7500 feet, 5000 feet, and 7500 feet respectively; find the angles and area of the triangle.

9. Two stations A and B are three miles apart; A bears  $57^\circ$  W. of N. from B; there is a third station, P, such that A bears  $22^\circ$  W. of N. from P, and B bears  $38^\circ$  E. of N. from P. Show how to lay down P on paper, and ascertain by scale the distance from P to A and from P to B.

	D. A.
0	1,300
120	1,200
100	800
0	000
	L off D

	C. D.
0	1,100
100	800
120	300
0	000
	L off C

	B. C.
0	1,400
60	400
0	000
	L off B

	A. B.
0	1,200
50	800
100	120
0	000

Begin at A go South

**EXAMINATION IN BOOKKEEPING.**

MAXIMUM NUMBER OF MARKS, 200. PASS NUMBER, 100.

*Friday, April 19th, from 10 a.m. till 1 p.m.*

Journalise and post into a ledger, in proper technical language, the following series of facts and transactions; and from such ledger make out a Trial Balance, a Profit and Loss Account, and Balance Sheet.

Liabilities and Assets of Peter Barrett, Seed Merchant, December 31st, 1871.

LIABILITIES.	£	s.	d.
Amount due to P. James .. .. .	160	13	4
Do. J. Smith for 1 quarter's rent due			
Xmas .. .. .	125	0	0
Bills payable, due 4th January, 1872 .. .. .	185	9	3

ASSETS.		£	s.	d.
	Stock of seeds in hand .. .. .	1200	0	0
	Do. Carts, horses, &c. .. .. .	155	5	0
	Cash at Messrs. Glyn & Co.'s—			
	on current account .. .. .	234	9	8
	on deposit account .. .. .	500	0	0
	Do. Petty in house .. .. .	3	8	4
	Lease of business premises .. .. .	500	0	0
1872.				
Jan.	1. Paid P. James .. .. .	60	13	4
"	" Accepted P. James' draft due 4th April ..	100	0	0
"	3. Sold seeds for cash .. .. .	280	5	6
"	4. Paid bill due this day .. .. .	185	9	3
"	5. Transferred from deposit to current account	200	0	0
"	" Interest to date also transferred .. .. .	2	6	8
"	6. Drawn cheque for petty cash .. .. .	10	0	0
"	9. Bought for cash 3 tons of hay for use in stables .. .. .	13	10	0
"	10. Sold seeds to D. Prout .. .. .	348	10	0
"	11. Bought seeds of James Muir .. .. .	286	0	0
"	15. Paid J. Smith rent due Xmas .. .. .	125	0	0
"	20. Received invoice of grain from D. Jones on consignment .. .. . £436 0 0			
"	" Accepted D. Jones' draft due 24th March ..	400	0	0
"	25. Paid expenses on above consignment out of Petty Cash .. .. .	7	8	6
"	26. Sold D. Jones' grain to P. Jameson for ..	492	10	4
"	27. Received Jameson's acceptance 30th April ..	492	10	4
"	" Paid D. Jones' balance of con- signment .. .. . £92 10 4			
	Less 1 per cent. commission			
	£4 18 4			
"	" expenses 7 8 6 12 6 10	80	3	6
"	29. Paid Insurance on Stock, &c. .. .. .	12	0	0
"	31. Paid clerk one month's salary .. .. .	10	0	0
"	" Allowed for wear and tear of carts, &c. ..	4	10	0
"	" Interest on Capital for one month .. .. .	8	16	10
"	" Stock of seeds in hand .. .. .	930	10	0

EXAMINATION IN GEOLOGY.

MAXIMUM NUMBER OF MARKS, 100. PASS NUMBER, 50.

*Friday, April 19th, from 2 p.m. till 5 p.m.*

1. State some of the advantages of a knowledge of Geology as applied to Agriculture.
2. By what different agencies have rocks been formed? Give examples of some of the principal kinds of rock.

3. Explain the various geological conditions under which springs occur.

4. Give the characters and composition of the so-called "Coprolites"; state the geological formations in which they are found, and the uses to which they are applied.

5. Define the terms "Permeable" and "Impermeable" strata; give examples derived from the Cretaceous system of rocks.

6. What is understood by "Brash" soils, and upon what formations do they occur?

7. Name the sub-divisions of the Oolitic system of rocks. Give their mineral characters, and state the chief economical substances obtained from them.

8. Define the terms Septaria, Loam, Shale, Marl, Pan, Oolite Conglomerate.

9. What would you expect to be the physical and agricultural features of districts situated on the following formations:—Chalk, Upper Green Sand, Red Marl, Old Red Sandstone, Lower Oolites?

10. Name some fossils which are characteristic of each of three great divisions of Stratified rocks.

11. Contrast agriculturally and geologically the chalk districts of the Wolds of Lincolnshire and Yorkshire with those of the North and South Downs, and explain the differences.

12. Name the rocks and fossils on the table.

---

## EXAMINATION IN BOTANY.

[It is expected that Eight Questions at least be answered.]

MAXIMUM NUMBER OF MARKS, 100. PASS NUMBER, 50.

*Saturday, April 20th, from 10 a.m. till 1 p.m.*

1. Describe the difference in the growth of the stem and roots.

2. What organs are employed by plants in which to store up food? Give examples.

3. Explain the changes that take place in the stored food before it can be appropriated by the plant.

4. What is Phyllotaxy?

5. What is the function of the leaf in the active life of the plant?

6. What are the distinctions between a dicotyledonous and a monocotyledonous plant in relation to (a) the seed, (b) the root, (c) the stem, and (d) the foliage?

7. Give the principal groups into which dicotyledonous plants are arranged, with their distinguishing characters, and an example of each.

8. What are gymnosperms? Give examples.

9. What is mycelium, and what order of plants does it characterise?
  10. Distinguish between mycelium and prothallus.
  11. What are the scientific names and natural orders of Rye-grass, Dock, Rape, Cow-grass, Dodder, and Barley?
  12. Describe in a systematic method the plants marked A, B, and C.
- 

EXAMINATION IN ANATOMY AND ANIMAL  
PHYSIOLOGY.

MAXIMUM NUMBER OF MARKS, 100. PASS NUMBER, 50.

*Saturday, April 20th, from 2 p.m. till 5 p.m.*

1. Name the bones of the hind leg of the horse in the order of their arrangement from above, downwards, and state the popular names which are given to each.
  2. State which joints of the hind limb possess a hinge movement only, and describe the nature of the other articulations.
  3. Describe in general terms the structure of the mammary gland of the cow, and name the vessels which convey the blood for its nourishment and for the secretion of milk. State also the means by which the blood is returned from the gland to the heart.
  4. State in what essential particulars arterial blood differs from venous.
-



## MEMORANDA.

**ADDRESS OF LETTERS.**—The Society's office being situated in the postal district designated by the letter **W**, members in their correspondence with the Secretary, are requested to subjoin that letter to the usual address.

**GENERAL MEETING** in London, in December, 1872.

**GENERAL MEETING** in London, May 22nd, 1873, at 12 o'clock.

**MEETING** at Hull, July, 1873.

**MONTHLY COUNCIL** (for transaction of business), at 12 o'clock on the first Wednesday in every month, excepting January, September, and October: open only to Members of Council and Governors of the Society.

**ADJOURNMENTS.**—The Council adjourn over Passion and Easter weeks, when those weeks do not include the first Wednesday of the month; from the first Wednesday in August to the first Wednesday in November; and from the first Wednesday in December to the first Wednesday in February.

**OFFICE HOURS.**—10 to 4. On Saturdays, from the Council Meeting in August until the Council Meeting in April, 10 to 2.

**DISEASES of Cattle, Sheep, and Pigs.**—Members have the privilege of applying to the Veterinary Committee of the Society; and of sending animals to the Royal Veterinary College, on the same terms as if they were subscribers to the College.—(A statement of these privileges will be found in the Appendix.)

**CHEMICAL ANALYSIS.**—The privileges of Chemical Analysis enjoyed by Members of the Society will be found stated in the Appendix to the present volume.

**BOTANICAL PRIVILEGES.**—The Botanical Privileges enjoyed by Members of the Society will be found stated in the Appendix to the present volume.

**SUBSCRIPTIONS.**—1. Annual.—The subscription of a Governor is £5, and that of a Member £1, due in advance on the 1st of January of each year, and becoming in arrear if unpaid by the 1st of June. 2. For Life.—Governors may compound for their subscription for future years by paying at once the sum of £50, and Members by paying £10. Members who have paid their annual subscription for 20 years or upwards, and whose subscriptions are not in arrear, may compound for future annual subscriptions, that of the current year inclusive, by a single payment of £5.

**PAYMENTS.**—Subscriptions may be paid to the Secretary, in the most direct and satisfactory manner, either at the office of the Society, No. 12, Hanover Square, London, W., or by means of post-office orders, to be obtained at any of the principal post-offices throughout the kingdom, and made payable to him at the Vere Street Office, London, W.; but any cheque on a banker's or any other house of business in London will be equally available, if made payable on demand. In obtaining post-office orders care should be taken to give the postmaster the correct initials and surname of the Secretary of the Society (H. M. Jenkins), otherwise the payment will be refused to him at the post-office on which such order has been obtained; and when remitting the money-orders it should be stated by whom, and on whose account, they are sent. Cheques should be made payable as drafts on demand (not as bills only payable after sight or a certain number of days after date), and should be drawn on a London (not on a local country) banker. When payment is made to the London and Westminster Bank, St. James's Square Branch, as the bankers of the Society, it will be desirable that the Secretary should be advised by letter of such payment, in order that the entry in the banker's book may be at once identified, and the amount posted to the credit of the proper party. No coin can be remitted by post, unless the letter be registered.

**NEW MEMBERS.**—Every candidate for admission into the Society must be proposed by a Member; the proposer to specify in writing the full name, usual place of residence, and post-town, of the candidate, either at a Council meeting, or by letter addressed to the Secretary. Forms of Proposal may be obtained on application to the Secretary.

---

\* \* \* Members may obtain on application to the Secretary copies of an Abstract of the Charter and Bye-laws, of a Statement of the General Objects, &c., of the Society, of Chemical, Botanical, and Veterinary Privileges, and of other printed papers connected with special departments of the Society's business.

## Members' Veterinary Privileges.

### I.—SERIOUS OR EXTENSIVE DISEASES.

No. 1. Any Member of the Society who may desire professional attendance and special advice in cases of serious or extensive disease among his cattle, sheep, or pigs, will, on application to the Secretary, obtain the services of the Society's Veterinary Inspector, to visit the place where the disease prevails.

No. 2. The remuneration of the Inspector will be 2*l.* 2*s.* each day as a professional fee, and 1*l.* 1*s.* each day for personal expenses; and he will also be allowed to charge the cost of travelling to and from the locality where his services may have been required. The fees and expenses will be a charge against the applicant; but this charge may be reduced or remitted altogether at the discretion of the Council, on such course being recommended to them by the Veterinary Committee.

No. 3. The Inspector, on his return from visiting the diseased stock, will report to the Committee, in writing, the results of his observations and proceedings, which Report will be laid before the Council.

No. 4. When contingencies arise to prevent a personal discharge of the duties confided to the Inspector, he may, subject to the approval of the Committee, name some competent professional person to act in his stead, who shall receive the same rates of remuneration.

### II.—ORDINARY OR OTHER CASES OF DISEASE.

Members may obtain the attendance of the Veterinary Inspector on any case of disease by paying the cost of his visit, which will be at the following rates, viz., 2*l.* 2*s.* per diem, and travelling expenses.

### III.—CONSULTATIONS WITHOUT VISIT.

Personal consultation with the Veterinary Inspector .. ..	5 <i>s.</i>
Consultation by letter .. .. .	5 <i>s.</i>
Consultation necessitating the writing of three or more letters.	10 <i>s.</i>
Post-mortem examination, and report thereon .. .. .	10 <i>s.</i>

A return of the number of applications during each half-year being required from the Veterinary Inspector.

### IV.—ADMISSION OF DISEASED ANIMALS TO THE VETERINARY COLLEGE INVESTIGATIONS; LECTURES, AND REPORTS.

No. 1. All Members of the Society have the privilege of sending cattle, sheep, and pigs to the Infirmary of the Royal Veterinary College, on the same terms as if they were Members of the College; viz., by paying for the keep and treatment of cattle 10*s.* 6*d.* per week each animal, and for sheep and pigs "a small proportionate charge to be fixed by the Principal according to circumstances."

No. 2. The College has also undertaken to investigate such particular classes of disease, or special subjects connected with the application of the Veterinary art to cattle, sheep, and pigs, as may be named by the Council.

No. 3. In addition to the lectures now given by the Professor of Cattle Pathology to the pupils in the Royal Veterinary College, on special occasions the College undertake that one of the Professors shall also deliver such lectures before the Members of the Society, at their house in Hanover Square, as the Council shall desire.

No. 4. The Royal Veterinary College will authorise the Principal to furnish to the Council, quarterly, a detailed Report of the cases of cattle, sheep, and pigs treated in the Infirmary; and also Special Reports from time to time on any matter of unusual interest, which may come under the notice of the College.

By order of the Council,

H. M. JENKINS, *Secretary.*

## Members' Privileges of Chemical Analysis.

THE Council have fixed the following rates of Charge for Analyses to be made by the Consulting Chemist for the *bonâ-fide* use of Members of the Society; who (to avoid all unnecessary correspondence) are particularly requested, when applying to him, to mention the kind of analysis they require, and to quote its number in the subjoined schedule. The charge for analysis, together with the carriage of the specimens, must be paid to him by members at the time of their application.

No. 1.—An opinion of the genuineness of Peruvian guano, bone-dust, or oil-cake (each sample) .. .. .	5s.
„ 2.—An analysis of guano; showing the proportion of moisture, organic matter, sand, phosphate of lime, alkaline salts, and ammonia .. .. .	10s.
„ 3.—An estimate of the value (relatively to the average of samples in the market) of sulphate and muriate of ammonia, and of the nitrates of potash and soda .. .. .	10s.
„ 4.—An analysis of superphosphate of lime for soluble phosphates only .. .. .	10s.
„ 5.—An analysis of superphosphate of lime, showing the proportions of moisture, organic matter, sand, soluble and insoluble phosphates, sulphate of lime, and ammonia ..	£1.
„ 6.—An analysis (sufficient for the determination of its agricultural value) of any ordinary artificial manure .. .. .	£1.
„ 7.—Limestone:—the proportion of lime, 7s. 6d.; the proportion of magnesia, 10s.; the proportion of lime and magnesia .. .. .	15s.
„ 8.—Limestone or marls, including carbonate, phosphate, and sulphate of lime, and magnesia with sand and clay ..	£1.
„ 9.—Partial analysis of a soil, including determinations of clay, sand, organic matter, and carbonate of lime .. .. .	£1.
„ 10.—Complete analysis of a soil .. .. .	£3.
„ 11.—An analysis of oil-cake, or other substance used for feeding purposes; showing the proportion of moisture, oil, mineral matter, albuminous matter, and woody fibre; as well as of starch, gum, and sugar, in the aggregate ..	£1.
„ 12.—Analyses of any vegetable product .. .. .	£1.
„ 13.—Analyses of animal products, refuse substances used for manure, &c. .. .. . from 10s. to 30s.	
„ 14.—Determination of the “hardness” of a sample of water before and after boiling .. .. .	10s.
„ 15.—Analysis of water of land drainage, and of water used for irrigation .. .. .	£2.
„ 16.—Determination of nitric acid in a sample of water .. .. .	£1.

N.B.—*The above Scale of Charges is not applicable to the case of persons commercially engaged in the Manufacture or Sale of any Substance sent for Analysis.*

The Address of the Consulting Chemist of the Society is, Dr. AUGUSTUS VOELCKER, F.R.S., 11, Salisbury Square, London, E.C., to which he requests that all letters and parcels (postage and carriage paid) should be directed.

By order of the Council,

H. M. JENKINS, *Secretary.*

## INSTRUCTIONS FOR SELECTING AND SENDING SAMPLES FOR ANALYSIS.

**ARTIFICIAL MANURES.**—Take a large handful of the manure from three or four bags, mix the whole on a large sheet of paper, breaking down with the hand any lumps present, and fold up in tinfoil, or in oil silk, about 3 ozs. of the well-mixed sample, and send it to 11, SALISBURY SQUARE, FLEET STREET, E.C., by post: or place the mixed manure in a small wooden or tin box, and send it by post. If the manure be very wet and lumpy, a larger boxful, weighing from 10 to 12 ozs., should be sent either by post or railway.

Samples not exceeding 4 ounces in weight may be sent by post, by attaching two penny postage stamps to the parcel.

Samples not exceeding 8 ounces, for three postage stamps.

Samples not exceeding 12 ounces, for four postage stamps.

The parcels should be addressed: DR. AUGUSTUS VOELCKER, 11, SALISBURY SQUARE, FLEET STREET, LONDON, E.C., and the address of the sender or the number or mark of the article be stated on parcels.

The samples may be sent in covers, or in boxes, bags of linen or other materials. No parcel sent by post must exceed 12 ozs. in weight, 1 foot 6 inches in length, 9 inches in width, and 6 inches in depth.

**SOILS.**—Have a wooden box made 6 inches long and wide, and from 9 to 12 inches deep, according to the depth of soil and subsoil of the field. Mark out in the field a space of about 12 inches square; dig round in a slanting direction a trench, so as to leave undisturbed a block of soil with its subsoil from 9 to 12 inches deep; trim this block or plan of the field to make it fit into the wooden box, invert the open box over it, press down firmly, then pass a spade under the box and lift it up, gently turn over the box, nail on the lid and send it by goods or parcel train to the laboratory. The soil will then be received in the exact position in which it is found in the field.

In the case of very light, sandy, and porous soils, the wooden box may be at once inverted over the soil and forced down by pressure, and then dug out.

**WATERS.**—Two gallons of water are required for analysis. The water, if possible, should be sent in glass-stoppered Winchester half-gallon bottles, which are readily obtained in any chemist and druggist's shop. If Winchester bottles cannot be procured, the water may be sent in perfectly clean new stoneware spirit-jars surrounded by wickerwork. For the determination of the degree of hardness before and after boiling, only one quart wine-bottle full of water is required.

**LIMESTONES, MARLS, IRONSTONES, AND OTHER MINERALS.**—Whole pieces, weighing from 3 to 4 ozs., should be sent enclosed in small linen bags, or wrapped in paper. Postage *2d.*, if under 4 ounces.

**OILCAKES.**—Take a sample from the middle of the cake. To this end break a whole cake into two. Then break off a piece from the end where the two halves were joined together, and wrap it in paper, leaving the ends open, and send parcel by post. The piece should weigh from 10 to 12 ozs. Postage, *4d.* If sent by railway, one quarter or half a cake should be forwarded.

**FEEDING MEALS.**—About 3 ozs. will be sufficient for analysis. Enclose the meal in a small linen bag. Send it by post.

On forwarding samples, separate letters should be sent to the laboratory, specifying the nature of the information required, and, if possible, the object in view.

H. M. JENKINS, *Secretary.*

## Members' Botanical Privileges.

The Council have provisionally fixed the following rates of Charge for the examination of Plants and Seeds for the *bonâ fide* use of Members of the Society, who are particularly requested, when applying to the Consulting Botanist, to mention the kind of examination they require, and to quote its number in the subjoined Schedule. The charge for examination must be paid to the Consulting Botanist at the time of application, and the carriage of all parcels must be prepaid.

No. 1.—A general opinion as to the genuineness and age of a sample of clover-seed (each sample) .. .. .	5s.
,, 2.—A detailed examination of a sample of dirty or impure clover-seed, with a report on its admixture with seeds of dodder or other weeds (each sample) .. .. .	10s.
,, 3.—A test examination of turnip or other cruciferous seed, with a report on its germinating power, or its adulteration with 000 seed (each sample) .. .. .	10s.
,, 4.—A test examination of any other kind of seed, or corn, with a report on its germinating power (each sample) .. .. .	10s.
,, 5.—Determination of the species of any indigenous British plant (not parasitic), with a report on its habits (each species) .. .. .	5s.
,, 6.—Determination of the species of any epiphyte or vegetable parasite, on any farm-crop grown by the Member, with a report on its habits, and suggestions (where possible) as to its extermination or prevention (each species) .. .. .	10s.
,, 7.—Report on any other form of plant-disease not caused by insects .. .. .	10s.
,, 8.—Determination of the species of a collection of natural grasses indigenous to any district on one kind of soil (each collection) .. .. .	10s.

### INSTRUCTIONS FOR SELECTING AND SENDING SAMPLES.

In sending seed or corn for examination the utmost care must be taken to secure a fair and honest sample. If anything supposed to be injurious or useless exists in the corn or seed, selected samples should also be sent.

In collecting specimens of plants, the whole plant should be taken up, and the earth shaken from the roots. If possible the plants must be in flower or fruit. They should be packed in a light box, or in a firm paper parcel.

Specimens of diseased plants or of parasites should be forwarded as fresh as possible. Place them in a bottle, or pack them in tin-foil or oil-silk.

All specimens should be accompanied with a letter specifying the nature of the information required, and stating any local circumstances (soil, situation, &c.) which, in the opinion of the sender, would be likely to throw light on the inquiry.

N.B.—*The above Scale of Charges is not applicable in the case of Seedsmen requiring the services of the Consulting Botanist.*

Parcels or letters (Carriage or Postage prepaid) to be addressed to Mr. W. CARRUTHERS, F.R.S., 25, Wellington Street, Islington, London.

H. M. JENKINS, *Secretary.*

LONDON:

Printed by WILLIAM CLOWES and SONS, Stamford Street,  
and Charing Cross. . .

---

GOVERNORS AND MEMBERS

OF THE

ROYAL AGRICULTURAL SOCIETY  
OF ENGLAND.

1872.

---

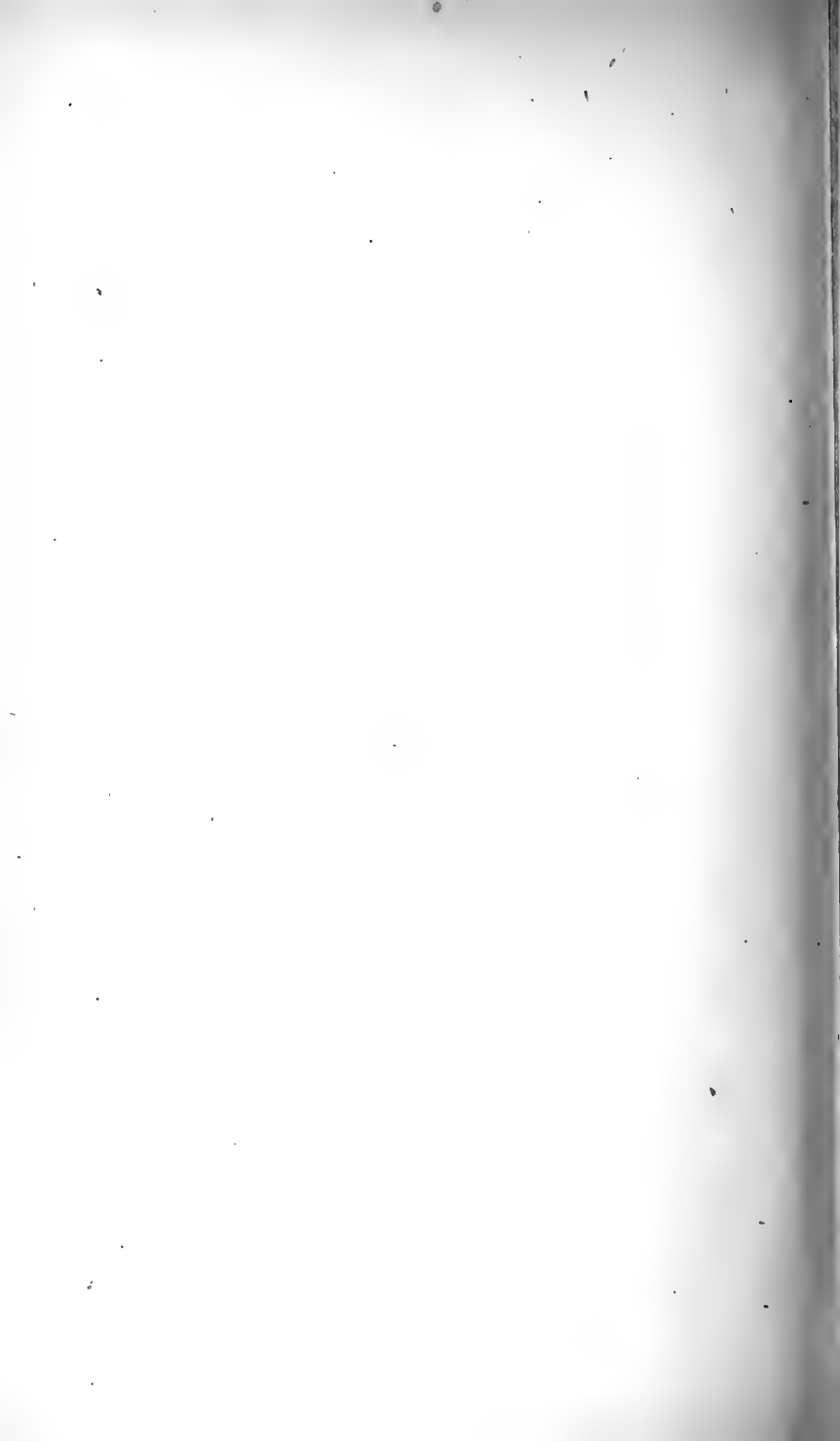



# ROYAL AGRICULTURAL SOCIETY OF ENGLAND.

## Patroness,

HER MAJESTY THE QUEEN.

## List of Governors.

† Life Governor's mark.

- Allcroft, John D. . . . Harlington, Middlesex  
† Aldam, William . . . Frickley Hall, Doncaster, Yorkshire  
Allison, Arthur . . . Tilgate Forest Lodge, Crawley, Sussex  
Allison, Charles F. . . . Tilgate Forest Lodge, Crawley, Sussex  
† Arkwright, J. Hungerford . . . Hampton Court, Leominster, Herefordshire
- Barclay, Hedworth David . . . Eastwick Park, Leatherhead, Surrey  
† Barker, John Raymond . . . Fairford Park, Fairford, Gloucestershire  
Barrow, William Hodgson, M.P. . . . Southwell, Nottinghamshire  
† Bath, Marquis of . . . Longleat, Warminster, Wilts.  
Bective, Lord . . . Underley Hall, Kirby Lonsdale  
Bedford, Duke of . . . Woburn Abbey, Bedfordshire  
† Belper, Lord . . . Kingston Hall, Derby  
Blount, William . . . Orchhill, Gerrard's Cross, Bucks.  
† Bowes, John . . . Streatham Castle, Staindrop, Durham  
Bridport, Major-General Viscount . . . Cricket St. Thomas, Chard, Somersetshire  
† Brown, James . . . Rossington, Bawtry, Notts.  
Buccleuch, Duke of, K.G. . . . Montague House, Whitehall, S.W.  
† Buller, Sir Edward Mauningham, Bart., M.P. . . . Dilhorne Castle, Cheadle, Staffs.  
Buxton, Sir Robert Jacob, Bart. . . . Shadwell Court, Thetford, Norfolk
- Cabbell, Benjamin Bond . . . Cromer Hall, Norfolk  
† Cambridge, H.R.H. Duke of, K.G. . . . Gloucester House, Piccadilly, W.  
Camoys, Lord . . . Stonor Park, Henley-on-Thames, Oxfordshire  
Carnarvon, Earl of . . . High Clere Castle, Newbury, Berks.  
† Cathcart, Earl, Thornton-le-Street, Thirsk, Yorkshire  
Challoner, Colonel C. B. . . . Portuall Park, Staines, Middlesex  
Chaplin, Henry, M.P. . . . Blankney Hall, Lincoln  
† Chesham, Lord . . . Latimer, Chesham, Bucks.  
Chichester, Earl of . . . Stanmer Park, Lewes, Sussex  
† Childers, John Walbanke . . . Cantley Hall, Doncaster, Yorkshire  
† Cholmeley, Sir Montague J., Bart., M.P. . . . Easton Hall, Colsterworth, Linc.  
† Clive, Rev. Archer . . . Whitfield, Hereford

- †Coleman, Edward J...Stoke Park, Slough, Bucks.  
 Cotes, John...Woodcote, Newport, Salop.  
 Courtauld, Samuel...Gosfield Hall, Halstead, Essex  
 †Craven, Earl of...Coombe Abbey, Coventry, Warwickshire  
 Curteis, Major Edward Barrett...Leesam House, Rye, Sussex
- Darnley, Earl of...Cobham Hall, Gravesend, Kent  
 †Dartmouth, Earl of...Patshall Hall, Wolverhampton, Staffordshire  
 †Davies, David Reynolds...High Legh Hall, Knutsford, Cheshire  
 Devonshire, Duke of, K.G....Holker Hall, Milnthorpe, Westmoreland  
 Dickinson, Francis Henry...King's Weston, Somerton, Somersetshire  
 †Duleep Singh, his Highness the Maharajah...Elveden Hall, Thetford, Norfolk  
 †Dunmore, Earl of...Dunmore, N. B.  
 †Dysart, Earl of...Buckminster Hall, Colsterworth, Lincolnshire
- Egmont, Earl of...Cowdray Park, Petworth, Sussex  
 †Ellesmere, Earl of...Worsley Hall, Manchester  
 Essex, Earl of...Cassiobury Park, Watford, Hertfordshire  
 †Etwall, Ralph...Andover, Hampshire  
 Evans, Thomas William...Allestree Hall, Derby  
 †Eversley, Viscount...Heckfield Place, Winchfield, Hants.  
 †Eyre, Charles...Welford, Newbury, Berkshire
- Farquharson, John James...Langton, Blandford, Dorset  
 †Fellowes, Edward, M.P....Ramsey Abbey, Huntingdon  
 FitzWalter, Lord...Godneston Park, Wingham, Kent  
 †Fortescue, Earl...Castle Hill, South Molton, Devon.  
 †Freeland, H. W....Chichester, Sussex  
 †Fuller, Francis...3, Whitehall Gardens, S.W.
- Gainsborough, Earl of...Exton Hall, Oakham, Rutlandshire  
 Gibbs, B. Thomas Brandreth...47, Half-moon Street, Piccadilly, W.  
 †Grey, Earl...Howick House, Alnwick, Northumberland
- Hale, Robert Blagden...Alderley Park, Wootton, Gloucestershire  
 †Harcourt, George Simon...35, St. George's Square, S.W.  
 Hartley, W. H. H....Lye Grove, Cross Hands, Sodbury, Gloucestershire  
 Hertford, Marquis of...Ragley Park, Alcester  
 †Heywood, Sir T. Percival, Bart....Doveleys, Ashbourne, Derbyshire  
 †Hill, Viscount...Hawkstone Park, Shrewsbury, Salop.  
 †Hoghton, Sir Henry de, Bart....Travellers' Club, S.W.  
 †Holford, R. Stayner, M.P....Weston Birt House, Tetbury, Gloucestershire  
 Holland, Edward...Dumbleton Hall, Evesham, Worcestershire  
 †Howe, Earl...Gopsall, Atherstone, Warwickshire  
 †Hulse, Col. Sir Edward, Bart....Breamore House, Fordingbridge, Hampshire  
 †Hunt, Zachary D. . .Aylesbury, Bucks.
- Johnstone, Sir Harcourt, Bart., M.P....Hackness Hall, Scarborough, Yorkshire
- Kerrison, Sir Edward Clarence, Bart....Brome Hall, Scole, Norfolk  
 Kesteven, Lord...Caswick, Stamford, Lincolnshire  
 †Knight, Frederick Winn, M.P....Wolverley House, Kidderminster, Worcestershire

- †Le Couteur, Colonel... Belle Vue, Jersey  
Lekh, William John, M.P.... Lyme Park, Disley, Stockport, Lancashire  
†Leicester, Earl of... Holkham Hall, Norfolk  
†Leigh, Lord... Stoneleigh Abbey, Warwickshire  
†Lonsdale, Earl of... Lowther Castle, Penrith, Cumberland  
Lovell, Earl of... East Horsley Towers, Woking Station, Surrey  
Loyd, Lewis... Monks Orchard, Bromley, Kent
- †Macdonald, Sir A. K., Bart.... Woolmer Lodge, Liphook  
Marlborough, Duke of, K.G.... Blenheim Park, Oxon.  
†Marshall, William... Rattendale Hall, Penrith, Cumberland  
†Miles, Sir William, Bart.... Leigh Court, Bristol, Somersetshire  
Montefiore, Joseph Meyer... Worth Park, Crawley, Sussex  
†Morrison, Alfred... Fonthill House, Hindon, Wilts.  
Murray, Charles Robert Scott... Danesfield, Marlow, Buckinghamshire
- Nisbet-Hamilton, Right Hon. R.A.... Bloxholme Hall, Sleaford, Lincolnshire  
†Northwick, Lord... 7, Park Street, Grosvenor Square, W.
- Ormathwaite, Lord... Warfield Park, Bracknell, Berkshire  
Ossington, Viscount... Ossington, Newark-on-Trent
- Palmer, Robert... Holme Park, Reading, Berkshire  
Patten, Col. John Wilson, M.P.... Bank Hall, Warrington, Lancashire  
Penrhyn, Lord... Penrhyn Castle, Bangor, Carnarvonshire  
†Perkins, Algernon... Hanworth Park, Hounslow, W.  
†Popham, Francis Leyborne... Puckaster, Isle of Wight  
†Portman, Lord... Bryanston House, Blandford, Dorsetshire  
†Powis, Earl of... Powis Castle, Welshpool, Montgomeryshire
- †Richmond, Duke of, K. G... Goodwood, Chichester, Sussex  
Ridley, Sir Matthew White, Bart... Blagdon, Cramlington, Northumberland  
Rigg, Jonathan... 4, Chester Place, Hyde Park Square, W.  
Ripon, Marquis of, K.G., Studley Royal, Ripon, Yorkshire  
Robartes, Lord... Lanhydrock House, Bodmin, Cornwall  
†Rutland, Duke of, K.G... Belvoir Castle, Grantham, Lincolnshire
- Saint Germans, Earl of... Port Eliot, Devonport, Devonshire  
†Sanford, Edward Ayshford... Nynehead Court, Wellington, Somersetshire  
†Sefton, Earl of... Croxteth, Liverpool  
†Shadwell, Lucas... Fairlight, Hastings, Sussex  
†Sondes, Lord... Elmham Hall, Thetford, Norfolk  
Sotheron-Estcourt, Rt. Hon. Thos. H. S... Estcourt, Tetbury, Gloucestershire  
†Southampton, Lord... Whittlebury Lodge, Tōwcester, Northamptonshire  
Stafford, Lord... Cossey Hall, Norwich, Norfolk  
†Stradbroke, Earl of... Henham Park, Wangford, Suffolk  
†Sutherland, Duke of, K.G... Stafford House, St. James's, S.W.  
†Sutton, John Manners... Kelham, Newark, Notts.
- †Tanqueray, John Samuel...  
†Thompson, H. S... Kirby Hall, York  
†Torrington, Viscount... Yokes Court, Mereworth, Kent

VI *Governors of the Royal Agricultural Society of England.*

Towneley, Col. Charles...Towneley, Burnley, Lancashire

†Tredegar, Lord...Tredegar Park, Newport, Monmouthshire

†Vernon, Lord...Sudbury Hall, Derby

Wales, H.R.H. Prince of, K.G., &c...Marlborough House, S.W.

†Warner, Edward...Higham Hall, Woodford, Essex

†Warwick, Earl of...Warwick Castle, Warwick

†Whitbread, William Henry...Southhill House, Bedford

†Wilson, Lieut. Col. Fuller Maitland...Stowlangtoft Hall, Bury St. Edmund's, Suffolk

Wynn, Sir Watkin Williams, Bart., M.P...Wynnstay, Rhuabon, Denbighshire

Zetland, Earl of...Aske Hall, Richmond, Yorkshire

## List of Members.

† Life Member's mark.

## A.

Abbot, Chas. H. . . . . Bower, Long Ashton, Bristol  
 † Abbott, Stephen, jun. . . . . Castleacre, Swaffham  
 Abbott, Wm. . . . . Hill Farm, Gt. Wigborough, Colchester  
 Abbotts, R. W. . . . . Burton-on-Trent  
 Abercorn, Duke of, K.G. . . . . 58, Green Street, W.  
 † Abergavenny, Earl of. . . . . Eridge Castle, Tunb. Wells  
 Abraham, Thomas . . . . . Dunster, Taunton  
 † Abrey, Thomas Shaw Hellier . . . . . Witham, Essex  
 † Ackers, B. St. J. . . . . Prinknash Park, Painswick, Stroud  
 Acland, Sir T. Dyke, Bt. M.P. . . . . Sprydoncote, Exeter  
 Acock Arthur. . . . . Cold Aston, Northleach  
 Acton, William . . . . . Fern Acres, Slough  
 † Acworth, N. B. . . . . The Hook, Northaw, Middlesex  
 † Adams, G. T. . . . . Hawkhurst, Kent  
 Adams, James. . . . . The Fallows, Oxtou, Southwell  
 † Adderley, Rt. Hon. C. B., M.P. . . . . Hams Hall, Minworth  
 Addington, Rev. H. . . . . Henlow Grange, Biggleswade  
 Addison, John. . . . . 6, Delahay Street, Westminster  
 Addison, Joseph. . . . . Mapledurwell, Basingstoke  
 Addison, J. . . . . Brookfield, Grettou, Uppingham  
 Adkins, George C. . . . . The Lightwoods, Birmingham  
 Adkins, Henry. . . . . The Firs, Edgbaston, Birmingham  
 Agate, Alfred. . . . . Horsham  
 Agnew, C. Swain. . . . . Springfield, Eccles, Manchester  
 Agnew, T. Jun. . . . . Hopeleigh, Eccles, Manchester  
 † Ahrens, E. . . . . New Schlagsdorf, Mecklenbg., Schwerin  
 Aitkin, James. . . . . Peterborough  
 Akers, Henry. . . . . Black Bourton, Faringdon  
 † Akroyd, Edward, M.P. . . . . Bank Field, Halifax  
 Alcock-Beck, William. . . . . Hawkshead, Windermere  
 Alderman, Rev. F. C. . . . . Kintbury, Hungerford  
 † Alderson, John. . . . .  
 Aldous, James Arthur. . . . . Lingwood, Norwich  
 † Aldridge, Major J. . . . . St. Leonard's Forest, Horsham  
 † Aldworth, W., jun. . . . . Frilford, Abingdon  
 † Alexander, Edward. . . . . Leominster  
 Alexander, J. C. . . . . Herne Hill, Faversham  
 † Alexander, R. C. B. . . . . Downs House, Staplehurst  
 Alexander, W. L. . . . . Shatton Lodge, Cockermouth  
 † Alington, G. M. . . . . Swinhope House, Grimsby  
 Alison, John. . . . . 90, Lancaster Gate, W.  
 Allcock, Charles. . . . . Bulwell, Nottingham  
 Allcock, Thomas. . . . . Radcliffe-on-Trent, Nottingham  
 † Allen, B. Haigh. . . . . Clifford Priory, Hereford  
 Allen, George. . . . . The Manor Farm, Old Windsor  
 Allen, George. . . . . Knightley Hall, Eccleshall  
 Allen, Henry. . . . . Oakfield, Hay, Herefordshire  
 † Allen, John. . . . . Knighton, Leicester

Allen, Joseph, jun. . . . . 19, Seymour Street, Leicester  
 Allen, Major Ralph S., M.P. . . . . Shockerwick, Bathford  
 Allen, Rev. Dr. . . . . Shouldham Hall, Downham Market  
 Allen, Stephen H. . . . . Eastover, Andover  
 Allen, Thomas. . . . . Thurmaston, Leicester  
 Allenby, George. . . . . Hallington, Louth, Lincolnshire  
 Allender, G. M. . . . . 6, Dawson Place, Bayswater, W.  
 Allender, H. J. . . . . 6, Belmont Rd., Anfield, Liverpool  
 Allerton, Alex. R. . . . . Colemans, Prittlewell, Essex  
 † Allfrey, H. W. . . . . Hemingford Ho., Stratford-on-Avon  
 † Allfrey, Robert. . . . . Wakefield Park, Reading  
 Allison, James John . . . . . Sunderland  
 Allison, R. A. . . . . Scaleby Hall, Carlisle  
 Allnut, Albert A. . . . . Hunsdon Lodge, Ware  
 Allnut, T. Alexander. . . . . Watlington Farm, Tetsworth  
 Allix, W. Townley. . . . . Campsea Ash, Wickham Mkt.  
 Allsopp, Henry. . . . . Hindlip Hall, Worcester  
 † Ambler, Henry. . . . . Watkinson Hall, Halifax  
 Amcotts, Col., M.P. . . . . Hackthorn Hall, Lincoln  
 Ames, Lionel. . . . . The Hyde, St. Albans  
 † Amhurst, W. A. T. . . . . Didlington Park, Brandon  
 Amos, James, jun. . . . . Broomfield, Herne Bay  
 Amos, James C. . . . . West Barnet Lodge, Herts.  
 † Amos, Chas. E. . . . . 5, Cedars Road, Clapham Common  
 † Ananoff, Alexander. . . . . Koutais, Russia  
 † Ananoff, Ivan. . . . . Moscow  
 † Anderson, Alexander. . . . .  
 Anderson, Rev. C. G. . . . . Countesthorpe, Leicester  
 † Anderson, R. . . . . Grey Street, Newcastle-upon-Tyne  
 Anderson, Robert A. . . . . Cirencester  
 † Anderson, William. . . . . Lesney House, Erith, Kent  
 Andrews, Henry. . . . . Wylve, Heytesbury  
 Andrews, Onslow. . . . . Brabourne, Ashford  
 Angas, George. . . . . Beeford Grange, Lowthorpe, Hull  
 Angerstein, W. T. N. . . . . Ashby Lodge, Rugby  
 Angrave, Thomas C. . . . . East Leake, Loughborough  
 Angus, George. . . . . Benwell Grange, Newcastle-on-Tyne  
 Angus, John. . . . . Whitefield, Morpeth  
 † Anson, Sir John, Bart. . . . . Avisford, Arundel  
 Anstey, Samuel. . . . . Menabilly Farm, Par Station  
 † Anstruther, J. H. L. . . . . Hintlesham Hall, Ipswich  
 Anthony, John. . . . . Yealmpton, Plympton  
 † Aplin, Henry. . . . . Coombe St. Nicholas, Chard, Somerset  
 † Appach, Reginald. . . . . Maytham Hall, Rolvenden, Kent  
 † Applewhaite, Edward. . . . . Pickenham Hall, Swailham  
 Apps, John, jun. . . . . Goudhurst, Staplehurst  
 Arabin, W. St. Julien. . . . . Englefield Green, Egham  
 † Aranzo, Captain F. J. da Silva. . . . . Rio de Janeiro  
 † Arbutnot, John A. . . . . Cowarth, Chertsey, Surrey

Arbathnot, W. U... Bridgen Place, Kent  
 Archer, James... Combermere Abbey, Whitchurch  
 Ardron, John... Queniborough, Leicester  
 †Argles, F. Atkinson... Eversley, Milnthorpe  
 Arkcoll, Thomas... The Meads, Eastbourne  
 Arkell, H... Butlers Ct., Boddington, Cheltenham  
 †Arkell, Thomas... Pen Hill Farm, Swindon, Wilts.  
 Arkell, Thomas... Boddington, Cheltenham  
 Arkle, T... Highlows, Morpeth, Northumberland  
 Arkwright, A. W... Broughton Astley Ho., Lutterworth  
 Armitage, Arthur... Moraston, Ross, Herefordshire  
 Armstrong, George... Thornton Heath, Surrey  
 Armstrong, H., M. D... Peckham Ho., Peckham, S. E.  
 Armstrong, J. A... Bay's Leap, Wylam, Northumberland  
 Armstrong, J. Knight... Wharton Hall, Winsford  
 Armstrong, T. J... Hawthorn Ter., Newcastle-on-Tyne  
 Armstrong, Wm. Jones... Fairlie, Greenock  
 Arnold, George, jun... Dolton, North Devon.  
 Arnold, James... 35, West Smithfield, E. C.  
 Arnold, Matthew... Westmeon, Petersfield  
 Arnold, Ralph... Shackerstone, Atherstone  
 Arnold, Rev. Richard A... Ellough, Beccles  
 Arnold, William... Lichfield Street, Tamworth  
 Arnott, T. Reid... Bramshill, Harlesden Green, N. W.  
 Arthur, Col. Charles... Misterton Hall, Lutterworth  
 Ashburton, Lord... Bath House, Piccadilly, W.  
 Ashcroft, Thomas... Walford, Ecclehall, Staffs.  
 Ashdown, S. H... Uppington, Wellington, Salop.  
 Ashurst, John H... Waterstock, Oxford  
 Ashlin, John... Firsky, Spilsby  
 Ashmore, John... Norton, Evesham  
 †Ashton, H... Murray Place, Nova Scotia, Liverpool  
 †Ashton, T. Henry... Temple Laugherne, Worcester  
 Ashton, T. M... Deeping St. Nicholas, Spalding  
 Ashwin, Manley C... Stratford-on-Avon  
 Ashworth, Alfred... Egerton Hall, Bolton  
 Ashworth, Charles E... Fairfield, Manchester  
 †Askew, Sir H., Br... Pallinsburn Ho., Coldstream  
 †Askew, Watson... Pallinsburn, Coldstream  
 Asten, William... Oddingley, Droitwich  
 Asterley, W. L... The Pentief, Llanymynech, Oswest.  
 †Astley, F. L... E. E. ... Melton Constable, Thetford  
 †Aston, S... Bushwood Lodge, Henley-in-Arden  
 †Atchison, Wm... Bowling Iron Company, Bradford  
 †Atherton, T... Chapel House, Speke, Liverpool  
 †Athorpe, J. C... Dinnington Hall, Rotherham  
 †Atkinson, James... Winderwath, Penrith  
 †Atkinson, J. H. H... Angerton, Morpeth  
 †Atkinson, W... Gt. Rapers, Bures St. Mary's  
 Atkinson, William... Ashton Hayes, Chester  
 Attenborough, Richard... Whilby Grove, Reading  
 Attwater, J. Gay... Britford, Salisbury  
 Austin, Harry Colley... Allscot, Wellington, Salop.  
 Aveland, Lord... Normanton Park, Oakham  
 Aveling, Thomas... Rochester  
 Averill, Charles, Jun... Pyrehill, Stone, Staffs.  
 Averill, E... Wood Gate, King's Bromley, Lichfield  
 Averill, George Hanson... Wood End, Lichfield  
 Avery, Thomas Charles... Gloucester  
 †Avery, Wm. Howard... Tixall Heath, Stafford  
 Awbery, F. D... St. Lawrence Wootton, Basingstoke  
 Awcock, Henry... Oxen Heath, Tunbridge, Kent  
 †Aylmer, H... West Dereham, Stoke Ferry, Norfolk

†Aylmer, J. B... Fincham Hall, Downham, Norfolk  
 †Aylmer, R. B... Westacre Abbey, Swaffham  
 †Aytoun, R. S., M. P... Inchdairnie, Kirkcaldy, N. B.

## B.

†Babington, Prof. Charles Cardale... Cambridge  
 Bacchus, W. E... Horley, Banbury  
 †Back, J. A... Old Hall, Hethersett, Wymondham  
 Backhouse, R. Onions... Westwood, Bridgnorth  
 Bacon, Rev. H... Baxterley Rectory, Atherstone  
 Bacon, James, Pluckley, Ashford, Kent  
 Bacon, Samuel, jun... Ratcliffe Culey, Atherstone  
 †Backhouse, Edmund, M. P... Polam Hill, Darlington  
 Badoock, Benjamin... Headington Hill, Oxford  
 Badoock, P... 4, Aldridge Rd. Villas, Westbourne Pk  
 Badoock, Rev. T... Fleckney, Market Harboro'  
 Badham, George... Wingmoor, Cheltenham  
 Badham, G. D... Bulmer Tye, Sudbury  
 Bagnall, George... Draycot, Cheadle, Staffordshire  
 Bagot, Rev. R. Wolfe... Fontstown, Athy, Kildare  
 †Bagot, Lord... Blithfield, Rugeley, Staffordshire  
 Bailey, Edward... Leicester  
 †Bailey, Henry... Cirencester  
 †Bailey, Henry James... Rosedale Farm, Tenbury  
 †Bailey, James... Burnham, Bridgwater  
 †Bailey, James... St. Stephens, St. Albans  
 Bailey, J. B... 4, Coley Hill, Reading  
 †Bailey, Sir J. R., Bt., M. P... Glanusk, Crickhowell  
 †Bailey, Wm... Hazling, Belford, Northumberland  
 †Baillie, Evan... Filleigh, Chudley, Devon.  
 †Baillie, Hamilton... Ash Hall, Cowbridge  
 Baillie, Lieut. Col. H. S... Househill, Nairn, N. B.  
 Baillie, Wm. H... 43, Norfolk Sq., Hyde Park, W.  
 Baily, John... 113, Mount St., Berkeley Square, W.  
 Baily, John... Python Hill, Mansfield, Notts.  
 Baily, Rev. H. G... The Vicarage, Swindon  
 Baily, T. F... 11, Queen Street, May Fair, W.  
 Bainbridge, E. M... Dissington, Newcastle-on-Tyne  
 Bainbridge, Robt. S... Woodhorn Grange, Morpeth  
 †Baird, Alexander... Robston Hall, Milford Haven  
 Baker, C. N... Half-moon Passage, Gracechurch-st., E. C.  
 †Baker, Sir E. Baker, Bart... Ranston Ho., Blandford  
 Baker, G. W... 48, Cambridge Ter., Cliphm. Rd., S. W.  
 Baker, H. Orde Lloyd... Hardwicke Court, Gloucester  
 †Baker, Hugh Massey... Kidnall, Malpas, Cheshire  
 Baker, John... Hockley, Rayleigh, Essex  
 †Baker, John...  
 Baker, J. W... Little Rolbright, Chipping Norton  
 †Baker, Lake J... Hargrave, Kimbolton  
 Baker, Robert... Gamston, East Retford  
 Baker, Rev. R. Lowbridge... Ramsden, Enstone, Oxon.  
 †Baker, T. Barwick L... Hardwicke Court, Gloucester  
 Baker, Thomas... Barton, Cambridge  
 Baker, Thomas... Blackstone, Bewdley  
 Baker, William... Moor Barns, Atherstone  
 Baker, William... Combe Farm, Woodstock, Oxford  
 †Baker, Wm. H... Brooklands, Worthing  
 †Baldwin, John... Luddington, Stratford-on-Avon  
 Baldwin, Thomas... Glasnevin, Dublin  
 Baldwin, T... Earl's Wood, Hockley Heath, Bmghm.  
 Baldwin, Wm. H... Normanton Hall, Normanton

Baldwin, W. J. A. . . . Dalton-in-Furness, Lancaster  
 Balfour, D. . . . Balfour Castle, Kirkwall, N.B.  
 Ball, George. . . . North Kilworth, Rugby  
 Ball, James. . . . Peterstone Mills, Cardiff  
 Ball, William. . . . Rothwell, Kettering  
 Ballard, Philip. . . . Leighton Court, Bromyard  
 Balleny, C. D. . . . Red Barns, Newcastle-on-Tyne  
 Balmer, Thomas. . . . Fochabers, N.B.  
 Balston, Richard J. . . . Boxley Abbey, Maidstone  
 Balston, Thomas. . . . Chart Sutton, Staplehurst  
 Balstone, Henry K. . . . Hale Carr, Altrincham  
 Bamlett, A. C. . . . Thirsk  
 Bankes, J. Scott. . . . Soughton Hall, Northop, Flints.  
 Banks, John Jackson. . . . Kendal  
 Bannerman, Alexander. . . . Lytham, Lancashire  
 Bannerman, Henry. . . . Hunton Court, Maidstone  
 Banstock, Thomas. . . . Merridale Ho., Wolverhampton  
 Banyard, T., jun. . . . Poplar Hall, Horningsea, Cambs.  
 Barber, George. . . . Titlington Mount, Alnwick  
 Barber, Richard. . . . Harlescott, Shrewsbury  
 Barbour, George. . . . Kingslee, Farndon, Chester  
 Barbour, R. . . . Bolesworth Castle, Chester  
 Barclay, F. . . . Horsted Place, Horsted, Uckfield  
 Barclay, John. . . . Falmouth  
 Barclay, G. R. . . . Oxford and Cambridge Club  
 Barclay, W. Leatham. . . . Knott's Green, Leyton, E.  
 Barclay, William. . . . Peterborough  
 Barling, John. . . . Oakwood, Chichester  
 Barker, Edward. . . . Pickburn, Doncaster  
 Barker, G. I. Raymond. . . . 17, Royal Crescent, Bath  
 Barker, H. B. Raymond. . . . University Cl., Suffolk St.  
 Barker, J. H. . . . Rowsley, Bakewell, Derbyshire  
 Barker, Thomas. . . . Bramall Grange, Stockport  
 Barker, Walter R. H. . . . Wantage  
 Barklow, F. . . . The Shrubbery, Hasketon, Woodbridge  
 Barknall, Charles. . . . Norwich  
 Barknaldston, Nathaniel C. . . . The Ryes, Sudbury  
 Barneby, William. . . . Clater Park, Bromyard  
 Barneby-Lutley, J. H. . . . Brockhampton, Worcester  
 Barnes, C. A. . . . Charlingwood, Rickmansworth  
 Barnes, John. . . . Shenstone, Lichfield  
 Barnes, T. . . . The Quinta, Chirk, N. Wales  
 Barnes, Thomas. . . . Westland, Moynalty, co. Meath  
 Barnes, Thomas. . . . Bunker's Hill, Carlisle  
 Barnes, Wilson. . . . Teigh, Oakham  
 Barnett, Charles. . . . Stratton Pk., Biggleswade, Beds.  
 Barnett, Henry, M.P. . . . Glympton Park, Woodstock  
 Barnett, R. . . . Meopham Court, Gravesend  
 Barnett, T. J. . . . 13, North Street, Wolverhampton  
 Barnett, William E. . . . Newcastle-on-Tyne  
 Barratt, C. Underwood. . . . Eccleshall, Staffordshire  
 Barrett, John B. . . . Milton House, Steventon, Berks.  
 Barbovy, Miss Elizabeth. . . . Dishforth, Thirsk  
 Barrow, John James. . . . Normanton Hall, Southwell  
 Barrow, Wm. . . . Bilbrooke House, Wolverhampton  
 Barrs, Mrs. Maria. . . . Odstone Hall, Atherstone  
 Barstow, Charles D. . . . Garrow Hill, York  
 Bartholomew, W. . . . Waddington Heath, Lincoln  
 Barthropp, N. G. . . . Hacheston, Wickham Market  
 Barton, Charles. . . . Holbrook House, Wincanton  
 Barton, Charles. . . . Fifield, Lechlade  
 Barton, Gerard. . . . Fundenhall, Wymondham  
 Barton J. . . . Westleigh Lodge, Leigh, Manchester

† Barton, Rev. H. N. . . . St. Ervan Rectory, Padstow  
 † Barton, J. Hope. . . . Stapleton Park, Pontefract  
 Barton, James Pipe. . . . Bangley, Tamworth  
 Barton, Richard. . . . Caldly Manor, Birkenhead  
 Barton, Thomas. . . . The Crescent, Carlisle  
 Bartram, William. . . . Harrogate, Yorkshire  
 † Barwell, Thomas. . . . Leicester  
 Baskerville, H. . . . Crawshay Park, Reading  
 Baskett, Nathaniel. . . . Wetheringsett, Stonham  
 Bass, Michael T., M.P. . . . Burton-on-Trent  
 Bass, W. . . . Duckenfield Lodge, Ashton-under-Lyme  
 † Bassett, Richard. . . . Bonvilstone, Cardiff  
 Batchelor, T. B. . . . Maindee, Newport, Mon.  
 Bate, Edward. . . . Kelsterton, Flintshire, N. Wales  
 Bate, John William. . . . Astol, Shifnal, Salop.  
 Bate, John. . . . 10, St. Mary's, Manchester  
 Bate, Richard Stokes. . . . Badger, Shifnal  
 Bate, Samuel. . . . Springfields, Newcastle-under-Lyme  
 † Bateman, Henry. . . . Asthall, Witney, Oxon.  
 Bateman, J. . . . Croxton Hamner, Whitchurch, Salop.  
 † Bateman, Lord. . . . Shobden Court, Shobden  
 † Bates, George. . . . Blaxhall Hall, Wickham Market  
 Bates, Thomas, jun. . . . Eaton Green, Luton, Beds.  
 † Bathur, Thomas. . . . Maesbury Hall Mill, Oswestry  
 Bathurst, Earl. . . . 38, Half-moon Street, W.  
 Bathurst, Lt.-Col. . . . Qarendon Park, Salisbury  
 † Batson, Thos. . . . Bath  
 Batt, William Henry. . . . West Drayton, Uxbridge  
 † Battock, F. . . . Hemingford Abbots, St. Ives, Hunts.  
 † Batten, John. . . . Yeovil  
 Battle, John R. . . . Potter Hanworth, Lincoln  
 Baumbach, Henry. . . . South Elmham Hall, Harleston  
 Baumgardt, Edmund C. . . .  
 † Baxendale, J. . . . Woodside, Whetstone, N.  
 Baxendale, Richard B. . . . Whetstone, Herts, N.  
 Baxter, Benjamin. . . . Elslack Hall, Skipton  
 Baxter, H. J. . . . Cheadle, Manchester  
 Baxter, Robert. . . . Doncaster  
 Baxter, Thomas. . . . Acton Grange, Warrington  
 † Bayden, Thomas. . . . Hythe, Kent  
 † Bayden, Thomas, jun. . . . Hythe, Kent  
 Bayes, Charles. . . . Kettering  
 Bayley, Capt. D. . . . Friarstown Ho., Tallaght, Dublin  
 Bayley, John. . . . Tilstock, Whitchurch, Salop.  
 Bayley, Thomas. . . . Lenton, Nottingham  
 † Bayley, Rev. W. R. . . . Cassington Vicarage, Oxford  
 Bayly, John. . . . Plymouth  
 Bayning, Lady. . . . Honingham Hall, Norwich  
 Bayzand, Joseph. . . . Kingley, Alcester, Redditch  
 Bazley, Thomas S. . . . Hatherop, Fairfield, Gloucester  
 Beach, J. . . . Standeford Cottage, Wolverhampton  
 Beach, J. Allen. . . . The Park, Redmarley, Newent  
 † Beach, Sir M. E. H. Bt., M.P. . . . Williamstrip, Fairford  
 Beach, Mrs. Sarah. . . . The Hattons, Brewood, Staffs.  
 Beachel, John. . . . Rawcliffe, Selby, Yorkshire  
 Beadel, Wm. James. . . . Chelmsford  
 Beadon, Rev. F. . . . North Stoneham Rectory, Hants.  
 Beale, E. J. . . . 237, High Holborn, W.C.  
 Beale, Joseph. . . . Wolsey Grange, Hincley  
 † Beale, William. . . . Larkins Farm, Chiddingstone  
 Beales, William. . . . Barton Hall, Mildenhall  
 Bealey, J. Edward. . . . Bloxwich, Walsall, Staffs.  
 † Bean, Alfred W. . . . Dansom Park, Welling, S.E.

- †Bearcroft, E.... Mere Hall, Droitwich  
 †Beard, Frederic... Horton, Canterbury  
 Beards, Thomas... Stowe Park, Buckingham  
 Bearn, William... Finedon Hill, Wellingborough  
 Beart, Charles... Stow Bardolph, Downham Market  
 †Beart, Robert... Godmanchester, Huntingdonshire  
 Beasey, J. Noble... Pittsford Hall, Northampton  
 Beasley, John... Brampton, Northampton  
 †Beattie, James... Newbie House, Annan, N.B.  
 Beauchamp, Chas. D... .93, Lansdowne Road, W.  
 Beauchamp, Sir T. W. B., Bt... Langley Hl., Norwich  
 Beaumont, E. B... Woodhall, Barnsley, Yorkshire  
 †Beaumont, Geo., jun... Bridgeford Hill, Notts.  
 †Beaumont, J. A... Park House, Wimbledon, S.W.  
 Beaumont, Joseph... Ducklington, Witney, Oxford  
 †Beaumont, W. B., M.P. Bywell Hall, Newc.-on-Tyne  
 Beaven, C... Ivy Ho. Farm, Shipton Moine, Tetbury  
 Beaven, James... West Leaze Farm, Swindon  
 Beck, Charles W... Upton Priory, Macclesfield  
 Beck, Edmund... Sandringham, King's Lynn  
 Beck, Francis Henry... Albrighton, Shifnal  
 Beck, Peter... Shrewsbury  
 Becker, J. L... Foxdenton, Chadderton, Manchester  
 Beckett, Richard... Hartford, Northwich, Cheshire  
 Beckett, Samuel... Eccleston, Chester  
 Beckett, Richard... Watton Abbey, Driffield  
 †Beckwith, Rev. H. Eaton Constantine, Wellington,  
 †Beckwith, Thos. Percival... [Salop.  
 Beecroft, C... Lowdham Lodge Farm, Nottingham  
 Bev, Jas. Henry... .29, St. George's St., Canterbury  
 Beeston, T... Goldstone Manor, Market Drayton  
 Beeston, William... Kidderminster  
 Beaver, Rev. William Holt... Pencraig Court, Ross  
 Beevor, Henry... Blyth, Worksop  
 †Begg, David, M.D... Canons Park, Edgware, N.W.  
 Belcher, Charles... The Crescent, Bedford  
 †Beldam, Valentine... Royston, Hertfordshire  
 Bell, Ancill... Manor House, N. Kyme, Steepleport  
 Bell, H... Hempshaw Brook Brewery, Stockport  
 Bell, Capt. Henry... Chalfont Lodge, Cheltenham  
 Bell, John... Breaks Hall, Appleby, Westmoreland  
 Bell, J. Williams... Gillingham, Bath  
 Bell, Matthew... Bourne Park, Canterbury  
 Bell, Robert... Newcastle-on-Tyne  
 †Bell, Robert... Mallgate, Brampton  
 Bell, Thomas... Plaistow, E.  
 Bell, William... Cramlington, Northumberland  
 Bellow, J. Froude... Stockleigh Court, Crediton  
 Beman, Thomas... Weston-Subedge, Broadway  
 †Bence, Capt... Kentwell Hall, Long Melford  
 Bence, Henry A... Thorington Hall, Saxmundham  
 Benington, T...  
 †Bennell, Joseph... Hitchin, Herts.  
 Bennet, Philip... Roughton Hall, Bury St. Edmund's  
 Bennett, Alfred William... Wharton, Ross  
 †Bennett, B. E... Marston Trussell Hall, Rugby  
 Bennett, E. Gasking... Plymouth  
 Bennett, Rev. Henry Leigh... Thorpe, Egham  
 Bennett, James... Ingestone, Ross  
 Bennett, John... Little Rissington, Burford, Oxon.  
 Bennett, John... The Banks, Mountfield, Hurst Green  
 Bennett, John Ewins... Bosworth Grange, Rugby  
 Bennett, Joseph B. H... Tutbury, Burton-on-Trent  
 Bennett, Stephen White... Wareham, Dorset  
 Bennett, Thos. Oatley... Bruton, Somersetshire  
 Bennett, W... Yate, Chipping Sodbury  
 †Bennion, Owen... Cresswell, Stafford  
 Benson, C... .98, Bull Street, Birmingham  
 †Benson, George... Lutwyche Hall, Wenlock, Salop.  
 Benson, John... Countess Weir, Exeter  
 †Benson, William... Allerwash House, Hexham  
 Bentall, E. H., M.P... Heybridge, Maldon, Essex  
 Bentley, Robert John... .7, Hall Cross, Doncaster  
 Bentley, T... Davenham, Northwich, Cheshire  
 Benyon, Rev. E. R... Culford, Bury St. Edmund's  
 †Benyon, R., M.P... Englefield House, Reading  
 Beridge, Rev. Basil... Algarkirk, Spalding  
 †Berkeley, Robert... Spetchley Park, Worcester  
 †Berners, John... Holbrook, Ipswich  
 †Berners, Lady... Keythorpe Hall, Leicester  
 †Berney, Sir Hanson, Bart... Sheepy, Atherstone  
 Berridge, Samuel... Croughton, Brackley  
 Berridge, Thos... Pimlico Farm, Tusmore, Bicester  
 †Berrington, A. D... Pant y Goitre, Newport, Mon.  
 Berry, Edward... Ashley, Market Harborough  
 Berry, William... High Street, Leicester  
 Besley, Henry... South Street, Exeter  
 Bessborough, Earl of... Pilltown, Ireland  
 †Best, Hon. and Rev. S... Abbotts Ann, Andover  
 Best, James, jun... Hill Top, Tenbury  
 Best, John B... Stanstead Abbots, Ware  
 †Best, J. V... .32, Guildford Rd., South Lambeth, S.W.  
 Best, Rev. Thomas... Red Rice House, Andover  
 Beswicke-Royds, C.R.N... Pyke House, Littleborough  
 Bethell, William... Rise, Beverley  
 †Bethune, Alexander... Blebo, Cupar, Fife, N.B.  
 †Bettinson, R... Cawthorpe, Bourne, Lincolnshire  
 Betts, E. Ludd... Holmwood, Bickley, Kent  
 Bevan, Beckford... Bury St. Edmund's  
 Bevan, G. Innes... Godmanchester, Huntingdon  
 Bevan, William R... Bury St. Edmund's  
 Beverley, Matthew B... Leeds  
 Bibby, J. J... Hardwicke Grange, Shrewsbury  
 Bickerton, S... Shotatton, Ruyton 11 Towns, Salop.  
 Bickford, Joseph... Oxley, Wolverhampton  
 Biddell, G. Arthur... Ipswich  
 †Biddell, Herman... Playford, Ipswich  
 †Biddell, Manfred... Playford, Ipswich  
 †Biddell, W... Lavenham Hall, Sudbury  
 Bidwell, Charles M... Ely  
 Bigg, T... Leicester House, Great Dover Street, S.E.  
 Bigge, Chas. Selby... Bourton Grange, Much Wenlock  
 Biggs, John... Cublington, Leighton Buzzard  
 Bill, John... Trent Vale, Stoke-on-Trent  
 Billington, John S... Netherset Key, Madeley, Staffs.  
 Bingham, Col. R. H... Bingham Melcombe, Dorchester  
 Binney, Charles H... North Cheam, Surrey  
 †Birch, George Francis... Clare Park, Farnham  
 Birch, James... Pearse Hay, Penkridge  
 Birch, T... Broomhill Farm, Belmont, Hereford  
 Birchall, Edward... Willaston, Northwich  
 †Birchall, T... Kibbleton Hall, Preston, Lancashire  
 †Bircham, William G... Dunton, Fakenham  
 †Bird, J... Yaxley, Stilton, Huntingdonshire  
 †Bird, Rev. J. Waller... Foulsham Rectory, Norfolk  
 †Birkbeck, Henry... Norwich



Birkbeck, Robert...20, Berkeley Square, W.  
 irket, C....Plungington Hall, Preston, Lancashire  
 irkett, Joseph...Foxton House, Penrith  
 irt, Jacob...23, Sussex Gardens, Hyde Park, W.  
 iscoe, T.P.B....Kingellie House, Newton, Inverness  
 ishop, James...Looe, Cornwall  
 ishop, John...3, The Walk, Market Place, Norwich  
 Bixio, Maurice, C. E., 26, Rue Jacob, Paris  
 Blackburne, J. Ireland...Hale, Warrington †  
 Blackburne, Jas. Taddy...The Camp Farm, Aldershot  
 Blackburne, Lt.-Col. I., jun...Hale Hall, Warrington  
 Blacker, M. M....Claremount, Claremorris, Mayo  
 Blackett, Sir E., Bart....Matfen, Newcastle-on-Tyne  
 Blackstock, John...Hayton Castle, Maryport  
 Blackstone, J. . . . 1, Gloucester Rd., Regent's Park  
 Blackwell, G., jun...Hazlecote, Kingscote, Wootton-  
 under-Edge  
 Blgrave, Edward...Oxford  
 Blair, John...  
 Blake, Alfred...Sutton, Stanton-Harcourt, Witney  
 Blake, Francis John...Norwich  
 Blake, William...Bridge, Ilminster  
 Blake, Wm. John...Danesbury, Welwyn  
 Bland, George...Coley Hall, Lincoln  
 Bland, Henry Wainwright...Barlow, Chesterfield  
 Bland, William...Hartlip, Sittingbourne  
 Blandford, Thomas...Corbridge, Northumberland  
 Blane, Col. Robt....The Oaks, Sunninghill, Staines  
 †Blanshard, Richard...53, Chancery Lane, W.C.  
 Blantern, George G....Haston, Hadnall, Shrewsbury  
 Blashill, Henry...36, New Market Street, Hereford  
 Blathwayte, Geo. W., jun...Dyrham, Chippenham  
 Blencowe, J. George...Bineham, Lewes  
 †Blencowe, Robert A....  
 Blencowe, Robert Willis...The Hooke, Lewes  
 Blenkinsop, John...Simonside Ho., South Shields  
 Blick, John...Hill Court, Droitwich  
 †Blisset, Rev. H....Letton Weobley, Hereford  
 Bloxfield, John...Warham, Wells, Norfolk  
 Bloxidge, John Smith...Mere Pits, Tamworth  
 †Blow, W. W. Temple Mount, Belvedere Pk., Kent  
 Blundell, Arthur...Chediston Hall, Halesworth  
 Blundell, J. . . . 3, Portland Street, Southampton  
 †Blundell, John H....Woodside, Luton  
 Blurton, Edward...Wolverhampton  
 Blurton, W. Mountfort...Field Hall, Uttoxeter  
 Blyth, D'Urban...Great Massingham, Rougham  
 †Blyth, James...24, Hyde Park Gardens, W.  
 †Blyth, James...Weasenham All Saints, Brandon  
 Blyth, Thomas W....Aldington, Evesham  
 †Board, John...Westerham, Sevenoaks  
 Boards, Edward...Edmonton, N.  
 Boards, William...Edmonton, N.  
 †Boby, Charles...Stutton, Ipswich  
 †Boby, Robert...Bury St. Edmund's  
 †Boddington, Henry. Monton Ho., Eccles, Lancashire  
 Body, John...The College, Wittersham, Peasmarsh  
 †Body, R. B....Hyde End, Shinfield, Reading  
 Boger, Deeble...Wolsdon, Devonport  
 †Boger, Hext...Lower Durnford St., Stonehouse, Dev.  
 †Boghurst, William P....Frating Abbey, Colchester  
 Bolam, C. G....Savernake Forest, Marlborough  
 Bolam, Harry G....Keverstone, Stalndrop, Durlham

†Bolam, Robt. G....Weetwood Hall, Wooler  
 Bolam, W. T...Jesmond Gardens, Newcastle-on-Tyne  
 Bolden, Samuel E...The Council House, Shrewsbury  
 Holdero, John...Rattlesden, Woolpit  
 †Bolitho, Edward...Trewiden, Penzance  
 Bolitho, R. F....Ponsandam, Penzance  
 †Bolitho, T. S....Pendleverne, Penzance  
 †Bolitho, William...Penzance  
 †Bolton, Jasper...Ballykisteen, Tipperary  
 Bolton, John A., M.D. Belgrave Gate Ho., Leicester  
 †Bolton, Lord...Bolton Hall, Bedale  
 Bomford, Benjamin...Pitchill, Evesham  
 Bomford, Heming James...Dunnington, Alcester  
 Bond, Abraham...Hunstile, Bridgewater  
 Bond, Barnabas...Alburgh, Harleston, Norfolk  
 Bond, Benjamin...Draycot, Cheadle, Staffordshire  
 Bond, Peter...Draycot, Cheadle, Staffordshire  
 Bone, Henry...Avon, Ringwood, Hants.  
 Bonehill, C. G....Bickford Grange, Penkridge  
 Bonham, Rev. J....Ballingtaggart, Ballistore, Ireland  
 Bonnal, John...Grantham  
 †Bonner, H. C....East Rudham, Rougham, Norfolk  
 Booker, Joseph...Wilbrighton Hall, Newport, Salop.  
 †Booth, James Godfrey...Hamburg  
 Boot, William...Chesterfield, Lichfield  
 Booth, E. W....Trent Pk. Farm, New Barnet, Herts.  
 Booth, John B....Killerby, Catterick, Yorkshire  
 Booth, John...Cotham, Newark, Nottinghamshire  
 Booth, John...Shenstone Hall, Lichfield  
 Booth, N., jun...North Delph, Downham  
 Booth, Thomas...Tamborne Park, Lichfield  
 Booth, Thomas C....Warlaby, Northallerton  
 †Borie, Victor...14, Rue de Lille, Paris  
 Borman, Luke...Barnoldby-le-Beck, Grimsby  
 †Borough, C. B....Chetwynd Pk., Newport, Salop.  
 Borthwick, John...Prospect, Carrickfergus  
 Borthwick, William...Monkway, Whitehaven  
 †Bortier, Monsieur...43, Rue Royale, Brussels  
 Bolton, John...Barton-le-Street, Malton  
 †Bosanquet, Horace S....Broxbourne Pk, Hoddesden  
 Bosanquet, Rev. R. W....Roch, Alnwick  
 Bosanquet, S. Courthouse...Tanhurst, Dorking  
 Bosley, John...Lower Leyde, Hereford  
 Bostock, Edwin...The Haugh, Stafford  
 Bostock, Thomas...Hill Top, Burslem  
 Bosworth, J. Green...Greetham, Oakham  
 Botfield, Rev. W. B. Garnett...Decker Hill, Shifnal  
 †Botham, George...Wexham Court, Slough, Bucks.  
 Botly, Wm....Salisbury Villa, Upper Norwood, S.  
 Bott, Joseph Fennell...Morrell Rothing, Dunmow  
 Botterill, John...Eppleworth, Cottingham, Hull  
 Botting, William...Westmeston Pl., Hurstperpoint  
 Boucher, A. E....Wolverley, Kidderminster  
 Boucher, Charles...Caenby Hall, Market Rasen  
 Boucherett, Henry Robert...Hoarcross, Rugeley  
 †Bouck, John T....Manchester  
 Boulbee, J....Noyadd Ho., Aberayron, South Wales  
 Boulter, Thomas...Shenstone House, Kidderminster  
 Boulton, John...Bowling Green Farm, Shifnal  
 Boulton, R. C....Lower Balingham, Ross  
 Boulton, W. Baker...The Lizard, Shifnal  
 †Bourn, James...Studley, Redditch  
 Bourne, John...Hildenstone, Stone, Staffordshire

- Bourne, John... Bugsell Farm, Hurst Green  
 Bourne, S... Goldsmith House, Whitchurch, Salop.  
 Bourne, William... Atherstone  
 Bowen, Wm., jun...  
 Bowen, Edward H... Kingslow, Bridgnorth, Salop.  
 Bowen, Humphrey C... Chesterton, Bridgnorth, Salop.  
 Bowen, James B... Llwyngwair, Haverfordwest  
 Bowen, John, jun... Dunvall House, Bridgnorth.  
 Bowen, James... Troedyraur, Newcastle Emelyn  
 Bowen, Thomas, Wootton, Bridgnorth, Salop.  
 Bowers, Henry R... Abbot's Lodge, Chester  
 Bowler, Wm. Anthony... 4, Whitehall Place, S.W.  
 Bowling, Roger... Forton Lodge, Garstang  
 Bowly, Edward... Siddington House, Cirencester  
 Bowly, William... Cirencester  
 Bowman, J... High House, Sandwith, Cumberland  
 †Bowman, J. B... Sandicroft Farm, Hawerden  
 Bowser, R... Bishop Auckland, Durham  
 Bowstead, Jas. Cooper... Hackthorpe Hall, Penrith  
 †Bowstead, Thomas... Eden Hall, Penrith  
 †Bowyer, Capt. H. A... Steeple-Aston, Woodstock  
 Boxall, W. B... Strathfieldsaye, Winchfield  
 Boyd, E. Fenwick... Moor House, Durham  
 Boydell, Harry S... Sulham, Reading  
 Boyer, W... Sywell House, Northampton  
 Braby, James... Maybanks, Rudgwick, Horsham  
 Bracebridge, C. H... Atherstone Hall, Atherstone  
 Bradburn, Wilton... Hilton, Wolverhampton  
 Bradburne, J. Hanbury... Pipe Place, Lichfield  
 Bradbury, G. E. H... Longroyde, Rastrick, Yorks.  
 Bradbury, Wm... Bradley Green Colliery, Congleton  
 Braddock, Henry... Bury St. Edmund's  
 Bradford, Earl of... 43, Belgrave Square, S.W.  
 Bradford, Thomas... 63, Fleet Street, E.C.  
 †Bradshaw, John... Knowle, Cranleigh, Surrey  
 †Bradshaw, Capt., R.N... Tubney Lodge, Abingdon  
 Bradshaw, W... Slade Ho., Levenshulme, Manchester  
 Bradstock, Thomas S... Cobrey Park, Ross  
 Brady, Charles Alldis... Calne Green, Stockport  
 Brady, W. Hollinshed... Chestergate, Stockport  
 †Braikenridge, J. H... Chew Magna, Bristol  
 Bramley, Charles... Fiskerton Hall, Lincoln  
 Bramley-Moore, J... Gerrards Cross, Bucks.  
 Bramwell, F. J... 37, Gt. George St., Westminster  
 Brand, Rt. Hon. Henry, M.P... Glynde, Lewes  
 †Brander, R. B... Tanbridge House, Horsham  
 Branford, John W... March, Cambs.  
 Branson, William C... Little Weldon, Wansford  
 Branwhite, F... Chapel House, Long Melford, Suffolk  
 †Brassey, Henry A., M.P... 51, Queen's Gate, W.  
 Bravender, John... Cirencester  
 Bray, George... The Haven, Dilwyn, Leominster  
 †Braybrooke, Lord... Audley End, Saffron Walden  
 †Breach, J. G... Meaburn House, Upper Richmond  
 Brealey, John... Leek, Staffordshire [Road, Putney  
 Brebner, James... Norfolk Farm, Windsor Great Park  
 Breerton, Rev. J. Lloyd... Little Massingham, Rougham  
 Brett, John... Burton Joyce, Nottingham  
 Brett, John... Oxton Grange, Southwell  
 †Bretts, Chas...  
 Brewster, Jas...  
 Brewster, John... Stretton Mill, Penkridge  
 Brewster, Richard... Heathy Mills, Kidderminster  
 Brewster, S. N... The Limes, Rushmer, Ipswich  
 Brewster, W... Balderton Hall, Middle Shrewsbury  
 Brickwell, C. J... Overthorpe Lodge, Banbury  
 Bridge, Thomas... Wyntford Eagle, Dorchester  
 Bridge, Thomas... Buttsbury, Ingatstone  
 Bridgeman, John... Ascott Hall, Shrewsbury  
 Bridges, Harry... Stowmarket  
 Bridgland, Stephen... Springfield, Tooting  
 Bridgwood, George... Bedwall, Stafford  
 Brierley, C. W... Rhodes House, Middleton, Lanc.  
 Brierly, Harry, jun... Church Lawford, Rugby  
 Briggs, D. Grant... Calcethorpe Manor, Louth  
 †Briggs, Rawdon... Birstwith Hall, Ripley, Yorksh.  
 Briggs, Thos... The Homestead, Richmond, Surrey  
 Briggs, William... Hylton Castle, Sunderland  
 Briggs, William... Elford Park, Tamworth  
 Bright, John... Styche, Market Drayton, Salop.  
 †Bright, John... Bath Row House, Birmingham  
 †Briscoe, Sir Robert, Bt... Crofton Hall, Wigton  
 †Brise, Lieut.-Col. S.B.R... Spains Hall, Braintree  
 Britten, Thomas... Little Billing, Northampton  
 Broadbent, J. H... Sealand, Chester  
 †Broadhurst, John... Foston, Derby  
 Brodhurst, Lucas... Upton, Southwell  
 Brodie, John, jun. Braken Ho., Melsonby, Darlington  
 Brogden, Alexander, M.P... Ulverston  
 Bromet, William R... Cocksford, Tadcaster  
 Bromfield, H. Flint Hall, Wellesbourne, Warwick  
 Bromley, James... Forton, Garstang  
 Bromley, John... Derby  
 Bromley, John... Lancaster  
 †Bromley, J. R... Gesyns, Newmarket  
 Bromwich, Thomas... Woolston, Coventry  
 Brook, Arthur Sawyer... Bexhill, Hastings  
 Brook, Charles... Enderby Hall, Leicester  
 Brook, J... Park Farm, St. Helen's, Isle of Wight  
 Brooke, H... Wetheringsett, Stonham  
 Brooke, Rev. John... Houghton, Shifnal  
 Brooke, John W... Sibton Park, Yoxford, Suffolk  
 †Brooke, William... Northgate House, Huddersfield  
 †Brooke, Sir W. De Capell, Bart... Market-Harbo'  
 Brooks, J. M... 7, Charlotte Street, Manchester  
 Broomhall, T. T... Beech Cliff, Newcastle, Staffs.  
 †Broomhead, B. P... Broomhall Park, Sheffield  
 Brough, William S... Fowlchurch, Leek  
 Broughton, E. Delves... Wistaston Hall, Nantwich  
 †Broughton, P... Tunstall Hall, Market Drayton  
 †Brown, A. H. C... Kingston House, Tetsworth  
 Brown, B... Manor House, Shipbourne, Tunbridge  
 Brown, Benjamin... Thursford, Theford  
 Brown, Charles... Park Hall, Leigh, Cheadle, Staffs.  
 †Brown, Douglas... 15, Hertford Street, Mayfair  
 Brown, Edward... Worsley Grange, Manchester  
 Brown, George... Avebury, Calne  
 Brown, George... Roborough House, Barnstaple  
 Brown, Henry... Preston, Wellington, Salop.  
 Brown, Prof. Geo. T... 7A, New Cavendish St., W.  
 Brown, Henry... Ashby-de-la-Zouch  
 †Brown, Rev. H. H...  
 Brown, James... Liverpool Arms Hotel, Chester  
 Brown, John... Tring  
 Brown, John... Coldham Hall, Wisbeach  
 Brown, J. Washbourne... Ufcott, Swindon

Brown, Mathew...Scar Bank, Longtown  
 Brown, Michael L...Tillington, Stafford  
 Brown, Pereira...Glentworth Hall, Lincoln  
 Brown, Potto...Houghton, Huntingdon  
 Brown, Ralph...Whickham, Gateshead  
 Brown, Richard...Walton Bank, Stone, Staffs.  
 Brown, R...Ruyton Eleven Towns, Salop.  
 Brown, W. H....Brookfield House, Belbroughton  
 Brown, Robert...Wigginton House, Tamworth  
 Brown, Thomas...Buckham Hall, Uckfield  
 Brown, Thomas...Marham, Downham Market  
 Brown, Thomas...Horton, Devizes  
 Brown, Thos. James...The Moor, Hereford  
 Brown, William...Tring  
 Brown, William...Devizes  
 Brown, William...Wirswall, Whitchurch, Salop.  
 Brown, William...Holme-on-Spalding Moor, York  
 Brown, W. J....Hazlebury House, Chippenham  
 Browne, George...Troutbeck, Windermere  
 Browne, Lord J. T...Westport, co. Mayo  
 Browne, Philip M...Fornham, Bury St. Edmund's  
 Browne, Samuel...Brookton Hall, Shifnal  
 Browne, T. Beale...Salperton Park, Andoversford  
 Browne, T. B...Mellington Hall, Churchstoke  
 Browne, Rev. T. C...59, High Street, Oxford  
 Browning, James T...Oxford  
 Browning, S...Joint Counties Asylum, Abergavenny  
 Bruce, John...Tiddington, Stratford-on-Avon  
 Bruce, Maj. C. L. C., M.P...Dunphail, Forres, N.B.  
 Brunsdon, Benjamin...Ross  
 Brunskill, Stephen...Sand Area, Kendal  
 Bruzner, Rev. G. E., M.A...Thurlaxton, Hinckley  
 Bryan, Frederick Thos...Humberstone, Leicester  
 Bryan, John...Southleigh, Witney  
 Bubb, Anthony...Witcombe Court, Gloucester  
 Buck, Albert...Sansome Terrace, Worcester  
 Buckingham, Duke of...Wootton, Aylesbury  
 Buckland, G...Ontario, Toronto  
 Buckland, J. A...Frogs' Hole Farm, Biddenden  
 Buckland, Thomas, jun...Wraysbury, Staines  
 Buckley, Gen. E. P...New Hall, Salisbury  
 Buckley, Jas...Penyfaif Ho., Llanelly, Carmarthen.  
 Buckley, John N...Loughborough  
 Buckman, Prof...Bradford Abbas, Sherborne, Dorset  
 Budd, Francis...Hatch Warren, Basingstoke  
 Budd, J. Palmer...Ystalyfera, Swansea  
 Budd, Thos. W...13, Norfolk Cres., Hyde Pk., W.  
 Budd, William...Aston-le-Walls, Leamington  
 Buddicom, Wm. B...Penbedu Hall, Mold  
 Bugg, Walter...Milborne Wick, Sherborne  
 Buggins, W...Booth's Farm, New Oscott, Birming.  
 Bulford, James...Hordley Farm, Woodstock  
 Bulkeley, C. Rivers...Bodyllytn, Rhuabon  
 Bulkeley, Sir R. W., Bt., M.P...Baron Hill, Beaumaris  
 Bulkeley, T. F...Clewer Lodge, Windsor  
 Bull, J. H. W...Great Wolford, Shipston-on-Stour  
 Bullen, John T...Marshwood Manor, Crewkerne  
 Buller, Morton Edward...Dilhorn, Cheadle  
 Bullock, Ferdinand...Wantage, Berks.  
 Bullock, George...East Coker, Somerset  
 Bulmer, Jeffery, jun...Middleton, Darlington  
 Bult, James S...Dodhill Ho., Kingston, Taunton  
 Bulteel, John...Pamflete, Ivybridge

Bultift, H...Bedwellhay Grange, Ely  
 Bulwer, Walter Redford...Randalstown, Antrim  
 Bulwer, Wm. Lytton...Heydon Hall, Reepham  
 Bunbury, Sir C., Bart...Bury St. Edmund's  
 Bunbury, Henry M...Marlston House, Newbury  
 Bundy, Thomas...Eastleigh, Southampton  
 Bunning, T. W...34, Grey St., Newcastle-on-Tyne  
 Bunny, Major Edward John...Sleafold, Horsham  
 Bunsen, G...Bourg-Rheindorf, Bonn, Prussia  
 Burbery, J. J...Crofts, Alvestone, Stratford-on-Avon  
 Burchnell, Samuel...Cotton, Burton-on-Trent  
 Burd, Thomas A...Burcot, Wellington, Salop.  
 Burden, Rowland...Castle Eden, Stockton-on-Tees  
 Burdett, E...Manor Farm, Lyvedon, Thrapstone  
 Burdon, George...Heddon Ho., Newcastle-on-Tyne  
 Burgess, John...Edenham, Bourne  
 Burgess, William...Holborn Viaduct, E.C.  
 Burgoyne, Sir J. M., Bt...Sutton Park, Potton  
 Burkhill, E. W...Winteringham, Brigg  
 Burn, J.R. Scott, l, Linkfield, Musselburgh, Edinburgh  
 Burnard, Chas. F...Compton Villa, Plymouth  
 Burnell, Edward...Chappel, Halstead  
 Burnell, E. P...Winkburne Hall, Southwell, Notts.  
 Burnett, David...Ashley, Stockbridge, Hants  
 Burnett, Francis...Kingscote, Wotton-under-Edge  
 Burnett, Gregory...Dee Cottage, Flint  
 Burney, George...Millwall, E.  
 Burnham, W. H...LongCompton, Shipston-on-Stour  
 Burniston, R...Oil Mills, Henley-on-Thames  
 Burr, D. Higford...Aldermanstone Court, Reading  
 Burrard, Sir George, Bt...Walhampton, Lymington  
 Burrell, Charles...Thetford  
 Burrell, R...Westley Hall, Bury St. Edmund's  
 Burroughes, H. N...Burlingham Hall, Norwich  
 Burroughes, Rev. J...Lingwood Lodge, Norwich  
 Burroughes, Rev. T...Gazeley, Newmarket  
 Burrows, Richard...Ruddington, Notts.  
 Burrows, T. Ashe...Normanton-on-Trent, Newark  
 Burt, H. C...Witchampton, Wimborne  
 Burton, John...Gresford, Wrexham  
 Burton, R. H. L...Chilton Grove, Shrewsbury  
 Burt, J. B...Kettering  
 Bury, Charles...Nazing, Essex  
 Bush, John W...  
 Bushby, H. J...Henleaze, Kingston Hill, S.W.  
 Bushell, William...Poulton, Wingham, Kent  
 Butcher, Thomas...Selling, Faversham, Kent  
 Butcher, W...Bowling Green Farm, Ewell  
 Butcher, William...Gosmere, Selling, Faversham  
 Butler, Hon. C. L...Coton House, Rugby  
 Butler, Edward...Ewell Hall, Kelvedon, Essex  
 Butler, G. C...1, Harcourt Buildings, Temple  
 Butler, Capt. J...Kirby Ho., Inkpen, Hungerford  
 Butler, Paul...Down Ampney House, Cricklade  
 Butler, Richard...Radcliffe-on-Trent  
 Butler, Wm...Badminton, Chippenham  
 Buxton, W...Lime Tree Lodge, Rotherhithe, S.E.  
 Byford, William...The Court, Glemsford, Suffolk  
 Byrd, Charles...Littywood, Stafford  
 Byrd, David...Milford, Stafford  
 Byrd, Frederick...Dunston, Penkridge  
 Byron, John...Kirby Green, Sleaford, Lincoln

## C.

- Caborn, Richard S.... Denton, Grantham  
 Cabrera, General... Wentworth, Chertsey  
 Cadle, Clement... Clarence Street, Gloucester  
 Cadle, John... Ballingham Hall, Ross  
 Cadle, Miles... Stockton-on-Tees  
 †Cadle, Thomas... Longcroft, Westbury-on-Severn  
 Cadogan, Mrs.... Brinkburn Priory, Morpeth  
 Caffin, Peter... Hazelwick, Crawley  
 Caird, James... 3, St. James's Square, S.W.  
 †Calcraft, J. H., ... Kempstone, Corfe Castle  
 Caldecott, C. M.... Holbrook Grange, Rugby  
 †Caldecott, Thos... Rugby Lodge, Rugby  
 Caldwell, Bonham... Leominster  
 Caldwell, H. B.... Monkton Farleigh, Brdfrd.-on-Avon  
 †Calless, Wm.... Bodicote House, Banbury  
 Callender, Peter... Devonshire House, Birkenhead  
 †Calthorpe, Lord... Perry Hall, Stafford  
 †Calverley, C. C.... University Club, Edinburgh  
 †Calvert, Frederic...  
 Calvert, Dr. F. C.... Gibbon Street, Bradford  
 †Calvert, J. S.... Tothill Manor House, Alford  
 †Cameron, A. H. F.... Sheil Road, Liverpool  
 Cammell, C.... Norton Hall, Sheffield  
 Campaign, Joseph George... Cowbit, Spalding  
 Campaign, S. W.... Deeping St. Nicholas, Spalding  
 Campbell, A. J.... St. James's Pl., Fermoy, Ireland  
 Campbell, Sir A. T. C., Bart... Wyseby, Ecclefechan  
 Campbell, C. Lee, Thuraston Hall, Birkenhead  
 Campbell, R.... Buscot Park, Lechlade  
 Cane, Edward... Berwick, Lewes  
 Cane, Rev. T. C.... Brackenhurst, Southwell  
 Canning, George H.... Shottery, Stratford-on-Avon  
 Canning, Wm. Browne... Elston, Devises  
 Cannon, Joseph C.... Beckley, Oxford  
 †Cantrell, Charles Seward... Riding Court, Datchet  
 †Cantrell, H.... Bayliss Court, Slough  
 †Capel, Arthur... Bulland Lodge, Wiveliscombe  
 Capel, Wm.... The Grove, Stroud, Gloucestershire  
 Capper, R. Harcourt... N. Gate, St. Weonard's, Ross  
 Carding, F.... Combs Farm, Farnsfield, Southwell  
 †Cardwell, E. H.... 11, Cromwell Place, W.  
 †Carew, R. Russell... Carpenter's Park, Watford  
 †Carew, Thomas... Collipriest House, Tiverton  
 †Carew, W. H. Pole... Antony House, Devonport  
 †Carew-Gibson, G. C.... Sandgate Lodge, Steyning  
 Cargey, Gilbert... Kiplin, Catterick  
 Carlin, Wm., jun... Marsh Cott., Keyingham, Hull  
 Carlisle, Edward... Penrith  
 †Carnegie, David... Eastbury, Watford  
 Carnegie, Hon. J. J.... Fair Oak, Petersfield  
 †Carpenter-Garnier J... S. Sydenham, Tavistock  
 Carr, William... Dene Park, Tonbridge, Kent  
 †Carrington, T. S. T.... Eaton, Doveridge, Derby  
 Carrington, William T.... Hollington, Uttoxeter  
 Carrol, W. Hutchinson... Tulla House, Nenagh  
 Carruthers, G. Brockbank... Westburne Ter., Lancaster  
 Carson, James... Spinfield, Great Marlow  
 Carson, J. A.... La Belle Sauvage Yard, Ludgate Hill  
 †Carter, John Bonham, M.P.... Adhurst St. Mary's  
 †Carter, George John... Tatton Dale, Knutsford  
 Carter, J. Quartly... Arborfield, Reading  
 Carter, M. F.... Newnam, Gloucester  
 Carter, William... Boughton Blean, Faversham  
 †Cartwright, Col. H., M.P.... Kineton, Warwick  
 Cartwright, Robert... Wergs, Wolverhampton  
 Cartwright, Richard Aubrey... Edgcott, Banbury  
 †Cartwright, R. Norton... Flixton, Bungay  
 Cartwright, T.... Pillar Farm, Dunston, Lincoln  
 Cartwright, T. L. M.... Newbottle Manor Ho., Brackley  
 †Cartwright, T. W.... Ragnall Hall, Newton, Newark  
 Cartwright, Gen. W.... Weedon  
 †Cartwright, W. G., M.A.... Newport, Mon.  
 Cartwright, W. S.... Stow House, Newport, Mon.  
 Carver, Robert... Ingarsby, Leicester  
 Case, James... Upton, Reading  
 †Case, J. B.... Poulton Hey, Bebbington, Birkenhead  
 Case, Thomas H.... Testerton Hall, Fakenham  
 Casson, Joseph... Burgh-by-Sands, Carlisle  
 Casswell, George... Gosberton, Spalding  
 Casswell, John Henry... Laughton, Folkingham  
 Castellain, Alfred... Liverpool  
 Castle, George... Sutton, Stanton Harcourt, Eynaham  
 Castle, George R.... Bicester  
 Castletown, Ld. Granstown Man., Ballycola, Abbeyleix,  
 Castree, Josiah... College Green, Gloucester [Ireland  
 Catchpool, Edward... Feering Bury, Kelvedon  
 Cater, J. W.... West Lodge, Barnet, N.  
 †Cathcart, R.... Pitcairnie Ho., Auchtermuchty, Fife.  
 Catlin, R. Edgar... Humberston Road, Leicester  
 †Caulfield, St. George... Donamor Cas., Roscommon  
 †Cavan, Col. P. C....  
 Cave, Henry Haddon... Brigg  
 †Cavendish, Lt.-Col. W. H. F.... West Stoke, Chichester  
 Cawdor, Earl of... Stackpole Court, Pembroke  
 Cawley, Thomas... Nantwich  
 Cawton, Wm. J.... Park Hall, Chesterfield  
 Cayley, Sir Digby, Bart.... Brompton, York  
 Chadburn, Frank... Coekcliffe Hill, Arnold, Notts.  
 Chadwick, E. C. B.... Park Cottage, East Sheen, S.W.  
 †Chadwick, Elias... Padleston Court, Leominster  
 †Chadwick, F.... The Hermitage, Grimsargh, Preston  
 Chadwick, T.... Wilmslow Grange, Cheshire  
 †Chafy, Westwood W.... Bowes House, Ongar  
 Chalcraft, H.... Millhall Cottage, Alton  
 Chalcraft, William... Bramshot House, Liphook  
 Chalk, Thomas... Barbourne, Worcester  
 Challenor, John... Blackpole, Leek  
 Chaloner, Admiral... Longhull, Guisborough  
 Chamberlain, Henry, jun... Bredicot Court, Worcester  
 †Chamberlayne, T.... Cranbury Park, Winchester  
 Chamberlain, W.... Adderbury, Banbury  
 Chambers, George... High Green House, Sheffield  
 Chambers, John... The Hurst, Tibshall, Alfreton  
 Chambers, P. H.... Llysmeirchion, Trefnant, Rhyl  
 Chambers, Thomas, jun... Colkirk Hall, Fakenham  
 †Chambers, Wm.... Hafod, Rhayader  
 Champion, Wm. W.... Calcot, Reading  
 Champney, Felix... Gatwick, Crawley, Sussex  
 Champneys, Rev. T. P.... Badsworth, Pontefract  
 Chandler, Henry... Salford, Manchester  
 Chaplin, J. R.... Three Chimneys, Ridgewell, Haistead  
 Chapman, R. H.... Upton, Nuneaton  
 Chapman, Thos... 14, Cockspar St., Charing Cross, S.W.  
 Chapman, Capt. W. H.... Enderby, Leicester

Upman, W... S. Pancras Ho., Orwell Pl., Ipswich  
 Upman, William... Apethorpe, Peterborough  
 Charlemont, Earl of... Charlemont House, Dublin  
 Charles, James... Home Farm, Hursley Pk, Winchester  
 Charlesworth, J... Middlestown, Wakefield  
 Charlesworth, J. Barff... Hatfield Hall, Wakefield  
 Charley, Richard...  
 Charlton, St. John... Pentrefynon,, Holywell  
 Charlton, St. J. C... Apley Cas., Wellington, Salop  
 Charlton, W. H... Hesleyside, Hexham  
 Charteris, Hon. F... Eccles Hall, Attleborough  
 Chase, Henry... Stanton Hall, Ixworth, Suffolk  
 Chaddock, H. H... Solihull, Warwickshire  
 Chawner, Henry... Hound Hill, Uttoxeter  
 Chawner, Richard... Hare Hill, Doveridge, Derby  
 Chawner, Richard Croft... The Abnalls, Lichfield  
 Cheate, T. Farmer... Dosthill, Tamworth  
 Cheere, Rev. Frederic... Papworth Hall, St. Ives  
 Cheesman, Frederick... Little Chart, Ashford  
 Chetham, Henry... Woodthorpe, Nottingham  
 Chiffins, Henry... Little Easton Manor, Dunmow  
 Chisney, Edward... Gadsley Hall, Melton Mowbray  
 Chissey, Geo. Charles... Denford House, Hungerford  
 Chisworth, Joseph... Longslow, Market Drayton  
 Chitwode, Sir J. N. L., Bart... Oakley, Mkt. Drayton  
 Chitwynd, Sir G., Bart... Grendon Hall, Atherstone  
 Chitwynde, Major W. F... Brocton Hall, Stafford  
 Chirk, John... Compton Valence, Dorset  
 Chirk, Thomas... Stratton, Dorchester, Dorset  
 Chillingworth, John... Horsepath, Oxford  
 Chinery, John... Wootton Milton, Lymington  
 Chittenden, James... Hope All Saints, New Romney  
 Chittenden, John... Newchurch, New Romney  
 Chitty, Edward... Guildford  
 Cholmley, Sir George, Bart... Howsham, York  
 Cholmley, H. W... Newton Hall, Rillington, Yorks.  
 Cholmondeley, Lord H... Holly Hill, Southampton  
 Cholmondeley, Col. Hon. G... Abbott's Moss, Nthwch.  
 Christie, James, jun... Boynton Hall, Chelmsford  
 Church, John... Woodside, Hatfield  
 Churchill, George... Aldershot, Fordingbridge  
 Churchill, Lord...  
 Churchill, H... Barton Ho., Morchard Bishop, Devon  
 Churchton, John... Foregate Street, Chester  
 Churchute, W. L. Wiggett... The Vyne, Basingstoke  
 Church, Charles L... Higher Broughton, Manchester  
 Church, W. Harcourt... Twycross, Atherstone  
 Clarence, John...  
 Clarina, Lord... Elm Park, Limerick, Ireland  
 Clark, Geo. Wm... Steellands, Ticehurst, Sussex  
 Clark, Joseph H... Attwood House, Maidenhead  
 Clark, Thomas... Derndale, Hereford  
 Clark, William... Luney Barton, St. Ewe, Cornwall  
 Clark, William J... Elm Lodge, Reading  
 Clarke, C... Ashby-de-la-Lound, Sleaford  
 Clarke, Charles F... Perton Grove, Wolverhampton  
 Clarke, E. C... Manor Farm, Haddenham, Thame  
 Clarke, Edw. S... Glebeland House, Lee, Kent  
 Clarke, G. R... Chesterton Lodge, Bicester  
 Clarke, John... The Roos, Saffron Walden  
 Clarke, John Algernon... Long Sutton  
 Clarke, Jno. Sanders... Prating Hall, Lutterworth  
 Clarke, Jno. William... Guisborough, Yorkshire

Clarke, Nathaniel... Beamish Park, Fence Houses  
 †Clarke, Robt. B... Haynes Hill, Barbadoes  
 †Clarke, T. E... Tremlett House, Wellington, Som.  
 Clarke, Thomas T... Swakeleys, Uxbridge  
 Clarke, William... Brack Farm, Luton  
 Clarke, W. B... Barwickstead, Berkermet, Carnforth  
 †Clavering, Sir W., Bt...  
 †Clay, Charles... Walton Grange, Wakefield  
 Clay, Charles, Whitechurch, Salop.  
 Clay, John... Kinsale, Whittington, Oswestry  
 †Clayden, John Carter... Hadley, Barnet  
 †Clayton, E. E... Guildhall St., Bury St. Edmund's  
 Clayton, David S... Norbury, Stockport  
 Clayton, John... Newcastle-on-Tyne  
 †Clayton, Nathaniel... Newland House, Lincoln  
 Clayton, R. C. B... 35, Clarendon Square, Leamington  
 Clayton, T. G... Ousecliffe, York  
 Cleasby, R. H... Broomside House, Durham  
 Cleasby, Thomas M... Wilton Grange, Reicar  
 Cleave, Benjamin W... Newcombe House, Crediton  
 Cleminson, Robert... Endon, Stoke-on-Trent  
 Clerk, Arthur... The Mead, Chepstow  
 †Clerk, E. H... Burford, Shepton Mallet  
 Clews, R. T... The Woodlands, Weston, Shifnal  
 Cliffe, Thomas... Crewe Gates, Crewe  
 Clift, Samuel... Fordhouse Mill, Wolverhampton  
 Clifton, T. H... Lytham Hall, Lytham, Lancashire  
 †Clinch, Charles... Eagle Brewery, Witney  
 Clinton, Col. Fred... Ashley Clinton, Lymington  
 †Clinton, Lord... Heanton Satchville, Beaford  
 Clive, George... Perrystone, Ross  
 Clive, Capt. Hon. W. W., M.P... 53, Grosvenor St., W.  
 †Clonbrock, Lord... Clonbrock, Ahaserah, Ireland  
 †Clowes, Edmund... Carnforth, Lancaster  
 Clowes, George... Oak Hill, Surbiton  
 Clowes, Wm... 51, Gloucester Ter., Hyde Park, W.  
 Clutterbuck, Rev. J. C... Long Wittenham, Abingdon  
 Clutterbuck, R... 8, Gt. Cumberland Pl., Hyde Pk.  
 Clutterbuck, T... Warkworth, Aclington  
 Clutton, Henry... 9, Whitehall Place, S.W.  
 Clutton, John... 9, Whitehall Place, S.W.  
 †Clutton, John Henry... 9, Whitehall Place, S.W.  
 Clutton, Robert... Hartswood, Reigate, Surrey  
 Clutton, Robt. G... 9, Whitehall Place, S.W.  
 †Clutton, Wm. James... The Mount, York  
 Coaker, George... Old Newnham, Plympton  
 Coatsworth, J... West Wickham, Bromley  
 Cobb, Frederick... Walton, Warwick  
 Cobb, Geo. Henry... Oakwood, Upper Norwood, S.E.  
 †Cobb, Henry... 26, Lincoln's Inn Fields, W.C.  
 Cobb, John... Sheldwick, Faversham  
 Cobb, Robert L... Higham, Rochester  
 Cobb, Thomas... Radnor Cliff Villa, Sandgate  
 Cobbett, John M... Skeynes, Edenbridge  
 Cobbold, John Chevallier... Ipswich  
 †Cobbold, John Patterson, Ipswich  
 Cobon, James... Well Hall, Lynn  
 †Cochrane, A. H... Langton Grange, Darlington  
 Cochrane, James... Harburn, Edinburgh  
 Cockburne, G... Newcastle-on-Tyne  
 Cocking, W. F... Curlew House, Crowle, Doncaster  
 †Cocks, Rev. C. R. Somers... Neen Savage Rectory,  
 Cleobury Mortimer

- Cocks, Charles...Packington, Lichfield  
 Cocksedge, James S....Stowmarket  
 Codd, H....Beenharn Lodge, Aldermaston, Reading  
 †Coke, Hon. E. K....Longford Hall, Derby  
 Coldham, H. W....Anmer, Lynn, Norfolk  
 †Cole, R. J....  
 Cole, Robert...Belmont, Wragby  
 †Cole, William Douglas...Bicester  
 Coleberd, Robert...Purewell Farm, Christchurch  
 Coleman, G. W., Great Glen, Leicester  
 Coleman, H. Septimus...Chelmsford  
 Coleman, John...Escrick Park, York  
 Coleman, John...Park Nook, Quorndon, Derby  
 Coleman, Richard...Langdon Abbey, Dover  
 †Coles, Alfred...Clifton Lodge, Clapham Park, S.  
 Coles, Walter...Bushy Lodge Farm, Watford  
 Coley, Henry...Neachley Hall, Shifnal  
 Collier, W. F....Woodtown, Horrabridge, S. Devon  
 Collin, Rev. J., jun...Rickling Vicarage, Herts.  
 Collings, Rev. William T....Guernsey  
 Collins, Charles...Burbage, Hinckley  
 †Collins, Henry...Aldsworth House, Emsworth  
 †Collins, John...Wonham, Bampton, Devon  
 Collins, Wm....Aston Farm, Stafford  
 Collison, William...Beverley  
 Collyer, Rev. Canon R...Warham Rect., Wells, Norf.  
 Colman, Samuel...Willy Hall, Attleborough  
 Colman, Thos. H....Rockland St. Peter, Attleborough  
 Colman, J. James, M.P....Carrow House, Norwich  
 Colthurst, John...Chew Court, Chew Magna, Bristol  
 Colville, Gen...Kempsey House, Worcester  
 Colville, C. R....Lullington Hall, Burton-on-Trent  
 †Colvin, B. B...Monkhams Hall, Waltham Abbey  
 †Colyer, William...North End, Crayford, Kent  
 Combe, R. H....Pierpoint, Frensham, Farnham  
 Combe, Thomas...Oxford  
 †Comber, Thomas...Redcliffe, Newton-le-Willows  
 †Combermere, Visc...Combermere Abbey, Nantwich  
 †Compton, H. C...Minstead Manor House, Lyndhurst  
 Compton, T...Fisherton Delamere, Heytesbury  
 Coney, William...Battenhall, Worcester  
 †Congreve, S. B....Harbors Magna, Rugby  
 †Congreve, T...Peter Hall, Brinklow, Coventry  
 †Congreve, Walter...  
 Conington, Clement...Hagworthingham, Spilsby  
 †Constable, Sir Clifford, Bart....Burton Constable,  
 Hull  
 Constable, Rev. J....R. A. College, Cirencester  
 Conway, Wm. S....Bodryddan, St. Asaph's, Flints.  
 Cook, George...Flitwick, Ampthill  
 Cooke, B. G. D....Colomendy, Mold  
 Cooke, Chas...Livermere Parva, Bury St. Edmund's  
 Cooke, Frederick T...Caston Hall, Attleboro'  
 Cooke, G....Horseheath Pk. Farm, Linton, Cambs.  
 †Cooke, Henry...138, Widemarshe Street, Hereford  
 Cooke, James H....Berkeley Castle, Gloucestershire  
 Cooke, John...Mill Moor, Macfeen, Malpas  
 Cooke, Rev. James Y....Semer, Ipswich  
 Cooke, Robert C....Livermere, Bury St. Edmund's  
 Cooke, William...The Green, Skelsley, Worcester  
 †Cooke, Wm. Fothergill...  
 Cooke, Wm. R....Rickenhall, Botesdale, Suffolk  
 Cookes, Jno. M....32, Warwick St., Leamington  
 Cooke, John R....Wood House, Stourport  
 †Cookson, John...The Firs, Stretford, Lancashire  
 Cookson, W. J....Denton Park, Otley, Yorkshire  
 Cooper, Alfred Allen...The Hall, Wigston, Leicester  
 †Cooper, C. B....Fakenham Hall, Ixworth  
 Cooper, E. H...Markree Castle, Collonee, Sligo  
 Cooper, G. Kersey...Bowbeck House, Ixworth  
 Cooper, Henry Reeve...Britwell, Watlington, Oxon.  
 Cooper, J. R...Barton, Bury St. Edmund's  
 †Cooper, N. J...Westgate, Mansfield  
 Cooper, Thomas W...Bury St. Edmund's  
 Cooper, W. W...Barnham, Thetford  
 Coote, Geo. Cosens...Tortington, Arundel  
 Cope, T. Berwick...Tettenhall, Wolverhampton  
 Copeman, George...Dunham Lodge, Swaffham  
 Coppeake, Thos. G...Brailsford, Derby  
 †Coppard, T...Laneshurst Lodge, Hurstpierpoint  
 Corbet, H...Farmers' Club, Salisbury Square, E.C.  
 †Corbet, H. R...Adderley Hall, Market Drayton  
 Corbett, C...Broad Marston, Stratford-on-Avon  
 Corbett, James...Croome Dabitop, Severn Stoke  
 †Corbett, Capt. R. J...Newland, near Coleford  
 Corbett, Thomas...Shrewsbury  
 Corbett, W. A...Dumbleton, Evesham  
 Corder, Edward...Writtle, Chelmsford  
 Corden, Arthur H...Brincton, Shifnal  
 Corden, John...Great Chatwell, Newport, Salop.  
 Corner, Edward...Esk Hall, Whitby  
 Cornish, G...Risby Gate St., Bury St. Edmund's  
 Corringham, R. W...Lound House, Haxey, Bawtry  
 Coryton, A...Pentillie Castle, Saltash, Cornwall  
 †Cosby, H. G...Stradbally Hall, Queen's County  
 Costerton, Charles Fisher...Scole  
 Cother, William...Middle Aston, Woodstock  
 †Cotta, Baron G...Hipfeldorf, Heilbronn, Germany  
 Cottam, George H...Old St. Pancras Road, N.W.  
 †Cotterell, Sir H. G. Bart...Garnons, Hereford  
 †Cotterell, Jacob Henry...6, Terrace Walks, Bath  
 Cottingham, J...4, St. James's Square, Manchester  
 Cottingham, John G...Chatsworth, Chesterfield  
 Cottle, George...West Felton, Shrewsbury  
 †Cotton, Alexander...  
 Cotton, Gen. F. Conyers...Cilhendre, Rhuabon  
 Cotton, H. P...Quex Park, Isle of Thanet  
 †Cotton, Hon. R. W. S...Bowlton Park, Shrewsbury  
 †Couchman, C...Temple Balsall, Birmingham  
 Couchman, J. W...7, Stanley Villas, Pembury  
 Road, Tottenham  
 Coulman, Edward...The Levels, Thorne, Yorkshire  
 Coulman, John...Red House, Thorne  
 Coultas, James, jun...Spittlegate, Grantham  
 †Coulthard, G...Lanercost Abbey, Brampton  
 Coupland, John G...Freeston, Boston  
 †Court, P. Simpson...140, Snargate Street, Dover  
 Courthope, G. C...Whilgh, Hurst Green  
 Cousins, Richard...Whitehaven  
 Coussmaker, Lannoy...Westwood, Guildford  
 Coventry, Earl of...Croome Court, Kempsey  
 †Cowley, W. Payne...Ashby St. Ledgers, Rugby  
 Cowper, E. A., C. E...6, Great George Street, S.W.  
 †Cox, Henry...Trevereux, Edenbridge, Kent  
 Cox, Samuel Walker...Spondon Cottage, Derby  
 Cox, William...Brailsford, Derby

ox, W. S. . . . Sansom Wood, Calverton, Nottingham  
 ox, Wm. Thos. . . . Spondon Hall, Derby  
 Coxe, James . . .  
 oxon, John . . . Freeford Farm, Lichfield  
 raddock, R. . . . Lyneham, Chipping Norton, Oxford  
 ragg, W. Smith . . . Arkholme, Lancaster  
 raigie, P. G. . . . Hartley Ho., Lower Heath, Hampstead  
 rane, Edward . . . Forton, Montford, Shrewsbury  
 rane, James . . . Tolpudde, Dorchester  
 rane, Joseph . . . Calcot, Shrewsbury  
 Cranfield, William . . . Buckden, Huntingdon  
 ranke, John . . . Fountain Street, Ulverston  
 Cranston, Thomas . . . Little Dilwyn, Leominster  
 raven, J. . . . Whalley Range, Manchester  
 rawford, John . . . Lumley Park, Fence Houses  
 rawford, Wm. H. . . . Lakelands, Cork  
 Crawhall, G. . . . West Bank, Mansfield, Notts.  
 Crawley, John, jun. . . . Gosberton Fen, Spalding  
 Crawley, J. R. . . . Melchbourne, Grange, Bedford  
 Crawley, John S. . . . Stockwood Park, Luton  
 rawley, Lewis . . . Keightley House, Holbeach  
 reese, William . . . Teddington, Tewkesbury  
 ressingham, Jonah . . . Carshalton, S.E.  
 resswell, A. J. Baker . . . Cresswell, Morpeth  
 resswell, Mrs. Gerard . . . Appleton Hall, King's Lynn  
 reswell, R. W. . . . Ravenstone, Ashby-de-la-Zouch  
 rewe, Sir J. H., Bart. . . . Calke Abbey, Derby  
 rewe-Read, Capt., R.N. . . . Llandinam, Montgomery  
 rickmore, W. . . . Seething, Brooke, Norfolk  
 ripwell, John . . . Epperstone, Southwell, Notts.  
 risp, Arthur Wm. . . . Gedgrave Hall, Woodbridge  
 risp, Edwards, M. D. . . . 42, Beaufort Street, S.W.  
 ritchley, Walter R. . . . Salwick Hall, Preston  
 Croft, A.H. . . . Aldborough, Boroughbridge, Yorkshire  
 Croft, Sir John, Bart. . . . Kingsdown, Sittingbourne  
 'roft, J. . . . Dalton Ho., Saddington, Mkt. Harboro'.  
 Crofts, Rev. C. D. . . . Caythorpe Rectory, Grantham  
 'rofts, John . . . Long Lawford Hill, Rugby  
 Crofts, Lieut. R. B., R.N. . . . Great Cozens, Ware  
 'rompton, George . . . Chesterfield  
 'rompton, John George . . . Derby  
 'roome, J. Capel . . . Bagendon House, Cirencester  
 Cropper, E. Wm. . . . West Highfield, Talbot Road, Oxton, Birkenhead  
 'rosbie, Wm. T. . . . Ardferit Abbey, Tralee, Ireland  
 'rosby, J. M. . . . 73, Newboro' Street, Scarborough  
 'rosland, Jabez . . . Clumber Street, Nottingham  
 'ross, John . . . 78, Cross Street, Manchester  
 Cross, Wm. A. . . . Red Scarr, Preston, Lancashire  
 'rosse, Thomas B. . . . Shaw Hill, Chorley  
 'rosskill, Alfred . . . The Iron Works, Beverley  
 Crossley, Sir F., Bt., M.P. . . . Somerleyton, Lowestoft  
 'rosthwaite, Peter . . . Monk Hall, Keswick  
 'roundon, John . . . Urswick, Ulverstone  
 'Crow, G. . . . Ornham, Boroughbridge, Yorkshire  
 'rowdy, G. Frederick . . . Faringdon, Berks.  
 'rowe, Daniel . . . Gaywood, King's Lynn  
 'rowley, John L. . . . Standford Hall, Newport, Salop.  
 'roysdale, John . . . Whitley Bridge, Pontefract  
 'Crump, G. W. . . . Woollas Hill, Eckington, Pershore  
 'rundwell, G. . . . Rose Mount, Ilfley, Oxford  
 'rutchley, P. H. . . . Sunninghill Park, Staines

Cuff, J. H. . . . New Cattle Market, Islington, N.  
 †Cuff, W. Fitchett . . . Merriott, Taunton  
 Culley, George . . . Fowberry Tower, Belford  
 Culshaw, Joseph . . . Towneley, Burnley  
 Cumberbatch, L. . . . Queen's House, Lyndhurst  
 †Cumming, L. . . . Ratten, Thurso, N.B.  
 †Cummins, John, jun. . . . Nelfields, Newent  
 Cumpston, Joseph H. . . . Barton Hall, Penrith  
 Cunningham, Capt. R. D. B. . . . Hensol, Castle-Douglas  
 Cunliffe, Maj. Ellis . . . Queen St., Lytham  
 †Cure, Capel . . . Blake Hall, Ongar, Essex  
 Cureton, George . . . Beam House, Shrewsbury  
 Currie, Edmund . . . West Burton House, Petworth  
 Currie, Henry . . . West Horsley Park, Leatherhead  
 Currie, Raikes . . . Minley Manor, Farnborough  
 Curtis, Charles E. . . . Alton  
 Curtis, Thomas . . . The Hall, Berkhamstead  
 †Curtis, Sir Wm., Bart. . . . Caynham Court, Ludlow  
 Curtler, T. G. . . . Bever House, Worcester  
 Curzon, Hon. S. C. H. R. . . . Grove Ho., Tooting, S.W.  
 Cust, Capt. F. Henry . . . Ellesmere  
 Custance, Hambleton F. . . . Weston House, Norwich  
 Cuthbert, Robert . . . Newton-le-Willows, Bedale  
 †Cuthbert, William . . . Beaufront, Hexham  
 Cutting, Robert Coote . . . Ridlington, Uppingham  
 Czarnecki, Lieut. Arthur . . .

D.

Dacre, Lord . . . The Hoo, Welwyn, Herts.  
 †Dacre, Henry . . . Auckland, New Zealand  
 †Dacre, Rev. W. . . . Irthington Vicarage, Carlisle  
 Daglish, R. . . . Aston Hall, Preston Brook  
 Daintree, J. O. . . . The Grange, Lolworth, St. Ives  
 Daintree, G. E. . . . Fenton, Warboys, Huntingdon  
 Dalton, James . . . Fillingham Manor, Lincoln  
 Dalton, P. . . . Cummersdale, Carlisle  
 Dalton, Rev. R. . . . Kelmarsh, Northampton  
 Dalzell, Anthony . . . Stainburn Hall, Workington  
 Dalzell, John . . . Papcastle, Cockermouth  
 Danby, Francis . . . Middledale, Driffield  
 Daniel, Thomas . . . Stoodleigh, Tiverton  
 Danson, J. T. . . . Carnsdale Farm, Barnston, Birkenhead  
 †Darbishire, S. D. . . . Pendyffryn, Conway  
 †Darby, Alfred . . . Stanley Hall, Bridgnorth  
 Darby, George . . . Markly, Warbleton, Hurst Green  
 †Darby, Abraham . . . Ebbw Vale Pk., Newport, Mon.  
 Darley, Chas. Albert . . . Burtonfield, York  
 †Darling, J. . . . Beau Desert, Rugeley  
 Darling, Robt. . . . Plawsworth, Fence Houses  
 †Dashwood, F. Loftus . . . Kirtlington Park, Oxon.  
 Dashwood, Sir Henry W. . . . Kirtlington, Oxford  
 †Dashwood, M. . . . 22, Park Lane, W.  
 Daubeny, Rev. E. A. . . . Ampney, Cirencester  
 Daubeny, R. . . . 2, King's Bench Walk, Temple, E.C.  
 †Davenport, F. H. . . . Headington Hill, Oxford  
 Davey, Charles M. . . . Witham  
 Davey, H. M. . . . Beverley Villas, Colchester  
 Davey, John G. Ellis . . . Horningtoft, Letcham  
 †Davey, J. S. . . . Redruth, Cornwall  
 Davey, Richard . . . Bochym House, Helstone

- David, Edward...Llandaff  
 David, Evan William...Radyr Court, Cardiff  
 Davie, Sir H. Ferguson, Bt., M.P...Creedy, Crediton  
 Davie, J. Thornton...Hepscott Red House, Morpeth  
 Davies, Benjamin...Hayton House, Chorley  
 Davies, D. Price...Troedybryn, Llandilo  
 †Davies, E. H....  
 Davies, George R...Mere Old Hall, Knutsford  
 Davies, Rev. J...Moor Court, Kington, Herefordshire  
 †Davies, James...Bollington, Altrincham  
 Davies, James...Isle Park, Shrewsbury  
 Davies, John Morgan...Froodvale, Llandilo  
 Davies, L. T...Llyncubing, Llanpumpsaint  
 Davies, Robert C...Southminster, Maldon  
 Davies, Robert J...Cwrtrmaur, Llangeitho, Lampeter  
 †Davies, Robt. P...Ridgeway, Narberth, S. Wales  
 Davies, Mrs. Susanna...Rochlavenston Manor, Notts.  
 Davies, Thomas...Burlton Court, Burghill, Hereford  
 Davis, Evan H...Patton, Much Wenlock  
 Davis, Henry...Old Downs, Oakhill, Bath  
 Davis, John...Wykin Hall, Hincley  
 Davis, Peter...Bickmarsh Hall, Alcester  
 †Davis, R...9, St. Helen's Place, Bishopsgate, E.C.  
 †Davis, R. F....  
 †Davis, R. S. B...Swerford Park, Enstone, Oxon.  
 †Davis, Samuel...Swerford Park, Enstone, Oxon.  
 Davis, Stephen...Woolashill, Pershore  
 Davis, T...Little Wenlock, Wellington, Salop.  
 †Davis, Thomas Henry...Orleton, Worcester  
 Davison, John Perry...Easton Maudit, Northampton  
 Davison, Richard...Driffield  
 Davy, Jas...Flitton Barton, North Molton  
 Davy, John...Owersby, Market Rasen  
 Davy, John T...Barton Rossash, South Molton  
 Davys, W. H. C...Nenadd-fawr, Llandovery  
 Dawson, Edward...Aldcliffe Hall, Lancaster  
 Dawson, George...Thorncliffe, Sheffield  
 Dawson, J...Gronant, Rhyl, Flintshire  
 †Dawson, Wm. Edward...Plumstead Common, S.E.  
 †Day, Charles...Easton, Stamford  
 Day, John...High Street, Whitchurch, Salop.  
 Day, John...Newick Lodge, Uckfield  
 †Day, Nevile...Easton, Stamford  
 Day, Richard...Hodroyd Hall, Barnsley  
 †Day, Samuel...St. Neot's  
 Day, Thomas...22, Dorset Street, Baker Street, W.  
 †Day, William...Woodyates, Salisbury  
 †D'Azy, Count Benoist...88, Rue de Grenelle, Paris  
 †Deacon, John...Mableton, Tonbridge  
 †Dean, A. K...East Brent, Axbridge, Somerset  
 †Dean, F. K...East Brent, Axbridge, Somerset  
 Dean, H. C...North Stonham Park, Southampton  
 Dean, James...Brereton, Rugeley  
 Dean, Thomas...Mold  
 Deane, Patrick, High Street, Hull  
 †Decanville, M...Petit Bourg, Corbeil  
 †Decanville, M. Paul...Petit Bourg, Corbeil  
 †De Curzay, Visct...Château de Curzay, Lusignan  
 Deedes, Lieut.-Col. Wm...Sandling Park, Hythe  
 †Dees, James...Flora Villa, Whitehaven  
 †Dees, Ringford R...Wallsend, Newcastle-on-Tyne  
 †De Kergolay, Count...Camisy (Manche)  
 Delano, William H...59, Rue de la Victoire, Paris  
 †De L'Isle and Dudley, Lord...Penhurst Park, Ke  
 Delves, William...Frant, Tunbridge Wells  
 †De Monicault, E...127, Boulevard Haussman, Par  
 De Mornay, Alfred...Cold Harbour, Wallingford  
 Denchfield, J...Aston Abbots, Aylesbury  
 Denison, Edmund...Doncaster  
 Denman, Lord...Middleton Hall, Bakewell  
 Denne, W...Three Counties Asylum, Arlesey, Bed  
 †Dennett, Mullens...Lodsworth, Petworth, Sussex  
 Dennis, Henry...Hafod-y-bwch, Rhuabon  
 Denson, Samuel...Pwlhalog Hall, Rhyl, Flints.  
 †Dent, John Coucher...Sudely Castle, Winchcom  
 †Dent, John D., M.P...Ribstone Hall, Wetherby  
 Dent, Joseph...Ribstone Hall, Wetherby  
 Dent, Ralph...Streatham Castle, Barnard Castle  
 †Dent, Wilkinson...Flass Ho., Kirkby Thore, Penrit  
 †Denton, J. Bailey...Orchard Court, Stevenage  
 Denton, A. Bailey...Stevenage, Herts.  
 Denton, Edward H...Gt. Barton, Bury St. Edmund  
 Denton, Henry...Wolverhampton  
 De Pass, D...9, Delamere St., Westbourne Sq., W  
 †Derby, Earl of...Knowsley, Prescot  
 Derham, James...St. Thomas's Road, Chorley  
 †Derham, William...Tottenham  
 De Rothschild, Sir A., Bt...Aston Clinton, Tring  
 Des Vouex, Sir H., Bt...Drakelow Pk., Burton-on-Tren  
 †De Schroder, Baron...The Dell, Windsor  
 †De Trafford, Sir H., Bt...Trafford Pk., Manchester  
 †Deusy, Ernest...Chateau de la Pacandière, Franc  
 Devas, Charles F...Bromley Lodge, Kent, S.E.  
 Devas, Thomas...Mount Ararat, Wimbledon, S.W  
 Devas, William...Woodside, Old Windsor  
 Devaux, A...20, Avenue-rd., St. John's Wood, N.W  
 Deverell, John...Purbrook Park, Portsmouth  
 †De Vibreay, Marquis...Chateau de Chaverny, Franc  
 †De Vitre, H. D...Charlton House, Wantage  
 †De Vogüé, Count Ch...37, Rue de Bourgogne, Paris  
 †De Vogüé, Marquis...Rue Tabert (2) Paris  
 †Devon, Earl of...Powderham Castle, Exeter  
 Dew, Tomkyns...Whitney Court, Hereford  
 De Wend, F. W...Underbank Hall, Sheffield  
 †De Westphalen, Count Clemens...Laer, via Cologne  
 †De Wezele, Count G...55, Eaton Square, W.  
 †Dewing, R...Carbrooke, Watton, Norfolk  
 De Winton, Capt. T...Wallsworth Hl., Gloucester  
 Deykin, James, jun...Whiston, Penkridge  
 Diamond, James...The Beeches, Axminster  
 Dicken, Thomas, jun...Colton Hall, Rugeley  
 †Dickens, Charles Scrase...Horsham, Sussex  
 Dickens, R. A...Woodford Grange, Wolverhampton  
 †Dickers, Samuel S...Golder Manor, Tetsworth  
 Dickin, E. T...Yockingsgate, Whitchurch, Salop.  
 Dickin, John...Tyndwfr, Llangollen  
 Dickin, Wm...The Lloyd, Market Drayton  
 Dickinson, G. T...Wheelbirks, Stocksfield  
 †Dickinson, E. H...Berkeley, Frome  
 Dickinson, William...New Park, Lymington  
 †Dickons, Thomas...High Oakham, Mansfield  
 Dickson, Arthur...Queen's Park, Chester  
 †Dickson, G. A...Newton Nurseries, Chester  
 Digby, G. D. Wingfield...Sherborne Castle, Dorset  
 Digby, Rev. K...Tetteshall Rectory, Litcham, Norf.  
 Digby, Lord...Minterne House, Dorchester, Dorset



Milke, Sir C. W., Bt., M.P. . . . 76, Sloane St., S.W.  
 Minning, J. . . . Adderstone, Belford, Northumberland  
 Minning Joseph . . . Langley Hill Top, Haydon Bdge.  
 Israeli, Rt. Hn. B., M.P. . . . Hughenden, Bucks.  
 Ivett, John . . . Bovey Tracey, Devon.  
 Dixon, George M. . . . Bradley Hall, Ashbourne  
 Dixon, Henry . . . Frankham, Tunbridge Wells  
 Dixon, John Thomas . . . Walwick Grange, Hexham  
 Dixon, John W. . . . Caistor, Lincolnshire  
 Dixon, Thos. John . . . Holton, Caistor, Lincolnshire  
 Dixon, Thos. Parkinson . . . Caistor, Lincolnshire  
 Dobbs, Samuel Friday . . . Huntly, Gloucester  
 Dobbell, G. C. . . . 10, North John Street, Liverpool  
 Dobbell, Joseph . . . Leftwich, Northwich  
 Dodd, Whitehall . . . Llannerch Park, St. Asaph  
 Dodd, Francis . . . Rush Court, Wallingford  
 Dodd, H. . . . The Hall, Rothefield, Tunbridge Wells  
 Dodds, T. P. . . . Anick Grange, Hexham  
 Dodson, Charles E. . . . Littledale Hall, Lancaster  
 Doggett, Arthur . . . Newnham, Baldock  
 Doggett, Thomas William . . . Sandon, Royston  
 Doneraile, Viscount . . . Doneraile Court, Co. Cork  
 Donkin, Samuel . . . Bywell, Felton, Northumberland  
 Donovan, George (49th Regt.) . . .  
 Dorell, Thomas . . . Bishampton, Pershore  
 Dorrington, C. . . . Bridehall Farm, St. Albans  
 Dorrington, C. H. . . . Otterburne, Winchester  
 Dorrner, C. Cottrill . . . Rousham, Woodstock, Oxon.  
 Dousleday, Dr. . . . Long Clawson, Melton Mowbray  
 Douglas, J. Byrant . . . Hampden Street, Nottingham  
 Dowden, Thomas . . . Roke Farm, Bere Regis  
 Dowdeswell, A. C. . . . Pall Court, Tewkesbury  
 Dowdeswell, Benjamin . . . Castle Eaton, Fairford  
 Dowdeswell, W. E., M.P. . . . Pall Court, Tewkesbury  
 Dowling, Edwyn . . . 15, Vineyards, Bath  
 Downing, Isaac . . . Turner's Hill, Rowley Regis, Dudley  
 Downing, J. B. . . . Holme Lacey, Hereford  
 Downing, John . . . Ashfield, Fermoy, Ireland  
 Downing, J. Marshall . . . Dowles, Bewdley, Salop.  
 Downs, J. H. . . . Grove Lodge, Fulham, S.W.  
 Downward, Rev. George R. . . . Shrewsbury  
 Downse, W. T. . . . Chelsfield Hall Fm, Orpington, Kent  
 Doyle, John A. . . . Plás Dulas, Abergele  
 Drake, Sir T. T. F. E., Bart. . . . Nutwell Court, Exeter  
 Drake, T. Tyrwhitt . . . Shardloes, Amersham  
 Drakeford, David . . . Brookside, Crawley, Sussex  
 Drakeper, Charles . . . Clinton House, Kenilworth  
 Drax, J. S. W. Erle . . . Charborough Park, Blandford  
 Drew, Edw. . . . Calcot, Kingscote, Wootton-under-Edge  
 Drew, James . . . Artiseombe, Tavistock  
 Dreyer, E. Simcoe . . . The Grange, Honiton  
 Dreyer, George . . . Manor Farm, Oving, Chichester  
 Dreyer, Henry . . . Milvill Farm, Titchfield  
 Dreyer, John . . . North Stoke, Arundel  
 Dreyer, R. Dawtrey . . . Peppering, Arundel  
 Dreyer, Thomas . . . Piccard's Farm, Guildford  
 Dreyer, G. . . . Holker, Grange, Lancashire  
 Dreyer, Robert Collin . . . 4, Whitehall Place, S.W.  
 Druce, A. F. Milton . . . Twelve Acres, Eynsham, Ox.  
 Druce, Joseph . . . Eynsham, Oxford  
 Druce, Samuel . . . Eynsham, Oxford  
 Druce, S. Benj. L. . . . New University Club, S.W.  
 Duden, Thomas . . . Moss Kennels, Haydon Bridge

† Du Buat, Count. Chateau de la Sunardiére, France  
 † Ducie, Earl of . . . Tortworth, Wootton-under-Edge  
 Duckering, R. E. . . . Northorpe, Kirton Lindsey  
 Duckham, T. . . . Baysham Court, Ross, Herefordshire  
 † Duckworth, Sir J., Bart. . . . Wear House, Exeter  
 † Duckworth, Russell . . . Murtrey Hill, Frome  
 Dudding, Henry . . . Pantown House, Wragby  
 Dudding, Thomas . . . Pockerby, Goole  
 Dudding, William . . . Lambcroft, Louth, Lincolnshire  
 Dudgeon, J. . . . 8, Tavistock Square, W.C.  
 Dudfield, Benjamin . . . Kinlet, Bewdley, Salop.  
 Duffield, James . . . Great Baddow, Chelmsford  
 Dufty, Thomas . . . Knapthorpe, Newark  
 Dumbrell, James . . . Ditchling, Sussex  
 † Duncan, Alexander . . . Knossington Grange, Oakham  
 † Duncan, James . . . Benmore, N.B.  
 Duncan, W. G. . . . Bradwell House, Stony Stratford  
 † Duncombe, Hon. O., M.P. . . . Waresley, Biggleswade  
 Duncombe, Hon. Adl. . . . Killerwick Percy, Pocklington  
 † Duncombe, Sir P. P., Bart. . . . Bletchley, Bucks.  
 † Dun, Finlay . . . Weston Park, Shipston-on-Stour  
 Dunlop, A. M. I. . . . Westm. Chambers, Victoria St, S.W.  
 Dunn, John . . . Fernhill Villa, Market Drayton  
 Dunn, Jonathan . . . Kelfield Lodge, York  
 Dunn, Nicholas J. . . . Elm Grove, St. Florence, Tenby  
 † Dunn, Thomas . . . 1, York Gate, Regent's Pk., N.W.  
 † Dunn, Wm. H. . . . Inglewood, Hungerford  
 † Dunne, Thomas . . . Bircher, Leominster  
 † Du Plessis, Gustave . . . Chateau du Plassi, France  
 Duplessis, Jules . . . Newtown Park, Lynton  
 Dupuis, Rev. G. J. . . . Eton College, Windsor  
 Durant, Richard . . . Sharpnam, Totnes  
 Durlham, Makin . . . Thorne, Yorkshire  
 Dutton, John . . . Curbridge, Faringdon  
 † Duval, Fernand R. . . . 16, Place Vendôme, Paris  
 † Dyer, Major, H. C. S. . . . Westhorpe, Bromfield, Salop.  
 Dyke, Francis Hart . . . 3, Museum Street, York  
 Dyke, Sir P. H., Bart. . . . Lullington Castle, Dartford  
 Dyott, Col., M.P. . . . Freeford Manor, Lichfield

E.

Eagle, Alfred . . . Boxted, Bury St. Edmund's  
 Ealand, John Robert . . . Aisthorpe, Lincoln  
 Eardley, Wm. . . . Larkton Hall, Malpas  
 † Earle, Frederic W. . . . Edenhurst, Prescot, Lanc.  
 Early, Thomas . . . Witney, Oxon.  
 † Easterson, Thomas . . . Bawdsey, Woodbridge  
 Easton, George . . . Horsley Hill, South Shields  
 † Easton, James . . . Nest House, Gateshead  
 † Easton, James . . . Hothe Court, Bleas, Canterbury  
 Easton, William . . . 6, Hammet Street, Taunton  
 Easton, William . . . Bradford, Taunton  
 Eastwood, George . . . Healey Hall, Burnley  
 Eaton, Charles O. . . . Tolethorpe, Stamford  
 † Eaton, George . . . Spixworth, Norwich  
 Eccles, H. J. . . . Spriddlestone, Brixton, Plymouth  
 Eckersley, James . . . Burnt House, Chorley  
 Eckersley, Nathaniel . . . Standish Hall, Wigan  
 Eckley, Richard . . . 12, Darlington Place, Bath  
 † Eddison, Francis . . . 60, High West St., Dorchester

†Eddison, R. W. . . . . Headingly Hill, Leeds  
 †Eddison, William . . . . . Huddersfield  
 †Eddowes, Thos. Henry . . . . . Pontesbury, Salop.  
 †Eden, J. . . . . Beamish Pk., Chester-le-Street, Durham  
 Eden, Peter . . . . . Cross Lane, Salford  
 †Eden, Hon. Wm. Geo. . . . . Doncaster  
 †Edge, James Thomas . . . . . Strelley Hall, Nottingham  
 †Edmonds, F. E. . . . .  
 Edmonds, Giles . . . . . Eastleach, Lechlade  
 Edmonds, Wm. J. . . . . Southrop, Lechlade  
 Edmondson, T. G. . . . . Gresgarth Hall, Lancaster  
 Edmunds, Edmund . . . . . Rugby  
 Edwards, D. T. . . . . Taff Well, Cardiff  
 Edwards, Edward . . . . . Boreton, Shrewsbury  
 Edwards, Edwin . . . . . Brocton Grange, Shifnal  
 Edwards, G. Withers, jun. . . . . Woolston, Oswestry  
 Edwards, Sir H., Bt., M.P. . . . . Pye Nest, Halifax  
 Edwards, Henry N. . . . . Broadwood, Leominster  
 Edwards, James L. . . . . Rochester, Kent  
 Edwards, Joseph . . . . . Hutton, Weston-super-Mare  
 Edwards, Richard . . . . . Adlington, Shrewsbury  
 Edwards Richard . . . . . Trewern Hall, Welshpool  
 Edwards, T. F. . . . . Tanholt Farm, Eye, Peterborough  
 Eflingham, Earl of . . . . . Tusmore House, Bicester, Oxon.  
 Egerton, Lord . . . . . Tatton Park, Knutsford  
 Egerton, Sir P. de M. G., Bt. M.P. . . . . Tarporley  
 Eggar, James . . . . . Bentley, Farnham  
 Eggleston, Edward J. . . . . Great Peatling, Lutterworth  
 Eggleston, Wm. . . . . Wigston Magna, Leicester  
 Elcho, Lord, M.P. . . . . Armisfield, Haddington, N. B.  
 Eley, W. H., jun. . . . . Islingham, Frindsbury, Rochester  
 †Elkins, John Francis . . . . . Yelvertoft, Rugby  
 Ellett, Robert . . . . . Oakley Villa, Cirencester  
 Ellershaw, Charles . . . . . Bossall, York  
 †Elliot, John . . . . . Chapel Brampton, Northampton  
 Elliot, John . . . . . Moor Park Farm, Rickmansworth  
 †Elliot, J. Letsom . . . . . 10, Connaught Place, W.  
 Elliott, Samuel . . . . . Trafalgar House, Plymouth  
 Ellis, Charles . . . . . Preston House, Beddingham, Lewes  
 Ellis, James . . . . . Glenfield, Leicester  
 †Ellis, John . . . . . Artington, Guildford  
 Ellis, Philip P. . . . . Herbrandstone Hall, Milford Haven  
 †Ellis, Robert Ridge . . . . . Yalding, Kent  
 Ellis, Samuel H. . . . . Maldon, Essex  
 †Ellman, R. H. . . . . Landport, Lewes  
 Elston, William . . . . . Bank House, Selby  
 †Elston, Capt. W. . . . . St. Ann's Rd., North Brixton, S.  
 Elton, Sir E. M., Bt. . . . . Widworthy Court, Honiton  
 †Elwell, Charles John . . . . . Compton, Wolverhampton  
 †Elwell, E. . . . . Nenadfrith, Newtown, S. Wales  
 Elwell, Paul . . . . . Evelith Manor, Shifnal  
 Elwes, H. T. . . . . West Hoathley, East Grinstead  
 Elwes, Hugh W. H. . . . . Stowe Park, Bungay  
 Elwes, John H. . . . . Closeburn House, Cheltenham  
 Embleton, Robert . . . . . Backworth, Newcastle-on-Tyne  
 Emery, Richard A. . . . . Lostford, Market Drayton  
 Emery, R. Coleman . . . . . Hurston Place, Storrington  
 †Emson, H. H. . . . . Nether Hall, Cherry Hinton, Cambs.  
 England, Richard . . . . . Binham, Wells, Norfolk  
 Enniskillen, Earl of . . . . . Florence Court, Enniskillen  
 †Entwistle, John S. . . . . Foxholes, Rochdale  
 Enys, John Samuel . . . . . Enys, Penryn, Cornwall  
 Erichsen, H. G. . . . . 7, Gt. Winchester St Bldgs., E.C  
 †Erkoig, Adolphus . . . . . Derekegyhaza, Pesth, Hungary

Erle, Rt. Hon. Sir W., Kt. . . . . Bramshot Grange, Liphook  
 Ernest, Henry . . . . . 17, Salisbury Street, Strand  
 †Errington, Rowland . . . . . Sandon, Hexham  
 Esam, Wm. . . . . Avenham Park, Southwell  
 Esdaile, W. C. D. . . . . Burley Park, Ringwood, Hants  
 Etches, Edward . . . . . Derby  
 Ethelston, Rev. C. W. . . . . Up Lyme, Lyme Regis  
 Ettrick, Anthony . . . . . North Hylton, Sunderland  
 †Evans, E. Bickerton . . . . . Whitbourne Hall, Worcester  
 Evans, E. M. . . . . Llwynbarried, Nantmel, Kington  
 Evans, George . . . . . Wimborne, Dorset  
 †Evans, Henry J. . . . . Bank, Cardiff  
 Evans, H. . . . . Swanstone Court, Leominster  
 Evans, Isaac Pearson . . . . . Griff, Nuneaton  
 Evans, James Eaton . . . . . Haverfordwest  
 Evans, John . . . . . Uffington, Salop.  
 Evans, John . . . . . Hadnall Wood, Hadnall, Salop.  
 Evans, J. Jones . . . . . Cwmbychan Farm, Carmarthen  
 Evans, R. P. . . . . 4, Gray's Inn Square, W.C.  
 †Evans, R. W. . . . . Eytton Hall, Leominster  
 Evans, Samuel . . . . . Darly Abbey, Derby  
 Evans, Capt. T. B. . . . . Uddens, Wimborne, Dorset  
 Evans, Warren . . . . . Landowalls, Usk, Monmouthshire  
 †Evans, William . . . . . The Field, Newport, Mon.  
 †Evans, Rev. W. E. . . . . Burton Court, Herefordshire  
 †Evans, W. Herbert . . . . . Ford Abbey, Chard  
 Everard, W. . . . . Narboro' Wood House, Leicester  
 Eve, Frederick . . . . . Sherrington, Newport Pagnell  
 Everett, F. H. . . . . Bridgeham, Thetford  
 †Everett, W. S. . . . . Carlton Colville, Lowestoft  
 Everington, Wm, jun. . . . . Skegness, Burgh-le-marsh  
 †Everington, W. D. . . . . Dillington Hall., E. Dereham  
 Evershed, Henry . . . . . Shere, Guildford  
 Evershed, John . . . . . Hartfield, Tunbridge Wells  
 †Exeter, Marquis of . . . . . Burghley House, Stamford  
 Eyke, John . . . . . Stanton, Shifnal  
 †Eyre, Edwin . . . . . Preston Hall, Uppingham  
 †Eyre, G. E. . . . . Warrens, Stoney Cross, Southampton  
 Eyre, Henry R. . . . . Shaw House, Newbury  
 Eyre, R. T. . . . . Riverdale, Surbiton, S.W.  
 †Eyles, Capt. Harry . . . . . Knockwood Park, Tenterden  
 Eytton, John Wynne . . . . . Lees Wood, Mold  
 †Eytton, Thos. C. . . . . Vineyard, Wellington, Salop.

## F.

Faber, C. Wilson . . . . . Northaw House, Barnet, N.  
 Fair, Jacob W. . . . . Lytham, Preston, Lanc.  
 Fair, James . . . . . Tabley Villa Farm, Knutsford  
 Fair, Thomas . . . . . Westwood, Lytham, Lanc.  
 †Fair, William . . . . . Aston-by-Budworth, Northwich  
 Falmouth, Viscount . . . . . Mereworth Castle, Maidstone  
 †Fardon, H. F. . . . . 7, Braithwaite Rd., Birmingham  
 Fardon, J. A. . . . . Witton House, Droitwich  
 †Farhall, J. N. . . . . Tillington, Petworth  
 Farley, S. L. . . . . 4, Windsor Crescent, Newc-on-Tyne  
 Farmer, Edmund . . . . . Moreton in the Marsh  
 Farmer, James . . . . . Lawton, Pembridge  
 †Farmer, C. Haywood . . . . . Comberford Hall, Tamworth  
 Farnham, E. B. . . . . Quorndon House, Loughborough  
 Farnworth, J. K. . . . . Alderley Edge, Manchester  
 †Farr, Richard . . . . . Hereford

Farr, Wm. Wyndham . . . Iford, Christchurch, Hants  
 Farrell, E. W. . . . 3, Merrion Square East, Dublin  
 Farrell, John Arthur . . . Moynalty, County Meath  
 Farrer, Edmund . . . Sporre, Swaffham  
 Farrer, James . . . Ingleborough, Lancaster  
 Farrer, O. W. . . . Binnegar Hall, Wareham, Dorset  
 Farrer, H. R. . . . Green Hammerton, Yorkshire  
 Farthing, Walter . . . Stowey Court, Bridgewater  
 Farwell, Frederick G. . . . Wolverhampton  
 Faulconbridge, W. H. . . . Bestwood Pk., Bulwell, Notts.  
 Faulkner, John . . . Bretby Farm, Burton-on-Trent  
 Faulkner, William . . . Broxton, Chester  
 Faviell, George . . . Amcotes Lodge, Doncaster  
 Faviell, Mark, jun. . . .  
 Faviell, William F. . . . Down Place, Guildford  
 Fawcett, E. A. . . . Childwick Hall, St. Albans  
 Fawcett, James . . . Scaleby Castle, Carlisle  
 Fawcett, John . . . Durham  
 Fawcus, John . . . South Charlton, Chatham  
 Featherstonhaugh, R. . . . Rockview, Killucan, Ireland  
 Feilden, Major H. M., M.P. . . . Witton Park, Blackburn  
 Feilden Robert. . . . Coxbench, Derby  
 Fellowes, Jas. . . . 6, Bryanstone Square, W.  
 Fellowes, Robert. . . . Shotesham Park, Norwich  
 Fellowes, Rev. T. I. . . . Vicarage, Honingham  
 Fenn, Thomas . . . Stonebrook House, Ludlow  
 Fenton, Ferrar . . . Wakefield Road, Dewsbury  
 Fenton, Joseph . . . Bamford Hall, Rochdale  
 Fenton, Kirkby . . . Caldecote Hall, Nuneaton  
 Fenton, William . . . Beaumonds, Rochdale  
 Fenwick, George A. . . . The Bank, Newc.-on-Tyne  
 Fenwick, J. C. . . . Newcastle-on-Tyne  
 Ferard, Charles Colton . . . 50, Burton Crescent, W.C.  
 Ferris, T. . . . Manningford Bohune, Pewsey, Wilts.  
 Ferris, W. . . . Manor Ho., Milton, Pewsey, Wilts.  
 Feversham, Earl of. . . . Duncombe Park, Helmsley  
 Field, George . . . Ashurst Park, Kent  
 Field, Henry . . . East Lodge, Tulse Hill, S.W.  
 Field, James Pope . . . Hammond's End, Harpenden  
 Field, Samuel . . . Farnsfield, Southwell  
 Field, William . . . 224, Oxford Street, W.  
 Fielden, John . . . Dobroyd Castle, Todmorden  
 Fielden, J., M.P. . . . Stansfield Hall, Todmorden  
 Fielden, S. . . . Centre Vale, Todmorden  
 Fieldsend, C. R. . . . Kirmond, Market Rasen  
 Filgate, L. G. P. . . . Lisvenney, Ardee, Ireland  
 Filmer, Sir E., Bt. . . . East Sutton Park, Staplehurst  
 Finch, J. . . . 59, Mark Lane, E.C.  
 Finch, Rev. W. . . . Warboys, Huntingdonshire  
 Findlay, John . . .  
 Findlay, T. Dunlop . . . Easter Hill, Glasgow  
 Finlay, A. S. . . . Castle Toward, Greenock  
 Finney, Samuel . . . Gateshead  
 Finnis, Steriker . . . The Elms, Hougham, Dover  
 Firbank, Joseph . . . Newport, Monmouthshire  
 Firkins, Geo. John . . . Bishampton, Pershore  
 Firmstone, W. C. . . . Rockingham, Hagley, Stourbridge  
 Fisher, Capt. C. . . . Distington House, Whitehaven  
 Fisher, E. K. . . . Market Harborough  
 Fisher, Edward . . . Grove Hill, Beverley  
 Fisher, John . . . Carhead, Cross Hill, Leeds  
 Fison, A. J. . . . Barningham Hall, Ixworth  
 Fison, Cornell . . . Thetford  
 Fison, Cornell Henry . . . Thetford

†Fison, J. P. . . . Manor House, Feversham, Camba.  
 Fison, Joseph . . . Ipswich  
 Fitton, Samuel . . . Willastone, Nantwich  
 †Fitzgerald, Maj. H. T. G. . . . Maperton Ho., Wincanton  
 †Fitzhardinge, Lord . . . Berkeley Castle  
 Fitzherbert, Sir W., Bt. . . . Somersall Herbert, Uttoxeter  
 Fitz-Herbert, W. . . . Swynnerton, Stone  
 †Fitzhugh, Thomas Lloyd . . . Plas Power, Wrexham  
 Fitzhugh, Rev. Wm. . . . Street, Lewes  
 Fitzroy, George . . . Grafton-Regis, Stoney Stafford  
 Fitzroy, Lt.-Col. H. . . . Stratton Strawless, Norwich  
 †Fitzwilliam, Hon. C. W., M.P. . . . Alwalton, Peterboro'  
 Fitzwilliams, E. C. L. . . . Adpar, Newcastle Emllyn  
 †Fitzwygram, Lt.-Col. F. . . . Carlton Club, S.W.  
 Fletcher, Charles E. . . . Luscombe, Dawlish  
 †Fletcher, Maj.-Gen. E. C. . . . Kenward, Yalding  
 Fletcher, George . . . Shipton, Cheltenham  
 Fletcher, John . . . Merton Hall Farm, Merton, S.E.  
 Fletcher, John Charles . . . Dale Park, Arundel  
 †Fletcher, J. P. . . . Sunbury  
 †Fletcher, Capt. Joseph . . . Lowther St., Whitehaven  
 Fletcher, Thomas . . . Deeping St. Nicholas, Spalding  
 †Fletcher, W. H. . . . Shipton Olliffe, Cheltenham  
 Flower, Charles Henry . . . France Farm, Blandford  
 †Floyer, John, M.P. . . . Stafford, Dorchester  
 †Foljambe, F. J. Savile, M.P. . . . Osberton Ho., Worksop  
 Follows, F. W. . . . Cheetham, Manchester  
 Fookes, H. . . . Whitechurch Farm, Blandford  
 Forbes, John M. . . . Dropmore, Maidenhead  
 †Ford, Sir F. C., Bt. . . . Hartfield, Tunbridge Wells  
 †Ford, George . . . Barlaston, Stone, Staffordshire  
 Ford, J., jun. . . . Rushton Farm, Blandford  
 Ford, John . . . Tancred, Whixley, York  
 Ford, W. H. . . . Merridale Road, Wolverhampton  
 †Fordham, Edward King . . . Ashwell, Baldock  
 Fordham, John George . . . Royston  
 Forester, G. T. . . . Ercall Magna, Wellington, Salop  
 †Forrester, Jos. James . . .  
 Forster, A. T. . . . Garrettstown, Kinsale, Ireland  
 †Forster Charles, M.P. . . . Lysways Hall Rugeley  
 Forster, George . . . Washington, Durham  
 Forster, R. C. . . . White House, Gateshead  
 †Forster, Samuel . . . Southend, Sydenham, S.E.  
 Forsythe, James . . . Wolverhampton  
 Fortescue, Hon. G. . . . Boconnock, Lostwithiel  
 †Fortune, W. . . . The Drefor, Kerry, Montgomery  
 †Foster, H. Y. W. . . . Cranwell Lodge, Sleaford  
 Foster, J. . . . Ledham, Milford Junction  
 Foster, John . . . Copson Lodge, Hinckley  
 Foster, J. P. . . . Killhow, Wigton, Cumberland  
 †Foster, John James . . .  
 Foster, Matthew H. . . . Little Wymondeley, Steven  
 Foster, T. Nelson . . . Gloucester  
 Foster, Wm. . . . Canwick House, Lincoln  
 †Foster, W. O. . . . Apley Park, Bridgnorth  
 Fothergill, R. . . . Hensol Castle, Cowbridge, S. Wales  
 Fothergill, W. . . . Cefnrhychdir, Tredegar, Monmouth.  
 Foulkes, C. . . . St. Mary's Street, Whitechurch, Salop.  
 †Fountaine, Bernard T. . . . Stoke House, Blethley  
 Fowke, Sir F. T., Bart. . . . Lowesley Hall, Leicester  
 Fowler, Francis . . . Henlow, Biggleswade  
 Fowler, J. . . . Park Hill House, Ferry Hill, Durham  
 Fowler, John K., jun. . . . Aylesbury  
 Fowler, L. P. . . . Little Bushey Farm, Bushey

Fowler, R., jun....14, Bennett's Hill, Birmingham  
 Fowler, Richard...Broughton Farm, Aylesbury  
 Fowler, Robert...Leeds  
 †Fowler, Robert C....Gunton Hall, Lowestoft  
 Fowler, William...Acton Reynold, Shrewsbury  
 Fowler, William...Ryle House, Pauntley, Newent  
 †Fox, Chas. B....Malpas, Newport, Monmouthshire  
 Fox, Frederick F....Melbourne, Derby  
 †Fox, G. Lane...Bramham Park, Tadcaster  
 Fox, John...Coalbrookdale, Wellington, Salop.  
 Fox, William...Brook Farm, Dunston, Lincoln  
 †Fox, William...Adbury, Newbury  
 †Fox, William...Abbey, St. Bees, Cumberland  
 Frampton, Henry...Okers Wood, Dorchester  
 Francis, Clement...Quy Hall, Cambridgeshire  
 Francis, Frederick...Ramsden Hall, Billericay  
 †Frank, F. Bacon...Campall Hall, Doncaster  
 Frank, John Charles...Rhydairy, Oswestry  
 Frankish, William...Limber Magna, Ulceby  
 †Franklin, Joseph...Little Haseley, Tetsworth  
 †Franklin, Richard...Clemenstone, Bridgend  
 †Franklin, Thomas...Ascott, Wallingford  
 †Franklin, W. Taylor...Ascott, Wallingford  
 Franks, George...Thong, Gravesend  
 Franks, James...Bramley, Guildford  
 Franks, Thomas...21, Lower Fitzwilliam St., Dublin  
 Fraser, Henry N....Hayclose, Penrith  
 Frederick, Sir R., Bt...Burwood Park, Esher  
 †Freebody, Wm. Y....239, Hackney Road, N.E.  
 Freeman, Edward...Creething-All-Saints, Stonham  
 Freeman, Edwin...Chilton, Thame  
 †Freeman, Frederick...Speedwell Farm, Woburn  
 Freeman, John G....Aspall House, Debenham  
 Freeman, P....High Heaton, Newcastle-on-Tyne  
 Freeman, W. P. W....Pylewell, Lymington, Hauta.  
 Freer, Chas. T....The Coplow, Billesdon, Leicester  
 Freer, F. Hubert...Hampton, Evesham  
 Freer, Jesse...Rothley, Loughborough  
 †Fremlin, W. Arthur...Teston, Maidstone  
 French, Richard Day...St. John's, Bungay  
 †Frere, G. E....Roydon Hall, Diss  
 Fretwell, C. H. Be...Isle, York Rd., King's Cross, N.  
 Frewer, Alfred...Debenham, Ipswich  
 †Fries, Count August...Moravia, Praitz Station  
 †Frost, Chas...Wherstead, Ipswich  
 †Frost, Robert, Lime Grove, Chester  
 †Fry, James Thomas...Boston, Bromley, S.E.  
 Fry, Thomas...Baglake Farm, Dorchester, Dorset  
 †Fryer, H. C....Lodge Park, Taliesin, Shrewsbury  
 Fryer, W. Fleming...The Wergs, Wolverhampton  
 Fuggle, T. G....Crown Hotel, Worcester  
 Fulcher, Thomas...Elmham Hall, Thetford  
 Fuller, F. G....Reading  
 Fuller, Robert Willes...Croydon, S.E.  
 Fulljames, Thos....Foscombe, Gloucester  
 Furness, John...Coxhoe, Ferryhill, Durham  
 Furness, Captain M. W....Rugby  
 Fussell, Rev. James G. C....The Chantry, Frome  
 Fyers, Col. W. A., C.B....United Service Club S.W.  
 Fyson, Edward...Silverley, Ashley, Newmarket  
 †Fytche, J. Lewis...Thorpe Hall, Elkington, Louth

## G.

Gadesden, Augustus W....Ewell Castle, Surrey  
 Gadsby, A. A...George Yard, Bouverie Street, London  
 Gaitskell, J....Hall Santon, Carnforth, Lancashire  
 †Gayner, Charles, M.A...New College Lane, Oxford  
 Galpin, George...Tarrant Keynton, Blandford  
 Galpiu, John...Dorchester, Dorset  
 Galpin, Thomas P....Little Langford, Heytesbury  
 †Galton, Darwin...Claverdon Leys, Warwick  
 †Galway, Viscount, M.P....Serlby Hall, Bawtry  
 †Gamble, D....Gerard's Bridge, St. Helen's, Lane.  
 †Gamlen, Wm. H....Brampford Speke, Exeter  
 †Gammie, Geo...Shotover House, Wheatley, Oxon.  
 †Gandy, Capt. Henry...Eden Grove, Penrith  
 Gandy, Rev. J. H....Stanwick, Higham Ferrers  
 Gandy, Lt.-Col...Heaves, MINTHORPE  
 Garbutt, Thomas...Yarm, Cleveland  
 Garde, T....Ballinacurra, Middleton, co. Cork  
 Gardner, John...Twycross, Atherstone  
 Gardner, William...Bekebourne, Canterbury  
 Gardner, W. A....Hough Green, Chester  
 Gardom, J. W....Butterton Hall, Newcastle, Staffs.  
 †Gardom, T. W....The Yeld, Baslow, Chesterfield  
 †Garfit, Arthur...Sotherne, Lincoln  
 Garlit, Charles...Queenstown, co. Cork  
 †Garland, T. Bland...Hillfields, Reading  
 Garne, George...Churchill Heath, Chipping Norton  
 †Garne, John...Filkins, Lechlade  
 †Garne, Robert...Aldsworth, Northleach  
 Garne, Thomas...Broadmoor, Northleach  
 †Garne, Wm...Manor House, Cerney, Cirencester  
 Garnett, William...Clitheroe  
 Garuett, W. J....Bleasdale Tower, Garstang  
 Garrard, C. B. D....Lamar Court, St. Albans  
 †Garratt, John...Bishop's Hall, Exeter  
 Garratt, R. Lancefield...Thorpe Malsor, Kettering  
 †Garrett, Richard...Carleton Hall, Saxmundham  
 Garrold, R. H....Kilforge, Ross  
 Garsed, John...The Moorlands, Cowbridge  
 Garth, T. C....Haines Hill, Reading  
 Gartside, H....Wharmton Tower, Saddleworth, Yorks.  
 Gascoyne, William Whitehead...Sittingbourne  
 †Gaskell, Henry L....Kiddington Hall, Woodstock  
 Gaskell, Major W. P...Fulmer House, Slough  
 †Gatacre, Edward L...Gatacre Hall, Bridgnorth  
 Gater, John...West End, Southampton  
 †Gates, R....7, Sussex Place, Horsham  
 Gaudern, J....Earl's Barton, Wellingborough  
 Gaudin, Philip...Spring Farm, St. Heliers, Jersey  
 Gauntlett, W. H....Middlesboro'-on-Tees  
 †Gauthorp, H...Moorfield Ho., Widnes, Warrington  
 †Gawne, Edw. Moore...Kentraugh, Isle of Man  
 †Geary, Sir W. R. P., Bt...Oxen Heath, Tunbridge  
 Gedge, Charles J....Bury St. Edmund's  
 †Gee, John...Welford, Rugby  
 Gee, Thomas...Dowhurst Lodge, Wadhurst, Sussex  
 Gelsthorpe, Thomas...Morton Manor, Newark  
 †Genge, R. Waterston G., Puddleton, Dorchester  
 German, G....The Field, Measham, Atherstone  
 †Gerrard, William...Measham Lodge, Atherstone  
 Gerrard, John...Adlington, Chorley  
 Gervis, Sir G. E. M. T., Bt...Christchurch, Hants.

ibbens, Edward . . .Minster, Isle of Thanet  
 ibbins, H. . . .Bedhampton Manor, Havant, Hants.  
 ibbons, Henry . . .Hampton Bishop, Hereford  
 ibbon, H. J. . .Holmscales, Milnthorpe  
 ibbons, Thomas . . .Burn Foot, Longtown  
 Gibbs, George . . .Belmont, Bristol  
 Gibbs, H. H. . . .St. Dunstan's, Regent's Pk., N.W.  
 Gibbs, Philip H . . .Eckington, Worcester  
 Gibbs, Thomas . . .Sledmere, York  
 Gibbs, Thomas . . .26, Down Street, Piccadilly, W.  
 Gibbs, Wm. . . .Tyntesfield, Bourton, Bristol  
 Gibson, John Kirk . . .Ingleby, Lincoln  
 Gibson, Joseph . . .Whelprigg, Kirkby Lonsdale  
 Gibson, R. . . .South Benwell, Newcastle-on-Tyne  
 Gilbert, F. W. . . .Little Eastley, Bishopstoke  
 Gilbert, Henry . . .Barnby Manor, Newark, Notts.  
 Gilbert, John . . .Perry Barr, Birmingham  
 Gilbert, Joseph . . .Evesham  
 Gilbert, R. . . .Ashby Hall, Berghapton, Norfolk  
 Gilbert, R., jun. . . .Rockland St. Mary, Norwich  
 Gilbert, William A. . . .Cantley, Acle  
 Gilbertson, M. . . .Elm Cottage, Egham Hill, Surrey  
 Gilbey, Alfred . . .Wooburn House, Beaconsfield  
 Gilbey, Walter . . .Hargreaves Park, Stanstead  
 Giles, F. T. . . .Marsh House, Bentley, Farnham  
 Giles, Henry, jun. . . .Croxton Park, Thetford  
 Giles, John . . .Bradford House, Kidderminster  
 †Gilford, William . . .North Luffenham, Uppingham  
 Hill, George . . .Weston, Shrewsbury  
 Gillard, Henry . . .Stafford  
 †Gillart, R. . . .Llynloedd, Machynlleth  
 Gillett, C. . . .Lower Haddon, Hampton, Faringdon  
 Gillett, Frederick . . .Upton Downs, Burford  
 Gillett, John . . .Oaklands, Charlbury  
 Gillett, John . . .Minster Lovel, Witney  
 Gillott, Thomas L. . . .10, Broad Gate, Coventry  
 Gillow, Rev. Charles . . .Ushaw College, Durham  
 Gillow, Richard, jun. . . .Leighton Hall, Lancaster  
 Gilpin-Brown, G. . . .Sodbury Park, Richmond, Yorks.  
 Gilstrap, William . . .Fornham Pk., Bury St. Edmund's  
 Ginders, Samuel . . .Ingestre, Stafford  
 Glasier, William Richard . . .41, Charing Cross, S.W.  
 Gianville, R. Carew . . .Sconnors, St. Germans  
 Glegg, Lt.-Col. E. Holt . . .Backford Hall, Chester  
 Glen, G. . . .Stratton Audley Park, Bicester  
 †Glover, John . . .Bangley, Tamworth  
 Glover, Robert . . .Wexford, Lichfield  
 Glynn, Rev. Henry . . .Hawarden Rectory, Chester  
 Glynn, Sir S., Bt. . . .Hawarden Castle, Flints.  
 †Gobbitt, John . . .The Grove, Hollesley, Woodbridge  
 Goddard, H. N. . . .Manor Ho., Cliffe, Wootton-Basset  
 Godard, R. H. . . .Tibberton, Droitwich  
 Goddard, Thomas . . .St. Fagans, Cardiff  
 Goddard, Wm. Gilbert . . .Broad Chalk, Salisbury  
 †Goddard, Wm. R. . . .Glaston Hill Ho., Eversley, Hants  
 †Godsall, Philip Wm. . . .Iscoyd Pk., Whitchurch, Salop.  
 Godson, N. S. . . .Harewood House, Chipping Norton  
 Godwin, J. S. S. . . .West Peckham, Maidstone  
 Godwin, Robert . . .Water Eaton, Cricklade  
 Godwin, William . . .Lugwardine, Hereford  
 Goldingham, H. G. . . .  
 Goldsmith, Harry . . .Corn Hill, Bury St. Edmund's  
 †Golledge, Matthais . . .Forthampton, Tewkesbury

†Gonne, Charles . . .11, St. Helen's Place, E.C.  
 †Gooch, John Virel . . .Reform Club, Pall Mall, S.W.  
 Goodall, W. H. . . .Sutton, Market Drayton  
 Goodchild, Philip . . .The Grange, Glen Parva, Leicester  
 †Goodden, John . . .Over Compton, Sherborne, Dorset  
 †Goodhart, Charles E. . . .Langley, Beckenham  
 †Goodlake, F. Mills . . .Wadley House, Faringdon  
 Goodson, Wm. . . .Hill Farm, Mitcham, S.E.  
 Goodwin, Frederick . . .Britannia House, Worcester  
 Goodwin, J. . . .Bath and West of England Soc., Bath  
 Gordon, Charles . . .Wiscombe Park, Honiton  
 †Gorringe, Hugh . . .Southwick Green, Shoreham  
 †Gorst, William . . .Garston, Liverpool  
 Gosling, J. W. . . .Little Bradley Place, Newmarket  
 Gosling, Thomas G. . . .15, Portland Place, W.  
 †Gosset, Major Arthur . . .West Park, Mortlake, S.W.  
 †Gotel, Wm. Hepburn . . .Chilcombe Farm, Winchester  
 Gothorp, James . . .Mowbray Hill, Bedale  
 Gough, Ashwin D. . . .Hinton, Evesham  
 Gough, Ralph Dickinson . . .Willenhall, Staffs.  
 Gould, John . . .Hyde Hall, Denton, Manchester  
 Gouldburn, John . . .Broomhall, Nantwich  
 Gouldbourne, J. . . .Wilksley, Whitechurch, Salop.  
 Goulding, Wm. . . .108, Patrick Street, Cork  
 Goulter, Allen . . .Hawkesbury, Chipping Sodbury  
 Gouthwaite, Richard . . .Lumby, South Milford  
 †Gow, James . . .Fowler's Park, Hawkhurst, Kent  
 Gower, Andrew . . .Market Drayton  
 †Gower, Erasmus . . .Clyn Derwen, Narberth, S.Wales  
 †Gower, G. W. G. Leveson . . .Titsey Pk., Godstone  
 †Gower, J. Leveson . . .Bill Hill, Wokingham, Berks.  
 †Gower, Robt. F. . . .Clyn Derwen, Narberth, S.Wales  
 †Grafton, Duke of . . .Euston, Thetford  
 Graham, A. . . .Manor House, Barnston, Birkenhead  
 †Graham, James . . .  
 Graham, James . . .Parcelstown, Westlinton, Carlisle  
 Graham, Walter . . .West Drayton, Uxbridge  
 Graham, William, jun. . . .Pewet, Abingdon  
 Graham, William, jun. . . .Newport, Monmouth  
 Grain, Peter . . .Shelford, Cambridge  
 †Grandeau, Louis . . .Nancy, Meurthe, France  
 †Grant, Sir G. McPherson, Bt. . . .Ballindalloch, N.B.  
 †Grant, Colonel William L. . . .13, Victoria St., S.W.  
 †Grantham, George . . .Barcombe Place, Lewes  
 Grantham, Major, H. V. . . .West Keal Hall, Spilshy  
 Grantham, R. B., C.E., . . .22, Whitehall Place, S.W.  
 Grantley, Lord . . .Wonersh Park, Guildford  
 †Granville, Earl, K. G. . . .Aldenham, Bridgnorth  
 Graves, Robert . . .Charlton, Ludwell, Salisbury  
 †Gray, Frederick . . .Castle Carey, Somerset  
 †Gray, G. W. . . .Gatton, Reigate  
 †Gray, J. . . .Backwell Hill, West Town, Bristol  
 Gray, Thos. . . .Clayton St. West, Newcastle-on-Tyne  
 Grazebrook, George . . .The Race Course, Stourbridge  
 Greatorex, F. . . .Queen's Brewery, Manchester  
 Greaves, John . . .Elsfield, Oxford  
 Greaves, William . . .Bakewell, Derbyshire  
 Green, Alfred . . .Kinwarton, Redditch  
 Green, John . . .Heath Grange, Worcester  
 †Green, Joseph B. . . .Marlow, Leintwardine  
 Green, Robert . . .Scalby, Scarborough  
 Green, Stephen . . .Haverfordwest  
 Green, Rev. Thomas . . .Badby, Daventry

†Greenall, G. . . . .Walton Hall, Warrington, Lancashire  
 Greenaway, George C. . . . .Buswood Cott. Leamington  
 Greene, Edward, M.P. . . . .Westgate, Bury St. Edmd's.  
 †Greene, Harry A. . . . .Crown Street, St. Ives, Hunts.  
 Greene, John . . . . .Millbrook, Magany, Kildare  
 Greene, John M. . . . .Stradishall, Newmarket  
 †Greene, Thomas . . . . .Whittington Hall, Lancaster  
 Greene, Wm. . . . .Ditcham Park, Petersfield  
 Greening, E. O. . . . .35, King Street, Westminster, S.W.  
 Greenly, C. W. . . . .Tittley Court, Tittley, Herefordshire  
 †Greenfield, George . . . . .Belle Eau Park, Ollerton  
 Greenslade, John . . . . .Balham, Tiverton  
 †Greenwell, Thomas . . . . .Broomshields, Darlington  
 †Greenwood, J. . . . .Swarcliffe Hall, Ripley, Yorkshire  
 †Greetham, J. . . . .Stainfield Hall, Wragby, Lincoln  
 Greetham, William . . . . .Stainfield Hall, Wragby, Linc.  
 †Gregg, Thomas . . . . .  
 †Gregson, Matthew . . . . .Toxteth Park, Liverpool  
 †Greig, D. . . . .Fowler's Steam Plough Works, Leeds  
 Grenfell, Arthur Riversdale . . . . .Travellers' Club, S.W.  
 †Grenville, R. N., M.P. . . . .Butleigh Ct., Glastonbury  
 Greville, Lord . . . . .North Mimms Park, Hatfield  
 †Grey, Charles G. . . . .Dilston, Corbridge-on-Tyne  
 †Grey, Hon. G. De. . . . .11, South Audley Street, W.  
 †Grey, Hon. & Rev. F. De. . . . .Copdock, Ipswich  
 †Grey, Hon. Sir F. W., G.C.B. . . . .Lynwood, Staines  
 †Grey, Rt. Hon. Sir G., Bt., M.P. . . . .Fallowdon, Alnwick  
 Grey, Jas. . . . .Kimmerston, Wooler, Northumberland  
 Griffin, Alfred E. . . . .Wolverhampton  
 Griffin, Clement W. . . . .Werrington, Peterborough  
 Griffin, Edward . . . . .Towersey Manor, Thame  
 Griffin, George . . . . .Tortan, Kidderminster  
 Griffin, George F. . . . .Tillington, Stafford  
 Griffin, John . . . . .Borough Fen, Peterborough  
 Griffin, T. John . . . . .Preston Vale, Penkridge, Staffs.  
 Griffith, C. Darby . . . . .Padworth House, Reading  
 Griffith, E. H. . . . .Plas-Newydd, Trefnant, Rhyl  
 Griffith, J. . . . .Llwynduris, Newcastle-Emlyn  
 Griffith, John, jun. . . . .Trevorgan, Cardigan  
 Griffith, William . . . . .Glyn, Dolgelly  
 Griffiths, Thomas J. . . . .Bishop's Castle, Salop.  
 Griffiths, Edward . . . . .New Court, Hereford  
 Griffiths, John . . . . .Houlston Middle, Salop.  
 Griffiths, John Harward . . . . .The Weir, Hereford  
 Griffiths, John R. . . . .Brynderwen, Llanrwst  
 Griffiths, R. C. . . . .Park Farm, Broughton, Chester  
 Griffiths, Samuel . . . . .Overton, Flints.  
 Griggs, George . . . . .Oaklands, Romford  
 †Grimes, Wm. Howlett . . . . .Bubbenhall, Kenilworth  
 Grimston, Lt.-Col. Oswald A. . . . .  
 Grimwade, Edward . . . . .Ipswich  
 Grindley, William . . . . .Weeping Cross, Stafford  
 †Grisewood, H. . . . .Daylesford Ho., Chipping Norton  
 †Grissell, Thos. . . . .Norbury Park, Dorking  
 Groom, James . . . . .Arlstone House, Wellington, Salop.  
 Groucock, Charles . . . . .Stanfield Hall, Wymondham  
 Groves, Robert A. C. . . . .Berrington, Shrewsbury  
 Grout, John . . . . .Bull Hotel, Woodbridge  
 Grundy, E. S. . . . .Reddish Hall, Warrington  
 Gruning, Louis . . . . .Broomborough, Chester  
 Guilding, Richard . . . . .Brick Barns, Malvern Wells  
 Gulliver, William . . . . .Swalcliffe, Banbury  
 Gulston, Alan J., Drileton, Llangadock, Carmarthen

Gunnell, Thomas . . . . .Milton, Cambridge  
 Gunson, J. . . . .Ponsonby, Calder Bridge, Whitehaven  
 Gunson, John . . . . .Hopesfield, Lowick, Ulverston  
 †Gunter, Captain Robert . . . . .Wetherby  
 †Gurdon, B. . . . .Letton Hall, Shipdham, Norfolk  
 †Gurdon, Rev. P. . . . .Cramworth, Shipdham, Norfolk  
 †Gurdon, William . . . . .Bantham, Manningtree  
 †Gurney, John Henry . . . . .Marldon, Totnes  
 †Gurney, Rt. Hon. Russell, M.P. . . . .8, Palace Grdn., W.  
 †Gurteen, Daniel . . . . .Haverhill, Suffolk  
 Gutleridge, Charles . . . . .Assendon, Henley-on-Thames  
 †Guy, John Henry . . . . .Whitchurch, Aylesbury  
 †Guthrie, John . . . . .Guthrie Castle, Forfarshire  
 Guy, G. F. . . . .Angel Hill, Bury St. Edmund's  
 Gwyn, H. . . . .Dyffryn, Neath, Glamorganshire

## H.

Hack, Algernon . . . . .Buckminster, Grantham  
 Hack, Matthew . . . . .Leicester  
 Hadden, A. . . . .The Old Parks, Ashby-de-la-Zouch  
 Hagen, Jacob . . . . .Ropley House, Alresford  
 Haggard, Wm. M. R. . . . .Bradenham Hall, Thetford  
 Haig, George Augustus, . . . . .7, Argyle St., Regent St. W.  
 †Haig, J. H. . . . .  
 Haime, George . . . . .Over Farm, Gloucester  
 Haines, J. Poole . . . . .Hotelier House, Cheltenham  
 Hale, Bernard . . . . .Holly Hill, Hartfield, Sussex  
 Hale, Chas. C. . . . .Glenlochay, Killrie, Perthshire  
 Hales, C. . . . .Bassingbourne, Royston  
 Hales, Edward . . . . .The Waldrons, Croydon  
 Halford, T. . . . .Newbold-on-Stour, Shipston-on-Stour  
 †Halifax, Viscount . . . . .Hickleton Hall, Doncaster  
 Hall, Alexander Hall . . . . .Watergate, Emsworth  
 Hall, Capt. A. W. . . . .Claremont, Millbrook, Hants.  
 Hall, Benjamin . . . . .Wood Farm, Malvern Wells  
 Hall, Charles . . . . .Brickwood Villa, Croydon, S.  
 Hall, Collinson . . . . .Navestock, Romford, E.  
 Hall, Francis . . . . .Park Hall, Mansfield  
 Hall, George . . . . .Garford, Yarkhill, Ledbury  
 Hall, George S. . . . .Ely, Cambs.  
 †Hall, Henry . . . . .  
 Hall, James . . . . .Scarborough Hall, Beverley  
 Hall, J. O. . . . .1, Brunswick Row, Queen Sq., W.C.  
 Hall, Major-Gen. . . . .Carlton Club, Pall Mall, S.W.  
 †Hall, Marriott . . . . .Thorpe Salvin, Worsop  
 †Hall, Marshall . . . . .New University Club, S.W.  
 Hall, Richard . . . . .Baglan House, Neath, S. Wales  
 Hall, Richard . . . . .Great Barford, Deddington  
 †Hall, William . . . . .Ashton, Leominster  
 Hall, Wm. . . . .Seven Springs, Cubberley, Cheltenham  
 Hall, William Henry . . . . .Glen Parva, Leicester  
 Hallam, Thos. . . . .Bridlesmith Gate, Nottingham  
 †Hall Dare, F.M. . . . .  
 Hall Dare, R. W. . . . .Newtownbarry-house, Ireland  
 Hallett, F. F. . . . .The Manor House, Brighton  
 †Halliday, J. . . . .Chapel Cleeve, Taunton  
 Halls, Joseph . . . . .Deuham Castle, Bury St. Edmund's  
 Halsey, Thomas . . . . .The Hyde, Cheltenham  
 Hambleton, A. P. . . . .Harley Thorn, Newcastle, Staffs.  
 †Hambro, Charles, M.P. . . . .Milton Abbey, Blandford  
 †Hambrough, Albert J. . . . .Steep Hill Castle, Ventnor

Hamer, Charles M. . . Snitterfield, Stratford-on-Avon  
 Hamel, Alfred J. . . . Lancaster Place, Leicester  
 †Hames, John . . . Rotherby, Leicester  
 †Hamilton, Capt. Archibald . . . Rozelle, Ayr  
 Hamilton, Chas. W. . . . Hamwood, Clonee, Co. Meath  
 †Hamilton, John . . . Sundrum, Ayr, N. B.  
 †Hamilton, John . . . Hilston Park, Monmouth [Avon  
 †Hamilton, Sir R. N. C., Bt., K.C.B. . . . Stratford-on-  
 †Hamilton, Wm. M. . . . 2, Orchard Place, Canterbury  
 Hammersley, Hugh . . . Great Haseley, Tetsworth  
 †Hammersley, Wm. . . . Parkinson Street, Nottingham  
 †Hammerton, George . . . Princethorpe, Rugby  
 Hammond, John . . . Bale, Thetford  
 Hamond, Charles Frederick . . . Newcastle-on-Tyne  
 †Hamond, Nicholas . . .  
 †Hamond, W. Parker . . . Pampisford Hall, Cambridge  
 †Hampson, J. . . . Ullen Wood, Leckhampton  
 Hampton, George . . . Finedon Park Farm, Worthing  
 †Hanbury, E. . . . Eastrop Grange, Highworth  
 Hanbury, Osgood, Jun. . . . Howe Hatch, Brentwood  
 Hanbury, Robert . . . Poles, Ware  
 Hancock, J. Donne . . . Halse, Taunton  
 Hancox, Edward O. . . . Evesham  
 Hand, James . . . Ludlow  
 †Handley, Maj. B. . . . Pointon House, Folkingham  
 Handy, Edward . . . Sierford, Cheltenham  
 Hankey, George A. . . . Ferney Hill Farm, Barnet  
 Hamner, Sir J. Bt., M. P. Bettisfield, Pk., Whitechurch  
 Hannam, Henry J. . . . Burcote, Abingdon  
 †Hannay, Robert . . . Springfield, Ulverston  
 Hanning, James . . . Little Oat Hall, Burgess Hill  
 Harbin, George . . . Newton House, Yeovil  
 Harbord, Collet . . . Bookers Lee, Cranleigh, Guildford  
 †Harcourt, E. W. . . . Stanton Harcourt, Witney  
 Harcourt, Colonel F. V. . . . 5, Carlton Gardens, S.W.  
 †Hardacre, Richard . . . Hellifield, Leeds  
 Harding, Egerton W. . . . Old Springs, Market Drayton  
 Harding, Charles . . . Knighton, Leicester  
 †Harding, John . . . Dursley, Gloucestershire  
 Harding, James . . . Waterson, Dorchester  
 Harding, John . . . Bicton House, Shrewsbury  
 Harding, T. K. . . . Maiden Bradley, Bath  
 Harding, W. . . . East Woodyates, Cranborne, Salisbury  
 Hardinge, E. S. . . . Stonewall Park, Edenbridge  
 Hardon, Edwin . . . Heaton Norris, Stockport  
 Hardwick, Alfred . . . Hangleton, Portslade  
 Hardwick, R. . . . Bowden, Altrincham, Cheshire  
 Hardy, A. . . . Mackley House, Sudbury, Derbyshire  
 Hardy, B. . . . Greenhouse Farm, Ashover, Chesterfield  
 Hardy, James . . . Jaques Hall, Manningtree  
 †Hardy, John, M.P. . . . Dunstall Hall, Burton-on-Trent  
 Hardy, J. . . . Baguley House Farm, Northinden  
 Hardy, Peter . . . The Grange, Claines, Worcester  
 Hardy, Richard . . . Marchington, Uttoxeter  
 †Hardy, W. H. C. . . . Letheringsett Hall, Holt, Norfolk  
 †Hare, Sir J., Bart. . . .  
 Hare, Sir Thos., Bt. . . . Stow Hall, Downham Market  
 Hare, T. J. . . . Croke Hall, Chorley  
 Hare, Thos. W. . . . Berthddu, Llandinam, Montgomery  
 †Harewood, Earl of . . . Harewood House, Leeds  
 †Harford, J. B. . . . Stoke House, Stoke Bishop, Bristol  
 †Harford, W. . . . Barley Wood, Wrington, Bristol  
 Hargreaves, Edward H. . . . Kirkham, Lancashire

Harker, James . . . iTbself, Alfreton  
 Harkes, David . . . Mere, Knutsford, Cheshire  
 †Harland, Henry Seaton . . . Brompton, York  
 †Harle, J. J. . . . Mill Hills, Haydon Bridge  
 Harlock, Henry . . . Farnham, Bury St. Edmund's.  
 †Harman, Hon. L. King . . . Ballymena, Co. Longford  
 †Harper, Latimer . . . Chilton Cottage, Hungerford  
 Harper, William . . . Bury, Lancashire  
 Harrett, R. . . . Kirkwhelpington, Newcastle-on-Tyne  
 Harries, Francis, jun. . . . Cruckton Hall, Shrewsbury  
 Harris, Charles T. . . . K. Knighton House, Leicester  
 Harris, Edward . . . Horbling Vicarage, Folkingham  
 Harris George Shirley . . . Leicester  
 Harris, John . . . Nottingham  
 Harris, John Dove, Jun. . . . K. Knighton, Leicester  
 †Harris, Lord . . . Belmont, Faversham  
 Harris, Samuel . . . Westcoates Grange, Leicester  
 Harris, Thomas . . . Moston, Stanton, Salop.  
 Harris, Thomas . . . Stonylane, Bromsgrove  
 Harrison, Col. Broadley . . . Kynastone, Ross  
 †Harrison, Daniel . . . Kendal  
 Harrison, John . . . Summerlands, Kendal  
 †Harrison, John . . . The Willows, Leicester  
 Harrison, John . . . Warmingham, Sandbach  
 Harrison, J., jun. . . . Snelston Hall, Ashbourne  
 Harrison, J. T. . . . 3, Park Place Villas, Maida Hill  
 Harrison, Rev. J. H. . . . Bugbrooke Rectory, Weedon  
 †Harrison, Richard . . . Wolverton, Stony Stratford  
 Harrison, Rev. R. J. . . . Caerhowell, Garthmyl, Salop  
 Harrison, T. Ashton . . . Stalybridge, Cheshire  
 Harrison, W. H. . . . Oxenden, Northamptonshire  
 †Harrison, William . . . Samlesbury Hall, Preston  
 Harrold, G. A. . . . Leicester  
 Harrowby, Earl of, K.G. . . . Norton Ho., Campden  
 Hart, Henry P. . . . Beddingham, Lewes  
 Hart, John . . . Strangeways, Manchester  
 †Harter, Rev. G. G. . . . Cranfield, Newport Pagnell  
 †Harter, Jas. Collier . . . Broughton Hall, Manchester  
 Hartill, Jeremiah . . . Willenhall, Wolverhampton  
 Hartland, W. Jun. . . . Bodley, Westbury-on-Severn  
 Hartley, Gilford Wm. . . . Rose Hill, Whitehaven  
 Hartopp, Sir J. Bt. . . . Four Oaks Hall, Sutton Coldfield  
 Harvey, Chas. W. . . . Walton-on-the-Hill, Liverpool  
 Harvey, George . . . Belton, Great Yarmouth  
 Harvey, John J. . . . Stenboro' House, Sandwich  
 †Harvey, Richard . . . Greenaway, Torquay  
 Harvey, Richard H. . . . Slade House, Haverfordwest  
 Harvey, William . . . Timworth, Bury St. Edmund's  
 Harward, John . . . Chaddeley Corbet, Kidderminster  
 Harwood, Thomas . . . Bestead Hall, Ipswich  
 †Haslam, John Perceval . . . Gilmow House, Bolton  
 †Haslewood, L. R. . . . 194, Gresham Ho., Old Broad St.  
 †Hassall, Geo. . . . Shelford Manor, Racliffe-on-Trent  
 Hassall, Joseph . . . Great Wigston, Leicester  
 Hassall, Wm. . . . Bubney, Whitechurch, Salop.  
 Hatfield, Chas. Taddy . . . Hartsdown House, Margate  
 Hatherton, Lord . . . Teddesley, Penkridge  
 Hathorn, A. . . . Smeathalls, Ferrybridge, Yorkshire  
 Hathornthwaite, W. H. . . . Wyersdale, Dolphinholme  
 Hatton, William . . . Kingston, Tetsworth, Oxon.  
 Haves, William . . . Bacon's Farm, Mountnessing  
 Haward, R. . . . Mells Hill, Halesworth  
 Hawarden, Viscount . . . Dundrum Castle, Cashel

- Hawdon, W. . . . Walkerfield, Staindrop, Durham  
 †Hawkesworth, R. S. . . Forest Mountrath, Ireland  
 Hawken, Thomas. . . Mellingley, St. Issey, Cornwall  
 Hawkes, Thomas. . . Foxdown, Wellington, Somerset.  
 †Hawkes, William. . . Thenford, Banbury  
 Hawkins, Rev. Canon. . . St. Woolas, Newport, Mon.  
 †Hawkins, T. . . Bentley Hall, Ipswich  
 †Hawkins, Thos., jun. . . Mannington Ho., Hereford  
 Hawthorn, W. . . Benwell Cottage, Newcastle-on-Tyne  
 †Hay, C. Anderson. . York Ter., Regent's Pk., N.W.  
 Hayes, Henry. . . Stamford  
 Hayes, John Higson. . . Frodsham  
 †Hayne, John. . . 24, Gloucester Sq., Hyde Park, W.  
 Hayter, Tom John. . . West Woodgates, Salisbury  
 Hayward, Frederick. . . Needham Market  
 Haywood, Edward W. . . Sillins, Redditch  
 Haywood, George. . . Derby  
 Haywood, Henry. . . Blakemere House, Hereford  
 Haywood, James, jun. . . Derby  
 Hazlerigg, Sir A. Grey, Bt. . . Noseley Hall, Leicester  
 Head, John. . . Orwell Works, Ipswich  
 Headlam, M. . . Whorlton, Darlington [nard Castle  
 †Headlam, Rt. Hn. T. E., M.P. . Gilmonby Hall, Bar-  
 Headly, Edward. . . 2, New Square, Cambridge  
 †Heale, H. Newton. . . Highfield, Hemel Hempstead  
 Healey, Edward C. . . Wypthurst, Guildford  
 Heald, Wm. . . St. Margaret's, Ware  
 Heasman, Alfred. . . Angmering, Arundel  
 Heath, John. . . Cleobury Mortimer, Bewdley  
 †Heathcote, Capt. E. . . . Blanshard, Lyndhurst  
 †Heathcote, J. M. . . . Conington Castle, Stilton  
 Heatley, James H. . . Engleton Hall, Penkridge  
 Heatley, John. . . Eaton, Market Drayton  
 †Heatley, R. T. . . . Eaton Grange, Market Drayton  
 Heatley, T. . . Pattingham, Wolverhampton  
 Heaton, T. . . . Castle Hill, Alton, Cheadle, Staffs.  
 Hedley, Thomas. . . Cox Lodge, Newcastle-on-Tyne  
 †Hellyer, G. W. M. . . . Tan-y-Garth, Bettws-y-coed  
 Helyar, Wm. Hawker. . . Coker Hall, Yeovil  
 Hemming, Richard. . . Bentley Manor, Bromsgrove  
 †Hempson, John A. . . . Erwarton Hall, Ipswich  
 †Hemsley, John. . . Shelton, Newark, Notts.  
 Henderson, John. . . The Shrubbery, Sandwich  
 Henderson, John. . . Horsley Hill, South Shields  
 Henderson, W. . . . Fowberry Mains, Belford  
 †Heneage, Edward. . . Hainton Hall, Wragby  
 Heneage, Geo. H. Walker. . . Compton Basset, Calne  
 †Henley, Henry Cornish. . . Leigh House, Chard  
 Henley, Joseph J. . . Sherburn Lodge, Tetsworth  
 †Henley, Rt. Hon. J. W., M.P. . . . Watpury, Oxon.  
 Henniker, Capt. . . . Weston Hall, Bulkington, Rugby  
 Henniker, Lord. . . Woodlands, Ipswich  
 †Henning, James. . .  
 Henning, William L. . . . Frome House, Dorchester  
 Henry, Frederick H. . . . Lodge Park, Straffan, Ireland  
 Henry, Capt. James. . . Blackdown House, Petworth  
 Hensman, H. D. . . . Duston Lodge, Northampton  
 Henson, William. . . Burton Fields, Hinckley  
 Hepburn Thomas. . . Clapham Common, S.W.  
 Hepworth, Joshua. . . Rogerthorp, Pontefract  
 Herbert, E. . . . Llansantffraed, Abergavenny  
 †Herbert, John Maurice. . . Rocklands, Ross  
 †Herbert, Maj.-Gen. Hon. P. E., M.P. . Berkeley Sq.
- Herbert, Thos. . . 86, Welford Road, Leicester  
 Hercy, John. . . Cruchfield House, Maidenhead  
 Herrick, Wm. Perry. . . Beau Manor Park, Loughboro  
 †Herries, Lord. . . Everingham Park, Pocklington  
 Herring, Frank. . . Brestard Park Farm, Sevenoaks  
 Herring, Henry. . . Caldwell Farm, Kidderminster  
 Hersee, Miss. . . Westgate, Chichester [mund's  
 Hervey, Lord A., M.P. . . . Ickworth, Bury St. Ed.  
 †Heseltine, E. . . 6 A, Austin Friars, E.C.  
 Hesketh, Sir T. G., Bt., M.P. . Rufford Hall, Ormskirk  
 Heskett, William. . . Plumpton Hall, Penrith  
 Heslop, Rev. Gordon. . . Cossall, Nottingham  
 Heslop, Isaac. . . Urepeth, Chester-le-Street  
 Hesseltine, W. . . Beaumont Cote, Barton-on-Humber  
 †Hester, G. P. . . Town Clerk's Office, Oxford  
 Hetherington, J. R. . . Carleton, Carlisle  
 Hetherington, Robt. . . Manor Ho., Ropley, Alresford  
 Hetherington, R. Beaty. . . Park Head, Silloth  
 Hewer, Robert. . . Faigreen Farm, Clipping Norton  
 Hewertson, Nelson. . . Newport, Monmouthshire  
 Hewett, James. . . Posbrooke, Titchfield  
 Hewett, William Henry. . . Norton Court, Taunton  
 Hewson, John Dale, M.D. . . . Coton Hill, Stafford  
 Heygate, Captain E. N. . . . Buckland, Leominster  
 †Heytesbury, Lord. . . Heytesbury, Wilts  
 †Heywood, J. . . 26, Palace Gardens, Kensington, W.  
 Heywood, Wm. H. . . . Dunham Massey, Altrincham  
 †Hibbert, H. . . Broughton Grove, Grange, Lancashire  
 †Hibbert, John. . . Braywick Lodge, Maidenhead  
 †Hibbert, P. E. T. . . 14, Hill Street, W.  
 Hibbert, T. J. . . Broughton Grove, Newton-in-Cartmel  
 †Hibbert, Washington. . . 14, Hill Street, W.  
 Hibbit, A. W. . . . Penkridge, Staffordshire  
 Hicken, John. . . Dun Cow Hotel, Dunchurch, Rugby  
 †Hicks, Sir F., Bt. . . Oakfield, Streatham Hill, S.W.  
 Hicks, G. H. T. . . Hill Grove, Wells, Somerset  
 Hicks, L. H. . . Paddock Lodge, Kentish Town, N.W.  
 †Hicks, Thomas. . . Holmewood, Streatham Hill, S.W.  
 Hickson, Richard. . . Hougham, Grantham  
 Higginbotham, Samuel. . . Killermont, Glasgow  
 Higgins, Col. Wm. B. . . . Pict's Hill, Bedford  
 †Higginson, Edmund. . . Saltmarsh, Bromyard  
 Higgs, Albert A. . . The Bath Farm, Penkridge  
 †Higgs, J. Birch. . . Brewood, Penkridge  
 Highfield, George. . . Blencogo House, Wigton  
 Hilder, William. . . Tenterden  
 †Hildyard, J. R. W. . . Hutton-Honville, Northallerton  
 †Hildyard, Thomas, B. T., M.P. . . Flintham, Newark  
 Hill, Rev. Abraham. . . 24, Spa Place, Leicester  
 Hill, Henry. . . 52, Queen's Gate Terrace, S.W.  
 Hill, Rev. J. . . The Citadel, Hawkston, Shrewsbury  
 Hill, John. . . Llancasts, Usk  
 Hill, John. . . Wistaston Manor House, Nantwich  
 Hill, John. . . Severn Stoke, Worcester  
 Hill, Rev. R. P. . . Bromesberrow, Ledbury  
 Hill, Richard. . . Orleton Court, Ludlow  
 †Hill, T. Rowley. . . Catherine Hill House, Worcester  
 Hill-Trevor, Lord A. E., M.P. . . Brynkinalt, Chirk  
 Hilliam, Capt. Thomas. . . Willesby Hall, Spalding  
 Hilliard, Rev. J. A. S. . . Little Wittenham, Abingdon  
 Hilliard, William E. . . Cowley House, Uxbridge  
 Hills, Alfred. . . The Coppice, Penkridge  
 Hills, William Arthur. . . Hammerwich, Lichfield



Hilton, Henry... Sole St. Ho., Selling, Faversham  
 Hilton, Robert S... Milstead Rectory, Sittingbourne  
 Hilton, Stephen Musgrave... Brambling, Wingham  
 Hilton, Capt. Thos... Nackington Ho., Canterbury  
 †Hippisley, John... Stone Easton, Bath  
 †Hipwell, G. M... Elmore Lodge, Sutton, Surrey.  
 Hitchcock, Rev. J... Chitterne All Saints, Heytesbury  
 Hitchman, John, M.D... Mickleover, Derby  
 Hobbs, Charles... Maisey Hampton, Cricklade  
 Hobbs, William... Derward's Hall, Bocking, Essex  
 Hoblyn, W. P... The Fir Hill, St. Columb, Cornwall  
 Hobson, J... St. Neots, Hunts.  
 Hobson, John George... Curlew Lodge, Long Sutton  
 †Hobson, Thomas, Pownall Hall, Wilmslow  
 Hockenhuil, John... The Flax Yards, Tarporley  
 Hockin, John... Broomhill, Bude, Cornwall  
 Hodgkinson, Enoch... Morton Grange, Retford  
 †Hodgkinson, F... Kirkby, Sutton in Ashfield  
 †Hodgkinson, G... Kirkby in Ashfield, Nottingham  
 Hodgkinson, Grosvenor, M.P... Newark, Notts.  
 Hodgkinson, Richard... Osberton Grange, Worksop  
 †Hodgson, E. G... Charsfield Hall, Wickham Market  
 †Hodgson, Henry Tylston... Harpenden, St. Albans  
 Hodgson, Isaac Scott... Sodyll Hall, Rhuabon  
 †Hodgson, J. Stewart... Denbigh, Haslemere  
 Hodgson, R... Crofton Mills, Blyth, Northumberland  
 †Hodgson, William... Gilston Park, Herts  
 Hodgson, William... New Parks, Falsgrave, Scarboro.  
 Hodgson, W. N., M.P... Newby Grange, Carlisle  
 Hodsoll, J. H... Loose Court, Maidstone  
 †Hoffschlaeger, J. F... Weisin, bei Mecklenburg  
 Hogg, James... Buckton, Belford, Northumberland  
 Hogg, William... Mitford Steads, Morpeth  
 Hoggins, Thomas... Trafford Lodge, Chester  
 †Holbech, Rev. C. W... Farnborough, Banbury  
 Holben, R. Rowley... Barton, Cambridge  
 Holborow, Daniel B... Knockdown, Tetbury  
 †Holborow, D. C. Bagpact Ct., Wootton-under-Edge  
 Holder, W... Yemston Ct., Upper Sapey, Worcester  
 Holding, Henry... Fardington, Alton  
 Hole, James... Knowle, Dunster  
 Hole, James... Muskham Woodhouse, Newark  
 Holehouse, John... Gaer Hill, Chepstow  
 †Holland, Dr. Chas... St. Chad's, Lichfield  
 Holland, Francis D... Cropthorne Court, Pershore  
 Holland, J... Deeping St. Nicholas, Spalding  
 Holland, J. W... Deeping St. Nicholas, Spalding  
 Holland, Robert, Moberley, Knutsford  
 Holland, William... Broxton, Chester  
 Holland, William... Streethay, Lichfield  
 Holland, William... Pemberton, Wigan  
 Holliday, James... Lord Street, Liverpool  
 †Hollins, James C... Astley Bridge, Bolton  
 Hollis, Henry William... Keele, Newcastle, Staffs.  
 Hollis, Edward... Steam Mills, West Felton, Salop.  
 †Hollist, Hasler... Lodsforth, Petworth  
 Holloway, Horatio... Marchwood, Southampton  
 Holloway, Thos... Tittenhurst Lodge, Sunninghill  
 †Holloweg, M. de B... Runorva, Nakel, Prussia  
 †Holman, Stephen... Spring Lodge, Ealing  
 Holmden, James... Marlipit Hill, Edenbridge  
 Holme, John... Park Side, Milnthorpe  
 †Holmes, Gervas... Brockdish Hall, Scole  
 Holmes, Rev. John... Brooke Hall, Norwich

Holmes, John... Globe Lane, Norwich  
 Holmes, William... Cloverdale Island, Magee  
 Holtom, William Fifield... Cleeve Prior, Evesham  
 Homer, Thomas A... Tolpuddle, Dorchester, Dorset  
 Homfray, Lorenzo A... Woodlands, Newport, Mon.  
 Homfrey, S... Glenuske, Caerleon, Newport, Mon.  
 Hone, Henry... Stoke Orchard, Cheltenham  
 †Honey, Rev. P. F...  
 Honeywood, Mrs... Marks Hall, Kelvedon  
 Honeywood, William...  
 †Hood, Sir Alex. A., Bt... Bicknoller, Taunton  
 †Hood, Capt. Hon. A... Cumberland Lodge, Windsor  
 Hoole, Arthur... Hinnington House, Shifnal  
 Hooper, George... Cottoington Court, Deal  
 †Hooper, R. N... Llansanor Court, Cowbridge  
 †Hope A. Peterkin... Fenton Barns, Drem, N. B.  
 †Hope, Joseph... Whoof House, Carlisle  
 Hope, Samuel Pierce... Marchwiell Hall, Wrexham  
 Hope, Thomas Radford... Henfryn, Rhyll  
 Hope, William... Parsloes, Barking, Essex  
 Hope-Edwards, T. H... Netley, Shrewsbury  
 †Hopkins, Henry... Burnside, Van Dieman's Land  
 Hopkins, John... Tidmarsh House, Reading  
 Hopkins, Rev. T. H. T... Magdalen College, Oxford  
 Hopton, Rev. John... Canon-Frome Court, Ledbury  
 †Horley, Thomas, jun... The Fosse, Leamington  
 Hornby, Capt. Montague... Hanley, Shrewsbury  
 †Hornby, Rev. Robt... The Parsonage, Shrewsbury  
 Hornby, W. H., M.P... Shrewbridge Hall, Nantwich  
 Horncastle, Henry... Edwinstowe, Ollerton, Notts.  
 Horne, Thomas... Moreton-in-the-Marsh  
 †Horner, James B... Lincoln  
 Horner, John G... Martins Town, Dorchester  
 Horner, Rev. John... Mells Park, Frome, Somerset  
 Hornblow, William T... Ripple, Tewkesbury  
 Hornsby, Richard... Spittle Gate, Grantham  
 †Hornycold, J. V... Blackmore Park, Upton-on-Severn  
 Horsfall, T. Berry... Bellamour Hall, Rugeley  
 Horton, George... Harley, Much Wenlock, Salop.  
 †Horton, Samuel L... Park House, Shifnal, Salop.  
 Horton, Thomas... Harnage Grange, Shrewsbury  
 Horton, Capt. W., R.N... Livermere, Bury St. Edmd's.  
 †Horton, W. T... Skelmersdale, Hall, Ormskirk, Lanc.  
 Hosken, Samuel... Loggan Mill, Hayle  
 †Hoskins, Thos... Haselbury, Crewkerne, Somerset.  
 Hoskyns, Chandos Wren, M.P... Harewood, Ross  
 †Hoskyns, Rev. H. J... Blaby Rectory, Leicester  
 †Houblon, J. A... Hallingbury Pl., Bishop Stortford  
 †Houbton, Richard Archer... Bartlow, Cambridge  
 Houghton, J. S... Refreshment Rooms, Landport  
 Houghton, Thomas... Hemshill Manor, Nottingham  
 Houlder, Edwin... Fernwood, Sutton, Surrey  
 How, James... Broughton, Huntingdon  
 †Howard, Charles... Biddenham, Bedford  
 Howard, Hon. C. W. G... Naworth Castle, Brampton  
 Howard, C. J... Stockport, Cheshire  
 Howard, Edward J... Rise Farm, Nocton, Lincoln  
 †Howard, Henry... Greystoke Castle, Penrith  
 †Howard, Hon. James... Hazelby, Newbury  
 †Howard, James, M.P... Bedford  
 †Howard, Robert... Broughton Hall, Wrexham  
 Howard, R. G. F... Temple Bruer, Lincoln  
 Howard, Samuel... Dairy House Farm, Altrincham  
 Howard, Wm... Windsor Terrace, Taunton

Howden, Alexander... Murston Court, Pembridge  
 †Howell, Henry... Coates, Cirencester  
 Howells, John Lewis... Blackwood, Monmouth  
 Howland, A. R... Ludesden House, Thame  
 Howman, H.A... Halloughton, Coleshill, Warwickshire  
 †Hubback, Joseph... Liverpool  
 †Hubbard, Egerton... Aidington Manor, Winslow  
 †Hubbard, Wm. Egerton... St. Leonard's, Horsham  
 Hubbersty, H.A... Buxton  
 Hubbersty, W. Philip... Wirksworth, Derbyshire  
 Huddleston, Ferdinand... Sawston Hall, Cambridge  
 Hudson, Charles H... Sandall Grove, Doncaster  
 Hudson, John... Sibberscott, Lea Cross, Salop.  
 †Hudson, S... Wytbeford Hall, Shawbury, Salop.  
 Hudson, Thos... Longford Farm, Market Drayton  
 †Hudson, T. Moore... Castleacre, Brandon  
 Hudspith, W... Brooksidge, Haltwhistle, Northumb.  
 Huggup, James... West Sleekburn, Bedlington  
 †Hughes, Hugh... Brightling, Hawkhurst  
 †Hughes Hugh R... Kinmel Park, St. Asaph's  
 Hughes, Hugh Robert... Ystrad, Denbigh  
 Hughes, James... Wood Lawn, Oxford  
 Hulme, T. Dunwood Lodge, Endon, Stoke-on-Trent  
 †Hulme, W... The Bank, Pembroke, South Wales  
 †Hulse, Charles... Hall Grove, Bagshot  
 †Humberston, P. S... Glan-y-Wern, Denbigh  
 Humby, Joseph H... Ashley, Stockbridge, Hants.  
 †Hume, C. T... The Rectory, St. Leonard's, Sussex  
 Humphrey, Heber... Kingstone, Ashbury, Shrivensham  
 Humphrey, Arthur... Walpole St. Peter, Wisbeach  
 Humphrey, Henry... Ashington, Hurstpierpoint  
 †Humphreys, Henry... Woodhouse, Loughboro'  
 Humphreys, W. T... Calcott Hall, Oswestry  
 Humphries, E... Pershore  
 Humpidge, Thos... Burleigh, Cheshunt  
 Hunt, A. H... Birtley House, Chester-le-Street  
 †Hunt, G... Frenchwood, Preston, Lancashire  
 Hunt, George... Evesham  
 Hunt, Reuben... Earl's Colne, Essex  
 Hunt, Rowland... Kibsworth Hall, Leicestershire  
 Hunt, William... Deeping St. Nicholas, Spalding  
 Hunt, William... Leicester  
 Hunter, Lt.-Col. Charles... Mount Severn, Llanidloes  
 Hunter, Henry Launoy... Beech Hill, Reading  
 Hunter, John Joseph... Whickham Grange, Gateshead  
 †Hunter, Patrick... Roden, Wellington, Salop.  
 Hunter, Samuel T... Old Court, Abergavenny  
 †Hunter, L. R... Bedstow Ho., Aston-on-Clan, Salop.  
 Huntley, W. V... Welsh St. Donatts, Cowbridge  
 †Huntsman, Benjamin... West Retford, Notts.  
 †Hurdman, J. E... Mareham le Hill, Horncastle  
 Hurl, Joseph Cooke... Brislington, Bristol  
 Hurleston, W... Heathcote, Wasperton, Warwickshire  
 Hurrell, Henry... Harston, Cambridge  
 Hurrell, William... Newton, Cambridge  
 Hurst, Robert... Bank Buildings, Baillie St., Rochdale  
 Hurt, Albert F... Alderwasley, Belper  
 †Huskinson, Thos... Epperstone, Southwell  
 Hussey, Edward... Scotney Castle, Lamberhurst  
 †Hussey, R. Hussey... Taplow House, Maidenhead  
 Hutchinson, Col. Hon. H. K... Weston Ho., Towcester  
 †Hutchinson, James... Cowley Manor, Cheltenham  
 Hutchinson, John... Brougham Castle, Penrith

Hutchinson, Teasdale H... Manor House, Catterick  
 †Hutchison, Robert... Carlowrie, Kirkliston, N.B.  
 Hutley, Jonathan... Rivenhall Hall, Witham  
 Hutt, John... Water Eaton, Oxford [Gateshead  
 Hutt, Rt. Hon. Sir W., K.C.B., M.P... Gidside Hall,  
 Hutton, William... Gate Burton, Gainsborough  
 Huxtable, Ven. Archd... Sutton Waldron, Blandford  
 †Huyshe, Rev. J... Clysthydon Rectory, Collumpton  
 Hyett, John Edward... Haydon's Elm, Cheltenham  
 Hyett, W. H... Painswick, Gloucestershire  
 †Hylton, Lord... Heath House, Petersfield

## I.

Ikin, Edward... Moat House, Wem, Salop.  
 Iles, Daniel... Fairford Retreat, Fairford  
 Impey, William... Broomfield Hall, Chelmsford  
 Inge, Chas. Henry... Whittington Hurst, Lichfield  
 Inge, Rev. G... Thorpe Constantine, Tamworth  
 Ingham, William... Bishop Thornton, Ripley, Yorks.  
 Ingham, William... Armley, Leeds  
 Ingram, Hugo F. M... Hoarcross, Rugeley, Staffs.  
 †Ingram, George... Chetwynd Park, Newport, Salop.  
 †Ingram, John A... Wylie, Heytesbury  
 †Ingram, Joseph... The Elms, Sale, Manchester  
 Ingram, Thomas... Great Wigston, Leicester  
 Ingledew, William... Sceugh Farm, Penrith  
 †Innes, William... Field Place, Warnham, Horsham  
 Innocent, Arthur... Kibworth Beauchamp, Leicester  
 Insole, James Harvey... Ely Court, Llandaff  
 Irlam, William... Ridgefield, Manchester  
 †Ireland, William... Forthampton, Tewkesbury  
 Ironmonger, T... Victoria Street, Wolverhampton  
 Isham, A. C... Lower Winchendon, Aylesbury  
 Isham, Sir C. E., Bart... Lamport Hall, Northampton  
 Isham, Rev. R... Lamport Rectory, Northampton  
 Isherwood, Arthur B... Counden Hall, Coventry  
 Islip, Francis W... Burford Farm, Gt. Marlow, Bucks.  
 Ive, John G... Southend Lodge, Langley, Slough  
 Izon, John B... Walsgrave-on-Sowe, Coventry

## J.

Jackson, Daniel... Chadwell Place, Grays, Essex  
 Jackson, G... Higher Peover, Knutsford  
 Jackson, James... 6, Chapel Street, Preston  
 Jackson, P. R... Blackbrook, Gresmont, Hereford  
 Jackson, Thomas... Eltham Park, Kent  
 Jackson, T. Finch... Tattenhall Hall, Chester  
 †Jackson, William... Oak Bank, Carlisle  
 †Jacobsen, C. C... Whatfield, Ipswich  
 Jacson, Chas. Roger... Barton, Preston, Lancashire  
 James, Edward... Felton, Northumberland  
 James, Isaac... Tivoli, Cheltenham  
 James, James William... Mappowder, Blandford  
 James, John... Sandon Hall Farm, Stone, Staffs.  
 James, John... Lansoar, Caerleon, Mon.  
 James, John Prole... Cople, Bedford  
 James, Richard... High Street, Haverfordwest  
 James, T... Otterburn Castle, Newcastle-on-Tyne  
 James, Thomas... Shushions Manor, Church Eaton  
 James, Sir Walter C., Bt... Betteshanger, Sandwick

†James, Capt. Wm. E. . . . Barrack Lodge, Carlisle  
 †Jaques, Leonard. . . . Wentbridge House, Pontefract  
 Jaques, R. M. . . . Easby Abbey, Richmond, Yorks.  
 Jaques, T. G. . . . Blacktoft, Howden, Yorkshire  
 †Jay, John. . . . 46, West Seventeenth St., New York  
 Jefferson, Rev. J. Dunnington. . . Thicket Priory, York  
 †Jefferson, Robert. . . . Preston Hows, Whitehaven  
 Jefferson, Skelton. . . . Preston Hows, Whitehaven  
 Jefferys, G. E. . . . Rutland Works, Stamford  
 Jeffreys, N. N. . . . Hollybrook, Shirley, Southampton  
 †Jegon, Trew. . . . Slough  
 Jekyll, J. . . . Carholme Terrace, Newland, Lincoln  
 Jenmet, A. . . . Murrell Hill Farm, Binfield, Berks.  
 Jenkin, H. B. . . . Cotton Farm, Whitchurch, Salop.  
 †Jenkins, John B. . . . Kingstowne House, Abingdon  
 Jenkins, Richard David. . . . The Priory, Cardigan  
 Jenkinson, Francis. . . . Marston, Stafford  
 †Jenkinson, Sir G., Bt., M.P. . . . Eastwood, Berkeley  
 Jenkinson, Joshua. . . . Anfield, Cockermouth  
 Jenkinson, Wilson. . . . The Schoore Farm, Workington  
 Jenks, Thomas. . . . Orton, Trysul, Wolverhampton  
 Jenks, William. . . . Upper Penn, Wolverhampton  
 †Jenner, George. . . . Parsonage House, Udimore, Rye  
 Jennings, R. . . . Carmarthen  
 Jervis, Hon. E. Swinfen. . . . Aston Park, Staffs.  
 †Jervoise, F. E. J. . . . Herriard Park, Basingstoke  
 Jessop, Joseph. . . . Grove Farm, Chiswick, W.  
 Jeyes, Francis C. . . . Brixworth, Northamptonshire  
 Jillings, F. V. . . . Saxham, Bury St. Edmund's  
 Jillings, John. . . . Little Saxham, Bury St. Edmund's  
 †Jobez, Charles. . . . 17, Boulevard Madeleine, Paris  
 Jobson, William. . . . Buteland, Hexham  
 †Jocelyn-Pfoulkes, Major. . . . Eriviatt, Denbigh  
 †Jodrell, Sir Edw. R., Bt. . . . 64, Portland Place, W.  
 Johnson, A. H. . . . Gunnersbury House, Spring Grove, Isleworth  
 Johnson, A. H., jun. . . . Hanger Hill Farm, Ealing, W.  
 Johnson, B. B. . . . Withersfield, Newmarket  
 Johnson, Charles W. . . . 36, Mark Lane, E.C.  
 †Johnson, Cuthbert Wm. . . . Waidronhurst, Croydon  
 Johnson, Daniel J. . . . Kensal Green, Harrow Rd., W.  
 Johnson, Edward. . . . The Deanery, Chester-le-Street  
 Johnson, E. W. . . . Chichester  
 Johnson, Francis Dixon. . . . Aykleyheads, Durham  
 †Johnson, George. . . . Blaco Hill, Retford, Notts.  
 †Johnson, John George. . . . Cross House, Torrington  
 Johnson, Joseph. . . . High Street, Windsor  
 Johnson, Joseph. . . . Sutton by Beckingham, Newark  
 Johnson, Robert. . . . Kirkireton, Wirksworth  
 †Johnson, R. W. . . . Brickehampton Hall, Pershore  
 Johnson, Thomas. . . . The Hermitage, Frodsham  
 †Johnson, Thomas. . . . Whittlesea, Cambridgeshire  
 Johnson, T. C. . . . Chevet, Wakefield  
 Johnson, T. Fielding. . . . Stonegate, Leicester  
 Johnson, Walter F. . . . Leicester  
 Johnson, Wm. H. . . . Old Hall, Braunston, Leicester  
 †Johnston, A. R. . . . Heatherley, Wokingham  
 Johnston, J. Lindsay. . . . Crondall, Farnham, Surrey  
 Johnstone, Edward. . . . 3, King's Bench Walk, E.C.  
 †Johnstone, Rev. George. . . . Broughton, Hunts.  
 †Johnstone, J. C. H. . . . Hardwick Hall, Durham  
 Joicey, Edward. . . . Newcastle-on-Tyne  
 Joicey, John. . . . Newton Hall, Stocksfield-on-Tyne

Jollands, William D. . . . Buxshalls, Lindfield, Sussex  
 †Jonas, Arthur Owen. . . . Marwood Hill, Barnstaple  
 †Jonas, F. M. . . . Chrishall Grange, Saffron Walden  
 Jonas, George. . . . Duxford, Cambridge  
 †Jonas, George. . . . Ickleton, Saffron Walden  
 †Jonas, Henry. . . . 4, Whitehall, S.W.  
 Jonas, John Carter. . . . 3, St. Mary's Street, Cambridge  
 †Jonas, William. . . . Heydon, Royston  
 †Jones, Arthur Owen. . . . Marwood Hill, Barnstaple  
 †Jones, David. . . . Pantglas, Carmarthen  
 Jones, Edward. . . . Park Farm, Caersws  
 Jones, G. . . . Whitley Court, Upton St. Leonard's  
 Jones, George. . . . Starton, Kenilworth  
 Jones, George. . . . Stow, Downham Market  
 †Jones, H. P. . . . Portway House, Warminster  
 Jones, James. . . . The Oaklands, Spurston, Tarporley  
 Jones, James. . . . Norville, Bridgnorth, Salop.  
 †Jones, J. Bowen. . . . Eusdon House, Baschurch, Salop.  
 †Jones, James Cove. . . . Loxley, Warwick  
 †Jones, John. . . . Blaeno's, Llandovery, S. Wales  
 Jones, John. . . . Bryn Adda, Dolgelly  
 Jones, John. . . . Maesypanyd, Tal-y-llan, Merioneth  
 Jones, John. . . . The Lodge, Whitchurch, Salop.  
 Jones, John, Pantygoitre, Abergavenny  
 Jones, R. P. . . . The Hermitage, Whitchurch, Salop.  
 Jones, Stephen. . . . Lea Cross, Salop.  
 Jones, Thomas. . . . Kiln Green, Malpas  
 Jones, Thomas. . . . English Frankton, Ellesmere  
 †Jones, Wm. . . . Harrington, Shifnal  
 Jones, Rev. William. . . . Baschurch, Shrewsbury  
 †Jones, Sir W., Bt. . . . Cranmer Hall, Fakenham  
 †Jones, W. B. . . . Lissdare, Clonakilty, County Cork  
 Jones, W. H. . . . Canon Bridge, Madley, Hereford  
 Jordan, John S. . . . Elmswell, Driffield  
 Jordan, Wm. . . . Charlton Kings, Cheltenham  
 Josling Geo. F. . . . Great Thurlow Hall, Newmarket  
 Jowitt, Christopher. . . . Palterton, Chesterfield  
 Jowett, Rev. J. F. . . . Kingston Bagpuze, Abingdon  
 †Jowitt, Thomas. . . . The Old Weir, Hereford  
 Jukes, George. . . . Beslow Hall, Wroxeter, Salop.  
 Jukes, Mrs. Mary. . . . Cotwall, Wellington, Salop.  
 Jukes, Thomas. . . . Tern, Wellington, Salop.  
 †Justice, Henry. . . . Hinstock, Market Drayton

K.

†Karslake, Rev. W. H. . . . Mesham, Southmolton  
 †Kay, J. R. . . . Bass Lane House, Bury, Lancashire  
 Kay, R. . . . Forcett Valley, Darlington  
 †Kaye, John Edward. . . . Bretton Park, Wakefield  
 Kearne, J. H. . . . Mintare Birkdall Park, Southport  
 Kearsey, Charles. . . . Glewstone, Ross  
 Keary, H. W. . . . Aldenham, Bridgnorth, Salop.  
 Keeling, Chas. R. . . . Yew Tree Farm, Penkridge  
 Keeling, G. B. . . . Hampton House, Penkridge  
 †Keene, Rev. C. E. R. . . . Swincombe Ho., Nettlebed  
 Keep, Joseph S. . . . Russell Street, Birmingham  
 Keep, Richard. . . . Burghfield Place, Reading  
 Keightley, A. D. . . . Old Hall, Milnthorpe  
 Keir, Capt. G. L. . . . 33, Pembroke Rd., Kensington, W.  
 Kelham, Robert. . . . Bleasby Hall, Southwell  
 Kelsall, George. . . . Marton, Baschurch  
 †Kelsall, Henry, jun. . . .

Kelsall, Thos. . . Bettisfield Hall, Whitchurch, Salop.  
 †Kemble, Horatio. . . Potter's Bar, Barnet, Herts.  
 †Kemble, Thomas. . . Runwell Hall, Chelmsford  
 Kemp, Francis. . . Saddington, Market Harboro'  
 Kemp, J. . . . Hill's Road, Cambridge  
 Kempter, W. . . . New Crickett, Ellesmere, Salop.  
 Kendrick, Edward. . . Weeford, Lichfield  
 †Kennard, Adam S. . . . Dawpool, Birkenhead  
 †Kennaway, Sir John, Bart. . . . Escot, Honiton.  
 Kennedy, Myles. . . . Burton Cottage, Ulverston  
 Kennedy, Rt. Hon. T. F. . . . Dalquharran Castle, N.B.  
 Kenrick, George. . . . Thurgarton Hill, Southwell  
 †Kensington, E. T. . . . Beacon Downs, Exeter  
 Kent, George E. . . . North End, Portsea  
 †Kenyon, Hon. E. . . . Macefen, Whitchurch, Salop.  
 Kerfoot, John. . . . Faenol Bach, St. Asaph  
 Kerr, Hugh. . . . St. John's Place, Annan, N.B.  
 †Kerrich, John. . . . Geldeston Hall, Beccles  
 Kerry, T. R. . . . Lockford, Bury St. Edmund's  
 †Kesterton, Thomas. . . . Sutton, Surrey  
 Kett, George Samuel. . . . Brook House, Norwich  
 †Kettle, Geo. Mackenzie. . .  
 Key, Maj.-Gen. . . . Manor Ho., Coates, Cirencester  
 Key, Sir Kingsmill Grove, Bt. . . . Holborn Viaduct  
 †Keyworth, Henry Joseph. . . . Cottesford Pl., Lincoln  
 †Keyworth, J. R. Haldenby. . . . Greestone Ho., Lincoln  
 Kibble, Thomas. . . . Green Trees, Tunbridge  
 Kilpin, W. Wells. . . . Bickerings Park, Woburn  
 Kimber, Jas. Weaving. . . . Tubney Warren, Abingdon  
 †Kimberley, Earl of. . . . Kimberley, Wymondham  
 Kindersley, E. Leigh. . . . Syward Lodge, Dorchester  
 King, A. C. . . . Desning Hall, Bury St. Edmund's  
 King, C. . . . North Lodge Farm, Potter's Bar, Barnet  
 King, Chas. Allen. . . . Branksome Dene, Bournemouth  
 King, Frederick. . . .  
 King, George. . . . Saffron Walden  
 †King, George. . . . East Haddon, Northampton  
 †King, John G. . . . Beedon, Newbury  
 †King, John R. . . . North Ormsby, Louth  
 †King, John L. . . . Thorpe Abbots, Scole Inn, Norfolk  
 King, John Pittman. . . . North Stoke, Wallingford  
 King, Hon. J. P. L., M.P. . . . Woburn Pk., Chertsey  
 King, Raymond Fuller. . . . 39, Lombard Street, E.C.  
 King, Richard H. . . . Warkworth, Acklington  
 King, Richard King Meade. . . . Walford, Taunton  
 King, Robt. William. . . . Brinkley Hall, Newmarket  
 King, S. . . . Bockhampton Farm, Lambourne, Berks.  
 King, Thomas. . . . Preston, Bideston, Suffolk  
 King, Walter J. . . . Suffolk Chronicle Office, Ipswich  
 King, William. . . . Barton, Bury St. Edmund's  
 King, William. . . . Denham, Uxbridge  
 King, W. C. . . . Warfield Hall, Bracknell  
 King, W. D. . . . Woodcrofts, North End, Portsmouth  
 Kings, W. Padbury. . . . Lower Heyford, Banbury  
 Kingsbury, E. W. . . . 5, Effra Road, Brixton  
 Kingsbury, Thomas. . . . Boarscroft, Tring  
 †Kingscote, Col. R. N. F., M.P. . . . Kingscote, Glo's  
 †Kingsmill, Wm. H. . . . Sydmonon Court, Newbury  
 †Kingsnorth, Alfred. . . . Great Chart, Ashford, Kent  
 †Kingsnorth, Edward. . . . Brookland, New Romney  
 Kingston, Samuel, Spalding, Lincolnshire  
 Kinloch, Colonel. . . . Logie, Kirriemuir, N.B.  
 Kinnaird, Lord. . . . Rossie Priory, Inchture, Perthshire

Kirbell, Edward. . . . Lattimer, Chesham  
 Kirby, Thomas. . . . Crewe Hall Farm, Crewe  
 Kirk, Charles. . . . Sleaford, Lincolnshire  
 †Kirk, R. . . . Gale Bank, Leybourne, Wensleydale  
 Kirkaldie, Viscount. . . . Windsor  
 Kirkby, D. E. . . . Llanfendigaid, Towyn, Merioneth.  
 Kirkby, Thomas. . . . Cuxwold, Caistor  
 Kirkham, Thomas. . . . Biscathorpe House, Louth  
 Kirkland, Sir John, Bt. . . . 17, Whitehall Place, S.W.  
 Kirkpatrick, Capt. John. . . . Monk's Horton, Hythe  
 Kitson, James. . . . Leeds  
 Kitson, William. . . . Torquay  
 Knatchbull, Rev. W. . . . Cholderton Lodge, Amesbury  
 †Knatchbull, Wm. . . . Babington, Frome, Somerset.  
 †Knight, A. J. R. B. . . . Downton Castle, Leintwardine  
 Knight, Edward. . . . Chawton House, Alton  
 Knight, Edward. . . . Sandon, Stone, Staffs.  
 †Knight, E. . . . High Leaddon, Newent  
 Knight, Edward W. . . . Newton Harcourt, Leicester  
 Knight, Capt. Gregory. . . . Glen Parva Manor, Leicester  
 Knight, John. . . . Castle View House, Farnworth  
 Knight, John. . . . Forthampton, Tewkesbury  
 Knight, J. L. . . . Barton under Needwood, Staffs.  
 Knight, Maj. Joseph. . . . Glen Parva Manor, Leicester  
 Knight, Josiah. . . . Milwich, Stone, Staffordshire  
 Knight, Richard. . . . Bobbing Court, Sittingbourne  
 Knight, Thomas. . . . Norlington, Lewes  
 Knight, Rev. Thos. H. . . . Broadhayes House, Honiton  
 Knight, W. Edward. . . . 14, Carter Gate, Newark, Notts.  
 †Knighton, Sir W., Bt. . . . Blendworth Lodge, Horndean  
 Knollys, J. E. . . . Fitzhead Court, Taunton  
 Knollys, Gen. Sir W., K.C.B. . . . Blount's Ct., Henley  
 Knowles, James. . . . Wetherby  
 †Knowles, James. . . . Eagley Bank, Bolton  
 Knowles, William. . . . Gloucester  
 Knox, Octavius N. . . . Corrig Lodge, Foynes, Ireland  
 †Kynnersley, C. T. S. . . . High Fields, Uttoxeter  
 Kyrke, Rich. V. . . . Nantyfrith Hall, Wrexham

## L.

Labalmondie, G. . . . 32, Craven Street, Strand, W.C.  
 Lacey, Robert. . . . Hoton, Loughborough  
 †Lake Edward. . . . Hill Side, Strood, Kent  
 Lake, James. . . . Newlands, Teynham, Sittingbourne  
 Lake, John. . . . Edgeworthy, Morchard, Tiverton  
 Lake, Robert. . . . Milton, Canterbury  
 Lakin, Henry. . . . Link End, Malvern  
 Lambe, John. . . . Hopefield, Eccles, Manchester  
 †Lambert, Chas. . . . Sunk Island, Otteringham, Hull  
 †Lambert, H. T. . . . Sandhills, Bletchingley, Redhill  
 Lambert, Wm. Chas. . . . Stepleton Manor, Dorchester  
 †Lancaster, T. . . . Bownham House, Stroud  
 Landor, Walter J. . . . Lee Hall, Rugeley  
 Lane, Ebenezer. . . . Honey Street, Marlborough  
 Lane, John. . . . Winslow Hall, Bucks  
 †Lane, Lieut.-Col. J. H. B. . . . Lilly Hill, Bracknell  
 †Lane, William. . . . Broadfield, Northleach  
 Lang, Thomas M. . . . Barrington Court, Ilminster  
 †Langdale, Lady. . . . Eywood, Kingston  
 Langdale, Sampson. . . . Epsley House, Morpeth  
 Langford, William. . . . Cherbury Hall, Salop.  
 Langham, Herbert. . . . Cottesbrooke, Northampton

†Langton, W. H. P. Gore, M.P. . . . Newton Pk., Bath  
 Larking, John Wingfield . . . The Firs, Lee, Kent  
 Larkman, G. J. . . . Caldecott Hall, Fritton, Lowestoft  
 Larkman, Robert . . . Belton Hall, Great Yarmouth  
 Larkworthy, J. L. . . . Worcester  
 Lascelles, F. H. . . . Mayfield, Rawledge, Farnham  
 †Lascelles, Hon. G. E. . . . Slon Hill, Thirsk  
 Latham, Geo. William . . . Bradwall Hall, Sandbach  
 †Latham, Thomas . . . Little Wittenham, Abingdon  
 Laud, B. H. . . . Bury St. Edmund's  
 †Laurence, William . . . Brockworth Park, Gloucester  
 †Laurie, Andrew . . . 10, Charles St., St. James's, S.W.  
 †Laurie, Reginald Northall . . . Pax Hill Pk., Cuckfield  
 Laverack, Samuel S. . . . Redness Hall, Goole  
 †Law, Rev. R. V. . . . Christian Malford, Chippenham  
 Lawes, John Bennett . . . Rothamsted Park, St. Albans  
 †Lawford, Thomas, jun. . . . London, Canada West  
 †Lawley, Hon. & Rev. S. W. . . . Escrick Rectory, York  
 Lawrence, J. W. . . . Chesterfield Grange, Lichfield  
 †Lawson, C. . . . Borthwick Hall, Gorebridge, N.B.  
 †Lawson, Chas., jun. . . . 34, George Square, Edinburgh  
 Lawson, E. . . . Redesdale Cottage, Newcastle-on-Tyne  
 Lawson, Rev. E. . . . Longhurst Hall, Morpeth  
 Lawson, Sir Wilfrid, Bart. . . . Arkleby Hall, Aspatria  
 †Lawson, William . . . Brayton Hall, Carlisle  
 Lay, Rev. John Ward . . . Hele, Ashburton  
 †Lay, John W. . . . Walcott's, Great Tey, Essex  
 Laycock, Joseph . . . Seghill House, Northumberland  
 Lea, Henry, 316, Bristol Road, Birmingham  
 Lea, James . . . Dodecade Grange, Market Drayton  
 Lea, John . . . Mackley Farm, Sudbury, Derby  
 Lea, John Wheelley . . . Stansfield House, Worcester  
 Lea, Joseph . . . Grove Mount, Davenham, Northwich  
 Lea, R. N. . . . Vernon's Oak, Doveridge  
 Leach, Henry . . . Corston, Pembroke [bray  
 Leadbeater, J. B. . . . Thorpe Satchville, Melton Mow-  
 leamon, Robert . . . Whitwell, Reepham  
 Learmouth, T. L. . . . Park Hall, Linlithgow, N.B.  
 Leather, Simeon . . . Delamere, Northwich  
 †Leaver, Francis . . . Longnor Hall, Penkridge  
 †Lechmere, Sir E. A. H., Bt. . . . Upton-on-Severn  
 Le Cornu, Charles Philip . . . Trinity Manor, Jersey  
 Lee, Charles . . . Newton House, Bedale  
 Lee, Capt. John . . . Woolley Firs, Maidenhead  
 Lee, J. Bunting . . . Stocksfield Hl., Stocksfield-on-Tyne  
 †Lee, J. Lee . . . Dillington House, Ilminster  
 Lee, Joseph . . . Dilston, Corbridge, Northumberland  
 Lee, Joseph Henry . . . Redbrook, Whitechurch, Salop.  
 Lee, Thomas S. . . . Brincton House, Shifnal  
 †Lee, Vaughan H. . . . Lanelay, Llantrissant, S. Wales  
 Leech, George . . . Hunden Great Lodge, Haverhill  
 Leedham, William . . . Andover  
 Leeds, Henry . . . Stibbington, Wansford  
 †Leeds, Robt. . . . Lexham, Castleacre, Brandon  
 Leeke, R. . . . Longford Hall, Newport, Salop.  
 †Lees, Charles . . . 23, Philpot Lane, E.C.  
 Lees, John . . . Reigate  
 Lees, John, Waterloo Road, Wolverhampton  
 Lees, William . . . Gorsty Hill, Crewe  
 †Leese, Charles Stuart . . . Divan Court, Faversham  
 Leese, Spencer . . . West Cliff, Preston, Lancashire  
 Le Feuvre, H. J. . . . Les Nièmes, St. Peters, Jersey  
 Le Gallais, Albert . . . La Moire House, Jersey

Legg, Thomas Fry . . . Burton Bradstock, Bridport  
 †Le Grande, Emile . . . Bale, Switzerland  
 Le Grice, Henry . . . Market Hill, Bury St. Edmund's  
 Leggatt, H. B. . . . Brownwich, Fareham  
 Leggatt, S. B. . . . Crofton, Titchfield  
 Legge, Benj. . . . Court Ho., Litton Cheney, Dorchester  
 Legh, G. Cornwall, M.P. . . . High Legh, Knutsford  
 †Leigh, Col. E. . . . Jodrell Hall, Holmes Chapel  
 Leigh, F. A. . . . Rosegarland, Fouklsmill, co. Wexford  
 Leigh, John Gerard . . . The Hoo, Luton, Beds.  
 Leighton, Robert . . . Thistleyhaugh, Morpeth  
 †Leighton, Stanley . . . Sweeney Hall, Oswestry  
 Lempriere, Rev. William . . . Rozel Manor, Jersey  
 Lenev, Charles . . . Haddon Place, Tonbridge  
 Lenev, Edward . . . Hadlow Place, Hadlow  
 Lennard, Col. J. F. . . . Wickham Court, Bromley, S.E.  
 †Lenton, William, jun. . . . Oundle  
 †Lennard, Sir T. B., Bt. . . . Belhus, Avely, Romford, E.  
 Lennox, William . . . Six Mile Bridge, Newc.-on-Tyne  
 Lenthall, E. Kyffin . . . Besselsleigh Manor, Abingdon  
 Le Page, T. B. . . . Maison de Bas, St. Andrews, Guernsey  
 Lepper, George Andrew . . . Aylesbury  
 Leslie, Charles Powell, M.P. . . . Glasslough, Ireland  
 †Lethbridge, Charles . . . Eastbrook House, Taunton  
 Lett, John . . . Stone Court, Kidderminster  
 Lett, William . . . Rushock, Droitwich  
 Levett, William . . . Glassenbury, Cranbrook  
 Lewes, Col. John . . . Llanliar, Talsarn, Carmarthen  
 Lewes, Rev. Thomas . . . Taynton, Burford, Oxon.  
 Lewis, David . . . Strades, Llanelly, Carmarthen  
 †Lewis, G. . . . Bank House, Worthenbury, Wrexham  
 Lewis, I. H. . . . Gallants Ct., East Farleigh, Maidstone  
 Lewis, J. L. G. P. . . . Henllan, Narberth, Pembroke  
 Lewis, S. . . . Audley, Newcastle-under-Lyme  
 Lewis, Thomas . . . Norchard, Tenby  
 Lewis, T. F. . . . Newport, Monmouthshire  
 Lewis, William . . . Shrewsbury  
 Lewis, W. H. . . . Clynfiew, Newcastle Emlyn  
 Lewis, Wynndham W. . . . Llanishen House, Cardiff  
 Lewisham, Viscount . . . Patshull, Wolverhampton  
 †Lewthwaite, G. . . . Broadgate, Broughton in Furness  
 Lichfield, Earl of . . . Shugborough, Staffordshire  
 Liddell, Hon. H. G., M.P. . . . Ravensworth Castle  
 Lightfoot, F. L. . . . Market Drayton, Salop.  
 Linaker, P. . . . Norton Hill, Preston Brook, Cheshire  
 Lindley, Urban . . . Radmanthwaite House, Mansfield  
 Lindsay, Col. R. Loyd, M. P. . . . Lockinge, Wantage  
 Lindsell, Lieut.-Col. . . . Fairfield House, Biggleswade  
 Linley, William . . . Ham Common, Surrey  
 †Linton, Rev. J. . . . Hemingford Ho., St. Ives, Hunts.  
 Lintott, James, jun. . . . Kimbolton, Hunts.  
 Lintott, Wm. . . . Holmbush, Slinfold, Horsham  
 Linzee, Robert G. . . . Jermyns, Romsey  
 Lister, Charles . . . Coleby Lodge, Lincoln  
 Lister, Edward . . . Cefn Ila, Usk, Mon.  
 Litchfield, John . . . Epperstone, Nottingham  
 Little, Edward . . . Lanhill, Chippenham  
 Little, Hack Magnus . . . Elmington, Oundle  
 †Little, Herbert John . . . Coldham Hall, Wisbech  
 Little, Wm. . . . Vigo House, Chester-le-Street  
 Little, William . . . Littleport, Ely, Cambs.  
 Littledale, Harold . . . Liscard, Liverpool  
 Littler, J. B. . . . Copthorne, Audlem, Cheshire

†Livesey, Rev. Thos...Stourton Hall, Horncastle  
 †Llewellyn, R...Tregwynt, Fishguard, Pembroke  
 †Lloyd, Arthur P...Shawbury, Shrewsbury  
 †Lloyd, Francis...12, Bridge Street, Worcester  
 †Lloyd, J. A...Leaton Knolls, Shrewsbury  
 †Lloyd, John...Kingsbury, St. Albans  
 †Lloyd, John...Bôd Lloyd, Ruabon  
 †Lloyd, Joseph...St. Asaph  
 †Lloyd, Llewellyn...Croesnewydd, Wrexham  
 †Lloyd, Llewellyn F...Nannerch Hall, Mold  
 †Lloyd, Robert...Offmore, Kidderminster  
 †Lloyd, R. T...Aston Hall, Oswestry  
 †Lloyd, W. B...Preston Montford Hall, Shrewsbury  
 †Lobb, Geo., jun...Lawhitton, Launceston, Cornwall  
 †Locker, Wm. T...Aston, Stone, Staffs.  
 †Lockwood, A. C...Chester  
 †Locock, Sir C., Bt...26, Hertford Street, May Fair  
 †Locock, Edmund...South Elkington, Louth  
 †Locock, Fred...9, St. James's Place, S.W.  
 †Loesch, H...Cammerswaldan, Hirschberg, Prussia  
 †Logan, J...11, Lansdown Crescent, Bath  
 †Lombe, Rev. H. E...Melton Hall, Wymondham  
 †Londesborough, Lord...Grimston, Tadcaster  
 †Long, Alexander Wearing...Mint Cottage, Kendal  
 †Long, Daniel...Whaddon, Gloucester  
 †Long, Kellett...Dunstan Hall, Norwich  
 †Long, R. P...Rood Ashton, Trowbridge, Wilts.  
 †Longbourne, W. Y...4, South Sq., Gray's Inn, W.C.  
 †Longcroft, C. J...Havant  
 †Longcroft, C. R...Llanina, Aberayron, Cardigansh.  
 †Longe, John...Spixworth Park, Norwich  
 †Longford, Earl of...Packenham Hall, Westmeath  
 †Longland, James...Grendon, Northampton  
 †Loomes, Edward...Whittlesea, Cambridgeshire  
 †Lopes, Sir Massey, Bart., M.P...Maristow, Roborough  
 †Loraine, Edward...The Riding, Northumberland  
 †Lord, Capt. John P...Great Malvern  
 †Lord, Richard...Stanton Harcourt, Witney  
 †Lott, John...156, Victoria Park Road, N.E.  
 †Louch F. Wm. B...  
 †Lovatt, Henry...Finchfield House, Wolverhampton  
 †Love, Peter...Midland Road, Bedford  
 †Love, S...The Water House, Shoreham, Sevenoaks  
 †Lovell, Edward W. L...Dinder, Wells, Somerset  
 †Lovell, Edwin...Dinder, Wells, Somersetshire  
 †Lovell, Thomas...Winwick Warren, Rugby  
 †Loveridge, Charles...Ivetsey Bank, Penkridge  
 †Loveridge, S...Chapel Ash House, Wolverhampton  
 †Low, George...Burghdown, Athy, Kildare  
 †Lowe, Edward...Comberford Mill, Tamworth  
 †Lowe, John...Ryhall, Stamford  
 †Lowe, John...Whitmore House, Birmingham  
 †Lowe, John...Wheelock Heath, Sandbach  
 †Lowe, Robert N...15, Clarendon Street, Nottingham  
 †Lowe, T...The Old Pale, Eddisbury, Northwich  
 †Lowe, Thomas...Trysall, Wolverhampton  
 †Lowe, Thomas...Calverley Hall, Handley, Chester  
 †Lowe, Thomas Foster...South Croxton, Leicester  
 †Lowndes, Geo. Alan...Barrington Hall, Harlow  
 †Lowndes, W. L...Linley Hall, Bridgnorth, Salop.  
 †Lowther, William, M.P...  
 †Loyd, Lt.-Col. Ed...Lillesden, Hawkhurst, Kent  
 †Loyd, Wm. Jones...Langleybury, Watford

†Loye, P...Kingston Villa, Mannamead, Plymouth  
 †Lucan, Earl of...36, South St., Park Lane, W.  
 †Lucas, Bernard...Chesterfield  
 †Lucas, Rev. C.H...Edith Weston Rectory, Stamford  
 †Lucas, George...Filby House, Great Yarmouth  
 †Lucas, Lieut. Richard...Edith Weston, Stamford  
 †Luckcock, Howard...Edgbaston, Birmingham  
 †Lucy, Rev. J...Hampton Lucy, Stratford-on-Avon  
 †Ludlow, H. G. G...Heywood House, Westbury  
 †Luff, John W...Canford, Wimborne  
 †Lugar, Henry...Ingham, Bury St. Edmund's  
 †Lungley, Brooke M...Peyton Hall, Boxford, Suffolk  
 †Lunn, Robert...Norton, Evesham  
 †Lupton, Arthur...Headingley, Leeds  
 †Lurgan, Lord...Brownlow Ho., Lurgan, Armagh  
 †Lushington, C. Manners...  
 †Lutteroth, Robert...Hamburgh  
 †Luttman-Johnson, J...Gostrode Farm, Chiddingfold  
 †Luttrell, Rev. Alex. H. F...Minehead, Taunton  
 †Luttrell, Col. Badgworth Ct., Weston-Super-Mare  
 †Lyall, William...  
 †Lyne, R. Seager...Compton, Winchester, Hants.  
 †Lyne, Wm...Oddington, Stow-on-the-Wold  
 †Lynes, G. Boulton...Hackleton Ho., Northampton  
 †Lynn, John...Church Farm, Stroxtan, Grantham  
 †Lyon, William...Charlwood, Crawley  
 †Lythall, Frederick...The Spittal Farm, Banbury  
 †Lyveden, Lord...Farming Woods, Thrapstone  
 †Lywood, Edwin...Manor Ho., Maddington, Devises

## M.

†Mabbett, John...Stinchcombe, Dursley, Gloucester  
 †Macadam, Charles T...109, Fenchurch St., E.C.  
 †McCann, George...Court Farm, Malvern  
 †Macclesfield, Earl of...Sherburn Castle, Tetsworth  
 †MacClintock, Maj. H. S...Hillsborough, Co. Down  
 †Macdona, Rev. J. Cumming...Hilbre House, West  
 †Kirby, Birkenhead  
 †MacDouall, Col. James...Logan, Stranraer, N.B.  
 †MacDouall, James, jun...Logan, Stranraer, N.B.  
 †MacDowall, J. C. S...  
 †Mace, J. Ellis...Ashford Road, Tenterden, Kent  
 †Mace, Thomas...Sherborne, Northleach  
 †Macfarlan, Walter...Chapelthorpe, Wakefield  
 †McGeorge, John...Gt. Chart, Ashford  
 †MacGregor, John...Acton, Weaverham, Northwich  
 †Machin, J. Vessey...Gateford Hall, Worksop  
 †McHattie, John...Chester  
 †MacIntosh, David...Havering, Romford, E.  
 †Mackay, A. S. H...Ashton Villa, Ealing Green, Ealing  
 †Mackenzie, E...Fawley Court, Henley-on-Thames  
 †Mackenzie, James...Camden Quay, Cork  
 †Mackenzie, J.H...Northwood, West Hoathley, Sussex  
 †Mackenzie, William...34, Dawson Street, Dublin  
 †Mackinder, Harwood...Langton Grange, Spilsby  
 †Mackinder, Herbert...Mere Hall, Lincoln  
 †MacLagan, Peter, M.P...Pumpherstone, Midcalder  
 †McLaren, Henry...Offerton Hall, Sunderland  
 †McLaren, Wm...Low Burn Hall, Durham  
 †McLaughlin, W. G...Helmsley, York  
 †Macleod, Norman...

MacNiven, Charles...Perrysfield, Oxted, Surrey  
 Madan, Martin...Haselour, Tamworth  
 Maddison, George Wilson...Partny, Spilsby  
 Madgwick, Wm., jun...Alciston, Lewes  
 Mahon, H. J. P...Strokestown House, Roscommon  
 Mainwaring, Charles S...Galltfaenan, Rhyl  
 Mainwaring, T...Galltfaenan, Denbigh  
 Maitland, Col. F. T...Hollywych, Edenbridge  
 Makgill, George...Prestbury, Cheltenham  
 Malcolm, Maj.-Gen. G. A...67, Sloane Street, S.W.  
 Malcolm, John...7, Great Stanhope Street, W.  
 Malcolm, M...Manor House, Kineton  
 Male, Henry...East Chinnock, Yeovil  
 Mallock, C. H...Court House, Cockington, Torquay  
 Malmsbury, Earl of...Heron Court, Christchurch  
 Manchester, Duke of...Kimbolton Castle, Hunts.  
 Mansfield, W...Ixworth Thorpe, Bury St. Edmund's  
 Mangles, F...  
 Mangles, George...Givendale Grange, Ripon  
 Manon, M. Hervé...69, Rue St. Dominique, Paris  
 Manley, Augustus East...Manley Hall, Lichfield  
 Manley, Maj. R. G...Upton House, Kineton  
 Mann, John...Thornage, Thetford  
 Manners, Lord G., M.P...Cheveley Pk., Newmarket  
 Manning, John...Orlingbury, Wellingborough  
 Mannings, George...Downton, Salisbury  
 Mannington, Wm...Laughton Place, Hurst Green  
 Mannsfield, Count...Dobrich, Prague, Austria  
 Mansell, Andrew...Little Ness, Baschurch, Salop.  
 Mansell, Edward...27, Great George Street, S.W.  
 Mansell, Sir J. Bt...Maesdilo, Llandilo, Carmarthen  
 Mansell, Thomas...Adcott Hall, Baschurch Salop.  
 Maple, John...Bedford Lodge, Hampstead, N.W.  
 Maplebeck, W. B...6, Bull Ring, Birmingham  
 Margary, Maj. A. R...Chartham Pk., E. Grinstead  
 Margesson, Rev. W...28, St. Leonard's Ter. Chelsea  
 Margetts, Charles...Huntingdon  
 Margetts, John...High Street, Warwick  
 Marjoribanks, D. C...Bushey Hall Farm, Watford  
 Marjoribanks, Edward, jun...59, Strand, W.C.  
 Markby, John Randall...9, Whitehall Place, S.W.  
 Markler, Richard...Combe, Devon  
 Markham, Charles, jun...Northampton  
 Markham, Lt.-Col. W. T...Becca Hall, Milford Junc.  
 Marriage, John...Moulsham Lodge, Chelmsford  
 Marriott, Capt. E. J. Beckett...Burford, Oxon.  
 Marriott, John L...Narborough, Brandon  
 Marriott, W. M...Kibworth, Market Harborough  
 Marry, Thomas...The Chase, Uceby  
 Marsh, Matthew H...Ramridge, Andover  
 Marsh, Richard...Little Offley House, Hitchin  
 Marsh, Wm. Jas...Loridge, Berkeley, Gloucestershire  
 Marshall, Arthur...Headingley, Leeds  
 Marshall, Rev. C...9, South St., Finsbury Sq., E.C.  
 Marshall, Edmond Henry...Westwood Hall, Leeds  
 Marshall, Frederick Charles...Riseholme, Lincoln  
 Marshall, George Hibbert...  
 Marshall, H. J...Poulton Priory, Cricklade  
 Marshall, James...Gainsborough  
 Marshall, James...Low Horton, Cramlington  
 Marshall, James Garth...Headingley, Leeds  
 Marshall, William Francis...Branston Villa, Lincoln  
 Marsham, Robert, D.C.L...Merton College, Oxford

† Marsland, W...Baguley, Northenden, Manchester  
 Marson, John...Acton Mill, Stafford  
 Marten, John...Chilham, Canterbury  
 Marten, Peter...Chilham, Canterbury  
 † Martin, Antoine...Malagnon, Geneva  
 Martin, David...Wainfleet, Lincolnshire  
 Martin, E. Hall, jun...Barr Hill, Madeley, Staffs.  
 † Martin, E. Waterer...Nonsuch Park Farm, Ewell  
 † Martin, F. P. B...Oxford & Cambridge Club, S.W.  
 † Martin, George...Hubert's Bridge, Boston  
 † Martin, Gilson...Bedford Office, Tavistock  
 Martin, Henry B...Colston Basset, Bingham, Notts.  
 † Martin, Henry W...Littleport, Isle of Ely  
 † Martin, James...Wainfleet, Boston  
 † Martin, J...Highfield Ho., Littleport, Isle of Ely  
 † Martin, Robert...Asterby, Horncastle  
 Martin, S. D...1, Park Place, Leeds  
 † Masfen, R. Hanbury...Pendeford, Wolverhampton  
 Masfen, William...Norton Caines, Cannock, Staffs.  
 Mashiter, Thomas...Priest's, Romford, E.  
 † Mason, James...Eynsham Hall, Witney  
 Mason, Richard...Kedington, Louth  
 † Master, Charles H...Barrow Green House, Godstone  
 Master, Col. Thomas C...The Abbey, Cirencester  
 Masterman, Thos. J...Little Danby, Northallerton  
 Masterman, T. W...Claremont, Tunbridge Wells  
 Masters, Albert E...Nixendon Hall, Chelmsford  
 Mather, Daniel...Chipping Norton, Oxon.  
 † Mather, Myles E...Glyn Abbot, Holywell  
 † Matheson, Sir J., Bt...The Lewes Island, N.B.  
 Mathew, Edward Windus...Wern, Portmadoc  
 Mathew, William...Knettishall, Harling  
 Mathews, Augustus...Pitchcombe View, Stroud  
 † Mathews, Jeremiah...Edgbaston Ho., Birmingham  
 † Matson, W. Bawtree...  
 Matthews, C...Cleveland Road, Wolverhampton  
 Matthews, Francis Cook...Driffield  
 Matthews, Henry...Montford, Shrewsbury  
 Matthews, John, M.D...Tynemouth  
 † Matthews, T...Newton by Castleacre, Brandon  
 Maud, Chas. T...Waterhouse, Bath  
 Maude, Col. G. A...Stud Farm, Hampton Court  
 Mawer, Edward...Wyrdelands, Thorney, Peterboro'  
 † Maxse, Capt. F. A., R.N...Holly Hill, Southmptn.  
 Maxwell, Sir John H., Bt...Springkell, Ecclefechan  
 Maxwell, Hon. M. Constable...Terregles, Dumfries  
 Maxwell, J. R. Heron...Springkell, Ecclefechan, N.B.  
 † Maxwell, R. C. H...Springkell, Ecclefechan, N.B.  
 † Maxwell, W. H., M.P...Munches, Dalbeattie, N.B.  
 May, Chas. Neale...Dezives  
 † May, George Anderson...Elford Park, Lichfield  
 Mayman, B...Water St., Liverpool.  
 Maynard, Robert...Whittlesford, Cambridge  
 Mayo, Henry...Cokers Frome, Dorchester  
 Mayou, J. Webster...Fazeley, Tamworth  
 Meade, W. R...Ballymartle, Kinsale, co. Cork  
 Meakin, H. J...Shobnall Grange, Burton-on-Trent  
 Mechi, John J...112, Regent Street, W.  
 † Medlicott, Sir W. C., Bt...Milborne Port, Sherborne  
 Meeson, William Taylor...Doggetts, Rochford  
 Mein, William...Brewood, Stafford

- Mellard, Ralph... Rugeley, Staffordshire  
 Mello, William... Chadwell, Ware  
 Mellersh, T. G... 2, Southfield Villas, Cheltenham  
 Mellows, William... High Melton, Doncaster  
 Melville, Hon. A. Leslie... Branston Hall, Lincoln  
 †Melville, Alex. S. Leslie... The Longhills, Lincoln  
 †Melville, Charles Leslie... Branston Hall, Lincoln  
 Menzies, George... Trentham, Stoke-on-Trent, Staffs.  
 Mercer, F... 28, Clayton St. West, Newc.-on-Tyne  
 †Mercer, James, M.D...  
 †Mercer, William... Newton, Warrington  
 Mercer, William... Grove Ho., Hunton, Staplehurst  
 Meredith, David... Yeatsall, Rugby  
 Meredith, J... The Hildra, Welsh Pool  
 †Merriman, Edward B... Marlborough  
 †Merriman, Thomas Baverstock... Marlborough  
 †Merriman, William Clark... Marlborough  
 Merson, James... South View House, North Molton  
 †Mertens, Baron Edward... Rue Ducale, Brussels  
 †Metcalfe, Charles James...  
 Methuen, Lord... Corsham Court, Chippenham  
 Mewburn, William... Wykham Park, Banbury  
 †Meyer, Herman P. D... Little Laver Hall, Ongar  
 †Meyer, James... Forty Hall, Enfield, N.  
 †Meyer, P. Herman... Stonder Place, Brentwood  
 Meyrick, Owen Fuller... Bodergau, Anglesey, N. W.  
 Michell, John... Forcett Park, Darlington  
 †Michell, E. W., jun... Shirley Vicarage, Derby  
 †Micklethwait, Rev. J... Taverham Hall, Norwich  
 Middleditch, E. Taylor... Blandson Ho., Hghworth  
 Middlemore, Colonel... Thorngrove, Worcester  
 Middlemore, Mrs... Thorngrove, Worcester  
 †Middleton, Charles... Holkham  
 †Middleton, Henry... Cutteslowe, Oxford  
 Middleton, Saville... Water Newton, Hunts.  
 Middieton, W. Wiley... Fritcham Abbey, Lynn  
 †Midgley, W. H... Inchbrook, Malvern Link  
 Milbank, A. S... Barningham Pk., Barnard Castle  
 Milburn, Robert... 76, Church Lane, Whitechapel  
 †Mildred, Daniel... Preston, Cirencester  
 †Mildmay, Sir H. St. J. Bt... Dogmersfield, Winchfield  
 †Miles, Charles William... Burton Hill, Malmesbury  
 †Miles, Grosvenor... Bourton House, Rugby  
 †Miles, John William... King's Weston, Bristol  
 †Miles, P. W. S... 61, Queen's Square, Bristol  
 Miles, Roger Dutton... Keyham, Leicester  
 Miles, Thomas... Keyham, Leicester  
 †Miles, William... Dix's Field, Exeter  
 Milford, Thomas... Thorverton, Cullompton  
 †Miller, Bartlett... Moulton, Northampton  
 Miller, G. Seymour... Bradpole, Bridport  
 Miller, J. Norton... Pattingham, Wolverhampton  
 Miller, Samuel... Abermule, Montgomery  
 Miller, Thomas... Bitteswell Hall, Lutterworth  
 Miller, T. H... Singleton, Kirkham, Lancashire  
 Mills, John... Bisterne, Ringwood  
 Mills, John... Pinkneys Green, Maidenhead  
 †Mills, J. R... Kingswood Lodge, Tunbridge Wells  
 †Mills, Joseph T... Husband's Hosworth, Rugby  
 Mills, R. W. F... Sendal, York  
 †Mills, Wm... Saxham Hall, Bury St. Edmund's  
 Milne, David... Paxton House, Berwick  
 Milne, Oswald, jun... Tennis Court Club, Leamington  
 Milner, John... Myerscough, Preston  
 Milward, Dawson A... Tullogher, New Ross  
 Milward, Richard... Thurgarton Priory, Southwell  
 Minet, Charles Wm... 41, West Smithfield, E.C.  
 Minett, J. E... Llowley Hall, Fillongley, Coventry  
 Minor, A. H...  
 Minor, John... The Grove, Kingsland, Shrewsbury  
 Minton, Alfred... The Lawn, Datchet, Bucks.  
 Mitchell, Andrew... Alloa, Clackmannanshire, N.B.  
 †Mitchell, F. J... Llanfrecfa, Newport, Mon.  
 Mitchell, John... The Beacon, Penkridge  
 Mitchell, John Jackson... Wigton  
 Mitchell, William... Northwold, Brandon  
 †Mitford, Wm. Townley, M.P... Pitshill, Petworth  
 Moffat, James... Kirklington Park, Carlisle  
 Molyneux, James More... Losely Park, Guildford  
 †Monck, J. Bligh... Coley Park, Reading  
 Monckton, E... The Hectorage, Tonbridge  
 †Monckton, E. H. C... Fineshade Abbey, Northamp.  
 †Monckton, Francis... Stretton Hall, Penkridge  
 Monckton, Frederick... Hadlow, Tonbridge  
 Monks, James... Aden Cottage, Durham  
 Monro, Mordaunt Martin... Enfield  
 Montgomery, Rev. R... Milton, Northampton  
 Moody, General... Caynham House, Ludlow  
 †Moore, Rev. Edward... Theobalds, Hawkhurst  
 Moore, Edward Wells... Coleshill, Faringdon  
 Moore, George... Appleby Hall, Atherstone  
 Moore, George... White Hall, Wigton  
 †Moore, Rev. G. Bridges... Tunstall, Sittingbourne  
 †Moore, Henry... Eimley Castle, Pershore  
 Moore, Henry... Bilboro, Notts.  
 Moore, James... 11, Upper Berkeley St., Portman Sq.  
 Moore, John... Kerry, Montgomery  
 Moore, John... Church Street, Warwick  
 Moore, John... Calverton, Notts.  
 Moore, J... Northumberland House, Charing Cross  
 Moore, Robert... Rye Hill, Church Eaton, Stafford  
 †Moore, Thomas William... Warham, Wells, Norfolk  
 Moore, Wm... Elm House, Elm, Wisbeach  
 Moore, William W... Tewkesbury  
 †Moorsom, C. R... Harewood, Leeds  
 Morant, George... Farnborough, Hants.  
 More, R. Jasper... Bishop's Castle, Salop.  
 †Morgan, Col. the Hon. F. C... Newport, Mon.  
 †Morgan, Maj. the Hon. G. C., M.P... Cardiff  
 Morgan, M... Coppy Crooks, Bishop Auckland  
 Morgan, Richard... Newtown, Montgomeryshire  
 Morgan, Roger... Llanellan, Abergavenny  
 Morgan, Thomas... 39, Faulkner Street, Manchester  
 Morison, Alex. John, M.D... Portleu, Pembroke  
 Morland, George Bowes... Abingdon  
 Morland, W. Courtenay... Court Lodge, Lamberhurst  
 Morley, Earl of... Saltram, Plympton  
 †Morley, E... Brize Norton, Bamptou, Faringdon  
 †Morley, Henry H... Craven Lodge, Stamford Hill  
 Morley, William... Haddon, Bampton, Faringdon  
 †Morrell, Frederick J... St. Giles's, Oxford  
 †Morrice, J. W... The Tower, Calthorpe, Rugby  
 Morris, Abiathar... Pendeford Ho., Wolverhampton  
 Morris, James... Union Place, Oswestry  
 Morris, John... Town House, Madley, Hereford  
 Morris, Sir John... Wightwick Ho., Wolverhampton



† Morris, Col. Lewis G. . . . Morrisania, New York  
 † Morris, Norman . . . Ford, Lingfield, Surrey  
 Morris, Richard . . . Knockin Heath Farm, Oswestry  
 † Morris, Thos., jun. . . . Walcote Fields, Lutterworth  
 Morris, Thomas . . . Maisemore, Gloucester  
 † Morris, Thomas . . . Henfaes, Welshpool  
 Morris, Walter . . . Dewsal Court, Hereford  
 Morris, William . . . Carmarthen  
 Morris, W. Rudkin . . . Silverlands, St. Leonard's  
 † Morrison, Charles . . . Basildon Park, Reading  
 † Morrison, F. . . . Cromwell Houses, South Kensington  
 † Morrison, Walter, M.P. . . . Malham Tarn, Skipton  
 Morrison, William H. . . . Wood Hall, Barnsley  
 Morshead, Sir Warwick, Bt. . . . Forest Lodge, Binfield  
 Mort, William . . . Marton, Baschurch, Salop.  
 Morton, Francis . . . 36, Parliament Street, S.W.  
 Morton, Henry Thos. . . . Biddick Hall, Fence Houses  
 Morton, John Chalmers . . . Harrow, N.W.  
 † Morton, J. D. . . . 19, Parliament Street, S.W.  
 Morton, J. T. . . . Darenth, Dartford  
 Moscrop, W. J. . . . Aske, Richmond, Yorkshire  
 † Moseley, Captain W. H. . . . Leaton Hall, Stourbridge  
 Mosley, Sir T., Bart. . . . East Lodge, Burton-on-Trent  
 Moss, Benjamin . . . Ashington Hill, Rochford  
 Mostyn, Sir P., Bt. . . . Talacre, Holywell, Flintshire  
 † Mott, Charles John . . . Clifton-upon-Dusmore, Rugby  
 Mott, Thomas . . . Much Hadham, Ware  
 Mott, William . . . Wall, Lichfield  
 Moulte, Wm. . . . Knowsley, Prescott, Lancashire  
 Mount Edgumbe, Earl of. . . . Mt. Edgumbe, Devon.  
 † Mount, W. G. . . . Wasing Place, Reading  
 Mourant, Edward . . . Samare's Manor, Jersey  
 Mousley, Geo. . . . Hooton Hall, Chester  
 Mousley, Thomas Turner . . . Well Field, Carmarthen  
 † Mowbray, Capt. . . . Overseal, Ashby-de-la-Zouch  
 Mowbray, S. . . . Kilbany, Mountrath, Ireland  
 Moxon, Thomas David . . . Easenhall, Rugby  
 † Moysey, H. G. . . . Batheston Court, Wiveliscombe  
 † Mucklow, E. . . . Castle Head, Grange, Lancashire  
 Mudford, Joseph . . . Hoe Fields, Hinckley  
 Muirhead, Thomas . . . 20, Victoria Street, Manchester  
 Mumford, George S. . . . Lavenham, Sudbury  
 Mumford, J. A. . . . Chilton Park Farm, Thame  
 † Mumford, Maurice . . . Creeting, Stowmarket  
 † Mumford, William . . . Credenhill, Hereford  
 † Mumford, William Henry . . .  
 Mundy, C. J. Massingberd . . . Old Bolingbroke, Spilsby  
 Mundy, William . . . Markheaton, Derby  
 † Munn, Fred. . . . Holt Castle, Worcester  
 † Munn, Maj. W. A. . . . Churchill House, Dover  
 † Muntz, G. F. . . . Umberslade Park, Birmingham  
 † Murray, A. . . . 74, St. George's Rd, Belgravia, S.W.  
 Murray, Gilbert . . . Elvaston Castle, Derby  
 Murray, William . . . Lower Boughton, Manchester  
 Murton, Frederick . . . Smeeth, Ashford  
 Murton, Thomas . . . Kenninghall, Thetford  
 Murton, William . . . Tunstall, Sittingbourne  
 † Musgrave, Sir Geo., Bart. . . . Edenhall, Penrith  
 Musgrave, J. . . . Wasdale, Holmbrook, Cumberland  
 Musgrave, R. C. . . .  
 Musgrave, Rev. Vernon . . . Hascombe, Godalming  
 Muskett, Chas. . . . Bressingham Park, Diss  
 † Musters, John C. . . . Annesley House, Linby, Notts.

† Mynors, R. . . . Weather Oak, Alvechurch, Bromsgrove  
 † Mynors, W. C. T. . . . Elford Lowe, Tamworth  
 Myott, James . . . Copesthorpe, Congleton  
 † Mytton, D. H. . . . Garth, Welshpool

N.

† Nainby, Charles M. . . . Barnoldby le Beck, Grimsby  
 † Naish, W. B. . . . Stoneaston, Bath  
 Nalder, Jas. Hall . . . Haseley Iron Works, Tetsworth  
 Nalder, Thomas . . . Challow, Wantage  
 † Nall, Joseph . . . Hoveringham House, Nottingham  
 Naper, Jas. L. . . . Loughcrew, Oldcastle, Ireland  
 † Napier, Edw. B. . . . Pennard House, Shepton Mallet  
 Napper, John . . . Ifold, Horsham  
 Nash, Charles . . . Royston, Herts.  
 Nash, Daniel . . . 4, York Gate, Regent's Park, N.W.  
 Nash, John . . . The Rectory, Langley, Slough  
 Nash, Henry F. . . . Upton Lea, Slough  
 † Nathusius, Baron G. . . . Hundisburg, Prussia  
 † Naylor, John . . . Liverpool  
 † Naylor, Rich. Christopher . . . Hooton Hall, Chester  
 Neale, Charles . . . Screveton, Bingham  
 Neale, Charles James . . . Mansfield, Notts.  
 † Neame, E. . . . North Court, Lower Hardres, Canterbury.  
 † Neame, Edwin . . . Harefield, Selling, Faversham  
 Neame, Frederick . . . Macknade, Faversham  
 † Neame, H. B. . . . Selling Court, Faversham  
 Neame, P. B. . . . The Mount, Ospringe, Faversham  
 Neame, Robert . . . Boughton Bleau, Faversham  
 † Negus, Thomas A. . . . Lynn House, Walsall, Staffs  
 Neild, Henry . . . The Grange, Worsley, Manchester  
 Nelson, John . . . Kettleby Thorpe, Brigg  
 † Nelson, John . . . Wytham House, Louth  
 Nelmes, William . . . Pembroke Castle, Monmouth  
 Nelson, T. . . . Catgill Hall, Egremont, Cumberland  
 Nesfield, R. M. N. . . . Castle Hill, Bakewell  
 Nesham, David . . . The Hall, Gainford, Darlington  
 † Nethercote, H. O. . . . Moulton Grange, Northampton  
 Neve, C. . . . Amberfield, Chart Sutton, Staplehurst  
 Neve, George . . . Sissinghurst, Staplehurst  
 † Neve, Richard . . . Benenden, Staplehurst  
 Nevell, Edward . . . Chawley Farm, Cumnor, Oxford  
 Nevett, Wm. . . . Yorton, Harmer Hill, Shrewsbury  
 † Nevile, Rev. Christopher . . . Thorney, Newark, Notts  
 † Nevile, George . . . Shelton, Newark-on-Trent  
 Neville, J., jun. . . . Lea End, Alvechurch, Redditch  
 New, David . . . Waverley House, Nottingham  
 New, Richard E. . . . Hartpury, Gloucester  
 † Newall, Henry . . . Hare Hill, Littlehoro', Lancashire  
 † Newbery, R. P. . . . Webbe House, Chard, Somerset  
 Newcombe, Samuel . . . White Crofts, Orsett, Essex  
 Newdegate, C. N., M.P. . . . Arbury, Nuneaton  
 † Newdigate, W. F. . . . Byrkley, Burton-on-Trent  
 Newhouse, Henry . . . Tatton Park, Knutsford  
 Newill, Joseph . . . Lydbury North, Salop.  
 Newill, Thos. . . . Spring Bank, Welshpool  
 Newman, James . . . Shipton Lee, Quainton, Bucks.  
 † Newman, J. . . . Brands Ho., High Wycombe, Bucks.  
 Newman, Thomas . . . Cray's Marsh Farm, Melksham  
 † Newport, Henry A. W. . . . Cotton Hall, Bridgnorth

Newton, Chas. E. . . . Mickleover, Derby  
 †Newton, G. Onslow . . . Croxted Park, St. Neot's  
 Newton, John . . . Manor Road, Bermondsey, S.E.  
 Newton, Martin . . . Oldfield, Altrincham  
 †Newton, R. J. . . . Campsfield, Woodstock  
 †Newton, S. C. . . . The Downs, Croxton, St. Neot's  
 †Newton, Thomas . . .  
 Newton, Thomas . . . Oldfield, Altrincham  
 Newton, T. H. G. . . . Barrell's Park, Henley-in-Arden  
 Nicolls, William H. . . . Newnham, Shrewsbury  
 Nicholay, J. A. . . . Victoria Oil Mills, West Drayton  
 †Nicholl, G. W. . . . The Ham, Llantwit, Cowbridge  
 Nichols, Ben. . . . West End Farm, Aldershot  
 Nicholson, B. . . . Stourton Grange, Garforth, Leeds  
 Nicholson, Clement. . . . Cheadle, Hulme, Manchester  
 Nicholson, Geo. . . . Winlaton, Blaydon-on-Tyne  
 †Nicholson, James . . . Blencairn Hall, Penrith  
 Nicholson, J. . . . Kirkby Thore Hall, Westmoreland  
 Nicholson, Capt. S. . . . 74, Holland Park, W.  
 †Nicholson, W. . . . 4, Sussex-square, Hyde Park, W.  
 Nicholson, Wm. Nurzam . . . Newark-upon-Trent  
 Nickisson, John . . . 103, Friar Gate, Derby  
 Nickolls, James . . . Tuck Hill, Bridgnorth  
 Nicks, William . . . Greville House, Gloucester  
 Nicol, James D., M.P. . . . 13, Hyde-Park Terrace, W.  
 †Nightingale, Vaughan E. . . . Burway, Ludlow  
 †Nightingale, W. E. . . . Embley, Romsey  
 Nisbet, Ralph Pattison . . . Thorney, Peterborough  
 †Noakes, John Tompsett . . . Brockley Ho., Lewisham  
 Nock, Charles . . . Norton, Shifnal  
 Nock, Thomas . . . Sutton Maddock, Shifnal  
 Nock, T. F. . . . Kingslow, Bridgnorth  
 Noel, Captain C. Perrat . . . Bell Hall, Stourbridge  
 Nodder, Rev. J. . . . Marsh Green, Chesterfield  
 Norfolk, Richard . . . Iron Works, Beverley  
 Norman, Geo. . . . Dinnaton, Swimbridge, Barnstaple  
 †Norman, George Warde . . . Bromley, Kent, S.E.  
 †Norman, J. Newcomb . . . Harborough Magna, Rugby  
 Norman, William . . . Hall Bank, Aspatria  
 †Normanby, Marquis of . . . Mulgrave Castle, Whithy  
 †Norreys, Viscount . . . Wytham Park, Oxford  
 †Norris, William . . . Wood Norton, Fakenham  
 Norris, W. G. . . . Coalbrookdale, Wellington, Salop.  
 North, Charles . . . South Thoresby, Alford  
 North, Charles . . . The Hall, Rougham, Norfolk  
 North, Lieut.-Col., M.P. . . . Wroxton Abbey, Banbury  
 †Northcote, Rt. Hon. Sir S., Bt., M.P. . . . Pynes, Exeter  
 Northey, Edward Richard . . . Epsom  
 †Northumberland, Duke of . . . Alnwick Castle  
 †Nott, James . . . Penn Hall, Eardiston, Tenbury  
 †Nottidge Josias . . . Iden Rectory, Rye  
 Nowell, W. A. . . . Netherside, Skipton, Yorkshire  
 Noyes, Thomas H. . . . 13, Gate Street, Lincoln's Inn  
 Nunn, Edmund B. . . . Royston, Cambs.  
 Nunn, G. H. . . . Eldo House, Bury St. Edmund's  
 Nunnerley, John . . . Buerton Hall, Nantwich  
 Nunnerley, T. . . . Bradley Green, Whitchurch, Salop.  
 †Nutt, John . . . White House, Fillongley, Coventry  
 Nuttall, James . . . Chaddesden, Derby  
 Nuttall, Thomas . . . Manor House, Beeby, Leicester

## O.

Oakes, Hervey Asten . . . Stowmarket  
 Oakes, Thos. Haden . . . Riddings House, Alfreton  
 †Oakley, Christopher . . . 10, Waterloo Place, S.W.  
 †Oakley, George . . . Lawrence End, Luton  
 Oakley, John . . . 10, Waterloo Place, S.W.  
 Oastler, Jonah . . . White's Farm, Alford, Horsham  
 †Ockleston, Wm. Fairhurst . . . Cheadle, Manchester  
 Odams, James . . . 109, Fenchurch Street, E.C.  
 †Ogden, John Maude . . . Sunderland  
 †Ogilvie, Alexander . . . Sizewell House, Leiston  
 Ogilvie, John D. . . . Mardon, Coldstream, N.B.  
 Ogilvy, Sir J., Bt., M.P. . . . Baldovan Ho., Dundee, N.B.  
 †Ohry, H. G. Jun. . . . Downside, Ventnor  
 Oldacres, Matthew . . . Clipston, Market Harborough  
 Oldacres, Walter . . . Broad Fields, Lichfield  
 †Oldfield, Edmund . . . Fouldon Hall, Brandon  
 Oldham, John . . . Carlton-on-Trent, Notts.  
 Oldrin, John . . . Rushmere, Wangford, Suffolk  
 Oliphant-Ferguson, G. H. H. . . . Broadfield, Carlisle  
 †Oliver, John . . . Oxenden, Northampton  
 Oliver, Robert E. . . . Sholbrooke Lodge, Towcester  
 Olver, Richard Sobey . . . Trescowe, Bodmin  
 O'Neil, William . . . Athy, Kildare, Ireland  
 Orbell, William . . . Hawstead, Suffolk  
 Ord, George . . . Brixton Hill, S.W.  
 Ord, Rev. J. A. B. . . . Whitfield Hall, Haydon Bridge  
 Orde, Charles William . . . Nunykirk, Morpeth  
 †Orde, Sir J. P. W., Bt. . . . Kilmorey Ho., Loch Gilp Head  
 Orlebar, H. A. . . . West Hoathley, East Grinstead  
 Ormerod, George . . . Seabury Park, Chepstow  
 Ormerod, Henry Mere . . . 5, Clarence St., Manchester  
 Ormond, Francis . . . Moulton Park, Northampton  
 Ormston, Robert . . . Newcastle-on-Tyne  
 †Osborn, G. . . . Manor Ho., Pattishall, Towcester  
 Ostler, John, jun. . . . Walron Park, Taunton  
 †Oswell, W. B. . . . Eardiston House, West Felton  
 †Ortrante, Count A. . . . Nygard, Söderköping, Sweden  
 †Overman, Henry R. . . . Weasenham, Fakenham  
 †Overman, John . . . Burnham Sutton, Norfolk  
 †Overman, Robert . . . Edgmere, Walsingham, Norfolk  
 Owen, Charles Mostyn . . . Walton House, Oxford  
 Owen, Griffith H. . . . Ymwlch, Tremadoc  
 Owen, William . . . Blesinton, Ireland  
 Owen, William . . . Moorgate Hall, Rotherham  
 Owen, William . . . Withy bush, Haverfordwest  
 Owens, Samuel . . . Whitefriars Street, E.C.  
 Owston, Hiram A. . . . Great Wigston, Leicester  
 Oxley, John Stewart . . . Fen Place, Worth, Sussex

## P.

†Packard, Edward . . . Ipswich  
 †Packe, George H. . . . Caythorpe Hall, Grantham  
 †Packe, Dr. James . . . Melton Lodge, Woodbridge  
 Paddison, Edward . . . Ingilby, Lincoln  
 Padmore, Richard . . . Worcester  
 Padwick, Fred . . . West Thorney, Emsworth, Hants.  
 Page, Edward . . . Bedford  
 Page, Francis . . . Uttoxeter  
 †Page, Henry . . . Walmer Court, Walmer

Page, Joseph...Stoke Ho, Stoke Prior, Bromsgrove  
 Page, William, jun....Southminster, Maldon  
 Paget, Charles...Ruddington Grange, Nottingham  
 †Paget, Col. L. G....Park Homer, Wimborne  
 †Paget, Maj. R.H., M.P..Cranmore Hill, Shepton Mallet  
 †Paget, T. Tertius...Humberstone, Leicestershire  
 Pain, John...Popham, Micheldever Station  
 Paine, T...The Grove, Basingstoke  
 Paine, G. J...Risby, Bury St. Edmund's  
 †Paine, Mrs....Farnham, Surrey  
 Paine, William D...Chevington, Bury St. Edmund's  
 †Paine, Wm. Dunkley...Cockshutt Hill, Reigate  
 Painter, Benjamin...Burley-on-Hill, Oakham  
 Painter, John...Forest Road, Nottingham  
 Painter, Robert...18. Gallowtree Gate, Leicester  
 Paisson, William...Irish Street, Whitehaven  
 Pakington, Rt. Hon. Sir John, Bt., M.P...Droitwich  
 †Pain, William...Wilcote House, Shrewsbury  
 Palmer, C. M...Newcastle-on-Tyne  
 Palmer, George...Greenwood, Bishop's Waltham  
 Palmer, George...Hawstead, Bury St. Edmund's  
 †Palmer, Rev. P. H...Wolthorp Rectory, Grantham  
 Palmer, Robert...Bexington, Bridport  
 Palmer, Robert...Nagington, Market Drayton  
 Palmer, Sir R. W. H...Cefn Pk., Wrexham, Denbigh  
 †Papillon, P. O...Manor House, Lexden, Colchester  
 Papillon, Thomas...Crowhurst Park, Battle  
 Paramore, J. Rawle...Preswyla, Neath  
 Park, James...Lightburne, Ulverstone  
 Parke, William...Stragglethorpe, Newark  
 Parker, James S...Ifley, Oxford  
 Parker, John O...Drinkstone, Woolpit  
 Parker, Rowland...Moss End, Burton, Westmoreland  
 Parker, Thomas...Aldford, Chester  
 †Parker, Thomas Holme...Warwick Hall, Carlisle  
 Parker, Thomas James...10, George St., Sheffield  
 Parker, T. Sumner...Oxton, Southwell  
 Parker, T. Towneley...Charnock, Chorley, Lancashire  
 †Parker, William...Carlton Hill, Penrith  
 Parker, William...The Park, Ware  
 Parker, Rev. W...Rectory, Little Comberton, Pershore  
 Parker, Major W., M.P...Clopton Hall, Woolpit  
 Parkes, Thomas...Grafton Manor, Bromsgrove  
 Parkin, John...Idridgehay, Wirksworth  
 Parkin, John...Goldthorpe, Worksop, Notts.  
 Parkin, P. W...Ridgemount, Bassett, Southampton  
 †Parkinson, John...  
 †Parkinson, R...Oak Ho, Northenden, Manchester  
 †Parkinson, Thomas...Hexgreave Park, Southwell  
 †Parkyns, Sir Thos. G. A., Bt...Ruddington, Notts.  
 Parmeter, Francis, junr...Brynyraber, Bala  
 Parr, Herman...Barton, Nottingham  
 †Parr, John...Cropwell Butler, Bingham  
 Parr, Samuel...The Park, Nottingham  
 †Parr, W. Fillingham...Cropwell Butler, Bingham  
 Parr, Capt. R. W...Grappenhall Hayes, Warrington  
 Parrington, John...Brancepeth, Durham  
 †Parris, John W...Farnham, Bishop Stortford  
 Parrish, Richard...Uplands Farm, Bridgnorth  
 Parrott, Edward...Shirburn, Tetsworth  
 Parrott, John, junr...Stony Stratford  
 Parrott, Thos...Green Bank, Sutton, Macclesfield  
 †Parry, Joseph...Allington, Devizes

Parry, Nicholas...Little Hadham, Ware  
 Parson, Edgcombe...Coates, Cirencester  
 Parson, Rev. W. H...Lynchmere Rectory, Haslemere  
 Parsons, Charles William...Anstrey, Atherstone  
 Parsons, C...North Shoebury Hall, Rochford  
 †Parsons, Geo...Martock, Somerset  
 †Parsons, Henry...Halsbury, Crewkerne  
 †Parsons, Herbert...Elsfeld, Oxford  
 †Parsons, John...Ifley, Oxford  
 Parsons, J. P...Wood Farm, Honingham, Norwich  
 Parsons, William...Hill Farm, Elsfield, Oxford  
 Partridge, Charles...Clyra House, Hay  
 Partridge, John...Bishop's Wood, Ross  
 Pashley, Alexander William...Haddiscoe, Lottstoft  
 Paske-Jones, George...3, Euston Place, Leamington  
 †Paterson, Richard...Leesons, Chiselhurst  
 †Pateshall, Evan...Allensmore Court, Hereford  
 †Patmore, James...Hockerhill, Bishop Stortford  
 Pattenson, Capt. W. H. Tylden. Ibornden, Biddenden  
 Paul, James W...Knott Oak House, Ilminster  
 Paulson, F. W...Broomhill Grange, Ollerton  
 Paver, William...Peckfield, Milford Junction  
 †Paxton, Edmund...Willaston House, Bicester  
 Paxman, James...Bank Buildings, Colchester  
 Paxton, Jonas...Bicester  
 Paxton, Robert...Lower Winchenden, Aylesbury  
 Payne, George...Badwell Ash, Ixworth  
 Payne, Henry...Birdbrook, Halstead, Essex  
 †Payne, William...Willcott, Nesscliff, Salop.  
 Peacey, William...Chedglow, Tetbury  
 Peachey, Wm...Ebernoe, Petworth  
 †Peacocke, Warren...Efford, Lymington  
 Peacocke, Wilkinson...Greatford Hall, Stamford  
 Peake, John...Mullaghmore, Monaghan, Ireland  
 Pears, John, Mere, Lincoln  
 Pearson, F. Fenwick...Stours Hall, Carnforth, Lanc.  
 Pearson, J. C...Newbridge, Wolverhampton  
 Pearson, Capt. Wm...Walcote, Lutterworth  
 †Pease, J. Whitwell, M.P...Woodlands, Darlington  
 †Peck, Edmund...Plas-y-Dinas, Shrewsbury  
 Peel, Edmund...Bryn-y-Pys, Wrexham  
 Peel, George...Brookfield, Cheadle, Manchester  
 Peel, John...Middleton Hall, Tamworth  
 †Peel, Jonathan...Knowlmere Manor, Clitheroe  
 Peel, Rt. Hon. Sir R., Bt. M.P...Drayton Manor, Fazeley  
 Peel, Wm...Taliaris Pk., Llandilo, Carmarthenshire  
 Peel, William...Trenant Park, Looe, Cornwall  
 Peers, Joseph...Ruthin  
 †Peile, Rev. T. W...Laura H., Winchester Rd., N.E.  
 Pelham, F...Norfolk Farm, Windsor Park, Staines  
 †Pell, Albert, M.P...Hazelbeach, Northampton  
 †Pemberton, Rev. R. N...Church Stretton, Salop.  
 †Penn, Granville J...  
 †Pennant, P. Pennant...Brynbella, St. Asaph  
 Pennell, H. B...Dawlish  
 Pennington, Frederick...Broome Hall, Dorking  
 Pennington, Richard...Westfield House, Rugby  
 Penny, Thomas...Taunton  
 Penrice, Thomas...Kilvrough, Swansea  
 Pepper, John...3, Queen Street, Leeds  
 †Peppercorn, J. Hutchinson...Eaton Socon, St. Neot's  
 Peppercorne, H...Bradburn Park, East Malling  
 †Perales, Marquis de...Madrid

- †Perceval Chas. . . . West Haddon, Northamptonshire  
 Peren, W. B. . . . Compton, South Petherton, Somerset  
 †Perkins, Henry . . . Thriplow, Royston  
 Perkins, James . . . Manstey Farm, Penkridge  
 Perkins, Jos., jr. . . . Sibbertoft, Market Harborough  
 †Perkins, Thomas . . . Hitchin  
 Perkins, W. H. . . . Theddingworth, Rugby  
 Perkins, Walter . . . Bowling Green Ho., Southampton  
 Perkins, William . . . Minster, Ramsgate  
 †Perry, Graddon . . . Acton Pigott, Conover, Salop.  
 †Perry, Thos. A. . . . Betham Ho., Avon Dassett, Banbury  
 Perry, Sir T. Erskine, Bt. . . . West Court, Wokingham  
 Perry, W. . . . Hickmerelands, Sedgley, Dudley  
 †Perry-Watlington, J. W. . . . Moor Hall, Harlow  
 Pertwee, James . . . Boreham, Chelmsford  
 Peters, Daniel . . . 31, College Green, Bristol  
 †Peterson, A. T. T. . . . Drumdnar, Lymington  
 Peto, Lawrence J. . . . 17, Esplanade, Lowestoft  
 †Peto, Sir S. M., Bt. 9, Victoria Chamb., Victoria St.  
 Petre, Edward . . . Whitley Abbey, Coventry  
 Pettitt, E. . . . 18, St. John St., Bury St. Edmund's  
 †Pettward, R. J. . . . Firborough Hall, Stowmarket  
 Phelps, H. G. Hart, Ridley Parsonage, Wrotham  
 †Philips, Sir G. Richard, Bart. . . . Shipston-on-Stour  
 Phillips, Mark . . . Snitterfield, Stratford-on-Avon  
 Phillimore, Edward . . . Cheltenham  
 Phillimore, Rev. G. . . . Radnage, Stokenchurch, Oxon.  
 Phillips, G. T. . . . Brockton Leasowes, Newport, Salop.  
 Phillips, Henry R. . . . Willesden Paddocks, Kilburn  
 †Phillips, J. H. . . . Beadlam Grange, Nawton, York  
 Phillips, J. R. S. . . . Riffhams Lodge, Danbury  
 Phillips, Richard . . . Brackton Grange, Shifnal  
 Phillips, Thomas . . . 5, Princess Sq., Plymouth  
 Phillips, Maj.-Gen. Sir T. . . . Sen. U. S. Club, S.W.  
 Phillips, Thomas E. . . . 37, Wilton Place, S.W.  
 Phillips, Zachariah . . . Birchmoor, Woburn  
 †Phillipotts, T., jun. . . . Junior Carlton Club, Pall Mall  
 †Phipps, Charles Paul . . . Chalcot House, Westbury  
 Phipps, Filmer . . . River, Dover  
 †Phipps, J. Lewis, M.P. . . . Leighton, Westbury, Wilts.  
 †Phipps, P. . . . Collingtree Grange, Northampton  
 Phipps, Thomas . . . Bricklehampton, Pershore  
 Picken, William . . . Hilton, Newport, Salop.  
 Pickering, James . . . Whitby, Chester  
 Pickering, Leonard . . . Wilcot, Charlbury, Oxon.  
 Pickering, William . . . Poulton, Fulford, Wrexham  
 †Pickford, William . . . 148½, Fenchurch Street, E.C.  
 Pickstock, Henry . . . Baschurch, Shrewsbury  
 Pickworth, W. . . . Deeping Bank, Crowland, Lincoln  
 †Piercy, Alfred . . . Cold Harbour, Henley, Oxon.  
 Piercy, Rev. J. M. W. . . . Slawston, Market Harboro'  
 †Pierson, Jas. Alex. . . . The Gwynd, Arbroath, N. H.  
 Piggot, Jas. Algernon . . . Beckingham Hall, Witham  
 †Piggott, Geo. Grenville . . . Duddershall, Winslow  
 Pigot, Sir Robert, Bart. . . . Patshill, Wolverhampton  
 Piggot, William . . . Brigg  
 Pike, John . . . Bolland, Antony, Devonport  
 Pike, William . . . Castle Thorpe, Stony Stratford  
 Picher, Jesse . . . Cheriton Court, Hythe, Kent  
 Pilgrim, Charles H. . . . Merlewood, Virginia Water  
 Pilgrim, S. C. . . . The Outwoods, Hinckley  
 †Pilkington, Sir L. M. S., Bt. . . . Chevet Pk., Wakefield  
 Pinckard, George H. . . . Combe Court, Godalming  
 Pinder, Thomas . . . Barroby, Grantham  
 †Pinnegar, C. . . . Rockbourn, Fordingbridge, Hants.  
 Pinnell, Charles . . . Westwell, Burford, Oxon.  
 Pinney, Col. W. . . . Somerton-Erleigh, Somersetshire  
 †Pipon, Capt M. . . . Deerswood, Crawley  
 Pippet, William . . . Caughton House, Bromsgrove  
 Pitfield, A. J. . . . Eype, Symondsburly, Bridport  
 Pitfield, John . . . Symondsburly, Bridport  
 †Pitt, George . . . Chadnor Court, Dilwyn, Leominster  
 Pitt, Walter William . . . Whitechurch, Monmouth  
 Plant, Edward . . . Little Onn, Stafford  
 Plant, Henry W. C. . . . Burley Fields, Stafford  
 Platt, Henry . . . Werneth Park, Oldham, Lancashire  
 Platt, James . . . Newton, Malpas  
 Platt, John . . . Belle Vue, Wem, Salop.  
 Playfair, G. G. . . . Errol Villa, Southbrook Rd., Lee  
 Plowden, W. . . . Plowden Hall, Bishop's Castle, Salop.  
 Plumtre, Charles J. . . . Pedding House, Sandwich  
 Plumtre, J. B. . . . Goodnestone Farm, Wingham  
 Pochin, Capt. R. G., R.N. . . . Braunstone Ho., Leicester  
 †Pocock, Chas. . . .  
 Pocock, George . . . New London Road, St. Albans  
 Podmore, Robert . . . Sealand, Queen's Ferry, Flint.  
 †Pogson, Frank M. . . . Caythorpe, Grantham  
 Pogson, S. M. . . . Anwick, Sleaford, Linc.  
 Polding, James Bede . . . Burnley, Lancashire  
 Pole-Gell, H. Chandos . . . Footherley Hall, Lichfield  
 Pole, Sir Van Notten P., Bt. 59, Gloucester Pl., Hyde Pk.  
 †Pollard, Joseph . . . Highdown, Hitchin  
 †Pollen, R. H. . . . Radburn, Chippenham  
 †Pomfret, Virgil . . . Tenterden, Kent  
 Poole, Commander G., R.N. . . . Llangynider, Brecon  
 Pooler, Henry . . . Calvington, Newport, Salop.  
 Pooley, Thomas . . . Northwold, Norfolk  
 Pope, John . . . Symondsburly, Bridport, Dorset  
 Pope, William . . . The Wharf, Biggleswade  
 Porter, James . . . Corney Bury, Buntingford  
 Porter, J. T. B. . . . Lincoln  
 Porter, Major-Gen. . . . Minterne House, Dorchester  
 Porter, Thos. . . . Bawnton, Cirencester  
 Porter, Wm. . . . Hembury Fort, Honiton  
 †Portman, Hon. W. H. B., M.P. . . . Bryauston, Blandf.  
 †Portsmouth, Earl of . . . Eggesford Ho., North Devon  
 Pott, John Manger . . . Nottingham  
 Potter, T. B., M.P. . . . Buile Hill, Manchester  
 Potterton, W. H. . . . Boughton Grange, Northampton  
 Potts, Bainbriggs . . . Calverton, Notts.  
 Potts, John D. . . . 89, Goldsmith Street, Nottingham  
 Powell, Evan . . . Swan Side, Newtown, Montgomery  
 Powell, John Thomas . . . Easton, Pewsey, Wilts.  
 Powell, Richard . . . The Hall, Benson, Wallingford  
 †Powell, Rev. S. H. . . . Sharon Hall, Ripon  
 †Powell, Thos. H. . . . Drinkstone Park, Woolpit  
 †Powell, W. S. . . . Eglwys Nunyd, Taibach  
 †Power, K. Manley . . . Hill Court, Ross, Herefordshire  
 Powis, Charles . . . 60, Gracechurch Street, E.C.  
 †Poynder, T. H. A. . . . Hartham Park, Corsham  
 Poyser, Josiah T. . . . Burton-on-Trent  
 Prance, Courtney Connell . . . The Elms, Evesham  
 †Pratt, C. Alfred . . . Shenton, Nuneaton  
 Pratt, Edward . . . Caldwell, Burton-on-Trent  
 Pratt, Frederick . . . Westmeon, Petersfield  
 Pratt, Frederick . . . Greatford, Stamford

Pratt, Rich. Fred. . . . Highfield, Sedlescomb, Battle  
 †Prentice, Manning. . . . Stowmarket  
 †Preston, Capt. J. N. . . . Flaby, Gargrave-in-Craven  
 Preston, Thomas. . . . Scosthrop Ho., Bellbusk, Leeds  
 Preston, Thomas H. . . . Moreby Hall, York  
 †Pretyma, A. . . . Haughley Park, Stowmarket  
 Prevost, Lt.-Col. C. . . . Wellclose, Brockworth  
 Price, Andrew. . . . Bagley, Ellesmere  
 Price, Charles. . . . Quenington, Fairford  
 Price, Henry. . . . Undy, Chepstow  
 Price, James. . . . The Lodge, St. Miboro', Ludlow  
 †Price, Richard John Lloyd. . . . Rhiwlas, Bala  
 Price, W. . . . New House, Caerleon, Newport, Mon.  
 Price, Wm. Philip, M.P. . . . Tiberton Ct., Gloucester  
 Priday, Samuel. . . . Linton, Gloucester  
 Prideaux, Sir Edm. S., Bart. . . . Netherton, Honiton  
 Priest, Alfred. . . . Kingston-on-Thames, S.W.  
 Priestley, J. . . . Hirdrefaig, Llangifai, Isle of Anglesea  
 Priestley, S. O. . . . Trefan, Criccith, Caernarvonshire  
 Prince, John. . . . Foston Hall Farm, Derby  
 Princep, William. . . . Newton, Tamworth  
 †Pritchard, John. . . . Broseley, Salop.  
 Pritchard, Robt. . . . Llwydiarth Esgob, Bangor  
 Pritchard, Wm. . . . R. V. College, Camden Town, N.W.  
 Pritchard, W. T. . . . Angel Down Farm, Wantage  
 †Proby, Rev. W. Henry B. . . . Seaton, Axminster  
 †Proby, Hon. W. . . . Glen Art, Arklow, Ireland  
 †Probyn, Edmund. . . . Huntley, Gloucestershire  
 Proctor, H. Matthews. . . . Hill Ho., Wykeham, Spalding  
 Proctor, M. M. . . . 49, Thornhill Square, Barnsby, N.  
 Proctor, Thomas. . . . Elmdale House, Clifton, Bristol  
 †Prodgers, Herbert. . . . Kington House, Chippenham  
 Pronger, James. . . . Crawley  
 Prosser, B. . . . Offeron Farm, Hindlip, Worcester  
 †Prosser, Francis Wegg. . . . Belmont, Hereford  
 Prosser, John. . . . Honeybourne Gardens, Gloucester  
 Prosser, T. . . . Sandfield Villa, West Boldon, Durham  
 Prout, John. . . . Sawbridgeworth, Herts.  
 Pryke, John P. . . . Aldersfield Hall, Wickhambrook  
 Pryse, Colonel. . . . Peithyll, Aberystwyth  
 Pryse, J. Pugh. . . . Bwlchbychan, Llanybyther, S. Wales  
 †Pryse, Sir Pryse, Bt. . . . Gogerddan, Shrewsbury  
 Puckle, T. Broadhurst. . . . Woodcote Grove, Carshalton  
 †Pugh, David. . . . Manoravon, Llandilo, Carmarthen  
 Pugh, Robert. . . . Llayndŷ, Llayngwrl  
 †Pugh, William. . . . Coal Port, Ironbridge, Salop.  
 Pugh, William. . . . Woburn Road, Croydon, S.E.  
 †Pulleine, James. . . . Clifton Castle, Bedale  
 Pullen, Richard. . . . Shackerley House, Albrighton  
 Pulley, Joseph. . . . Lower Eaton, Herefordshire  
 Pulley, Joseph, jun. . . . Lower Eaton, Herefordshire  
 Pullin, James. . . . Wraysbury, Staines  
 Pullin, Stephen. . . . Mildridge Farm, Horton, Slough  
 Pulteney, J. G. B. . . . Lyndhurst  
 †Punnett, P. Simpson. . . . Park Hill Road, Croydon  
 Purdon, Edward. . . . Bachelor's Walk, Dublin  
 Purkis, W. . . . Horseheath, Linton, Cambridgeshire  
 Purrott, C. . . . Cliftonville, Westend, Southampton  
 Pursell, R. Rushton. . . . Oxley, Wolverhampton  
 Purser, Edward. . . . 116, Fenchurch Street, E.C.  
 Purser, Henry. . . . Willington, Bedford  
 Purser, William. . . . Cople, Bedford  
 Purton, C. C. . . . The Woodhouse, Cleobury-Mortimer

Purves, Peter. . . . The Grove, Bampton, Huntingdon  
 †Pusey, S. E. B. Bouverie. . . . Pusey Ho., Faringdon  
 Pyatt, Abraham. . . . Wilford, Nottingham  
 Pybus, John. . . . Court Farm, Magor, Chepstow  
 †Pye, Geo. . . . Widemarsh Street, Herefordshire

## Q.

Quartly, John. . . . Champion Molland, South Molton  
 Quelch, J. B. . . . Bowburn House, Ferry Hill, Durham  
 Quibell, William Oliver. . . . Newark-on-Trent  
 Quinn, P., J.P. . . . Agency, Newry, Ireland  
 Quay, Edward. . . . Goldhanger, Maldon

## R.

Racster, William. . . . Withington Court, Hereford  
 †Radcliffe, C. Lopes. . . . Derriford, Tamerton Foliot  
 Radcliffe, T. . . . Cheswell Grange, Newport, Salop.  
 Radford, H. B. . . . Stanton Ho., Burton-on-Trent  
 Radford, William. . . . Thulston, Derby  
 Radnor, Earl of. . . . Coleshill, Highworth  
 Raglan, Lord. . . . Cefntilla Ho., Usk, Monmouthshire  
 Railton, Henry. . . . Snittlegarth, Wigton  
 †Raincock, H. D. . . . Waltons, Linton, Cambs.  
 Rainforth, Edward. . . . Monkhopton, Bridgnorth  
 †Ralph, R. W. . . . Honnington Grange, Newport, Salop.  
 Ralphs, John. . . . Saughton, Chester  
 Rammell, Wm. L. . . . Sturry Court, Canterbury  
 Ramsay, G. H. . . . Newcastle-on-Tyne  
 Ramsay, Thomas. . . . Sherburn Green, Gateshead  
 Ramsbotham, J. . . . Crowborough Warren, Tunb. Wells  
 †Ramsden, John C. . . . Busbridge Hall, Godalming  
 Ramsey, John. . . . 9, Endsleigh Street, W.C.  
 Rand, William. . . . Saffron Walden  
 Randall, R. G. . . . Winfrith, Dorchester, Dorset  
 Randell, Charles. . . . Chadbury, Evesham  
 Randell, James R. . . . Chadbury, Evesham  
 Randle, Thomas. . . . Ombersley, Droitwich  
 Randolph, Lt.-Col. C. W. . . . 76, Chester Sq., S.W.  
 Ranford, C. 12, New Weston St., Bermondsey, S.E.  
 Ranken, W. B. . . . Abbot's Langley House, Herts.  
 Ransome, James Allen. . . . Ipswich  
 Ransome, J. E. . . . Bolton Hill, Ipswich  
 Ransome, R. C. . . . Ipswich  
 Ratcliff, R. . . . Standard Hill, Ninfield, Battle  
 Ratcliff, Thos. . . . Norton House, Sheepy, Atherstone  
 Ratteff, William. . . . Newmarket  
 Raven, John. . . . St. Helens, Maryport  
 Ravenshaw, James. . . . Bridleway Gate, Salop.  
 Ravensworth, Ld. . . . Ravensworth Castle, Gateshead  
 Rawes, John. . . . 29, Dicconson Street, Wigan  
 Rawlence, James. . . . Bulbridge, Wilton, Salisbury  
 †Rawlinson, Robt. . . . Sella Park, Whitehaven  
 †Rawstorne, Lawrence. . . . Hutton Hall, Preston  
 Ray, Robert Henry. . . . Waldon Hall, Saffron Walden  
 †Ray, Samuel. . . . Grove Ho., Gt. Yeldham, Halesstead  
 Rayer, Wm. Carew. . . . Volcombe Court, Wellington  
 Rayment, E. . . . 307, Vauxhall Road, Liverpool  
 †Raynbird, Hugh. . . . Church Street, Basingstoke  
 Rayner, H. . . . West View, Liverpool Road, Chester

- Rayner, Capt. W. S. N. Loanda Ho., Upper Norwood  
 Rea, Charles...Doddington, Wooler, Northumb.  
 †Read, Clare S., M.P....Honingham Thorpe, Norwich  
 †Read, Geo., jun.... Barton Hall, Brandon, Norfolk  
 Read, Henry...London Road, Beccles  
 Read, James...Salisbury  
 Reade, J...Shipton-un...Wychwood, Chipping-Norton  
 Reading, William...Ashorn, Leamington  
 Reay, Matthew...Heworth Lane, Gateshead  
 Reed, Howard... 'Herald' Office, Sydney, N. S. Wales  
 Reek, E....Horse and Dale Farm, Nuttall, Notts.  
 Rees, William...Penywaun, Glamorganshire  
 Rees, W. Treharne...Holly House, Newport, Mon.  
 Reeve, James...Snetterton Hall, Thetford  
 Reeves, J. R....Hantsland, Crawley Down, Sussex  
 Reeves, Robert...Bratton, Westbury  
 Relph, G. R. Greenhow...Beech Hill, Usk  
 Rendle, Robert... Catel Farm, Guernsey  
 Reynardson, Henry Birch... Adwell, Tetsworth  
 Reynolds, Joseph Benj....Lubbethorpe, Leicester  
 Reynolds, Osborne...Owen's College, Manchester  
 †Reynolds, Dr. William...The Cloisters, Liverpool  
 Rhodes, Arthur...Twyford House, Bishop Stortford  
 Rhodes, J. Armitage...Carlton, Pontefract  
 †Ricards, Mortimer...Bure Homage, Christchurch  
 Rice, Edward Royd...Dane Court, Wingham  
 Rich, Stiles...Cedars, Fernallt Heath, Worcester  
 †Richards, Edward Priest... Cardiff  
 †Richards, John...Llynceys, Oswestry  
 Richards, William...Belgrave, Leicester  
 †Richardson, E....Newcastle-on-Tyne  
 Richardson, Francis E...Bramshall, Uttoxeter  
 Richardson, G....Bridlington Quay, Yorkshire  
 Richardson, Henry...Cherry Hill, York  
 Richardson, John...Asgarby, Spilsby  
 †Richardson, John...The Oaks, Dalston, Carlisle  
 Richardson, Richard...Halewood, Liverpool  
 †Richardson, Robert...  
 Richmond, Francis...Salford, Manchester  
 Richmond, William...62, South John St., Liverpool  
 †Ricketts, James...Westbury-on-Severn  
 Riddell, Mj.-Gen. C.J.B. Oaklands, Chudleigh, Devon  
 Riddell, E. Cheeseburn Grange, Newcastle-on-Tyne  
 †Riddell, Henry Buchanan...The Palace, Maidstone  
 Riddell, John...St. Ninians, Wooler, Northumb.  
 †Riddell, Sir W. B., Bt...Heppele Rothbury, Morpeth  
 Rider, Thomas...Edgeboulton, Shawbury, Salop.  
 Rider, Thomas John...Kenwick, Shrewsbury  
 Rider, William...Crudgington, Wellington, Salop.  
 Ridge, T. J....Hambledon, Hordean, Hampshire  
 Ridgway, Capt. Alex....Blackanton, Totnes  
 Ridgway, John...Fairlawn, Wrotham, Kent  
 †Ridgway, J....Cauldon Pl., Shelton, Stoke-on Trent  
 Ridgway, Thomas...Lynn, Warrington  
 †Ridler, Richard H....Gatterlop, Leominster  
 Ridley, J. M....Walwick Hall, Hexham  
 †Ridley, Matthew White, M.P...Blagdon, Cramlington  
 Ridley, T. D....Chelmsford  
 Ridley, Thomas...Parkend, Hexham  
 Ridley, William Wells...The Abbey, Southam  
 Rigby, Thomas...Darnhill Farm, Winsford, Cheshire  
 Rigden, Richard Henry...Salisbury  
 Rigden, William...Hove Farm, Brighton  
 †Rigg, Joseph...Fillonghley, Coventry  
 Riley, Edmond...South Dalton, Beverley  
 Riley, Major J. E....Elm Ho., Winkfield, Windsor  
 †Riley, Luke...Meriden, Coventry  
 Ringer, John...West Harling, East Harling, Norfolk  
 †Ringrose, Robert Boyes...Swanland, Brough  
 Rising, Robert...Horsey, Great Yarmouth  
 Rising, Wm....Somerton Hall, Great Yarmouth  
 Rist, Isaac...Tattingstone, Ipswich  
 †River, John...  
 †Rivett-Carnac, Harry...Allahabad, India  
 †Rivington Harry...22, Finsbury Sq., E.C.  
 Rix, Nathaniel, jun....London Colney, St. Albans  
 Roads, J....Ashmore Farm, Addington, Winslow  
 †Roberts, A. J....Lillingstone Dayrell, Bucks.  
 Robbins, Harry...Northfield Farm, Witney  
 Roberts, Benjamin...Belle Vue, Oswestry  
 Roberts, Bennett S...Burton Hall, Wrexham  
 †Roberts, Charles G....Haslemere, Surrey  
 †Roberts, Oscar Wm....Fisherwick Park, Lichfield  
 Roberts, Edward...Berden Hall, Bishop Stortford  
 Roberts, Frederick L...Queen's Ferry, Flints.  
 Roberts, G....Wormington Grange Farm, Winchcomb  
 Roberts, John...Well House, Saltney, Chester  
 Roberts, Joseph...Southleigh, Truro  
 Roberts, Joseph...Caswell House, Witney  
 Roberts, R....The Rock, Richard's Castle, Ludlow  
 Roberts, Thomas Lloyd...Corfton Hall, Bromfield  
 Roberts, Wm. Harvey...Trehiddle, St. Austell  
 Roberts, W. Henry...Alms Hoe Bury, Hitchin  
 †Roberts, Wightwick...Trethill, Sheviok  
 Robertson, James...33, Queen Street, Whitehaven  
 Robertson, James...22, Mary Street, Dublin  
 Robey, Robert...Canwick Road, Lincoln  
 Robins, G. F....Isleham, Soham  
 Robinson, Alfred...Gas Works, Leicester  
 Robinson, Dixon...Clitheroe Castle, Clitheroe  
 †Robinson, George...Whiston, Shifnal  
 Robinson, G....Slimbridge, Stonehouse, Gloucestershire  
 Robinson, George J....Maunby, Thirsk  
 Robinson, Henry...Hough-on-the-Hill, Grantham  
 Robinson, Jas....Huggart's Farm, Brindley, Chorley  
 Robinson, James Charles...Stevington, Bedford  
 Robinson, John...Backwell House, Bristol  
 Robinson, John...Gosforth, Newcastle-on-Tyne  
 Robinson, Sir J. Stephen, Bart...16A, Park Lane, W.  
 Robinson, J. T...Lecky Palace, Asenby, Thirsk  
 †Robinson, Jos...Clifton Pastures, Newport Pagnell  
 Robinson, Rowland...Fenny Drayton, Nuneaton  
 †Robinson, S...Lynhales, Kington, Herefordshire  
 Robinson, Thomas...Nuthill, Hedon, Hull  
 Robinson, William...Bone Hill, Tamworth  
 Robinson, William...Darlington Lodge, Warrington  
 Robinson, William...Wembdon, Bridgewater  
 †Robinson, W....Madras  
 Robotham, A....Drayton Basset, Tamworth  
 Robson, James...Brackenborough, Louth  
 †Robson, John...Bymess, Rochester, Northumb.  
 Robson, Samuel, jun....Melbourne, Derbyshire  
 Robson, William...Wilton, Salisbury  
 †Rodd, F....Trebartha Hall, Launceston  
 Rodgett, Miles...Sandford, Wareham, Dorset  
 Rodwell, B. B. H....Ampton Hall, Bury St. Edm'd's

Roe, Rev. Charles...Sicclesmere, Bury St. Edmund's  
 †Roebuck, J. A., M.P....19, Ashley Place, S.W.  
 Rogers, Alfred...Plas-y-n-y-Pentre, Llangollen  
 †Rogers, Henry...Wolgarstone, Penkridge  
 Rogers, John...Chellington, Bedford  
 †Rogers, John J...Penrose, Helston  
 Rogers, T....Coxall, Brampton Bryan  
 Rogers, W. H...Goldthorne Villa, Wolverhampton  
 Rolfe, James...Bury St. Edmund's  
 †Rolls, John Allan...The Hendre, Monmouth  
 Romilly, Edward...Porthkerry, Cardiff  
 Romney, Earl of...The Mote, Maidstone  
 Rooke, John...Weldon Grange, Wansford  
 †Ronna, Antonio (C. E.)...26, Rue Jacob, Paris  
 †Rooper, George...  
 Rose, Christopher...Zeals Green, Mere, Wiltshire  
 Rose, Philip...Rayners, High Wycombe, Bucks.  
 Rosewarne, John...Nanpuska, Hayle, Cornwall  
 Rosling, Edward...Droxford, Southampton  
 †Ross, Owen, C D...Little Bookham, Leatherhead  
 †Ross, James...Hoo Park Farm, Luton  
 Ross, John...The Grove, Ravensglass, Cumberland  
 †Rosslyn, Earl...Easton Lodge, Dunmow  
 †Rothwell, R. R...Sharples Hall, Bolton, Lancashire  
 Rothwell, W. Talbot...Foxholes, Ellel, Lancaster  
 Rotton, Richard...3, Boltons, Brompton, S.W.  
 Round, D. G...Portland Ho., Edgbaston, Birmingham.  
 Rounding, Thomas...Fraithorpe, Bridlington  
 Rous, Hon. Wm. Rufus...Worstead House, Norwich  
 †Rouse-Boughton, Sir C. H., Bt. .Downton, Ludlow  
 Row, E. T...Moulds Haugh, Northumberland  
 †Rowcliffe, E. Lee...Hall Place, Cranleigh, Guildford  
 Rowell, John...Ramsey, Huntingdonshire  
 Rowland, John...Hollybank, Wootton, Woodstock  
 †Rowland, Richard...Creslow, Aylesbury  
 Rowland, Samuel...Gumsditch Hall, Northwich  
 †Rowland, Wm. Rickford...Creslow, Aylesbury  
 Rowlandson, Christopher...The College, Durham  
 Rowlandson, Samuel...The College, Durham  
 †Rowlandson, Samuel...Newton Morrell, Darlington  
 Rowley, John Geo...Rockstowes House, Dursley  
 Rowley, Hon. R. T...Rhyderddwyn Faur, Rhuddlan  
 †Royds, Albert Hudson...Falinge, Rochdale  
 †Royds, Henry...Wavertree, Liverpool  
 †Royds, Rev. John...Heysham Rectory, Lancaster  
 †Royston, Viscount, M.P...Wimpole, Cambs.  
 Ruck, Edmund...Castle Hill, Cricklade  
 Ruck, L...Pantludw, Machynlleth, North Wales  
 †Rucker, Martin D...115, Leadenhall Street, E.C.  
 Rudwick, Fred. F...Donnington, Chichester  
 Ruffe, John...Norbiton Common, S.W.  
 Rumbold, C. J. A...5, Percival Terrace, Brighton  
 Rush, T...The Chalk Farm, Babraham, Cambridge  
 Rusher, William...High Street, Banbury  
 †Russell, Lord C. J. F...Drakeloe Lodge, Woburn  
 Russell, Sir Chas., Bt...Swallowfield, Reading  
 Russell, David...Clifton Lodge, York  
 Russell, George...Manor House, Plumstead, Kent  
 Russell, John...Sutton-at-Hooe, Dartford  
 Russell, John...Ferhill House, Cheltenham  
 Russell, J...Bewbush Farm, Lower Beeding, Sussex  
 Russell, Robert...Horton Kirby, Dartford  
 †Russell, Sir W., Bt., M.P...Charlton Pk., Cheltenham

Rust, James...Alconbury House, Huntingdon  
 Rust, Wm. Holyoake...Good Easter, Chelmsford  
 Ruston, Joseph...Lincoln  
 Rutherford, Thomas...Hothfield, Ashford, Kent  
 Rutzen, Baron F. de...Slebech Hall, Haverfordwest  
 †Ryder, Hon. G. D...Westbrook, Hemel Hempsted  
 Ryder, Thomas B...57A, Church Street, Liverpool  
 Ryland, T...Gt. Lister Street Works, Birmingham

S.

Sadler, Henry...Mid-Lavant, Chichester  
 Sadler, R. Stebbing...Park Farm, Bolney, Cuckfield  
 Sadler, Thomas...Chiddingfold, Surrey  
 Sadler, Wm...Ferry Gate, Drem, N.B.  
 Sainsbury, W...Hunts Ho., W. Lavington, Devizes  
 †St. Albans, Duke of...Redbourn Hall, Brigg  
 †St. John, Hon. B. M...Oaklands, Leominster  
 †St. Leger, Col. John...Park Hill, Rotherham  
 †St. Maur, Lord Archibald...Burton, Loughborough  
 †Salkeid, Thomas...Holme Hill, Carlisle  
 Salomons, Sir David, Bt. M.P...Broom Hill, Tonbridge  
 Salt, Herbert...Thorns, Lymington, Hants.  
 Salt, Thomas...Weeping Cross, Stafford  
 Salt, Sir Titus, Bart...Crow Nest, Halifax  
 †Salt, Wm. Henry...Kirby Frith, Leicester  
 Salter, W. P...The Abbey, Thetford  
 Saltmarshe, Philip...Saltmarshe, Howden  
 †Salvin, M. C...Sarnsfield Court, Kington, Hereford  
 Samman, Wm...Middleton Park, Bicester  
 Sampson, Thomas...Moor Hall, Ninfieid, Battle  
 Samuelson, B., M.P...Britannia Iron Works, Banbury  
 Sanday, George Henry...Holme-Pierrepont, Notts.  
 †Sanday, W...Radcliffe-on-Trent  
 †Sandbach, H. R...Hafodunos, Llanrwst  
 Sanders, E. A...Stoke House, Exeter  
 Sanderson, James...111, Pall Mall East, S.W.  
 Sanderson, R. B., jun...N. Jesmond, Newc-on-Tyne  
 Sanderson, Lieut. Col. S.L.W...Eden Lacey, Penrith  
 †Sandford, G. M. W...33, Hertford Street, W.  
 †Sandford, Marks...Martin, Dover  
 Sandle, Wm...Park Hall, Gt. Bardfield, Braintree  
 Sankey, Mrs. E...Bratton Farm, Wellington, Salop.  
 Sankey, Thomas...Burntwood, Lichfield  
 Sandwich, Earl of...Hinchingsbrooke House, Hunts.  
 Sandy, Thomas G...Cliviger Street, Burnley  
 Sarson, John...Welford Place, Leicester  
 †Satterfield, Joshua...Alderley Edge, Manchester  
 †Saunders, Charles R...Nunwick Hall, Penrith  
 Saunders, G. J...Oswestry, Salop.  
 †Saunders, Thos. B...Priory, Bradford-on-Avon  
 Saunders, T. H...Watercombe, Dorchester, Dorset  
 †Saunders, William Wilson...Hillfield, Reigate  
 Savage, Gilbert Cole...Ponyknoll, Shifnal  
 Savage, Saul P...Leys Farm, Wootton-under-Edge  
 Savidge, Matthew...Lodge Farm, Chipping Norton  
 †Savignon, Don D...Mexico  
 Savory, Paul Haines...Gloucester  
 Sawyer, Charles...Heywood Lodge, Maidenhead  
 Sawyer, Henry G...Richmond Pk., Richmond, S.W.  
 Saxton, Dr. W. W...Market Drayton

- Say, R. Hall... Oakley Court, Windsor  
 Scarbrough, J. L... Coly Ho., Colyford, Axminster  
 Scarsdale, Lord... Kedleston Hall, Derby  
 Scarth, Jonathan... Shrewsbury  
 Scarth, Thos. Freshfield... Keverstone, Darlington  
 Scarth, William Thomas... Keverstone, Darlington  
 Scawin, Thomas... Durham  
 Schofield, W. Whitworth... Buckley Hall, Rochdale  
 †Schwann, F. S... Rosslyn Manse, Hampstead, N.W.  
 Scott, Col. Hon. C. Grantham... 79, Eaton Sq., S.W.  
 Scott, Jas. Winter... Rotherfield Park, Alton, Hants.  
 Scott, Jonathan... Little Crosthwaite, Keswick  
 Scott, Joseph... Colney Hall, Norwich  
 Scott, Joseph... 4, Osborn Ter., Newcastle-on-Tyne  
 Scott, Lawrence... Moor End, Ruddington  
 Scott, Louis G... 79, Eaton Square, S.W.  
 Scott, Thomas... Gt. Barton, Bury St. Edmund's  
 Scott, T. C... 19, King's Arms Yard, Moorgate St.  
 Scott, T. E... Liverpool Rd., Kingston Hill, S.W.  
 Scott, T. R... Porchester Farm, Fareham, Hants.  
 Scott, William... Normanton Turville, Hinckley  
 Scott, William, C. E... Towyn  
 †Scott, Wm. C... Thorpe, Chertsey  
 Scragg, Thomas... Calveley, Tarporely  
 †Scragg, William... Great Clacton, Colchester  
 †Scrutton, D. R... Ogwell, Newton Abbott  
 †Scriven, E... Wormleighton Hill, Leamington  
 Scriven, George... Castle Ashby, Northampton  
 Scudamore, John... Pengethley Court, Ross  
 Scudamore, Lt.-Col... Kentchurch Court, Hereford  
 Seager, James Lys... Carroun Ho., S. Lambeth, S.E.  
 Seal, Charles Wm... Herriard Grange, Basingstoke  
 Searson, R... Cranmore Lodge, Market Deeping  
 Seawell, Thos. Aug... Marelands, Farnham, Surrey  
 †Sebright, Sir J. G. S., Bt... Beechwood, Dunstable  
 †Sedgwick, Professor... Trinity College, Cambridge  
 Sedgwick, A. O... Watford, Herts.  
 †Seels, Henry John... Wainfleet Hall, Lincolnshire  
 Selmes, James... Tufton Pl., Northiam, Staplehurst  
 Senhouse, Capt. Wm... Ashby St. Ledgers, Rugby  
 Senior, James... The Pennicroft, Stafford  
 Seppings, T. J... Wormegay Grange, King's Lynn  
 †Severn, J. P... Penybont, Radnorshire  
 Sewell, Daniel... Beaumont Hall, Colchester  
 †Sexton, G. Mumford... Wherestead Hall, Ipswich  
 †Seymour, Rev. Sir J. H. C... Berkhamstead  
 Seymour, Richard A... Kinwarton Rectory, Alcester  
 †Shackel, George... Erleigh Court, Reading  
 Shackle, Thomas... Hayes, Uxbridge  
 Shaftesbury, Earl of... St. Giles', Cranbourne  
 Shafto, T. D... Cheveny House, Hunton, Maidstone  
 Shakeshaft, Thomas... Ravenstone, Olney, Bucks.  
 Shakespears, John... Copson Magna, Hinckley  
 Shann, Charles... Inholes, Tadcaster  
 Sharman, S... Little Crosby, Liverpool  
 †Sharman, Warren... Melton Mowbray  
 Sharp Granville... Cardew Lodge, Carlisle  
 Sharp, Isaac... Middlesborough-on-Tees  
 Sharp, William... Shottesbrook, Maidenhead  
 Sharpe, William... Mavis Enderby, Spilsby  
 Sharpe, W. Barling... Baker's Cross, Cranbrook, Kent  
 †Sharpley, Coates... Kelstone Hall, Louth  
 †Sharpley, Henry... Achthorpe, Louth, Lincolnshire  
 †Sharpley, Isaac... Boswell House, Louth  
 Shaw, Chas. H... Woodbine Cottage, Hackney, N.E.  
 Shaw, Geo., M. D... Leicester  
 †Shaw, Rev. G. E. F... Edgeworth, Cirencester  
 Shaw, H., Cpt. T. B. Wimborne, Kidderminster  
 †Shaw, John... Beddington Lodge, Croydon, S.  
 †Shawe, R. F... Lotherton Hall, South Milford  
 Sheffield, Earl of... Sheffield Park, Uckfield  
 Sheffield, Sir R., Bt... Normanby, Brigg  
 †Sheild, W. H... Lameter Valley, Narberth  
 †Sheldon, H. J... Brailes House, Shipston-on-Strour  
 †Sheldon, Jonathan... Eynsham, Oxford  
 Sheldon, Jonathan, jun... Eynsham, Oxford  
 Sheldon, Thomas... Osney Mill, Oxford  
 Shellabear, Samuel... Holkhams, Wells, Norfolk  
 Shephard, J... Carlton Villa, Torpoint, Devonport  
 Shepherd, E. H... Bovington Farm, Wool, Wareham  
 Shepherd, William... Eaton, Chester  
 Shepperson, Thomas... Lenton, Notts.  
 †Sherard, Lord Philip C... Glatton, Stilton, Hants.  
 Sheraton, William... Broom House, Ellesmere  
 †Sherborn, Francis... Bedfont, Hounslow, W.  
 Sherbrooke, H. Porter... Oxton, Southwell, Notts.  
 Sheridan, R. B... Frampton Court, Dorchester  
 Sheriff, Alexander C., M.P... Worcester  
 Shield, J., jun... Casington Grange, Belford, Northum.  
 †Shillingford, George Wm... Eynsham, Oxford  
 Shingler, J. H... Birch Hall, Ellesmere  
 Shipman, Robert M... Beedbury, Stockport  
 Shipman, Thomas... Croxton Lodge, Grantham  
 Shipperdson, Rev. E. H... Hermitage, Chester-le-St.  
 Shirley, Thos... Pond Cross Farm, Newport, Essex  
 †Short, Algernon L. H... Edlington, Horncastle  
 †Shrewsbury and Talbot, Earl of... Ingestre, Stafford  
 †Shrubb, John Lane... Rodlease, Lymington  
 Shuker, William... Calveley, Tarporely  
 †Shuter, James... Crookham, Newbury  
 †Shuttleworth, Alfred... Heighingham Hall, Lincoln  
 †Shuttleworth, Joseph... Hartsholme Hall, Lincoln  
 Shuttleworth, Robert... Prestwich, Manchester  
 Sibley, Robert... Annable's Farm, Luton  
 Siddorn, Henry... Rushton, Tarporely  
 Sikes, John... Sudbury, Suffolk  
 Silcock, Richard... Thornton Hall, Poulton-le-Fylde  
 †Sills, William... Casthorpe, Grantham  
 Silvester, F. R... Hedges Farm, St. Albans  
 †Simes, Nathaniel P... Stood Park, Horsham  
 Simon, James... Greenfield, Holywell, Flintshire  
 Simon, Thomas... Fernhill, Market Drayton  
 Simonds, Henry Adolphus... Reading Iron Works  
 †Simonds, J. Cabourne... Fishtoft, Boston  
 †Simonds, Thomas... 41, West Smithfield, E.C.  
 Simonds, W. B., M.P... Abbott's Barton, Winchester  
 Simpkin, Benjamin... Fotheringhay, Oundle  
 †Simpkin, Joseph... Narborough, Leicester  
 Simpkin, Thomas H... Hoby, Leicestershire  
 Simpson, A... Westmoreland Mills, Chiswell St., E.C.  
 Simpson, George... Wray Park, Reigate  
 Simpson, H. Bridgman... Babworth, Retford, Notts.  
 Simpson, John... Pyle Hotel, Bridgend  
 Simpson, John... Potterspur, Stoney Stratford  
 Simpson, John Thomas... Boughton, Ollerston  
 Simpson, Joseph... Spofforth Park, Weatherby



†Simpson, Pinder...34, Saville Row, W.  
 Simpson, R....Haggerston, Beal, Northumberland  
 Simpson, S....33, South King Street, Manchester  
 Sims, W. Dyllwyn...Ipswich  
 Sinclair, John...Glenurquhach, Inverness  
 Sing, Henry...Swancote, Bridgnorth  
 Sing, William...Newton, Bridgnorth  
 Singleton, Edward...Hullaton Grange, Uppingham  
 Singleton, John...Poulton-le-Fyde, Lancashire  
 †Sisson, Robert James...Talarly, St. Asaph  
 Sitwell, Rev. H. W....Stainsby House, Derby  
 Sitwell, Robert Sacheverill...Merley, Derby  
 Skead, J...Calder Farm, Calder Bridge, Whitehaven  
 †Skelmersdale, Lord...Lathom House, Ormskirk  
 †Skelton, E. Dunkley...Sutton Bridge, Lincolnshire  
 Skillicorn, William Nash, Cheltenham  
 Skipworth, G. B....Moorton House, Caistor  
 Skirving, William...15, Queen Square, Liverpool  
 Skrine, Henry Duncan...Warleigh Manor, Bath  
 †Slade, A. F....Kemmal House, Chiselhurst  
 †Sladen, Charles...Geolong, Victoria, Australia  
 Sladen, Douglas B....2, King's Arms Yard, E.C.  
 Sladen, Joseph...Hartsbourne Manor, Watford  
 Sladen, Captain J. B...Donnington, Newport, Salop.  
 Sladen, St. Barbe...14, Parliament Street, S.W.  
 Slaney, John...Purville Ho., Wellington, Salop.  
 Slater, Cyrus...Dunkirk, Holmes Chapel  
 Slater, Martin...Cheveley Hall, Newmarket  
 Slator, Thomas...Market Place, Boston  
 Slee, Henry W....Leicester  
 Slye, Wm. Walter...Beaumont Castle, Lancaster  
 Smallbones, G. B....Sternickel & Lentenis, Vienna  
 Smart, William Lynn...Linden, Woburn  
 Smedley, C. E. B....Shottle House, Belper  
 Smijth, Sir William Bowyer, Bart....  
 †Smith, Abel, M.P....Woodhall Park, Hertford  
 Smith, Alexander M....Kent Street, Liverpool  
 †Smith, Augustus...Tresco Abbey, Isles of Scilly  
 Smith, Charles...Kent Street, Liverpool  
 †Smith Charles...Dunchurch Hall, Rugby  
 †Smith, Sir Chas. C. W., Bt....Suttons, Romford, E.  
 †Smith, C. R....Filkin's Hall, Lechlade  
 †Smith, Edward...Radcliffe-on-Trent  
 †Smith, Edward James...14, Whitehall Place, S.W.  
 Smith, F. D. Lea...Halesowen Grange, Halesowen  
 †Smith, George...The Luham, Penrith  
 Smith, George...Ailston House, Stratford-on-Avon  
 †Smith, George P....Crooks, Coldstream, N. B.  
 Smith, George Robert...Selsdon Park, Croydon  
 †Smith, H...The Grove, Cropwell, Bingham, Notts.  
 Smith, H...New House, Sutton Maddock, Shifnal  
 Smith, Henry...Eshe Hall, Durham  
 Smith, Henry...Brierly Hill  
 Smith, H...Eaton Constantine, Wellington, Salop.  
 Smith, Henry...Harnage, Shrewsbury  
 Smith, Henry Abel...Welford, Nottingham  
 Smith, H. F...Lamworth House, Sutton, Yorkshire  
 Smith, Henry Trefusis...Devonport  
 Smith, Henry William...Evesham  
 Smith, James...Little Moyle, Carlow, Ireland  
 Smith, J. A...Bradford Peverell, Dorchester  
 †Smith, J. Hesletine...58, Lincoln's Inn Fields, W.C.  
 †Smith, J. Metcalf...Leeds

†Smith, John...  
 Smith, John...The Abbey, Romsey, Hants.  
 Smith, John...Deeping High Bank, Crowland  
 Smith John F...Glemsford, Sudbury  
 Smith, John Phillips...Lower Wick, Worcester  
 Smith, J. T...Beauchamp Grange, Kibworth  
 Smith, Joseph...Cable Street, Lancaster  
 Smith, Joseph...Henley-in-Arden  
 Smith, Joseph Lambourne...Ledbury  
 Smith, Martin T...13, Upper Belgrave Street, S.W.  
 †Smith, Percy L...Gt. Peating Lodge, Lutterworth  
 Smith, Ralph...Lenchwick, Evesham  
 Smith, Richard Booth...Huxley Farm, Edmonton, N.  
 Smith, Richard S...Durrington, Salisbury  
 †Smith, Robert...Guldings, Hertford  
 Smith, Robert...Harford House, Chew Magna, Bristol  
 †Smith, Robert Barclay...Tynewydd, Bangor  
 †Smith, R. Clifford...Swinton, Manchester  
 Smith, Robert Thursfield...Whitchurch, Salop.  
 Smith, Samuel...Somerton, Deddington, Oxon.  
 Smith, Thomas...Mollington Farm, Chester  
 Smith, Thomas...Stableford, Bridgnorth  
 †Smith, Thomas Carrington...Admaston, Rugeley  
 Smith, Tysoe...Hinckwick Farm, Stow-on-the-Wold  
 †Smith, Sir Wm., Bt....  
 Smith, William...Chimhams, Farningham, Dartford  
 †Smith William...Winchcomb, Gloucestershire  
 †Smith, William...Bibury, Fairford  
 Smith, William...Goole Grange, Goole, Yorkshire  
 Smith, William...Kettering  
 Smith, William...Littlehales, Newport, Salop.  
 Smith, William...High Hoopern, Exeter  
 †Smith, W...Sandon House, Clifton Down, Bristol  
 †Smith, W. B...Stoneleigh Villa, Leamington  
 Smithell, R. Hudson...Hengrove House, Margate  
 Smithers, William...Quarrie, Bletchingley, Surrey  
 Smithin, Benjamin...Dumbleton, Evesham  
 Smithin, Joseph...Wadborough, Kempsey, Worcester.  
 Smithson, Geo...63, Wellington Road, Birmingham  
 Smyth, Sir C. F., Bt...Acton Burnell, Shrewsbury  
 Smyth, James...Peasenhall, Witham  
 †Smyth, John George...Heath Hall, Wakefield  
 Smyth, William...Little Houghton, Northampton  
 Smyth, Rev. William...Elkington Hall, Louth  
 †Smythies, Carleton...  
 †Smythies, George...Leintwardine, Salop.  
 Sneezum, Thomas...Preston, Middlesex, N.W.  
 †Snell, John F...Witham House, Essex  
 Snewing, Charles...Holywell Farm, Watford  
 Snow, Cyprian...Manor Farm, Dunston, Sleaford  
 Snow, James M...Metheringham, Sleaford  
 †Snow, Thomas Owen...Lack Hall, Chester  
 †Snowball, F. J...Seaton Burn House, Cramlington  
 Snowball, William...Monkton, Gateshead  
 Soames, D. W...Harrow Weald, Stanmore, N.W.  
 Sollom, Francis...Pennfields, Wolverhampton  
 Solly, George Bushell...Monkton Court, Ramsgate  
 Somerset, John...Milton, Pewsey, Wilts.  
 †Somerville, J. C...Dinder Ho., Wells, Somerset.  
 Souley, W...Kirby Moorside, Yorkshire  
 †Southall, Thomas, Worcester  
 Southgate, Walter...Ipswich  
 Southwell, F. C...Albion Iron Works, Rugeley

- Sowerby, Francis... Aylesby, Great Grimsby  
 Spanton, Robert... Swaffham  
 Spark, William... Shilton House, Coventry  
 †Sparks, William... Crewkerne  
 Speakman, Thomas... Doddington Park, Nantwich  
 Spearing, J. B. Kelburne Lodge, Hurst, Wokingham  
 †Spedding, John J... Greta Bank, Keswick  
 Spence, Charles... Little Holt Farm, Bridgnorth  
 Spence, John F... Chirton Cottage, North Shields  
 Spencer, Earl, K.G... Althorp, Northampton  
 †Spencer, E... Bircher, Leominster  
 Spencer, Francis... Claybrooke, Lutterworth  
 Spencer, John... Whorlton Hall, Newc.-on-Tyne  
 Spencer, John... Woodland, Calne  
 Spencer, John... Villiers Hill, Kenilworth  
 Spencer, John, 69, King William Street, E.C.  
 †Spencer, J. W., jun... Whorlton Hall, Newcastle-on-Tyne  
 †Spencer, M... Lemington Hall, Blaydon-on-Tyne  
 †Spencer, Thomas... Ryton, Newcastle-on-Tyne  
 †Spicer, J. W. Gooch... Spye Park, Chippenham  
 Spiers, R. James... 14, St. Giles Street, Oxford  
 †Sponner, William Charles... Southampton  
 Spraggon, Benjamin... Nafferton, Stockfield-on-Tyne  
 †Spurr, Anthony... Dowlands, Lyme, Dorset.  
 Spurr, George... Boston, Lincolnshire  
 Squarey, Elias P... Odstock, Salisbury  
 Squire, Edward Frederick... Cross Hall, St. Neot's  
 Squire, William... 5, Coleman Street, E.C.  
 Stable, Robert Scott... The Park, Wanstead, N.E.  
 †Stables, W. A... Cawdor Castle, Nairnshire, N. B.  
 Stafford, Thomas... Marnham, Newark, Notts.  
 Stainton, John... Dalby, Spilsby  
 †Stallard, John... Worcester  
 Stallard, Josiah... The Blanquettes, Worcester  
 Stallard, William... Aylestone Hill, Hereford  
 Stamford & Warrington, Earl of... Enville, Stourbridge  
 Stamper, Thos... Highfield Ho., Oswaldkirk, York  
 †Standish, W. Standish... Duxbury Park, Chorley  
 Stane, John Bramston... Forest Hall, Ongar  
 Stanford, Walter... Parham, Storrington, Sussex  
 Stanford, W... Charlton Court Farm, Steyning  
 †Stanhope, J. B... Revesby Abbey, Boston  
 Stanier, J. E... Uppington, Wellington, Salop.  
 †Staniforth, Rev. Thos... Storr's Hall, Windermere  
 Stanley, Edward... 14, Grosvenor Square, W.  
 Stanley, E... The Height, Grange, Lancashire  
 Stanley, Henry... Upton, Shifnal  
 Stanley, H... Yieldfield Hall, Bloxwich, Walsall  
 †Stanley, William... Ponsoby Hall, Whitehaven  
 Stanley, W. H. S., jun... 21, Curzon St., May Fair, W.  
 Stansfeld, W. R. C... Frimley Pk., Farnboro' Station  
 †Stanton, Rev. J. J... Lovington Vicarage, Bath  
 †Staples-Browne, F. J...  
 †Stapylon. Major H. M... Myton Hall, Borobridge  
 Stark, Michael J... Duke's Palace Bridge, Norwich  
 Stark, W. P. Wilkinson... 2, Engadina, Torquay  
 †Starkey, J. Bayntun... Spye Park, Chippenham  
 Starkey, Major L. C... Wrenbury Hall, Nantwich  
 Statter, John... New Brighton, Chester  
 Statter, Thos... Stand Hall, Whitefield, Manchester  
 Statter, T., jun... Stand Hall, Whitefield  
 Staveley, John... Dotterill Park, Driffield  
 Staveley, Simpson... Tibthorpe Manor, Driffield  
 Stawell, Col. Alcock... Kilbrittain, Bandon, Cork  
 Stearn, Samuel G... Brandeston, Wickham Market  
 Stebbing, Henry... Stow Bedon Hall, Attleboro'  
 †Stedman, James... Lucton, Leominster  
 Stedman, Wm... Bucknell House, Bucknell, Salop.  
 Steedman, E. B... High Ercall, Wellington, Salop.  
 Steedman, George... Hall Green, Birmingham  
 Steere, Lee, M.P... Jayes Park, Dorking, Surrey  
 Stenning, Edward... Stratton House, Godstone  
 Stenning, William... Halsford, East Grinstead  
 Stephens, Rev. F. T... St. Mawgan, Cornwall  
 Stephens, George... Fladbury, Pershore  
 †Stephens, J... 7, Westbourne Cres., Hyde Park Gar.  
 †Stephens, Robert... 13, Paragon, Bath  
 Stephenson, Christopher... Woburn, Bedfordshire  
 Stephenson, Hugh... Throckley Ho., Newc.-on-Tyne  
 †Stevens, Alfred Henry... Farnham, Surrey  
 †Stevens, J. Curzon Moore... Winscott, Torrington  
 †Stevens, Rev. T... Bradfield Rectory, Reading  
 Stevens, William Carr... 33, Mark Lane, E.C.  
 †Stevenson, Capt. C. B... Hennor House, Leominster  
 Steward, A. Benn... Newton Manor, Carnforth, Lanc.  
 Steward, Wm... Lambton, Fence Houses  
 †Stewart, Alex. J. R... Ards House, Donegal, Ireland  
 Stewart, Arthur... Barton House, Gloucester  
 †Stewart, M. J... Ardwell House, Stranraer, N. B.  
 †Stewart, W. M... Culhoun House, Stranraer  
 Stickney, William... Ridgmont, Burstwick, Hull  
 Stilgoe, N... Manor Farm, Adderbury, Banbury  
 †Stilgoe, Z. W... Adderbury Grounds, Banbury  
 Still, Henry... Chelsham, Croydon, S.  
 †Stilwell, Arthur F... Shepherdswell, Dover  
 †Stilwell, J. J. R... Killinghurst, Haslemere  
 †Stirling, John... Bridekirk, Cockermonth  
 †Stirling-Maxwell, Sir W., Bt., Keir House, Perthsh.  
 Stirling, Sir W., Bt... Burrs Wood, Tunbridge Wells  
 Stocker, J. P... 93, Oxford Terrace, W.  
 Stocks, Charles... Cheadle, Manchester  
 Stone, Edward B... Chipchase Mill, Wark, Northum.  
 Stone, J. J... Ashton Vil., Upper Lewisham Rd., S.E.  
 Stone, J. Chamberlain... Rowleyfields, Leicester  
 Stone, John S... Newport, Monmouthshire  
 Stone, N. Chamberlain... Ayleston Hall, Leicester  
 †Stoneham, Frederick... Crayford  
 Stopford, W. Bruce... Drayton House, Thrapstone  
 Storer, C., M. D... Lowdham Grange, Nottingham  
 Storer, Rev. John... Hellidon, Daventry  
 Storey, George... Braunshawe House, Burnley  
 Storey, Joseph... Crosslands, Lancaster  
 †Storror, Robert... Grittleton, Chippenham  
 Story, J. B... Lockington Hall, Derby  
 Stott, Miss Susannah G... Eccleshill Hall, Leeds  
 Stowell, William Stow, jun... Darlington  
 †Stowey, Augustus... Kenbury House, Exeter  
 †Stracey, Sir H. J., Bt., M.P... Rackheath Hall, Norwich  
 †Strafford, Earl of... 5, St. James's Square  
 Strafford, Henry... 13, Euston Square, N.W.  
 Straker, Henry... Riding Mill, Northumberland  
 Strangway, Henry Bull... Shapwick, Bath  
 †Stratford, H. S... Thorpe, Market Harborough  
 †Strathallan, Visc... Strathallan Castle, Auchterarder  
 Straton, Rev. G. W... Aylestone, Leicester

Stratton, George...Spinnymoor House, Durham  
 †Stratton, James...Chilcombe, Winchester  
 Stratton, Joseph...Upton Lower Farm, Burford  
 Stratton, Rev. J. G...Ditton Rectory, Maidstone  
 †Stratton, J. L...Turveston Ho., Brackley, Northam.  
 †Stratton, R., jun...The Duffryn, Newport, Mon.  
 Stratton, William...Kingston Deverill, Warminster  
 Street, Frederic...Harrowden, Bedford  
 Strelly, Richard Clayton...Oakerthorpe, Alfreton  
 †Strickland, Chas. William...Boynon, Bridlington  
 Strickland, G...Low Abbey, Kirkby Thore, Penrith  
 Strickland, Walter...Cokethorpe Park, Witney  
 †Strode, Major G.S.Newnham Pk., Plympton, Devon  
 Strongitharme, G...Rushall, Wallsall, Staffs.  
 †Strutt, The Hon. Arthur...Duffield, Derby  
 †Strutt, The Hon. Frederick...Kingston, Derby  
 †Stuart, J. W...Raynham Hall, Brandon, Norfolk  
 †Stuart, Lieut.-Col. Wm...Kempston, Bedford  
 Stubbs, Chas...Preston Hill, Penkridge  
 Stubbs, Samuel...Bridgford, Stafford  
 Stubbs, John...Burston House, Stone  
 Stubbs, Richard...Stone, Staffs.  
 Stubbs, Thomas...Tedesley Coppice, Penkridge  
 Stubbs, William...Rickerscote, Stafford  
 Stuckey, H...Cothelstone, Lydeard, Taunton  
 †Stunt, W. C...Brogdale, Ospringe, Faversham  
 Sturge, Charles...Crundels Farm, Bewdley  
 Sturgeon, Chas...South Ockenden Hall, Romford, E  
 Sturgeon, Joseph...Norton Hall, Woolpit  
 Sturgess, Thomas...Penshurst, Tunbridge  
 Start, Henry Gerard, M.P...Critchill, Wimborne  
 Stutter, J...Oak Lodge, Queen's Road, Clapham, S.  
 Suffolk, Earl of...Charlton, Malmesbury  
 Suffield, Lord...Guntton Park, Norwich  
 Sumner, Rev. C. V. H...The Paddock, Swaffham  
 Summer, R...Cranmere House, Worfield, Bridgnorth  
 Summerfield, Joseph...Green Barn, Lichfield  
 Summers, Thomas, jun...Cowgreaves, Shifnal  
 Surman, J. Surman...Swindon Hall, Cheltenham  
 †Surtees, Henry Edward...Dane End, Ware  
 †Surtees, V. C. V., M.P...Newcastle-on-Tyne  
 †Surtees, Wm. Edward...Tainfield Ho., Taunton  
 Sutcliffe, Rev. Thomas...Royds Ho., Heptonstall  
 Suttle, W. Benoni...Whalley Grange, Manchester  
 †Sutton, Martin Hope...Cintra Lodge, Reading  
 †Sverdrup, Thorwald...Fredericksvaern, Norway  
 Swallow, W...Chapel Farm, Barton-on-Humber  
 Swan, Joseph...5, Carlton Place, Newc.-on-Tyne  
 Swan, Mark...Lesbury, Bilton  
 Swan, W. R...Wall's End, Newcastle-on-Tyne  
 Swann, John...Bedlington, Morpeth  
 Swann, William...Bedlington, Morpeth  
 †Swanwick, R...R. A. College Farm, Cirencester  
 Sweeten, Benjamin T...Ash Grove, Penrith  
 †Sweet, John Beaumont...  
 Swift, George...Hanchurch, Newcastle, Staffs.  
 †Swinburne, Sir J., Bt...Capheaton, Newc.-on-T.  
 Swinburne, T. W...Cordean Hall, Winchcombe  
 Swindley, Major J. E...Herr Lackenden House,  
 Woodchurch, Kent  
 Swinford, John...Sarre, Margate  
 Swinnerton, Robert...Weddington, Nuneaton  
 †Swinnerton, W. W...Styvechall Grange, Coventry

Sworder, H...Hallingbury Hall, Bishop Stortford  
 Sworder, J...West Mill Bury, Buntingford, Herts.  
 Sworder, William...Tawney Hall, Romford, E.  
 Sydney, Viscount...3, Cleveland Square, S.W.  
 †Sykes, Edmund H...Edgeley, Stockport  
 Sykes, John...Croes Howell, Wrexham  
 Symonds, Frederick...Oxford  
 Symonds, Horatio P...Oxford  
 †Symonds, Thomas Powell, jun...Pengethley, Ross  
 Symondson, G...Upshire Hall, Waltham Abbey, N.

T.

†Taber, John...Herne Hill, S.  
 Tabley, Lord de...Tabley House, Knutsford  
 †Tachard, Albert...97, Rue de Lille, Paris  
 †Taily, W. Ward...Skeffington Hall, Leicester  
 Tait, Henry...Shaw Farm, Windsor  
 Talbot, C. R. M., M.P...Margarn, Glamorganshire  
 †Talbot, H...Stanningfield Hall, Bury St. Edmund's  
 Talbot, John...Lane House, Burton, Westmoreland  
 Talbot, W. H...Hartwood Hall, Chorley, Lancashire  
 Talbot, Col. Hon. W. P...Oakington, Harrow  
 Tallant, Francis...Eas-ebourne Priory, Midhurst  
 †Tangye, Richard...Cornwall Works, Birmingham  
 Tanner, Henry...2, Claremont Pl., Clifton, Bristol  
 Tanner, J. M...Kings Nympton Pk., Chumleigh  
 Tanner, Richard...Frodesley, Donington, Salop.  
 Tanton, E...Hill Farm, Torrington, Devon  
 Tasker, William...Waterloo Iron Works, Andover  
 Tate, John...Barnhill, Acklington, Northumberland  
 Tate, W. J...Dunham Massey, Altrincham  
 Tattersall, Edm...Albert Gate, Hyde Park, W.  
 Tattersall, William...St. Anthony's, Milnthorpe  
 Tatton, T. W...Wythenshawe Hall, Manchester  
 Taunton, George...Oxford  
 Taunton, William...Redlynch, Salisbury  
 Tawney, A. R...Banbury  
 Taylor, Rowland...Colchester  
 Taylor, Sir Charles, Bt...Forest Lodge, Liphook  
 †Taylor, Chas. H...Cornhill, Coldstream, N.B.  
 Taylor, Edward...Whitton, Leintwardine  
 Taylor, Francis...Church Street, Romsey, Hants.  
 Taylor, Francis Howard...Burntwood Hall, Barnsley  
 Taylor, George...Dudley, Staffordshire  
 †Taylor, G. E...Langthorpe House, Boroughbridge  
 Taylor, Henry...Elmbridge Green, Droitwich  
 Taylor, Henry T...Holmer House, Hereford  
 Taylor, Henry...Pattingham, Wolverhampton  
 †Taylor, Herbert M...Shalden Manor, Alton, Hants.  
 Taylor, James...Farmer's Club, Salisbury Square  
 Taylor, James W...38, Chester Ter., Regent's Pk.  
 Taylor, John...Belgrave Gate, Leicester  
 †Taylor, John...Burnfoot House, Wigton, Cumberland  
 Taylor, John...Aston Clinton, Tring  
 Taylor, J., jun...  
 †Taylor, Richard...Langdon Court, Plymouth  
 Taylor, R. P...Adelaide Pl., London Bridge, E.C.  
 †Taylor, Sam...Eccleston Hall, Prescot, Lancashire  
 †Taylor, Simon W...Erlestone Park, Devizes  
 Taylor, Thomas...Hopton, Wirksworth

- Taylor, Thomas...Ashton Rowant, Tetsworth  
 †Taylor, Thomas...Shipton-on-Cherwell, Oxford  
 Taylor, T. Loombe...Starston, Harleston, Norfolk  
 Taylor, Thomas S...Leicester Frith, Leicester  
 Taylor, William...Glenley, Westham, Sussex  
 Taylor, Wm...Wickham Court Farm, Beckenham  
 Taylor, Wm...Showle Court, Stoke Edith, Hereford  
 Taylor, William...37, West Street, Leicester  
 Taylor, William...Thinghill Court, Hereford  
 Taylor, William...Barnhurst, Tettenhall, Staffs.  
 Taylor, Wm. Hy...High Hatton, Shawbury, Salop.  
 Tayton, William...Syderstone, Fakenham  
 Teece, Richard...Weston Villa, Baschurch, Salop.  
 †Teleki, Countess Harley...Eywood, Kington  
 †Tempest, C. Henry...Broomlands, Nantwich  
 Tempest, Colonel...Tong Hall, Leeds  
 †Templemore, Lord...Dunnoy Pk., Wexford, Ireland  
 Templeton, A...Glanhenwey, Glasbury, Hereford  
 †Templetown, Visct...Castle Upton, Templepatrick  
 Tench, John...Ludlow  
 Tennant, J...Abbey Field Farm, Newstead, Notts.  
 Tennant, Joseph Mason...Headingley, Leeds  
 Tennant, John Robert...Kildwick Hall, Leeds  
 †Tennant, Robert...Scarcroft Lodge, Leeds  
 Tennant, Thomas...Blenheim Terrace, Leeds  
 Teverson, Henry...High Garrett, Braintree  
 Thackeray, Capt...Junior United Serv. Club, S.W.  
 Thackwell, John Cam...Dymock, Gloucestershire  
 †Thenard, Baron...6, Place St. Sulpice, Paris  
 †Thew, Edward...Lesbury House, Alnwick  
 Thistlethwayte, Thomas...Southwick Pk., Fareham  
 Thomas, Edward...The Cross, Oswestry  
 †Thomas, G. T...Ermatingen, Thurgovie, Switz.  
 Thomas, John...Bletsoe, Bedford  
 Thomas, J. H...Starling Park, Carmarthen  
 Thomas, L. H...Caerfynnion, Talsarna, Caernarvon  
 Thomas, Richard...The Buildings, Baschurch  
 Thomas, Thomas...St. Hilary, Cowbridge  
 Thomas, Thomas...Treprenal, Oswestry  
 Thomas, W...Penn Fields, Wolverhampton  
 †Thomas, Rev. W. J...Llan Thomas, Hay, Herefordsh.  
 Thompson, Alexander...Kirknewton, Wooler  
 †Thompson, Andrew...Berwick-on-Tweed  
 †Thompson, Anthony...Cross, Whitehaven  
 Thompson, E. C...Woodland, Beaconsfield, Bucks.  
 Thompson, E. J...Timperley, Altrincham  
 Thompson, F...Drakelowe, Burton-on-Trent  
 Thompson, Maj. F. W...36, Nottingham Pl., Reg. Pk.  
 Thompson, Henry...Organsdale, Kelsall, Chester  
 Thompson, James...Bishop Auckland, Durham  
 Thompson, James...Castle Meadows, Kendal  
 †Thompson, John...Badminton, Chippenham  
 Thompson, J. W...1, Claremont Bank, Shrewsbury  
 Thompson, Leonard...Sheriff Hutton Park, York  
 Thompson, Matt...Kirkby Stephen, Westmoreland  
 †Thompson, Robert...Inglewood Bank, Penrith  
 Thompson, T. C...Milton Hall, Brampton, Cumbd.  
 Thompson, T. C...Ashdown Park, East Grinstead  
 †Thompson, W., jun...Thorpe, Colchester  
 †Thompson, William...Weymouth  
 Thompson, Rev. William...Eshe Land, Durham  
 †Thompson, W...Moresdale Hall, Kendal  
 Thompson, William...Walton, Stone, Staffordshire  
 Thomson, Guy...Old Bank, Oxford  
 †Thomson, John...Baldon House, Oxford  
 Thomson, John...Kings Newton, Derby  
 Thomson, Maj. R. T...Broomford Manor, Exbourne  
 Thomson, Wm. C...Dilston Haugh, Corbridge  
 Thorn Charles...St. Giles Gate, Norwich  
 †Thornes, Joseph...Green House, Ossett, Wakefield  
 Thornhill, George...Diddington, Huntingdon  
 †Thornhill, T...Riddlesworth Hall, Thetford  
 Thornhill, T., jun...Packenham, Bury St. Edmund's  
 Thornhill, Wm. Capel Clarke...Bunting's, Uxbridge  
 †Thornhill, William P...Stanton Hall, Bakewell  
 Thornton, Edward...Little Pitchford, Shrewsbury  
 Thornton, Harry...Goldington Bury, Bedford  
 †Thornton, John...15, Langham Place, W.  
 †Thornton, T...Cavenham Ho., Wrexham, Stoke Ferry  
 †Thorold, Sir J. H., Bt...Syston Park, Grantham  
 †Thorold, Richard...Weelsby Hall, Grimsby  
 †Thorp, Ven. Archdeacon...Kemerton, Tewkesbury  
 Thorpe, Henry...Buckingham  
 Thorpe, William...Nailstone, Hinckley  
 Thoys, Mortimer G...Sulhamstead House, Reading  
 †Throckmorton, Sir W., Bt...Buckland, Faringdon  
 †Thurlow, T. Lyon...Baynard Park, Guildford  
 †Thurnall, Henry...Royston, Herts.  
 Thursty, Lt.-Col. J. H...10, Green St., W.  
 Thursfield, T. H...Barrow, Broseley, Salop.  
 Thynne, Rev. A. C...Penstowe, Stratton, Cornwall  
 Thynne, F. Geo...11, Gt. George St., Westminster  
 †Tibbits, Capt. J. Borlace...Borlace Seagrave, Kettering  
 †Tiersonnier, A...Chateau du Columbier, près Nevers  
 Tiffen, Joseph...Sledmere Castle, York  
 †Tighe, Rt. Hon. W. F. Woodstock, Inistioige, Ireland  
 Tilden, John...Ifield Court, Gravesend  
 Tildesley, James...Willenhall, Wolverhampton  
 †Tillard, Philip...Stukeley Hall, Huntingdon  
 †Timbrill, Robert...Beckford, Tewkesbury  
 Timmis, Charles...Brick House, Stafford  
 Timson, Rev. Edward...Tatchbury, Southampton  
 Tinker, Henry...Holmfirth, York  
 Tinkler, Robert...Penrith  
 Tinley, Edward...Southwell, Nottingham  
 †Tinne, John A...Briarley, Aigburth, Liverpool  
 Tinsley, Henry, jun...Gedney Hill, Wisbeach  
 Tipper, Benjamin C...Bristol Road, Birmingham  
 Tisdall, E. C...Holland Park Farm, Kensington, W.  
 †Todd, John...Mireside, Wigton, Aspatia, Cumb.  
 Toder, Edward...South Muskham, Newark-on-Trent  
 †Tollemache, H. B...Jun. United Service Cl., S.W.  
 †Tollemache, J., M.P...Tilston Lodge, Tarporley  
 Tombs, John...Lower Farm, Langford, Lechdale  
 Tombs, J. King...Langford, Lechdale  
 Tomkinson, William...Newcastle, Staffs.  
 Tomline, Col. G., M.P...1, Carlton Ho. Ter., S.W.  
 †Tomlinson, Bruce...Asgarby, near Sleaford  
 Tomlinson, James H...The Parkey Farm, Wrexham  
 Tompkins, John...Town Farm, Ivinghoe, Triag  
 Tompson, E. C. S...Dromenagh, Iver, Uxbridge  
 Tompson, H. Kett...Witchingham Hall, Norwich  
 Tomson, James...Barnt Green, Redditch  
 Tongue, E...Manor House, Aldridge, Walsall

†Tooke, Rev. J. T. H....Scawby Vicarage, Brigg  
 Toomer, G. E....Hoaden House, Ash, Sandwich  
 Topham, T....The Twemlows, Whitchurch, Salop.  
 †Torr, John...Carlett Park, Eastham, Chester  
 Torr, Rev. T. J....Dummer House, Basingstoke  
 †Torr, William...Aylesby Manor, Great Grimby  
 Torrens, Robert, M.P....Carlton Club  
 Toulson, John Parker...Skipwith Hall, Selby  
 Tovey, Joseph...Cirencester  
 Toward, Andrew...Osborne, Isle of Wight  
 Towerson, John...Whitehaven  
 Towgood, Edward...St. Neot's  
 Towgood, Edward, jun....Sawton, Cambs.  
 Towgood, Hamer...Little Shelford, Cambs.  
 Townend, E....The Nook, Cullingworth, York  
 Townend, Thomas...Knockholt, Kent  
 †Townsend, Rev. C. G....Hatfield Peverel, Essex  
 Townshend, Charles...Chester  
 †Townshend, C. U....Hayley, Burlington Rd., Dublin  
 Townshend, Geo....Oulton Cottage, Lowestoft  
 Traherne, G. M....St. Hilary, Cowbridge  
 Travers, Peter F....Great Carlton, Louth, Linc.  
 Treadwell, John...Upper Winchendon, Aylesbury  
 Tredwell, J....Leigham Court, Streatham Hill, S.W.  
 Tredwell, William...Elsfield, Oxford  
 Trehonnais, R. F. de la...  
 Tremain, James...Polsue, Grampond, Cornwall  
 †Tremayne, John...Heligan, St. Austle  
 †Trench, Henry...Cangort Park, Roscrea, Ireland  
 Trench, W. S....Essex Castle, Carrickmacross, Ireland  
 Trethewy, A. H....Rhyd-y-crema, Llanrwst, N. Wales  
 Trethewy, Henry...Grampond  
 Trethewy, Henry, jun....Silsœe, Beds.  
 Trethewy, William...Tregoose, Probus  
 Trevelyan, Sir W. C., Bt....Wallington, Newc.-on-T.  
 Trimmer, Charles...Alton, Hants.  
 Trinder, Edward...Cirencester  
 Trinder, Thomas...Sandlin, Leigh Sinton, Malvern  
 Trood, Edward...Marford House, Exminster  
 Trotter, Thomas...Bywell, Stocksfield-on-Tyne  
 Trotter, Wm...South Acomb, Stocksfield-on-Tyne  
 Troutbeck, George...Barton-under-Needwood  
 Trower, Capt. E. S....Stansteadbury, Ware  
 †Troyte, C. A. W....Huntsham Court, Bampton  
 Trumper, Joseph...Lake End, Windsor  
 †Troy, Richard...Loddington Hall, Leicester  
 †Tryon, T....Bulwick, Wansford, Northamptonshire  
 †Tucher, Baron August...Nuremberg  
 Tuck, Rev. G. R....Blofield, Norwich  
 Tucker, Edwin...Frogmore Street, Abergavenny  
 †Tucker, Henry...Bourton Ho., Shrivensham, Berks  
 †Tuckett, P. D., jun....10a, Old Broad Street, E.C.  
 Tudge, William...Adforton, Leintwardine  
 †Tudor, Geo. S....Park House, Lapley, Penkridge  
 †Tull, Henry...Crookham, Newbury  
 †Tull, Richard...Crookham, Newbury  
 Tunncliffe, Edwin T....Bromley Hall, Eccleshall  
 †Turbervill, Maj. Picton...Ewenny Abbey, Bridgend  
 Turk, William...Charlton Kings, Cheltenham  
 Turnbull, George...Taghall House, Chat Hill  
 †Turnbull, John George...  
 †Turnbull, Rev. T. S....Blofield, Norfolk

Turner, E. R. T....St. Peter's Iron Works, Ipswich  
 Turner, Frank...North Bersted, Bognor  
 Turner, Frederic...Nizels, Tunbridge  
 Turner, Fred...St. Peter's Iron Works, Ipswich  
 Turner, F. J....Dean Castle, Kilmarnock, N.B.  
 †Turner, Lieut.-Col. F. Henry...Gouray, Jersey  
 Turner, George...Bramford Speke, Exeter  
 †Turner, George...Barnham, Thetford  
 Turner, George, jun....Alexton Hall, Uppingham  
 Turner, Jabez...Haddon Grange, Peterborough  
 Turner, J. Singer...Chyngton Farm, Seaford, Lewes  
 Turner, John...Englefield, Reading  
 Turner, John...The Grange, Ulceby  
 Turner, J. H....Little Horringer Hall, Bury St. Edm.  
 Turner, J. J....2, Montague Street, Edinburgh  
 Turner, Philip...The Leen, Pembridge, Herefordsh.  
 Turner, Robert...Bishopfield, Bawtry  
 Turner, Thomas...Merryvale, Ross  
 Turner, William...Newtown, Montgomeryshire  
 †Turnor, Christopher...Stoke, Grantham  
 †Turnor, E., M.P....Panton Hall, Wragby, Lincoln  
 †Turnor, E. Weston...Brereton, Rugeley  
 Turton, Rev. H., M...Hampstead Hospital, N.W.  
 Tuson, Rich. V...R. V. College, Camden Town, N.W.  
 Tuxford, Jos. Shephard...Skirbeck, Boston  
 Tuxford, Weston...Boston  
 Tweddle, John...Askerton Castle, Cumberland  
 Twentyman, A. C...Castlecroft, Wolverhampton  
 †Twinch, John...Thames Street, Windsor  
 †Tyacke, John...Merthen, Falmouth  
 †Tyler, Capt. G. G...The Callow Hill, Monmouth  
 †Tyler, Sir Jas., Kt...Pine House, Holloway, N.  
 Tyler, John...Leyton, Essex, N.E.  
 Tyler, J. Hawkins...Tytherington, Falfield, Glo'ster.  
 Tyndall, F. T...The Hill, Edgbaston, Birmingham  
 †Tyringham, Wm. B...Tyringham, Newport Pagnell  
 Tyrwhitt, Sir H., Bt...Ashwell Thorpe, Wymondham  
 Tyser, G. Dorman...Hollanden Park, Tonbridge

U.

†Umbers, Edward...Wappenbury, Leamington  
 †Umfreville, S. C....Ingress Abbey, Greenhithe  
 Underhill, W. S....Newport, Salop.  
 †Underwood, Joseph...5, Hyde Park Gardens, W.  
 Unite, John...29, Edgware Road, W.  
 Unthank, John...Nethers-ales, Penrith  
 †Upperton, Robert...35, Steyne, Brighton  
 Upton, H., jun....Aldwick, Bognor  
 †Usedom, The Baron von...Berlin

V.

Vachell, Edwin...Penarth, Cardiff  
 Vaizey, George De Horne...Haistead  
 †Vaizey, John Robert...Attwoods, Halstead  
 †Valle, Con de Del...Vergana, Gurpoisea, Spain  
 Vallentine, R...Burdett Lo. Fm., Leighton Buzzard

Valpy, Richard...5, Rutland Gate, S.W  
 Valpy, Robert Harris...Enborne Lodge, Newbury  
 †Van Alen, J. J....  
 †Vanderstegen, W. H....Cane End House, Henley  
 Vane, Sir Henry R., Bart....Hutton Hall, Penrith  
 Varnell, G. W....Beech Ho., Belton, Gt. Yarmouth  
 †Varty, Thomas...Stag Stones, Penrith  
 †Vaughan, Edmund M....Lapley, Penkridge  
 Vaughan, George L....Belmont Villa, Leicester  
 Vaughan, John W....Velin Newidd Ho., Brecon  
 †Vaughan, Nash V. E....Rhesta, Neath  
 Vaughan, W....Ruyton Eleven Towns, Salop.  
 †Vaux, Lord, of Harrowden...Highams, Bagshot  
 †Vavasour, Sir H. M....Manor House, Beaminster  
 †Veitch, Harry J....Exotic Nurseries, Chelsea, S.W.  
 Veitch, Jas....Exotic Nurseries, Chelsea, S.W.  
 †Vere, John...Carlton-upon-Trent, Newark, Notts.  
 †Verner, E. W., M.P....The Aske, Bray, Ireland  
 †Verney, Sir H., Bt., M.P....Clayden House, Winslow  
 Vernon, Benjamin...Aychley, Prees, Salop.  
 Vernon, Hon. F. H....Laundemer House, Oundle  
 Vernon, G. H....Grove Hall, East Retford, Notts.  
 Vernon, Hon. G. R....Auchan's Ho., Dundonald, N.B.  
 †Vernon, Harry F....Hanbury Hall, Droitwich  
 Vernon, William...Post Office, Tarporley  
 Verrall, Richard Relfe...Falmer, Lewes  
 Vesey, Lt.-Col. C. C....Lucan House, Lucan, Dublin  
 †Vevers, Charles...Ivington Park, Leominster  
 Vickerman, Charles R....Thoby Priory, Brentwood  
 Vickers, Thomas...Cheetham Hill, Manchester  
 †Vickers, V....Ellerton Grange, Newport, Salop.  
 Villar, James...Charlton Kings, Cheltenham  
 Villiers, Hon. F. W. C....Sulby Hall, Welford  
 †Vincent, James...Clifton Maybank, Yeovil  
 Vivian, George...11, Upper Grosvenor Street, W.  
 Vivian, Lord...Glynn, Bodmin  
 Vivian, Maj.-Gen. Sir R. J. H., Bt., K.C.B. .Caterham  
 Voile, John...Churchover, Rugby  
 †Voile, Thomas...Frolesworth, Lutterworth  
 Voss, W. J....West Bucknowle, Corfe Castle, Dorset

## W.

†Waddilove, G. M. D....Brunton House, Hexham  
 Waddingham, J....Guiting Grange, Winchcombe  
 †Waddington, John...Langrish House, Petersfield  
 †Wade, R....13, Seymour St., Portman Sq., W.  
 Wade, R. Craven...Clonbranie, Crossakeile, Meath  
 †Wadham, Edward...Mill Wood, Dalton-in-Furness  
 †Wagstaff, Thomas...Stifford Clay's Farm, Romford  
 †Wainman, B....Whitley Manor, Newport, Salop.  
 Waite, John N....Martham Hall, Gt. Yarmouth  
 †Wakefield, W. H....Sedgwick, Kendal  
 Wakefield, Wm. T....Fletchamstead Hall, Coventry  
 Walbey, Samuel...Barley, Royston  
 †Waldo, E. W. M...20, Calverley Park, Tun. Wells  
 Wale, H...Woodlands, Narborough, Leicestershire  
 Walker, Sir E. S., Knt...Berry Hill, Mansfield  
 †Walker, Frederick James...Claxton Grange, York

Walker, Frederick T....  
 Walker, George Henry...Newbold Grange, Rugby  
 Walker, G. J. Alexander...Norton, Worcester  
 Walker, James...Northleach  
 †Walker, James...Buriton Manor Farm, Petersfield  
 Walker, James R....Sandhutton, York  
 Walker, John...Westfield House, Holmer, Hereford  
 Walker, John...Goldington, Bedford  
 †Walker, John...Mount St. John, Thirsk  
 †Walker, John...  
 Walker, John Deverell...Nottingham  
 †Walker, John L...71, Oxford Terrace, Hyde Pk.  
 Walker, Joseph...Chorlton, Nantwich  
 Walker, Marmaduke...Addington, Croxson, S.E.  
 Walker, Matthew...Stockley Park, Burton-on-Trent  
 Walker, Ormerod Oliver...Bury, Lancashire  
 Walker, R. C....Owton Manor, Stockton-on-Tees  
 Walker, Robert Hay...Chillington, Wolverhampton  
 Walker, S...Chapel Ho., Tutbury, Burton-on-Trent  
 Walker, Thomas...Stowell Park, Northleach  
 Walker, Thomas...The Woodlands, Doncaster  
 Walker, Thomas S...Maunby Hall, Thirsk  
 Walker, William...Beeston, Nottingham  
 Walker, William...Victoria Iron Works, York  
 †Walker, Wm. H...38, Sackville Street, W.  
 Walker, William T...Clapham, Lancaster  
 Wall, Geo. Young, jun...39, North Bailey, Durham  
 Wall, Thomas...The Ford Farm, Droitwich  
 Wall, Thomas Senior...120, Maida Vale, W.  
 †Wall, W. H...Pembury, Tunbridge Wells, Kent  
 Wallace, Henry...Trench Hall, Gateshead  
 Waller, Hugh Sidney...Farmington, Northleach  
 Waller, Thomas...Sutton Hall, Woodbridge  
 Wallington, George...Wellesbourne, Warwickshire  
 Wallis, Arthur...Basingstoke  
 Wallis, Edward...Garrett Lane, Wandsworth, S.W.  
 Wallis, George...Old Shifford, Bampton, Faringdon  
 †Wallis, Owen...Bradley Hall, Bladon-on-Tyne  
 Wallis, Robert...Stocksfield, Northumberland  
 Wallis, Samuel...Barton Seagrave, Kettering  
 Wallis, Sergeant...Granchester, Cambridge  
 Wallworth, George...Bridgeford, Stone, Staffordshire  
 Wallworth, Joseph...Walton Hurst, Eccleshall, Staffs.  
 Wallworth, Joseph...White Hall, Wilmslow  
 Walmsley, G...Rudston Ho., Bridlington, Yorks.  
 †Walmesley, Richard...  
 †Walrond, J. W...Broadfield, Collumpton  
 †Walsingham, Lord...Merton Hall, Thetford  
 Walter, Capt. Edward...Tangley, Wokingham  
 Walter, John...Borden, Sittingbourne  
 Walter, William...Rainham, Sittingbourne  
 Walters, Stanley...Blythebury, Rugeley  
 †Walters, William...Haverfordwest  
 †Walton, Hewens S...Burmington, Shipston-on-Stour  
 Warburton, Rowland E.E...Arley Hall, Northwich  
 Ward, David...Iron Works, Melford, Sudbury  
 Ward, Felix J...The Lea, Cleobury Mortimer  
 Ward, John...East Mersea, Colchester  
 Ward, Robert...Harringworth, Uppingham  
 †Ward, Thos. J...Fern Park, Olveston, Bristol  
 Ward, William...41, St. Giles, Oxford  
 Ward, William...Penybout Hall, Oswestry

- †Ward, Wm. Squire...Wellow Hall, Ollerton, Notts.  
 Warden, T. Fawcett...Sedbergh, Kendal  
 †Wardle, Henry...Stanton House, Burton-on-Trent  
 Wardle, Joseph...Old Fens Hall, Whitchurch, Salop.  
 Ware, Rev. Charles...Astwood, Newport Pagnel  
 Ware, Jas. Thomas...Tilford House, Farnham  
 Waring, William...Chelsfield, Kent  
 Warington, R...Atlas Chemical Works, Millwall  
 Warner, Edward...Stowmarket  
 †Warner, George...Priory, Hornsey, N.  
 Warner, Henry, jun...Farringdon, Alton, Hants.  
 Warner, H. J. L., jun...Walsingham Abbey, Fakenham  
 Warner, James...Tixall Hall Farm, Stafford  
 Warner, Robert...8, The Crescent, Cripplegate, E.C.  
 †Warner, Thomas...47, Sussex Square, Brighton  
 Warner, Thomas...The Abbey, Leicester  
 Warner, W. H...99, Mount St., Grosvenor Sq., W.  
 Warre, H...Bexinden House, Langford Budville  
 †Warren, Rev. J. C. B...Horkesley Hall, Colchester  
 †Warren, R. A...Preston Place, Arundel  
 Warrington, William...Bretby, Burton-on-Trent  
 Warry, George...Shapwick, Glastonbury  
 Warter, H. de Grey...Longden Manor, Shrewsbury  
 †Wartnaby, John R...Clipston, Northamptonshire  
 †Wartnaby, Mrs...Market Harborough  
 Wasborough, Wm. Dowell...Stockham, Wantage  
 Wason, Rigby...Covvor, Grivan, Ayrshire  
 Waterer, Anthony...Knap Hill, Woking, Surrey  
 Waterhouse, Samuel, M.P...Halifax  
 †Waterpark, Lord...Doveridge Hall, Uttoxeter  
 Waters, Benjamin...Motcomb, Eastbourne  
 Waters, Richard...Charwelton House, Daventry  
 Watkin, John...Oil Mills, Leamington  
 †Watkins, J. G...Woodfield, Ombersley, Worcester  
 Watling, Robert S...Scrabby Hall, Great Yarmouth  
 Watney, Daniel...62, Old Broad Street, E.C.  
 Watson, C., M.D...1, South Crescent, Bedford Sq.  
 Watson, John...Shirburn Castle, Tetsworth  
 †Watson, John...Waresley, Kidderminster  
 Watson, John E...Newcastle-on-Tyne  
 Watson, Rev. Joshua R...Le Bocage, Guernsey  
 Watson, Robert...Scarrington, Whatton, Notts.  
 Watson, Robert...Standard Hill, Ninfield, Battle  
 Watson, R. H...Dorsely, Harburton, Devon.  
 Watt, J. W. Gibson...Doldolowe, Radnorshire  
 †Watterson, W. C...The Thorns, Bowdon, Altrincham  
 Way, L. A...Alderbourne, Gerard's Cross, Bucks.  
 †Wearing, J. W...Oxford  
 Weatherby, James...6, Burlington Street, W.  
 Weatherhogg, George William...  
 Weaver, Wm. R...108, Eastgate Street, Chester  
 Webb, Edward, jun...Worsley, Stourbridge  
 †Webb, Charles J...Brooklands, Ormskirk  
 Webb, Frederick Pace...Evesham  
 †Webb, Henry, jun...  
 Webb, Henry...14, Foregate Street, Worcester  
 Webb, H...Streety Hall, West Wickham, Linton  
 Webb, James...Fladbury, Pershore.  
 Webb, Lancaster...Combs Tannery, Stowmarket  
 Webb, Samuel...Babraham, Cambridge  
 Webb, Theodore V...Gransden, Caxton, Cambridge  
 Webb, Thomas...Hildersham, Cambridge  
 Webb, Wm...Chemical Manure Works, Worcester  
 Webb, Wm. Frederick...Newstead Abbey, Mansfield  
 †Webber, Charles Henry...Buckland, Barnstaple  
 Webber, W. Downes...Kellyville, Athy, Queens Co.  
 Webster, Charles...Waltham Abbey, Essex  
 †Webster, Charles...Cowley, Uxbridge  
 Webster, Crayston...Kendal  
 Webster, F...Marley Farm, Battle Abbey, Sussex  
 Webster, Frederick T...Bishton Hall, Shifnal  
 Webster, James...Peakirk, Market Deeping  
 Webster, Samuel...St. Mary's Place, Leamington  
 Weir, Edward...142, High Holborn, W.C.  
 Welby, E. M. Earle...Norton Leas, Sheffield  
 Welby, J. Earle...Allington Hall, Grantham  
 Welby, W. E., M.P...Newton Ho., Folkingham  
 Welby-Gregory, Sir G. E., Bart...Denton, Grantham  
 Welch, Alfred...Southall, Middlesex  
 Welch, Henry T...Leck Hall, Kirkby Lonsdale  
 †Welchman, Frederick R...Southam, Warwickshire  
 Weld, Edward J...Lulworth Castle, Wareham  
 †Wellingham, John...East Walton, Lynn  
 Wellington, Duke of...Apsley House, Piccadilly, W.  
 †Wells, Grenville G...Junior United Service Club  
 Wells, Henry...Occold, Eye  
 †Wells, John...Booth Ferry, Howden, Yorks.  
 †Wells, William, M.P...Holmewood, Peterboro'  
 †Welsh, John...Kirkton, Hawick, N. B.  
 Welstead, Fred...The Cottage, Stonely, Kimbolton  
 †Wenlock, Lord...Eserick Park, York  
 Wentworth, Godfrey H...Woolley Park, Wakefield  
 Were, Francis...Gratwicke Hall, Barrow Gurney  
 West, J...Melton Ross, Brigg  
 West, J. Roberts...Alscot Park, Stratford-on-Avon  
 †West, Richard Thornton...Streatham Hall, Exeter  
 †Western, Sir T., Bt...Felix Hall, Kelvedon  
 †Western, Thomas Sutton...Felix Hall, Kelvedon  
 Westhead, J. P. B., M.P...Lea Castle, Kidderminster  
 †Westhorpe, Rev. R. A...Berners Roding, Ongar, Essex  
 Westminster, Marquis of...Eaton Hall, Chester  
 †Westmoreland, Earl of...Apthorpe, Wandsford  
 †Weston James...Stoneleigh, Kenilworth  
 Weston, Philip...Coalbrookdale, Wellington, Salop.  
 Wetton, George N...Collingtree, Northampton  
 Wetton, Henry...Chertsey  
 †Weyland, John...  
 †Whalley, Chas. Lawson...Richmond Ho., Lancaster  
 Wharton, George Livingstone...Grovehill, Beverley  
 Wharton, Rev. J. C...Gilling, Richmond, Yorks.  
 †Wharton, J. Thomas...Skelton Castle, Guisborough  
 Wharton, Rev. W. F...Barningham Rect., Winstow  
 Wheatley, John...Neswick, Driffield  
 Whebie, James Joseph...Bulmerho Court, Reading  
 Wheeler, A. C...Kingsholm, Gloucester  
 †Wheeler, E. V...Kyrewood House, Tenbury  
 Wheeler, John...Long Compton, Shipston-on-Stour  
 Whibley, Jas. William...St. Julian's, Sevenoaks  
 Whitaker, B. J...Hesley Hall, Tickhill, Rotherham  
 Whitaker, John S...Bratton, Westbury  
 Whitaker, Joseph, jun...Ramsdale Ho., Nottingham  
 †Whitbread, S. C...49, St. George's Sq., S.W.  
 White, Arnold W...12, Gt. Marlborough St., W.  
 †White, Algernon Holt...Clement's Hall, Rochford

White, George...Hunton, Maidstone  
 †White, H. Wm....Lentran House, Inverness, N. B.  
 White, Rev. J. . . . Chevington, Bury St. Edmund's  
 White, John Baker. . . . Sreat End House, Canterbury  
 White, Samuel. . . . South Leventon, Retford  
 White, William. . . . Babworth, Retford  
 †Whitear, R. B. . . . Martyr-Worthy, Winchester  
 †Whitehead, Charles. . . . Barming House, Maidstone  
 †Whitehead, Jeffrey. . . . 39, Throgmorton Street, E.C.  
 Whitehead, J. . . . Barnjet, West Barming, Maidstone  
 Whitehead, Richard. . . . West Farleigh, Maidstone  
 Whitehead, William. . . . Weston, Market Deeping  
 Whitfield, Edward. . . . Oswestry, Salop.  
 Whitfield, G. . . . Chiswardine Park, Market Drayton  
 Whitford, Richard. . . . Avon Side, Evesham  
 †Whiting, Thomas C. . . . Barsham House, Beccles  
 Whitley, Henry E. . . . Farleigh, Basingstoke  
 Whitley, Nicholas. . . . Truro  
 Whitlock, F. . . . Lovingtons, Gt. Yeldham, Halstead  
 Whitlock, J. . . . Great Yeldham Hall, Halstead  
 Whitmell, J. Judkins. . . . Silsworth Lodge, Rugby  
 Whitmore, Rev. F. H. W. . . . Dudmaston, Bridgnorth  
 Whitmore, William. . . . Wickham Market  
 Whittaker, S. . . . Wellington, Salop.  
 Whittall, T. . . . Bailey Inon, Llandrindod Wells, Radnor  
 †Whitting, Wm. . . . Thorney, Peterborough  
 Whitworth, Geo. . . . Jamaica Level, Rotherhithe, S.E.  
 Whitworth, Henry. . . . 96, King Street, Manchester  
 Whitworth, H. B. . . . Northampton  
 †Whitworth, J. R. . . . Newport Pagnell  
 Whitworth, Sir Joseph. . . . Chorlton St., Manchester  
 †Wicks, J. Aldermaston House, 33, St. Luke's Road  
 Wicksteed, Rev. Charles. . . . Hafod, St. Asaph  
 Widdicombe, John. . . . Torrhill, Ivybridge  
 Widdicombe, Samuel. . . . Hay, Ugborough, Ivybridge  
 Wiendholt, Frederick. . . . Langharne, Carmarthenshire  
 Wiggins, Walter John. . . . Watlington, Oxon.  
 Wiggins, W. . . . Watlington, Tetsworth  
 Wigham, George. . . . Laverick Hall, Cramlington  
 †Wight, C. B. . . . Rudge Hall, Wolverhampton  
 †Wight, J. L. . . . Tedstone Ct., Bromyard, Hereford  
 Wightman, John. . . . Chard  
 Wigmore, John. . . . Weston-under-Penyard, Ross  
 †Wigram, John. . . . South Collingham, Newark  
 †Wigzell, Capt. A. D. . . . Sanderstead Court, Croydon  
 Wigston, R. . . . Horningsheath, Bury St. Edmund's  
 †Wilbraham, Hugh. . . . Westport, co. Mayo, Ireland  
 Wilbraham, Randle. . . . Rode Hall, Lawton, Cheshire  
 Wilde, H. J. . . . Hopstone, Claverley, Bridgnorth  
 Wilding, J. . . . Bank House, Tyldesley, Lancashire  
 Wiley, Samuel. . . . Bransby, York  
 Wilkes, Samuel. . . . Brewers Oak, Shifnal  
 Wilkins, Edmund. . . . Mortimer, Reading  
 Wilkins, Henry. . . . Westbury-on-Severn, Gloucester  
 Wilkins, Robert Osborne. . . . Broadfield, Buntingford  
 †Wilkinson, Charles. . . . Bank House, Kendal  
 Wilkinson, Edwin. . . . Isle of Cinder, Leeds  
 Wilkinson, H. John. . . . Walsham-le-Willows, Ixworth  
 Wilkinson, J. R. . . . Great Addington, Thrapstone  
 Wilkinson, Percival S. . . . Mount Oswald, Durham  
 Wilkinson, R. . . . Little Chilton, Ferry Hill, Durham  
 Wilkinson, S. W. . . . Apsley Cottage, Stockport  
 Wilkinson, Capt. Thos. H. . . . Walsham, Ixworth

Wilkinson, William. . . . Oxford  
 Willacy, Robert. . . . Penwortham Priory, Preston  
 Willett, Geo. W. . . . 2, Royal Crescent, Brighton  
 Willett, John S. . . . Petticombe, Torrington  
 Willett, Richard. . . . Shavington, Nantwich  
 Willetts, William. . . .  
 Williams, Chas. H. . . . Roath Court, Cardiff  
 †Williams, Ashley G. . . . Sparken, Worksop, Notts.  
 Williams, Charles. . . . Salisbury  
 Williams, David. . . . Dolseran, Dolgelly  
 Williams, E. A. . . . Gilli, Mold, Flintshire  
 Williams, Rev. E. T. . . . Caldicot Parsonage, Chepstow  
 Williams, F. E. . . . Derreana Ldge., Waterville, co. Kerry  
 †Williams, F. M., M.P. . . . Goonvrea, Perranarworthal  
 †Williams, G. . . . Buckland, Faringdon  
 Williams, Henry. . . . Alma, Truro  
 †Williams, H. E. 5, Willersley Villas, Birmingham  
 Williams, Sir Hugh, Bt. . . . Bodalwyddan, St. Asaph  
 Williams, Hugh. . . . Chesterton, Bridgnorth  
 †Williams, James. . . . Shippon, Abingdon  
 †Williams, John. . . . Gwrnhefin, Bala  
 Williams, John. . . . Bank, Chester  
 Williams, J. F. 10, Queen Sq., Bloomsbury, W.C.  
 Williams, Lewis. . . . Redwick House, Chepstow  
 Williams, Matthew. . . . Dryton, Wroxeter, Salop.  
 †Williams, R., jun. . . . Bridehead, Dorchester, Dorset  
 Williams, R. Ap Hugh. . . . Bodalwyddan, St. Asaph  
 Williams, Thomas. . . . Albrightlee, Shrewsbury  
 †Williams, W. . . . Plasgwyn, Pentraeth, Anglesea  
 †Williams, Wm. G. . . . Bodalwyddan, St. Asaph  
 Williams, William Propert. . . . Trehowell, Fishguard  
 †Williamson, H. . . . Greenway Bank, Burslem, Staffs.  
 Williamson, Sir H., Bt., M.P. . . . Whitburn, Sunderland  
 Williamson, Rev. R. H. . . . Hurworth, Darlington  
 †Williamson, W. E. . . . Catterick  
 †Willis, H. R. D'Anyers. . . . Bridgefield Ho., Liverpool  
 Willis, Thomas. . . . Manor House, Carperby, Bedale  
 Willis, William. . . . West Moulsey, S.W.  
 †Willoughby, W. . . .  
 Willows, J. Glover. . . . Rushton, Kettering  
 Wills, John. . . . South Petherway, Lauceston  
 Willson, J. Larkham. . . . Kimbolton  
 Willson, Thomas. . . . Biggin Grange, Oundle  
 †Willyams, E. Brydges, M.P. . . . Nanskeval, St. Colomb  
 Wilmot, R. C. . . . Woolley Park Farm, Wakefield  
 †Wilshe, Charles W. . . . The Frythe, Welwyn  
 †Wilson, Chris. . . . High Park, Oxenbolme, Kendal  
 †Wilson, Edward. . . . Hayes, Bromley  
 Wilson, Francis. . . . Ludford, Market Rasen  
 Wilson, George Crowle. . . . Dallam Tower, Milnthorpe  
 Wilson, George Henry. . . .  
 †Wilson, H. M. . . . Stowlangtoft, Bury St. Edmund's  
 Wilson, Jacob. . . . Woodhorn Manor House, Morpeth  
 †Wilson, Professor J. . . . University, Edinburgh  
 †Wilson, J. . . . Edington Mains, Aytton, Berwickshire  
 †Wilson, John. . . . Searcroft Hall, Leeds  
 Wilson, John. . . . St. Bees, Whitehaven  
 Wilson, John. . . . Aston Hall, Claverley, Bridgnorth  
 Wilson, Joseph. . . . Penrith, Cumberland  
 Wilson, John Simpson. . . . Higher Whitley, Northwich  
 †Wilson, J. W. . . . Austin House, Broadway, Evesham  
 Wilson, Matthew. . . . Eshton Hall, Gargrave, Leeds  
 †Wilson, Richard Bassett. . . . Cliffe House, Darlington



†Wilson, T....Shotley Hall, Newcastle-on-Tyne  
 †Wilson, Thomas Francis...Althorne, Maldon  
 Wilson, William...Baylham Hall, Ipswich  
 Wilson, William...Bulcote, Nottingham  
 Wilson, William...Oubas Hill, Ulverston  
 Wilson, Wm....Cholmondeley, Nantwich  
 †Wimbush, Barnes...New Barnet  
 Winchester, The Bishop of...Farnham Castle, Surrey  
 †Winchester, Marquis of...Amport House, Andover  
 Wing, Thomas Twining...17, Woburn Square, W.C  
 †Wing, William...Market Overton, Oakham  
 Wingfield, Charles...Onslow Hall, Shrewsbury  
 †Wingfield, J. H. Lee...Tickencote Hall, Stamford  
 Wingfield, R. Baker...Orsett Hall, Romford  
 Winn, Joseph...Uppingham  
 †Winn, Rowland, M.P....Appleby Hall, Brigg  
 Winnall, John...Eccleswell Court, Ross  
 Winter, Richard...The Levels, Thorne, Yorkshire  
 †Winterbottom, Jas. E....East Woodhay, Newbury  
 Winters, George...Stratton, Biggleswade  
 Winterton, Thomas...Alrewas Hay, Lichfield  
 Winthrop, Rev. Benjamin...Chippenham  
 Wise, George...Woodcote, Warwick  
 Wise, Josias P....Rostellan Castle, Cloyne, Ireland  
 Witherington, C....Rushall, Reading  
 Witherington, John...Germany House, Rugby  
 Withers, S. H....242, Oxford Street, W.  
 †Withington, T. Ellames...Calcheth Hl., Warrington  
 †Withington, James...Prestbury, Cheltenham  
 Witts, F. R. V...Up. Slaughter, Stow-on-the-Wold  
 Wodehouse, W. H....Woolmers Park, Hertford  
 Wollaston, Major F....Shenton Hall, Nuneaton  
 Wollen, Joseph...Wedmore, Somerset  
 Wolton, Horace...Newbourn Hall, Woodbridge  
 †Wolton, S....Butley Abbey, Wickham Market  
 †Wombwell, Sir G., Bart....Newburgh, Easingwold  
 †Wood, Bennett Wm....Humberstone, Gt. Grimsby  
 Wood, Charles A....Gt. Western Railway, Paddington  
 Wood, Edmund B....Moreton Hall, Chirk, Ruabon  
 Wood, Edw....Culmington Manor, Bromfield, Salop.  
 †Wood, George...Hatchlands, Guildford  
 Wood, George...Rochford, Essex  
 Wood, Henry...Woodhill, Send, Woking  
 Wood, Henry...Woolly House, Romsey  
 Wood, James...Ockley, Hurstpierpoint  
 Wood, James...Pinwall Hall, Atherstone  
 Wood, James...Haigh Hall, Wigan  
 Wood, J....Oaklands, Breeze Hill, Walton, Liverpool  
 †Wood, John...Welford, Rugby  
 Wood, John...Draycot-in-the-Clay, Uttoxeter  
 †Wood, John...Sheddon Grange, Alton  
 Wood, John...Harewood Hill, Darlington  
 Wood, J. P....Clumber Street, Nottingham  
 Wood, Richard...Potternewton, Leeds  
 †Wood, Rowland...Clapton, Thrapston  
 †Wood, Maj.-Gen. Thomas...Littleton, Chertsey  
 Wood, Walter A....77, Upper Thames Street, E.C.  
 Wood, William...Ifield Court, Crawley, Sussex  
 Wood, Willoughby...Holly Bank, Burton-on-Trent  
 †Wood, W. Bryan...Branbridge, Chippenham  
 Woodall, Thomas...Dinham, Chipstow  
 †Woodburne, T....Thurston, Newton-in-Cartmel  
 Woodcock, Henry C....Rearsby, Leicester

Woodcock, R., 20, Darlington Street, Wolverhampton  
 Woodd, B. T....Conyngnam Hall, Knaresborough  
 Woodfin, John...Aston, Wem, Salop.  
 †Woodham, W. Nash...Shepreth, Melbourne, Cambs.  
 Woodhouse, John...Skale Hall, Lancaster  
 Woodman, Richard, jun....Glynde, Lewes  
 Woodroffe, W. S....Normanton-on-Soar, Loughboro  
 Woods, Edmund Freeman...Stowmarket  
 Woods, Henry...Merton, Thetford  
 †Woods, James...Stowmarket  
 Woods, John A....Benton Hall, Newcastle-on-Tyne  
 Woodward, F. S....Blake Ho., Great Saling, Braintree  
 Woodward, Henry...Stanway Hall, Colchester  
 Woodward, Robert...Arley Castle, Bewdley  
 Woodward, Robert...Rise Hall, Akenham, Ipswich  
 Woodward, Thomas...High House, Severn Stoke  
 †Woodyear, Rev. J. F. W....Crookhill, Doncaster  
 Wooldridge, H....Meon Stoke, Bishop's Waltham  
 Woolf, Thos....Standon Hall, Eccleshall, Staffs.  
 Woollard, Joseph...Broxted Lodge, Hondon.  
 Woolley, Joseph...Allestree, Derby  
 Woolley, T.S., jun...South Collingham, Newark  
 Woolton, Charles...Elstree, Nutfield, Surrey  
 Woolnough, William...Kingston, S.W  
 Woosnam, Richard...Glandwr, Llanidloes  
 †Worley, Wm....Stanton Harcourt, Eynsham, Oxford  
 Worwick, Capt. R. W....Normanton Hl., Hinckley  
 Wortham, Biscoe Hill...Royston, Herts.  
 Worthington, Archibald...Whitechurch, Salop.  
 Worthington, G. Samuel...Cardiff  
 Wortley, Edw....Ridlington, Uppingham  
 †Wrench, Robert...39, King William Street, E.C.  
 Wright, Charles...Streatham, Ely, Cambs.  
 Wright, Edmund...Halston, Oswestry  
 Wright, Francis...Osmaston Manor, Derby  
 Wright, Frank...Hill Top Farm, Ashbourne  
 †Wright, G. T....Stoke Farm, Wokingham, Berks.  
 †Wright, Henry Banks...Sheldon Hall, Newark  
 Wright, Herbert...Ipswich  
 Wright, James...Cop House Farm, Saltney, Chester  
 Wright, John...The Terrace, Chesterfield  
 Wright, John...Buxton, Norwich  
 Wright, John...30, Broad St., Islington, Birmingham  
 Wright, Joseph...Grace Street, Leeds  
 Wright, Richard Merry...Coppenthal, Stafford  
 Wright, Robert John...Queen Street, Norwich  
 †Wright, Thomas...North Runcion, Lynn  
 Wright, Thomas...Wanlip, Leicester  
 Wright, Thos. Barr...Quarry Ho., Great Barr, Staffs.  
 †Wright, T. I....Seaton Burn House, Dudley, Northd.  
 Wright, Sir William...Siggleshorpe, Holderness  
 †Wright, William...Wollaton, Nottingham  
 Wright, William...Shoby Priory, Melton Mowbray  
 Wright, W...Fiskerton, Newark  
 Wright, W. Twaites...St. Nicholas, Cardiff  
 Wrightson, John...R. A. College, Cirencester  
 †Wrightson, R. Heber...Warmsworth Hl., Doncaster  
 †Wrightson, W. Battie...Cusworth Park, Doncaster  
 †Wrottesley, Lord...Wrottesley, Wolverhampton  
 †Wyatt, Robert...Acton Hill, Stafford  
 Wybergh, Francis...The Tower, Warcop, Penrith  
 †Wyles, Robert...Little Ponton, Grantham

LII *List of Members of the Royal Agricultural Society of England.*

Wyley, H. J. . . . Bridgnorth  
 †Wyley, James, jun. . . . Longdon, Rugeley  
 †Wyley, Wm. . . . Vineyard, Wellington, Salop.  
 †Wyley, Wm. John. . . . Admaston, Wellington, Salop.  
 Wyndham, Horace R. . . . Cockermouth  
 †Wyndham, J. E. . . . Exmouth, Devon  
 Wyndham, J. H. C. . . . Bishop's Waltham  
 Wynn, Richard. . . . Cricket, Ellesmere  
 Wynne, B. Wynne. . . . Garthwin, Abergele, Denbigh  
 Wynne, J. Lloyd, jun. . . . Coed Coch, Abergele  
 Wynne, Owen Slaney. . . . Peniarth, Towyn  
 Wynne, Wm. W. E. . . . Peniarth, Towyn, N. Wales  
 †Wyse, Robert. . . . Auburn Hill, Malton  
 Wythes, F. . . . Ravensden House, Bedford  
 †Wythes, George. . . .

†Yates, Henry. . . . North Parade, Grantham  
 Yates, James. . . . Aitchley, Shifnal, Salop.  
 Yates, William. . . . Grindle House, Shifnal  
 †Yeoman, Geo. Dundas. . . . Woodlands, Whitby  
 †Yeoman, R. C. . . . Wynyard, Stockton-on-Tees  
 Yeoman, Thos. L. . . . Woodlands, Whitby, Yorkshire  
 †Yeomans, John Haynes. . . . Stretton Court, Hereford  
 Yonge, Rev. Wm. J. . . . Rockbourne, Salisbury  
 Yorke, James N. . . . Newmarket  
 Yorke, Hon. Eliot Thos. . . . Wimpole, Cambridge  
 Yorke, Joseph. . . . Forthampton Court, Tewkesbury  
 †Yorke, T. E. . . . Halton Place, Hellifield, Leeds  
 Youmans, Richard. . . . Badby, Daventry  
 Young, A. A. . . . Orlingbury House, Wellingborough  
 †Young, George. . . . 17, Trinity Sq., Tower Hill, E.C.  
 Youngman, Philip. . . . Walsham-le-Willows, Ixworth

Y.

†Yarborough, Earl of. . . . Glanford Bridge  
 Yardley, Sir Wm., Kt. . . . Hadlow Park, Tunbridge  
 Yates, Frank G. . . . Ironbridge, Salop.

Z.

†Zoeppritz, G. . . . Ravensburg, Würtemberg, Germany

**Honorary Members.**

Dannfelt, C. Juhlin, Royal Agricultural College, Stockholm  
 De Lavergne, M. Leonce  
 Drouyn de L'huys, M., President of the Société des Agriculteurs de France, Paris  
 Hofman, Dr., 29, Park Square East  
 Lecouteux, M. Edouard, 43, Rue du Bac, Paris  
 Liebig, Dr. Justus, the University of Griessen, Hesse-Darmstadt  
 Napoleon III., His Imperial Majesty, Chiselhurst  
 Pasha of Egypt, His Highness the  
 Playfair, Dr. Lyon, C.B., University, Edinburgh  
 Simonds, James Beart, Oakington Park Farm, Willesden, Middlesex  
 Solly, Edward, Professor, Parkstone, Poole  
 Van de Weyer, M. Sylvian, Belgian Minister, 21, Arlington Street, S.W.  
 Voelcker, Professor, 11, Salisbury Square, E.C.  
 Way, John Thomas, 9, Russell Road, Kensington

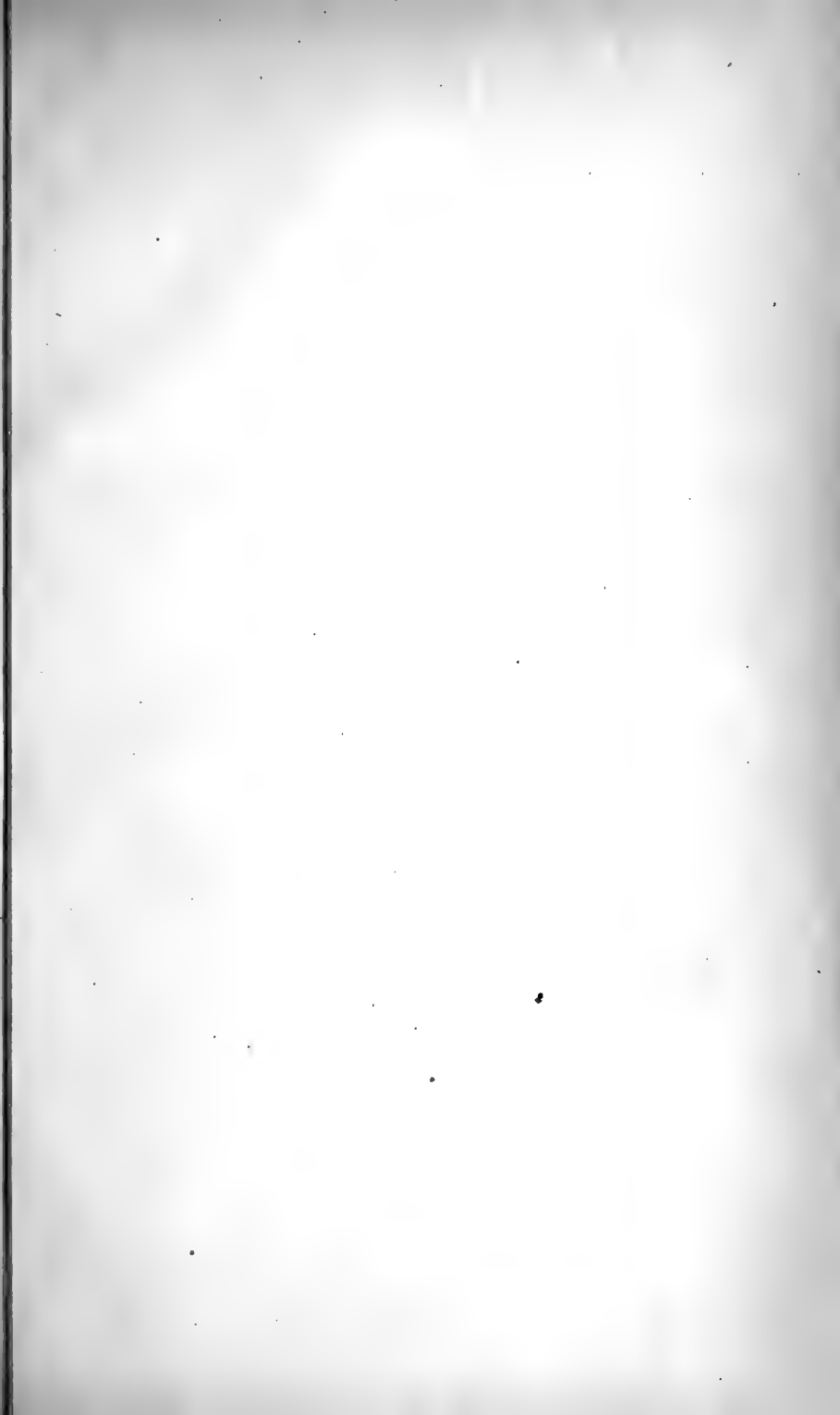

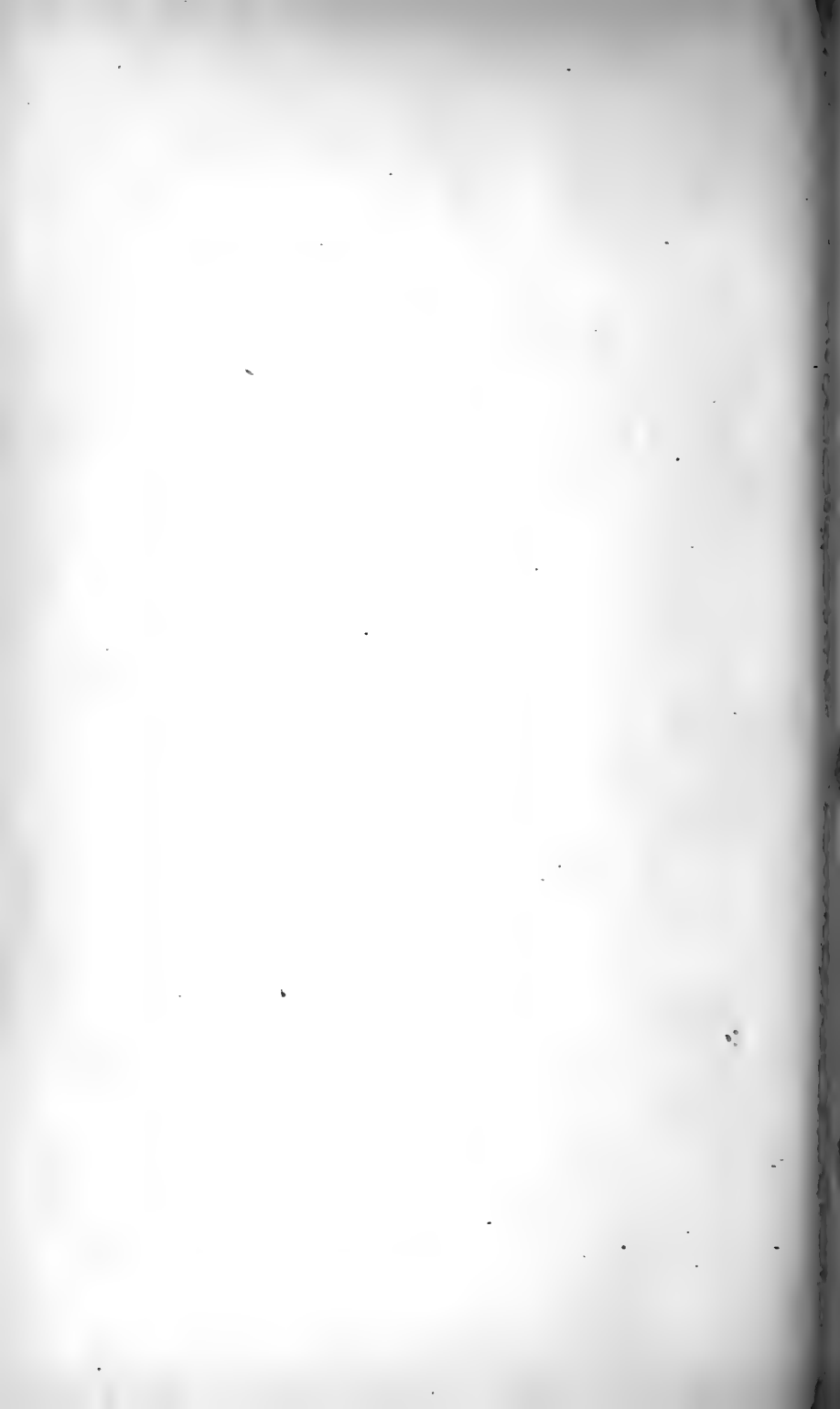

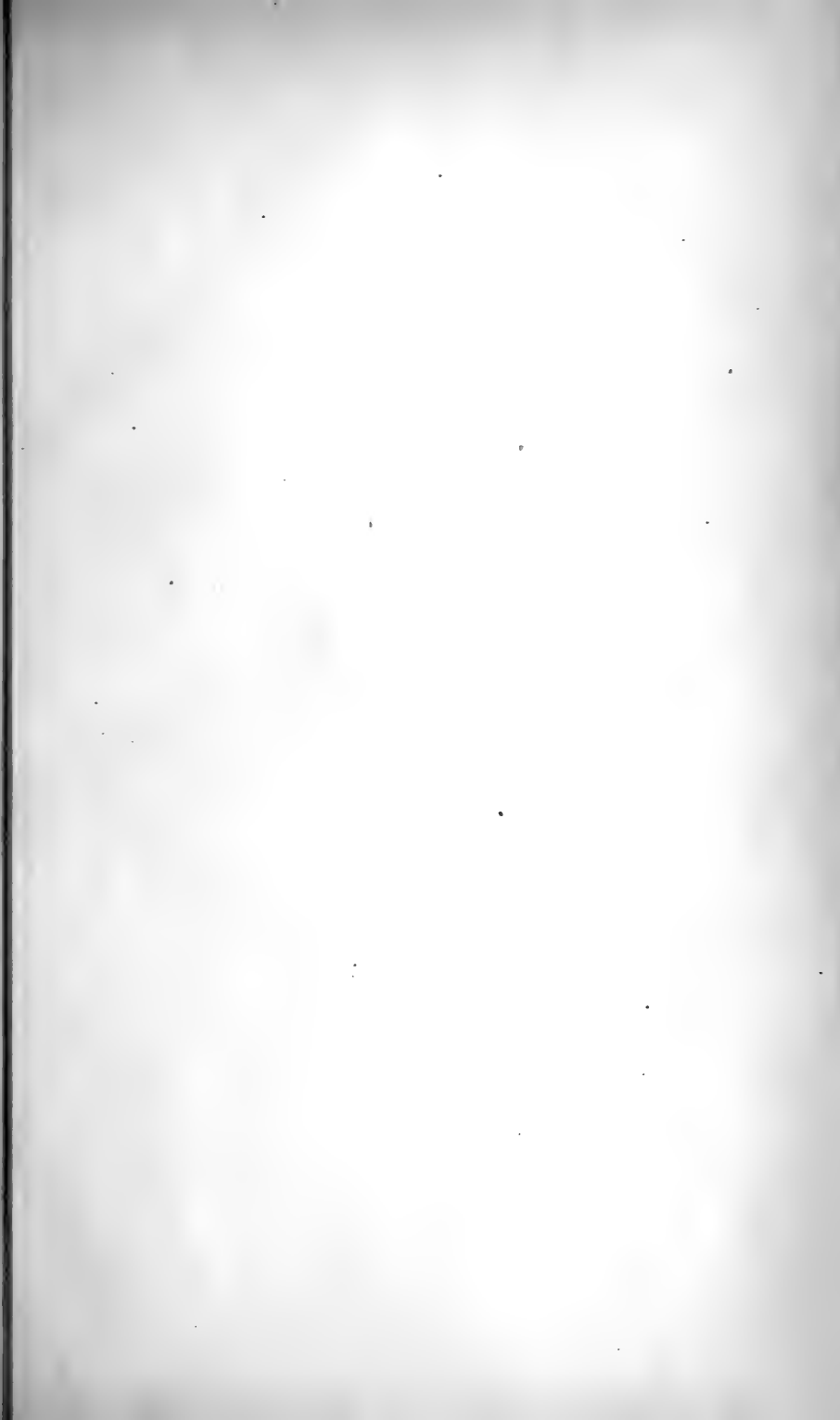

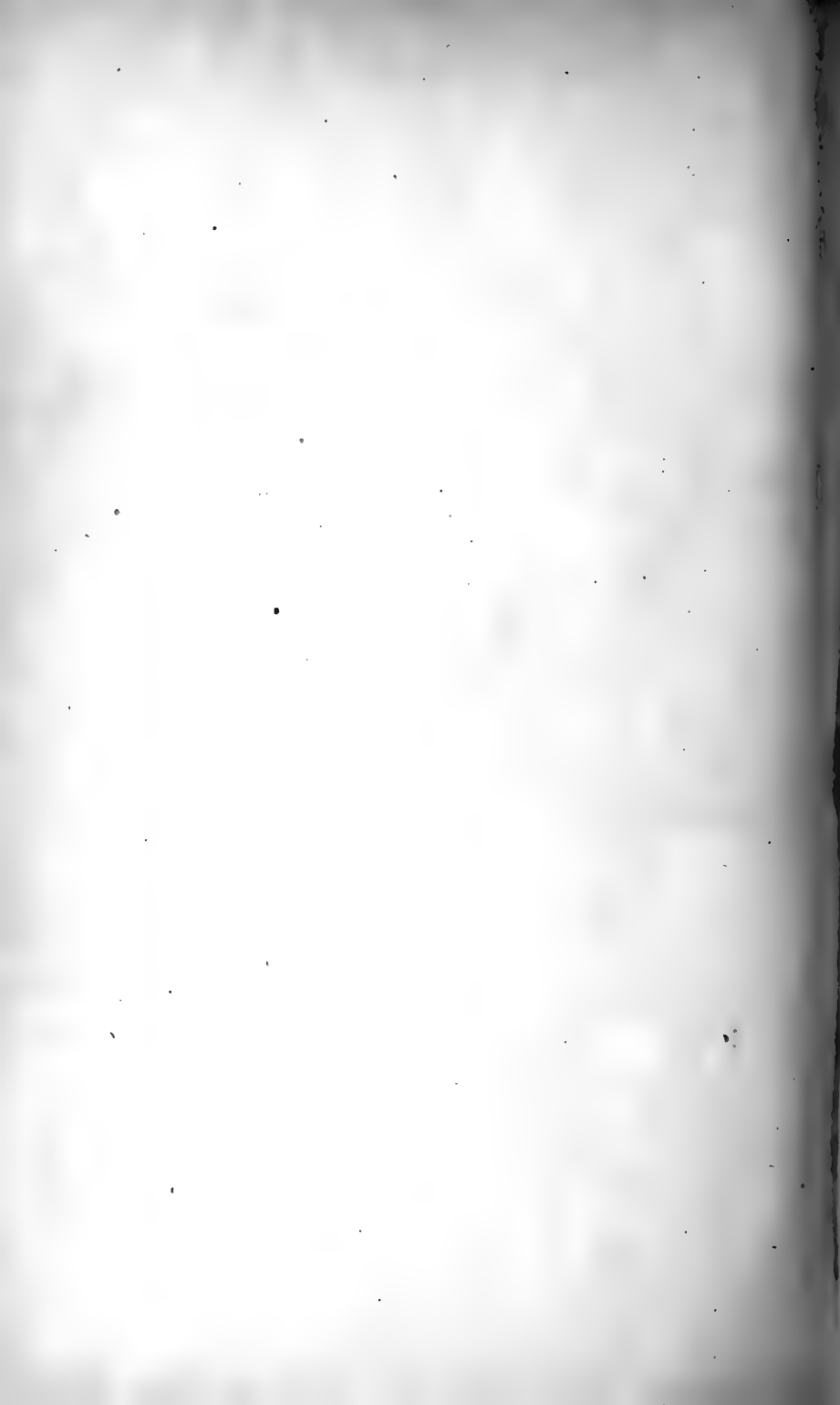



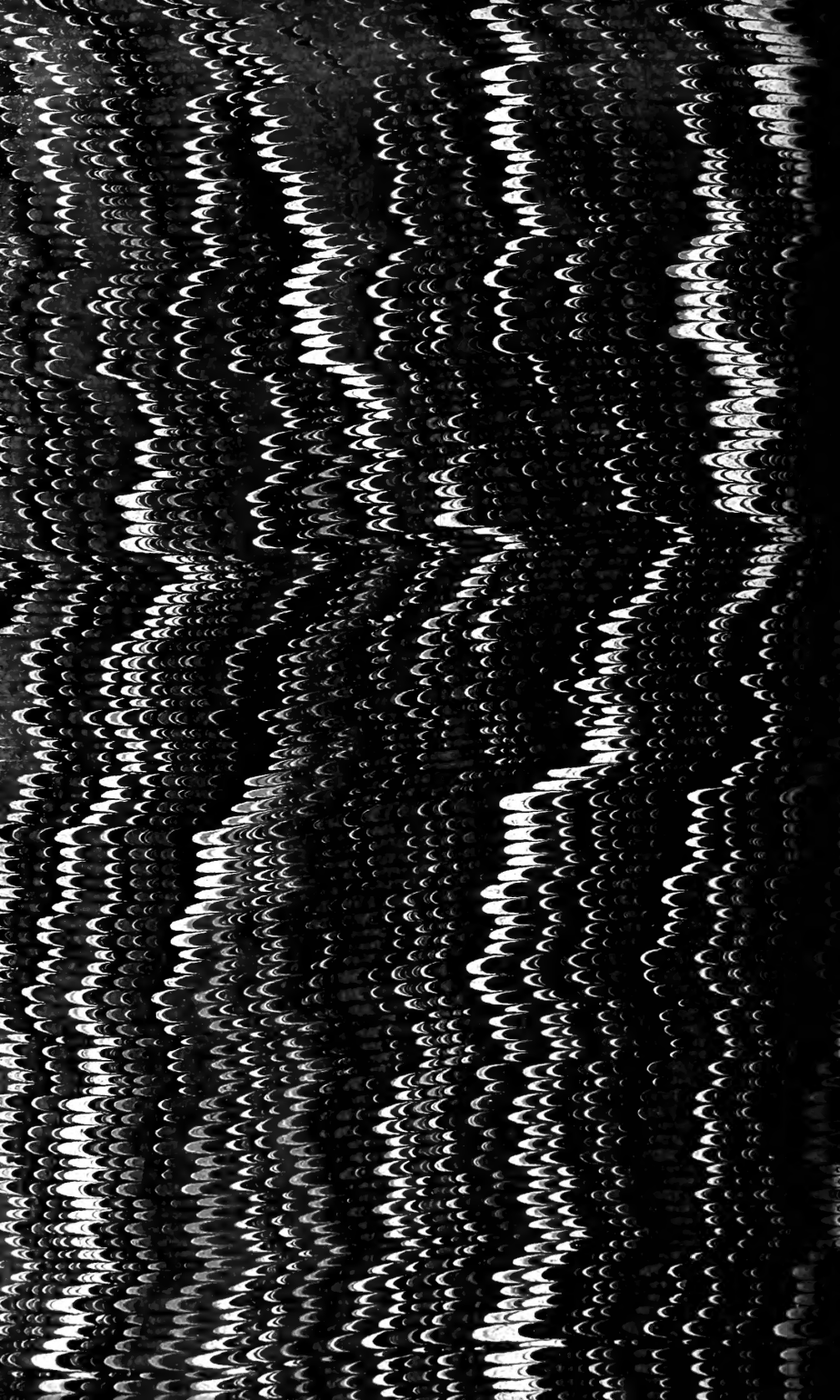



New York Botanical Garden Library



3 5185 00257 6419

